

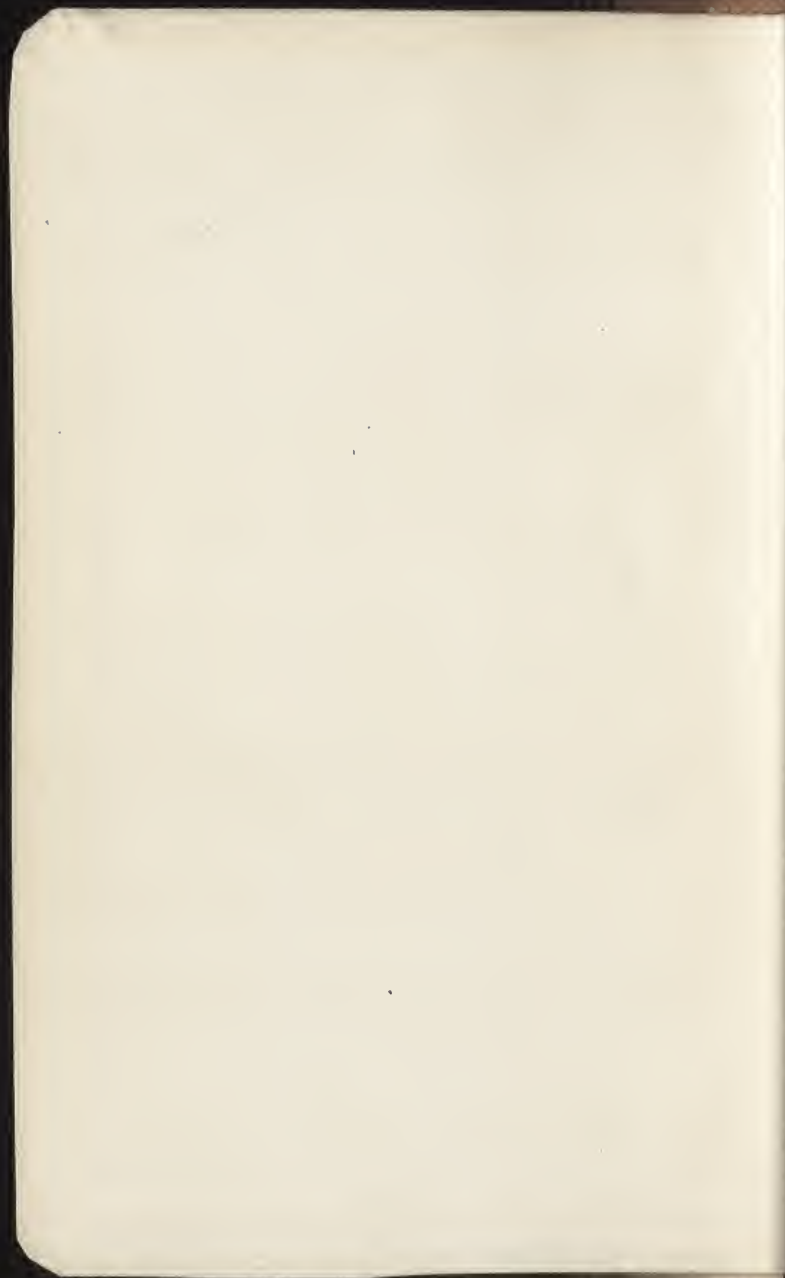

FRANKLIN INSTITUTE LIBRARY
PHILADELPHIA, PA.

REFERENCE





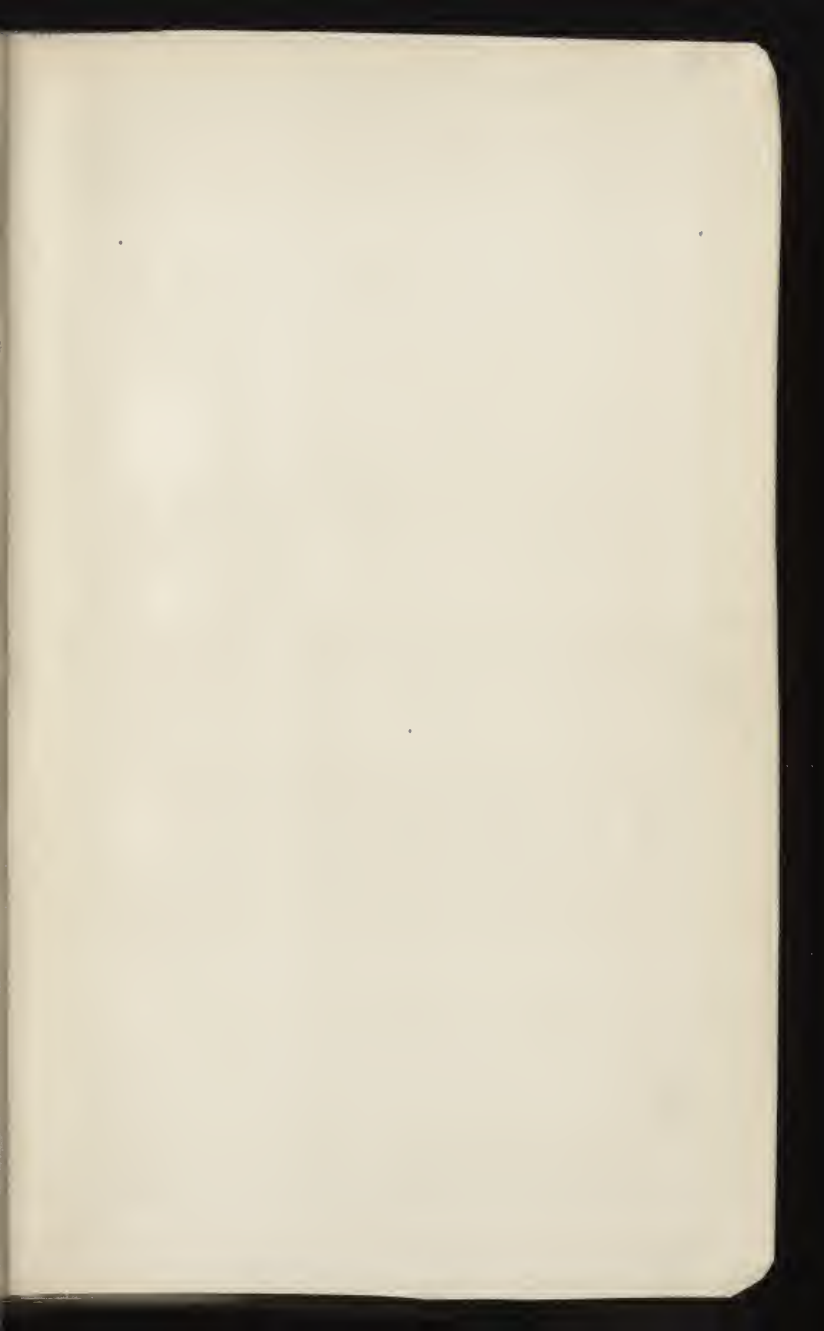



303
E
Engineers' Pocketbook

—OF—

Reinforced Concrete

By

E. LEE HEIDENREICH

M. Am. Soc. Test. Mat., M. W. S. E.

M. Am. Inst. Min. Eng.

W B STEPHENS
MEMORIAL LIBRARY
MAY 1909

CHICAGO AND NEW YORK
THE MYRON C. CLARK PUBLISHING CO.

LONDON

E. & F. N. SPON, LTD., 57 Haymarket

1909

CONS
TA
683
H45
1909

Copyright 1908

By

The Myron C. Clark Publishing Co.

REPORTS OF THE
VIRGIL JARVIS
MAYNARD

Composition and Presswork

By

THE WESTERN NEWSPAPER UNION

Chicago

PREFACE.

For the past fifteen years the author has been largely occupied with the study, exploitation and construction of reinforced concrete, and during this time has collected a very considerable amount of literature as well as personal experience in the subject, some of which in a more or less concise manner is laid before his engineering colleagues in this "Engineers' Pocketbook of Reinforced Concrete."

For a person occupied and making his living as an engineer it is at best a thankless task to write a pocketbook in his spare moments, but when the subject is so comparatively new and where such wonderful possibilities for additions and amendments are confronting one it is almost impossible to find a proper moment when the book may be considered temporarily finished.

From 1899 when the author wrote his first booklet, "Monier Constructions" (published 1900), reinforced concrete has made such gigantic strides forward, that it has entered every branch of civil engineering, and the American Society for Testing Materials in conjunction with the American Society of Civil Engineers through a Joint Committee for Concrete and Reinforced Concrete, of which the author is a member, is endeavoring to standardize specifications and to recommend factors and formulas "required in the design of structures in which this material is used." As yet this committee has not attained results further than "a knowledge of the work such a report demands."

Meanwhile the author has been writing, changing, substituting and improving the book for upwards of eight years and finally lets go of it for his own peace of mind, trusting to future opportunities for further changes and amendments. A pocketbook is needed, and the author presents this one for what assistance it may render to constructors in reinforced concrete.

The author wishes to express his appreciation to the many engineers and authors, from whose treatises quotations have been made.

"Le Beton Armé," by Paul Christophe; "Ciment Armé," by M. M. C. Berger and V. Guillerme; "Beton und Eisen," by Dr. F. von Emperger; "Concrete, Plain and Reinforced," by Taylor & Thompson; "Concrete and Reinforced Concrete Constructions," by Homer A. Reid; "Reinforced Concrete," by Buel & Hill; "Walls, Bins and Grain Elevators," by Prof. Milo S. Ketchum; "Reinforced Concrete Bridges and Viaducts," by John Podolsky, besides works by Prof. Arthur N. Talbot, Prof. Edwin Thacher, Walter W. Colpitts, C. E., and many others, have been referred to, whose names have been acknowledged in foot notes without intentionally missing any one.

A number of manufacturing establishments have courteously furnished much information as to their specialties and their address or place of business has been given for reference.

In the compilation of the different data, in calculations or checking of the many tables, in the research for information from current literature on the subject, both in Europe and in America, the author has been most ably and loyally assisted by Miss Alice Law, Chicago, for whose untiring efforts he hereby expresses his thankful appreciation.

E. LEE HEIDENREICH.

New York, December 1, 1908.

TABLE OF CONTENTS.

	Page
CHAPTER I.—MATERIALS AND MACHINES USED IN RE- INFORCED CONCRETE CONSTRUCTION.....	1
Definition of Reinforced Concrete—Cement: Portland Ce- ment—Barrels and Sacks—Storage—Standard Specifications— Necessity for Tests on the Work—Sampling Cement for Test- ing—Other Tests—Aggregates: Choice of Aggregates—Deter- mination of Voids in Aggregates—Table of Voids—Sand—Sele- ction of Sand—Sand for Mortar—Sand for Concrete—Table of Sand—Cleanness of Sand—Washing of Sand—Voids in Sand— Weight of Sand—Standard Sand—Screenings—Gravel—Choice of Crushed Stone—Size of Crushed Stone—Crusher Run—Rock Crushers—Table of Rock Crushers—Voids in Graded Mix- tures—Voids in Loose Broken Stone—Cinders—Mortar: Strength of Mortar—Volume of Mortar with Varying Proportions of Sand—Weight of Mortar—Mortar Tests—Retempered Mortar— Concrete: Proportioning Concrete—Usual Method of Propor- tioning Concrete—Fuller's Rule—Thacher's Table—Gillette's Formula—Proportioning Concrete for Maximum Strength—For Maximum Density—Concrete in Different Classes of Work— Mixing—Mixtures, Wet or Dry—Mixtures for Plain Concrete— For Reinforced Concrete—The Proper Consistency—Hand or Machine Mixing—Batch or Continuous Mixers—Classifica- tion of Batch Mixers—Table of Batch Mixers—Classification of Continuous Mixers—Table of Continuous Mixers—Hains Grav- ity Mixer—Steel: High or Low Carbon—Medium Steel—Per- centage of Reinforcement—Mechanical Bond—Reinforcing Steel—Loose Rods for Reinforcing—Square Bars and Round Rods—Twisted Bars—Corrugated Bars—Diamond Bars— Thacher Bars—Monolith Steel Bars—Cup Bars—Twisted Lug Bar—Wire Fabric—Tie-Locked Fabric—Lock-Woven Fabric— American Wire Fabric—Welded Wire Fabric—Expanded Metal —Kahn Rib Metal—Beam and Girder Units—Cummings Girder Frame—"Unit" Frame—Kahn Trussed Bar—Luten Truss— Monolith Frame—Pin-Connected Girder Frame—Hooped Col- umn Reinforcement—Cummings Hooped Column—American Hooped Column—Monolith Hooped Column—Smith Hooped Column—Structural Steel—I-Beams—Channels—Angles—Table of Area and Circumference of Circles—Table of Properties of Sections.	

	Page
CHAPTER II.—DESIGN AND CONSTRUCTION OF BUILDINGS	65
General Discussion: General Assumptions Made in Design—	
Percentage of Steel Reinforcement—Basis of Calculations—	
Dead Loads—Live Loads—Allowable Stresses—Bending Moments	
for Beams—Bending Moments for Slabs—Cross Reinforcement	
in Slabs—Location of Stirrups in Beams—Adhesion	
of Concrete to Steel—Modulus of Elasticity—Summary of Talbot's	
Tests on Tee Beams—Foundations: Types of Foundations—	
Bearing Power of Soils—Pile Foundations—The Raymond	
Pile—The Simplex Pile—The Corrugated Pile—The	
Chenoweth Pile—Other Forms of Piles—Pile Driving—Slab	
Foundations—Raft Foundations—Mat Foundations—Portable	
Foundations—Floors: Floor Loads—Factor of Safety—Classi-	
fication—Slab Floors—Beam Floors—Beam and Tile Floors—	
Arch Floors—Manufactured Floors—Floors Without Beams or	
Girders—Calculation of Slabs—Straight-Line Formula—Tables	
—Parabolic Line Formula—Tables—Maximum Bending Moment	
in Slabs—Beams and Girders: Loose Rod Systems—Frame	
Systems—Tables of Safe Loads and Steel Areas for Beams—	
Tables of Safe Load and Steel Area for Slabs—Columns:	
Classification—Rectangular or Polygonal Columns—Hooped	
Columns—Design of Hooped Columns—Tables—Considere's	
Formula—Euler's Formula—Structural Details: Roofs—Stairs	
—Structural Steel or Cast Iron Columns—Bracket Connections	
—Example of Building Designed According to the Foregoing	
Principles: Assumptions—Slabs—Beams—Girders—Location of	
Stirrups—Wall Girders—Roof Slab—Roof Beams and Roof	
Girders—Columns—Foundations—Raft 2-7—Quadrilateral Raft	
4-5-9-10—Square Footings 12, 13, 17 and 18—Conclusion—	
Sequence of Operations in Construction: Clearing the Site—	
Lumber and Reinforcing Materials—Placing the Reinforcement	
—Making Concrete—Delivering Concrete—Depositing Concrete	
—Concreting Columns—Concreting Walls—Joining Successive	
Days' Work—Protection of Concrete in Setting—Protection	
Against Freezing—Forms, Molds, Centering and Falsework:	
Kind of Lumber—Table of Working Stresses in Lumber—	
Points to Consider in the Design of Forms—Assumptions	
Made in the Design of Forms—Fastening of Forms—Joints in	
Forms—Spacing of Studs—Thickness of Lagging—Rotation in	
the Use of Forms—Alignment and Setting of Forms—Ad-	
hesion of Concrete to Forms—Time to Remove Forms—Column	
and Floor Forms—Forms in Combined Steel and Concrete Con-	
struction—Separately Molded Members—Eliminating the Use	
of Forms—Small Tools for Mixing, Conveying and Ramming	

	Page
—Finishing Concrete Surfaces: Types of Finish—Hair Cracks —Mortar Facing—Using Special Dry Mixture—Bringing Aggregates into Relief—Tooling—Plastering Concrete—Painting and Varnishing—Waterproofing.	
CHAPTER III.—THE DESIGN AND CONSTRUCTION OF BRIDGES	182
The Elastic Theory of Arches Simplified: Introduction—Reactions Caused by Concentrated Load—Successive Steps in the Design of an Arch—Line of Pressure Due to Dead Load—Line of Pressure for the Critical Condition of Loading—Critical Condition of Loading for a Given Section—Proof of the Correctness of Locating Points <i>A'</i> and <i>B'</i> —Approximate Analysis of Dead Load—Thickness of Arch Ring at Crown and Springing—Thickness of Arch Ring on Both Sides of Crown Down to the Skewback—Location of Neutral Axis—Thermal Stresses—Example of an Arch Designed According to the Elastic Theory: Assumptions—Constructing the Arch Ring—Dead Load Diagram—Live Load Diagram—Maximum Fiber Stresses—Table of Dead and Live Loads at Joints of Arch—Moments, Stresses, etc., at the Crown—Moments, Stresses, etc., at the Springing—Moments, Stresses, etc., at Joint 4—Construction: Classification of Arch Bridges—Construction of Arch Centering—Example of Centering for Two 50-ft. Arches—Centering for the Pollasky Bridge—Concreting the Arch—Removal of Arch-Centering—Grand River Bridge, Grand Rapids, Mich.—The Santa Monica Viaduct.	
CHAPTER IV.—ABUTMENTS AND RETAINING WALLS....	227
Theories for Pressure of the Filling: Rankine's Theory—Weyrauch's Theory—Coulomb's Theory—Cain's Theory—Trautwine's Theory—Rankine's Formulas—Cain's Formulas—General Discussion: Thrust—Back Filling—Drainage—Expansion Joints—Temperature Cracks—Masonry Retaining Wall: Calculation of Resultant Pressure—Stability Against Overturning—Stability Against Sliding—Stability Against Crushing—Reinforced Concrete Retaining Wall of Beam Type: The Vertical Beam—Foundation—Reinforced Concrete Retaining Wall With Counterforts: Calculation of Pressure <i>P</i> —Vertical Walls—Counterforts—Foundation—Conclusion—Retaining Wall Forms: Construction—Care of Forms—Setting the Forms—Removing the Forms—Expansion Joints—Wall Form Tie—Examples of Construction: Retaining Wall, Paris, France—Retaining Wall, Great Northern Ry., Wash.—Specifications for Reinforced Concrete Retaining Wall: General—Workmanship—Reinforcement—Loading and Risks—Measurement and Payment.	

	Page
CHAPTER V.—CULVERTS, CONDUITS, SEWERS, PIPES, AND DAMS.....	251

Arch Culverts: Box Culverts: Assumptions—Design of Covers for Box Culverts—Diagram for the Design of Covers for Box Culverts—Design of Sides of Box Culverts—Diagram for the Design of Sides of Box Culverts—Cost of Concrete Culverts—Examples of Arch Culverts: Standard Arch Culverts, C., B. & Q. R. R.—Arch Culvert, Kalamazoo, Mich.—Arch Culvert, Great Northern Ry.—Examples of Box Culverts: Standard Box Culverts, C., B. & Q. R. R.—Conduits, Sewers and Pipes: Erosive and Transporting Powers of Water—Resistance of Soil to Erosion by Water—Kutter's Formula—Table of Flow of Water in Circular Pipes—Grade of Sewers—Calculations—Calculation for Internal Pressure—Calculation for External Pressure—Weld's Formula—Example—Reinforcement for Sewers—Thickness and Weight of Reinforced Concrete Pipe—Stresses in Pipes and Rings According to Talbot's Researches—Concentrated Load—Distributed Vertical Load—Distributed Vertical and Horizontal Load—Summary of Tests Made on Concrete Pipes—Forms for Sewers—Dams: Classification—Comparative Features—Pressure on the Immersed Surface—Conclusion—Types of Construction—The Open Front Dam—The Half Apron Dam—The Curtain Dam.

CHAPTER VI.—TANKS, RESERVOIRS, BINS AND GRAIN ELEVATORS	286
--	-----

Tanks and Reservoirs: General Discussion—Shape or Form of Tanks and Reservoirs—Calculations—Table Giving Capacity of Tanks—Foundations—Tightness of Tanks—Reinforcement—Cost—Tank for Montgomery Ward & Co., Chicago Heights, Ill.—Tank for American Steel & Wire Co., Cleveland, O.—Forms for an Intake Tank—Battery Tanks—Bins and Grain Elevators: Action of Grain Flowing From a Bin—Bridging Action of Grain in a Bin—Table of Grain Pressure—Ratio of Grain to Liquid Pressure—Vertical Pressure—Ratio Between Lateral and Vertical Pressure—The Coefficient of Friction—Pressure of Coal in Bins—Tables of Pressure for Bituminous and Anthracite Coal—Weight, Angle of Repose and Angle of Friction of Various Materials—Capacity of Bins—Conclusions—Classification of Grain Elevators—Comparative Cost of Timber and Reinforced Concrete Elevators—Cement Storage Tanks, Illinois Steel Co., South Chicago, Ill.—Canadian Pacific Grain Elevator, Port Arthur, Ont.

	Page
CHAPTER VII.—CHIMNEYS, MISCELLANEOUS DATA, COST KEEPING, ESTIMATING, SPECIFICATIONS, ETC....	319
Chimneys: Calculation—The Core Theory—Wind Pressure and Velocity—Approximate Method of Calculation—Example —Summary of Points in Design of Chimneys—Construction— The Weber Steel Concrete Chimney—Construction of Molds— The Wiederholt Concrete Steel Chimney—Manufactured Ar- ticles: Inspection: Progress Reporting and Keeping of Costs: Blank Forms—Notes on Estimating: Plant Expense—Percent- age to Allow for Profits—Accident Insurance—Blank Form for Estimate of Building—General Specifications for Reinforced Concrete: In General—Cement—Sand—Gravel or Stone—Pro- portion—Mixing—Placing—Reinforcement—Expansion—Center- ing—Removal of Forms—Freezing Weather—Protecting Work —Fireproofing Structural Steel—Cement Finish—Stresses— Tests—Standard Specifications for Cement: Natural Cement— Portland Cement—Specific Gravity—Fineness—Time of Setting —Tensile Strength—Constancy of Volume—Sulphuric Acid and Magnesia—Uniform Tests of Cement: Sampling—Chemical Analysis—Specific Gravity—Fineness—Normal Consistency— Standard Sand—Mixing—Storage of Test Pieces—Tensile Strength—Constancy of Volume—Miscellaneous Information— Glossary of Terms Used in Plain and Reinforced Concrete.	

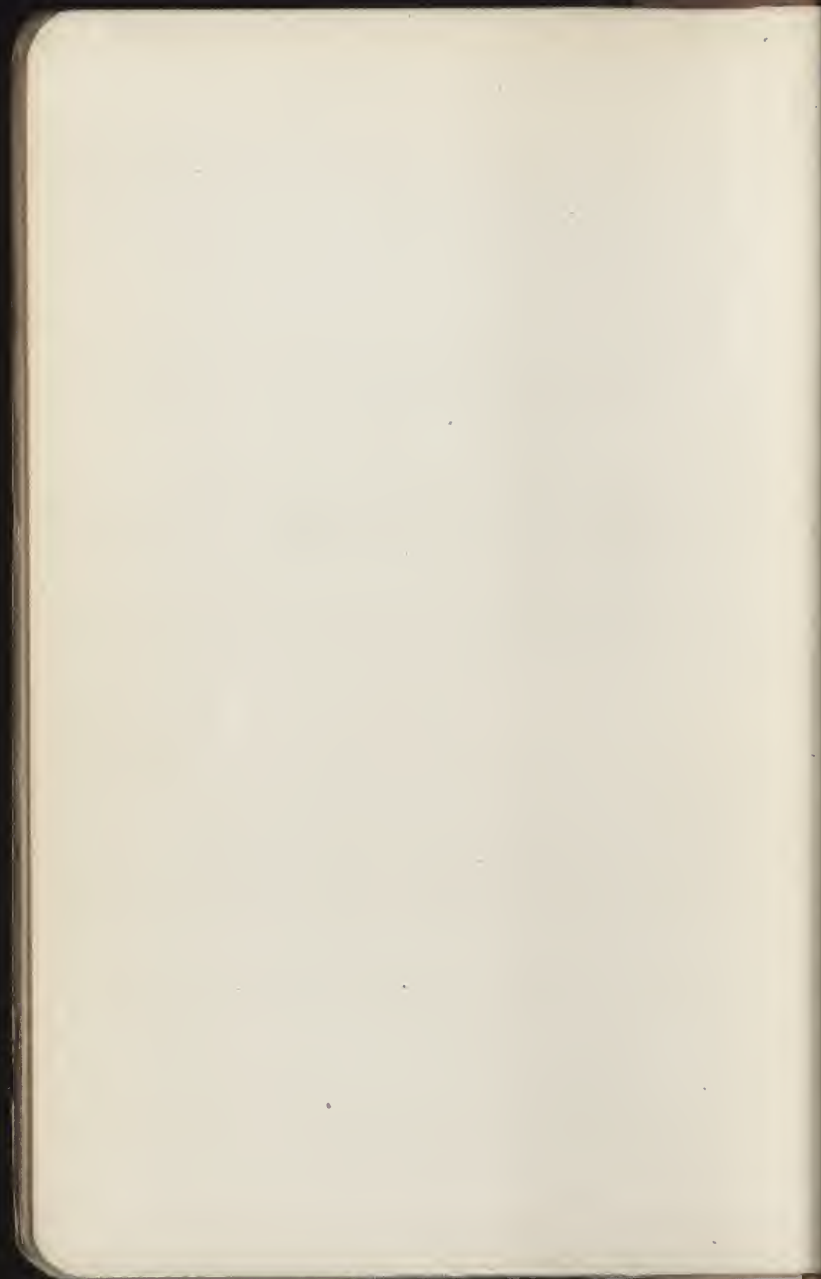

CHAPTER I.

MATERIALS AND MACHINES USED IN REINFORCED CONCRETE CONSTRUCTION.

Definition of Reinforced Concrete.—This material is a combination of concrete and steel, so united that the concrete takes the compression, while the steel takes the tension and assists in the resistance to shear. When reinforced concrete first appeared in America it was known as armored concrete; subsequent names applied to it have been ferro-concrete, ferro-cement, steel-concrete, and concrete-steel. At the present time, however, the term preferred by the majority of engineers and designers is reinforced concrete.

CEMENT.

Cement used in construction is either natural cement or Portland cement. Natural cement being manufactured in much less quantity, and being of inferior strength to Portland, is used so little in comparison with Portland cement that its use will be disregarded in this book.

Portland Cement.—The definition of Portland cement, recommended by the committee on standard specifications for cement of the American Society for Testing Materials, is “the finely pulverized product resulting from the calcination to incipient fusion of an intimate mixture of properly proportioned argillaceous and calcareous materials, and to which no addition greater than 3 per cent has been made subsequent to calcination.” This definition is supported by the American Association of Portland Cement Manufacturers, so that we may consider Portland cement to be nominally a definite, uniform product.

Barrels and Sacks.—Cement is sent from the mills in barrels or sacks. For long shipments or when there is risk of dampness, barrels are used, but the general mode of

transportation is in sacks. Portland cement barrels of different manufacturers vary in weight and capacity. If tightly packed, a barrel of Portland cement may contain only 3.5 cu. ft. and if very loosely measured the volume may be 4.2 cu. ft. or more. The generally accepted standard is that a barrel of Portland cement shall weigh 380 lbs. net, the barrel weighing 20 lbs. more, and that it shall contain 4 cu. ft. of cement measured loose. Four bags of cement are always assumed to be equivalent to a barrel; a sack of cement is then generally assumed to weigh 95 lbs., and to contain 1 cu. ft. of cement measured loose.

Cement sacks are made of either cloth or paper, cloth being preferred, as paper bags are easily torn in handling, causing waste of cement. Cloth bags may be returned, and will be re-purchased by the manufacturer; paper bags cannot be returned.

Storage.—Cement should be stored in a dry place. It is insufficient that it be stored out of the rain; storage in a damp basement will soon ruin cement by caking it, and it should not be stored upon the ground in wet weather. Cement should be rejected which has been wet, and caked into hard lumps. On large works, enough cement should be stored to last a month, in order that tests may be made, unless tests are made in the warehouse of the manufacturer. Cement several weeks old is better seasoned than that which is fresh from the mill. Well seasoned cement may be lumpy but the lumps are easily broken with the fingers, in which case the cement is entirely satisfactory.

Standard Specifications.—The recommendations of the committee on standard specifications for cement, of the American Society for Testing Materials, have been adopted by so many societies and companies that they may be regarded as practically the standard throughout the country. These requirements for Portland cement are set forth in the recommendations on the opposite page.

Necessity for Tests on the Work.—The manufacture of Portland cement has reached such uniformity that fairly

identical results may be attained by using any one of a number of well known brands, so that the choice of any particular brand is ruled largely by other considerations than its own intrinsic qualities. Though cement direct from the mill is uniform and reliable, it may not remain so, and tests on the work are therefore necessary to determine its genuineness, and whether it is reasonably sound, the soundness of a cement being a quality that can be readily affected by improper storage, etc. The fact that cement is satisfactory when tested is no indication that it will continue to be, hence cement which is not used for some time after test, should be tested again, if there is any possibility that damp weather or other factors have affected its soundness.

AMERICAN SOCIETY FOR TESTING MATERIALS' REQUIREMENTS FOR CEMENT.

SPECIFIC GRAVITY.

Dried at 100° C.....not less than 3.1

FINENESS.

Passing No. 100 sieve.....not less than 92% by weight
 Passing No. 200 sieve.....not less than 75% by weight

TIME OF SETTING.

Initial set.....in not less than 30 minutes
 Hard set.....In not less than 1 hour nor more than 10 hours

TENSILE STRENGTH, NEAT.

Age.	Strength.
24 hours in moist air.....	150-200 lbs. per sq. in.
7 days (1 day in moist air, 6 days in water)....	450-550 lbs. per sq. in.
28 days (1 day in moist air, 27 days in water)...	550-650 lbs. per sq. in.

TENSILE STRENGTH, ONE PART CEMENT, THREE PARTS SAND.

7 days (1 day in moist air, 6 days in water).....150-200 lbs.
 28 days (1 day in moist air, 27 days in water).....200-300 lbs.

CONSTANCY OF VOLUME.

Pats, neat, about 3 inches in diameter, one-half inch thick at the center, tapering to a thin edge, kept in moist air for 24 hours.

(a) A pat is then kept in air at normal temperature and observed at intervals for at least 28 days.

(b) Another pat is kept in water maintained as near 70° F. as practicable, and observed at intervals for at least 28 days.

(c) A third pat is exposed in any convenient way in an atmosphere of steam, above boiling water, in a loosely closed vessel for five hours.

These pats shall remain firm and hard and show no signs of distortion, checking, cracking or disintegrating.

SULPHURIC ACID AND MAGNESIA.

Anhydrous Sulphuric Acid (SO₃).....not over 1.75 per cent
 Magnesia (MgO).....not over 4 per cent

Sampling Cement for Testing.—The best sampler to use is one similar to a sugar-sampler, which takes a small cylinder of the material from the surface to the center of the bag. Small samples should be taken from a great number of bags and mixed. This gives a better average indication of the cement. On large works it is customary to sample every tenth bag. The cement so taken for testing purposes should be kept away from the air and dampness till made into paste, as otherwise it may not be in the same condition as the cement in the bags.

Other Tests.—Setting and hardening qualities should be noted by estimating the time required before a pressure of the thumb-nail is resisted by a cement pat. This point is where initial set ends and final set begins. Such tests should agree with the standard tests above. The color and weight of dry Portland cement are no indication of quality. Mr. W. Purves Taylor, in "Practical Cement Testing," states that cement balls made for tests should be soft, pliable, and damp on the surface, and should not feel warm at the end of 20 minutes. Cement failing in this is quick-setting. Such cement often becomes slow-setting on being stored a month or two. Good cement should have a uniform color when drying. Yellowish spots indicate poor cement. The color of cement hardening in air is a better indication than when hardening under water. The quantity of cement paste obtained by using different percentages of water is the same, per given weight of cement, provided the compacting is the same. Neat cement tests afford more information as regards the properties of the cement itself, than as regards how it will behave in the work; to get practical information regarding this, mortar and concrete tests are necessary as the testing of the aggregates to be used is of more practical value.

AGGREGATES.

The aggregates used with cement in the formation of concrete are generally sand or stone screenings and gravel or crushed stone.

Choice of Aggregates.—In general it may be said that concrete aggregates should be chosen which will undergo no future alterations, either disintegration due to chemical changes, or breaking of particles under the rammer, due to the presence of cracks or bruises received at the crusher. Other things being equal, rounded aggregates give greater density and a lower percentage of voids, since the compactness increases as the particles become more rounded. In all cases a well graded aggregate gives the best results; this means, not a mixture of two sizes of aggregate only, but a uniform gradation from the finest material up to the coarsest to be used. This will be further discussed under Concrete. An excess of medium sized particles of the aggregate decreases the density and also the strength of mortar or concrete. The shape of the particles of aggregate has little effect on mortar, except as to density, but concrete is affected by the shape of the particles, especially of coarse aggregate.

Determination of Voids in Aggregates.—While not suitable for laboratory practice, the following method of measuring voids in the field has been found adequate:

Fill a vessel of known capacity with the material, then pour in all the water it will contain; measure the volume of the water and divide by the volume of the vessel. The quotient expresses the percentage of voids. Some experimenters start with the material wet; others begin with it dry. The dry method allows a little larger factor of safety.

Table of Voids.—Table I gives the specific gravity, weight solid, and weight loose, of aggregates varying from a specific gravity of 1.0 to 3.5. To use the table, suppose an aggregate, for instance, limestone of specific gravity 2.6, contains 52 per cent of voids,—its weight per cubic yard is seen to be 2,101 lbs. Or suppose an aggregate weighing 162 lbs.

per cubic foot solid is found to weigh 2,625 lbs. per cubic yard when crushed, the voids are seen to be 40 per cent.

TABLE I.—PERCENTAGES OF VOIDS.

Specific Gravity	Solid Weight		Loose weight in lbs. per cubic yard when voids are:—					
	In lbs. per cubic foot	In lbs. per cubic yard	30%	32%	34%	36%	38%	40%
1.0	62.35	1684	1179	1145	1111	1077	1044	1010
2.0	124.7	3367	2357	2289	2222	2155	2088	2020
2.1	130.9	3536	2475	2404	2333	2263	2192	2121
2.2	137.2	3704	2593	2519	2445	2370	2296	2222
2.25	140.3	3788	2652	2576	2500	2424	2349	2273
2.3	143.4	3872	2711	2633	2556	2478	2401	2323
2.35	146.5	3956	2769	2690	2611	2532	2453	2374
2.4	149.7	4041	2828	2748	2667	2586	2505	2424
2.45	152.8	4125	2887	2805	2722	2640	2557	2475
2.5	155.9	4209	2946	2862	2778	2694	2610	2525
2.55	159.0	4293	3005	2919	2833	2748	2662	2576
2.6	162.1	4377	3064	2977	2889	2801	2714	2626
2.65	165.2	4462	3123	3034	2945	2855	2766	2677
2.7	168.4	4546	3182	3091	3000	2909	2818	2727
2.75	171.5	4630	3241	3148	3056	2963	2871	2778
2.8	174.6	4714	3300	3206	3111	3017	2933	2828
2.85	177.7	4798	3359	3263	3167	3071	2975	2879
2.9	180.9	4882	3418	3320	3222	3125	3027	2929
2.95	183.9	4967	3477	3377	3278	3179	3079	2980
3.0	187.1	5051	3536	3434	3333	3232	3131	3030
3.1	193.3	5219	3653	3549	3445	3340	3236	3131
3.2	199.5	5387	3771	3663	3556	3448	3340	3232
3.3	205.8	5556	3889	3778	3667	3556	3445	3333
3.4	212.0	5724	4007	3892	3778	3663	3549	3435
3.5	218.3	5893	4125	4007	3889	3771	3653	3536

Sand.—In order to distinguish between sand and gravel, an arbitrary line must be drawn between the two. In this work sand, except when referring to standard sand, will refer to all particles of gravel passing a No. 5 sieve (having openings 0.16 in. wide). This is sand about 1/6 in. in diameter and under, and is practically identical with the French limit suggested by Mr. Feret.

Selection of Sand.—The proper selection of sand as one of the aggregates for concrete is largely a matter of judg-

ment, as often, sands differing very materially in physical characteristics will make equally good concrete. Coarse

TABLE I. (Continued.)—PERCENTAGES OF VOIDS.

Loose weight in lbs. per cubic yard when voids are:—								Specific Gravity
42%	44%	46%	48%	50%	52%	54%	56%	
976	943	909	875	842	808	774	741	1.0
1953	1886	1818	1751	1684	1616	1549	1482	2.0
2051	1980	1909	1838	1768	1697	1626	1556	2.1
2148	2074	2000	1926	1852	1778	1704	1630	2.2
2197	2121	2046	1970	1894	1818	1742	1667	2.25
2246	2168	2091	2014	1936	1859	1781	1704	2.3
2295	2216	2136	2057	1978	1899	1820	1741	2.35
2344	2263	2182	2101	2021	1939	1859	1778	2.4
2392	2310	2227	2145	2063	1980	1897	1815	2.45
2441	2357	2273	2189	2105	2020	1936	1852	2.5
2490	2404	2318	2232	2147	2061	1975	1889	2.55
2539	2451	2364	2276	2189	2101	2014	1926	2.6
2588	2498	2409	2320	2231	2142	2052	1963	2.65
2636	2546	2455	2364	2273	2182	2091	2000	2.7
2685	2593	2500	2408	2315	2222	2030	2037	2.75
2734	2640	2546	2451	2357	2263	2168	2074	2.8
2783	2687	2591	2495	2399	2303	2207	2111	2.85
2832	2734	2636	2539	2441	2344	2246	2148	2.9
2881	2781	2682	2583	2483	2384	2285	2185	2.95
2929	2828	2727	2626	2525	2424	2323	2222	3.0
3027	2923	2818	2714	2609	2505	2401	2296	3.1
3125	3017	2909	2801	2694	2586	2478	2371	3.2
3222	3111	3000	2889	2778	2667	2556	2445	3.3
3320	3206	3091	2977	2862	2748	2633	2519	3.4
3418	3300	3182	3064	2946	2828	2710	2593	3.5

sand is generally better than fine sand; a coarse grain will have a smaller surface area than a number of fine grains of equivalent volume, so that coarse sand will be better coated than fine, with the same quantity of cement. For general work, a mixed sand is better than either, because of a better gradation of particles and a consequent lower percentage of voids.

Sand for Mortar.—Coarse sand is better for rich mortars, and fine sand is better for lean mortars. Fine sand makes a mortar of lower density; to remedy this a richer mixture

must be used. Mr. Feret's rule is that the coarse grains should be double the fine grains, including the cement. Fine sand may produce a mortar only one-third as strong as specially graded sand mixed with cement in the same proportions.

Sand for Concrete.—Sand for concrete requires more fine material than mortar sand, and tests indicate that the best percentages passing a No. 40 sieve may range from about 18 per cent for a 1-2-4 concrete up to 27 per cent for a 1-4-8 concrete. For water-tight concrete, even a larger percentage of fine grains appears to be beneficial.*

Table of Sand.—Table II from Gillette's "Handbook of Cost Data" gives the voids in sand from various localities.

Cleanness of Sand.—The phrase, "clean, sharp sand," for so many years a stereotyped form in specifications, is now obsolete. Sharpness of sand is of little value except when it indicates the presence of silica. Cleanness of sand is also disregarded by many engineers, who permit the presence of loam or clay; the quantity allowed is from 2 to 10 per cent, some authorities allowing even 15 per cent.† The author would prefer that all specifications should state that not over 5 per cent of loam or clay should be permitted in mortar or concrete for reinforced concrete work, as these impurities have a tendency to fill the small voids, preventing the cement from flowing in, and thereby reducing the adhesion between the cement and the aggregates, or the cement and the reinforcement. The permission to use sand with a small percentage of impurities is apt to be taken advantage of in a dangerous manner, for, except where silica is present, loam consists largely of vegetable mold, which should be guarded against.

Washing of Sand.—When sand containing loam or clay must be used, the impurities should be washed out. This

*Sand for Mortar and Concrete, Sanford E. Thompson, Bulletin No. 3, American Assoc. Portland Cement Mfrs., Philadelphia.

†For tests with sand containing loam and clay see Report, Chief of Engineers, U. S. A., 1896, p. 2826 et seq., and 1905, p. 3001; also C. J. Griesenauer, Engineering News, April, 1904; also Chas. E. Mills, Proc. Engineers' Club of Philadelphia, Pa., April, 1904.

TABLE II.—VOIDS IN SAND.

Locality.	Authority.	Voids.	Remarks.
Ohio River.....	W. H. Hall.....	31%	Washed
Sandusky, O.....	C. E. Sherman....	40%	Lake
Franklin Co., O.....	C. E. Sherman....	40%	Bank
Sandusky Bay, O.....	S. B. Newberry...	32.3%
St. Louis, Mo.....	H. H. Henby.....	34.3%	Miss. River
Sault Ste. Marie.....	H. von Schon.....	41.7%	River
Chicago, Ill.....	H. P. Boardman..	34 to 40%
Philadelphia, Pa.....	39%	Del. River
Mass. Coast.....	31 to 34%
Boston, Mass.....	Geo. A. Kimball..	33%	Clean
Cow Bay, L. I.....	Myron S. Falk....	40½%
Little Falls, N. J.....	W. B. Fuller.....	45.6%
Canton, Ill.....	G. W. Chandler...	30%	Clean

can be done by pouring the sand into the upper end of an inclined tank filled with water and having a small gate at the lower end, which permits the escape of the clean sand, the overflow of the water carrying away the dirt. Sand can also be washed in a concrete mixer.

VOIDS IN SAND.—The more rounded the grains of a mixed granular material, the lower the percentage of voids. Natural sand, therefore, with rounded grains, gives the lowest percentage of voids of any material used as an aggregate. Ground quartz (with angular grains) comes next, then crushed shells (with flat grains) and finally crushed quartzite (with laminated grains).* In all aggregates except sand the moistening of the material decreases the percentage of voids. This is because the addition of water destroys in part, the arching or frictional effect, permitting the finer material to enter the voids of the larger material. With sand, however, dampness holds the particles apart and increases the percentage of voids, the maximum occurring when the percentage of water varies from 5 to 8 per cent. The addition of more water, however, decreases the voids again, to practically the same as contained in dry sand. The following tests by Mr. Wm. B. Fuller† bear out the above statement, whether the sand be tested loose or compact:

* Mr. Feret.

† Reid, "Concrete and Reinforced Concrete Construction."

	Percentage of voids.	
	Loose.	Compact.
Dry	34	27
6 per cent water	44	31
Saturated	33	26.5

Weight of Sand.—From dealers' catalogs, bank sand is given as weighing 2,500 lbs. per cu. yd., and Torpedo sand, 3,000 lbs. per cu. yd.

Standard Sand.—As recommended by the American Society for Testing Materials, standard sand is the natural sand from Ottawa, Ill., screened to pass a sieve having 20 meshes per linear inch and retained on a sieve having 30 meshes per linear inch; the wires to have diameters of 0.0165 and 0.112 in., respectively, i. e., half the width of the opening in each case. Sand having passed the No. 20 sieve shall be considered standard when not more than 1 per cent passes a No. 30 sieve after one minute continuous sifting of a 500 gram sample.

Screenings.—Screenings are often used as a fine aggregate in place of sand. In using screenings, the aggregates should be carefully mixed dry, as otherwise the fine material will collect in lumps and impair the uniformity of the concrete. Under similar conditions, sand produces a denser concrete than screenings.*

Gravel.—Many engineers have a decided preference for gravel over crushed stone as an aggregate. Gravel is thought by many to be superior to crushed stone in that the well rounded pebbles, worn down as found in nature, are the survival of the best parts of the stone, the weaker portions having been worn away, also that round fragments offer less surface to be coated, thus insuring better union with the mortar and giving under similar conditions, a denser concrete than broken stone. The exponents of crushed stone, however, maintain that the rough surfaces and the angularity of broken fragments insure better bonding of the concrete. Practice in all lines of work has demonstrated that equally good concrete can be made with either.

*Fuller and Thompson, Trans. Am. Soc. C. E., 1907.

In using gravel, that containing mud or gravel cemented into lumps with mud, should be avoided.

Choice of Crushed Stone.—The best stone for crushing purposes is that which is hard and tough, breaking into angular fragments, with rather rough surfaces. Stone which breaks more easily in some directions than others, or exhibits cleavage, is hard to tamp compactly. Mica schist is of this class, and should be avoided for reinforced concrete, though it is allowable for massive construction. All things considered, trap rock makes the best aggregate, as it is tough, hard, bonds well, and furnishes a concrete of great strength. Crushed granite is also very good, unless the fragments are bruised in the crushing. Limestone is by far the most used, though when subjected to great heat, limestone will calcine and crumble. Some sandstones are used with excellent results, though, as a rule, sandstones are not considered strong enough. Stone which yields a great deal of fine material in crushing should be avoided as such stone is not strong.

Size of Crushed Stone.—The size to which an aggregate should be reduced by crushing depends upon the class of structure in which the stone is to be used. Since the largest stone makes the densest, and also the strongest concrete, the largest stone should be used that is consistent with proper placing, taking into account the dimensions of the mold, and the size and disposition of the reinforcing rods or wires.

In using large stone, care must be taken to prevent it from separating from the concrete, and to prevent it from moving the reinforcement out of place. Stone for reinforced concrete varies from $\frac{1}{2}$ in. to $1\frac{1}{2}$ ins., that passing a $\frac{3}{4}$ -in. ring or mesh being most common.

The following tests show that the size of the stone influences the density:*

*Fuller and Thompson, *Trans. Am. Soc. C. E.*, 1907.

Stone.	Density.	Ratio.
2¼ ins.	.847	1.00
1 in.	.814	.96
½ in.	.788	.93

Crusher Run.—When limestone is selected, the run of the crusher is often used for the entire aggregate. Unless care is exercised, however, the true run of the crusher will not be obtained, for, if the crushed stone is poured into a heap, a separation of the different sizes is sure to occur, in a greater or a less degree. To prevent this, the crushed stone should fall directly into the gage-box from the crusher. Even when the true run of the crusher is obtained, it is evident that the product may not be uniform. Slight variations in the hardness or texture of the stone may produce great variations in the size of the crushed material, the percentage of fine particles, etc. A more accurate method is to screen out the fine material and then mix in the required proportions.

Rock Crushers.—A great number of rock crushers are on the market. In general, it may be said that the same crusher will crush different aggregates to different percentages of voids, and that the capacity of the machine varies with many conditions. It is well known that the efficiency of a crusher is higher on a short time test than on a long time test, and while a crusher may be used up to its rated capacity for an hour or for a day, the average efficiency for a month will be found much less than this, usually about 50 per cent of the rated capacity. On one well-known work, a machine that puts out 175 cu. yds. per day of 10 hours, averaged 65 cu. yds. per day, when the monthly output was taken as a basis for calculation, this variation being due, not to the machine, but to the feeding and operating, which are difficult to maintain uniformly on long time tests.

Table of Rock Crushers.—The favorite crusher for use in concrete work is the gyratory crusher. Table III gives dimensions and other data regarding a well known make.

TABLE III.—GATES ROCK CRUSHERS, STYLE K.
Allis-Chalmers Co., Milwaukee.

Size	Dimensions of Each Receiving Opening, About	Weight of Breaker.	Capacity per hour, According to Character of Rock, in Tons of 2,000 lbs., to Pass Through a Ring of—								Smallest size Product	Driving Pulley.		Horse Power Required
			Inches	Lbs.	1½	1¾	2	2½	3	3½		4	Inches	
4	8 x 30	20900			15	20	25	30	40	1½		32 x 12
5	10 x 38	31200	30	40	50	60	70	1¾	36 x 14	375	22 to 30	
6	12 x 44	45500	50	70	80	90	2	40 x 16	350	28 to 45	
7½	14 x 52	64800	80	90	100	120	2½	44 x 18	350	50 to 75	

Voids in Graded Mixtures.—It is well known that different aggregates, screened so that the same proportions are retained on the same screens, will contain different percentages of voids. This is due to the fact that different kinds of rock crush into fragments of different degrees of regularity—some breaking cubically, others in sharp, angular fragments, etc. It is to be noted that, other things being equal, gravel contains a smaller percentage of voids, and weighs more per unit volume than crushed stone, which is equivalent to saying that the compactness increases as the particles become more rounded.

Voids in Loose Broken Stone.—For practical work, Table IV, from Gillette's "Handbook of Cost Data," gives percentages of voids for various kinds of stone from a number of localities.

Cinders.—Cinders are used for concrete in fireproofing work, such as floors. Such concrete is porous, and therefore a poor conductor of heat or sound, and is much lighter than stone concrete, as it weighs about 112 to 120 lbs. per cu. ft., while stone concrete weighs about 150 lbs. per cu. ft. Cinders for fireproofing work should be chosen carefully, as the presence of unburned coal will render such concrete the

TABLE IV.—VOIDS IN LOOSE BROKEN STONE.

Authority.	Voids. %	Remarks.
Sabin.....	49.0	Limestone, crusher run after screening out $\frac{1}{8}$ -in. and under.
"	44.0	Limestone (1 part screenings mixed with 6 parts broken stone).
Wm. M. Black.....	46.5	Screened and washed, 2 ins. and under.
J. J. R. Croes.....	47.5	Gneiss, after screening out $\frac{1}{4}$ -in. and under.
S. B. Newberry.....	47.0	Chiefly about egg size.
H. P. Boardman.....	39 to 42	Chicago limestone, crusher run.
"	48 to 52	" " screened into sizes.
Wm. H. Hall.....	48.0	Green River limestone, $2\frac{1}{2}$ ins. and smaller, dust screened out.
Wm. H. Hall.....	50.0	Hudson River trap, $2\frac{1}{2}$ ins. and smaller, dust screened out.
Wm. B. Fuller.....	47.6	New Jersey trap, crusher run, $\frac{1}{2}$ to 2.1 in.
Geo. A. Kimball.....	49.5	Roxbury conglomerate, $\frac{1}{2}$ to $2\frac{1}{2}$ ins.
Myron S. Falk.....	48.0	Limestone, $\frac{1}{2}$ to 3 ins.
W. H. Henby.....	43.0	" 2 -in. size.
"	46.0	" $1\frac{1}{2}$ -in. size.
Feret.....	53.4	Stone, 1.6 to 2.4 ins.
"	51.7	" 0.8 to 1.6 in.
"	52.1	" 0.4 to 0.8 in.
A. W. Dow.....	45.3	Bluestone, 89% being $1\frac{1}{2}$ to $2\frac{1}{2}$ ins.
"	45.3	90% being $\frac{1}{2}$ to $1\frac{1}{2}$ in.
Taylor and Thompson	54.5	Trap, hard, 1 to $2\frac{1}{2}$ ins.
"	54.5	" " $\frac{1}{2}$ to 1 in.
"	45.0	" " 0 to $2\frac{1}{2}$ ins.
"	51.2	" soft, $\frac{1}{4}$ to 2 ins.
G. W. Chandler.....	40.0	Canton, Ill.
Emile Low.....	39.0	Buffalo limestone, crusher run, dust in.
C. M. Saville.....	46.0	Crushed cobblestone, screened into sizes.

least fireproof, whereas it is supposed to be the most fireproof. Good boiler furnace cinders make the best cinder concrete. Cinders should be well wet before being used in concrete, and should not be heavily rammed, as the cinders will crush. Being porous and light in weight, cinders are not as strong as gravel or stone, and should not be used where strength is required, nor should cinder concrete be subjected to load before one month old.

When slag is to be used as an aggregate it should be allowed at least a year for aeration to get rid of the sulphur, which would disintegrate the concrete. Many failures have occurred from using slag not sufficiently aerated, as otherwise it is a satisfactory aggregate.*

*Thomas Potter, Builders' Journal, London, Dec. 5, 1906.

MORTAR.

Mortar is a mixture of cement, sand or screenings, and water. In European practice, mortar is often used in reinforced concrete construction. American practice limits the use of mortar to facing, finishing, etc., except in certain constructions, such as chimneys and water-tight receptacles.

Strength of Mortar.—The strength of mortar depends upon its density and the percentage of cement it contains. Evidently a change of density must be accomplished by the sand, since there is practically no variation in different cements. It has been found that sands with rounded grains contain the lowest percentage of voids, and therefore produce mortars of the least volume, which are the densest and strongest mortars. Apparent exceptions, where greater strength is obtained by using broken stone screenings, may be caused by the fine particles of the screenings uniting chemically with the cement. Coarse sand gives higher strength than fine sand. Mica, when laminated, may be injurious, having more effect upon the compressive than upon the tensile strength of mortar. Mica to 2 per cent is unimportant.

A formula for the strength of mortar* is as follows:

$$P = k \left(\frac{c}{1-s} \right)^2 \dots\dots\dots (1)$$

Where

P = the compressive strength of the mortar,

k = a constant,

c = volume of cement,

s = volume of sand.

The constant, k , varies between 201 and 1,500, according to conditions, such as the age of the test piece, time of immersion in water, etc.. While this variation affects the value of the formula, yet the relations between P , c , and s are clearly shown.

*Ferret, Etude Experimentale en Ciment Armé. p. 491.

The plastic mortars, which, per unit of volume, contain the greatest absolute volume of solid materials $c + s$, are those in which there are no medium grains and in which the coarse grains are found in a proportion double to that of the fine grains, including the cement. When this condition is attained, the density $c + s$ increases in proportion as the difference between the dimensions of the large and the fine grains increases.

Volume of Mortar, with Varying Proportions of Sand.—

Table V is compiled from experiments made by Mr. Edwin Thacher. All materials were measured loose, and gently shaken down. One barrel of cement contained 4.12 cu. ft. loose, thus requiring 6.56 barrels per cu. yd. One volume of Portland cement yielded 0.78 volumes of stiff cement paste on the addition of 0.35 volumes of water. The sand used was moist, ordinary coarse and fine mixed, containing 38 per cent of voids.

TABLE V.—VOLUME OF MORTAR.

Parts of sand mixed with								
1 part of cement.....	1.0	1.5	2.0	2.5	3.0	3.5	4.0	5.0
Volume of slush mortar..	1.40	1.78	2.17	2.55	2.98	3.39	3.82	4.65
Required for 1 cu. yd.—								
Cement, bbls.	4.70	3.70	3.04	2.58	2.21	1.94	1.72	1.41
Sand, cu. yds.	0.71	0.84	0.92	0.98	1.01	1.03	1.05	1.08
Volume of dry facing								
mortar (rammed)	1.22	1.57	1.93	2.28	2.64	2.99	3.35	4.08
Required for 1 cu. yd.—								
Cement, bbls.	5.40	4.18	3.41	2.88	2.49	2.20	1.96	1.61
Sand, cu. yds.	0.82	0.95	1.04	1.10	1.14	1.17	1.20	1.23

Weight of Mortar.—From experiments by Mr. Feret, it is found that 1-3 mortars with sand of fine, medium and coarse grains respectively, weigh approximately the same, 122 lbs. per cu. ft. If the three sands be mixed in the best proportions, the weight of the mortar reaches 141 lbs. per cu. ft., as shown in Table VI.

Mortar Tests.—Mortar tests on the work are receiving more attention than formerly, since it is found that tests involving the aggregates are of more value than tests of the cement alone. Cement is generally uniform when its soundness has been established, and steel for reinforcement is also uniform and reliable, but concrete aggregates vary consider-

ably in different parts of the country, so that statements made regarding a sand in one locality may not apply to that of another. Tests of cement were formerly the only tests made. Mortar and concrete tests are now assuming importance, and in all municipal work the tendency is to secure a maximum density of the aggregates by actual tests on the building premises, whereby a maximum economy may be reached simultaneously with maximum strength.

Retempered Mortar.—Generally speaking, mortar should not be used after it has attained a certain set, but there are instances where such mortar after being thoroughly reworked, preferably without adding any water, can be used to great advantage as a binder between old and new work—for instance, in repairing concrete sidewalks where the finish has scaled off, or for finishing rough surfaces.

TABLE VI.—WEIGHT OF MORTAR.

1-3 Mortar by Weight	Wt. in lbs. per cu. ft.	Density	Voids	Ratio compressive strength after one year	
				In fresh water	In air
Coarse Sand.....	122	.665	.335	.68	.60
Medium Sand.....	123	.640	.360	.45	.50
Fine Sand.....	123	.575	.425	.34	.34
Mixed in best pro- portions.....	141	.734	.266	1.00	1.00

CONCRETE.

Concrete is an artificial stone composed of cement with suitable aggregates, which may be sand and gravel, sand and crushed stone, screenings and crushed stone, or any other combination of these materials, before described.

Proportioning Concrete.—Many of the usual methods of proportioning concrete are unsatisfactory, owing to the fact that the laws governing the mixing and setting of concrete are not definitely understood. A number of formulas and rules have been devised to regulate the quantity of cement

and aggregates to use per cubic yard of concrete. The usual field practice in America is to take cement and aggregates by volume; in France, the cement is measured by weight, the aggregates by volume; in Germany both are measured by weight. In American testing laboratories, the practice is to measure cement and aggregates by weight.

Usual Methods of Proportioning Concrete.—Hitherto, the practice has been to mix concrete by taking 1 part cement with certain parts of sand and crushed stone or gravel. This practice is gradually changing, however, in view of the fact that the best concrete is that in which the aggregate is uniformly graded from coarse to fine. Another point in favor of abandoning the former method is that the 1-2-3 mixture of one contractor may be identical with the 1-3-5 mixture of another, owing to differences in the sizes of sand and stone. In view of this, it is preferable to abandon specifying mixtures as 1-2-3, 1-2-4, 1-3-5, but as 1-5, 1-6, 1-8, respectively, in which case the 5, the 6 or the 8 parts of aggregate are mixed up, reducing the voids to whatever figure is necessary for maximum density, and then the cement added. Both methods of proportioning will be considered, since both methods are in use at the present time. The best rules governing former practice are given below.

Fuller's Rule.—An approximate rule for ready calculation is the one originated by Mr. Wm. B. Fuller, and is as follows: Divide 11 by the sum of the parts (by volume) of all the ingredients; the quotient is the number of barrels of Portland cement required per cubic yard of concrete. Multiplying this by the number of parts of sand and of stone will give the number of barrels of each. To reduce barrels to cubic yards, multiply by 0.14 (since a barrel contains 3.8 cu. ft. and there are 27 cu. ft. in a cubic yard).

For example, suppose we wish to mix a concrete in the proportion 1-3-6. Then

$$6 + 3 + 1 = 10.$$

$11 \div 10 = 1.1$ barrels of cement required per cubic yard of concrete.

$3 \times 1.1 \times 0.14 = 0.462$ cu. yds. of sand required per cubic yard of concrete.

$6 \times 1.1 \times 0.14 = 0.924$ cu. yds. of crushed stone required per cubic yard of concrete.

Fuller's rule gives slightly more cement per cubic yard than is given in Table VII.

Thacher's Table.—Table VII is compiled from experiments conducted by Mr. Edwin Thacher. In these experiments, the volumes of all materials were measured loose, but gently shaken down. A barrel of cement was taken at 4.1 cu. ft.

Gillette's Formula.*—A very rational and satisfactory formula to govern the proportioning of cement is that devised by Mr. H. P. Gillette. The formula is as follows:

$$N = \frac{27}{p + ns(1.1 - 0.9v) + ng(1 - 0.9V)} \dots\dots(2)$$

in which

N = number of barrels of cement required to make 1 cu. yd. of concrete.

p = number of cu. ft. of cement paste per barrel as determined by actual test.

n = number of cu. ft. of cement per barrel.

s = parts of sand by volume to one part of cement.

g = parts of gravel or broken stone (by volume) to one part of cement, as specified.

v = percentage of voids in the dry sand, as determined by test.

V = percentage of voids in the gravel or stone as determined by test.

Figures obtained by using this formula compare very favorably with those obtained in actual test.

Proportioning Concrete for Maximum Strength.—It is well known that with any given sand and stone, with a fixed quantity of cement, the mixture that gives the least volume will furnish a cement of maximum strength. Such a mixture

*For derivation of this formula see Gillette and Hill, "Concrete Construction, Methods and Cost."

TABLE VII.—PROPORTIONS OF MATERIALS FOR CONCRETE.

Mixtures.		Required for one cubic yard rammed concrete.												
		Stone, 1 in. and und., dust screened out. (46% voids.)			Stone, 2½ in and und., dust screened out. (41% voids.)			Stone, 2½ in. with most small stones scr'n'd out (45% voids.)			Gravel, ¾ in. and under.			
Cement.	Sand.	Stone.	Cement, bbls.	Sand, cu. yds.	Stone, cu. yds.	Cement, bbls.	Sand, cu. yds.	Stone, cu. yds.	Cement, bbls.	Sand, cu. yds.	Stone, cu. yds.	Cement, bbls.	Sand, cu. yds.	Gravel, cu. yds.
1	1.0	2.0	2.57	0.39	0.78	2.63	0.40	0.80	2.72	0.41	0.83	2.20	0.35	0.74
1	1.0	2.5	2.29	0.35	0.70	2.34	0.36	0.89	2.41	0.37	0.92	2.10	0.32	0.80
1	1.0	3.0	2.06	0.31	0.94	2.10	0.32	0.96	2.16	0.33	0.98	1.89	0.29	0.86
1	1.0	3.5	1.84	0.28	0.98	1.88	0.29	1.00	1.88	0.29	1.05	1.71	0.26	0.91
1	1.5	2.5	2.05	0.47	0.78	2.09	0.48	0.80	2.16	0.49	0.82	1.83	0.42	0.73
1	1.5	3.0	1.85	0.42	0.84	1.90	0.43	0.87	1.96	0.45	0.89	1.71	0.39	0.78
1	1.5	3.5	1.72	0.39	0.91	1.74	0.40	0.93	1.79	0.41	0.96	1.57	0.36	0.83
1	1.5	4.0	1.57	0.36	0.96	1.61	0.37	0.98	1.64	0.38	1.00	1.46	0.33	0.88
1	1.5	4.5	1.43	0.33	0.98	1.46	0.33	1.00	0.51	0.35	1.06	1.34	0.31	0.91
1	2.0	3.0	1.70	0.52	0.77	1.73	0.53	0.79	1.78	0.54	0.81	1.54	0.47	0.73
1	2.0	3.5	1.57	0.48	0.83	1.61	0.49	0.85	1.66	0.50	0.88	1.44	0.44	0.77
1	2.0	4.0	1.46	0.44	0.89	1.48	0.45	0.90	1.53	0.47	0.93	1.34	0.41	0.81
1	2.0	4.5	1.36	0.42	0.93	1.38	0.42	0.95	1.43	0.43	0.98	1.26	0.38	0.86
1	2.0	5.0	1.27	0.39	0.97	1.29	0.39	0.98	1.33	0.39	1.03	1.17	0.36	0.89
1	2.5	3.5	1.45	0.55	0.77	1.48	0.56	0.79	1.51	0.58	0.81	1.32	0.50	0.70
1	2.5	4.0	1.35	0.52	0.82	1.38	0.53	0.84	1.42	0.54	0.87	1.24	0.47	0.75
1	2.5	4.5	1.27	0.48	0.87	1.29	0.49	0.88	1.33	0.51	0.91	1.16	0.44	0.80
1	2.5	5.0	1.19	0.46	0.91	1.21	0.46	0.92	1.26	0.48	0.96	1.10	0.42	0.83
1	2.5	5.5	1.13	0.43	0.94	1.15	0.44	0.96	1.18	0.44	0.99	1.03	0.39	0.86
1	2.5	6.0	1.07	0.41	0.97	1.07	0.41	0.98	1.10	0.41	1.03	0.98	0.37	0.89
1	3.0	4.0	1.26	0.58	0.77	1.28	0.58	0.78	1.32	0.60	0.80	1.15	0.52	0.72
1	3.0	4.5	1.18	0.54	0.81	1.20	0.55	0.82	1.24	0.57	0.85	1.09	0.50	0.75
1	3.0	5.0	1.11	0.51	0.85	1.14	0.52	0.87	1.17	0.54	0.89	1.03	0.47	0.78
1	3.0	5.5	1.06	0.48	0.89	1.07	0.49	0.90	1.11	0.51	0.93	0.97	0.44	0.81
1	3.0	6.0	1.01	0.46	0.92	1.02	0.47	0.93	1.06	0.48	0.97	0.92	0.42	0.84
1	3.0	6.5	0.96	0.44	0.95	0.98	0.44	0.96	1.00	0.45	1.01	0.88	0.40	0.87
1	3.0	7.0	0.91	0.42	0.97	0.92	0.42	0.98	0.94	0.42	1.05	0.84	0.38	0.89
1	3.5	5.0	1.05	0.56	0.80	1.07	0.57	0.82	1.11	0.59	0.85	0.96	0.50	0.76
1	3.5	5.5	1.00	0.53	0.84	1.02	0.54	0.85	1.06	0.56	0.89	0.92	0.48	0.78
1	3.5	6.0	0.95	0.50	0.87	0.97	0.51	0.89	1.00	0.53	0.92	0.88	0.46	0.80
1	3.5	6.5	0.92	0.49	0.91	0.93	0.49	0.92	0.96	0.51	0.95	0.83	0.44	0.82
1	3.5	7.0	0.87	0.47	0.93	0.89	0.47	0.95	0.91	0.49	0.98	0.80	0.43	0.85
1	3.5	7.5	0.84	0.45	0.96	0.86	0.45	0.98	0.86	0.47	1.01	0.76	0.41	0.87
1	3.5	8.0	0.80	0.42	0.97	0.82	0.43	1.01	0.81	0.45	1.04	0.73	0.39	0.89
1	4.0	6.0	0.90	0.55	0.82	0.92	0.56	0.84	0.95	0.58	0.87	0.83	0.51	0.77
1	4.0	6.5	0.87	0.53	0.85	0.88	0.53	0.87	0.91	0.55	0.90	0.80	0.49	0.79
1	4.0	7.0	0.83	0.51	0.89	0.84	0.51	0.90	0.87	0.53	0.93	0.77	0.47	0.81
1	4.0	7.5	0.80	0.49	0.91	0.81	0.50	0.93	0.84	0.51	0.96	0.73	0.44	0.83
1	4.0	8.0	0.77	0.47	0.93	0.78	0.48	0.95	0.81	0.49	0.98	0.71	0.43	0.86
1	4.0	8.5	0.74	0.45	0.95	0.76	0.46	0.98	0.78	0.47	1.01	0.68	0.42	0.88
1	4.0	9.0	0.71	0.43	0.97	0.73	0.44	1.01	0.75	0.45	1.04	0.65	0.40	0.89
1	5.0	9.0	0.66	0.50	0.90	0.67	0.52	0.93	0.70	0.53	0.96	0.61	0.46	0.83
1	5.0	10.0	0.62	0.47	0.95	0.63	0.48	0.96	0.65	0.50	1.00	0.57	0.43	0.87

is the densest obtainable under the given conditions, and is obtained when the volume of cement, sand and water just fills the voids in the stone. The density of concrete has been found to vary considerably by varying the proportions of the aggregates.

Proportioning Concrete for Maximum Density.—In this connection may be cited the field method devised by Mr. Wm. B. Fuller, which is to determine the maximum density by trial. His method is as follows:

“Procure a piece of steel pipe 8 to 12 ins. in diameter and about a foot long and close off one end, also obtain an accurate weighing scale. Weigh out any proportions selected at random, of cement, sand and stone, and of such quantity as will fill the pipe about three-quarters full, and mix thoroughly with water on an impervious platform, such as a sheet of iron; then, standing the pipe on end, put all the concrete in the pipe, tamping it thoroughly, and when all is in measure and record the depth of the concrete in the pipe. Now throw this concrete away, clean the pipe and tools and make up another batch with the total weight of cement, sand and stone the same as before, but with the proportions of the sand to the stone slightly different. Mix and place as before and measure and record the depth in the pipe, and if the depth in the pipe is less and the concrete still looks nice and works well, this is a better mixture than the first. Continue trying in this way until the proportion has been found which will give the least depth in the pipe. This simply shows that the same amount of material is being compacted into a smaller space and that consequently the concrete is more dense. Of course, exactly similar material must be used as is to be used on the work, and after having in this way decided on the proportions to be used on the work it is desirable to make such trials several times while the work is in progress, to be sure there is no great change in materials, or, if there is any change, to determine the corresponding change in the proportions.

“The above described method of obtaining proportions does not take very much time, is not difficult, and a little trouble taken in this way will often be productive of very important results over the guess method of deciding proportions so universally prevalent.

“A person interested in this method of proportioning will find on trial that other sands and stones available in the vicinity will give other depths in the pipe, and it is probable that by looking around and obtaining the best available materials the strength of the concrete obtainable will be very materially increased.

“As a guide to obtaining the best concrete, the proportion of cement remaining the same, the following are the results of extensive tests:

“The stone should all be of one size or should be evenly graded from fine to coarse, as an excessive amount of the fine or middle sizes is very harmful to strength.

“All of the fine material smaller in diameter than one-tenth of the diameter of the largest stone should be screened out from the stone.

“The diameter of the largest grains of sand should not exceed one-tenth of the diameter of the largest stone.

"The coarser the stone used the coarser the sand must be, and the stronger, more dense and watertight the properly proportioned work becomes.

"When small stones only are used the sand must be fine and a larger proportion of cement must be used to obtain equal strength."

A set of test beams has shown the following decrease in strength, due to decrease in density:

Proportions.	Modulus of Rupture. Lbs. Sq. In.
1 : 2 : 6	319
1 : 3 : 5	285
1 : 4 : 4	209
1 : 5 : 3	151
1 : 6 : 2	102
1 : 8 : 0	41

By inspecting the above figures it is seen that although the amount of cement in each of the above beams was the same (namely, 1-9 of the total material), some of the beams were over 700 per cent stronger than others.*

Concrete in Different Classes of Work.—By properly proportioning concrete, a great saving in materials can be effected. Lean mixtures can be used in heavy construction where the concrete is stressed only in compression. Also the richness of the mixture can be varied in different parts of the same structure, according to the nature of the stress, reinforcement, etc.

Mixing.—The mixing of concrete is as important as the choice of the aggregates. In general, it may be said that mixing for a long time retards setting and increases strength and bond capacity. Thorough mixing is essential in order to produce a coherent and uniform concrete. The leaner and dryer the mixture the more mixing is required. Some constructors mix the materials dry till a uniform color and appearance are secured before the water is added. Others put in the material and the water at once. Either way will produce good results except for hand mixing, where the mixing of the materials in the dry state is the general practice.

Mixtures, Wet or Dry.—Dry mixtures are of advantage because the forms need not be as tight, but more mixing of the dry materials and more tamping are required. Wet mix-

*William B. Fuller.

tures require less tamping, but the forms must be tighter. With dry mixtures the forms may be removed sooner, and they are used where quick set and quick strength are required. Mixtures too wet will separate and the cement will go to the bottom. Dry mixtures require more wetting subsequent to placing than wet mixtures, because, to set properly requires a certain amount of water; if this is not all supplied in the mixing, it should be supplied afterward. Whether wet or dry mixtures are used depends chiefly upon the temperature and the class of work.

Mixtures for Plain Concrete.—For plain concrete, the author agrees with Mr. H. W. Parkhurst,* who summarizes as follows:

A medium concrete or one that has not enough surplus water to produce quaking, while having enough to permit easy and thorough ramming, is the most desirable. To specify that the concrete should not quake in the barrow nor in handling, but when heavily rammed, would seem about right for regulating the amount of water. It is probably safer to have an excess of water than a deficiency. Above all, it is of the utmost importance that concrete shall be thoroughly consolidated by ramming. If too wet, ramming will tend to separate the ingredients, and if too dry, no reasonable amount of ramming will fill the voids with mortar.

Mixtures for Reinforced Concrete.—Wet mixtures for reinforced work are preferred in America, though no hard and fast rule can be laid down to gage the proportion of water.

The quantity of water varies, first, with the temperature. During hot weather, a so-called wet mixture is used to best advantage, so as to allow for evaporation. In cold weather, although heated water and heated sand may be used, there are more chances for freezing with wet than with dry mixtures, therefore a dry mixture is preferable.

The quantity of water varies also with the form and size of the mold. For molds of small dimensions, more water is required in order that the concrete may properly enter into all corners and surround the reinforcement. In molds of larger dimensions, the concrete can be more readily tamped.

*Journal of the Western Society of Engineers, Vol. VII, No. 3.

Other considerations influence the amount of water used: rich mixtures require more water than lean ones; fine sand requires more water than coarse; some crushed stone absorbs more water than others—and again, for water tanks, chimneys or manufactured articles, where a mixture of 1-4

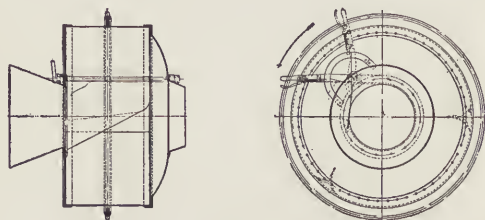

Fig. 1.—McKelvey Mixer

is used—and the aggregate generally consists of a very coarse sand, usually a very dry, hard rammed mixture is used.

A wet mix, in place of being tamped, is spaded or stirred by continuous working with a suitable tool. A dry mix is spaded only around the edges of the mold, but otherwise

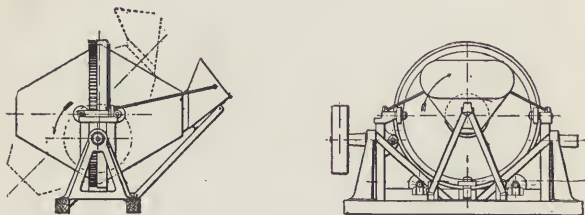

Fig. 2.—Smith Mixer.

tamped until a moisture appears on top of the concrete. European engineers are very successful with dry mixtures, but their success is due to the fact that the mixing and the placing are very carefully done. Their rule is to mix concrete moist enough to flow between the reinforcing members

and coat them with cement, but which will at the same time stand heavy ramming.

The Proper Consistency for Concrete.—This important factor is a matter of judgment and experience on the part of the engineer and contractor in charge and changes during a day's work according to local circumstances, dimensions of forms, shape of reinforcement, etc. The behavior of plastic concrete as it comes from the mixer, and especially while being tamped into place, will with a little practice enable one to judge if the amount of water is correct.

Hand or Machine Mixing.—Machine mixed concrete is superior in quality and generally less expensive than hand

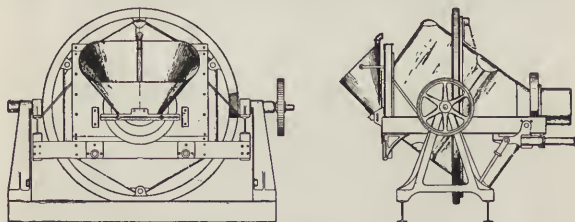

Fig. 3.—Chicago Improved Cube Mixer.

mixed. Mixing by hand is employed only when the quantity is small or when machinery is unobtainable.

Batch or Continuous Mixers.—For reinforced concrete, it has been conceded that batch mixing is preferable. In cases of very heavy construction, such as sea walls and breakwaters, locks, dams, etc., continuous mixers are used to advantage. Continuous mixing is cheaper and more rapid than batch mixing.

Classification of Batch Mixers.—The following classification of batch mixers is made by Mr. Clarence Coleman:*

(1) Revolving drum or cylinder with horizontal axis, with deflectors, receiving and discharging without stopping, concrete visible.

*Engineering News, Aug. 27, 1903.

(2) Revolving drum formed with two cones, with horizontal axis, deflectors, receiving and discharging without stopping, concrete visible.

(3) Revolving circular pan or trough, vertical axis, frame with radial arms, receiving and discharging without stopping, concrete visible.

(4) Horizontal revolving cylinder, mixes by revolving about axis, stops to receive and discharge, concrete invisible.

(5) Horizontal trough, semi-cylindrical cross-section, longitudinal shaft carrying blades, which mix the material and feed it toward the discharge end, receiving and discharging without stopping, concrete visible.

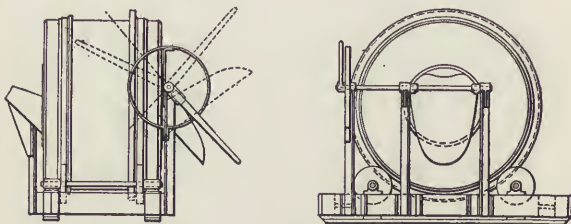

Fig. 4.—Ransome Mixer.

(6) Cubical box revolving about horizontal axis passing through two diagonally opposite corners, door at one side, stops to receive and discharge, concrete not visible.

(7) Same as above, except with corners through which axis passes cut away, tilts to discharge, receives and discharges without stopping, concrete visible.

Table of Batch Mixers.—Table VIII gives comparative sizes and capacities, and Figs. 1 to 4 illustrate several well known batch mixers. As in the case of rock crushers, however, the actual output which may be relied upon in long-time runs will average much lower than the rated capacity.

TABLE VIII.—BATCH MIXERS.

McKelvey Concrete Machinery Co., Cleveland, O.			Koehring Mixer. Koehring Machine Co., Milwaukee, Wis.			
Catalog No.	Size of Batch in cu. ft.	Capacity, yds. per hr.	Catalog No.	Size of Batch in cu. ft.	Capacity, yds. per hr.	
0	27	25	0—B	7	7	
2½	21	18	1—B	11	14	
6	13½	12	2—B	22	25	
7	9	7½	3—B	27	30	
8	4½	4½				
9	3	3				
Chicago Cube Mixer. Municipal Engineering & Contracting Co., Chicago.			Polygon Mixer. Waterloo Cement Machinery Co., Waterloo, Ia.			
"Handy"					Per day of 10 hrs.	
6	2½	5½	4	6	60	
11	6	13	5	10	100	
17	11	24	6	12	130	
22	17	40	7	16	180	
33	22	50				
64	33	70				
	64	120				
Ransome Concrete Machinery Co., New York.			Smith Mixer. The T. L. Smith Co., Chicago.			
			Catalog No.	Mixed dry.	Volume unmixed.	Yds. per hr.
1	10	10	0	6	8½	9
2	20	20	1	9	13	20
3	30	30	2	13½	20	30
4	40	40	2½	16½	24½	39
			4	22	34½	46
			5	30	46	62
R. Z. Snell Manufacturing Co., South Bend, Ind.			Chicago Concrete Machinery Co., Chicago.			
			00			
0	3	2½	0	3½	5	8
1	7	5	0	6	8½	14
2	11	8	1	9	13	21
3	24	20	2	18	26	42
Cropp Mixer. A. J. Cropp, Chicago.						
0	7 to 8	15				
1	10	20				
2	13	25				
3	16	30				
4	20	40				

Classification of Continuous Mixers.—They are classified as follows by Mr. Clarence Coleman:*

(1) Inclined chute fitted with pins, material slides down by gravity, concrete visible.

(2) Series of funnels placed one above another, containing baffles, concrete falls by gravity, invisible for most part.

TABLE IX.—CONTINUOUS MIXERS.

Scheffler Mixer. The Hartwick Machinery Co., Jackson, Mich.		Drake Mixer. Drake Standard Machine Works, Chicago.	
Catalog No.	Capacity per hour in cu. yds.	Catalog No.	Capacity per hour in cu. yds.
2	5	1	40
2½	8	2	20
3	12 to 15	3	15
		4	7.5
		4 Special	10
		5	2.5
Eureka Mixer. Eureka Machine Co., Lansing, Mich.		Foote Mixer. W. H. Wilcox Co., Binghamton, N. Y.	
81	10 to 12	1	6
82	10 to 18	2	7
83	10 to 18	2½	12
84	10 to 18	3	16
25	10 to 18	4	25
23	2 to 4		
Advance Mixer. Cement Machinery Co., Jackson, Mich.			
....	25 to 75		

(3) Long inclined box of square section, revolving on horizontal axis, concrete practically invisible.

(4) Like (3), except being cylindrical, with deflectors. Practically invisible.

*Engineering News, Aug. 27, 1903.

(5) Open trough or closed cylinder, fitted with shaft on which are paddles or blades which mix and feed concrete toward discharge end, concrete visible.

Table of Continuous Mixers.—Table IX gives comparative outputs of several well known continuous mixers.

Hains Gravity Mixer.—The Hains Concrete Mixer Co. of Washington, D. C., manufacture the mixer shown in Fig. 5. The charge passes successively through the hoppers.

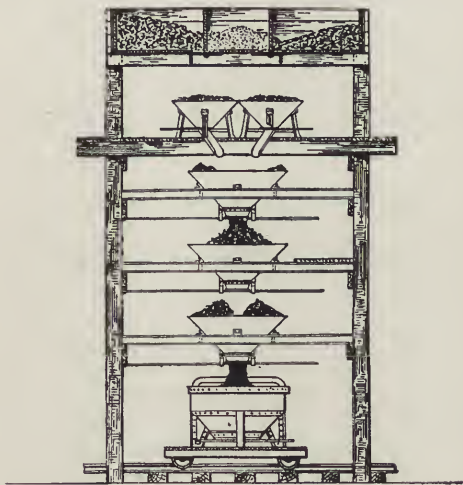

Fig. 5.—Hains Gravity Mixer, Fixed Hopper Form.

The four hoppers at the top have a combined capacity of one of the lower hoppers. Each top hopper is charged with cement, sand and stone in the order named and in the proper proportions. Water is then dashed over the tops of the filled hoppers and they are dumped simultaneously into the hopper next below. This hopper is then discharged into the next and so on to the bottom. Meanwhile the four top hoppers have been charged with materials for another batch. It

will be observed that (1) the concrete is mixed in separate batches, and (2) the ingredients making a batch are accurately proportioned and begin to be mixed at once for the whole batch. The best arrangement is to have the top of the hopper tower carry sand and stone bins which chute directly into the top hoppers.

STEEL.

While in Europe wrought iron is preferred for reinforcement, steel is used exclusively in the United States, both on account of lesser cost and on account of having more suitable qualities.

High or Low Carbon.—Engineers differ as to the qualities of steel desirable for reinforcement, some apprehension being entertained as to the brittleness of certain kinds of high carbon steel.

Open-hearth steel is decidedly preferable. High steel should have an ultimate strength of about 100,000 lbs. per sq. in., with an elastic limit averaging 54,000 lbs., with not more than 0.067 per cent of phosphorus, 0.06 per cent of sulphur and between 0.4 and 0.8 per cent of manganese, with 0.5 to 0.6 per cent of carbon, and showing 10 per cent elongation in 8 ins. for a test piece $\frac{3}{8}$ to $\frac{3}{4}$ in. in diameter, and a $\frac{1}{2}$ in. test piece should bend cold 110° around its own diameter without fracture.

Low carbon steel or soft steel should have an ultimate strength of from 54,000 to 62,000 lbs. per sq. in., with an elastic limit not less than one-half the ultimate strength. It should elongate 25 per cent in 8 ins. and bend cold 180° double without fracture on outside of bend.

Drawn steel wire of an ultimate strength of 156,000 lbs. per sq. in. has been used, with an elastic limit of from 90,000 to 126,000 lbs. in wire fabric and has shown many remarkable results.

For a medium steel of 32,000 to 35,000 lbs. elastic limit it is customary to specify a safe strength of 16,000 lbs. However, for steel wire of 90,000 to 126,000 lbs. the author has

never specified more than 30,000 lbs. as safe strength, owing to accidental effects by indentation in handling.

Owing to the fact that the coefficients of elasticity of high and low steel are very nearly equal, and hence the limit stretch only varies as 0.001 of the length for soft steel to 0.00167 of the length for high steel—and furthermore since, according to Prof. A. N. Talbot, the maximum allowable stretch of concrete lies near the point 0.001, it would appear that nothing could be gained by using a high carbon steel.* However, the author has since found that by using a high class concrete, of proportions such as 1 cement to 3 or 4 of aggregates proportioned for maximum density, far better results were obtained using high carbon steel than low carbon, and owing to lesser dimensions, a lower dead weight of floor slabs and girders has resulted, showing economy in spite of the fact that more expensive mixtures of the concrete were used, while taking advantage of the properties of high carbon steel.

Medium Steel.—When medium steel is used it should have an ultimate strength of from 60,000 to 68,000 lbs. per sq. in., with an elastic limit of not less than one-half the ultimate strength. It should elongate 22 per cent in 8 ins., and bend cold 180° around a diameter equal to the thickness of the test piece without fracture on outside of bend.

In the above bending tests for soft and medium steel the quality of metal should be such that it will stand the above described tests upon a test piece at least 5/16 in. in diameter, after being heated to a cherry red and cooled in water to a temperature of 70° F.

In reinforced concrete permissible working stresses are not based upon the ultimate strength of the steel, but upon the elastic limit, owing to the necessary adhesion between the concrete and the steel, which is apt to be destroyed by any reduction in the sectional area of the steel, such as occurs during the rapid elongation beyond the elastic limit.

*These conclusions were based upon extensive experiments made by Profs. Talbot, Hatt and Turneure with concrete mixtures of 1-2-4 and 1-3-6.

Percentage of Reinforcement.—With low carbon steel the percentage of reinforcement is from 1 to 1.4 per cent. With high carbon steel, the figures vary from 0.7 to 0.9 per cent

TABLE X.—WEIGHTS OF SQUARE AND ROUND RODS.

Calculated for steel, weighing 489.6 lbs. per cu. ft.
For iron, weighing 480 lbs. per cu. ft., subtract 2%.

Thickness or diameter in ins.	Wt. of ■ Bar in lbs. per ft.	Wt. of ● Rod in lbs. per foot.	Area of ■ Bar in sq. ins.	Area of ● Rod in sq. ins.	Circumfer- ence of ○ Rod in ins.
$\frac{1}{32}$.003	.003	.001	.0008	.0982
$\frac{1}{16}$.013	.010	.0039	.0031	.1964
$\frac{3}{32}$.030	.023	.0088	.0069	.2945
$\frac{1}{8}$.053	.042	.0156	.0123	.3927
$\frac{5}{32}$.083	.065	.0244	.0192	.4909
$\frac{3}{16}$.119	.094	.0352	.0276	.5891
$\frac{7}{32}$.163	.128	.0479	.0376	.6872
$\frac{1}{4}$.212	.167	.0625	.0491	.7854
$\frac{9}{32}$.269	.211	.0791	.0621	.8836
$\frac{5}{16}$.333	.261	.0977	.0767	.9818
$\frac{3}{8}$.402	.316	.1182	.0928	1.0799
$\frac{7}{16}$.478	.376	.1406	.1104	1.1781
$\frac{1}{2}$.561	.441	.1650	.1296	1.2763
$\frac{5}{8}$.651	.511	.1914	.1503	1.3745
$\frac{3}{4}$.747	.587	.2197	.1726	1.4726
$\frac{7}{8}$.850	.668	.2500	.1963	1.5708
$1\frac{1}{8}$.960	.754	.2822	.2217	1.6690
$1\frac{1}{4}$	1.076	.845	.3164	.2485	1.7672
$1\frac{3}{8}$	1.199	.941	.3525	.2769	1.8653
$1\frac{1}{2}$	1.328	1.043	.3906	.3068	1.9635
$1\frac{5}{8}$	1.464	1.150	.4307	.3382	2.0617
$1\frac{3}{4}$	1.607	1.262	.4727	.3712	2.1599
$1\frac{7}{8}$	1.756	1.380	.5166	.4057	2.2580
2	1.913	1.502	.5625	.4418	2.3562
$2\frac{1}{8}$	2.075	1.630	.6103	.4794	2.4544
$2\frac{1}{4}$	2.245	1.763	.6602	.5185	2.5526
$2\frac{3}{8}$	2.420	1.901	.7119	.5591	2.6507
$2\frac{1}{2}$	2.603	2.044	.7656	.6013	2.7489
$2\frac{5}{8}$	2.793	2.193	.8213	.6450	2.8471
$2\frac{3}{4}$	2.988	2.347	.8789	.6903	2.9453
$2\frac{7}{8}$	3.191	2.506	.9385	.7371	3.0434

of the cross section; thus it is seen that by using high carbon steel, there is only required from 0.64 to 0.7 as much reinforcing steel.

Mechanical Bond.—Mechanical bond is obtained by deformed rods, supplementary rods, stirrups or anchors. Such bond is absolutely necessary where a lean concrete is used, in which the adhesion between steel and concrete has a low

TABLE X. (Continued)—WEIGHTS OF SQUARE AND ROUND RODS.

Thickness or diameter in ins.	Wt. of ■ Bar in lbs. per ft.	Wt. of ● Rod in lbs. per foot.	Area of ■ Bar in sq. ins.	Area of ● Rod in sq. ins.	Circumference of O Rod in ins.
1	3.400	2.670	1.0000	.7854	3.1416
$\frac{1}{16}$	3.838	3.015	1.1289	.8866	3.3380
$\frac{3}{16}$	4.303	3.380	1.2656	.9940	3.5343
$\frac{1}{8}$	4.795	3.766	1.4102	1.1075	3.7306
$\frac{1}{4}$	5.312	4.172	1.5625	1.2272	3.9270
$\frac{5}{16}$	5.857	4.600	1.7227	1.3530	4.1234
$\frac{3}{8}$	6.428	5.049	1.8936	1.4849	4.3197
$\frac{7}{16}$	7.026	5.518	2.0664	1.6230	4.5161
$\frac{1}{2}$	7.650	6.008	2.2500	1.7671	4.7124
$\frac{9}{16}$	8.301	6.519	2.4414	1.9175	4.9088
$\frac{5}{8}$	8.978	7.051	2.6406	2.0739	5.1051
$\frac{11}{16}$	9.682	7.604	2.8477	2.2365	5.3015
$\frac{3}{4}$	10.404	8.178	3.0625	2.4053	5.4978
$\frac{13}{16}$	11.169	8.773	3.2852	2.5802	5.6942
$\frac{7}{8}$	11.953	9.388	3.5156	2.7612	5.8905
$\frac{15}{16}$	12.763	10.024	3.7539	2.9483	6.0869
2	13.60	10.68	4.0000	3.1416	6.2832
$\frac{1}{16}$	14.46	11.36	4.2539	3.3410	6.4796
$\frac{3}{16}$	15.35	12.06	4.5156	3.5466	6.6759
$\frac{1}{8}$	16.27	12.78	4.7852	3.7583	6.8723
$\frac{1}{4}$	17.21	13.52	5.0625	3.9761	7.0686
$\frac{5}{16}$	18.18	14.28	5.3477	4.2000	7.2650
$\frac{3}{8}$	19.18	15.06	5.6406	4.4301	7.4613
$\frac{7}{16}$	20.20	15.87	5.9414	4.6664	7.6577
$\frac{1}{2}$	21.25	16.69	6.2500	4.9087	7.8540
$\frac{9}{16}$	22.33	17.53	6.5664	5.1573	8.0504
$\frac{5}{8}$	23.43	18.40	6.8906	5.4119	8.2467
$\frac{11}{16}$	24.56	19.29	7.2227	5.6727	8.4431
$\frac{3}{4}$	25.71	20.19	7.5625	5.9396	8.6394
$\frac{13}{16}$	26.90	21.12	7.9102	6.2126	8.8358
$\frac{7}{8}$	28.10	22.07	8.2656	6.4918	9.0321
$\frac{15}{16}$	29.34	23.04	8.6289	6.7771	9.2285
3	30.60	24.03	9.0000	7.0686	9.4248

value. But for a rich concrete or mortar, such as is largely used in Europe and is coming into use in the United States, mechanical bond can be dispensed with, except for girders,

beams, columns, etc., where it simply becomes a matter of calculation. See Building Design.

Reinforcing Steel.—There are a great many styles and

TABLE XI.—AREAS OF FLAT ROLLED STEEL.

For thicknesses, from $\frac{1}{16}$ in. to 1 in., and widths from $\frac{1}{4}$ in. to 4 in.

Thickness in Ins.	$\frac{1}{4}$ "	$\frac{1}{2}$ "	$\frac{3}{4}$ "	1"	1 $\frac{1}{4}$ "	1 $\frac{1}{2}$ "	1 $\frac{3}{4}$ "	2"
$\frac{1}{16}$.016	.031	.047	.063	.078	.094	.109	.125
$\frac{1}{8}$.031	.063	.094	.125	.156	.188	.219	.250
$\frac{3}{16}$.047	.094	.141	.188	.234	.281	.328	.375
$\frac{1}{4}$.063	.125	.188	.250	.313	.375	.438	.500
$\frac{5}{16}$.078	.156	.234	.313	.391	.469	.547	.625
$\frac{3}{8}$.094	.188	.281	.375	.469	.563	.656	.750
$\frac{7}{16}$.109	.219	.328	.438	.547	.656	.766	.875
$\frac{1}{2}$.125	.250	.375	.500	.625	.750	.875	1.00
$\frac{9}{16}$.141	.281	.422	.563	.703	.844	.984	1.13
$\frac{5}{8}$.156	.313	.469	.625	.781	.938	1.09	1.25
$\frac{11}{16}$.172	.344	.516	.688	.859	1.03	1.20	1.38
$\frac{3}{4}$.188	.375	.563	.750	.938	1.13	1.31	1.50
$\frac{13}{16}$.203	.406	.609	.813	1.02	1.22	1.42	1.63
$\frac{7}{8}$.219	.438	.656	.875	1.09	1.31	1.53	1.75
$\frac{15}{16}$.234	.469	.703	.938	1.17	1.41	1.64	1.88
1	.250	.500	.750	1.000	1.25	1.50	1.75	2.00

TABLE XII.—WEIGHTS OF FLAT ROLLED STEEL, PER LINEAL FOOT.
One cubic foot weighing 489.6 pounds.

Thickness in Ins.	$\frac{1}{4}$ "	$\frac{1}{2}$ "	$\frac{3}{4}$ "	1"	1 $\frac{1}{4}$ "	1 $\frac{1}{2}$ "	1 $\frac{3}{4}$ "	2"
$\frac{1}{16}$.053	.106	.159	.213	.266	.319	.372	.425
$\frac{1}{8}$.106	.213	.319	.425	.531	.638	.744	.850
$\frac{3}{16}$.159	.319	.478	.638	.797	.956	1.12	1.28
$\frac{1}{4}$.213	.425	.638	.850	1.06	1.28	1.49	1.70
$\frac{5}{16}$.266	.531	.797	1.06	1.33	1.59	1.86	2.12
$\frac{3}{8}$.319	.638	.956	1.28	1.59	1.91	2.23	2.55
$\frac{7}{16}$.372	.744	1.12	1.49	1.86	2.23	2.60	2.98
$\frac{1}{2}$.425	.850	1.28	1.70	2.13	2.55	2.98	3.40
$\frac{9}{16}$.478	.956	1.43	1.91	2.39	2.87	3.35	3.83
$\frac{5}{8}$.531	1.06	1.59	2.13	2.66	3.19	3.72	4.25
$\frac{11}{16}$.584	1.17	1.75	2.34	2.92	3.51	4.09	4.68
$\frac{3}{4}$.638	1.28	1.91	2.55	3.19	3.83	4.46	5.10
$\frac{13}{16}$.691	1.38	2.07	2.76	3.45	4.14	4.83	5.53
$\frac{7}{8}$.744	1.49	2.23	2.98	3.72	4.46	5.21	5.95
$\frac{15}{16}$.797	1.59	2.39	3.19	3.98	4.78	5.58	6.38
1	.850	1.70	2.55	3.40	4.25	5.10	5.95	6.80

kinds of steel in use for reinforcing concrete, which may be classified as loose rods, expanded metal, fabrics, beam and girder units, column reinforcements, and structural steel.

TABLE XI. (Continued).—AREAS OF FLAT ROLLED STEEL.
For thicknesses, from $\frac{1}{8}$ in. to 1 in., and widths from $\frac{1}{2}$ in. to 4 in.

Thickness in Ins.	2 1/2"	2 1/2"	2 1/2"	3"	3 1/2"	3 1/2"	3 1/2"	4"
$\frac{1}{16}$.141	.156	.172	.188	.203	.219	.234	.250
$\frac{1}{8}$.281	.313	.344	.375	.406	.438	.469	.500
$\frac{3}{16}$.422	.469	.516	.563	.609	.656	.703	.750
$\frac{1}{4}$.563	.625	.688	.750	.813	.875	.938	1.00
$\frac{5}{16}$.703	.781	.859	.938	1.02	1.09	1.17	1.25
$\frac{3}{8}$.844	.938	1.03	1.13	1.22	1.31	1.41	1.50
$\frac{7}{16}$.984	1.09	1.20	1.31	1.42	1.53	1.64	1.75
$\frac{1}{2}$	1.13	1.25	1.38	1.50	1.63	1.75	1.88	2.00
$\frac{9}{16}$	1.27	1.41	1.55	1.69	1.83	1.97	2.11	2.25
$\frac{5}{8}$	1.41	1.56	1.72	1.88	2.03	2.19	2.34	2.50
$\frac{11}{16}$	1.55	1.72	1.89	2.06	2.23	2.41	2.58	2.75
$\frac{3}{4}$	1.69	1.88	2.06	2.25	2.44	2.63	2.81	3.00
$\frac{7}{8}$	1.83	2.03	2.23	2.44	2.64	2.84	3.05	3.25
$\frac{15}{16}$	1.97	2.19	2.41	2.63	2.84	3.06	3.28	3.50
$\frac{1}{8}$	2.11	2.34	2.58	2.81	3.05	3.28	3.52	3.75
1	2.25	2.50	2.75	3.00	3.25	3.50	3.75	4.00

TABLE XII. (Continued).—WEIGHTS OF FLAT ROLLED STEEL.
One cubic foot weighing 489.6 pounds.

Thickness in Ins.	2 1/2"	2 1/2"	2 1/2"	3"	3 1/2"	3 1/2"	3 1/2"	4"
$\frac{1}{16}$.478	.531	.584	.638	.691	.744	.797	.850
$\frac{1}{8}$.956	1.06	1.17	1.28	1.38	1.49	1.59	1.70
$\frac{3}{16}$	1.43	1.59	1.75	1.91	2.07	2.23	2.39	2.55
$\frac{1}{4}$	1.91	2.13	2.34	2.55	2.76	2.98	3.19	3.40
$\frac{5}{16}$	2.39	2.66	2.92	3.19	3.45	3.72	3.98	4.25
$\frac{3}{8}$	2.87	3.19	3.51	3.83	4.14	4.46	4.78	5.10
$\frac{7}{16}$	3.35	3.72	4.09	4.46	4.83	5.21	5.58	5.95
$\frac{1}{2}$	3.83	4.25	4.68	5.10	5.53	5.95	6.38	6.80
$\frac{9}{16}$	4.30	4.78	5.26	5.74	6.22	6.69	7.17	7.65
$\frac{5}{8}$	4.78	5.31	5.84	6.38	6.91	7.44	7.97	8.50
$\frac{11}{16}$	5.26	5.84	6.43	7.02	7.60	8.18	8.76	9.35
$\frac{3}{4}$	5.74	6.38	7.02	7.65	8.29	8.93	9.57	10.20
$\frac{7}{8}$	6.22	6.91	7.60	8.29	8.98	9.67	10.36	11.05
$\frac{15}{16}$	6.69	7.44	8.18	8.93	9.67	10.41	11.16	11.90
$\frac{1}{8}$	7.17	7.97	8.76	9.57	10.36	11.16	11.95	12.75
1	7.65	8.50	9.35	10.20	11.05	11.90	12.75	13.60

Loose Rods for Reinforcing.—These comprise round rods, square and flat bars, and the various patented deformed bars. Owing to the fact that in the United States nearly all the building regulations or ordinances require a mechanical bond, and specify or permit such concrete mixtures as will require it, tables are here inserted showing the properties of several of the most popular forms of reinforcement based upon the principle of mechanical bond.

There are a number of prominent systems of construction that are built up of loose rods, the assembling being done in the field. Practically all reinforced concrete work abroad comes under this classification, and formerly, loose rod systems were the only ones used in America. If loose rods are used for reinforcing instead of built up units, greater freedom is allowed in adapting the reinforcing material to the part of the structure in which it is located. A number of prominent systems of reinforcement which are built of loose rods, will be given further on.

Square Bars and Round Rods.—The first form of reinforcing steel to be used was plain round rods, and these will always find favor with engineers, regardless of the number of patent deformed bars which are invented. Plain round rods and square bars have the advantage that they are always easily obtained, they are easy to handle, and with care will give as good results as any other form of reinforcing steel. This is amply demonstrated by the great number of examples of reinforced concrete work abroad in which nothing but plain round rods are used.

For years after the introduction of reinforced concrete into France, Germany and elsewhere, there were no deformed bars in use, and it is chiefly in America that they are given prominence. This will be readily seen by referring to the illustrations of foreign methods of construction.

Weights and Areas of Twisted Bars.—Twisted bars, Fig. 6, are not covered by patent and can be obtained in open market. These bars are square in section, so that, for a

given thickness, the weights and areas correspond with those for plain square bars. Table XIII, for twisted bars, is based upon steel weighing 489.6 lbs. per cu. ft.



Fig. 6.—Twisted Bar.

TABLE XIII.—WEIGHTS AND AREAS OF TWISTED BARS.

Thickness of section in ins.	Weight in lbs. per ft.	Area of section in sq. ins.
$\frac{1}{4}$	0.212	0.063
$\frac{3}{8}$	0.478	0.141
$\frac{1}{2}$	0.85	0.25
$\frac{5}{8}$	1.32	0.391
$\frac{3}{4}$	1.91	0.563
$\frac{7}{8}$	2.60	0.765
1	3.4	1.000
$1\frac{1}{8}$	4.3	1.266
$1\frac{1}{4}$	5.3	1.563

Weights and Areas of Corrugated Bars.—New-style corrugated bars, Fig. 7, are patented, and can be obtained from



Fig. 7.—New Style Corrugated Bar.

TABLE XIV.—WEIGHTS AND AREAS OF NEW STYLE CORRUGATED BARS.

Thickness of section in ins.	Weight in lbs. per ft.	Area of section in sq. ins.
$\frac{1}{4}$	0.24	0.06
$\frac{1}{2}$	0.85	0.25
$\frac{5}{8}$	1.33	0.39
$\frac{3}{4}$	1.91	0.56
$\frac{7}{8}$	2.60	0.77
1	3.40	1.00
$1\frac{1}{4}$	5.31	1.56

the Expanded Metal & Corrugated Bar Company, St. Louis, Mo. These bars are square in section, so that their weights and areas are like those of square bars of the same thickness. See Table XIV. The universal corrugated bar shown by Fig. 8 is made by the same firm; its dimensions, area, etc., are shown by Table XV.



Fig. 8.—Universal Corrugated Bar.

TABLE XV.—WEIGHT AND AREAS OF UNIVERSAL CORRUGATED BARS.

No.	Size.	Net section in sq. ins.	Wt. in lbs. per ft.
1	$\frac{1}{2}$ x 1	0.19	0.73
2	$\frac{5}{8}$ x $1\frac{1}{2}$	0.32	1.18
3	x 1	0.41	1.35
4	x $1\frac{1}{2}$	0.54	1.97
5	x 2	0.65	2.27
6	x $2\frac{1}{2}$	0.80	2.85

Weights and Areas of Diamond Bars.—Diamond bars, Fig. 9, are patented and can be obtained from the Concrete-



Fig. 9.—Diamond Bar.

TABLE XVI.—WEIGHTS AND AREAS OF DIAMOND BARS.

Size in ins.	Weight in lbs. per ft.	Area of section in sq. ins.
$\frac{1}{2}$.85	.25
$\frac{5}{8}$	1.33	.39
$\frac{3}{4}$	1.91	.56
1	2.60	.76
$1\frac{1}{4}$	3.40	1.00
$1\frac{1}{2}$	5.31	1.56

Steel Engineering Company, New York city. Their sectional areas and weights correspond with standard sizes of square bars, and are shown in Table XVI.

Thacher Bars.—Thacher bars, Fig. 10, are patented, and can be obtained from the Concrete-Steel Engineering Co., New York. At No. 1 mill, round bars are reheated and re-rolled to the finished shape. At No. 2 mill, bars are rolled to the finished shape without reheating. Variations in rolling are from 2½ to 5 per cent. The manufacturers advocate the use of medium steel, but supply both Diamond and Thacher bars in high and low carbon steel.



Fig. 10.—Thacher Bar.

TABLE XVII.—WEIGHTS AND AREAS OF THACHER BARS.

Nominal diameter, ins.	No. 1 Mill		No. 2 Mill	
	Area, sq. in.	Weight per lin. ft.	Area, sq. in.	Weight per lin. ft.
1	0.047	0.16
	0.10	0.34
	0.18	0.61	0.17	0.58
	0.28	0.95	0.27	0.92
	0.41	1.39	0.39	1.34
	0.55	1.87	0.53	1.79
1	0.71	2.42	0.68	2.32
1½	0.90	3.06
1½	1.10	3.74	1.04	3.55
1½	1.32	4.49
1½	1.56	5.30	1.53	5.20
1	1.81	6.16
1	2.08	7.07
1	2.35	8.00
2	2.65	9.02

Weights and Areas of Monolith Steel Bars.—The monolith bar shown by Fig. 11 is made by the Monolith Steel Co., Washington, D. C. The properties of this bar are shown in Table XVIII.

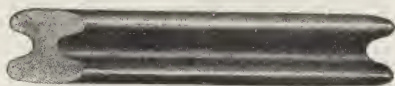

Fig. 11.—Monolith Bar.

TABLE XVIII.—WEIGHTS AND AREAS OF MONOLITH BARS.

Designation.	Area of section in sq. ins.	Side of Equivalent square.	Approximate weight in lbs. per ft.	Maximum Length in ft.	Diameter of Corresponding web member in ins.
1½"	2.25	1.5	7.75	50	
1"	1.00	1.0	3.37	50	
8"	0.64	0.8	2.18	50	
¾"	0.25	0.5	0.85	60	
¾"	0.16	0.4	0.55	40	

The last column of the above table refers to the web members which fit into the grooves at the sides. These web members are shown in the illustration of this bar under Girder Reinforcement.

Cup Bars.—The cup bar shown by Fig. 12 is made by the Trussed Concrete Steel Co., Detroit, Mich. The depressions

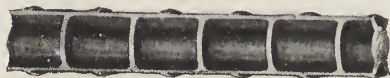

Fig. 12.—Cup Bar.

on the bar are for the purpose of furnishing a mechanical bond. Table XIX gives sizes and weights.

TABLE XIX.—SIZES AND WEIGHTS OF CUP BARS.

Size, ins.	Weight, lbs. per ft.	Size, ins.	Weight, lbs. per ft.
$\frac{1}{2}$ $\frac{3}{4}$ 1 $1\frac{1}{4}$	0.48	$\frac{7}{8}$ 1 $1\frac{1}{8}$ $1\frac{1}{4}$	2.55
	0.86		3.46
	1.35		4.38
	1.95		4.51

Twisted Lug Bar.—This bar, shown in Fig 13, is manufactured by the General Fireproofing Co., Youngstown, O. The lugs are to assist the twisted section in securing a firm grip on the concrete and resist any tendency on the part of the bar to untwist under tension. Weights and area are shown in Table XX.



Fig. 13.—Twisted Lug Bar.

TABLE XX.—WEIGHTS AND AREAS OF TWISTED LUG BARS.

Size, ins.	Weight, lbs. per ft.	Area sq. ins.
$\frac{1}{2}$ $\frac{3}{4}$ 1 $1\frac{1}{4}$ $1\frac{1}{2}$ $1\frac{3}{4}$ 2	0.222	0.625
	0.87	0.250
	1.35	0.3906
	1.94	0.5625
	2.64	0.7656
	3.45	1.00
	5.37	1.5625
7.70	2.25	

TABLE XXI.—WIRE GAGES.

No.	Birmingham or Stubs' Wire Gage.			Browne & Sharpe's or American Wire Gage.			No.
	Diameter in Ins.	Area in Sq. Ins.	Weight per foot.*	Diameter in Ins.	Area in Sq. Ins.	Weight per foot.*	
4	.238	.0445	.1483	.20431	.0328	.1093	4
5	.220	.0380	.1267	.18194	.0260	.0867	5
6	.203	.0324	.1079	.16202	.0206	.0687	6
7	.180	.0254	.0848	.14428	.0163	.0545	7
8	.165	.0214	.0713	.12849	.0129	.0432	8
9	.148	.0172	.0573	.11442	.0103	.0343	9
10	.134	.0141	.0470	.10189	.0081	.0272	10
11	.120	.0113	.0377	.09074	.0065	.0215	11
12	.109	.0093	.0310	.08081	.0051	.0171	12
13	.095	.0071	.0236	.07196	.0041	.0135	13
14	.083	.0054	.0180	.06408	.0032	.0107	14
15	.072	.0041	.0136	.05706	.0025	.0085	15
16	.065	.0033	.0111	.05082	.0020	.0067	16
17	.058	.0026	.0088	.04525	.0016	.0054	17
18	.049	.0019	.0063	.04030	.0013	.0042	18
19	.042	.0014	.0046	.03589	.0010	.0034	19
20	.035	.00096	.00321	.03196	.0008	.0027	20
21	.032	.00080	.00268	.02846	.00063	.0021	21
22	.028	.00061	.00235	.02535	.00050	.0017	22

Within the limits of this table, the gage numbers for the American Steel & Wire Co., the Roebling Sons Co., and the Trenton Iron Co., do not differ materially from the Birmingham gage.

*Weights calculated for iron wire weighing 480 lbs. per cu. ft. For steel wire (weighing 489.6 lbs. per cu. ft.) multiply these values by 1.02.

Wire Fabric.—This material has come into almost universal use and has been found to possess many valuable, even indispensable qualities. Its advantages are that it prevents temperature cracks and also prevents cracks from shocks. A building having fabric in walls, floors, girders, beams, columns, and resting on a mat foundation can withstand unequal loading, treacherous subsoil, excessive wind pressure, fire and even seismic disturbances much better than any other structure known to the technical world.

Wire fabric is made of steel wires crossing at right angles and secured at the intersections. The heavier wires run lengthwise and are called carrying wires; the lighter ones

cross these and are called distributing or tie wires. The manner of securing the intersections has given rise to a number of different types of wire fabric, several of the principal ones of which are given below. The manufacturers of each of these forms will furnish fabric in special size of wire and mesh if desired.

Tie-Locked Fabric.—Tie-locked fabric, Fig. 14, is manufactured by the International Fence & Fireproofing Co., Columbus, O., in stock lengths of 200 ft., and stock widths of 4 and 5 ft., as shown by Table XXII.

TABLE XXII.—GAGE AND MESH OF TIE LOCKED FABRIC.

No.	Gage of Carrying Wire	Gage of Tie Wire.	Mesh in inches.
A-1	9	11	6 x 6
A-2	9	11	5 x 6
A-3	9	11	4 x 6
B-1	7	9	6 x 6
B-2	7	9	5 x 6
B-3	7	9	4 x 6

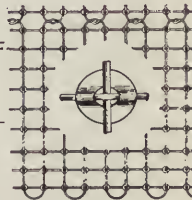

Fig. 14.—Tie-locked Fabric.

Lock-Woven Fabric.—Lock-woven fabric, Fig. 15, is manufactured by W. N. Wight & Co., New York. The wires are from No. 3 to No. 12 gage, commonly woven in 4x6-in. mesh, 56 ins. wide and 300 ft. long.

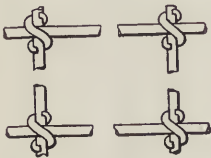

Fig. 15.—Lock-woven Fabric.

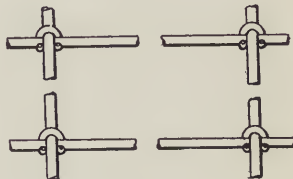

Fig. 16.—American Wire Fabric.

American Wire Fabric.—American wire fabric, Fig. 16, is of high carbon steel wires, secured at the intersections by No. 14 wire, and manufactured by the American Wire Fence Co., Chicago. Standard sizes are shown by Table XXIII.

TABLE XXIII.—GAGE AND MESH OF AMERICAN WIRE FABRIC.

Gage of Carrying Wires.	Gage of Distributing Wires.	Mesh in Inches.
9	11	4 x 12
9	11	4 x 6
9	11	6 x 6
7	11	4 x 12
7	11	4 x 6
7	11	6 x 6

Welded Wire Fabric.—Welded wire fabric, Fig. 17, has the intersections electrically welded and is manufactured by the Clinton Wire Cloth Co., Clinton, Mass., in a variety of meshes—the longitudinals spaced in steps of $\frac{1}{2}$ in. and the transverse wires in steps of 1 in.

TABLE XXIV.—WEIGHT AND STRENGTH OF WELDED WIRE FABRIC.



Fig. 17.—Welded Wire Fabric.

Gage W. & M. No.	Diameter of One Wire in ins.	Wt. per Lineal Foot of One Wire in lbs.	Tensile Strength of One Wire in lbs.
0	.3065	.2506	4,427
1	.2830	.2136	3,774
2	.2625	.1838	3,247
3	.2437	.1584	2,799
4	.2253	.1354	2,392
5	.2070	.1143	2,019
6	.1920	.0983	1,737
7	.1770	.0835	1,476
8	.1620	.0700	1,237
9	.1483	.0586	1,036
10	.1350	.0486	859
11	.1205	.0387	684
12	.1055	.0296	524

The following figures* show a comparison between two kinds of wire as to breaking loads:

*By Lorin E. Hunt, C. E., Berkeley, Cal.

	Diameter in inches	Breaking load in lbs.	Load per sq. in.
Welded Fabric No. 8.....	0.163	1,510	72,300
Welded Fabric No. 6.....	0.191	1,860	64,900
American System No. 3.....	0.146	2,292	136,900
American System No. 7.....	0.175	3,060	127,100

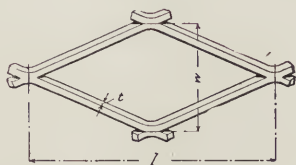

Fig. 18.—Expanded Metal.

Expanded Metal.—Expanded metal, Fig. 18, is a mesh formed from a sheet of soft steel by slitting and opening or expanding the metal with meshes in direction normal to the axis of the sheet. Table XXV is compiled from information furnished by the Associated Expanded Metal Companies, New York.

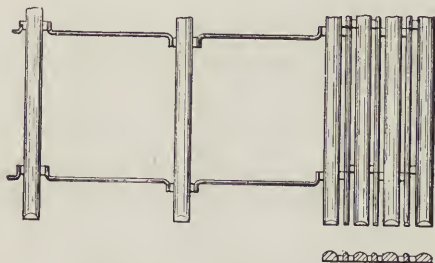

Fig. 19.—Kahn Rib Metal

Kahn Rib Metal.—This material, Fig. 19, is made from a sheet of metal, flat on one side and corrugated on the other. Strips of the metal adjacent to the ribs are stamped out, and the sheet is drawn out into square meshes. The illustration shows these points and Table XXVI gives the properties of

this material. It is manufactured by the Trussed Concrete Steel Co., Detroit, Mich.

TABLE XXV.—EXPANDED METAL MESHES.

Mesh in ins.	Designation		Size of Mesh		Strand	Secti'n in sq. in. per foot of width	Wt. in lbs per sq. ft.	Size of standard sheets, in feet Width by length	No. of sheets in a bundle	No. of sq. ft. in bun- dle of 8 ft. length
	Gage, stubs.	Thick- ness in ins. <i>t</i>	Width center to center in ins. <i>w</i>	Leng'h center to center in ins. <i>l</i>						
1 2 3 3 3 3 3 3 3 3 3 3 3 3 3 3	18	0.049 ⁶	0.43	1.2	Standard	.209	.74	3 or 6 x 8	5	120
	13	0.095	0.95	2.0	"	.225	.80	6 x 8 or 12	5	240
	12	0.109	1.36	3.0	"	.207	.70	4 x 8 or 12	5	160
	12	0.109	1.82	4.0	"	.166	.56	5 x 8 or 12	5	200
	16	0.065	3.00	8.0	"	.083	.28	6 x 8 or 12	10	480
	10	0.134	3.0	8.0	Light	.148	.50	5 1/2 x 8 or 12	5	210
	10	0.134	3.0	8.0	Standard	.178	.60	6 x 8 or 12	5	240
	10	0.134	3.0	8.0	Heavy	.267	.90	4 x 8 or 12	5	160
	10	0.134	3.0	8.0	Ex. Heavy	.356	1.20	6 x 8 or 12	3	144
	6	0.203	3.0	8.0	Standard	.400	1.38	5 x 8 or 12	3	120
	6	0.203	3.0	8.0	Heavy	.600	2.07	5 x 8 or 12	3	120
	16	0.065	3.86	6.85	Old Style	.093	.42	4 1/2 x 8 or 9	6	206
	4	0.238	6.0	16.0	Standard	.245	.84	5 x 8 or 12	5	200
	4	0.238	6.0	16.0	Heavy	.368	1.26	5 x 8 or 12	3	120

LATHING.

Designation	Size of Mesh		Gage U. S. Stand- ard	Thick- ness inches <i>t</i>	Size of sheets in feet	Sheets in a bundle	Sq. yds. in a bundle	Wt. in lbs. per sq. yd.
	Width center to center in inches <i>w</i>	Leng'h center to center in inches <i>l</i>						
A	*0.40	*2.0	24	.025	18 x 96	9	12.	4.00
B	*0.40	*2.0	27	.0171875	18 x 96	15	20.	2.90
BB	*0.60	2.0	27	.0171875	22 x 96	15	24.44	2.33
Diamond, No. 2 1/2	0.41	1.2	24	.025	18 x 96	15	20.	3.75
Diamond, No. 26	0.41	1.2	26	.01875	24 x 96	9	16.	2.66

*The meshes of "A" and "B" lath are parallelograms, the sides being 0.6x1.5 ins. on centers, and the perpendicular distance between centers of long sides is about 0.4 in. "BB" lath is practically the same as "B" except meshes are wider. The tensile strength of the uncut sheet is 16,000 lbs. per sq. in.

TABLE XXVI.—PROPERTIES OF KAHN RIB METAL.

Size No.	Distance center to center of bars, in ins.	Sect. area in sq. ins. per ft. in width	Width of sheets ins.	Sq. ft. in sheet 12 ft. long	Safe tensile stress, lbs.	Ultimate strength	Weight, lbs. per sq. ft.
2	2	0.54	17	17	9,700	38,800	2.13
3	3	0.36	25	25	6,480	25,920	1.43
4	4	0.27	33	33	4,860	19,440	1.08
5	5	0.22	41	41	3,960	15,840	0.87
6	6	0.18	49	49	3,240	12,960	0.72
7	7	0.15	57	57	2,700	10,800	0.62
8	8	0.14	65	65	2,520	10,080	0.55

NOTE.—Area of each rib is 0.08 sq. in. Standard lengths of sheets are 12, 14 and 16 ft.

Beam and Girder Units.—There are several forms of beam or girder reinforcement which are either in one piece or assembled together as one unit, the steel being placed along the planes of greatest stress. A number of the best known forms are given below. In nearly all of these built-up forms, deformed bars can be used instead of plain rods, according to the choice of the engineer.

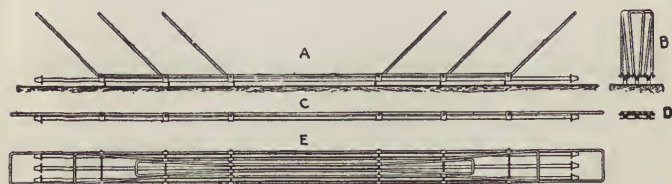

Fig. 20.—Cummings Girder Frame.

Cummings Girder Frame.—The Cummings trussed girder reinforcement is arranged as a framed system by the introduction of hoop iron chair-clamps around all rods where one of them is bent up. The rods are shipped flat to the building for the sake of convenience, as shown at C, D and E, Fig. 20. The prongs are bent up at 45 degrees (as at A) on the floor before the frame is set in the mold, the chairs

further serving to keep the bars at proper distance from the molds.

"Unit" Frame.—The Unit concrete-steel frame, Fig. 21, has the reinforcing rods and stirrups rigidly held together by a unit socket support, which latter also serves the purpose of receiving hanger bolts or other appliances that are



Fig. 21.—Unit Frame.

to be suspended to the girder afterwards. They are handled by Tucker & Vinton, New York.

Kahn Trussed Bar.—The Kahn trussed bar, Fig. 22, named for its inventor, is a form of beam, girder or column reinforcement, consisting of a special rolled section of steel with diagonal members sheared up at 45° on both sides of the main body. For continuous beams, inverted bars are

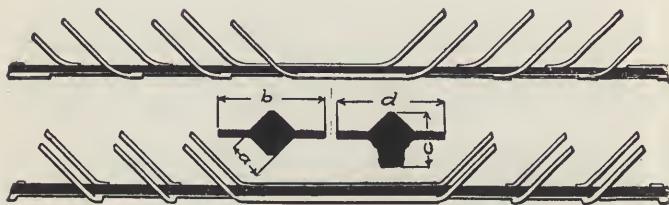

Fig. 22.—Kahn Trussed Bar.

placed over the supports in the upper part of the beam, extending over the region of tension. These bars are of two forms of section, as shown by Fig. 22, and either form may be sheared alternately or opposite with varying lengths of diagonal. They are manufactured by the Trussed Concrete Steel Co., Detroit, Mich.

TABLE XXVII.—PROPERTIES OF KAHN TRUSSED BARS.

Size in ins. <i>a x b</i>	Weight in lbs. per ft.	Area of un-sheared bar in sq. ins.	Area of sheared bar in sq. ins.	Shear value of one diagon ^l in lbs. per sq. in.	Tensile strength of bar in lbs. per sq. in.		Length of Diagonals in ins.		
		Gross.	Net.		Un-sheared.	Sheared.	Stand-ard.	Special.	
Square Section Bars.									
$1\frac{1}{2} \times 1\frac{1}{2}$	1.4	.41	.25	900	6,600	4,000	6	..	
$1\frac{3}{4} \times 2\frac{1}{4}$	2.7	.79	.56	1,300	12,600	9,000	12	8	
1×3	4.8	1.41	1.00	2,300	22,600	16,000	24	18	
$1\frac{1}{2} \times 3\frac{1}{2}$	6.8	2.00	1.60	2,300	32,000	25,600	24	18 30	
New Section Bars.									
$1\frac{3}{4} \times 2\frac{3}{4}$	6.8	2.00	1.60	2,300	32,000	25,600	24	30	
$2 \times 3\frac{1}{2}$	10.2	3.00	2.40	3,400	48,000	38,400	24	18 30	

NOTE.—6, 8 and 12 in. diagonals are sheared opposite. 18, 24 and 30 in. diagonals are sheared alternately.

Luten Truss.—The Luten truss is clamped and locked in a rigid unit by means of a clamp with a wedge that is self-locking when tightly driven in. The truss and one of the clamps in position are shown by Fig. 23. This truss is to be obtained from the National Concrete Co., Indianapolis, Ind.



Fig. 23.—Luten Truss.

Monolith Frame.—The monolith bar frame for reinforcing beams and girders is shown by Fig. 24. The web mem-

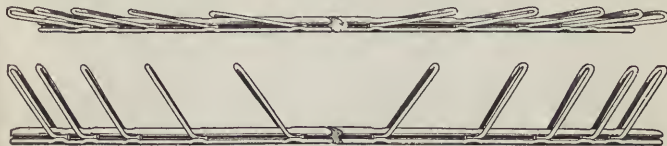

Fig. 24.—Monolith Frame.

bers are secured within the grooves by pressure. Sizes of bars with corresponding webs are given in Table XVIII. The two views show the bar with web members attached, ready for transportation, and the bar with web members raised, ready for use. The lifting of the webs is done quickly by means of a hand sprocket tool which sets them at the correct angle. This bar is sold by the Monolith Steel Co., Washington, D. C.

Pin-Connected Girder Frame.—Pin-connected girder frames are made by the General Fireproofing Co., Youngstown, O. The construction is shown by Fig. 25.

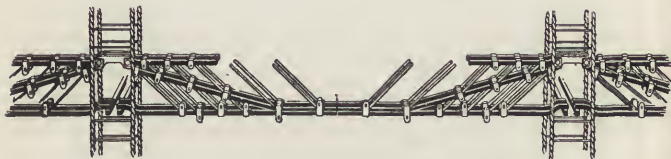

Fig. 25.—Pin-Connected Girder Frame.

Hooped Column Reinforcement.—While there are several types of reinforced concrete column constructed, almost the only assembled units on the market are those for hooped columns, since the other types of column reinforcement are assembled in the field from loose rods. As with wire fabrics and girder units, the main points of difference in hooped column reinforcements are the methods of fastening. The hoops may be arranged either as a spiral or as annular rings, and the hooping material may be either flat band steel or wires. The longitudinal reinforcement may be part of the hooping unit or separate rods may be inserted. The superior advantages of hooped columns over other forms are referred to under Design.

Cummings Hooped Column.—The Cummings hooped column, invented by Mr. Robert A. Cummings, is shown by Fig. 26. Table XXVIII gives the safe loads. This column

reinforcement is built up of annular hoops made of flat steel bent to a circle with the ends riveted or welded together in such a manner that the ends of the hoops protrude at right angles to keep them the proper distance from the mold. The vertical reinforcement is often made of angles with holes punched at intervals for staples to fasten them to the hoops.

TABLE XXVIII.—HOOPED COLUMNS, CUMMINGS SYSTEM.
(Factor of Safety = 4.)

Size of Column, inches.	Diameter of Hoops, inches.	Breadth and Gage of Hooping Steel.	Distance c.c. of hoops inches.	No. and Size of Verticals.	Wt. of Steel per lin. ft.	Safe load for Col., in lbs.
12	10	1" - 18	2	4 - $\frac{5}{8}$ "	7.5	99,500
14	12	1" - 16	2	4 - $\frac{3}{4}$ "	9.27	143,000
16	13	1 $\frac{1}{2}$ " - 16	3	4 - $\frac{3}{4}$ "	11.88	166,400
18	15	1 $\frac{1}{2}$ " - 14	3	4 - $\frac{3}{4}$ "	14.44	223,500
20	17	1 $\frac{1}{2}$ " - 14	3	4 - $\frac{3}{4}$ "	17.52	277,000
22	19	1 $\frac{1}{2}$ " - 14	3	4 - 1"	20.93	336,200
24	21	1 $\frac{1}{2}$ " - 12	3	6 - $\frac{3}{4}$ "	26.84	430,500
26	23	1 $\frac{1}{2}$ " - 12	3	6 - 1"	31.74	505,700
28	25	1 $\frac{1}{2}$ " - 12	3	6 - 1"	32.88	575,000
30	27	1 $\frac{1}{2}$ " - 10	3	8 - 1"	43.55	704,500
32	29	1 $\frac{1}{2}$ " - 10	3	8 - 1"	45.05	786,500
34	31	1 $\frac{1}{2}$ " - 10	3	6 - 1 $\frac{1}{4}$ "	50.15	884,200
36	33	1 $\frac{1}{2}$ " - 8	3	6 - 1 $\frac{1}{4}$ "	57.69	1,036,200
38	35	1 $\frac{1}{2}$ " - 8	3	6 - 1 $\frac{1}{4}$ "	59.45	1,136,200

American Hooped Column.—The American system of column reinforcement is illustrated by Fig. 27. The spiral is made of high carbon steel. Table LVIII, page 132, compiled from Considère's formula, gives the ultimate loads for this form of column reinforcement. The manufacturers are the American Wire Fence Co., Chicago.

Monolith Hooped Column.—The monolith column reinforcement, Fig. 28, is of band steel, the vertical reinforcement being monolith bars. The manufacturers of this reinforcement, the Monolith Steel Co., Washington, D. C., advocate flat hooping for columns, as it presents greater surface to bond with the concrete, and admits of greater cross section of concrete inside the spirals, the net measurement of

which is taken for resistance to compression. For a column whose net diameter is 10 ins., there are six 8/10-in. monolith bars vertically, the hooping being $\frac{3}{4} \times \frac{1}{8}$ ins., pitched to 2 irs.

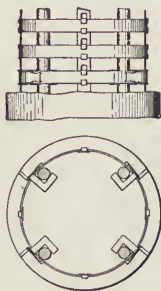

Fig. 26.—Cummings Hooped Column.

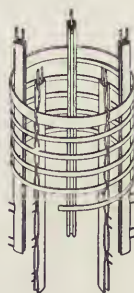

Fig. 28.—Monolith Hooped Column.

Smith Hooped Column.—Fig. 29 shows an assembled view and Fig. 30 a detail of a hooped reinforcement for concrete columns made by the F. P. Smith Wire & Iron Works, Chicago, Ill., and used for some 4,000 columns in the large

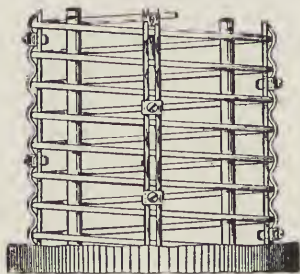

Fig. 27.—American Hooped Column.

new warehouse of reinforced concrete built for Montgomery Ward & Co., at Chicago, Ill. The reinforcement, as shown, is made up in units of any length and diameter and of any shape bar and size of hooping specified. Ordinarily the bars used are plain flats with rounded edges, as shown, and four bars are used. The bars are fixed to rotating heads and the hooping wire wound into the rounded holes, which are then closed by a hammer blow on the projecting fin or point. The pitch of the hooping can be made as desired.

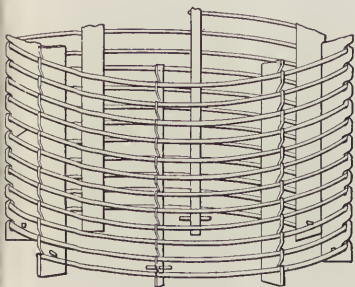

Fig. 29.—Smith Hooped Column.

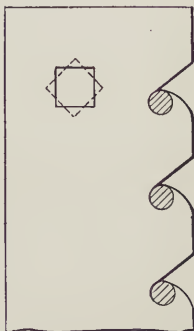

Fig. 30.—Connection of Hoops to Verticals, Smith Column.

Structural Steel.—The following tables include those forms of structural steel which may be used for reinforcing purposes. Standard Carnegie I-beams and channels are given by Tables XXIX and XXX. These are often used in beams and columns, which are afterward encased in concrete. Tables XXXI to XXXIV show corresponding data for angles. Table XXXV is inserted as being useful in determining the areas and numbers of steel rods required for a given percentage of reinforcement.

The properties of sections are given in Table XXXVI.

TABLE XXIX.—PROPERTIES OF STANDARD CARNEGIE I-BEAMS.

1	2	3	4	5	6	7	8	9
Section Index.	Depth of Beam in ins.	Weight per ft. in lbs.	Area of Section in sq. ins.	Thickness of Web in ins.	Width of Flange in ins.	Moment of Inertia, Neutral Axis Perpendicular to web at Center. I	Moment of Inertia, Neutral Axis Coincident with Center line of web. I'	Radius of Gyration, Neutral Axis Perpendicular to web at Center. r
B5	15	60.00	17.67	0.590	6.000	609.0	25.96	5.87
B7	15	42.00	12.48	0.410	5.500	441.7	14.62	5.95
B8	12	40.00	11.84	0.460	5.250	268.9	13.81	4.77
B9	12	31.50	9.26	0.350	5.000	215.8	9.50	4.83
B11	10	25.00	7.37	0.310	4.660	122.1	6.89	4.07
B13	9	21.00	6.31	0.290	4.330	84.9	5.16	3.67
B15	8	18.00	5.33	0.270	4.000	56.9	3.78	3.27
B17	7	15.00	4.42	0.250	3.660	36.2	2.67	2.36
B19	6	12.25	3.61	0.230	3.330	21.8	1.85	2.46
B21	5	9.75	2.87	0.210	3.000	12.1	1.23	2.05
B23	4	7.50	2.21	0.190	2.660	6.0	0.77	1.64
B77	3	5.50	1.63	0.170	2.330	2.5	0.46	1.23

TABLE XXX.—PROPERTIES OF STANDARD CARNEGIE CHANNELS.

1	2	3	4	5	6	7	8	9
Section Index.	Depth of Channel in ins.	Weight per ft. in lbs.	Area of Section in sq. ins.	Thickness of Web in ins.	Width of Flange in ins.	Moment of Inertia, Neutral Axis Perpendicular to web at Center. I	Moment of Inertia, Neutral Axis Parallel with Center line of web. I'	Radius of Gyration, Neutral Axis Perpendicular to web at Center. r
C1	15	33.00	9.90	0.400	3.400	312.6	8.23	5.62
C2	12	20.50	6.03	0.280	2.940	128.1	3.91	4.61
C3	10	15.00	4.46	0.240	2.600	66.9	2.30	3.87
C4	9	13.25	3.89	0.230	2.430	47.3	1.77	3.49
C5	8	11.25	3.35	0.220	2.260	32.3	1.33	3.11
C6	7	9.75	2.85	0.210	2.090	21.1	0.98	2.72
C7	6	8.00	2.38	0.200	1.920	13.0	0.70	2.34
C8	5	6.50	1.95	0.190	1.750	7.40	0.48	1.95
C9	4	5.25	1.55	0.180	1.580	3.80	0.32	1.56
C72	3	4.00	1.19	0.170	1.410	1.60	0.20	1.17

For each of the above tables:

L = Safe load in pounds uniformly distributed; l = span in feet.

M = Moment of forces in foot pounds; C and C' = coefficients given on opposite page.

TABLE XXIX. (Continued).—PROPERTIES OF STANDARD CARNEGIE I-BEAMS.

10	11	12	13	14	15
Radius of Gyration, Neutral Axis Coincident with Center line of web.	Section Modulus, Neutral Axis Perpendicular to web at Center.	Coefficient of Strength, for Fibre Stress of 16,000 lbs. per sq. in. used for Buildings.	Coefficient of Strength, for Fibre Stress of 12,500 lbs. per sq. in. used for Bridges.	Distance Center to Center of I-Beams Required to make Radii of Gyration equal	Section Index.
<i>r</i>	<i>S</i>	<i>C</i>	<i>C'</i>		
1.21	81.2	866100	876600	11.49	B5
1.08	58.9	628300	490800	11.70	B7
1.08	44.8	478100	373500	9.29	B8
1.01	36.0	383700	299700	9.45	B9
0.97	24.4	260500	203500	7.91	B11
0.90	18.9	201300	157300	7.12	B13
0.84	14.2	151700	118500	6.32	B15
0.78	10.4	110400	86300	5.50	B17
0.72	7.3	77500	60500	4.70	B19
0.65	4.8	51600	40300	B21
0.59	3.0	31800	24900	B23
0.53	1.7	17600	13800	B77

TABLE XXX. (Continued).—PROPERTIES OF STANDARD CARNEGIE CHANNELS.

10	11	12	13	14	15	16
Radius of Gyration, Neutral Axis Parallel, with Center line of web.	Section Modulus, Neutral Axis Perpendicular to web at Center.	Coefficient of Strength for Fibre Stress of 16,000 lbs. per sq. in. used for Buildings.	Coefficient of Strength, for Fibre Stress of 12,500 lbs. per sq. in. used for Bridges.	Distance Between Channels Required to make Radii of Gyration equal	Distance of Center of Gravity from Outside of web.	Section Index.
<i>r</i>	<i>S</i>	<i>C</i>	<i>C'</i>		<i>X</i>	
.912	41.7	444500	347300	9.50	0.794	C1
.805	21.4	227800	178000	7.67	0.704	C2
.718	13.4	142700	111500	6.33	0.639	C3
.674	10.5	112200	87600	5.63	0.607	C4
.630	8.1	86100	67300	4.94	0.576	C5
.586	6.0	66800	52200	4.22	0.546	C6
.542	4.3	46200	36100	3.52	0.517	C7
.498	3.0	31600	24700	2.79	0.489	C8
.453	1.9	20200	15800	2.06	0.464	C9
.409	1.1	11600	9100	1.31	0.443	C72

For each of the above tables:

$$L = \frac{C \text{ or } C'}{l}; M' = \frac{C \text{ or } C'}{8}; C \text{ or } C' = Ll = 8M' = \frac{8fS}{12}$$

REINFORCED CONCRETE.

TABLE XXXI.—PROPERTIES OF STANDARD CARNEGIE ANGLES.
Angles with unequal legs.

Section Index.	Size in Inches.	Thickness in Inches.	Weight per Foot in Pounds	Area of Section in Square Inches.	Perpendicular Distance from Center of Gravity to Back of Flange.	
					To Back of Longer Flange.	To Back of Shorter Flange.
A 89	6 x 4	1	39.6	9.00	1.17	2.17
A 91	6 x 4	$\frac{15}{16}$	28.9	8.50	1.14	2.14
A160	6 x 4	$\frac{13}{16}$	27.2	7.99	1.12	2.12
A161	6 x 4	$\frac{13}{16}$	25.4	7.47	1.10	2.10
A162	6 x 4	$\frac{13}{16}$	23.6	6.94	1.08	2.08
A163	6 x 4	$\frac{11}{16}$	21.8	6.41	1.06	2.06
A164	6 x 4	$\frac{11}{16}$	20.0	5.86	1.03	2.03
A1C5	6 x 4	$\frac{9}{16}$	18.1	5.31	1.01	2.01
A1C6	6 x 4	$\frac{7}{16}$	16.2	4.75	0.99	1.99
A1C7	6 x 4	$\frac{7}{16}$	14.3	4.18	0.96	1.96
A1C8	6 x 4	$\frac{8}{16}$	12.3	3.61	0.94	1.94
A 92	6 x $3\frac{1}{2}$	1	28.9	8.50	1.01	2.26
A 93	6 x $3\frac{1}{2}$	$\frac{15}{16}$	27.3	8.03	0.99	2.24
A1C9	6 x $3\frac{1}{2}$	$\frac{13}{16}$	25.7	7.55	0.97	2.22
A170	6 x $3\frac{1}{2}$	$\frac{13}{16}$	24.0	7.06	0.95	2.20
A171	6 x $3\frac{1}{2}$	$\frac{13}{16}$	22.4	6.56	0.93	2.18
A172	6 x $3\frac{1}{2}$	$\frac{11}{16}$	20.6	6.06	0.90	2.15
A173	6 x $3\frac{1}{2}$	$\frac{11}{16}$	18.9	5.55	0.88	2.13
A174	6 x $3\frac{1}{2}$	$\frac{9}{16}$	17.1	5.03	0.86	2.11
A175	6 x $3\frac{1}{2}$	$\frac{9}{16}$	15.3	4.50	0.83	2.08
A176	6 x $3\frac{1}{2}$	$\frac{7}{16}$	13.5	3.97	0.81	2.06
A177	6 x $3\frac{1}{2}$	$\frac{7}{16}$	11.7	3.42	0.79	2.04
A187	5 x $3\frac{1}{2}$	$\frac{7}{16}$	22.7	6.67	1.04	1.79
A188	5 x $3\frac{1}{2}$	$\frac{11}{16}$	21.3	6.25	1.02	1.77
A189	5 x $3\frac{1}{2}$	$\frac{11}{16}$	19.8	5.81	1.00	1.75
A190	5 x $3\frac{1}{2}$	$\frac{11}{16}$	18.3	5.37	0.97	1.72
A191	5 x $3\frac{1}{2}$	$\frac{9}{16}$	16.8	4.92	0.95	1.70
A192	5 x $3\frac{1}{2}$	$\frac{9}{16}$	15.2	4.47	0.93	1.68
A193	5 x $3\frac{1}{2}$	$\frac{7}{16}$	13.6	4.00	0.91	1.66
A194	5 x $3\frac{1}{2}$	$\frac{7}{16}$	12.0	3.53	0.88	1.63
A195	5 x $3\frac{1}{2}$	$\frac{5}{16}$	10.4	3.05	0.86	1.61
A 96	5 x $3\frac{1}{2}$	$\frac{5}{16}$	8.7	2.56	0.84	1.59
A196	5 x 3	$\frac{13}{16}$	19.9	5.84	0.86	1.86
A197	5 x 3	$\frac{13}{16}$	18.5	5.44	0.84	1.84
A198	5 x 3	$\frac{11}{16}$	17.1	5.03	0.82	1.82
A199	5 x 3	$\frac{11}{16}$	15.7	4.61	0.80	1.80
A200	5 x 3	$\frac{9}{16}$	14.3	4.18	0.77	1.77
A201	5 x 3	$\frac{9}{16}$	12.8	3.75	0.75	1.75
A202	5 x 3	$\frac{7}{16}$	11.3	3.31	0.73	1.73
A203	5 x 3	$\frac{7}{16}$	9.8	2.86	0.70	1.70
A280	5 x 3	$\frac{5}{16}$	8.2	2.40	0.68	1.68

TABLE XXXI. (Continued).—PROPERTIES OF STANDARD CARNEGIE ANGLES.
Angles with unequal legs.

8	9	10	11	12	13	14	15
Moment of Inertia. I		Section Modulus. S		Radii of Gyration. r			Section Index
Neutral Axis Parallel to Longer Flange.	Neutral Axis Parallel to Shorter Flange.	Neutral Axis Parallel to Longer Flange.	Neutral Axis Parallel to Shorter Flange.	Neutral Axis Parallel to Longer Flange.	Neutral Axis Parallel to Shorter Flange.	Least Radius.	
10.75	30.75	3.79	8.02	1.09	1.85	0.85	A 89
10.26	29.26	3.59	7.59	1.10	1.86	0.85	A 91
9.75	27.73	3.39	7.15	1.11	1.86	0.86	A 160
9.23	26.15	3.18	6.70	1.11	1.87	0.86	A 161
8.68	24.51	2.97	6.25	1.12	1.88	0.86	A 162
8.11	22.82	2.76	5.78	1.13	1.89	0.86	A 163
7.52	21.07	2.54	5.31	1.13	1.90	0.86	A 164
6.91	19.26	2.31	4.83	1.14	1.90	0.87	A 165
6.27	17.40	2.08	4.33	1.15	1.91	0.87	A 166
5.60	15.46	1.85	3.83	1.16	1.92	0.87	A 167
4.90	13.47	1.60	3.32	1.17	1.93	0.88	A 168
7.21	29.24	2.90	7.83	0.92	1.85	0.74	A 92
6.88	27.84	2.74	7.41	0.93	1.86	0.74	A 93
6.55	26.38	2.59	6.98	0.93	1.87	0.75	A 169
6.20	24.89	2.43	6.55	0.94	1.88	0.75	A 170
5.84	23.34	2.27	6.10	0.94	1.89	0.75	A 171
5.47	21.74	2.11	5.65	0.95	1.89	0.75	A 172
5.08	20.08	1.94	5.19	0.96	1.90	0.75	A 173
4.67	18.37	1.77	4.72	0.96	1.91	0.75	A 174
4.25	16.59	1.59	4.24	0.97	1.92	0.76	A 175
3.81	14.76	1.41	3.75	0.98	1.93	0.76	A 176
3.34	12.86	1.23	3.25	0.99	1.94	0.77	A 177
6.21	15.67	2.52	4.88	0.96	1.53	0.75	A 187
5.89	14.81	2.37	4.58	0.97	1.54	0.75	A 188
5.55	13.92	2.22	4.28	0.98	1.55	0.75	A 189
5.20	12.99	2.06	3.97	0.98	1.56	0.75	A 190
4.83	12.03	1.90	3.65	0.99	1.56	0.75	A 191
4.45	11.03	1.73	3.32	1.00	1.57	0.75	A 192
4.05	9.99	1.56	2.99	1.01	1.58	0.75	A 193
3.63	8.90	1.39	2.64	1.01	1.59	0.76	A 194
3.18	7.78	1.21	2.29	1.02	1.60	0.76	A 195
2.72	6.60	1.02	1.94	1.03	1.61	0.76	A 96
3.71	13.98	1.74	4.45	0.83	1.55	0.64	A 196
3.51	13.15	1.63	4.16	0.83	1.55	0.64	A 197
3.29	12.28	1.51	3.86	0.81	1.56	0.64	A 198
3.06	11.37	1.39	3.55	0.82	1.57	0.64	A 199
2.83	10.43	1.27	3.23	0.82	1.58	0.65	A 200
2.58	9.45	1.15	2.91	0.83	1.59	0.65	A 201
2.32	8.43	1.02	2.58	0.84	1.60	0.65	A 202
2.04	7.37	0.89	2.24	0.84	1.61	0.65	A 203
1.75	6.26	0.75	1.89	0.85	1.61	0.66	A 280

REINFORCED CONCRETE.

TABLE XXXII.—PROPERTIES OF STANDARD CARNEGIE ANGLES.
Angles with unequal legs.

Section Index.	Size in Inches.	Thickness in Inches.	Weight per Foot in Pounds.	Area of Section in Square Inches.	Perpendicular Distance from Center of Gravity to Back of Flange.	
					To Back of Longer Flange.	To Back of Shorter Flange.
A220	4 x 3	$\frac{1}{16}$	17.1	5.03	0.94	1.44
A221	4 x 3	$\frac{3}{16}$	16.0	4.69	0.92	1.42
A222	4 x 3	$\frac{1}{8}$	14.8	4.34	0.89	1.39
A223	4 x 3	$\frac{3}{16}$	13.6	3.98	0.87	1.37
A224	4 x 3	$\frac{1}{4}$	12.4	3.62	0.85	1.35
A225	4 x 3	$\frac{5}{16}$	11.1	3.25	0.83	1.33
A226	4 x 3	$\frac{3}{8}$	9.8	2.87	0.80	1.30
A227	4 x 3	$\frac{7}{16}$	8.5	2.48	0.78	1.28
A228	4 x 3	$\frac{1}{2}$	7.2	2.09	0.76	1.26
A229	$3\frac{1}{2}$ x 3	$\frac{1}{16}$	15.8	4.62	0.98	1.23
A230	$3\frac{1}{2}$ x 3	$\frac{3}{16}$	14.7	4.31	0.96	1.21
A231	$3\frac{1}{2}$ x 3	$\frac{1}{8}$	13.6	4.00	0.94	1.19
A232	$3\frac{1}{2}$ x 3	$\frac{3}{16}$	12.5	3.67	0.92	1.17
A233	$3\frac{1}{2}$ x 3	$\frac{1}{4}$	11.4	3.34	0.90	1.15
A234	$3\frac{1}{2}$ x 3	$\frac{5}{16}$	10.2	3.03	0.88	1.13
A235	$3\frac{1}{2}$ x 3	$\frac{3}{8}$	9.1	2.65	0.85	1.10
A236	$3\frac{1}{2}$ x 3	$\frac{7}{16}$	7.9	2.30	0.83	1.08
A237	$3\frac{1}{2}$ x 3	$\frac{1}{2}$	6.6	1.93	0.81	1.06
A238	$3\frac{1}{2}$ x $2\frac{1}{2}$	$\frac{1}{16}$	12.5	3.65	0.77	1.27
A239	$3\frac{1}{2}$ x $2\frac{1}{2}$	$\frac{3}{16}$	11.5	3.36	0.75	1.25
A240	$3\frac{1}{2}$ x $2\frac{1}{2}$	$\frac{1}{8}$	10.4	3.05	0.73	1.23
A241	$3\frac{1}{2}$ x $2\frac{1}{2}$	$\frac{3}{16}$	9.4	2.75	0.70	1.20
A242	$3\frac{1}{2}$ x $2\frac{1}{2}$	$\frac{1}{4}$	8.3	2.43	0.68	1.18
A243	$3\frac{1}{2}$ x $2\frac{1}{2}$	$\frac{5}{16}$	7.2	2.11	0.66	1.16
A244	$3\frac{1}{2}$ x $2\frac{1}{2}$	$\frac{3}{8}$	6.1	1.78	0.64	1.14
A245	$3\frac{1}{2}$ x $2\frac{1}{2}$	$\frac{7}{16}$	4.9	1.44	0.61	1.11
A252	3 x $2\frac{1}{2}$	$\frac{9}{16}$	9.5	2.78	0.77	1.02
A253	3 x $2\frac{1}{2}$	$\frac{5}{8}$	8.5	2.50	0.75	1.00
A254	3 x $2\frac{1}{2}$	$\frac{7}{16}$	7.6	2.22	0.73	0.98
A255	3 x $2\frac{1}{2}$	$\frac{1}{2}$	6.6	1.92	0.71	0.96
A256	3 x $2\frac{1}{2}$	$\frac{9}{16}$	5.6	1.62	0.68	0.93
A257	3 x $2\frac{1}{2}$	$\frac{5}{8}$	4.5	1.31	0.66	0.91
A264	$2\frac{1}{2}$ x 2	$\frac{1}{2}$	6.8	2.07	0.63	0.88
A265	$2\frac{1}{2}$ x 2	$\frac{3}{8}$	6.1	1.78	0.60	0.85
A266	$2\frac{1}{2}$ x 2	$\frac{1}{4}$	5.3	1.55	0.58	0.83
A267	$2\frac{1}{2}$ x 2	$\frac{3}{8}$	4.5	1.31	0.56	0.81
A268	$2\frac{1}{2}$ x 2	$\frac{1}{2}$	3.7	1.06	0.54	0.79
A269	$2\frac{1}{2}$ x 2	$\frac{3}{8}$	2.8	0.81	0.51	0.76

TABLE XXXII. (Continued).—PROPERTIES OF STANDARD CARNEGIE ANGLES.
Angles with unequal legs.

8	9	10	11	12	13	14	15
Moment of Inertia. I		Section Modulus. S		Radii of Gyration. r			Section Index
Neutral Axis Parallel to Longer Flange.	Neutral Axis Parallel to Shorter Flange.	Neutral Axis Parallel to Longer Flange.	Neutral Axis Parallel to Shorter Flange.	Neutral Axis Parallel to Longer Flange.	Neutral Axis Parallel to Shorter Flange.	Least Radius.	
3.47	7.21	1.68	2.87	0.83	1.21	0.64	A220
3.28	6.93	1.57	2.68	0.84	1.22	0.64	A221
3.08	6.49	1.46	2.49	0.84	1.22	0.64	A222
2.87	6.03	1.35	2.30	0.85	1.23	0.64	A223
2.66	5.55	1.23	2.09	0.86	1.24	0.64	A224
2.42	5.02	1.12	1.89	0.86	1.25	0.64	A225
2.18	4.52	0.99	1.68	0.87	1.25	0.64	A226
1.92	3.96	0.87	1.46	1.88	1.26	0.64	A227
1.65	3.38	0.74	1.23	0.89	1.27	0.65	A228
3.33	4.98	1.65	2.20	0.85	1.04	0.62	A229
3.15	4.70	1.54	2.05	0.85	1.04	0.62	A230
2.96	4.41	1.44	1.91	0.86	1.05	0.62	A231
2.76	4.11	1.33	1.76	0.87	1.06	0.62	A232
2.55	3.79	1.21	1.61	0.87	1.07	0.62	A233
2.33	3.45	1.10	1.45	0.88	1.07	0.62	A234
2.09	3.10	0.98	1.29	0.89	1.08	0.62	A235
1.85	2.72	0.85	1.13	0.90	1.09	0.62	A236
1.58	2.33	0.72	0.96	0.90	1.10	0.63	A237
1.72	4.13	0.99	1.85	0.67	1.06	0.53	A238
1.61	3.85	0.92	1.71	0.69	1.07	0.53	A239
1.49	3.55	0.84	1.56	0.70	1.08	0.53	A240
1.36	3.24	0.76	1.41	0.70	1.09	0.53	A241
1.23	2.91	0.68	1.26	0.71	1.09	0.54	A242
1.09	2.56	0.59	1.09	0.72	1.10	0.54	A243
0.94	2.19	0.50	0.93	0.73	1.11	0.54	A244
0.78	1.80	0.41	0.75	0.74	1.12	0.54	A245
1.42	2.28	0.82	1.15	0.72	0.91	0.52	A252
1.30	2.08	0.74	1.04	0.72	0.91	0.52	A253
1.18	1.88	0.66	0.93	0.73	0.92	0.52	A254
1.04	1.66	0.58	0.81	0.74	0.93	0.52	A255
0.90	1.42	0.49	0.69	0.74	0.94	0.53	A256
0.74	1.17	0.40	0.56	0.75	0.95	0.53	A257
0.64	1.14	0.46	0.70	0.56	0.75	0.42	A264
0.58	1.03	0.41	0.62	0.57	0.76	0.42	A265
0.51	0.91	0.36	0.55	0.58	0.77	0.42	A266
0.45	0.79	0.31	0.47	0.58	0.78	0.42	A267
0.37	0.65	0.25	0.38	0.59	0.78	0.42	A268
0.29	0.51	0.20	0.29	0.60	0.79	0.43	A269

REINFORCED CONCRETE.

TABLE XXXIII.—PROPERTIES OF STANDARD CARNEGIE ANGLES.
Angles with equal legs.

1	2	3	4	5	6	7	8	9	10
Section Index.	Size in Inches.	Thickness in Inches.	Weight per Foot in Pounds.	Area of Section, in Square Inches.	Distance of Center of Gravity from Back of Flange, in Inches.	Moment of Inertia, Neutral Axis through Center of Gravity Parallel to Flange.	Section Modulus, Neutral Axis as before.	Radius of Gyration, Neutral Axis as before.	Least Radius of Gyration, Neutral Axis through Center of Gravity at 45° to Flanges.
A113	8x8	1 1/8	56.9	16.73	2.41	97.97	17.53	2.42	1.55
A112	8x8	1 1/8	54.0	15.87	2.39	93.53	16.67	2.43	1.56
A111	8x8	1 1/8	51.0	15.00	2.37	88.98	15.80	2.44	1.56
A110	8x8	1 1/8	48.1	14.12	2.34	84.33	14.91	2.44	1.56
A109	8x8	1 1/8	45.0	13.23	2.32	79.58	14.01	2.45	1.57
A108	8x8	1 3/8	42.0	12.34	2.30	74.71	13.11	2.46	1.57
A107	8x8	1 3/8	38.9	11.44	2.28	69.74	12.18	2.47	1.57
A106	8x8	1 3/8	35.8	10.53	2.25	64.64	11.25	2.48	1.58
A105	8x8	1 3/8	32.7	9.61	2.23	59.42	10.30	2.49	1.58
A104	8x8	1 3/8	29.6	8.68	2.21	54.09	9.34	2.50	1.58
A103	8x8	1 3/8	26.4	7.75	2.19	48.63	8.37	2.50	1.58
A86	6x6	1	37.4	11.00	1.86	35.46	8.57	1.89	1.16
A87	6x6	1	35.3	10.37	1.84	33.72	8.11	1.89	1.16
A1	6x6	1	33.1	9.74	1.82	31.92	7.64	1.81	1.17
A2	6x6	1	31.0	9.09	1.80	30.06	7.15	1.82	1.17
A3	6x6	1	28.7	8.44	1.78	28.15	6.66	1.83	1.17
A4	6x6	1 1/8	26.5	7.78	1.75	26.19	6.17	1.83	1.17
A5	6x6	1 1/8	24.2	7.11	1.73	24.16	5.66	1.84	1.18
A6	6x6	1 1/8	21.9	6.43	1.71	22.07	5.14	1.85	1.18
A7	6x6	1 1/8	19.6	5.75	1.68	19.91	4.61	1.86	1.18
A8	6x6	1 1/8	17.2	5.06	1.66	17.68	4.07	1.87	1.19
A88	6x6	1 1/8	14.9	4.36	1.64	15.39	3.53	1.88	1.19
A18	4x4	1 3/8	19.9	5.84	1.29	8.14	3.01	1.18	0.77
A19	4x4	1 3/8	18.5	5.44	1.27	7.67	2.81	1.19	0.77
A20	4x4	1 3/8	17.1	5.03	1.25	7.17	2.61	1.19	0.77
A21	4x4	1 3/8	15.7	4.61	1.23	6.66	2.40	1.20	0.77
A22	4x4	1 3/8	14.3	4.18	1.21	6.12	2.19	1.21	0.78
A23	4x4	1 3/8	12.8	3.75	1.18	5.56	1.97	1.22	0.78
A24	4x4	1 3/8	11.3	3.31	1.16	4.97	1.75	1.23	0.78
A25	4x4	1 3/8	9.8	2.86	1.14	4.36	1.52	1.23	0.79
A90	4x4	1 3/8	8.2	2.40	1.12	3.71	1.29	1.24	0.79
A26	3 1/2 x 3 1/2	1 3/8	17.1	5.03	1.17	5.25	2.25	1.02	0.67
A27	3 1/2 x 3 1/2	1 3/8	16.0	4.69	1.15	4.96	2.11	1.03	0.67
A28	3 1/2 x 3 1/2	1 3/8	14.8	4.34	1.12	4.65	1.96	1.04	0.67
A29	3 1/2 x 3 1/2	1 3/8	13.6	3.98	1.10	4.33	1.81	1.04	0.67
A30	3 1/2 x 3 1/2	1 3/8	12.4	3.62	1.08	3.99	1.65	1.05	0.68
A31	3 1/2 x 3 1/2	1 3/8	11.1	3.25	1.06	3.64	1.49	1.06	0.68
A32	3 1/2 x 3 1/2	1 3/8	9.8	2.87	1.04	3.26	1.32	1.07	0.68
A33	3 1/2 x 3 1/2	1 3/8	8.5	2.48	1.01	2.87	1.15	1.07	0.69
A99	3 1/2 x 3 1/2	1 3/8	7.2	2.09	0.99	2.45	0.98	1.08	0.69

TABLE XXXIV.—PROPERTIES OF STANDARD CARNEGIE ANGLES.
Angles with equal legs.

1	2	3	4	5	6	7	8	9	10
Section Index.	Size in Inches.	Thickness in Inches.	Weight per Foot in Pounds.	Area of Section, in Square Inches.	Distance of Center of Gravity from Back of Flange, in Inches.	Moment of Inertia, Neutral Axis through Center of Gravity Parallel to Flange.	Section Modulus, Neutral Axis as before.	Radius of Gyration, Neutral Axis as before.	Least Radius of Gyration, Neutral Axis through Center of Gravity at 45° to Flanges.
A34	3x3	$\frac{1}{4}$	11.5	3.36	0.98	2.62	1.30	0.88	0.57
A35	3x3	$\frac{3}{8}$	10.4	3.06	0.95	2.43	1.19	0.89	0.58
A36	3x3	$\frac{1}{2}$	9.4	2.75	0.93	2.22	1.07	0.90	0.58
A37	3x3	$\frac{5}{8}$	8.3	2.43	0.91	1.99	0.95	0.91	0.58
A38	3x3	$\frac{3}{4}$	7.2	2.11	0.89	1.76	0.83	0.91	0.58
A39	3x3	$\frac{7}{8}$	6.1	1.78	0.87	1.51	0.71	0.92	0.59
A40	3x3	1	4.9	1.44	0.84	1.24	0.58	0.93	0.59
A46	2½x2½	$\frac{1}{4}$	7.7	2.25	0.81	1.23	0.73	0.74	0.47
A47	2½x2½	$\frac{3}{8}$	6.8	2.00	0.78	1.11	0.65	0.74	0.48
A48	2½x2½	$\frac{1}{2}$	5.9	1.73	0.76	0.98	0.57	0.75	0.48
A49	2½x2½	$\frac{5}{8}$	5.0	1.47	0.74	0.85	0.48	0.76	0.49
A50	2½x2½	$\frac{3}{4}$	4.1	1.19	0.72	0.70	0.40	0.77	0.49
A100	2½x2½	$\frac{7}{8}$	3.1	0.90	0.69	0.55	0.30	0.78	0.49
A56	2x2	$\frac{1}{4}$	5.3	1.56	0.66	0.54	0.40	0.59	0.39
A57	2x2	$\frac{3}{8}$	4.7	1.36	0.64	0.48	0.35	0.59	0.39
A58	2x2	$\frac{1}{2}$	4.0	1.15	0.61	0.42	0.30	0.60	0.39
A59	2x2	$\frac{5}{8}$	3.2	0.94	0.59	0.35	0.25	0.61	0.39
A60	2x2	$\frac{3}{4}$	2.5	0.72	0.57	0.28	0.19	0.62	0.40
A61	1½x1½	$\frac{1}{4}$	4.6	1.30	0.59	0.35	0.30	0.51	0.33
A62	1½x1½	$\frac{3}{8}$	4.0	1.17	0.57	0.31	0.26	0.51	0.34
A63	1½x1½	$\frac{1}{2}$	3.4	1.00	0.55	0.27	0.23	0.52	0.34
A64	1½x1½	$\frac{5}{8}$	2.8	0.81	0.53	0.23	0.19	0.53	0.34
A65	1½x1½	$\frac{3}{4}$	2.2	0.62	0.51	0.18	0.14	0.54	0.35
A66	1½x1½	$\frac{7}{8}$	3.4	0.99	0.51	0.19	0.19	0.44	0.29
A67	1½x1½	1	2.9	0.84	0.49	0.16	0.162	0.44	0.29
A68	1½x1½	$\frac{1}{4}$	2.4	0.69	0.47	0.14	0.134	0.45	0.29
A69	1½x1½	$\frac{3}{8}$	1.8	0.53	0.44	0.11	0.124	0.46	0.29
A102	1½x1½	$\frac{1}{2}$	1.3	0.36	0.42	0.08	0.070	0.46	0.30
A70	1½x1½	$\frac{5}{8}$	2.4	0.69	0.42	0.09	0.109	0.36	0.23
A71	1½x1½	$\frac{3}{4}$	2.0	0.56	0.40	0.077	0.091	0.37	0.24
A72	1½x1½	$\frac{7}{8}$	1.5	0.43	0.38	0.061	0.071	0.38	0.24
A73	1½x1½	1	1.1	0.30	0.35	0.044	0.049	0.38	0.25
A78	1x1	$\frac{1}{4}$	1.5	0.44	0.34	0.037	0.056	0.29	0.19
A79	1x1	$\frac{3}{8}$	1.2	0.34	0.32	0.030	0.044	0.30	0.19
A80	1x1	$\frac{1}{2}$	0.8	0.24	0.30	0.022	0.031	0.31	0.20
A83	2x2	$\frac{1}{4}$	0.9	0.25	0.23	0.012	0.024	0.22	0.16
A84	2x2	$\frac{3}{8}$	0.6	0.17	0.23	0.009	0.017	0.23	0.17

TABLE XXXV.—AREA AND CIRCUMFERENCE OF CIRCLES.

Diameter.			Area.		Circumference	
Decimals of a foot.	Ins. and fract'ns	Ins and decimals.	Decimals of a sq. ft.	Sq. ins. decimals.	Decimals of a foot.	Ins. and decimals.
.00260	$\frac{1}{32}$.03125	.000005	.00077	.0082	.09818
.00521	$\frac{1}{16}$.0625	.000021	.00307	.0164	.19635
.00781	$\frac{3}{32}$.09375	.000048	.00690	.0245	.29452
.01042	$\frac{1}{8}$.125	.000085	.01227	.0327	.39270
.01302	$\frac{5}{32}$.15625	.000133	.01917	.0409	.49087
.01562	$\frac{3}{16}$.1875	.000192	.02761	.0491	.58905
.01823	$\frac{7}{32}$.21875	.000261	.03758	.0573	.68722
.02083	$\frac{1}{4}$.25	.000341	.04909	.0654	.78540
.02344	$\frac{9}{32}$.28125	.000431	.06213	.0736	.88357
.02604	$\frac{5}{16}$.3125	.000533	.07670	.0818	.98175
.02865	$\frac{11}{32}$.34375	.000644	.09281	.0900	1.0799
.03125	$\frac{3}{8}$.375	.000767	.11045	.0982	1.1781
.03385	$\frac{13}{32}$.40625	.000900	.12962	.1064	1.2763
.03646	$\frac{7}{16}$.4375	.001044	.15033	.1145	1.3744
.03906	$\frac{15}{32}$.46875	.001198	.17257	.1227	1.4726
.04167	$\frac{1}{2}$.50	.001363	.19635	.1309	1.5708
.04427	$\frac{17}{32}$.53125	.001539	.22166	.1391	1.6690
.04688	$\frac{9}{16}$.5625	.001726	.24859	.1473	1.7671
.04948	$\frac{19}{32}$.59375	.001923	.27688	.1554	1.8653
.05208	$\frac{5}{8}$.625	.002130	.30680	.1636	1.9635
.05469	$\frac{21}{32}$.65625	.002349	.33824	.1718	2.0617
.05729	$\frac{11}{16}$.6875	.002578	.37122	.1800	2.1598
.05990	$\frac{23}{32}$.71875	.002817	.40574	.1882	2.2580
.06250	$\frac{3}{4}$.75	.003068	.44179	.1963	2.3562
.06510	$\frac{25}{32}$.78125	.003329	.47937	.2045	2.4544
.06771	$\frac{13}{16}$.8125	.003604	.51849	.2127	2.5525
.07031	$\frac{27}{32}$.84375	.003883	.55914	.2209	2.6507
.07292	$\frac{7}{8}$.875	.004176	.60132	.2291	2.7489
.07552	$\frac{29}{32}$.90625	.004479	.64504	.2373	2.8471
.07813	$\frac{15}{8}$.9375	.004793	.69029	.2454	2.9452
.08073	$\frac{31}{32}$.96875	.005118	.73708	.2536	3.0434
.0833	1	1.0000	.005454	.7854	.2618	3.1416
.0859	$\frac{1}{32}$	1.03125	.005800	.8353	.2700	3.2398
.0885	$\frac{3}{32}$	1.0625	.006157	.8866	.2782	3.3379
.0911	$\frac{5}{32}$	1.09375	.006524	.9396	.2863	3.4361
.0938	$\frac{7}{32}$	1.125	.006902	.9940	.2945	3.5343
.0964	$\frac{9}{32}$	1.15625	.007291	1.0500	.3027	3.6325
.0990	$\frac{11}{32}$	1.1875	.007691	1.1075	.3109	3.7306
.1016	$\frac{13}{32}$	1.21875	.008101	1.1666	.3191	3.8288
.1042	$\frac{15}{32}$	1.25	.008522	1.2272	.3272	3.9270
.1068	$\frac{17}{32}$	1.28125	.008953	1.2893	.3354	4.0252
.1094	$\frac{19}{32}$	1.3125	.009395	1.3530	.3436	4.1233
.1120	$\frac{21}{32}$	1.34375	.009848	1.4182	.3518	4.2215
.1146	$\frac{23}{32}$	1.375	.010311	1.4849	.3600	4.3197
.1172	$\frac{25}{32}$	1.40625	.010785	1.5532	.3682	4.4179
.1198	$\frac{27}{32}$	1.4375	.011270	1.6230	.3763	4.5160
.1224	$\frac{29}{32}$	1.46875	.011767	1.6943	.3845	4.6142

TABLE XXXV. (Continued).—AREA AND CIRCUMFERENCE OF CIRCLES.

Diameter.			Area.		Circumference	
Decimals of a foot.	Ins. and fract'ns	In. and decimals.	Decimals of a sq. ft.	Sq. ins. decimals.	Decimals of a foot.	Ins. and decimals.
.1250	1 $\frac{1}{8}$	1.50	.01227	1.7671	.3927	4.7124
.1276	$\frac{1}{8}$	1.53125	.01279	1.8415	.4009	4.8106
.1302	$\frac{1}{8}$	1.5625	.01331	1.9175	.4091	4.9087
.1328	$\frac{1}{8}$	1.59375	.01385	1.9949	.4172	5.0069
.1354	$\frac{1}{8}$	1.625	.01440	2.0739	.4254	5.1051
.1380	$\frac{1}{8}$	1.65625	.01496	2.1545	.4336	5.2033
.1406	$\frac{1}{8}$	1.6875	.01553	2.2365	.4418	5.3014
.1432	$\frac{1}{8}$	1.71875	.01611	2.3201	.4500	5.3996
.1458	$\frac{3}{16}$	1.75	.01670	2.4053	.4581	5.4978
.1484	$\frac{3}{16}$	1.78125	.01730	2.4920	.4663	5.5960
.1510	$\frac{3}{16}$	1.8125	.01792	2.5802	.4745	5.6941
.1536	$\frac{3}{16}$	1.84375	.01854	2.6699	.4827	5.7923
.1563	$\frac{3}{16}$	1.875	.01917	2.7612	.4909	5.8905
.1589	$\frac{3}{16}$	1.90625	.01982	2.8540	.4991	5.9887
.1615	$\frac{3}{16}$	1.9375	.02047	2.9483	.5072	6.0868
.1642	$\frac{3}{16}$	1.96875	.02114	3.0442	.5154	6.1850
.1667	2	2.00	.02182	3.1416	.5236	6.2832
.1719	$\frac{1}{8}$	2.0625	.02320	3.3410	.5400	6.4795
.1771	$\frac{1}{8}$	2.125	.02463	3.5466	.5563	6.6759
.1823	$\frac{1}{8}$	2.1875	.02610	3.7583	.5727	6.8722
.1875	$\frac{1}{8}$	2.25	.02761	3.9761	.5890	7.0686
.1927	$\frac{1}{8}$	2.3125	.02917	4.2000	.6054	7.2649
.1979	$\frac{1}{8}$	2.375	.03076	4.4301	.6218	7.4613
.2031	$\frac{1}{8}$	2.4375	.03240	4.6664	.6381	7.6576
.2083	$\frac{1}{8}$	2.50	.03409	4.9087	.6545	7.8540
.2135	$\frac{1}{8}$	2.5625	.03581	5.1572	.6709	8.0503
.2187	$\frac{1}{8}$	2.625	.03758	5.4119	.6872	8.2467
.2240	$\frac{1}{8}$	2.6875	.03939	5.6727	.7036	8.4430
.2292	$\frac{1}{8}$	2.75	.04124	5.9396	.7199	8.6394
.2344	$\frac{1}{8}$	2.8125	.04314	6.2126	.7363	8.8357
.2396	$\frac{1}{8}$	2.875	.04508	6.4918	.7527	9.0321
.2448	$\frac{1}{8}$	2.9375	.04706	6.7771	.7690	9.2284
.2500	3	3.00	.04908	7.0686	.7854	9.4248
.2552	$\frac{1}{8}$	3.0625	.05115	7.3662	.8018	9.6211
.2604	$\frac{1}{8}$	3.125	.05326	7.6699	.8181	9.8175
.2656	$\frac{1}{8}$	3.1875	.05541	7.9798	.8345	10.014
.2708	$\frac{1}{8}$	3.25	.05761	8.2958	.8508	10.210
.2760	$\frac{1}{8}$	3.3125	.05984	8.6179	.8672	10.407
.2812	$\frac{1}{8}$	3.375	.06212	8.9462	.8836	10.603
.2865	$\frac{1}{8}$	3.4375	.06444	9.2806	.8999	10.799
.2917	$\frac{1}{8}$	3.50	.06681	9.6211	.9163	10.996
.2969	$\frac{1}{8}$	3.5625	.06922	9.9678	.9327	11.192
.3021	$\frac{1}{8}$	3.625	.07167	10.321	.9490	11.388
.3073	$\frac{1}{8}$	3.6875	.07416	10.680	.9654	11.585
.3125	$\frac{1}{8}$	3.75	.07669	10.045	.9817	11.781
.3177	$\frac{1}{8}$	3.8125	.07927	11.416	.9981	11.977
.3229	$\frac{1}{8}$	3.875	.08189	11.793	1.0145	12.174
.3281	$\frac{1}{8}$	3.9375	.08456	12.177	1.0308	12.370
.3333	$\frac{1}{8}$	4.00	.08726	12.566	1.0472	12.566

TABLE XXXVI.—PROPERTIES OF VARIOUS SECTIONS.

SECTION.	Moment of Inertia. I	Section Modulus $S = \frac{I}{n}$
	$\frac{bh^3}{12}$	$\frac{bh^2}{6}$
	$\frac{bh^3}{3}$	$\frac{bh^2}{3}$
	$\frac{bh^3}{36}$	$\frac{bh^2}{24}$
	$\frac{b^4}{12}$	$\frac{b^3}{6\sqrt{2}} = 0.118b^3$
	$\frac{\pi d^4}{64} = 0.0491d^4$	$\frac{\pi d^3}{32} = 0.098d^3$
	$\frac{bh^3 - b'h'^3}{12}$	$\frac{bh^3 - b'h'^3}{6h}$
	$0.049(d^4 - d'^4)$	$0.098 \left(\frac{d^4 - d'^4}{d} \right)$
	$\frac{tn^3 + bn'^3 - b'a^3}{3}$	$\frac{I}{n}$
	$\frac{th^3 + bt'^3}{12}$	$\frac{th^3 + bt'^3}{6h}$

xx is the position of neutral axis.
 n and n' are the distances from the neutral axis to most remote fibers of the section; n being the greater.

CHAPTER II.

DESIGN AND CONSTRUCTION OF BUILDINGS.

GENERAL DISCUSSION.

Reinforced concrete is used for nearly every type of building. The variety of designs employed is so great that the subject will be considered here in only a general way. In all designing it is necessary to figure on the strength attained by the concrete at the time the molds are removed. For instance, when molds must be removed in 48 hours, it is necessary to design a section that will have the requisite strength in 48 hours; where molds may remain for 28 days, early strength is not required.

General Assumptions Made in Design.—Before designing, certain assumptions must be made in order to eliminate some of the variables entering into reinforced concrete construction. The assumptions usually made in the United States to date are as follows:

(1) Sections plane before bending remain plane after bending, at least within the limit of elasticity of the steel.

(2) Stresses in sections subjected to bending are computed assuming that elongations vary with the distance from the neutral axis.

(3) The union between the steel and the concrete is sufficient to cause the two materials to act as one material, the unit value of adhesion being at least equal to the unit shear of concrete.

(4) No initial strains are considered in either the concrete or the steel due to change of volume of the concrete in setting.

(5) The concrete takes up the compression, while the steel takes up the tension and assists in the resistance to shear.

(6) The form of stress-strain curve of concrete in compression is, as a rule, assumed as a straight line.

(7) Columns are designed for flexure, if the height exceeds 18 times the least diameter.

(8) The ratio of the modulus of elasticity of steel to that of concrete, which varies with the quality and bulk of the concrete, is generally assumed to be 10.

Percentage of Steel Reinforcement.—This varies according to construction, design, proportion in mixtures and is different in girders, floor slabs and columns, as will appear as each detail is treated. As a rule, p is a function of the ratio between the moduli of elasticity, the ratio of the actual stresses in the steel and in the concrete, and of the ratio between the unit costs of steel and concrete. A writer in Engineering News, June 20, 1907, sums up, in part, as follows:

(1) When a beam is strictly limited as to depth an over-reinforced beam is the cheapest.

(2) When beams or slabs are not limited in dimensions by local conditions, the cheapest construction is that which is reinforced for the full utilization of both concrete and steel. These conditions are easily shown graphically in curves, giving the most economical percentage under different assumptions. Thus, for the city of New York, with $\frac{E_s}{E_c} = 12$, $f = 16,000$ and $C = 625$, it is found that the most economical percentage is $p = 0.0062$ or 0.62 per cent reinforcement. See page 98 for notation.

Basis of Calculations.—While the assumptions made in design are subject to considerable variation, the following paragraphs contain figures which are supported by good engineering practice and can be relied upon:

Dead Loads.—The following figures are for dead loads:

Weight of cinder concrete.....	120 lbs. per cu. ft.
Weight of stone concrete.....	140 lbs. per cu. ft.
Weight of reinforced concrete.....	4150 lbs. per cu. ft.
Weight of steel.....	789.6 lbs. per cu. ft.
Weight of wood or tile floors.....	20 lbs. per sq. ft.

Live Loads.—In the absence of uniformity in American practice regarding a general method of assuming live loads, the following is recommended, from the Prussian building code, as being safe and economical:

Structural parts subject to moderate impact, the actual dead and live loads.

Parts subject to higher impact or widely varying loads, the actual dead load and $1\frac{1}{2}$ times the live load.

Parts subject to heavy shocks, the actual dead load and twice the live load.

Allowable Stresses.—The allowable stresses in reinforced concrete must necessarily depend upon many factors. The following figures are general, and are to be supplemented by reference to Floors, Columns, etc. They refer to a mixture not leaner than 1-5.

Reinforced concrete in tension, 0 lbs. per sq. in.

Reinforced concrete in compression, 750 lbs. per sq. in.

Reinforced concrete in shear, 75 lbs. per sq. in.

Steel in tension, with factor of safety of 4, 16,000 lbs. per sq. in.

Steel in compression, 10,000 lbs. per sq. in.

Steel in shear, 10,000 lbs. per sq. in.

Bending Moments for Beams.*—The negative moments over the supports of a continuous beam on both sides of these supports produce tension in the upper portion of the beam.

Let M'_B = bending moment at support for center load.

M''_B = bending moment at support for uniformly distributed loads.

W = total load upon each beam in pounds.

w = uniformly distributed load in lbs. per foot of beam.

l = length of beam in feet.

Then
$$M'_B = -\frac{Wl}{8} \text{ ft. lbs.};$$

$$M''_B = -\frac{wl^2}{12} \text{ ft. lbs.}$$

*After Taylor and Thompson, "Concrete, Plain and Reinforced."

The percentage of reinforcement required by these moments is determined by the methods employed when the steel is in the bottom of the beam and the distance of the steel from the surface of concrete is the same in the two cases. If the beams on both sides of the support are fully loaded, the bending moment for central loads is usually considered to be $\frac{Wl}{8}$ or one-half the moment of a beam supported at the ends, and the moment for uniformly distributed loading to be $\frac{wl^2}{24}$ or one-third the moment of a beam supported at the ends. However, the maximum bending in either of the beams will occur when it is under stress and the beam next to it is not under stress. Mr. A. Considere states that French engineers assume the safe minimum of the moment on the supports to be only $\frac{wl^2}{40}$ basing the resistance at the center of a beam uniformly loaded upon a positive bending moment of $\frac{wl^2}{10}$.

At present, engineers in the United States have generally adopted this rule to be on the safe side. This will in inch pounds be written:

$$M_B'' = \frac{6}{5} wl^2 \text{ inch lbs.} \dots\dots\dots (3)$$

Bending Moments for Slabs.—While the formulas for floor beams and girders are well supported by actual tests, the floor slabs, particularly those reinforced in more than one direction, show frequent inaccuracies of present theories by exhibiting a strength considerably greater than calculated.

The theory of flat plates is so intricate that calculations are not often attempted and comparative tests show that the strength of slabs continuous in both directions is several times greater than slabs supported at the two ends, so that the dimensions and reinforcements may be deduced empirically. Mr. Joseph R. Worcester* in testing floor slabs re-

*Journal Assoc. Engineering Societies, April, 1905; p. 205.

inforced with steel wire, found that the steel, if calculated by the usual theories, attained in one case an apparent tension of 250,000 lbs. per sq. in. before rupture, thus showing the evident inaccuracies of present theories for continuous slabs.

Hennebique* found by tests of floor slabs at the Paris Exposition that the bending moment at the middle of a slab continuous in both directions was less than

$$\frac{wl^2}{36}$$

Meanwhile the building laws of New York permit the calculation of the bending moment of square floor plates, reinforced in both directions and supported on four sides by the formula

$$M_B = \frac{Wl}{20} \text{ ft lbs.}$$

Cross Reinforcement in Slabs.—The author finds that steel rods parallel to the principal supports greatly increase the strength of the slab and render expansion joints unnecessary. In fact, by using a wire fabric a "lateral continuity" is gained which causes the author to use these formulas when building codes will permit:

$$M = \frac{wl^2}{16} \text{ ft. lbs., and}$$

$$M_B = \frac{wl^2}{30} \text{ ft. lbs.,}$$

respectively, for slabs continuous over two supports and over four supports, for uniformly distributed loads, in calculating the middle of the slab, and tests have invariably proved that the dimensions resulting have been ample and safe.

Location of Stirrups in Beams.—The newest theory regarding diagonal cracks in beams attributes them to internal tension caused by a stretching and slipping of the rods employed in the reinforcement. Theoretically, the stirrups

*Beton & Eisen, 1903, Heft I.

should slope 45° away from the center of the beam, although for practical reasons they are frequently set vertically.

Mr. W. J. Schaub uses the following rule in spacing stirrups:*

a = area of steel in stirrup at any section of beam in sq. ins.

bd = total sectional area of beam in sq. in.

p = ratio of area of metal reinforcement to cross section of beam.

pbd = area of horizontal reinforcement.

l = length of beam in feet.

z = distance from end of beam to section where stirrup is located.

$$\text{Then} \quad a = \frac{4pbd}{l} \left(1 - \frac{2z + 1}{l} \right) \dots\dots\dots (4)$$

Example: In a 7-ft. beam the horizontal reinforcement was 0.03655 sq. ins. per 1 in. width of beam. The metal required for stirrups 1 ft. from the end was

$$\frac{4 \times 0.03655}{7} \times \frac{4}{7} = 0.012 \text{ sq. ins. per 1 in. width of beam.}$$

Mr. E. L. Ransome's empirical rule for spacing stirrups is to place the first a distance from the end of a beam corresponding to one-quarter the depth of the beam, the second a distance of one-half the depth of the beam, beyond the first, the third a distance of three-quarters the depth of the beam beyond the second, and the fourth a distance of the depth of the beam beyond the third. Having found this rule very simple, practical and corresponding with calculations, the author generally employs it.

For concentrated loads the stirrups can be figured as for shear, the horizontal shear s being constant and approximately equal to the vertical shear $\frac{W}{2}$ divided by the depth d .

$$s = \frac{W}{2d} \dots\dots\dots (5)$$

*Engineering News, April 16, 1903, p. 348.

In locating stirrups as in a plate girder* the simplest method is to draw the shear diagrams for concentrated and distributed loads. To determine the spacing, an area equal to the adhesion is subtracted from the shear diagram and the remaining area is divided into panels, giving each an area to correspond with the maximum shear allowed for each stirrup. As the height of the panels decreases, their length increases, giving a series of spaces representing graphically the spacing of the stirrup. Thus Fig. 31 represents the shear diagram of a beam with a uniform and a concentrated loading. The area above the line AB represents the shear due to the concentrated load P , and that below the line AB the shear due to the uniformly distributed load—only considering the portion of the shear diagram to the right of the cen-

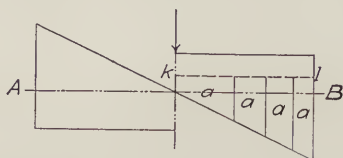

Fig. 31.—Diagram for Locating Stirrups.

ter line of the beam. Then if the area above the dotted line kl represents the allowable stress cared for by the adhesion of the rods, the portion of stress in the diagram below this line must be provided for by stirrups. If this be divided in equal areas, a , one for each stirrup, the horizontal dimensions of the trapezoids, a , will give graphically the desired stirrup spacing.

Adhesion of Concrete to Steel.—The adhesion of concrete to steel depends upon the richness of the concrete and has been found to reach 700 lbs. per sq. in. Where the yield point of the steel is not exceeded, the minimum ultimate adhesion for first-class concrete may be placed at 275 lbs. per sq. in., according to Mr. Paul Christophe, and for a shearing strength of concrete equal to 400 lbs. per sq. in. this cor-

*Reid, Concrete and Reinforced Concrete Construction, p. 311.

responds to a minimum clear distance between rods of about $1\frac{1}{4}$ times the diameters of rods.

Modulus of Elasticity.—The modulus of elasticity of steel varies from 28,000,000 to 31,000,000 lbs. per sq. in., and 30,000,000 lbs. is usually taken as an average value. The modulus of elasticity of concrete varies considerably, from 1,500,000 lbs. per sq. in. to 5,000,000 lbs.

The following tabulation gives an idea of the variation as compared with different proportions:

	Proportions	Modulus of Elast. lbs. per sq. in.
Broken stone or gravel concrete	1— $1\frac{1}{2}$ —3	4,000,000
	1—2—4	3,000,000
	1— $2\frac{1}{2}$ —5	2,500,000
	1—3—6	2,000,000
	1—4—8	1,500,000
Cinder concrete	1—2—5	850,000

However, for graded mixtures considerably higher values may be found.

The higher the modulus of elasticity of the concrete the lower should be the percentage of steel and the greater the depth of the beam for symmetrical design, maintaining fixed relations of pull in steel to pressure of concrete.

Summary of Talbot's Tests on Tee Beams.—From the summary of the discussion* referring to the theory of reinforced concrete tee beams, the following is of particular interest to the designer:

(1) Beams of flange width of 2, 3 and 4 times the width of stem or web and reinforced in each case with steel equal to 1 per cent of the inclosing rectangle (an imaginary rectangle as wide as the flange and as deep as the distance from the centroid of longitudinal metal reinforcement to most strained fiber in compression) exhibited in a common way the characteristics of rectangular beams, and the critical failure in every case came through the longitudinal reinforcement becoming stressed beyond its yield point.

*Prof. A. N. Talbot, Bulletin Univ. of Ill., Feb. 1, 1907.

(2) The full compressive strength of the concrete at the most remote fiber was not developed at the yield point of the beam, even in the beams which were reinforced with steel of 54,000 lbs. per square inch yield point.

(3) The vertical stirrups used proved to be very effective web reinforcement. The diagonal tension cracks appeared at or above loads at which failure by diagonal tension may be expected in beams without web reinforcement. A high resistance to diagonal tensile stresses was developed, as measured by the calculated maximum vertical shearing unit stress, which in one beam was 605 lbs. per sq. in. Since no beam failed by diagonal tension, the limit of strength of the web reinforcement was not determined.

(4) The maximum strength of tee beams to resist horizontal tension and compression (flange stresses) may well be calculated by using the ordinary methods and formulas in use for rectangular beams and considering the inclosing rectangle of the tee beam to be the equivalent rectangular beam. This approximation is at least applicable for reinforcement not exceeding 1 per cent of the inclosing rectangle. It gives little error when the thickness of flange is at least one-fourth of the depth of beam and the width of flange not more than four times the width of stem, and may be used for an even greater range without great error.

FOUNDATIONS.

Types of Foundations.—The type of foundation for a building depends upon the weight of the proposed building and the character of the underlying soil. When the weight of the building has been estimated, the character of the soil will determine the form of foundation. Careful borings should be taken showing location of hard pan or the condition of the different strata, their thickness and water-bearing qualities, which will determine whether piling, caissons, floats or rafts be required. The location and condition of adjacent buildings must be considered, as their maintenance generally devolves upon the contractor for the new structure.

As, however, these conditions and the selection of the foundations required must be met at any event, we shall only describe the most usual methods used in connection with reinforced concrete structures.

Reinforced concrete foundations may be classified as pile, slab, raft, mat, and portable foundations.

Bearing Power of Soils.—The following tabulations, which are self-explanatory, are useful in connection with the designing of foundations; they show the bearing power of soils in tons per square foot:

(From Baker's Masonry Construction.)

Rock, the hardest, thick layers, in native bed.....	200	tons
Rock, equal to the best ashlar masonry.....	25	to 30 tons
Rock, equal to the best brick masonry.....	15	to 20 tons
Rock, equal to poor brick masonry.....	5	to 10 tons
Clay on thick beds, always dry.....	4	to 6 tons
Clay on thick beds, moderately dry	2	to 4 tons
Clay, soft	1	to 2 tons
Gravel and coarse sand, well cemented.....	8	to 10 tons
Sand, compact and well cemented.....	4	to 6 tons
Sand, clean and dry	2	to 4 tons
Quicksand, alluvial soils, etc.	0.5	to 1 ton

(From Building Code, National Board of Fire Underwriters.)

Soft clay	1	ton per sq. ft.
Clay and sand together, wet and springy.....	2	tons per sq. ft.
Loam, clay, or fine sand, firm and dry.....	3	tons per sq. ft.
Very firm coarse sand, stiff gravel or hard clay..	4	tons per sq. ft.

Pile Foundations.—Concrete piling offers many advantages which are not obtained with timber piling. Concrete piles of the same strength and bearing capacity need not be so long as those of wood, and they need not be so numerous. Timber piles, to prevent decay, must be cut off at mean low water, and the footings must be started from this point. With concrete piling, the tops can be left just far enough below the bottoms of the columns to allow for a footing thick enough to carry the superimposed building.

Concrete piles are of two classes: (1) Piles molded in place, and (2) piles molded on the surface and driven after having become hard, as a timber pile is driven. The Raymond and Simplex piles, described here, belong to the first class and the Corrugated and Chenoweth piles belong to the second class.

The Raymond Pile.—This pile, controlled by the Raymond Concrete Pile Co., Chicago, is placed in the ground by the pile core method, which is as follows: A collapsible steel core, encased in a thin, closely fitting sheet steel shell, is driven by a pile driver to the required depth.

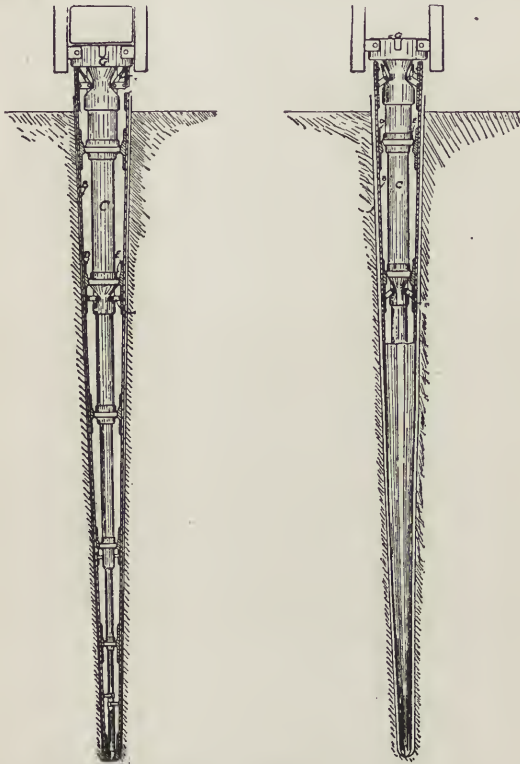

Fig. 32.—Raymond Collapsible Steel Core.

Fig. 32 shows two views of this core, the view to the left showing the shell driver and the core expanded. The view to the right shows the pile core collapsed and ready to be drawn from

the shell. This shell, which is left in the ground, acts as a mold for the concrete, protecting it from back pressure, which would distort the pile, and from the admixture of foreign matter, which would impair the bond of the concrete. An electric light can be lowered at intervals during the placing of the concrete, to enable the operator to see just what condition prevails. When reinforcement is desired, the reinforcing material is inserted in the shell before the placing of the concrete. The piles are tapered to obtain greater bearing value, since the load on a tapered pile is more uniformly distributed along the entire length.

Fig. 32a shows a comparison between wooden piles and concrete piles, where 22 wooden piles and an 8-ft. deep solid concrete pier were replaced by 8 concrete piles and two piers 5 ft. deep connected by an arch construction.

An excellent example of the economy of concrete piles is given in the following extract of a report by Mr. Walter R. Harper, showing a comparison in cost of foundation with wooden piles and with Raymond piles in the Academic building at Annapolis:

The difference in thickness of concrete footings is well illustrated by a section of the footings of the academic building with wood piles and the same section as redesigned and built with concrete piles. This saving in excavation and footings depends upon the height of the building above mean low water. At the Naval Academy the rise and fall of the tide in the Severn river is very slight, consequently the buildings have been placed only a few feet above mean low water. Notwithstanding that the cost per linear foot for concrete piles far exceeds that of wood piles, being about four times as much, the saving in the entire foundation by their use will surprise the uninitiated, as will be seen by a glance at the cuts shown here.

In the diagram, Fig. 32b, the section *E-F* shows the footing of the connection between the library and academic building as designed by Mr. Flagg for wood piles. Another sketch shows the same section, *G-H* in the diagram as built with concrete piles. The depth of footing on this section was re-

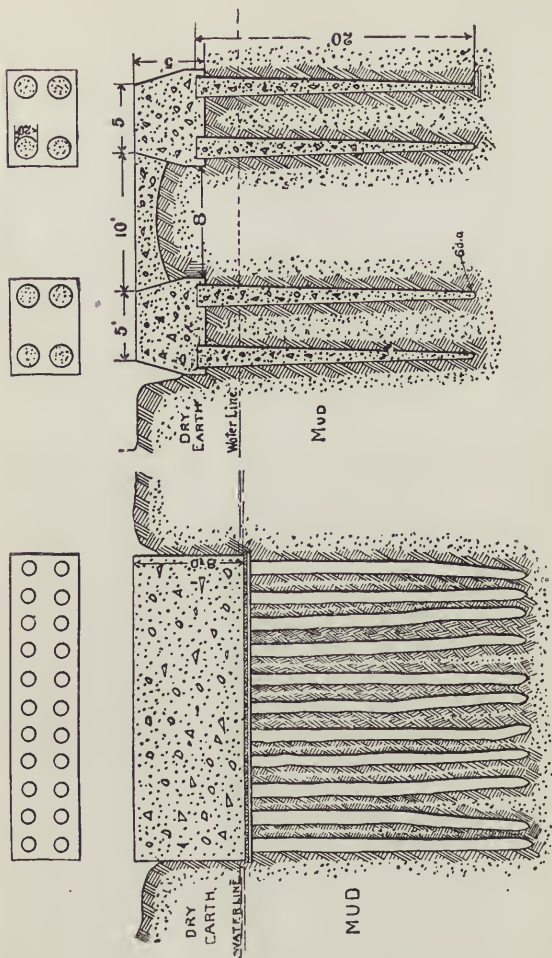

Fig. 32a.

duced from 7 ft. to 2 ft. 8 ins., and the width on the bottom from 12 ft. 1 in. to 5 ft. 2 ins. The area of the cross-section was reduced from 58 to 12 sq. ft. In the plan of the wood piles under the library tower there are 202 piles in a rectangle 38 ft. 5½ ins. square. The plan of the same tower foundation with 84 concrete piles has footings 8 ft. 2 ins. wide.

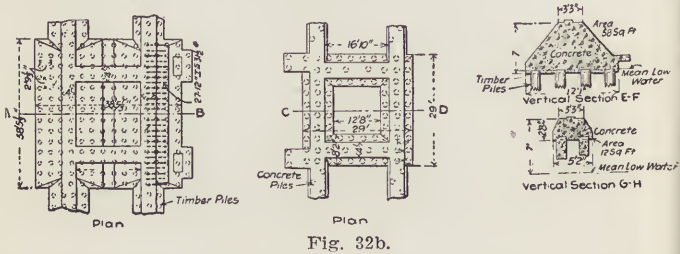

Fig. 32b.

With wood piles it will be noticed that the piles and footings extend over the entire rectangle, while with concrete piles the piles and footings are only 8 ft. 2 ins. wide and directly under the walls of the tower. The depth of the footing was reduced by the use of concrete piles from 10 ft. 1½ ins. to 4 ft. 7⅓ ins. Twenty-seven 12-ins. 31½-lb. I-beams were done away with.

The following reductions on the foundations of the two buildings were by the use of concrete piles: 2,193 wood piles were replaced by 885 concrete piles; 4,542 yds. of excavation were reduced to 1,038 yds., saving 3,504 yds., and 3,250 yds. of concrete footings were reduced to 986 yds., saving 2,264 yds.

With wood piles, after excavating to mean low water, shoring and pumping would have been necessary in all trenches, and this saving was estimated at \$4,000. A schedule of changes showing the saving by the use of concrete piles is given in the accompanying tabulation.

The saving in the cost of foundations by the use of concrete piles was \$27,458.18, or more than half of the original cost of the foundations, as designed with wood piles.

COMPARATIVE COST OF WOOD AND CONCRETE PILES.

	at	Wood Piles.	
2,193 piles	\$9.50	\$20,835.50	
4,542 cu. yds. excavation.....	.40	1,816.80	
3,250 cu. yds. concrete.....	8.00	26,000.00	
5,222 lbs. I-beams.....	.04	208.88	
Shoring and pumping.....		4,000.00	
Total cost			\$52,861.18
	at	Concrete Piles.	
855 piles	\$20.00	\$17,100.00	
1,038 cu. yds. excavation.....	.40	415.00	
986 cu. yds. concrete.....	8.00	7,888.00	
Shoring and pumping.....			
Total cost			\$25,403.00
Difference in cost			\$27,458.18

The estimate of length of wood piles was taken from the length of wood piles driven in the marine engineering building, a structure about 200 ft. from the library site. Wood piles would have been required 40 ft. in length at a cost of 20 cts. a foot, and would have been on an average driven 30 ft. below mean low water, which at 5 cts. a foot would mean an average cost of \$9.50 per pile.

For the estimate of excavations it was assumed that the entire site was at an elevation of 7 ft. above mean low water, which is an average of the existing conditions.

The longest concrete pile driven was 29.7 ft., but owing to the solid nature of the soil at the southerly end of the library building, where shorter piles were used, the average length was 16 ft., and the cost of the concrete piles was taken at \$20 per pile.

The concrete pile selected was that of the Raymond Concrete Pile Co., of Chicago. It is conical in shape, running from 6 ins. in diameter at the bottom to 20 ins. at the top. Owing to this conical shape the ground is compacted and a much shorter pile can be used with this style than with a cylindrical pile. The difference in bearing power between a conical and a cylindrical pile was shown by an experiment tried on this work at the Naval Academy. A Raymond pile core tapered from 6 ins. at the point to 20 ins. at the head, was driven 19 ft. until the penetration under two blows from a 2,100-lb. hammer falling 20 ft. was 7/8 in. A wood pile 9 1/2 ins. at the point and 11 ins. at the head and having the same length, 19 ft., as the con-

ical pile, had a penetration of 5 5-16 ins. under two blows of the same hammer, falling 20 ft. This pile was driven after the concrete pile and about 2 ft. from it, thus showing the comparative bearing power between a conical and a cylindrical pile of the same length.

These piles of the Raymond style are driven by the use of a hollow steel core 6 ins. in diameter at the point and 20 ins. at the head. The cores used on this work were 20 and 30 ft. in length. The exterior pieces of the core are spread and held in place during the driving by a wedge device. The core is held in the leads of the pile driver by steel plates, fastened to its top, which form guides to slide in the leads. The top of the steel core is protected by a hardwood cap block, which sets in a cavity made for it. This block receives the blow of the hammer and has to be renewed from time to time.

The sheet-steel shells are formed on the work in an extra heavy cornice brake machine, and are made in 8-ft. sections with locked seams. The sections are telescoped, the point of the core is raised about 8 ft. and inserted in the smallest section, then the other sections are drawn up around the core by a line from the hoisting engine on the driver. Two drivers were used on the work at the Naval Academy, one with a 2,240-lb. drop hammer and the other a steam hammer of the Vulcan make, weighing 3,000 lbs. The steam hammer was found more satisfactory, working much more rapidly. This was partly due to the fact that the steam hammer was mounted on a turn-table, and was able to turn in a circle by its own power. It was also provided with an extension top by which the core could be raised or lowered, if necessary, in a trench below the driver.

The Simplex Pile.—The Simplex pile, controlled by the Simplex Concrete Piling Co., Philadelphia, is constructed as follows: A wrought iron driving pipe of the diameter and length of the intended pile, and of sufficient strength to withstand driving, with a point made of cast iron or steel and a hardwood driving head which protects the pipe from injury during driving, is driven to a firm bearing, and the pipe is withdrawn and the hole filled with concrete. Fig. 33.

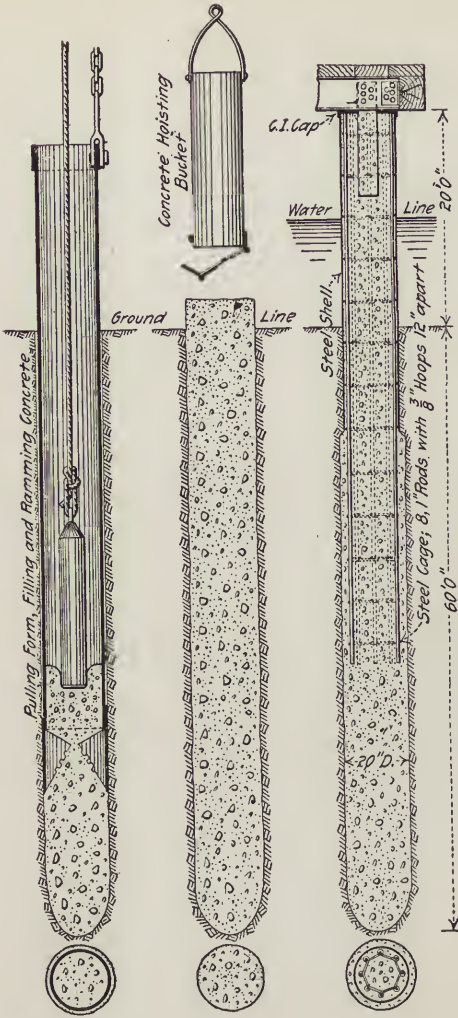

Fig. 33.—Construction of Simplex Piles.

The Corrugated Pile.—The Corrugated Concrete Pile Co. of New York manufactures piles which are polygonal in section and are corrugated longitudinally like a fluted column. Fig. 34. There is a hole extending the length of the pile, so that it can be driven by water jet, the water being forced down through the hole and returning along the corrugated sides.

The Chenoweth Pile.—This pile, shown in section by Fig. 35, is manufactured by Mr. A. C. Chenoweth, Brooklyn, N. Y., by spreading a layer of concrete on wire mesh and rolling both together by a special machine into a solid pile with a gas pipe core or center.

Other Forms of Piles.—Various patented forms of concrete piles besides those mentioned above are on the mar-

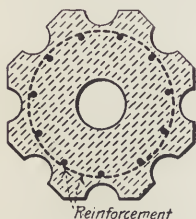

Fig. 34.—Section of Corrugated Pile.

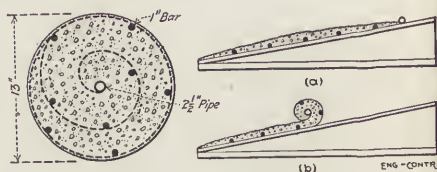

Fig. 35.—Chenoweth Pile.

ket. In addition the builder is free to mold square, round or polygonal piles reinforced by longitudinal bars, hooping, etc., in practically any way desired, and such piles have been used in great numbers.

Pile Driving.—Concrete piles may be driven by jetting like timber piles, using exactly the same methods and apparatus. Concrete piles may also be driven by hammers, using pile drivers of the ordinary type, but equipped to handle the heavier concrete pile. Care is required in hammer driving. The pile must be maintained exactly in line with the direction of the hammer blow, a heavy hammer and a short drop must be employed, and the head of the pile

must be protected by a special cap to cushion the hammer blow.

For a full discussion of the methods of molding and driving concrete piles and for detailed costs of pile foundation work the reader is referred to "Concrete Construction—Methods and Costs," by Gillette and Hill.

Slab Foundations.—Slab foundations are of two kinds, self-contained, rectangular slabs, and rafts, where two or more columns are supported on one slab so constructed that the center of gravity of the slab coincides with that of the superimposed loads in a manner to have the weight of the superstructure practically a constant on the underlying soil. Such foundations were designed by the author for the new Battle House, Mobile, Ala., the architects being Frank H. Andrews Co., Cincinnati, O. The advantages of connecting all separate footings by a reinforced concrete grillage are illustrated under Example of Building, page 141.

For rectangular slabs, such as column foundations, the simplest construction is to run the reinforcement by diagonals and squares, and after deducting the area of the column base, to consider the remainder of the slab as eight cantilevers, four running parallel to the sides and four on the diagonals, assuming one-eighth of the load for each section, and calculating the reinforcement for each overhang as a uniformly loaded cantilever. A close approximation is found by selecting the size of rods and dividing the four outsides of the base into equal parts, as many as are required to meet the steel area calculated, and draw in the rods accordingly. The diagonal rods will in this manner come closer together to compensate for their longer leverage. The thickness of the slab is calculated to meet the compressive stresses, the same as in any beam, and the horizontal shear likewise.

In most cases the horizontal shear will be taken care of by the concrete except for very heavy structures. As a rule, it is advisable to step off a column footing rather than to batter it, the steps conforming to the theoretical parabola, as shown

by Fig. 36, owing to the saving in labor and the convenience in tamping, and the layers can be arranged to follow one another directly. Another method for piers is to stiffen the slabs by brackets on top, as was done in the foundations at the terminal station, Atlanta, Ga.

Raft Foundations.—To show the value of a raft foundation for treacherous soil, a brief description is here given of the foundation for the Co-operative Wholesale Society, Ltd., at Newcastle-on-Tyne, England. The building rises above the quay-level on which it abuts, and consists of base-

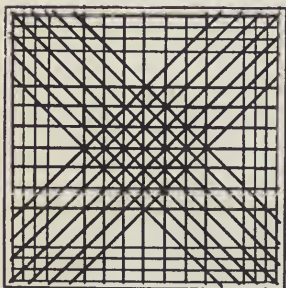

Fig. 36.—Plan and Section of Column Footing.

ment, ground-floor and six upper floors. The frontage is 92 ft. and the depth 125 ft. The subsoil was of the poorest quality for foundations, consisting of 18 ft. of made ground, principally clay, 18 ft. of silt and quicksand, 10 ft. of soft clay, 5 ft. of hard clay, 10 ft. of silty sand and finally gravel. The above stratification had a decided dip toward the river Tyne. To carry the enormous weight of the building, several plans for foundations were proposed. It was at first intended to construct the building of brick on a foundation of cylinders 6 ft. 6 ins. in diameter, sunk from 20 to 62 ft. below the ground level, carrying a sill of concrete 4 ft. thick reinforced with rails. Another alternative consid-

ered was the driving of piles to the same depth, but the liability of injuring the adjoining property proved this method inadvisable. Finally, both these projects were abandoned and it was decided to construct a raft of reinforced concrete over the whole area of the ground. This raft, as constructed, measures 2 ft. 6 ins. in its thickest part and only 7 ins. in the

thinnest part, as shown by Fig. 37. The entire site is divided up into rectangles measuring generally 14 ft. 8 ins. by 14 ft. 6 ins. Each side of these rectangles is a reinforced concrete beam 6 ft. 6 ins. deep by 2 ft. 5 ins. wide at the bottom, the reinforcement being according to the Hennebique system.

The steel reinforcement along the bottom of the mid-spans consists of ten $1\frac{1}{2}$ -in. round rods. At the end of each beam half of the bars are carried up to the upper surface, this arrangement being a characteristic feature of the Hennebique system. Light steel stirrups also extend from around the bottom bars up to the upper surface, in the ordinary manner, thus tying the concrete together in a ver-

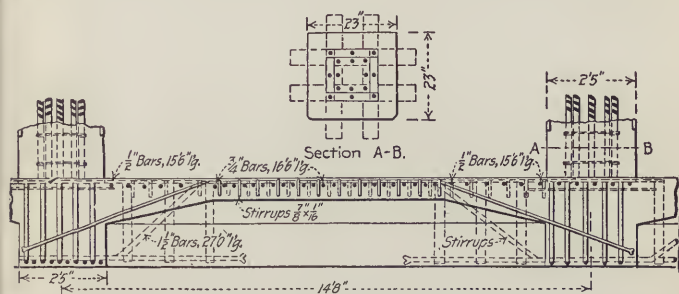

Fig. 37.—Raft Foundation for Warehouse, New Castle-on-Tyne, England.

tical direction. The concrete floor filling in each rectangle is constructed on practically the same system; but the bars used are of much lighter section, being in some cases $\frac{1}{2}$ -in. and in others $\frac{3}{4}$ -in. in diameter. The columns which support the upper floors are also of reinforced concrete. They are placed at the corners of the foundation "squares." The reinforcement here is of 2-in. bars, which are carried right into the foundation. At higher levels, where the total load to be carried is naturally less, the reinforcement is, of course, much lighter, the weight of steel used and the size of the

columns being accurately proportioned to the load to be carried. At the foundation level the columns measure 29 ins. square, and diminish to 8 ins. at the sixth floor. Thus, if settlement takes place, the entire building settles as a solid block, and therefore cannot suffer any deterioration from unequal settlement. In the particular case of this warehouse, there has been a settlement of $3\frac{1}{2}$ ins. at the front and of 3 ins. at the rear, which took place between the date of construction of the foundations and of the first floor. Since then no further settlement has taken place, nor is any anticipated.

Mat Foundations.—In this construction the building may be considered as turned upside down and the bearing power of the soil be considered as an evenly distributed load resting on the columns, in a manner similar to that used in the mushroom system of Mr. C. A. P. Turner, Minneapolis, illustrated by Fig. 55, p. 92. The mat should first be laid down, preferably a wire fabric, near the top of a 4 or 6-in. layer of concrete, and the regular slab foundation supported on and connected to it. This will tie all foundations together in a most effective manner, will facilitate damp-proofing and, as a rule, prove an economical construction.

Portable Foundations.—Incidental to railroad construction, a number of similar buildings are often erected along the line, such as small depots, water stations, tool sheds, corn cribs, coal trestles, semaphores, switch and signal structures, etc., which require concrete foundations and where cement and aggregates must be shipped in by the railroad in too small quantities for economy and proper care-taking. In such cases portable foundations of reinforced concrete can be manufactured at a location on the line where sand and gravel are plentiful and where there can be a good cement warehouse. These portable foundations, Fig. 38, are built of one small top plate and one larger bottom plate, connected by diagonal ribs into the form of a truncated square pyramid and provided with holes and sockets for holding down bolts. The hole for the pier is dug as usual, the foundation lowered into position and steadied at the

proper level, then the backfilling is washed in and tamped, and being practically of the same weight as the concrete, will serve the same purpose, with the difference that only a small fraction of the material has been hauled from a distance.

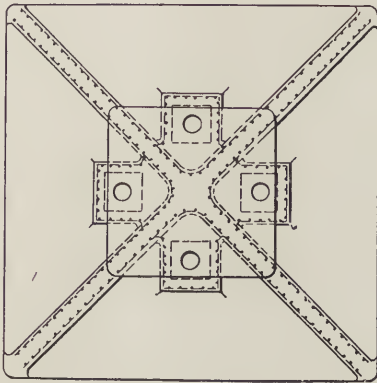
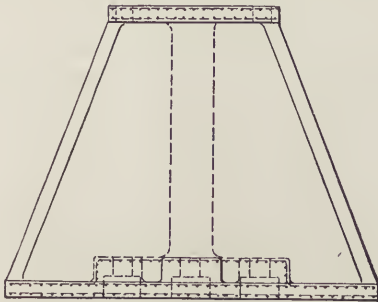

Fig. 38.—Heidenreich Portable Foundation.

These plates and ribs should be made of a rich concrete about 1-4, with aggregates of maximum density, and reinforced with two layers of wire fabric in each plate or rib, with all vertical fabric tied to the horizontal where they join.

Such structures can be moved without destroying the foundations or leaving them, and in the author's opinion portable foundations will with the increase of manufactured articles in reinforced concrete form a very considerable item.

FLOORS.

Floor Loads.—The construction of reinforced concrete floors depends upon their purpose and the live loads that are to be supported, whether quiescent, moving or with im-

TABLE XXXVII.—FLOOR LOADS FOR BUILDINGS, IN POUNDS PER SQUARE FOOT.

CLASS OF BUILDINGS	Bldg. Code, Nat'l Board of Fire Underwriters 1905	New York 1906	Chicago 1905	Philadelphia 1904	St. Louis	San Francisco 1906
Dwellings, tenements, apartments, flats.....	60	60	40	70	60	60
Hotels, lodging houses.....	60	60	50	70	60
Offices, all floors except first floor.....	75	75	50	100	70	75
Offices, first floor.....	150	15	150	150
Schools.....	75	75	75	100	75
Stables and carriage houses	75	75	75
Public assembly.....	90	90	100	120	100	125
Stores.....	120	120	100	120	120
Light manufacturing and storage.....	120	120	100	120	250
Heavy storage, warehouses.	150	150	100 or more	150	150	250 or more
Factories, manufacturing, commercial.....	150 or more	150 or more	100 or more	150	150	250 or more

part. Different cities specify different loads for the several classes of buildings, as may be seen from Table XXXVII.

Table XXXVIII shows the weight per cubic foot of various substances, which are stored in warehouses.

TABLE XXXVIII.—WEIGHT OF VARIOUS SUBSTANCES STORED IN WAREHOUSES.

	Lbs. per cu. ft.
Wheat	50
Beans, peas, etc.....	58
Flour in bulk.....	36
Preserved meats	35
Loose hay	5
Baled hay	20
Loose straw	5
Paper in layers.....	80
Books in layers.....	58
Clothing in layers.....	43
Hardwood in layers.....	29
Coke	23
Coal	100
Loose snow	14
Tamped snow	58

Factor of Safety.—As a rule for floors, the factor of safety is taken as the dead load plus four times the live load, divided by the actual total floor load.

Classification.—A great number of floor constructions have developed both in Europe and in the United States. In general they belong to the following classes:

- (1) Slab Floors, running from girder to girder.
- (2) Beam Floors, with short span slabs.
- (3) Beam and Tile Floors with tiles between beams, making a flat ceiling.
- (4) Arched Floors, with or without cinder filling.
- (5) Manufactured Floors, not made in situ.
- (6) Floors without Beams or Girders, "mushroom" system.

Slab Floors.—This is the simplest type of reinforced concrete floor, and consists of a slab resting on I-beams, which may or may not be encased in concrete, and the slabs may be carried on either the top or the bottom flange of the beam, or on both. In the second case, the space to the top of the beams may be filled with cinder concrete, and in the latter case, a cinder filling may be employed or the space left as an air space. The reinforcement may consist of wire fabric, expanded metal, or loose rods or wires inserted singly and tied. The first two are most used in America. The reinforcement may be placed along the lower part of

the slab, may curve from the bottom of the slab at mid-spans to the top over the support; or two sets of reinforcement may be used, one in the upper and one in the lower part of the slab.

Expanded metal floors are very extensively used in the United States, as they are easy to construct and are eminently satisfactory. Fig. 39 shows a common type of ex-



Fig. 39.—Expanded Metal Floor Slab.

panded metal floor, with one of the beams left exposed, and the other protected by being encased in three reinforced slabs.

The Columbian slab floor, illustrated by Fig. 40, is reinforced with bars resembling a double cross in section, which are suspended from the top flange of the I-beam either

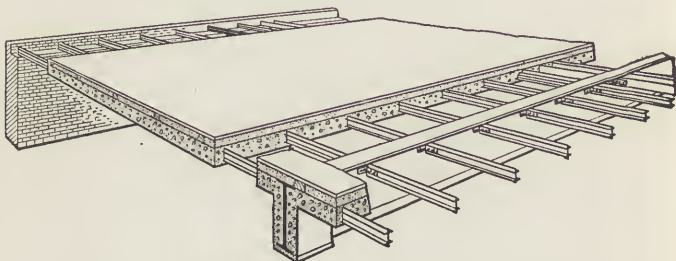

Fig. 40.—Columbian Slab Floor.

by a hanger, which is shown by Fig. 41, or are riveted to the web of the beam, as shown by Fig. 40.

Monier reinforcement, Fig. 42, is much used in Europe. It consists of carrying rods in the direction of the span and distributing rods of lighter weight crossing same, often with an additional trellis near the top surface of the slab. The

rods in each netting are tied together at intervals, usually with No. 18 annealed wire.

The Cottancin system is similar to the Monier, but the carrying and distributing rods are of the same size and are interlaced, as shown by Fig. 43.

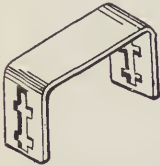

Fig. 41.—Hanger for Columbian Bars.

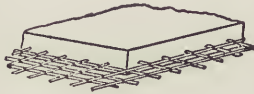

Fig. 42.—Monier Slab Floor.

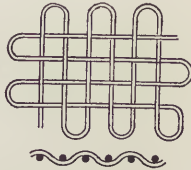

Fig. 43.—Cottancin Reinforcement.

The Roebling slab floor is of many types, a common form being that illustrated by Fig. 44. The reinforcement is flat bars, which are bent at the beams so as to connect with the flange, as shown. Spacers supply the place of dis-

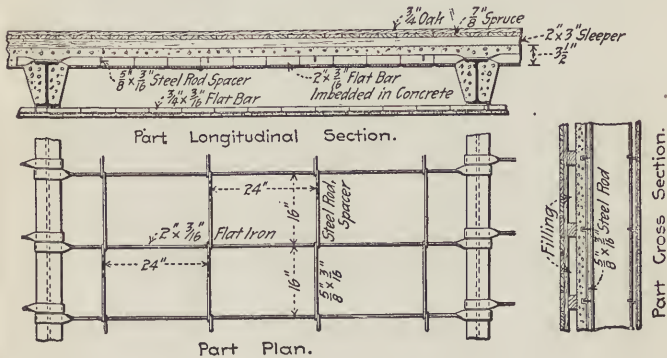

Fig. 44.—Roebling Flat Slab Floor.

tributing rods, and are fitted into slots in the bars. Spans may be constructed up to 16 ft.

The Matrai system, Fig. 45, has wires suspended from fixed points and allowed to assume the form of catenary

curves, the wires crossing diagonally as well as in series parallel to both sides of the frame work.

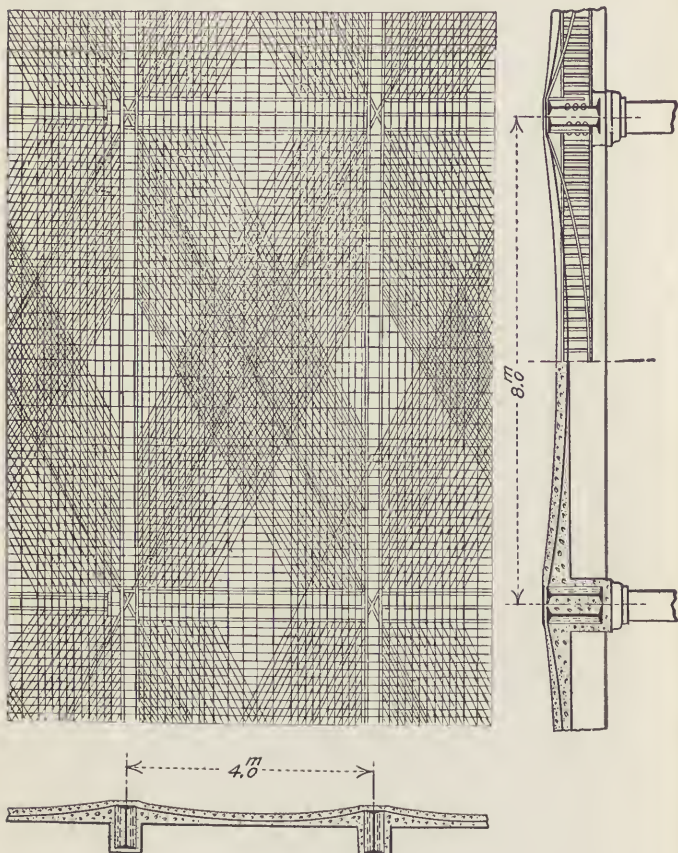

Fig. 45.—Matrai Floor.

In either of the above fabric systems, additional carrying rods and distributing rods are usually laid in to make

up for such steel areas as may be required over and above the section furnished by the manufactured article.

Beam Floors.—Beam floors are those in which the beams as well as the slabs are of reinforced concrete and are built in one piece with the slab. Constructions vary, but generally the floor system consists of main girders carried by columns, intermediate beams or joists carried by the main girders and the covering floor slab in one piece with both beams and girders. Figure 46 shows a fairly typical beam floor.

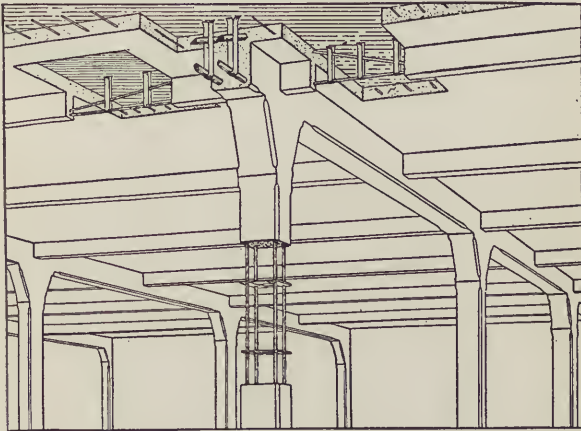

Fig. 46.—Hennebique Floor with Single Reinforcement.

The slab reinforcement may be of any of the forms described in the preceding section, and the girder reinforcement may be either loose rods or framed units. Several forms of unit frames for girder reinforcement are described in Chapter I. When loose rods are used the arrangement consists of straight and bent rods in some form of alternation with, in many types of construction, vertical or inclined stirrups anchoring the straight rods up into the concrete above.

using the Kahn bar as reinforcement, and Fig. 49 shows a combination type employed by the National Fireproofing Co. of Chicago.

Arch Floors.—In arched floors the different fabrics are employed as for slab floors and are usually laid between structural steel girders or beams. A flat ceiling is obtained by suspending metal lathing from beam to beam and plastering.

A Roebling arch floor, with both flat and curved ceilings, is shown by Fig. 50.

The Wuensch arch floor, Fig. 51, is reinforced with angle or tee-iron riveted to the I-beams. This gives a very strong floor.

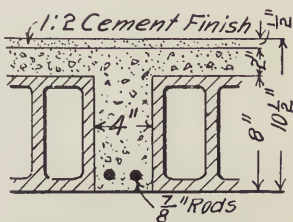

Fig. 49.—Beam and Tile Floor, National Fireproofing Co.

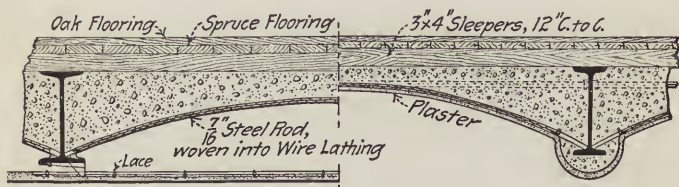

Fig. 50.—Roebling Arch Floor.

The Monier arch floor is reinforced with Monier netting, either one or two sets of netting being employed. A very heavy floor is obtained by placing the upper netting in an



Fig. 51.—Wuensch Arch Floor.

arch, and filling to a flat top with lean concrete. Fig. 52 shows both the single and the double arch construction.

Manufactured Floors.—Among manufactured floors a great number of varieties have appeared abroad and are gradually gaining ground in the United States.

The Siegwart system, Fig. 53, consists of a hollow beam reinforced by round rods, its top face forming the floor slab, and its bottom face the ceiling. The sections are 10 ins. wide with corrugated sides and the spaces are filled with

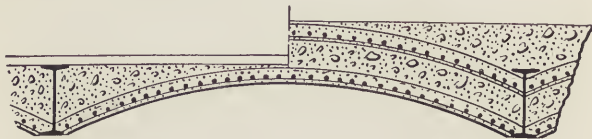

Fig. 52.—Single and Double Arch Monier Floor.

mortar. These floors cost from 15 to 20 cts. per square foot, according to span and load.

The Visintini system, Fig. 54, is also used in the construction of floors and roofs and consists of shallow beams molded in advance. Floors are made up of a series of these beams placed side by side, usually 6 to 12 ins. wide and 6

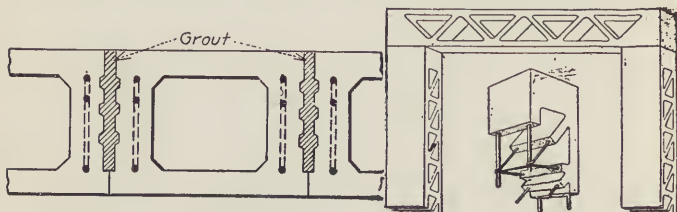

Fig. 53.—Siegwart Hollow Beam.

Fig. 54.—Visintini Beams.

to 8 ins. in depth. In appearance they are Warren trusses with no reinforcement for the web members which are stressed in compression. For deep trusses spanning from column to column and supporting the floor slabs usually Pratt trusses are used, where the verticals are in compression and not reinforced.

The fact that a manufactured floor can be dismantled without complete destruction, and besides can be manufac-

tured under roof at any time and erected rapidly with a great saving in scaffolding and labor, will doubtless before long bring this construction prominently before owners and contractors.

Floors Without Beams or Girders.—Floors without beams or girders are illustrated by the “mushroom” system, which

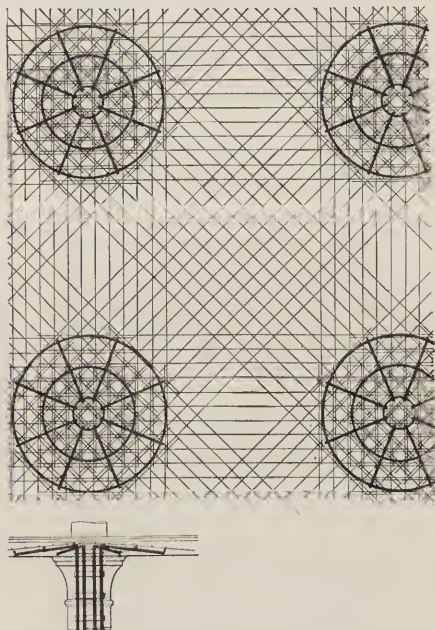

Fig. 55.—Floor Slab Reinforcement, Mushroom System.

is an adaptation of the Matrai system, excluding beams or girders, the head of the columns being curved out to receive a large floor area directly. This system is patented by Mr. C. A. P. Turner, Minneapolis, Minn. The columns are octagonal or cylindrical, and the floor panels are built up to 16x24 ft., or 16x26 ft. The floor loads sustained are from

200 to 1,000 lbs. per sq. ft. Fig. 55 shows the floor and column reinforcement.

Calculation of Slabs.—The tables for calculation of floors and beams closely conform to the theory developed by Prof. A. N. Talbot*, and have been adapted to such ratio of moduli of elasticity and permissible stresses as have been adopted by New York building regulations. Other tables show results for richer concrete and other unit stresses, also other ratio of moduli permissible under such conditions. The table based upon the parabolic stress-line deformation is given for comparison.†

Notation:—

b = breadth of flange or tee-beam in inches

d = distance from the compressive face to the center of the metal reinforcement

h = thickness of beam or slab

p = ratio of area of metal reinforcement to area of inclosing rectangle above center of reinforcement

E_s = modulus of elasticity of the steel

E_c = initial modulus of elasticity of concrete in compression

$n = \frac{E_s}{E_c}$ = ratio of moduli of elasticity of steel and concrete

f = tensile stress per sq. in. in metal reinforcement

C = compressive stress per sq. in. in compression face of concrete at most remote fiber

s = horizontal shearing stress per sq. in. in concrete

k = ratio of distance between compressive face and neutral axis to distance d

M_c = resisting moment of concrete

M_s = resisting moment of metal reinforcement

*Test of Reinforced Concrete Tee Beams, Univ. of Ill. Bulletin, Feb. 1, 1907.

†See also Taylor & Thompson, "Concrete, Plain and Reinforced."

K_c , K_s and S are constants, varying in direct proportion with c , f and s

K = the smaller of the two values K_c and K_s

V = safe vertical shear at a given section in lbs.

M = safe bending moment at a given section in inch pounds

$$M = Kbd^2 \dots \dots \dots (6)$$

$$V = Sbd \dots \dots \dots (7)$$

$$S = s(1 - \frac{1}{3}k) \dots \dots \dots (8)$$

Straight Line Formula.—Assumption for New York (see Fig. 56).

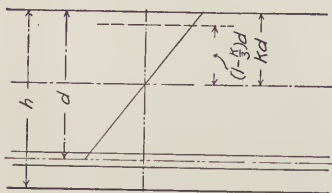

Fig. 56.—Straight Line Diagram.

$$C = 500 \text{ lbs. per sq. in.}$$

$$s = 50 \text{ lbs. per sq. in.}$$

$$f = 16,000 \text{ lbs. per sq. in.}$$

$$p = \frac{\text{Area of steel}}{bd}$$

$$k = \sqrt{2np + n^2p^2} - np \dots \dots \dots (9)$$

$$M_c = \frac{1}{2}Ck \left(1 - \frac{k}{3}\right) bd^2 \dots \dots \dots (10)$$

$$M_s = pf \left(1 - \frac{k}{3}\right) bd^2 \dots \dots \dots (11)$$

$$V = s \left(1 - \frac{k}{3}\right) bd \dots \dots \dots (12)$$

$$K_c = \frac{1}{2} C k \left(1 - \frac{k}{3}\right) \dots \dots \dots (13)$$

$$K_s = p f \left(1 - \frac{k}{3}\right) \dots \dots \dots (14)$$

K = the smaller of the two values K_c
and K_s

Table XXXIX gives values of K for various proportions of steel used in designing concrete beams, slabs, etc.

TABLE XXXIX.—VALUES OF K FOR VARIOUS PROPORTIONS OF STEEL
USED, WHEN $C = 500$, AND $f = 16,000$.

$n=12.$						$n=15.$				
p	k	$1 - \frac{k}{3}$	K_c	K_s	K	k	$1 - \frac{k}{3}$	K_c	K_s	K
.001	.143	.952	35.8	15.2	15.2	.158	.947	37.6	15.2	15.2
.002	.196	.935	45.8	29.9	29.9	.215	.928	50.0	29.6	29.6
.003	.235	.922	54.2	44.3	44.3	.258	.914	58.9	43.8	43.8
.004	.266	.911	60.2	58.4	58.4	.291	.903	65.8	57.8	57.8
.005	.291	.903	65.8	72.2	65.8	.319	.894	71.2	71.4	71.2
.006	.314	.896	70.3	86.0	70.3	.343	.885	76.2	84.8	76.2
.007	.334	.889	74.2	99.5	74.2	.366	.878	80.3	98.6	80.3
.008	.352	.883	77.7	113.0	77.7	.384	.872	83.8	111.7	83.8
.009	.370	.877	81.1	126.1	81.1	.401	.866	86.9	124.7	86.9
.010	.384	.872	83.8	139.8	83.8	.417	.861	90.0	137.8	90.0
.011	.398	.867	86.4	152.5	86.4	.432	.856	92.4	150.6	92.4
.012	.411	.863	88.8	166.	88.8	.444	.852	94.8	163.8	94.8
.014	.435	.855	93.0	192.	93.0	.470	.843	99.1	188.5	99.1
.016	.456	.848	96.7	217.	96.7	.492	.836	103.0	214.0	103.0
.018	.476	.841	100.0	243.	100.	.513	.829	106.0	238.3	106.0
.020	.493	.836	103.	267.	103.	.530	.823	108.8	263.2	108.8
.030	.561	.813	114.	390.	114.	.600	.800	120.0	384.	120.0
.040	.610	.796	122.	510.	122.	.650	.784	127.6	502.	127.6
.050	.650	.783	127.	628.	127.	.680	.774	131.8	620.	128.2

Where high carbon steel is used as a reinforcement with a rich concrete, we may assume $f=20,000$ and $C=700$. Table XL uses these values. The selection of the value of n depends upon the bulk of the concrete as E_c assumes a higher value for light constructions than for heavy ones.

TABLE XL.—VALUES OF K FOR VARIOUS PROPORTIONS OF STEEL USED WHEN $C=700$, AND $f=20,000$.

$n=12$						$n=15$				
p	k	$1-\frac{k}{3}$	K_c	K_s	K	k	$1-\frac{k}{3}$	K_c	K_s	K
.001	.145	92.5	53.7	19.1	19.1	.158	94.7	56.4	19.1	19.1
.002	.196	93.5	68.6	37.4	37.4	.215	92.8	75.0	37.1	37.1
.003	.235	92.2	81.2	55.3	55.3	.258	91.4	88.4	54.8	54.8
.004	.266	91.1	90.3	72.9	72.9	.291	90.3	98.7	72.2	72.2
.005	.291	90.3	98.7	90.3	90.3	.319	89.4	106.8	89.4	89.4
.006	.314	89.6	105.4	107.5	105.4	.343	88.5	114.3	106.2	106.2
.007	.334	88.9	111.3	124.5	111.3	.366	87.8	120.4	122.9	120.4
.008	.352	88.3	116.5	141.2	116.5	.384	87.2	125.7	139.5	125.7
.009	.370	87.7	121.6	157.9	121.6	.401	86.6	130.3	155.9	130.3
.010	.384	87.2	125.7	174.4	125.7	.417	86.1	135.0	172.2	135.0
.011	.398	86.7	129.6	190.7	129.6	.432	85.6	138.6	188.3	138.6
.012	.411	86.3	133.2	207.1	133.2	.444	85.2	142.2	204.5	142.2
.014	.435	85.5	139.5	239.4	139.5	.470	84.3	148.6	235.6	148.6
.016	.456	84.8	145.0	271.4	145.0	.492	83.6	154.5	267.6	154.5
.018	.476	84.1	150.0	302.8	150.0	.413	82.9	159.0	298.4	159.0
.020	.493	83.6	154.5	334.4	154.5	.530	82.3	163.2	329.2	163.2
.030	.561	81.3	171.	487.8	171.	.600	80.0	180.0	480.	180.0
.040	.610	79.6	183.	636.8	183.	.650	78.4	191.4	627.	191.4
.050	.650	78.3	190.	783.0	190.	.680	77.4	197.7	774.	197.7

For bulky concrete constructions, such as bridge abutments or very heavy slab floors, E_c has a lower value and in such cases we make $n=20$ or even more. Table XLI is calculated for these conditions.

TABLE XLI.—VALUES OF K FOR VARIOUS PROPORTIONS OF STEEL USED WHERE $C = 700$, AND $f = 16,000$.

p	$n = 10$					$n = 20$				
	k	$1 - \frac{k}{3}$	K_c	K_s	K	k	$1 - \frac{k}{3}$	K_c	K_s	K
.001	.132	.956	44.2	15.3	15.3	.181	.879	55.7	14.06	14.06
.002	.190	.937	62.3	30.0	30.0	.246	.836	72.0	26.8	26.8
.003	.217	.928	70.5	44.6	44.6	.292	.805	82.3	38.6	38.6
.004	.246	.918	79.0	58.8	58.8	.328	.781	89.7	50.0	50.0
.005	.270	.910	86.0	72.8	72.8	.358	.761	95.4	60.9	60.9
.006	.292	.903	92.3	86.7	86.7	.384	.744	100.0	71.4	71.4
.007	.311	.896	97.5	100.4	97.5	.407	.729	103.8	81.6	81.6
.008	.328	.890	102.2	113.9	102.2	.428	.715	108.1	91.5	91.5
.009	.344	.885	106.6	127.4	106.6	.447	.702	109.8	101.1	101.1
.010	.358	.881	110.4	140.9	110.4	.463	.691	112.0	110.6	110.6
.011	.372	.876	114.1	154.2	114.1	.479	.681	114.2	119.9	114.2
.012	.384	.872	117.2	167.4	117.2	.493	.671	115.8	128.8	115.8
.014	.389	.870	118.5	194.9	118.5	.519	.654	118.8	146.5	118.8
.016	.428	.857	128.4	219.4	128.4	.542	.639	121.2	163.6	121.2
.018	.446	.851	132.8	245.1	132.8	.562	.625	122.9	180.0	122.9
.020	.463	.846	137.1	270.7	137.1	.580	.613	124.4	196.2	124.4
.030	.531	.823	153.0	395.0	153.0	.65	.567	129.0	272.2	129.0
.040	.580	.807	163.8	516.5	163.8	.70	.534	130.8	341.8	130.8
.050	.618	.794	171.7	635.2	171.7	.73	.514	131.3	411.2	131.3

Parabolic Line Formula.—Assumptions for New York.
(See Fig. 57.)

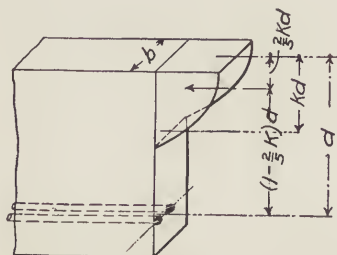

Fig. 57.—Parabolic Line Diagram.

$$C = 500 \text{ lbs. per sq. in.}$$

$$s = 50 \text{ lbs. per sq. in.}$$

$$f = 16,000 \text{ lbs. per sq. in.}$$

$$n = 10$$

$$k = \frac{3}{4} (\sqrt{pn(\frac{n}{3} + pn)} - pn) \dots\dots\dots(15)$$

$$M_c = \frac{2}{3} Ck (1 - \frac{2}{3}k) b d^2 \dots\dots\dots(16)$$

$$M_s = pf (1 - \frac{2}{3}k) b d^2 \dots\dots\dots(17)$$

$$V = s (1 - \frac{2}{3}k) b d \dots\dots\dots(18)$$

$$K_c = \frac{2}{3} Ck (1 - \frac{2}{3}k) \dots\dots\dots(19)$$

$$K_s = pf (1 - \frac{2}{3}k) \dots\dots\dots(20)$$

$K =$ the smaller of the two values K_c and K_s

$$S = s (1 - \frac{2}{3}k) \dots\dots\dots(21)$$

TABLE XLII.—VALUES OF K FOR VARIOUS PROPORTIONS OF STEEL USED WHEN $C=500$ AND $f=16,000$.

p	k	$1 - \frac{2}{3}k$	K_c	K_s	K	S
.001	.115	.954	36.6	15.3	15.3	47.7
.002	.159	.936	49.6	30.0	30.0	46.8
.003	.191	.924	58.7	44.3	44.3	46.2
.004	.217	.913	66.0	58.3	58.3	45.6
.005	.239	.904	72.0	72.4	72.0	45.2
.006	.258	.897	77.2	86.1	77.2	44.8
.007	.276	.890	81.8	99.6	81.8	44.5
.008	.292	.883	85.9	113.1	85.9	44.2
.009	.306	.878	89.5	126.4	89.5	43.9
.010	.320	.872	92.9	139.6	92.9	43.6
.012	.344	.862	98.8	165.6	98.8	43.1
.014	.365	.854	103.9	191.3	103.9	42.7
.016	.384	.846	108.4	216.6	108.4	42.3
.018	.402	.839	112.4	241.7	112.4	42.0
.020	.418	.833	116.0	266.5	116.0	41.6
.030	.483	.807	129.8	387.4	129.8	40.4
.040	.531	.788	139.3	504.2	139.3	39.4
.050	.569	.772	146.4	618.0	146.4	38.6

TABLE XLIII.—VALUES OF K FOR VARIOUS PROPORTIONS OF STEEL USED WHEN $C=750$, $s=75$, $f=20,000$.

$n=12$							$n=15$					
p	k	$1-\frac{2}{5}k$	K_c	K_s	K	S	k	$1-\frac{2}{5}k$	K_c	K_s	K	S
.001	.125	.950	57.2	19.0	19.0	71.2	.137	.945	64.7	18.9	18.9	70.9
.002	.173	.931	80.5	37.2	37.2	69.8	.161	.936	75.3	37.4	37.4	70.2
.003	.207	.917	94.5	55.0	55.0	68.8	.228	.909	103.6	54.5	54.5	68.2
.004	.235	.906	106.0	72.5	72.5	67.9	.258	.897	115.7	71.8	71.8	67.3
.005	.258	.897	115.7	89.7	89.7	67.3	.284	.886	125.8	88.6	88.6	66.4
.006	.279	.888	123.4	106.6	106.6	66.6	.308	.877	135.0	105.2	105.2	65.8
.007	.297	.881	130.4	123.3	123.3	66.1	.326	.870	141.8	121.8	121.8	65.2
.008	.314	.874	137.2	139.8	137.2	65.5	.342	.863	147.6	138.1	138.1	64.7
.009	.329	.868	142.4	156.2	142.4	65.1	.360	.856	154.1	154.1	154.1	64.2
.010	.344	.862	148.3	172.4	148.3	64.6	.375	.850	159.4	170.0	159.4	63.7
.012	.369	.852	156.8	204.5	156.8	63.9	.402	.839	168.7	201.4	168.7	62.9
.014	.392	.843	165.2	236.0	165.2	63.2	.425	.830	176.4	232.4	176.4	62.2
.016	.412	.835	172.0	267.2	172.0	62.6	.446	.822	183.3	253.0	183.3	61.6
.018	.430	.828	178.0	298.1	178.0	62.1	.465	.814	189.3	293.0	189.3	61.0
.020	.446	.822	183.3	328.8	183.3	61.6	.482	.807	194.5	322.8	194.5	60.5
.030	.513	.795	203.5	477.0	203.5	59.6	.551	.780	214.5	468.	214.5	58.5
.040	.562	.775	217.8	620.0	217.8	58.1	.600	.760	228.0	608.	228.0	57.0
.050	.599	.760	228.0	760.0	228.0	57.0	.638	.745	237.6	745.	237.6	55.8

Maximum Bending Moment in Slabs.—In Table XLIV, giving maximum bending moment in slabs according to straight line formula, the assumptions are:

$$C=500 \text{ lbs. per sq. in.}$$

$$n=12.$$

$$\text{Fireproofing}=1 \text{ in.}$$

$$M=Kbd^2 \text{ in thousands of in. lbs.}$$

TABLE XLIV.—MAXIMUM BENDING MOMENTS IN SLABS ACCORDING TO STRAIGHT LINE FORMULA.

Steel Sizes.		Slab Sizes in inches.							
Diameter in ins.	Spacing in ins.	3	3½	4	4½	5	5½	6	6½
1/4	6	2.8	3.6	4.3	5.2
	5	3.2	4.4	5.4	6.2
	4	3.4	5.0	6.2	7.3
5/16	6	3.4	5.0	6.3	7.4	9.0	9.7
	5	3.8	5.4	7.3	9.0	11.1	12.5
	4	4.0	5.8	8.0	10.2	12.4	14.7	16.9
	3	4.3	6.3	8.7	11.2	13.8	16.8	20.2
3/8	2½	4.6	6.8	9.2	11.9	14.9	18.0	21.2
	6	3.9	5.6	7.7	10.0	12.4	14.4	15.5	18.0
7/16	5	4.2	6.1	8.3	10.6	13.3	15.6	18.4	21.8
	4	4.4	6.5	8.8	11.4	14.1	17.3	20.7	24.4
	3	7.0	9.6	12.7	15.5	18.9	22.6	26.2
	2½	7.5	10.2	13.4	16.5	20.4	24.5	28.0
	6	6.3	8.6	10.9	13.7	16.9	20.0	23.1
1/2	5	6.7	9.1	11.9	14.8	18.0	21.2	24.6
	4	7.2	9.6	12.6	15.8	19.2	22.8	26.7
	3	7.7	10.6	13.7	17.2	21.0	25.1	29.5
	2½	14.7	18.4	22.4	26.8	31.7
5/8	6	15.0	18.1	21.7	25.4
	5	16.1	19.6	23.4	27.2
	4	17.1	21.0	25.0	29.0
	3	22.9	27.2	31.8
3/4	6	23.5	27.3
	5	25.5	30.5
7/8	4	26.8	31.7
	6	39.2
1	5	31.8
	4	33.3

The American Wire Fence Co., Chicago, who control the American system of reinforcing, have designed and executed a large number of buildings, basing their floor slab dimensions on Table XLV, in which the following assumptions are made:

- (1) One layer of 4x12-in. mesh high-carbon fabric of No. 5 carrying wires and No. 11 distributing wires.
- (2) High carbon steel rods in addition to the fabric where shown.
- (3) A 1 to 6 graded mixture of Portland cement, sand and pebbles or hard stone crushed to pass through a ¾-in. mesh screen, proportioned to give a maximum density (see page 21.)
- (4) All spans continuous in one direction.

Example.—For a 9-ft. span with a live load of 150 lbs. per sq. ft. over and above the dead load we require one layer of fabric and ¼-in. rods spaced 6¼ ins. on centers in a 4-in. slab.

TABLE XLV.—TABLE SHOWING THICKNESS AND REINFORCEMENT OF FLOOR SLABS FOR VARIOUS SPANS AND LOADS.

Live load in Lbs. per sq.ft.	Span in feet.														
	6	7	8	9	10	11	12	13	14	15	16	17	18	19	20
50	3 fabric	3 fabric	3 fabric	3 fabric	3 1-18	3½ 1-11	4 1-16½	4½ 1-12	4½ 1-10½	5 1-9	5½ 1-7½	5½ 1-10½	6 1-9	6½ 1-9	7 1-7½
75	3 fabric	3 fabric	3 fabric	3 1-18	3½ 1-9½	4 1-6½	4½ 1-5½	4½ 1-9½	5 1-8	5½ 1-6½	6 1-5½	6½ 1-9	7 1-8	7½ 1-7½	8 1-6½
100	3 fabric	3 fabric	3 1-18	3½ 1-10½	4 1-6	4½ 1-11½	5 1-9½	5½ 1-7½	6 1-11½	6½ 1-9½	7 1-8½	7½ 1-7½	8 1-6½	8½ 1-6½	9 1-5½
125	3 fabric	3 1-24	3½ 1-12	3½ 1-7½	4 1-5½	4½ 1-9½	5 1-8	5½ 1-6½	6 1-10½	6½ 1-9	7 1-8½	7½ 1-7	8 1-6½	8½ 1-5½	9 1-5½
150	3 fabric	3 1-17	3½ 1-9	4 1-6½	4½ 1-4½	5 1-8½	5½ 1-6½	6 1-5½	6½ 1-9	7 1-8	7½ 1-7	8 1-6½	8½ 1-5½	9 1-5½	9½ 1-7½
175	3 1-24	3½ 1-12	4 1-7½	4½ 1-11	5 1-9	5½ 1-7½	6 1-6½	6½ 1-5½	7 1-8½	7½ 1-7½	8 1-6½	8½ 1-5	9 1-8½	9½ 1-7½	10 1-7
200	3 1-21	3½ 1-9½	4 1-6½	4½ 1-10½	5 1-8	5½ 1-6½	6 1-5½	6½ 1-8½	7 1-7½	7½ 1-6½	8 1-6	8½ 1-5½	9 1-8	9½ 1-7½	10½ 1-6½
250	3½ 1-12½	4 1-7	4½ 1-5	5 1-8½	5½ 1-6½	6 1-10	6½ 1-8½	7 1-7½	7½ 1-7	8 1-6	8½ 1-8½	9 1-7½	9½ 1-7	10 1-6½	11 1-5½
300	4 1-9	4½ 1-5½	5 1-9½	5½ 1-7½	6 1-6	6½ 1-5	7 1-7½	7½ 1-6½	8½ 1-6	9 1-5½	9½ 1-7½	10 1-7	11 1-6½	11½ 1-5½	12 1-8

BEAMS AND GIRDERS.

Whenever a slab floor construction becomes too heavy owing to large span and load, beams are introduced and in most cases built monolithic with the floor slabs, so that for calculation purposes the beams may be considered as tee-beams. The area above the neutral axis is then relied upon to take care of the compressive stresses, while the tension is taken up by the steel reinforcement placed below the neutral axis in the web. There is as great a number of beam systems as floor slab systems, and before entering upon the calculation of typical floors and beams a number of the better known systems will be described. Beams are classed as loose rod systems or frame systems.

Loose Rod Systems.—Loose rods for reinforcing beams were formerly employed exclusively, but more recent practice has shown the advisability of tying the reinforcing members rigidly together before placing them in the mold. This latter method is used very extensively in American practice, while the loose rod method is preferred abroad. This difference between American and foreign practice is traceable directly to the difference in conditions governing the work. In America, where labor is higher, rapidity in erection becomes an important feature, and the time cannot be spent in the field for careful placing of reinforcement, hence the utility of having the reinforcement arrive in the field in an assembled state. The following are some of the more important loose rod systems:

The Hennebique system uses two round rods with split ends, one rod being straight and the other bent upward at a point about one-third of the span from the supports for the purpose of resisting the shearing stresses at the ends.



Another feature is the use of hoop iron stirrups (Fig. 58) at intervals to strengthen the beam against horizontal shear or diagonal tension. Both bars are included within the same

Fig. 58. — Stirrup stirrup, but in some forms of construction the bent and straight bars are used alternately.
Used in Hennebique System.

For heavy construction, compression reinforcement is also resorted to, and in this case stirrups are placed outside of these rods and extend downward into the concrete.

The *Coularou system*, Fig. 59, has stirrups inclined at 45° and their spacing increases from the supports toward the middle of the span. Each stirrup is hooked around upper and lower reinforcement, and near the middle of the beam



Fig. 59.—Coularou Beam Reinforcement.

the upper reinforcement is bent down at an angle of 45° and joins the lower bar, parallel to the same over the central portion of the beam.

The *Locher beam* consists of a number of round or flat bars of different length, having their middle portion straight and being curved up at the ends, with the intention of being as nearly as possible normal to the direction of the maximum tensile stresses, thereby decreasing the tendency toward sliding or slipping along the length of the reinforcement.

The *Coignet system*, Fig. 60, has upper and lower bars connected by a light hoop iron web fastened alternately to the upper and lower bars, thus forming a light truss.

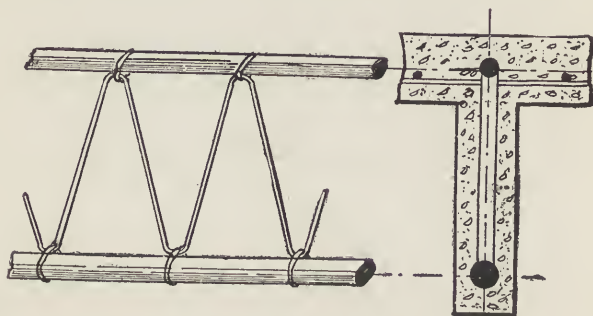

Fig. 60.—Coignet Beam Reinforcement.

Frame Systems.—Various styles of reinforcement for frame systems are illustrated by Figs. 20 to 25. In addition to having the beam and girder reinforcement tied rigidly together, it is customary with most of these systems, to tie the columns and slabs reinforcement to that in the beams and girders, thus having all the steel reinforcement in the building tied together. As much as possible of the fastening together is done before insertion in the forms, thus reducing to a minimum the liability of wrongly placing the steel.

Tables of Safe Loads and Steel Area for Beams.—From formulas evolved by Prof. Talbot, given on p. 94, from Univ. of Ill. Bulletin, Feb. 1, 1907, the following rules are deduced:

(1) For area of cross-section of steel reinforcement for other widths of beam multiply by the width in inches.

(2) Total loads for other spans and the same depth of steel are inversely proportional to the spans.

(3) Total loads for other depths of steel and the same span are directly proportional to the squares of the depths.

By using the above mentioned formulas, Tables XLVI to LI, similar to those given in Concrete, Plain and Reinforced, by Taylor and Thompson, have been calculated, using different values for K , p , C and f .

The following formulas are a guide to determine or check p and K :

$$p = \frac{1}{2 \frac{f}{C} \left(1 + \frac{f}{Cn}\right)} \quad \text{and} \quad K = \frac{C}{2} \left(\frac{1}{1 + \frac{f}{Cn}} \right) \left(1 - \frac{1}{3 \left(1 + \frac{f}{Cn}\right)} \right)$$

Some writers prefer to use ultimate loads and ultimate moments. Considerable economy in construction is often found by using $4LL + 2DL$, where $LL =$ live load, and $DL =$ dead load.

For instance, for a roof

$$4 \times 40 = 160 \text{ lbs. per sq. ft. LL}$$

$$2 \times 50 = 100 \text{ lbs. per sq. ft. DL}$$

$$\text{Total. } \overline{260} \text{ lbs. per sq. ft.}$$

Then the elastic limits of steel and concrete are used instead of the values given for f and C .

TABLE XLVI.—SAFE LOADS AND STEEL AREAS FOR BEAMS.

Depth of Beam <i>h</i> ins.	Safe load in lbs. per linear ft. of beam.											
	Span in feet.											
	5	6	7	8	9	10	11	12	13	14	15	16
5	44	30	22	17	13	11	9	8
6	68	47	35	27	21	17	15	12	10	9
7	98	68	50	38	30	25	20	17	15	13	11	10
8	134	93	68	52	41	33	28	23	20	17	15	13
9	164	114	84	64	51	41	34	28	24	21	19	16
10	209	145	106	82	64	52	43	36	31	27	23	20
11	259	180	132	101	80	65	54	45	38	33	29	25
12	315	219	161	123	97	79	65	55	47	40	35	31
13	360	250	184	141	111	90	74	63	53	46	40	35
14	426	296	217	166	131	106	88	74	63	54	47	42
15	497	345	253	194	153	124	103	86	73	63	55	48
16	573	398	292	224	177	143	118	99	85	73	64	56
17	655	455	334	256	202	164	135	114	97	84	73	64
18	742	515	379	290	229	185	153	129	110	95	82	72
19	788	547	402	308	243	197	163	137	116	100	88	77
20	613	451	345	272	221	182	153	131	113	98	86
22	757	556	426	336	273	225	189	161	139	121	106
24	673	515	407	330	272	229	195	168	147	129
26	613	484	392	324	272	232	200	174	153
28	720	569	461	381	320	272	235	205	180
30	660	534	441	371	316	273	237	209
36	765	632	531	452	390	340	300
42	738	629	542	472	415	360
48	720	627	551	480

Proportions, 1:6 steel reinforcement, 0.8 per cent; $K = 102.2$; $E = 3,000,000$.
 h = depth of beam; $n = 10$; $C = 700$; $f = 14,000$; $b = 1$; d = depth of steel from top of beam.

TABLE XLVI. (Continued).—SAFE LOADS AND STEEL AREAS FOR BEAMS.

Safe load in lbs., per linear ft. of beam.							Wt. of beam, 1 in. wide, per lin. ft.	Depth to steel.	Depth below steel.	Steel area for 1 in. width of beam.	Safe moment of resistance.	Depth of beam.
Span in ft.												
17	18	19	20	25	30	35	lbs.	d ins.	ins.	sq. ins.	M	h ins.
.....	5.3	4.0	1.0	.032	1,635	5
.....	6.3	5.0	1.0	.040	2,555	6
.....	7.4	6.0	1.0	.048	3,679	7
12	8.5	7.0	1.0	.056	5,006	8
14	9.5	7.75	1.25	.062	6,138	9
18	16	14	13	10.6	8.75	1.25	.070	7,825	10
22	20	18	16	11.6	9.75	1.25	.078	9,715	11
27	24	22	20	12.7	10.75	1.25	.086	11,810	12
31	28	25	23	13.8	11.5	1.5	.092	13,516	13
37	33	29	27	14.8	12.5	1.5	.10	15,969	14
43	38	34	31	20	15.9	13.5	1.5	.108	18,626	15
50	44	40	36	23	16.9	14.5	1.5	.116	21,487	16
57	51	45	41	26	18.0	15.5	1.5	.124	24,543	17
64	57	51	46	30	21	19.1	16.5	1.5	.132	27,824	18
68	61	55	49	31	22	20.1	17.0	2.0	.136	29,536	19
76	68	61	55	35	25	21.2	18.0	2.0	.144	33,113	20
94	84	75	68	44	30	22	23.3	20.0	2.0	.160	40,880	22
114	102	91	82	53	37	27	25.4	22.0	2.0	.176	49,465	24
136	121	109	98	63	44	32	27.6	24.0	2.0	.192	58,867	26
159	142	128	115	74	51	38	29.7	26.0	2.0	.208	69,087	28
185	165	148	133	85	59	44	31.8	28.0	2.0	.224	80,125	30
264	236	212	191	122	85	62	38.1	33.5	2.5	.268	114,694	36
368	328	294	266	170	118	87	44.5	39.5	2.5	.316	159,457	42
488	435	391	353	220	157	115	50.9	45.5	2.5	.364	211,579	48

$$M = \frac{wl^2 \times 12}{8} = Kbd^2.$$

TABLE XLVII.—SAFE LOADS AND STEEL AREAS FOR BEAMS.

Depth of beam. <i>h</i> ins.	Safe load in lbs. per linear ft. of beam.											
	Span in feet.											
<i>h</i> ins.	5	6	7	8	9	10	11	12	13	14	15	16
5	37	26	19	14	11	9	8
6	58	40	29	22	18	14	12	10	9
7	83	58	42	32	26	21	17	14	12	11	9
8	113	79	58	43	35	28	23	20	17	14	13	11
9	139	97	71	54	43	35	29	24	20	18	15	14
10	177	123	91	69	54	44	37	31	26	23	20	17
11	220	153	112	86	68	55	45	38	32	28	24	21
12	267	186	136	104	82	67	55	46	39	34	30	26
13	305	212	156	119	94	76	63	53	45	39	34	30
14	361	255	184	141	111	90	74	63	53	46	40	35
15	421	292	214	165	130	105	87	73	62	54	47	41
16	485	338	248	189	150	121	100	84	72	62	54	47
17	555	385	284	216	171	139	115	96	82	71	62	54
18	630	437	321	246	194	157	130	109	93	80	70	61
19	667	465	341	261	206	167	138	116	99	85	74	65
20	748	521	382	293	231	187	155	130	111	95	83	73
22	924	644	472	361	285	231	191	161	137	118	103	90
24	1119	780	571	437	345	280	231	194	166	143	125	110
26	1330	927	680	520	410	332	275	230	197	170	148	130
28	1560	1083	797	610	481	390	322	271	231	199	174	153
30	1810	1260	925	708	558	454	374	314	268	231	202	177
36	2586	1808	1322	1010	800	648	532	450	384	331	288	254
42	3600	2516	1840	1410	1114	903	745	626	534	460	401	353
48	4782	3340	2442	1869	1475	1192	988	830	708	610	532	468

Proportions, 1:6; steel reinforcement, 0.4 per cent; $K=74$; $E=3,000,000$;
 h =depth of beam; $n=7.5$; $C=750$; $f=20,000$; $b=1$; d =depth of steel from
top of beam.

TABLE XLVII. (Continued).—SAFE LOADS AND STEEL AREAS FOR BEAMS.

Span in feet.							Wt. of beam, 1 in. wide, per lin. ft.	Depth to steel.	Depth below steel.	Steel area for 1 in. width of beam.	Safe moment of resistance.	Depth of beam.
17	18	19	20	25	30	35						
Safe load in lbs. per linear ft. of beam.							lbs.	d ins.	ins.	sq. ins.	M	h ins.
							5.3	4	1.	.016	1,392	5
							6.3	5.	1.	.020	2,175	6
7							7.3	6.	1.	.024	3,132	7
10	9	7.8	7				8.4	7.	1.	.028	4,263	8
12	11	9.6	9				9.4	7.75	1.25	.031	5,225	9
							10.5	8.75	1.25	.035	6,661	10
15	14	12.2	11	7			11.5	9.75	1.25	.039	8,270	11
19	17	15.2	14	10	6	4.5	12.6	10.75	1.25	.043	10,054	12
23	21	18.5	17	11	7	5.4	13.7	11.5	1.5	.046	11,506	13
26	23	21.2	19	12	8	6.2	14.7	12.5	1.5	.05	13,594	14
31	28	25	23	14	10	7.3						
							15.8	13.5	1.5	.054	15,856	15
36	32	29	26	17	12	8.6	16.8	14.5	1.5	.058	18,292	16
42	37	33.6	30	19	13	9.9	17.9	15.5	1.5	.062	20,903	17
48	43	38.4	35	22	15	11.3	18.9	16.5	1.5	.066	23,686	18
54	48	43.5	39	25	17	12.8	20.0	17	2	.068	25,143	19
58	51	46.2	42	27	19	13.6						
							21.0	18	2	.072	28,188	20
65	57	51.9	47	30	20.8	15.2	23.1	20	2	.080	34,800	22
80	71	64	58	37	25.7	18.8	25.2	22	2	.088	42,108	24
97	86	77.5	70	45	31.1	22.8	27.3	24	2	.096	50,012	26
115	100	92.1	83	53	37	27	29.4	26	2	.104	55,712	28
135	120	108	98	62	43.5	31.8						
							31.5	28	2	.112	68,208	30
157	140	125	114	72	50.4	37	37.8	33.5	2.5	.134	106,357	36
224	200	180	163	103	72.2	52.8	44.1	39.5	2.5	.158	135,742	42
312	278	250	226	144	100	73.4	50.4	45.5	2.5	.182	180,112	48
414	368	331	300	191	133	97.2						

$$M = \frac{wl^2 \times 12}{8} = Kbd^2.$$

TABLE XLVIII.—SAFE LOADS AND STEEL AREAS FOR BEAMS.

Depth of beam <i>h</i> ins.	Safe load in lbs. per linear ft. of beam.											
	Span in feet.											
	5	6	7	8	9	10	11	12	13	14	15	16
5	32	22	16	12	10	8
6	49	34	25	19	15	12	10	9
7	71	50	36	28	22	18	15	12	10	9	8
8	97	67	49	38	30	24	20	17	14	12	11	9
9	119	82	61	46	37	30	25	21	17	15	13	11
10	151	105	77	59	42	38	31	26	22	19	17	15
11	188	131	97	73	58	47	39	33	28	24	21	18
12	228	158	117	89	70	56	47	40	34	29	25	22
13	262	181	134	102	80	65	54	42	39	33	29	25
14	309	214	158	120	95	77	64	53	45	39	34	30
15	360	250	184	140	111	90	75	62	53	46	40	35
16	415	288	212	162	128	103	86	72	61	53	46	40
17	475	331	243	185	146	119	99	82	70	60	53	46
18	542	378	275	216	167	135	112	94	80	69	60	52
19	573	396	291	222	176	143	116	99	84	73	63	55
20	642	445	327	250	198	160	133	111	94	81	71	62
22	792	550	404	308	244	197	164	137	117	101	88	77
24	956	665	489	372	295	248	198	166	142	124	106	93
26	1138	793	582	443	352	284	236	197	168	145	127	111
28	1336	925	683	520	412	333	276	232	197	170	148	130
30	1550	1078	792	605	478	386	320	269	229	197	172	151
36	2220	1540	1134	865	685	553	459	385	328	282	246	217
42	3085	2140	1576	1204	952	770	638	535	455	393	344	299
48	4090	2838	2090	1595	1264	1020	845	710	605	521	455	396

Proportions, 1:6; steel reinforcement, 0.6 per cent; $K=87$; $E=3,000,000$;
 h =depth of beam; $n=10$; $C=750$; $f=16,000$; $b=1$; d =depth of steel from
top of beam.

TABLE XLVIII. (Continued).—SAFE LOADS AND STEEL AREAS FOR BEAMS.

Span in feet.							Safe load in lbs. per linear ft. of beam.	Wt. of beam, 1 in. wide, per in. ft.	Depth to steel.	Depth below steel.	Steel area for 1 in. width of beam.	Safe moment of resistance.	Depth of beam.
17	18	19	20	25	30	35	lbs.	<i>d</i> ins.	ins.	sq. ins.	<i>M</i>	<i>h</i> ins.	
.....	5.3	4	1	.024	1,184	5	
.....	6.3	5	1	.030	1,850	6	
.....	7.4	6	1	.036	2,664	7	
8	7	8.4	7	1	.042	3,626	8	
10	9	8	9.4	7.75	1.25	.0465	4,445	9	
13	12	10	9	6	10.5	8.75	1.25	.0525	5,666	10	
16	14	13	12	7	11.6	9.75	1.25	.0585	7,035	11	
20	18	16	14	9	6	12.7	10.75	1.25	.0645	8,551	12	
22	20	18	16	10	7	13.7	11.5	1.5	.069	9,787	13	
27	24	21	19	13	9	14.7	12.5	1.5	.075	11,563	14	
31	28	25	23	14	10	7	15.8	13.5	1.5	.081	13,480	15	
36	32	29	26	16	11	8	16.8	14.5	1.5	.087	15,558	16	
41	37	33	30	19	13	10	17.9	15.5	1.5	.093	17,778	17	
47	41	37	34	21	15	11	19.0	16.5	1.5	.099	20,140	18	
49	44	40	36	23	16	12	19.9	17	2	.102	21,386	19	
55	49	44	40	26	18	13	21.1	18	2	.108	23,976	20	
68	61	55	50	32	22	16	23.2	20	2	.120	29,600	22	
82	74	66	60	38	27	20	25.3	22	2	.132	35,816	24	
98	88	79	71	45	32	23	27.4	24	2	.144	42,624	26	
115	103	92	84	53	37	27	29.5	26	2	.156	50,024	28	
136	120	107	97	62	43	32	31.6	28	2	.168	58,016	30	
191	172	154	139	89	62	45	38.0	33.5	2.5	.201	83,079	36	
265	249	214	194	123	86	63	43.3	39.5	2.5	.237	115,458	42	
352	317	284	258	163	114	84	50.6	45.5	2.5	.273	153,198	48	

$$M = \frac{wl^2 \times 12}{8} = Kbd^2.$$

TABLE XLIX—SAFE LOADS AND STEEL AREAS FOR BEAMS.

Depth of beam. <i>h</i> ins.	Safe load in lbs. per linear ft. of beam.											
	Span in feet.											
	5	6	7	8	9	10	11	12	13	14	15	16
5	55	38	28	21	16	14	11	10
6	85	59	44	34	26	21	19	15	13	11
7	123	85	63	48	38	31	25	21	19	16	14	13
8	168	116	85	65	51	41	35	29	25	21	19	16
9	205	143	105	80	64	51	43	35	30	26	24	20
10	261	181	133	103	80	65	54	45	39	34	29	25
11	324	225	165	126	100	81	68	56	48	41	36	31
12	394	274	201	154	121	99	81	69	59	50	44	39
13	450	313	230	176	139	113	93	79	66	58	50	44
14	533	370	271	208	164	133	110	93	79	68	59	53
15	621	431	316	243	191	155	129	108	91	79	69	60
16	716	498	365	280	221	179	148	124	106	91	80	70
17	819	569	418	320	253	205	169	143	121	105	91	80
18	928	644	474	363	286	231	191	161	138	119	103	90
19	985	684	503	385	304	246	204	171	145	125	110	96
20	766	564	431	340	276	228	191	164	141	123	108
22	946	695	533	420	341	281	236	201	174	151	133
24	841	644	509	413	340	286	244	210	184	161
26	766	605	490	405	340	290	250	218	191
28	900	711	576	476	400	340	294	256	225
30	825	668	551	464	395	341	296	261
36	956	790	664	565	488	425	375
42	923	786	678	590	519
48	900	784	689

Proportions, 1:6; steel reinforcement, 0.8 per cent; $K=102.2$; $E=3,000,000$; h =depth of beam; $n=10$; $C=700$; $f=14,000$; $b=1$; d =depth of steel from top of beam.

TABLE XLIX. (Continued).—SAFE LOADS AND STEEL AREAS FOR BEAMS.

Safe load in lbs. per linear ft. of beam.							Wt. of beam, 1 in. wide, per lin. ft.	Depth to steel.	Depth below steel.	Steel area for 1 in. width of beam.	Safe moment of resistance.	Depth of beam.
Span in ft.												
17	18	19	20	25	30	35	lbs.	<i>d</i> ins.	ins.	sq. ins.	<i>M</i>	<i>h</i> ins.
.....	5.3	4.	1.	.032	1,635	5
.....	6.3	5.	1.	.040	2,555	6
.....	7.4	6.	1.	.048	3,679	7
15	8.5	7.	1.	.056	5,008	8
18	9.5	7.75	1.25	.062	6,138	9
23	20	18	16	10.6	8.75	1.25	.070	7,825	10
28	25	23	20	11.6	9.75	1.25	.078	9,715	11
34	30	28	25	12.7	10.75	1.25	.086	11,811	12
39	35	31	29	13.8	11.5	1.5	.092	13,516	13
46	41	36	34	14.8	12.5	1.5	.10	15,969	14
54	48	43	39	25	15.9	13.5	1.5	.108	18,626	15
63	55	50	45	29	16.9	14.5	1.5	.116	21,487	16
71	64	56	51	33	18.0	15.5	1.5	.124	24,543	17
80	71	64	58	38	26	19.1	16.5	1.5	.132	27,824	18
85	76	69	61	39	28	20.1	17.	2.	.136	29,536	19
95	85	76	69	44	31	21.2	18.	2.	.144	33,113	20
118	105	94	85	55	38	28	23.3	20.	2.	.160	40,880	22
143	128	113	103	66	46	34	25.4	22.	2.	.176	49,465	24
170	151	136	123	79	55	40	27.6	24.	2.	.192	58,867	26
199	178	160	144	93	64	48	29.7	26.	2.	.208	69,087	28
231	206	185	166	106	74	55	31.8	28.	2.	.224	80,125	30
330	295	265	239	153	106	78	38.1	33.5	2.5	.268	114,694	36
460	410	368	333	213	148	109	44.5	39.5	2.5	.316	159,458	42
610	544	489	441	275	196	144	50.9	45.5	2.5	.364	211,579	48

$$M = \frac{wl^2 \times 12}{10} = Kbd^3.$$

TABLE L.—SAFE LOAD PER SQUARE FOOT AND STEEL AREA FOR SLABS, CONTINUOUS AT ENDS ONLY.

Thickness. <i>h</i> ins.	Safe load per sq. ft., including wt. of slab.								
	Span in feet.								
	4	5	6	7	8	9	10	11	
$p = 0.004; C = 460.$									
3	160	102	71	52	40	32	26	21	
3½	239	153	106	78	60	47	38	32	
4	334	214	148	109	83	66	53	44	
4½	387	248	172	126	97	77	62	51	
5	506	324	225	165	127	100	81	67	
6	791	506	351	258	198	156	126	105	
7	1138	729	506	372	285	225	182	151	
8	1549	992	689	506	387	306	248	205	
$p = 0.006; C = 580.$									
3	235	150	104	77	59	46	38	31	
3½	351	225	156	115	88	69	56	46	
4	491	314	218	160	123	97	78	65	
4½	569	364	253	186	142	112	91	75	
5	743	476	330	243	186	147	119	99	
6	1161	743	516	379	290	229	186	154	
7	1672	1070	743	546	418	330	268	221	
8	2276	1456	1011	743	569	449	384	301	
$p = 0.008; C = 680.$									
3	309	198	137	101	77	61	49	41	
3½	461	299	205	151	115	91	74	61	
4	645	412	286	210	161	127	103	85	
4½	747	478	332	244	187	148	120	98	
5	976	625	434	319	244	193	156	129	
6	1525	976	677	498	381	301	244	202	
7	2196	1405	976	717	549	434	351	290	
8	2989	1913	1328	976	747	590	478	395	
$p = 0.010; C = 700.$									
3	381	244	169	124	95	75	61	50	
3½	569	364	253	186	142	112	91	75	
4	795	509	353	260	198	157	127	105	
4½	922	590	410	303	230	182	147	122	
5	1204	771	535	393	301	238	193	160	
6	1881	1204	836	614	470	372	301	248	
7	2709	1734	1204	884	677	535	433	359	
8	3687	2360	1639	1204	922	728	590	488	
$p = 0.012; C = 700.$									
3	421	269	187	137	105	83	67	56	
3½	629	402	279	205	157	124	101	83	
4	878	562	390	287	219	174	140	116	
4½	1018	652	453	332	255	201	163	135	
5	1330	851	591	434	333	263	213	176	
6	2078	1330	924	678	520	410	332	275	
7	2993	1915	1330	977	748	591	479	396	
8	4073	2607	1810	1330	1018	805	652	538	

$$n = 15; M = \frac{wl^2 \times 12}{10} = Kbd^2.$$

TABLE L. (Continued).—SAFE LOAD PER SQUARE FOOT AND STEEL AREA FOR SLABS, CONTINUOUS AT ENDS ONLY.

Safe load per sq. ft., including wt. of slab.				Wt. of slab, per sq. ft.	Depth to steel.	Depth below steel.	Steel area per 1 ft. width of slab.	Safe moment of resistance.	Thickness.	
Span in feet.										
12	13	14	15	lbs.	d ins.	ins.	sq. ins.	in. lbs.	h ins.	
$p=0.004; C=460.$										
18	15	13	11	37.8	2½	¾	.108	3,070	3	
27	23	19	17	44.2	2¾	¾	.132	4,500	3½	
37	32	27	24	50.4	3½	¾	.156	6,410	4	
43	37	32	28	56.7	3½	1	.168	7,440	4½	
56	48	41	36	63.0	4	1	.192	9,720	5	
88	75	65	56	75.6	5	1	.240	15,180	6	
121	108	93	81	88.2	6	1	.288	21,860	7	
172	147	122	110	100.8	7	1	.336	29,750	8	
$p=0.006; C=580.$										
26	22	19	17	37.9	2½	¾	.162	4,510	3	
39	33	29	25	44.3	2¾	¾	.192	6,740	3½	
55	46	40	35	50.5	3½	¾	.234	9,420	4	
63	54	46	40	56.8	3½	1	.252	10,920	4½	
83	70	61	53	63.2	4	1	.288	14,270	5	
129	110	95	83	75.8	5	1	.360	22,290	6	
186	158	136	119	88.6	6	1	.432	32,100	7	
253	215	186	162	101.2	7	1	.504	43,690	8	
$p=0.008; C=680.$										
34	29	25	22	38.0	2½	¾	.216	5,930	3	
51	44	38	33	44.4	2¾	¾	.264	8,860	3½	
72	61	53	46	50.7	3½	¾	.312	12,370	4	
83	71	61	53	57.0	3½	1	.336	14,350	4½	
108	92	80	69	63.4	4	1	.384	18,740	5	
170	144	125	108	76.1	5	1	.480	29,280	6	
244	208	179	156	88.9	6	1	.576	42,160	7	
332	283	244	213	101.6	7	1	.672	57,390	8	
$p=0.010; C=700.$										
42	36	31	27	38.1	2½	¾	.270	7,320	3	
63	54	46	40	44.5	2¾	¾	.330	10,930	3½	
88	75	65	57	50.9	3½	¾	.390	15,260	4	
102	87	75	66	57.2	3½	1	.420	17,700	4½	
134	114	98	86	63.6	4	1	.480	23,120	5	
209	178	154	134	76.4	5	1	.600	36,120	6	
301	256	221	193	89.2	6	1	.720	52,020	7	
410	349	301	262	102.0	7	1	.840	70,800	8	
$p=0.012; C=700.$										
47	40	34	30	38.3	2½	¾	.324	8,080	3	
70	60	51	45	44.6	2¾	¾	.396	12,070	3½	
98	83	72	62	51.1	3½	¾	.468	16,860	4	
113	96	83	72	57.3	3½	1	.504	19,500	4½	
148	126	109	95	63.9	4	1	.576	25,540	5	
231	197	170	148	76.7	5	1	.720	39,900	6	
333	283	244	213	89.5	6	1	.864	57,460	7	
453	386	332	290	102.4	7	1	1.008	78,200	8	

$$n=15; M = \frac{wl^2 \times 12}{10} = Kbd^2.$$

TABLE LI.—SAFE LOAD PER SQUARE FOOT AND STEEL AREA FOR SLABS, EITHER CONTINUOUS OR FIXED AT THE FOUR EDGES.

Thickness, h ins.	Safe load per sq. ft., including wt. of slab.							
	Span in feet.							
	4	5	6	7	8	9	10	11
$p=0.004; C=460.$								
3	320	205	142	105	80	63	51	42
3½	478	306	213	156	120	94	76	63
4	668	428	297	218	167	132	107	88
4½	775	496	344	253	194	153	124	102
5	1012	648	450	330	253	200	162	134
6	1581	1012	703	516	395	312	253	209
7	2277	1457	1012	744	569	450	364	301
8	3099	1984	1377	1012	775	612	496	410
$p=0.006; C=580.$								
3	470	301	209	154	118	93	75	62
3½	702	450	312	229	176	139	112	93
4	981	628	436	320	245	194	157	130
4½	1137	728	506	371	284	225	182	150
5	1486	951	660	485	372	294	238	197
6	2322	1486	1032	758	580	459	371	307
7	3343	2140	1486	1092	836	660	535	442
8	4551	2913	2023	1486	1138	899	728	602
$p=0.008; C=680.$								
3	617	396	274	202	154	122	99	82
3½	923	590	410	301	231	182	148	122
4	1288	825	573	421	322	254	206	170
4½	1494	956	664	488	374	295	239	198
5	1952	1249	868	637	488	386	312	258
6	3050	1952	1355	996	762	602	489	403
7	4392	2811	1952	1434	1098	867	703	581
8	5978	3826	2657	1952	1495	1181	956	790
$p=0.010; C=700.$								
3	762	488	339	249	190	151	122	101
3½	1138	729	506	372	285	225	182	151
4	1590	1018	707	519	397	314	254	210
4½	1844	1180	819	602	461	364	295	244
5	2408	1541	1070	786	602	476	385	318
6	3763	2408	1672	1229	941	743	602	498
7	5419	3468	2408	1769	1355	1070	867	717
8	7375	4720	3278	2408	1844	1457	1180	975
$p=0.012; C=700.$								
3	842	539	374	275	210	166	135	111
3½	1257	805	559	411	314	248	201	166
4	1756	1124	780	573	439	347	281	232
4½	2037	1303	905	665	509	402	326	269
5	2660	1702	1182	869	665	525	426	352
6	4156	2660	1847	1357	1039	821	665	550
7	5985	3830	2660	1954	1496	1182	958	791
8	8146	5214	3620	2660	2037	1609	1303	1077

$$n=15; M = \frac{wl^2}{20} \times 12 = Kbd^2.$$

BUILDING DESIGN AND CONSTRUCTION. 121

TABLE LI. (Continued).—SAFE LOAD PER SQUARE FOOT AND STEEL AREA FOR SLABS, EITHER CONTINUOUS OR FIXED AT THE FOUR EDGES.

Safe load per sq. ft., including wt. of slab.				Wt. of slab, per sq. ft.	Depth to steel.	Depth below steel.	Steel area for 1 in. width of beam.	Safe moment of resistance.	Thickness.	
Span in feet.										
12	13	14	15	lbs.	d ins.	ins.	sq. ins.	in. lbs.	h ins.	
$p=0.004; C=460.$										
36	30	26	23	37.8	2½	¾	.108	3,070	3	
53	45	39	34	44.2	2¾	¾	.132	4,590	3½	
74	63	54	48	50.4	3¼	¾	.156	6,410	4	
86	73	63	55	56.7	3½	1	.168	7,440	4½	
112	96	83	72	63.0	4	1	.192	9,720	5	
176	150	129	112	75.6	5	1	.240	15,180	6	
253	216	186	162	88.2	6	1	.288	21,860	7	
344	293	253	220	100.8	7	1	.336	29,750	8	
$p=0.006; C=580.$										
52	45	38	33	37.9	2½	¾	.162	4,510	3	
78	66	57	50	44.3	2¾	¾	.192	6,740	3½	
109	93	80	70	50.5	3¼	¾	.234	9,420	4	
126	108	93	81	56.8	3½	1	.252	10,920	4½	
165	141	121	106	63.2	4	1	.288	14,270	5	
258	220	190	165	75.8	5	1	.360	22,290	6	
372	316	273	238	88.6	6	1	.432	32,100	7	
506	431	371	324	101.2	7	1	.504	43,660	8	
$p=0.008; C=680.$										
69	58	50	44	38.0	2½	¾	.216	5,930	3	
103	87	75	66	44.4	2¾	¾	.264	8,860	3½	
143	122	105	92	50.7	3¼	¾	.312	12,370	4	
166	141	122	106	57.0	3½	1	.336	14,350	4½	
217	185	159	139	63.4	4	1	.384	18,740	5	
339	288	249	217	76.1	5	1	.480	29,280	6	
488	416	359	312	88.9	6	1	.576	42,160	7	
664	566	488	425	101.6	7	1	.672	57,390	8	
$p=0.010; C=700.$										
85	72	62	54	38.1	2½	¾	.270	7,320	3	
126	107	93	81	44.5	2¾	¾	.330	10,930	3½	
177	151	130	113	50.9	3¼	¾	.390	15,260	4	
205	175	151	131	57.2	3½	1	.420	17,700	4½	
268	228	196	171	63.6	4	1	.480	23,120	5	
418	356	307	268	76.4	5	1	.600	36,120	6	
602	513	442	385	89.2	6	1	.720	52,020	7	
820	698	602	524	102.0	7	1	.840	70,800	8	
$p=0.012; C=700.$										
94	80	69	60	38.3	2½	¾	.324	8,080	3	
140	119	103	90	44.6	2¾	¾	.396	12,070	3½	
195	166	143	125	51.1	3¼	¾	.468	16,860	4	
226	193	166	145	57.3	3½	1	.504	19,550	4½	
295	252	217	190	63.9	4	1	.576	25,540	5	
462	393	339	296	76.7	5	1	.720	39,900	6	
665	565	489	426	89.5	6	1	.864	57,460	7	
905	771	665	580	102.4	7	1	1.008	78,200	8	

$$n=15; M = \frac{wl^2 \times 12}{20} = Kbd^2.$$

COLUMNS.

Classification of Columns.—There are several kinds of reinforced concrete columns in use to date:

(1) Rectangular or polygonal columns, reinforced with straight rods, tied together at intervals with plates, rods or bands.

(2) Hooped columns with spiral continuous reinforcement encircling the column at close intervals and containing additional vertical rods, invented by Considere.

(3) Hooped columns with annular rings of round or band iron also kept spaced by vertical reinforcement, as in the Cummings system.

(4) Expanded metal hooped columns, where expanded metal lathing incloses and restrains the concrete.

(5) Structural steel or cast iron columns filled with concrete.

Rectangular or Polygonal Columns.—In rectangular or polygonal columns four or more vertical rods are tied together horizontally by wires or plates placed at a distance apart very nearly the maximum horizontal dimension of the column, each band being firmly fastened by wire or otherwise to the vertical rods. This construction was used in the Winton Garage in Chicago, designed by the author in 1903. At the bottom of the columns the rods rest on a 24x24x $\frac{1}{2}$ -in. steel plate bedded in the concrete footing. The joints occur 6 ins. above each floor level and are made with a sleeve of gas pipe, into which the ends of the two sections of rods are wedged. A 1-2-2 mixture was used for this construction and the following shows the method of calculation employed:

Size of column 20 ins. \times 20 ins. = 400 sq. ins.

Four rods, $2\frac{3}{8}$ ins. in diameter = $5.1572 \times 4 = 20.6288$ sq. ins.

P = load on column.

C = safe stress on concrete in lbs. per sq. in.

A = area of concrete in sq. ins.

n = ratio between modulus of elasticity of steel and concrete.

a = area of vertical steel.

$$P = C \{ A + a (n - 1) \} = 600 \{ 400 + 20.63 (10 - 1) \} = 351,400 \text{ lbs.} = 175.7 \text{ tons.}$$

It will be noticed that C was assumed at 600 lbs. per sq. in. and n at 10.

A similar construction was used in the Ingalls building in Cincinnati, 16 stories high, and here the wind pressure was taken care of by additional twisted rods running up parallel to the carrying rods.

For factory buildings the columns carrying traveling cranes are exposed to eccentric loads and must be calculated accordingly. Besides, the crane-carrying brackets must be carefully tied to the column. A good construction for this purpose is that employed in the screen house of Ontario Power Co. of Niagara Falls, Ontario. The columns are 12x15 ins. in section and support the direct load of heavy roof beams and an eccentric load from a 20x60-in. reinforced concrete girder, resting upon brackets in the inner side of the columns. The column reinforcement consists of four rods $1\frac{1}{4}$ ins. in diameter fastened together by ties in the usual manner. The brackets extend 15 ins. from the columns to which they are fastened and are 12 ins. wide. Wall columns of this style are usually rectangular or tee form, or even of hollow sections.

Hooped Columns.—Hooped columns to be effective should have the hoops in circular form, either as a helix or as a series of annular hoops, such as is used in the Cummings, American or Monolith systems, Figs. 26 to 29. In Tables LII to LVII the requirements of New York City and Brooklyn are practically covered and the tables are safe, as may be readily seen by comparisons with ultimate loads according to the empirical formula

of Considere as tabulated in Table LVIII, "Hooped Columns, Considere's Formula."

Where the load to be carried is moderate, so that longitudinal reinforcement is not required to assist in carrying it, a very efficient form of hooping can be made by rolling sheets of expanded metal into cylinders, causing all adjacent edges to overlap so as to interlock the meshes. If securely wired, the cylinder thus composed of a right and a left spiral of intersecting strands, will act not only as a hooping, but also as longitudinal reinforcement to resist flexure.

Design of Hooped Columns.—To reduce the area of floor columns and accordingly increase available floor space has been one of the most important problems in reinforced concrete building construction. Owing, however, to the unfinished state of actual tests and the uncertainty of the value of both empirical formulas and the application of the elastic theory to a composite body, the calculation of columns both for direct and eccentric loads is quite intricate, and we will here merely give such methods as have been accepted in the principal municipalities in the United States with tables showing comparative values for different assumed conditions.

Tables LII to LVII, inclusive, are compiled from the following formula:

$$P = \left(C + \frac{3f'_s \times A'_s}{r} \right) A + f_s A_s \dots \dots \dots (22)$$

where P = safe load in lbs.

C = stress in concrete per sq. inch (500 lbs. or 750 lbs.)

$$f_s = \frac{E_s}{E_c} C = nC$$

f'_s = tensile stress in hoop

A = area of concrete inside hoop

A_s = area of longitudinal rods

A'_s = area of hoops per unit height of column

r = radius of concrete core inside of hoop

In these tables medium steel is assumed where $f'_s = 16,000$ lbs. per sq. in.

TABLE LII.—HOOPED COLUMNS; $n=12$; $C=500$.

$\frac{1}{4}$ -in. Hooping at $1\frac{1}{2}$ ins. centers.

Safe Load.	0.5%.			0.7%.		
	Diameter of Hooping in ins.	Area of Concrete in sq. ins.	Area of Steel in sq. ins.	Diameter of Hooping in ins.	Area of Concrete in sq. ins.	Area of Steel in sq. ins.
100,000	12.78	128	.64	12.72	127	.889
150,000	16.24	206	1.03	16.12	203	1.42
200,000	19.24	300	1.50	19.16	287	2.11
250,000	21.84	374	1.87	21.72	370	2.54
300,000	24.04	452	2.26	23.92	449	3.14
350,000	26.0	530	2.65	25.92	527	3.68
400,000	28.0	616	3.08	27.92	611	4.28
450,000	30.0	706	3.53	29.72	693	4.84
500,000	31.84	792	3.96	31.62	784	5.45
550,000	33.44	876	4.38	33.32	871	6.02
600,000	35.0	960	4.80	34.92	957	6.70
650,000	36.64	1050	5.25	36.32	1035	7.20
700,000	38.0	1130	5.65	37.72	1116	7.81
750,000	39.6	1232	6.16	39.12	1200	8.40
800,000	41.0	1320	6.60	40.52	1288	9.00
850,000	42.3	1406	7.03	41.90	1379	9.65
900,000	43.6	1494	7.47	43.00	1452	10.20
950,000	44.9	1584	7.92	44.50	1555	10.90
1,000,000	46.2	1676	8.37	45.70	1640	11.50

$\frac{1}{4}$ -in. Hooping at 2 ins. centers.

100,000	13.5	143	.72	13.3	139	.97
150,000	17.0	227	1.13	16.8	222	1.53
200,000	19.8	308	1.54	19.6	302	2.12
250,000	22.4	394	1.97	22.2	387	2.72
300,000	24.6	475	2.38	24.2	468	3.35
350,000	26.8	564	2.84	26.5	552	3.90
400,000	28.9	656	3.28	28.6	642	4.50
450,000	30.7	740	3.70	30.4	725	5.10
500,000	32.6	834	4.17	32.2	814	5.70
550,000	34.3	924	4.62	33.9	903	6.40
600,000	36.1	1024	5.12	35.7	1001	7.00
650,000	37.5	1104	5.52	37.0	1057	7.30
700,000	38.9	1188	5.94	38.5	1164	8.15
750,000	40.3	1276	6.38	39.8	1244	8.70
800,000	41.7	1366	6.83	41.3	1340	9.35
850,000	43.0	1452	7.26	42.6	1425	10.15
900,000	44.4	1548	7.74	44.0	1521	10.60
950,000	45.6	1633	8.16	45.2	1604	11.20
1,000,000	47.0	1735	8.68	46.4	1691	11.80

TABLE LIII.—HOOPED COLUMNS; $n=12$; $C=500$. $\frac{3}{4}$ -in. Hooping at $1\frac{1}{2}$ ins. centers.

Safe Load.	0.5%.			0.7%.		
	Diameter of Hooping in ins.	Area of Concrete in sq. ins.	Area of Steel in sq. ins.	Diameter of Hooping in ins.	Area of Concrete in sq. ins.	Area of Steel in sq. ins.
100,000	10.2	81.7	.41	10.2	81.7	.57
150,000	13.5	143	.71	13.3	139	.98
200,000	16.2	206	1.03	16.0	201	1.41
250,000	18.8	278	1.39	18.6	272	1.90
300,000	21.0	346	1.73	20.8	340	2.38
350,000	23.0	415	2.07	22.6	401	2.81
400,000	25.0	491	2.45	24.8	483	3.38
450,000	27.0	572	2.86	26.6	556	3.90
500,000	28.8	651	3.26	28.4	633	4.45
550,000	30.4	726	3.63	30.0	707	4.95
600,000	32.0	804	4.02	31.6	784	5.50
650,000	33.6	887	4.44	33.0	855	6.00
700,000	35.0	962	4.81	34.6	940	6.60
750,000	36.4	1040	5.20	35.8	1007	7.10
800,000	37.8	1122	5.61	37.4	1098	7.60
850,000	39.2	1207	6.03	38.6	1170	8.20
900,000	40.4	1282	6.41	39.8	1244	8.70
950,000	41.8	1372	6.86	41.2	1333	9.20
1,000,000	43.0	1452	7.26	42.4	1412	9.90

 $\frac{3}{4}$ -in. Hooping at 2 ins. centers.

100,000	11.3	100	.50	11.2	98	.69
150,000	14.7	170	.85	14.5	165	1.16
200,000	17.5	240	1.20	17.3	235	1.65
250,000	20.0	314	1.57	19.8	308	2.15
300,000	22.3	390	1.95	22.0	380	2.66
350,000	24.4	467	2.34	24.2	460	3.22
400,000	26.4	547	2.73	26.2	539	3.79
450,000	28.3	629	3.15	28.0	615	4.30
500,000	30.0	706	3.53	29.7	692	4.83
550,000	31.7	789	3.95	31.4	774	5.41
600,000	33.3	870	4.35	33.0	855	5.97
650,000	34.9	956	4.78	34.6	940	6.59
700,000	36.4	1040	5.20	36.1	1023	7.17
750,000	37.8	1122	5.61	37.4	1098	7.70
800,000	39.1	1200	6.00	38.7	1176	8.23
850,000	40.4	1281	6.41	40.0	1256	8.75
900,000	41.7	1366	6.83	41.3	1339	9.36
950,000	43.0	1452	7.26	42.6	1425	9.97
1,000,000	44.3	1541	7.70	43.9	1514	10.62

TABLE LIV.—HOOPED COLUMNS; $n=12$; $C=500$.

$\frac{3}{4}$ -in. Hooping at $1\frac{1}{2}$ ins. centers.

Safe Load.	0.5%.			0.7%.		
	Diameter of Hooping in ins.	Area of Concrete in sq. ins.	Area of Steel in sq. ins.	Diameter of Hooping in ins.	Area of Concrete in sq. ins.	Area of Steel in sq. ins.
100,000	7.6	45	.226	7.6	45	.32
150,000	10.6	88	.44	10.4	85	.59
200,000	13.4	141	.70	12.8	133	.93
250,000	15.4	186	.93	15.2	181	1.27
300,000	17.6	243	1.21	17.4	238	1.66
350,000	19.4	296	1.47	19.2	289	2.02
400,000	21.4	359	1.79	21.2	353	2.48
450,000	23.0	415	2.08	22.8	408	2.86
500,000	24.6	475	2.37	24.6	475	3.34
550,000	26.4	547	2.72	26.2	539	3.77
600,000	28.0	616	3.08	27.6	598	4.20
650,000	29.4	679	3.40	29.2	670	4.70
700,000	31.4	774	3.87	30.6	735	5.15
750,000	32.2	814	4.08	32.0	804	5.65
800,000	33.6	887	4.46	33.3	870	6.10
850,000	34.8	951	4.76	34.6	940	6.60
900,000	36.2	1029	5.15	35.8	1006	7.00
950,000	37.4	1098	5.45	37.2	1086	7.60
1,000,000	38.8	1182	5.90	38.4	1158	8.10

$\frac{3}{4}$ -in. Hooping at 2 ins. centers.

100,000	9.0	64	.32	9.	63	.45
150,000	12.1	115	.57	12.	113	.78
200,000	14.6	167	.84	14.4	163	1.14
250,000	17.3	235	1.17	17.0	227	1.58
300,000	19.5	299	1.49	19.2	289	2.03
350,000	21.6	366	1.83	21.3	356	2.48
400,000	23.4	430	2.15	23.1	419	2.93
450,000	25.2	499	2.49	24.9	487	3.40
500,000	27.0	572	2.89	26.7	560	3.90
550,000	28.5	638	3.19	28.2	624	4.37
600,000	30.1	711	3.55	29.8	697	4.87
650,000	31.7	789	3.94	31.4	774	5.40
700,000	33.2	865	4.33	32.9	850	5.95
750,000	34.7	946	4.73	34.4	929	6.52
800,000	35.9	1012	5.06	35.6	995	6.97
850,000	37.2	1086	5.43	36.9	1069	7.50
900,000	38.3	1152	5.76	38.0	1134	7.91
950,000	39.6	1231	6.16	39.2	1207	9.45
1,000,000	41.1	1327	6.63	40.7	1301	10.10

500— $\frac{1}{2}$ "

REINFORCED CONCRETE.

TABLE LV.—HOOPED COLUMNS; $n=15$; $C=750$.

½-in. Hooping at 1½ ins. centers.

Safe Load.	0.5%.			0.7%.		
	Diameter of Hooping in ins.	Area of Concrete in sq. ins.	Area of Steel in sq. ins.	Diameter of Hooping in ins.	Area of Concrete in sq. ins.	Area of Steel in sq. ins.
100,000	10.8	92	.46	10.6	88	.62
150,000	13.6	145	.72	13.4	141	.99
200,000	16.0	201	1.00	15.8	196	1.37
250,000	18.0	254	1.27	17.8	248	1.74
300,000	20.0	314	1.57	19.8	306	2.15
350,000	21.6	366	1.83	21.4	360	2.53
400,000	23.2	423	2.11	23.0	415	2.90
450,000	24.8	483	2.41	24.6	475	3.32
500,000	26.3	543	2.72	26.0	530	3.70
550,000	27.7	603	3.01	27.4	589	4.15
600,000	28.9	656	3.28	28.6	642	4.50
650,000	30.2	716	3.56	29.8	697	4.95
700,000	31.4	774	3.87	31.0	755	5.30
750,000	32.6	835	4.17	32.2	814	5.70
800,000	33.6	887	4.43	33.2	866	6.05
850,000	34.8	951	4.75	34.4	929	6.50
900,000	35.8	1006	5.08	35.4	984	6.90
950,000	36.8	1064	5.32	36.4	1040	7.30
1,000,000	37.8	1122	5.61	37.4	1099	7.70

½-in. Hooping at 2 ins. centers.

100,000	11.2	99	.50	11.1	97	.69
150,000	14.0	154	.77	13.8	150	1.05
200,000	16.3	209	1.05	16.1	204	1.43
250,000	18.4	266	1.33	18.2	260	1.62
300,000	20.3	324	1.62	20.1	317	2.21
350,000	22.0	380	1.90	21.8	373	2.62
400,000	23.7	441	2.20	23.5	434	3.03
450,000	25.2	499	2.50	24.9	487	3.41
500,000	26.6	556	2.78	26.5	543	3.80
550,000	28.0	616	3.08	27.7	603	4.22
600,000	29.3	674	3.37	29.0	660	4.62
650,000	30.6	735	3.68	30.3	721	5.05
700,000	31.8	794	3.97	31.4	774	5.42
750,000	33.0	855	4.28	32.6	835	5.85
800,000	34.1	913	4.56	33.7	892	6.24
850,000	35.2	973	4.86	34.8	951	6.66
900,000	36.3	1035	5.17	35.9	1012	7.08
950,000	37.3	1093	5.46	36.8	1064	7.44
1,000,000	38.4	1158	5.79	37.9	1128	7.89

750—¼"

TABLE LVI.—HOOPED COLUMNS; $n=15$; $C=750$.

$\frac{1}{4}$ -in. Hooping at $1\frac{1}{2}$ ins. centers

Safe Load.	0.5%.			0.7%.		
	Diameter of Hooping in ins.	Area of Concrete in sq. ins.	Area of Steel in sq. ins.	Diameter of Hooping in ins.	Area of Concrete in sq. ins.	Area of Steel in sq. ins.
100,000	9.0	64	.32	9.0	64	.45
150,000	11.5	104	.52	11.4	102	.71
200,000	14.0	154	.77	13.8	150	1.05
250,000	15.9	198	.99	15.7	194	1.36
300,000	17.8	249	1.24	17.6	243	1.70
350,000	19.4	296	1.46	19.3	293	2.05
400,000	21.0	346	1.73	20.8	339	2.35
450,000	22.5	398	1.99	22.4	394	2.68
500,000	24.0	452	2.26	23.8	445	3.12
550,000	25.4	507	2.53	25.1	495	3.46
600,000	26.8	564	2.82	26.4	547	3.84
650,000	28.0	616	3.08	27.6	598	4.28
700,000	29.2	670	3.35	28.8	651	4.56
750,000	30.3	721	3.61	29.9	702	4.90
800,000	31.4	774	3.87	31.0	755	5.30
850,000	32.5	830	4.15	32.0	804	5.65
900,000	33.6	887	4.43	33.0	855	6.00
950,000	34.6	940	4.70	34.0	908	6.35
1,000,000	35.6	995	4.95	35.0	962	6.75

$\frac{1}{4}$ -in. Hooping at 2 ins. centers.

100,000	9.7	74	.37	9.5	71	.49
150,000	12.5	122	.61	12.3	119	.83
200,000	14.8	172	.86	14.6	167	1.17
250,000	17.0	227	1.14	16.7	219	1.58
300,000	18.8	278	1.39	18.5	269	1.88
350,000	20.4	327	1.64	20.1	317	2.23
400,000	22.0	380	1.90	21.7	370	2.58
450,000	23.6	437	2.19	23.3	426	2.97
500,000	25.0	491	2.46	24.7	479	3.35
550,000	26.3	543	2.72	26.0	531	3.72
600,000	27.6	598	2.99	27.3	585	4.10
650,000	28.8	651	3.26	28.5	638	4.45
700,000	30.1	712	3.56	29.7	693	4.85
750,000	31.2	765	3.83	30.8	745	5.20
800,000	32.4	824	4.12	32.0	804	5.63
850,000	33.5	881	4.41	33.1	860	6.02
900,000	34.5	935	4.63	34.0	908	6.34
950,000	35.6	995	4.97	35.1	968	6.77
1,000,000	36.7	1058	5.29	36.2	1029	7.20

TABLE LVII.—HOOPED COLUMNS; $n=15$; $C=750$.

Safe Load.	0.5%.			0.7%.		
	Diameter of Hooping in ins.	Area of Concrete in sq. ins.	Area of Steel in sq. ins.	Diameter of Hooping in ins.	Area of Concrete in sq. ins.	Area of Steel in sq. ins.
	100,000	7.0	38	.19	7.0	38
150,000	9.5	71	.36	9.5	71	.50
200,000	11.6	106	.53	11.6	106	.74
250,000	13.4	141	.71	13.4	145	1.00
300,000	15.2	181	.91	15.2	181	1.27
350,000	17.0	227	1.14	16.9	224	1.55
400,000	18.6	272	1.36	18.4	266	1.86
450,000	20.0	314	1.57	19.7	305	2.14
500,000	21.4	360	1.80	21.0	346	2.42
550,000	22.6	401	2.00	22.3	391	2.74
600,000	23.8	445	2.23	23.6	437	3.06
650,000	25.0	491	2.46	24.7	479	3.36
700,000	26.4	547	2.74	26.2	539	3.77
750,000	27.5	594	2.97	27.2	581	4.06
800,000	28.6	642	3.21	28.2	625	4.38
850,000	29.6	688	3.44	29.2	670	4.69
900,000	30.6	735	3.68	30.4	726	5.08
950,000	31.6	784	3.92	31.4	774	5.40
1,000,000	32.6	835	4.17	32.4	824	5.77

½-in. Hooping at 2 ins. centers.

100,000	8.0	50	.25	8.0	50	.35
150,000	10.6	88	.44	10.5	87	.61
200,000	12.8	129	.65	12.7	127	.89
250,000	14.9	174	.87	14.7	170	1.19
300,000	16.7	219	1.09	16.5	214	1.50
350,000	18.4	266	1.33	18.2	260	1.81
400,000	20.0	314	1.57	19.8	308	2.15
450,000	21.5	363	1.82	21.2	353	2.47
500,000	22.9	412	2.06	22.6	401	2.79
550,000	24.2	460	2.30	23.9	449	3.13
600,000	25.5	511	2.56	25.2	499	3.42
650,000	26.7	560	2.80	26.4	547	3.82
700,000	28.0	616	3.08	27.7	602	4.20
750,000	29.1	665	3.33	28.7	647	4.51
800,000	30.2	716	3.58	29.8	697	4.87
850,000	31.3	769	3.85	31.0	754	5.28
900,000	32.3	819	4.09	32.0	804	5.63
950,000	33.3	871	4.36	33.0	855	5.98
1,000,000	34.4	929	4.64	34.0	910	6.37

750— $\frac{1}{2}$ "

Consideré's Formula.—Consideré's empirical formula is as follows:

$$P = 1.5 CA + \frac{x A}{100} f_s + 2.4 \frac{y A}{100} f'_s \dots\dots\dots (23)$$

where P = ultimate column load

C = crushing strength of concrete per unit

x = percentage of vertical steel reinforcement

y = percentage of horizontal steel reinforcement

A = area of concrete inside the hoops

f_s = elastic limit of vertical steel reinforcement

f'_s = elastic limit of horizontal steel reinforcement

Table LVIII, based upon Consideré's formula, gives ultimate loads for hooped columns as used in the American System of Reinforcing; Chicago, using high tensile strength steel, while the tables previous to this one give safe working values and are based upon medium steel. The values in Table LVIII should be divided by four to give a working load. It may be added that this table is based upon the elastic limit of No. 7 wire, which is 90,000 lbs. and with $\frac{1}{4}$ and $\frac{3}{8}$ in. rods of 40,000 lbs. and $C=2,800$ lbs. per sq. in.

TABLE LVIII.—HOOPED COLUMNS, CONSIDERE'S FORMULA.

Ultimate Loads, High Carbon Steel. For working loads, divide by 4.

Diameter of Column in. ins.	Diameter of Spiral in. ins.	Percentage of vertical reinforcement	90,000	40,000	40,000
			No. 7 gage.	$\frac{1}{2}$ -in. round.	$\frac{3}{8}$ -in. round.
			Area = 0.023 sq. ins.	Area = 0.0491 sq. ins.	Area = 0.1104 sq. ins.
			1 in. pitch.	$1\frac{1}{2}$ ins. pitch.	$1\frac{1}{2}$ ins. pitch.
10	8	1	365,000	311,000	407,000
		2	385,000	330,000	430,000
		3	405,000	350,000	447,500
12	10	1	528,000	460,000	581,000
		2	560,500	491,000	612,500
		3	590,000	522,500	643,000
14	12	1	720,500	638,000	784,000
		2	765,500	683,500	830,000
		3	810,500	728,000	875,000
16	14	1	941,500	846,000	1,016,000
		2	1,003,000	907,000	1,077,500
		3	1,064,500	969,000	1,139,000
18	16	1	1,191,500	1,082,000	1,276,500
		2	1,272,000	1,162,500	1,357,000
		3	1,353,000	1,243,000	1,437,000
20	18	1	1,470,000	1,338,000	1,566,000
		2	1,572,000	1,439,500	1,668,000
		3	1,674,000	1,541,000	1,769,500
22	20	1	1,778,000	1,641,500	1,884,500
		2	1,903,500	1,767,000	2,010,000
		3	2,029,000	1,893,000	2,136,000
24	22	1	2,115,000	1,964,500	2,232,000
		2	2,267,000	2,116,500	2,384,000
		3	2,419,000	2,268,500	2,536,000
26	24	1	2,480,500	2,316,500	2,608,000
		2	2,661,500	2,497,500	2,789,000
		3	2,842,000	2,678,500	2,970,000
28	26	1	2,875,000	2,697,500	3,013,000
		2	3,087,000	2,909,500	3,225,500
		3	3,299,500	3,122,000	3,437,500
30	28	1	3,298,000	3,107,000	3,447,000
		2	3,544,500	3,353,000	3,693,500
		3	3,790,500	3,599,500	3,939,500

Note.—This table should be used only for those columns where $\frac{l}{d} < 18$.

Euler's Formula.—Where height of columns is over 25 times their least diameter, Euler's formula may be used to advantage:

$$P = 39.48 \frac{\left(\frac{d^4}{12} + nA_s y^2\right) E_c}{l^2} \dots\dots\dots (24)$$

where $n = \frac{E_s}{E_c}$

d = side of square column

A_s = area of steel reinforcement

y = distance of center of reinforced bars from the axial plane of column

Instead of using the expression $\frac{l}{d}$, Euler's formula uses the smallest radius of gyration, which is a function of the moment of inertia,

$$I = Ar^2$$

Thus for a square column we have

$$r^2 = \frac{b^2}{12}$$

For a hollow square column

$$r^2 = \frac{B^2 + b^2}{12}$$

For a round column

$$r^2 = \frac{d^2}{16}$$

For a hollow round column

$$r^2 = \frac{D^2 + d^2}{16}$$

Euler's formula for pin ends is

$$\pi^2 E A \left(\frac{r_1}{l}\right)^2$$

The breaking load is

$$P = \frac{\pi^2 EI}{l^2} = \pi^2 E A \left(\frac{r}{l}\right)^2$$

where A = the area of the column in sq. in.

E = the modulus of elasticity in lbs. per sq. in.

r = the radius of gyration in inches

l = length of column in inches

and P is expressed in lbs.

A factor of safety, of from 5 to 8 is used.

Euler's formula is not often used in the United States, where Gordon's, Rankine's or Cooper's formula is preferred.

STRUCTURAL DETAILS.

Roofs.—Concrete roofs of nearly every description have been built both abroad and in America. They are either built the same as floors or beams and girders, for slightly sloping roofs, or by means of floor slabs molded in situ between the iron trusses of the building. A third method is to place concrete slabs made at the factory on top of rafters and then cover the slabs with tile or other protection. For factories, shops, blast furnaces, mines, steel mills, etc., where corrugated iron has for many years been employed, the latter is now being replaced by roofing plates, interlocked and fastened to the rafters. This method was first patented by the author, who applied it on roofs of the Illinois Steel Company's buildings at Chicago, a cement storage house at the same place, the large blacksmith shop of the C. & N. W. railway at Chicago and to the company's Pintch gas plant. The plates were made waterproof, of a mixture of 1 cement to 3 torpedo sand, 2 ft. wide, 5 ft. long and only $\frac{7}{8}$ in. thick. They are self-locking and removable, similar to corrugated iron sheets. The reinforcement consisted of a wire fabric, which in this case was electrically welded. Roofs for saw-tooth factories are also often built of a tile concrete construction laid on top of steel rafters. For flat roofs the concrete slabs must be covered by some composition, while for inclined roofs, roofing plates may be put on without covering.

Stairs.—Reinforced concrete stairs are easily constructed and are rapidly coming into use, even on existing brick buildings where wooden porches and stairs have been employed. There are five kinds of stair construction in reinforced concrete:

(1) Concrete steps manufactured in shops and fitted on top of inclined concrete slabs.

- (2) Similar steps fitted to iron stringers.
- (3) Plain inclined slab with top side toothed to form risers and treads.
- (4) Soffit and top molded in connection with the stringers and cast in one piece. In this case the top is toothed for risers and the soffit may be either flat or toothed to conform with the profile of the top.
- (5) Stairs attached to concrete wall on one side and overhanging.

The general construction of stairs is based upon the same calculations as have been presented under floor beams and girders and need not be further detailed. A wire fabric forms a very satisfactory reinforcement between the stringers for continuous stairs, and one layer is generally sufficient, adding to the cheapness and rapidity of the construction.

At the Lakeside Hospital in Chicago the author constructed porches along the rear of the hospital so as to make verandas on each floor for the patients and have the construction absolutely fireproof. The porches were 10 ft. wide and 40 ft. long and rested on 8x8-in. reinforced concrete columns extending down to the foundation in the basement of the building. There were four verandas and the inner edges rested on angle irons extending 4 ins. into the brick building, being anchored thereto. The stairs were 4 ft. wide and molded in place, each with two stringers supporting a flat soffit slab with the top toothed for risers and treads. The railings were made of 2-in. wrought iron pipe in the usual manner, the posts being inserted and wedged to wrought iron sleeves previously molded into the concrete stringers and beams and the railings then fastened to same and into the brick wall of the building at both ends of the veranda.

Concrete porches and stairs are rapidly replacing the common wooden constructions in the rear of tenement houses and apartment buildings of large cities.

Structural Steel or Cast Iron Columns.—Structural steel or cast iron columns are frequently employed in reinforced

concrete structures on account of rapidity in erection after they have been delivered on the premises. If structural steel columns, owing to their smaller floor area, are employed, Fig. 61, gives a typical view of the attachment of girder and floor beams, and Fig. 62 shows a view of the

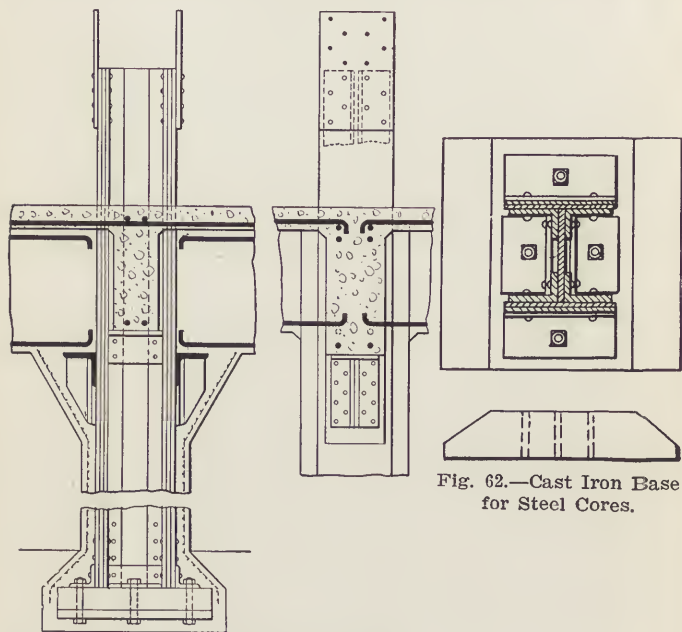

Fig. 61.—Steel Core Column Footing and Bracket for Beam and Girder Connection.

Fig. 62.—Cast Iron Base for Steel Cores.

base for same. Fig. 63 indicates the reinforcing of a heavy steel floor girder and a method of running the slab beams into same. This construction was used in the Eagle Warehouse & Storage Company's building on Fulton St., Brooklyn, N. Y.

The steel columns are proportioned for working stresses of 16,000 lbs. per sq. in., the hollow columns being filled with concrete (Fig. 64). The cast iron columns in this building are generally 12 ins. in diameter down to the fourth floor and 15 ins. to the second floor with thicknesses varying

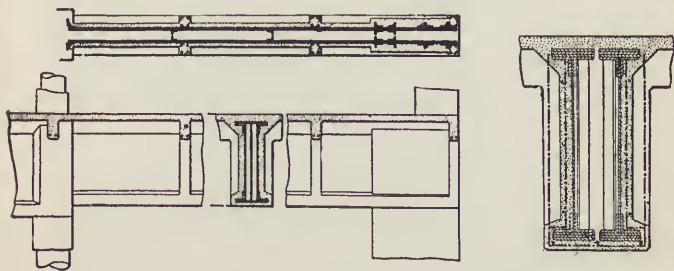

Fig. 63.—Fireproofing of Box Girder and Twin Girder.

from $1\frac{1}{4}$ ins. to $1\frac{3}{4}$ ins. and lengths of from 12 ft. 6 ins. to 13 ft. They are of standard construction. Fig. 65 shows flange connections faced and drilled for $\frac{3}{4}$ -in. connection bolts. The upper ends of the columns are special in that, above the beams and girder seats, they are made square outside with rectangular openings 5 or 6 ins. wide and 14 ins. deep in the face, to permit the reinforcement rods in beams and girders to pass through for purposes of continuity. The fireproofing concrete is extended 2 ins. beyond the flanges and carefully finished with beveled fillets. The brick walls are carried at every story by reinforced concrete girders (Fig. 66) with their outer face $4\frac{1}{2}$ ins. clear of the outer face of the brick work. The concrete walls are 12 ins. thick for the first three stories, 10 ins. for the next two, 9 ins. for the next two, and 8 ins. for the upper story, reinforced with $\frac{1}{2}$ -in. rods 2 $\frac{1}{2}$ ft. on centers running horizontally and $\frac{1}{2}$ -in. rods 3 ft. on centers running vertically.

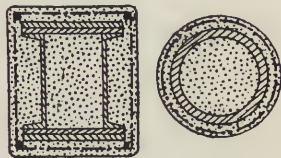

Fig. 64.—Fireproofing and Filling for Columns.

The author invariably uses wire fabric for walls, running it through the reinforced concrete columns and connecting with floor and ceiling, both to prevent temperature cracks and to guard against cracks resulting from uneven settling of the building foundation.

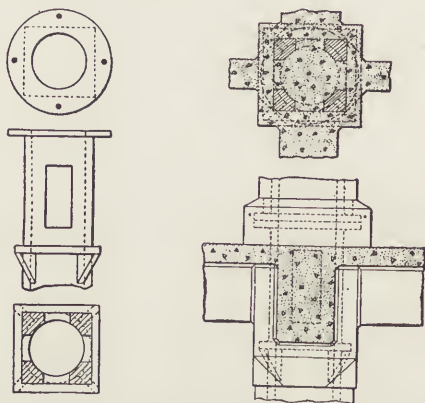

Fig. 65.—Special Top for Cast Iron Column; Column and Girder Connections.

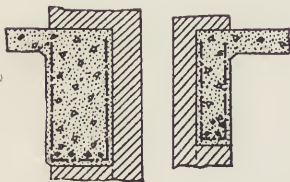

Fig. 66.—Concrete Girders Supporting Brick Walls.

The author also has advocated a construction in which the structural steel, correctly located, should be calculated to assume the dead loads of the building as well as the loads incidental to the building erection and wind pressure—and afterwards incased in concrete in a manner to support the additional live load. Such a building could be erected with the rapidity inherent in the traditional skyscraper and several floors put in simultaneously without waiting for the setting of the column concrete from floor to floor. This construction has been adopted by several well known engi-

neers. As an example, the construction employed by Mr. Guy B. Waite, New York City, is here illustrated.

Fig. 67 shows details of the general construction. The original beams and girders consist of small I-beams usually from 4 to 5 ins. deep, entering into the columns and connected to them by bent plates and angles. The column itself consists of four angles latteded together, so designed as to form when filled with concrete a reinforcement with a maximum radius of gyration. The column details, of course, may be changed. In such construction it hardly needs to

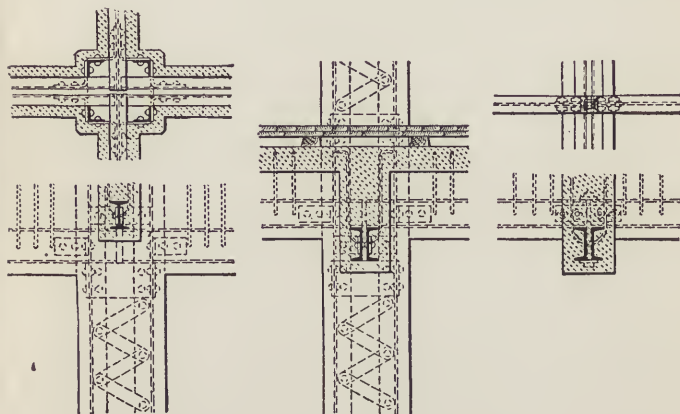

Fig. 67.—General Structural Details.

be added that the support of molds and scaffolding is simply a matter of hooks, no floor supports being required.

Bracket Connections.—Figure 68 shows a typical beam floor slab construction with hooped column supports and Fig. 69 the construction of the connection. The brackets are reinforced by one or more corner rods from $\frac{5}{8}$ to 1 in. in diameter hooked at the ends to withstand eccentric loads and wind pressure. Fig. 70 shows a typical footing for such a column on rock. Sometimes the bearing plate consists of

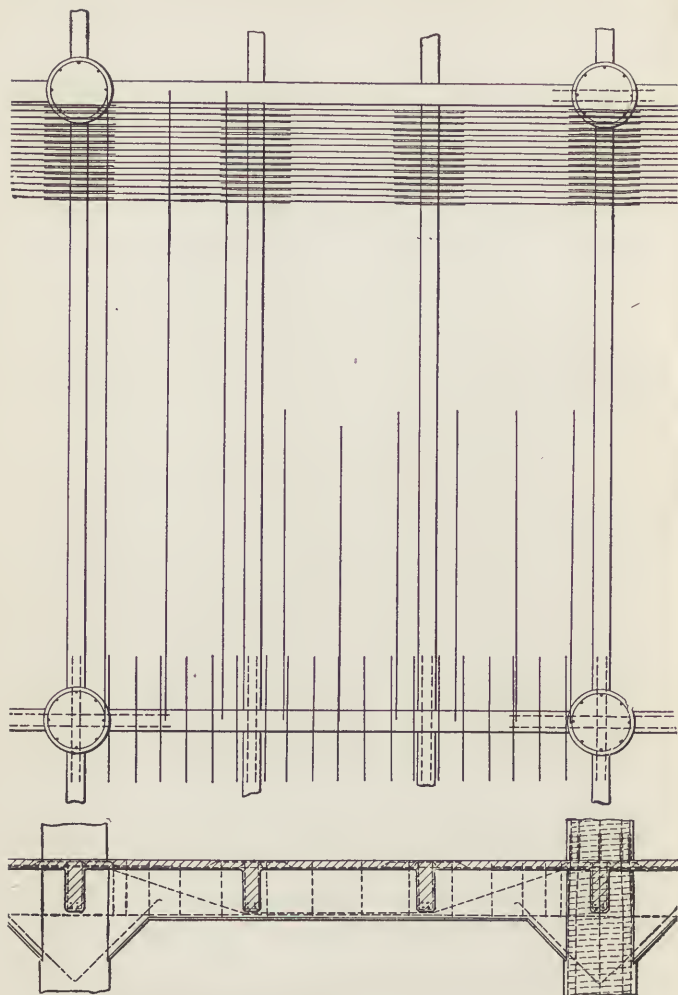

Fig. 68.—Typical Beam Floor Slab Construction.

one plate the same as before quoted. Sometimes economy is gained by using short flat bars, as here shown.

Fig. 71 shows a typical wall beam and its connection to a girder and bracket to the column. The wall beams usually represent the entire panel between the lintel of one floor opening and the sill of the opening on floor above.

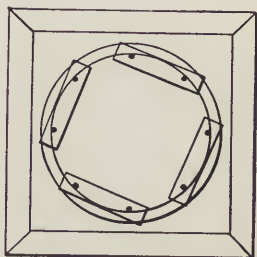
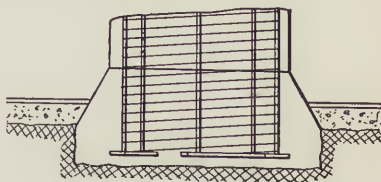
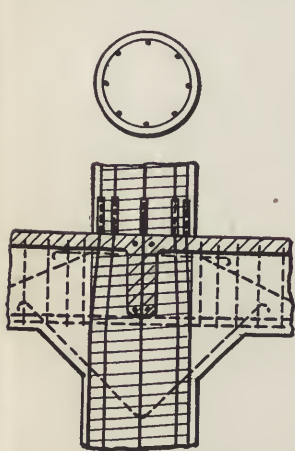

Fig. 69.—Typical Beam, Girder and Column Connection.

Fig. 70.—Typical Footing for Column on Rock.

EXAMPLE OF BUILDING DESIGNED ACCORDING TO THE FOREGOING PRINCIPLES.

In order to illustrate the use of the tables given under Building Design, and to illustrate further the principles underlying the design of raft foundations, the following example is given:

Assumptions.—It is required to design a warehouse, 60 by 60 ft. square, 6 stories in height, with basement. (Fig. 72.) In the southeast corner, above the roof, is a garner, weighing with contents 200,000 lbs. The live load on floors is 182 lbs. per sq ft., and on the roof the live load is 78 lbs. per

sq. ft. The property on the north is not occupied, but must not be encroached upon. On the east stands a heavy warehouse without basement, hence its foundations are comparatively shallow, so that the basement of the new building is 2 ft. below the bottom of foundations of this property.

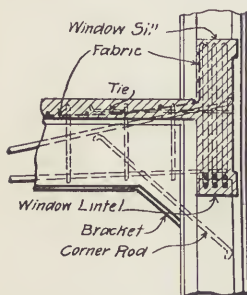

Fig. 71.—Typical Bracket and Ties at Walls.

Soil is stratified, sustaining a pressure of 5,000 lbs. per sq. ft. Time prevents the driving of piling, which also would endanger the adjoining building. A reinforced concrete mat and raft foundation is decided upon.

The calculations, based upon a 1-6 mixture of Portland cement, sand and crushed stone passing a $\frac{3}{4}$ -in. ring, are as follows, for the first to the sixth floors inclusive, assuming that beams are spaced 7 ft. 6 ins. on centers, and that girders are spaced 15 ft. on centers:

Slabs.—Assuming a span of 7 ft. and a dead load of 64 lbs. per sq. ft.,

$$182 + 64 = 246 \text{ lbs. per sq. ft.}$$

Referring to Table L, and taking

$$p = 0.006 \text{ and } C = 580, h = 5 \text{ ins.}$$

The steel area per foot is .288 sq. in., from same table.

Assuming $\frac{1}{2}$ -in. rods as reinforcement, by Table XXXV their area is seen to be 0.196 sq. ins. The spacing accordingly is

$$\frac{0.196}{0.288} \times 12 = 8\frac{1}{8} \text{ ins. on centers}$$

where no fabric is used.

Beams.—We approximate: $W = 8 \times 246 = 1,968$ lbs. per ft. of beam, including the weight of the beam, and assuming a beam 12 ins. wide.

For 1-in. width of beam,

$$w = \frac{1968}{12} = 164 \text{ lbs.}$$

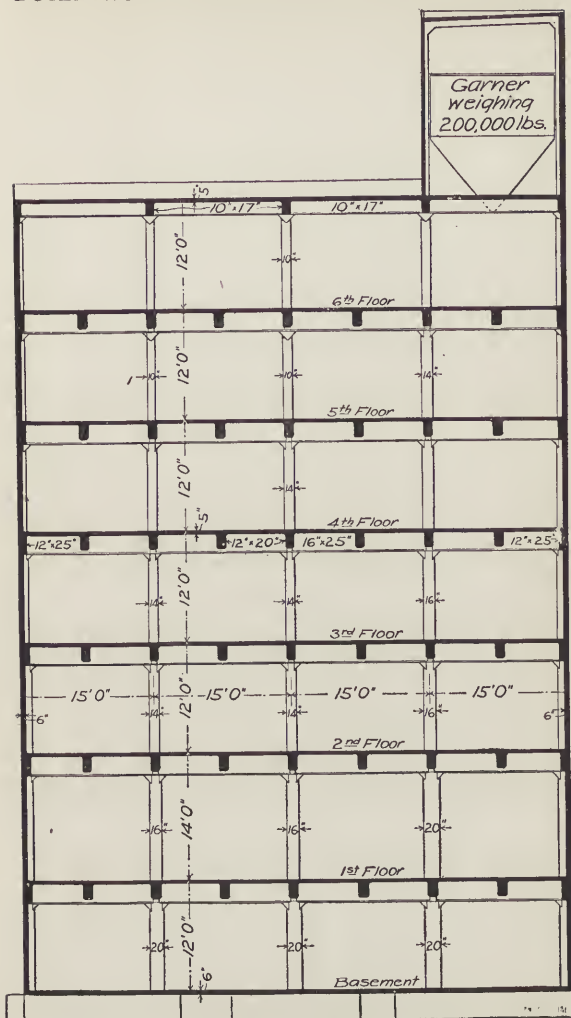

Fig. 72.—Section Through Building.

Table XLVI, for span of 15 ft., gives a depth of 26 ins. for a load of 174 lbs. For 164 lbs. the depth is 25 ins., giving a beam 12x25 ins., or 12x20 ins. below the slab.

The same table gives steel area for 1 in. width between 0.192 and 0.176; assuming 0.190 sq. ins.,

$$0.190 \times 12 = 2.28 \text{ sq. ins.}$$

Assuming 8 rods,

$$228 \div 8 = .285 \text{ sq. ins.,}$$

which corresponds to a diameter of $\frac{5}{8}$ ins.

Later will be shown that two extra rods are laid in such beams as support the columns on a cantilever. All rods are to be carefully fastened in a frame before being placed.

Girders.— $1,968 \times 15 = 29,520$ lbs. concentrated load.

$$\text{Hence } M = \frac{29,520 \times 15}{4} \times 12 = 1,328,400 \text{ in. lbs.}$$

Selecting a width of 16 ins., the moment for 1 in. width becomes

$$M = \frac{1,328,400}{16} = 83,025 \text{ in. lbs.}$$

In Table XLVI we interpolate between a 36-in. depth at 114,694 in. lbs., and a 30-in. depth at 80,125, and find a depth of slightly over 30 ins. for 83,025 in. lbs., leaving the girder practically 16x25 ins. below the slab.

The steel area for 30 ins. depth is 0.224 sq. ins.

$$16 \times 0.224 = 3.584 \text{ sq. ins.}$$

Assuming 8 rods, and consulting Table XXXV,

$$\frac{3.584}{8} = 0.448 \text{ sq. in.}$$

or 8 rods, $\frac{3}{4}$ in. in diameter.

Eight $\frac{3}{4}$ -in. rods are accepted, as no attention has been paid to the fact that the girder is continuous.

Location of Stirrups.—The net span of the beam is seen to be 13 ft. 8 ins., the depth being 25 ins. Using Mr. Ransome's empirical rule for spacing stirrups, Formula 5, Fig. 31,

they would be located $6\frac{1}{4}$ ins., $12\frac{1}{2}$ ins., $18\frac{3}{4}$ ins., and 25 ins. apart, from the end of the beam. This leaves a space of $39\frac{1}{2}$ ins. in the center of the span, which is too great. To eliminate this, the spacing adopted is 6 ins., 14 ins., 20 ins., and 26 ins., thus making the central space 32 ins., and employing 8 stirrups, the material used being $\frac{1}{2}$ -in. square bars. Stirrups for girders are calculated and located in the same manner as for beams.

Wall Girders.—The load is one-half the regular girder load, or 14,760 lbs., plus the weight of the curtain wall between pilasters, which is 13,500 lbs.

Formula for M , with uniform and concentrated load is

$$M = (\frac{1}{4}W_1 + \frac{1}{8}W_2)l = \left(\frac{14,760}{4} + \frac{13,500}{8} \right) 15 \times 12 = 967,950 \text{ in. lbs.}$$

Assuming the same depth as for the other girders, their breadth will be

$$\frac{967,950}{80,125} = .12 \text{ ins.}$$

The steel area is $\frac{3}{4}$ that of the other girders, or $\frac{3}{4}$ of 3.584 sq. ins., or 2.688 sq. ins. Choosing six rods, their diameter is found to be $\frac{3}{4}$ ins. The stirrups and their spacing are calculated as before.

Roof Slab.—We will make the slabs continuous in both directions and omit the center beams. The live and dead load is

$$78 + 64 = 142 \text{ lbs. per sq. ft.}$$

Since a more carefully graded concrete will be used in the roof to increase its impermeability to water, the value for C can be higher, and p will be higher.

$$\text{Taking } p = 0.008, \text{ and } C = 680,$$

Table LI gives for 142 lbs. load and 15 ft. span, a depth of 5 ins., and a steel area of 0.384 sq. in., or, by Table XXXV, using $\frac{5}{8}$ -in. rods, their spacing is

$$\frac{0.3068}{0.384} \times 12 = 9\frac{5}{8} \text{ ins. on centers.}$$

Roof Beams and Roof Girders.—These are calculated alike. Approximately

$W = 142 \times 8.5 = 1,207$ lbs. per linear foot, including weight of beam.

Selecting a width of 10 ins.,

$$W = \frac{1207}{10} = 121 \text{ lbs.}$$

By Table XLVI, this corresponds to a depth of 22 ins. The steel area is $10 \times .160 = 1.60$ sq. ins. Assuming 6 rods, their diameter is found, by Table XXXV, to be $\frac{5}{8}$ in.

Columns.—We first make a column schedule (see pp. 148 and 149), which explains itself. For tall buildings, it is customary to deduct 5 per cent of the live load for the top floor, 10 per cent for the floor below, and 5 per cent more for each floor except the first floor, until 50 per cent of the live load has been deducted. This, however, we will omit in the example, as it amounts to very little, and might tend to complicate the problem.

We will use a column with high carbon wire hooping, and employ different percentages of vertical reinforcement, according to Considere's formula, and Table LVIII. The values in this table being ultimate, are divided by 4 to get the working stress. The 90,000 lbs. for No. 7 gage represents the elastic limit of the wire employed. The other tables for column loads could be used—see Table XXVIII, and Tables LII to LVII.

The calculations are made, bearing in mind that the roof load is 142 lbs. per sq. ft., the floor loads 246 lbs. per sq. ft. The weight of the column is approximate, allowing for not having included brackets, etc.

The spiral in each case is 2 ins. less in diameter than the column for same, and all spirals used are on 1-in. pitch, as shown in Table LVIII.

Foundations.—From tests, the bearing power of the soil is found to be 5,000 lbs. per sq. ft. Fig. 73 shows the foundation lay-out. As we cannot encroach upon the adjacent

property, rafts must be resorted to on the north and east sides. Rafts 2-7, 3-8 and 15-14 are calculated alike.

Raft 2-7.—The principle consists in constructing a base, the center of gravity of which coincides with the center of

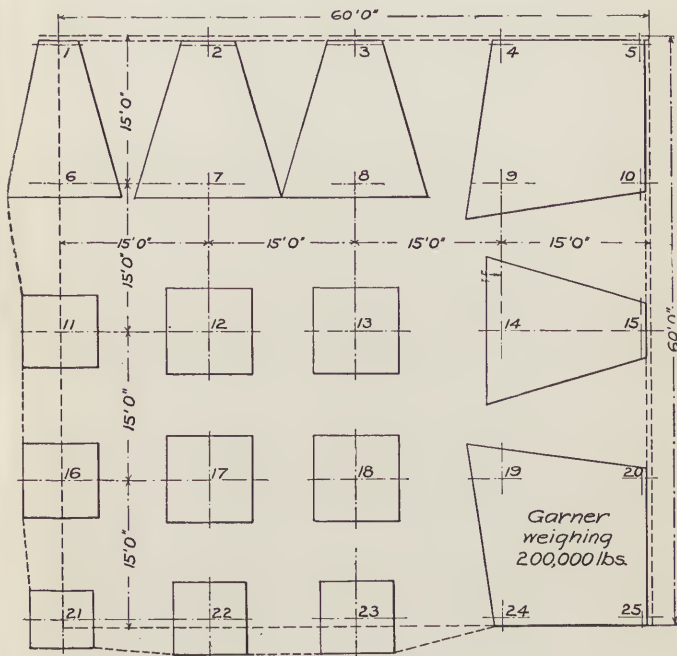

Fig. 73.—Foundation Plan Showing Position of Rafts.

gravity of the two unequal loads. The calculation becomes approximate as we move in the outside column 1 ft., on account of sheet piling, etc., and add 18 ins. at the other end of the raft beyond the centers calculated. See Fig. 74.

COLUMN SCHEDULE.

Floor.	Loads in lbs. per sq. ft.	Columns 1, 5, 21, supporting panel 7½ x 7½ ft.		Columns 7, 8, 9, 12, 13, 14, 17, 18, supporting panel 15 x 15 ft.		Columns 2, 3, 4, 10, 6, 11, 15, 16, 22, 23, supporting panel 7½ x 15 ft.	
6th...	Panel load...	7,988	10-in. col. No.7 gage 1% verti'l reinforce- ment.	31,950	Same as col. 1, 6th floor.	15,975	Same as col. 1, 6th floor.
	Column wt...	1,250		1,250		17,225	
		9,238		33,200			
5th...	Panel load...	13,837	Same as col. 1, 6th floor.	55,350	Same as col. 1, 3rd floor.	27,675	Same as col. 1, 6th floor.
	Column wt...	1,250		3,200		3,200	
	Curtain wall..	13,500			13,500	
		37,825		91,750		59,650	
4th...	Panel load...	13,837	Same as col. 1, 6th floor.	55,350	14-in. col. No.7 gage 1% verti'l reinforce- ment.	27,675	Same as col. 7, 4th floor.
	Column wt...	1,250		3,200		3,200	
	Curtain wall..	13,500			13,500	
		66,412		150,300		104,025	
3rd...	Panel load...	13,837	10-in. col. No.7 gage 3% verti'l reinforce- ment.	55,350	16-in. col. No.7 gage 1% verti'l reinforce- ment.	27,675	Same as col. 7, 4th floor.
	Column wt...	2,450		3,200		3,200	
	Curtain wall..	13,500			13,500	
		96,199		208,850		148,400	
2nd..	Panel load...	13,837	14-in. col. No.7 gage 2% verti'l reinforce- ment.	55,350	16-in. col. No.7 gage 4% verti'l reinforce- ment.	27,675	Same as col. 1, basement.
	Column wt...	2,450		3,600		3,200	
	Curtain wall..	13,500			13,500	
		125,986		267,800		192,775	
1st...	Panel load...	13,837	Same as col. 1, 2nd floor.	55,350	20-in. col. No.7 gage 1% verti'l reinforce- ment.	27,675	16-in. col. No.7 gage 3% verti'l reinforce- ment.
	Column wt...	3,200		4,050		3,600	
	Curtain wall..	15,750			15,750	
		158,773		327,200		239,800	
Base- ment.	Panel load...	13,837	14-in. col. No.7 gage 3% verti'l reinforce- ment.	55,350	20-in. col. No.7 gage 3% verti'l reinforce- ment.	27,675	Same as col. 7, 1st floor
	Column wt...	3,600		4,050		3,600	
	Curtain wall..	13,500			13,500	
		189,710		386,600		284,575	
Founda- tion..	At 5,000 lbs. per sq. ft., or 2.5 tons.	94.86 tons.	37.94 sq. ft.	193.3 tons.	77.3 sq. ft.	142.3 tons.	56.9 sq. ft.

COLUMN SCHEDULE.—(Continued).

Floor.	Loads in lbs. per sq. ft.	Columns 20, 24. Supporting panel 7½ x 15 ft.		Column 19. Supporting panel 15 x 15 ft.		Column 25. Supporting panel 7½ x 7½ ft.	
6th...	Wt. of garner	50,000	10-in. col.	50,000	Same as	50,000	10-in. col.
	Panel load...	15,975	No. 7 gage	31,950	col. 20,	7,988	No. 7 gage
	Column wt...	3,600	3% verti'l	3,600	6th floor.	2,450	1% verti'l
		69,575	reinforce-	85,550		60,438	ment.
5th...	Panel load...	27,675	14-in. col.	55,350	Same as	13,837	Same as
	Column wt...	3,600	No. 7 gage	3,600	col. 20,	2,450	col. 20.
	Curtain wall..	13,500	1% verti'l	5th floor.	13,500	6th floor.
		114,350	reinforce-	144,500		90,225	ment.
4th...	Panel load...	27,675	Same as	55,350	14-in. col.	13,837	14-in. col.
	Column wt...	3,600	col. 20,	3,600	No. 7 gage	3,200	No. 7 gage
	Curtain wall..	13,500	5th floor.	3% verti'l	13,500	2% verti'l
		159,125		203,450	reinforce-	120,762	reinforce-
3rd...	Panel load...	27,675	16-in. col.	55,350	16-in. col.	13,837	Same as
	Column wt...	3,600	No. 7 gage	3,600	No. 7 gage	3,200	col. 25,
	Curtain wall..	13,500	1% verti'l	3% verti'l	13,500	4th floor.
		203,900	reinforce-	262,400	ment.	151,299	
2nd..	Panel load...	27,675	16-in. col.	55,350	Same as	13,837	Same as
	Column wt...	3,600	No. 7 gage	4,000	col. 20,	3,600	col. 19.
	Curtain wall..	13,500	4% verti'l	1st floor.	13,500	4th floor.
		248,675	reinforce-	321,750		182,236	
1st...	Panel load...	27,675	20-in. col.	55,350	20-in. col.	13,837	Same as
	Column wt...	4,000	No. 7 gage	4,800	No. 7 gage	4,000	col. 20,
	Curtain wall..	15,750	1% verti'l	3% verti'l	15,750	3rd floor.
		296,100	reinforce-	381,900	ment.	215,823	
Base- ment.	Panel load...	27,675	Same as	55,350	22-in. col.	13,837	Same as
	Column wt...	4,000	col. 20,	4,000	No. 7 gage	3,600	col. 19,
	Curtain wall..	13,500	1st floor.	2% verti'l	13,500	3rd floor.
		341,275		441,250	reinforce-	246,760	
Founda- tion..	At 5,000 lbs. per sq. ft., or 2.5 tons.	170.6 tons.	68.25 sq. ft.	220.6 tons.	88.2 sq. ft.	123.4 tons.	49.4 sq. ft.

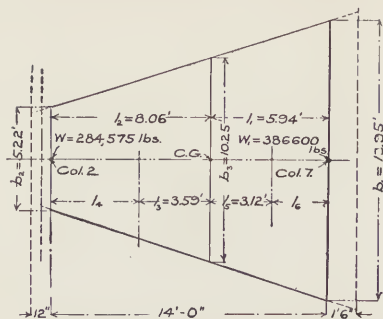

Fig. 74.—Diagram for Raft 2-7.

Load column 2 = 284,575 lbs.

Load column 7 = 386,600 lbs.

Sum = 671,175 lbs.

Dividing by 5,000 = 134.23 sq. ft.

$$\text{Area of raft} = \frac{b_1 + b_2}{2} \times 14 = 134.23.$$

$$b_1 + b_2 = 19.18.$$

$$l_1 = \frac{284575}{671175} \times 14 = 5.94.$$

$$l_1 = \frac{14}{3} \frac{b_1 + 2b_2}{b_1 + b_2} = \frac{14}{3} \frac{b_1 + 2b_2}{19.18} = 5.94.$$

Solving, $b_2 = 5.22$, and $b_1 = 13.95$.

To find the cross-section of raft, we must find the center of gravity of one-half the trapezoid, which gives the leverage for the bending moment, as follows:

$$b_1 - b_2 = 13.95 - 5.22 = 8.73.$$

$$\frac{b_3 - b_2}{8.73} = \frac{l_2}{14} = \frac{8.06}{14}.$$

$$b_3 - b_2 = 5.03.$$

$$b_3 = 5.03 + 5.22 = 10.25.$$

$$l_3 = \frac{l_2}{3} \frac{b_3 + 2b_2}{b_3 + b_2} = \frac{8.06}{3} \times \frac{10.25 + 2 \times 5.22}{10.25 + 5.22} = 3.59.$$

In like manner, solving for l_5 .

$$l_5 = 3.12.$$

Let A = area of entire trapezoid, and a = the area of that part to the left of the center of gravity, CG , then

$$M = Wl_2 - \frac{a}{A} (W + W_1) l_3 = W_1 l_1 - \frac{A-a}{A} (W + W_1) l_5 = 2,294,800 - 1,120,750 = 1,174,050 \text{ ft. lbs.}^*$$

This is $1,174,050 \times 12 = 14,088,600$ in. lbs. Per inch of width this is

$$\frac{14088600}{10.25 \times 12} = 114,540 \text{ in. lbs.}$$

We will choose $n = 15$, as E_c for concrete in a comparatively large mass is nearer 2,000,000.

Choosing $p = 0.01$, we find, from Table XXXIX,

$$1 - \frac{k}{3} = .861.$$

Substituting in Formula (11),

$$M_s = pf \left(1 - \frac{k}{3}\right) bd^2$$

$$M_s = 0.01 \times 16,000 \times 0.861 \times 1 \times d^2.$$

Whence $d = 29$ ins.

Adding 2 ins., we get $h = 31$ ins., for the slab, and the steel area is $0.01 \times 29 = 0.29$ sq. ins. per in. and $0.29 \times 12 = 3.48$ sq. ins. per ft., or, according to Table XXXV, $1\frac{1}{4}$ -in. rods $4\frac{3}{8}$ ins. on centers.

For compression, by combining Formulas (10) and (11),

$$\frac{1}{2}Ck = pf, \text{ or } C = \frac{pf}{\frac{1}{2}k} = \frac{0.01 \times 16000}{\frac{1}{2} \times 0.417}$$

$$C = 767 \text{ lbs. per sq. in., which is safe.}$$

If, however, we specify a maximum safe load in compression of 500 lbs., we find the reinforcement as follows:

*These figures are obtained by using greater accuracy in the measurements than the 2 places of decimals here given.

$$767 - 500 = 267 \text{ lbs. excess.}$$

$$267 \times \frac{kd}{2} = 267 \times \frac{0.417 \times 29}{2} = 1617 \text{ lbs.}$$

$\frac{1617}{16000} = 0.1$ sq. ins. reinforcement required for each one-inch in width, or approximately 1-in. rods every 8 inches.

The distributing rods under column 7 are approximated as follows,* see Fig. 75:

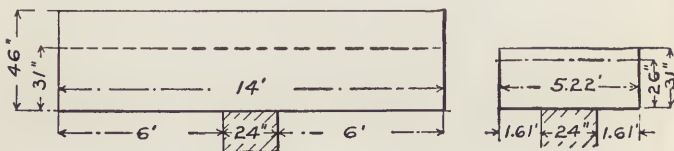

Fig. 75.—Diagrams for Foot of Columns 7 and 2.

$$M = \frac{386600}{2} \times \frac{6}{2} \times 12 = 7,000,000 \text{ in. lbs.}$$

Assuming a width of 36 ins., each inch would have a moment of

$$M = \frac{7000000}{36} = 194,000 \text{ inch lbs.}$$

By Table XLVI, this gives a depth of 46 ins., with a steel area of 0.34 sq. ins. for each inch width.

$36 \times 0.34 = 12.24$ sq. in., which by Table XXXV gives 12 rods, $1\frac{3}{16}$ ins. in diameter (laid in two courses).

Similarly, for column 2,

$$M = \frac{284575}{2} \times \frac{1.61}{2} \times 12 = 1,370,000 \text{ in. lbs.}$$

For a width of 24 ins., this gives per inch,

$$\frac{1370000}{24} = 57,000 \text{ in. lbs.}$$

* To gain practice in using tables, we here use Table XLVI, where $n = 10$ and $p = .008$, instead of 15 and 0.01 respectively.

This corresponds to a depth of 26 ins. and a steel area of 0.192 sq. ins., or $1\frac{1}{4}$ -in. rods 6 ins. on centers. However, this depth will be taken at 31 ins., the same as the slab.

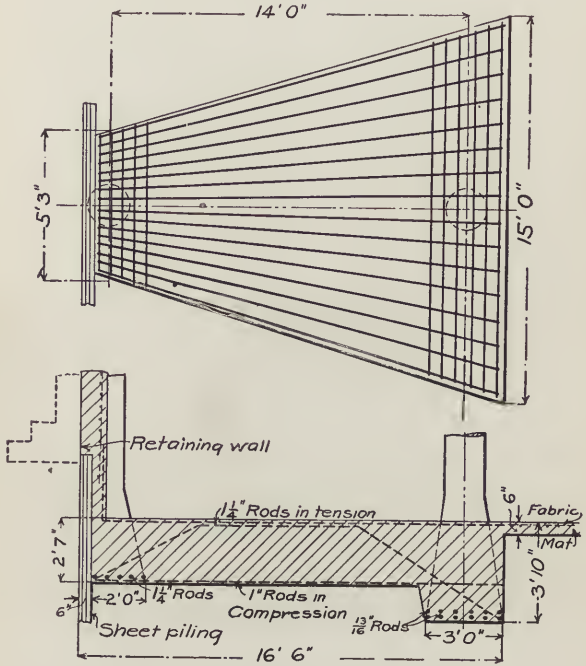

Fig. 76.—Plan and Section of Raft 2-7.

The raft 2-7 will therefore be shown as in Fig. 76, the decimals being replaced by feet and inches.

Rafts 3-8 and 15-14 are like raft 2-7, and raft 1-6 is calculated in a similar manner.

Quadrilateral Raft 4-5-9-10.—See Fig. 77. The outside columns are each moved in 1 ft.

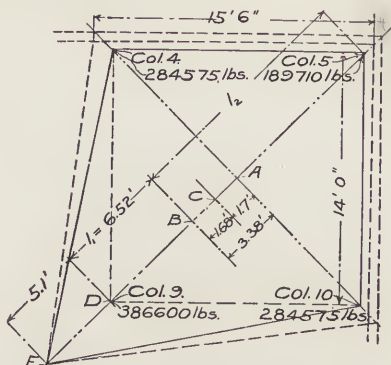

Fig. 77.—Diagram for Raft 4-5-9-10.

$$4 = 284,575 \text{ lbs.}$$

$$5 = 189,710 \text{ lbs.}$$

$$9 = 386,600 \text{ lbs.}$$

$$10 = 284,575 \text{ lbs.}$$

$$1,145,460 \text{ lbs.}$$

$$1,145,460 \div 5,000 = 229.1 \text{ sq. ft.}$$

The center of gravity between 4 and 10 is at the center of a line connecting them, at point *A*, which represents

$$2 \times 284,575 = 569,150 \text{ lbs.}$$

$$5 = 189,710$$

$$9 = 386,600$$

$$B = 576,310$$

$l_1 = \frac{189710}{576310} \times 14 \times 1.414 = 6.52$, which makes the distance between *A* and *B*, 3.38 ft.

$$\text{From } B \text{ to } C = \frac{569150}{1145460} \times 3.38 = 1.68 \text{ ft.}$$

$338 - 1.68 = 1.7$, which locates the center of gravity, C , of the entire raft.

Enough area is added along AD so that the center of gravity of the quadrilateral may be at C . This additional distance DE is $3 \times 1.7 = 5.1$ ft.

The added area is $5.1 \times \frac{14}{2} \times 1.414 = 50$ sq. ft.

Area square 4-5-9-10 is $14 \times 14 = 196$ sq. ft. $196 + 50 = 246$ sq. ft., which is over 229 sq. ft. and therefore safe.

The same method as was employed for raft 2-7 will give the section and reinforcement for raft 4-5-9-10. The raft, as constructed, will measure 15 ft. 6 ins. on the north and east sides, as shown in Fig. 77.

Square Footings, 12, 13, 17 and 18.—See Fig. 78. Since the area required is 77.3 sq. ft., the side is

$$\sqrt{77.3} = 8 \text{ ft. } 9 \text{ in.} \times 8 \text{ ft. } 9 \text{ in.}$$

With a column 20 ins. in diameter, its area is 2.17 sq. ins. The load is 386,600 lbs.

$$2.17 \times 5,000 = 10,850 \text{ lbs.}$$

$$386,600 - 10,850 = 375,750 \text{ lbs.}$$

$$M = \frac{375750}{8} \times \frac{8\frac{3}{4}}{4} \times 12 = 1,232,930 \text{ in. lbs.}$$

or per inch,

$$\frac{1232930}{12} = 102,750.$$

Width of imaginary beam in inches, is

$$\frac{8.75 \times 12}{3} = 35 \text{ ins.}$$

$$\frac{102750}{35} = 2935 \text{ in. lbs. per inch of width.}$$

By Table XLVI, interpolating between 2,555 and 3,679, we find steel area approximately 0.045, or for 12-in. centers, $0.045 \times 12 = 0.54$ sq. ins.

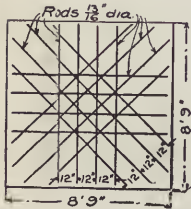

Fig. 78. — Plan of Footings 12, 13, 17 and 18.

This corresponds to a diameter of $13/16$ in. It takes 4 rods $13/16$ in. in diameter crossing each other at right angles, and 4 rods $13/16$ in. in diameter on each diagonal.

Similar calculations will give figures for the other square footings.

The above calculations are, of course, approximate, but they are safe, and are as simple as any calculations the author has seen.

Conclusion.—The mat reinforcement consists of a 6x6-in. mesh high carbon steel fabric of No. 7 and No. 11 gage wire, laid within 2 ins. of the top of the 6-in. floor, depressed under the columns to about 5 ins. below the floor.

Before excavation, sheet piling should be carefully driven along the north and east building lines, the basement columns being here moved in 12 ins. The retaining walls run from column to column, and above the sheet piling are built out to the building line. The fabric continues from the mat up within 2 ins. of the inside of the retaining wall, and to it is wired such reinforcing rods as are required to withstand the earth pressure from the adjacent property.

The first story columns are placed on the building line, by cantilevering the girders 12 ins. It will be found that the steel above calculated will take care of this cantilever action, but the author always adds two more rods at the bottom of the girders, bent at $1/3$ the span and reaching the top at each end.

The curtain walls are reinforced with fabric only and are 6 ins. thick.

Where the building ordinances permit it, the author uses a high carbon wire fabric, deducting the strength of same from the required steel area; for instance, in calculating 1st to 6th floors, we had, steel area = 0.288 sq. ins. per foot. For 4x6-in. No. 7 gage we have

$$3 \times 0.0254 = 0.0762.$$

Safe strength, 28,000 lbs. makes it equal to twice the area at 14,000 lbs., or 0.1524 sq. in. Hence the steel area required is

$$0.2880 - 0.1524 = 0.1356$$

Using $\frac{1}{2}$ -in. rods as before,

$$\frac{0.196}{0.1356} \times 12 = 17\frac{1}{4} \text{ ins. on centers,}$$

instead of $8\frac{1}{8}$ ins., and if, owing to the increased lateral continuity, we use

$$M = \frac{wl^2}{14} \text{ or } \frac{wl^2}{16},$$

still lighter steel areas will be found, and have been successfully used in carefully executed work. See Table XLV.

SEQUENCE OF OPERATIONS IN CONSTRUCTION.

While in brick, masonry or structural steel construction the engineer has to do with first-class mechanics skilled in their work, in reinforced concrete construction most of the actual placing of the work is left to laborers who are often unskilled foreigners hardly able to understand the English language. The foremen, while probably good mechanics, may have no experience in this particular branch. The engineer must therefore fortify the contractor by a very rigid and exacting specification, which is to be literally followed in every minute detail. The contractor in turn must impress the importance of the specification and the detail plans on his superintendent and foremen, and these in turn must explain and show the mechanics exactly what is wanted, and so organize their work that the same men can do the same work over and over again, until they learn it. No method of construction needs more careful organization of the work at the building site than reinforced concrete.

Clearing the Site.—The first work in any construction is generally excavation. The author has found the following a valuable rule where excavation is necessary. The site should be kept as clear of machinery as possible; boilers, engines, mixers, and even crushers, should, if practicable, be placed at the side of the building or on a suitably constructed

bridge floor or preferably in an adjacent lot leased for the purpose. This keeps the excavated premises clear of incumbrances, except large derricks arranged to reach every corner of the site, thus saving the moving of the contractor's plant. The selection of such plant depends, of course, upon the contractor's method of construction.

Lumber and Reinforcing Materials.—The contractor must plan for the delivery of materials on the premises sufficiently ahead of time to prevent any stoppage of the work. The first material needed on the premises is lumber for the forms. For a large sized job it is well to have a band saw, cross-cut saw, and a boring machine driven by a small motor for the manufacture of parts of the different forms, which may then be numbered and piled for future use in places readily accessible at that time. The reinforcing material should commence to arrive simultaneously with the lumber and be delivered in the order in which it is to be used, and numbered and placed in racks easily accessible. As soon as the excavation is ready the first forms are assembled and erected, and the reinforcement carefully placed and fastened in position.

Placing the Reinforcement.—Before depositing the concrete, the forms are swept clean and sprinkled, and a man appointed by the foreman for the purpose gives all his time to the inspection of the proper location of all reinforcement. In the placing of reinforcing material, Hennebique generally proceeds as follows: A bed of concrete is first placed in the bottoms of the beam and girder molds, upon which is laid the tension bars with the stirrups slipped under them and held in upright position by small mounds of concrete packed around their bottoms. The remaining concrete is then placed and rammed in 3-in. layers until the level of the floor slab is reached. The reinforcing rods and stirrups of the slab are then blocked up on a bed of concrete exactly as in constructing the girders. Care is taken that the stirrups are kept in contact with the tension bars and that neither is disturbed or shifted by the process of ramming.

Instead of placing the reinforcement piece by piece as herein described, the author prefers and recommends the practice of erecting the skeleton complete before any concrete is placed, as indicated in Fig. 79, which shows work at the Winton Garage, Chicago. The cut shows the built-up reinforcement of the girders in position, and the hooked rods laid into the end wall ready for concreting.

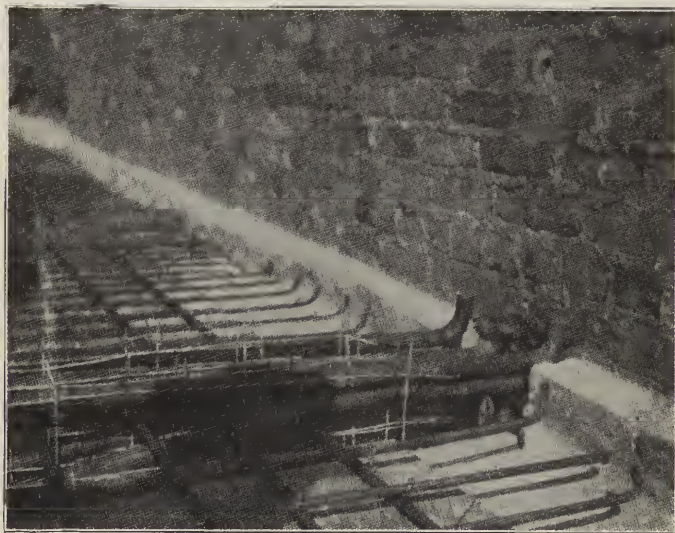

Fig. 79.—Reinforcement of Girders in Winton Garage, Chicago.

Making Concrete.—The sand, stone and cement must be located where they can be dumped from wagons, and with one handling delivered to the mixer. The distribution of the materials to the mixer must be carefully watched, as it must always be kept in mind that a building is only as strong as its weakest part and the omission of a few bags of cement in the batch would be a matter of the greatest consequence.

Delivering Concrete.—From the mixer the concrete should be delivered to the wheelbarrows, buckets, or conveyors as fast as made, and at the same time as fast as required. As the mixer is generally located stationary at one level, the delivery from the mixer to the different floors means the introduction of a vertical lift or elevator and here the concrete is either transported in barrows or buckets, which are hoisted on an elevator platform or in bulk by means of elevator buckets on an endless chain. When the concrete has arrived at its proper level, it is either wheeled by hand to the forms, or the buckets are moved by derricks, cableways or otherwise, but the work should be so arranged that there is no stop or waiting. Some process must be going on continually.

Depositing Concrete.—The different types of construction require different consistencies of concrete and the method of depositing varies accordingly. In cold weather a rather dry mixture should be employed and should be poked well around the reinforcement and carefully tamped with heavy iron tampers. In hot weather a more wet consistency can and should be used, in which case the concrete is stirred or spaded around the reinforcement and adjacent to the forms. The compacting of floor slabs is sometimes done by rolling, first by using a 3x3-ft., 350-lb. wooden roller, then a 2½x2½-ft., 500-lb. iron roller and finally a 2½x2½-ft., 700-lb. iron roller. It must always be remembered that the hardening of concrete is not a "drying-out process," as some are apt to suppose, but is a chemical action caused by the addition of water to the cement. The concrete takes its "initial set" in a short time and therefore should be deposited in place as quickly after mixing as possible.

Concreting Columns.—Column molds are often built upwards while the concreting progresses; usually, however, the form is erected complete the full height, and the concrete filled in from the top. In this case one side of the mold is left loose at the bottom so the form may be carefully inspected as to location of reinforcement and all shavings, etc.,

removed from the bottom before the concrete is poured in. Long-handled rammers or spading tools are run up and down the side of the form during the concreting to prevent air voids or exposure of aggregates.

Concreting Walls.—In Fig. 80 is shown the wall-form employed in constructing the wall of the Central Felt & Paper Co.'s factory, Long Island City, N. Y. The walls are 6 ins. thick between wall columns and carry no weight except their own, and the adjacent edges of the floor and roof slabs.

At the floor and roof levels and also at the bottom, each wall bay is reinforced as a girder.

The reinforcement of the wall consists of vertical sheets of wire fabric placed near the inner surface.

At window or door openings this fabric is folded back so as to form a U-shaped net at the side of each opening. Sheets of the same material bent to U-shape are also embedded in the wall concrete under the window sill.

Each panel of the form consists of two vertical pieces 3 ft. high and 16 ft. long. For the first course they were seated at the floor level and braced by props on both sides.

After the concrete had stood for three days the panels were loosened and raised until the lower edges were 2 ins. below the top of the concrete.

In this position they were supported by bolts running through sleeves resting on the top of the concrete and the upper edges were held by transverse boards nailed 4 ft. apart. The sleeves used consisted of pasteboard tubes, it being found that these were just as efficient and much easier to place and trim than wrought-iron pipe.

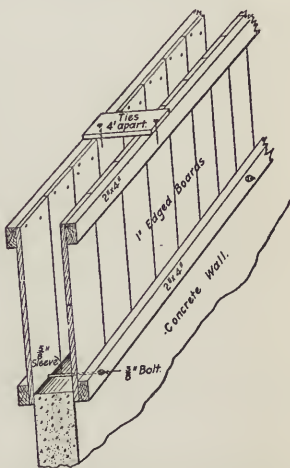

Fig. 80.—Wall Mold, Central Felt & Paper Co. Factory.

Several designs for detachable wall form ties have been devised, and used with more or less success. The simplest method seems to be either the one used at the Central Felt & Paper Co.'s factory, or simply to employ soft iron tie wire holding the outside studs together, leaving the tie wires in the concrete by clipping off the wire in taking off the forms. For walls the concrete is generally run in fairly wet and in place of tamping is usually stirred with rods, and the reinforcing fabric shaken or lightly tapped.

Joining Successive Days' Work.—When the concreting of a structure cannot be made a continuous process from start to finish, as is often the case, care must be exercised in stopping off one day's work and in joining the next day's work to the break. In no case must the concrete be stopped before the full depth of the floor has been completed over the area of section for one day's work. The joint should take place along the center line of the span for a slab or in the center of span of a girder and the joint be made fairly square but as rough as possible. Fig. 81 shows in the foreground a piece of a 2x4-in. scantling braced up for a joint in the slab work. The next day this joint is cleaned by hose and sprinkled with neat cement before depositing the concrete. Some contractors prefer the joint to be made at supports, but the author has avoided cracks by making joints where concrete on top is in compression. If the joint is made at the support, it should be made along the longitudinal center line of the girder or beam.

Protection of Concrete in Setting.—Now comes a very important point. To enable the concrete to set properly it must be kept moist. This is an item which too often is neglected and which prevents many otherwise well-designed reinforced concrete constructions from attaining the strength intended. A layer of moist sand or preferably sawdust should be spread over all horizontal surfaces and kept moist for a week or ten days, and all vertical surfaces should, after removal of forms, be kept wet by sprinkling or, if the surfaces are exposed to the sun, should be covered with canvas which

is kept wetted down by means of a hose. Such a method is illustrated by Fig. 154, under Tanks.

As before mentioned, the distribution of concrete must be so arranged as to reduce to a minimum all traffic by men and wheelbarrows over actual finished work. Fig. 81 illustrates this point, being a view of the construction of the Winton Garage in Chicago, designed and superintended by



Fig. 81.—Concreting Floors in Winton Garage, Chicago.

the author. It is clearly shown how the wheeling was done over planks laid on small horses in such manner that the finished concrete was not disturbed.

Protection Against Freezing.—Concrete work is often carried on in winter months and will freeze if precautions are not taken. The freezing retards the setting of the concrete and often completely ruins it. It is usually best to remove

any concrete known to have been frozen. Simple precautions can be taken to prevent freezing, such as heating the materials, adding less than 10 per cent of salt to the water, keeping the building heated by means of salamanders, and covering the concrete after being laid with some good insulating material, such as cement bags, straw, manure, etc.

If work must be done in cold weather the only proper method is to inclose the building in temporary walls of canvas or boards and roof it over; if necessary, cover all openings with light duck, and all floors as soon as laid, with plank panels raised some 6 ins. above the floor surface. Steam pipes can then be run into each floor from a boiler employed for the purpose. The same boiler may be used to heat the sand, stone and water and the exhaust steam may be discharged into the rooms and under the floor covering to heat them and keep the air moist. This will assist in quickly hardening the concrete during cold weather.

It is under all circumstances preferable not to continue concrete work in cold weather, as it prevents the proper wetting of the concrete while setting.

FORMS, MOLDS, CENTERING, AND FALSEWORK.

Forms, molds, and centering designate the temporary construction required to give to the concrete its shape. Falsework is generally used to designate the supports of forms, molds, and centering. In considering this subject we will use the expression "forms" to include all the items here mentioned.

Inasmuch as forms represent most of the labor entering into the cost of reinforced concrete, they should be carefully designed in the drafting room and not by rule of thumb. The best concrete contractors carefully design the forms with a view of obtaining maximum safety and economy.

Kind of Lumber.—The character of the work and the local market decide the selection of lumber. White pine should be first choice; next come spruce, fir, Norway pine or southern pine. The lumber should not be kiln-dried, but should be dried stuff. Beveled edges or tongue and groove

TABLE LIX.—AVERAGE SAFE ALLOWABLE WORKING UNIT STRESSES IN POUNDS PER SQUARE INCH.
 Recommended by the Committee on "Strength of Bridge and Trestle Timbers."
 Association of Railway Superintendents of Bridges and Buildings.

Kind of Timber.	Tension.		Compression.			Transverse.		Shearing.	
	With Grain.	Across Grain.	With Grain.		Across Grain.	Ex- treme fiber stress.	Modulus of elasticity.	With Grain.	Across Grain.
			End bear'g. under 15 diam.	Columns under 15 diam.					
	Ten.	Ten.	Five.	Five.	Four.	• Six.	Two.	Four.	Four.
Factor of Safety.									
White oak.....	1,000	200	1,400	900	500	1,000	550,000	200	1,000
White pine.....	1,700	50	1,100	700	200	700	500,000	100	500
Southern, Long-leaf, or Georgia yellow pine.....	1,200	60	1,600	1,000	350	1,200	850,000	150	1,250
Douglas, Oregon, and } yellow fir.....	1,200		1,600	1,200	300	1,100	700,000	150	
Washington fir or pine } red fir.....	1,000					800			
Northern or Short-leaf yellow pine.....	900	50	1,200	800	250	1,000	600,000	100	1,000
Red pine.....	900	50	1,200	800	200	800	600,000		
Norway pine.....	800		1,200	800	200	700	600,000		
Canadian (Ottawa) white pine.....	1,000			1,000				100	
Canadian (Ontario) red pine.....	1,000			1,000		800	700,000	100	
Spruce and Eastern fir.....	800	50	1,200	1,000	200	700	600,000	100	750
Hemlock.....	600		1,200	800	150	600	450,000	100	600
Cypress.....	600		1,200	800	200	800	450,000		
Cedar.....	800		1,200	800	200	800	350,000		400
Chestnut.....	900			1,000	250	800	500,000	150	400
California redwood.....	700			800	200	750	350,000	100	
California spruce.....				800		800	600,000		

stuff gives the best results for floor and wall forms. Table LIX gives safe working stresses for various kinds of timber. It should be borne in mind that this table is arranged for use in designing trestles, which are permanent structures, having to sustain weight not only temporarily, as in concrete falsework, but allowance is also made for the possible deterioration of the timber. In concrete molds, however, much higher values can be assumed for the stress in the lumber, since the time the timber is in place is a comparatively short time, and another fact which lessens the stresses is that concrete begins to be self-sustaining as soon as it begins to set.

Points to Consider in Design of Forms.—The design of forms must take into consideration the following points:

- (1) Cost of lumber and labor.
- (2) Size and nature of the work; whether the forms may be used over and over again, or whether the lumber in the forms should be detachable, so as to be reapplied as the work goes on.
- (3) Means of supporting forms, attention being given to initial stresses in reinforcement erected in advance and used to support the forms, such as is the case where steel skeleton structures are rapidly erected, several floors being concreted simultaneously.

Assumptions Made in the Design of Forms.—The construction of forms is considered as a temporary one; hence the stresses allowed are more liberal than they would be in permanent constructions. For the design of forms the following assumptions are made:

- (1) Concrete weighs 150 lbs. per cu. ft.
- (2) A live load representing the weight of laborers with wheelbarrows and material is taken at 75 lbs. per sq. ft.
- (3) For side pressure in vertical walls the concrete is considered as a liquid weighing 75 lbs. per cu. ft.
- (4) Allowable compression in struts runs from 600 to 1,200 lbs. per sq. in., according to the length of the strut, and for beams, 750 lbs. per sq. in. extreme transverse fibre stress is used.

(5) Deflection is calculated by the formula

$$D = \frac{3}{384} \frac{WL}{EI}$$

where D = greatest deflection in ins.

W = total load in lbs. on plank or timber

L = distance between supports in ins.

E = modulus of elasticity of lumber

I = moment of inertia of section of timber = $\frac{bh^3}{12}$ where

b = breadth, and

h = depth

The value for E may be assumed as 1,300,000 lbs. per sq. in. It should be noted that in a structure of some height where there is a repetition of the design, the falsework should be used over and over, in which case the thickness of molds is made greater than strength and stiffness require, so as to permit all to be torn down and reassembled.

Fastening of Forms.—While in the early days of reinforced concrete, metal clamps, like the Hennebique pattern, Fig. 82, were much in vogue, modern practice prefers wooden

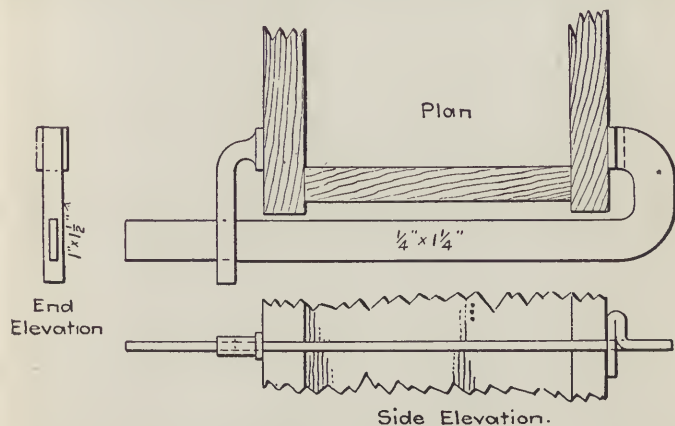

Fig. 82.—Hennebique Clamp for Girders.

bracings with wedges as the simplest and easiest obtainable appliance for beams and columns. For octagonal columns a very simple bracing is obtained by beveling the eight sides of the column so as to fit together, bracing or squaring them by means of a wooden cross inside, removable as the concrete progresses, and tied together every 2 or 3 ft. vertically on the outside by means of No. 18 annealed wire, which is loosely wrapped a couple of times around the circumference. A $\frac{7}{8}$ -in. board is inserted underneath the wire and twisted sidewise so as to tighten the wire, after which a couple of

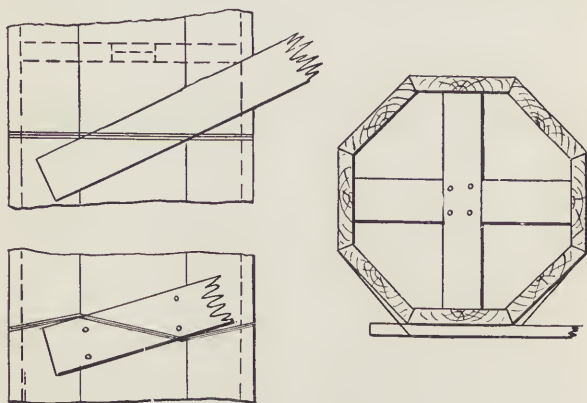

Fig. 83.—Fastening for Octagonal Column Mold.

nails are partly driven through the $\frac{7}{8}$ -in. board into the side of the octagonal form as indicated by Fig. 83. Column-sides and bottom of beam-forms should be designed so they may be independent of the slabs. Washers should be used on all bolt heads and nuts.

Joints in Forms.—For dry concrete this is not a matter of great importance, but where a wet mixture is used, poor joints permit the escape of water with cement, thus marring the appearance of the finished work by leaving holes. Where it is policy to use a wet mixture, tongued and grooved stuff

is considered advantageous. All corners in forms should be filleted, which is generally done by cutting 2x2-in. stuff diagonally or for round corners, by tacking 1½-in. hollow quarter rounds in the corners.

Spacing of Studs.—As a rule the spacing of studs for 7⁄8-in. boards is 2 ft.; for 1½-in. stuff, 3 ft. 6 ins., and for 1¾-in. stuff, 4 ft. 6 ins. The studs run from 2x4 ins. to 4x6 ins., according to the span, and 4x4 ins. and 4x6 ins. are the most common dimensions for posts. In calculating forms, particular attention is paid to deflection, even more than to strength.

Thickness of Lagging.—All material should be dressed on side and edge. The thickness varies from 7⁄8 in. to 1¾ ins., according to circumstances. The selection of the stuff also depends upon the method of handling, whether by hand or by derrick. Sides for girders and columns are generally made of 1¾-in. stuff.

Rotation in the Use of Forms.—From an economical standpoint great care should be exercised in the rotation or sequence in the removal of falsework and forms. The foreman should decide as to the next use or location of his falsework as well as his forms and remember that what he takes down first he will probably need first in the next location; hence he should not pile a lot of beam and slab forms on top of his falsework, but so distribute the same that it may be accessible. Forms should be erected in such sequence as to allow the contractor to lay out his work so as to reduce the walking over and on setting concrete, to a minimum. This is an important caution and by rights is worthy of being placed on a large sign on every job.

Alignment and Setting of Forms.—Forms are handled either by hand or by derrick, and of course should be designed accordingly. One point in setting forms and falsework is of the greatest importance and that is to see that all verticals are absolutely plumb and maintained plumb. Not only the foreman but every man on the job should be on the watchout for alignment in both directions.

During the depositing of the concrete the author has made it a practice to have two good carpenters do nothing but watch the alignment of the forms for columns, girders, beams and slabs by driving and setting the wedges or placing such shims inside the column braces as may be required. As the molds will have more or less of a sag after being filled with concrete, it is customary to give them a slight camber so as to make them absolutely horizontal when the concrete is hardened. The wedges, as a general rule, should be sharp and thin enough to stick without being tacked and the pride of every foreman should be to have his forms removable and collapsible so as to be compelled to pull as few nails as possible in shifting.

Adhesion of Concrete to Forms.—To prevent adhesion of concrete to the forms, a coat of crude oil or soft soap and water is considered the most practicable, but if the forms are to be left on until the concrete is hard, there is little danger of the concrete sticking to them, if they are thoroughly wet with water before the concrete is laid.

After removing the forms they should be brushed thoroughly with a stiff brush to remove all loose material, at any rate while the forms are new. It is found that crude oil need be applied but once or twice, as it seems the pores of the wood are filled thereby, and also by cement, which prevents old forms from sticking to the concrete. The careful cleaning of forms is essential if a smooth, firm face is desired.

Time to Remove Forms.—This is a matter of great importance, and lack of attention to this item has caused most of the disastrous accidents to reinforced concrete. The time for removal depends on the following considerations:

- (1)—The consistency of the concrete, whether wet or dry.
- (2)—The quantity of concrete in the members considered.
- (3)—The temperature.
- (4)—The humidity of the air.

As a fair example, it may be suggested that for walls in mass work, one to three days should be allowed, or until the concrete will bear the pressure of the thumb without indenta-

tion. For thin walls in summer, two days, in cool weather five days; slabs in summer six days, in cool weather two weeks. Beams and girders in long-span slabs in summer ten days or two weeks, in cool weather three weeks to one month. Column forms in summer four days, in winter six days, providing the girders are shored up to prevent appreciable weight on the columns. Arches of small size one week, large arches with heavy dead load one month. These

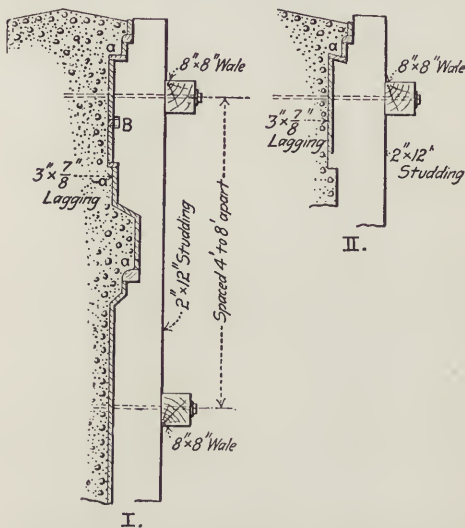

Fig. 84.—Arrangement of Studding and Lagging to Provide for Swelling.

are but suggestions, as the removal of forms should be left entirely to the judgment of the experienced engineer in charge.

For face work, arrangement should be made so the molds can be withdrawn without tearing the corners of ornaments.

Mr. Douglas* uses a method indicated by Fig. 84, where

* Engineering News, Jan. 24, 1907.

he provides a loose strip of lagging at *B*, so it can be pulled back to a recess in the stud after 6 to 12 hours to allow for shrinkage of concrete and swelling of forms.

An exaggerated illustration of the effect of the swelling of lagging on continuous studding is shown at II, Fig. 84

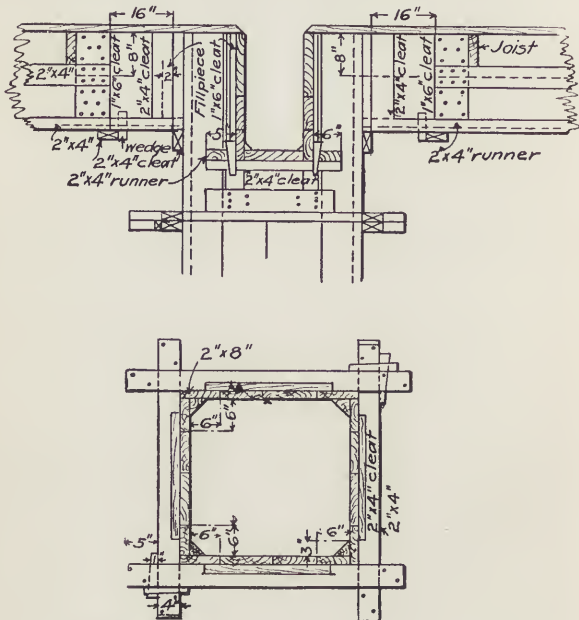

Fig. 85.—Forms for Girders, Beams, Slabs and Columns.

Column and Floor Forms.—Numerous constructions of column and floor forms are used. The construction shown by Fig. 85 is a representative example. This form was designed by Mr. R. A. Cummings.

Forms in Combined Steel and Concrete Construction.—Where concrete floors rest on structural steel or where structural steel is erected first, as a skeleton and the members so

located as to form the tension part of the reinforced concrete construction, the forms should be supported on the temporary steel beams and girders so as to give them a certain stress during the placing of the concrete, which otherwise would act as an initial stress in the steel, if the false-work were supported from below.

Separately Molded Members.—For some time in Europe, and recently in this country, attention has been turned to the possibility of a building construction of columns, girders and slabs molded separately and erected similarly to steel or timber construction. Whatever may be said in other respects of this type of construction in comparison with monolithic construction in place, it certainly has the advantage of reducing the cost of form work. Thus several one-story warehouses built for the Bush Terminal Co. of Brooklyn have reinforced concrete columns, girders and roof slabs cast on the ground and then erected. Mr. Goodrich, the designer, describes the work substantially as follows: "For molds for columns cast on one side, only three pieces were needed in place of four. This effects a saving of 25 per cent in materials for molds, besides doing away with clamps, bolts and braces. Another advantage obtained by these column forms, shared also by girder-forms, was that the side boards could be removed after 24 or at the most 48 hours and used again two or three times during the interval, while they must have been left in place if the molding had been done in place. This alone saves 50 per cent in materials for forms, as only the narrow bottom boards were needed in any great numbers. A much greater saving was made in the centers for the roof slabs. The concrete ground floor was laid as soon as the columns and girders had been erected. On this flat surface ordinary building paper was spread and the roof slabs marked out by narrow strips of wood of a height just equal to the desired thickness of the slab. The reinforcing rods were then placed and the concrete deposited."

Frames and trims for partition and wall openings are separately molded in permanent galvanized iron forms, as shown

in Fig. 86, and this method entirely does away with the combustible wooden trim usually employed in building construction.

Eliminating the Use of Forms.—Inasmuch as forms represent more or less waste of material, considerable attention has been given to reinforced concrete construction in which forms are reduced to a minimum. Thus in constructing the interior columns of a factory building erected by the Bush Terminal Co. of Brooklyn cylindrical forms of cinder concrete 1½ ins. thick cast in proper molds were set end on end to the proper height to form a mold for the column concrete.

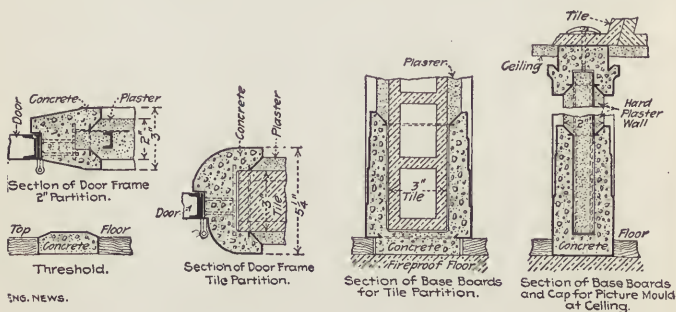

Fig. 86.—Separately Molded Details for Doors, Windows and Partitions.

Spiral reinforcement was adopted for the columns and was molded into the shell, so that the placing of the column form also placed the column reinforcement. There was gained at once by this scheme of form work, a fireproofing for the column, the placing of the form and reinforcement in one operation by unskilled laborers and the elimination of labor for removal of forms. As for the shells themselves, their cost was certainly not greater and was probably less than would have been for cylindrical molds in wood.

In the Wiederholdt system of reinforced concrete construction, no forms whatever are used. Fig. 87 shows the

system as applied to wall construction. By the use of hollow tile blocks of special shape, thin shells of fire clay or cement tile are used as molds and form the exterior surface. The vertical steel bars are embedded in the foundation in the usual way, and the tiles are laid between them with horizontal bars at suitable intervals, after which the concrete is placed, the tiling and concrete being carried up as the work progresses. This system is also adapted to the construction of grain and other storage buildings, and especially for smoke stacks.

Small Tools for Mixing, Conveying and Ramming.—As reinforced concrete construction has developed, the tools used have changed considerably. They are becoming standardized as the importance of this phase of the work is being recog-

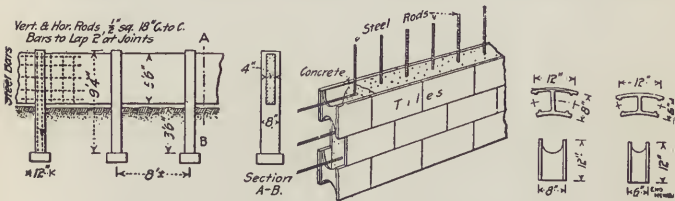

Fig. 87.—Wall Construction, Wiederholdt System.

nized. While formerly the same tools that were used for brick and mortar were used for concrete work, now special tools, adapted to the peculiarities of concrete work, are a great advantage.

Instead of the old-fashioned wooden brick and mortar barrows formerly in use, most contractors are now using iron wheel barrows, Fig. 88, or, for larger work, a Ransome concrete cart, Fig. 89. The latter is built entirely of steel, and as it has large wheels is very easy to move about, enabling one man to move several times as much material as he can handle with a wheel barrow. This form of cart is easy to dump and the concrete is not readily spilled over the side of the bowl. This saves time and material. It is stated

by the manufacturers that the cost of moving concrete with an iron push cart is $1\frac{1}{4}$ cts. per cu. yd. per 100 ft. of haul.

Square pointed shovels are generally employed and for mixing and handling the materials size No. 3 is considered the best.



Fig. 88.—Iron Wheelbarrow for Handling Concrete.

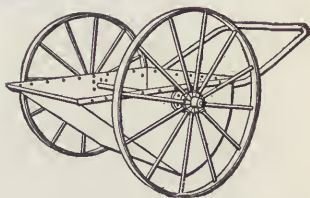

Fig. 89.—Ransome Concrete Cart.

A simple measuring box is shown by Fig. 90. It is bottomless and 8 to 10 ins. high, and of a size to suit the mixture. Thus, if in a 1-6 mixture the proportions 1-2-4 give

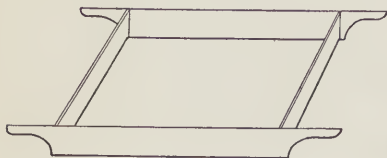

Fig. 90.—Measuring Box for Aggregates.

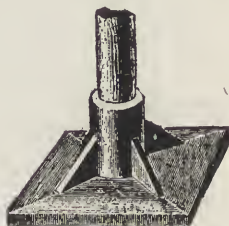

Fig. 91.—Cast Iron Rammer for Dry Concrete.

the greatest density, the box would be 8 ins. deep and 2 ft. $7\frac{1}{2}$ ins. x 4 ft. This box should be filled once with sand and twice with broken stone, each time being struck off level.

Sometimes hoes are used for mixing material and give good results, particularly if one of the men is a regular mortar mixer.

Rammers are used for compacting the materials. For dry mixtures a flat rammer, usually cast iron with 7x7 ins. base, as shown by Fig. 91, is used. These generally weigh from 6 to 8 lbs., while for wet concrete a wooden rammer, Fig. 92, is used to cut and compact the material. For thin walls a tool having a long flat steel plate mounted on a handle will be found of use. For large work pneumatic rammers built on the principle of pneumatic riveting machines have been used. Other tools, such as mixers and crushers, have been referred to before and the different contracting equipment companies issue very complete catalogs from which selections can be made.

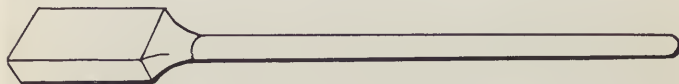

Fig. 92.—Wooden Rammer for Wet Concrete.

FINISHING CONCRETE SURFACES.

Since the character of a concrete structure is judged largely by the appearance of the exterior, the finishing of such surfaces becomes very important. In the first place, concrete is a comparatively new building material, different from iron, wood, or tile, and should be recognized as such by giving it a distinct concrete appearance. To the author's mind, imitation of other materials is out of place in concrete structures. The manner of finishing must be governed by the size and class of the structure and the style of architectural decoration. The facility with which concrete lends itself to ornamentation enables the choice of a style of architecture with features that otherwise might be considered very expensive. On the whole, simplicity and plainness in general outlines should mark concrete construction.

Types of Finish.—There are five main types of finish for concrete:

- (1) Leaving the concrete as it is when the forms are removed.
- (2) Hammer dressing or tooling.
- (3) Using a mortar facing or plastering.
- (4) Using special concrete mixtures.
- (5) Washing away the cement to expose the aggregates.

Hair Cracks.—Smooth concrete surfaces often show cracks generally caused by using a wet concrete, in which the excess of water carries to the surface and deposits a coating of very fine cement which sets and contracts at a different rate from the underlying concrete. These cracks can be eliminated by covering the concrete with wet sand or sawdust, which is kept well sprinkled for some time after the placing of the concrete. Too rich a mixture, or a surface mixture richer than the body concrete, will also cause hair cracks. If impracticable to cover with sawdust, the surface showing cracks may be scrubbed thoroughly with a wire brush or a cement brick to remove the cement film.

Mortar Facing.—To produce a smooth surface finish on concrete a mortar facing is often used, varying in thickness from 1 in. to 3 ins. To place this facing a steel plate is inserted in the form and held away from it by means of angle irons from 1 in. to 1½ ins. wide, depending upon the thickness of facing required. The concrete is put into the form back of the plate and the mortar into the narrow space between the form and the plate, and the plate is carefully withdrawn.

Another method of obtaining a smooth surface is to use a very wet concrete and throw it violently against the mold, so that the aggregates rebound leaving in effect a mortar facing. This is, however, not to be recommended for fine work, as the molds are apt to be indented and the alignment impaired.

Using Special Dry Mixture.—This method has been used extensively for park buildings in Chicago and is described by Mr. Linn White as follows:

“The method consists in using for the exposed surfaces the walls of concrete composed of one part of cement and three parts of fine limestone screenings and three parts of crushed limestone known as the $\frac{1}{4}$ -in. size. This was then mixed quite dry, so no mortar was flushed to the surface, and well rammed in wooden forms. It was not spaded next the form, and was too dry to cause any flushing of mortar. The imprints of joints between the boards were hardly noticed, and no efflorescence can appear on the surface on account of the dryness of the mix and the porosity of the surface. The same finish has been successfully used for retaining walls, arch bridges, fence posts, walls enclosing service yards, etc. A dry, rich mix with finely crushed stone has been found especially suited to another condition where a sound, smooth surface was particularly difficult to secure, namely, for the under-water portion of a sea wall on Lake Michigan. It was mixed very dry and dumped in sunken boxes, joined end to end, made fairly water-tight, but from which water was not excluded. With a finely crushed stone, a sound, smooth surface was obtained when the sides of the boxes were removed where it was manifestly impossible to plaster or grout the surface and where spading a mix of coarser stone would obviously wash away the cement.”

Bringing Aggregates Into Relief.—This gives a finish which, to the author's mind, is superior to a smooth surface, since with it variations in color, efflorescence, hair cracks, and other superficial blemishes are practically removed. The simplest method of bringing out this rough effect is to scrub the concrete with brushes while it is green, as soon as the forms are removed. In cases where the forms must be left until concrete is hard, the cement may be removed by the application of a weak acid solution, which afterwards should be neutralized with an alkaline solution and then well washed with water. Rubbing with a small block of wood or sand-

stone or scrubbing with a stiff wire brush also removes a hard cement coating. When the forms are removed at the right time, three or four passages of an ordinary scrubbing brush with plenty of water is all that is required and a laborer can wash about 100 sq. ft. in an hour where the work is easily accessible.

Tooling.—Tooled surfaces are obtained on concrete similarly as for stone. When the concrete is hardened, the surface may be bush-hammered or treated in any other manner. In these cases the forms may be of rough lumber. Tooling the surface generally costs from 3 to 10 cts. per sq. ft., according to quantity and outfit. The Citizens' National Bank of Los Angeles, Cal., was finished with bush-hammering at a cost of $1\frac{1}{2}$ cts. per sq. ft., common laborers at \$2 a day doing the work.

Plastering Concrete.—When plaster is to be applied to concrete the concrete should be left quite rough, so as to form a clinch. There should be no difficulty in causing the layers to adhere to each other if properly applied. The concrete should be well sprinkled before the plaster is laid, as the interior concrete, being dry, will otherwise, absorb moisture and prevent adhesion. In every case the plaster must be rubbed and tooled hard against the concrete, and while surfacing more water should be applied by means of a sprinkling brush.

Painting and Varnishing.—Cement floors can be painted and varnished like wood if first the surface is primed with a solution that will fill the pores and stop capillary action. A solution of hydrofluoric acid has been used for this purpose to good advantage.

WATERPROOFING.

With the increased use of concrete and reinforced concrete, waterproofing is daily becoming of greater importance. A number of patented preparations have been invented and put on the market to serve the purpose of making a structure waterproof, either by application on the outside of the wall or on the inside, and in some instances by adding chem-

ical substances to the cement, so as to form a gelatinous substance, which prevents the absorption of water and still have no harmful effect on the crystallizing of the cement. In the author's opinion, waterproofing is as yet in its infancy, and owing to the increasing demand, great attention is now being given to the matter by chemists and waterproofing engineers. At present we must realize that the simplest means of reducing permeability in concrete is to increase its density, both in the selection and application of aggregates and in compressing the surface after finishing by vigorous tooling or rubbing. Impurities in water through seepage assist in making tanks water-tight by filling the pores, and numerous tanks and pipes have been made water-tight without the addition of any particular preparation to the material or on the surface. When, however, we notice the leaking or dripping from subways, tunnels, or concrete coverings, or suffer from wet or damp cellars or basements, we must realize that lack of proper waterproofing is a menace to public health. To reduce the personal equation to a minimum it is the safest to apply a waterproofing layer of felt, tar, asphalt or pitch, as the case may be, and where it will do the most good. Inasmuch as waterproofing is a specialty and requires skilled mechanics for its proper application, and, furthermore, inasmuch as the different waterproofing companies generally provide their own waterproofing compounds, it is hardly within the province of this book to go further into details than to offer the following advice in the specifications:

(1) Design the structure so as not to make application of waterproofing impossible for lack of space or operation.

(2) No waterproofing must be done under a lower temperature than 25° F.

(3) Waterproofing must be done only by experienced and skilled laborers.

(4) Watch the waterproofing during and after the application, and inspect the work during progress.

(5) Do not depend upon guarantees.

(6) Do not stick to a standard specification, but make a specification to suit local circumstances.

CHAPTER III.

THE DESIGN AND CONSTRUCTION OF BRIDGES. THE ELASTIC THEORY OF ARCHES SIMPLIFIED.*

Introduction.—Formerly, when stresses in plain masonry arches were computed, the engineer was satisfied when the line of resistance was within the middle third of the arch ring, and this is satisfactory for symmetrical loading and heavy voussoir arches, where the ratio of the live load to the dead load is a small one—and here the graphostatic method was considered sufficient, even though arbitrary.

But with the advent of reinforced concrete it has become necessary to resort to the elastic theory to properly determine the stresses under symmetrical and unequal loadings for comparatively light structures, where temperature stresses also become very important.

The application of this theory has not come into general use among engineers, notwithstanding the fact that experiments undertaken by the Austrian Association of Architects and Engineers have demonstrated that arches can be considered elastic curved beams and computed accordingly.

While we admit that even the elastic theory does not give mathematically correct results, owing to the questionable rigidity of the abutments, a marked improvement is found as compared with the usual assumption of three points through which the pressure line is supposed to pass.

The designing engineer must be qualified to judge as to the correctness of these assumptions.

The method here given will in an extremely simple way permit of ascertaining the intensities of stresses in any part of the arch ring, whether it be due to live or to dead loads—

*From a translation by Mr. C. W. Hoffman, C. E., of Mr. Th. Landsberg's article in "Zeitschrift des Vereins für Deutscher Ingenieure," Dec. 14, 1901.

and will also lead to formulas whereby the arch ring may be dimensioned in advance of the statical examination.

An arch fixed at both ends is statically threefold indeterminate—and the three unknowns which cannot be determined by the static theory can be found by the elastic theory.

Preliminary Examination of Reactions Caused by a Concentrated Load.—As a concentrated load G , Fig. 93 moves over the arch, it produces in each position two reactions, R_A and R_B , which must be in equilibrium with the concentrated load G .

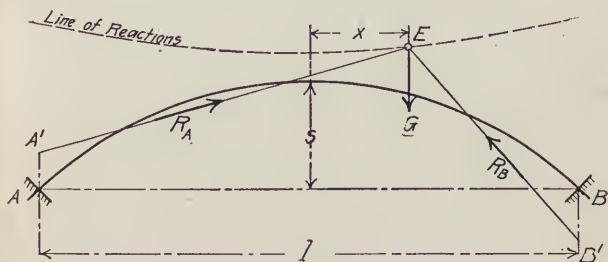

Fig. 93.

The point E in which the two reactions intersect the load G describes a line, the form of which depends upon the curve of the arch ring. This line will herein be called the "line of reactions." During the progress of the moving load G the two reactions will envelop curves, which will be called "involute of reactions." The line of reactions and the involute of reactions being known, the location, direction and magnitude of the reactions can readily be found for any given position of the concentrated load G .

We will, however, show that we can dispense with the involute of reactions.

If the line of reactions is known, the reactions can be determined when for the reactions other points, A' and B' , Fig. 93, are established, through which the reactions must pass—as we know that both reactions pass through point E , which in turn is located by the positions of load G .

Therefore lines passing through E and through A' and B' , respectively, represent the reactions.

We will next show how to quickly determine the direction, location and magnitude of the reactions for any given concentrated load G .

To simplify matters, we will assume the arch to be a flat parabola, though the results can, without hesitation, be applied to flat circular arches, or other curves by a slight modification of the formulas.

Let l = span or horizontal projection of neutral axis of arch between its intersections with the skewback or springing line

s = the rise of the neutral axis.

The arch is assumed to be symmetrical, with the springing lines on same level. Then we have from Fig. 94:

(1) The line of reactions is a straight line at a distance of $\frac{8}{15}s$ above and parallel to AB .

(2) If a second line is drawn at a distance of $\frac{2}{3}s$ above and parallel to AB intersecting the perpendiculars through the neutral axis at the skewbacks at A_0 and B_0 , then the lefthand reaction, due to a concentrated load at a distance x to the right from the center intersects the perpendicular through A at a distance v below A_0 B_0 —and the righthand reaction intersects the perpendicular through B at a distance v' below A_0 B_0 ; or, geometrically expressed:

$$v = \frac{8}{15}s \frac{l}{l+2x}$$

$$v' = \frac{8}{15}s \frac{l}{l-2x}$$

or

$$\frac{v}{\frac{8}{15}s} = \frac{l}{l+2x} = \frac{\frac{l}{2}}{\frac{l}{2} + x}$$

The following simple construction results (Fig. 95):

Draw line A_0B_0 at a distance of $\frac{2}{3}s$ above and parallel to AB and a parallel II at a distance $\frac{8}{15}s$ below A_0B_0 .

Producing the load line G at a distance x from the center will cut off the length $D'D'' = \frac{8}{15}s$ between the parallel lines A_0B_0 and AB .

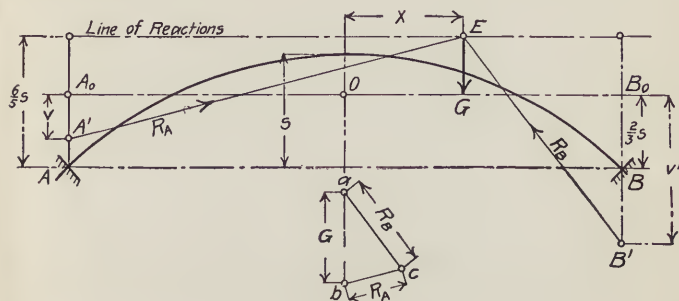

Fig. 94.

A line connecting A_0 with D'' intersects the perpendicular through the crown at L and we have

$$\frac{OL}{\frac{l}{2}} = \frac{\frac{8}{15}s}{\frac{l}{2} + x}$$

$$OL = \frac{8}{15}s \frac{l}{(l+2x)} = v$$

A horizontal line through L will intersect the vertical through A and A' , which passes through the lefthand reaction.

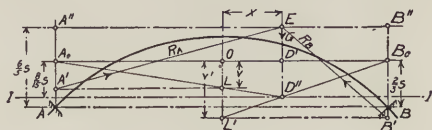

Fig. 95.

The construction of v' and B' is done in the same manner, as is indicated in Fig. 95.

Connecting these points with E gives us the reactions in regard to location and direction. Their magnitude is easily found by means of a force polygon.

If (Fig. 94) $ab =$ concentrated load at E , then

$$bc = R_A \text{ and } ca = R_B.$$

Similarly, lines from the points of intersection A' and B' , are drawn for different positions of the concentrated load and the reactions determined. It is sufficient to find these intersections on one side only and transfer them for symmetrical loads to the opposite side.

Successive Steps in the Design of an Arch.—In computing an arch we proceed as follows:

- (1) Establish the arch ring.
- (2) Locate point O in the perpendicular through the crown at a distance $\frac{2}{3}s$ above AB .
- (3) Draw the line A_0B_0 through O parallel to AB .
- (4) Draw a horizontal line II at a distance $\frac{1}{15}s$ below A_0B_0 or $\frac{2}{15}s$ above AB .
- (5) Subdivide the span AB in a number of equal parts.
- (6) Establish the points of intersection A' and B' of the reactions with the perpendiculars through A and B for all positions of load G . (Fig. 95.)
- (7) Draw the line of reactions $A''B''$ a distance $\frac{2}{3}s$ above AB .
- (8) Lay off the reactions as to location and direction for all positions of load G by connecting the points A' and B' with the points E on the line of reactions.
- (9) Determine graphically the magnitude of reactions.

This construction is indicated in Fig. 96, except that for the sake of simplicity the lines for finding v and v' have been omitted.

Line of Pressure Due to Dead Load.—Determine weights

$$G_5 \quad G_4 \quad G_3 \dots \dots \dots G_{IV} \quad G_V$$

for each point of loading as usual (Fig. 96) and for each of these loads find the left and righthand reaction.

The point of intersection L' of the extreme sides of this polygon is the point through which the resulting reaction, which is parallel to am , must pass.

Combining R_A with $G_3 G_4, \dots$ the line of resistance and the line of pressure can be drawn, as shown in Fig. 96.

It will be noted that this construction is free from arbitrary assumptions—and we can easily check the location of point m , as the vertical component of am must be equal to one-half of the total vertical load.

Line of Pressure for the Critical Condition of Loading.—We will demonstrate later how to determine the critical position of the live load for any section; for the present be it assumed that these positions are known.

Then determine the amount of live load which under most unfavorable conditions will come upon each point of loading—that is, a load Le , where L equals live load per lin. ft. and e the distance between assumed points of loading.

This load is then consecutively placed on all points of loading and the resulting reactions are determined as in Fig. 96 and combined to form the left (right) hand reaction polygon; then draw the equilibrium polygon with the arbitrary pole O . In Fig. 97 $a b c \dots m$ represents the reaction polygon and O_2 the pole.

The equilibrium polygon is marked $V'', IV'', III'', II'', I'', 1'', 2'', 3'', 4'', 5''$. With these two polygons the corresponding line of pressure for any condition of loading can be determined.

Let it be assumed arbitrarily that in order to produce maximum stress in Joint 2 the points I, II, III, IV, V would have to be loaded. The loads I, II, III, IV, V produce a reaction on the lefthand side, the magnitude and direction of which are represented by fm in the reaction polygon. The location is determined by the condition that the resultant

$$fm = R_{I-V}$$

must pass through the intersection of those sides of the equilibrium polygon which border the forces R_I and R_V that is, point α .

Combining R_{I-V} with the reaction caused by the dead load

in Joint 2 gives us the total resultant due to this condition of loading and acting at Joint 2.

This force was determined in regard to location, direction and magnitude under the head of line of pressure due to dead loads.

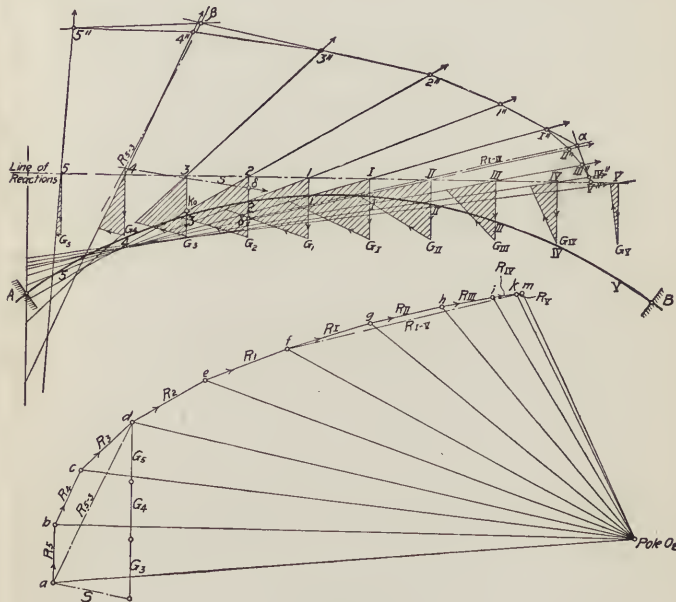

Fig. 97.

Assuming now that the maximum stress in Joint 2 would occur when points 5, 4 and 3 were loaded, the procedure would be similar to that just illustrated.

The lefthand reaction R_{5-3} is first determined as to location, direction and magnitude, and combined with the loads to the left of Joint 2, *i. e.*, with the loads at points 5, 4, 3. The resultant R intersects Joint 2 at δ , and is finally to be combined with the reaction due to the dead load.

It is clear that by this method the critical position of the line of pressure and its deviation from the neutral axis, as well as the intensity of stress for any section of the arch ring can be found, provided the most unfavorable condition of loading is found.

Critical Condition of Loading for a Given Section.—The reactions due to a moving concentrated load at once disclose the most unfavorable condition of loading, so that the involute of reactions may be dispensed with.

Considering the points near the intrados of a section, then any force in this section passing above the middle third produces tension at the intrados; any force in the section passing below the upper limit of the middle third produces compression at the intrados.

For points of loading at the right of the assumed section under a moving concentrated load, the lefthand reaction is determinate and for points of loading at the left of the section, we must consider the righthand reaction.

We recommend that both right and left reactions be drawn.

However, if the reactions for but one side are drawn, the opposite reactions may be examined in a section located symmetrically with the one under investigation—letting the reactions act there.

In Fig. 97 the lefthand reaction at section 3 for a concentrated load at point 2 accidentally passes through K_0 , the upper limit of the middle third, but the reactions due to a load in 1, *I*, *II*, *III*, *V*, intersect below the middle third, producing compression near the intrados at section 3, while a load at point 3 produces tension at these points.

In order to find the stress produced by a load in 4 and 5 (at the left of 3) we investigate section *III* with reference to the effect of a load at *IV* and *V*. A load at 4 and 5 will have the same effect on section *III*.

We see that loads at *IV* and *V* produce tension at the intrados of section *III* because the reactions R_{IV} and R_V pass the section far above the middle third.

Maximum tension in section 3 therefore is found by loading points 5, 4 and 3, maximum compression is found by loading points 2, 1, I, II.....V, while a load at point 2 produces a stress equal to zero.

It is sufficient to consider the points on one side of a section as fully loaded and the points on the other side as not loaded.

Proof of the Correctness of Locating Points A' and B'.— If, according to Muller-Breslau (*Die neueren Methoden der festigkeitslehre*, 2d edition, p. 115), the two forces X and Y , acting at O and the moment Z be considered as the three unknown quantities, then X can be found from the condition that the algebraic sum of the moments of X and Y and of the moment Z with the point A as a center must be equal to the resisting moment at the springing or skewback A , Fig. 98.

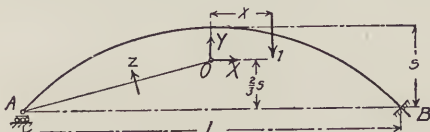

Fig. 98.

The origin O must be so chosen that in each of the three equations for elastic arch all unknowns are eliminated but one. With this in view the point O must represent the center of gravity of the neutral axis, and X and Y must coincide with the two principal axes of the arch center line. If the latter is a flat parabola with a rise $=s$ and a span $=l$, the point O will be located at a distance $\frac{3}{8}s$ above AB .

Assuming a load at a distance x to the right of the center, we may write the three following equations:

$$\left. \begin{aligned} X &= \frac{15}{64sl^3} (l^2 - 4x^2)^2 \\ Y &= -\frac{(l^2 - 4x^2)x}{2l^3} \\ Z &= \frac{l^2 - 4x^2}{8l} \end{aligned} \right\} \dots\dots\dots (25)$$

By means of Formulas (25) the influence lines for the three unknown quantities, X , Y and Z , can easily be drawn. For two positions of the load symmetrical with respect to the vertical axis, X and Y have equal values. Y changes its sign with x , hence symmetrical positions of Y only change the sign.

Uniform load equal on both sides of the center makes $Y = 0$.

In order to replace X , Y and Z by their resultant, we combine the resultant of X and Y with the moment Z , which causes a parallel shifting of the resultant of X and Y . Since its direction is given by

$$\tan \delta = \frac{Y}{X}$$

it will be sufficient to establish one point through which it must pass.

Assuming that the resultant intersects the vertical center line at S , a distance m below O , then the algebraic sum of the static moments of X , Y and Z must equal zero; that is, the following equation for m must be satisfied:

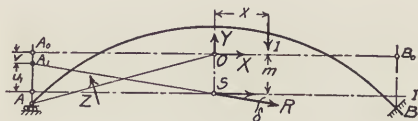

Fig. 99.

$$Xm - Z = 0, \text{ whence } m = \frac{Z}{X}$$

Substituting the values of Formulas (25) for X and Z ,

$$m = \frac{8sl^2}{15(l^2 - 4x^2)}$$

The resultant passing through S forms the angle δ with the horizontal, and if the negative sign of Y is taken care of by laying it off downwards, we have

$$\tan \delta = \frac{Y}{X} = \frac{32sx}{15(l^2 - 4x^2)}$$

and with the relations in Fig. 99,

$$u = \frac{l}{2} \tan \delta = \frac{16slx}{15(l^2 - 4x^2)}$$

$$v = m - u = \frac{8sl^2}{15(l^2 - 4x^2)} - \frac{16slx}{15(l^2 - 4x^2)} = \frac{8sl}{15(l + 2x)}$$

At point A_1 the resultant of X , Y and Z is combined with the vertical component of the left hand abutment reaction.

The reaction we find (Fig. 100), therefore, must pass through A_1 . When the load advances to the left of the center line we obtain similarly,

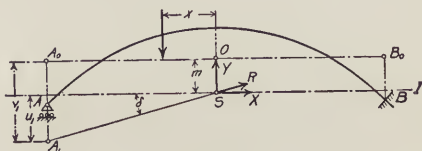

Fig. 100.

$$m = \frac{8sl^2}{15(l^2 - 4x^2)}$$

$$u_1 = \frac{16slx}{15(l^2 - 4x^2)}$$

Particular notice must be given to the fact that u_1 is positive when laid off downwards while u is positive when laid off upwards.

By addition we obtain

$$v_1 = m + u_1 = \frac{8sl}{15(l - 2x)}$$

The values for v_1 hold good for loads at the right of the center for righthand reactions, and the values v for righthand reactions when the load is at the lefthand side from the center.

Approximate Analysis of Dead Load.—In the following investigation we assume the upper limit of the dead load diagram to be a straight line, as shown in Fig. 101, the in-

trados to form a parabola, the rise of the arch to be s and the height of the dead load diagram at center equal to r .

At any point a distance x from the center the height of the dead load diagram is

$$z = r + \frac{4sx^2}{l^2}$$

or with a weight per unit of D the load over dx is

$$Dzdx = D \left(r + \frac{4sx^2}{l^2} \right) dx$$

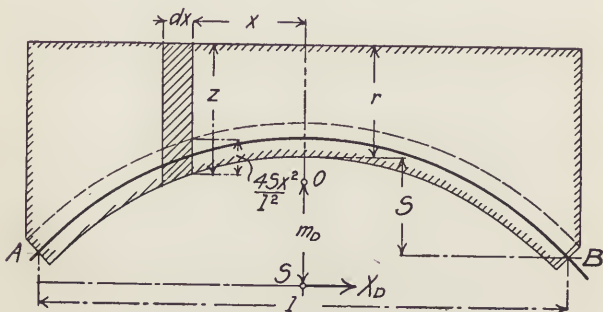

Fig. 101.

For this condition of loading Formulas (25) furnish the following values:

$$\left. \begin{aligned} X &= \frac{2 \times 15}{64sl^3} D \int_0^{\frac{l}{2}} (l^2 - 4x^2)^2 \left(r + \frac{4sx^2}{l^2} \right) dx \\ Y &= 0 \\ Z &= \frac{2D}{8l} \int_0^{\frac{l}{2}} (l^2 - 4x^2) \left(r + \frac{4sx^2}{l^2} \right) dx \end{aligned} \right\} \dots (26)$$

or when integrating,

$$\left. \begin{aligned} X_D &= \frac{Dl^2}{56s} (7r + s) \\ Y_D &= 0 \\ Z_D &= \frac{Dl^2}{60} (5r + s) \end{aligned} \right\} \dots\dots\dots (27)$$

Since $Y_D = 0$, the resultant from X_D and Z_D is acting horizontally, and is of the magnitude X_D , intersecting the vertical center line at a point m_D below O .

We have

$$X_D m_D - Z_D = 0, \text{ or } m_D = \frac{Z_D}{X_D}$$

Referring to Formulas (27), we get

$$m_D = \frac{1}{15} s \frac{5 + \frac{s}{r}}{7 + \frac{s}{r}}$$

X_D always intersects the vertical through the springing line at a distance m_D below O .

The resultant of all forces acting at the left (or right) of the crown intersects the vertical center line at a distance above O , which is equal to n and subject to the following conditions (Fig. 102):

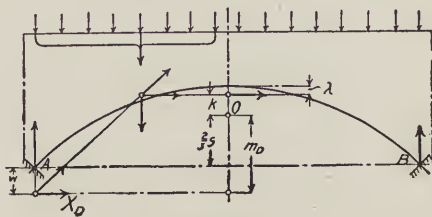

Fig. 102.

$$A \frac{l}{2} - X_D (m_D + n) - \int_0^{\frac{l}{2}} D z x dx =$$

$$\int_0^{\frac{l}{2}} D \left(r + 4 \frac{s x^2}{l^2} \right) \frac{l}{2} dx - \frac{D l^2}{56 s} (7r + s) \left[n + \frac{1}{15} s \frac{(5r + s)}{(7r + s)} \right] -$$

$$D \int_0^{\frac{l}{2}} \left(r + \frac{4 s x^2}{l^2} \right) x dx = 0$$

$$n = \frac{7}{30} s \left(\frac{10r + s}{7r + s} \right)$$

The point of intersection between the resultant and the center line is located at a distance λ below the neutral axis at the crown, and we have

$$\lambda = \frac{s}{3} - n = \frac{10s}{30} - \frac{7s}{30} \frac{(10r + s)}{(7r + s)}$$

$$= \frac{s}{30} \left(10 - 7 \frac{10 + \frac{s}{r}}{7 + \frac{s}{r}} \right)$$

The abutment reaction intersects the vertical through the springing at a distance w below the axis AB , and we have

$$w = m_D - \frac{2}{3} s \text{ or}$$

$$w = \frac{s}{15} \left(14 \frac{5 + \frac{s}{r}}{7 + \frac{s}{r}} - 10 \right)$$

The intercepts between the neutral axis and the lines of pressure are, at the crown, downward,

$$\lambda = \frac{s}{30} \left(10 - 7 \frac{10 + \frac{s}{r}}{7 + \frac{s}{r}} \right)$$

at the springing, downwards,

$$w = \frac{s}{15} \left(14 \frac{5 + \frac{s}{r}}{7 + \frac{s}{r}} - 10 \right)$$

TABLE LX.—VALUES OF λ AND w FOR VARIOUS VALUES OF $\frac{s}{r}$.

$\frac{s}{r}$	1	1.5	2	2.5	3	4
λ	0.0125s	0.018s	0.02s	0.026s	0.03s	0.036s
w	0.033s	0.047s	0.06s	0.067s	0.07s	0.093s

With these three points, the location of the line of pressure and the intensities of stress on any part of the arch ring are established.

Thickness of Arch Ring at Crown and Springing.—The course of investigation is as follows:

The condition of loading which is most unfavorable at the crown is determined, and as the line of pressure due to the dead load deviates downwards, it is obvious that such position of the live load as will make the pressure line deviate still further is especially unfavorable. For a given load this position of the live load can be easily determined by drawing a tangent to the involute of reactions passing through the upper limit of the middle third of the ring at the crown (Fig. 103). Their intersections L' and L'' with the line of reactions indicate the points to which the live loads

must advance. All loads at the left and right of points L' and L'' produce compression in the parts of the crown near the intrados.

In order to obtain the maximum stresses this space must be completely covered by the live load.

For approximate calculations we may assume that $L'L''$ represents the middle third of the span and the two outer thirds are supposed to be under a live load L per lin. ft.

Then we have, according to Formulas (26),

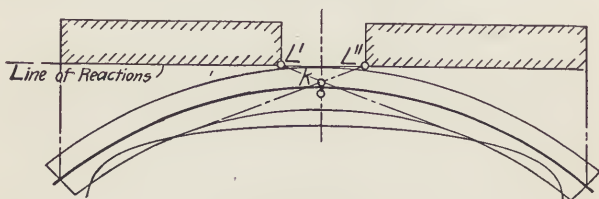

Fig. 103.

$$\left. \begin{aligned} X_L &= \frac{2 \times 15}{64sl^3} L \int_{\frac{l}{6}}^{\frac{l}{2}} (l^2 - 4x^2)^2 dx = \frac{2Ll^2}{64s} \text{ (approximately)} \\ Y_L &= 0 \\ Z_L &= \frac{2L}{8l} \int_{\frac{l}{6}}^{\frac{l}{2}} (l^2 - 4x^2) dx = \frac{Ll^2}{24} \text{ (approximately)} \end{aligned} \right\} (28)$$

The intersection of X , Y , Z with the vertical center line is located m_L below O (Fig. 104), and we have

$$\begin{aligned} X_L m_L - Z_L &= 0 \\ m_L &= \frac{Ll^2}{24} \cdot \frac{64s}{3Ll^2} = \frac{8s}{9} \end{aligned}$$

The resultant X_L intersects the vertical axis at a distance of

$$m_L + \frac{s}{3} = \frac{11s}{9}$$

The resultant of the forces acting on one side of the vertical axis intersects same at a point located a distance t below the crown, t being found as follows:

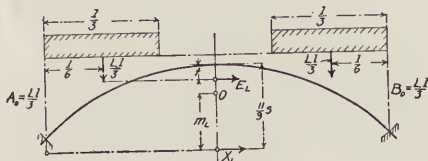

Fig. 104.

$$\frac{Ll}{3} \cdot \frac{l}{6} - X_L \left(\frac{1}{9}s - t \right) = 0$$

$$X_L = \frac{3Ll^2}{64s} \text{ or}$$

$$\frac{1}{9}s - t = \frac{Ll^2}{18} \cdot \frac{64s}{3Ll^2} = \frac{32}{27}s$$

$$t = s \left(\frac{1}{9} - \frac{32}{27} \right) = \frac{s}{27}$$

The resultant of all forces on one side of the vertical axis—dead load and live load—intersects the joint at the crown at a point T (Fig. 105). The location of point T is as follows:

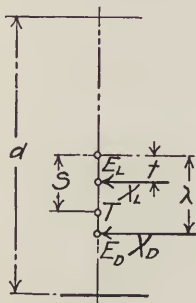

Fig. 105.

$$(X_D + X_L) S = X_D \lambda + X_L t \text{ or}$$

$$S = \frac{X_D \lambda + X_L t}{X_D + X_L} = \frac{\lambda + \frac{X_L t}{X_D}}{1 + \frac{X_L}{X_D}}$$

S is the maximum deviation at the crown and is figured positive downwards.

If we simplify matters by making

$$\frac{X_L}{X_D} = \frac{C}{s} \text{ we have } C = \frac{21}{8 \left(\frac{7r}{s} + 1 \right)} \frac{L}{D}$$

and

$$S = \frac{\lambda + \frac{C}{s} \frac{s}{27}}{1 + \frac{C}{s}} = \frac{\lambda + \frac{C}{27}}{1 + \frac{C}{s}} = \frac{s \left(\lambda = \frac{C}{27} \right)}{s + C}$$

or approximately

$$S' = \lambda + \frac{C}{27}$$

For $\frac{L}{D} = \frac{100}{150} = 0.667.$

These values are shown in Table LXI.

TABLE LXI.—VALUES OF C , λ AND S' FOR VARIOUS VALUES OF $\frac{s}{r}$.

$\frac{s}{r}$	1	1.5	2	2.5	3	4
C	0.492	0.772	0.875	1.036	1.180	1.432
λ	0.0125 s	0.018 s	0.02 s	0.026 s	0.03 s	0.036 s
S'	0.0125 s + 0.0182	0.018 s + 0.0286	0.02 s + 0.0324	0.026 s + 0.0384	0.03 s + 0.0437	0.036 s + 0.0530

The maximum intensity of stress S_m at the crown occurs at a deviation S of the resultants from the neutral axis. If the thickness of crown = d , we have

$$S_m = \frac{X_{(D+L)}}{1d} = \frac{X_{(D+L)} 6S}{1d^2}$$

where

$$X_{(D+L)} = X_D + X_L$$

If K denotes the maximum permissible unit stress, we have the following equation for d ,

$$d^2 - X_{(D+L)} \frac{d}{K} = X_{(D+L)} \frac{6S}{K}$$

$$d = \frac{X_{(D+L)}}{2K} \left[1 + \sqrt{1 + \frac{24SK}{X_{(D+L)}}} \right]$$

hence,

$$X_{(D+L)} = \frac{Dl^2}{56s} (7r + s) + \frac{3}{64} \frac{Ll^2}{s}$$

$$= \frac{Dl^2}{8s} \left(r + \frac{s}{7} + \frac{3}{8} \frac{L}{D} \right)$$

If we assume

$$r + \frac{s}{7} + \frac{3}{8} \frac{L}{D} = q$$

we have

$$X_{(D+L)} = \frac{Dl^2}{8s} q$$

and

$$d = \frac{qDl^2}{16Ks} \left[1 + \sqrt{1 + \frac{24S8Ks}{qDl^2}} \right]$$

$$= \frac{qDl^2}{16Ks} \left[1 + \sqrt{1 + \frac{192SKs}{qDl^2}} \right] \dots\dots\dots (29)$$

For convenience we will here repeat the notation in above formula:

d = thickness of crown in feet.

D = weight per cu. ft. of masonry in lbs.

l = span of neutral axis in ft.

s = rise of neutral axis in ft.

K = permissible pressure on masonry in lbs. per sq. ft.

r = height at crown of dead load diagram in ft. (Fig. 101).

L = live load in lbs. per sq. ft.

Example.—Find thickness of crown in parabolic arch for the following conditions:

$$l = 60, s = 6, r = 3, L = 100 \text{ lbs. } D = 150 \text{ lbs.}$$

We have then $\frac{s}{r} = \frac{6}{3} = 2, K = 144 \times 400 = 57,600 \text{ lbs. sq. ft.}$

hence

$$S = 0.02s + 0.0325 = 0.1525$$

$$q = 3 + \frac{6}{7} + \frac{3}{8} \times \frac{100}{150} = 4.11.$$

From Formula (29),

$$d = \frac{4.11 \times 150 \times 60^2}{16 \times 57,600 \times 6} \left(1 + \sqrt{1 + \frac{192 \times 0.1525 \times 57,600 \times 6}{4.11 \times 150 \times 60^2}} \right)$$

= 1.334 ft. for a plain concrete arch.

Thickness of Arch Ring on Both Sides of Crown Down to the Skewback.—A quick and practical method of finding the thickness of the arch at any point after finding the crown thickness is as follows (Fig. 106):

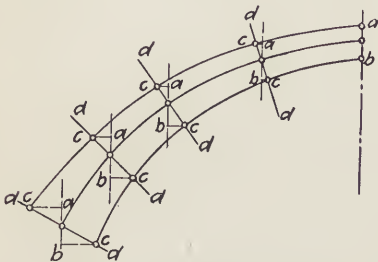

Fig. 106. — Diagram Showing Method of Finding Thickness of an Arch.

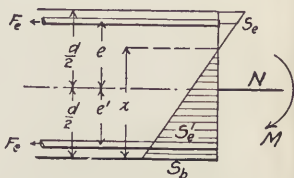

Fig. 107.—Diagram Showing Location of Neutral Axis.

(1) Draw radial lines dd intersecting the neutral axis at right angles, and perpendicular lines through the points of intersection.

(2) On these perpendicular lines lay off the crown thickness ab and produce horizontally to the radial lines dd , cutting them at points c . Then the distances cc represent the arch thickness at the various points.

Location of Neutral Axis.—According to Prof. E. Morsch in "Der Eisenbetonbau," 1906, we have the following equation for the location of the neutral axis, p being the percentage of reinforcement on each side of the neutral axis (Fig. 107):

$$x^3 - 3x^2 \left(\frac{d}{2} - \frac{M}{N} \right) + 12x \frac{M}{N} n \frac{F_e}{b} - 6 \frac{nF_e}{b} \left(\frac{M}{N} d + 2e^2 \right) = 0 \dots (30)$$

Making $e = 0.42d$ and $F_e = pbd$, we have

$$\frac{M}{Nd} = \frac{-x^3 + \frac{3}{2}dx^2 + 31.75pd^3}{3dx^2 + 180pd^2x - 90.pd^3} \dots \dots \dots (31)$$

Here $N = X_{(D+L)}$ and $M = X_{(D+L)} S$

hence

$$\frac{M}{Nd} = \frac{S}{d}$$

The curves, Fig. 108, are plotted for values of $x = 0.1d, 0.2d, 0.3d$, etc., as abscissas and $\frac{S}{d}$ for different percentages of reinforcement $p = 0.001, p = 0.002, p = 0.003$, etc., as ordinates.

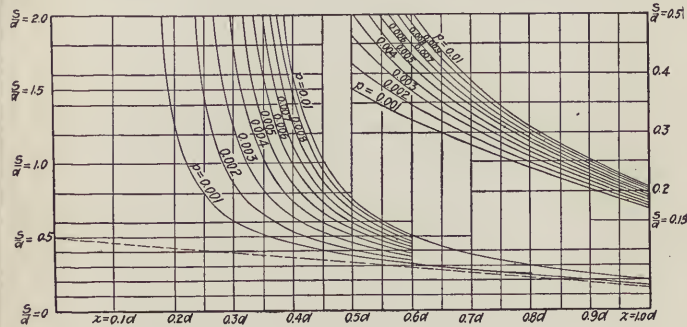

Fig. 108.—Diagram of Curves for Different Values of P .

When x is found either by trial from Formula (41) or taken from the diagram, Fig. 108, the different stresses are found as follows (Fig. 107):

$$S_b = \frac{2Nx}{bx^2 + 2pbdn(2x - d)} \dots\dots\dots (32)$$

$$S_o = nS_b \frac{e + \frac{d}{2} - x}{x} = 15S_b \frac{0.92d - x}{x} \dots\dots\dots (33)$$

$$S_e' = 15S_b \frac{x - 0.08d}{x} \dots\dots\dots (34)$$

where $\frac{E_s}{E_c} = 15$

Thermal Stresses.—According to Prof. Cain, the thermal stresses in a reinforced concrete arch ring may be expressed as follows:

$$H = \frac{E_c l e t}{\sum (y^2) - m \sum (y)} \frac{I_c - nI_s}{S} \dots\dots\dots (35)$$

where

H = the horizontal thrust at the crown due to change of the length of the arch line with change of temperature,

t = degrees change in temperature,

e = expansion per degree.

$$m = \frac{\sum_o^a (y)}{a}$$

a = number of segments, s , in the arch ring,

l = span,

y = the ordinates of s .

The normal force at any joint will be the component of H perpendicular to that joint, and the bending moment will be

$$M = H(y - m)$$

Buel & Hill give, p. 136 of Reinforced Concrete,

$$H = \frac{DE_c (I_c + nI_s)}{s \sum (xy)} \dots\dots\dots (36)$$

where D = deflection at crown due to change of length of arch ring with changes of temperature and H the corresponding horizontal thrust.

By tabulating the values xy for all the segments s of the ring from one springing to the other, the solution is quite simple, since

$$\frac{E_c (I_c + nI_s)}{s} \text{ is constant.}$$

Prof. Cain* suggests that an increase of steel should be used in arches to satisfy the condition at any critical point, that all the bending moments due to load and temperature should be borne entirely by the steel at some stress under the elastic limit, say 20,000 lbs.

EXAMPLE OF AN ARCH DESIGNED ACCORDING TO THE ELASTIC THEORY.

Assumptions.—In a bridge of 84 ft. span, having a rise of 10 ft. 6 ins., we have a live load of 250 lbs. per sq. ft., a 6-in. earth fill at the crown and a 12-in. pavement. Thickness of arch ring is assumed to be 14 ins. at the crown and 20 ins. at the springing. To find r we have, reduced to concrete weight:

- 1.167 ft. concrete at 150 lbs. per cu. ft. = 1.167
- 6 in. earth fill at 120 lbs. per cu. ft. = 0.4
- 12 in. pavement at 150 lbs. per cu. ft. = 1.0

$$r = 2.567 \text{ ft.}$$

- $l = 84 \text{ ft.}$
- $s = 10.5 \text{ ft.}$
- $r = 2.567 \text{ ft.}$

Constructing the Arch Ring.—Assuming a parabolic arch, the ordinates are conveniently found by using the formula:

$$y = \frac{4s}{l^2} x(l-x) \dots\dots\dots (37)$$

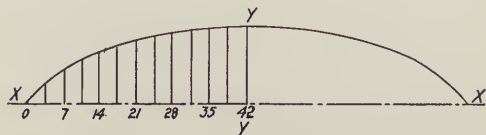

Fig. 109.—Parabolic Arch-Ring for 84-Ft. Arch.

* Theory of Concrete Steel Arches (p. 79).

One-half the span is divided into 12 equal parts, each 3.5 ft. long, as shown in Fig. 109. The values for y are shown in Table LXII. The ordinates y of the parabola are checked by their differences as shown, the second difference being a constant.

TABLE LXII.—ORDINATES OF PARABOLA WITH VARIOUS VALUES FOR x .

Values of x .	Values of y .	First difference	Second difference.
$x = 3.5$	$y = \frac{4 \times 10.5}{84^2} 3.5 (84 - 3.5) = 1.677$		
		1.531	
$x = 7.$	$y = \frac{1}{168} 7 (84 - 7) = 3.208$		0.146
		1.385	
$x = 10.5$	$y = \frac{1}{168} 10.5 (84 - 10.5) = 4.593$		0.145
		1.240	
$x = 14.$	$y = \frac{1}{168} 14 (84 - 14) = 5.833$		0.146
		1.094	
$x = 17.5$	$y = \frac{1}{168} 17.5 (84 - 17.5) = 6.927$		0.146
		0.948	
$x = 21.$	$y = \frac{1}{168} 21 (84 - 21) = 7.875$		0.146
		0.802	
$x = 24.5$	$y = \frac{1}{168} 24.5 (84 - 24.5) = 8.677$		0.146
		0.656	
$x = 28.$	$y = \frac{1}{168} 28 (84 - 28) = 9.333$		0.145
		0.511	
$x = 31.5$	$y = \frac{1}{168} 31.5 (84 - 31.5) = 9.844$		0.147
		0.364	
$x = 35.$	$y = \frac{1}{168} 35 (84 - 35) = 10.208$		0.145
		0.219	
$x = 38.5$	$y = \frac{1}{168} 38.5 (84 - 38.5) = 10.427$		0.146
		0.073	
$x = 42.$	$y = \frac{1}{168} 42 (84 - 42) = 10.5$		

Dead Load Diagram.—Next the dead load ordinates are reduced to concrete weights by multiplying by $\frac{120}{130}$ and the dead load line drawn. The lengths of the center lines of the panels are as follows:

$$G_0 = 10 \text{ ft. } 2 \text{ ins.}$$

$$G_5 = 7 \text{ ft. } 8 \text{ ins.}$$

$$G_4 = 5 \text{ ft. } 9 \text{ ins.}$$

$$G_3 = 4 \text{ ft. } 3 \text{ ins.}$$

$$G_2 = 3 \text{ ft. } 3 \text{ ins.}$$

$$G_1 = 2 \text{ ft. } 9 \text{ ins.}$$

The panel loads are found as follows:

$$G_0 = 10\frac{1}{6} \times 7 \times 150 = 10,700$$

$$G_5 = 7\frac{2}{3} \times 1050 = 8,000$$

$$G_4 = 5\frac{3}{4} \times 1050 = 6,000$$

$$G_3 = 4\frac{1}{4} \times 1050 = 4,500$$

$$G_2 = 3\frac{1}{4} \times 1050 = 3,400$$

$$G_1 = 2\frac{3}{4} \times 1050 = 2,900$$

Total dead load on half span = 35,500 lbs.

We have $s = 10.5$, hence $\frac{2}{3}s = 7$ ft. and $\frac{8}{15}s = 5.6$ ft., locating lines $A_0 B_0$, $I-I$ and $A'' B''$ in Fig. 110. The line $A'' B''$ incidentally coincides with the reduced load line. The force triangles are next drawn, combining each two reactions with the panel loads, and the reaction polygon is plotted and checked by finding its vertical ordinate equal to 35,500 lbs. or the half span dead load.

The pressure line is next transferred to the arch from the equilibrium polygon, and we find that for the dead load alone, the pressure line deviates considerably from the center line of the arch, which therefore in practice would be modified to coincide more closely with the line of pressure. With the adoption of a new center line, the same calculations would have to be repeated. In the present example, however, the original center line has been adhered to.

The rays $O-6$ $O-5$ $O-1$, in Fig. 110, represent the forces acting at joints 6, 5 0 measured in the scale of forces. The

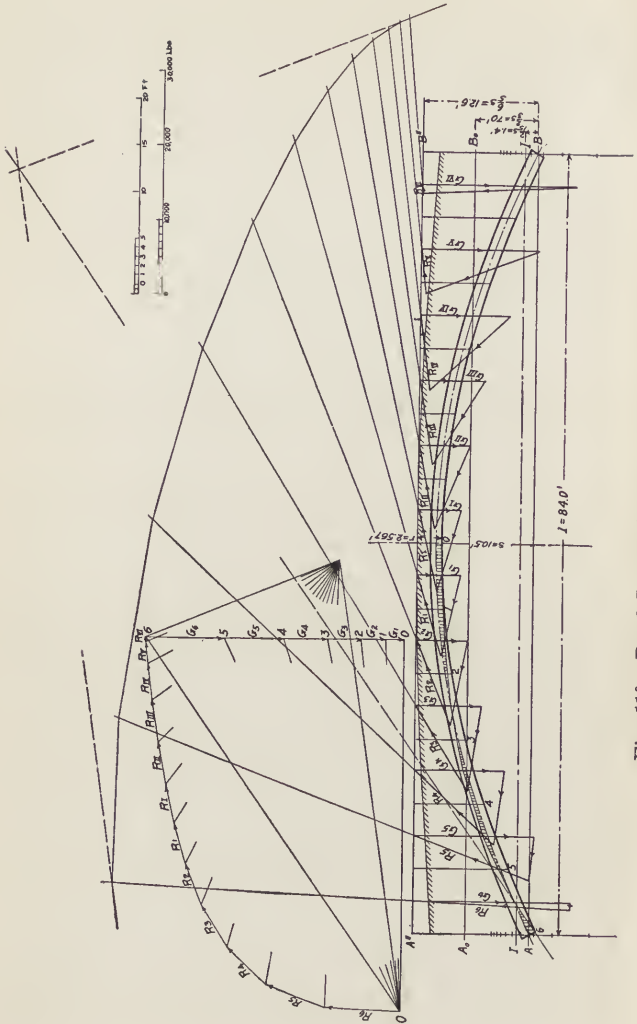

Fig. 110.—Dead Load Diagram for 84-Ft. Arch.

intercepts between the line of pressure and the center line of the arch are their levers measured perpendicular to the center line and in the dimension scale of inches.

It must be noted that the forces acting at the joints when taken from the force polygon will not intersect the joints at right angles. To obtain the normal forces N_D we must multiply the polygon forces by the cosine of the angle which they form with the perpendicular to the joints. This is done simply by projecting them graphically.

These normal forces N_D , their levers S and the corresponding moments all due to dead load, are found in table LXIII, where they will be combined with the moments due to live load in order to find the maximum.

Live Load Diagram.—The live load was assumed to be 250 lbs. per sq. ft., hence the load for a panel 3.5 ft. in length and 1 ft. depth is $250 \times 3.5 \times 1 = 875$ lbs.

Three different positions of loading will be considered in this example, namely:

- (1) Arch completely covered with live load.
- (2) Arch one-half covered with live load.
- (3) One-third arch from each end covered with live load.

(1) The right and left hand reactions for a concentrated moving load are first determined and combined to form the reaction polygon, and then the line of pressure drawn exactly as described for dead load.

The values of N_L (normal pressure at joints due to live loads) and their levers at the several joints are scaled off from the diagram, Fig. 111, and their values recorded in Table LXIII, together with the resulting moments.

The line of pressure is symmetrical about the center and has been plotted for one-half of the arch only.

(2) When the arch is covered with live load over one-half the span only the forces $G_0 \dots G_1$ are acting. The resultant reaction R_{0-1} due to this condition of loading passes through point C , which is the intersection of the sides 6 and 0 in the equilibrium polygon. With the direction and location of the left

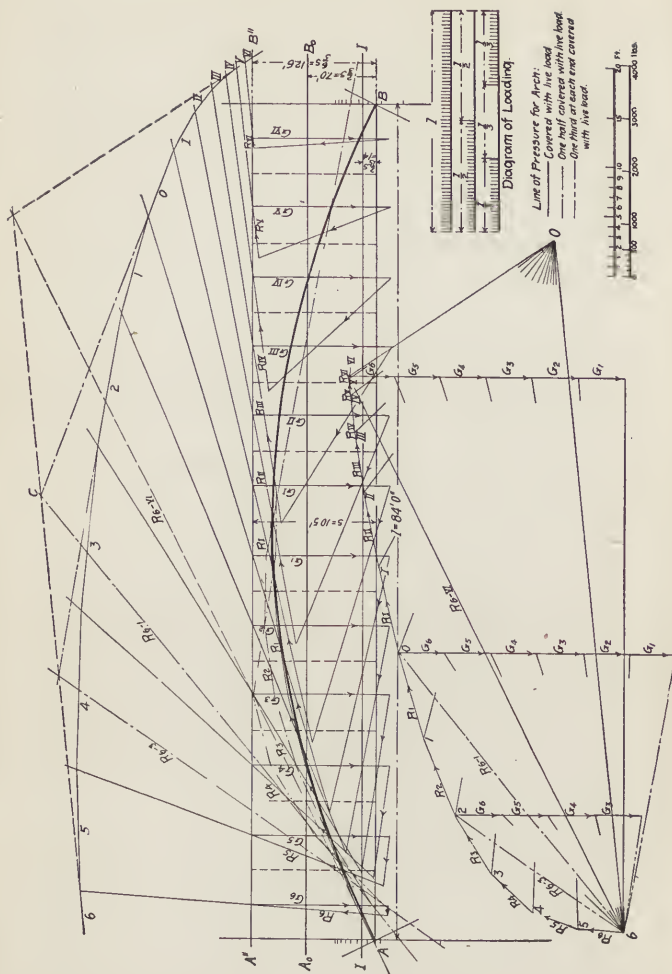

Fig. 111.—Live Load Diagram for 84-Ft. Arch.

hand reaction given, the line of pressure due to this condition of loading is easily drawn as shown in the live load diagram, Fig. 111.

(3) The line of pressure for the arch when covered with live load on the two outer thirds is found when the loads G_2 G_3 G_4 G_5 and G_{III} G_{IV} G_V G_{VI} are acting. The construction is similar to the one described and the line of pressure is symmetrical about the center of the arch, therefore only one-half is drawn in the diagram. The resulting normal forces and their levers are again scaled off and with their corresponding moments plotted in Table LXIII.

Maximum Fiber Stresses.—An examination of Table LXIII readily gives the maximum moments due to the four conditions of loading at any joint, and when added they will give the maximum at the joint in question. These maximum figures are underlined in the tables.

It will be noticed that the moments due to dead load are by far the greatest, while the moments due to full live load over the entire arch do not produce maximum stresses in any joint.

From Table LXIII we determine the fiber stresses.

The percentage of reinforcement at the crown is assumed as $p = 1$ per cent $= 0.01$ for extrados and 1 per cent for the intrados. The same size of reinforcement is maintained throughout the arch, hence the percentage at the springing is

$$p = 1 \text{ per cent.} \times \frac{11}{20} = 0.007$$

The stresses produced in each joint we have learned are due to a normal force N and a moment M , and they are figured under the usual assumption that the stress, and consequently the deformation in any fiber, is directly proportional to its distance from the neutral axis, so that a section which is plane before bending remains plane after bending. The distance x of the

TABLE LXIII.—DEAD AND LIVE LOADS AT JOINTS OF ARCH.

Joint.	Dead Load.		Live Load, Entire Span.		Live Load, $\frac{1}{2}$ Span.		Live Load, $\frac{1}{3}$ Span.		Maximum.		Max. fiber Stress. lbs. per sq. in.	
	N_D lbs.	S in.	N_L lbs.	S in.	N_L	S in.	N_L	S in.	N	M		
		M_D		M_L		M_L		M_L		M_L		
6	56,000	+9	11,600	-2	5,900	+22	129,800	2,500	+41	102,500	61,900	623,800
5	54,000	-2	11,300	-2.5	5,700	+6	34,200	2,400	+6	14,400		
4	53,000	-5	11,000	-2.5	5,500	-7	38,500	2,300	-24	55,200	55,330	320,200
3	52,000	-2	10,800	-2	5,400	-15.5	88,700	2,250	-41	92,250		
2	51,000	+1.5	10,600	-1.5	5,300	-18	95,400	2,230	-30	66,900		
1	50,500	+4	10,500	-1	5,250	-12	63,000	2,230	-6	13,380		
Ctr.	50,000	+5	10,400	-0.5	5,200	0	2,230	+3	6,690	52,230	256,690
I	50,500	+4	10,500	-1	5,250	+12	63,000	2,230	-6	13,380		
II	51,000	+1.5	10,600	-1.5	5,250	+17	89,250	2,230	-30	66,900		
III	52,000	-2	10,800	-2	5,250	+16	84,000	2,250	-41	92,250		
IV	53,000	-5	11,000	-2.5	5,250	+6	31,500	2,300	-24	55,200		
V	54,000	-2	11,300	-2.5	5,250	-8.5	44,675	2,400	+6	14,400		
VI	56,000	+9	11,600	-2	5,250	-31	162,750	2,500	+41	102,500	58,500	596,500

neutral axis from the compressed fiber is found by Formula (30), which for the sake of convenience we write

$$x^3 + Ax^2 + Bx + C = 0 \dots\dots\dots (38)$$

where $A = -3\left(\frac{d}{2} - \frac{M}{N}\right) \dots\dots\dots (39)$

$$B = 12\frac{M}{N}npd \dots\dots\dots (40)$$

$$C = -6npd\left(\frac{M}{N}d + 2e^2\right) \dots\dots\dots (41)$$

We solve x by trial, or for $n = 15$ it may be taken direct from Fig. 108, and inserted in Formulas (32), (33) and (34), where

S = compression in extreme fiber of concrete in lbs. per sq. in.

S_e = compression in steel in lbs. per sq. in.

S_e' = tension in steel in lbs. per sq. in.

As before stated, the moments in Table LXIII, and therefore the unit stresses, could be considerably reduced if the line of pressure found for dead load had been chosen for a new arch ring.

A spandrel construction would also reduce the dead load stresses to a considerable extent.

A diagram like Fig. 108 can readily be prepared for $n = 20$ instead of $n = 15$.

Moments, Stresses, etc., at the Crown.—

$M = 256,690$ inch lbs.

$N = 52,230$ lbs.

$d = 14$ ins.

$n = 20$

$p = 0.01$

$e = 0.42d$

Substituting in Formulas (39), (40) and (41),

$$A = -3\left(\frac{d}{2} - \frac{M}{N}\right) = -3\left(\frac{14}{2} - \frac{256690}{52230}\right) = -6.27$$

$$B = 12\frac{M}{N}npd = 12\frac{256690}{52230}20 \times 0.01 \times 14 = 165.0$$

$$C = -6npd \left(\frac{M}{N}d + 2e^2 \right) =$$

$$-6 \times 20 \times 0.01 \times 14 \left[\frac{256690}{52230} 14 + 2(0.42 \times 14)^2 \right] = -2314.7$$

Hence we have, substituting in Formula (38),

$$x^3 - 6.27x^2 + 165x - 2314.7 = 0$$

which gives

$$x = 10.8$$

(Using Fig. 108 for $n = 15$, we would have

$$S = \frac{M}{N} = 4.91, \quad \frac{S}{d} = \frac{4.91}{14} = 0.35 \text{ and } x = 0.74d = 10.36)$$

Substituting in Formulas (32), (33) and (34),

$$S_b = \frac{2Nx}{bx^2 + 2pbdn(2x-d)} = \frac{2 \times 52,230 \times 10.8}{12 \times 10.8^2 + 2 \times 0.01 \times 12 \times 14 \times 20(2 \times 10.8 - 14)}$$

$$= 591 \text{ lbs. per sq. in.}$$

$$S_e = nS_b \frac{0.92d - x}{x} = 20 \times 591 \frac{.92 \times 14 - 10.8}{10.8} = 2269 \text{ lbs. per sq. in.}$$

$$S_e' = nS_b \frac{x - 0.08d}{x} = 20 \times 591 \frac{10.8 - 0.08 \times 14}{10.8} = 10,591 \text{ lbs. per}$$

sq. in.

Moments, Stresses, etc., at the Springing.—

$$M = 623,800 \text{ inch lbs.}$$

$$N = 61,900 \text{ lbs.}$$

$$d = 20 \text{ ins.}$$

$$n = 20$$

$$p = \frac{14}{20} \times 0.01 = 0.007.$$

Hence

$$A = -3 \left(\frac{20}{2} - \frac{623800}{61900} \right) = +0.23$$

$$B = 12 \left(\frac{623800}{61900} 20 \times 0.007 \times 20 \right) = 338.6.$$

$$C = -6 \times 20 \times 0.007 \times 20 \left(\frac{623800}{61900} 20 + 2 \times 8.4^2 \right) = -5757.7$$

$$x^3 + 0.23x^2 + 338.6x - 5757.7 = 0$$

from which

$$x = 11.9$$

(Using Fig. 108 for $n = 15$, we would have

$$S = \frac{M}{N} = 10.08, \quad \frac{S}{d} = \frac{10.08}{20} = 0.5 \text{ and } x = 0.565d = 11.3 \text{ ins.})$$

Substituting as before, we have

$$S_b = \frac{2 \times 61900 \times 11.9}{12 \times 11.9^2 + 2 \times 0.007 \times 12 \times 20 \times 20(2 \times 11.9 - 20)} = 754 \text{ lbs.,}$$

per sq. in.

$$S_o = 20 \times 754 \frac{.92 \times 20 - 11.9}{11.9} = 8,234 \text{ lbs. per sq. in.}$$

$$S_o' = 20 \times 754 \frac{11.9 - 0.08 \times 20}{11.9} = 13,044 \text{ lbs. per sq. in.}$$

Moments, Stresses, etc., at Joint 4.—

$$M = 320,200$$

$$N = 55,300$$

$$d = 18$$

$$p = \frac{14}{18} \times 0.01 = 0.00778$$

$$n = 20$$

$$A = -9.63$$

$$B = 194.4$$

$$C = -3671.1$$

$$x^3 - 9.63x^2 + 194.4x - 3671.1 = 0$$

which gives $x = 14.2$

(Using Fig. 108 for $n = 15$, we would have

$$S = \frac{M}{N} = 5.79, \quad \frac{S}{d} = \frac{5.79}{18} = 0.322 \text{ and } x = 0.757d = 13.6 \text{ ins.})$$

Therefore

$$S_b = \frac{2 \times 55300 \times 14.2}{12 \times 14.2^2 + 2 \times 0.00778 \times 12 \times 18 \times 20(2 \times 14.2 - 18)} = 504 \text{ lbs.}$$

per sq. in.

$$S_o = 20 \times 504 \frac{0.92 \times 18 - 14.2}{14.2} = 1675 \text{ lbs. per sq. in.}$$

$$S_o' = 20 \times 504 \frac{14.2 - 0.08 \times 18}{14.2} = 9058 \text{ lbs. per sq. in.}$$

CONSTRUCTION.

The methods employed in bridge construction vary with the design and the type of bridge. Bridges are classified as flat girder spans and arches. Flat girder spans are similar to girders and floor slabs, and are particularly used for bridges of small span and light traffic.

Classification of Arch Bridges.—Arch bridges are far more numerous than girder bridges, especially in the United States. Arches may be classified as follows:

(1) Plain arches with spandrel walls, where the roadbed rests on the backfilling or on masonry not statically connected with the arch. These arches are reinforced by a double net of plain round rods (Monier system), by bent beams, or by latticed steel arches (Melan system).

(2) Structures in which the arch and the floor constructions are statically connected, used in Europe under the name of the Wuensch system.

(3) Bridges with ribbed arches, as first used in the Hennebique system.

In all three classes a saving in dead load is effected by placing cross walls or columns on top of the arches for the support of floor beams and slabs or floor arches. Hooped columns with cross girders, beams and slabs are also used to save materials and dead loads.

Construction of Arch Centering.—The centering employed for a concrete arch is similar to that used for a masonry arch, except that in the former the lagging must be made smooth, so as to give the exact shape to the concrete and so constructed that the concrete will not adhere to it. The adhesion of the concrete to the lagging would mar the smoothness of the finished arch, and might cause difficulty in striking the centers. This last item is of more serious consequence than a possible roughness in the cases where the bridge is to be given a pebble-dash or other rough finish. To prevent the concrete from adhering and to obtain a smooth surface, the lagging is dressed smooth and covered with cloth or

paper. Soap or oil are used to diminish the tendency to adhesion. Where centering is to remain in place for a long period, however, it is found that there is very little liability that the concrete will adhere to the wood.

As in masonry construction, arch centers for concrete must be rigid to prevent any settlement of the concrete. Since timber is not absolutely rigid, but is apt to settle, the rise of the centering is made slightly greater than the rise designed for the arch. Mr. Edwin Thacher provides for an additional rise in the centering of one eight-hundredth of the span.

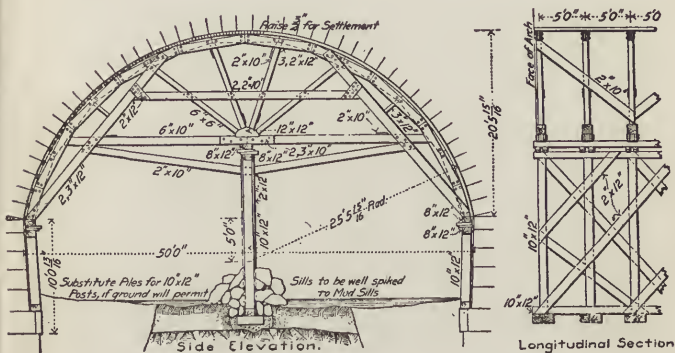

Fig. 112.—Center for 50-Ft. Arch.

Examples of Centering for Two 50-Ft. Arches.—Two forms of centering for 50-ft. arches are shown in Figs. 112 and 113, the latter being erected without support between the abutments.

Centering for the Pollasky Bridge.—Fig. 114 shows the centering for a bridge at Pollasky, Calif. There are ten 75-ft. arch spans. Six sets of false work were used for the bridge, and were moved from span to span until the work was completed. Each center was carried on five bents of

8x12-in. posts having 6x12-in. caps. Just below the caps each longitudinal line of posts was connected by a pair of

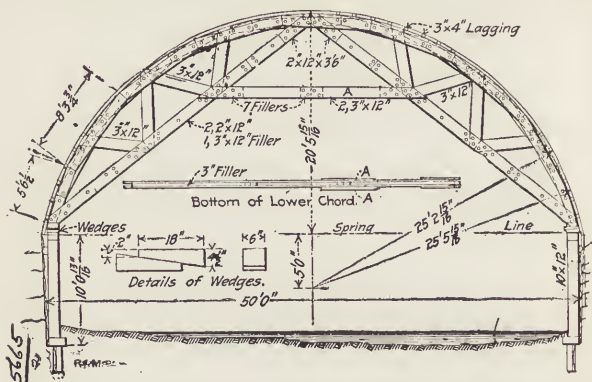

Fig. 113.—Center for 50-Ft. Arch, B. & O. R. R.

2x8-in. planks. The five frames of the center were supported on the caps by wedges. The ribs of the center on which the $2\frac{1}{2}$ x8-in. lagging was placed, were pairs of 2x12-

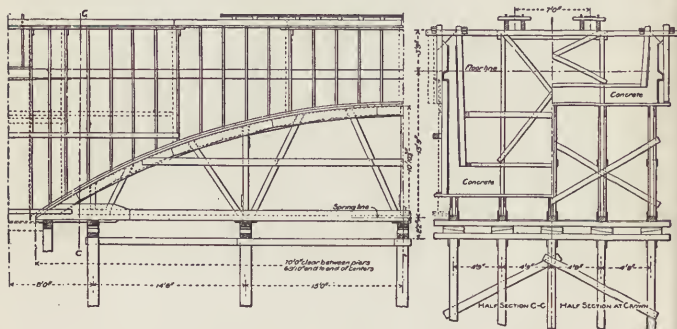

Fig. 114.—Centering and Molds, Pollasky Bridge.

in. plank with 4x10-in. fillers between them, the whole nailed together by 7-in. spikes. The struts consisted of a pair

of 2x6-in. planks with a 4x6-in. piece between them, the latter projecting up into the space between the outside planks of the rib. At the bottom each strut is butted on a 6x8-in. stringer. On either side of the latter was a $1\frac{1}{2}$ x12-in. plank, and $\frac{1}{2}$ -in. bolts passed through the plank and the feet of the struts. In laying out the centers provision was made for a 1-in. camber by using a radius of 61 ft. 11 in. instead of 62 ft. $3\frac{3}{4}$ ins. This gives a rise of 10 ft. $11\frac{3}{4}$ ins. in place of 10 ft. $10\frac{3}{4}$ ins. designed for the arch.

Concreting the Arch.—Wherever possible, it is best to make the concreting of the arch continuous, so that there will be no possibility of a future separation on a plane bounding two days' work. Where it is impracticable to concrete in one continuous operation, the arch ring is divided into sections, either longitudinal or transverse, each section representing a day's work. Both methods have given equally satisfactory results. In either case, great care must be taken at the joining of the new concrete, in order that it may be as nearly monolithic as possible. The joint is made rough, to assist in securing a firmer bond. When the sections are longitudinal, they are so chosen that none of the reinforcing is exposed at any joint between two days' work. When the sections are transverse, the concreting commences either at the crown or the springing, care being taken that no joint is made at the crown, and also that the concreting proceeds symmetrically on both sides of the crown. The sections are not bounded by vertical planes, as in the case of longitudinal sections, but by radial planes, so that all pressure brought upon the planes of juncture will be normal to them. Great care must be taken that the concrete entirely surrounds the reinforcement, and that the reinforcing material is not displaced in the slightest degree in concreting. The spacing and location of reinforcing material are designed very accurately to meet the stresses in the bridge, and unless great care is taken in placing the reinforcement and in concreting, the reinforcement will not fulfill the mission for which it is designed.

Removal of Arch-Centering.—As a rule, arch-centering should be left in place as long as possible. Since concrete shrinks in setting and since wood shrinks in drying, there is a tendency of the concrete to separate from the centering unless the latter be kept wet. This wetting of the forms also supplies the water needed by concrete in setting. There is no definite rule as to the length of time the centering remains in place. In cases where the arch is to be given a form of tooled finish, so that the forms must be removed while the concrete is still green, or in cases where the structure is in several spans and the centering is needed for the others, it is removed earlier. When forms are removed early, great care must be taken that they are lowered gradually. While concrete begins to be self-supporting as soon as it begins to set, it does not reach its maximum strength for some time after setting, so that the removal of forms should be especially provided for. The devices usually employed are wedges or sand boxes. Wedges can be driven out gradually, so that the strain comes upon the arch very slowly. Sand boxes are satisfactory if the necessary precautions are taken to keep the sand from packing or caking, due to the presence of dirt or cement. Care should be taken that the sand is very clean, and that the boxes are sealed up, to prevent the entrance of foreign matter.

Grand River Bridge, Grand Rapids, Mich.—As a typical example of bridge construction, the following description of Grand River bridge will show the general construction, centering and details:

There are five arch spans, one 87 ft., two 83 ft., and two 79 ft. One of the 79-ft. spans is shown in Fig. 115. The arch rings of the 79-ft. spans are 18 ins. thick at crown and 3 ft. at the springing, and are reinforced by two courses of $1\frac{1}{4}$ -in. Thacher bars placed 3 ins. from the extradosal and the intradosal faces.

Each pair of rods is connected every 4 ft. by means of a $\frac{5}{8}$ -in. rod with a hook at each end. The rods have 3-in. washers and nuts to anchor them in the abutments, and are

made continuous from end to end of span by means of turn buckles.

The arch ring was built in transverse sections, each section being built in one continuous operation in a day, first the crown section, then the two skewback sections, and finally the intermediate sections, the entire ring being completed in five days.

Expansion joints in the spandrel walls were formed by laying the concrete against a vertical form and then butting the concrete of the following section against this smooth surface with a sheet of tar paper inserted between. Fig. 116

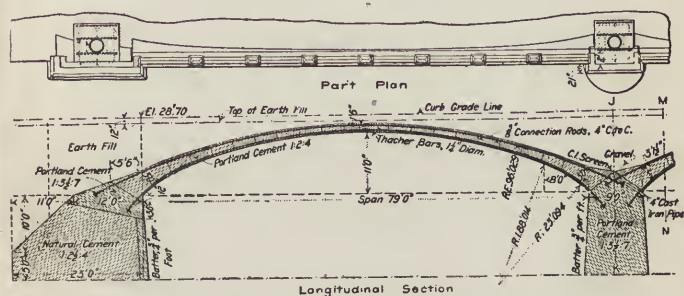

Fig. 115.—Details of 79-Ft. Span, Grand River Bridge.

is instructive in illustrating details of railing and forms for making them. The following loads were assumed:

	Lbs. per cu. ft.
Dead Load:	
Concrete	150
Earth filling	120
Pavement, 12 ins. deep.....	150
	Lbs. per sq. ft.
Live Load:	
Center 20-ft. roadway.....	250
Remainder of roadway.....	150
Sidewalks	100

It should be noticed that these requirements are considerably above the actual loads that will usually come on a bridge. A concentrated load was assumed on the roadway,

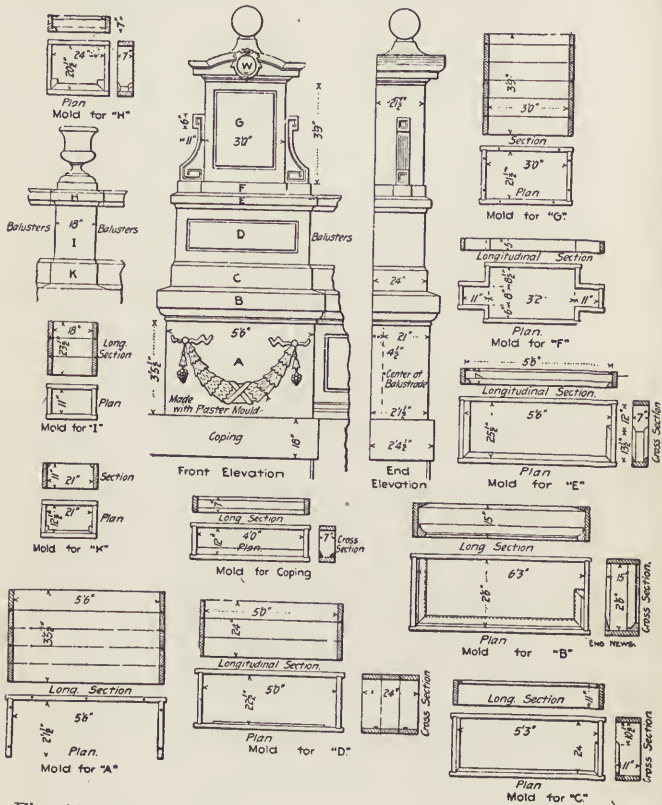

Fig. 116.—Details of Railing and Forms, Grand River Bridge.

consisting of a 15-ton steam roller having axles 11-ft. centers with 6 tons on the forward wheel 4 ft. wide and 4½ tons on each of the two rear wheels 20 ins. wide and 5 ft.

apart on centers. The ratio $\frac{E_s}{E_c}$ was taken as 20, maximum compression in concrete 500 lbs. per sq. in. not including temperature stresses, and 750 lbs. per sq. in. including temperature stresses.

Tension and shear in concrete were assumed not to exceed 75 lbs. per sq. in. and reinforcement stress 18,000 lbs. per sq. in. It was also required that the percentage of steel reinforcement in the crown should be at least equal to 2. Centering for one of the 83-ft. spans is shown in Fig. 117.

The Santa Monica Viaduct.—In 1902 a viaduct of two 67-ft. spans 100 ft. wide was built at Santa Monica, Cal. by Mr. Carl Leonardt, contractor, Los Angeles, Cal., according to plans and specifications prepared by the author. Owing to the 40-ton trolley cars, the arches, 22 ft. in width, were made 12½-in. crown and 16-in. springing, while the balance of the viaduct has a thickness of only 6 inches at the crown and 10 inches at the abutments. The reinforcement consists of two

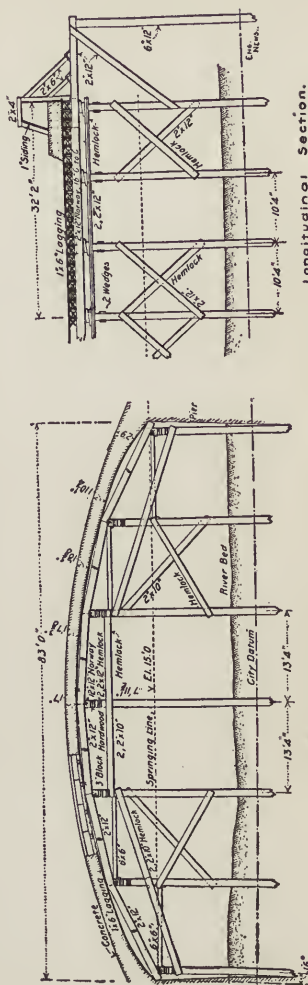

Longitudinal Section.
Elevation.
Fig. 117.—Centering for 83-Ft. Span, Grand River Bridge.

nets of carrying rods spaced 6 inches on centers for the general viaduct and 3 inches on centers under the trolley tracks. The distributing rods are all 6 ins. on centers and at every second crossing are carefully wired to the carrying rods. The carrying rods in the lower net are $\frac{5}{8}$ in. in diameter for one-third of the arch up from the

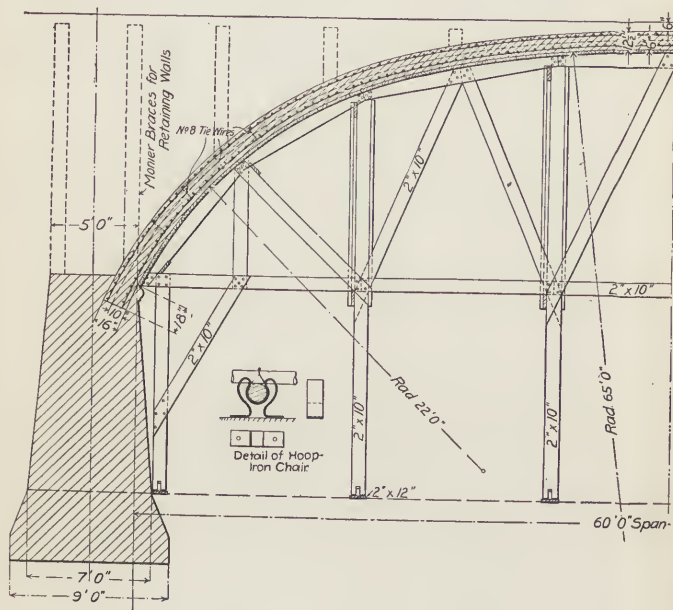

Fig. 118.—Centering and Reinforcement for Santa Monica Viaduct.

abutments, the balance of the rods being $\frac{1}{2}$ in. in diameter. The top net consists entirely of $\frac{1}{2}$ -in. rods. The nets were connected by means of No. 8 wires tying them together and keeping them apart. The intrado net was clasped in hoop iron chairs, tacked on to the form every 30 to 36 ins. square,

and pulled off with a pair of pinchers as the concreting proceeded.

Owing to the fact that the Southern Pacific R. R. Co.'s tracks run under the north span on a curve, the clearance caused the necessity of a slight distortion of the parabola, and was made from one radius 65 ft. and two radii 27 ft. 9 ins. The total rise is 13 ft. 7 ins. As an extra precaution, 3 brackets or counterforts were placed under the trolley line part of the arch, extending from skewbacks over one-third of the arch towards the crown.

For arches of this character it is of the greatest importance that the centering is carefully designed, placed and adjusted by means of wedges so as to maintain the proper curvature during the placing of reinforcement and concrete, and that any shrinkage or swelling of the lumber is compensated for. The forms were built of 2x10-in. planks, spiked together and braced by means of 2x10-in. planks bolted to posts and joists. The posts were slotted at the lower end and rested on 2x12-in. planks firmly bedded in the ground, being made adjustable by means of double maple wedges. The lagging consisted of 1x6-in. boards nailed on top of the rafters transversely across the viaduct, and on top of the lagging was nailed 1x6 dressed flooring bent exactly to the curve of the arch. After both arches were completely scaffolded and centered, the steel rods were laid from the abutment towards the center, the lower netting being kept at the proper distance from the forms by means of hoop iron snap saddles, so arranged that they could be withdrawn after the concreting had proceeded sufficiently to insure that the steel would keep its position. The two nets were kept at the proper distance by No. 8 wire stiffeners at every eighth intersection.

The concreting was started at the abutments and the work made continuous until finished. The mixture was fairly wet, of 1 Portland cement to 4 parts clean, coarse, sharp sand, and the concrete was carefully tamped to a thickness regulated by straight edges with prongs penetrat-

ing to the centering. Three weeks after the concreting was finished the backfilling of earth and sand was put in and the roadway completed.

This is probably the lightest Monier viaduct in the United States. There are, however, a number of reinforced concrete bridges in Germany, Switzerland and France even considerably lighter in construction. Descriptions of these can be found in the files of *Beton & Eisen* and in catalogues of *Wayss & Freitag*, *Hennebique* and others.

CHAPTER IV.

ABUTMENTS AND RETAINING WALLS.

Inasmuch as an abutment is a retaining wall with a surcharge, we will consider the two classes of construction under one head. The author is under obligations to Prof. Milo S. Ketchum, of the University of Colorado, for much of the following, which by permission has been compiled from "The Design of Walls, Bins and Grain Elevators."

THEORIES FOR PRESSURE OF THE FILLING.

The most important theories for finding the pressure of the filling on a retaining wall are as follows:

Rankine's Theory.—Here the filling is assumed to consist of an incompressible, homogeneous, granular mass, without cohesion, the particles being held in position by friction on each other, the mass being of indefinite extent, having a plane top surface and resting on a homogeneous foundation, and being subjected to its own weight. These assumptions lead to the ellipse of stress and make the resultant pressure on a vertical wall parallel to the top surface. The pressure on other than vertical walls can be determined by the ellipse of stress.

Weyrauch's Theory.—Here the filling is assumed to be without cohesion and to be held in equilibrium by friction of the particles on each other. It is also assumed that the forces upon any imaginary plane section through the mass of earth have the same direction. These assumptions lead to two formulas, one giving the amount of the thrust and the other giving its direction, the angle that the resultant makes with a normal to the wall. The formulas deduced by Weyrauch may be obtained more simply by means of the ellipse of stress, and are therefore subject to the same limitations.

Coulomb's Theory.—Here a wedge is assumed, having the wall as one side and a plane of rupture as the other side, which exerts a maximum thrust on the wall. The plane of rupture lies between the angle of repose of the filling and the back of the wall. It may coincide with the plane of repose. For a wall without surcharge (horizontal surface back of the wall) and a vertical wall, the plane of rupture bisects the angle between the plane of repose and the back of the wall. This theory does not determine the direction of the thrust, and leads to many other theories having assumed directions for the resultant pressure.

Cain's Theory.—Prof. William Cain assumes that the resultant thrust makes an angle with the normal equal to ϕ' , the angle of friction of the filling on the back of the wall, or equal to ϕ , the angle of repose of the filling, if ϕ' is greater than ϕ .

Other authorities assume that the resultant thrust is normal to the back of the wall. For a smooth vertical wall without surcharge, all of the above formulas lead to the same result for the amount, direction and point of application of the resultant thrust.

Trautwine's Theory.—In Trautwine's Engineers' Pocket-book it is assumed, for a wall nearly vertical, that the plane of rupture in all cases bisects the angle between the plane of repose and the back of the wall. This theory gives correct results for a vertical wall with horizontal surface back of the wall, but is in error for all other cases.

Rankine's Formulas.—For vertical retaining walls without surcharge:

$$P = \frac{1}{2} wh^2 \frac{1 - \sin \phi}{1 + \sin \phi} \dots \dots \dots (42)$$

and

$$q = wy \frac{1 - \sin \phi}{1 + \sin \phi}$$

where

P = resultant earth pressure per foot length of wall.

w = weight of filling per cubic foot.

y = depth of foundation below earth surface.

q = horizontal pressure at a depth equal to y .

h = vertical height of wall in feet.

ϕ = angle of repose of the filling.

For angle of surcharge = δ , Rankine's formula is:

$$P = \frac{1}{2}wh^2 \cos \delta \frac{\cos \delta - \sqrt{\cos^2 \delta - \cos^2 \phi}}{\cos \delta + \sqrt{\cos^2 \delta - \cos^2 \phi}} \dots \dots \dots (43)$$

Cain's Formulas.— If ϕ' = angle of friction of the filling on the back of the wall

θ = angle between back of wall and the horizontal running back into the filling

for $\delta = 0$

$$P = \frac{1}{2}wh^2 \left(\frac{\cos \phi}{n + 1} \right)^2 \frac{1}{\cos \phi'} \dots \dots \dots (44)$$

where

$$n = \sqrt{\frac{\sin (\phi + \phi') \sin \phi}{\cos \phi'}}$$

If $\phi' = 0$, we have

$$P = \frac{1}{2}wh^2 \tan^2 \left(45^\circ - \frac{\phi}{2} \right) \dots \dots \dots (45)$$

For surcharge = δ , the value of P is the same as in Formula (45) except that

$$n = \sqrt{\frac{\sin (\phi + \phi') \sin (\phi - \delta)}{\cos \phi' \cos \delta}}$$

For inclined wall with horizontal surfaces:

$$P = \frac{1}{2}wh^2 \left(\frac{\sin (\theta + \phi)}{(n + 1) \sin \theta} \right)^2 \frac{1}{\sin (\phi' + \theta)} \dots \dots (46)$$

where

$$n = \sqrt{\frac{\sin (\phi + \phi') \sin \phi}{\sin (\phi' + \theta) \sin \theta}}$$

For inclined wall with surcharge = δ , the value of P is the same as in Formula (46) except that

$$n = \sqrt{\frac{\sin (\phi + \phi') \sin (\phi - \delta)}{\sin (\phi' + \theta) \sin (\theta - \delta)}}$$

GENERAL DISCUSSION.

Thrust.—In calculating the thrust on a retaining wall, great care must be used in selecting the proper value for the angle of repose and the conditions of surcharge, as the value of the thrust increases very rapidly as the angle of repose decreases and as the angle of surcharge increases.

Back Filling.—The filling back of the wall should be deposited and tamped in approximately horizontal layers, or in layers sloping back from the wall, and a layer of sand, gravel or other porous material should be deposited between the fill and the wall to drain the fill downwards.

Drainage.—To insure drainage of the filling, drains should be provided back of the footing, and weep-holes located in the body of the wall at close intervals. The filling in front of the wall should also be carefully drained.

Expansion Joints.—In order to prevent the heaving of the foundation by frost, it is usual to provide from $2\frac{1}{2}$ to 5 ft. of filling in front of the wall. While in solid masonry walls it is necessary to locate expansion joints at intervals of from 30 to 50 ft., to prevent cracks, such joints are frequently omitted in retaining walls of reinforced concrete, and reinforcement is placed in the direction of the length of the wall for such purpose.

Temperature Cracks.—Mr. A. L. Johnson gives the following formula for the amount of reinforcement required to prevent temperature cracks.*

$$\text{Area of steel} = \frac{\text{tensile strength of concrete}}{\text{elastic limit of steel}} \times \text{area of concrete.}$$

For mild steel the elastic limit is 33,000 lbs. per sq. in., the tensile strength of concrete is about 200 lbs. per sq. in., and the area of steel is $\frac{1}{165}$ of the area of the wall.

For high steel of an elastic limit of 55,000 lbs. per sq. in., we find the area of steel required to prevent temperature

*Railroad Gazette, March 13, 1903.

Calculation of Resultant Pressure.—To calculate the resultant pressure, P , proceed as follows: Draw AO parallel to the surcharge $A'M''$ and at any convenient point O in AO draw OD at right angles to AO . Draw OM vertical and locate M by striking the arc DM with O as a center, and OD as a radius. Draw OC , making the angle ϕ with OD . At any point e in OD describe an arc tangent to OC and cutting OM at f . Through M draw MG parallel to ef . Bisect the angle DGM and through O draw OR parallel to GR' . Then OR is the principal axis of the ellipse of stress and OM'' the maximum stress that can occur in the filling. To calculate the maximum stress at A , draw OG' at right angles to the back of the wall AA' , and make $OG' = OG$. With G' as center and OG' as radius, describe an arc cutting the principal axis OR at t . Draw $G't$, and with G' as a center and GM as a radius locate M' . Then $M'O$ acting as shown is the intensity of the stress at A . The resultant pressure P is equal to the area of the stress triangle $AA'N \times w$, where w is the weight per cu. ft. of the fill. P acts on AA' at $\frac{1}{3}$ the height of the wall.

The weight of the masonry, W , combined with P gives the resultant E , which must cut the foundation within the middle third. The vertical component of E is F .

Stability Against Overturning.—Through B draw $O'S$ and produce cd to S . Then the factor of safety against overturning is $\frac{Sc}{dc}$. If E passes through B , the wall would be on the point of overturning and $\frac{Sc}{dc}$ would be equal to 1.

Stability Against Sliding.—The angle of friction of the masonry against the footing we will take as,

$$\phi' = 30^\circ$$

Through O' draw gk , cutting the base of the wall at i at 30° to the vertical. Then the factor of safety against sliding will be

$$\frac{kn}{dm}$$

Stability Against Crushing.—The direct pressure per sq. ft. will be

$$p_1 = \frac{F}{BA}$$

where BA is the width of the base.

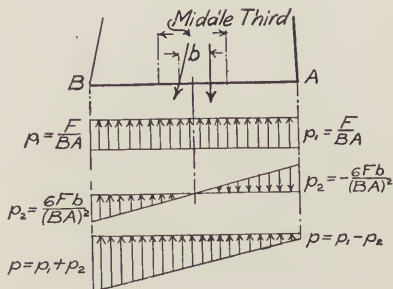

Fig. 120.—Diagram of Moments for Masonry Retaining Wall.

The pressure due to the bending moment will be (see Fig. 120):

$$p_2 = \pm \frac{6Fb}{(BA)^2}$$

The maximum pressure will be

$$p = p_1 + p_2,$$

and the minimum,

$$p = p_1 - p_2.$$

If, in addition to the foregoing assumptions, we assume the wall to be 18 ft. high,

$$A'B' = 2 \text{ ft. 6 ins.}$$

$$AB = 7 \text{ ft. 6 ins.},$$

the batter of the back wall AA' $\frac{3}{4}$ in. per ft., the masonry to weigh 150 lbs. per cu. ft., and the fill, w , 100 lbs. per cu. ft., we find the following result:

$$P = \frac{16 \times 6.1}{2} \times 100 = 4880.$$

$$W = \frac{2.5 + 7.5}{2} \times 18 \times 150 = 13500 \text{ lbs. per lin. ft. of wall.}$$

$$E = 16500$$

$$b = 1.1 \text{ ft.}$$

$$F = 16000$$

$$p_1 = \frac{16000}{7.5} = 2133$$

$$p_2 = \frac{6Fb}{d^2} = \frac{6 \times 16000 \times 1.1}{7.5 \times 7.5} = \pm 1877$$

$$p = 4010 \text{ or } 256.$$

REINFORCED CONCRETE RETAINING WALL OF BEAM TYPE.

Design a reinforced concrete retaining wall of the beam type, to carry a sand filling 16 ft. high, weighing 100 lbs. per cu. ft., and having an angle of repose of 35° , and sloping back at that angle.

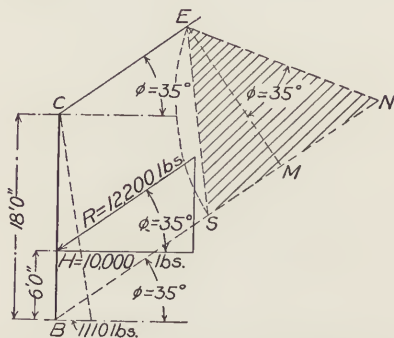

Fig. 121.—Diagram of Forces for Reinforced Concrete Retaining Wall.

The Vertical Beam.—The bottom of the foundation will need to be about 4 ft. deep and we will assume the stem of the wall to be 18 ft. high. In Fig. 121 the pressure is

$$P = \Delta SEN \times w = 12,200 \text{ lbs.}$$

and is parallel to the top surface. The horizontal component of P is

$$H = 10,000 \text{ lbs.}$$

The bending moment about B is

$M' = 10,000 \times 6 = 60,000$ ft. lbs., for 1 ft. wide, or inch lbs. for 1 in. wide.

Instead of using Table XLVI, we will make $n = 12$, $p = 0.006$ and $f = 16,000$. According to Table XXXIX, we have,

$$1 - \frac{k}{3} = 0.896 \text{ and}$$

$$M_s = pf \left(1 - \frac{k}{3}\right) bd^2$$

$$d = \sqrt{\frac{60,000}{0.006 \times 16,000 \times 0.896}} = 26.6 \text{ ins.}$$

and $h = 30$ ins. The top is 12 ins. thick.

The steel reinforcement required per foot width of the wall is

$$A_s = 26.6 \times 12 \times 0.006 = 1.915 \text{ sq. ins.}$$

Three 1-in. rods $= 3 \times 0.7854 = 2.356$ sq. ins.

or 1-in. rods, 4 ins. on centers, with 4 in. by 6-in. mesh No. 7 and No. 11 fabric on both sides for temperature stresses.

Foundation.—We will assume that the footing is 10 ft. long, as shown in Fig. 122. Then the pressure on the plane $A'F$ is

$$P' = 19,900 \text{ lbs.}$$

The weight of the earth prism $AA'BF$ is 7,425 lbs. and

$$P = 25,000 \text{ lbs.}$$

Combining P and the weight of the wall, which, including reinforcement, we will call 7,725 lbs., we have

$$E = 31,000 \text{ lbs.,}$$

which cuts the base 2 ft. to the left of the center, outside the middle third.

Now

$$F = 24,000 \text{ lbs., and}$$

$$p_1 = 2,400 \text{ lbs. per sq. ft.,}$$

$$p_2 = \frac{6Fb}{d^2} = \pm 2,880 \text{ lbs., hence}$$

$$p = 5,280 \text{ or } -480 \text{ lbs. per sq. ft.}$$

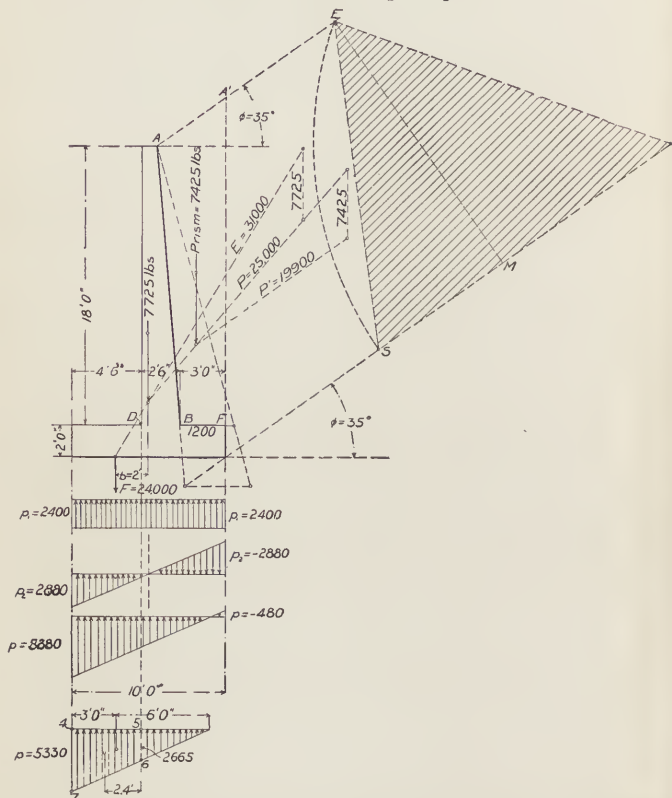

Fig. 122.—Diagram of Forces for Reinforced Concrete Retaining Wall.

Since the foundation cannot take tension, we will have to let all the load be taken by compression as follows:

$$p' = \frac{2F}{3a} = \frac{2 \times 24000}{3 \times 3} = 5,330 \text{ lbs. per sq. ft.}$$

This pressure is safe for good gravel or clay. While the resultant cuts outside the middle third, the base is sufficiently long for the conditions named.

To calculate the bending moment to the left of *D*, take the lower stress diagram, 4-5-6-7, Fig. 122, and multiply it by the distance of its center of gravity to the left of *D*.

$$\text{Then } M' = \left(\frac{5,330 + 2,665}{2} \right) 4\frac{1}{2} \times 2.4 = 43,200 \text{ ft. lbs.}$$

Table XLVI gives for a moment of 49,465,

$$h = 24.$$

and for 40,880,

$$h = 22.$$

We will put in $0.17 \times 4\frac{1}{2} = 0.765$ sq. ins., or 1-in. rods $4\frac{1}{2}$ ins. on centers, the full length of the foundation. Rods will be placed 2 ins. from top of the inner surface, as shown, and these rods we will make 1 in. in diameter, and 8 ins. on centers. See Fig. 123.

REINFORCED CONCRETE RETAINING WALL, WITH COUNTER- FORTS.

Design a reinforced concrete retaining wall with counterforts to carry a sand filling $17\frac{1}{2}$ ft. above ground, which weighs 100 lbs. per cu. ft., has an angle of repose of $37^\circ 30'$, and carries a railroad track which is equivalent to a surcharge of 6 ft. Counterforts to be spaced 10 ft. on centers, as shown in Fig. 125.

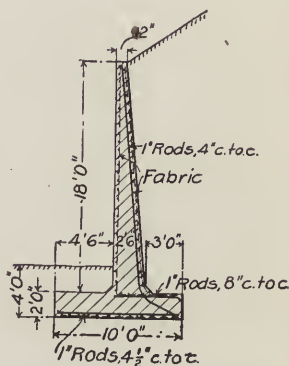

Fig. 123.—Section of Reinforced Concrete Retaining Wall.

Resultant E cuts the base at a distance 1.6 ft. from the center, and the vertical component of E is

$$F = 21,500 \text{ lbs.}$$

Vertical Wall.—In designing the center slab the span will be taken as 10 ft. (Where the wall has no cracks the

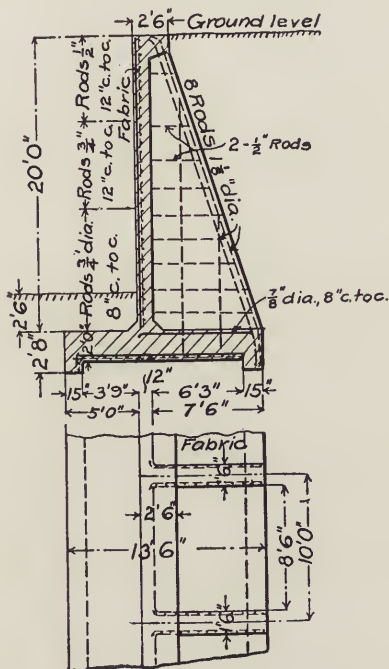

Fig. 125.—Plan and Section of Wall, Showing Reinforcement.

actual span is less than the clear span of 8 ft. 6 ins.) Taking the bottom strip, 1 ft. wide, and 10 ft. long, we design a simple beam that will carry a load of 623 lbs. per linear ft.

$$M = \frac{623 \times 10^3}{8} = 7,788 \text{ ft. lbs. (or inch lbs. per inch).}$$

$$M_s = pf \left(1 - \frac{k}{3}\right) bd^2$$

Again making $n = 12$, $p = 0.006$, and $f = 16,000$, we get

$$d = \sqrt{\frac{7,788}{0.006 \times 16,000 \times 0.896}} = 9.5 \text{ ins. and } h = 12 \text{ ins.}$$

The steel area per foot is:

$$0.006 \times 9.5 \times 12 = 0.684 \text{ sq. ins.,}$$

or $\frac{3}{4}$ -in. rods, 8 ins. on centers, grading the distance between rods according to the decreasing pressure toward the top. See Fig. 125. The temperature stresses will be taken care of by means of 4×6 ins. No. 7 and No. 11 fabric, to which the rods are fastened by wire—usually doubled No. 18 annealed wire.

Counterforts.—The bending moment on a counterfort at OG in Fig. 124 will be,

$$M' = 7,720 \times 8 \times 10 = 617,600 \text{ ft. lbs., or } 7,411,200 \text{ in. lbs.}$$

If the counterfort is 18 ins. wide we have:

$$M = \frac{7,411,200}{18} = 411,733 \text{ in. lbs., for 1 in. width.}$$

By Formula (11)

$$M_s = pf \left(1 - \frac{k}{3}\right) bd^2$$

and for $f = 16,000$, $p = 0.006$, and $n = 15$, we find

$$\left(1 - \frac{k}{3}\right) = 0.885.$$

$$\text{Hence } d = \sqrt{\frac{411,733}{0.006 \times 16,000 \times 0.885}} = 70 \text{ ins.} = 5 \text{ ft. } 10 \text{ ins.}$$

Steel area for 18 ins. width is

$$0.006 \times 70 \times 18 = 7.56 \text{ sq. ins.,}$$

or 8 rods, $1\frac{1}{8}$ ins. diameter. Rods $\frac{1}{2}$ in. in diameter will be placed as shown in addition to fabric to take vertical and horizontal shear.

Foundation.—In Fig. 124 the direct pressure p_1 is 1,600 lbs. per sq. ft., while the pressure due to the moment is

$$p_2 = \frac{6 Fb}{d^2} = \pm 1,120 \text{ lbs. per sq. ft.}$$

Then

$$p = 2,720 \text{ or } 480 \text{ lbs. per sq. ft.}$$

which is entirely safe for ordinary conditions. The maximum moment at K in the outer toe is found in Fig. 124 by taking the moment area to the left of K , and is

$$M' = \left(\frac{2,720 + 2,000}{2} \right) 5 \times 2.6 = 30,680 \text{ ft. lbs.}$$

By Table XLVI this corresponds to a slab between 19 and 20 ins. However, we have assumed 24 ins. We will use steel area of 0.15 sq. in. per inch, or $\frac{7}{8}$ -in. rods 4 ins. on centers and place $\frac{7}{8}$ -in. rods 8 ins. on centers at top of slab as shown. At the bottom we will, in addition to 4×6 -in. fabric of Nos. 7 and 11 gage, place $\frac{5}{8}$ -in. distributing rods longitudinally 8 ins. on centers.

Conclusion.—It will be noticed that in the foregoing example a rib is placed longitudinally underneath the heel and the toe of the base. This is largely for the purpose of confining the soil between the two ribs and to aid in preventing sliding.

For long retaining walls the face slab should be decreased in thickness from bottom towards the top, as the saving in concrete will be greater than the additional cost of the tapered forms.

RETAINING WALL FORMS.

Construction.—Fig. 126 shows type of panel form used for the concrete retaining walls on the Port Morris Branch of the N. Y. C. & H. R. R. R. It is described by Mr. Jonett, the resident engineer, as follows:

For walls up to 10 ft. in height the design as shown in Fig. 126 is used. If built for higher walls, there should be four cleats and uprights to a 10-ft. panel, in place of 3, as shown in the cut. The plank for these panels is straight grained, faced on all sides, free from defects and made of

cypress or spruce, or such material as will not warp much. The face of the panels is an absolute plane, and the edges perfectly true, so there can be no joint between adjacent panels. Likewise, the ends are cut square, so the panels will fit tightly end to end.

Care of Forms.—After the panels are made they are rubbed with a black oil to fill the pores and the first time they are used are brushed over with soft soap. When taken down they are thoroughly scraped with wooden scrapers and hot water, given a coat of black oil and piled so they lie absolutely flat, and if possible, under cover, to prevent warping. Great care is taken in handling the panels not

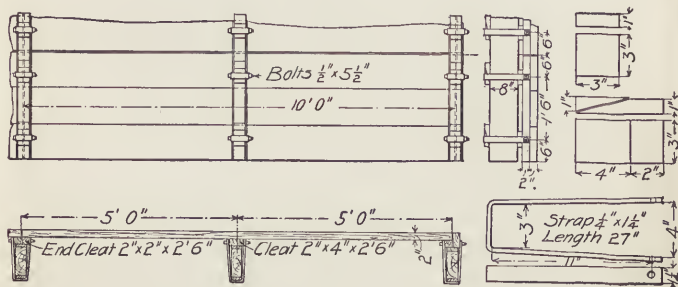

Fig. 126.—Forms for Wall, Port Morris, N. Y.

to batter the edges. If they are battered, or if planks are warped so as to open up a joint, it is filled or made straight by means of a strip of wood, oakum or putty.

Setting the Forms.—In setting the forms, great care is taken to set the apparatus on a firm base and thoroughly brace it. The first panels are set in a line end to end with tight joints and absolutely leveled. After the lower line is set correctly, the others will come all right, and as soon as the lower line is in place the concreting may begin. The concrete is placed in layers not to exceed 12 ins. in thickness and the face is thoroughly spaded so as to bring the

fine mortar to the face, or a cement mortar of same mixture as mortar in the concrete may be slushed along the face.

The next panel above may be placed as the concrete is brought up without interfering with the placing of the concrete so that carpenters and concrete men may be working at the same time and place.

Removing the Forms.—After the concrete against the lower line of panels is placed the panels can be removed after 18 hours in the summer and 24 to 30 hours in the winter, and floating of the surface can be started, even though concreting may be going on at the top of the wall. After the proper lapse of time on the other lines of panels they may be removed and the wall floated until the top is reached. To remove the panels, the wedges are drawn, the blocks are removed, and the panels are drawn out endwise.

When forms are removed the walls should be green and easily worked. The floating is done with wooden floats or cement bricks. Cement plaster should be positively forbidden, though fresh water may be splashed over the wall to assist the rubbing off of all board marks or ridges and to bring to a uniform smooth surface.

Expansion Joints.—Expansion joints are formed from 30 to 50 ft. apart by placing tar paper through the entire area of wall section. The number of thicknesses depends upon the season of year, only 1 in the summer and 5 or 6 in the winter.

The first cost of these forms is high, but for a considerable stretch of work they can be used over and over again if made of good material and taken care of properly.

Wall Form Tie.—Fig. 127 is a simple form for a heavy wall, such as is employed by the author. The tie is formed of wire, which is tightened by twisting, as shown.

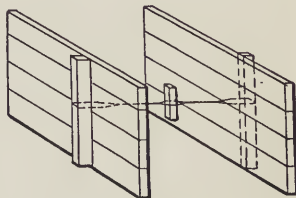

Fig. 127.—Wall Form Tie.

EXAMPLES OF CONSTRUCTION.

Retaining Wall, Paris, France.—Fig. 128 shows a modification of the usual type of wall with counterforts. This wall is of Hennebique construction and was built to support the sides of a depressed street near the gardens of the Trocadero, at the Paris Exposition of 1900. The wall was built

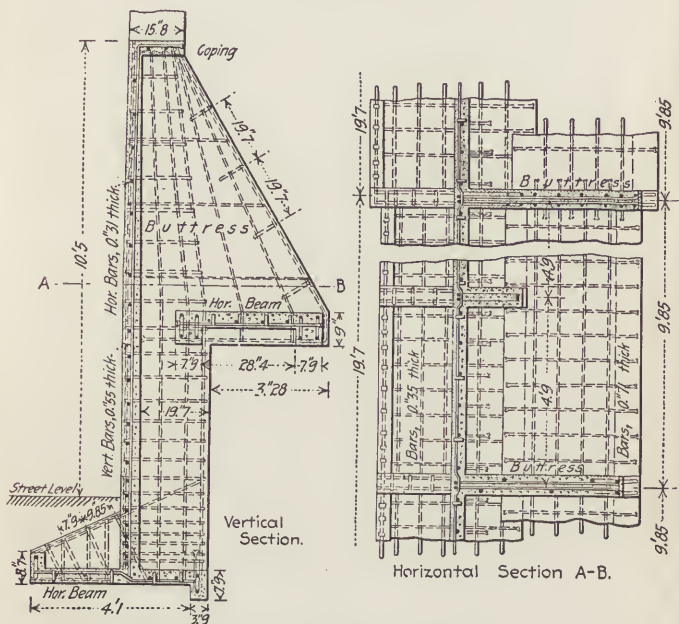

Fig. 128.—Retaining Wall for Sunken Street, Paris, France.

in sections about 20 ft. in length, each section being made up of a facing strengthened at its back by three buttresses. Two horizontal beams connected the facing and the buttresses. The base slab was strengthened at the toe of the wall by buttresses underneath the street level, as shown.

By this arrangement of horizontal beams the retaining wall is assisted in sustaining the earth pressure by the weight of this earth upon the horizontal beams—and does not, as in ordinary retaining walls, depend upon its weight alone.

The employment of the two separate beams at different levels, instead of the one at the same total width, results in largely decreasing the thrust of the earth upon the vertical face—and reduces the excavation required. The two rear beams are only used in nine panels, as the retaining wall is protecting a sloped street, and the height of the wall is reduced at one end so as to need but one base. The width of the front horizontal beam was fixed by assuming a top load of 2,048 lbs. per sq. ft. upon soil of this nature. The width of the back of the wall was figured with an average factor of safety of 2, in calculating the moment of stability of the wall.

The reinforcement of the vertical face consists of two series of vertical bars combined with one series of horizontal bars, the distances between which increase towards the top of the wall. These bars are bent over at right angles at the top to give support for a coping of the same construction as the facing. The illustration gives the sizes of the different bars or rods.

Retaining Wall, Great Northern Ry., Wash.—A good example of a high reinforced concrete retaining wall is here reprinted.* The wall, Fig. 129, is of the counterfort type and is used in the terminal yard of the Great Northern Railway at Seattle, Wash. The wall supports a street and varies in height from 2 to 37.8 ft. and is approximately 2,000 ft. in length. Mr. C. F. Graff of the engineering staff of the Great Northern Railway states that a comparison of cost between a plain concrete wall of gravity section and a wall of counterfort type gave a noticeable saving for the latter, as shown in Table LXIV. The heights vary from 10 to

*Reid's Concrete and Reinforced Concrete Construction.

40 ft., the section of wall is assumed 1 ft. long, figuring the amount of steel used at $4\frac{1}{2}$ cts. per lb., evaluated in terms of concrete at \$6.00 per cu. yd. in place.

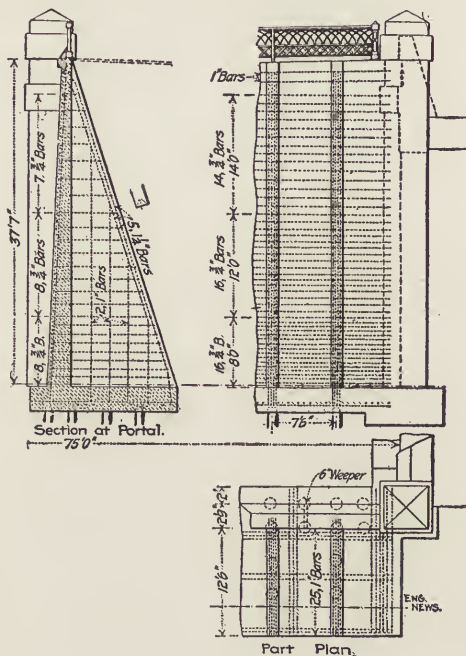

Fig. 129.—Retaining Wall, Great Northern Ry., Seattle, Wash.

TABLE LXIV.—COMPARATIVE QUANTITIES OF CONCRETE IN PLAIN AND REINFORCED CONCRETE RETAINING WALLS.

Height Wall in feet.	Cu. Ft. Concrete Plain Wall.	Cu. Ft. Concrete Reinforced Wall.	Saving Per cent.
10	44	34.9	20.4
20	110	69.9	36.4
30	226	127.8	43.4
40	396.4		45.0

It was assumed in this estimate that the extra cost for forms and a higher grade of concrete for a reinforced wall was counterbalanced by the saving in piling necessary for the plain concrete wall. Fig. 129 shows elevation, section and plan of wall at its highest point; where it joins the portal at the highest point it is 37 ft. 7 ins. high. The general dimensions and reinforcement employed are shown on the drawing. In computing sections of face and base of wall they were considered as composed of a series of independent beams lying side by side, giving an additional factor of safety, as there is really a supported slab action. Piles were driven, as shown, to compact the earth, to support the toe of the wall and to prevent the structure from sliding forward. Scaffolding was put up to facilitate the erection of the skeleton steel work. Near the top of this scaffolding the two top 1-in. horizontal face bars were securely fastened in exact line and elevation and the long diagonal $1\frac{1}{4}$ -in. bars running down the back of each rib were hooked on these and swung into proper position at the bottom. Some of these bars were 42 ft. in length, and were kept from sagging by wooden crosspieces nailed to falsework. The $\frac{1}{2}$ -in. vertical face bars were then hung from the top and held in place in a similar manner. Next the vertical bars in each rib were placed, being stuck in the ground at the bottom and held at the top by wire tied to the scaffolding.

In construction, 3 ins. of concrete was first placed above the top of the piles, the horizontal longitudinal rods were put in place, and then the concreting carried up throughout the whole section. As the work was brought up, the horizontal bars in the face and ribs were put in place, care being taken in all cases to bed them in fresh concrete. The laps, where the rods were spliced, were made at the ribs, a 2-ft. lap being used for the base and $1\frac{1}{2}$ -ft. lap for the face wall. Corrugated bars were used throughout. A 1-2-4 mixture of Portland cement, sand and trap rock was used for the concrete. A fairly wet mixture was employed, being deposited in 6-in. layers and thoroughly tamped.

SPECIFICATIONS FOR REINFORCED CONCRETE RETAINING WALL.

The following specifications for reinforced concrete retaining wall have been used by the author and show the method of construction:

General.—The concrete used in reinforced concrete must be of the classes called for on the plan, or as directed by the engineer, and must be in accordance with the general specifications for concrete. It must be mixed, generally, to the consistency known as "wet concrete," or such that a man walking on same will sink ankle deep. The decision of the engineer as to the proper consistency of any batch of concrete must be binding upon the contractor. Special rammers must be used as directed by the engineer, to properly pack the concrete between and around the steel bars.

Workmanship.—Particular care must be exercised in the execution of reinforced concrete work in order to procure a dense and uniform mixture, thoroughly compacted around the reinforcing material.

Reinforcement.—The contractor must furnish and embed in the concrete round rods or bars of dimensions shown on plans, wherever same are called for by the plans, or when directed to do so by the engineer.

The bars must be of medium open-hearth steel, in strict conformity to Manufacturers' Standard Specifications for 1903, and must be in accordance with the specifications under heading "Iron and Steel."

The section of the rod or bar must be the same as that called for on the plan. The rods or bars must be cleaned of all dirt, grease and other adhering substances, and must be free from rust and mill scale. In placing them the directions of the engineer must be strictly followed in regard to spacing, position in the cross-section of the concrete, length, laps, wiring, bending, etc.

In placing the reinforcement the following *modus operandi* should be observed:

After the piles have been driven, the ground properly leveled off and the forms for the base plate have been set in the ground, the 4x12-in. mesh American wire netting No. 9 and No. 11 mesh should be unrolled longitudinally with the abutments from one side of the same to the other and connected properly with clips, stretched and attached to the side forms. In a similar manner the netting for the two wing walls should run parallel with the outside face, lapping the other netting 12 ins. and also fastened to same with clips.

These clips are furnished free with the netting. On top of this netting should be located the rods as shown in the plan and tied to same at every fourth intersection with No. 18 annealed wire laid double, using a No. 8 pair of nippers for the purpose. While cutting the above mentioned netting in lengths, a double set is cut and laid ready, so as to be prepared to place same as soon as the concrete has reached near the top of the slab. Stakes should be driven back of the base form with cross arms to support the outmost rods of the counterforts which are to be embedded in the concrete. The concrete is now placed as rapidly as possible and fairly dry and tamped, and in placing, by means of separate hooks the lower wire netting is pulled and shook away from the soil, leaving a cover of about $1\frac{1}{2}$ ins. to 2 ins. between the soil and the reinforcement.

While this is going on, the reinforcing gang is preparing for the second layer of netting and the top rods, and must have them all laid out in the rotation in which they are to be placed. The reason that the concrete in the base plate is to be fairly dry is for the purpose of being able to place the wire netting and rods, gradually following up the complete concreting. The top concreting can commence at one end of the wing wall and one end of the abutment, while they are still concreting the lower part of the opposite end. Immediately after the top layer of netting and rods is laid, the oblique tension rods in the counterforts are stuck in the concrete as far down as they can go and stayed at the top by means of stay laths fastened to stakes driven in the ground on both sides of the base plate.

This is done during the top finishing. Meanwhile the lumber and braces for the front slab and wing walls have been made ready for rapid erection and the 4x6-in. No. 9 and No. 11 American wire is placed horizontally in one length around the circumference of the wing walls and abutments, suspended at the top from hooks or nails fastened to the studs of the front form, not to the forms themselves. The second layer of netting is suspended to the first one by means of the clips and so on until the bottom is reached. Then the rods are fastened to the wire netting by means of annealed wire at every fourth intersection until the bottom is reached. When this is done the rods of the counterforts which have been embedded in mortar are bent forward until they are in proper position and the 6x6-in. mesh No. 9 and No. 11 American wire is wired to each set of rods in the counterfort and also wired to the front netting and one side of the counterfort forming as erected, the other side

being made in one piece with the part of the forms for the face slab running between the counterforts, in sections about 2 ft. high. Then concreting can commence and section by section carefully spaded, and a somewhat more wet consistency may be used than in the bottom slab.

Any other method of work accomplishing the same purpose—namely: the proper location of all netting and all rods—may be used at the contractor's discretion, with the approval of the engineer.

As all rods of every description are to be hooked at least 1 in., it may be added that the corners of these hooks need not be square but may be made to a radius of 1 in. All splices of rods are done by hooking both ends and lapping them 50 diameters with three ligatures of No. 18 annealed wire, and all splices must break joints.

Rods or bars must be braced so as not to be displaced by springing or by the ramming of the concrete. No reinforcement will be allowed within 1 in. of any exposed surfaces. No concrete except the foundation course can be placed until the entire reinforcement has been placed, wired and approved by the engineer.

Vertical and horizontal rods or bars shall be of the lengths shown on the plans. In beams, face slabs and floor slabs, the rods shall be continuous over two supports.

Loading and Risks.—No vertical or heavy loads shall be allowed on any reinforced concrete structure within 30 days after the completion thereof, nor until such time as the engineer may designate. The contractor will be held responsible for any failure due to faulty workmanship or material, premature loading or premature removal of forms.

Measurement and Payment.—The steel rods or wire netting or bars shall be paid for at the unit price per pound or per square foot named in the contract. Payment will be made upon the estimated weight of rods and bars computed upon the basis of 490 lbs. per cu. ft., for the lengths and cross sections indicated on the plans or placed by order of the engineer. If bars of larger cross section than called for are used the excess shall not be paid for. No allowances will be made for waste or laps, except where laps are shown on plans, or made by direction of the engineer. The unit price per pound must include the furnishing, bending, placing and wiring of the rods or bars, and all labor, tools, wire, and other material necessary to complete the work.

Reinforced concrete, exclusive of the reinforcing material shall be paid for at the unit prices named in the contract, and no deduction will be made for the volume of concrete displaced by the steel.

CHAPTER V.

CULVERTS, CONDUITS, SEWERS, PIPES, AND DAMS.

ARCH CULVERTS.

For arch culverts the design is made the same as for arches in bridge construction, the elastic theory forming the basis. If extradosal and intradosal reinforcement is employed, it is not necessary that the pressure line comes within the middle third, and therefore quite light constructions may be made with safety. The thrust from the arch is transferred to the base by means of buttresses, which thus with the comparatively thin face walls and the base replace the heavy abutments in masonry construction. Culverts are built with or without inverts according to the stability of the soil and the local conditions.

BOX CULVERTS.

Box culverts are calculated like floor slabs. The following method of finding the pressure on a box culvert is based upon the method outlined by Mr. W. W. Colpitts, C. E., in "Railway Age," Aug., 1907:

Assumptions.—The live load is taken at 10,000 lbs. per linear foot of track uniformly distributed by the ties over 8 ft. width of roadway. The further distribution of the load downwards is based upon the unfavorable assumption that the zero load line follows a slope of $\frac{1}{2}$ to 1.

Design of Covers for Box Culverts.—Let $DL =$ dead load per sq. ft. on a plane h ft. from the base of rail.

g = weight of fill per cu. ft.

Then $DL = gh$.

LL = live load in lbs. per sq. ft.

$Q = DL + LL$.

For $g = 100$ lbs., we have:

$DL = 100 h$, or for a factor of safety of 2 for the dead load,

$DL = 200 h$.

$LL = \frac{20,000}{h+16}$ for a 10,000 lbs. train load.

Taking an impact of 50 per cent and a factor of safety of 4 for the live load, we have:

$$LL = \frac{120,000}{h+16}$$

and
$$Q = DL + LL = 200 \left(\frac{600}{h+16} + h \right)$$

Then we have
$$M = \frac{wl^2}{8} 12 = 300 l^2 \left(\frac{600}{h+16} + h \right) \dots \dots \dots (47)$$

where l is the span of the culvert in feet.

For $n = 15$, and $p = 0.0072$, we find by interpolation in Table XXXIX,

$$k = 0.369.$$

Therefore $A_s = 0.0072 \times 12 \times d = 0.086 d \dots \dots \dots (48)$

Assuming $C = 2,300$ lbs. per sq. in. (ultimate), and substituting in Formula (10),

$$M = \frac{1}{2} Ck (1 - k/3) bd^2$$

we get

$$M = 4460 d^2$$

or

$$d = \sqrt{\frac{M}{4460}} \dots \dots \dots (49)$$

where M represents the ultimate moment.

Diagram for the Design of Covers for Box Culverts.—In Fig. 130, plotted from Formulas (47), (48) and (49), Curve A gives the theoretical thickness of cover for various spans under banks between 30 and 40 ft. high. Curve a gives the area of

steel reinforcement per linear foot of cover for banks between 30 and 40 ft. high. Curves B and b and Curves C and c corre-

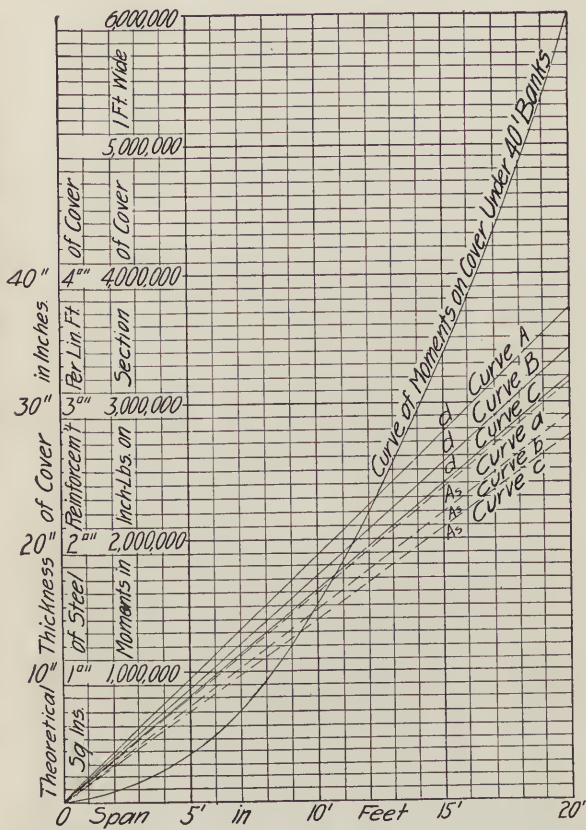

Fig. 130.—Diagram for the Design of Covers for Box Culverts.

spond to the above under banks respectively 22 to 30 ft. high and 0 to 22 ft. high.

Each curve is calculated for the maximum height of bank shown. To the theoretical thickness of the cover, d , should be added from $1\frac{1}{2}$ to 3 ins., sufficient to embed the bars.

Design of Sides of Box Culverts.—For the sides of box culverts the resultant horizontal pressure on the walls is approximately

$$P' = \frac{gh^2}{4}$$

and the horizontal pressure at base of wall in lbs. per sq. ft. is

$$P'' = \frac{gh}{2}$$

$$P = P' + P'' = \frac{60,000}{h + 16} + 100h \dots \dots \dots (50)$$

in lbs. per sq. ft. applied over the entire surface of the side wall of the culvert.

Diagram for the Design of Sides of Box Culverts.—Fig. 131 is plotted from Formulas (47), (48) and (50). Curve D is

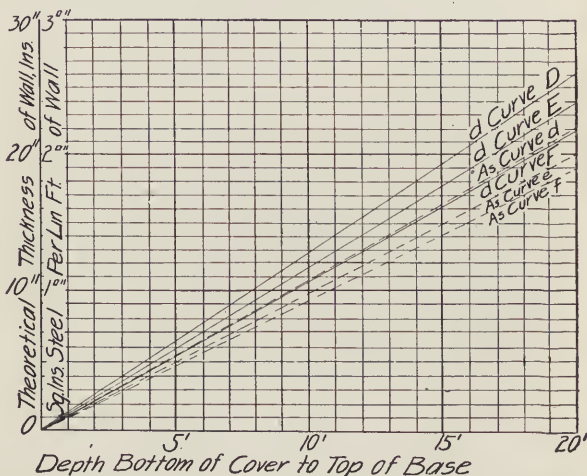

Fig. 131.—Diagram for the Design of Sidewalls for Box Culverts.

used when the bank is between 30 and 40 ft. high and gives the theoretical thickness for various spans. Curve *d* is used when the bank is between 30 and 40 ft. high and gives the area of steel reinforcement per lin. ft. of side wall, while curves *E* and *e* and curves *F* and *f* correspond to the above under banks respectively 20 to 30 ft. high and 0 to 20 ft. high, each curve being calculated for the maximum height of bank. As in Fig. 130, the thickness of the side wall, *d*, should be increased $1\frac{1}{2}$ to 3 ins., sufficient to embed the bars.

It is customary to put either brackets or braces in the corners to take care of unequal pressures. The side rods should be bent inward at the top and extend through the thickness of both top and bottom. All rods should be hooked at each end.

When the fill comes below 3 ft. above the top of culvert the impact is figured at 100 per cent, and for large spans the live loads are assumed to be concentrated.

Cost of Concrete Culverts.—Mr. Colpitts* gives the following cost of retaining walls, abutments and box culverts, for the permanent way of the Kansas City Outer Belt & Electric Ry. These figures are of particular interest, for the variation in prices of materials during the two-year period while work was in progress and as giving the average cost of the work on the whole line as well as for individual structures. The culverts were all box culverts with wing walls and the abutments were for girder bridges. Walls and abutments were of L section with triangular or trapezoidal counterforts at the back between base slab and coping. The form work was thus rather complex.

All work was reinforced concrete, and was done by contract under the following conditions: The work of preparing foundations, including excavation, pile driving, diversions of streams, etc., was done by the railroad company, which also bore one-half the cost of keeping foundations dry while forms were being built and concrete placed. The railroad company also furnished the reinforcing bars at the site of each opening. The concrete work was let at \$9 per cu. yd., which figure covered all the labor and materials necessary to complete the work, other than the

*Railway Age, Aug. 2, 1907.

exceptions mentioned. The concrete proportions were 1-3-5. The cement used was Iola Portland and Atlas Portland. The sand was obtained from the bed of the Kansas River in Kansas City. The rock used was crushed limestone, passing a 2-in. ring and freed from dust by screening. Corrugated reinforcing bars, having an elastic limit of from 50,000 to 60,000 lbs. per sq. in., manufactured by the Expanded Metal & Corrugated Bar Co. of St. Louis, Mo., were used exclusively. The concrete in the smaller structures was mixed by hand, in the larger by a No. 1 Smith mixer. In the first structures built 2-in. form lumber was used, with 2x6-in. studs placed 3 ft. on centers. This was abandoned later for 1-in. lumber with 2x6-in. studs, 12 ins. on centers, and was found to be more satisfactory in producing a better face. The structures were built in the period from April, 1905, to May, 1907. Costs and wages were as follows:

Cement—

Per barrel at structure, April, 1905.....	\$1.25
Per barrel at structure, April, 1907.....	1.92
Average cost per barrel at mill.....	1.42
Freight per barrel.....	0.21
Hauling 1½ miles and storage.....	0.12
Average cost at structure.....	1.75
Average cost per cu. yd. concrete (1.1 bbls.).....	1.93

Sand—

Per cu. yd. at structure, April, 1905.....	\$0.625
Per cu. yd. at structure, April, 1907.....	0.75
Average cost per cu. yd., river bank.....	0.30
Freight per cu. yd.....	0.22
Hauling 1½ miles.....	0.20
Average cost at structure.....	0.72
Average cost per cu. yd. concrete (½ cu. yd.).....	0.36

Stone—

Per cu. yd. at structure, April, 1905.....	\$ 1.10
Per cu. yd. at structure, April, 1907.....	1.75
Average cost per cu. yd. at crusher.....	0.65
Hauling 4 miles.....	0.84
Average cost at structure.....	1.49
Average cost per cu. yd. concrete (0.9 cu. yd.).....	1.34

Lumber—

Per M. ft. at structure, April, 1905.....	\$15.00
Per M. ft. at structure, April, 1907.....	22.50
Average cost per M. at structure.....	19.00
Average cost per cu. yd. concrete.	0.49

Labor—

	Max.	Min.
Common labor, cts. per hour.....	20	17
Carpenters, cts. per hour.....	40	30

With these prices and wages the average cost of concrete work for the whole line was:

Item.	Per cu. yd.
Form building and removing.....	\$1.98
Mixing and placing concrete.....	0.74
Placing reinforcement	0.10
Wire, nails, water, etc.....	0.20
1.1 bbls. cement at \$1.75.....	1.93
½ cu. yd. sand at \$0.72.....	0.36
0.9 cu. yd. stone at \$1.49.....	1.34
Lumber for forms.....	0.49
Total	\$7.14

The following are the costs of specific structures built at different times:

Example I.—Indian Creek Culvert. 14x15 ft., 250 long, completed November, 1905:

	Per cu. yd.
Cement	\$1.37
Sand34
Stone	1.10
Labor	2.48
Lumber76
Miscellaneous18
Total	\$6.23

Example II.—Third Street Abutments and Retaining Wall. Completed November, 1906:

	Per cu. yd.
Cement	\$1.78
Sand35
Stone	1.35
Lumber74
Labor	2.75
Miscellaneous16
Total	\$7.13

Example III.—Abutments, Overhead Crossing with Union Pacific and Rock Island. Completed May, 1907:

	Per cu. yd.
Cement	\$1.92
Sand32
Stone	1.74
Lumber98
Labor	2.96
Miscellaneous16
Total	\$8.08

EXAMPLES OF ARCH CULVERTS.

Reinforced concrete culverts have been adopted as standard by several American railroads, and while practical experience may tend to reduce dimensions more in conformity with theoretical research and foreign practice, a few examples will illustrate recent application of concrete steel in culvert construction.

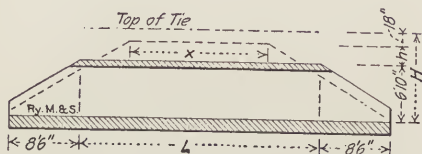

Fig. 132.—Standard Arch Culverts for Inside Dimensions of 4x4 ft., 5x5 ft., and 6x6 ft., C., B. & Q. Ry.

Standard Arch Culverts, C., B. & Q. R. R.—Fig. 132 illustrates standard arch culverts adopted by the C., B. & Q. R. R., in which

$$L = \frac{10}{3}h + x + 4 \text{ ft.} \dots\dots\dots (51)$$

where x = width of the roadbed at the crown, the other quantities being as shown in Fig. 132.

Table LXV gives various dimensions for this type of culvert.

TABLE LXV.—DIMENSIONS AND MATERIALS FOR STANDARD ARCH
CULVERTS, C., B. & Q. R. R.

Inside dimensions in feet.	Length of wing walls, ft. ins.	Cu. yds. concrete wing walls.	Cu. yds. lin. ft. of barrel.	Lbs. metal, wing walls.	Lbs. metal, lin. ft. of barrel.
4 x 4	5-3	6	0.5	236	54
5 x 5	6-11	10	0.71	401.7	76.7
6 x 6	8-6	12	1.00	553.5	103.4

Arch Culvert, Kalamazoo, Mich.—Fig. 133 illustrates a culvert of 9 ft. 10 ins. span and 1,080 ft. long built at Kalamazoo, Mich. The reinforcement consists of woven steel wire fabric of No. 11 wire laid in two layers each, at the intrado, extrado and invert as indicated in the drawing. The total length of

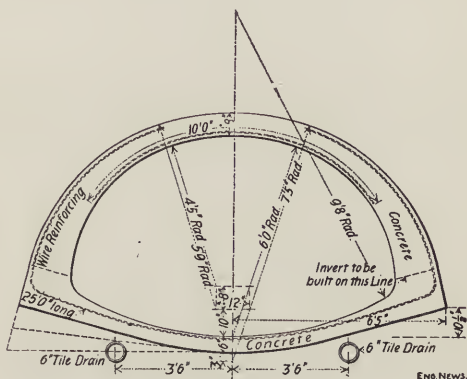

Fig. 133.—Arch Culvert at Kalamazoo, Mich.

fabric surrounding the culvert in one section is 175 ft. There is an average of 5 wires per linear foot enclosing the culvert except where the inner and outer reinforcement overlaps. The bearing portion of the concrete in the inverted arch was changed in form as shown in the drawing by dotted lines, according to the character of the soil. Where quicksand was encountered two

6-in. tile drains were laid under the invert and these by removing the excess of water from the quicksand made it a firm and good foundation. The use of a wire fabric as reinforcement is a safeguard against mistakes or omissions in placing the reinforcement during construction.

Arch Culvert, Great Northern Ry.—A reinforced concrete arch culvert of large span* is shown in Fig. 134. The plans were calculated for heights of bank of both 22 and 40 ft., weight of fill being taken at 100 lbs. per cu. ft. A uniform live load of 10,000 lbs. per lin. ft. of track was assumed, 50 per cent added for impact, a factor of safety of 4 used on such live load plus impact, and of 2 on dead load. The figures for the ultimate strength of concrete in tension, compression and shear were 200, 2,000, and 400 lbs. respectively. Modulus of elasticity of concrete in compression was taken at 3,000,000 lbs. per sq. in., elastic limit of the corrugated bar reinforcement, 50,000 lbs. per sq. in., and weight of concrete, 150 lbs. per cu. ft.

It was found that the plans shown in Fig. 134 could be used for a fill of 50 or even 60 ft. without changing them appreciably. It was also found that, so far as quantities are concerned, reinforced concrete arch culverts are more economical than those of the box pattern for any span exceeding 6 ft. The form work for an arch culvert is more expensive than for one of the box shape, but the extra expense is not believed to be large enough to justify the adoption of the latter style of structure for spans exceeding 6 ft.

Table LXVI contains quantities of concrete and steel for culverts similar to Fig. 134, also for pipe and box culverts. As compared with quantities contained in plain concrete culverts as commonly built and accepted as good practice in this country, a marked difference is seen to exist. Thus, the 8x8 ft. reinforced concrete arch culvert, contains 1.37 cu. yds. of concrete and 158 lbs. of steel per linear foot of barrel, which steel, figured at $3\frac{1}{2}$ cts. in place, is equivalent to 0.69 cu. yd. of concrete when the latter is taken at \$8.00 per cu. yd. in place. The total equivalent concrete yardage is then $1.37 + 0.69 = 2.06$ cu. yds.

* C. F. Graff, C. E., Engineering News. Vol. LV, No. 1.

per lin. ft. of barrel. As against this we have in plain concrete culverts of the same span and of usual standard designs from 3 to 4 cu. yds. Also, in this particular culvert, one pair of wing walls is observed to contain 11.22 cu. yds. of concrete and 793 lbs. of steel, or a total equivalent concrete quantity of $11.22 + 3.47 = 14.69$ cu. yds. of concrete, as against 40 to 50 cu. yds. in ordinary plain concrete construction.

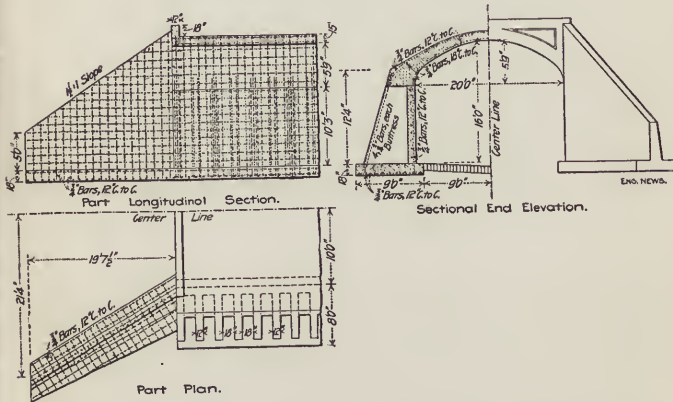

Fig. 134.—Reinforced Concrete Arch Culvert of 20-Ft. Span.

TABLE LXVI.—DIMENSIONS AND MATERIALS FOR REINFORCED CONCRETE
CULVERTS, G. N. Ry.

Size, ft. in.	Barrel per lin. ft.			One Pair Wing Walls.			Remarks.
	Concrete cu. yds.	Steel, pounds.	Paving, cu. yds.	Concrete cu. yds.	Steel, pounds.	Paving, cu. yds.	
2 x 0	0.10	5	Pipe Culvert
3 x 0	0.23	10	" "
4 x 0	0.30	12	" "
4 x 4	0.54	61	2.38	141	Box
4 x 6	0.72	73	2.50	128	Arch
6 x 6	0.86	116	5.16	397	" "
8 x 8	1.37	158	11.22	793	" "
12 x 12	2.78	237	37.25	1,850	" "
17 x 16	3.70	287	51.80	2,579	" "
16 x 20	5.00	300	0.66	45.60	2,143	20.2	" "
16 x 20	5.05	307	46.02	2,277	" "

EXAMPLES OF BOX CULVERTS.

Standard Box Culverts, C., B. & Q. R. R.—Fig. 135 and Table LXVII give dimensions and quantities of materials for culverts from 4x4 ft. to 7x8 ft., inside dimensions, and Fig. 136 and Table LXVIII give similar data for box culverts from 8x6

TABLE LXVII.—DIMENSIONS AND MATERIALS FOR STANDARD BOX CULVERTS, C., B. & Q. R. R.

Inside dimens. in ft.	Length of wing walls, ft. and ins.	Cu. yds. concrete wing walls.	Cu. yds. concrete lin. ft. barrel.	Thickness, side walls, in ins.	Thickness, roof slab, in ins.	Thickness, floor slab in ins.
4 x 4	5 10	7.4	0.75	12	12	12
4 x 5	7 6	9.2	0.83	12	12	12
4 x 6	9 2	11.6	0.9	12	12	12
5 x 4	6 1	9.0	0.91	12	14	14
5 x 5	7 9	11.3	0.99	12	14	14
5 x 6	9 6	13.9	1.06	12	14	14
6 x 5	8 0	13.5	1.18	12	16	16
6 x 6	8 0	16.5	1.25	12	16	16
6 x 8	12 9	18.3	1.60	15	16	16
7 x 5	8 4	15.65	1.39	12	18	18
7 x 7	11 5	24.9	1.72	15	18	18
7 x 8	13 0	29.13	1.82	15	18	18

TABLE LXVIII.—DIMENSIONS AND MATERIALS FOR STANDARD BOX CULVERTS, C., B. & Q. R. R.

Inside dimens. in ft.	Length of wing walls, ft. and ins.	Cu. yds. concrete wing walls.	Cu. yds. concrete lin. ft. of barrel.	Thickness, side walls, in ins.	Thickness, roof slab, in ins.	Thickness, floor slab, in ins.
8 x 6	10 0	31.0	1.89	15	20	20
8 x 8	13 4	39.7	2.08	15	20	20
8 x 10	10 5	57.1	2.51	18	20	20
10 x 10	17 0	62.3	3.07	18	24	24
10 x 12	20 4	76.0	3.3	18	24	24

ft. to 10x12 ft. inside dimensions, as adopted by the C., B. & Q. R. R. In Table LXVII, the formula for L is as follows:

$$L = \frac{10}{3}h + x + 3 \text{ ft.} \dots\dots\dots (52)$$

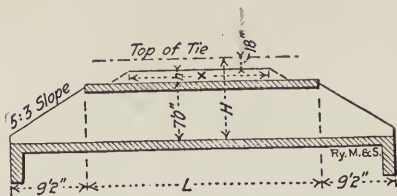

Fig. 135.—Standard Box Culvert for Clear Widths of 7 ft., C., B. & Q. Ry.

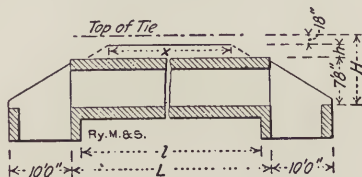

Fig. 136.—Standard Box Culvert for Clear Widths of 8 Ft. and over, C., B. & Q. Ry.

CONDUITS, SEWERS AND PIPES.

Erosive and Transporting Powers of Water.—The erosive power of water, or its power of overcoming cohesion, varies as the square of the velocity of the current.

The transporting power of a current varies as the sixth power of the velocity.

Hence a current running 3 ft. per second or about 2 miles per hour, will carry fragments of stone the size of a hen's egg or about 3 oz. in weight. A current of 3 miles an hour will carry fragments of 1½ tons, and a current of 20 miles an hour will carry fragments of 100 tons.

The transporting power of water must not be confounded with its erosive power. The resistance to be overcome in the one case is weight, in the other cohesion; the latter varies as the square, the former as the sixth power of the velocity.

Resistance of Soil to Erosion by Water.—Prof. W. A. Burr in "Engineering News," Feb. 8, 1894, gives a diagram showing the resistance of various soils to erosion by flowing water. The following figures show the comparative resistance:

Pure sand resists erosion by flow of 1.1 ft. per second.

Sand soil, 15 per cent clay, 1.2 ft. per second.

Sandy loam, 40 per cent clay, 1.8 ft. per second.

Loamy soil, 65 per cent clay, 3 ft. per second.

Clay loam, 85 per cent clay, 4.8 ft. per second.

Agricultural clay, 95 per cent clay, 6.2 ft. per second.

Clay, 7.35 ft. per second.

Kutter's Formula.—Kutter's formula for velocity of water in conduits is as follows:

$$v = \left\{ \frac{\frac{1.811}{n} + 41.6 + \frac{0.00281}{s}}{1 + \left(\frac{41.6 + 0.00281}{s} \right) \times \frac{n}{\sqrt{r}}} \right\} \sqrt{rs} \dots \dots \dots (53)$$

in which

v = mean velocity in ft. per second

$r = \frac{a}{p}$ = hydraulic mean depth in feet

a = area of cross section in sq. ft.

p = wetted perimeter in linear feet

$s = \frac{h}{l}$ = sine of slope, or the fall of a given distance divided by said distance.

n = a coefficient, depending on the nature of the lining or surface of the channel

If we call

$$c = \left\{ \frac{\frac{1.811}{n} + 41.6 + \frac{0.00281}{s}}{1 + \left(\frac{41.6 + 0.00281}{s} \right) \frac{n}{\sqrt{r}}} \right\}$$

we have

$$v = c \sqrt{rs} = c \sqrt{r} \sqrt{s} \dots \dots \dots (54)$$

which is Chezy's formula. Table LXIX for the flow of water in pipes is based upon Kutter's formula.

Since n varies with the roughness of the surface of the chan-

CULVERTS, CONDUITS, SEWERS, DAMS. 265

TABLE LXIX.—FLOW OF WATER IN CIRCULAR PIPES, SEWERS, ETC.,
FLOWING FULL.

Based on Kutter's Formula, with $n = .013$.

Slope is head divided by length of pipes.

(From Kent.)

Diam.	Discharge in cubic feet per second for varying slopes.							
Slope ...	1 in 100	1 in 200	1 in 300	1 in 400	1 in 500	1 in 600	1 in 700	1 in 800
15 in. ...	6.18	4.37	3.57	3.09	2.77	2.52	2.34	2.19
16 " ...	7.38	5.22	4.26	3.69	3.30	3.01	2.79	2.61
18 " ...	10.21	7.22	5.89	5.10	4.56	4.17	3.86	3.61
20 " ...	13.65	9.65	7.88	6.82	6.10	5.57	5.16	4.83
22 " ...	17.71	12.52	10.22	8.85	7.92	7.23	6.69	6.26
Slope ..	1 in 200	1 in 400	1 in 600	1 in 800	1 in 1000	1 in 1250	1 in 1500	1 in 1800
2 ft. 0 in.	15.88	11.23	9.17	7.94	7.10	6.35	5.80	5.29
2 " 2 "	19.73	13.96	11.39	9.87	8.82	7.89	7.20	6.58
2 " 4 "	24.15	17.07	13.94	12.07	10.80	9.66	8.82	8.05
2 " 6 "	29.08	20.56	16.79	14.54	13.00	11.63	10.62	9.69
2 " 8 "	34.71	24.54	20.04	17.35	15.52	13.88	12.67	11.57
Slope ..	1 in 500	1 in 750	1 in 1000	1 in 1250	1 in 1500	1 in 1750	1 in 2000	1 in 2500
2 ft. 10 in.	25.84	21.10	18.27	16.34	14.92	13.81	12.92	11.55
3 " 0 "	30.14	24.61	21.31	19.06	17.40	16.11	15.07	13.48
3 " 2 "	34.90	28.50	24.68	22.07	20.15	18.66	17.45	15.61
3 " 4 "	40.08	32.72	28.34	25.35	23.14	21.42	20.04	17.93
3 " 6 "	45.66	37.28	32.28	28.87	26.36	24.40	22.83	20.41
Slope ..	1 in 500	1 in 705	1 in 1000	1 in 1250	1 in 1500	1 in 1750	1 in 2000	1 in 2500
3 ft. 8 in.	51.74	42.52	36.59	32.72	29.87	27.66	25.87	23.14
3 " 10 "	58.36	47.65	41.27	36.91	33.69	31.20	29.18	26.10
4 " 0 "	65.47	53.46	46.30	41.41	37.80	34.50	32.74	29.28
4 " 6 "	89.75	73.28	63.47	56.76	51.82	47.97	44.88	40.14
5 " 0 "	118.9	97.09	84.08	75.21	68.65	63.56	59.46	53.18
Slope ..	1 in 750	1 in 1000	1 in 1500	1 in 2000	1 in 2500	1 in 3000	1 in 3500	1 in 4000
5 ft. 6 in.	125.2	108.4	88.54	76.67	68.58	62.60	57.96	54.21
6 " 0 "	157.8	136.7	111.6	96.66	86.45	78.92	73.07	68.35
6 " 6 "	195.0	168.8	137.9	119.4	106.8	97.49	90.26	84.43
7 " 0 "	327.7	205.9	168.1	145.6	130.2	118.8	110.00	102.9
7 " 6 "	285.3	247.1	201.7	174.7	156.3	142.6	132.1	123.5
Slope ..	1 in 1500	1 in 2000	1 in 2500	1 in 3000	1 in 3500	1 in 4000	1 in 4500	1 in 5000
8 ft. 0 in.	239.4	207.3	195.4	169.3	156.7	146.6	138.2	131.1
8 " 6 "	281.1	243.5	217.8	198.8	184.0	172.2	162.3	154.0
9 " 0 "	327.0	283.1	253.3	231.2	214.0	200.2	188.7	179.1
9 " 6 "	376.9	326.4	291.9	266.5	246.7	230.8	217.6	206.4
10 " 0 "	431.4	373.6	334.1	305.0	282.4	264.2	249.1	236.3

For U. S. gallons, multiply the figures in the table by 7.4805.

For a given diameter the quantity of flow varies as the square root of the sine of the slope. By using this principle the flow for other slopes than those given in the table may be found.

nel, we are here interested only in that value of n relating to concretè. The value is

$$n = 0.013,$$

which gives the values in Table LXX for c , when

$$s \geq 0.001,$$

From this table the velocity, and hence the quantity, of water flowing in any pipe may be determined.

TABLE LXX.—VALUES FOR c IN CHEZY'S FORMULA.
(From Kent.)

$n = 0.013.$			
Diam. in ft.	c	Diam. in ft.	c
0.5	69.5	8.	130.4
1.0	85.3	9.	132.7
1.5	94.4	10.	134.5
2.	101.1	11.	136.2
3.	110.1	12.	137.7
4.	116.5	14.	140.4
5.	121.1	16.	142.1
6.	124.8	18.	144.4
7.	127.9	20.	146.

Grade of Sewers.—The correct limit of grades which can be flushed, 0.1 to 0.2 per cent, may be assumed for sewers which are sometimes dry, while 0.3 per cent is allowable for the trunk sewers in large cities. Sewers should run dry as rarely as possible.

Calculations.—For conduits the calculations are somewhat complex owing to varying conditions and uncertain stresses, as consideration must be given to eventual future superimposed loads. The maximum live load with its impact in addition to the weight of the backfill should be taken to find the maximum stress, although the actual stress in most cases will be considerably less. Here the judgment of the designer must be used.

Calculation for Internal Pressure.—For internal pressure the calculation is as follows:

- Let p_0 = internal pressure lbs. per sq. in.
- d = diameter of conduit in inches.
- A_s = area of steel reinforcement per lin. ft. in \bar{s} sq. in.
- f = unit stress in steel reinforcement.

If concrete is to take no part of the tension, we have

$$fA_s = \frac{p_0 d}{2}$$

or

$$A_s = \frac{p_0 d}{2f}$$

Longitudinal reinforcement is provided for bending and temperature stresses. For bending moments the pipe is calculated like a beam and for temperature stresses the author allows about 1/500 of the area of the shell similarly as for retaining walls, but for conduits the range of maximum and minimum temperature is considerably less. For small pipes running over a long distance, expansion joints should be provided similar to those in use for iron pipes, particularly where the back fill is shallow and the range of temperature great.

Calculation for External Pressure.—For large pipes or conduits the regular arch calculation becomes necessary, whereby the pressure line is traced and abutments determined.

For smaller pipe it has been found sufficient to calculate the external live and dead load per linear foot and make the combined thickness of the two sides of the shell sufficiently large so that the resulting compression is taken by the concrete alone. Reinforcement in the form of a fabric or a rod netting is then added to provide for bending moments and temperature stresses.

Weld's Formula.—A good approximate empirical formula is furnished by Mr. F. Weld, C. E., as follows:

Let t = thickness of shell in inches.

d = diameter of span in feet.

LL = live load in lbs. per sq. ft., allowing for impact.

DL = dead load in lbs. per sq. ft. at section to be examined.

$$\text{then } t = \sqrt{d} + \frac{d}{10} + \frac{LL}{200} + \frac{DL}{400} \dots\dots\dots (55)$$

Example.—Design a pipe, having given the following data:

Internal diameter of pipe = 6 ft. 6 ins.

Slope = 1 in 500.

Length of pipe = 10,000 ft.

Average fill = 10 ft. above top.

Maximum live load = 200 lbs. per sq. ft.

Internal Pressure.—

$$\text{Head} = \frac{10,000}{500} = 20 \text{ ft.}$$

$$fA_s = \frac{p_o d}{2} = \frac{20 \times 62.4 \times 6.5}{2} = 4056 \text{ lbs.}$$

$$A_s = \frac{4056}{30,000} = 0.1352 \text{ sq. in.}$$

We take f at 30,000 lbs. per sq. in., representing high carbon fabric of 80,000 lbs. elastic limit. No. 7 wire = .0246 sq. ins. or for 4-in. centers $3 \times 0.0246 = .0738$ sq. ins., hence two layers of 4x6-in. mesh fabric No. 7 and No. 11 wire are sufficient.

For practical reasons it is a good rule not to make the shell thinner than $1/12$ diameter.

Hence

$$t = \frac{6.5 \times 12}{12} = 6\frac{1}{2} \text{ ins.}$$

External Pressure.—

Taking the zero load line at $\frac{1}{2}$ to 1, we have approximately

$$LL = 200 \left(7.5 + \frac{14}{2} \right) = 2900$$

$$DL = 10 \times 100 \left(7.5 + \frac{14}{2} \right) = 14500$$

$$LL + DL = 17,400 \text{ lbs. per lin. ft. of pipe.}$$

Even if we do not stress the concrete more than 250 lbs. per sq. inch, we get

$$t = \frac{17400}{2 \times 250} = 3\frac{1}{2} \text{ ins.}$$

According to Weid's formula we get

$$\begin{aligned} t &= \sqrt{d} + \frac{d}{10} + \frac{LL}{200} + \frac{DL}{400} \\ &= \sqrt{6.5} + \frac{6.5}{10} + \frac{200}{200} + \frac{1000}{400} \\ &= 6.7 \text{ ins., while } 5 \text{ ins. is about right.} \end{aligned}$$

$A_s = 5 \times 12 \times 0.007 = 0.420$ sq. ins. per lin. ft., or use the same fabric as above with $\frac{1}{2}$ -in. rods 18 ins. on centers wired to each fabric.

By investigating the bending moments, according to Prof. Talbot's formulas (see page 98), more exact results are obtained than by the above approximate and empirical method.

Reinforcement for Sewers.—If one set of reinforcement is used, $\frac{1}{2}$ per cent of the shell area usually is sufficient. If two sets of reinforcement are used, one at intrado and one at extrado, $\frac{3}{4}$ per cent is usually employed. For circular pipes the thickness for constructive reasons usually is made constant. For longitudinal or distributing rods the author uses one-half the area of carrying rods, spacing them 50 per cent further apart. If the annular or carrying rods are separate, they are spliced by lapping or hooking. In either case all rods should have hooked ends. If the reinforcement is spiral, the ends of the helices are hooked, overlapping 40 diameters and tied together by means of No. 18 annealed wire.

The carrying and distributing rods are likewise tied together at crossings, so as to keep them stiff and in their proper position during concreting.

In most instances a high carbon fabric will be found most economical for conduit reinforcement. The author has used for this purpose a 4x6-in. fabric No. 5 x No. 11, No. 7 x No. 11, or No. 9 x No. 11 wire of high tensile strength.

In many instances one or two layers of this fabric are sufficient; if not, $\frac{1}{2}$ in. or $\frac{5}{8}$ in. steel rods are tied to the fabric where required.

A conduit located in an arch fill is stressed according to the line of a parabola and if built according to this line can be of

remarkably light dimensions and still withstand a very heavy uniform load.

Such conduits must of course be carefully back filled, but after filling there is little danger of damaging them.

Thickness and Weight of Reinforced Concrete Pipe.—Table LXXI gives a list of light weight reinforced concrete sewer pipe as manufactured in Germany and Austria.

TABLE LXXI.—THICKNESS AND WEIGHT OF CONCRETE PIPE.

Circular pipe.			Egg-shaped pipe.		
Diam. in inches.	Thickness inches.	Wt. per lin. ft. in lbs.	Diam. in inches.	Thickness inches.	Wt. per lin. ft. in lbs.
4	$\frac{3}{8}$	9½	7 x 11	$\frac{3}{8}$	23
6	$\frac{3}{8}$	11½	10 x 15	$\frac{3}{8}$	33
8	$\frac{3}{8}$	17	12 x 18	1	46
10	$\frac{3}{8}$	24	14 x 21	1	52
12	$\frac{3}{8}$	30	16 x 24	1	67
14	$\frac{3}{8}$	37	20 x 30	1½	87
16	$\frac{3}{8}$	44	22 x 33	1½	105
18	1	50	24 x 36	1½	110
20	1½	60	25 x 37½	1½	120
22	1½	67	28 x 42	1½	127
27	1½	100	29 x 43	1½	140
33	1½	146	31 x 47	1½	173
43	2½	224	40 x 60	2	266
55	2½	335	51 x 80	2½	366
63	2½	426			
75	3	580			

Stresses in Pipes and Rings According to Talbot's Researches.—Prof. A. N. Talbot gives the following data in his paper on results of tests of cast iron and concrete pipes (Bulletin No. 22, University of Illinois Experiment Station, Urbana, Ill., April 29, 1908):

Concentrated Load.—For a concentrated load, Q applied at the crown of a ring, the bending moment M_B for a pipe of mean external diameter D is

$$M_B = 0.159 QD$$

The resisting moment is

$$M_R = \frac{1}{6} Ct^3$$

where C = unit stress at the most remote fiber

t = thickness of the ring.

Distributed Vertical Load.—For a distributed vertical load on thin elastic ring, the determination of the values of M_A and M_B is given as follows (see Fig. 137):

If a system of horizontal forces equal to the vertical forces here considered be applied to a ring, the bending moment produced at A by the horizontal forces will be the same as that produced at B with the vertical load, and the bending moment produced at B will be the same as that found at A with a vertical load, but with opposite signs in each case.

Similarly, at any point between A and B it is evident that an equal numerical bending moment will be produced with the new loading as at corresponding points with the old loading, but with opposite signs. The effect of a combination of the vertical and horizontal loads will be the same as that of a load normal to every part of the ring and making the bending moment at every section zero.

It follows then that

$$M_A = M_B = \frac{WD}{16}$$

where W = the total distributed load on a ring of unit length, and D the mean diameter of the ring.

Taking $\phi = 45^\circ$ the bending moment above this point of the ring is positive, below it is negative.

Distributed Vertical and Horizontal Load.—In thin elastic ring it is found that

$$M_B = -M_A = \frac{wr^2}{4}(1 - q) \dots \dots \dots (56)$$

where

$2r$ = average diameter of ring.

q = the ratio of the horizontal to the vertical pressure.

The bending moment becomes zero at $\phi = 45^\circ$, as in the other case.

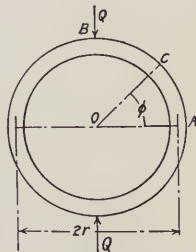

Fig. 137.

If the horizontal pressure has the same value as the vertical pressure, $q = 1$ and M becomes zero at all points. This corresponds to a uniform external pressure and produces equal compression in all parts of the ring.

Thus for a concentrated load we have for the most remote fiber

$$f = \frac{Q}{t} \pm \frac{0.091QD}{\frac{1}{8}t^2} \dots\dots\dots (57)$$

At any point of the ring forming an angle ϕ with the horizontal, we have:

$$f = \frac{1}{2} \frac{Q \cos \phi}{t} \pm \frac{M}{\frac{1}{8}t^2} \dots\dots\dots (58)$$

For a uniformly distributed horizontal load the stress at the crown B will be

$$f = \frac{1}{16} \frac{WD}{\frac{1}{8}t^2} \dots\dots\dots (59)$$

At A ,

$$f = \frac{1}{2} \frac{W}{t} - \frac{3}{8} \frac{WD}{t^2} \dots\dots\dots (60)$$

and at any given point,

$$f = \frac{wr \cos^2 \phi}{t} \pm \frac{M}{\frac{1}{8}t^2} \dots\dots\dots (61)$$

For a distributed horizontal and vertical load, we have at the crown B ,

$$f = \frac{qwr}{t} \pm \frac{1}{16} \frac{WD}{\frac{1}{8}t^2} \dots\dots\dots (62)$$

At A , the extremity of the horizontal diameter,

$$f = \frac{wr}{t} \pm \frac{1}{16} \frac{WD}{\frac{1}{8}t^2} \dots\dots\dots (63)$$

and at any given point,

$$f = \frac{wr \cos^2 \phi}{t} - \frac{qwr \sin^2 \phi}{t} \pm \frac{M}{\frac{1}{8}t^2} \dots\dots\dots (64)$$

These conditions are not strictly true for reinforced concrete.

As the amount of reinforcement is usually lower than that in which the circular beam would fail by compression in the concrete, we may take for the resisting moment of the reinforced concrete section

$$M_r = 0.87 A_s f d \dots\dots\dots (65)$$

where A_s is area of cross section of reinforcement for unit length of ring.

d = distance from compression face to center of steel reinforcement.

f = tensile stress in steel due to bending moment.

The actual tensile stress in the steel at A , the extremity of the horizontal diameter, is

$$f' = f - \frac{\frac{1}{2} n T}{t(1 + np)} \dots\dots\dots (66)$$

being reduced by the resisting compressive stresses.

Here f is calculated by equating $0.87 A_s f d$ to the bending moment at the section considered.

p = ratio of area of reinforcement for a unit length of beam or ring to the distance between the center of the steel and the compression face of the concrete.

T = the thrust or pressure against the face of the section and

n = the ratio of the moduli of elasticity, which for this purpose may be taken as 15. At the extremity of the horizontal diameter,

$$T = \frac{W}{2} \dots\dots\dots (67)$$

and at the crown it is zero for vertical loading, and for both concentrated and distributed load the greatest tensile stress is found in this section.

Summary of Tests Made on Concrete Pipes.*—(1) The reinforced concrete rings in the concentrated load test held their maximum loads through a considerable deflection, thus showing a quality which is of value when changes in earth conditions permit a gradual yielding of the surrounding earth. The calculated restraining moment agrees fairly well with the calculated bending moment.

(2) The reinforced concrete rings and pipes tested under distributed load made a satisfactory showing. The so-called critical failure may occur by either tension failure in the steel

*Prof. A. N. Talbot, Bulletin No. 22, University of Ill., Urbana, Ill.

or a diagonal tension failure (ordinarily called shearing failure) in the concrete. A flattened arc for the reinforcement where it approaches the inner face is of assistance, and stirrups may be of some value. Beyond the critical load the reinforcement is of service in distributing the cracks and in holding the concrete together. Final failure is by crushing of the concrete in much the same way as was obtained with plain concrete rings. The additional strength beyond the critical load may be taken into consideration in selecting the factor of safety or working strength.

(3) The restraint of the sand in the test is very important and the effect is to reduce the bending moment developed by a given vertical load or, as it would be commonly stated, to add strength to the pipe. The degree of permanency of this side restraint is uncertain. It seems evident in these tests that the distribution of the pressure, both horizontal and vertical, was not uniform, and that with the usual method of placing a pipe in an embankment and especially when other materials than sand are used, the distribution would be even less uniform than here found.

In view of this it will be well in making calculations and designs to use the formula

$$M_B = \frac{WD}{16}$$

for the bending moment, thus considering that the side of restraint is offset by the uneven distribution of the load, any surplus from this being considered merely as additional margin of safety.

For pipes poorly bedded and filled, a larger bending moment than $\frac{WD}{16}$ should be used.

(4) The method of bedding and laying pipes, the nature of the bed and the surrounding earth have a great effect upon the bending moment developed and upon the resistance of the pipe to failure.

If the greatest supported pressure comes at points well to the side of the bottom element, as may be obtained by careful

bedding, the bending moment is reduced. It is also plain that the bell should be left free from pressure at the bottom. It is possible that the presence of a bell detracts from the strength of a pipe. Any action in filling which increases the lateral restraint against the pipe will add to the security of the structure.

Forms for Sewers.—Forms for sewers are either of wood or metal, the patented forms being of metal. Fig. 138 shows a center for an 8-ft. conduit used in the Pittsburg filtration system.

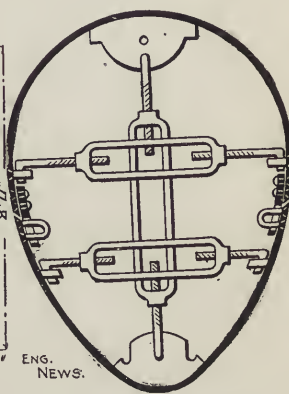
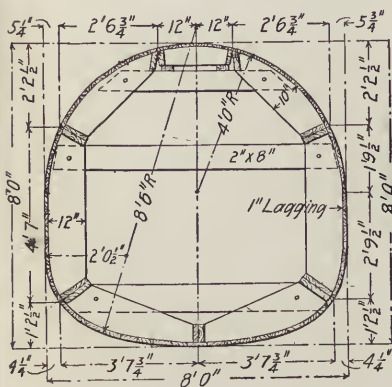

Fig. 138.—Center for 8-Ft. Conduit, Pittsburg Filtration System.

Fig. 139.—Blaw Collapsible Steel Centering for Sewers.

tem, so arranged that it can be easily taken apart, only bolts being used to assemble the form.

Fig. 139 shows a collapsible steel center patented by the Blaw Collapsible Steel Centering Co., Pittsburg. The operation of this centering is self explanatory.

Fig. 140 shows the method of using metal lagging for the form of a 13 1/2-ft. sewer, as patented by the Duralite Co., New York City. The lagging consists of two plain sheets of metal rigidly attached to an intermediate corrugated metal sheet. Fig. 140 shows the form for a sewer built to receive later a 4-in.

brick invert lining. In constructing this lagging for arch forms the outside steel sheet away from the concrete is replaced by narrow strips or bands which are bolted to the flat outside parts of the corrugated sheet. The spacing of the bolt holes in the bands determines the radius of the panel. One of the best adaptations of this form is in molds for sewers, conduits, etc., where it may be entirely self-supporting and does not require any inside bracing or studding. This obviates the adjustment of any

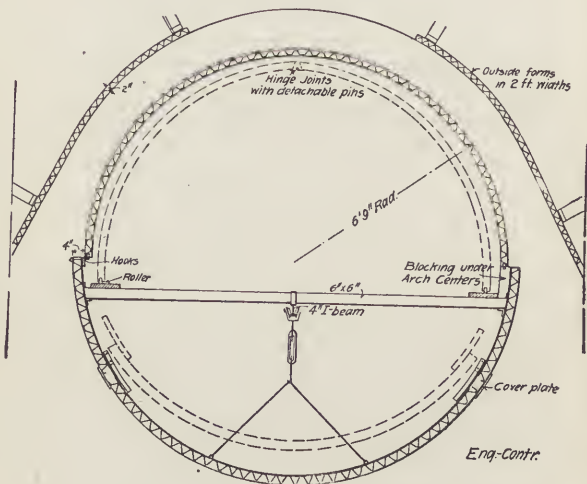

Fig. 140.—Metal Lagging for Form for 13½-Ft. Sewer.

moving parts in collapsing and moving forward, and leaves almost the entire cross-section of the bore clear for the workmen or for the operation of material cars in tunnel work. It has the added advantage that rear sections of the centering on which the masonry has taken its set can be collapsed, drawn through the forward sections where the masonry is being laid and set up in advance. This feature effects an economy of some 20 per cent to 40 per cent in the total feet of centering required

on continuous work. It also makes possible, where desired, absolute monolithic construction without vertical or horizontal joints.

DAMS.

Classification.—Dams are of two classes, (1) gravity or solid dams, where the water pressure tends to slide, rupture or overturn the dam, and (2) pressure dams or inclined dams, where the water pressure acts *with* the weight of the structure to assist its stability.

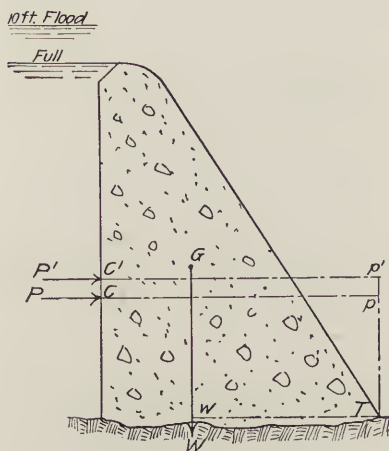

Fig. 141.—Forces Acting on a Solid Dam.

Comparative Features.—The method herein outlined for showing the comparative stresses in solid and pressure dams is the one used by the Ambursen Hydraulic Construction Co., Boston. In Fig. 141, which shows a solid dam, the water pressure is represented in intensity and direction by the line PC for a full dam and P_1C_1 for a 10-ft. overflow. The overturning moments about the toe T are, respectively:

$$M = PC \times pT \text{ and}$$

$$M_1 = P_1C_1 \times p_1T$$

showing that both pressure and leverage are increased by increased overflow. The moment of resistance M_R in either case is the weight of the dam W multiplied by the distance from toe to perpendicular through center of gravity.

The factor of safety is,

$$\frac{M}{M_R} \text{ or } \frac{M_1}{M_R}$$

as the case may be, and decreases rapidly as the water rises. Owing to the great cost of solid dams, this factor of safety is usually cut down to about 2.5.

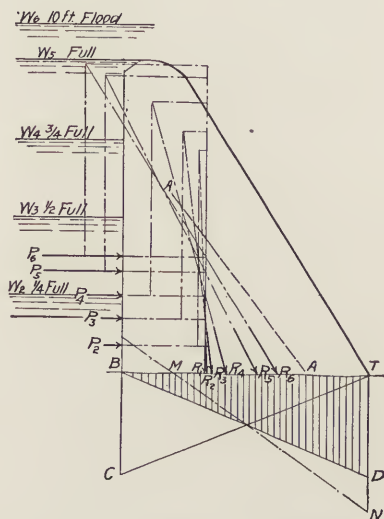

Fig. 142.—Resultants of Forces Acting on a Solid Dam.

The normal section of a reinforced concrete dam is triangular and thereby becomes a pressure dam, showing a far greater factor of safety, which increases with the depth of water.

Fig. 142 is the ordinary section of a solid dam. Its normal design is such that when empty the line of pressure cuts the up-

stream edge of the middle third at R_1 . As the dam fills up the resultants of the water pressure and the weight of the dam advance steadily and with increasing inclination down stream toward the toe, until when the calculated flood height is reached the resultant cuts the down stream edge of the middle third at R_6 . Under these conditions the distribution of pressure on the base is represented by the triangle $B T D$, there being no pressure at all at the heel and a maximum pressure at the toe. Now, if some extraordinary flood happens, the resultant will advance to $A A$, the distribution of pressures will be on $O N T$, the

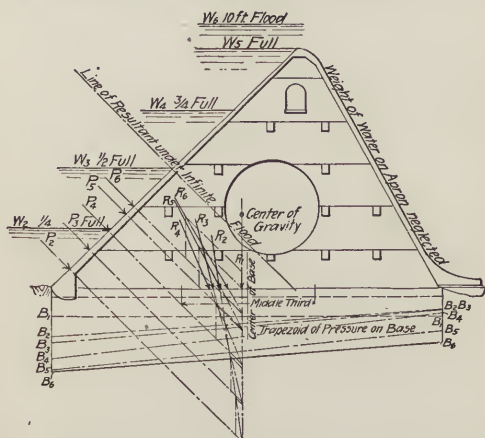

Fig. 143.—Resultants of Forces Acting on a Reinforced Concrete Dam.

virtual base of the dam will be reduced to $M T$, the dam will lift at the heel and the pressure at the toe of the dam will exceed the safe limit. So at a certain point the dam ruptures or is seriously weakened. By no chance, under working conditions, is the pressure ever where it ought to be namely, on the center of the base to give an equal distribution.

On the other hand, a dam having a triangular section behaves in an entirely different manner. Thus in Fig. 143 the pressure

resultant when empty is exactly at the center of the base. As the pond fills the resultants move *up stream* instead of down stream through the successive positions R_2 and R_3 until with the dam three-quarters full the resultant reaches the extreme position of R_4 , but even then not approaching the limit of the middle third. When the dam is full the resultant moves back towards the center to position R_5 , and under maximum flood it assumes the position R_6 , having returned nearly to the center. Under these conditions the base pressures are shown by the shaded trapezoid and are very nearly uniform in distribution. The excess of pressure is purposely thrown toward the heel of the dam where it receives the additional support of the cutoff wall.

The effect of the weight of the water flowing down the apron is not easy to calculate, but it is certain that it straightens up the resultant and moves it still nearer the center of the dam. Under maximum flood the pressure is substantially at the center of the dam and the distribution over the base is practically uniform. Hence, extraordinary floods, instead of increasing the risk to the dam, actually decrease it by forcing the resultant still nearer the center.

Pressure on the Immersed Surface.*—The usual method of finding the pressure on the immersed surface of a dam, the overturning moment and the resultant on the base, is illustrated in Fig. 144.

Let BC be the immersed surface, DC the base, BT the surface of the water, and x the depth of the water. Draw CK perpendicular to BC and equal to x ; then will the weight of the water in the prism BCK , of a length unity, be the amount of the pressure on the immersed surface one unit in length. This pressure P will act normal to the surface BC and through the center of gravity of the triangle BCK at G and will intersect BC at M , CM being equal to one-third of BC .

Find the center of gravity of the section of the dam $DABC$ and its weight W . From the intersection of P with the vertical

*Euel and Hill, "Reinforced Concrete."

BK'' perpendicular to BC from the crest and find the center of gravity of of $BK''K'C$. This may be done by locating the centers of gravity of the triangles ECK' , BCK and EBK'' at g , G and g' respectively, and that of the parallelogram $BKK'K''$ by the intersection of the diagonals at I , then the center of gravity of $BK''K'C$ will be at G' where gI intersects $g'g$ produced. The area of $BK''K'C$ is the difference of the areas of the triangles ECK' and EBK'' .

A force equal to the weight of $BCK'K''$, for a length unity, acting through G' normal to BC at M' will be the resultant pressure P' on a unit length of the surface BC .

Find the weight W' of a unit of length of the section of the dam and the pressure of water $AEFB$, over the crest, and the intersection of the vertical through the common center of gravity with P' at N' , and lay off $N'O'$ vertical and equal to W' .

Draw $O'S'$ parallel and equal to P' , then $S'N'$ will be the resultant R' , intersecting the base at q' . The values of P , W , R and the distance DQ' , given in Fig. 144, were found by assuming the following:

$$x = 15 \text{ ft.}$$

$$x' = 20 \text{ ft.}$$

$$DC = 15 \text{ ft.}$$

The batter of $AD = 3$ ft. in its height.

The crest $AB = 3$ ft.

The average weight of the prism of the dam = 140 lbs. per cu. ft., and the weight of water = 62.5 lbs. per cu. ft.

For P , W , R and DQ the water level is at ABT , and for P' , W' , R' , and DQ' the surface of the water is at EFT' .

Conclusion.—Dams are either designed as thin slabs supported on beams between counterforts, spacing the beams closer at the bottom and spreading them towards the top—or in the shape of a floor slab varying in thickness from bottom towards the top according to the water pressure.

Owing to the lighter weight of reinforced concrete dams, provision must be made to prevent them from sliding. This is

done by anchoring or filling the hollow space with sand and gravel or lean concrete.

Computing the dimensions of slabs, beams or counterforts is very simple after the pressures have been determined, and is done according to the methods laid down for floors and girders of buildings.

Types of Construction.—There are three principal types of construction—the open front dam, the half apron dam and the curtain dam.

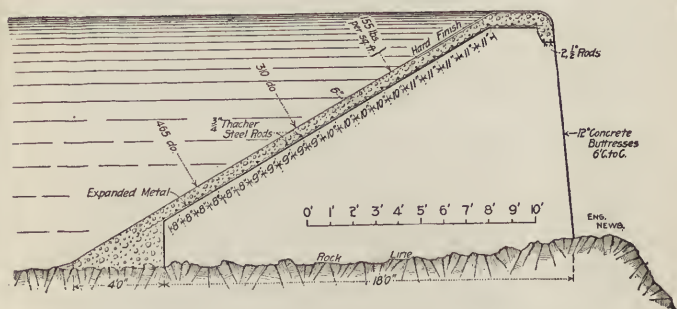

Fig. 145.—Reinforced Concrete Dam, Theresa, N. Y.

The Open Front Dam.—An example of this type of dam is the one built at Theresa, N. Y., shown in Fig. 145. This dam is built of concrete reinforced with Thacher rods and expanded metal; it is 120 ft. long and 11 ft. high and is founded on solid rock. The structure consists of a series of solid concrete buttresses 12 ins. thick and spaced 6 ft. apart center to center, and of a reinforced plate supported on the inclined tops of the buttresses. At the crest the plate is stiffened by a reinforced beam 6x8 ins. in section. The plate was made of concrete composed of 1 part Portland cement, 2 parts sand, and 4 parts broken limestone; the toe and buttresses were made of a 1-3-6 mixture. The buttresses were anchor-bolted to the rock by 3-ft. 1 1/4-in. bolts. The drawing shows the spacing of the rods and their di-

mensions. The dam is so constructed that the resultant pressure falls always within the base, and it is therefore a gravity dam under all heads of water. About 125 cu. yds. of concrete were required to construct the dam. It was constructed by the Ambursen Hydraulic Construction Co., Boston. The open front type is used for moderate heights, and when located on a ledge of hard rock is able to withstand the erosion from the overflow of water and ice.

The Half Apron Dam.—This type is a modification of the former and consists in carrying the apron down in front to within 6 or 8 ft. of the bottom, so curved as to discharge the water with a high velocity in a horizontal direction, as shown in Fig. 146.

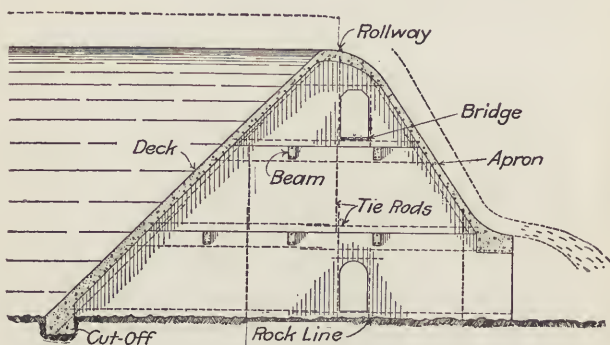

Fig. 146.—Half Apron Type of Dam.

The Curtain Dam.—This type goes still further and continues the apron to the river bed, entirely enclosing the interior, as illustrated in Fig. 147. It is customary to place vents in the apron just below the crest for the purpose of admitting air behind the sheet of water to destroy the partial vacuum which would otherwise form under high velocities of overflow during floods—and which is the cause of the so-called trembling of dams.

Where foundations are on hard clay or cemented sand, sheet piling is often driven at the heel and toe to a sufficient depth to insure tightness, and the concrete is placed over and about the head of the piling. Drain holes are placed in the toe to

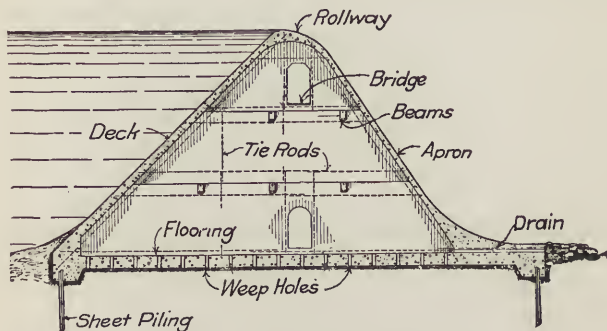

Fig. 147.—Curtain Type of Dam.

carry off seepage. Weep holes may be placed in the floor to prevent upward pressure on the floor, which might endanger the safety of the dam.

CHAPTER VI.

TANKS, RESERVOIRS, BINS AND GRAIN ELEVATORS.

TANKS AND RESERVOIRS.

General Discussion.—The construction of tanks and reservoirs in reinforced concrete is like pipes, in that it is one of the first applications of this material in building construction. Monier constructed a 42,000-gallon tank at Maisons-Alfort in 1868 and another of 23,000 gallons' capacity at Bougival in 1872 for the local water works. The number of reinforced concrete tanks already in existence is a proof of their fast increasing popularity.

Reinforced concrete is not only suitable and adapted for water storage, but likewise for wines, vinegar, petroleum, oil, and solid substances, such as grain, cement in bulk, coal, ore, ashes, etc. They are used for these purposes with great success in tanneries, distilleries, sugar refineries, breweries, paper mills, bleacheries, and other places where reservoirs are wanted for any purpose. Their cheapness, remarkable lightness and elasticity cause great reduction in the size and character of supports and foundations, and the minimum cost of maintenance and attention required has recommended reinforced concrete as an ideal material of construction for these various purposes.

Shape or Form of Tanks and Reservoirs.—For covered tanks the roofs assume the form of cones, domes, and spheres, or are also flat and calculated accordingly. The shape or form of the reservoirs may be round, elliptical, square, or polygonal, and the tanks may be located in, on, or above the ground, likewise supported on columns, walls, or girders, as the case may be. The cost largely depends upon the form, the cylindrical tanks being the more simple inasmuch as only the tension from

the interior pressure and the compression due to the weight of the walls and the roof must be considered, while in the rectangular or hexagonal structures the bending moments come prominently into consideration. If reservoirs are placed on the ground and subjected to compression from underneath, the spherical bottoms are concave and are turned downwards.

Calculations.—The calculations for circular tanks containing liquids are very simple.

Let T = tensile stress exerted on wall for 1 foot in height at a depth of h from the top.

A_s = area of steel required in 1 ft. of height.

d = diameter of tank in feet.

w = weight per cu. ft. of the liquid contained in the tank.

f_s = unit stress in the reinforcement.

h = depth of the tank at a point where the thickness is sought.

Then

$$T = \frac{dhw}{2} \dots\dots\dots (68)$$

$$A_s = \frac{T}{f_s} \dots\dots\dots (69)$$

Table Giving Capacity of Tanks.—Table LXXII gives the capacity in cubic feet and gallons for each 1 ft. depth of tanks of different diameters. To obtain the number of bushels capacity, multiply the number of cubic feet by 0.8. For example, a tank 12 ft. in diameter contains 113.10 cu. ft.; for each foot in height it would contain $113.10 \times 0.8 = 90.48$ bu.

Foundations.—Tank bottoms may rest on rock or hardpan and need be only of sufficient thickness to contain the reinforcement and insure proper connection with the side walls. On soft homogeneous ground, a layer of common concrete placed under the bottom is usually sufficient. Where the soil contains water under pressure, very careful calculations must be made to enable the bottom to withstand the buoyancy of the tank, and in these cases a rib or gridiron construction is often resorted to.

TABLE LXXII.—CAPACITY OF TANKS.

Diameter.	Cubic Ft.* for depth of 1 foot.	Gallons for depth of 1 foot.	Diameter.	Cubic Ft.* for depth of 1 foot.	Gallons for depth of 1 foot.	Diameter.	Cubic Ft.* for depth of 1 foot.	Gallons for depth of 1 foot.
ft. ins.			ft. ins.			ft.		
1 0	.785	5.87	5 0	19.63	146.88	33	855.30	6398.1
1 1	.922	6.89	5 3	21.65	161.93	34	907.92	6791.7
2 2	1.069	8.00	6 6	23.76	177.72	35	962.11	7197.1
3 3	1.227	9.18	6 9	25.97	194.25	36	1017.88	7614.3
4 4	1.396	10.44	6 0	28.27	211.51	37	1075.21	8043.1
5 5	1.576	11.79	3 3	30.68	229.50	38	1134.11	8483.8
6 6	1.767	13.22	6 3	33.18	248.23	39	1194.59	8936.2
7 7	1.969	14.73	9 9	35.78	267.69	40	1256.64	9400.5
8 8	2.182	16.32	7 0	38.48	287.88	41	1320.25	9876.2
9 9	2.405	17.99	3 3	41.28	308.81	42	1385.44	10363.9
10 10	2.640	19.75	6 6	44.18	330.48	43	1452.20	10863.2
11 11	2.885	21.58	9 9	47.17	352.88	44	1520.53	11374.4
2 0	3.142	23.50	8 0	50.27	376.01	45	1590.43	11897.3
1 1	3.409	25.50	3 3	53.46	399.88	46	1661.90	12431.9
2 2	3.687	27.58	6 6	56.75	424.48	47	1734.94	12978.3
3 3	3.976	29.74	9 9	60.13	449.82	48	1809.56	13536.5
4 4	4.276	31.99	9 0	63.62	475.89	49	1885.74	14106.4
5 5	4.587	34.31	3 3	67.20	502.70	50	1963.50	14688.0
6 6	4.909	36.72	6 6	70.88	530.24	51	2042.82	15281.4
7 7	5.241	39.21	9 9	74.66	558.51	52	2123.72	15886.5
8 8	5.585	41.78	10 0	78.54	587.52	53	2206.18	16503.4
9 9	5.940	44.43	6 6	86.59	647.74	54	2290.22	17132.1
10 10	6.305	47.16	11 0	95.03	710.90	55	2375.83	17772.5
11 11	6.681	49.98	6 6	103.87	776.99	56	2463.01	18424.6
3 0	7.069	52.88	12 0	113.10	846.0	57	2551.76	19088.5
1 1	7.467	55.86	6 6	122.72	918.0	58	2642.08	19764.2
2 2	7.876	58.92	13 0	132.73	992.9	59	2733.97	20451.6
3 3	8.296	62.06	6 6	143.14	1070.8	60	2827.43	21150.7
4 4	8.727	65.28	14 0	153.94	1151.5	61	2922.47	21861.6
5 5	9.168	68.58	6 6	165.13	1235.3	62	3019.07	22584.3
6 6	9.621	71.97	15 0	176.71	1321.9	63	3117.25	23318.7
7 7	10.085	75.44	16 0	201.06	1504.1	64	3216.99	24064.8
8 8	10.559	78.99	17 0	226.98	1697.9	65	3318.31	24822.7
9 9	11.045	82.62	18 0	254.47	1903.6	66	3421.19	25592.4
10 10	11.541	86.33	19 0	283.53	2120.9	67	3525.65	26373.8
11 11	12.048	90.13	20 0	314.16	2350.1	68	3631.68	27166.9
4 0	12.566	94.00	21 346.36	2591.0	69	3739.28	27971.8	
1 1	13.095	97.96	22 380.13	2843.6	70	3848.45	28788.5	
2 2	13.635	102.00	23 415.48	3108.0	71	3959.19	29616.9	
3 3	14.186	106.12	24 452.39	3384.1	72	4071.50	30457.0	
4 4	14.748	110.32	25 490.87	3672.0	73	4185.39	31308.9	
5 5	15.321	114.61	26 530.93	3971.6	74	4300.84	32172.6	
6 6	15.904	118.97	27 572.53	4283.0	75	4417.86	33048.0	
7 7	16.498	123.42	28 615.73	4606.2	76	4536.46	33935.2	
8 8	17.105	127.95	29 660.52	4941.0	77	4656.63	34834.1	
9 9	17.721	132.56	30 706.86	5287.7	78	4778.36	35744.7	
10 10	18.348	137.25	31 754.77	5646.1	79	4901.67	36667.1	
11 11	18.993	142.02	32 804.25	6016.2	80	5026.55	37601.3	

*Also area of circle in square feet.

Tightness of Tanks.—The question of tightness of the tanks is of the greatest importance and this is accomplished in various ways by different constructors. Often a tank is permitted to leak through its porous parts for several weeks, after which time the magnesia, lime, aluminum salts or impurities contained in the liquid will, to a great extent, close up the pores by silting. The author has found that the best method of making a tank tight is by hard troweling on the inside of the tank, such plastering being done before the final setting of the mortar or concrete of which the tank is constructed. The author

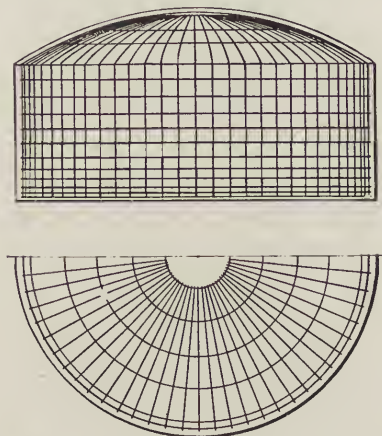

Fig. 148.—Reinforcement for Tanks.

prefers for tanks a rather dry mixture of 1 cement to 4 coarse sand well tamped. If a wet mixture is used, the mortar or concrete is apt to contract in setting, thereby causing initial compressive stresses in the steel reinforcement. When the tank is filled the concrete will crack in various places until the steel receives its tension stress. This is the common cause of leaky tanks, which must be plastered or painted afterwards.

Reinforcement.—The reinforcement of tanks consists of carrying and distributing rods, as indicated in Fig. 148, in which

the mesh and dimensions are proportioned to withstand the pressure and tension according to the head of liquid contained. The reinforcement is usually round rods, placed annularly round the tank either in separate circles or in helices, such reinforcement being closer together and stronger nearer the bottom of the tank, decreasing in area towards the top. The distributing rods are usually the same from the top to the bottom and equal to about $\frac{1}{2}$ per cent of the area of the tank wall.

For square tanks, reinforcement of the sides by brackets or buttresses usually on the inside becomes necessary, and the walls are then calculated as retaining walls supported on these brackets. When the tanks are not covered, a strong rib is usually run around the top construction, similar to the construction used in open steel tanks which are invariably strengthened and stiffened by riveting an angle iron around the top.

Cost.—The cost of reinforced concrete tanks built of light dimensions, but of rich material, resting on the ground and without roof, will be approximately as follows:

For 1,000 gallons' capacity.....	6 $\frac{1}{4}$ cts. per gallon
For 2,000 gallons' capacity.....	5 cts. per gallon
For 5,000 gallons' capacity.....	4 $\frac{1}{4}$ cts. per gallon
For 10,000 gallons' capacity.....	3 $\frac{1}{4}$ cts. per gallon
For 20,000 gallons' capacity.....	3 cts. per gallon
For 100,000 gallons' capacity.....	2 cts. per gallon
For 200,000 gallons' capacity.....	1 $\frac{3}{4}$ cts. per gallon

Tank for Montgomery Ward & Co., Chicago Heights, Ill.

—In 1901 the author constructed a 40-ft. tank, 8 ft. deep, for Montgomery Ward & Co., Chicago Heights. The tank is 5 ft. underground and 3 ft. above ground. A sump 1 ft. in diameter and 18 ins. deep was put at a point near the circumference and was kept empty by means of a hand pump, the water being conveyed away for a distance of about 100 ft. in a wooden trough. The walls and the roof are only 2 $\frac{1}{2}$ ins. thick, as shown in Fig. 149. A wire fabric of No. 9 wire, 1x6-in. mesh, was erected near the center of the wall, and reinforcing rods placed on the inside of the netting tied at the side by means of annealed wire.

be retained by the mesh. A few minutes later a second man threw on the next coat covering the mesh and the rods to a depth of $\frac{1}{2}$ in., and about half an hour later followed a third man with a third coat $\frac{1}{2}$ in. thick. After this coat was almost set the finisher followed up with a 1-2 mixture, which was troweled smooth with an iron tool. The last operation gave the tank a practically glossy surface on the inside similar to a sidewalk finish. As the wooden pegs were reached they were pushed

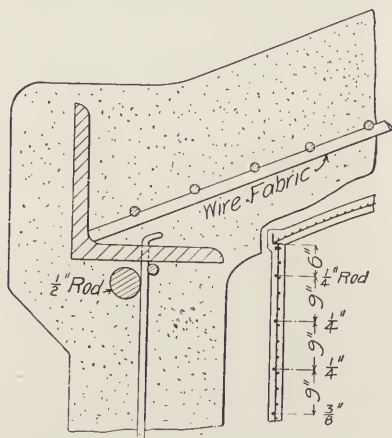

Fig. 150.—Detail of Connection at Roof, Tank for Montgomery Ward & Co.

into the earth and new pegs put in near the top. A form 3 ft. high made of $\frac{3}{4}$ -in. boards nailed to 2x6-in. ribs was then placed around the circumference and braced back on the ground and the plastering operation continued until the entire tank was plastered to the top, which took four plasterers and two helpers two days. An angle iron was laid around the top of the tank to take the thrust of the roof, and anchored by running the ends of the wire fabric through holes punched in the flange of the angle iron, as shown in Fig. 150. Then a conical form was erected

40 ft. in diameter and 4 ft. high at the apex to support the roof, the form being supported on studs set on planks laid on the bottom of the tank. The form consisted of 2x6-in. joists and $\frac{7}{8}$ -in. sheathing bent down on the radial joists. Wire fabric was laid on top of the form and tied to radial steel rods, which were run down to the angle iron and well heeled. An expanded

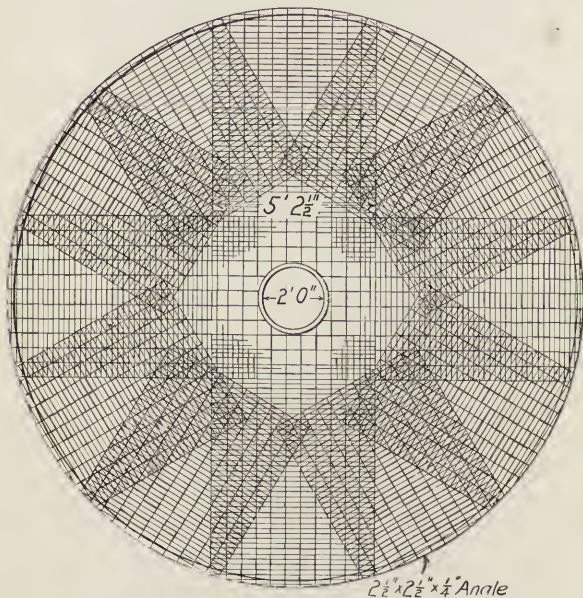

Fig. 152.—Plan of Fabric in Roof, Tank for American Steel & Wire Company.

metal apron was thrown over the angle iron and fastened to the wire netting of the sides, as well as the wire netting in the roof, so as to form a clinch for the mortar around the top corner. In Fig. 149 only the carrying rods, spaced 4 ins., are shown. The distributing rods of the fabric are spaced 1 in. apart. The roof was plastered $2\frac{1}{2}$ ins. thick in a manner simi-

lar to the one used for the sides. A manhole was left in the roof through which the forms were taken out. The sump was made tight by placing a nipple 18 ins. long with a flange at the lower end in the sump, and concrete placed around same under

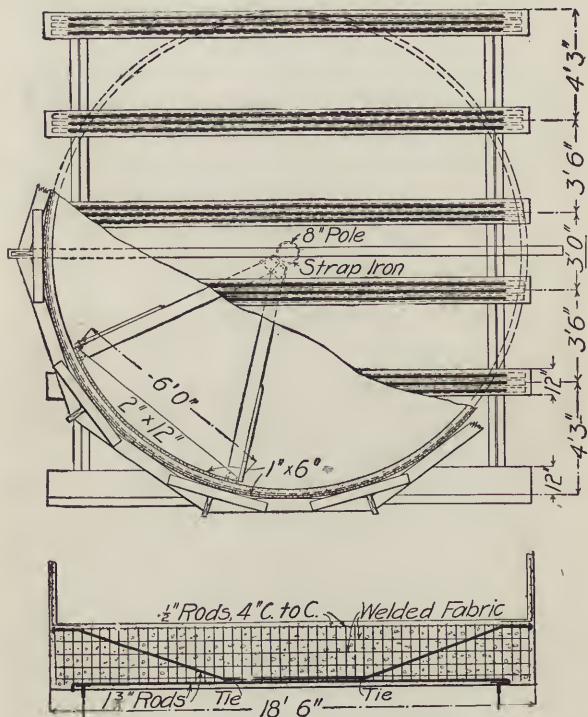

Fig. 153.—Falsework and Girders, Tank for American Steel & Wire Company.

continuous pumping, so that the space above the flange was kept dry until the concrete was set. Then a cap was placed over the upper end of the nipple in the tank. Thimbles were left in the tank for intake and discharge pipes. The cost of the



Fig. 154.—Construction of Intake Tank, LaSalle, Ill.

tank was about \$1,300.00, or 1.6 cts. per gallon, the remarkable cheapness being due to the fact that no forms were required for the sides, and that very little trouble was experienced with pumping.

Tank for American Steel & Wire Co., Cleveland, O.—Fig. 151 shows a cross-section and Fig. 152 the plan of a tank built by the author for the American Steel and Wire Company at the Emma Furnace, Cleveland, Ohio. This tank is 18 ft. in diameter and 24 ft. high, the sides being 3 ins. thick, the bottom 4 ins. and the roof 2½ ins. The capacity is 45,000 gallons, and it cost \$2,500.00, which is 5½ cts. per gallon. It was built in the winter, and the floor of the tank was on a pedestal 40 ft. above the ground. The floor consisted of girders shown in Fig. 153. The reinforcement consisted of an electrically welded fabric of 1x6-in. mesh used for distributing rods, and annular rings of from ¾ to ¼ ins. diameter steel for carrying rods, which were tied to the fabric every 9 ins. by means of No. 18 annealed wire. In the roof the sheets of fabric, 62½ ins. wide, overlapped one another and were carefully tied down by means of No. 18 wire.

After the tank was completed and filled with water a slight leakage was found in the side of the tank, but after one week had elapsed the tank was perfectly tight through silting.

Forms for an Intake Tank.—Fig. 154 shows how concrete was kept moist and also protected against freezing, in the construction of an intake tank, which was sunk into a river bank near La Salle, Ill., by the author some years ago. The tank, which consisted of a reinforced concrete cylinder, was jettied down as fast as it was built, the concreting being done at the same level while the tank was sinking. Fig. 155 shows the manner of raising the forms.

Battery Tanks.—The author has manufactured a large number of battery tanks, 4 ft. diameter by 6 ft. high, for block signal purposes on railroads. These tanks were 1½ ins. thick at bottom, sides and roof, with a manhole cover and frame. The reinforcement consisted of a wire fabric for the sides and ½-in. rods with wire fabric for the top and bottom. The mortar consisted of 1 Portland cement to 3½ coarse, sharp sand,



Fig. 155.—Manner of Raising Forms, Intake Tank, LaSalle, Ill.

and the tanks were plastered on collapsible inside molds, and made perfectly water-tight. Similar tanks are now manufactured by E. J. Winslow & Co., Chicago.

BINS AND GRAIN ELEVATORS.

The designing of grain elevators and storage structures is a specialty regarding which little literature is at hand, as it requires a practical knowledge not generally possessed by engineers. The author having had over 20 years' experience in the design and construction of grain elevators, and being the first designer of reinforced concrete grain elevators in the United States, here adds some remarks and suggestions relative to calculations and constructions in this special line, based upon experience of his own, as well as that of his confreres in elevator construction, which has come under his observation.

The researches and writings of Mr. J. A. Jamieson, the well-known elevator builder of Montreal, are particularly valuable and agree with the ideas of the author.

Action of Grain Flowing From a Bin.—If grain is allowed to run from a spout to a floor it will pile up until its slope reaches a certain angle called the angle of repose, when the grain will slide down the surface of the cone. If a hole be cut in the side of a bin the grain will flow out until the opening is blocked up by the outflowing grain. There is no tendency for the grain to spout up as in the case of fluids. If grain be allowed to flow from an opening it flows at a constant rate, which is independent of the head and varies approximately as the cube of the diameter of the orifice. The law of grain pressure has been studied by several engineers and as a result has been fairly well established.

Bridging Action of Grain in a Bin.—It has been found that in storing materials in bulk a certain bridging takes place to such an extent that at quiescent loads the lateral pressure becomes practically constant, and accordingly the weight of the contents of a bin partly rests on the bin walls.

Table of Grain Pressure.—Table LXXIII is taken from Mr. J. A. Jamieson's tests on the Canadian Northern elevator at

Port Arthur, Ont., which had cribbed wooden bins built of laminated planks, 2x6 ins. to 2x10 ins. The lateral and vertical pressures are given for heights to 65 ft.

TABLE LXXIII.—GRAIN PRESSURE IN DEEP BINS.*

Height in Feet.	Lateral Pressure in Lbs.		Vertical Pressure in Lbs.		Height in Feet.
	Per sq. in.	Total per ft. section.	Per sq. in.	Wt. on bottom.	
1			.347	8,900	1
2			.67	17,152	2
3	0.22	1,690	.95	24,320	3
4	0.43	3,302	1.21	30,916	4
5	0.61	4,685	1.45	37,120	5
6	0.80	6,144	1.67	42,752	6
7	0.95	7,296	1.87	47,872	7
8	1.08	8,294	2.05	52,480	8
9	1.19	9,139	2.22	56,832	9
10	1.28	9,830	2.37	60,872	10
11	1.40	10,752	2.51	64,256	11
12	1.50	11,520	2.64	67,584	12
13	1.58	12,134	2.76	70,656	13
14	1.66	12,749	2.87	73,472	14
15	1.75	13,340	2.97	76,032	15
16	1.81	13,901	3.07	78,592	16
17	1.90	14,592	3.17	81,152	17
18	1.97	15,130	3.26	83,456	18
19	2.00	15,360	3.34	85,504	19
20	2.05	15,744	3.42	87,552	20
21	2.12	16,281	3.50	89,660	21
22	2.18	16,742	3.57	91,392	22
23	2.21	16,973	3.63	92,928	23
24	2.30	17,664	3.70	94,720	24
25	2.34	17,971	3.76	96,256	25
26	2.37	18,202	3.81	97,536	26
27	2.40	18,432	3.85	98,560	27
28	2.41	18,509	3.89	99,584	28
29	2.43	18,662	3.93	100,608	29
30	2.45	18,816	3.97	101,632	30
31	2.50	19,200	4.02	102,912	31
32	2.51	19,277	4.05	103,680	32
33	2.52	19,354	4.08	104,448	33

*From tests by Mr. J. A. Jamieson, Montreal, Canada, at the Canadian Northern Elevator, Port Arthur, Ont., on a cribbed wooden bin, having inside dimensions, 13 ft. 4 ins. by 13 ft. 4 ins. by 65 ft. deep, and filled with wheat weighing 50 lbs. per cubic ft.

Each section of bin 1 foot high contains 7,680 square inches, so that column 3 is obtained by multiplying column 2 by 7680. In like manner column 5 is obtained from column 4 by multiplying by 25600, the area of the bin in square inches.

Ratio of Grain to Liquid Pressure.—Fig. 156, from "Kahn System Standards," p. 78, is derived from experiments and formulas by Mr. J. A. Jamieson, as presented in a paper before the

TABLE LXXIII, (Continued.)—GRAIN PRESSURE IN DEEP BINS.

Height in Feet.	Lateral Pressure in Lbs.		Vertical Pressure in Lbs.		Height in Feet.
	Per sq. in.	Total per ft. section.	Per sq. in.	Wt. on bottom.	
34	2.53	19,430	4.11	105,216	34
35	2.55	19,584	4.15	106,240	35
36	2.58	19,814	4.17	106,752	36
37	2.60	19,968	4.19	107,264	37
38	2.61	20,045	4.24	108,544	38
39	2.615	20,083	4.26	109,056	39
40	2.62	20,122	4.28	109,568	40
41	2.63	20,198	4.30	110,080	41
42	2.64	20,275	4.33	110,848	42
43	2.65	20,352	4.35	111,360	43
44	2.66	20,429	4.37	111,872	44
45	2.67	20,506	4.38	112,128	45
46	2.68	20,582	4.39	112,384	46
47	2.69	20,659	4.41	112,896	47
48	2.70	20,736	4.41	112,896	48
49	2.70	20,736	4.44	113,664	49
50	2.70	20,736	4.45	113,920	50
51	2.70	20,736	4.46	114,176	51
52	2.71	20,813	4.47	114,432	52
53	2.71	20,813	4.48	114,688	53
54	2.71	20,813	4.49	114,944	54
55	2.72	20,890	4.50	115,200	55
56	2.72	20,890	4.51	115,456	56
57	2.73	20,966	4.52	115,712	57
58	2.74	21,043	4.52	115,712	58
59	2.75	21,120	4.55	116,220	59
60	2.76	21,197	4.55	116,220	60
61	2.77	21,274	4.55	116,220	61
62	2.77	21,274	4.55	116,220	62
63	2.77	21,274	4.55	116,220	63
64	2.77	21,274	4.55	116,220	64
65	2.77	21,274	4.55	116,220	65

Canadian Soc. of C. E., December, 1903. The curve shows the ratio of observed grain pressure to a corresponding liquid pressure, supposing the bin to be filled to the same depth with a liquid of the same weight per cu. ft. as the grain. The values of K are shown for different values of

$$\frac{h}{b}$$

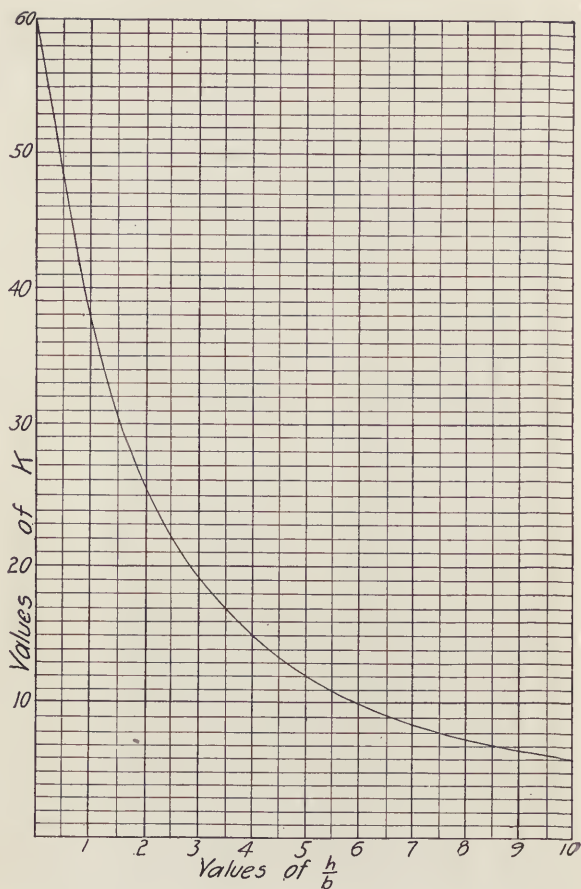

Fig. 156.—Graphic Diagram of Wheat Pressure in Bins.

which is the ratio of the depth of grain to the side of a square bin, or least side of a rectangular bin.

The tests mentioned show that the pressures were somewhat increased when grain was running out of the bin, and also that by tapping the side of a model bin an increased pressure of 20 per cent was obtained. Moisture also has considerable influence. For these reasons a factor of safety of 6 is recommended.

The following notation is used in constructing the diagram:

Angle of repose = 28° .

Coefficient of friction = 0.41667.

Lateral pressure = 0.6 vertical pressure.

h = height or depth of grain.

b = least side of bin.

K = ratio of actual grain pressure to liquid pressure.

w = weight of wheat = 50 lbs. per cu. ft.

Side pressure per sq. ft. = Kwh .

Bottom pressure at any depth = $1.667 Kwh$.

Maximum bottom pressure occurs when $\frac{h}{b} = 3.5$.

Maximum bottom pressure per sq. ft. = wb .

Example.—Let it be required to find the vertical and horizontal pressures at the bottom of a bin 10 ft. square and 40 ft. deep.

$$\frac{h}{b} = 4$$

From the curve,

$K = .149$.

Side pressure = $Kwh = .149 \times 50 \times 40 = 298$ lbs. per sq. ft.

Bottom pressure = $1.667 Kwh = 497$ lbs. per sq. ft.

Vertical load carried by side walls = $200,000 - (497 \times 100) = 150,300$ lbs.

Vertical Pressure.—The vertical pressure in a deep grain bin is calculated as follows: The grain supported by the side walls is equal to the lateral pressure multiplied by the coefficient of friction of the grain on the bin wall. The grain carried on the bottom of the bin is equal to the total weight of grain, minus the weight carried by the side walls. The bottom pressure is not uniformly distributed, but is a minimum at

the side walls and a maximum at the center. The grain mass producing bottom pressure may be represented by a portion of an ellipsoid of revolution with the major axis of the ellipse vertical.

Ratio Between Lateral and Vertical Pressure.—The value of the ratio between lateral and vertical pressure in a bin,

$$k = \frac{L}{V}$$

is not a constant for grain in a bin at different depths, being greater for small than for large depths of grain and varying with different bins and different grains. Average values of k for wheat and rye are given in Table LXXIV.

TABLE LXXIV.—VALUES OF $k = \frac{L}{V}$ IN DIFFERENT BINS.

Bins.	$k = \frac{L}{V}$	
	Wheat.	• Rye.
Cribbed bin.....	0.4 to 0.5	0.23 to 0.32
Ringed cribbed bin.....	0.4 to 0.5	0.3 to 0.34
Small plank bin.....	0.34 to 0.46	0.3 to 0.45
Large plank bin.....	0.3	0.23 to 0.28
Reinforced concrete bin.....	0.3 to 0.35	0.3

The Coefficient of Friction.—The coefficient of friction of grain on concrete is 0.4 to 0.425, according to roughness of the concrete.

The coefficient of friction of wheat on wheat is 0.532, or $\tan 28^\circ$. Table LXXV, coefficients of friction for various materials, is compiled by Mr. Wilfred Airy as a result of his experiments, printed in the proceedings of Inst. of Civ. Eng., Vol. CXXXI, 1897.

TABLE LXXV.—COEFFICIENTS OF FRICTION OF VARIOUS MATERIALS.

	Weight loose.	Coefficient of Friction.				
		Grain on grain.	Grain on rough wood.	Grain on smooth wood.	Grain on iron.	Grain on cement.
Wheat.....	49	.466	.412	.361	.414	.444
Barley.....	39	.507	.424	.325	.376	.452
Oats.....	28	.532	.450	.369	.412	.466
Corn.....	44	.521	.344	.308	.374	.423
Beans.....	46	.616	.435	.322	.366	.442
Peas.....	50	.472	.287	.268	.263	.296
Tares.....	49	.554	.424	.359	.364	.394
Flaxseed.....	41	.456	.407	.308	.339	.414

Pressure of Coal in Bins.—Tables LXXVI and LXXVII, giving the pressure of coal in bins, are taken from the paper by Mr. R. W. Dull, printed in Engineering News, July 21, 1904. See Fig. 157. In the formulas,

ϕ = angle of repose

ϕ' = angle of friction between material and bin wall

= angle between direction of thrust and normal to bin wall

P = total thrust against bin wall per ft.

N = horizontal component of P

δ = angle of slope of surface of material.

For both the tables,

Col. 1 gives normal component of total pressure on vertical side, when surface is level.

$$N = \left(\frac{\cos \phi}{n+1} \right)^2 \frac{wh^2}{2} \quad \text{where } n = \sqrt{\frac{\sin(\phi + \phi') \sin \phi}{\cos \phi}} \quad \dots (70)$$

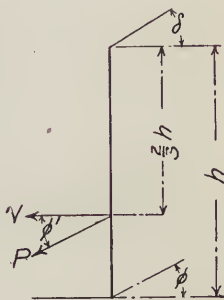

Fig. 157.

TABLE LXXVI.—TOTAL PRESSURE AT DEPTH h FOR BITUMINOUS COAL.Wt. per cu. ft. = 50 lbs. Angle of repose = $\phi = 35^\circ$.





Pressures for a section of material 1 ft. wide.

Depth in feet.	1	2	3	4	5	6
h	$\phi' = 18^\circ$	$\phi' = 0$	$\delta = \phi$	$\delta = \phi$	$\delta = \phi$	$\delta = \phi$
1	5.83	6.75	16.75	20.5	4.27	5.13
2	23.32	27.00	67.00	82.0	17.1	20.5
3	52.47	60.75	150.75	184.5	38.4	46.2
4	93.4	108.00	268.00	328	68.3	82.0
5	145.7	168.75	418.75	513	107	128.0
6	209.4	243	603	738	156	184.5
7	286	333	821	1,005	209	257
8	373	432	1,072	1,312	273	328
9	472	547	1,357	1,661	346	415
10	583	675	1,675	2,050	427	513
11	705	817	2,027	2,481	516	615
12	840	972	2,412	2,952	615	738
13	985	1,141	2,831	3,465	722	866
14	1,143	1,323	3,283	4,018	838	1,005
15	1,312	1,519	3,769	4,613	960	1,152
16	1,492	1,728	4,288	5,248	1,093	1,311
17	1,685	1,951	4,841	5,945	1,232	1,480
18	1,889	2,187	5,427	6,642	1,382	1,660
19	2,105	2,437	6,047	7,400	1,541	1,852
20	2,332	2,700	6,700	8,200	1,708	2,052
21	2,571	2,977	7,387	9,041	1,883	2,262
22	2,821	3,267	8,102	9,922	2,065	2,483
23	3,084	3,571	8,861	10,845	2,259	2,560
24	3,358	3,888	9,648	11,808	2,460	2,810
25	3,644	4,219	10,469	12,813	2,669	3,206
26	3,941	4,563	11,323	13,858	2,887	3,468
27	4,250	4,923	12,211	14,945	3,113	3,740
28	4,570	5,292	13,142	16,072	3,348	4,022
29	4,903	5,677	14,087	17,241	3,591	4,314
30	5,247	6,075	15,075	18,450	3,843	4,617

TABLE LXXVII.—TOTAL PRESSURE AT DEPTH h FOR ANTHRACITE COAL.

Wt. per cu. ft. = 52 lbs. Angle of repose = $\phi = 27^\circ$.

Pressures for a section of material 1 ft. wide.

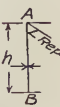
Depth in feet.	1	2	3	4	5	6
						
h	$\phi' = 16^\circ$	$\phi' = 0$	$\delta = \phi$	$\delta = \phi$	$\delta = \phi$	$\delta = \phi$
1	8.39	9.75	20.05	23.17	6.38
2	33.5	39.0	82.0	93.3	25.5
3	75.5	87.0	184.5	208.6	57.5
4	134.2	156	328	371	102.0
5	210	244	513	579	159.5
6	302	351	738	834	230
7	411	478	1,005	1,135	313
8	536	624	1,312	1,482	402
9	680	790	1,661	1,876	517
10	839	975	2,050	2,317	638
11	1,014	1,180	2,481	2,802	773	925
12	1,209 ^v	1,405	2,952	3,340	920	1,100
13	1,418	1,648	3,465	3,918	1,080	1,290
14	1,643	1,910	4,018	4,540	1,250	1,497
15	1,887	2,193	4,613	5,220	1,436	1,720
16	2,145	2,500	5,248	5,930	1,636	1,953
17	2,421	2,808	5,945	6,696	1,845	2,207
18	2,718	3,160	6,642	7,507	2,064	2,471
19	3,030	3,521	7,400	8,363	2,310	2,758
20	3,350	3,902	8,200	9,268	2,554	3,053
21	3,700	4,303	9,041	10,218	2,820	3,372
22	4,061	4,718	9,922	11,214	3,086	3,701
23	4,438	5,156	10,845	12,257	3,372	4,040
24	2,833	5,611	11,808	10,346	3,680	4,398
25	5,244	6,097	12,813	14,481	3,985	4,770
26	5,672	6,600	13,858	15,663	4,521	5,160
27	6,116	7,112	14,945	16,891	4,650	5,560
28	6,578	7,638	16,072	18,165	5,000	5,979
29	7,056	8,202	17,241	19,486	5,370	6,421
30	7,551	8,775	18,450	20,853	5,742	6,880

Col. 2 gives pressure against vertical plane *AB* when friction is not considered, *i. e.*, is taken as = 0.

$$N = \frac{wh^2}{2} \tan^2 \left(45 - \frac{\phi}{2} \right) \dots \dots \dots (71)$$

Col. 3 gives normal component of total pressure on vertical side when surface is surcharged to the angle of repose, and the bin is unlimited in horizontal extent.

$$N = \cos^2 \phi \frac{wh^2}{2} \dots \dots \dots (72)$$

Col. 4 gives the same as Col. 3, except that angle of friction is neglected.

$$N = \cos \phi \frac{wh^2}{2} \dots \dots \dots (73)$$

Col. 5 gives normal component of total pressure on vertical side when material slopes downward along angle of repose.

$$N = \left(\frac{\cos \phi}{n+1} \right)^2 \frac{wh^2}{2} \text{ where } n = \sqrt{\frac{\sin(\phi + \phi') \sin(\phi + \delta)}{\cos \phi' \cos \delta}} \dots (74)$$

Col. 6 gives same as Col. 5, except that friction is neglected.

$$N = \left(\frac{\cos \phi}{n+1} \right)^2 \frac{wh^2}{2} \text{ where } n = \sqrt{\frac{\sin \phi \sin(\phi + \delta)}{\cos \delta}} \dots \dots (75)$$

Weight, Angle of Repose and Angle of Friction of Various Materials.—Table LXXVIII gives the weight and angle of repose of coal, coke, ashes and ore as compiled from various authorities, and Table LXXIX, gives the angle of friction of coal, ashes, coke and sand on bin walls.

Capacity of Bins.—Tables LXXII, page 288, gives the capacity of tanks in gallons. These values may be changed to bushels by multiplying the number of cubic feet by 0.8, the result being the capacity in bushels.

TABLE LXXVIII.—WEIGHT AND ANGLE OF REPOSE OF COAL, COKE, ASHES AND ORE.

Material.	Wt. in lbs. per cu. ft.	Angle of repose in degrees.	Authority.
Bituminous coal.....	50	35	Link Belt Machinery Co.
“ “	47	35	Link Belt Engineering Co.
“ “	47 to 56	Cambria Steel Co.
Anthracite coal.....	52	27	Link Belt Machinery Co.
“ “	52.1	27	Link Belt Engineering Co.
“ “ fine.....	27	K. A. Muellenhoff.
“ “	52 to 56	Cambria Steel Co.
Slaked coal.....	45	Wellman-Seaver-Morgan Co.
“ “	53	37.5	Gilbert & Barth.
Coke.....	23 to 32	Cambria Steel Co.
Ashes.....	40	40	Link Belt Machinery Co.
Ashes, soft coal.....	40 to 45	Cambria Steel Co.
Ore, soft iron.....	35	Wellman-Seaver-Morgan Co.

TABLE LXXIX.—ANGLE OF FRICTION OF MATERIALS ON BIN WALLS.

Material.	Steel plate. ϕ' in degrees.	Wood cribbed ϕ' in degrees.	Concrete. ϕ' in degrees.
Bituminous Coal.....	18	35	35
Anthracite Coal.....	16	25	27
Ashes.....	31	40	40
Coke.....	25	40	40
Sand.....	18	30	30

Conclusions.—The following interesting conclusions are drawn by Professor Ketchum from experiments on grain pressure made by Messrs. Jamieson, Airy, Prante, Pleissner, Lufft, Bovey, Janssen and others:

(1) The pressure of grain on bin walls and bottom follows a law which for convenience will be called the law of semi-fluids, and which is entirely different from the law of the pressure of fluids.

(2) The lateral pressure of grain on bin walls is less than the vertical pressure (0.3 to 0.6 of the vertical pressure, depending on the grain, etc.), and increases very little after a depth of $2\frac{1}{2}$ to 3 times the width or diameter of the bin is reached.

(3) The ratio of lateral to vertical pressure, k , is not a constant, but varies with different grains and bins. Its value can be determined only by experiment.

(4) The pressure of moving grain is very slightly greater than the pressure of grain at rest (maximum variation for ordinary conditions being probably 10%).

(5) Discharge gates in bins should be located at or near the center of the bin.

(6) If the discharge gates are located in the sides of the bins, the lateral pressure due to moving grain is decreased near the discharge gate and is materially increased on the side opposite the gate. For common conditions this increased pressure may be 2 to 4 times the lateral pressure of grain at rest.

(7) Tie rods decrease the flow, but do not materially affect the pressure.

(8) The maximum lateral pressures occur immediately after filling, and are slightly greater in a bin filled rapidly than in a bin filled slowly. Maximum lateral pressures occur in deep bins during filling.

(9) The calculated pressures by either Janssen's or Airy's formulas agree very closely with actual pressures.

(10) The unit pressures determined on small surfaces agree very closely with unit pressures on large surfaces.

(11) Grain bins designed by the fluid theory are in many cases unsafe, as no provision is made for the side walls to carry the weight of the grain and the walls are crippled.

(12) Calculation of the strength of wooden bins that have been in successful operation shows that the fluid theory is untenable, while steel bins designed according to the fluid theory have failed by crippling the side plates.

Classification of Grain Elevators.—Grain elevators are divided into several classes. There are terminal elevators, transfer and cleaning elevators, storage houses, and station elevators. They are also divided into working houses and storage houses. The station elevators generally run from 5,000 to 100,000 bushels' capacity, and are combined working and storage houses. The working house contains all the elevating, weighing, cleaning, and shipping machinery. The storage elevator generally only contains receiving and shipping machinery, con-

sisting of belt conveyors. From the station elevators in the country, the grain is shipped by rail either directly to terminal elevators for export or to transfer and cleaning houses to be mixed, graded, cleaned, and transferred to other railroads. A transfer and cleaning elevator is generally termed a three-car house, four-car house, or a six-car house, according to the number of grain cars that can be unloaded simultaneously. The storage capacity of these houses is generally very limited, running from 75,000 to 250,000 bushels. The terminal elevator consists either of a combined storage or working house in one structure or a storage house and a working house for the receipt and discharge of grain. The capacity of a terminal elevator generally runs from 300,000 to 3,000,000 bushels or more.

Comparative Cost of Timber and Reinforced Concrete Elevators.—For many years wooden cribbing was used in square bins for the storage of grain and owing to their inflammable nature, a heavy insurance charge was necessary. While such storage elevators could be built from 8 to 15 cts. per bushel capacity in inverse proportion to the size, the charges for insurance and deterioration were quite heavy. Reinforced concrete storage houses which cost from 14 to 20 cts. per bushel capacity for large sizes and also in inverse proportion to their capacity need not carry any charges for insurance of the structure nor for deterioration, and have now become a favorite mode of construction. Working houses which cost from 20 to 30 cts. per bushel in wood cost practically twice as much in concrete. This is due to the fact that for storage houses circular bins can be used, which is by far the most economical shape for the storage of materials, while for work houses square bins are more practical, but of considerably higher expense.

Cement Storage Tanks, Illinois Steel Co., South Chicago, Ill.—The author has invented and patented a fire-proof "cluster-tank construction," the first application of which was made in the construction of cement storage tanks for the Illinois Steel Co. at South Chicago, Ill., in 1901. Fig. 158 shows sectional views, Fig. 159 the plan, and Fig. 160 details of the construction. The tanks are 25 ft. in diameter, 29 ft. center to

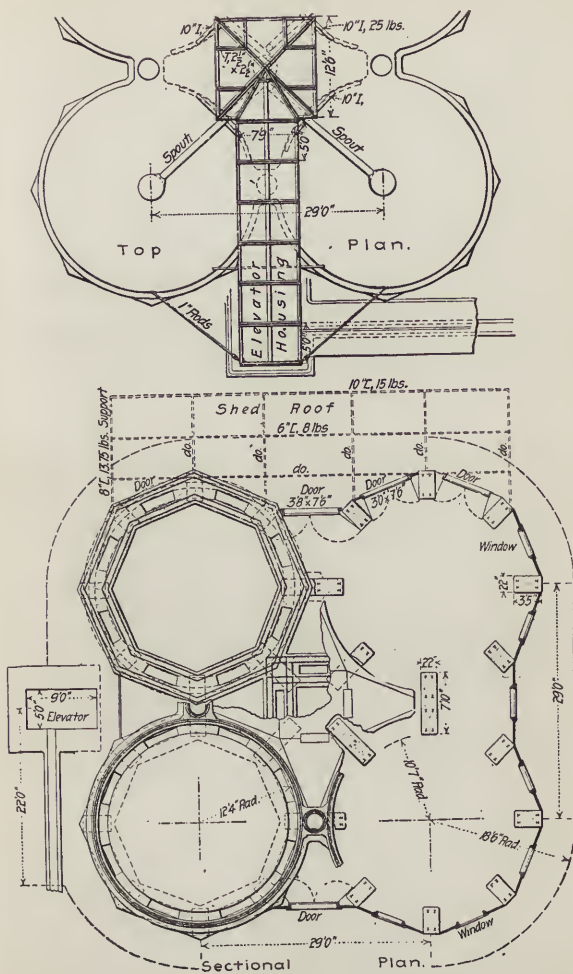

Fig. 159.—Plan of Cement Storage Bins, Illinois Steel Co., Chicago.

center, inclosing a center tank, which makes the cluster construction of five tanks, the space between each pair of adjacent walls being closed by a cylindrical shaft 30 ins. in diameter, the entire structure being monolithic. The foundation is on made ground and consists of a mat 66 ft. square, 3 ft. thick and reinforced by a netting of $\frac{5}{8}$ -in. steel rods of 9-in. mesh tied together at their intersections by No. 18 wire. Upon this con-

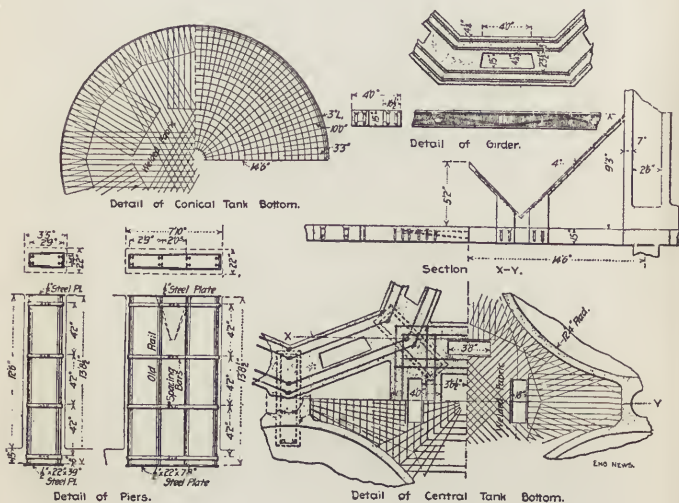

Fig. 160.—Details of Cement Storage Bins, Illinois Steel Co., Chicago.

crete bed is a series of piers 12 ft. 6 ins. high and 1 ft. 10 ins. thick. Those near the outer circumference of the tanks are 3 ft. 5 ins. long, but those supporting the corners of the tanks are 7 ft. 10 ins. long. The smaller piers have 4 steel rails, the larger 6 or 8 rails, embedded in the concrete. The rails are connected by splicing bars riveted to them, and rest on $1\frac{1}{2}$ -in. steel plates embedded in the concrete floor about 15 ins. below the surface. The piers are capped with similar plates and sup-

port concrete steel girders 10 ins. deep and 4 ft. wide with vertical openings at intervals for the discharge pipes. Through each girder run four horizontal lines of steel rods near the top, and four other lines bent to form truss rods with sheets of wire netting on each side of each pair of rods. The cylindrical tanks 53 ft. 6 ins. high rest upon this system of girders, the base being 13 ft. 9 ins. above the level of the concrete floor. The walls are 7 ins. thick in the lower part and 5 ins. in the upper part. The reinforcement consists of a continuous sheet of netting of No. 9 Clinton wire cloth 1x4-in. mesh. Around this alternately inside and outside are horizontal rings of rods 4 ins. apart tied to the netting by wire. These rods vary in diameter from 1 in. near the base to $\frac{3}{8}$ in. near the top, which is finished with a ring formed by a 5-in. Z bar supporting the conical roof. The latter is 2 ins. thick with a manhole at the edge, and an opening at the apex for the spout. In place of hopping the bin bottoms in an inverted cone as usual, these hoppers were reversed, the apex pointing upwards so as to prevent any trouble in the discharge of the cement by bridging. The discharge openings around the circumference are 15x48 ins. and each serves a sacking spout. The conical bottom is 4 ins. thick, reinforced with rods and netting. The foundation concrete and also the pier concrete consist of 1 part Portland cement, 3 parts coarse sand, and 4 parts of crushed limestone. The tanks proper are built of mortar of 1 part Portland cement and $3\frac{1}{2}$ parts sand, mixed, weighed and lightly rammed in wooden forms. The concrete was poured in and tamped inside of the forms, which were raised in 45° sections 28 ins. high, every 24 hours. Work was carried on day and night until finished. The elevator shaft is built of steel frame covered with Monier siding plates, 2x5 ft. by $\frac{5}{8}$ in. thick, made of cement mortar and wire netting similarly as for roofs.

Canadian Pacific Grain Elevator, Port Arthur, Ont.—Fig. 161 shows a plan of the Canadian Pacific grain elevator at Port Arthur, Ont., built by Barnett & Record Co. in 1904 on the cluster tank principle. There are nine cylindrical tanks so as to inclose four intermediate spaces, the entire construction being

monolithic. The circular bins are 30 ft. in diameter and 90 ft. high, and as no necessity existed for making the intermediate spaces larger, the tanks were placed close together and the strength of the tank connections was further increased by placing brace rods in the intermediate bins. The walls are 9 ins.

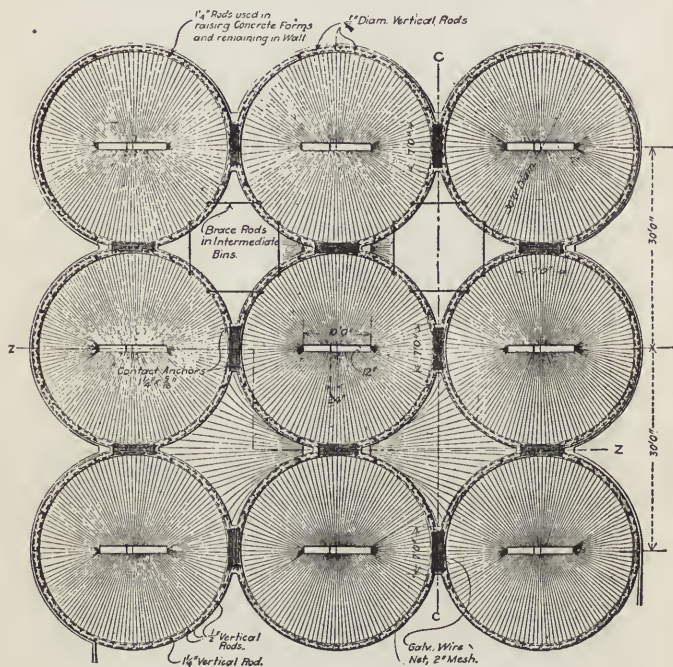

Fig. 161.—Plan of Canadian Pacific Grain Elevator, Port Arthur, Ontario.

thick on foundations 24 ins. thick carried down to footings resting on hard pan. The conical tank bottoms are seated on rammed sand fill. Under the center of each row of bins there is a concrete lined conveyor tunnel 7 ft. wide, 7 ft. high and about 86 ft. long. The concrete used was 1 part Portland cem-

ent, 3 parts sand, and 5 parts Lake Superior gravel. The horizontal reinforcement consists of hooping bars spaced 12 ins. apart vertically, the size of the bars decreasing from the bottom upwards. The bars are in pairs, one near each surface of the shell. For the first 15 ft. above the base their cross-section is 1 sq. in., for the next 35 ft. it is .88 sq. in., for the next 20 ft. .75

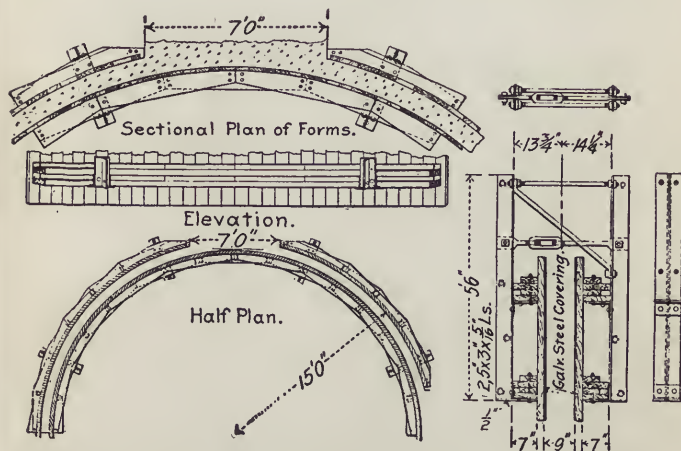

Fig. 162.—Forms for Bin Construction, Grain Elevator, Port Arthur, Ontario.

sq. in., and above that a cross-section of $\frac{1}{2}$ sq. in. Besides the horizontal bars there are in each bin 27 vertical bars, spaced equally distant apart. Where adjacent tanks touch and have the walls thickened accordingly, the two hoops are clamped together by 2 straps $1\frac{1}{4} \times \frac{5}{16}$ ins. every foot in height, whose ends hook over the two hoops. There is also in this thickened portion a horizontal sheet of wire netting at every foot in height. The concrete walls of the bins were made in cylindrical forms, 4 ft. high, as shown in Fig. 162. The curved surfaces of the forms were made of 2-in. vertical planks spiked to the inside and outside circular chords, which latter were made like arch centers with four thicknesses of 2x8-in. scarfed planks

bolted together to break joints and to make complete circles inside the tanks and circular segments on outside of tanks. The molds were faced on the inside with No. 28 galvanized steel, and were maintained in concentric positions with a fixed distance between them by means of 8 U-shaped steel yokes in radial planes, as plainly shown in the illustration. The lower ends of the vertical yoke posts were seated on jack-screws and were supported on false work built up inside the tanks, as the walls progressed.

CHAPTER VII.

CHIMNEYS, MISCELLANEOUS DATA, COST KEEPING, ESTIMATING, SPECIFICATIONS, ETC.

CHIMNEYS.

Calculation.—Chimneys are designed to withstand the stresses from their own weight and in addition a wind pressure generally taken at 50 lbs. per sq. ft., and for circular chimneys this pressure is applied to one-half the projected area.

In Germany and Austria two-thirds the projected area is figured, but only a wind pressure of 35 lbs. per square foot. In chimneys with an inner and an outer shell only the outer shell is taken into consideration. The foundation is usually so arranged that the dead load of the chimney does not exceed 1 ton per sq. ft. on the soil and the combined wind and dead load does not exceed 2 tons per sq. ft.

In calculating the dimensions of the shell, the weight is first taken into consideration and the load divided on the concrete and the steel, in proportion to the ratio of the two moduli of elasticity.

The wind pressure will act at one-half the height and will produce a moment M about the center of the horizontal section to be examined. The pressure in the extreme fiber C in the concrete will be expressed by the equation

$$C = \pm \frac{MD}{2(I_c + nI_s)} \dots\dots\dots (76)$$

where D = external diameter of the chimney

I_c = moment of inertia of the concrete section

I_s = moment of inertia of the reinforcement

$$n = \frac{E_s}{E_c}$$

The stresses in the reinforcement due to wind pressure will be

$$f = \frac{nMd_s}{2(I_c + nI_s)} \dots\dots\dots (77)$$

Where d_s is the diameter of circle in which the steel reinforcement is located.

This calculation may also be used for tanks or towers to take care of wind pressure.

The Core Theory.—As some engineers introduce the core theory in chimney calculations, we will briefly refer to this feature.

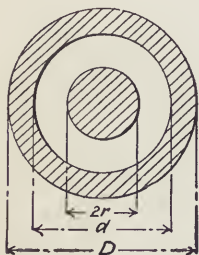

Fig. 163.— Cross-Section Showing Neutral Core in Chimney.

The core of a cross section is the area inside of which a force must be applied when the entire cross section is to have stresses of the same sign (+ or -). If the force is applied outside the core, the cross section will have both tension and compression.

If the force is applied in the circumference of the core, the stresses will go as far as to zero, but all will have the same sign.

Hence the core circumference really represents the line in which all zero

points are located.

The core radius, r is the section modulus W divided by the area F (See Fig. 163).

Now
$$W = \frac{\pi}{32} \frac{D^4 - d^4}{D}$$

and
$$F = \frac{\pi}{4} (D^2 - d^2)$$

hence
$$r = \frac{W}{F} = \frac{D}{8} \left[1 + \left(\frac{d}{D} \right)^2 \right] \dots\dots\dots (78)$$

for a homogeneous section.

It is not within the province of this book to enter into the more intricate methods of calculations, such as described by Dr. R. Salinger in *Beton u. Eisen*, 1905, pages 253 and 273, as the

method herein given is safe enough both for original calculations and review.

Wind Pressure and Velocity.—From experiments made by Prof. C. F. Marvin of U. S. Weather Bureau (see Anemometry, Circular D, second edition, 1900) it is found that wind pressures are not so great as generally computed and are quite accurately given by the following equation:

$$P = 0.004 \frac{B}{30} (SV^2) \dots\dots\dots (79)$$

Where P = pressure in pounds.

S = surface in sq. ft.

V = corrected velocity of wind in miles per hour.

B = height of barometer in inches.

For stations near the sea level, where the barometric pressure does not vary much from 30 ins., the ratio $\frac{B}{30}$ need not be considered. The relation between the wind velocity V in miles per hour and the linear velocity v of the cup centers of an anemometer, also in miles per hour, can be expressed by the following equation:

$$\log V = 0.509 + 0.9012 \log v \dots\dots\dots (80)$$

and Table LXXX gives true velocities as compared with indicated velocities, and corresponding wind pressures.

Approximate Method of Calculation.—A simple and safe approximate method for calculating chimneys is given in Beton und Eisen, 1905, Heft X, and is as follows:

F = the cross section of the outer shell in sq. ins.

r = the mean radius of cross section in ft.

A_s = cross section of vertical bars in sq. ins.

$$m = \frac{1000 A_s}{F}$$

R = the lever arm from the center of the chimney to the resultant of the weight in tons of the chimney Q and the wind pressure W .

TABLE LXXX.—WIND VELOCITIES AND PRESSURES AS INDICATED BY ROBINSON'S ANEMOMETER.
(Corrected to true velocities.)

Indicated velocity.	True Velocity.									
	+0	+1	+2	+3	+4	+5	+6	+7	+8	+9
0	5.	6.	6.9	7.8	8.7
10	9.6	10.4	11.3	12.1	12.9	13.8	14.6	15.4	16.2	17.0
20	17.8	18.6	19.4	20.2	21.0	21.8	22.6	23.4	24.2	24.9
30	25.7	26.5	27.3	28.0	28.8	29.6	30.3	31.1	31.8	32.6
40	33.3	34.1	34.8	35.6	36.3	37.1	37.8	38.5	39.3	40.
50	40.8	41.5	42.2	43.0	43.7	44.4	45.1	45.9	46.6	47.3
60	48.0	48.7	49.4	50.2	50.9	51.6	52.3	53.0	53.8	54.5
70	55.2	55.9	56.6	57.3	58.0	58.7	59.4	60.1	60.8	61.5
80	62.2	62.9	63.6	64.3	65.0	65.7	66.4	67.1	67.8	68.5
90	69.2

Pressure (Lbs. per sq. ft.)

0104	.144	.190	.243	.303
10	.369	.433	.511	.586	.666	.762	.853	.949	1.05	1.16
20	1.27	1.38	1.50	1.63	1.76	1.90	2.04	2.19	2.34	2.48
30	2.64	2.81	2.98	3.14	3.32	3.50	3.67	3.87	4.04	4.24
40	4.44	4.64	4.84	5.07	5.27	5.51	5.72	5.93	6.18	6.40
50	6.66	6.89	7.12	7.4	7.64	7.88	8.14	8.43	8.69	8.95
60	9.22	9.49	9.76	10.1	10.4	10.6	10.9	11.2	11.6	11.9
70	12.2	12.5	12.8	13.1	13.5	13.8	14.1	14.4	14.8	15.1
80	15.5	15.8	16.2	16.5	16.9	17.3	17.6	18.0	18.4	18.8
90	19.2

C = maximum stress in concrete in lbs. per sq. in.

f = maximum compression in steel in lbs. per sq. in.

f_1 = maximum tension in steel in lbs. per sq. in.

M = moment of wind pressure in foot tons.

Then we have

$$R = \frac{M}{Q}$$

and

$$C = \frac{Q}{AF} \dots \dots \dots (81)$$

$$f = nC = \frac{E_s}{E_c} C = 15C \dots \dots \dots (82)$$

$$f_1 = BC \dots \dots \dots (83)$$

where A and B are constants taken from the Tables LXXXI and LXXXII.

Example.—The external diameter of a chimney is 14.5 ft., its height 225 ft., and the thickness of the shell assumed to be 6 ins. Effective wind pressure is 20 lbs. per sq. ft.

Q = weight of shaft, approximately 360 tons

F = cross section of shell, approximately 3150 square inches

TABLE LXXXI.—VALUES FOR A IN FORMULA (81).

R $r.$	A									
	$M=0$	2.5	5	10	15	20	25	30	35	40
0.5	0.500	0.519	0.538	0.575	0.613	0.650	0.688
0.6	444	461	480	515	550	584	618
0.7	380	400	421	455	489	521	553
0.8	306	342	365	402	437	470	500	0.530
0.9	220	291	319	360	394	425	455	485
1.0	253	283	325	358	388	418	446
1.1	223	254	297	328	357	385	413	0.438
1.2	199	230	273	303	331	358	384	407
1.3	180	211	253	282	309	334	358	381
1.4	163	195	235	264	290	313	336	358	0.380
1.5	150	181	219	247	272	295	317	338	358
1.6	138	170	206	233	257	279	300	320	340
1.8	151	184	209	231	251	270	289	307
2.0	137	166	189	210	229	246	263	279
2.2	151	173	193	210	225	241	256
2.4	160	178	195	209	223	236
2.6	149	166	181	195	208	220

TABLE LXXXII.—VALUES FOR B IN FORMULA (83).

R $r.$	B									
	$M=0$	2.5	5	10	15	20	25	30	35	40
0.5	0	0	0	0	0	0	0	0	0	0
0.6	2.5	2.4	2.4	2.3	2.2	2.1	2.0
0.7	7.1	6.2	5.7	5.1	4.6	4.2	4.0
0.8	17.	12.	10.	8.5	7.3	6.7	6.3	5.9
0.9	44.	19.	14.8	11.5	9.9	8.9	8.2	7.7
1.0	26.	19.6	14.5	12.2	10.9	10.	9.3
1.1	32.	23.8	17.1	14.3	12.7	11.6	10.7	10.1
1.2	39.5	27.5	19.5	16.1	14.2	13.	12.	11.2
1.3	45.	30.9	21.6	17.8	15.6	14.2	13.1	12.3
1.4	50.	33.8	23.4	19.3	16.9	15.3	14.1	13.3	12.6
1.5	54.	36.5	25.	20.6	18.	16.3	15.	14.2	13.4
1.6	57.	39.	26.6	21.8	19.	17.2	15.8	14.9	14.1
1.8	43.2	29.3	23.7	20.7	18.7	17.2	16.2	15.4
2.0	47.	31.8	25.4	22.1	20.	18.4	17.3	16.5
2.2	34.	26.9	23.3	21.1	19.3	18.2	17.4
2.4	28.2	24.4	22.1	20.2	19.1	18.2
2.6	29.3	25.3	23.	21.1	19.8	18.9

W = wind pressure, assumed to average $14.5 \times 200 \times 20 = 29$ tons

$M = 29 \times 100$ ft. = 2900 foot tons

$A_s = \frac{3}{4}$ -in. rods 6 ins. on centers = $2\pi 14 \times 0.4418 = 39$ sq. ins.

$$m = \frac{1000 A_s}{F} = \frac{1000 \times 39}{3150} = 12.38$$

$$R = \frac{M}{Q} = \frac{2900}{360} = 8.06$$

$$r = \frac{1}{2}(14.05 - .05) = 7$$
 ft.

$$\frac{R}{r} = \frac{8.06}{7} = 1.15$$

Then we have, according to Tables LXXXI and LXXXII, by interpolation,

$$A = 0.301$$

$$B = 15.6$$

hence $C = \frac{Q}{AF} = \frac{720000}{.301 \times 3150} = 760$ lbs. per sq. inch

$$f = 15 \times C = 11400$$
 lbs. per sq. in.

$$f' = BC = 15.6 \times 760 = 11,856$$
 lbs. per sq. in.

Summary of Points in Design of Chimneys.—Mr. Sanford E. Thompson sets forth the following summary of essentials in design and construction of a reinforced concrete chimney:*

(1) Design the foundations according to the best engineering practice.

(2) Compute the dimensions and reinforcement in the chimney with conservative units of stress, providing a factor of safety in the concrete of not less than 4 or 5.

(3) Provide enough vertical steel to take all of the pull without exceeding 14,000 or, at most, 16,000 lbs. per sq. in.

(4) Provide enough horizontal or circular steel to take the vertical shear and to resist the tendency to expansion due to interior heat.

(5) Distribute the horizontal steel by numerous small rods in preference to larger rods spaced further apart.

(6) Specially reinforce sections where the thickness in the wall of the chimney is changed or which are liable to marked changes of temperature.

*Bulletin American Portland Cement Manufacturers' Association.

- (7) Select first class materials and thoroughly test them before and during the progress of the work.
- (8) Mix the concrete thoroughly and provide enough water to produce a quaking concrete.
- (9) Bond the layers of concrete together.
- (10) Accurately place the steel.
- (11) Place the concrete around the steel carefully, ramming it so thoroughly that it will slush against the steel and adhere at every point.
- (12) Keep the form rigid.

The fulfillment of these requirements will increase the cost of the chimney, but if the recommendations are followed there should be no difficulty in erecting concrete chimneys, which will give thorough satisfaction and last forever.

Construction.—During the past few years reinforced concrete chimneys have been built in great numbers, both on account of their strength and their cheapness.

The construction is generally carried on continuously from the base to the top, and the materials consist of cement and coarse sand proportioned one cement to four sand.

The Weber Steel Concrete Chimney.—The Weber Steel Concrete Chimney Co. of Chicago have designed and patented a type of chimney which probably represents the most advanced construction. Being air tight with a smooth inner shell, their chimney gives a high working capacity, and being much lighter than a brick stack, requires less of a foundation, usually only consisting of a plate connected to the shaft by means of a series of radial brackets. The overturning moment is resisted by the weight of the earth fill resting upon the foundation plate.

Fig. 164 shows a chimney built for the United Shoe Machinery Co. at Beverly, Mass., and gives the characteristic features of a Weber chimney. It is 6 ft. in diameter and 142 ft. 1 in. in height from the bottom of the foundation to the top. The foundation extends about 16 ft. below ground. The shell is double to the height of 48 ft. above ground, the

REINFORCED CONCRETE.

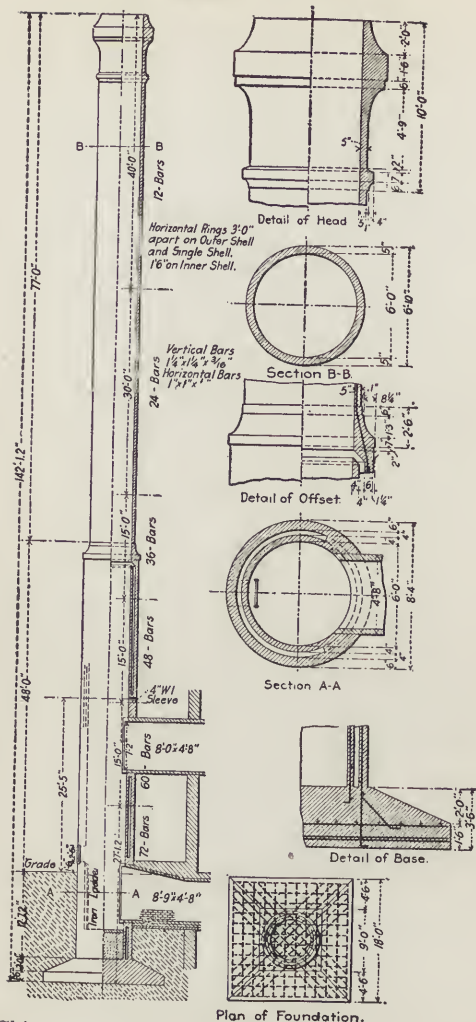

Fig. 164.—Chimney for United Shoe Machinery Co., Beverly, Mass.

inner shell being 4 ins. thick and the outer 6 ins. The upper single shell portion is 5 ins. thick. The reinforcement consists of $1\frac{1}{4} \times 1\frac{1}{4} \times 3/16$ in. vertical and $1 \times 1 \times \frac{1}{8}$ in. horizontal T irons. The number of bars in the circumference and the arrangement of rods in the foundation are given in the cut.

Construction of Molds.—The molds in the construction of Weber chimneys consist of two rings of six' sections, each about 3 ft. wide and connected by iron fastenings. They are held in place by friction on the concrete only and are disconnected before being hauled up to the required position. A flat ring is located above the forms to hold the vertical steel bars in position and alignment by running them through holes in the plate. This ring is made of two $\frac{3}{4}$ -in. layers of wood and is pushed on ahead of the forms, also carrying the beam for the hoisting pulley. All materials are hoisted inside the chimney. No interior scaffold is needed for the double shell and usually one form a day is filled and moved up.

For the single shell, two forms a day are filled. The vertical bars lap 24 ins. where spliced. Formerly a very dry mix was used and carefully tamped, but recently several mishaps have occurred, largely attributed to lack of water in the mortar, so at present a wetter mixture is being used. The rings are fastened to the vertical bars by means of wire or special clamps. The air space at the bottom is connected with the atmosphere and at the top of the inner shell with the flue proper. Care must be taken to keep the openings at the bottom clean from waste concrete in order to allow free circulation of air around the inner shell.

The Wiederholt Concrete Steel Chimney.—The Wiederholt chimney is built without forms by the means of thin H-shaped tiles placed edge to edge so as to contain the concrete and the reinforcement.

MANUFACTURED ARTICLES.

Among the manufactured articles of reinforced concrete should be named railroad ties, fence posts, telegraph poles,

electric transmission poles, smoke jacks, tubs and tanks of every description, coffins, roofing and siding plates, electric conduits, floor slabs, floor beams, pile protection, stair steps, balusters, building blocks, garden benches, manhole covers, chimney tops, door and window frames, sills, lintels and cornices. Each of these items introduces a new field in the industrial world of manufacture, the development of which largely belongs to the future and to the ingenuity of the concrete student.

INSPECTION.

In no other kind of building construction is there so much need for inspection as in reinforced concrete. Inspection of the cement in its manufacture, after delivery, and on the job; inspection of the sand as to its cleanness and condition; inspection of the stone as to its strength and size; inspection of the mixture of the three materials mentioned, and inspection of the amount of water added to make the proper consistency constitute only a small part of what is required of an inspector on an important reinforced concrete construction. There is the inspection of the steel in the reinforcement, the method of making and shaping and of assembling and connecting the reinforcement, and, finally, of placing and fastening it. There is the inspection of the forms, the quality of the timber, the method of putting it together to meet the intention of the designing engineer, and with a view to its easy removal so as to be used again. The filling of forms, the spading and tamping of the concrete around the reinforcement and against the forms and the joining of new work to old must be watched. An eye must be kept on the forms ahead of the concreting to see that they are cleaned free of shavings and dirt. While this is going on the inspector must watch the action of the forms and the setting of the cambers, look out for leaks, and at the same time keep an eye on the contractor's men to see that they do not run wheel barrows or carry heavy loads over the finished work.

During the hardening, the concrete surface must be kept moist. This item is often overlooked in rush work.

After the concrete is finally placed, with good materials and mixing and good workmanship, the inspector must see that the forms remain undisturbed until the concrete is hardened sufficiently to enable the removal of the struts and braces keeping them in position. Too early removal of forms has been the cause of most of the deplorable accidents which have tended to retard the advancement of reinforced concrete in the United States, and which has caused investors to look askance at this construction, otherwise so desirable from an engineering and economical standpoint. It is far better to be a few days behind time than to take chances on a too early removal of the forms. It is also the inspector's duty to see that the naked concrete is protected, in summer from the sun by wet saw dust or wet blankets and in the winter from freezing.

The cleaning of the molds is an important item and should be well looked after by the inspector. If the inspector is employed by the contractor, he should also be entrusted with the keeping of costs, a matter which will be treated later.

PROGRESS REPORTING AND KEEPING OF COSTS.

To enable the engineer or contractor to estimate work in a rational manner it is absolutely necessary for him to note down the detail cost of the practical execution of the work. This will also enable the contractor to analyze his expenditures with the view to improving his foremanship, laborers, plant equipment, and the like. By comparing his cost reports with the different items of his estimate he may be able either to find leaks in his methods or mistakes in his estimating. The cost of keeping progress and cost reports is always justified by the results. Several of the best construction companies in America, through a careful system of progress and cost reporting, have materially improved their

working methods and their knowledge of the work itself, besides securing data of value for use in future estimates.

When the manager, superintendent, foreman and men know that their work is closely watched and that not only are successive days' performances compared but that comparison is made with similar work previously executed and the result shown to the credit or discredit of the persons in charge of the work, they are spurred to do their best. In addition padded pay rolls are practically done away with, and thefts of tools and materials are reduced to a minimum. Machines are all kept in better order, as a falling off in output is quickly discovered, and it is a fact that the contractor who has a reputation of having a good system of watching the cost of his work is more apt to be trusted with percentage work or actual cost plus a fixed sum for his supervision and the use of his plant. To the engineer in charge of the work such reporting is of incalculable value, and he will soon find in Gillette's words that "it is fatal to good engineering to copy a specification without weighing the dollars and cents effect of every word and phrase. He will see that there is more than strains and stresses in the design of a bridge and more than coefficients of friction in conduits and canals." The labor items in reinforced concrete of which costs are to be recorded generally are as follows:

- (1) Stone crushing.
- (2) Concrete mixing and spreading.
- (3) Making and placing reinforcement.
- (4) Making and placing forms, including removal of same.
- (5) Finishing.

For each of these items the author prefers to use a card to be filled out daily in duplicate by using a carbon sheet, the original being sent to the office to be entered on the weekly report by a person kept in the office for this particular purpose, and the copy to remain at the job. The weekly report should be made in a form comparable with the estimate form and in such a shape that at any time the total cost of labor

to date can be added up for each item. The daily report cards should be numbered and dated and show remarks referring to such materials or other items as will be directly needed to prevent any stoppage or delay of the work so that the office is constantly kept informed as to proper delivery of material. A copy of all contracts with all conditions for delivery of tools or materials should be on hand at the construction office on the job so the superintendent may know exactly how to act without being compelled to await instructions from the office in case he sees he will run short of material. All orders issued from the office or from the job should be in triplicate, one for the party furnishing materials, one for the office or the job as the case may be, and one for file. It will be found convenient to make these report cards suitable for an index card file, hence of fairly stiff paper, the ones sent to the office being perforated and torn out of the book and those on the job to remain in the book. Sample cards as used by the author are shown herewith.

BLASTING.

Contract No. New York.....190..

No. of Blasts.....	Foreman.....	Derrickmen.....
No. of hours.....	Engineers.....	Laborers.....
Remarks.....	Firemen.....	Coal.....
.....	Rockmen.....	Repairs.....
.....	Drillers.....	Sundries.....
.....	Total.....

	Pay rolls.	Hauled to crushers	Hauled to dump.	Used in walls.	Blasted cu. yds.	Feet drilled.	Average cost cu. yd.	Cost hauling.
Previous..
To-day
Total...

Clerk..... Supt.....

REINFORCED CONCRETE.

REINFORCED CONCRETE
FORMS.

Contract No. New York, 190 ..

Where working.....	Foreman.....
.....	Carpenters.....
Remarks.....	Laborers.....
.....	Lathers.....
.....	Sundries.....

	Sq. ft. slabs.	Lin. ft. beams.	Lin. ft. col's.	Pay roll.	Feet B. M.	Old stuff.	New material.
Previous.....							
To-day.....							
Total.....							

Clerk Supt.

CRUSHING.

Contract No. New York, 190 ..

Teams to "A" Street, \$.....	Foreman.....
Teams to "B" Street, \$.....	Engineers.....
Remarks.....	Laborers.....
.....	Electric power.....
.....	Repairs.....
.....	Lumber.....

	Delivered to "A" St.	Delivered to "B" St.	Stored at crushers.	Hauling.		Pay roll crushing.
				Pay roll "A" St.	Pay roll "B" St.	
Previous.....						
To-day.....						
On hand.....						
Total.....						

Clerk Supt.

MASONRY.

Contract No. New York, 190..

Where working.....	Foreman.....
.....	Masons.....
Remarks.....	Laborers.....
.....	Sundries.....

	Pay rolls.	Bbbs. cement.	Bbbs. lime.	Yards sand.	Yards rock.	Yards Masonry.	Average cost per yard.
Previous.....							
To-day.....							
Total.....							

Clerk Supt.

SAND.

Contract No. New York, 190..

Remarks.	Wagon loads received from	Cubic yards received.	Cubic yards used masonry.	Cubic yards used brickwork.	Cubic yards used concrete.	Cubic yards used reinforced concrete.
.....						
.....						
.....						
Previous.....						
Today.....						
On hand.....						
Total.....						

Clerk Supt.

CEMENT.

Contract No.

New York, 190..

Remarks.	Received.		Bags.		Used in masonry.	Ccm. concrete.	Reinforced con- crete.	In mixers.	Brickwork.	Sundries.
	Car numbers.	No. bbls.	Received.	Returned.						
.....										
.....										
.....										
Previous.....										
To-day.....										
On hand.....										
Total.....										

Clerk.....

Supt.....

NOTES ON ESTIMATING.*

In estimating unit prices, too much reliance should not be placed on the published prices for similar work. Conditions vary greatly in places but a short distance apart; thus wages may be different, engineers may have entirely different interpretations of identical specifications, and bidding prices as published may be perfectly unbalanced, being too high on certain items with a view of getting the money out of the job at once, and too low on others. It must be remembered that a unit price that is fair for a large job is generally too low for a small job, and furthermore a contractor already equipped with a plant can often afford to bid lower than contractors who may be compelled to buy a new plant. For this reason each item should be estimated in detail and as a rule may be considered under the following heads:

*Summarized from Gillette's "Handbook of Cost Data."

- (1) Plant expenses and supplies.
- (2) Materials.
- (3) Labor.
- (4) Superintendence and general expense.

The plant expense includes interest and depreciation on all tools, machines, buildings, store materials, trestles, false work, and also cost of maintaining the plant during its operation, new parts, fuel, oil, etc. Materials include only such materials as actually go into the finished structure and the waste of materials due to breakage in handling or sawing and shaping. The cost of materials also includes the freight and the hauling to the site of the work. Labor includes all skilled and common labor including foreman and time keeper, but excluding superintendent and office expense.

Superintendence and general expense include all general office expenses which are to be divided on all jobs, such as rents, taxes, telephones, traveling and entertaining expenses, stationery, etc.

Plant Expense.—In estimating the cost of a plant it must be based upon a time limit at least 20 per cent less than the one mentioned in the contract, in addition to liberal allowances for bad weather, delivery delays and break downs. Use with great caution the figures of output given in catalogs; they are almost invariably based upon ideal conditions and frequently wholly deceptive.

For example, while a derrick may be able to handle 200 cu. yds. a day, in a confined space its actual output may not exceed 30 cu. yds. Do not guess at anything; if you have no other data secure some estimates of output of a similar plant from large and old manufacturing firms and compare their statements. Having liberally estimated the size and kind of plant required, charge the full cost of the plant up to the job to be done and determine how many cents per

yard or other units involved, are thus chargeable to the first cost of plant. This will give a maximum charge, and it is well to know the worst; but if the full cost of a plant is charged to a small job some other contractor will probably get the work. Go therefore to a dealer in second-hand machinery and ask him to name a fair price on a second-hand plant such as yours will be, when you are through with it.

If you can secure a tentative bid on the machinery, you will have a fairly reliable estimate of its salvage value. A plant can also be rented at so much a day or a month, and for short jobs this is usually the best policy, inasmuch as it never pays a contractor to be encumbered with much machinery, etc. Depreciation of a plant should include all the cost of housing and caring for the same, and be distributed over the average number of days that the plant is actually worked.

Current repairs cannot always be separated from depreciation and it is well to consider the replacing of all parts that wear out rapidly as being current repairs. Of course depreciation is a variable item; thus a cable-way, for example, may last two years if it handles only 25,000 skip-loads per year, but if 100,000 loads are handled in a year two cables will be worn out.

In figuring cost of fuel for engines, it is customary to allow one-third of a ton of coal for each 10 H. P. per 10-hour shift.

General expenses on contracts of \$100,000 or more run about $3\frac{1}{2}$ per cent, and under \$100,000 from 4 per cent up. The author has for many years used 3 per cent and found that it averaged just about right.

Percentage to Allow for Profits.—This is a question which has been much discussed. The percentage should depend upon the ratio between materials and labor employed and the duration of the contract, as well as its size. A percentage

of 10 for material and 20 to 25 on labor, where the material is furnished by some one else, is fair and customary. In addition to the percentage for profit there should be added a small percentage, say 2 or 3 per cent, for contingencies.

Accident Insurance.—The following is taken from a lecture to the students of engineering of Columbia University by Mr. Gillette:

“Never omit an allowance for accidents and other unforeseen contingencies. Second, never neglect to insure the workmen.

“A blanket policy covering all the men can be taken out. The premium is a given percentage of the pay roll. This insurance does not give to each man a weekly stipend in case of accident or to his heirs a designated sum in case of death. But what the insurance company does do is to protect a contractor by assuming all liabilities from claims made by insured workmen or their heirs. The insurance company limits this liability, however, so that in case a number of men are killed by one accident the contractor may have to stand part of the damages. No matter how safe the work seems to be, a contractor should never neglect to take out a pay roll insurance policy. Many a contractor just starting in business has been ruined through failure to insure against accident.”

In making estimates of any structure the first step should be to make a list of all the items which possibly may come into consideration, and the engineer or contractor should look over this list for every estimate he makes and check off such items as they have been covered. Such list of items should also be prepared and completed from the specifications, every item in the specification being represented on the estimating sheet. A sample estimate is here added for the guidance of an engineer or contractor on similar work.

BLANK FORM FOR ESTIMATE OF BUILDING.

Excavation.

Wrecking.
Blasting.
Sheeting.
Excavating.

Piling.

White oak piling.
Mixed piling.
Snubbing piles.
Concrete piles.

Caissons.

Lumber.
Rings.
Excavating.

Dampproofing.**Masonry.**

Plain concrete.
Dimension stone.
Rubble work.

Granite.

Carving.
Lewising.
Cartage.
Setting.

Cut Stone.

Exterior marble.
Carving.
Lewising.
Cartage.
Setting.

Blue Stone.

Sills and lintels.
Copings.
Walks.
Curbs.
Cartage.
Setting.

Terra Cotta.

Cartage.
Setting.

Brickwork.

Common brick.
Pressed brick.
Glazed brick.
Hollow brick.

Plastering.

Lathing.
Suspended ceilings.
Corner beads.
Patching.

Reinforced Concrete.

Forms.
Concrete.
Reinforcement.

Finishing.

Cement floors.
Marble.
Mosaic and tile.
Scagliola.
Terrazzo.
Concrete base for same.

Fire Proofing.

Hollow tile.
Book tile.
Iron fittings or rods.
Patching.

Structural Steel and Iron.

Castings.
Cartage.
Setting.
Inspection.
Shop drawings.
Painting.
Chimney.

Ornamental Iron.

Stairways.
Railings.
Elevator enclosures.
Bronze.
Prismatic lights.
Stair treads.

Hardware.

Nails.
Screws.
Bolts.
Ladders and fire escapes.
Straps.
Gratings.
Hinges.

Plumbing.

Gas fitting.

Electric Wiring.

Bells.
Speaking tubes.
Telephones.
Watchman's clocks.
Electric fixtures.
Lamps.
Pneumatic tubes.

Mail Chute.

Power Plant.

- Bollers.
- Boiler setting.
- Engines.
- Foundations.
- Dynamos.
- Switchboards, etc.
- Feed pump.
- Fire pump.
- Steam piping.
- Water intake.
- Water piping.
- Condenser.
- Hot well.

Sprinkler System.

Dust Collecting.

Heating.

- Ventilating.

Elevators.

- Passenger elevators.
- Freight elevators.
- Sidewalk lifts.
- Dumbwaiters.
- Signal device.
- Esculators.

Drawn Metal Covered Work.

- Metal frames.
- Tin doors.
- Shutters.

Sheet Metal and Roofing.

- Corrugated iron covering.
- Flashings.
- Cornices.
- Gutters.

To these items are added in grain elevator construction:

Sheet Iron Linings.

- Garners.
- Scales.
- Receiving hoppers.
- Shipping bins.
- Elevator heads.
- Spouting.

Machinery.

- Power transmission complete.
- Scales.
- Steam shovels.
- Car pullers.
- Elevator legs.
- Cleaner legs.

- Downpipes.
- Skylights.
- Roof covering.

Carpentry.

- Rough carpentry.
- Finishing work.
- Closet work.

Millwork.

- Frames.
- Sash.
- Trim.
- Filling.
- Priming.

Glass.

- Leaded glass.
- Screen prisms.
- Plate glass.
- Common glass.
- Glazing.

Painting.

- Varnishing.
- Tinting.
- Paper hanging.

General Expenses.

- Tools and tackles.
- Freight on same.
- Traveling expense.
- Liability insurance.
- Fire insurance.
- Storehouse and office sheds.
- Salvage.
- Depreciation.
- Office expenses.
- Inspection.
- Winding up.

Belting.

- Erection of machinery.
- Elevator house castings.
- Elevator boot tanks.
- Conveyors.
- Framing for conveyors

R. R. Track Doors.

Portable Spouts.

Scale Spouts.

Stand Pipes.

Hoods Over Loading Spouts.

Painting Name.

- Lettering house inside.

GENERAL SPECIFICATIONS FOR REINFORCED CONCRETE.

In General.—Special attention must be given to the quality of materials, labor and character of workmanship and these specifications are intended to include all that is considered best in theory and practice.

Only persons or firms thoroughly experienced in this class of work will be considered as bidders.

Bidders must submit drawings indicating their method of construction and calculation; the arrangement and nature of their steel reinforcement must be plainly stated and must have been approved by the building departments of such of the principal cities in the United States as have studied reinforced concrete and have embodied conditions for governing its use in their building codes, such as New York, Brooklyn, Minneapolis, St. Louis, Philadelphia, Washington, Cleveland, San Francisco and Chicago.

Dimensions of beams, columns, slabs and other parts of the construction indicated on the drawings shall be considered a minimum.

Samples of all materials must be submitted to the engineer for approval before being used and all rejected materials must immediately be removed from the building, if requested by the engineer.

No bids will be considered without submission to these conditions.

In calculations beams and slabs continuous over their supports may be computed for a bending moment of $\frac{pl^2}{10}$ and slabs continuous over supports on four sides may be computed for a bending moment $\frac{pl^2}{20}$. In all such cases sufficient reinforcement must be provided at the top of the slab to take care of all regular bending moments at the supports.

Particular attention must be given to the compression on under side of beams, where four beams or girders meet in a column.

Cement.—Standard specifications adopted by American Society for Testing Materials (see page 3):

The contractor shall notify the engineer as soon as each car of cement is placed, so samples may be taken therefrom without delay.

The cement shall be stored in a suitable weatherproof building having the floor blocked up from the ground and in a manner easy of access, and proper inspection and identification of each carload. Fourteen days at least shall be allowed for inspection and tests. The name and brand of manufacturer shall be on each bag.

Cement failing in the seven day requirement may be held awaiting the results of the 28 days' test before rejection.

Sand.—Shall be coarse, sharp, clean, a combination of coarse and fine, approximately 3 parts of coarse to 1 part of fine as hereinafter described. All sand shall pass through a screen of 5 meshes to the linear inch, approximately 75% of above shall be rejected by a screen of 12 meshes to the inch; the other quarter shall be fine sand. Salt water beach sand shall be washed, and any sand containing more than 3% loam or other impurities shall be rejected.

Gravel or Stone.—Gravel shall pass through a $\frac{3}{4}$ -in. mesh and be rejected by a $\frac{1}{4}$ -in. mesh. If salt water gravel is used it shall be washed clean the day previous to incorporation in the concrete. Stone shall be hard granite, trap rock or limestone, and crushed to pass a $\frac{3}{4}$ -in. ring, while rejected on a $\frac{1}{4}$ -in. ring.

Proportion.—The mixture shall be 1 volume of Portland cement as specified to 6 volumes of aggregates, whose respective quantities will give a maximum density.

To determine the minimum volume differently proportioned mixtures shall be placed in a vessel (say a piece of

wrought iron pipe 9 ins. diameter by 12 ins. high) and mixed and stirred with water until the proportion is found, which for the same combined weight gives the minimum volume.

Mixing.—Shall be done by batch mixer, the mixing being continued at least 3 minutes to each batch, resulting in a uniform, evenly tempered concrete. Enough water shall be added to result in a small quantity of free mortar appearing on top of the concrete under tamping. A competent foreman or inspector must at all times be watching the material going into the mixer, as well as the concrete coming out.

Placing Concrete.—Concrete shall be placed as rapidly as possible after leaving the mixer and shall at once be thoroughly puddled, spaded and tamped. Any concrete not placed after it is $\frac{1}{2}$ hour old shall be thrown away.

Concreting when started shall be vigorously carried on to completion. If concreting is stopped before an entire floor is completed the stop shall be made in the center of the beams and center of floor slabs. The plane where concrete work is stopped must be at right angles to the direction of the beam or slab. In no event shall work be terminated in beams or floor slabs where future shearing action becomes great, as at their ends or directly under a heavy concentrated load. Before work is resumed, the old work shall be thoroughly sprinkled with water and pure cement strewn over the joint to be abutted.

Wet all forms just before concreting.

Reinforcement.—Reinforcing steel shall be so arranged, designed and manufactured that it cannot be misplaced in the forms, and that it of itself maintains the proper distance from bottom and side of forms. It shall be calculated to provide for all horizontal and diagonal tension, vertical shear and compression where there is not sufficient concrete for the purpose. Concrete shall not be charged with more than 75 lbs. per sq. in. for shearing stress. No steel shall be closer to the form than $\frac{3}{4}$ in.

Steel rods shall have an elastic limit not to exceed 50,000 lbs. Wire in fabric shall have an elastic limit of 80,000 lbs.

or more. No iron shall be painted. A slight film of rust is not objectionable, but no scale will be permitted. All rods shall have ends bent 1 in. up at 90°. All steel shall bend cold 180° around its own diameter without cracking.

All reinforcement shall be anchored to its surroundings, structural steel, brick work, or masonry, and if rods are spliced they shall overlap each other at least 40 diameters for steel rods and 50 diameters for wire.

Expansion.—Expansion and contraction from temperature changes or other causes shall be taken up by distributing rods in slabs and walls, preferably in the shape of a wire fabric of high tensile strength wire.

Centering.—All centering must be true, rigid and properly braced, and able to carry the dead loads, including weight of construction considered as a liquid, without deflection. Forms are to be bolted and all slab forms arranged to be given a camber, so as to leave the slab perfectly horizontal after setting. If the reinforced concrete rests on structural steel or part of the reinforcement consists of structural steel, the forms shall be suspended from said steel, so that the latter may obtain its deflection or initial stresses due to the dead loads while the concrete is setting.

Removal of Forms.—Centering must not be removed until the concrete has thoroughly set and not until permission has been obtained from the engineer.

Beams shall remain supported for at least two weeks after all other false work has been removed. Columns shall not be given their full load in less than five weeks after concreting.

Freezing Weather.—Concrete shall be placed in freezing weather only when it cannot possibly be avoided. Precaution shall be taken to protect the finished work. Forms for such work shall be left in place at least three weeks longer than customary.

Protecting Work.—All floors shall be covered with sawdust and sprinkled for four days after concreting, and all

work exposed to the weather shall be kept moist by sprinkling or wet canvas for at least one week.

Fireproofing Structural Steel.—All structural steel shall be protected by 1:2½ mortar plastered on a wire fabric, such plastering being 1½ ins. thick.

Cement Finish.—Cement finish for floors shall not be leaner than 1:2, using in all cases a specially sharp, clean and gritty sand. It shall be troweled to a thoroughly smooth and even surface and be cut in squares not less than 8 ft. square.

Cement finish when applied to a concrete base must be laid at the same time as the concrete and shall not be less than ½ in. thick.

Stresses.—For hooped columns 750 lbs. per sq. in.

For latticed columns, 500 lbs. per sq. in.

For shearing stresses in concrete, 75 lbs. per sq. in.

For shearing stresses in steel, 10,000 lbs. per sq. in.

For tension stresses in steel, ½ of the elastic limit.

For tension stresses in wire, ⅓ of the elastic limit.

Extreme fiber stress in slabs, 800 lbs. per sq. in.

Extreme fiber stress in beams and girders, 750 lbs. per sq. in.

Ratio of moduli of elasticity of concrete and steel, 1 to 20.

The tensile strength of concrete shall not be considered.

Tests.—Floors shall be tested one month after the centering has been removed, to a uniformly distributed load equal to twice the safe live load. With this load there shall not be a deflection exceeding 1/400 of the span, and the floor shall return to its normal position after the removal of the load.

Finally.—At such time as the engineer directs and finally upon completion of the work the contractor shall remove all rubbish and surplus materials and repair such damage as may have been done to the work by other contractors in the course of ordinary building construction, and shall leave the premises in a neat, clean and perfect condition acceptable to the engineer.

STANDARD SPECIFICATIONS FOR CEMENT OF
THE AMERICAN SOCIETY FOR TEST-
ING MATERIALS.

(1) All cement shall be inspected.

(2) Cement may be inspected either at the place of manufacture or on the work.

(3) In order to allow ample time for inspecting and testing, the cement should be stored in a suitable weather-tight building having the floor properly blocked or raised from the ground.

(4) The cement shall be stored in such a manner as to permit easy access for proper inspection and identification of each shipment.

(5) Every facility shall be provided by the contractor and a period of at least twelve days allowed for the inspection and necessary tests.

(6) Cement shall be delivered in suitable packages with the brand and name of manufacturer plainly marked thereon.

(7) A bag of cement shall contain 94 pounds of cement net. Each barrel of Portland cement shall contain 4 bags, and each barrel of natural cement shall contain 3 bags of the above net weight.

(8) Cement failing to meet the seven-day requirements may be held awaiting the results of the twenty-eight day tests before rejection.

(9) All tests shall be made in accordance with the methods proposed by the Committee on Uniform Tests of Cement of the American Society of Civil Engineers, presented to the society January 21, 1903, and amended January 20, 1904, with all subsequent amendments thereto.

(10) The acceptance or rejection shall be based on the following requirements:

(11) **Natural Cement.**—Definition: This term shall be applied to the finely pulverized product resulting from the calcination of an argillaceous limestone at a temperature only sufficient to drive off the carbonic acid gas.

(12) The specific gravity of the cement thoroughly dried at 100° C. shall be not less than 2.8.

(13) **Fineness.**—It shall leave by weight a residue of not more than 10% on the No. 100 and 30% on the No. 200 sieve.

(14) **Time of Setting.**—It shall develop initial set in not less than ten minutes and hard set in not less than thirty minutes, nor more than three hours.

(15) **Tensile Strength.**—The minimum requirements for tensile strength for briquettes 1 in. square in cross section shall be within the following limits, and shall show no retrogression in strength within the periods specified:

(For example, the minimum requirement for the twenty-four hour neat cement test should be some value within the limits of 50 and 100 pounds, and so on for each period stated.)

Age.	Neat Cement.	Strength.
24 hours in moist air.....		50-100 lbs.
7 days (1 day in moist air, 6 days in water).....		100-200 lbs.
28 days (1 day in moist air, 27 days in water)....		200-300 lbs.

One part cement, three parts standard sand—

7 days (1 day in moist air, 6 days in water).....	25-75 lbs.
28 days (1 day in moist air, 27 days in water).....	75-150 lbs.

(16) **Constancy of Volume.**—Pats of neat cement about 3 ins. in diameter, ½ in. thick at center, tapering to a thin edge, shall be kept in moist air for a period of twenty-four hours.

(a) A pat is then kept in air at normal temperature.

(b) Another is kept in water maintained as near 70° F. as practicable.

(17) These pats are observed at intervals for at least 28 days, and, to satisfactorily pass the tests, should remain firm and hard and show no signs of distortion, checking, cracking, or disintegrating.

(18) **Portland Cement.**—Definition: This term is applied to the finely pulverized product resulting from the calcination to incipient fusion of an intimate mixture of properly proportioned argillaceous and calcareous materials, and to

which no addition greater than 3% has been made subsequent to calcination.

(19) **Specific Gravity.**—The specific gravity of the cement, thoroughly dried at 100° C., shall not be less than 3.10.

(20) **Fineness.**—It shall leave by weight a residue of not more than 8% on the No. 100 and not more than 25% on the No. 200 sieve.

(21) **Time of Setting.**—It shall develop initial set in not less than thirty minutes, but must develop hard set in not less than one hour, nor more than ten hours.

(22) **Tensile Strength.**—The minimum requirements for tensile strength for briquettes 1 in. square in section shall be within the following limits, and shall show no retrogression in strength within the periods specified.

(For example, the minimum requirement for the twenty-four hour neat cement test should be some value within the limits of 150 and 200 pounds and so on for each period stated.)

Age.	Neat Cement.	Strength.
24 hours in moist air.....		150-200 lbs.
7 days (1 day in moist air, 6 days in water)....		450-550 lbs.
28 days (1 day in moist air, 27 days in water)....		550-650 lbs.
One part cement, three parts sand—		
7 days (1 day in moist air, 6 days in water)....		150-200 lbs.
28 days (1 day in moist air, 27 days in water)....		200-300 lbs.

(23) **Constancy of Volume.**—Pats of neat cement about 3 ins. in diameter, ½ in. thick at center, and tapering to a thin edge shall be kept in moist air for a period of twenty-four hours.

(a) A pat is then kept in air at normal temperature and observed at intervals for at least 28 days.

(b) Another pat is kept in water maintained as near 70° F. as practicable, and observed at intervals for at least 28 days.

(c) A third pat is exposed in any convenient way in an atmosphere of steam, above boiling water, in a loosely closed vessel for five hours.

(24) These pats, to satisfactorily pass the requirements, shall remain firm and hard and show no signs of distortion, checking, cracking or disintegrating.

(25) **Sulphuric Acid and Magnesia.**—The cement shall not contain more than 1.75 per cent of anhydrous sulphuric acid (SO_3), nor more than 4 per cent of magnesia (MgO).

UNIFORM TESTS OF CEMENT.

(Condensed from methods recommended by the committee on uniform tests of cement of the Am. Soc. of C. E.)

Sampling.—The sample shall be a fair average of the contents of the package; it is recommended that where conditions permit one barrel in every ten be sampled.

All samples should be passed through a sieve having twenty meshes per linear inch, in order to break up lumps and remove foreign material; this is also a very effective method for mixing them together in order to obtain an average. For determining the characteristics of a shipment of cement the individual samples may be mixed and the average tested; where time will permit, however, it is recommended that they be tested separately.

Cement in barrels should be sampled through a hole made in the center of the staves, midway between the heads or in the head by means of an auger or a sampling iron similar to that used by sugar inspectors. If in bags it should be taken from surface to center.

Chemical Analysis.—The method proposed by the committee on Uniformity in the Analysis of Materials for the Portland Cement Industry, of New York Section of the Society for Chemical Industry, should be used as published in the journal of the society for January 15, 1902.

Specific Gravity.—The determination of specific gravity should be made with Le Chatelier's apparatus, and benzine (62° Baume naphtha) and kerosene free from water should be used in making the determination. The specific gravity is the weight of the cement divided by the displaced volume.

Fineness.—Fineness is determined on circular sieves about 7.87 ins. in diameter 2.36 ins. high and provided with a pan

1.97 ins. deep and a cover, and provided with a woven wire cloth from brass wire having the following diameters:

No. 100, 0.0045 ins.; No. 200, 0.0024 ins.

No. 100 should have 96 to 100 meshes to the linear inch.

No. 200 should have 188 to 200 meshes to the linear inch.

Normal Consistency.—This is best determined by Vicat needle apparatus, a description of which may be found in any of the treatises of cement or reinforced concrete.

Standard Sand.—The Sandusky Portland Cement Company of Ohio will furnish on application prepared sand from Ottawa, Ill., at the price only sufficient to cover the actual cost of preparation.

Form of briquette and molds to be for samples 1 in. square and 3 ins. long of the form illustrated in all text books.

Mixing.—Proportions by weight, the metric system, an average temperature of 21° C., dry sand, cement mixed on plate glass and hand kneading are required, and the molds should be filled at once, the material being pressed in firmly with the fingers and smoothed out with a trowel without ramming.

Storage of the Test Pieces.—Moist air for 24 hours and then immersed in water as near 21° C. as possible.

Tensile Strength.—Tests to be made on a standard machine without cushioning the points and immediately after removing the test pieces from the water.

Constancy of Volume.—Pats to be 2.95 ins. in diameter, 0.49 in. thick in center and tapering to a thin edge are submitted to a normal test and an accelerated test. The first, after immersion in water for 28 days, the other exposed in an atmosphere of steam. To pass these tests satisfactorily, the pats should remain firm and hard and show no signs of cracking, distortion or disintegration.

Miscellaneous Information.—To determine the quantity of materials required for a known mixture of concrete:

Example.—Materials required for 1,000 cu. yds. of 1-2-4 concrete:

1 bbl. cement 3.8 cu. ft., sand 30 per cent voids, stone 45 per cent voids.

1 bbl. cement 3.8 cu. ft. 3.80 cu. ft.

2 bbls. sand 7.6 cu. ft., 30 per cent voids. 5.32 cu. ft.

4 bbls. stone 15.2 cu. ft., 45 per cent voids. 8.36 cu. ft.

Loose material 26.6 cu ft. in place. 17.48 cu. ft.

1 bbl. cement produces 17.48 cu. ft. concrete.

GLOSSARY OF TERMS USED IN PLAIN AND REINFORCED CONCRETE.

Accelerated Test.—A test generally made to determine soundness of a cement, hastened by subjecting the test specimen to heat, sometimes dry heat, sometimes hot or boiling water. Such tests are determined by hours, while long time tests require days, months or even years.

Activity.—Relating to the rate of hardening of cement.

Aggregate.—The sand and gravel or crushed stone combined with cement in the formation of concrete.

Armored Concrete.—See Reinforced Concrete.

Bag of Cement.—Weighs 95 lbs. or is equivalent to one-fourth of a barrel.

Ball Mills.—Circular drums used in cement manufacture, grinding clinkers or stone between circumference of the rotating drums and forged steel balls contained in same.

Barrel of Cement.—Weighs 380 lbs. net, contains four bags of cement.

Batch.—The definite quantity of concrete made at one mixing.

Beton.—The French term for concrete.

Beton Armé.—The French term for reinforced concrete.

Blowing.—Effect of air bubbles on finished surface, due to overwet mixtures not properly stirred or tamped.

Bond, Mechanical.—See Mechanical Bond.

Bonding.—The uniting of one layer or course of concrete with another.

- Brique**.—A small brick of cement paste, mortar, or concrete having a definite area at the smallest section and made for testing purposes.
- Bush-hammered**.—A method of dressing stone, applicable to concrete, produced by dressing with a hammer having large point-like teeth on the striking face.
- Carrying Rods**.—Term used to designate those rods which carry or sustain the load; they extend lengthwise in the reinforced member.
- Cement**.—A preparation of calcined clay and limestone or their equivalents possessing the property of hardening into a solid mass when moistened with water.
- Cement Mortar**.—Mortar composed of cement, sand and water.
- Cement Sampler**.—A small tool used to take a sample of cement from a barrel, for testing purposes.
- Centering**.—A wooden form giving shape to a concrete arch while setting.
- Centers**.—Same as Centering.
- Checks**.—Same as hair cracks.
- Cinder Concrete**.—Concrete in which cinders are used as one of the aggregates.
- Concrete**.—A compact mass of broken stone, gravel or other suitable material mixed together with cement mortar and allowed to harden.
- Concrete Steel**.—See Reinforced Concrete.
- Construction Joint**.—The seam between two successive days' work in concrete laying.
- Corrugated Bar**.—A form of reinforcing steel, made by pressing the surface of a plain bar into a series of ridges or corrugations.
- Craze**.—Same as hair cracks—generally the result of too rich a mixture—occasionally a sign of unsound cement.
- Crusher Run**.—Crushed stone taken directly from the crusher with none of the fine material screened out.

- Distributing Rods.**—Term used to designate those rods which distribute the load over the carrying rods; they extend crosswise in the reinforced member.
- Dressing.**—The finish given to the surface of concrete.
- Dry Mix or Dry Mixture.**—A concrete mixed with so little water that very hard ramming is required to show moisture on the surface.
- Early Stage.**—The first part of the chemical action cement mortar undergoes after mixing, such as initial set and final set, both of which precede hardening.
- Efflorescence.**—A white discoloration appearing on the surface of concrete, due to the leaching out of soluble salts.
- Expanded Metal.**—A form of reinforcing material, made by cutting sheet steel in a series of short parallel rows, and drawing the sheet to form diamond-shaped meshes.
- Expansion Crack.**—Cracking in concrete work caused by expansion.
- Expansion Joint.**—A vertical joint or opening between two masses of concrete to allow for variations due to changes of temperature.
- Fabric, Wire.**—See Wire Fabric.
- Facing.**—A rich mortar placed on exposed surfaces to produce a smooth finish.
- Falsework.**—Wooden or other supports for holding concrete in position while setting.
- Ferro-cement.**—See Reinforced Concrete.
- Ferro-concrete.**—See Reinforced Concrete.
- Final Set.**—Is reached when a paste, mortar or concrete will support a pressure of the thumb without indenting—an arbitrary period of setting of concrete just preceding hardening.
- Fineness of Cement.**—Is the degree of pulverization, and for either cement or sand is measured in terms of the numbers of the two sieves between which it is held.
- Finishing.**—Working the concrete or mortar surface with steel trowels or similar tools, as for instance by brush, called brush finish.

Fireproofing.—Method of protecting structural parts that are subject to damage by fire, by covering them with a material that is not affected by high temperature, for instance reinforced concrete.

Floating.—Preparing the roughly spread mortar for the steel trowel by the use of a wooden or cork float. If this floating is used for a finish, it is called float-finish.

Flush.—To bring water to the surface of concrete by compacting or ramming.

Forms.—Wooden or other molds to give concrete the desired shape until hardened.

Gaging.—Determining the proportions of cement, sand, gravel or broken stone and water in concrete. Generally used in specifying the quantity of water that will produce a certain consistency.

Granolithic.—Concrete in which the stone aggregate is very finely crushed; its most general use being as a top surface for concrete walks.

Grappiers Cement.—A French cement made by grinding hard, under-burned nodules which have escaped disintegration in the manufacture of hydraulic limes.

Gravel.—Mixture of coarse rounded pebbles and sand, or pebbles without sand.

Grout.—A thin mortar composed of sand, cement and water; either poured or applied with a brush.

Hair Cracks.—Fine hair-like cracks on the surface of a cement or concrete structure which has stood for some time.

Hardening.—Commences after the final set of a cement, mortar or concrete and continues for a number of years.

High Carbon Steel.—A steel in which the elastic limit is not less than 52,500 lbs. per sq. inch.

Hinge Joints.—Joints which divide a structure into several sections, each one of which can expand independent of the others.

Hooped Concrete.—Concrete columns reinforced with wires wound spirally or placed in annular rings.

- Hydrated Lime.**—Made by mixing quicklime and water; the chemical formula is $\text{CaO} + \text{H}_2\text{O} = \text{CaO}_2\text{H}_2$.
- Hydraulic Cement.**—Any cement which sets or hardens under water.
- Initial Set.**—Takes place when a mass of cement begins to solidify; is defined by the length of time required, varying according to the kind of cement under test.
- Kahn Bar.**—A form of reinforcement named after the inventor, consisting of a special rolled section of steel with diagonal members sheared directly from the sides of the bar and bent upward.
- Kiln.**—A stationary or rotary furnace used in cement manufacture.
- Laitance.**—Pulpy, gelatinous fluid washed from cement that is deposited in water.
- Lean Mixture.**—A concrete containing a relatively small proportion of cement.
- Limestone.**—An aggregate for concrete, consisting largely of CaO , CO_2 , and SiO_2 .
- Loam.**—Earth or vegetable mold composed largely or entirely of organic matter.
- Matrix.**—A term sometimes used for Mortar.
- Mechanical Bond.**—Increased adhesion due to deformations in reinforcing material.
- Mix.**—A shortened term for Mixture.
- Mixer.**—A machine for mechanically mixing concrete.
- Mixture or Mix.**—Refers either to the proportions of materials composing concrete or to its consistency.
- Molds.**—Wooden or other forms used to hold concrete in the desired shape until hardened.
- Monolithic.**—Built in one solid, continuous piece.
- Mortar, Cement.**—A mixture of cement, sand and water. Very finely crushed stone may be used in place of the sand.
- Natural Cement.**—The finely pulverized product resulting from the calcination of an argillaceous limestone at a temperature only sufficient to drive off the carbonic acid gas.

Neat Cement.—Or cement paste, is cement mixed with water without the addition of any aggregate.

Paste, Cement.—A mixture of cement and water.

Pat.—A small quantity of neat cement spread upon glass for testing purposes.

Pointing.—Filling in joints or depressions on the face of concrete.

Portland Cement.—The finely pulverized product resulting from the calcination to incipient fusion of an intimate mixture of properly proportioned argillaceous and calcareous materials and to which no addition greater than 3 per cent has been made subsequent to calcination.

Puddling.—The mechanical or hand stirring of wet concrete in the mold when too wet to be tamped or rammed.

Pozzolan.—Same as Puzzolan.

Puzzolan.—An intimate mixture made by grinding together granulated furnace slag and slaked lime without further calcination, possessing the hydraulic qualities of cement.

Quaking Concrete.—Concrete mixed with that proportion of water which will cause it to quake like jelly when heavily tamped.

Quick Setting.—Term applied to cement which takes an initial set in a comparatively short time; is an arbitrary term.

Ramming.—Heavy compacting of concrete with a suitable tool.

Regaging.—Adding water to mortar which has become stiff and working same until plastic.

Reinforced Concrete.—Variously known as armored concrete, steel concrete, concrete steel, etc., is concrete in which is embedded steel in such form as to take up the tension and assist in resisting shear.

Reinforcement.—The iron or steel used in reinforced concrete.

Reinforcing.—Applying the reinforcement—also used in the same sense as reinforcement.

- Rich Mixture.**—A concrete containing relatively a large portion of cement.
- Roman Cement.**—The English term for natural cement.
- Rosendale Cement.**—A natural cement from the Rosendale district in eastern New York.
- Rotary Kiln or Rotary.**—Used in cement manufacture—see Kiln.
- Rubble Concrete.**—Concrete in which rubble stone are imbedded.
- Sampler.**—See Cement Sampler.
- Sand.**—Aggregate of particles of gravel passing a No. 5 sieve (having openings .16 in. wide), the grains being $1/16$ in. in diameter or under.
- Sand Cement.**—Same as Silica Cement.
- Scale.**—To flake off in thin layers.
- Screenings.**—A fine aggregate separated from crushed stone and used in the place of sand.
- Set.**—Solidification to such a degree that change of form will produce rupture. In cement, set begins when a Vicat needle 0.039 in. in diameter weighing 10.58 oz. penetrates only .20 in. into the mortar, and is complete when the needle will not penetrate at all. Approximately, when cement paste resists a light pressure of the finger nail.
- Shrinkage Cracks.**—Due to contraction of concrete on account of temperature changes.
- Silica Cement.**—Clean sand and Portland cement ground together.
- Slag Cement.**—Another name for Puzzolan Cement.
- Sloppy Concrete.**—Concrete mixed with that proportion of water which prevents it from being piled up in the barrow.
- Slow Setting Cement.**—That which requires two hours or longer in setting. The term is arbitrary.
- Soundness.**—Refers to property of not expanding, contracting or checking in setting.

- Standard Sand.**—Recommended by the American Society for Testing Materials is the natural sand from Ottawa, Illinois, screened to pass a sieve having 20 meshes per linear inch and retained on a sieve having 30 meshes per linear inch; the wires to have diameters of 0.0165 and 0.0112 ins., respectively, i. e., half the width of the opening in each case. Sand having passed the No. 20 sieve shall be considered standard when not more than 1 per cent passes a No. 30 sieve after one minute continuous sifting of a 500-gram sample.
- Steel-Concrete.**—See Reinforced Concrete.
- Tamp.**—To firmly compact concrete with a suitable tool.
- Test.**—An examination into the condition or quality of a cement, a concrete or its aggregates.
- Thacher Bar.**—A deformed bar used in reinforced concrete, named after its inventor.
- Top Surface.**—The exposed horizontal surface of cement or concrete work; usually applied to the finishing coat of sidewalks.
- Trap Rock.**—A heavy rock which when crushed forms an excellent aggregate for concrete.
- Trowel.**—A steel tool used in finishing a cement or concrete surface; also the act of using said tool.
- Tube Mill.**—A rotary mill or furnace used in the manufacture of cement in conjunction with ball mills.
- Twisted Steel.**—Reinforcing material made by twisting square steel bars.
- Underburned Cement.**—A cement burned at too low temperature; the clinker of such cement is lacking in density.
- Vassy Cement.**—The product obtained by heating limestone containing much clay at the lowest temperature that will decarbonate the lime; it sets very rapidly but hardens very slowly.
- Vicat Needle.**—An apparatus containing a needle named after its inventor, used in testing cement pats.

Voids.—The spaces between the particles of sand, gravel, crushed stone or other aggregate.

Wearing Surface.—Finished surface exposed to wear.

Wet Mix or Wet Mixture.—Concrete mixed with enough water so that little or no ramming is needed.

Wire Fabric.—A reinforcing material composed of wires crossing at right angles and secured at the intersections.

INDEX.

	Page		Page
Accident insurance.....	337	Bins, grain flowing from....	299
Adhesion, concrete to forms..	170	bridging action of grain in..	299
concrete to steel.....	71	capacity of	308
Aggregates, choice of.....	5	cement storage, Illinois	
cinders	13	Steel Co.	311
crushed stone.....	11	design of	299
graded, voids in.....	13	diagram of wheat pressure	
gravel	10	in	302
kinds of.....	4	friction of grain on con-	
slag	14	crete	304
voids in, determination of.	5	lateral and vertical pres-	
graded	13	sures, ratio between....	304
tables of.....	6	pressure of coal in.....	305
Angles, properties of.....	56	pressure of grain in, Ketch-	
Arch bridge, Grand River,		un's conclusions.....	309
Grand Rapids, Mich....	220	tables of.....	299
Santa Monica Viaduct, Cal-		ratio of grain to liquid	
ifornia	223	pressure	301
Arch centers, construction of..	216	vertical pressure in.....	303
examples of.....	217	Bridge construction.....	182
Grand River bridge.....	223	design	216
Pollasky bridge.....	218	Building construction, clear-	
removing, time and meth-		ing the site.....	157
ods of.....	220	concreting columns.....	160
Santa Monica viaduct....	224	in freezing weather.....	164
Arch construction, centers...216		walls	161
classification of arches...216		delivering concrete.....	160
concreting arch ring.....219		depositing concrete.....	160
Arch design, assumptions...205		eliminating forms in.....174	
constructing arch ring....205		finishing concrete surfaces.177	
dead load diagram.....207		forms and falsework.....164	
elastic theory, simplified..182		making the concrete.....159	
example of, by elastic		ordering materials.....158	
theory	205	placing reinforcement....158	
live load diagram.....209		separately molded members	
maximum fiber stresses...211		for	173
Beams, bending moments for. 67		sequence of operations...157	
calculation, numerical ex-		small tools for.....175	
ample	142	Building design, adhesion of	
reinforcement for, Coignet.108		concrete to steel..... 71	
Coularou	108	assumptions made in...65, 141	
frame systems.....109		beams	142
Hennebique	107	beams and girders.....107	
Locher	108	beams, bending moments.. 67	
loose rod	107	bracket connections.....139	
safe load and steel area ta-		columns	122
bles	109	dead loads, assumptions for 66	
stirrups, location of...69, 144		elasticity, modulus of..... 72	
tests of tee-beams..... 72		example of warehouse....141	
Bending moments, beams... 67		floors	88
slabs	68	foundations	73
maximum in	104	live loads, assumptions for. 67	

	Page		Page
Building Design (Continued).		Concrete (Continued).	
percentage of reinforcement	66	consistency, proper.....	25
roofs	131	definition of.....	17
slabs, bending moments for	68	depositing in building construction	160
stairs	131	finishes for, see Concrete finishes.	
steel or cast iron columns..	135	hair cracks in, eliminating..	178
stirrups, location of, in beams	69	joining new to old.....	162
stresses, allowable in concrete	67	mixing, hand or machine..	25
Cement, barrel of, volume... 2	2	requirements of.....	22
weight	2	mixtures, plain concrete..	23
color of.....	4	reinforced concrete.....	23
fineness	3	wet vs. dry.....	22
magnesia in, allowable....	3	proportioning, Fuller's rule for	18
packages for shipment....	1	Gillette's formula for....	19
Portland, definition of....	1	maximum density.....	21
setting, thumb nail test for	4	strength	19
time of.....	3	methods of.....	17
specifications for.....	2, 345	Thacher's tables for....	19
specific gravity.....	3	proportions for different classes of work.....	22
storage, requirements for..	2	protection from freezing..	163
strength, tensile.....	3	while setting.....	162
sulphuric acid in, allowable	3	sand for, best.....	8
testing, necessity of.....	3	small tools for.....	175
samples, method of taking	4	specifications for.....	340
test requirements for.....	3	stresses in, allowable.....	67
volume, constancy of.....	3	transporting in building construction	160
Channels, properties of.....	55	Concrete carts.....	176
Chimneys, calculation of....	319	Concrete finishes, dry mixtures for	179
approximate method....	321	mortar facing.....	178
core theory.....	320	painting and varnishing..	180
design of, summary of	324	plastering	180
points in.....	324	scrubbed and acid work....	179
forms, construction of....	327	tooling	180
Weber construction for....	325	types of.....	178
Wiederholt construction....	327	Concrete mixers, batch, classification of.....	25
wind pressure and velocity..	321	sizes and capacities.....	26
Cinders, choice and use of..	13	batch or continuous.....	25
Circles, areas and circumferences of	62	continuous, classification of sizes and capacities....	29
Columns, calculation of, numerical example.....	146	gravity, Hains.....	29
cast iron.....	135	Concrete, reinforced; definition of.....	1
classification of.....	122	names for, various.....	1
concreting, method of....	160	Conduits, calculations, character of	266
Euler's formula for.....	133	Weld's formula.....	267
hooped, calculation of....	124	cast pipe, stresses, concentrated load.....	270
Consider's formula for....	131	distributed vertical load	271
forms of.....	123	Talbot's tests.....	270
tables for designing....	125	tests on, summary of....	273
rectangular, calculation....	122	thickness and weight of..	270
forms of.....	122		
structural steel.....	135		
Concrete, adhesion of, to forms	170		
to steel.....	71		

Page	Page
Conduits (Continued).	Elastic Theory (Continued).
external pressure, calculation for267	thermal stresses204
flow of water in circular.....265	thickness of arch ring....197
internal pressure, calculation for.....266	Estimating, suggestions for.334
sewer, grades in.....266	Finishes for concrete, see
reinforcement for.....269	Concrete finishes.
soil, resistance to erosion	Floors, arch, forms of..... 95
by water263	Monier 95
velocity of water in, Chezy's formula for.....264	Roebling 95
Kutter's formula for.....264	Wuensch 95
water, erosive and transporting power of.....263	beam and tile..... 94
Connections, examples of....139	beam, forms of..... 93
Cost keeping, methods of....329	classification of..... 89
Costs, concrete culverts.....255	loads, specified..... 88
tanks290	manufactured, Siegwart... 96
timber and concrete grain elevators311	"Visintini" 96
timber and concrete piles. 79	"mushroom" system..... 97
Crushed stone, choice of.... 11	safety, factor of..... 89
crusher run..... 12	slab, calculation of..... 98
size of 11	Columbian 90
voids in, table of..... 14	Cottancin 91
Culverts, arch, design of....251	expanded metal..... 90
Great Northern Ry.....260	forms of..... 89
Kalamazoo, Mich.259	Matrai 91
standard, C., B. & Q. Ry.258	Monier 90
Culverts, box, assumptions	Roebling 91
for251	Forms, adhesion of concrete.170
covers, design of.....251	alignment of169
diagram for design of...252	chimneys327
sides, design of.....254	column, example of.....172
diagram for design of...254	combined steel and concrete construction.....172
standard, C., B. & Q. Ry. 262	design of.....166
Culverts, cost of.....255	fastening, methods of.....167
Dams, classification of.....277	grain elevator.....317
construction, types of....283	joints in.....168
curtain type284	lagging, thickness of.....169
half apron type.....284	lumber for, kinds of.....164
open front type.....283	railing for bridge.....222
pressures on immersed surface280	removing, time for.....170
stresses in, comparison of gravity and pressure dams277	retaining wall, care of....242
Elasticity, modulus of..... 72	construction, examples of.241
Elastic theory of arches....182	removing243
critical condition of loading for given section.....190	setting242
line of pressure for.....188	rotation in use of.....169
from dead load.....186	studs for, spacing of.....169
reactions from concentrated load.....183	tank297
successive steps in arch design186	Formula, Cain's, for retaining walls229
	Chezy's, for flow of water.264
	Consider's, for hooped columns124
	Euler's, for columns.....133
	for beams.....68, 69
	for deflection.....167
	for hooped columns.....124
	for parabola.....205
	for strength of mortar.... 15

Page	Page
Formula (Continued).	Modulus of elasticity..... 72
for wind pressure..... 79	of sections 64
Gillette's, for proportioning concrete 19	Moment of inertia of sections 64
Johnson's, for temperature cracks 230	Mortar, definition of..... 15
Kutter's, for velocity of water 264	retempered 17
parabolic line 102	sand for, best..... 7
Rankine's, for retaining walls 228	strength of, conditions gov- erning 15
Schaub's, for spacing stir- rups 70	formula for computing... 15
straight line..... 99	tests of, value of..... 16
Weld's, for thickness of pipes 267	volume of, with varying proportions of sand... 16
Foundations, concrete pile, see Piles, concrete.	weight of..... 16
concrete pile, types of.... 74	Painting concrete..... 180
mat 86	Piles, concrete, Chenoweth... 82
portable 86	corrugated 82
raft, calculation of, numeri- cal example..... 146	cost of, compared with wood 79
for warehouse..... 84	driving, methods of..... 82
slab, kinds of..... 83	Raymond 75
loads on..... 74	Simplex 79
types of, for buildings..... 73	types of..... 74
Girders, see Beams.	unpatented forms..... 82
Glossary of terms used..... 350	Plastering concrete..... 180
Grain, action of, in flowing	Profits, percentage to allow for 336
from bins 299	Rammers, cast iron..... 176
bridging action of..... 299	wood 177
pressures, table of..... 299	Reinforcement, American
Grain elevators, Canadian	hooped column..... 51
Pacific, Port Arthur, Ont. 315	American wire fabric..... 43
classification of..... 310	angles, properties of..... 56
forms for..... 317	channels, properties of.... 55
timber and concrete, com- parative cost..... 311	Coignet for beams..... 108
Gravel, characteristics of... 10	Columbian for floors..... 90
Hair cracks, eliminating, methods of..... 178	corrugated bars, weights and areas of..... 37
I-beams, properties of... 54, 55	Cottancin for floors..... 91
Inertia, moment of, for vari- ous sections..... 64	Coularou for beams..... 108
Inspection, necessity of..... 328	Cummings girder frame... 47
Loads, dead, assumed in	Cummings hooped column. 50
building design 66	cup bars, weights and sizes of 40
floor, specified 88	diamond bars, weights and areas of..... 38
live, assumed in building design 67	expanded metal 45
Manufactured articles..... 327	flats, areas of..... 34
Measuring box 176	weights of 35
Mixers (see Concrete mixers).	frame systems for beams... 109
	Hennebique, for beams.... 107
	hooped column 50
	I-beams, properties of.... 54
	Kahn rib metal..... 45
	Kahn trussed bar..... 48
	Locher for beams..... 108
	lock woven fabric..... 43
	loose rods for..... 36

Page	Page
Reinforcement (Continued).	Retaining Walls (Continued).
Luten truss 49	pressures on, Cain's theory, 228
Matrai, for floors..... 91	Coulomb's theory..... 228
mechanical bond..... 33	Rankine's theory..... 227
Monier, for floors..... 90	Trautwine's theory..... 228
monolith bars, weights and	Weyrauch's theory..... 227
areas of 49	Rankine's formulas for..... 228
frame 49	reinforced concrete, beam
hooped column..... 51	type, foundation..... 235
percentage of..... 32, 66	vertical beam..... 234
pin-connected girder frame 50	with counterforts..... 240
placing, in building con-	foundations 241
struction 158	pressure, calculation of..... 237
rods, areas of square and	vertical slab..... 239
round 32	specifications for..... 248
weights of square and	temperature cracks..... 230
round 32	thrust 230
Roebing for floors..... 91	Rock crushers, capacity of... 12
round rods for..... 36	gyratory, sizes and capac-
sections, properties of vari-	ity 13
ous 64	Roofs, forms of..... 134
Smith hooped column..... 52	Sand (see also Screenings).
square rods for..... 36	Sand, cleanness, requirements
steel, adhesion of concrete	for 8
to 71	concrete, best for..... 8
high vs. low carbon..... 30	definition of..... 6
medium 31	mortar, best for..... 7
strength of..... 30	selection of..... 6
structural steel..... 53	standard, definition of..... 10
styles of..... 34	voids in, conditions govern-
Thacher bars, weights and	ing 9
areas 39	table of 9
tie-locked fabric..... 43	theory of..... 9
twisted bars, weights and	washing, method of..... 8
areas 36	weight of 10
twisted lug bars, weights	Screenings, characteristics
and areas of..... 41	required 10
unit, beam and girder.... 47	Section modulus 64
"Unit" frame..... 48	Sections, properties of..... 64
welded wire fabric..... 44	Sewers, see Conduits.
wire, standard gages..... 42	Slabs, bending moments for. 68
Reservoirs, see Tanks.	maximum 104
Retaining wall design,	calculation, notation used. 98
masonry, example of..... 231	parabolic line formula.. 102
reinforced concrete beam	straight line formula... 99
type, example of..... 234	thickness and reinforce-
Retaining walls, backfilling. 230	ment, table showing... 106
Cain's formulas..... 229	Slag, aeration of..... 14
expansion joints..... 230, 243	Soils, bearing power of..... 74
form construction for..... 241	Specifications, Portland ce-
Great Northern Ry..... 245	ment 345
masonry, crushing of, sta-	reinforced concrete con-
bility against..... 233	struction 340
overturning; stability	retaining wall construction. 248
against 242	Stairs, kinds of construction. 134
resultant pressure, calcu-	stirrups, location of, in
lation of..... 232	beams 69, 144
sliding, stability against. 232	Stresses, allowable in con-
Paris exposition, 1889..... 244	crete 67

What is Engineering-Contracting?

Engineering-Contracting is a weekly journal for civil engineers and contractors, edited by Halbert P. Gillette, M. Am. Soc. C. E. author of the "Handbook of Cost Data" and other books for Engineers and Contractors. Engineering-Contracting might be termed a serial sequel to this "Handbook," for no issue is printed that does not contain valuable cost data. This feature alone makes the paper one that no civil engineer or contractor can afford to be without. Mr. Gillette has just completed his appraisal of all the railways in the State of Washington, acting as Chief Engineer for the Railroad Commission. Data of cost of all kinds of railway structures, secured from the original records of railways, are now being printed in Engineering-Contracting. The "Methods and Cost" articles that are appearing cover so wide a range that every engineer and contractor should read each issue. Mr. Daniel J. Hauer has recently become one of our associate editors. Mr. Hauer is well known as an authority on earth and rock excavation. The other associate editors include: Mr. Charles S. Hill, joint author with Mr. A. W. Buel of "Reinforced Concrete," and for eighteen years on the Editorial staff of Engineering News; Mr. C. T. Murray, for many years editor of the construction news department of Engineering News; Mr. F. A. Smith, author of "Railway Curves," "Maintenance of Way Standards" and "Standard Turnouts." The entire staff includes fourteen persons formerly with other leading engineering journals, thus placing every department in charge of experienced and competent men.

Engineering-Contracting is published every Wednesday and costs only \$2.00 for the 52 issues.

SAMPLE COPIES FREE.

ENGINEERING-CONTRACTING

355 Dearborn Street, Chicago.

Handbook of Cost Data

By

HALBERT P. GILLETTE, M. Am. Soc. C. E.
Editor "Engineering-Contracting"

"Cost Data" has broken all records for the sale of technical books. Over 10,000 copies were sold in less than two years; 1,600 in last three months. The book has over 600 pages of **actual costs** taken from the **private records** of **engineers and contractors**, and so itemized and analyzed as to be of **inestimable value** to any person who has to do with making **bids** and **estimates** or in checking **estimates**. The book covers the whole field of contract work, giving the cost of labor and materials required for every kind of construction, from the laying of sod to the building of reinforced concrete sewers. No detail of contract work has been too small to be described and recorded. Wages and prices of material are given in every case, so that proper substitution can be made where conditions differ. It gives also valuable data on **methods of construction**, thus enabling foremen to handle work in the most economical manner possible.

The general headings are:

- Cost-Keeping, Preparing Estimates, Organization of Forces, etc.
- Cost of Earth Excavation.
- Cost of Rock Excavation, Quarrying and Crushing.
- Cost of Roads, Pavements and Walks.
- Cost of Stone Masonry.
- Cost of Concrete Construction of All Kinds.
- Cost of Water-Works.
- Cost of Sewers, Vitrified Conduits and Tile Drains.
- Cost of Piling, Trestling and Timberwork.
- Cost of Erecting Buildings.
- Cost of Steam and Electric Railways.
- Cost of Bridge Erection and Painting.
- Cost of Railway and Topographic Surveys.
- Cost of Miscellaneous Structures.

**Flexible leather, gilt edges; 622 pages;
illustrated; \$4.00 net, postpaid.**

24-page circular, showing contents and sample pages, will be mailed **FREE** on request.

The Myron C. Clark Publishing Co.

355 Dearborn Street: Chicago.

Concrete Construction Methods and Costs

By HALBERT P. GILLETTE
and
CHARLES S. HILL

This book is unique among all the books on concrete. It is devoted exclusively to the **methods and costs** of concrete construction, and it gives detailed information regarding every phase of that work. It tells what an engineer or contractor needs in **estimating the cost** and in **reducing the cost** of concrete work, both plain and reinforced. The various designs of forms and centers and the layout of plant for mixing, conveying and placing concrete, receive the most complete treatment ever given to these important subjects.

The book should be purchased by every contractor and by every concrete foreman and superintendent, for it is the best "correspondence school" on practical concrete construction that has ever appeared in print.

16-page circular FREE.

Cloth, 6x9 inches; 700 pages; 306 illustrations;
price \$5.00 net, postpaid.

THE MYRON C. CLARK PUBLISHING CO.

355 Dearborn Street, Chicago

Concrete and Reinforced Concrete Construction

By

HOMER A. REID, Assoc. M. Am. Soc. C. E.

This is the most complete and comprehensive book ever written on this subject. It is, in fact, a combination of several books in one—all original, carefully written and up-to-date. It has **200** working drawings of bridges, bridge piers and culverts; **60** working drawings of sewers, water mains and reservoirs; **30** working drawings each of retaining walls and dams; **200** working drawings of buildings and foundations, including shops, roundhouses, etc.

It has more text pages, more drawings and more tables of test data on concrete and reinforced concrete construction than any other book ever published. No other book on concrete contains one-tenth so much of the very latest data on tests, theory and practice.

**906 pages, 715 illustrations,
70 tables; \$5.00 net, postpaid.**

16-page Table of Contents free.

The Myron C. Clark Publishing Co.

355 Dearborn St., Chicago

Ready January 15, 1909

POCKET-BOOK FOR **CIVIL ENGINEERS**

By ALBERT I. FRYE, M. Am. Soc. C. E.

After a lifetime spent in accumulating material, and nearly four years of hard grinding work in putting this matter in shape for publication, we are happy to announce a comprehensive and up-to-date pocket-book for civil engineers—not a scrap book, but a condensed treatise on civil engineering, filled with data and tables, many of which have never before been published. For instance: The author spent twelve weeks of constant labor calculating and checking one new table, the need of which had been shown him by his own experience as an engineer.

Thus there is crowded into the 1,200 pages a vast amount of matter that makes this the one book that no civil engineer or contractor can afford not to have. It is an epitome of modern civil engineering knowledge—a whole library condensed into one flexible leather pocket-book.

Price only \$5.00 net, postpaid.

Send for pamphlet giving table of contents, sample pages, etc.

THE MYRON C. CLARK PUBLISHING CO.

355 Dearborn Street, Chicago

Theory and Design OF Reinforced Concrete Arches

A Treatise for Engineers and Technical
Students.

By ARVID REUTERDAHL, Sc. B., A. M.
Chief of Bridge Department, Engineering Department,
City of Spokane, Wash.

The books which have heretofore been published on this subject are either so mathematically abstruse or leave so much to the reader to demonstrate for himself, that they are of little value to the general practitioner or to the technical student whose mathematical ability is not of exceptional order. **These objections have been overcome in this book. Every principle is explained thoroughly—there are no missing steps in the mathematics.**

The book should be in the hands of every engineer who has concrete bridges to design and of every student of the theory and practice of concrete bridge design.

Cloth, 6x9 inches; 132 pages; numerous diagrams and tables;
price \$2.00 net, postpaid.

THE MYRON C. CLARK PUBLISHING CO.
355 Dearborn Street, Chicago

Reinforced Concrete

A Manual of Practice

By ERNEST McCULLOUGH, C. E.

This book was written for the practical concrete worker—the man on the job—who has not the requirements of statics and the theories of the mathematician at his tongue's tip but who desires, in plain words, the fundamentals of correct design and the practice of sound and economical construction work.

Cloth, 5x7 $\frac{1}{2}$ inches; 136 pages; illustrated;
price \$1.50 net, postpaid.

Field System

By FRANK B. GILBRETH

This book was written by one of the largest general contractors in the world, and contains nearly 200 pages of rules and instructions for the guidance of his foremen and superintendents. It is the outgrowth of over twenty years of experience in the contracting business, and embodies scores of suggestions for economizing and for increasing the output of the men on the job. Mr. Gilbreth is the contractor who made the "Cost-plus-a-fixed-sum-contract" famous; in doing so, he has likewise made famous Gilbreth's "Field System," only a few excerpts from which have heretofore appeared in print.

One thousand copies were sold in the first ten days.

In making public his "Field System" Mr. Gilbreth is performing a service to the public that is comparable with the action of a physician in disclosing the secret of his success in curing a disease. The disease that Gilbreth's "Field System" aims to cure is the hit or miss method of doing contract work. System supplants slovenliness, and makes sloth an absolute impossibility.

200 pages, with illustrations; bound in leather;
price \$3.00 net, postpaid.

THE MYRON C. CLARK PUBLISHING CO.

355 Dearborn Street, Chicago

Cements, Mortars and Concretes

—Their Physical Properties

An up-to-date Compendium of Reliable Tests of Cements,
Mortars and Concretes

By MYRON S. FALK, Ph. D.

Instructor in Civil Engineering, Columbia University.

This book contains a very complete report of the results of tests made during the past fifteen years, and gives the results in tables and diagrams classified according to subjects. This is a reference book that should be in the library of every civil engineer. The contents include chapters on Chemical Properties of Cement, Physical Tests of Cement, General Physical Properties, Elastic Properties in General, Tensile Properties, Compressive Properties, Report on Uniform Tests of Cement by the Special Committee of the American Society of Civil Engineers, and Constitution of Cement.

Cloth, 6x9 inches; 184 pages; illustrated;
price \$2.50 net, postpaid.

Practical Cement Testing

By W. PURVES TAYLOR, M. S., C. E.

Engineer in Charge of Philadelphia Municipal Testing Laboratories.

This is the first practical and exhaustive treatise on this important subject. It has already been adopted as a text book by the University of Pennsylvania and other technical schools. Each chapter contains a minute description of the methods followed in the author's laboratory and many valuable suggestions as to the "how" and "why" of cement testing. The observations on the interpretation of results, one of the most difficult tasks of the novice, are especially pertinent and are expressed in a fair and conservative manner.

The book is so complete that it can be put in the hands of a young engineer with confidence that it will enable him to make reliable tests on cement. The wealth of photographs and line cuts furnishes the pictorial examples of how to conduct cement tests, and the 300 pages of text are so explicit that even the most inexperienced man can soon learn the art of cement testing. Yet this book has not a superfluous paragraph. The list of chapters includes: (1) Classification and Statistics, (2) Composition and Constitution, (3) Manufacture, (4) Inspection and Sampling, (5) The Testing of Cement, (6) Specific Gravity, (7) Fineness, (8) Time of Setting, (9) Tensile Strength, (10) Soundness, (11) Chemical Analysis, (12) Special Tests, (13) Approximate Tests, (14) Practical Operation, (15) Other Varieties of Cement than Portland, (16) Specifications (The Author's, Am. Soc. C. E., Am. Soc. Test. Mat.; Soc. Chem. Indust.; Corps Eng. U. S. A.; British Standard, Can. Soc. C. E.)

Cloth, 6x9 inches; 330 pages; 142 illustrations;
58 tables; \$3.00 net, postpaid.

THE MYRON C. CLARK PUBLISHING CO.

355 Dearborn Street, Chicago

“Earth and Rock”

Successor to

“The Dirt Mover”

“Earth and Rock” is the only journal in the United States devoted to the interests of contractors for earth and rock excavation. It combines in its special field the qualities both of a newspaper and of a technical journal. Its news of contract work and contractors covers the whole country, and is accurate and up-to-date. Its technical articles are of the most practical character and are prepared by experts.

“Earth and Rock” is published under the editorial management of Mr. Halbert P. Gillette, M. Am. Soc. C. E., author of “Rock Excavation—Methods and Cost,” “Earthwork and Its Cost,” etc. Mr. Gillette is assisted in his work by Mr. Daniel J. Hauer, an engineer and contractor of twenty-five years’ experience and a well-known writer on earth and rock excavation, and by a staff of trained editors and news gatherers.

“Earth and Rock” is a live, progressive journal with a large subscription list and a representative advertising patronage. It should be read by every contractor and engineer interested in earth and rock excavation.

Subscription price \$1.00 per year.

THE MYRON C. CLARK PUBLISHING CO.

355 Dearborn Street, Chicago

Some of Our Books

BERG, "Timber Test Records".....	\$0.50
FALK, "Cements, Mortars and Concretes".....	2.50
FISH, "Mathematics of Paper Location of a Railroad".....	.25
GILBRETH, "Field System".....	3.00
GILLETTE, "Hand Book of Cost Data".....	4.00
"Rock Excavation, Methods and Cost".....	3.00
"Earthwork and Its Cost".....	2.00
"Economics of Road Construction".....	1.00
GILLETTE AND HILL, "Concrete Construction, Methods and Cost".....	5.00
HEIDENREICH, "Engineers Pocketbook of Reinforced Concrete".....	3.00
INSKIP, "Tables of Logs and Squares".....	3.00
KINDELAN, "Trackman's Helper".....	1.50
LAVIS, "Railroad Location Surveys and Estimates".....	3.00
LOVELL, "Practical Switchwork".....	1.00
MAYER, "Telephone Construction, Methods and Cost".....	3.00
MCCULLOUGH, "Engineering Work in Towns and Cities".....	3.00
"Reinforced Concrete, A Manual of Practice.".....	1.50
"Business of Contracting".....	.50
REID, "Concrete and Reinforced Concrete Construction".....	5.00
REUTERDAHL, "Theory and Design of Reinforced Concrete Arches".....	2.00
SMITH, "Maintenance of Way Standards on American Railroads".....	1.50
"Railway Curves for Practical Trackmen".....	1.00
"Standard Turnouts on American Railroads".....	1.00
TAYLOR, "Practical Cement Testing".....	3.00
TAYLOR, "Surveyors' Hand Book".....	2.00

In Preparation, December, 1908—Ready Soon

FRYE, "Pocket Book for Civil Engineers"
GILBRETH, "Bricklaying System."
GILLETTE AND DANA, "Cost Keeping and Construction Economics."
GILLETTE AND HAUER, "Earth Excavation and Embankments, Methods and Cost."
MCCULLOUGH, "Engineering Contractors' Hand Book."
PECKHAM, "Solid Bitumens: Their Physical and Chemical Analysis, Together with a Treatise on the Chemical Technology of Bituminous Pavements."
SEELY, "How to Become an Inspector on Public Work."
SLIPPY, "Economics of Telephone Cable Work."

We have in preparation also a number of other very valuable new books, several of which will soon be ready for press.

If you want sample pages, circulars or catalogs covering ANY class of books for engineers, architects, contractors, chemists or railway men, SEND US A POSTAL CARD.

THE MYRON C. CLARK PUBLISHING CO.

355 Dearborn Street, Chicago

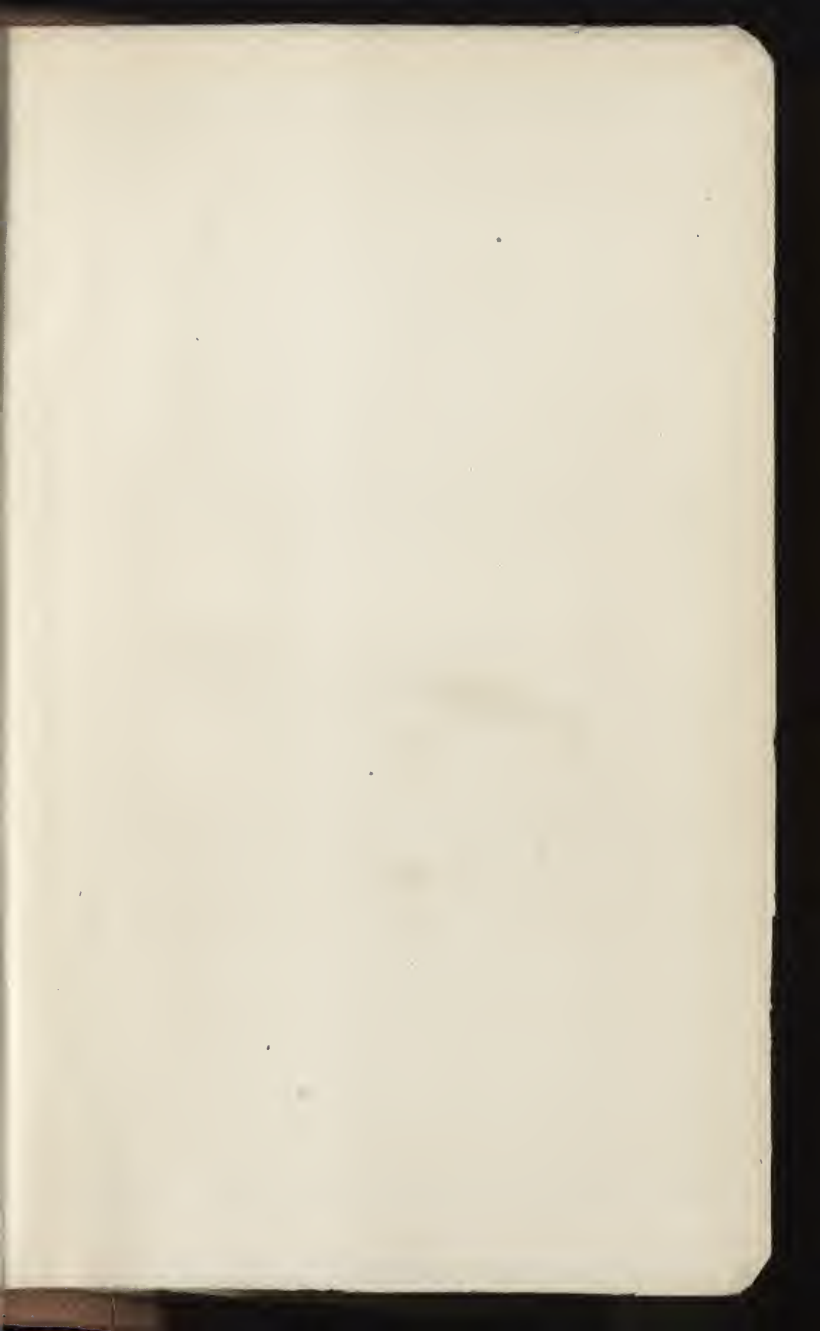

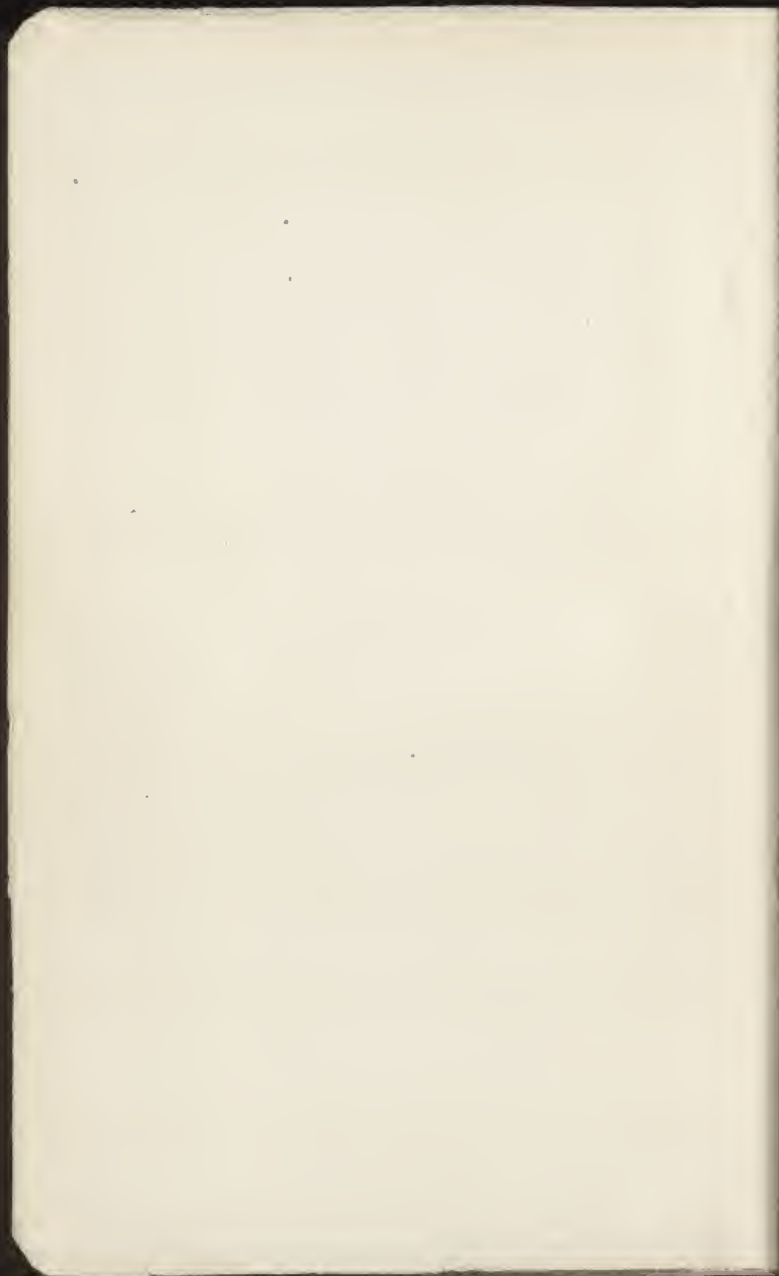



90-87479



GETTY CENTER LIBRARY



3 3125 00070 7782

