

Digitized by the Internet Archive  
in 2018 with funding from  
Getty Research Institute

<https://archive.org/details/internationalstu3212unse>















THE INTERNATIONAL  
STUDIO AN ILLUSTRATED  
MAGAZINE OF FINE AND  
APPLIED ART

VOLUME THIRTY-TWO

COMPRISING JULY, AUGUST, SEPTEMBER AND  
OCTOBER, 1907; NUMBERS 125 TO 128

NEW YORK OFFICES OF THE INTER-  
NATIONAL STUDIO  
JOHN LANE COMPANY, 110-114 WEST 32d ST.  
MCMVII



# THE INTERNATIONAL STUDIO VOL. XXXII

COMPRISING JULY, AUGUST, SEPTEMBER AND OCTOBER, 1907  
NUMBERS 125 TO 128

## SUBJECTS AND AUTHORS

	PAGE
AN AMERICAN Village Bank. By Henry H. Saylor. Eight Illustrations . . . . .	ciii
Ashbee, C. R., Architect. The "Norman Chapel" Buildings at Broad Campden, in Gloucestershire. Ten Illustrations . . . . .	289
BALDRY, A. Lys.	
The Paintings of Mr. Charles Sims. Eleven Illustrations . . . . .	89
Robert W. Little, R.W.S. A Review of his work. Nine Illustrations . . . . .	173
Batik Making, The Craft of. By Mabel Tuke Priestman. Five Illustrations . . . . .	lxxxvii
Beaux-Arts, The Salon of the Soci�t� Nationale des. Nine Illustrations . . . . .	126
Bentz, F. Mannheim Tercentenary Exhibition. Fourteen Illustrations . . . . .	189
Binns, Charles F. The Possibilities of Clay. Seven Illustrations . . . . .	lxvi
Bits of Old China. By Inglis Sheldon-Williams. Five Illustrations . . . . .	111
Brangwyn's, Mr., Decorative Panels in the British Section, the Venice Exhibition. By A. S. Covey. Eleven Illustrations . . . . .	9
Brinton, Selwyn. Seventh International Exhibition of Art at Venice, 1907. Fourteen Illustrations . . . . .	269
CALIFORNIA Patio, Two Types of the. By Henrietta Keith. Four Illustrations . . . . .	
Charlton, W. H., Leaves from the Sketch-Book of. Six Illustrations . . . . .	182
Coburn, Frederick W. Edmund C. Tarbell. Eleven Illustrations . . . . .	lxxv
Colored Stencil Drawings of Ludwig Jungnickel. Eight Illustrations . . . . .	21
Covey, A. S. The Venice Exhibition. Mr. Brangwyn's Decorative Panels in the British Section. Eleven Illustrations . . . . .	9
Cox, Kenyon, The Work of. By Minna C. Smith. Eleven Illustrations . . . . .	iii
Current Art Events. Two Illustrations . . . . .	xciv
DANILOVICZ, C. de. Talashkino: Princess Tenishef's School of Russian Applied Art. Ten Illustrations . . . . .	
Designer's Approach to His Problem, The. By James Parton Haney. Thirteen Illustrations . . . . .	cxxxv
Dibdin, E. Rimbault. Mr. E. A. Hornel's Paintings of Children and Flowers. Seven Illustrations . . . . .	3
ESSEX County Court House, Newark, N. J. Three Illustrations . . . . .	
Exhibition of Art at Venice, 1907, The Seventh International. By Selwyn Brinton. Fourteen Illustrations . . . . .	269
Exhibition of the Mannheim Tercentenary. Fourteen Illustrations . . . . .	189
Exhibition of the New Gallery. The Twentieth Summer. Ten Illustrations . . . . .	50
Exhibition of the Royal Academy. 1907. Nineteen Illustrations . . . . .	29
Exhibition, The Venice. Mr. Brangwyn's Decorative Panels in the British Section. Eleven Illustrations . . . . .	9
FLOOR Covering in Summer—Matting. Five Illustrations . . . . .	
Franz, Henri. Louis Gillot, Painter and Engraver. Seven Illustrations . . . . .	105
Froehlich, Mrs. Hugo, Recent Work by. By Eva Lovett. Six Illustrations . . . . .	xc1
GARDEN City, The, and Its Units. Three Illustrations . . . . .	
Gillot, Louis, Painter and Engraver. By Henri Franz. Seven Illustrations . . . . .	105
HANEY, James Parton. The Designer's Approach to His Problem. Thirteen Illustrations . . . . .	
Hornel's, E. A., Paintings of Children and Flowers. By E. Rimbault Dibdin. Seven Illustrations . . . . .	3
JUNGNICKEL, Ludwig, The Colored Stencil Drawings of. Eight Illustrations . . . . .	
Keith, Henrietta. Two Types of the California Patio. Four Illustrations . . . . .	1vi
Khnopff, Fernand. Alexandre Struys, A Belgian Painter. Seven Illustrations . . . . .	283
King, M. L. Practical Bookbinding. I. Twenty-five Illustrations . . . . .	cxx
LACE and Lace Making at Pratt Institute. By Eva Lovett. Four Illustrations . . . . .	
Lay Figure . . . . .	lviii
On the Study of Color . . . . .	96
On Receiving Impressions . . . . .	170
On Choosing a Subject . . . . .	254
On Misdirected Ingenuity . . . . .	338
Leaves from the Sketch-Book of W. H. Charlton. Six Illustrations . . . . .	182
Little, Robert W., R.W.S. A Review of His Work. By A. Lys Baldry. Nine Illustrations . . . . .	173

## Index

	PAGE
Lockwood, Wilton. An American Portrait Painter. By M. I. G. Oliver. Six Illustrations . . . . .	262
Lovett, Eva	
Lace and Lace Making at Pratt Institute. Seven Illustrations . . . . .	lviii
Recent Work by Mrs. Hugo Froehlich. Six Illustrations . . . . .	xci
MANNHEIM Tercentenary Exhibition. By F. Bentz. Fourteen Illustrations . . . . .	189
"Marie Antoinette" Shawl. Two Illustrations . . . . .	lxi
Mechlin, Leila. The Worcester Art Museum. Twelve Illustrations . . . . .	xxxix
Millet, Frank D., The Domestic Pictures of. By Charles M. Skinner. Ten Illustrations . . . . .	cxi
Modern Stage Mounting in Germany. II. Orlik's "A Winter's Tale," at Berlin. By Prof. Hans W. Singer. Five Illustrations . . . . .	219
NATIONAL Art Competition at South Kensington, 1907. Ten Illustrations . . . . .	296
New Gallery, The Twentieth Summer Exhibition of the. Ten Illustrations . . . . .	50
"Norman Chapel" Buildings at Broad Campden, in Gloucestershire. By C. R. Ashbee, Architect. Ten Illustrations . . . . .	289
OLIVER, Maude I. G.	
The Photo-Secession in America. Fifteen Illustrations . . . . .	199
An American Portrait Painter. By Wilton Lockwood. Six Illustrations . . . . .	262
PAINTING and Painters. Seven Illustrations . . . . .	xcvii
Photo-Secession in America. By Maude I. G. Oliver. Fifteen Illustrations . . . . .	199
Pica, Vittorio. A Painter of Gardens: Santiago Rusinol. Eleven Illustrations . . . . .	98
Polish Artists of To-day, Notes on Some. Fifteen Illustrations . . . . .	115
Possibilities of Clay. By Charles Binns. Seven Illustrations . . . . .	lxvi
Potter's, Louis. Bronze Groups of Alaskan Indians. Eight Illustrations . . . . .	xvii
Practical Bookbinding. I. By M. L. King. Twenty-five Illustrations . . . . .	cxx
Pratt Institute, Lace and Lace Making at. By Eva Lovett. Seven Illustrations . . . . .	lviii
Priestman, Mabel Tuke	
Weaving in a Hand Loom. Nine Illustrations . . . . .	xxx
The Craft of Batik Making. Five Illustrations . . . . .	lxxxvi
RECENT Designs in Domestic Architecture. Ten Illustrations . . . . .	215
Recent Publications in Architecture and Decoration. Three Illustrations . . . . .	xxvii
Royal Academy Exhibition. 1907. Nineteen Illustrations . . . . .	29
Rusinol, Santiago. A Painter of Gardens. By Vittorio Pica. Eleven Illustrations . . . . .	98
SALON of the Societé Nationale des Beaux-Arts. Nine Illustrations . . . . .	126
Saylor, Henry H. An American Village Bank. Eight Illustrations . . . . .	cii
School Notes. Three Illustrations . . . . .	xxiv
Sheldon-Williams, Inglis. Bits of Old China. Five Illustrations . . . . .	111
Skinner, Charles M. The Domestic Pictures of Frank D. Millet. Ten Illustrations . . . . .	cxi
Sims, Charles, The Paintings of. By A. Lys Baldry. Eleven Illustrations . . . . .	89
Singer, Prof. Hans W. Modern Stage Mounting in Germany. II. Orlik's "A Winter's Tale," at Berlin. Five Illustrations . . . . .	219
Smith, Minna C. The Work of Kenyon Cox. Eleven Illustrations . . . . .	iii
South Kensington, The National Art Competition at, 1907. Ten Illustrations . . . . .	296
Struys, Alexandre, a Belgian Painter. By Fernand Khnopff. Seven Illustrations . . . . .	283
Studio Talk	
Forty-two Illustrations . . . . .	60
Thirty-six Illustrations . . . . .	140
Forty-three Illustrations . . . . .	225
Forty Illustrations . . . . .	304
TALASHKINO: Princess Tenishef's School of Russian Applied Art. By C. De Danilovicz. Ten Illustrations . . . . .	135
Tarbell, Edmund C. By Frederick W. Coburn. Eleven Illustrations . . . . .	lxxv
Thomas, Grosvenor, The Landscape Paintings of. By W. K. West. Nine Illustrations . . . . .	257
Twentieth Summer Exhibition of the New Gallery. Ten Illustrations . . . . .	50
VENICE, The Seventh International Exhibition of Art, 1907. By Selwyn Brinton. Fourteen Illustrations . . . . .	269
WATERHOUSE, Alfred, R.A., A Note on the Water-Color Sketches of. Three Illustrations . . . . .	278
Weaving in a Hand Loom. By Mabel Tuke Priestman. Nine Illustrations . . . . .	xxx
West, W. K. The Landscape Paintings of Mr. Grosvenor Thomas. Nine Illustrations . . . . .	257
Worcester Art Museum. By Leila Mechlin. Twelve Illustrations . . . . .	xxxix

## LIST OF ILLUSTRATIONS

ADAMS, John Quincy. Portraits . . . . .	151, 155
Adelberg, Maria. Embroidered Cushions . . . . .	81
Adie, Edith Helena. Painting . . . . .	141
Allen, Charles J. Medals . . . . .	229
Ameseder, Ed. Painting . . . . .	152
Arzenberg. Interior . . . . .	232
Ashbee, C. R., Architect. Exteriors, Interiors . . . . .	289, 290, 291, 292, 293, 294, 295

# Index

	PAGE
Auburtin, I. F. Painting . . . . .	134
Axentowicz, Theodore. Painting and Portrait . . . . .	119, 121
BAAR, Hugo. Paintings . . . . .	149
Ball, A. S. Interiors . . . . .	233, 234, 235
Bantzer, Karl. Painting . . . . .	191
Bartlett, C. W. Painting . . . . .	57
Batik Making	
A Practical Implement . . . . .	lxxxvii
Dutch . . . . .	lxxxviii
Design for Drapery . . . . .	lxxxix
Decorations for Chair Coverings . . . . .	xc
Batley, Eva A. Illuminated Text for the Nursery . . . . .	300
Bauer, M. A. J. Etching . . . . .	60
Behrens, Prof. Peter. Garden with Open-Air Theater, Mannheim Exhibition . . . . .	193
Beketoff, V. Buffet Cupboard . . . . .	137
Bermann, C. A. Interior and Sculpture . . . . .	194
Beswick, Jessie. Nursery Frieze . . . . .	66
Bezzi, Bartolomeo. Painting . . . . .	247
Billings, Prof. H. Mannheim Exhibition. Vestibule . . . . .	192
Blanche, J. E. Painting . . . . .	128
Boberg, Anna. Painting . . . . .	274
Boberg, Ferdinand	
Antependium . . . . .	60
Exteriors . . . . .	161, 162
Bodley, G. F. Reredos . . . . .	65
Boldini, Giovanni. Painting . . . . .	251
Bone, Muirhead. Sketches in Lead Pencil . . . . .	397
Bookbinding. Tools and Appliances . . . . .	cxx, cxxi, cxxii, cxxiii, cxxiv, cxxv, cxxvi, cxxvii, cxxviii, cxxix
Borglum, Gutzon. Sculpture . . . . .	xciv, xcv
Brahe, Fr. Architect. Garden at Mannheim Exhibition . . . . .	158
Brangwyn, Frank	
Decorative Panels . . . . .	9, 10, 13, 14, 15, 17, 18, 19
Pastel Study . . . . .	11
Briggs, R. A., F.R.I.B.A., Architect. Exterior . . . . .	lxv
Brown, Arnesby. Painting . . . . .	34
Brown, T. Austen. Painting . . . . .	59
Burger, Fritz. Painting . . . . .	236
CAMERON, Miss M. Paintings . . . . .	68, 69
Carr, Mrs. G.	
Brooch, Blotting-Book Cover . . . . .	227
Enamel Picture . . . . .	228
Carter, F. Book Illustration . . . . .	303
Chapman, Gertrude M. Design for a Lace Fan . . . . .	300
Chapple, John. Book Cover . . . . .	297
Charlton, W. H. Pencil and Chalk Drawings . . . . .	182, 183, 185, 186, 187, 188
Cimiotti, Gustav, Jr. Painting . . . . .	xl
Clarenbach, Max. Painting . . . . .	328
Clausen, George, A.R.A. Painting . . . . .	45
Clay Working . . . . .	lxvi, lxvii, lxviii, lxix, lxx, lxxi, lxxii
Coburn, Alvin Langdon. Photographs . . . . .	207, 209
Cooper, Lydia. Panels of Enamel Boxes . . . . .	226, 227
Cope, A. S., A.R.A. Portrait . . . . .	31
Corot, J. B. C. Painting . . . . .	145
Cottet, Charles. Painting . . . . .	244
Couse, E. Irving. Painting . . . . .	82
Cowper, F. Cadogan. Paintings . . . . .	61
Cox, Kenyon	
Mural Decorations . . . . .	ii, iii, iv, v, vii
Paintings . . . . .	vi, viii, ix, xii, xiii
Cartoon for Stained Glass . . . . .	xi
Czajkowski, S. Painting . . . . .	126
DARNAUT, Hugo. Painting . . . . .	153
Daubigny, C. F. Painting . . . . .	147
Davis, Charles H. Painting . . . . .	xlvi
Draper, Herbert. Paintings . . . . .	47
Drury, Alfred, A.R.A. Sculpture . . . . .	32
Dyer, William B. Photographs . . . . .	205, 214
EAST, Alfred. Paintings . . . . .	36, 54
Edmiston, T. M. Photograph . . . . .	214
Embury, Aymar. Architect	
Palisade's Trust and Guaranty Company. Entrance . . . . .	ciii
Bracket . . . . .	civ
Lamp Standard . . . . .	civ
Sketch . . . . .	cv
Public Space . . . . .	cvi
Exterior and Plan . . . . .	cvii

## Index

	PAGE
Embury, Aymar. Detail of Screen . . . . .	cviii
Endell, Aug., Architect. Interiors . . . . .	323
Essex County Court House, Newark, N. J. Mural Decorations . . . . .	ii, xiv, xvi
FALAT, Julian. Painting . . . . .	116
Falkenberg, Architect. Antependium . . . . .	80
Forbes, Stanford A., A.R.A. Painting . . . . .	48
Frampton, George, R.A.	
Sculpture . . . . .	33, 229
Badge . . . . .	140
Froehlich, Mrs. Hugo	
Scarab . . . . .	xci
Fob, Chains, Pins . . . . .	xci, xcii, xciii
Brooch and Rings . . . . .	xcii
Pins and Links . . . . .	xciii
GILBERT, Cass. Architect. Interior of the Essex County Court House . . . . .	xv
Gillot, Louis. Paintings . . . . .	105, 106, 107, 108, 109
Gilsoul, Victor. Painting . . . . .	329
Gioli, Francesco. Painting . . . . .	277
Glasby, William. Stained Glass Windows . . . . .	64
Gornik, Friedrich. Sculpture . . . . .	317, 318, 319
Gould. Patio . . . . .	lvi, lvii
Grenander, Prof. A. Interiors . . . . .	232, 233, 234, 235
Guaccimanni, Vittorio	
Paintings . . . . .	163, 164
Chalk Drawing . . . . .	165
Gurschner, Gustav. Medallion Portraits . . . . .	314
HACKER, Arthur, A.R.A. Painting . . . . .	43
Hallström, Gunnar. Hanging . . . . .	79
Haney, James Parton. Sketches in Design . cxxxv, cxxxvi, cxxxvii, cxxxviii, cxxxix, cxl, cxli, cxlii, cxliii, cxliv	
Harrison, Alexander. Painting . . . . .	xcviii
Hassam, Childe. Painting . . . . .	xlii
Hellwag, Prof. R. Painting . . . . .	189
Hemy, C. Napier, A.R.A. Painting . . . . .	46
Hengeler, A. Painting . . . . .	327
Henri, Robert. Painting . . . . .	li
Hepburn, Hugh. Design for an Illuminated Page . . . . .	301
Heu, Josef. Sculpture . . . . .	148
Hölzel, A. Painting . . . . .	237
Hornel, E. A. Paintings . . . . .	2, 3, 4, 5, 6, 7, 8
Howard, Ebenezer. Plans . . . . .	lxiv
Hubbell, Henry Salem. Painting . . . . .	xlvii
Hudson, Gwynedd. Design for a Panel for Mural Decoration . . . . .	299
INNOCENTI, Camillo. Painting . . . . .	273
Iowa State Capitol. Mural Decorations . . . . .	iii, iv, v, vii
JACK, Richard. Portrait . . . . .	53
Jakitsch, R. Sculpture . . . . .	74, 75
James, George Wharton. "California Missions" . . . . .	xxviii
James, W. F. Photograph . . . . .	200
Japanese Floor Covering. Matting . . . . .	l, lii, liii, liv, lv
Jungnickel, Ludwig	
Stencil Drawings . . . . .	21, 22, 25, 26
Stencil Landscapes . . . . .	23, 27
KALLMORGEN, Friedrich. Paintings . . . . .	157, 190
King, Minnie. Woodcarving Panels . . . . .	65
Klein, Philip. Painting . . . . .	272
Koopman, Augustus. Painting . . . . .	225
Kornhas, Prof. K. Majolica Bust . . . . .	238
Krausz, W. Victor. Portrait . . . . .	154
LARSSON, Carl. Painting . . . . .	276
Laszcka, Konstanly. Sculpture . . . . .	122
Lathrop, W. L. Painting . . . . .	87
La Touche, Gaston. Paintings . . . . .	130, 131, 132, 132
Läuger, Prof. Max. Gardens at Mannheim Exhibition . . . . .	195, 196, 193
Laverock, Florence K. Lithograph Panel . . . . .	67
Lavery, John. Painting . . . . .	275
Lawrence, Frederick K. Photographs . . . . .	210, 213
Lee, J. T. Portion of Altar Rail . . . . .	303
Leitner, R. Sculpture . . . . .	319
Licht, Hans. Painting . . . . .	320
Little, Robert W., R.W.S. Paintings . . . . .	172, 173, 174, 175, 177, 178, 179, 180, 181
Liverpool City School of Art. Wrought Iron Grille . . . . .	67
Llewellyn, W. Painting . . . . .	52
Lockwood, Wilton. Portraits . . . . .	263, 264, 265, 266, 267, 268

## Index

	PAGE
Looschen, Hans. Painting . . . . .	158
Lucas, Seymour, R.A. Painting . . . . .	41
Lytton, Hon. Neville. Drawing and Study in Red Chalk . . . . .	304, 305
MAKAREWICZ, J. Portrait Study . . . . .	123
Malczewski, Jacek. Painting . . . . .	125
Maliutin, S. Carved Door and Frame . . . . .	135
Interior, Exterior of the Talashkino Theatre . . . . .	332, 333
Mann, Harrington. Painting . . . . .	49
"Marie Antoinette" Shawl . . . . .	lxii, lxiii
McEwen, Walter. Painting . . . . .	81
Memphis Bindery. Binding . . . . .	cxxxiv
Menard, E. R. Painting . . . . .	129
Metcalf, Willard L. Painting . . . . .	xliii
Milesi, Alessandro. Portrait . . . . .	270
Milles, Ruth. Sculpture . . . . .	245, 246
Millet, F. D. Paintings . . . . .	cix, cxi, cxii, cxiii, cxiv, cxv, cxvi, cxvii, cxviii, cxix
Minkowski, Maurice. Paintings . . . . .	76, 77
Moira, Gerald. Painting . . . . .	44
Monet and Manet. Illustrations. "History of Modern Painting" . . . . .	xcviii
Monticelli, A. Painting . . . . .	143
Mora, F. Luis. Painting . . . . .	xlix
Moroni, Giovanni. Illustration. "Pictures and Their Painters" . . . . .	c
Mountford, Albert. Majolica Tiles . . . . .	296
Müller-Schoenefeld, Wilhelm. Painting . . . . .	158
Murray, David. Painting . . . . .	40
NEAME, S. Elwin. Photographic Studies . . . . .	312, 313
Newnes Art Library. Illustration, "Fra Angelico" . . . . .	cii
Nomellini, P. Painting . . . . .	273
Norfolk, Constance E. Embroidered Table Center . . . . .	297
Nowak, Anton. Painting . . . . .	243
OLBRICH, Josef. Architect. Exteriors, Interiors . . . . .	215, 216, 217, 218, 219
Ophcy, Walter. Painting . . . . .	237
Orchardson, W. Q., R.A. Portrait . . . . .	42
Orlik, Emil. Stage Mountings . . . . .	220, 221, 222, 223, 224
Orpen, W. Lead Pencil Sketch . . . . .	306
PANKIEWICZ, T. Portrait . . . . .	117
Patterson, Oscar. Leaded Glass Panel . . . . .	70
Penz, Ludwig. Wood Figures . . . . .	239, 240, 243, 245
Petersen, Hans Von. Painting . . . . .	156
Phillips, Mr. Exterior. Patio . . . . .	lvi, lvii
Pollaiuolo, Antonio. Sculpture . . . . .	ci
Potter, Louis. Sculpture . . . . .	xvii, xviii, x.x, xx, xxi, xxii, xxiii, xxiv
Pratt Institute. Lace Making . . . . .	lviii, lix, lx, lxi
Priestman, Mabel Tuke Carpet Loom . . . . .	xxx
Rugs . . . . .	xxx, xxxi, xxxii, xxxiii, xxxiv, xxxv, xxxvi
Pyle, Howard. Mural Decoration . . . . .	xvi
RAEBURN, Sir Henry. Portrait . . . . .	xlv
Renouard, P. Drawings . . . . .	230, 231
Ress, Paul. Painting . . . . .	150
Roerich, N. Settee . . . . .	139
Decorative Friezes . . . . .	331
Rönqvist, Mlle. Lotten. Gobelin . . . . .	78
Rousseau, Th. Painting . . . . .	144
Rubenstein, A. Sculpture . . . . .	317, 318
Rusiñol, Santiago. Paintings . . . . .	98, 99, 100, 101, 102, 103, 104
Ruszczyz, Ferdynand. Interior . . . . .	125
SANDROCK, Leonhard. Painting . . . . .	157
Sargent, John S., R.A. Portrait . . . . .	51
Sartorio, A. Decorative Panel . . . . .	276
Saxton, John Gordon. Painting . . . . .	xlviii
Scattola, Ferruccio. Painting . . . . .	248
Schaefer, Hans. Medallion . . . . .	156
Scharf, Victor. Portrait . . . . .	153
Schmieding, Adolf. Sculpture . . . . .	239
Schneider, Emil. Portrait . . . . .	236
Schönleber, Gustav. Painting . . . . .	326
Schulz, Otto. Pen Drawings . . . . .	324, 325
Selvatico, Ling. Painting . . . . .	248
Shannon, J. J., A.R.A. Painting . . . . .	55
Sheldon-Williams, Inglis. Old China . . . . .	111, 112, 113, 114
Sichuski, Kasimir. Painting . . . . .	118

## Index

	PAGE
Siebert, Interior . . . . .	232
Sigmundt, Ludwig. Painting . . . . .	241
Simandl, Emilie. Sculpture . . . . .	75
Simon, Lucien. Painting . . . . .	127
Sims, Charles. Paintings . . . . .	88, 89, 90, 91, 92, 93, 94, 95, 96, 97
Sintenis, W. Sculpture . . . . .	159, 160, 161
Sjostrom, Maria. Embroidered Cushions . . . . .	81
Skogman, Agnes. Antependium . . . . .	80
Smallbones, Arthur. Woodcarving Panels . . . . .	65
Spencer, Emma. Study . . . . .	199
Spenlove-Spenlove, F. Painting . . . . .	56
Spikeman. Binding for "In Memoriam" . . . . .	cxxxiii
Stockholm, Handarbetets Vanner. Gobelin, Linen Hanging, Hanging, Antependiums, Embroidered Cushions . . . . .	78, 79, 80, 81
Stott, Edward, A.R.A. Painting . . . . .	39
Struys, Alexandre. Paintings . . . . .	284, 285, 286, 287, 288
Stuart, Gilbert. Portrait . . . . .	xli
Sturgis, Russell. Baalbek Temple . . . . .	xxvii
Szczyglinski, Henryk. Painting . . . . .	124
Szymanowski, W. Sculpture . . . . .	126
TARBELL, Edmund C. Paintings lxxiv, lxxvi, lxxvii, lxxviii, lxxix, lxxx, lxxxi, lxxxii, lxxxiii, lxxxiv, lxxxv, lxxxvi	
Tawse, Sybil. Design for a Painted Bowl . . . . .	298
Taylor, L. Campbell. Painting . . . . .	35
Tenishef, M. K. Arm Chair . . . . .	136
Tenishef, Princess. Portion of Embroidered Stole . . . . .	334
Thiem, Paul. Painting . . . . .	321
Thomas, Grosvenor. Paintings . . . . .	256, 257, 258, 259, 260, 261, 262
Thonger, Charles. "Rock and Water Gardens" . . . . .	xxix
Tito, Ettore. Paintings . . . . .	249, 250
Tornai, Gyula. Painting . . . . .	226
Twiggs, Bessie. Clock Case . . . . .	xxvi
UGO, Antonio. Painting . . . . .	278
Unwin, F. Mabelie. Pastel and Painting . . . . .	308, 313
VAN DE VELDE, H. Interiors . . . . .	71, 72, 73
Velasquez. Illustration, "Pictures and Their Painters" . . . . .	xcix
Venice Exhibition. Interiors . . . . .	269, 270, 271
Villa, Hernando G. Design for Stained Glass . . . . .	xxv
Von Mehoffer, Josef. Paintings, Window . . . . .	115, 118, 123
WACKERLE, J. Nymphenburg Porcelain . . . . .	322
Walker, Henry Oliver. Mural Decoration . . . . .	xiv
Walcott, W. Drawings . . . . .	308, 309, 311
Walton, George, Architect. Exteriors, Interior, Plan, Heading for Note-Paper . . . . .	62, 63
Warlow, Hilda. Panel for Screen . . . . .	66
Wastberg, Mlle. Carin. Linen Hanging . . . . .	79
Waterhouse, Alfred, R. A. Sketches . . . . .	279, 281, 283
Waterhouse, J. W., R.A. Study . . . . .	37
Watson-Schütze, Eva. Photographs . . . . .	201, 203
Westendorf, Fritz. Painting . . . . .	238
White, Clarence H. Photographs . . . . .	204, 206
Wibberley, H. Woodcarving Panels . . . . .	65
Wiggins, Carleton. Painting . . . . .	xxxviii
Willard, S. L. Photographs . . . . .	211, 212
Williamson, William S. Portion of a Music Cabinet . . . . .	302
Wise, Henry T. Interior . . . . .	70
Withers, Alfred. Painting . . . . .	58
Withers, Isobel Dods. Painting . . . . .	58
Worcester Art Museum. Exterior . . . . .	xxxix
Y. W. C. A., New York. Work in Modeling . . . . .	xxvi
ZETSCHKE, Eduard. Painting . . . . .	152
Zinovief, A. Arm Chair . . . . .	136
Wooden Frame . . . . .	136
Wall Brackets . . . . .	137, 139
Carved and Painted Casket . . . . .	138
Wall Cupboard . . . . .	138
Table . . . . .	331

## COLOUR INSERTS

ADIE, Edith Helena. "Herbaceous Border at Knole, Kent." A Colored Reproduction of the Oil Painting . . . . .	141
AXENTOWICZ, Theodore. "A Ruthenian Peasant Girl." A Colored Reproduction of the Painting . . . . .	119
BORGLUM, Gutzon, Sculptor. A Tinted Reproduction of the Portrait of John William Mackay . . . . .	xcv



# Index

	PAGE
BRANGWYN, Frank, A.R.A.	
"Venetian Serenaders." A Colored Reproduction of the Pastel Study . . . . .	11
A Tinted Reproduction of Sketches for Venetian Panels . . . . .	15
CHARLTON, W. H. "Canal Scene, Quimperle." A Colored Reproduction of the Chalk Drawing . . . . .	183
COBURN, Alvin Langdon. "The Duck Pond." A Tinted Reproduction of the Photograph . . . . .	207
COROT, J. B. C. "The Quiet River." A Colored Reproduction of the Painting . . . . .	145
COX, Kenyon	
"The Beneficence of the Law." A Tinted Reproduction of the Mural Decoration . . . . .	ii
"Augustus Saint Gaudens." A Tinted Reproduction of the Painting . . . . .	ix
GILLOT, Louis. "Le Depart du Train de Marine." A Colored Reproduction of the Oil Painting . . . . .	109
GILSOUL, Victor. "Old Embankment at Bruges." A Colored Reproduction of the Painting . . . . .	320
HORNEL, E. A. "What's O'Clock." A Colored Reproduction of the Oil Painting . . . . .	2
JUNGNIKEL, Ludwig. A Colored Reproduction of Two Stencil Landscapes . . . . .	22, 27
LITTLE, Robert, R.W.S.	
"Moonlight at Florence." A Colored Reproduction of the Water-Color Drawing . . . . .	172
"On the Banks of the Tiber." A Tinted Reproduction of the Water-Color Drawing . . . . .	175
METCALF, Willard L. "Kalmia." A Tinted Reproduction of the Painting . . . . .	xlili
MILLET, F. D. "Wandering Thoughts." A Tinted Reproduction of the Painting . . . . .	cix
SGMUNDT, Ludwig. "The Old Town." A Colored Reproduction of the Oil Painting . . . . .	241
SIMS, Charles. "Sunshine and Wind." A Colored Reproduction of the Oil Painting . . . . .	88
SPIKEMAN. A Tinted Reproduction of Binding for "In Memoriam" . . . . .	cxxxiii
TARBELL, Edmund C. "The Venetian Blind." A Tinted Reproduction of the Painting . . . . .	lxxiv
THOMAS, Grosvenor. "Cluden Mill." A Colored Reproduction of the Oil Painting . . . . .	256
WALCOTT, W. "Chapel of Henry VII, Westminster Abbey." A Colored Reproduction of the Water-Color Drawing . . . . .	309
WATERHOUSE, Alfred, R. A. "Santa Maria Degli Angeli, Rome." "Interior of Cathedral, San Remo." Colored Reproductions of two Water-Color Sketches . . . . .	279, 281
WATERHOUSE, J. W., R.A. "Phyllis and Demophoon." A Tinted Reproduction of the Sketch . . . . .	37
WATSON-SCHUTZE, Eva. "Girl's Head." A Tinted Reproduction from the Photograph . . . . .	201
WIGGINS, Carleton. "The Leader of the Herd." A Tinted Reproduction of the Painting . . . . .	xxxviii

## BOOKS REVIEWED

<i>Alfred Stevens et son Œuvre.</i> By Camille Lemonnier . . . . .	83
<i>Annuaire General et International de la Photographie.</i> By M. Roger Aubry . . . . .	337
<i>Anthony Van Dyck.</i> By Lionel Cust . . . . .	ci
<i>Antonio Pollaiuolo.</i> By Maud Cruttwell . . . . .	xcix
<i>Art and Craft of Garden Making.</i> By Thomas H. Mawson . . . . .	168
<i>Art and the Camera.</i> By Anthony Guest . . . . .	337
<i>Art of the Dresden Gallery.</i> By Julia de Wolf Addison . . . . .	ci
<i>Art of the Greeks.</i> By H. B. Walters . . . . .	334
<i>Artist's Blue Book of Chicago.</i> By S. R. Winchell . . . . .	ci
<i>Attraverso gli Albi e le Cartelle.</i> By Vittorio Pica . . . . .	169
<i>Brasses of England.</i> By Herbert W. Macklin, M.A. . . . .	168
<i>Brothers Maris.</i> By Croal Thompson . . . . .	c
<i>Byron, Poems of.</i> By Mr. Charles Whibley. Illustrations by A. S. Forrest . . . . .	253
<i>Canada.</i> Painted by T. Mower Martin. Described by Wilfrid Campbell . . . . .	335
<i>Catalogue of the George A. Hearn Gift to the Metropolitan Museum.</i> . . . .	cii
<i>Chaffer's Handbook to Hall Marks on Gold and Silver Plate.</i> By Christopher A. Markham . . . . .	253
<i>Cities of Spain.</i> By Edward Hutton . . . . .	84
<i>College of St. Mary de Winton, or New College.</i> By Edmund Hort New . . . . .	169
<i>Color of London: Historical, Personal and Local.</i> By W. J. Loftie, F.S.A. . . . .	83
<i>Correggio.</i> By T. Sturge Moore . . . . .	xcix
<i>Dante and His Italy.</i> By Lonsdale Ragg . . . . .	169
<i>Das Bildnis im Achtzehnten und Neunzehnten Jahrhundert.</i> By Dr. Julius Leisching . . . . .	252
<i>Discoveries in Crete, and Their Bearing on the History of Ancient Civilization.</i> By Ronald M. Burrows . . . . .	252
<i>Eighteenth Century Prints.</i> By Julia Frankau . . . . .	169
<i>Escorial.</i> By Albert F. Calvert . . . . .	ci
<i>Essentials in Architecture.</i> By John Belcher . . . . .	335
<i>Flachenschmuck in Character der Dresdener Schule.</i> Von Oskar Haebler . . . . .	85
<i>Fra Angelico.</i> By Edgcombe Staley . . . . .	xcix
<i>French Furniture.</i> By André Saglio . . . . .	252
<i>Gewandstudien für Kunst und Kunstgewerbe.</i> By H. Friling . . . . .	xxviii
<i>Giovanni Bellini.</i> By Everard Meynell . . . . .	xcix
<i>Goya.</i> By Dr. Muther . . . . .	c
<i>Guide to the Paintings in the Florentine Galleries.</i> By Maud Cruttwell . . . . .	169
<i>History of Architecture.</i> By Dr. Russell Sturgis . . . . .	xxvii
<i>History of Modern Painting.</i> By Professor Richard Muther . . . . .	167, xcvii
<i>History of Painting.</i> By Richard Muther . . . . .	334

## Index

	PAGE
<i>History of Scottish Seals.</i> By Dr. de Gray Birch . . . . .	337
<i>History of Scottish Seals.</i> By Walter De Gray-Birch, LL.D., F.S.A. . . . .	84
<i>Horse: A Pictorial Guide to Its Anatomy.</i> By Professors Wallenberger and H. Baum. Translated by Professor Sisson . . . . .	253
<i>House Decoration.</i> By Paul N. Hasluck . . . . .	xxix
<i>House Hints.</i> C. E. Schermerhorn . . . . .	xxix
<i>In and Out of the Old Missions of California.</i> By George Wharton James . . . . .	xxvii
<i>Internationale Bibliographie der Kunstwissenschaft.</i> By Arthur L. Jellinek . . . . .	253
<i>Inventaire General des Dessins du Musee du Louvre et du Musee de Versailles</i> . . . . .	85
<i>Keats, Poems of.</i> Arthur Symons. Illustrations by Mr. Edmund Sullivan . . . . .	253
<i>Later Work of Titian.</i> By Henry Miles . . . . .	xcix
<i>Life of William Blake.</i> By Alexander Gilchrist . . . . .	84
<i>Murillo.</i> By Albert F. Calvert . . . . .	ci
<i>Old English Furniture of the Seventeenth and Eighteenth Centuries.</i> By Mr. G. Owen Wheeler . . . . .	253
<i>Old Engravers of England.</i> By Malcolm C. Salaman . . . . .	336
<i>On Art and Artists.</i> By Max Nordau . . . . .	83
<i>Outskirts of the Great City.</i> By A. G. Bell . . . . .	336
<i>Petit Trianon, Versailles.</i> By James A. Arnott and John Wilson, Architects . . . . .	252
<i>Pictures and Their Painters.</i> By Mrs. L. M. Bryant . . . . .	xcviii
<i>Pierre Puget: Decorateur et Mariniste.</i> By Philippe Auquier . . . . .	335
<i>Poems by William Wordsworth.</i> Selected with introduction by Stofford A. Brooke. Illustrations by Edmund H. New . . . . .	85
<i>Poets' Country.</i> By Andrew Lang. Illustrated by Francis S. Walker . . . . .	250
<i>Practical Pencil Work.</i> By Mr. Scott Mitchell . . . . .	252
<i>Pre-Raphaelite Brotherhood.</i> By T. Ernest Pythian . . . . .	xcix
<i>Report on the Noyes Collection of Japanese Prints, Drawings, etc.</i> Librarian of Congress . . . . .	cii
<i>Rock and Water Gardens.</i> By Charles Thonger . . . . .	xxix
<i>Roman Sculpture from Augustus to Constantine.</i> By Mrs. Arthur Strong . . . . .	85
<i>Romantic Cities of Provence.</i> By Mona Caird. Illustrated by Joseph Pennell and Edward M. Synge . . . . .	85
<i>Scenes in the Life of Our Lord.</i> Drawn by Harold Copping. Described by Handley C. G. Moule . . . . .	336
<i>Seville, an Historical and Descriptive Account of the Pearl of Andalusia.</i> By Albert F. Calvert . . . . .	cii
<i>Sir William Beechey.</i> By W. Roberts . . . . .	85, c
<i>Studies in Pictures.</i> By John C. Van Dyke . . . . .	252
<i>Talbot J. Taylor Collection</i> . . . . .	xxvii
<i>Te Tohunga: The Ancient Legends and Traditions of the Maoris.</i> By W. Dittmer . . . . .	251
<i>Three Vagabonds in Friesland with a Yacht and a Camera.</i> By H. F. Tomalin. Photographic Pictures by Arthur Marshall . . . . .	251
<i>Useful Details in Several Styles.</i> By Herbert E. Binstead . . . . .	xxviii
<i>Venice.</i> By Beryl de Selincourt and May Sturge Henderson . . . . .	167
<i>Whistler.</i> By Dr. H. W. Singer . . . . .	c
<i>Whistler Notes and Footnotes and Other Memoranda.</i> By A. E. Gallatin . . . . .	c
<i>Wild Flowers of the British Isles.</i> By H. Isabel Adams, F.L.S. . . . .	167
<i>William Blake. Vol. I.</i> With introduction by Laurence Binyon . . . . .	337
<i>Wood Engraving and Placard Cutting.</i> By Charles E. Dawson . . . . .	253
<i>Year Book of Photography and Amateur's Guide for 1907-8.</i> By F. J. Mortimer . . . . .	337





# The INTERNATIONAL • STUDIO •

Reg. U. S. Pat. Off.



*Copyright, 1900, by Kenyon Cox  
From a Copley Print, Copyright, 1900, by Curtis & Cameron, Publishers, Boston*

**JOHN LANE COMPANY**  
110-114 West Thirty Second Street  
• NEW YORK •

‡ Monthly • 50 cts. ‡  
Yearly Subscription \$ 5<sup>00</sup> Post paid

## Art Students' League of New York



### SUMMER SCHOOLS

Out-of-door classes in Landscape Painting under

**MR. BIRGE HARRISON**

at Woodstock, Ulster County, New York, from June 1st to October 1st.

The City Summer School will consist of classes in Drawing, Painting, Illustration, Composition, and Commercial Design under

**MR. THOMAS FOGARTY and  
MR. WALTER WALZ FAWCETT**

in the American Fine Arts Building, 215 West 57th Street, from June 3rd to September 21st.

Circulars on Application to

The Art Students' League of New York  
215 West Fifty-seventh Street, - New York, N. Y.

# HIGGINS'

DRAWING INKS  
ETERNAL WRITING INK  
ENGROSSING INK  
TAURINE MUCILAGE  
PHOTO MOUNTER  
DRAWING BOARD PASTE  
LIQUID PASTE  
OFFICE PASTE  
VEGETABLE GLUE, etc



Are the Finest and Best Inks and Adhesives

Emancipate yourself from the use of corrosive and ill-smelling inks and adhesives and adopt the Higgins Inks and Adhesives. They will be a revelation to you, they are so sweet, clean and well put up

At Dealers Generally

**CHAS. M. HIGGINS & CO., Mfrs.**  
Branches: Chicago, London

271 Ninth Street Brooklyn, N. Y.

## New York School of Applied Design for Women

**200 WEST 23d STREET**

(Incorporated 1892)

SPECIAL LIFE CLASS. ALSO SPECIAL COURSE IN  
DESIGN UNDER ALPHONSE MUCHA

Silk and Wall Paper Designing, Antique  
and Costume Sketch Classes, Historic  
Ornament, Architecture.

Apply to **HELEN LOOMIS, Secretary**

## BACK NUMBERS

**THE (ENGLISH) STUDIO**  
Vols. I to IX inclusive. Handsome Uniform  
Cloth Binding Complete, \$100.00 net.

**THE INTERNATIONAL STUDIO**  
Vols. I—XXVII inclusive. Being Complete  
File of Bound Volumes to February, 1906,  
inclusive, \$100.00 net.

**ADDITIONAL BOUND VOLUMES**  
Vols. XXVIII, XXIX, XXX. To Complete  
File up to February, 1907, inclusive, \$3.00  
net per volume.

SEND YOUR BACK NUMBERS  
to the Publishers for Binding in Permanent  
Volume Form.

Cloth Binding, Uniform with Series, \$1.00  
per volume.

BEST WORKMANSHIP. MOST REASONABLE RATES

**JOHN LANE COMPANY**

110-114 WEST THIRTY-SECOND ST., NEW YORK

MR.

# WILLIAM M. CHASE

writes us as follows

"I am better pleased  
with your colors, af-  
ter a thorough test,  
than any other  
colors I have used"

Write for booklet "Ullman's  
Manual of Artists' Colors"

**SIGMUND ULLMAN  
C O M P A N Y**

Park Ave. & 146th St., N.Y.

# TIFFANY & CO.

Fifth Avenue and 37th Street, New York

## Loving Cups

A large assortment of sterling silver loving cups in Tiffany & Co.'s exclusive designs, not sold by the trade or through other dealers

English Sterling Quality, 925/1000 fine

4½ inches high, 3 handles	-	-	-	-	-	-	-	\$18
5 " " 2 "	-	-	-	-	-	-	-	24
6 " " 3 "	-	-	-	-	-	-	-	38
Others	-	-	-	-	-	-	-	\$45, \$70, \$85 upward

Special drawings, upon short notice, of prizes suitable for coaching parades, motor boat races, tennis, golf, etc.

## Bowls

for fruit, salads, berries, etc. Sterling silver with rich relief work in substantial weights

9 inches diameter	-	-	-	-	-	-	-	\$20
10½ " "	-	-	-	-	-	-	-	28
11½ " "	-	-	-	-	-	-	-	36
12½ " "	-	-	-	-	-	-	-	50

*Photographs sent upon request*

## Comparison of Prices

Tiffany & Co. always welcome a comparison of prices. This applies to their entire stock of rich as well as inexpensive jewelry, silverware, watches, clocks, bronzes, and other objects, on all of which their prices are as reasonable as is consistent with the standard of quality maintained by the house

## Tiffany & Co. 1907 Blue Book

A compact catalogue without illustrations—621 pages of concise descriptions with an alphabetical side index affording quick access to the wide range of Tiffany & Co.'s stock, with the minimum and maximum prices at which articles may be purchased.—Blue Book sent upon request

# Fifth Avenue New York

# BUILD RIGHT

If you would know how to do this, read

## The Architectural Record

*The National Architectural Monthly*

No matter in what kind of a building you are interested, from an inexpensive bungalow to a residence costing millions, or a gigantic warehouse, you will find something in this magazine to interest you.

We will send a sample copy to any reader of THE INTERNATIONAL STUDIO.

---

---

THE ARCHITECTURAL RECORD CO., New York

# *The* AMERICAN ARCHITECT AND BUILDING NEWS

A Weekly Journal of Constructive and Decorative Art. Now in its Eighty-ninth Volume.

A sample copy will be sent on request to readers of the International Studio

We shall be pleased to send also a price list of books published by us and an illustrated catalogue of the most complete and important work on colonial architecture that has ever appeared—"THE GEORGIAN PERIOD."

THE AMERICAN ARCHITECT (INC.)

Kimbel Building,

12 West 40th Street,

New York City



# HOUSE DECORATION & FURNISHINGS

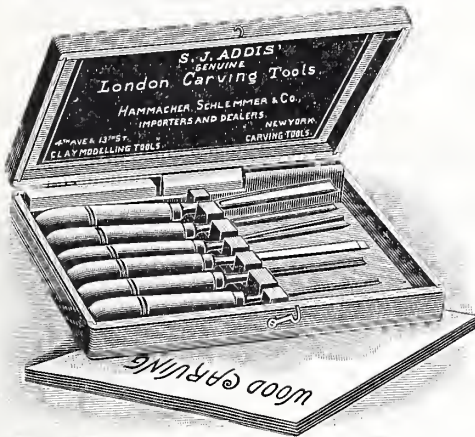

## WOOD CARVERS' TOOLS

THE GENUINE S. J. ADDIS. LONDON MAKE

Recognized by experts the world over to be the finest quality made

Send for Catalogue No. 2219, Entitled "Wood Carvers' Tools and Accessories"

**HAMMACHER, SCHLEMMER & CO.**  
HARDWARE, TOOLS and SUPPLIES  
NEW YORK, SINCE 1848  
4th Ave. and 13th St.



## Long Sang Ti & Co. IMPORTERS

307 FIFTH AVENUE, Near 31st St.  
NEW YORK

Genuine Chinese and Japanese  
Objects of Art

Real Chinese Jade & Oriental Jewelry  
*Write for Illustrated Booklet A*



## Misses Whittredge & Barrows

*Interior Decoration*

*General Decorative Work & Designing*

4 WEST 40th STREET, NEW YORK CITY



## THE UNIVERSITY PRINTS

1,500 subjects on Greek and Italian art. Size  $5\frac{1}{2} \times 8$  inches. One cent each or eighty cents per hundred. *Send for Catalogue.*

Dutch, Flemish and German Series in preparation.

Bureau of University Travel, 16 Trinity Place, Boston, Mass.

*In writing to advertisers, please mention The International Studio*

## "Gewandstudien"

Studies of Flowing Draperies  
(on Female Figures)

ORIGINAL DRAWINGS BY H. FRILING

For the use of Artists, Illustrators, Designers, Glass Workers, Painters and others. Suggestions for Poster Work and Figural Compositions. 16 plates, in heliotype, containing over 40 illustrations. In portfolio, \$6.00.

## BRUNO HESSLING CO., Ltd.

64 East 12th Street, New York, N. Y.

**VOUGA CELEBRATED FINE ART STUDIES**  
Latest complete illustrated Catalogue, 30c. New Flower, Fruit, Figure, Landscape and Animal Studies—suitable for Oils and Water Colors. Discounts given in Catalogue.  
M. G. PRICE, 359 West 118th St., New York

## We Purchase Designs For Photographic Backgrounds

Good opportunity for artists having  
new ideas in this direction  
*WRITE FOR PARTICULARS*

**ROBEY-FRENCH COMPANY**  
34 Bromfield Street, Boston, Mass., U. S. A.

## The Country Cottage

BY G. L. MORRIS AND ESTHER WOOD

16mo, cloth, \$1.00 net; leather, \$1.25 net. Post. 5c.

*The Country Gentleman* says:

"An interesting little book, beautifully illustrated, has 73 half-tones, showing many different styles of cottages, with plans for building them. Unlike many books of this kind, it is written in an interesting way that quite inspires one with the wish to build a cottage like some of those described."

Other volumes in the Country Handbook Series include Sailing, Kennel and Fisherman's handbooks, etc. Send for list.

**JOHN LANE COMPANY, 110-114 W. 32d St., New York**

# GARDEN AND LAWN FURNISHINGS

## METAL GARDEN ORNAMENTS

### Lawn and Park Fountains

Aquaria, Drinking Fountains, Flower  
Vases, Statuary, Settees and  
Chairs, Sun Dials

CATALOGUES ON APPLICATION

Address: ORNAMENTAL DEPT.



Copyright, 1903, by The J. L. Mott Iron Works.

**THE J. L. MOTT IRON WORKS, Fifth Avenue and 17th Street, New York**



## SUN DIALS

with or without PEDESTALS

Send for illustrated Price List K

Hartmann Bros. Mfg. Co.

New York Office, 1123 Broadway

Mount Vernon, N. Y.

## ROCK *and* WATER GARDENS

By **CHARLES THONGER**

Author of "The Book of Garden Furniture,"  
"The Book of Garden Design," etc.

LATEST ISSUE IN THE HANDBOOKS  
OF PRACTICAL GARDENING SERIES

12mo. Illustrated. \$1.00 net. Postage, 6c.

### CHAPTERS

ROCK GARDEN CONSTRUCTION  
ROCK GARDEN IN SPRING  
ROCK GARDEN PLANTS  
ROCK GARDEN SHRUBS  
WILD WATER MARGINS  
SMALL WATER GARDENS  
BOG AND MARSH GARDENS  
LILY TANKS  
WATER LILIES  
AQUATICS AND BOG PLANTS  
ROCK AND ALPINE GARDENS

**JOHN LANE COMPANY**

110-114 West 32d Street, NEW YORK

## THE STABLE

### HANDBOOK

By T. F. DALE

Full Particulars for the  
Guidance of Owners of  
Moderate Means.

With 32 Half-Tone  
Illustrations of the Best  
Types of Hunter, Thoroughbred, Hackney, Trotter,  
Harness Horse, Pony, Brood Mare, etc. To-  
gether with 10 Plans Showing Skeleton, Parts of  
Foot, Legs, Teeth, etc.

16mo. \$1.00 net. Postage 6c.



### CHAPTERS

**THE STABLE**

**FORAGE**

**HUNTERS**

**THE HARNESS HORSE**

**HORSES AT GRASS**

**SIMPLE REMEDIES, etc.**

"Everything in the book," says the author,  
"is the result of the personal experience of  
one who has always loved horses and had to  
consider ways and means. I have tried to put  
down only what I have proved to be useful,  
and to consider what counsels would have been  
most profitable to myself as a beginner in the  
practice of horsemanship."

**JOHN LANE COMPANY**

110-114 West 32d Street, NEW YORK

SAINT LOUIS

PHILADELPHIA

BALTIMORE

We are the

# Oldest Manufacturers, Importers and Dealers in Artists' Materials, Draughtsmen's and Engineers' Supplies

Established 1854. Recommended by Prominent Artists.

F.W. & Co.'s finest prepared Oil and Moist Water Colors, Canvases (for oil and pastel color painting), Soft and Half-hard Pastels, Pastel Papers and Boards, Water-proof Drawing Inks.

Artists' finest Red Sable, Russian Sable, Bristle, Ox-Hair and Camel Hair Brushes.

Photo Retouching Tints

— Red No. 1, Brown No. 2, Black No. 3. In tubes, size 2 x 1/2 inches, each 25c.

Blanc D'Argent and Photo White. The only Whites that will stand the test.

Air Brushes, Air Brush Materials. F.W. & Co.'s Air Brush Lamp Black in tubes. All of F.W. & Co.'s moist Water Colors are used in the Air Brush.

China Paints and China Painters' Materials.

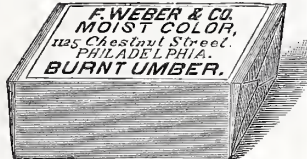

Harbutt's Plasticine. A new composition Clay. Read what the leading Sculptors say about it. Modelling Tools, all shapes, all sizes, all kinds.

Materials for Illustrators, Designers, Fresco Painters, Sculptors, Textile Workers, Engravers and Lithographers.

Blue Process Papers, Detail and Tracing Papers, Drawing Papers, T-Squares, Triangles, etc., etc.

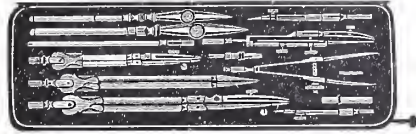

Sole Agents for Riefler's Round System Instruments.

Works on Art for Illustrators, Fresco Painters, Sculptors, Engravers, Textile Workers and Lithographers.

Write for Complete Catalogue, Vol. 263

F. WEBER & Co., 1125 Chestnut Street, Philadelphia, Pa.

Branch Houses: ST. LOUIS, 709 Locust St. BALTIMORE, 227 Park Ave.

"THE MOST COMPLETE AND VALUABLE WORK EVER ISSUED ON ANY CRAFT."

## PLAIN—PLASTERING—DECORATIVE

A PRACTICAL TREATISE ON THE ART AND CRAFT OF PLASTERING AND MODELLING  
New Revised Edition. By WILLIAM MILLAR, Plasterer and Modeller

Illustrated by Fifty-five Full-Page Plates, and Five Hundred smaller Illustrations in the Text

Large 4to (11 ins. by 8 1/2 ins.), containing 630 pages, strongly bound in canvas. \$7.50 net (Express Extra)

Some topics treated in this unique and indispensable book:

### HISTORY OF PLASTER WORK

#### MATERIALS:

Plaster of Paris, Lime, Mastic, Hair, Cements of all descriptions, with a complete account of

#### PORTLAND CEMENT

#### DECORATIVE CEILINGS

#### MOULDINGS: RUNNING, DIMINISHED AND CIRCULAR

#### EXTERIOR PLASTERING:

Instructions for making Facades in Portland Cement and in Colors, Fresco. Fresco Secco, etc.

#### MODELLING:

Basic Principles. Proportions of Human Body. Tools for Clay Working. Modelling in Cement, Wax, Tow, etc.

#### MOULDING AND CASTING:

How to Make Moulds, cast in Plaster, Wax, etc., etc.

#### GELATINE MOULDING

#### FIBROUS PLASTER WORK

#### COMPOSITIONS:

Papier Maché, Stage Properties. Carton Pierre. Sulphur Moulds.

#### GISSO:

Method of Preparation and Application.

#### GISSO DURO

#### GISSO GROSSO

#### GISSO SOTTILE

Method of Making and Manipulating. Full Recipes for Mixing, etc., etc.

#### SCAGLIOLA

#### FOREIGN PLASTER WORK:

Saracenic, Persian, Spanish, Moorish, Indian, Chinese, Italian, French, German, Austrian, Belgian, Russian, English, Scotch, Irish.

#### TERRA COTTA

#### PLAIN CONCRETE

#### REINFORCED CONCRETE:

Concrete and Iron, Concrete and Wood, Steel Concrete.

#### CONCRETE GARDEN FURNITURE

#### ARCHITECTURE

Elements applied to Plaster Work.

#### TOOLS AND APPLIANCES

JOHN LANE COMPANY, 110-114 West 32d Street, NEW YORK

In writing to advertisers, please mention The International Studio.

AD. V

# Artists' Materials

LEFRANC & CIE; P. FOINET FILS,  
BLOCKX



## Oil Colors

And all the  
Prominent  
Makes

## Canvas

A Special Feature

## "Plasteline"

For Sculptors

### A. C. FRIEDRICHS

169 W. 57th St., New York

Largest Retail Artists' Material Dealer in the U. S.

Catalogue Free

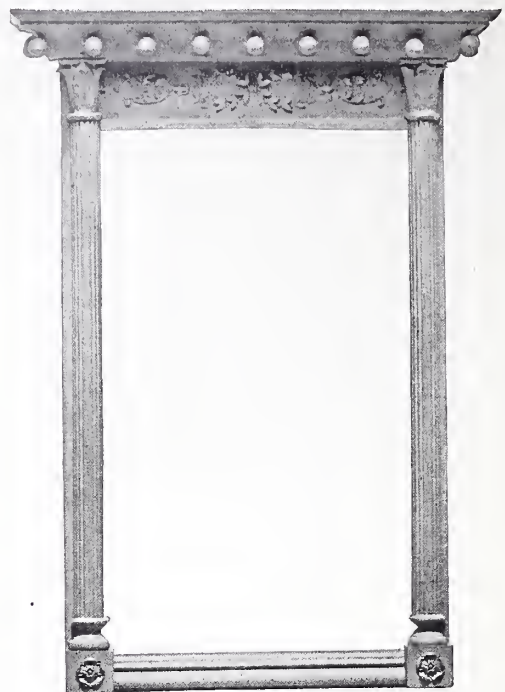

No. 1007

### COLONIAL MIRRORS OF ALL PERIODS

*Illustrated Catalogue Free*

**FOSTER BROTHERS, 4 Park Square, Boston**

## THE SPANISH SERIES

Edited by ALBERT F. CALVERT. A New and Important Series of Volumes dealing with Spain in its various aspects—Its History its Art, its Cities, its Monuments. *Per volume, 12mo, \$1.25 net. Postage, 10 cents extra.*



### MURILLO

A Biography and Appreciation. Illustrated by over 165 Reproductions from Photographs of his most Celebrated Pictures.

### THE PRADO

A Guide and Handbook to the Royal Picture Gallery of Madrid. Illustrated with 220 Reproductions from Photographs of Old Masters.

### THE ESCORIAL

A Historical and Descriptive Account of the Spanish Royal Palace, Monastery and Mausoleum. Illustrated with Plans and 278 Reproductions from Pictures and Photographs.

*In Preparation.*

SEVILLE

SPANISH ARMS AND ARMOR

CORDOVA



## MOORISH REMAINS IN SPAIN

Vol. I. CORDOVA, SEVILLE AND TOLEDO

By ALBERT F. CALVERT. 80 Colored Plates. 200 Black-and-White Illustrations and 200 Diagrams. \$15.00 net. *Express, 50 cents.*



The Conquest of Spain by the Moors, and a detailed account of the Architecture and Decoration of Cordova, Seville and Toledo. The distinctive beauties of Moorish art are emphasized by the 80 colored plates reproduced in this volume.

Vol. II. THE ALHAMBRA OF GRANADA

By ALBERT F. CALVERT. 80 colored Plates and 300 Black-and-White Illustrations. *Large 8vo. \$15.00 net. Express, 50 cents.*

A brief history of the Moslem rule in Spain from the reign of Mohammed the First to the final expulsion of the Moors, together with a particular account of the construction, the architecture and the decoration of the Moorish Palace.

**JOHN LANE COMPANY, 110-114 WEST 32d STREET, NEW YORK**

*In writing to advertisers, please mention The International Studio.*

AD. VI

# The International Studio

Copyright, 1907, by John Lane Company

---

## CONTENTS, JULY, 1907

---

THE WORK OF KENYON COX. By Minna C. Smith. Ten Illustrations . . .	iii
THE ESSEX COUNTY COURT HOUSE. Three Illustrations . . . . .	xiv
LOUIS POTTER'S BRONZE GROUPS OF ALASKAN INDIANS. Eight Illustrations .	xvii
SCHOOL NOTES. Three Illustrations . . . . .	xxiv
RECENT PUBLICATIONS IN ARCHITECTURE AND DECORATION. Three Illustrations . . . . .	xxvii
WEAVING IN A HAND LOOM. By Mabel Tuke Priestman. Nine Illustrations. .	xxx
EUROPEAN SECTION:	
MR. E. A. HORNEL'S PAINTINGS OF CHILDREN AND FLOWERS. By E. Rimbault Dibdin. Seven Illustrations . . . . .	3
THE VENICE EXHIBITION: MR. BRANGWYN'S DECORATIVE PANELS IN THE BRITISH SECTION. By A. S. Covey. Eleven Illustrations . . . . .	9
THE COLORED STENCIL DRAWINGS OF LUDWIG JUNGNICHEL. Eight Illustrations	21
THE ROYAL ACADEMY EXHIBITION, 1907. Nineteen Illustrations . . . . .	29
THE TWENTIETH SUMMER EXHIBITION OF THE NEW GALLERY. Ten Illustrations . . . . .	50
REVIEWS AND NOTICES . . . . .	83
THE LAY FIGURE: On the Study of Color . . . . .	86
STUDIO TALK:	
(From our own Correspondents)	
LONDON. Twelve Illus. . . . .	60
LIVERPOOL. Four Illus. . . . .	66
EDINBURGH. Three Illus. . . . .	68
GLASGOW. Two Illus. . . . .	69
DUBLIN . . . . .	70
WEIMAR. Four Illus. . . . .	71
PARIS . . . . .	73
BERLIN. . . . .	74
VIENNA. Four Illus. . . . .	74
WARSAW. Two Illus. . . . .	76
MANNHEIM . . . . .	77
STOCKHOLM. Eight Illus. . . . .	78
MELBOURNE . . . . .	80
ATLANTA, GEORGIA. Three Illus. . . . .	81

### COLOR INSERTS:

- A Tinted Reproduction of the Mural Decoration by Kenyon Cox, entitled, "The Beneficence of the Law."
- A Tinted Reproduction of the Painting by Kenyon Cox, entitled "Augustus Saint Gaudens."
- A Colored Reproduction of an Oil Painting by E. A. Hornel, entitled, "What's O'Clock?"
- A Colored Reproduction of a Pastel Study for "Venetian Serenaders," by Frank Brangwyn, A.R.A.
- Tinted Reproductions of Sketches for Venetian Panels, by Frank Brangwyn, A.R.A.
- Colored Reproductions of two Stencil Landscapes, by Ludwig Jungnickel.
- A Tinted Reproduction of a Sketch for Phyllis ("Phyllis and Demophon"), by J. W. Waterhouse, R.A.

---

**CHANGE OF ADDRESS** *Subscribers desiring to register change of address must notify the publishers on or before the 10th of the month. Please be sure to give FORMER ADDRESS also.*

## Art Tuition

### The New York School of Art

2237-2239 BROADWAY, NEW YORK CITY

SUMMER TERM

SUMMER CLASSES IN THE CITY, May 15 to Sept. 8, 1907

Instructors—ERNEST LAWSON, KENETH HAYES MILLER  
FRANK ALVAH PARSONS, GRACE D. LYNN

Daily Classes—Life, Portraiture, Still Life, Illustration, Composition and Design. Open Air Classes under Ernest Lawson.

EUROPEAN SUMMER CLASS

HOLLAND, BELGIUM, FRANCE AND ITALY

Instructors—ROBERT HENRI, DOUGLAS JOHN CONNAH

Leaving New York June 15th and June 25th, the latter date for the convenience of teachers of art. Special rates for those not studying. For rates and further particulars address

DOUGLAS JOHN CONNAH, President

### SUMMER SCHOOL OF PAINTING

VINEYARD HAVEN, MASS.  
(Island of Martha's Vineyard)

Conducted by

ARTHUR R. FREEDLANDER

THIRD SEASON, JUNE 15th—SEPT. 15th

Outdoor Classes: Landscape, marine, figure. Three criticisms per week. Special course for Students of Architecture to develop facility in the handling of color.

For prospectus, address A. R. FREEDLANDER, 80 W. 46th St., New York.

### School of Industrial Art OF THE PENNSYLVANIA MUSEUM

BROAD AND PINE STREETS, PHILADELPHIA

Thorough work under trained specialists  
in all branches of Fine & Industrial Art

Special provision for classes in Illustration, Architecture, Decorative Painting, and Sculpture, Pottery, Metal Work, Industrial Design, Textile Design and Manufacture.

L. W. MILLER, Principal

MISS EMILIE C. ADAMS  
MINIATURES

Portraits and Figures on Porcelain and Ivory. Decorative work in both Mineral Painting and Water Color

Studios: 745 Third Ave., Lansburgh, N. Y.  
and at the Emma Willard Art School, Troy, N. Y.

## Art Tuition

SEVENTH SEASON 1907

### Alexander Robinson's Classes

Specialty: MODERN WATER COLORS; Pure, scrubbed, gouache and tempera; OILS, PASTEL, notes and finished work, and all branches black and white.

Sketching from Nature, Composition and all stages of work from the "Sketch" to the "Picture." Demonstrations before the class. Class in VENICE up to June 1st.

June and July - - BRUGES

Aug., Sept. and Oct., HOLLAND

Moderate terms. For full information and entries apply

The ALEXANDER ROBINSON SCHOOL  
Headquarters, Bruges, Belgium

### Art Academy of Cincinnati

SUMMER TERM, 1907

JUNE 17 TO AUGUST 24

Drawing and Painting from Life  
Composition, Anatomy, Wood Carving  
China Painting, Design

Located in Eden Park, overlooking the city.

The Art Museum and its Library are open free.

J. H. GEST, Director, Cincinnati

Fall Term opens September 23.

### The London School of Art

Stratford Road, Kensington, W., London, England

Drawing, Painting, Composition, Illustration, Etching

Teaching Staff { JOHN M. SWAN, R. A.  
FRANK BRANGWYN, A. R. A.  
G. SPENCER WATSON  
ARTHUR S. COVEY

SUMMER CLASS IN LUXEMBOURG

Membership is limited in all classes and students will be admitted in the order of their application whenever a vacancy occurs.

For further particulars, apply to

C. P. TOWNSLEY, Director

## ART STUDENTS

The Publishers of THE INTERNATIONAL STUDIO make the following special offer to Art Students

### THREE MONTHS TRIAL SUBSCRIPTION FOR ONE DOLLAR

THE INTERNATIONAL STUDIO is the Standard Art Magazine. It records and reflects with authoritative articles by skilled critics and with an unsurpassed abundance and quality of illustrations in color, tint, black and white, and line, all the important art movements of the day in this country and in Europe. It does not pretend to be a student's magazine in the sense of concerning itself more or less exclusively with student affairs. It is simply the indispensable periodical for those art students who are genuinely in earnest and care to keep in touch with the work being done by the leading artists of the day. So valuable has it become that a subscription to it is considered by educators to be a liberal course in art study.

"ART IS LONG"—WELL CHOSEN READING IS A LONG STEP FORWARD

THE MAGAZINE SPEAKS FOR ITSELF. TRY IT

# Art Tuition

## ART SCHOOL

*Awarded International Silver Medal at St. Louis, 1904*

Term: October 1—June 1. For Beginners and Advanced Students.

Design, Modeling, Wood-carving,  
Cast and Life Drawing,  
Water-Color and Painting;  
Evening Class in Costume Drawing.

Instructors:

SOPHIA ANTOINETTE WALKER, HELEN M. TURNER

Young Women's Christian Association,

7 East 15th St., New York.

Office Hours: 9 A.M. to 5 P.M. and 7 to 9 P.M.

A THOROUGHLY MODERN

## School of Arts and Handicrafts

Finely Equipped Shops and Expert Instruction in METAL WORKING, BOOKBINDING, WOOD CARVING, MODELING, LEATHER WORKING, POTTERY.

Three Year Courses in Fine Art, Decorative Art, Normal Art, Architecture.

Four Free Scholarships Awarded Yearly. Cash Prizes. For illustrated circular, address

THEO. HANFORD POND, Supt.

Department of Fine Arts

MECHANICS INSTITUTE,

ROCHESTER, N. Y.

## THE MISSES MASON

Studio: 48 East 26th Street, New York

Classes in

Design, Decoration of Porcelain

Catalogue on Request

## COLUMBUS ART SCHOOL

Excellent facilities for the study of Drawing, Painting, Modeling, Design and Illustration. 28th year begins Oct. 1st, 1906.

Columbus, Ohio

JOHN E. HUSSEY, Director

## New York School of Industrial Art

343 WEST 57TH ST: A PROFESSIONAL SCHOOL of DESIGN

Architecture, Interior Decoration; Textile, Costume & Commercial Design; Art Crafts. Teachers of these Subjects Thoroughly Trained.

ELISA A. SARGENT, President.

In writing to advertisers, please mention *The International Studio*.

# Art Tuition

## WRITERS



We sell Stories, Poems, Jokes, Illustrations, Designs and all Publishable Material on Commission

If you can produce salable work we know who wants it and who will pay best prices for it. We can save you time and money in the disposal of your Productions by our careful system. Our plan is explained in our booklet "Cash Returns," sent to any address for four cents.

THE BURELL SYNDICATE, 770 Brunswick Bldg., N. Y. City



## ARTISTS

## TEACHERS COLLEGE

COLUMBIA UNIVERSITY, NEW YORK

OFFERS 185 Courses of Instruction, including the Theory and Practice of Teaching Art—Principles of Design—Drawing, Painting and Illustration—Clay Modeling—Design in Construction and Decoration—Interior Decoration—the History and Appreciation of Art.

Announcement for 1907-8 Now Ready

ARTHUR V. DOW, Director, Department of Fine Arts

JAMES E. RUSSELL, LL.D., Dean

## The Art Institute ART SCHOOL of Chicago

W. M. R. French, Director N. H. Carpenter, Secretary

Study art under the most favorable conditions in this country—in the Art Institute with its art galleries, permanent collections, passing exhibitions, lecture courses, libraries, and constant association with accomplished artists and teachers.

Drawing, Painting, Illustrating, Normal Instruction, Sculpture, Decorative Design and Architecture. Students may enter at any time. No art student, east or west, ought to select his school until he has seen the fine illustrated catalogue of the Art Institute, mailed free on application.

Be careful of the name, the Art Institute.

RALPH HOLMES, Registrar

Dept. P., Art Institute

CHICAGO, ILL.

## Los Angeles School of Art and Design INC. EST. 1887

Every branch in Drawing, Painting, Illustrating; under artist exhibitors in the chief galleries of the world. Illustrated prospectus. L. E. G. MACLEOD, Director, Los Angeles, Cal.

## OUT-DOOR SKETCHING CLASS

Point Pleasant, New Jersey.

From June 1st till October 1st

Out-door figure study a specialty. Pupils can work in any medium.

Address for full particulars. MISS ROSALIE PALMIÉ

Point Pleasant, N. J.

AD. IX

# WANTED

## Note to Subscribers

*THE Publishers of the INTERNATIONAL STUDIO will buy in copies of the following issues in good condition. These issues having become rare will be bought at 50 cents a copy, though issued at the old rate (35 cents.)*

1899

January, February, October  
November, December

1900

January

1903

March, December

1904

January, June, August, October

*The Publishers offer this advanced rate to complete sets with the above numbers which have been in special demand. If you have any such copies which you do not need, address*

JOHN LANE COMPANY, 110-114 W. 32d St., New York

# PLASTER CASTS



## Special Reduced Prices

Antique, Mediæval  
and Modern Statuary.  
Suitable for the  
Decoration of Halls,  
Living-Rooms, Dens,  
Libraries and Studios.

Decorative and  
Architectural Casts  
for Schools, Colleges,  
Libraries, Art Classes.

*"The eye must be trained. We cannot know history without going to the records. We can never know Art unless we accustom the eye to the beauty of form."*

For Full Particulars of this Special Offer Address:

**INTERNATIONAL STUDIO**

JOHN LANE CO., 110-114 W. Thirty-Second St., New York

# PICTURES AND THEIR PAINTERS

By LORINDA MUNSON BRYANT

Crown 8vo.

\$3.50 net.

Postage, 25 cents

## A POPULAR HISTORY OF THE GREAT PICTURES OF THE WORLD AND THEIR PAINTERS



POPE JULIUS II. By Raphael. Uffizi, Florence

*Profusely Illustrated with over 300 choice reproductions*

## INVALUABLE TO ART CLASSES AND LIBRARIES

*The exceptional opportunities that the author, a practical art teacher of wide experience, has had in studying the original paintings of artists in the galleries of Europe and her thorough preparation make her book of special value to the student, while her own keen appreciation of the need of a comprehensive and interesting history of painting for the class-room and home stamps "Pictures and Their Painters" as the art teacher's most timely friend and the home-keeper's delightful companion.*

**JOHN LANE COMPANY**

110-114 West Thirty-Second Street, New York

*In writing to advertisers, please mention The International Studio.*

AD. X



# ARTISTS' MATERIALS

## F.W. Devoe & Co.'s

### Artists' Tube Colors

CANVAS, ACADEMY BOARDS,  
FINE BRUSHES FOR OIL AND  
WATER-COLOR PAINTING, etc.

"THE STANDARD QUALITY"

*Everything in Artists' Materials*

## F.W. DEVOE & C.T. RAYNOLDS CO.

Fulton Street, cor. William  
NEW YORK

176 Randolph Street  
CHICAGO

The Largest Manufacturers and Importers of Artists' Materials  
in the United States

## WM. H. POWELL

Fine Art Gallery, 983 6th Ave., New York

### ARTISTS' MATERIALS

New York Agent for. LEFEBVRE-FOINET and  
EDOUARD of Paris

And BLOCKX'S HAND-GROUND, PERMANENT BEL-  
GIAN OIL COLORS and AMBER VARNISH, BEST IN  
THE WORLD, French Canvas and Brushes. Mail Orders have  
prompt attention.

PICTURE FRAMING A SPECIALTY

A WONDERFUL INVENTION!

## ALGUMAR WATER COLORS

BLEND LIKE OIL. DO NOT RUN

Picture upright. No waiting for washes  
to dry. Full instructions free

A. G. Marshall, Thousand Island Park, N. Y.

## OPYROPEN

Leading Instrument in Pyrography. Heated by GAS. No Benzine  
or Bellows. All Art Material Dealers, or post-paid for \$1.00 from  
WISEMAN MFG. CO., 147 W. 26th Street, New York

In writing to advertisers, please mention *The International Studio*.

## A. Sartorius & Co.

Manufacturers and Importers of

### Artists' Colors and Materials

#### China Colors in Powder

(In vials or In bulk.) Vials and corks for dealers and teachers  
bottling china colors.

#### China Colors in Tubes

(Oil and Water Preparation.)

#### Artists' Oil Colors, Artists' Water Colors, Artists' Moist Oleo Colors, Artists' Fine Brushes

Write for A. Sartorius & Co.'s Catalogue containing many  
instructions how to mix and apply colors.

45 Murray Street, New York

## S

## PENCERIAN STEEL PENS

never make any "breaks." They  
won't spit, sputter or dig holes in  
your paper. Every Spencorian  
Pen is accurately and carefully made.  
Every one a sleek, easy writer. Points  
always even, smooth, accurately ground.

Try them. Send six cents for postage  
and a sample card of 12 pens, all different  
styles, will be sent you.

SPENCERIAN PEN COMPANY,  
649 BROADWAY, NEW YORK

## DRAWING PENCIL PERFECTION

IN ELEVEN GRADES OF HARDNESS

Send 16 cents for generous samples of  
Dixon's American Graphite Artists' Pencils

JOSEPH DIXON CRUCIBLE CO., Jersey City, N. J.

AD. XI

# The Richmond Player Piano



## No Discordant Note

**J**UST as the discord hurts the trained ear of the musician, so does the false note in decoration hurt the eye of the lover of the beautiful. If your living-room is to contain a piano and is to have Mission furniture, it should by all means be a Richmond Mission Player Piano. With the satisfying musical qualities that are attained only in Richmond Piano construction, this self-playing instrument is distinguished by the extreme simplicity of its player mechanism, its quick and sympathetic response and ease of control. Its standard tracker-board gives access to all music catalogues except one.

Price \$700 (freight and handling additional)

## THE STARR PIANO COMPANY

General Factors for the Richmond Piano Co.

FACTORY AND EXECUTIVE OFFICES

RICHMOND, INDIANA

*Handsome Catalogue in color on request without cost*

### FACTORY SALESROOMS:

Cincinnati, Ohio, 139 West Fourth Street  
Cleveland, Ohio, 736-38 Euclid Avenue  
Dayton, Ohio, 4th and Ludlow  
Detroit, Mich., Valpey Building, 213-17 Woodward Avenue  
Indianapolis, Ind., 138-40 Pennsylvania Street  
Los Angeles, Cal., 413 West Fifth Street  
Richmond, Indiana, 931-35 Main Street  
Toledo, Ohio, 329 Superior Street

### JESSE FRENCH P. & O. CO.

Birmingham, Alabama, 2018 Second Avenue  
Chattanooga, Tennessee, 626 Market Street  
Dallas, Texas, 286 Elm Street  
Montgomery, Alabama, 108-12 Dexter Avenue  
Nashville, Tennessee, 240-42 Fifth Avenue, N.  
St. Louis, Missouri, 1114 Olive Street

SELLING AGENTS IN ALL CITIES





Copyright, 1906, by Kenyon Cox  
Copyright, 1907, by De W. C. Ward

“UNDER THE RULE OF LAW  
INSPIRED BY JUSTICE  
PEACE AND PROSPERITY ABIDE”

MURAL PAINTING BY KENYON COX  
FOR THE ESSEX COUNTY COURT HOUSE  
NEWARK, NEW JERSEY

# The INTERNATIONAL STUDIO

Copyright, 1907, by John Lane Company

THE WORK OF KENYON COX  
BY MINNA C. SMITH

AT THE beginning of this year the latest and, in certain respects, the best products of the genius and training of Kenyon Cox in mural art were placed in the Iowa State House at Des Moines and in the new Essex County Court House at Newark, N. J.

*The Progress of Civilization* is well placed in the Capitol of Iowa, a State which boasts an average of educated citizens higher than that of many States of the Union, a typical American commonwealth. This composition shows freedom and power, richness and variety of color, mastery of line, spontaneity and joy in conception. It takes first rank, so far in his career, in the work of Mr. Cox, who for the past two years has been enabled by the growing

demand in America for decoration of buildings, both public and private, to devote all of his time to mural painting. This increase of opportunity for decorative painting is due partly to the insistence of modern architects upon this form of beauty and partly to an awakened culture in men of civic committees east and west. There is also rivalry for beauty in buildings like the Citizens' Bank at Cleveland, or the Manhattan Hotel in New York, each of which possesses one of the eight important murals that Mr. Cox has painted.

The Newark picture, *The Beneficence of Law*, has an appealing delicacy and depth of color and much dignity of composition. Its elevation of conception, too, entitles this picture to important rank in consideration of the work of this artist. It is admirably placed in the Court House. As it is a single picture about nine feet by twelve feet, and



Copyright, 1905, by Kenyon Cox. Copyright, 1906, by De W. C. Ward

“HERDING” DECORATION FOR IOWA STATE CAPITOL

BY KENYON COX



Copyright, 1906, by Kenyon Cox  
Copyright, 1906, by De W. C. Ward

“SCIENCE”  
DECORATION FOR IOWA STATE CAPITOL  
BY KENYON COX



Copyright, 1906, by Kenyon Cox  
Copyright, 1906, by De W. C. Ward

"THE FORGE"  
DECORATION FOR IOWA STATE CAPITOL  
BY KENYON COX

## Kenyon Cox



From a Copley Print, Copyright, 1899, by Curtis & Cameron, Publishers, Boston

SCIENCE INSTRUCTING INDUSTRY

BY KENYON COX

with its base only about three feet from the floor, no Veronesian muscular effort of looking up is necessary in its permanent place. The full title painted beneath the picture is *Under the Rule of Law Inspired by Justice, Peace and Prosperity Abide*. There is effective differentiation in the four female figures of the composition. Justice is the heavenly figure, bearing the scales, the only one whose feet are not upon the earth. She is genuinely ethereal in line and poise, and the sky colors of her blue and white drapery are realized with their full poetry. Law is crowned and sceptered, robed in royal red, the central figure. Peace, at her side, with olive branch in her hand, wears colors of the dove and of the rose. The freedom and joy in color of the whole picture are emphatic in the figure of Prosperity. This figure shows unquestionably that mastery for which the artist struggled during the long years in which he was practically the only man in New York who painted the nude as Europeans have painted it, for its beauty, from the days of Michaelangelo to those of Puvis de Chavannes. Figure and face are painted with a conquering beauty and dignity. The head of Prosperity is crowned with a wreath of grain and poppies; the half-nude figure has golden drapery across the knees, and a lap full of fruit; she is offering grapes to a little naked child, one of three sympa-

thetically modelled infants; a second is reaching for fruit, a third is sitting and picking daisies, paying attention to nothing else.

While the Newark picture occupies but a single space, the Des Moines work is composed of eight lunettes. These, showing *The Progress of Civilization*, are placed in eight of twelve equal arches thirty feet from the floor in the rotunda of the State House. The importance of open arches is accented by placing a single large nine-foot figure in each lunette, which backs against and, as it were, buttresses the

open arch; each pair of figures, therefore, establishes a garlanded curve and the entire series makes a true rhythm of line about the rotunda. This composition, as a whole, shows its author's power as a nationalist and a naturalist in art no less than his righteous deference to the established canons and traditions of mural art. Realism in scenes and backgrounds is sparingly employed, and with success, these backgrounds giving added space and air to the rotunda and moving the observer with the sense of beauty localized. The color in the lunettes is intense and varied. Reds are most frequent, gold, purple and dark blue are next in repetition, while the blue and white of the sky and vivid landscape greens carried through the series are unifying notes in the general harmony. There is distinct Western feeling in the scenes of *Hunting*, *Herding* and *Agriculture*, where Ceres with her sickle surveys a harvested field of Indian corn in the "shocks," shaped like Indian tepees. *Herding* is no less Western in scene, and in North American type of manhood, yet is also strictly classical in the figure and in allusion to the pastoral life. The virile herdsman on a hillside pasture, with gray hat and dull red cloak, but little hiding his strong figure, looks off to the distance, where the animals he herds are looking, also, in sudden interest. All are before a background of trees and a





DESIGNED BY  
KENYON COX

*Copyright, 1906, by Kenyon Cox  
Copyright, 1906, by De W. C. Ward*

**"AGRICULTURE"  
DECORATION FOR IOWA STATE CAPITOL  
BY KENYON COX**

## Kenyon Cox

cloud-drifted Iowan blue sky. Four male and four female figures are in *The Progress of Civilization*, the *Forge* and *Science*—which might well be called *Thought*—and the other two masculine figures. The first is a superb nude seated before a rude forge, studying a working drawing fastened to a board. Science, seated in draperies of a queer moonlight gray, is on the parapet of a house. A glowing planet and the lamp of truth illumine the thinker and the terrestrial globe and the books of study; one of these is a strong red, to tie the quiet-toned lunette to the brilliant color in *Art*, the companion lunette. *Commerce* is least successful of the individual figures in the series; although good in color, the figure is a trifle strained in attitude; the idea of putting a heavy burden on the back of the study, *Genius of Transportation*, is not happy. *Education* is a Madonna-like mother teaching a fair-bodied man-child. *Art*, draped in gold and crimson, wearing a golden wreath with symbols of all the arts about her, and with living laurel growing in a clump near her feet, the closing figure of the series, is a partially draped

virginal figure, holding aloft a mirror to reflect the light of the sky.

*The Contemplative Genius of the East* in the Capitol at St. Paul, Minn., and *The Sources of Wealth*, at Cleveland, mural pictures preceding the works which have just been considered, show much of the mastery which Kenyon Cox has now attained. Earlier paintings in this field are *The Reign of Law* in the Appellate Court at Madison Square, New York City; *Venice*, at Bowdoin College, and the well-known decorative pictures at the Library of Congress at Washington. There the architect stood firm as the architects of the Boston Public Library did for mural art as an inherent element of the beauty of an important building.

It is twenty years since, in the illustrations for "The Blessed Damosel" of Rosetti in an edition de luxe, now to be found only in collections, Kenyon Cox first showed that feeling and manner of the mural painter which is found in most of his subsequent work, popularly in illustration, poetically in ideal pictures, practically in portraits and his few landscapes. His famous early *Portrait of Augustus*



Copyright, 1887, by The Century Company

"FLYING SHADOWS"

Courtesy of The Century Company

BY KENYON COX



AUGUSTUS SAINT GAUDENS  
1887  
BY KENYON COX



*Saint Gaudens*, unfortunately lost a few years ago in the fire at the sculptor's studio in New England, near the summer home of the painter, showed the interpretative and pictorial qualities of an artist destined to find full expression in mural painting no less than qualities to be expected in a well-painted portrait. The first and last love of a mural painter, the element of space and design on which he lays most stress, is in Mr. Cox's portrait of the sculptor. Technically, it was the problem of white on whites, the white of plaster in the relief portrait of William Chase on which Saint Gaudens is at work, and the white of whitewashed walls behind the white shirt of the sculptor. There was much imaginative sympathy in the portrait, more than the grace of the head and figure, and that accord between subject and painter which is always of interest to a perceptive amateur, denied as it is by certain artists and also certain writers on art, who put brush work both before and after this subtle element in the success of a portrait. Mr. Chase has within a year or two become possessed of *The Harp Player*, seen at the National Academy and other exhibitions, that painters contemporary with Mr. Cox have been accustomed to consider his best painting. This studio interior, a realistic, truthful work, evidently inspired by Dutch masters, is interesting, as it shows the training Mr. Cox gave himself for the work of his life, now assured in the maturity of his powers

Another sort of training is shown in the landscape *Flying Shadows*, which belongs to the estate of the late Stanford White. There is a breadth and sweep in this landscape which is wide, in the manner of those Velasquez chose for backgrounds. But these shadows are evanescent above soft-bosomed Ohio hills, instead of stern Spanish heights and plain. In all of Mr. Cox's earlier easel pictures and in the innumerable illustrations for the magazines, by which he lived for years, he was preparing both unconsciously and consciously to take his rank among the three or four Americans who are our acknowledged leaders in the art of mural painting.

The story of his development as an artist is, broadly, the story of the development of art in this country during the past thirty years. When he began to work with brush and palette as a boy of fifteen in Ohio, no very good pictures of any sort had yet been painted by an American born beyond the Allegheny Mountains and no mural painting worthy of the name existed on this side of the Atlantic. But the boy came of aspiring stock, that has made for civilization in the advance guard of America westward. His father was General Jacob



"COURAGE" BY KENYON COX  
CARTOON FOR CHURCH WINDOW  
OBERLIN, OHIO

## Kenyon Cox

Dolson Cox, of Civil War fame, twenty-third Governor of Ohio; his mother a daughter of President Finney, of Oberlin College, famous as a religious and educational pioneer. The boy dreamed his dreams of following the art of Michaelangelo, a healthful ideal for a youth in what was still the fresh, unhampered West, alive with power to dream and with force to work to make dreams come true. Before his first decorative painting was placed in one of the domes of the Liberal Arts Building in the vanishing "White City" of 1893, there had passed years of study in every avenue of painting. At first the study was in Cincinnati and in Philadelphia. Then after the great awakening art year of 1876, the young man went to Paris, where for five years of his first twenties he studied under Gerome and Carolus Duran. It was on his salon picture of

those days, *A Lady in Black*, that he was elected to the Society of American Artists before he came to New York. A young artist of to-day would scarcely win for such a picture the laurels with which she cheered her painter's path. Although Mr. Cox painted a good many portraits, first and last he was never what may be called a professional portrait painter, and he sold fewer easel pictures than one might believe. His energies were in illustrative work; his fidelity to tasks like getting effects of rich and varied color out of the two colors to which he was restrained in making certain magazine covers. His fidelity of invention in these and others, his constant vital interest in rhythm and balance of line, are rewarded in his present mastery of his chosen medium of expression, from which much may well be expected in future for the enrichment of American art.

To the period since the Columbian Fair belongs the noble *Science Instructing Industry* and *Hope and Memory*, which, with the delightful *Surprise D'Amour*, is in the collection of Mr. J. D. Cox, at Cleveland. *Hope and Memory*, possibly of higher quality than any easel picture by Mr. Cox, has a violet color scheme contrasted with a light golden green. When the ideal picture was exhibited at the National Academy in the days when the old crimson wall coverings prevailed at exhibition, it was killed, practically, in the clash of its color with that of its background. It was painted to hang against a soft rose-colored wall, where its color has the advantage which its poetry of line and symbol deserve.

*The Hunting Nymph*, of the type of *The Eclogue*, a well-known exhibition study of the nude, is an interesting canvas, the property of the Lotos Club, New York, of which Mr. Cox is a life member. The variety of his talent is shown in *Courage*, designed for glass for a memorial window in a church in Oberlin; in a more important window at Pittsburg; in such sculptural decoration as those he designed for the University Club, New York; for the seal of the Boston Public Library; for the bronze modelled by Augustus Lukeman, for a coat-of-arms above a fireplace in the Richards Memorial Library at Warrensburg, N.Y. He has published two books, one for children, and a volume of art criticism, "Old Masters and New." The foreword in that book may well be repeated as Kenyon Cox's creed in verse, his poetical confession of his working faith:

"Work thou for pleasure, paint or sing or carve  
The thing thou lovest, though the body starve.  
Who works for glory misses of the goal;  
Who works for money coins his very soul.  
Work thou for work's sake, then, and it may be  
That these things shall be added unto thee."



Copyright, 1900, by Kenyon Cox  
From a Copley Print, Copyright, 1900, by  
Curtis & Cameron, Publishers, Boston

HOPE AND MEMORY

BY KENYON COX



*Owned by National Academy of Design  
Hung in the Academy's Spring Exhibition*

PORTRAIT OF  
CASS GILBERT, A.N.A.  
BY KENYON COX

## The Essex County Court House



POWER AND BENEFICENCE  
FOR ESSEX COUNTY COURT HOUSE

BY HENRY OLIVER WALKER

### THE ESSEX COUNTY COURT HOUSE

THE new building of the Essex County Court House in Newark, N. J., for which Mr. Kenyon Cox painted the decoration reproduced on a foregoing page, is the work of Mr. Cass Gilbert, the architect of the St. Paul Capitol, the New York Custom House and other recent buildings of note. The portrait of Mr. Gilbert, painted by Mr. Cox, was shown at the recent exhibition of the National Academy, the architect having been elected an associate of that body.

The new Court House is not yet finished. In a later issue of the magazine we shall have occasion to present in fuller scope the achievements of the architect and artists engaged upon it. A glimpse of the interior is shown in illustration. The pendentives seen in this view have been decorated by Edwin Howland Blashfield. Through the doorway in the rear is seen the Criminal Court Room, where the decoration by Henry Oliver Walker is in place. This painting, entitled *Beneficence and Power*, is reproduced above. The painting is not low in tone, but the darker photograph shows the composition to better effect. The colors denote a

moment just before sunrise, with red and yellow light striking up into the sky. The idea expressed in the subject is the driving away of evil and the uplifting of the fallen. The decorative quality of the work, which keeps it an integral part of the room which it adorns, is admirably sustained.

Another interesting painting is Mr. Howard Pyle's decoration for the room of the Board of Freeholders. The subject is historical, being the landing of Caratret in Jersey, and the treatment is more pictorial. The first Governor of the Province, Captain Philip Cartaret, is seen at the moment of his coming ashore at Elizabethport in August, 1665. His ship, the "Philip," lies at anchor in the distance. His secretary is in the act of reading to the assembled colonists his credentials as Governor. Native onlookers sit on the ground near by, complacent but wondering. Behind Cartaret is a companion who has borne him company on his mission and is evidently interested in the odd sights of the New World.

The fourth figure of the central group is the master of the ship. Beyond the trumpeter and the soldiers stand thirty immigrants from the Island of Jersey, who sailed on the "Philip" for a hazard of new fortunes.





ESSEX COUNTY COURT HOUSE  
CASS GILBERT, ARCHITECT



Copyright, 1906, by Howard Pyle

THE LANDING OF CARTARET  
BY HOWARD PYLE  
FOR ESSEX COUNTY COURT HOUSE

LOUIS POTTER'S BRONZE GROUPS OF ALASKAN INDIANS

IN 1899 Mr. Louis Potter made a roving expedition to Tunis in the north of Africa, where the characteristics of the native life and character caught his eye with notable results. His interesting series of Tunisian statuettes has now been succeeded by a series of studies of the Alaskan Indian. These figures, several of which are here reproduced, and which have been cast in bronze by the Gorham Company, are not founded on a hasty acquaintance, for the sculptor has lived with these people, listened to their own story of their history and traditions, and taken part in their daily occupations, joining the hunters in the chase and the fishermen in their rude canoes. Hardly less interesting are the types of American prospector intruding his enterprise into the older order.

It should be said that these Thlinket Indians, comprising about a dozen tribes along the coast of Southeastern Alaska, are in no way related to the Esquimaux or the Aleuts. Physically they are short in stature, sturdy and vigorous. Mentally they show no little poetry of imagination in their myths. Their religion seems originally to have been a form of nature worship, in which the universal spirit took many forms, including such phe-

nomena as the wind, as well as birds and beasts and reptiles.

In the *Taku Wind*, Mr. Potter has conveyed the spirit of an odd legend, by which the natives explain the presence of the glacier, which is known to us as the Muir. Two young girls, according to the legend, occupying a hut in the neighborhood, found after washing their clothes that it was impossible to dry them. They rashly invoked the spirit of the North Wind, which impatiently overdid the thing and froze the streams. The ice, so formed, was a swiftly moving danger. It was reduced to its present immobility, for the Indians believe that the glacier now stands stock-still, by the sacrifice of the foolish virgins, who were thrown into its then dangerous path.

*The Spirit of the Night* symbolizes the personification of the long winter night, which plays an important part in the lives of Alaskans. Being quite innocent of all controversy over nature stories, they delight in attributing natural results to unverified causes. Darkness, light, heat, cold, flood and drought are the work of kindly or ill-disposed spirits, the "Yekh" of the air, of the land and of the sea.

The conical hat worn by the old man in the group of *Clam Diggers* is a characteristic detail, pointing by its shape to the supposed ethnic relationship with

Mongolian peoples and emphasizing the native aptitude in this sort of weaving, a department of arts and crafts which is in a flourishing state among the Thlinkets. Their baskets are said to be hardly rivaled by any others, unless those of the Japanese, from whom the handicraft may have descended. The material used is either a coarse, tough grass, or some form of vegetable fiber, such as the finer roots of the yellow cedar. Two methods of weaving are followed: the "twining," in which the strands are twined around one another, and the "coiling," in which the fibers are coiled around a framework of stiff but fine rods.



BASKET-WEAVERS

BY LOUIS POTTER



THE PROSPECTOR  
BY LOUIS POTTER



A HUNTER AND HIS DOGS  
BY LOUIS POTTER



CLAM-DIGGERS  
BY LOUIS POTTER



SALMON FISHERS  
BY LOUIS POTTER



THE TAKU QUEEN  
BY LOUIS POTTER



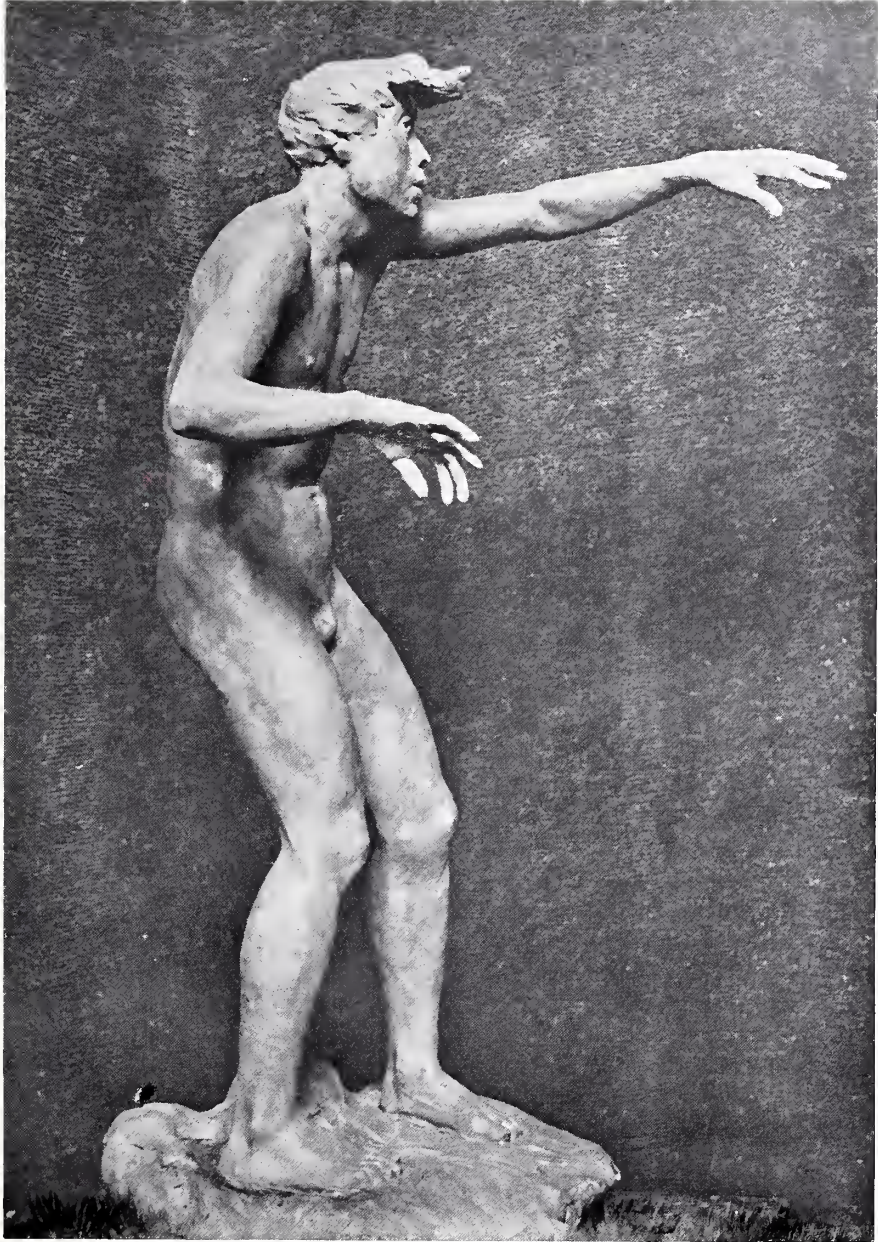

THE SPIRIT OF THE TAKU WIND  
BY LOUIS POTTER

## School Notes



SPIRIT OF THE NIGHT

BY LOUIS POTTER

### SCHOOL NOTES

THE RHODE ISLAND SCHOOL OF DESIGN is conducting classes in outdoor sketching and illustration, weaving, Colonial architecture, machine design, metal work and theory of design and composition.

THE ARTS AND CRAFTS DEPARTMENT of the Washington (D. C.) School of Decorative Industrial and Fine Arts will offer courses next October under the direction of Mrs. Belle Barnett Vesey, president for the past three years of the National

League of Mineral Painters.

THE PENNSYLVANIA MUSEUM AND SCHOOL OF INDUSTRIAL ART, L. W. Miller, Principal, has just held an interesting exhibition of the work of students of its schools of textile and applied art.

TEACHERS COLLEGE, New York, is conducting 185 courses, including theory and practice of teaching art, principles of design, drawing, painting and illustration, clay modeling, interior decoration, etc.

THE SUMMER TERM of the Art Academy of Cincinnati, under the direction of J. H. Gest, extends to August 24.

THE NEWARK (N. J.) PUBLIC DRAWING SCHOOL made an interesting showing in craftwork, a new department of which we shall have more to say in a later issue.

SUMMER CLASSES in the Luxembourg have been arranged by the London School of Art.

THE MISSES MASON, New York City, some of whose recent work was illustrated last month, are holding classes in the decoration of porcelain.

THE BADGER SUMMER SCHOOL of pottery at Madison, Wis., models its instruction on the Alfred pottery methods.

OUTDOOR CLASSES, under Birge Harrison at Woodstock, N. Y., to October 1, and classes in the city under Thomas Fogarty and Walter Walz Fawcett to September 21, are conducted by the Art Students' League, New York.

## School Notes

THE STATE NORMAL SCHOOL OF COLORADO at Greeley, Col., has been producing, under the direction of R. Ernesti, some noteworthy pottery, which will shortly be treated at greater length.

THE NEW YORK SCHOOL OF ART conducts summer classes under Ernest Lawson, Kenneth Hayes Miller, Frank Alvah Parsons and Grace D. Lynn, to September 8.

THE LOS ANGELES, CAL., SCHOOL OF ART AND DESIGN has celebrated its twentieth anniversary. We reproduce a design for a stained glass window for the school by a student, Hernando G. Villa.

THE SCHOOL OF THE ART INSTITUTE OF CHICAGO allows entry into classes at any time of the year. The facilities of the Art Institute form a material advantage to the school.

THE SCHOOL OF THE SAN FRANCISCO ART ASSOCIATION, now in its new building, is holding a summer term of eight weeks.

SPECIAL ATTENTION to metal working, book-binding, wood-carving, modeling, leather working and pottery is given by the Rochester (N. Y.) Mechanics Institute, Theodore Handford Pond, superintendent.

GEORGE BREHM AND FLETCHER C. RANSOM are among the instructors in the summer course of the School of Practical Illustrating, New York City.

THE SCHOOL OF THE MUSEUM OF FINE ARTS, Boston, has awarded the Paige scholarship to Miss Alice Ruggles, of Buffalo, N. Y. Under the auspices of the school the Stuart Club provides attractive quarters for women students going to Boston.

ALPHONSE MUCIA conducts special courses in design at the New York School of Applied Design for Women.

IN AUGUST, SEPTEMBER AND OCTOBER Alexander Robinson will hold classes in Holland.

AT VINEYARD HAVEN, MASS., Arthur R. Freedlander will conduct outdoor classes to September 15.

AT POINT PLEASANT, N. J., outdoor sketching classes under Miss Rosalie Palmié will continue to October 1.

NOTABLE STUDENT WORK at the recent exhibition of the Young Women's Christian Association, New York, were the clock case by Miss Bessie Twiggs, reproduced herewith, and a terra cotta sconce for three electric lights by Miss Lulu Macher.

AT AN EXHIBITION of the work of children of the New York public schools held on March 9, at 20 West Thirty-fourth Street, Dr. James P. Haney, the Director of Manual Arts, made a short address on the International Congress of Art Teachers, which will meet in London in 1908. The American sec-



"EL ENCANTO DELLA MUSICA"  
DESIGN FOR STAINED GLASS

BY HERNANDO G. VILLA  
LOS ANGELES SCHOOL

## School Notes

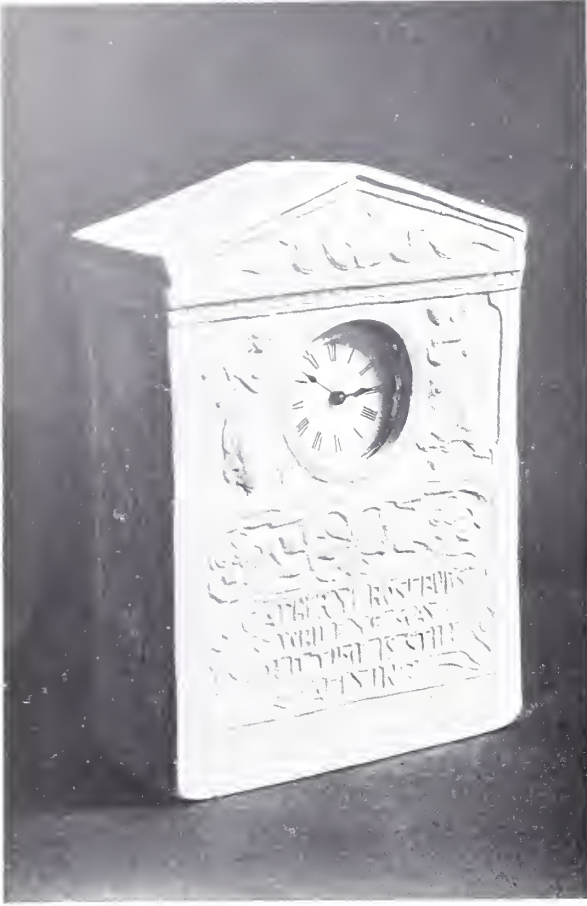

CLOCK CASE

BY MISS BESSIE TWIGGS

tion of the Congress is in charge of an Advisory Committee of twelve of the leading art teachers in the country and an associate committee of 100,

representing the larger cities and towns throughout the Union.

This American committee, of which Mr. James Hall, Director of the Art Department of the Ethical Culture School, is chairman, has determined to exhibit at London a typical collection of art work from schools all over the country.

THE EMMA WILLARD ART SCHOOL, at Troy, N. Y., which enters upon its twelfth year this autumn, conducts outdoor sketching classes in the early fall months.

THE SCHOOL OF THE PENNSYLVANIA ACADEMY OF THE FINE ARTS awarded a long list of prizes and scholarships, distributing this year among its students a sum amounting to \$15,000.

THE SWAIN FREE SCHOOL, of New Bedford, Mass., will offer in the coming term the same course as was inaugurated last year. Two special departments in frame making and stenciling have been added.

THE NEW YORK SCHOOL OF INDUSTRIAL ART, Elisa A. Sargent, president, gives special attention to professional design.

THE COLUMBUS (OHIO) ART SCHOOL, under the direction of John E. Hussey, begins its twenty-eighth year in October.

THE ART STUDENTS' LEAGUE OF BUFFALO is holding a summer school at the Albright Art Gallery. Among the teachers are David Ericson, Theodore M. Dillaway and Miss Mabel Rodebaugh.



WORK IN MODELLING

BY STUDENTS, Y. W. C. A., NEW YORK

## Architecture and Decoration

### RECENT PUBLICATIONS IN ARCHITECTURE AND DECORATION.

THE first volume of Dr. Russell Sturgis's "History of Architecture" (The Baker & Taylor Company), which will be completed in three, covers the building periods of ancient Egypt, Western Asia to 300 B. C., Greece, the Italian peoples before Roman control and the Roman Empire. Some twenty years' experience in earlier manhood as a practising architect gives this encyclopedic author a solid footing on his subject, which will make the later volumes, dealing in matters of less conjecture, even more interesting still. Special investigations in Greek and Roman methods of construction are admirably reviewed, and extended by study of the buildings. Valuable chapters, also, are those on Greek and Roman traits in the disposition and grouping of buildings. The inference that the Greeks cared greatly for picturesqueness of group or had much of the feeling for landscape is put under considerable doubt.

The building of the Greeks is difficult to comprehend in fulness, because in the remains it is chiefly a matter of porticos. Herculaneum and Pompeii display here and there the adaptation that the Roman made of his impressive style for simple, domestic buildings. But the Roman problems are hindered by reason of the fact that there is no one great building in such a state of preservation as to give a general detailed and practical answer to requirements and the artistic touch of the designer. Accordingly, we are left in the necessity of taking up building by building, which to some extent is the plan followed in this book. The volume is handsomely printed and carries 355 illustrations, six in photogravure.

LEANING frankly on Bancroft in its historical passages, George Wharton James's study of the Franciscan Missions, "In and Out of the Old Missions of California" (Little, Brown and Company), will probably most interest our readers in its treatment of mission architecture, mural decoration, furniture and woodwork, silver and brass ware and statuettes of saints. One of the strongest features of the architectural style, Mr. James considers, is the treatment of the sides of the pediment in steps and curves. The tower and fachada are noted in detail, as used in various missions, and a similar examination is made of columns, pilasters, arches, where a puzzling irregularity occurs in spacing, and buttresses. In the matter of interior decoration the padres seem less successful, though the Franciscan historian, Zephyrin, minimizes their responsibility. The only examples well preserved are the Missions of San Miguel Arcangel and Santa Inés. The wall decorations appear to consist of distemper paintings on plaster, executed without any noteworthy taste in color. In spite of the current term, "Mission furniture," it would appear that no such distinctive style was evolved in furniture. Beyond the furniture brought over from Spain, and a few examples of oriental origin, the furniture of the missions shows nothing but the simplest provisions to meet bare necessities, and in no way constitutes a style. Much of the silver and brass ware was brought from

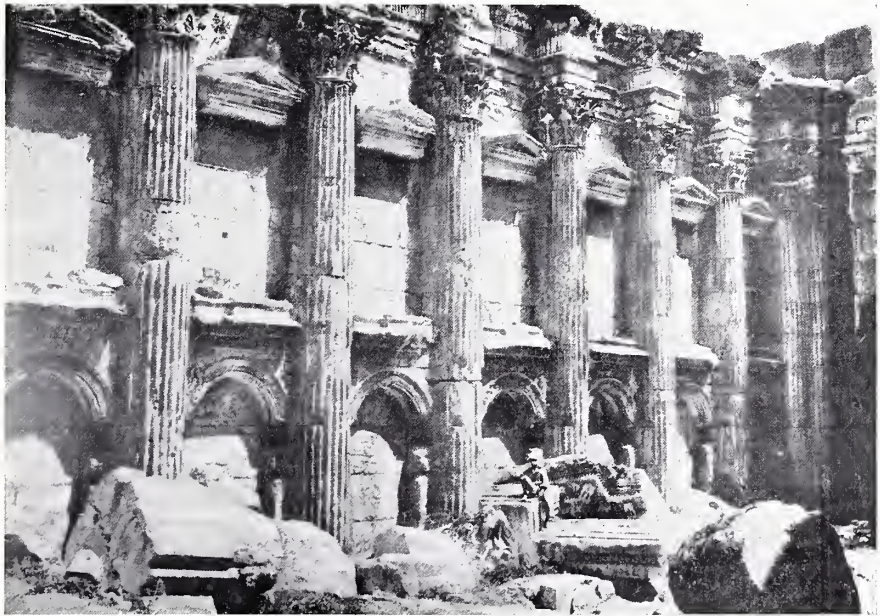

Copyright, 1906, by The Baker & Taylor Company

INTERIOR OF SMALLER TEMPLE  
AT BAALBEK, SYRIA

HISTORY OF ARCHITECTURE  
BY RUSSELL STURGIS

## Architecture and Decoration

Mexico or greater distances. Spanish traits are frequent in design and handling, though some examples suggest the Navaho silversmith or the Moor. Copper was wrought at several missions, notably San Fernando. Sixty-six plates illustrate this suggestive book.

THE choicest pieces of furniture and objects of art assembled by Mr. Talbot J. Taylor in his country home at Cedarhurst, Long Island, presented in a series of 187 illustrations ("The Talbot J. Taylor Collection," G. P. Putnam's Sons), make a useful record for study of styles. It is a pity that convention requires that the commentary to such a series of plates should always insist that the zeal and acumen of the collector has not run away with the taste proper to the mere householder. Among the views of entire rooms, for instance, that of the library of Talbot House, unless the photograph distorts the spacing of a room, plainly of unusual size, has as little right to the connotation of its name as the hold of the *Mayflower*. Without disparagement of either aim, it should be evident that one cannot, within the limits of a single dwelling, serve both a catholic passion for historic styles and the impulse of creative unity. But rare is the man born of woman, and, therein, to some delight in the decorative crafts, who would not give his head or his hat or some other useful part of his possession for one example or another here displayed to view. The craftsman as

well as the collector will find the book worth pondering.

HERBERT E. BINSTED has collected from serial publication the drawings numbering upward of a thousand, which he has made for the use of designers and craftsmen. The narrow folio, "Useful Details in Several Styles," (John Lane Company) comprises 144 plates, showing from five to a score of careful line drawings each. The contents are divided in four sections, each style sub-division being prefaced by a brief memorandum on the historical placing of the style and the designers who obtained note in its development. Section I covers Gothic and Moorish; Section II, Francis I, Henri II, Henri IV, modern French; Section III, Louis XIV, Regency, Louis XV, Louis XVI and Empire; Section IV, English Renaissance, Elizabethan, Jacobean, Chippendale, Sheraton, Hepplewhite and Adam. Mr. Binstead says in an introductory note: "All the details given have been gathered from the most authentic sources, and may be unhesitatingly accepted as trustworthy and characteristic types of the styles they represent."

A SERIES of studies of drapery for the use of artists and designers has been prepared from drawings by H. Friling in "Gewandstudien für Kunst und Kunstgewerbe" (Bruno Hessling). The drawings are particularly adapted for glass work, mural

painting and illustration. The forty-four female figures, in a variety of poses habitual in such decoration, have been drawn in outline; and the draperies, drawn in crayon, or in line and shading combined, are studied with minute care to show the arrangement and setting of loose material on moving limbs. The drawings are finely reproduced by heliotype process on sixteen plates,  $12\frac{3}{4} \times 16\frac{1}{8}$  inches. The difficulty



Copyright, 1905, by Edith E. Farnsworth

INTERIOR OF  
SANTA BARBARA MISSION

OLD MISSIONS OF CALIFORNIA  
BY GEORGE WHARTON JAMES

## Architecture and Decoration

often found in getting these effects in posing should make this publication useful for ideas and suggestions in church decoration, poster work, decorative painting, etc. The plates are tied in an attractive and durable portfolio backed and edged with cloth.

MUCH practical information is compacted in Paul N. Hasluck's little primer "House Decoration" (Cassell and Company, Limited). The book is fully illustrated with line drawings and diagrams, and the instructions are presented succinctly. Persons who try their hand at the actual

processes of putting on paint, mixing pigments, working with distemper, wallpaper, etc., without being able to boast any appropriate training in the corresponding trades, should, if they have any knack for the thing, be able to shift and experiment for themselves with the aid of this handbook. The chapters on decoration of walls and ceilings and on painting and papering rooms are in themselves short handbooks of instruction. Those on pigments, oil, driers, varnishes, tools, mixing paint, etc., are conveniently arranged for reference. A useful description of a variety of brushes is given with directions for their use and care.

In "HOUSE HINTS" (House Hints Publishing Company), C. E. Schermerhorn describes details concerning the site, location, arrangement, construction, plastering, heating, plumbing, lighting, decorating, and furnishing of the house, an admirable notebook of practical advice. The book is arranged in little paragraphs with index, which makes it a convenient treatise to turn to. Something like 150 subjects in all are treated in brief fashion. The author's view shows itself in the foreword:

"Many of the annoyances that attend house building would be avoided if the knowledge acquired during the process had been possessed in the beginning, and the house builder should, therefore, familiarize himself with as much as possible that concerns the erection of houses before he starts. Bear in mind that, in building enterprises,



Photo by F. Mason Good  
A GARDEN POOL

ROCK AND WATER GARDENS  
BY CHARLES THONGER

the unexpected is bound to happen, and the house that exists in the mind's eye is rarely embodied and the ideal seldom realized."

IF THERE is one thing which no good gardener can tolerate it is the "rockery." But a heap of stones and brick rubbish with a few stunted ferns and a tangle of dusty ivy is not a rock garden. More often than not, too, the attempted rock garden is laid out in some tree-shaded corner where sun and air, the very essentials to the happiness of rock plants, never penetrate. If a crop of stones is desired, one can always go and farm on a glacial morain. It is to those who are genuinely interested in the Alpine plants themselves that Charles Thonger addresses himself in his "Book of Rock and Water Gardens," (John Lane Company). It is commonly supposed that plants usually found in high mountains cannot be grown successfully in lowland gardens. The fact is that it is not so much the altitude that suits these delightful miniature flowers, but rather the absence of plants of robust habit and coarse growth in the surroundings. The silene and diminutive mosses find a shelter in the crannies, and the Alpine poppy secures a foothold on barren spots because there more vigorous growth will not smother it out of existence. Nine rock gardens out of ten are hopelessly overgrown and overcrowded. The plants must be kept in colonies for successful results and, with larger plants in the neighborhood, root restriction becomes of first importance.

## Weaving in a Hand-Loom

WEAVING IN A HAND-LOOM  
BY MABEL TUKE PRIEST-  
MAN

WITH the ever-growing love for the simple and beautiful, it is not surprising that the desire has become almost universal for hand-made things of all kinds. Naturally we turn to what was made in the early Colonial days for inspiration in evolving old-time handicrafts.



RAG CARPET LOOM

Weaving is fast becoming a popular occupation, but the only drawback to it is that it is not always easy to find out how to do it, although the process is very simple. People are buying old looms and giving them a place of honor in the garret, and spend many hours in working out for themselves intricate weavings of all kinds. Success has attended their endeavors, for not only can most beautiful hand-woven rugs of delicious coloring be found at the various arts and crafts exhibitions, but even in the stores the genuine article can be obtained.

Manufacturers found that the quaint simplicity of the Colonial rug could not be duplicated in machine-made weavings, and the result is that artists are designing for them and beautiful hand-woven rugs are being made in large quantities and good weavers are being eagerly sought after to supply the increasing demand.

Our grandmothers were content to use old material,

saving the wornout sheets and underwear for this purpose. These they dyed in soft colors with indigo or madder that grew so abundantly in many parts of America; but the modern rugs are made entirely of new material. All kinds of cotton stuffs are brought into service. Figured cretonne, gingham, lawn, denim, print, satcen, duck, unbleached muslin, cotton flannels, ticking, and even rope and roving yarn are being utilized. As it is impossible to be certain that all the materials obtainable in the market are fast in color, some prefer to buy the material in the white and have it dyed a solid shade, so that the rugs can be washed without any risk of the color fading. An attractive rug known as a Priscilla is made of specially dyed material, although this rug is never found with fancy borders. It has the hit or miss effect of old rag carpeting, which is obtained by a strip of white and strip of color being twisted together and then being woven. It is finished off at each end by three plain borders of white or color. The same make of rug is made in plain material, specially dyed, and then is finished off with three plain borders of white. These are the only two styles in the Priscilla rug, but they can be obtained in all sizes even up to a 12x15. The warp is usually white.

The Martha Washington rugs show quite an un-

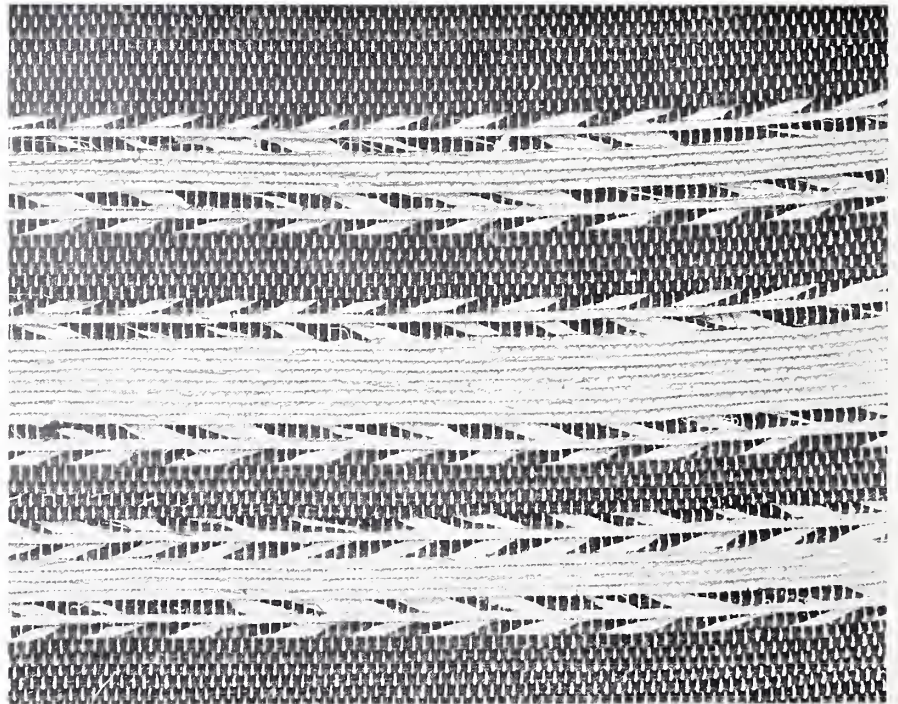

PLAIN FABRIC RUG

CROW'S FOOT BORDER



## Weaving in a Hand-Loom

usual border treatment. They are made of cretonnes or ducks, with quite intricate and artistic designs worked out in the borders. They also are made in all sizes.

There is another kind of rug entirely different from the two we have just mentioned. It is known as the John Alden. The weave is much looser and the rug is softer to the touch than either of the other makes. A description of how these three varieties of rugs are made and the borders worked out should be of help to the craft-worker who is interested in taking up weaving.

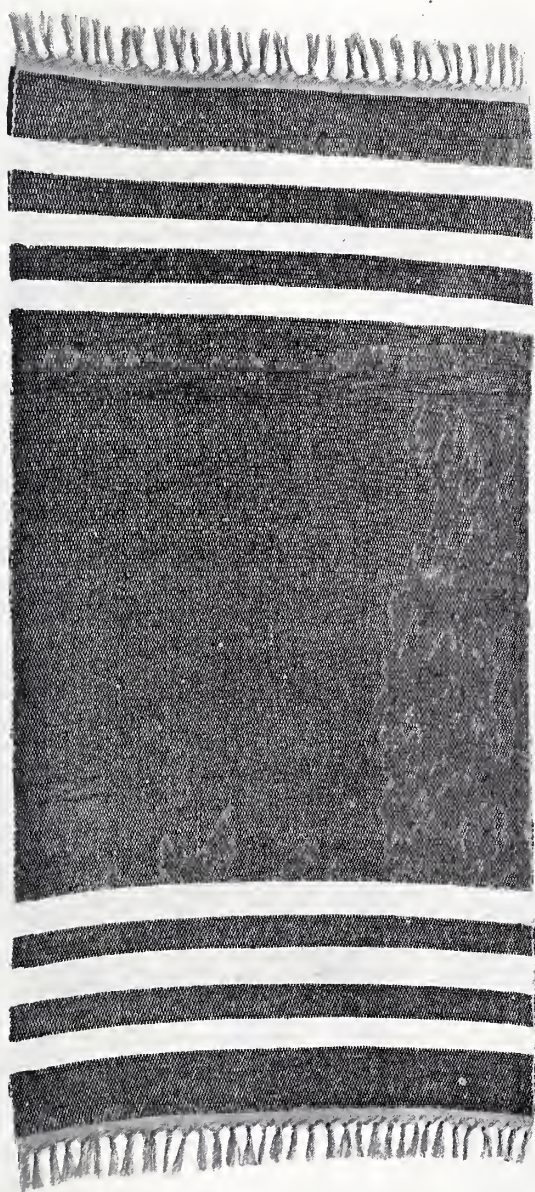

PRISCILLA RUG

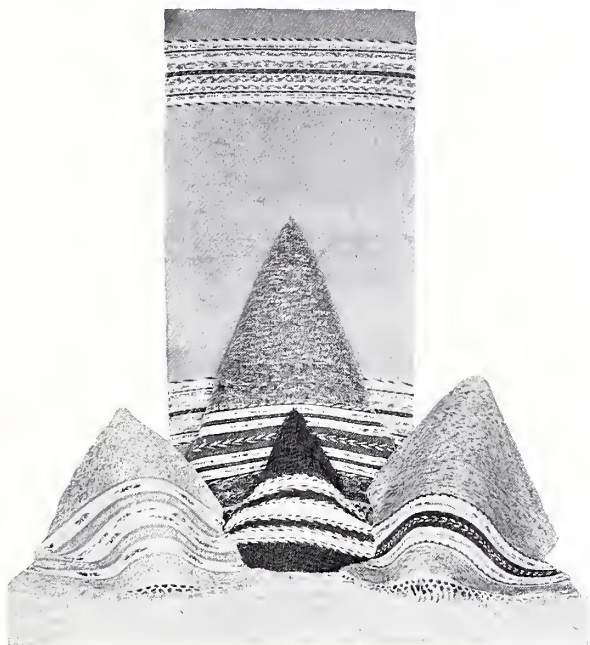

MARTHA WASHINGTON RUGS

The question most usually asked by the beginner is how much does a loom cost, and the questioner will smile when told that they can be obtained from \$5.00 to \$125. A loom at the smaller figure must be picked up, and this is often done in country places and in old-fashioned towns where weaving has become a thing of the past. The old-fashioned loom is just as good for the making of artistic rugs as the more up-to-date steel ones. There are also some convenient little hand-loom made for about \$25.00 for craft-workers, and these can usually be ordered through the Arts and Crafts Societies, who keep in touch with the various makers. Small looms are made for the use of art students at the schools for the small price of \$6.00. Failing to pick up a yard-wide loom at a small figure and yet wishing to master the art of weaving before buying a more expensive new loom, the narrow \$6.00 one might prove a good investment. When later a larger one is purchased, the small one could always be utilized for evolving border designs, which are much better done in the loom than on paper, and to have such a one at hand for experimenting is often quite a boon.

When buying an old loom it is necessary to know all the parts that go to make a loom, as the cost of making a missing piece is somewhat expensive. It should consist of a frame, a beam, heddles, a lay, one or more reeds, several shuttles and a templer. Very often a wheel for winding is included, but this is not a necessity, as there is a

## *Weaving in a Hand-Loom*

mechanical device for winding, which can be obtained for about \$2.00.

Having made a satisfactory purchase and having had the loom properly put up, preferably by a weaver, the next thing is to procure the warp. The commercially dyed ones are not fast in color, whatever their makers claim, and therefore white warps are usually made use of for washable rugs. The man who supplies the warp is usually in touch with a beamer, and as the beaming of a warp is not an easy task for a beginner and is somewhat difficult to explain I would suggest that the beam of the loom be sent to a beamer and warped with enough warp to make 25, 50 or 100 yards of weaving, according to the enterprise of the craft worker.

After the beam has been placed in the back of the loom the warp threads must be carried from the beam over the back cross-bars and threaded through the two sets of heddles, then through the reed and over the front cross-bars of the loom, where it is attached to the iron bar which is rolled under the front cross-bar. This sounds somewhat complicated, but it is really quite easy, especially if you can see it done for the first time by a weaver. In a town it is always possible to get hold of an old rag carpet-weaver, or a man who has once been a weaver, to show the worker the proper

threading of the loom and to describe what each part is intended for.

Having once learned this, the process of weaving is extremely easy and only needs practice to make artistic weavings.

Having prepared the loom for weaving, the next process is the preparation of the fabric. The old-fashioned way was to cut inch-wide strips with scissors, but the better way is to get a roll of material tightly wound and cut it in slices like a loaf of bread, with a sharp carving knife or, if a rough surface is preferred, the tearing gives this effect. In order to get all the strips the same width, it is well to measure the inches on a table, so that the pencil marks are a guide for the knife or scissors. If the material is to be torn, a couple of inches should be thus measured and cut with scissors, so that each strip is torn the same width. Heavy goods should be about one inch in width, while light-weight material should be an inch and a half or two inches. All kinds of materials called "seconds" can be utilized for weaving, as a few irregularities in the color, or weave, do not show when the fabric is woven. In all the large towns there are buyers of seconds, where such materials can be purchased.

The beginner usually finds a great deal of difficulty in determining how much material to buy. The most practical way of finding this out is to

weigh a roll of new material and write down in a notebook its weight, and the number of yards in the piece. After it is woven the number of yards of weaving made can be ascertained. It will be found that some materials go much further than others, so that an accurate number of yards cannot be given. As each rug is cut off the warp it should be measured and weighed and thus the weight of the rug will be found and the number

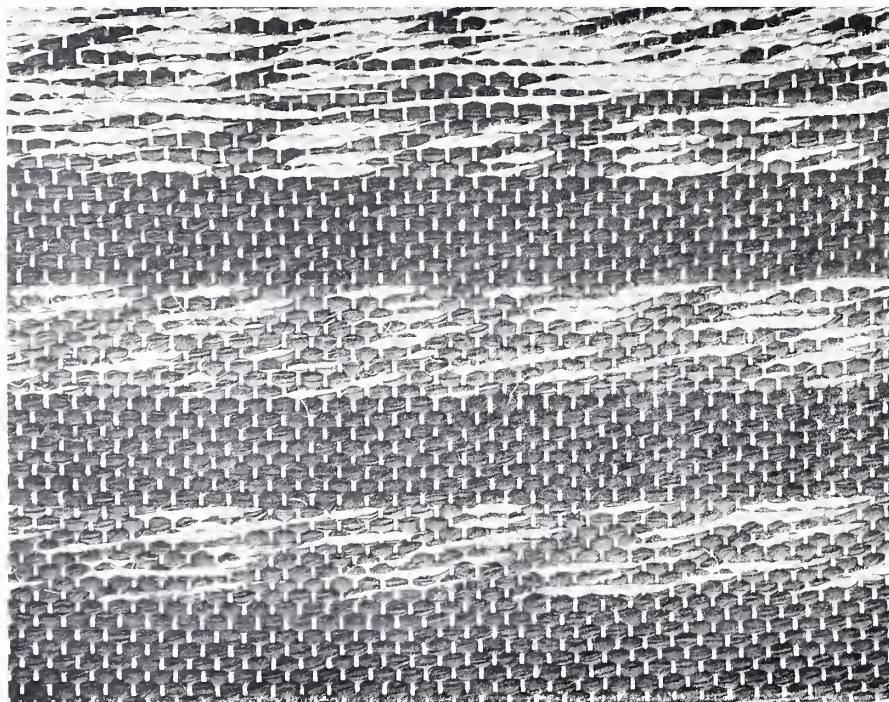

DETAIL

PRISCILLA RUG

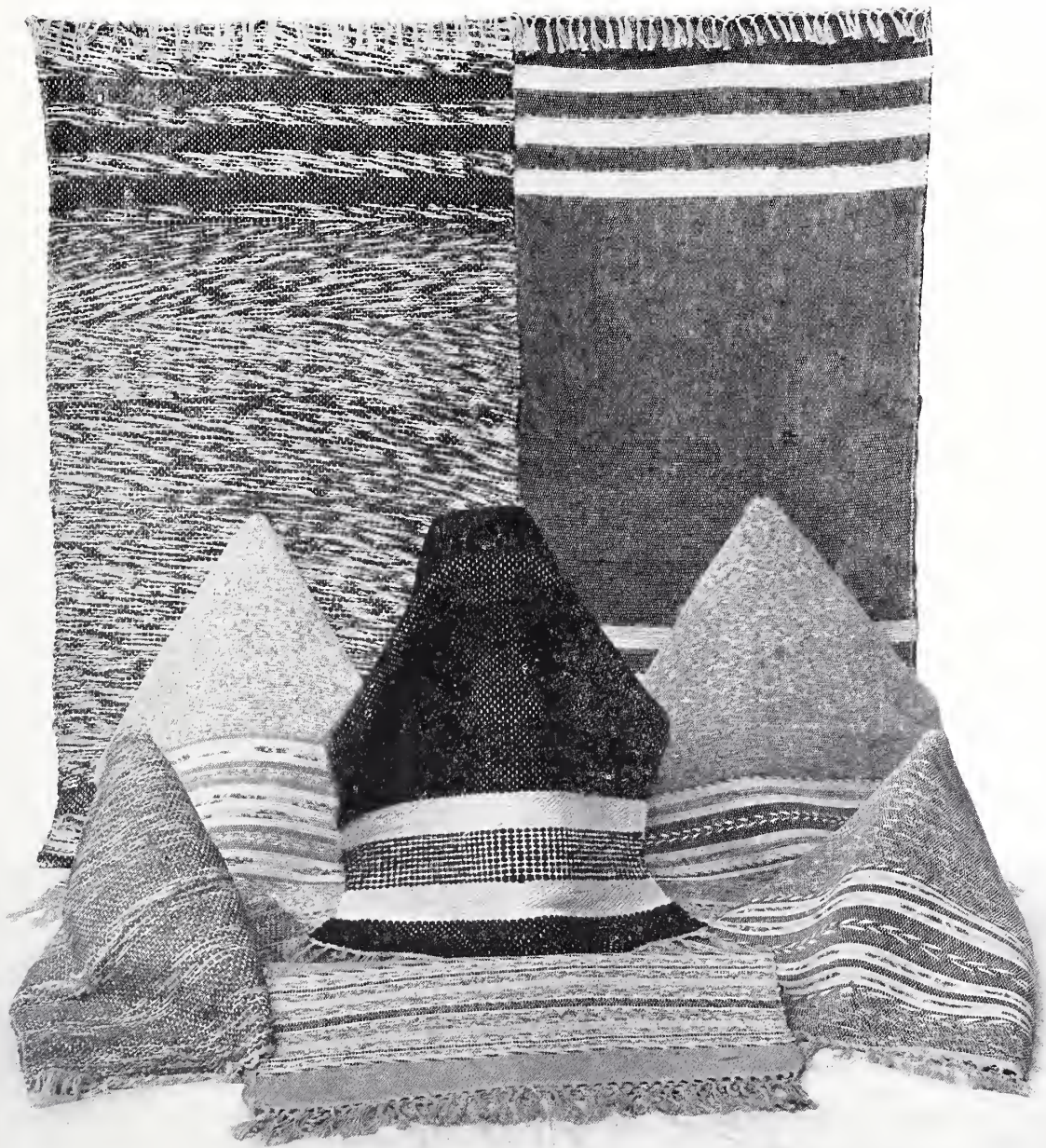

GROUP OF  
HAND-WOVEN  
FABRIC RUGS

## Weaving in a Hand-Loom

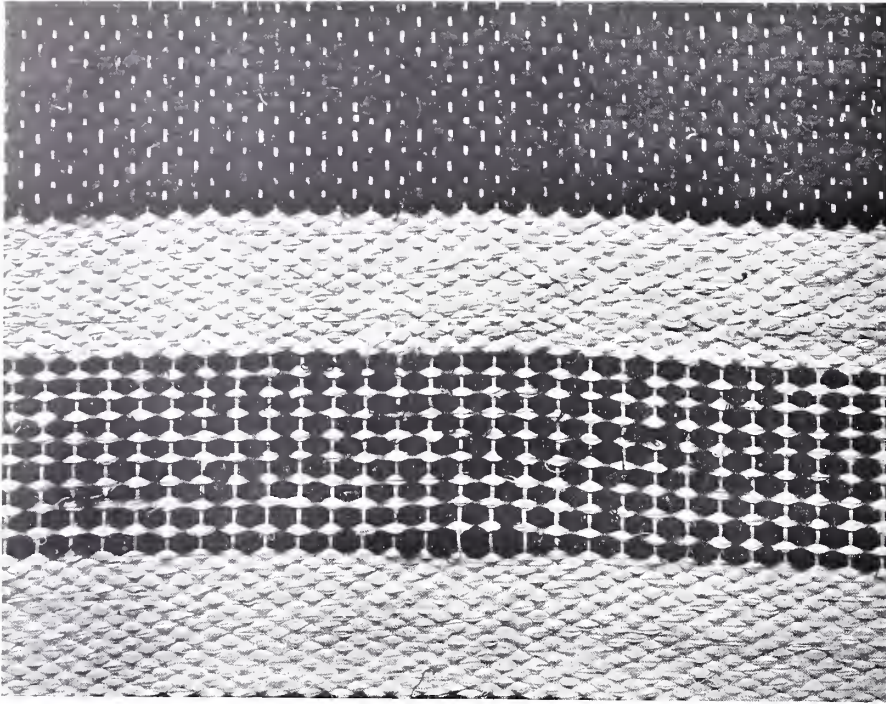

DETAIL

JOHN ALDEN RUG

of yards of weaving ascertained. Five to seven yards of duck or denim will usually make one yard of weaving. A well-made rug should contain about  $2\frac{1}{2}$  pounds of material, including the warp. If a turkey red twill is used, at least ten yards would be needed for a yard of weaving, so it will be seen that it is not always the cheapest material that makes the least expensive rug.

After the material is divided into strips it must then be wound into balls. It is then wound onto an iron rod, which is placed on a winding-wheel. It is then ready for the shuttle. Pull the end of the material through the hole when it is ready for work. The old-fashioned weaver very often stood to weave, but it is much better to sit, and it is very important that the seat is at a convenient height, not only for throwing the shuttle but for working the treadles.

Begin to weave by pushing the left treadle down with the left foot. This will cause a gap between the two layers of warp. Now take the shuttle in the right hand and throw it to the other side of the loom between the warps, taking hold of the part of the loom which contains the reed with the left hand. Do not draw the material entirely through the warp. About two inches should be left sticking out, and this must be turned back and lapped round the warp at the side of the weaving. After the mate-

rial, or shot, as it is called, has been thrown, pull the lay which contains the reed forward, and press the right foot down, releasing the left, which will make a reverse gap between the two layers of warp. Then place the shuttle in the left hand and throw from left to right between the warps, pounding the lay between each throw. This is the actual process of weaving, and on these principles all kinds of fancy weavings are evolved. When

the end of a strip is reached, it is not necessary to sew it to the new. It is better to cut the end of the piece-woven strip, and the new strip to a point, and overlap them, so that they are not thicker than the rest of the shot. This is neater than sewing, which often comes apart and shows the stitches through the warp.

Every loom should have a templer, which is an attachment made of flat, narrow strips of wood, the width of the material. It has hooks and points at the end, to catch it to the selvage of the cloth, in order to keep it firmly stretched while the lay is pushing the weft into place.

We will suppose that the beginner is going to make a 3 by 6 rug. The first thing to do will be to calculate enough warp for the fringe. Then thread the shuttle with warp and weave a band about two inches wide. This is called a heading and hinders the material from fraying at the ends, giving a strong, firm finish to the rug. The old rag carpets were apt to have too little heading, and they sometimes frayed in consequence. Then proceed to weave the selected color for the rug. We will suppose that a blue rug with white warp and white borders is to be made. Weave five inches of the blue material. Then take the white material and weave two inches of white. Then weave three inches of blue and another two-inch band of white. Again

## *Weaving in a Hand-Loom*

weave three inches of blue and two inches of white and proceed with the solid color of the rug.

In weaving a rug a certain length, it will be found there will be 25 per cent. of shrinkage or, as the weavers call it, "take up," so that this must be allowed for in planning for the length of the rug. To gauge the length of a 3 by 6 rug, take a length of tape and pin it firmly to the woven heading, and then indicate on it the length of forty-five inches. As the rug is woven the tape is visible. When the mark of forty-five inches is reached, this is the middle of the 3 by 6 rug. Reverse the tape and pin it firmly to the center of the rug and proceed to weave the balance, the tape indicating where the borders come. This simple plan is not often thought of by amateurs, and yet it saves a lot of trouble, and enables the weaver to make a rug of given length. Of course, no one cuts out of a loom only one rug. A batch of rugs is woven, and, if possible, it is best not to remove them until the whole length of warp is used up. If this is not practicable the warp can be cut near the lay in such a way that the heddles will not have to be threaded again at the next weaving.

In looking at our illustration of a plain Priscilla rug, it will be noticed that it is just what I have described in the blue and white rug. The details of a Priscilla shows how the white and colored material looks when woven. The two colored materials are wound on the iron rod and put into the shuttle and

woven as one shot, being cut or torn narrower than the plain part of the material which constitutes the borders of the rug. This kind of border is perfectly plain sailing.

The crow's-foot border is just as easy, but looks somewhat difficult until the mysteries are solved. It is made by having a dark and light material in one shuttle and the white in the other. Take the shuttle with the twisted materials and throw one shot. Then take the white and throw one shot of it. Then take up the shuttle on the return journey containing the two colors, which will give the crow's-foot effect. Then throw four shots of white and begin again with the twisted material. Then one more shot of white and another shot of twisted. This makes one complete border. After weaving five shots of the plain material the second border is woven, which has two more shots of white than the first and third.

The Martha Washington border looks very complicated, but a study of this will unravel its mysteries. Our detail illustration shows a rug made of green and pink figured cretonne. The pink is matched for the border, and one shot of this is used and three shots of white. Then two shots of twisted materials are thrown, giving the crow's-foot effect. This must be much more carefully twisted for border-making than for making a rug like the Priscilla. Unevenness in the latter does not signify,

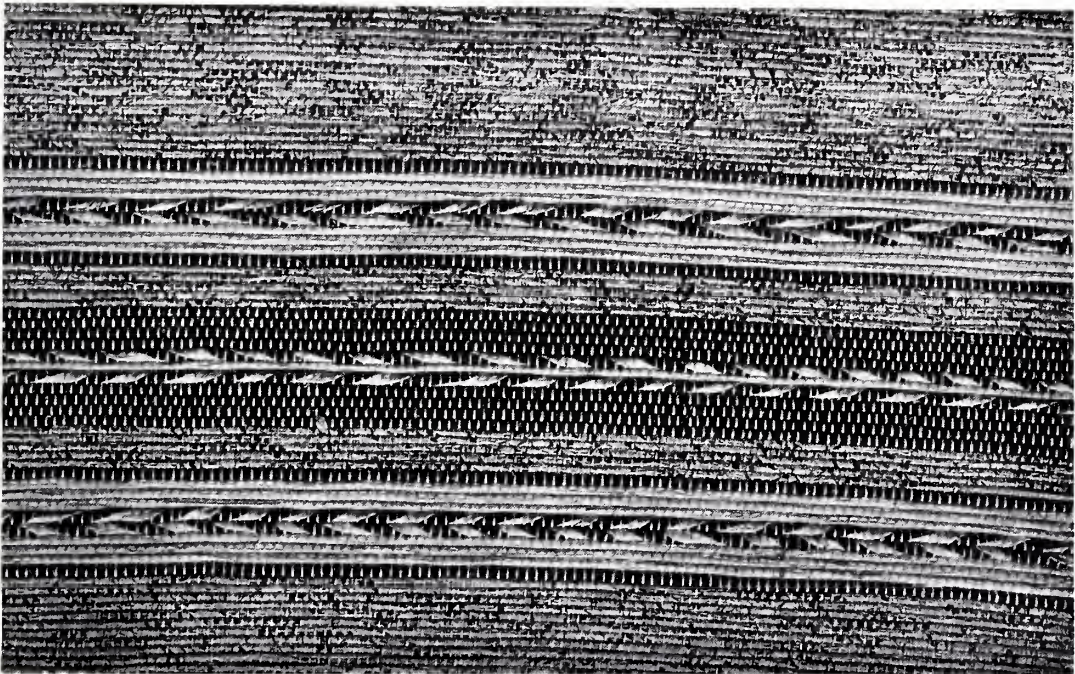

DETAIL

MARTHA WASHINGTON RUG

## *Weaving in a Hand-Loom*

but the crow's-foot must be perfect or it looks unworkmanlike. Do not be led astray by your friends speaking of poor work as interesting. I have noticed work from a studio badly matched, badly woven and irregular, and instead of being condemned it was only called interesting. I throw out this hint so that workers who are in earnest will not be deceived by such criticism. I think that every craft-worker should make a point of making her own border designs. There is so little opportunity for individuality that only in this way can we make our weavings express our own originality.

A clever young man thought out the interesting border of diamonds and evolved it by weaving the material in clumps of colors which he calculated to form a design. This was then torn into strips and woven in the ordinary way. It would be difficult to describe at length how this was arrived at, but it should be a help to show the possibilities there are for new ideas in border weaving.

Difference in texture can be gained by adjusting the warp. Instead of threading every hole in the heddle skip alternate holes, and put two warp threads instead of one in the others. The result will be a rug like the John Alden. The red John Alden illustrated has a border of seventeen shots of white, followed by alternate shots of red and white for the center of the border, which consists of sixteen shots. Seventeen more shots of white are

woven, and that forms the border at each end. This is a complete change from the triple borders which most of the hand-woven rugs have, and yet occupies nearly as much space on the rug itself. This weave being very soft is well adapted for portières and pillows. When weaving it is not necessary to pound with the lay, as the firmness necessary for a rug is not suitable for a hanging that must fall in soft folds. Another thing to remember when weaving portières is to always make use of the softest kind of material. Canton flannel, Shaker flannel and unbleached muslin are admirable for this purpose, but the harsher denims and cretonnes are not nearly so well suited for draping. There is a material called roving-yarn which is very attractive for hangings. This can be obtained from houses that sell rope and string. It is something like lamp-wick. The latter can be used after home dyeing has been done and is very attractive. It has not often been utilized for weaving.

When the warp is all used up it is cut out of the loom and the weavings are laid on a large table. The fringe is cut across and each rug is gone carefully over with shears to remove any irregularities that would catch the dirt.

The next process is the knotting of the rugs. Knotting rugs takes time, but it well repays the labor.

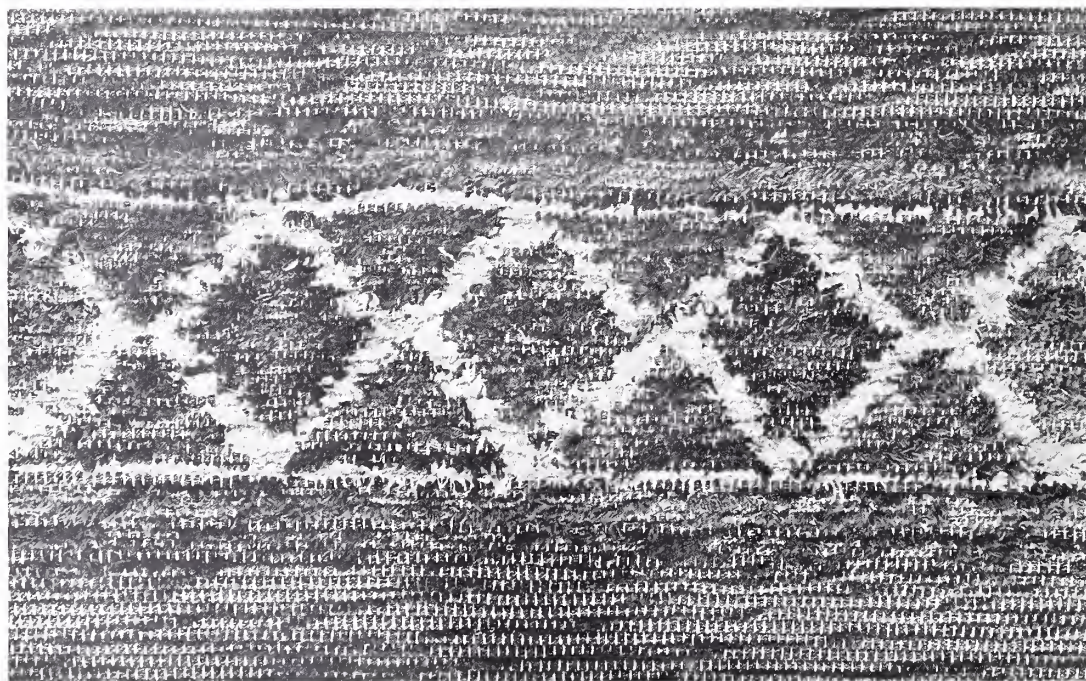

WAVERLY RUG

MADE FROM HAND WOVEN CLOTH





"WHAT'S O'CLOCK?" FROM AN OIL-PAINTING BY E. A. HORNEL.



# THE STUDIO

**M**R. E. A. HORNEL'S PAINTINGS OF CHILDREN AND FLOWERS. BY E. RIMBAULT DIBDIN.

Two or three years ago I had several discussions with a well-known personage about two pictures—very dissimilar in style—which happened to be hanging in the same room at an exhibition. At first he cared for neither, considering them mannered and affected, which they were, if judged by current academic standards. One day he pointed to Mr. J. D. Batten's exquisite *Beauty and the Beast*, and said "I can understand your liking that, and begin to agree with you; but I can't follow you in regard to the other—how do you explain it?" The other was a little picture by Mr. Hornel, one of the most perfectly charming of his inventions. My explanation was that the conventions and mannerisms of Mr. Batten, though perfectly individual and novel in expression, were of the school that had been familiar to us from childhood—which had played a large part in English Victorian art; that, on the other hand, Mr. Hornel's ideals and mannerisms were new and strange; their external influences chiefly from that far Eastern art which in our boyhood was not clearly recognised as art—or, at any rate, as especially beautiful art. The school from which Mr. Batten derived prepared us to understand the importance of decorative quality in art, and the

appeal of its mediævalism to our hereditary instincts helped it to succeed; while the strangely alien beauty of Chinese and Japanese objects in our drawing-rooms still spoke in vain, till stubborn interpreters slowly forced us to attend.

I am glad to say that my sceptic afterwards bought the Hornel, sorry that he did not further enrich himself by securing the Batten.

There is so much that is unconventional in Hornel's art that what puzzles me most is its success. It seems such a short time since Liverpool enjoyed one of its most exciting art battles, over the purchase for the Corporation's permanent



"FAIR MAIDS OF FEBRUARY"  
(The property of the Glasgow Corporation)

BY E. A. HORNEL

## E. A. Hornel

collection, of Hornel's *Summer*. Such splendour of originality should have secured him a lifetime of neglect and derision; he has made no concessions, yet here he is, comparatively young, and recognised far and wide, bought and admired. Even his *penchant* for children as subjects does not explain it, for he despises the conventions of grace and prettiness that surely touch the popular heart. There is nothing the true Briton loves better on canvas than a child—unless it be a horse or a dog—but it must conform more or less to his ideals, which are not Hornel's. He paints the *gamins* of Kirkcudbright as Murillo painted those of Seville, with the uncompromising fidelity not of the satirist but of the true nature-lover, for whom the unkempt, ragged urchin concerned in the manufacture of mud-pies is lovelier than the daintiest suburban miss in pink muslin and artificial curls. There are still many who turn in disgust from those frank records of peasant children with faces lovely as rose-petals, but oh, so unconventional! However, these are no

longer in a majority, and Hornel may be regarded as safely "arrived," although he has not, like his old-time comrade, Mr. George Henry, been stamped with the Royal Academy's hallmark. But that distinction is not likely to come to one who reckons little of academies and societies, avoids London, and regards even familiar Glasgow as a place to be visited as seldom as possible.

Glasgow responds by believing implicitly in Hornel; and Liverpool, which gave him his first formal recognition by the purchase of *Summer* in 1892, is no less appreciative. Again, in 1904, it bought one of his pictures, *The Captive Butterfly*, for the city's permanent collection; and nobody thought of objecting. Other public galleries in which pictures by Hornel have a place are those of Leeds, Bradford, Rochdale, Bury, Brighouse, Toronto, Buffalo, U.S.A., and Ghent.

To look back at the newspaper records of the Hornel dispute in 1892 helps one to realise the progress made since then towards catholicity in

artistic judgment. The papers were full of all sorts of opinions, chiefly hostile and contemptuous; the recommendation to buy *Summer* was referred back by the City Council to the Art Gallery Committee, and only Mr. Philip Rathbone's stubborn belief in his opinion saved the situation. It was complicated by the opposition of Alderman Edward Samuelson, Mr. Rathbone's predecessor as Chairman of the Art Gallery Committee, to whom, emerging from his retirement in the Conway Valley, the newer manifestations of art were startlingly and displeasingly discordant with his mid-Victorian ideals. His protests provoked a violent attack in "The Speaker" by Mr. George Moore, who proved to his own satisfaction that "The Alderman in Art" was almost as deadly as "The Royal Academician



"AUTUMN"

BY E. A. HORNEL



*(Buffalo Permanent Gallery)*

“EASTER MORNING”  
BY E. A. HORNEL

*E. A. Hornel*

in Art," and acclaimed Mr. Rathbone a true connoisseur, in splendid ignorance of the fact that Mr. Rathbone was just as municipal as his old friend and colleague, and therefore (according to Mr. Moore's theory) incapable, *quâ* councillor and future alderman, of beginning to understand anything about art. I am glad to find that on this occasion I happened to be on the side of the angels, having been instantly captured by the charm of Hornel's colour. Fortunately I left the *subject* of the picture severely alone—a precaution in which Mr. Rathbone would have done well to imitate me when he afterwards lectured on its beauties, blamed those who could or would not understand it, and gave a detailed description, which, though clever, was wrong. The fact is that Hornel and Henry were at that time concerned not at all about subject; and, in their passionate quest of musical chords of colour, knocked their facts about in a most unfeeling manner.

The public, which has grown a little more tolerant in the last fifteen years, was inclined in 1892 to insist on the facts in a picture being treated with respect. My old friend and predecessor, Mr. Charles Dyall, tells with much humour how his life was made a burthen, after the purchase of *Summer*, by people who wanted an explanation of it. One dear old lady came day after day and took lessons on the subject, without, however, succeeding in seeing what he saw. One day, however, she skipped into his office with a radiant face and exclaimed, "Oh, Mr. Dyall, I do want to tell you that at last I've discovered one of the calves; please come and help me find another." That discovery doubtless gave her more pleasure than the colour harmony which the painter had laboured to produce, but which she had no skill to see. Since that time, while Hornel has never swerved from his devotion to colour, and has greatly de-



"REVERIE"

BY E. A. HORNEL



"BURNING LEAVES"  
BY E. A. HORNEL

## E. A. Hornel

veloped his exquisite sense of it, he has learned to be more merciful to those who demand lucidity of form. He has even begun to deal in distances—not at all in the spirit of Copley Fielding, but yet in a masterly style which shows that his one-plane compositions were not the result of inability to express atmosphere and manage perspective. With distances, however, as with his foregrounds, there is no quest of novelty for its own sake; the fine sweep of shore line and headland in *The Captive Butterfly* has been repeated again and again, each time with some new charm in the treatment, just as Hokusai reiterated the outline of *Fuji-san*, each time the same, yet with some fresh revelation of its majesty and beauty. One version of that fascinating bit of shore line is seen in *Reverie*, and the girl in the foreground, and the burnet roses and dry oak apples, are all more or less adapted from *The Captive Butterfly*. There never was a more inveterate maker of replicas than Hornel, yet one never thinks of grumbling, for he addresses himself to each new version with the fire which in most of us is exhausted in the first expression, and

consequently in each succeeds in being new. I have a crow to pluck with him, however, when he returns from Ceylon, over some of the later versions of this theme, in which a new and delightful colour effect is obtained by the introduction of the ordinary pink wild rose—a vegetable I have never as yet discovered disputing on sandhills the supremacy of the white-and-gold burnet rose. He is so true an observer, however, that I quite expect to be worsted in the argument.

If asked to define Hornel's art in a single phrase I should call him an exponent of the music of colour. As that, however, is perhaps too vague for English use (most of us being more or less colour blind), let us set it aside and call him a painter of children and flowers. He has painted many other things, notably birds, lambs, and other children of the four-footed sort, but his chief business is with children and flowers—the most perfectly melodious facts in the visible world of beauty, and therefore the best adapted to his method of composition. They are his melodies, to be woven into complex beauty with the harmony and counterpoint of his



“A SPRING IDYLL”

(Purchased by the Belgian State)

BY E. A. HORNEL

## Mr. Brangwyn's Decorative Panels at Venice



“ VENETIAN SERENADERS ”

BY FRANK BRANGWYN, A.R.A.

colour. I do not always see facts as he draws them, but that is because facts are less important to him than the radiant and fascinating fantasies that he weaves from them.

The usual method with children is to get them in your studio, keep them as quiet as you can with the aid of relatives, lollipops, and anecdotes, and paint them in a set pose. Hornel's method is different and better; he has a fine old house in Kirkcudbright, set in a large old garden, and he has improved its amenity by buying and demolishing or improving undesirable surroundings. All about his doors are the children of the poor, many of them with that peculiar and fascinating red hair of Galloway which he has so often painted and is said to be unlike any human crop. His garden is full of flowers, and the flowers of humanity are free to come in from the street and enjoy themselves in it. He meanwhile studies and paints them, the flowers and the children, in the open air. Thus his pictures are always spontaneous, full of daylight and lovely in colour. There never was a more thorough-going impressionist.

Early this year I wished Hornel and his sister Godspeed before they sailed for Ceylon, where he has gone in quest of new inspiration, just as he went off some fourteen years ago with Henry to Japan. I

look forward with eager anticipation to the result. The land and its flowers are new and splendid; its naked babies are copper-coloured; it is full of wonders that have been little noticed by European art.

E. R. D.

### THE VENICE EXHIBITION: MR. BRANGWYN'S DECORATIVE PANELS IN THE BRITISH SECTION.

The features of the British Room as designed and decorated by Frank Brangwyn two years ago,



SKETCH FOR PANEL

BY FRANK BRANGWYN, A.R.A.

## *Mr. Brangwyn's Decorative Panels at Venice*



"VENETIAN COMMERCE"

BY FRANK BRANGWYN, A.R.A.

are not unknown to readers of *THE STUDIO*. That this room with its painted panels was well received by the Venetians is evidenced by the committee's award to Mr. Brangwyn of a gold medal, and by the fact that they have once again given him the commission to paint new panels for the room which contains the British works at this year's exhibition. These decorations he has, under the pressure of many unfinished commissions of no small importance hanging over him, succeeded in executing recently.

If Mr. Brangwyn's work two years ago did anything toward keeping the standard of British

art well up in the minds of continental critics then his labours in this direction found ample compensation. That such was the case was proven to me by the statements of French, German, Hungarian and other nations' artists who were sent to Venice to decorate the rooms allotted to their respective countries. During my five weeks stay in Venice two years ago I heard on every side most flattering comments on the "Sala Inglese," both from press and people, and it seems that the same verdict has been passed on these later achievements.

The set of panels two years ago treated entirely



DETAIL OF PANEL, "VENETIAN COMMERCE"

BY FRANK BRANGWYN, A.R.A.





PASTEL STUDY FOR "VENETIAN SERENADERS." BY FRANK BRANGWYN, A.R.A.





DETAIL OF PANEL, "VENETIAN SERENADERS"  
BY FRANK BRANGWYN, A.R.A.



DETAIL OF PANEL, "VENETIAN COMMERCE"  
BY FRANK BRANGWYN, A.R.A.



SKETCH FOR VENETIAN PANEL. BY FRANK BRANGWYN, A.R.A.



## Mr. Brangwyn's Decorative Panels at Venice

of British subjects, but this year Mr. Brangwyn decided upon "modern Venetian life" as the subject for the decorations. Two of these, *Venetian Commerce* and *Venetian Serenaders*, he had completed, when a request came from the committee that the subjects should be British in character. In the two smaller panels the request was complied with, and *Agricultural Labourers* and *Steel Workers* are the subjects chosen. It is unfortunate that the matter could not have been left to the artist's own choosing, as the result is somewhat incongruous.

Of the two Venetian subjects treated, the *Venetian Serenaders* is, from a pictorial standpoint, perhaps the more interesting. To all who have visited the "City of the Sea" this will distinctly recall that most delightful scene on the Grand Canal which occurs on any summer's evening—a barque is shown full of Italians playing various musical instruments, with gorgeous lanterns hung over their heads, the rays from which are reflected in wriggling spots of bright colour in the deep blue water beneath.

Here Mr. Brangwyn has caught the spirit of such an evening—the light fantastic gaiety is brought out in the action of the figures as well as the gorgeousness of his colour. His composition is alive with quick rhythmic action of the musicians, and had I the space I might write pages on this element of Brangwyn's arrangements. It is not enough for him in any composition to merely show what the figure is doing. Take, for example, his *Venetian Funeral*, shown last summer at the Academy and reproduced in *THE STUDIO*. The subject, sombre in its suggestion, depended not at all upon the particular facial expression of any figure or upon any incident pertaining to one figure—a condition upon which a lesser artist would have depended. The spirit of the thing wholly relied upon the line and massing of the composition, and that quality was as strong as was the technical excellence of the painting. So it is with this Venetian subject, so contrary in its meaning to the former one. Here a light musical rhythm pervades the whole composition, each figure or



"AGRICULTURAL LABOURERS"

BY FRANK BRANGWYN, A.R.A.

## Mr. Brangwyn's *Decorative Panels at Venice*

object in perfect harmony with the fantastic spirit of such a subject, and one cannot but feel as he looks at this composition the fine musical quality of the whole. If Whistler has in his "symphonies" shown to the world how great is the musical quality possessed by harmonious colour, then Brangwyn has in his turn shown clearly how much actual music may be expressed by the juxtaposition of line and mass as well as by colour.

The *Venetian Serenaders* has been painted in an unusually short range of actual pigments, yet the picture possesses no less variety of colour than would a mediæval group of Spanish troubadours. In the low violet-blue tone of evening the artist has made the figures exist with the same degree of reality as though seen in bright sunlight. The lanterns, twice the natural size, are indeed real, and have been most cleverly used as telling spots in the long composition. This panel measures eighteen feet long by five feet high, and the difficulties in keeping such a composition in "one piece of tone" will be appreciated by the decorative painter, but here in this large canvas occurs the same tuneful

quality as one might find in his small painted sketch. As a decoration it possesses, perhaps, less actual support to surrounding architecture than do the remaining three, but it is an excellent rendering, in a decorative manner, of the subject in hand.

The panel corresponding to the one just mentioned, *Venetian Commerce*, treats of a more serious work-a-day side of these poetic people. So much is there in Venice of the past to fascinate one, that to the casual observer nothing modern suggests itself. But when one pauses to reflect that it is still a great city, that it must be fed and clothed, and that it has all the commonplace problems of every other city, he then begins to see the serious incidents pertaining to modern Venetian life. The heavy barques take the place of wagons in other cities—and just as the sleepy carman comes through London's West End with his absurdly enormous loads, so does the gondolier glide noiselessly over Venice's dark lagoons. Within his heavily laden "barco" his movement is slow and ponderous, like the heavy pulling of a beast of burden. This work-a-day life forms the subject of



"STEEL WORKERS"

BY FRANK BRANGWYN, A.R.A.





SKETCHES FOR VENETIAN PANEL. BY FRANK BRANGWYN, A.R.A.



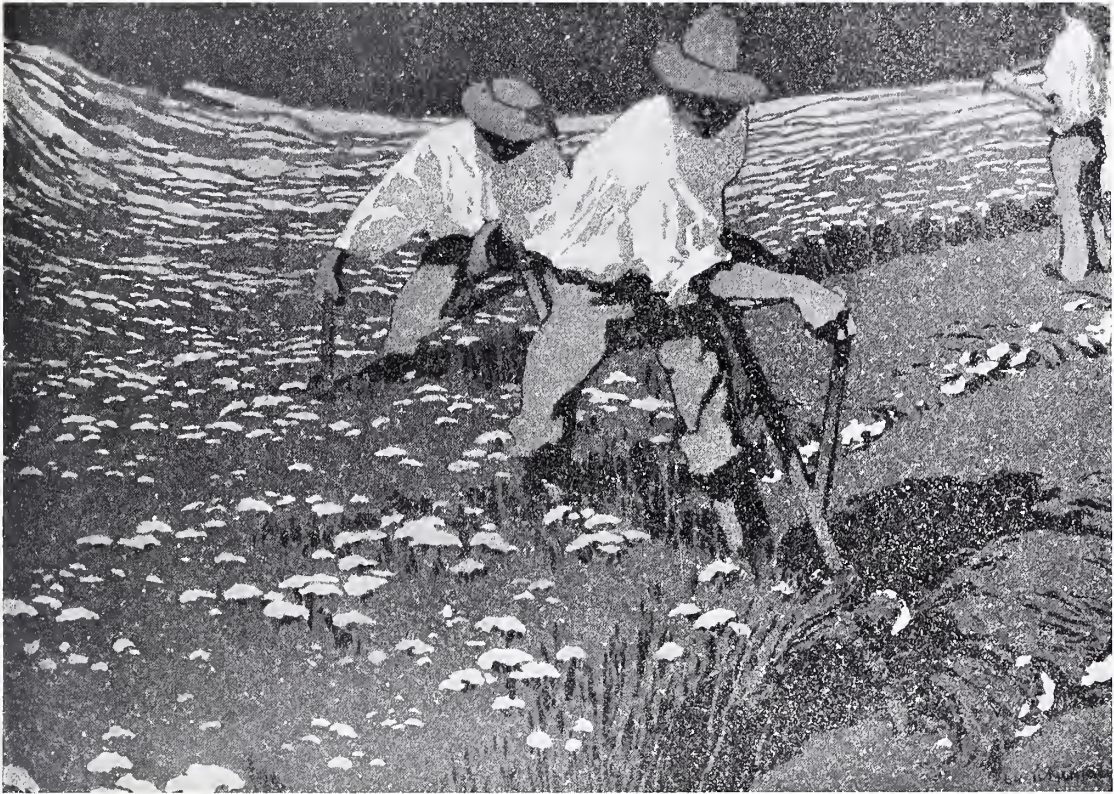

"THE MOWERS" (COLOURED STENCIL DRAWING)

BY LUDWIG JUNGNICHEL

the panel. He has chosen some figures in the act of loading and unloading boats laden with wine, vegetables, and fruits. In this I find a strong pattern which in its largeness of masses would support the heaviest of architecture with sufficient incident and minor notes to prevent the whole thing from being cumbersome.

The two remaining subjects, which treat of British subjects, occupy positions at either end of the room, and are much smaller than the Venetian compositions. This change in the character of the *motifs* is not so apparent as the colour scheme, and the decorative treatment is quite similar in the whole set.

The two subjects *Steel Workers* and *Agricultural Labourers* are not new to Mr. Brangwyn, but in the latter he seems to me to strike a new note. Four figures are seen picking cabbages in the cool grey light of early morning. A mist seems to envelop them, giving the whole a sense of reality which is most refreshing, at the same time taking its place in perfect harmony with the remaining panels. The *Steel Workers* is painted in the same scheme of greyish-blue and gold. Two half-nude figures are seen pushing a truckload of ore, and the power suggested is tremendous, emphasised by the line and the arrangement of masses in the composition,

which as I have before suggested always does more towards bringing out the spirit of the thing in a Brangwyn composition than does any incident or incidents occurring in the picture.

These elements are without doubt the most personal in all the phases of the work of this versatile artist, and I believe that most painters and sculptors will agree that they are the most powerful means placed in the hands of the artist.

The pictures shown in the British room are representative, and the number has been kept in proportion to the space allotted, considerable wall space being given to each picture. The English visitor at the Venice Exhibition this summer should be gratified not only at the excellence of the work shown, but the tasteful manner in which the pictures have been hung, as well as by the fine aspect which the room itself presents.

ARTHUR S. COVEY.

## THE COLOURED STENCIL DRAWINGS OF LUDWIG JUNGNICHEL.

IN a recent number of *THE STUDIO*, a brief account was given of the Imperial Arts and Crafts Schools (*Kunstgewerbeschulen*) at Vienna, and in

## L. Jungnickel's Coloured Stencil Drawings



COLOURED STENCIL DRAWING

BY LUDWIG JUNGNICHEL

the course of it reference was made to the progress accomplished in the graphic and decorative arts under the new *régime* initiated by Baron Myrbach. To him and his able coadjutor, Prof. Roller, is largely due that vigorous development in the various branches of graphic art which has placed Vienna on an equality with other great art centres in Europe—if indeed she has not outpaced them

in certain directions. Be that as it may, there have gone forth from these schools, and are still going forth, a generation of young men and women who are filled with a genuine feeling for art and by their subsequent achievements have added greatly to the prestige of the schools. One such is Ludwig Jungnickel, a young artist whose undoubted originality has manifested itself especially in stencil compositions of diverse kinds, and his work in this direction is so far out of the common as to justify notice here.

Jungnickel, who is a native of Munich, was attracted to Vienna by the fame of the Kunstgewerbeschulen and the reputation which Prof. Roller especially had acquired as a teacher. At Munich he studied drawing at the evening classes held at the Gewerbeschule (Artizans' School), contrary to the wishes of his relatives and friends, but being bent on becoming an artist by profession he joined the School of Arts and Crafts there. He soon gave this up, however, and, notwithstanding financial and other obstacles, made his way to Rome, where he got a living by copying pictures, and was so enabled to save sufficient to migrate to Vienna. Joining the Arts and Crafts Schools he found in Prof. Roller a teacher after his own mind. It was one of Prof. Roller's



"THE TENNIS PLAYERS" (COLOURED STENCIL DRAWING)

BY LUDWIG JUNGNICHEL



STENCIL LANDSCAPE. BY LUDWIG JUNGNICKEL.



COLOURED STENCIL DRAWING

BY LUDWIG JUNGNICHEL

in certain directions. Be that as it may, there have gone forth from these schools, and are still going forth, a generation of young men and women who are filled with a genuine feeling for art and by their subsequent achievements have added greatly to the prestige of the schools. One such is Ludwig Jungnickel, a young artist whose undoubted originality has manifested itself especially in stencil compositions of diverse kinds, and his work in this direction is so far out of the common as to justify notice here.

Jungnickel, who is a native of Munich, was attracted to Vienna by the fame of the Kunstgewerbeschulen and the reputation which Prof. Roller especially had acquired as a teacher. At Munich he studied drawing at the evening classes held at the Gewerbeschule (Artizans' School), contrary to the wishes of his relatives and friends, but being bent on becoming

the course of his education was made to the progress accomplished in the graphic and decorative arts under the new system initiated by Baron Myrbach. To him and his able coadjutor, Prof. Roller, is largely due the vigorous development in the various branches of graphic art which has placed Vienna on a par with other great art centres in Europe. Indeed she has not outpaced them

an artist by profession he joined the School of Arts and Crafts there. He soon gave this up, however, and, notwithstanding financial and other obstacles, made his way to Rome, where he got a living by copying pictures, and was so enabled to save sufficient to migrate to Vienna. Joining the Arts and Crafts Schools he found in Prof. Roller a teacher after his own mind. It was one of Prof. Roller's



"THE TENNIS GAME" (COLOURED STENCIL DRAWING)

BY LUDWIG JUNGNICHEL



STENCIL LANDSCAPE. BY LUDWIG JUNGNICHEL.





## L. Jungnickel's Coloured Stencil Drawings



COLOURED STENCIL DRAWING

BY LUDWIG JUNGNICHEL

merits (he is no longer a professor at these schools, having been appointed to an important post at the Imperial Opera House) that he was able to infuse a spirit of enthusiasm for work into his students, and to rouse them to independent thought. From him Jungnickel learnt the value of a trained memory, and the importance of cultivating habits of observation. Nor was he slow to profit by the professor's teaching. Directed to nature as the true source of inspiration, he applied himself assiduously to the study of animals both in motion and at rest, and thus familiarised himself with all their ways and aspects, and in this way laid a sure foundation for that technical ability which has contributed so much to his success. Prof. Roller, moreover, discouraged mere passive receptivity on the part of his students; on the contrary, he always encouraged them to express themselves in their own way, to find out and put in practice new methods irrespective of what they had been taught—in short, to stimulate their individuality. By this means, and by the candid and convincing criticism to

which he subjected their work, he has been instrumental in leading many a young student along the rugged path by which more or less complete self-reliance is attained. Jungnickel is among a considerable number of others who have reached this goal. Experience has taught him that complicated methods are not always essential to a good final result, but that simple methods may, with due discrimination, give far better results. For the stencil work in which he has specialised all the material required is cardboard, paper, a sharp knife, a stock of colours, a syringe, and a wire screen. The process he employs, however, is one demanding a considerable concentration of thought; and unlimited patience is necessary as well as artistic ability. Only by continual practice, and after many failures,

can the requisite deftness of manipulation be acquired.

These coloured stencil drawings of Jungnickel's have been taken at first sight for lithographic prints. This is due to the peculiar nature of the technique, which is an invention of his own. A brief explanation of this may be of interest. Part of the process is that which is pursued in stencil work generally. Using cardboard for his plates, the design is cut out with a sharp knife. The next step is to prepare the paper on which the complete design is to be painted by giving it the desired

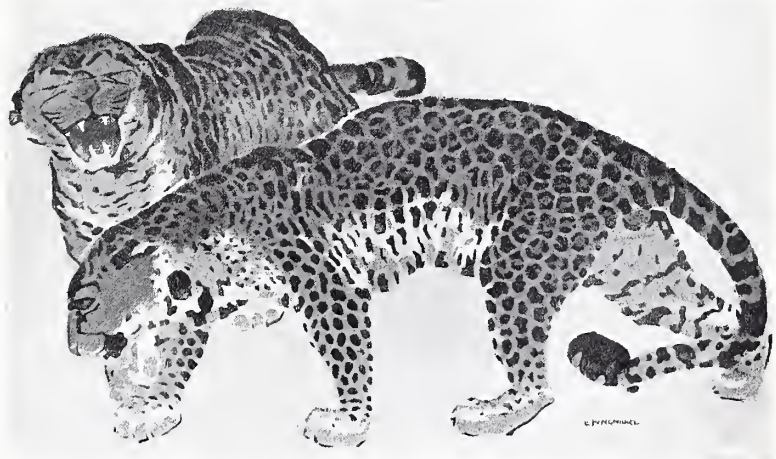

COLOURED STENCIL DRAWING

BY LUDWIG JUNGNICHEL

## L. Jungnickel's Coloured Stencil Drawings

ground tone. This Jungnickel does by squirting all over it the colour selected (in a thin state), using for the purpose a syringe working from behind a wire screen. Ejected in this way, the colour falls on the paper in minute particles; the paper assumes a rough granulated appearance, and as the particles are never uniform but take various forms, a considerable variation of pleasing effects can be produced. When the ground tone has thoroughly dried the next step is taken. The cardboard stencil is laid upon the paper and the syringe again does its work, but always from behind the wire screen. The particles vary according to the consistency of the colour used and according to the distance at which the screen is held. Further effects are obtained by varying the size of the syringe, the particles falling on the paper being larger or smaller according to whether a short thick one or a long fine one is used. When it is desired that one tone should blend into another the second "coating" is put on before the first one is quite dry. This causes the particles to run together, and in this manner some beautiful soft tones may be obtained. For the delicate soft

tones the colour must have more consistency than for the harder ones.

The difficulties encountered in this process are, of course, many. It is not every picture that turns out well; manipulative skill alone is not enough, and unless Jungnickel feels that his work is really true and artistic in every sense of the word he does not show it. Notwithstanding this, the variety of his stencil plates is considerable. In some—as, for instance, his studies of flamingoes—there is a great amount of very intricate work, while in other cases—as those of his drawings of panthers, leopards, kittens, etc.—the treatment is comparatively broad (the accompanying illustrations of these animals have been reproduced from large drawings). He has, however, essayed more complex pictorial compositions—as witness the landscapes of which coloured reproductions accompany these notes, and an effective harvest picture, called *The Mowers*, in which five stencil plates were used. He never, however, attempts to overstep the legitimate boundaries of his peculiar technique—he is well aware that it has boundaries, and that is an important thing to know.

A. S. L.

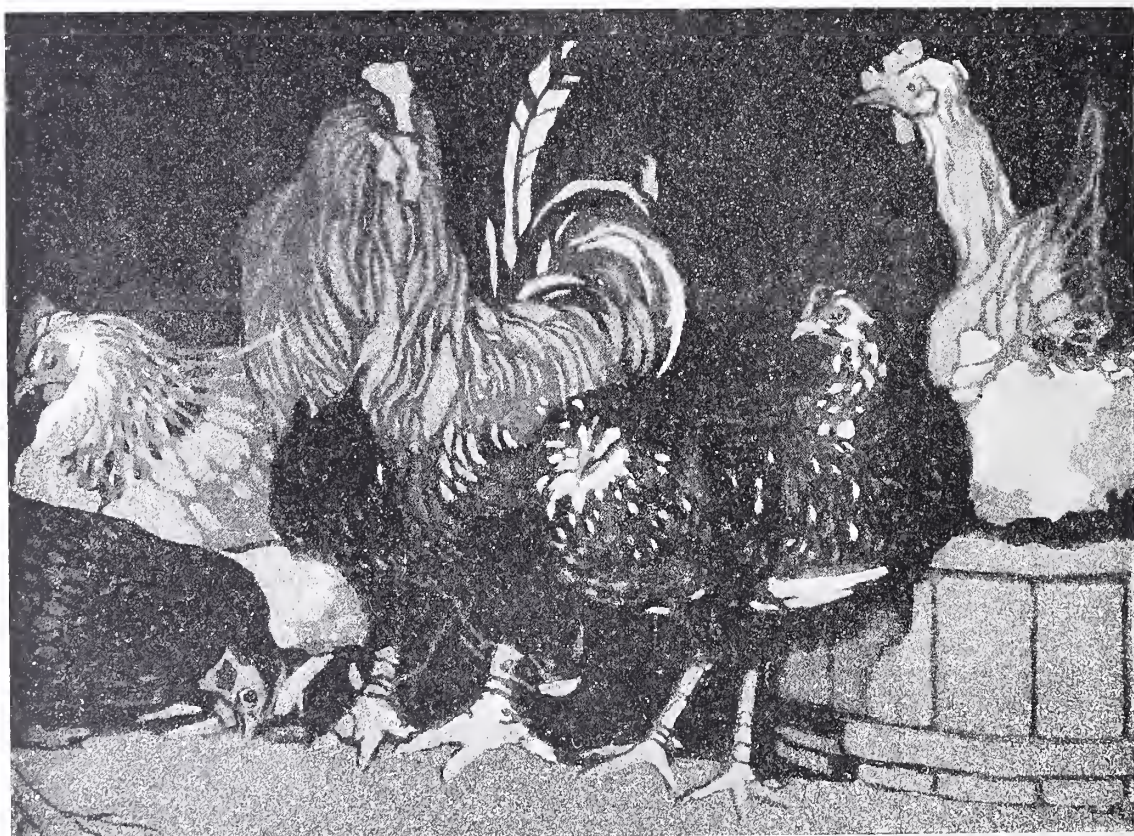

COLOURED STENCIL DRAWING

BY LUDWIG JUNGNICHEL



STENCIL LANDSCAPE. BY LUDWIG JUNGNICKEL.



## The Royal Academy, 1907

### THE ROYAL ACADEMY EXHIBITION, 1907.

THERE have been more uninteresting exhibitions at the Royal Academy than the present one. This is not a year when a few large pictures stand out absorbing our attention. The merits of this exhibition are far scattered in a multitude of pictures of unobtrusive size. There is plenty of outside, unacademic effort admitted, and this is the interesting point this year. It follows the election to associateship of painters representative of outside movement. The Academy is entitled to sincere congratulations on this broadening policy, but still there remain on the walls pictures at which one looks wondering how they come to be there. The Academy is apparently not quite willing yet to make a determined effort to get rid of the catch-shilling element and devote itself wholly to encouragement of art.

Among the Academicians, Sir Lawrence Alma Tadema, Mr. E. A. Abbey, and Mr. Marcus Stone do not exhibit this year, but Mr. Brangwyn is the sole absentee among the Associates.

Mr. Sargent's genius predominates in three of the rooms, in single portraits of *Lady Eden*, *Lady Speyer*, *Lady Sassoon*, *Mrs. Archibald Langman*, and *The Countess of Essex*. It is not often so thoughtful a face as that in the portrait of Mrs. Langman looks out from a canvas by Mr. Sargent. The spirit of his art is too much a part of the age which has invented the phrase "the strenuous life," using it as a motto. Other painters have qualities which Mr. Sargent has not, but one has to forget his matchless craft and all the thousand subtleties upon which it depends before one can turn responsively to styles of painting engendered by other habits of thought and vision. Besides Mr. Sargent's work the portraits of Mr. Orchardson as usual prove one of the chief features of the Academy, his *Thomas Carlaw Martin, Esq., LL.D.* (Editor of the "Dundee Advertiser"), being especially notable. Sir Luke Fildes, too, has devoted his art entirely to portraiture this year, and, except for an interesting water-colour, it is by portraiture that Professor Herkomer has chosen to be represented.

Mr. Waterhouse sends two of his subject pictures. It is always the sense of beauty that proclaims itself in Mr. Waterhouse's art, making it so definitely attractive. This sense with him is creative rather than interpretive. He probably would not deny the literary character of his art, in which flowers and faces and the colour of draperies are given as symbols to create thought of beauty as

literature creates it. Mr. Seymour Lucas, who is never more skilful than in his smaller *genre* subjects, has added to them *The Roundelay*, one of the most attractive.

Of landscape work by members, the work of Mr. David Murray stands readily to the front. He has rarely been more interesting than in his picture *The Windmill*. It is a painting full of incident, and the utmost ingenuity has been displayed in the difficult composition. His picture *Across the River* is not less interesting. Neither *The Duet* nor *Wistaria* by the same artist bear comparison with these. The delightful quiet and distinction of Sir Ernest Waterlow's art are to be seen to advantage in more than one canvas, but chiefly in *A Chalk Pit on the Sussex Downs*, with its white cliff and delicate green country and the carefully painted blue distance—a blue of nature and not of the palette.

In the matter of landscapes the associates are strong—indeed, it is due to them perhaps that it is so good a landscape year. One includes as landscape, for the convenience of writing, such a picture as Mr. Clausen's *Building the Rick*, which perhaps, with *The Little Brook*, represents his powers at their best. Nature is seen in just such a bright and coloured way in Mr. Clausen's art as the reflections in a crystal take to themselves; sometimes he scarcely escapes artificiality. A red spot of sun on the harness burns like a spot of sun reflected from glass, but no one has perhaps reached so closely the interpretation of heat and light. Time, we think, will touch very gracefully these pictures, so that years hence their colours will burn with a more restrained beauty. The *Sussex Stream* of Mr. La Thangue is a very naturalistic painting, embracing many difficult problems. Each difficult detail has been accounted for with brilliant success, but one wonders that the sunlight does not seem bright on the fields and cattle, as is evidently intended from the shadows on the figures. The painting is a remarkable achievement, but as the artist is known to carry out his subjects out of doors and direct from nature, one expects to receive conviction of truth in such a matter as we have just mentioned. Mr. Alfred East, in *The Aftermath*, paints a quiet, flat, green stretch of country very refreshingly; the indication of the cut hay, the naturalistic colour, the finely-treated sky, and the dignity of the tree painting are remarkable, though differing from the partly decorative ideal which most often controls Mr. East's compositions and is seen to advantage in *Old Durham*. Here the dark figures and masses of golden-brown trees show the habit of this painter in looking

## The Royal Academy, 1907

for the occurrence in life of incidents which suggest romantic composition. The canvas called *Noon*, by Mr. Arnesby Brown, in which some cattle are drawn up in the wide shadow of a large tree, is painted with original and pleasant realism. *The Wherry* is also a fine picture by the same painter. Mr. Stanhope Forbes has painted Newlyn again, pushing his art a little further along the lines which long ago he had chosen. Mr. J. W. North's *Ye Valleys Low*, except for some unpleasant brown shadows to which we might take exception, is a true rendering of valley mist creeping through the trees. *The Off-Shore Wind* is one of the best sea pieces Mr. Napier Hemy has done. In this case he depends on scarcely anything to interest us but the rendering of the sea. In his *Bound for London* he turns his face landward, and attacks the difficulties of the line of houses upon the river bank successfully.

In portraiture and other figure subjects the associates are also very successful. Mr. Cope's portrait of His Majesty the King is one of the most successful Royal portraits which has been painted for a number of years. Mr. George Henry's picture *In the Mirror* is a singularly accomplished painting. The scheme is white graduating delicately to grey, and valuable notes of colour are given with the black closed fan which the lady holds and some mysteriously beautiful red reflections in the gilt mirror. A green porcelain bowl of daffodils makes another pleasure for the eye. It is when Mr. Henry shows his fastidious taste in thinking out these harmonies, which depend almost upon the colour of trifles for their success, that he is at his best. Quite a different way of arriving at beauty is displayed by Mr. Strang. It is a very difficult way. In his love for colour Mr. Strang puts a red, which partakes of the beauty of the colour of the Venetians, against a blue or a green no less separately beautiful and pleasurable to the eye, but when they are all three together they somehow seem often to rob beauty of each other by their sharp contrast, and spoil the effect in the picture as a whole. The art of Mr. Edward Stott, with its conscious effort at sentiment not only in the subject but in the rendering of it, has attained this year in *The Reaper and the Maid* and *The Cottage Madonna* all the harmony of colour which is the feature of his finest work.

Among the more interesting pictures from outside the ranks of members and associates, Mr. G. W. Lambert's large *Portrait Group* attracts immediate attention. Attention to details is given in a broad manner, and it is perhaps where this atten-

tion is shown that the painting is best, but in the transition from deliberate to summary treatment which is made in different parts of the canvas, and the acceptance of naturalistic motives only to subject them to decorative restraint, the artist shows an indecision of purpose from which we should be glad to see him escape. He robs his figures of the spontaneity of that which is accepted frankly from nature; the people who sit for him seem self-conscious as they surrender to the pose chosen for them. Still we are conscious that here a painter of original thoughts is evolving in a very interesting if roundabout way. The atmospheric picture called *Clapham Church* of Mr. Buxton Knight is another very interesting work from outside. It is full of the restlessness of a certain kind of fine weather in England, and the painting is quite masterly.

Mr. Mark Fisher's *Meadows* is a good example of his art in its present manner. As far as one could see at the distance at which it was away, the picture by Mr. Arnold Priestman or *Littlehampton Quay* is one which deserved to be hung much lower down. Mr. Robert W. Allan's *Arriving Home*, with its clear blue sunlit sea and dark-sailed fishing boats, is admirable. Another seapiece of great merit is *The Lizard*, of Hon. Duff Tollemache. Mr. Walter Donne's *From the Battlements of Windsor Castle* is an interesting landscape of the topographical kind, though if the view is, as we imagine, taken as it stands now, modern buildings and all, one wonders why the sightseers on the battlement are put into crinolines and poke bonnets. *A September Morning* is just one of those delicate pictures with the sunlight in them which Mr. Arthur Friedenson is teaching us to look for with pleasure from his brush. But for the vividness of the shot-silk dress the portrait of *Mrs. Young Hunter*, by her husband, would be a very excellent painting. A dramatic picture, which doubtless is a popular one with the general public, is Mr. F. Cadogan Cowper's scene of charitable nuns entertaining the Devil disguised as a troubadour. The painter shows considerable power over dramatic facial expression. The figure of the Devil is slightly confused with the design of the window (one of the famous Fairford windows we believe) which forms its background, but there may be metaphor in this. *A Flemish Peasant*, by Walter Langley, is notably a work of confidence and simplicity in technique. Mons. J. E. Blanche is not seen to such advantage here in his portrait of *Miss B. Cabel* as he was in the recent International Exhibition. *The Firelight and Pearl* of Mr. Walter West, whilst charming in its drawing is



*(An autogravure plate of this picture is being published by the Autotype Co., 74 New Oxford St.)*

HIS MAJESTY THE KING  
BY A. S. COPE, A.R.A.



BRONZE STATUETTE: "INSPIRATION"  
 BY ALFRED DRURY, A.R.A.  
 (Study for Statue for principal entrance,  
 Victoria and Albert Museum)

not pleasant in colour effect, which surely is the *raison d'être* for flooding a picture in these red-brown tones. His dainty talent is far happier in *Sweetness and Light*. Mr. Harrington Mann exhibits a portrait of great success in *A Little Girl with Dolls*. Miss Constance Halford in a picture called *In Summer Time* shows feeling for effect of drapery painted from a frankly fanciful point of view. The *Ballerina* of Mr. Melton Fisher reveals the swift and certain skill of high accomplishment, though we are not attracted by the colour.

Last year Mr. Frank Craig's picture was bought with the Chantrey Fund. His picture this year, *The Maid*, is larger though not different in style. Mr. Craig is the acknowledged successor to Mr. Abbey, and like Mr. Abbey he has made a reputation in

illustration. The faults of this work are those of its type. The endeavour to arrive at a decorative scheme of strong colours makes the artist leave atmosphere out of the question, so we find the shafts in this picture, near and far away, all the same tone. The treatment of the central figure under the unfurled banner, is certainly of high decorative order. Mr. Gerald Moira returns in *Zephyr and Aurora* to a class of subject in which he made his reputation, and shows in it those faculties, which are so peculiarly his, of conceiving vividly a poetic conception and giving it shape in the form of true decoration. *An Early Victorian* by Mr. William Logsdail is full of excellent modelling and craftsmanship, and compels attention by the high-water mark of its skill.

(Continued on page 49.)



BRONZE STATUETTE: "KNOWLEDGE"  
 BY ALFRED DRURY, A.R.A.  
 (Companion to "Inspiration")





*(Model for Bronze Statue  
erected at Hatfield)*

THE LATE MARQUÈSS OF SALISBURY  
BY GEORGE FRAMPTON, R.A.



“NOON.” BY ARNESBY BROWN, A.R.A.



*(Purchased under the terms  
of the Chantry Bequest)*

“THE REHEARSAL.” BY  
L. CAMPBELL TAYLOR

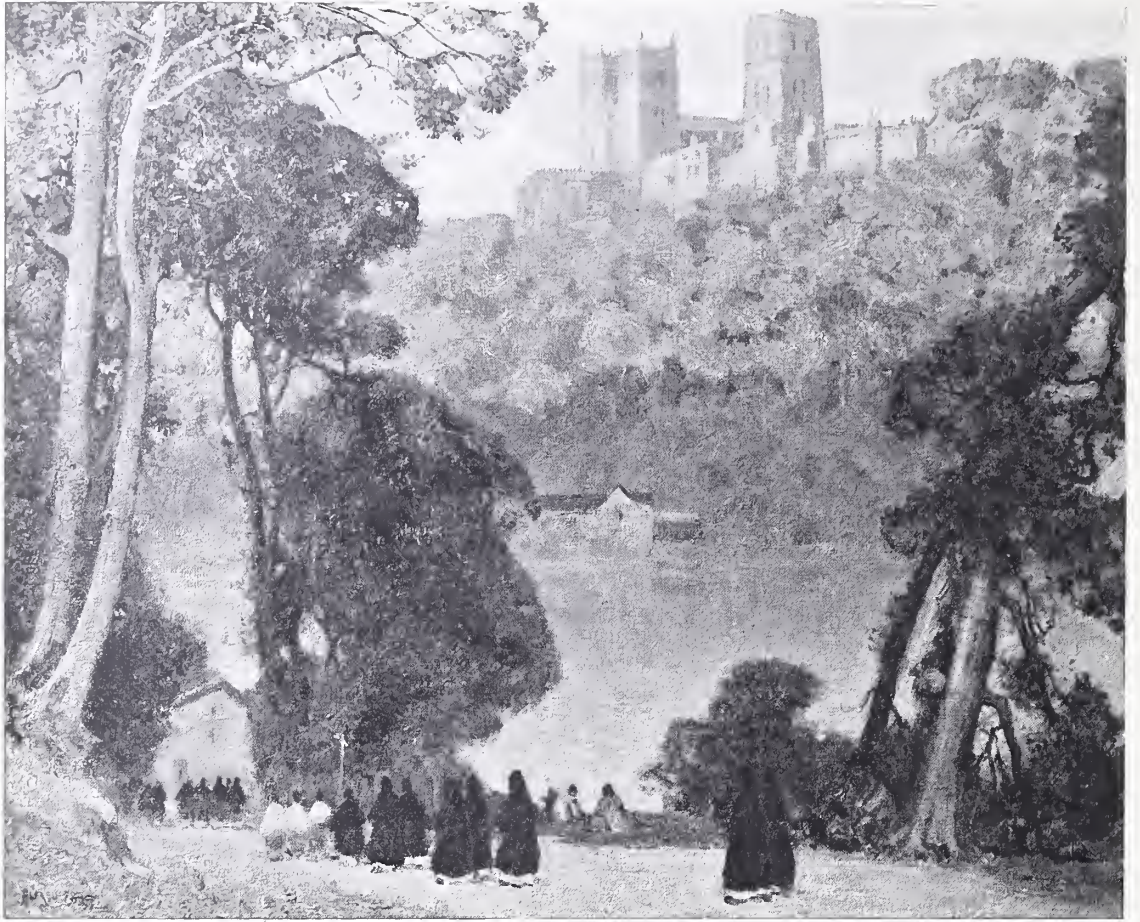

“OLD DURHAM.” BY  
ALFRED EAST, A.R.A.



STUDY FOR PHYLLIS ("PHYLLIS AND DEMOPHOON"),  
BY J. W. WATERHOUSE, R.A.





"A COTTAGE MADONNA"  
BY EDWARD STOTT, A.R.A.



"ACROSS THE RIVER"  
BY DAVID MURRAY, R.A.





"A ROUNDELAY." BY  
SEYMOUR LUCAS, R.A.

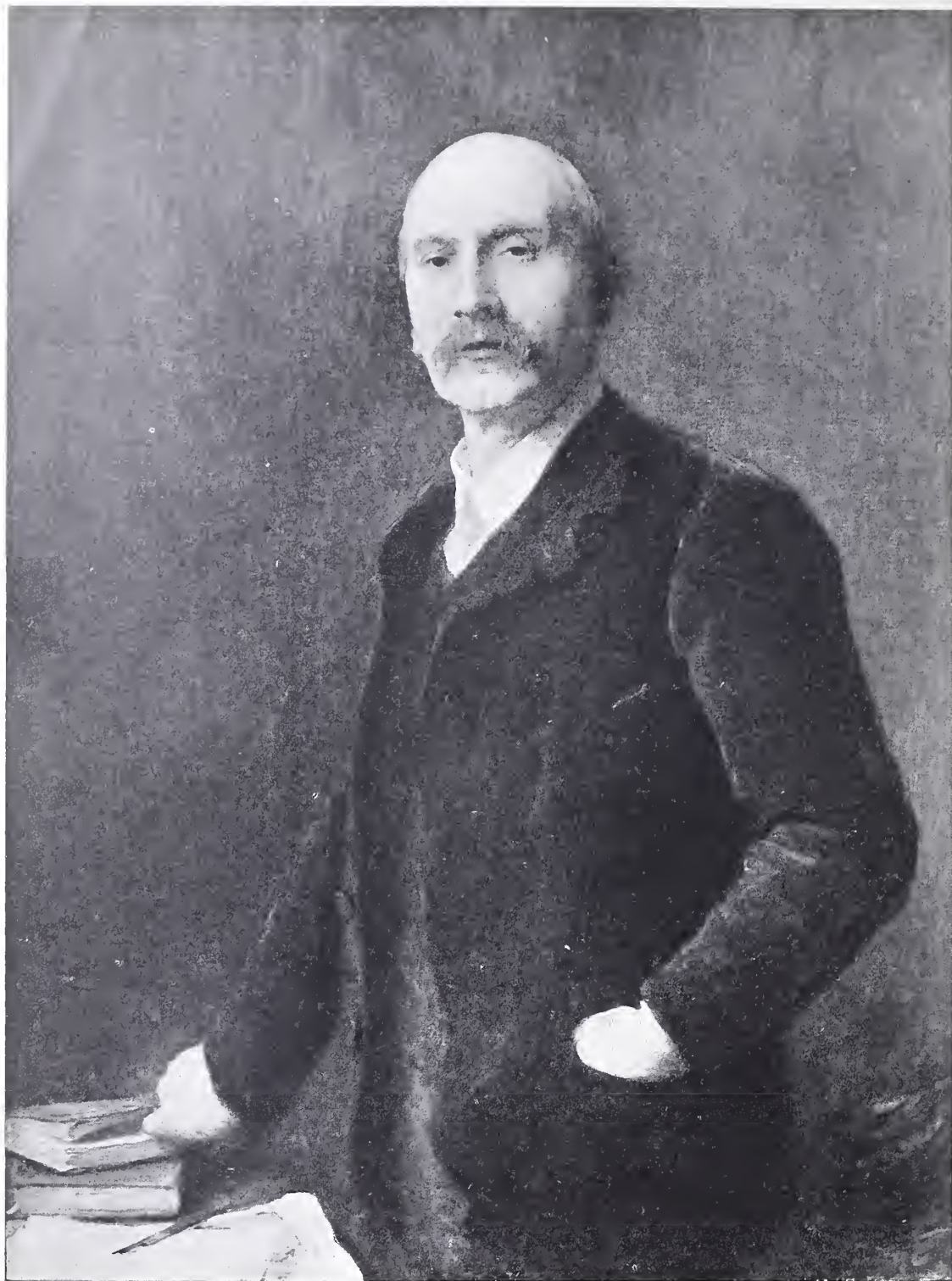

THOMAS CARLAW MARTIN, ESQ., LL.D.  
BY W. Q. ORCHARDSON, R.A.

*(Photo: Lowden & Son)*



"THE SKYLARK." BY  
ARTHUR HACKER, A.R.A



“ZEPHYR AND AURORA”  
BY GERALD MOIRA



*(By permission of Messrs.  
Thos. Agnew & Sons)*

“THE LITTLE BROOK.” BY  
GEORGE CLAUSEN, A.R.A.



“BOUND FOR LONDON: GULLS FLYING UP  
THE RIVER.” BY C. NAPIER HEMY, A.R.A.



"THE PEARLS OF APHRODITE  
BY HERBERT DRAPER

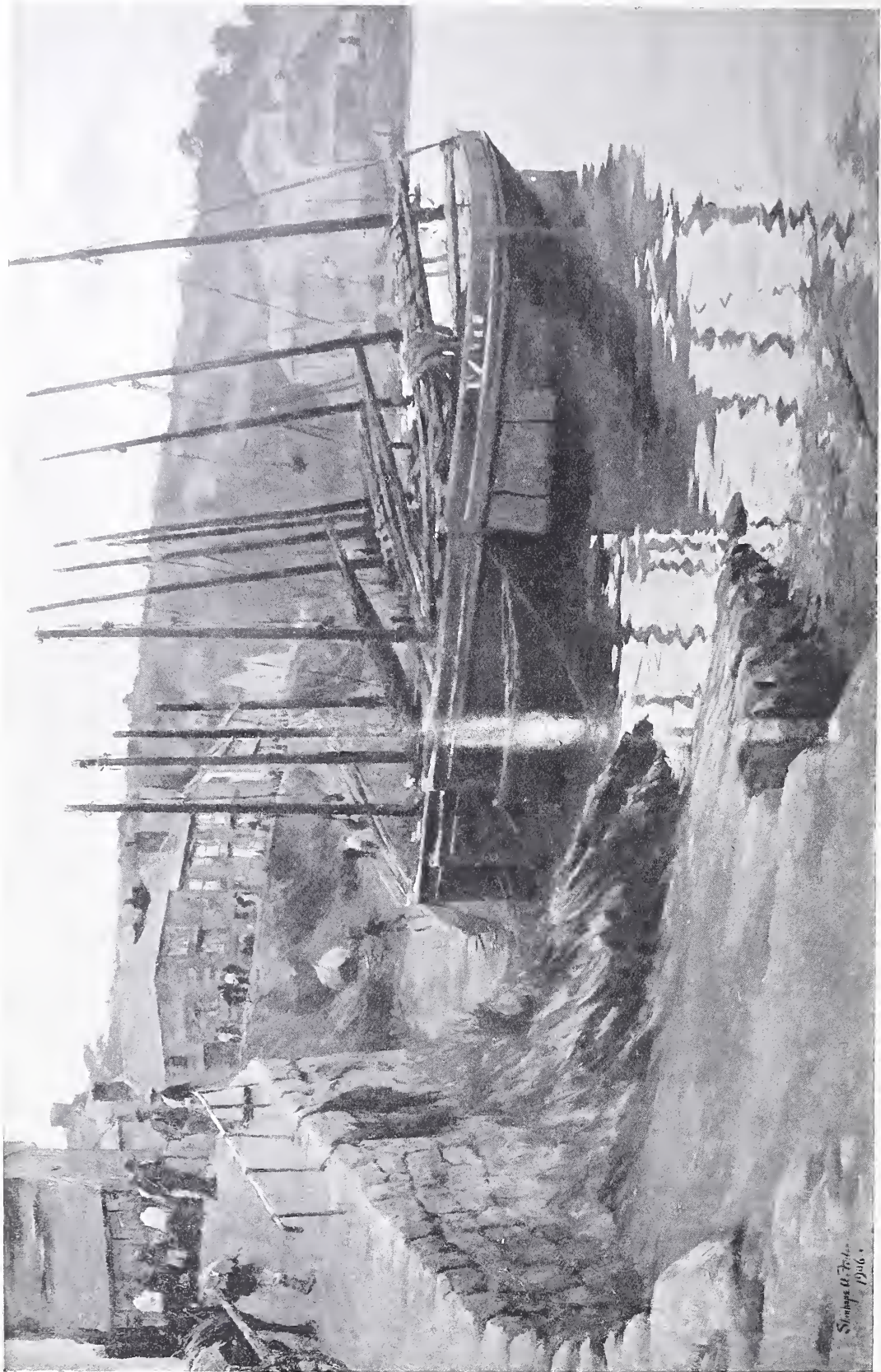

“AT THEIR MOORINGS.” BY  
STANHOPE A. FORBES, A.R.A.

Stanhope A. Forbes.  
1906.



## The Royal Academy, 1907

We remember commending a picture by Mr. Campbell Taylor in the last academy, the subject of which was not dissimilar to that taken up here in *The Rehearsal*, one of this year's Chantrey purchases. Mr. Taylor has come from a very small canvas to a very large one. On the larger scale his touch loses somewhat in feeling, but in all other respects this work commends itself as one of the most successful pieces of *genre* painting in this year's exhibition. There is life and sunshine in Miss A. L. Swynnerton's portrait group, *Margaret and Christian, daughters of D. C. Guthrie, Esq.*, but the colour does not advance its merits. An interesting portrait is that of *Mrs. Bowles* by Mr. Mouat Loudan; here many pleasant passages of colour have been contrived, though the face seems too deliberate in the character of the painting for the rest of the picture. Mr. Lee Hankey's *Many the Wonders I have seen* might, we think, have been hung lower down.

Mr. Byam Shaw's *Such is Life* is one of his most interesting canvases. The scene depicted, with its theatrical light, suits better than a scene in the light of nature the particular colours with which Mr. Shaw sets his palette. In a picture named the *Morning Room* Mr. Walter Russell has painted two figures seated in a room into which the full daylight comes. The room is furnished with a tendency to things early Victorian, and a famous wit may be recognised in one of the figures. The luminous painting of the window frames, the couch partly bathed in bright light—in fact, all the painting—is masterly, except in the lady's figure, where the essential note of grace in the fall of the skirt is missing. Whilst he does not vary his style in any degree, Mr. E. A. Hornel ever seems to acquire more accomplishment, and his picture *The Music of the Woods* must certainly rank with his best canvases. Mr. Harold Speed's *Portrait of a Lady* and his *Love leaving Psyche*

are good examples of his scholarly painting. In following lines of older Academic tradition worthily, Mr. Herbert Draper succeeds far better than anyone else in the exhibition.

Of the many pictures which press themselves upon our memory, claiming to be mentioned, space provides us with room for the following only:—*Segovia, Spain*, by M. Hughes - Stanton; *The Avenue*, by W. G. von Glehn, and works by the following:—T. F. M. Sheard, Louis Grier, B. Haughton, A. E. Bottomley, S. P. Kendrick, F. G. Swaish, Anna 'Airy, V. M. Hamilton, M. Cameron, and Dorothea Sharpe.

The sculpture is marked generally by a high level of performance. Members and associates are well represented, Mr. Frampton in particular, by his large statue of the late Marquis of Salisbury, and Mr. Drury by his pair of bronze



“A LITTLE GIRL WITH DOLLS”

BY HARRINGTON MANN

## The New Gallery

statuettes. From outside notable contributions are made by Messrs. Lantéri, Furse, Mackennal, Bayes, Derwent Wood, Conrad Dressler, Lynn Jenkins, Spicer Simpson, Gotto, Taubman, and Reynolds-Stephens, whose *Guinevere's Redeeming* was reproduced in these pages two years ago.

### THE ROYAL SCOTTISH ACADEMY.

THE Spring Number of *THE STUDIO* is especially opportune at the present time, when public attention is directed to Scottish art by the developments which are taking place in connection with the National Gallery of Scotland and the Royal Scottish Academy. Mr. A. L. Baldry has carefully and fully described the growth and development of the Academy from its early struggles down to the present day, when it stands as one of the most important and flourishing art institutions in Great Britain. The volume contains some portraits of prominent artists, and interesting facsimile autograph letters, but its most attractive feature is the splendid series of forty reproductions in facsimile colours made direct from original works by distinguished artists who have been connected with the Academy.

### THE BROTHERS MARIS—JAMES, MATTHEW, WILLIAM.

THE Summer Number of *THE STUDIO* will be ready in a few days, and the subject "The Brothers Maris" is one which will appeal to all who are interested in the higher forms of modern painting. James Maris is universally accepted as one of the most accomplished landscapists the last century produced, and in the rendering of atmospheric effects had no equal since Constable; while Matthew Maris is held by many to be the greatest artist living at the present time. The public have always shown a strong desire to obtain any information regarding this extremely individual painter whose personality seems to be shrouded in mystery. The writer, Mr. D. Croal Thomson (author of "The Barbizon School," etc., etc.), has enjoyed exceptional facilities for obtaining direct from the master himself most interesting details of his career, and the volume will afford a unique opportunity of studying every phase of his subtle art. It will contain numerous illustrations in facsimile colours, photogravure, and other processes, of important examples by each artist, and a facsimile reproduction, personally supervised by the artist, of a study by Matthew Maris, will be amongst the most attractive features of the book, one of the most distinguished and interesting publications ever issued by *THE STUDIO*.

## THE TWENTIETH SUMMER EXHIBITION OF THE NEW GALLERY.

ALTHOUGH there is in the New Gallery this year a very fair proportion of works which are well worth attention, the show as a whole has less than its usual interest. It suffers from that general ineffectiveness which for some time past has been perceptible in most of the larger exhibitions, and it is wanting in freshness and originality. The good things in the collection come almost entirely from men who have accustomed us to expect good work from them, and who keep well up to the average of their accomplishment in previous years; what is lacking is new work by men who are not already established institutions, or who, being well established as exponents of one type of performance, have been inspired to attempt something quite out of their usual direction. In the comparatively recent past the New Gallery was a place where surprises could be expected, where things not ordinarily seen elsewhere had a way of appearing; and now that the gallery has taken upon itself an atmosphere that differs hardly at all from that which habitually pervades the other places where modern pictures and sculpture are exhibited, it seems to have fallen a victim, as they have, to a kind of sleeping sickness. The whole of modern art is affected by this somnolence, and a drowsy inclination to let things stay as they are is one of the most disappointing peculiarities of the artists of the present day.

But perhaps it is a little unreasonable to expect anything else while the condition of the modern art market remains so depressed, and while art patronage continues to be directed by neither taste nor common sense. Artists can hardly help being dull when the people who should encourage them are occupied in a sort of gamble in speculative old masters. So long as buyers would rather spend their money upon questionable canvases in a condition of decay than upon good modern works which are too obviously authentic to be exciting, and so long as patronage is conducted on Stock Exchange lines, the opportunities offered to workers who have the misfortune to be alive will be inevitably scanty, and will assuredly not be such as to induce them to break new ground. On the whole it would seem that we ought to be thankful that the exhibition is no worse; there are some thoroughly sound and sincere productions in it, and with these we must be content.

Among the portraits, the one branch of painting



(By courtesy of the Autotype Co.,  
74 New Oxford Street, W.)

THE REV. EDMOND WARRE, D.D.  
C.B., M.V.O., LATE HEAD-MASTER  
OF ETON. PRESENTATION POR-  
TRAIT BY JOHN S. SARGENT, R.A.

## The New Gallery

which keeps up its vitality, there are several which can be praised without any reservations. Sir George Reid's magnificent character studies of *The Very Rev. Principal Robert H. Story, D.D.*, and *Sir Charles B. Logan, LL.D.*, are wholly acceptable examples of his powers at their best; Mr. W. Logsdail's full length of a lady in black is vigorously handled and has a remarkable degree of vitality; Mr. R. Jack's masculine representation of *Arthur J. Ryle, Esq.*, has real distinction of manner; and Mr. J. J. Shannon's prettily arranged and pleasantly individual portrait study, *The Silver Ship*, is certainly one of the best things he is exhibiting this year. His *Capt. Josceline Bagot* is also to be much commended. Mr. Sargent's large full length of *The Rev. Edmond Warre, D.D.*, is dignified and impressive, and is certainly not lacking in character, and his smaller picture of *Mrs. Harold Harmsworth* is very cleverly painted, though it inclines a little towards prettiness. Of excellent quality, too, are Mr. George Henry's *Mrs. Innes*, Mr. G. Spencer Watson's *Arthur à Beckett Terrell, Esq.*, Mr. W. Llewellyn's *Constance, wife of the Rev. Arthur Luckock*, and *Mollie, Daughter of Campbell S. Holberton, Esq.*, the Hon. John Collier's *Professor Arthur Schuster*, Mr. Harrington Mann's *Kathleen*, Mr. H. Harris Brown's *The Hon. Mrs. Alfred Lyttelton*, and Professor von Herkomer's robust and well understood three-quarter length of *Sir Richard Biddulph Martin*, and there is by Mr. Percy F. S. Spence a portrait of *The Right Hon. John Burns, M.P.*, which takes high rank as an able record of a characteristic type.

The figure pictures of exceptional importance are much less numerous. Sir James Linton's mediæval subject, *The Admonition*, has all his accustomed soundness of method, and is memorable especially for its fine treatment of rich textures. Mr. Harry Becker's episode from the history of the town of Colchester is good in colour and is painted with excellent breadth; Lady Alma-Tadema's *Love at the Mirror* is very charming in its daintiness of senti-

ment and refinement of tone; and Mr. W. Llewellyn's *Confirmation* is quite the most delightful suggestion of the dainty grace of girlhood which he has exhibited for many years. Mr. C. W. Bartlett's *Festival Dance*, Mr. Austen Brown's *At the Window*, Mr. F. M. Skipworth's *The Golden Butterfly* and *The Embroidered Panel*, Mr. F. S. Anderton's *Jessica*, Mr. S. Melton Fisher's delicate little nude, *The Wood Nymph*, and Mr. James Clark's magnificent arrangement of sumptuous colour, *The Sower of the Good Seed*, are all valuable additions to the collection, and there are two decorative panels by Mr. C. E. Hallé which must be noted. The best of the pictures in which figures are combined with landscape are Mr. W. Lee Hankey's admirably painted rustic subjects, *The Goose Girl* and *An Unimportant Task*, the low-toned garden scene, *Perfumed Twilight*, by Mr. Talbot Hughes,



"CONFIRMATION"

BY W. LLEWELLYN

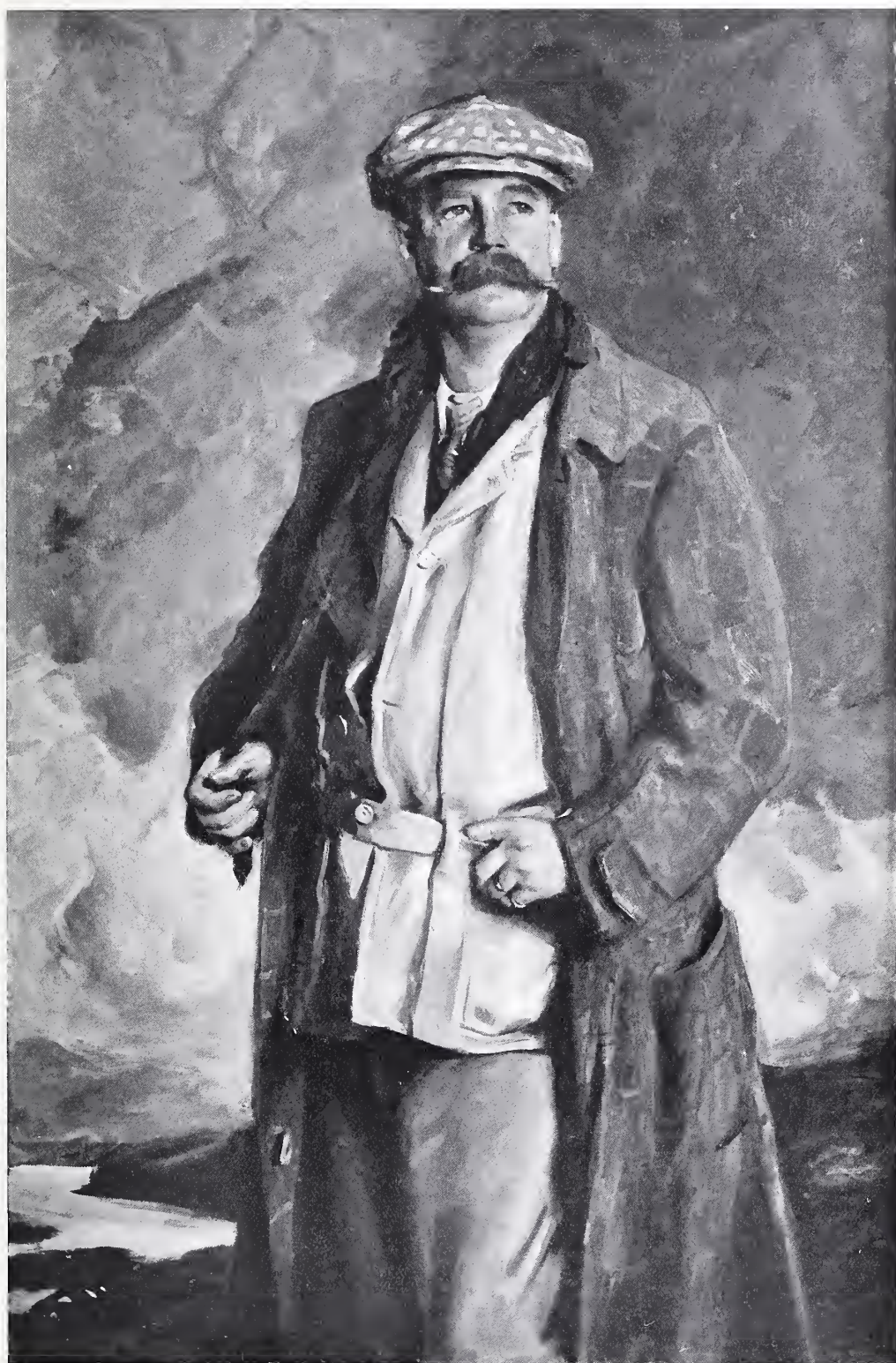

ARTHUR J. RYLE, ESQ.  
BY RICHARD JACK



“THE DIGNITY OF AUTUMN”  
BY ALFRED EAST, A.R.A.



*(Photo. by J. C. Hughes)*

“THE SILVER SHIP.” BY  
J. J. SHANNON, A.R.A.



"THE CHURCH PORCH." BY  
F. SPENLOVE-SPENLOVE





“A FESTIVAL DANCE”  
BY C. W. BARTLETT

*The New Gallery*

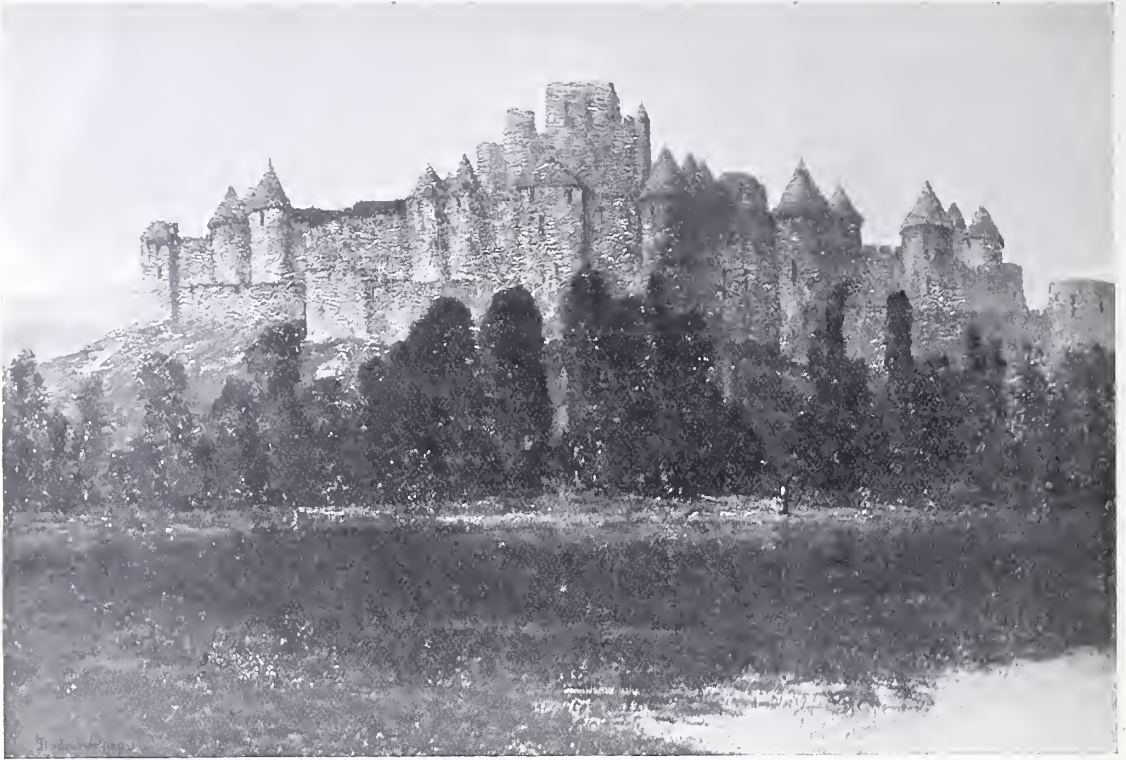

“LA CITÉ DE CARCASSONNE”

BY ISOBEL DODS WITHERS



“THE COURT OF THE OLEANDERS”

BY ALFRED WITHERS

## The New Gallery

Mr. Byam Shaw's *The Caged Bird*, and *The Church Porch*, a well-suggested winter subject by Mr. F. Spenlove Spenlove. Mr. Melton Fisher's *Songs of Araby* is a good record of an effect of lamplight; and the little semi-nude, *Reflections*, by Mr. A. Hitchens, and Mr. St. George Hare's scholarly and sincere picture *A Passing Acquaintance*, are of real importance.

Four landscapes stand out conspicuously among the better things of this class which have been given places in the show. Mr. Alfred East's *The Dignity of Autumn* is one of his finest efforts, splendidly decorative in design and most beautiful in its well balanced arrangement of tones of golden colour; Mr. J. L. Pickering's *Sylvia's Pool*, largely felt and robustly treated, and Mr. J. Coutts Michie's reticent and broadly handled *Among the Silent Hills*, are both admirable in their pictorial qualities, and have the real romanticist sentiment; and the large painting of *The Gorge, Fontainebleau*, by Mr. Hughes-Stanton, is commendably dignified, and is thoroughly sound in its quiet naturalism. Mr. Moffat Lindner's *Amsterdam*, Mr. Montague Smyth's *Hampstead Heath*, Mr. J. Aumonier's *Evening on a Sussex Common*; *The Court of the Oleanders* by Mr. Alfred Withers, and *La Cité de Carcassonne* by Mrs. Dods-Withers; Mr. Ivystan Hetherington's expansive and atmospheric marsh-land landscape, and Mr. Leslie Thomson's luminous *On the Links*, have all particular claims upon the consideration of lovers of nature; and there are two little canvases by Mr. Fred Yates, *Snow at Rydal* and *Snow at Rydal Park*, which, the first one especially, could bear comparison with the works of the greatest masters of landscape. Mr. Yates sees nature with the eye of a poet, but in seeking for poetic expression he does not forget to explain himself through the medium of skilful and purposeful craftsmanship.

There is a little good sculpture, some of which, like the large equestrian figure *Richard Neville, Earl of Warwick*, by Mr. F.

Joubert, is definitely out of the beaten track. The statue, *Lupercalia*, by Mr. Conrad Dressler can be highly praised for its excellence of modelling and for its good suggestion of movement, and Mr. F. Derwent Wood's *Echo*, Mr. Alfred Drury's *St. Michael*, and Mr. Basil Gotto's *A. Chichele Plowden, Esq.*, for their thoroughly accomplished treatment. The symbolical figure *Man and his Burden*, by the late Roscoe Mullins, is impressively conceived and is free from any touch of extravagance. Among the other things in the exhibition which ought not to be overlooked are two architectural studies, one, an amazingly clever sketch, by Mr. Sargent, and the other, the *Gateway of St. John's College, Cambridge*, by Mr. W. Logsdail; a series of illustrative drawings by Mr. H. J. Ford; some crayon portraits by Mr. C. E. Ritchie; the miniatures by Mrs. M. L'ewellyn, Mrs. A. E. Emslie, Mrs.



“ AT THE WINDOW ”

BY T. AUSTEN BROWN



"HOLY GANGES" (ETCHING)

BY M. A. J. BAUER

E. Corbould Ellis, and Mr. Alyn Williams; and the examples of applied art by Miss E. Hallé, Mr. Alexander Fisher, Mr. and Mrs. Arthur Gaskin, and M. Lucien Gaillard. The case of jewellery by this last-named artist is quite fascinating on account of the daintiness of invention and the beauty of workmanship shown in all the things which he has arranged in it. He is a master of this far from unimportant branch of art.

### STUDIO-TALK

(From our Own Correspondents)

**L**ONDON.—At the Royal Academy banquet the Prince of Wales commended India as a field for artists. For those susceptible scarcely any artist can evoke the glamour of the East so well as Mr. M. A. J. Bauer, the perfection of whose art has for long placed him in the front rank of living masters of etching. We reproduce herewith a recent plate entitled *Holy Ganges*, recently on view at Mr. Van Wisselingh's.

The Old Water-Colour Society has always an added interest in its summer exhibition, for it is there that Mr. Sargent exhibits. In *The Vagrant* the touches, which seem at once so careless and inspired, have never brought a face to complete reality and intensity of expression of water-colour. The same skill is at its miraculous play in the *Fountain at Bologna* and the *In a Florentine Villa*. Only Mr. Walter Bayes, perhaps, though on a miniature scale and in a less energetic manner, cares for the same kind of things in the art as Mr. Sargent. Other painters are preoccupied with other aims, for Mr. Sargent's aim has grown out of a strange power and the pleasure of exercising it. Sir Ernest Waterlow, Messrs. R. W. Allan, D. Y. Cameron, and James Paterson, as usual, contribute with distinction. Professor von Herkomer is this time experimental; Mr. E. J. Sullivan is here at his best. Full of a lively interest, Mr. Rackham's drawings, outlined as they are in ink, are less in character with the O.W.S. Exhibitions than water-colours not dependent on this line work, which we

## Studio-Talk

have seen from his brush elsewhere. A noticeable work is Mr. H. S. Hopwood's *Breakfast Table*.

Amongst younger English painters who by their work are rapidly coming into repute, few stand a better chance of attaining distinction than Mr. F. Cadogan Cowper. His is not an unacademic art in these unacademic days; it subscribes largely to the precedents of painting set by the academic school. The expression of an individuality, however, is not a thing necessarily quashed under these conditions: though an art which is personal and strong without eccentricity or over-statement nowadays seems quite rare. His two pictures, *Marianna in the South* and *Patient Griselda*, which we reproduce, were shown at a recent exhibition of the Old Water-Colour Society. Certain qualities of painting in the picture of *Marianna* especially recommended themselves to us, both in the figure and in the very able handling of still-life. We remarked the well-lighted wall on



"MARIANNA IN THE SOUTH" BY F. CADOGAN COWPER

which the mirror hangs, and the treatment accorded to the mirror itself and its reflections.

Mr. H. S. Hopwood, who has been exhibiting at Van Wisselingh's Gallery some oil paintings, is one of the artists whose work, in the words of Whistler, "is finished from the beginning." Every touch seems to have behind it the weight of freshly received impulse, nothing is mechanical, the exact stage at which the artist leaves his picture is, after all, a matter not of the greatest consequence. Whether the work is slight, unpainted to the point of being merely a suggestion, or whether carried to the furthest limits of finish, one is always pleasurably aware that the artist never paints except in his happiest moments.

At Mr. H. Tinson's Gallery Mr. J. H. Jurres, a Dutch artist, has lately exhibited many skilful chalk drawings and oil-paintings, the latter possessing in many cases fine quality of colour. The subjects, chiefly of a biblical nature, were conceived with imagination.



"PATIENT GRISELDA"

BY F. CADOGAN COWPER



THE "LOG CABIN" HOUSEBOAT

DESIGNED BY GEORGE WALTON

Houseboats are for the most part both ugly and inconvenient. Attention to good proportions and harmonious colouring are rarely given, and there can be no doubt that the absence of beauty is a sad fact in connection with the riverside life which with the June weather has launched into full swing. Unique for the reason that the scheme throughout is the product of Mr. George Walton's genius is the "Log Cabin," designed for Mr. Geo. Davison, and now moored adjacent to the Henley Sailing Club boat-house at Wargrave. The "Log Cabin" belongs to that class of houseboat which is constructed with the saloon in the centre, the doorways opening to the side, and the bedrooms and kitchen being at the ends of the boat. An additional boat affording space alongside is almost a necessity with this class of houseboat, and Mr. Walton has devised a fine pontoon for this position. The entire roof is arranged as an



HEADING FOR NOTE-PAPER  
BY G. WALTON

additional deck or room. The iron standards supporting the framing for the green canvas roof are bound together by a flat oak rail about 2 feet 3 inches from the deck, which goes all round this upper floor and serves as a sitting lounge for anyone so disposed. Below the oak rail, canvas wind shields are fastened all round the boat, and the space above from the roof to the deck is closed in with curtains or pinoleum blinds, as shown in the illustration. The sentry-box beehive chairs standing one on each side of

the saloon entrance, are amongst the most ingeniously constructed items on the houseboat. The upper room is furnished with two couches, which serve for sleeping at night when required. There is also a long table for extra big luncheon or dinner parties, and a number of wicker and cane chairs of picturesque design and good construction. The carpet is one of Mr. Walton's many triumphs. The general scheme is a silvery drab



THE "LOG CABIN" HOUSEBOAT

DESIGNED BY GEORGE WALTON

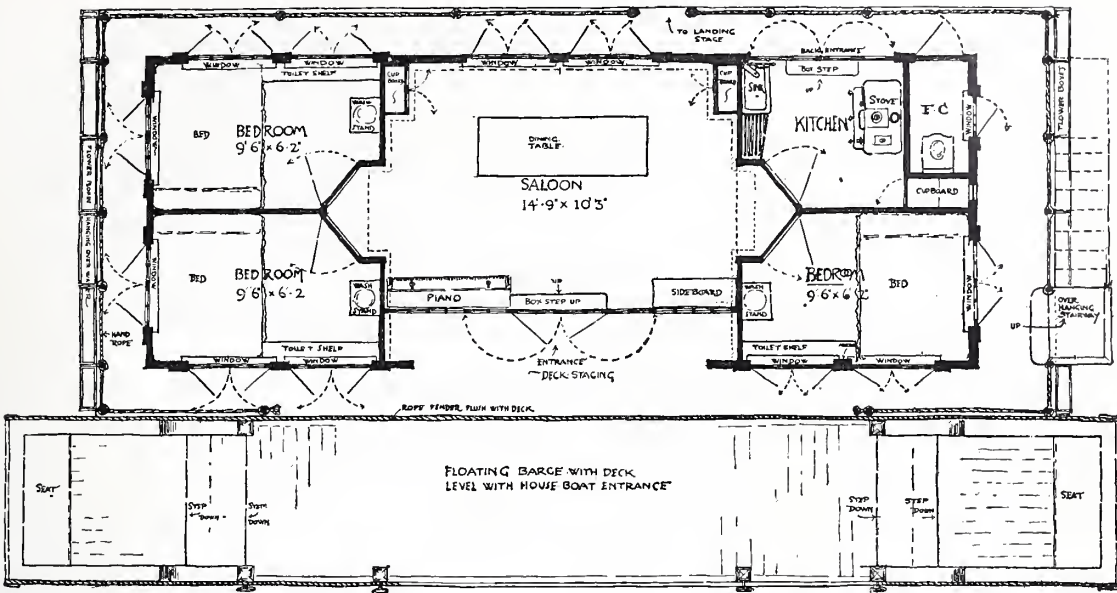

PLAN OF "LOG CABIN" HOUSEBOAT

GEORGE WALTON, ARCHITECT

with a soft velvet effect, the border being an American Indian in his birch-bark canoe in approximately a heliotrope and delicate green colour. The walls of the saloon are a simple but effective wood paneling painted white. The chairs and settees are of ebonised wood with rush seats of the Morris type.

At the Clifford Gallery Mr. Yoshio Markino showed last month a number of delightful drawings under the general title of "The Colour of London." We refer to these drawings in our review of the book published under that title.

Mr. Max Beerbohm's caricatures at the Carfax Gallery have been greeted with enthusiasm, the critic of one influential periodical soothing himself with "their tranquil and tender colour" after a visit to the Academy. We prefer to take them at the value prompted by their own *naïveté*. That much of this *naïveté* is affectation could be seen in the *Lord Tweedmouth*, with its inspiring line. With his quite abstract line, "Max" is the Blake of comedy. It is his gift, with a few lines, to transport his subject to a distance so far removed from all feeling but humour that nothing is kind or cruel.

The water-colours by Mr. H. Hughes-Stanton at the Leicester Galleries showed that artist working in a medium which may be said to be new to him. The style which he has formed in it does

not closely remind us of the note which is so personal in his oils. Apparently he has not discovered yet all the pleasantest qualities of water-colour; this he has done in the case of the oil medium.



THE "LOG CABIN" HOUSEBOAT: DINING SALOON  
DESIGNED BY GEORGE WALTON



LEADED PANEL: "ANGEL OF JUDGMENT" BY WM. GLASBY

Mr. Hughes-Stanton is never happier in these water-colours than in noting the effect upon open country of capricious weather. Mr. Wilfred Ball's agreeable art was represented in an adjoining room with many water-colours of Yorkshire and Warwickshire.

One of the most attractive May exhibitions was that of the Water - Colour Drawings at the Paterson Gallery in Bond Street. Here were many interesting things—Mr. William Nicholson, in his best mood, touching reality with fancy, or fancy with reality—we do not

know quite which—in *The Evening Drive* and *The Mirror*; Mr. Crawhall, subtle and dexterous as ever in his two or three paintings. Here was a strange face, full of haunting meaning, by Mr. James Pryde, drawn with extraordinary power. Mr. Rackham was breaking fresh ground in the purest form of water-colour art. Curiously old-fashioned in feeling was Mr. Orpen in a little pen-drawing, evidently the study for a picture. Messrs. J. M. Swan, R.A., G. Clausen, A.R.A., D. Y. Cameron, altogether more realistic in their aims, were to be seen to great advantage.

In the illustrations we give of some recent work by Mr. William Glasby may perhaps be discerned traces of the influence of Mr. Henry Holiday, with whom he was for a long period associated; at the same time, they are by no means wanting in original feeling. Mr. Glasby pays special attention to the quality of colour,

avoiding both the crudity and timidity often seen in modern windows; and while using the richest colourings he contrives to blend them in such way that the power and joyousness of the colour is maintained.

The Exhibition of The Home Arts and Industries Association, held annually at the Albert Hall, cannot fail to create interest, though to those who hope to find much work possessing artistic merit the exhibition is usually disappointing. Yet it must be admitted that the Association is doing excellent work, and well deserves the encouragement and patronage which it enjoys. We would, however, point out that it is desirable not to invite the Press to view the Exhibition before it is complete, as under such circumstances it is impossible to seriously criticise the work. On the Press day of the Exhibition, held last month, several of the exhibits were not unpacked, while

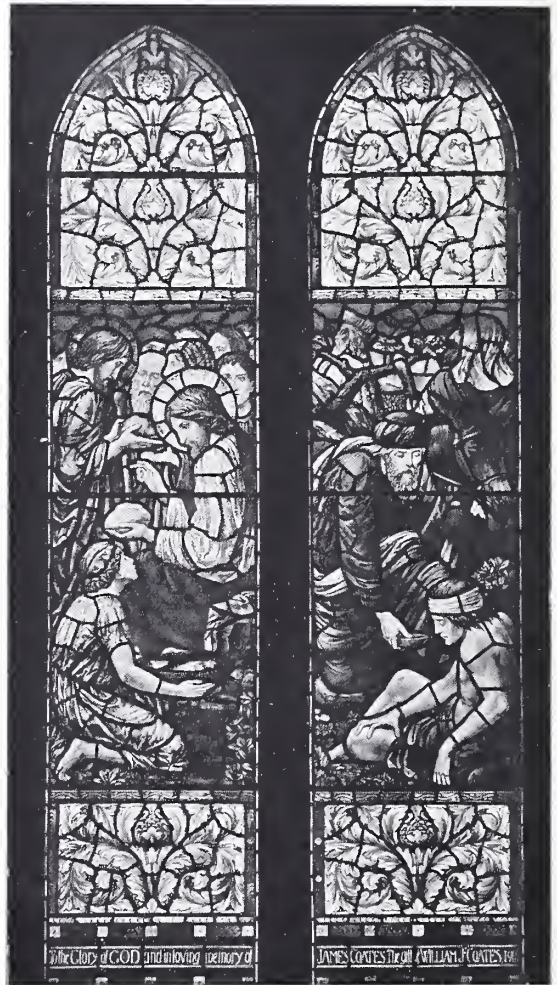

EAST WINDOW, SEREMBAN CHURCH, STRAITS SETTLEMENT BY WM. GLASBY





REREDOS IN LEIGHTON BUZZARD PARISH CHURCH  
DESIGNED BY G. F. BODLEY, R.A.

others were carefully covered over. Amongst the work which could be seen the display of Ruskin pottery (Mr. Howson Taylor) was the most important, while the Compton School, under the direction of Mrs. G. F. Watts, showed some good examples of terra-cotta ware. In our notice of the previous exhibition we had occasion to favourably mention a chest exhibited by the Wilton Industries (Mr. F. A. Rawlence). This year the class sends another excellent piece, the wrought and polished ironwork being good both in design and workmanship.

Some very creditable work has recently been executed by members of the Leighton Buzzard class. The donor of the reredos shown in our illustration stipulated that the manual

work should be done by local craftsmen. The designs were made by Mr. G. F. Bodley, R.A., under whose supervision certain members of the class were entrusted with the wood-carving and with the embossing in leather of the four angels occupying the two doors of the triptych. These figures were embossed in low relief and then silvered and lacquered a gold colour, the drapery and wings being alternately coloured green and red in the four panels. It is believed that this use of leather is practically the first instance in modern times of its application to definitely ecclesiastical



TWO OF THE PANELS SHOWN IN THE ABOVE ILLUSTRATION  
WOOD-CARVING BY H. WIBBERLEY: FIGURES EMBOSSED  
IN LEATHER BY MINNIE KING AND ARTHUR SMALLBONES

decoration, and Mr. Bodley has declared himself satisfied with the result. The wood-carving was done by H. Wibberley, and the leather work by Minnie King and Arthur Smallbones.

At the Dowdeswell Galleries last month Mr. Walter Crane showed an interesting series of water-colours of India and Ceylon made during his recent tour in the East. These drawings, by their dignified simplicity of conception and strength of execution, merited careful consideration. Particularly impressive were the *Snow Peaks of the Himalayas, from Darjeeling*, and *Kinchin-Junga, from Darjeeling—Early Morning*, awe-inspiring in their suggestion of an indefinable solitude. Another striking composition was *The Taj-Mahal*, with the great temple bathed in the pale, weird light of the moon, giving to the scene a sense of the mystery and silence of the night. Amongst other fine achievements we noted *The Maharajah's Palace, Udaipur, After Sunset—Gwalior*, and *The Great Gate of the Temple, Tanjore*.

The International Art Gallery in King William Street was, during May, devoted to the exhibition of the London Sketch Club. Among many noticeable works were pictures by Messrs. Hughes-Stanton, Dudley Hardy, Walter Fowler, Geoffrey Strahan, W. Lee Hankey, René Bull, John Hassall, S. Baghot de la Bere, David Wilson, Lance Thackeray, and sculpture by Messrs. Adrien Jones and Courtenay Pollock.

A small room at the Mendoza Gallery was occupied last month by some admirable water-colours of English flower gardens, the work of Miss Lilian Stannard. The skill displayed in the selection and rendering of the subjects was such as to place the collection on a higher level than that usually reached in exhibitions of this character.



PAINTED PANEL FOR SCREEN BY HILDA WARLOW



STENCIL NURSERY FRIEZE

BY JESSIE BESWICK

LIVERPOOL.—The recent comprehensive exhibition of students' work in the City School of Art, at the Walker Art Gallery, brought out very noticeably the steady maintenance in the good quality of painting and drawing from the life, and the advance made in modelling. Examples of good anatomical study of the male figure in action, by Thomas Shaw and George Capstick, and *The Miner*, by Robert Blackburn, displayed very even merit. A life-size study entitled *Bacchus*, by Robert Shearer, intended

## Studio-Talk

as portion of a design for a fountain, was very gracefully posed. Frances Craine's model for pedestal and bowl of fountain in marble, surmounted by a bronze nude figure, was a cleverly thought out design. Her simply-draped and well-posed *Flower Seller* appeared even more commendable as a composition. Margery Doggett has decidedly improved upon her previous essays in composition, and in her study of *Eve* she showed fine feeling. Evidence of careful training was shown by Florence Gill in a fine little group, *St. Francis and the Birds*, partly executed in alabaster, and two other works. An excellent study of a female head, by E. Spicer, a gracefully-draped *Ceres* by H. Bathgate, a recumbent figure, *Elaine*, by S. M. Johnson, a nude study by T. Rogers, and draped head by H. Quale, all deserve notice.



LITHOGRAPH PANEL : ONE OF A SERIES ILLUSTRATING HISTORIC FASHIONS BY FLORENCE K. LAVEROCK

There was a less important display of needlework design on this occasion than in previous years. An embroidered mantel-border and a panel for screen, both by Helen Bishop, represented the best examples.

A good quality of bold design and colour appeared in the two lithographs by E. R. Smart, entitled *The Windmill* (three colours) and *From the Spanish Main* (five colours). This quality was noticeable, too, in the stencil illustration *A Village Fair*, by Margaret Lloyd, and the *Nursery Frieze*, by Jessie Beswick, reproduced opposite. Two book plates of heraldic design, by E. G. Hallam and Kitty Pengelly, were

good examples of penwork, and an effective design for "University Students' Song Book" cover, by William Ellis, together with two book-cover designs by Helen Bishop, attracted attention. A well-designed theatre poster, introducing *Lady Macbeth* and the three witches, was by Jessica Walker. *Cinderella*, a humorously-treated poster, and a confectioner's window card were decidedly graceful and ingenious compositions by Edith Walters. In a similar show-card subject, Dulce Dickinson displayed effective drawing and quite attractive colour. Very interesting were a series of panels illustrating *Historic Fashion*, lithographed by Florence Laverock. Successful also in its colour scheme was the painted panel for screen by Hilda Warlow.



IRON GRILLE BY THE WROUGHT IRON CLASS, LIVERPOOL CITY SCHOOL OF ART

The work exhibited by the Wrought Iron Class was mainly of quite mediocre design, upon which much good craftsmanship was wasted; and nothing remarkable appeared in the jewellery produced by



"MAXIMINO DE SEGOVIA"

BY MISS M. CAMERON

the Enamelling Class: a copper and enamel pendant by Susan Firth being perhaps one of the best of the examples exhibited.

H. B. B.

proposed as an associate of that body; but hitherto ladies have only been selected as honorary members. Her pictures have also been hung at the

EDINBURGH.—Miss M. Cameron is not the first Scottish artist who has come under the influence of Spain, and received inspiration from the picturesqueness of the everyday life and the beautiful scenery of that country. It will be seen from the illustrations given here that she has studied very carefully the characteristics of the Spaniards, their habits and their costumes; while her versatility is exemplified in the decorative landscape *Segovia, Castille*, which is now being exhibited at the Royal Academy. It is a well-composed picture, in which the colour scheme is simple and the distance well suggested. The two figure subjects are admirable studies of character and expression, showing shrewdness of observation and vigorous execution. Miss Cameron is a regular exhibitor at the Royal Scottish Academy, and has twice been



"SEGOVIA, CASTILLE"

(Royal Academy, 1907)

BY MISS M. CAMERON



"THE CARD PLAYERS, CASTILLE"

(*Salon des Artistes Français, 1907*)

BY MISS M. CAMERON

Glasgow Institute, the Paris Salon and the Carnegie Institute, Pittsburg.

**G** LASGOW.—Marine designers have not come within the sphere of influence of the modern movement, and, in special cases, where an outside architect has been called in to advise his advice has been sought because of a reputation established along classical lines; in this way the claims of modern art have gone unheeded. The difficulties presented in marine glasswork have hitherto put æsthetic considerations out of court: vibration, curvature, peculiarities of lighting, and other features have monopolised attention. But the modern artist recognises no difficulty; with an innate adaptability he can enter a new field and command immediate success.

A visit to the studio and craft rooms of Oscar Paterson, interesting at all times, is doubly so at present because of the activity over a novel process of stained glass work chiefly designed for ship decoration. Many examples of the

noted glassworker's new development may be seen. The process might be termed a variation in Venetian glass technique, by cloud-like etching, brilliant facet-cutting, engraving and enamelling.

Another new method of his—"Ivory," to give it a designation—is a fluorescent glass, like the "uranium" variety, flashed on one or both sides, the effect, ornamental or pictorial, being produced by first etching with hydrofluoric acid, then decorating by engraving and cutting, finishing, in fact, with the lapidary's art.

Amongst the striking examples in the new process are the design for a curved ceiling of a ship's smoking room—glass, mostly white, cut and engraved for refraction; sides, inlay of opalescent glass; centre filling, glass of peculiar texture; all leadlines of cored steel to lessen vibration; design for a roof-light cupola in French style with Watteau panels, and enamelled ovals; one for a saloon cupola in similar style; and another for a lounge or music-room, all white to avoid the diminution of light—chiefly leadwork here, little

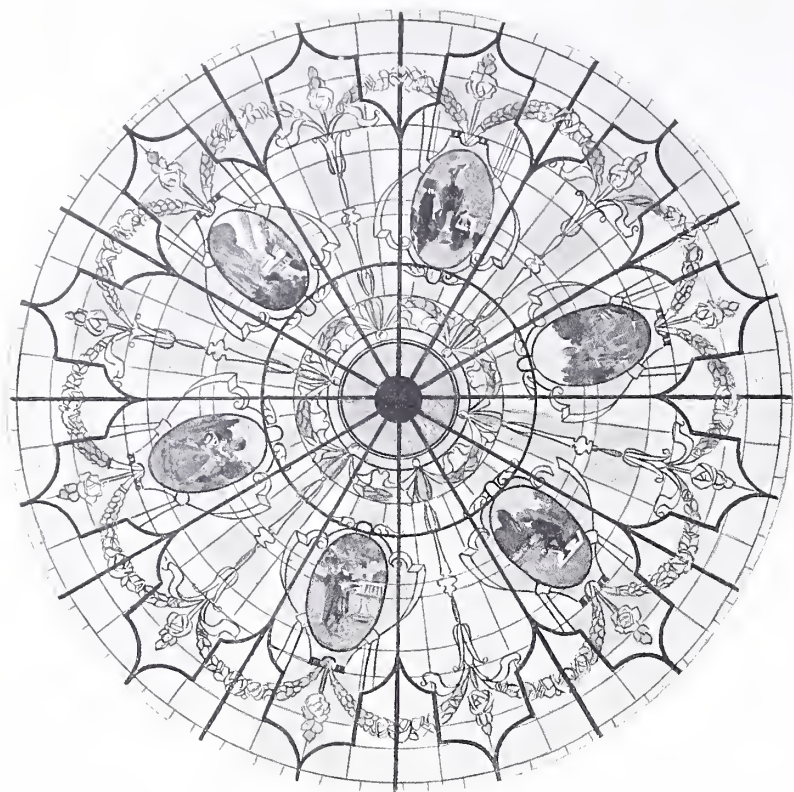

LEADED GLASS PANEL FOR DOME OF LADIES' ROOM

BY OSCAR PATERSON

brush-work of any kind ; made up of Venetian glass, modelled glass, and Norman slabs. In this parts are cut and engraved, not by way of indicating a pattern, but to give that quality of texture so interesting to a surface.

The latest addition to the list of Glasgow restaurants, "The Arcadian Gallery," at 132 St. Vincent Street, is likely to be popular because of the novel idea of introducing a continuous exhibition of pictures by contemporary artists along with a measure of food reform on vegetarian lines. The premises are bright and appropriately fitted for the purpose, and if there be anything in the theory of the French scientist that nervous diseases may be entirely cured by the use of certain colours, "The Arcadian Gallery" may work a marked change in the temperament of its *habitués*.

The white wood-work and brown paper walls have a soothing effect, and form an excellent background for the pictures. A feature in the permanent decoration of the saloon is the effective pastel drawing in the panel over the mantel, by Henry T. Wise, the artist who planned the structural alterations and the interior scheme also.

J. T.

**D**UBLIN.—The troubled times which have fallen upon the Royal Hibernian Academy would seem to have had no injurious effect upon its annual exhibition. This year the Academy opened a month earlier than usual, to enable exhibitors to transfer their

works, if necessary, to the exhibition of International Art now being held in Dublin ; and if unequal in merit the collection included some works of quite remarkable interest and worth. The portraits were the chief attraction, and incomparably the finest of these was Mr. Sargent's presentation portrait of *Mr. Hugh Lane*—a magnificent study, considered simply as a work of art, faultless in



SALOON AT THE ARCADIAN GALLERY, GLASGOW

DESIGNED BY HENRY T. WISE

## Studio-Talk

drawing, brilliant in execution, the tones perfectly balanced, the values subtly indicated, and, besides this, a remarkably truthful likeness.

Some of the other portraits exhibited were also quite admirable. Notable amongst these were Miss Purser's portrait of *Dr. Atkinson*; Sir George Reid's portrait of the late Chief Secretary, *Mr. James Bryce*; Mr. Charles Shannon's portrait of *Robert Gregory*; Mr. William Orpen's *Mrs. Fry*; Mr. Lavery's *Lady in Pink*; and Mr. Dermond O'Brien's portrait of his father.

Among the Irish landscape painters represented, Mr. Hone took a leading place. His work has the unconcernedness of nature; his temperament has become so fused with his subject that his work seems free from all artificial conventions. Mr. Hone reveals not his own temperament alone, but an elusive, haunting spirit that seems to become almost visible as we gaze—the very soul of the country which he has loved to paint. Amongst the other exhibitors of landscape may be mentioned Mr. Vincent Duffy, Mr. Dermond O'Brien, Mr. H. Scully, and Mr. Henry Allen.

Public opinion in Ireland is overwhelmingly hostile to the proposal that the Academy school be abolished and its place taken by a Government school under the control of the Department of Agriculture. It is felt that, however many the shortcomings of the Academy may have been in the past, nothing would be gained by the transfer of its school to a Department which already has more irons in the fire than it can conveniently heat. There is a strong feeling against setting up a new edition of South Kensington in Ireland, and a strong

desire that the Academy, which has recently shown evidences of a progressive spirit, should receive practical encouragement at the hands of the Government instead of extinction. The one reform that is really needed is the strengthening of its teaching staff.  
E. D.

**W**EIMAR.—The modern art movement has developed first of all in that department of architecture to which, here in Germany, the term "profane" is applied—that is to say, in cottages, stores, warehouses, factories, railway stations, interiors of private houses, libraries, and generally in that sphere of art covered by the term "Innenkunst"; and its most conspicuous trait is a tendency towards the expression of pure logic and common sense, by aiming at simplicity of construction. This evolution, which gives rise to problems

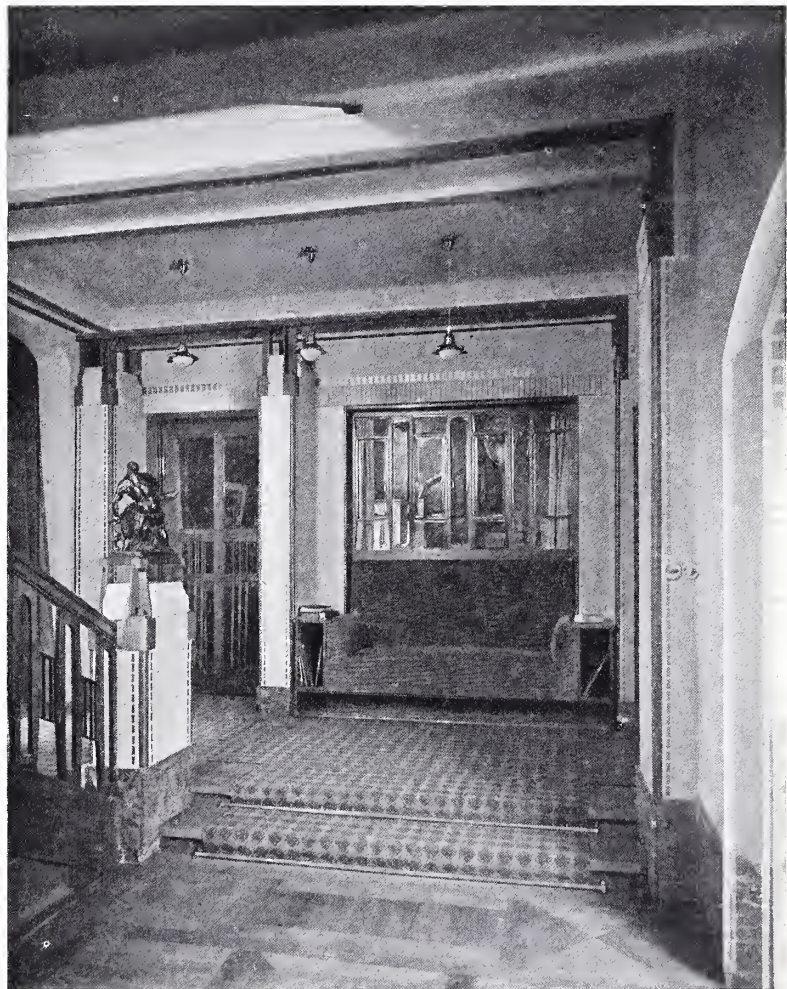

LOBBY AT MR. GUTBIER'S GALLERY, DRESDEN      DESIGNED BY H. VAN DE VELDE

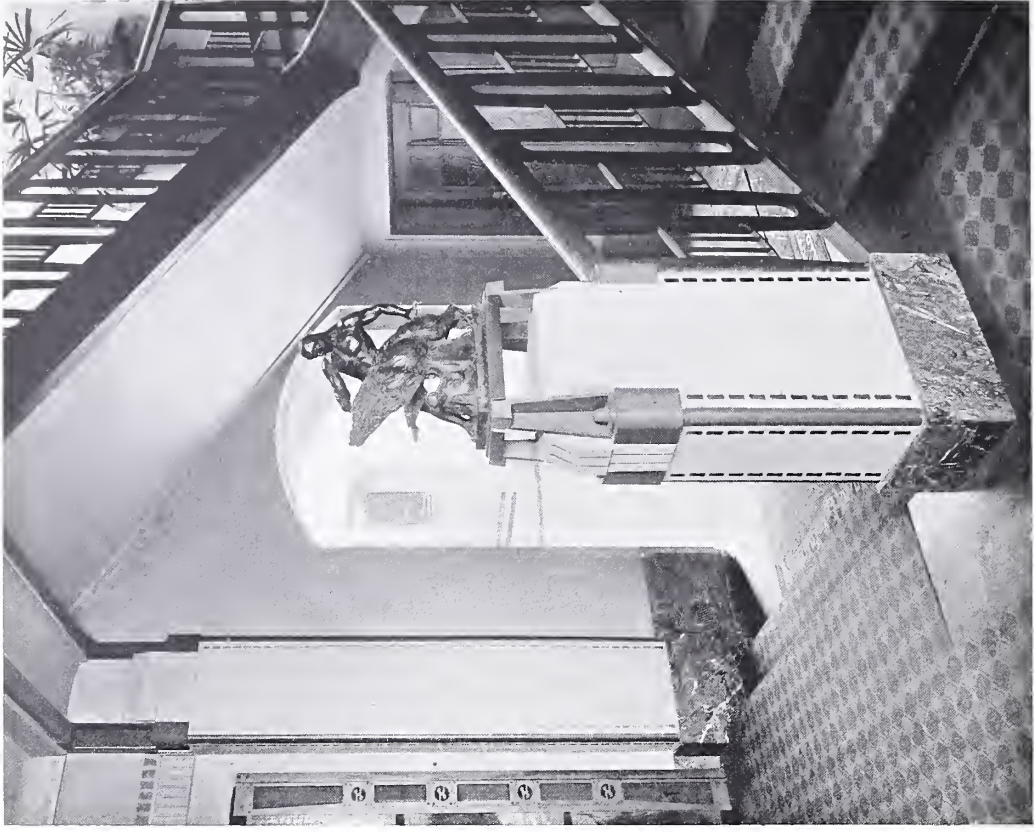

LOBBY AND STAIRCASE AT MR. GUTRIER'S GALLERY, DRESDEN  
DESIGNED BY H. VAN DE VELDE

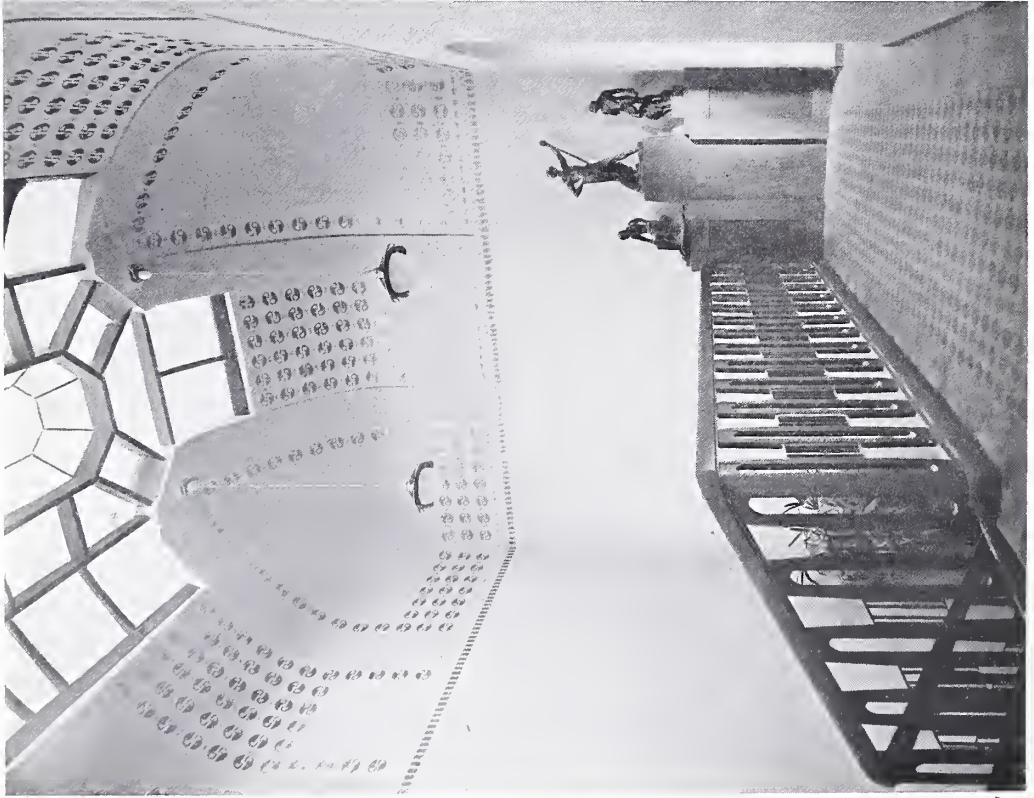

LANDING AT MR. GUTRIER'S GALLERY, DRESDEN  
DESIGNED BY H. VAN DE VELDE



## Studio-Talk

of an ethical as well as an æsthetic nature, encounters difficulties where, as often happens, a building or suite of rooms has to be re-adapted to purposes for which the original style and character of the design are entirely unsuited.

Prof. van de Velde has lately met with marked success in dealing with these and other problems confronting him. His method of treatment, which at one time showed a preference for the flowing line, is now characterised by a strict adherence to the straight line and rectangular style; this is well exemplified in some of his later productions, as, for instance, the library of the Nietzsche-Archiv at Weimar, Count Kessler's drawing-room, and various other private apartments at Lübeck, Kiel, Chemnitz and elsewhere, and again in the counting-house of a bank at Mannheim.

The designs here illustrated comprise a part of the premises of Mr. Gutbier, the art dealer, formerly known as the Arnold'sche Hofkunsthändler. In the staircase the iron portions, instead

of being concealed, have been intentionally left uncovered, and such use of the material naturally gives rise to new problems of form and colour. Besides iron, the materials used include stained oak, marble and plaster; the colour scheme is blue, with grey and gold for the stencil ornament on wall and ceiling. Turning next to the ante-room, the walls here are held in grey and pink; the glass cabinets containing silverware, jewellery and pottery from the Thuringian Factories at Bürgel, near Jena.

W. S.

PARIS.—Notwithstanding the preparations for the opening of the annual salons, numerous small exhibitions were held here in private galleries during the month of April. The most important among them was the one held at the Cercle Volney, where a retrospective exhibition of the works of Henner was arranged by a group of his ardent admirers. The collection enabled one to study the evolution of this highly gifted master, who, while continuing faithful to the same form of art, was unfortunately



A ROOM AT MR. GUTBIER'S GALLERY, DRESDEN

DESIGNED BY H. VAN DE VELDE

## Studio-Talk

unable with advancing years to maintain the same standard of craftsmanship. On comparing some of his works painted before 1870 and others more recent, it could be seen that the peculiar pallor and cadaverous appearance of the flesh in some of his female figures are qualities belonging to his last years, which were years of decadence. But how pure and fresh were the flesh tones in such works as *Adam et Eve devant le Corps d'Abel*, *le Pêcheur et le petit Poisson*, *le Paysan en blouse bleue*, *le Garçonnet!*

At the Petit Galleries there was an interesting exhibition of engravings and coloured etchings by M. Pierre Waidmann. In the large saloon of the same gallery the annual display of the Society of Pastellists was a brilliant affair, while the smaller rooms in the Rue Godot de Mauroi presented an attraction to connoisseurs in a collection of drawings and pastels by M. Henri Zuber. Artists of Normandy were in evidence at the Galerie des Artistes Modernes, where they showed some very picturesque scenes and landscapes solely emanating from that region and replete with local colour.

H. F.

**B**ERLIN.—The exhibits from the Emperor's majolica and terra cotta workshops at Cadinen attracted crowds to the rooms of the Hohenzollern Kunstgewerbehaus. The Emperor bought the estate, which is on the north-eastern border of Germany, in 1898, and as the clay was found suitable for terra cottas, his Majesty, as landlord of this district, thought the emigrating tendency of the East Prussian population might be checked by creating a new branch of industry. Artistic wishes were satisfied by the association with it of sculptors like Manzel, Baumbach, Begas and Felderhoff for designing models. In 1905 work rooms for majolica were opened. In this department Mr. O. Bachmann superintends, and the painter Paul Heydel in Berlin supplies choice copies from Italian patterns, and also new designs. Cadinen has already furnished architectural ceramics for public and private buildings, and if the quality and quantity of the clay layers do not disappoint experts the Royal Cadinen Factory will certainly flourish.

The Secession and the Great Berlin Art Exhibition have just thrown open their doors. We shall speak more fully of these most important of all German exhibitions later, but this much

may for the present be said, that they certainly prove that German art makes steady progress. The Secession is bearing fruit everywhere, but it is regrettable that its leaders are still propagating a too pronounced spirit of coarseness and dash which is hurtful to the modest spirit of the highest art. The Grosse Berliner Kunstausstellung is not only a success in the matter of artistic results, but also in that of interior decoration.

J. J.

**V**IENNA.—A talented young sculptor whose work I should like to bring to the notice of readers of THE STUDIO is Richard Jakitsch, a native of Graz, in Styria. As a student at the Imperial Academy here, where he studied under Professors Kundmann and Hellmer, he won many prizes, culminating in one awarded by the Government, of the value of £150, which enabled him to prosecute his studies in Rome. It was fortunate for him that great as was the impres-



“HUMANITY”

BY R. JAKITSCH

## Studio-Talk

feeling. Of the examples of his work here reproduced the head is from a tombstone in a cemetery in Upper Austria and is chiselled in Dalmatian marble. The entire figure is larger than life size, and reclines at the foot of the headstone. The group of figures called *Humanity* is in the vestibule of the Institute for the Blind in Vienna, and the meaning of the title is obvious. The third subject is an Italian *motif*—the two fisher boys are seated on the shore



PART OF FIGURE FOR A TOMBSTONE BY R. JAKITSCH

sion made upon his mind by the masterpieces which there abound, he had sufficient independence of spirit to preserve him from becoming a mere copyist—a fate which it is to be feared only too often overtakes many of the young men whose student days are attended by success. Jakitsch exhibited at the International Exhibition at Paris in 1900, and was awarded honourable mention for his work. Among numerous commissions which have been entrusted to him during the brief interval since his student days in Rome, may be mentioned the memorial to the celebrated African explorer, Emil Holub, in the Central Cemetery, Vienna, a work marked by much originality of conception. A more important work is the monument over the grave of Countess Chodulinsky, symbolising *The Resurrection*. It is a work marked by deep religious



"ECCO LÁ!"

BY R. JAKITSCH

intently gazing into the dim distance, and have caught sight of the vessel which may be bringing back a parent. "There she is!" they exclaim. These examples are, I think, sufficient to show that Richard Jakitsch possesses genuine artistic feeling and psychological insight.

I regret that owing to an unavoidable mistake in my article on the Arts and Crafts Schools, two or three months ago, a plaster model was accredited to Nora von Exner, a student in Prof. Metzner's class, instead of to Emilie Simandl, who belongs to the same class. This talented young sculptress is a native of Znaim, in Moravia, and studied three years at the "Fachschule" for pottery



DOG

BY EMILIE SIMANDL

## Studio-Talk

there. On finishing the course there she was awarded a special stipend, which enabled her to come to Vienna and study porcelain manufacture and design under Prof. Linke. She now, however, devotes her whole attention to sculpture, and shows marked talent in this direction. A. S. L.

**W**ARSZAWA.—It by no means frequently happens that the appearance of works by a hitherto unknown artist on the walls of the permanent exhibition of the Warsaw Society of Fine Art is regarded as an artistic event. And still more rarely, perhaps, does it happen that politico-social incidents, which are fresh in the memory of everyone living and have not yet been subjected to the sobering influence of time, come to be embodied in works of art. An instance of this unusual conjunction of *actualité* and genuine artistic perception is furnished by the paintings, here reproduced, of Maurice Minkowski, a quite young Polish painter of Jewish origin.

The *motifs* for these paintings were afforded by the barbarities perpetrated in the course of "pogroms" at Bialystok and Siedlce, atrocities which have called forth a cry of horror from the whole civilised world. As an artist, however, endowed with the instincts and feelings of an artist, Minkowski has naturally avoided the lurid presentation of a newspaper reporter, and has refrained from upsetting our nerves with pictures dripping with blood. The sufferings of his co-religionists have, of course, made a deep impression on his mind, but his strong emotion has found vent in broadly-treated *genre* paintings and drawings, in which anything savouring of theatrical

sensationalism has been studiously suppressed. Neither in the picture called *Homeless*, nor in that in which the young artist presents to our view a group of unhappy people who have just emerged from the horrors of a "pogrom," is there any attempt to import dramatic gesture or to show signs of poignant anguish in the features of the creatures depicted. Has he not, on the contrary, by investing his characters with a stolid calm, and concentrated resignation, given a far more striking and suggestive effect than any tragic, passionate presentation could produce? The artist's intense psychological vision enables us to discern in the faces we see in his pictures a consciousness of wrongs endured and hopelessness for the future. It is, indeed, a matter of surprise to find so youthful an artist gifted with the power of expressing human pathos with such sincere feeling and such artistic restraint.



"HOMELESS"

BY MAURICE MINKOWSKI



“VICTIMS OF A ‘POGROM’”

BY MAURICE MINKOWSKI

Minkowski's unusual talent as a draughtsman, and the individuality of his treatment of the human figure are apparent at the first glance, even in a black-and-white reproduction. His pictures, however, reveal in addition a strong sense of the beauty of paint, and the harmony of the various patches of colour in them points to a subtle sense of colour. The brown check shawl, the flesh tint of the exposed bosom, and the blue dress of the girl in the picture called *Homeless*, constitute a very pleasing colour-harmony, which is accentuated by the subdued, melancholy tone of the painting as a whole. In the other picture the young girl lying down to the right, with half-open eyes, pale complexion, light reddish hair, and blue blouse, is in itself a very fine bit of painting, while in the harmonious rendering of the clothing and red stockings of the wounded little girl in the middle and the blue china mugs the quality of the painting may be called refined. On the whole his male types are less successful, both from a psychological point of view and as regards their colour treatment.

Maurice Minkowski was born in Warsaw, and

has only recently completed his studies at the Academy of Fine Arts in Cracow, where he distinguished himself. The first works with which he has made his *début* (besides the two reproduced there is a third which should be mentioned, called *The Invalid Sister*, an admirably painted figure of a girl in blue) prove that he has reached an almost disquieting stage of technical and artistic maturity. Let us hope his future development may be in the same upward direction as hitherto. P. E.

**M**ANNHEIM.—The Jubilee Exhibition of Art and Horticulture, now being held here under the patronage of the Grand-Duke of Baden, is evoking great interest throughout Germany. It occupies an area of about ninety acres, the greater part of which is laid out in a novel and original manner, in accordance with the independent ideas of artists and garden architects (a recognised profession in Germany). The schemes comprise a natural amphitheatre formed by tiers of flowers, an old Roman garden, a garden of old-fashioned flowers, a model villa garden, a Japanese garden, and numerous other interesting features.

## Studio-Talk

STOCKHOLM. — It is with unvarying satisfaction and interest that one always returns to the work of that admirable society, "Handarbetets Vänner," Stockholm, in every respect a model institution. New ideas and new schemes are constantly being brought forward by the many gifted artists who are connected with the Society, and an appreciative and understanding *clientèle* makes it possible to realise them. Of late, linen has in many cases replaced wool in their weavings, in which new departure, if one may call it so, Mlle. Carin Wästberg, the present artistic manageress, takes a warm interest. Linen under many circumstances assumes an almost silky gloss, and the colours of "Handarbetets Vänner," generally vegetable colours, are famed for being singularly chaste and refined. In the way of ornamentation during the last year or two some highly original and decorative designs have been introduced, and the matching and

blending of colours is often extremely happy and quaint.

Amongst the accompanying illustrations the first place, by rights, is due to a very large and handsome gobein, a present to the Crown Princess of Sweden on the recent occasion of her silver wedding, from a number of Swedish ladies. It is designed by Mlle. Lotten Rönqvist, is 11½ ft. by 10 ft., and was woven by nine ladies in the short time of four months. The tapestry, *en verdure*, represents a view from Skeppsholmen, Stockholm, the royal palace appearing in the distance. Carnations, the favourite flower of the Princess, ornament the foreground. In the broad border oak and lime alternate, and within these are to be found the coats-of-arms of Sweden and Baden, of the City of Stockholm, and of the twenty-four Swedish provinces; they are worked in gold and silver, and silk is also used in several places.

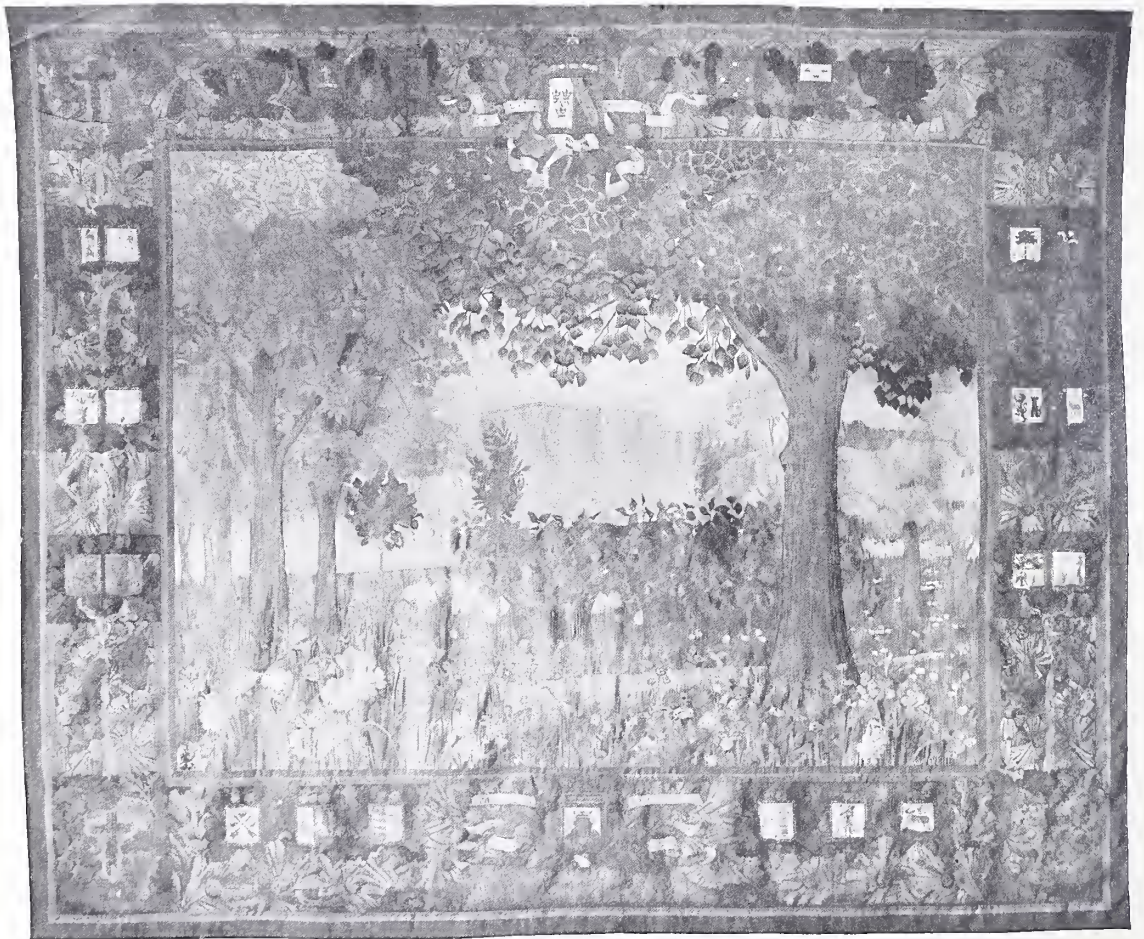

GOBELIN PRESENTED TO THE CROWN PRINCESS OF SWEDEN

DESIGNED BY Mlle. LOTTEN RÖNQVIST AND  
EXECUTED BY HANDARBETETS VÄNNER, STOCKHOLM



“FUGA” : LINEN HANGING  
DESIGNED BY Mlle. CARIN WÄSTBERG  
EXECUTED BY HANDARBETETS VÄNNER,  
STOCKHOLM

A hanging designed by M. Gunnar Hallström represents the old Northern myth of the Yggdrasil. The warp is here vertical, contrary to what is the case with all old and most modern tapestries ; the mode of weaving appears from the fringe-like warp ends at the bottom. The dyeing has been done by Mlle. Märta Leijonhufvud, but the colours in this case are not vegetable, inasmuch as these would not lend themselves to the hues and tones insisted upon by the artist. On this page is also shown a *hauteline* hanging in linen, designed by Mlle. Carin Wästberg. In the summer of 1903 the sounds and the contours of the young forest at Hardinge inspired Mlle. Wästberg with this subtle and charming design, and the hanging is known as the “Hardingë Fuga.”

Ecclesiastical embroidery forms an important department of the “Handarbetets Vänner,” and affords excellent scope for work of great beauty.

As an adequate example, we reproduce an antependium, designed by the well-known architect, M. Ferdinand Boberg, whose rare gift of ornamentation may be recognised more especially in the central design. The material is red velvet with silk and gold embroidery. Another antependium, designed by Mlle. Agnes S. Skogman, is of violet silk, worked with silk, silver and gold. The thistle has formed the ornamental *motif*. A portion of an antependium designed by M. Falkenberg, architect, is also illustrated ; it is of



“YGGDRASIL” HANGING  
DESIGNED BY GUNNAR HALLSTRÖM  
EXECUTED BY HANDARBETETS  
VÄNNER, STOCKHOLM



ANTEPENDIUM

DESIGNED BY AGNES SKOGMAN  
EXECUTED BY HANDARBETETS VÄNNER, STOCKHOLM

red cloth with violet  
brocade application  
and silk embroidery.

Cushions, large and  
small, simple and  
elaborate, have  
emanated in large  
numbers from "Hand-  
arbetets Vänner."  
The first of the two  
on page 81 is a silk  
cushion, embroidered  
with silk; its old-time  
pattern has been  
adapted by Mlle.  
Maria Adelberg. The  
other is a linen  
cushion. G. B.

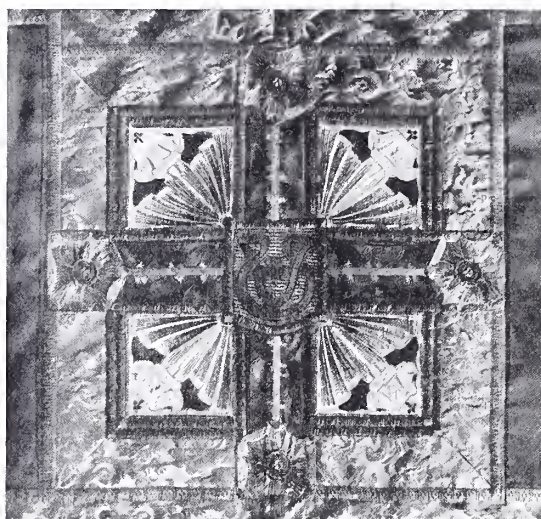

DETAIL OF ANTEPENDIUM

DESIGNED BY FALKENBERG, ARCHITECT  
EXECUTED BY HANDARBETETS VÄNNER,  
STOCKHOLM

MELBOURNE.  
—The  
Public  
Library  
Trustees have de-  
cided that in future  
the Felton Bequest  
Fund is to be used  
for purchasing repre-  
sentative works by  
artists of pre-emin-  
ence in the art-world,  
rather than in the  
indiscriminate col-  
lecting of works of  
a merely momentary  
popularity — a de-  
cision that is to be  
commended.

J. S.

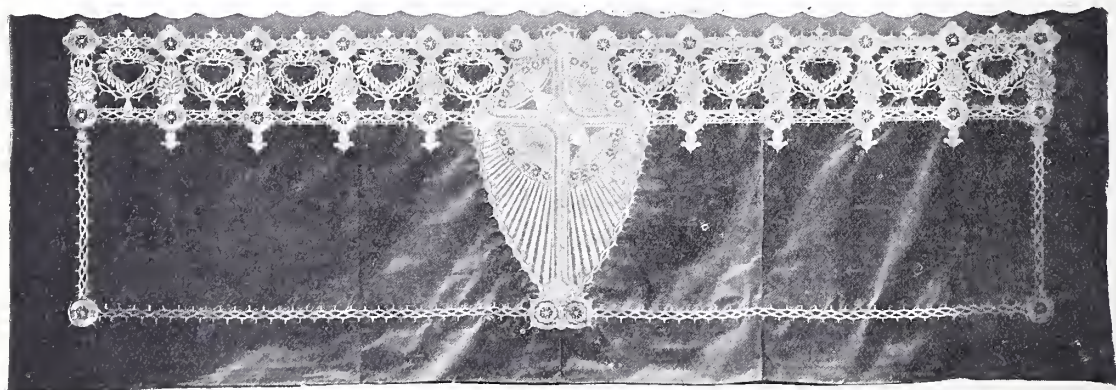

ANTEPENDIUM

DESIGNED BY FERDINAND BOBERG  
EXECUTED BY HANDARBETETS VÄNNER, STOCKHOLM





EMBROIDERED CUSHIONS  
 DESIGNED BY MARIA ADELBERG AND  
 MARIA SJÖSTRÖM. EXECUTED BY  
 HANDARBETETS VÄNNER, STOCKHOLM  
 (See *Stockholm Studio-Talk*)

in the South, organized in 1906 among the principal Southern cities a co-operative movement which enables these cities to obtain at minimum cost an exhibition representative of the best in American art. Nashville, Tennessee; Atlanta, Georgia; New Orleans, Louisiana; Tampa, St. Augustine, and Palm Beach, Florida; Charleston, South Carolina; and Baltimore, Maryland, are among the cities which have held or contracted for the exhibition.

Apart from the interest which attached to the exhibition as the achievement of the first concerted effort made by the new South toward art development, the merit of the pictures was of the highest. Taken as a representative collection of American paintings, it would indicate that the promise of American art lies in the landscape painter. Many admirable examples of landscape painting were to be seen, such as the *Autumn Scene, Peekskill*, by George Inness, Sr. (deceased); a *Landscape*, by John Twachtman (deceased); George Bogert's *Autumn Sunset*; *November Pastures*, a notable picture by H. W. Ranger; *The Valley*, by Gifford Beal, beautifully painted and possessing fine atmospheric qualities; Charles Warren Eaton's

**A**TTLANTA, GEORGIA.—The season of 1906-1907 marked a renaissance of art interests in the Southern States of America. As was emphasized by Mr. James B. Townsend, of New York, in his address at the opening of the art exhibition recently held here, art in the United States had its beginning in the South. Early settlers of gentle birth brought to the South not only art treasures, but an inherited love and knowledge of art, and families of wealthy Southern planters even crossed the sea to have portraits painted by Reynolds, Romney, or Gainsborough, perhaps, or sat for portraits to Gilbert, Stuart, Copley, the Peales, Trumbull, Jarvis, and later to Sully and other American masters. The Civil War closed to this part of America for a time the avenues of culture, and it was not unnatural that art should be the last to revive. Mr. Townsend was in 1901-2 director of art at the Charleston Exposition, and becoming convinced of the development



"THE SECRETARY" BY WALTER MCEWEN  
 (Photo, Jessie T. Beals, New York)



"THE TURKEY HUNTER"

(Photo. J. A. Lyon, New Orleans)

BY E. IRVING COUSE

*Sentinel Pines*, satisfying in the simplicity of its composition and in the harmony of its colour relations; E. Irving Couse's *Turkey Hunter*; *Night—The Pool*, by Harry Haviland Osgood, a picture in which the mysterious charm of the "huge and thoughtful night" is wonderfully embodied; Lewis Cohen's *Autumn*, vigorously but delicately painted and exquisite in colouring; *The Sycamore*, by W. L. Lathrop; Ben Foster's *After the Rain*; A. T. Van Laer's characteristic *Evening*: an exquisite sunset scene by R. C. Minor; *A Coming Storm* by A. H. Wyant (deceased); Isaac Josephi's daintily painted *Landscape*; *The Lilliputian Boatlake*, a graceful piece of work by William Chase; Arthur Parton's *Summer Showers*; R. A. Blakelock's *Cloudy Morn, Maine*; Arthur Dawson's *Wood Interior*; *Woods in Spring*, by Leonard Ochtman; Wm. Howe's *On the Road to Market*; and W. Merritt Post's *Lowland Farm*. Leon Dabo's *Hudson River* stood

Ewen's *The Secretary*, Luis Mora's *Spanish Lady and Maid*, Henry Mosler's *Dutch Woman*, Charles

alone in its mystic beauty and peculiar atmospheric qualities. This painter's unique work has been termed "the impressionism of Whistler projected into infinite possibilities."

A great picture of the exhibition was Robert Henri's *Spanish Dancer*, a wonderful piece of work, virile and compelling, and done with bold, impassioned strokes of the brush. The boldness of the pose, the devilry in the black eyes, the wonderfully painted arm, throat and chest, made an *ensemble* pulsating with life and colour. Other figure subjects worthy of mention were Douglas Volk's *Boy with Arrow*, Walter Mc-



"THE SYCAMORE" (Photo. J. A. Lyon, New Orleans) BY W. L. LATHROP

## Reviews and Notices

Naegle's *Herculia*. Among excellent marine pieces Marcius Simons' *Silver Hour* was especially noteworthy. Mention of many other meritorious works must necessarily be omitted because of lack of space, there being over one hundred artists represented in the collection. S. ARMSTRONG.

### REVIEWS AND NOTICES.

*On Art and Artists.* By MAX NORDAU. (London: T. Fisher Unwin). 7s. 6d. net.—As a contribution to the literature of æsthetics this book is a disappointment coming from so clear a thinker, but a scientist gifted with artistic sympathy and with an unusual amount of courage. Dr. Nordau writes interestingly; he is not at pains to square his opinions with accepted ones of the day, and his contempt for insincere and evasive criticism is admirable. In our opinion one of the most illuminating chapters in the book is that on "Whistler's Psychology," which attempts a scientific explanation of the unprecedented nature of Whistler's visual gifts. In the first pages of this criticism the scientific method is used at its best; further on, it loses in authoritativeness from a less scrupulous use of scientific terms; and the last two pages may we think be dismissed as showing us nothing but the propensity of a specialist for inventing the presence of a favourite disease. In his effort to prescribe the boundary within which the art of sculpture should find its meaning, a too logical method of thought has, we think, betrayed the writer; for, after all, it is outside the strictly logical that art enters upon the field of its happiest expression. With Rodin, sculpture does but follow the other arts, as in turn they have signified their recognition that with man as the subject for representation some symbol must pass in acknowledgment of the atmosphere always surrounding him, which would seem to claim him with invisible hands as part of the universal scheme. Like the painter Carrière, it would seem Rodin understands how "to make mystery the gate of an unreserved revelation." Nowhere does Dr. Nordau speak with greater feeling than in his essay on Eugène Carrière, for here he writes from the experience brought him by his own sympathy; Despite its faults as a purely critical work, the book throughout has one quality which ranks it with the most valuable art criticism, and that is its author's skill in stripping from his subjects those pretensions to literary motive, which in so many cases obscure the minds of thinking people as to the real issues in discussion of the plastic arts and

the nature of the motives which alone are responsible for artistic success.

*The Colour of London: Historical, Personal, and Local.* By W. J. LOFTIE, F.S.A. Illustrated by the Japanese artist, YOSHIO MARKINO. With an Introduction by M. H. SPIELMANN, F.S.A., and an Essay by the Artist. (London: Chatto & Windus), 20s. net.—London has been a fruitful source of inspiration to so many writers, that one would have thought it impossible to treat the subject from a fresh standpoint. Mr. Loftie, however, has succeeded in producing a book on London treated in an original and interesting manner, and is to be congratulated accordingly. He has interpreted the term "colour" in its broadest sense and has drawn extensively upon the wonderful traditions of the great metropolis; indeed, the most interesting chapter in the volume is devoted to the history and description of the Tower. To many, however, the most attractive feature of the book will be the series of delightful illustrations by Mr. Yoshio Markino, reproduced in colour and monotone, the originals of which were recently exhibited at the Clifford Gallery in the Haymarket. Possessing a delicate sense of colour and tone harmony, the artist has been inspired by some typical scenes of London street life to produce a number of drawings which are extremely fascinating, and bear the stamp of exceptional ability. Mr. Spielmann, in his introduction to the volume, says "it is the night scenes that arouse Mr. Markino's greatest enthusiasm, and many of the studies made when the streets are ablaze with artificial light are pregnant with subtle beauty." The best of these evening subjects, *Lights in Piccadilly Circus*, forms the frontispiece to the book, while another, *The Alhambra, Leicester Square*, though not so rich in tone, is full of charm. Of the sepia drawings, *Feeding the Gulls, Blackfriars Bridge*, is the most successful, excellent both as regards its fine atmospheric quality and clever draughtsmanship.

*Alfred Stevens et son Œuvre.* By CAMILLE LEMONNIER. (Brussels: G. Van Oest et Cie.) Three editions, 300, 200, and 80 francs.—Aptly called the painter of Parisian grace, for he stands almost alone amongst modern interpreters of French fashionable women, Alfred Stevens, whose life-work was reviewed in *THE STUDIO* soon after his death, has found a very sympathetic biographer in his fellow-countryman, Camille Lemonnier. Few will, we think, be disposed to endorse the latter's comparison between the popular portrait-painter and Millet le Rustique, for the natures and aims of the two artists were essentially different, but with this

## Reviews and Notices

exception the acumen shown by the Flemish writer is never at fault. His essay is a masterpiece alike of literature and of criticism, and it was a happy thought to bind up with it Stevens' own "Impressions sur la Peinture," which appeared in 1866. The forty-two plates accompanying the text include, with reproductions of a number of acknowledged masterpieces, two or three interesting studies; great care appears to have been bestowed on the get-up of the volume generally, and it may be commended as a worthy memorial of a remarkable personality who is not likely soon to be forgotten.

*History of Scottish Seals.* By WALTER DE GRAY-BIRCH, LL.D., F.S.A. Vol. II. (Stirling: Eneas Mackay.) 12s. 6d. net.—As full of scholarly research as its predecessor, this, the second volume of a very important work on the seals used in Scotland from the eleventh to the seventeenth century, treats of ecclesiastical and monastic examples only, giving a large number of excellent reproductions of typical examples showing the designs on both sides. The learned author, who was for many years secretary and treasurer of the British Archæological Association, and worked from 1865 to 1902 on the classification of the charters, seals, and MSS. in the British Museum, is a true enthusiast on the subject of heraldic devices, and has in many cases thrown fresh light on their original meaning. Unfortunately, actual specimens of the elaborate monastic seals, with their complex symbolism, are extremely rare, for they were nearly all destroyed at the dissolution of the religious houses, but impressions of many of them having been preserved, the continuity of the chronological record of Dr. Birch has been maintained. Specially interesting are the seals, dating from 1200, of the great Abbey of Dunfermline; that of the Chapter of Jedburgh, with the Coronation of the Virgin on one side and the Salutation on the other; and that of the Collegiate Church of St. Bridget at Abernethy, bearing on the reverse the figure of the patroness, attended by her cow, and the legend, *In domo Dei ambulavimus cum concensu*; but every page of the book is full of fascination, the writer combining with his antiquarian lore an eloquent style and true æsthetic feeling.

*The Cities of Spain.* By EDWARD HUTTON. With twenty-four illustrations in colour. By A. WALLACE RIMINGTON, A.R.S.A., R.B.A. (London: Methuen.) 7s. 6d. net.—Unlike many of the colour books that have recently been published, in which the letterpress is merely supplementary to the illustrations, this new work from the pen of the accomplished author of "The Cities of Umbria" and

"Italy and the Italians" is a piece of true literature, in which the very spirit of the scenes described has been caught and reproduced. Mr. Hutton knows and loves Spain well; he is in sympathy with her rugged, and often forbidding scenery, and her grand but strangely unsatisfying architecture, and calls up picture after picture that enchain the attention as completely as do the excellent water-colour drawings of his collaborator, amongst which the best are the *Ambulatory, Burgos Cathedral, the Court of Oranges, Cordova, and Outside the City Walls, Seville*. With the proud and reserved but, to those who understand them, responsive people of the Peninsula he is also thoroughly in touch. Even the actors and spectators in the bull-fights he loathes are fairly judged by this just critic, and he charges the Englishmen who hunt the stag with hypocrisy for condemning them, pointing out that in both cases "it is death they are set on," and adding the pregnant remark, "No man adventures his life against the life of the stag, nor is the skill of the hunter set against the strength and fury of the deer, as is that of the toreador against the bull."

*The Life of William Blake.* By ALEXANDER GILCHRIST. With an Introduction by W. GRAHAM ROBERTSON. (London: John Lane.) 10s. 6d. net.—Few artists have been subjected to greater extremes of criticism than William Blake, who to some appears as a heaven-inspired genius whose every utterance in literature or art must be received with reverence, whilst to others he is a mad enthusiast, smiled at and tolerated simply because of his irresponsibility. In the Preface to the new edition of the famous "Life" by Alexander Gilchrist (which except that it has been enriched by numerous reproductions of typical works by Blake, including some not hitherto published, is practically unaltered) Mr. Graham Robertson has skilfully hit off the happy medium. He admits frankly that Blake was often unequal both in his art and in his literary conceptions, deprecates the exaggerated laudation of fugitive sketches and writings that were never intended to be taken seriously, but claims that the "Inventions of the Book of Job" were alone enough to place their author amongst the immortals. He mourns over what he calls the "holocaust of Tatham, an angel of the Irvingite Church—a destroying angel, indeed—that placed a final barrier between the poet and the world," but declares that "for the lover of perfect poetry Blake's fame will live for ever in the 'Poetical Sketches,' the 'Songs of Innocence and Experience,' and the 'Book of Thel.'"

*Inventaire Général des Dessins du Musée du*

## Reviews and Notices

*Louvre et du Musée de Versailles.* Vol. I. (Paris: Librairie Centrale d'Art et d'Architecture.) Prefaced by an account from the pens of the well-known French critics, MM. Jean Guiffrey and Pierre Marcel, of the origin and growth of the fine collections of drawings now in the Louvre and Versailles Museums, this, the first volume of a most important work, deals exclusively with the French school. It consists of a very complete, alphabetically arranged catalogue *raisonné*, illustrated with reproductions of 427 drawings, and giving, in addition to descriptions of nearly 800 examples, lists of the principal engravings after them, and brief biographical notices of their artists. The only drawbacks to a publication which, when completed, will be a notable contribution to art literature are its flimsy paper cover and general want of style, the standard of excellence in printing, binding, etc., being still, in spite of the present unfortunate rage for cheapness which threatens to lower it, much higher in England than in France.

*Romantic Cities of Provence.* By MONA CAIRD. Illustrated by JOSEPH PENNELL and EDWARD M. SYNGE. (London: T. Fisher Unwin.) 15s. net.—The original home of the Troubadours and the cradle of the chivalry their lays did so much to encourage, the sun-steeped, wind-swept land of Provence, will ever exercise a peculiar spell over the imagination of those who are able to appreciate its unique charm and are in touch with its traditions; but to be able to communicate that spell to others is given to few. Amongst these few, however, must certainly be included the author of the delightful and copiously illustrated volume recording the fleeting impressions received in a recent tour. Against the lightly sketched-in background of the past, with its allusions to the heroes and heroines of history and romance, the present stands out in vivid relief. Avignon, Orange, Martigues, Aigues-Mortes, Arles, Tarascon, Carcassonne, Les Baux and many other famous towns, are made to reveal their inner *ego's*; the reader is brought face to face with the very spirit of the silent wilderness of stones known as La Cran, and with that of its even more melancholy neighbour, the deserted Camargue, whilst the idiosyncrasies of the travellers who were met by the way are humorously touched off. There is not one dull page in the book.

*Flächenschmuck in Character der Dresdener Schule.* Von OSKAR HÄEBLER. (Stuttgart: Julius Hoffmann.) Mk. 26.—This work consists of a series of twenty-four plates in phototype, containing practical designs for textile fabrics. The author has studied weaving in all its branches, and knows the exact

value of a design in relation to manufacture, a side too often neglected by designers. He is a man of some authority in Dresden, and his name is well known throughout Germany; he arranged the textile department at the recent Dresden Exhibition, and is therefore in the way of giving lessons and hints to others. There is a distinct need for a work such as this.

*Poems by William Wordsworth.* Selected with introduction by STOPFORD A. BROOKE. Illustrations by EDMUND H. NEW. (London: Methuen & Co.) 7s. 6d. net.—In this well-got-up volume literature and art are happily associated. Mr. Stopford Brooke, in his introduction, touches eloquently on those aspects of nature which made so deep an impression on the poet, and no less eloquent from another point of view are the illustrations in which Mr. New has given us in a series of admirable pen-and-ink drawings glimpses of various places intimately bound up with one or other period of the poet's life—first Cockermouth and Hawkshead, then Grasmere, and finally Rydal. As Mr. Brooke rightly says, "the spiritual mingling of nature and man cannot be represented in illustration, but it may be suggested;" we join with him, however, in expressing our conviction that the conception and emotion of this interrelation filled the imagination of the illustrator while engaged in his work.

From Messrs. Duckworth & Co. we have received a volume by Mr. W. ROBERTS on *Sir William Beechey, R.A.* (7s. 6d. net), one of those painters of the early English school who, in spite of the high order of their talent and important influence on the development of art in this country, have been overshadowed by their great contemporaries—Reynolds, Gainsborough, and Romney. Mr. Roberts's monograph is expository rather than critical, and particular interest attaches to the chapter of forty pages in which he gives a series of extracts from Beechey's account books, principally those dated from 1807 to 1826, from which it appears that his professional income in these years fluctuated considerably from year to year, the highest total being close on £2,300, and the lowest about half as much. Numerous reproductions are given of Beechey's portraits. Messrs. Duckworth also send us an extremely interesting and scholarly study by Mrs. ARTHUR STRONG, LL.D., of *Roman Sculpture from Augustus to Constantine* (10s. net). In this volume, with its hundred and thirty illustrations, convincing proof is given in support of the contention that Roman art, the characteristics of which Mrs. Strong analyses and discusses, developed on independent lines, apart from Greek influence.

THE LAY FIGURE: ON THE STUDY OF COLOUR.

“CAN colour be taught?” enquired the Art Master. “Is it possible, I mean, to train the average student to appreciate colour subtleties and to combine colour properly?”

“I should say it would be quite impossible unless that student had naturally a colour sense,” replied the Man with the Red Tie. “The colourist is born, not made, and no amount of schooling will make any difference to a man who is deficient in the natural instinct.”

“You are partly right and partly wrong,” said the Art Critic; “I agree with you that the colourist possesses a particular endowment which comes to him as a gift from nature, but this faculty can be greatly developed by the right kind of training. As for the man who has not a colour sense innately, I believe that, unless he is actually colour blind, he can learn much from a teacher who knows how to direct him.”

“But how far can the teacher carry such a student?” asked the Art Master. “Can he be made reasonably efficient?”

“If he can be taught nothing else,” said the Critic, “he can be educated into a reasonable understanding of the rules of colour, and can be saved from making any obvious mistakes. His colour efforts will never be great, but they will at least be inoffensive.”

“He will never get beyond mediocrity, anyhow,” commented the Man with the Red Tie. “But what about the born colourist? You say that his faculties can be developed by training: what can you teach him that he does not know already? I take it that he comes into the world fully equipped, and that schooling will not affect him much one way or the other.”

“That is a fallacy,” replied the Critic. “The colourist is simply a man in whom a certain set of nerves are unusually sensitive, but these nerves can by training be made still more sensitive, and can be brought more completely under the control of his intelligence. While he remains untaught he is unable to use his powers effectively, because he does not understand them. His successes will be accidental, his methods will be erratic, and the results at which he arrives will be disconnected and probably unconvincing. Subjected to discipline, however, he will become more consistent and he will find out exactly what he should do in order to convey to others the impression that exists in his mind.”

“In other words, he acquires a scientific knowledge of what he felt before by instinct only,” broke in the Art Master, “and science gives him confidence and self control.”

“That is so,” said the Critic; “it is by the formalities of scientific study that any natural faculty can be best developed, and these formalities are as necessary for the born colourist as they are for any other man who has in him the possibilities of great achievement.”

“Wait a minute!” cried the Man with the Red Tie. “I admit that what you say is reasonable enough, but can you tell me where this scientific training in colour is to be obtained?”

“There you hit upon a very real difficulty,” replied the Critic, “and I am not sure whether I can answer your question. I know no school where colour is taught in the way it should be, or where the student can expect to be guided properly in this particular science.”

“You are wrong,” protested the Art Master; “surely the rules of colour management are taught in all art schools—at all events in those that pretend to be efficient.”

“The rules, perhaps, but not the science of colour,” returned the Critic; “let us make that distinction. What you call rules are the merest outlines, the rudiments only of an abstruse study, and even these rules are more often than not laid down by men who do not understand them. The man who would teach colour must himself be a colourist exquisitely sensitive and perfectly trained; he must be able to dissect and analyse the most subtle combinations, and to explain the details of the most elusive harmonies. For of all sciences the one with which he has to deal is the least susceptible of being governed by hard and fast rules. To arrange colour by rule is to make it lifeless and without meaning, to destroy its power of exciting emotion, and to reduce it to a mechanical balancing of colour areas. What I understand by the science of colour is the accounting for the relation between the pitch and area of the colours used in a properly adjusted combination, and the explanation of the manner in which varying colour tones can be brought into agreement so that the result of their juxtaposition is absolutely harmonious. That this science is subject to laws which call for complete obedience I admit, but these laws must be taught by demonstration not by text-books. And can you tell me of any school in which teaching of this kind is available? I think not.”

THE LAY FIGURE.



From COLLIER'S WEEKLY  
Copyright 1907 by P. F. Collier & Son

**C**HARLES DANA GIBSON says: "*The fact that I have used the Strathmore board for over ten years is proof enough that I think well of it.*"

**T**HE above characteristic Gibson drawing was drawn upon Strathmore Drawing Board, as were nearly all of the well-known black-and-white line drawings of this artist. As Mr. Gibson is a master of pen-and-ink technique, his opinion of Strathmore Drawing Boards is worth considering.

The Strathmore line of artists' papers consists of drawing papers, drawing boards, patent office board, charcoal paper, detail drawing paper, water color paper and illustrating board; 21 items to suit every medium.

The name "Strathmore" and this trade mark is your guide to the best. For sale at all art stores. Samples sent to artists on request.



# Strathmore Drawing Papers and Boards

Mittineague Paper Co., Mittineague, Mass., U. S. A.



## RED RUSSIA

By JOHN FOSTER FRASER

With 48 full-page Plates from Photographs. 12mo. \$1.75 net. Postage 10 cents.

*"Authoritative, fascinating, yet realistic to the last degree."*

—LONDON STANDARD.

Some Chapters:

The Gist of the Matter	The City of Terror (Warsaw)
The Moods of Moscow	The Black Hundred
In the Caucasus	"Bloody Baku"
Black Sea Pictures	

## STARS OF THE STAGE

A Series of Illustrated Biographies. Edited by J. T. GREIN.

*Profusely Illustrated.* 12mo. \$1.00 net. Postage 6 cents.

**Ellen Terry.** By CHRISTOPHER ST. JOHN.

*A profusely illustrated Biography, containing photographs of Miss Terry in favorite roles; paintings and drawings of her by Sargent, Aubrey Beardsley, Simpson and others, and photographs of her home and farm. Also a complete list of parts played by Miss Terry.*

**H. Beerbohm Tree.** By MRS. GEORGE CRAN.

**W. S. Gilbert.** By EDITH A. BROWNE.

## VERNON LEE

**Pope Jacynth and Other Fantastic Tales.** 16mo. \$1.25 net. Postage 10 cents.

**Genius Loci.** 16mo. \$1.25 net. Postage 10 cents.

**Hortus Vitae, or The Hanging Garden: Moralizing Essays.** 12mo. \$1.50 net. Postage 10 cents.

**The Enchanted Woods:** and other Essays on the Genius of Places. 12mo. \$1.50 net. Postage 12 cents.

**The Spirit of Rome.** 12mo. \$1.50 net. Postage 10 cents.

**Hauntings.** 12mo. \$1.50 net. Postage 10 cents.

*"If we were asked to name the three authors writing in English to-day, to whom the highest rank of cleverness and brilliancy might be accorded, we would not hesitate to place among them Vernon Lee."*

—BALTIMORE SUN.

## NAPOLEON

### THE FALL OF NAPOLEON

By OSCAR BROWNING. With numerous Illustrations.

8vo. \$5.00 net. Postage 25 cents.

*"Throws new light on the most extraordinary character of history."*—N.Y. HERALD.

### NAPOLEON IN POLAND 1806-7

NEW ILLUSTRATED EDITION. By F. LORAINÉ PETRE.

A military history of Napoleon's first war with Russia, verified from unpublished official documents. Illustrations, maps and plans. 8vo. \$5.00 net. Postage 25 cents.

*This important campaign was almost unknown to English readers previous to the publication of this work.*

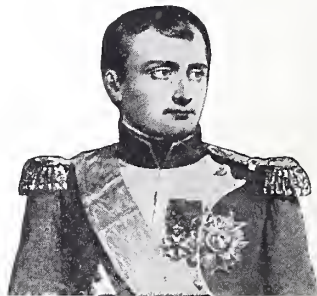

### NAPOLEON'S CONQUEST OF PRUSSIA, 1806

By F. LORAINÉ PETRE. With an Introduction by Field-Marshal Earl Roberts, K.G., etc. With numerous Maps, Battle Plans, Portraits, and many other valuable Illustrations.

8vo. \$5.00 net. Postage 25 cents.

*"A more complete and concise account of this campaign than has yet appeared in English."*—NEW YORK HERALD.

**JOHN LANE CO., 110-114 West 32d St., NEW YORK**



# THE LONESOME TRAIL

*The West and the Frontier*

By JOHN G. NEIHARDT

Illustrated. 12mo. \$1.50

Mr. Neihardt's pictures of the life of the modern Indian, the Trapper, the Half Breed—the untamed West of the day—are familiar to readers of magazines.

*"The most virile and original note since Jack London."*

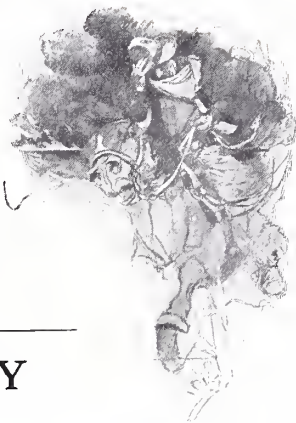

## THE WINGLESS VICTORY

*"The London Literary Success"*

By M. P. WILLCOCKS. Author of "Widdicombe." 12mo. \$1.50.

"A moving drama of passion, of frailty, of long temptation and of ultimate triumph over it."—*Pall Mall Gazette*.

"Unerring insight into the deep springs of human action."—*London Mail*.

"Miss Willcocks belongs to the school of Thomas Hardy, though her story is devoid of imitation."

—*London Telegraph*.

## FOR THE WEEK-END

A LOVE STORY

By HANDASYDE, Author of "Four Gardens." 12mo. \$1.50

### *The* DANGERVILLE

A DETECTIVE STORY

"A detective story of which Gaboriau might be proud."  
—*London Post*.



### INHERITANCE

By A. C. FOX-DAVIES

12mo. \$1.50.

"Of the Wilkie Collins order."—*N. Y. Times*.  
"Plenty of excitement."—*Detroit News-Tribune*

## AS YE HAVE SOWN

By DOLF WYLLARDE. Author of "The Story of Eden," etc. 12mo. \$1.50.

"Dolf Wyllarde sees life with clear eyes and puts down what she sees with a fearless pen. . . . More than a little of the flavor of Kipling, in the good old days of 'Plain Tales from the Hills.'"—*New York Globe*.



## WILLIAM J. LOCKE

THE BELOVÉD VAGABOND

"One of the most complete, convincing and entirely delightful characters that have made their début between book covers for a long time."—*New York Times*.

THE MORALS OF MARCUS ORDEYNE

"By far the best thing he has done."—*Dial*.

AT THE GATE OF SAMARIA

WHERE LOVE IS

A STUDY IN SHADOWS

THE DEMAGOGUE AND LADY PHAYRE

THE USURPER

DERELICTS

IDOLS

THE WHITE DOVE

12mo. \$1.50 each.

**JOHN LANE CO., 110-114 West 32d Street, NEW YORK**



# International Studio Extra Numbers

(LIMITED EDITIONS)

*These volumes are issued in strictly limited Editions, and the publishers reserve the right to advance the price of same after the date of publication*

- Art in 1897:** Being a pictorial record of the most famous exhibitions in that year. 4to, cloth. \$2.50 net. Postage, 30 cents.
- Art in 1898:** Being a pictorial record of the most famous exhibitions in that year. 4to. In paper, three parts, \$1.50 net; in cloth, one volume, \$2.50 net. Postage, 30 cents.
- Children's Books and Their Illustrators.** (Winter Number, 1897-98.) By Gleeson White. Wrappers. 4to. 50 cents net. Cloth, \$1.00 net. Postage, 20 cents.
- Modern Design in Jewelry and Fans.** (Winter Number, 1901.) A sumptuous series of coloured and of black-and-white plates, illustrating the work of the most distinguished modern artists of all nationalities. Cloth, \$3.00 net. Postage, 30 cents.
- English Water Colour.** (1902.) A series of exact coloured reproductions of the most notable works in English water colour. With an introduction by Frederick Wedmore. In eight parts, 12 x 16 inches. Complete in portfolio, \$7.00 net. Express extra.
- Etching and Etchers.** (Summer Number, 1902.) A representative volume of the work of the leading Etchers and Engravers of the World. Cloth. 4to. \$5.00 net. Postage, 30 cents.
- Corot and Millet.** (Winter Number, 1902.) A survey, pictorial and textual, of the work of the two French Masters, with Essays by Gustave Geffroy and Arsène Alexandre, respectively. Cloth, \$5.00 net. Postage, 25 cents.
- Representative Art of Our Time.** (1903.) A series of Essays by eminent authorities on the various graphic arts of to-day, illustrated by 48 full-page plates in colour and otherwise, treating of Lithography, Etching and Dry-Point, Pastel, Monotyping, Wood-Engraving, Oil and Water Colour, etc., etc. In eight parts, 12 x 16 inches. Complete in portfolio, \$7.00 net. Express extra.
- Masters of English Landscape Painting.** (Summer Number, 1903.) J. S. Cotman, David Cox and Peter Dewint. A survey, pictorial and textual, of the work of these three famous Masters of Landscape, with essays respectively by Laurence Binyon, A. L. Baldry and Walter Shaw Sparrow. Cloth, \$3.00 net. Postage, 30 cents.
- Studio Art Album.** (1903.) A collection of 100 of the finest plates from the INTERNATIONAL STUDIO. Cloth-bound volume. Folio. \$5.00 net. Postage, 30 cents.
- The Genius of J. M. W. Turner, R.A.** (Winter Number, 1903.) By Robert de la Sizeranne, C. F. Bell and Walter Shaw Sparrow. Profusely illustrated in colour, etc. Cloth, \$5.00 net. Postage, 25 cents.
- The Royal Academy from Reynolds to Millais.** (Summer Number, 1904.) Edited by Charles Holme. With articles by W. K. West, Walter Shaw Sparrow and T. Martin Wood. Profusely illustrated in colour, photogravure and black and white. Cloth. 4to. \$5.00 net. Postage, 30 cents.
- Daumier and Gavarni.** (Summer Number, 1904.) The Greatest of French Humorous Draughtsmen, with a large number of photogravures, colour-plates, full-page black-and-white reproductions, etc. An essay on Daumier by Henri Frantz and an essay on Gavarni by Octave Uzanne. Large 4to. Cloth, \$3.50 net. Postage, 30 cents.
- Art in Photography.** (Summer Number, 1905.) With Selected Examples of American and European Work. Containing over 100 beautiful examples of photographic art, 16 photogravure reproductions. All illustrations mounted as separate full-page illustrations. 4to. Cloth, \$5.00 net. Postage, 35 cents.
- Mansions of England in the Olden Time.** (Winter Number, 1905.) By Joseph Nash. 104 plates. 4to. Cloth, \$5.00 net. Postage, 35 cents.
- The Royal Institute of Painters in Water Colours.** (Spring Number, 1906.) With 40 coloured plates. An account of the Institute is contributed by A. Lys Baldry. 4to. Wrappers, \$2.50 net. Cloth, \$3.00 net. Postage, 35 cents.
- The Studio Year Book of Decorative Art.** (1906.) A Guide to the Artistic Furnishing of the House. Many hundreds of illustrations including numerous coloured plates. Cloth. 4to. \$5.00 net. Postage, 35 cents.
- The Art Revival in Austria.** (Summer Number, 1906.) The subject matter of this work is treated under the following heads: I. Modern Painting. II. Modern Plastic Art. III. The Architectural Revival in Austria. IV. Decorative Art. Each division contains a large number of Illustrations in the various branches of art. Special plates reproduced in colours, and in photogravure. 4to. Price, Wrappers, \$2.50 net. Postage, 25 cents. Cloth, \$3.00 net. Postage, 35 cents.
- Old English Cottages.** (Winter Number, 1906.) 223 illustrations, 15 plates in colours. Paper, \$2.50 net. Cloth, \$3.00 net. Postage, 35c.
- The Studio Year Book of Decorative Art.** (1907.) Cloth. 4to. \$3.00 net. Postage, 35 cents.
- The Royal Scottish Academy.** (Spring Number, 1907.) Profusely illustrated with half-tone reproductions and forty coloured plates. Paper \$2.50 net. Postage, 25 cents. Cloth, \$3.00 net. Postage, 35 cents.



**JOHN LANE CO., 110-114 West Thirty-Second Street, New York**

1907

THE SPECIAL SUMMER NUMBER  
OF THE INTERNATIONAL STUDIO

# THE BROTHERS MARIS

JAMES, MATTHEW AND WILLIAM

**J**AMES MARIS, THE LEADER OF THE MODERN DUTCH SCHOOL OF LANDSCAPE PAINTING, IS ACCEPTED AS THE GREATEST AND MOST DISTINGUISHED ARTIST THE LAST CENTURY PRODUCED. HIS STURDY ROMANTICISM AND ROBUSTNESS OF TECHNIQUE ARE SUCH AS APPEAL STRONGLY TO ART LOVERS, WITH THE RESULT THAT HE HAS AN EXTENSIVE FOLLOWING OF ENTHUSIASTIC ADMIRERS.

HIS YOUNGER BROTHER, MATTHEW, IS A POET OF ANOTHER ORDER, POSSESSED OF A REMARKABLE PERSONALITY, WHO, BY HIS SUBTLE ART, HAS PRODUCED SOME MOST REMARKABLE AND FASCINATING RESULTS. FEW OF HIS WORKS HAVE HITHERTO BEEN REPRODUCED, AND THIS BOOK OFFERS AN EXCELLENT OPPORTUNITY OF STUDYING EVERY PHASE OF HIS SUBTLE ART, AS WELL AS THAT OF HIS TWO GIFTED BROTHERS.

THE NUMBER WILL CONTAIN NUMEROUS ILLUSTRATIONS OF IMPORTANT WORKS BY EACH OF THESE THREE ARTISTS, REPRODUCED WITH THE GREATEST CARE IN FACSIMILE COLORS AND BY OTHER PROCESSES. THE LETTERPRESS IS A VALUABLE CONTRIBUTION FROM THE PEN OF D. CROAL THOMSON, WHO HAS ENJOYED EXCEPTIONAL FACILITIES FOR OBTAINING MOST INTERESTING INFORMATION CONCERNING THESE THREE ARTISTS.

THIS VOLUME IS ONE OF OUR INTERNATIONAL STUDIO EXTRA NUMBERS, ISSUED IN LIMITED EDITION, AND WHEN THE PUBLICATION IS EXHAUSTED WILL NOT BE REPRINTED. THE PUBLISHERS RESERVE THE RIGHT TO ADVANCE THE PRICE AFTER THE DATE OF PUBLICATION. WE WOULD SUGGEST THAT YOU SUBSCRIBE FOR THIS WORK IN ADVANCE, SO THAT WE MAY BE ABLE TO FILL YOUR ORDER. THE PRICE WILL BE: \$2.50 NET, IN PAPER JACKETS, POSTAGE 25 CENTS; BOUND IN GREEN CLOTH, \$3.00 NET, POSTAGE 35 CENTS.

*In writing to advertisers, please mention The International Studio.*

PRESS OF REDFIELD BROTHERS, NEW YORK

# "TIFFANY FAVRILE GLASS"

MADE ONLY BY THE TIFFANY FURNACES  
LONG ISLAND, NEW YORK

The distinguishing name is Registered in the United States Patent Office, and is also protected by Letters Patent in Great Britain, France, Germany, Austria and Hungary.

Tiffany Favrile Glass exists under no other name.

Importers and Dealers are notified that the use of this name wholly or partly, in connection with any glass not made by the Tiffany Furnaces, is an infringement, and all persons so using it will be prosecuted.

*Sold in New York only by Tiffany & Co., Fifth Avenue  
and Tiffany Studios, Madison Avenue. : : : : :*

TIFFANY FURNACES

LONG ISLAND, NEW YORK

## THE MOTOR BOOK

By R. J. MCCRERY,  
Editor of "The Motor News"

*A Handbook by a well-known expert. Describes the Motor and all parts of the mechanism, the clutch and change of gear and transmission, gives valuable hints on "How to Drive," How to Take Care of the Car and all its Parts, and How to Meet Temporary Accidents and Derangements, such as Short Circuits, Loss of Power, Misfire and Explosion, Knock, Overheating, Bad Compression, etc.*

Third Edition. Profusely Illustrated. 12mo. \$1.00 net. Post, 6c.  
JOHN LANE COMPANY, 110-114 W. 32d St., New York

LONDON

OSAKA

BOSTON

## YAMANAKA & CO.

254 FIFTH AVENUE, NEW YORK

WORKS OF ART  
FROM THE FAR EAST

Rare Old Paintings and Color Prints a Specialty

## JULIUS OEHME

320-322 Fifth Avenue, New York  
N. W. Corner of 32d Street, 2d floor

*Carefully Selected Paintings*  
of the

French, Dutch, German  
& American Schools



## Frink's Portable Picture Reflectors

For electric light, meet all requirements for lighting pictures. Every owner of fine paintings could use one or more of these portable reflectors to advantage. The fact that so many have ordered the outfits for their friends is proof that their merits are appreciated. Height, closed, 51 inches; extended, 81 inches. The light from the reflector can be directed at any picture in the room and at any angle.

I. P. FRINK, 551 Pearl St., New York

GEO. FRINK SPENCER, Manager  
Telephone, 82 Worth

*The*  
**INTERNATIONAL  
STUDIO**

Reg. U. S. Pat. Off.



*Copyright, 1902, by N. E. Montross*

**JOHN LANE COMPANY**

110-114 West Thirty Second Street

• NEW YORK •

§ Monthly • 50 cts. ¢

Yearly Subscription \$5<sup>00</sup> Post paid

## Art Students' League of New York



### SUMMER SCHOOLS

Out-of-door classes in Landscape Painting under

**MR. BIRGE HARRISON**

at Woodstock, Ulster County, New York, from June 1st to October 1st.

The City Summer School will consist of classes in Drawing, Painting, Illustration, Composition, and Commercial Design under

**MR. THOMAS FOGARTY and  
MR. WALTER WALZ FAWCETT**

in the American Fine Arts Building, 215 West 57th Street, from June 3rd to September 21st.

Circulars on Application to

The Art Students' League of New York  
215 West Fifty-seventh Street, - New York, N. Y.

## HIGGINS'

DRAWING INKS  
ETERNAL WRITING INK  
ENGROSSING INK  
TAURINE MUCILAGE  
PHOTO MOUNTER  
DRAWING BOARD PASTE  
LIQUID PASTE  
OFFICE PASTE  
VEGETABLE GLUE, ETC.



Are the Finest and Best Inks and Adhesives

Emancipate yourself from the use of corrosive and ill-smelling inks and adhesives and adopt the Higgins' Inks and Adhesives. They will be a revelation to you, they are so sweet, clean and well put up.

At Dealers Generally

**CHAS. M. HIGGINS & CO., Mfrs.**

Branches: Chicago, London.

271 Ninth Street, Brooklyn, N. Y.

## New York School of Applied Design for Women

**200 WEST 23d STREET**

(Incorporated 1892)

SPECIAL LIFE CLASS. ALSO SPECIAL COURSE IN  
DESIGN UNDER ALPHONSE MUCHA

Silk and Wall Paper Designing, Antique  
and Costume Sketch Classes, Historic  
Ornament, Architecture.

Apply to **HELEN LOOMIS, Secretary**

## BACK NUMBERS

*THE (ENGLISH) STUDIO*  
Vols. I to IX inclusive. Handsome Uniform  
Cloth Binding Complete, \$100.00 net.

*THE INTERNATIONAL STUDIO*  
Vols. I—XXVII inclusive. Being Complete  
File of Bound Volumes to February, 1906,  
inclusive, \$100.00 net.

*ADDITIONAL BOUND VOLUMES*  
Vols. XXVIII, XXIX, XXX. To Complete  
File up to February, 1907, inclusive, \$3.00  
net per volume.

SEND YOUR BACK NUMBERS  
to the Publishers for Binding in Permanent  
Volume Form.

*Cloth Binding, Uniform with Series, \$1.00  
per volume.*

BEST WORKMANSHIP. MOST REASONABLE RATES

**JOHN LANE COMPANY**

110-114 WEST THIRTY-SECOND ST., NEW YORK

MR.

## WILLIAM M. CHASE

writes us as follows

"I am better pleased  
with your colors, af-  
ter a thorough test,  
than any other  
colors I have used"

Write for booklet "Ullman's  
Manual of Artists' Colors"

**SIGMUND ULLMAN  
C O M P A N Y**

Park Ave. & 146th St., N. Y.

# TIFFANY & CO.

Fifth Avenue and 37th Street, New York

## The following Advertisement from Appleton's Guide of 1863

so fully states the policy of Tiffany & Co. to-day that they reproduce it below as indicating the business methods which have characterized the house since it was founded seventy years ago

“Tiffany & Co. in calling attention to their stock, beg to present to the notice of their friends and the public the following facts: that their importations and manufactures in Gold and Silver comprise a more extensive variety than any other house in the same line; that their foreign connections, of which their Paris house is the focal centre, give them extraordinary facilities for the selection of their general stock, and the execution of special orders; that it is their determination as it is their interest, to make reasonable charges as prominent a feature of their establishment as the beauty and variety of their stock”

## Fifth Avenue New York

Tiffany & Co. 1907 Blue Book—a compact catalogue without illustrations; 621 pages of concise descriptions with range of prices of jewelry, silverware, clocks, bronzes, pottery, glassware and other objects, suitable for wedding presents or other gifts.—Blue Book sent upon request

# BUILD RIGHT

If you would know how to do this, read

## The Architectural Record

*The National Architectural Monthly*

No matter in what kind of a building you are interested, from an inexpensive bungalow to a residence costing millions, or a gigantic warehouse, you will find something in this magazine to interest you.

We will send a sample copy to any reader of THE INTERNATIONAL STUDIO.

---

---

THE ARCHITECTURAL RECORD CO., New York

# *The* AMERICAN ARCHITECT AND BUILDING NEWS

A Weekly Journal of Constructive and Decorative Art. Now in its Eighty-ninth Volume.

A sample copy will be sent on request to readers of the International Studio

We shall be pleased to send also a price list of books published by us and an illustrated catalogue of the most complete and important work on colonial architecture that has ever appeared—"THE GEORGIAN PERIOD."

THE AMERICAN ARCHITECT (INC.)

Kimbel Building,

12 West 40th Street,

New York City



# HOUSE DECORATION & FURNISHINGS



## WOOD CARVERS' TOOLS

THE GENUINE S. J. ADDIS. LONDON MAKE

Recognized by experts the world over to be the finest quality made

Send for Catalogue No. 2219, Entitled "Wood Carvers' Tools and Accessories"

**HAMMACHER, SCHLEMMER & CO.**

HARDWARE, TOOLS and SUPPLIES

NEW YORK, SINCE 1848

4th Ave. and 13th St.

## "Gewandstudien"

Studies of Flowing Draperies  
(on Female Figures)

ORIGINAL DRAWINGS BY H. FRILING

For the use of Artists, Illustrators, Designers, Glass Workers, Painters and others. Suggestions for Poster Work and Figural Compositions. 16 plates, in heliotype, containing over 40 illustrations. In portfolio, \$6.00.

**BRUNO HESSLING CO., Ltd.**

64 East 12th Street, New York, N. Y.

**VOUGA CELEBRATED FINE ART STUDIES**  
Latest complete illustrated Catalogue, 30c. New Flower, Fruit, Figure, Landscape and Animal Studies—suitable for Oils and Water Colors. Discounts given in Catalogue.

M. G. PRICE, 359 West 118th St., New York

## We Purchase Designs

For Photographic Backgrounds

Good opportunity for artists having new ideas in this direction  
*WRITE FOR PARTICULARS*

**ROBEY-FRENCH COMPANY**

34 Bromfield Street, Boston, Mass., U. S. A.

## The Country Cottage

BY G. L. MORRIS AND ESTHER WOOD

16mo, cloth, \$1.00 net; leather, \$1.25 net. Post. 5c.

*The Country Gentleman* says:

"An interesting little book, beautifully illustrated, has 73 half-tones, showing many different styles of cottages, with plans for building them. Unlike many books of this kind, it is written in an interesting way that quite inspires one with the wish to build a cottage like some of those described."

Other volumes in the Country Handbook Series include Sailing, Kennel and Fisherman's handbooks, etc. Send for list.

**JOHN LANE COMPANY, 110-114 W. 32d St., New York**



**Long Sang Ti & Co.**  
IMPORTERS

307 FIFTH AVENUE, Near 31st St.  
NEW YORK

Genuine Chinese and Japanese  
Objects of Art

Real Chinese Jade & Oriental Jewelry

*Write for Illustrated Booklet A*



**Misses Whittredge & Barrows**

Interior Decoration

General Decorative Work & Designing

4 WEST 40th STREET, NEW YORK CITY



**THE UNIVERSITY PRINTS**

1,500 subjects on Greek and Italian art. Size 5 1/2 x 8 inches. One cent each or eighty cents per hundred. *Send for Catalogue.*

Dutch, Flemish and German Series in preparation.

Bureau of University Travel, 16 Trinity Place, Boston, Mass.

*In writing to advertisers, please mention The International Studio.*

# GARDEN AND LAWN FURNISHINGS

## METAL GARDEN ORNAMENTS

### Lawn and Park Fountains

Aquaria, Drinking Fountains, Flower  
Vases, Statuary, Settees and  
Chairs, Sun Dials

CATALOGUES ON APPLICATION

Address: ORNAMENTAL DEPT.



Copyright, 1903, by The J. L. Mott Iron Works.

**THE J. L. MOTT IRON WORKS, Fifth Avenue and 17th Street, New York**



## SUN DIALS

with or without PEDESTALS

Send for illustrated Price List K

Hartmann Bros. Mfg. Co.

New York Office, 1123 Broadway

Mount Vernon, N. Y.

# ROCK *and* WATER GARDENS

By **CHARLES THONGER**

Author of "The Book of Garden Furniture,"  
"The Book of Garden Design," etc.

LATEST ISSUE IN THE HANDBOOKS  
OF PRACTICAL GARDENING SERIES

12mo. Illustrated. \$1.00 net. Postage, 6c.

#### CHAPTERS

ROCK GARDEN CONSTRUCTION  
ROCK GARDEN IN SPRING  
ROCK GARDEN PLANTS  
ROCK GARDEN SHRUBS  
WILD WATER MARGINS  
SMALL WATER GARDENS  
BOG AND MARSH GARDENS  
LILY TANKS  
WATER LILIES  
AQUATICS AND BOG PLANTS  
ROCK AND ALPINE GARDENS

**JOHN LANE COMPANY**

110-114 West 32d Street, NEW YORK

# THE STABLE

## HANDBOOK

By *T. F. DALE*

Full Particulars for the  
Guidance of Owners of  
Moderate Means.



With 32 Half-Tone  
Illustrations of the Best  
Types of Hunter, Thoroughbred, Hackney, Trotter,  
Harness Horse, Pony, Brood Mare, etc. To-  
gether with 10 Plans Showing Skeleton, Parts of  
Foot, Legs, Teeth, etc.

16mo. \$1.00 net. Postage 6c.

#### CHAPTERS

**THE STABLE**

**FORAGE**

**HUNTERS**

**THE HARNESS HORSE**

**HORSES AT GRASS**

**SIMPLE REMEDIES, etc.**

"Everything in the book," says the author,  
"is the result of the personal experience of  
one who has always loved horses and had to  
consider ways and means. I have tried to put  
down only what I have proved to be useful,  
and to consider what counsels would have been  
most profitable to myself as a beginner in the  
practice of horsemanship."

**JOHN LANE COMPANY**

110-114 West 32d Street, NEW YORK

SAINT LOUIS

PHILADELPHIA

BALTIMORE

We are the

# Oldest Manufacturers, Importers *and* Dealers in Artists' Materials, Draughtsmen's and Engineers' Supplies

*Established 1854. Recommended by Prominent Artists.*

F.W. & Co.'s finest prepared Oil and Moist Water Colors, Canvases (for oil and pastel color painting), Soft and Half-hard Pastels, Pastel Papers and Boards, Water-proof Drawing Inks.

Artists' finest Red Sable, Russian Sable, Bristle, Ox-Hair and Camel Hair Brushes. Photo Retouching Tints

— Red No. 1, Brown No. 2, Black No. 3. In tubes, size 2 x ½ inches, each 25c.

Blanc D'Argent and Photo White. The only Whites that will stand the test.

Air Brushes, Air Brush Materials. F.W. & Co.'s Air Brush Lamp Black in tubes. All of F.W. & Co.'s moist Water Colors are used in the Air Brush.

China Paints and China Painters' Materials.

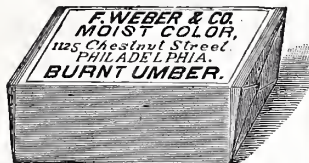

Harbutt's Plasticine. A new composition Clay. Read what the leading Sculptors say about it. Modelling Tools, all shapes, all sizes, all kinds.

Materials for Illustrators, Designers, Fresco Painters, Sculptors, Textile Workers, Engravers and Lithographers.

Blue Process Papers, Detail and Tracing Papers, Drawing Papers, T-Squares, Triangles, etc., etc.



Sole Agents for Riefler's Round System Instruments. Works on Art for Illustrators, Fresco Painters, Sculptors, Engravers, Textile Workers and Lithographers.

*Write for Complete Catalogue, Vol. 263*

## F. WEBER & Co., 1125 Chestnut Street, Philadelphia, Pa.

Branch Houses: ST. LOUIS, 709 Locust St. BALTIMORE, 227 Park Ave.

"THE MOST COMPLETE AND VALUABLE WORK EVER ISSUED ON ANY CRAFT."

## PLAIN—PLASTERING—DECORATIVE

A PRACTICAL TREATISE ON THE ART AND CRAFT OF PLASTERING AND MODELLING  
New Revised Edition. By WILLIAM MILLAR, Plasterer and Modeller

Illustrated by Fifty-five Full-Page Plates, and Five Hundred smaller Illustrations in the Text

Large 4to (11 ins. by 8½ ins.), containing 630 pages, strongly bound in canvas. \$7.50 net (Express Extra)

Some topics treated in this unique and indispensable book:

### HISTORY OF PLASTER WORK

#### MATERIALS:

Plaster of Paris, Lime, Mastic, Hair, Cements of all descriptions, with a complete account of

#### PORTLAND CEMENT

#### DECORATIVE CEILINGS

#### MOULDINGS: RUNNING, DIMINISHED AND CIRCULAR

#### EXTERIOR PLASTERING:

Instructions for making Facades in Portland Cement and in Colors, Fresco, Fresco Secco, etc.

#### MODELLING:

Basic Principles. Proportions of Human Body. Tools for Clay Working. Modelling in Cement, Wax, Tow, etc.

#### MOULDING AND CASTING:

How to Make Moulds, cast in Plaster, Wax, etc., etc.

#### GELATINE MOULDING

#### FIBROUS PLASTER WORK

#### COMPOSITIONS:

Papier Maché, Stage Properties. Carton Pierre. Sulphur Moulds.

#### GEDSO:

Method of Preparation and Application.

#### GEDSO DURO

#### GEDSO GROSSO

#### GEDSO SOTTILE

Method of Making and Manipulating. Full Recipes for Mixing, etc., etc.

#### SCAGLIOLA

#### FOREIGN PLASTER WORK:

Saracenic, Persian, Spanish, Moorish, Indian, Chinese, Italian, French, German, Austrian, Belgian, Russian, English, Scotch, Irish.

#### TERRA COTTA

#### PLAIN CONCRETE

#### REINFORCED CONCRETE:

Concrete and Iron, Concrete and Wood, Steel Concrete.

#### CONCRETE GARDEN FURNITURE

#### ARCHITECTURE

Elements applied to Plaster Work.

#### TOOLS AND APPLIANCES

## JOHN LANE COMPANY, 110-114 West 32d Street, NEW YORK



## "VIGNETTE"

### THE WATER COLOR BRUSH ATTACHMENT

*That enables you to do  
with ease what was  
difficult before*

**A** PATENTED attachment of Aluminum Adjustable to Any Brush in a moment of time, which greatly facilitates Wash Drawing, Landscape Painting, Figure Studies, etc.

**A GREAT AID TO THE EXPERIENCED ARTIST**

**A MARVELOUS HELP TO THE AMATEUR**

It supplements the Double End Brush in a very superior way, a slight movement of the hand being all that is necessary to bring the brush with water into play, thus enabling one to gradate colors and washes in a very satisfactory manner. New brushes supplemented without impairing the attachment.

Made in three sizes (small, medium and large) to accommodate any brush. 35c. each. The three sizes for \$1.00, postpaid.

**J. W. HAWKINS**

121 Union Avenue, - PASSAIC, N. J.

Liberal Discount to Art Schools and Agents



No. 1007

**COLONIAL MIRRORS OF ALL PERIODS**

*Illustrated Catalogue Free*

**FOSTER BROTHERS, 4 Park Square, Boston**

## PLASTER CASTS



*Special  
Reduced Prices*

Antique, Mediæval  
and Modern Statuary.  
Suitable for the  
Decoration of Halls,  
Living-Rooms, Dens,  
Libraries and Studios.

Decorative and  
Architectural Casts  
for Schools, Colleges,  
Libraries, Art Classes.

*"The eye must be trained. We cannot know history without going to the records. We can never know Art unless we accustom the eye to the beauty of form."*

For Full Particulars of this Special Offer Address:

**INTERNATIONAL STUDIO**

JOHN LANE CO., 110-114 W. Thirty-Second St., New York

## THE MOTOR BOOK

By **R. J. MECREDDY,**  
Editor of "The Motor News"

*¶ A handbook by a well-known expert. Describes the Motor and all parts of the mechanism, the clutch and change of gear and transmission, gives valuable hints on "How to Drive," How to Take Care of the Car and all its parts, and How to Meet Temporary Accidents and Derangements, such as Short Circuits, Loss of Power, Misfire and Explosion, Knock, Overheating, Bad Compression, etc.*

**Third Edition. Profusely Illustrated  
12mo. \$1.00 net. Post, 6c.**

**JOHN LANE COMPANY  
110-114 W. 32d Street, New York**

# The International Studio

Copyright, 1907, by John Lane Company

---

## CONTENTS, AUGUST, 1907

---

THE WORCESTER ART MUSEUM. By Leila Mechlin. Twelve Illustrations . . . . .	xxxix
FLOOR COVERING IN SUMMER—MATTING. Five Illustrations . . . . .	1
TWO TYPES OF THE CALIFORNIA PATIO. By Henrietta P. Keith. Four Illustrations . . . . .	lvi
LACE AND LACE MAKING AT PRATT INSTITUTE. By Eva Lovett. Seven Illustrations . . . . .	lviii
THE "MARIE ANTOINETTE" SHAWL. Two Illustrations. . . . .	lxi
THE GARDEN CITY AND ITS UNITS. Three Illustrations . . . . .	lxiv
POSSIBILITIES OF CLAY. By Charles F. Binns. Seventeen Illustrations . . . . .	lxvi
EUROPEAN SECTION:	
THE PAINTINGS OF MR. CHARLES SIMS. By A. Lys Baldry. Eleven Illustrations . . . . .	89
A PAINTER OF GARDENS: SANTIAGO RUSINOL. By Vittorio Pica. Eleven Illustrations . . . . .	98
LOUIS GILLOT, PAINTER AND ENGRAVER. By Henri Frantz. Seven Illustrations . . . . .	105
BITS OF OLD CHINA. By Inglis Sheldon-Williams. Five Illustrations . . . . .	111
NOTES ON SOME POLISH ARTISTS OF TO-DAY. Fifteen Illustrations . . . . .	115
THE SALON OF THE SOCIETE NATIONALE DES BEAUX-ARTS. Nine Illustrations . . . . .	126
TALASHKINO: PRINCESS TENISHEF'S SCHOOL OF RUSSIAN APPLIED ART. By C. de Danilovicz. Ten Illustrations . . . . .	135
REVIEWS AND NOTICES . . . . .	167
THE LAY FIGURE . . . . .	170
STUDIO TALK:	
(From our own Correspondents):	
LONDON. Six Illus. . . . .	140
VIENNA. Fourteen Illus. . . . .	148
BERLIN. Five Illus. . . . .	155
DRESDEN. Five Illus. . . . .	158
PARIS . . . . .	160
STOCKHOLM. Three Illus. . . . .	161
FLORENCE. Three Illus. . . . .	163

### COLOR INSERTS:

- A Tinted Reproduction of the Painting by Carleton Wiggins, entitled "The Leader of the Herd."
- A Tinted Reproduction of the Painting by Willard L. Metcalf, entitled "Kalmia."
- A Reproduction in Colors of an Oil Painting, by Charles Sims, "Sunshine and Wind."
- A Reproduction in Colors of an Oil Painting, by E. L. Gillot, "Le Depart de Marine."
- A Reproduction in Colors of a Painting, by Theodore Axentowicz, "A Ruthenian Peasant Girl."
- A Reproduction in Colors of an Oil Painting, by Edith Helena Adie, "Herbaceous Border at Kent."
- A Reproduction in Colors of a Painting, by J. B. C. Corot, "The Quiet River."
- A Tinted Reproduction from a Chalk Drawing, by Vittorio Guaccimanni.

---

**CHANGE OF ADDRESS** *Subscribers desiring to register change of address must notify the publishers on or before the 10th of the month. Please be sure to give FORMER ADDRESS also.*

# Art Tuition

## Worcester Art Museum ARTS and CRAFTS SHOP

Fully equipped for metal work and enamelling. A school of design and metal work will be opened September 30, 1907.

### INSTRUCTORS:

MISS KATHERINE B. CHILD, Assistant in Design in the school of the Museum of Fine Arts, Boston.

GEORGE J. HUNT, Instructor in Metal Work in the school of the Museum of Fine Arts, Boston.

Lecturer on Design, C. HOWARD WALKER, Boston.

Tuition, \$10.00 for each term of ten weeks, or \$25.00 for the full course of thirty weeks.

### BENCH ROOM TO PROFESSIONALS

at reasonable rates, with a reduction for groups of five or ten.

Rooms will be open from 8 A.M. to 9 P.M.

The City of Worcester is about forty miles from Boston, beautifully situated among the hills of Massachusetts.

Cheaper board can be obtained than in large cities.

For information address Mrs. Edith Loring Getchell, 8 Linden Street, Worcester, Mass.

## School of Industrial Art OF THE PENNSYLVANIA MUSEUM BROAD AND PINE STREETS, PHILADELPHIA

Thorough work under trained specialists  
in all branches of Fine & Industrial Art

Special provision for classes in Illustration, Architecture, Decorative Painting, and Sculpture, Pottery, Metal Work, Industrial Design, Textile Design and Manufacture.

L. W. MILLER, Principal

### MISS EMILIE C. ADAMS MINIATURES

Portraits and Figures on Porcelain and Ivory. Decorative work in both Mineral Painting and Water Color

Studios: 745 Third Ave., Lansingburgh, N. Y.  
and at the Emma Willard Art School, Troy, N. Y.

# Art Tuition

## Troy School of Art and Crafts TROY, N. Y.

EMILIE C. ADAMS, Director

Cast Drawing, Drawing and Painting from Costume Models. Illustration, Composition, Anatomy, Decorative Design, Oil and Water Color, Wood Carving, Metal Work, Leather Carving, Modeling, China Painting. For further information address

Miss EMILIE C. ADAMS, 853 Second Ave., Upper Troy, N. Y.

## OUT-DOOR SKETCHING CLASS

Point Pleasant, New Jersey.

From June 1st till October 1st

Out-door figure study a specialty. Pupils can work in any medium.

Address for full particulars. MISS ROSALIE PALMIÉ

Point Pleasant, N. J.

## ART ACADEMY OF CINCINNATI

ENDOWED Complete Training in Art SCHOLARSHIPS

Drawing, Painting, Modeling, Composition,  
Anatomy, Wood Carving, Decorative Design  
applied to porcelain, enamels, etc.

FRANK DUVEINECK  
V. NOWOTNY  
L. H. MEAKIN

C. J. BARNHORN  
WM. H. FRY  
ANNA RIIS

HENRIETTA WILSON  
KATE R. MILLER  
W. E. BRYAN

40th YEAR: SEPT. 23, 1907, to MAY 23, 1908 - - \$25.00

J. H. GEST, Director, - - CINCINNATI, OHIO

## COLUMBUS ART SCHOOL

Excellent facilities for the study of Drawing, Painting, Modeling, Design and Illustration. Twenty-ninth year begins September 30, 1907. Write for catalogue to JOHN E. HUSSEY, Director, Columbus, Ohio.

# ART STUDENTS

The Publishers of THE INTERNATIONAL STUDIO make the following special offer to Art Students

## THREE MONTHS TRIAL SUBSCRIPTION FOR ONE DOLLAR

THE INTERNATIONAL STUDIO is the Standard Art Magazine. It records and reflects with authoritative articles by skilled critics and with an unsurpassed abundance and quality of illustrations in color, tint, black and white, and line, all the important art movements of the day in this country and in Europe. It does not pretend to be a student's magazine in the sense of concerning itself more or less exclusively with student affairs. It is simply the indispensable periodical for those art students who are genuinely in earnest and care to keep in touch with the work being done by the leading artists of the day. So valuable has it become that a subscription to it is considered by educators to be a liberal course in art study.

"ART IS LONG"—WELL CHOSEN READING IS A LONG STEP FORWARD

THE MAGAZINE SPEAKS FOR ITSELF. TRY IT

# WANTED

NOTE TO SUBSCRIBERS. The publishers of the INTERNATIONAL STUDIO will buy in copies of the following issues in good condition. These issues having become rare will be bought at 50 cents a copy, though issued at the old rate (35 cents.)

1899. January, February, October, November, December

1900. January

1903. March, December

1904. January, June, August, October

The publishers offer this advanced rate to complete sets with the above numbers which have been in special demand. If you have any such copies which you do not need, address

JOHN LANE COMPANY

110-114 WEST 32d STREET, NEW YORK

# Art Tuition

## ART SCHOOL

Awarded International Silver Medal at St. Louis, 1904

Term: October 1—June 1. For Beginners and Advanced Students.

Design, Modeling, Wood-carving,  
Cast and Life Drawing,  
Water-Color and Painting;  
Evening Class in Costume Drawing.

Instructors:

SOPHIA ANTOINETTE WALKER, HELEN M. TURNER

Young Women's Christian Association,  
7 East 15th St., New York.

Office Hours: 9 A.M. to 5 P.M. and 7 to 9 P.M.

## Eric Pape School of Art

Tenth Year—October 1, 1907, to June 1, 1908.

Head Instructor and Director, ERIC PAPE

No examinations for admission to any of the classes. Students begin by drawing from the nude and costume models as is done in the Paris academies upon which the school is modeled. Fine large studios.

Drawing, Painting, Composition  
Illustration and Decorative Design

Drawing and Painting from "life," separate classes for men and women. Portraiture, Still-life, Flower-painting, Water-color, Pastel, Composition, Decorative Design and Painting, Practical Design of Textiles. Illustration Pen, Wash, Gouache, Poster and Book cover designing.

Morning, Afternoon and Evening Classes. Scholarships, Medals and Prizes.

For Illustrated Circulars address the Secretary  
Corner Massachusetts Ave. and Boylston St., Boston, Mass.

## A THOROUGHLY MODERN School of Arts and Handicrafts

Finely Equipped Shops and Expert Instruction in METAL WORKING, BOOKBINDING, WOOD CARVING, MODELING, LEATHER WORKING, POTTERY.

Three Year Courses in Fine Art, Decorative Art, Normal Art, Architecture.

Four Free Scholarships Awarded Yearly. Cash Prizes.  
For illustrated circular, address

THEO. HANFORD POND, Supt.

Department of Applied and Fine Arts  
MECHANICS INSTITUTE, ROCHESTER, N. Y.

## THE MISSES MASON

Studio: 48 East 26th Street, New York

Classes in  
Design, Decoration of Porcelain  
Catalogue on Request

In writing to advertisers, please mention The International Studio.

# Art Tuition

## The New York School of Art

2237-2239 BROADWAY, NEW YORK CITY

SUMMER TERM

SUMMER CLASSES IN THE CITY, May 15 to Sept. 8, 1907

Instructors—ERNEST LAWSON, KENETH HAYES MILLER  
FRANK ALVAH PARSONS, GRACE D. LYNN

Daily Classes—Life, Portraiture, Still Life, Illustration, Composition and Design. Open Air Classes under Ernest Lawson.

EUROPEAN SUMMER CLASS

HOLLAND, BELGIUM, FRANCE AND ITALY

Instructors—ROBERT HENRI, DOUGLAS JOHN CONNAH

Leaving New York June 15th and June 25th, the latter date for the convenience of teachers of art. Special rates for those not studying. For rates and further particulars address

DOUGLAS JOHN CONNAH, President

## TEACHERS COLLEGE

COLUMBIA UNIVERSITY, NEW YORK

OFFERS 185 Courses of Instruction, including the Theory and Practice of Teaching Art—Principles of Design—Drawing, Painting and Illustration—Clay Modeling—Design in Construction and Decoration—Interior Decoration—the History and Appreciation of Art.

Announcement for 1907-8 Now Ready

ARTHUR V. DOW, Director, Department of Fine Arts  
JAMES E. RUSSELL, LL.D., Dean

## The Art Institute ART SCHOOL of Chicago

W. M. R. French, Director N. H. Carpenter, Secretary

Study art under the most favorable conditions in this country—in the Art Institute with its art galleries, permanent collections, passing exhibitions, lecture courses, libraries, and constant association with accomplished artists and teachers.

Drawing, Painting, Illustrating, Normal Instruction, Sculpture, Decorative Design and Architecture. Students may enter at any time. No art student, east or west, ought to select his school until he has seen the fine illustrated catalogue of the Art Institute, mailed free on application.

Be careful of the name, the Art Institute.

RALPH HOLMES, Registrar

Dept. P., Art Institute

CHICAGO, ILL.

## The London School of Art

Stratford Road, Kensington, W., London, England

Drawing, Painting, Composition, Illustration, Etching

Teaching Staff { JOHN M. SWAN, R. A.  
FRANK BRANGWYN, A. R. A.  
G. SPENCER WATSON  
ARTHUR S. COVEY

SUMMER CLASS IN LUXEMBOURG

Membership is limited in all classes and students will be admitted in the order of their application whenever a vacancy occurs.

For further particulars, apply to

C. P. TOWNSLEY, Director

## New York School of Industrial Art

343 WEST 57TH ST.: A PROFESSIONAL SCHOOL of DESIGN

Architecture, Interior Decoration; Textile, Costume & Commercial Design; Art Crafts. Teachers of these Subjects Thoroughly Trained.

ELISA A. SARGENT, President.

*"Of the same type as Theodore Roosevelt"*

## RIFLE AND ROMANCE IN THE INDIAN JUNGLE

Being the Record of Thirteen Years of Indian Jungle Life. By Capt. A. I. R. GLASFURD (Indian Army).

"As sound and readable a book as we have seen for many a day. Captain Glasfurd is a great hunter and also an artist who has sketched the beasts of the jungle, imparting to them life and vigor which only the sportsman can interpret."—*The Athenaeum*.



With numerous Illustrations by the Author and reproductions from Photographs. 8vo. \$2.50 net. Postage, 18 cents.

"An enthusiastic sportsman of the right sort. . . . As varied a literary feast as could well be contrived on one general topic. . . . A sportsman-naturalist-writer of the same type as Theodore Roosevelt, Caspar Whitney and C. G. Shillings."—*New York Tribune*.



## ORNITHOLOGICAL AND OTHER ODDITIES



By FRANK FINN, B.A. (Oxon), F.Z.S., of the Indian Museum, Calcutta.

With numerous Illustrations from Photographs. 8vo. \$5.00 net. Postage, 25 cents.

*In this book Mr. Finn deals with various out-of-the-way subjects connected with the study of living birds and other animals, with a freshness of touch which is the outcome of an unusually wide experience of living Nature in more countries than one.*

## BRITISH MALAYA

An Account of Anglo-Saxon Influence in the Far East. By SIR FRANK ATHELSTANE SWETTENHAM. Numerous Illustrations and a Map. 8vo. \$4.50 net. Postage, 22 cents.

*The author traces the history of European enterprise in Malaya from the earliest times, describes the Malays, their country, language, characteristics and customs with a knowledge and detail not to be found in any other publication in the English language.*

"Were the applicants for positions in our Philippine civil service obliged to pass an examination to prove their fitness, 'British Malaya' would be an invaluable text-book."—*New York Evening Post*.

## BOMBAY DUCKS

By DOUGLAS DEWAR, B.A., F.Z.S., I.M.S.

*An account of some of the Everyday Birds and Beasts found in a Naturalist's El Dorado.*

With numerous Illustrations reproduced from Photographs by Captain Fayrer, I.M.S. 8vo. \$5.00 net. Postage, 20 cents.



## FROM FOX'S EARTH TO MOUNTAIN TARN

By J. H. CRAWFORD.

Days among the Wild Animals of Scotland. With numerous Illustrations. 8vo. \$3.50 net. Postage, 18 cents.

*A valuable contribution to natural history, with Photographs from life.*

"Will appeal to every one who appreciates the charm of life in the open."—*New York Tribune*.

"Really wonderful photographs."—*Philadelphia Public Ledger*.



## A CRUISE ACROSS EUROPE

By DONALD MAXWELL

Notes on a Freshwater Voyage from Holland to the Black Sea, with nearly two hundred Illustrations by the author and Cottingham Taylor. 8vo. \$3.00 net. Postage, 22 cents.

"A very unusual journey."—*New York Sun*.

"A lively trip delightfully entertaining."—*New York Tribune*.

**JOHN LANE CO., 110-114 West 32d Street, NEW YORK**



# ARTISTS' MATERIALS

## F.W. Devoe & Co.'s

### Artists' Tube Colors

CANVAS, ACADEMY BOARDS,  
FINE BRUSHES FOR OIL AND  
WATER-COLOR PAINTING, etc.

"THE STANDARD QUALITY"

*Everything in Artists' Materials*

## F.W. DEVOE & C.T. RAYNOLDS CO.

Fulton Street, cor. William  
NEW YORK

176 Randolph Street  
CHICAGO

The Largest Manufacturers and Importers of Artists' Materials  
in the United States

## WM. H. POWELL

Fine Art Gallery, 983 6th Ave., New York

### ARTISTS' MATERIALS

New York Agent for LEFEBVRE-FOINET and  
EDOUARD of Paris

And BLOCKX'S HAND-GROUND, PERMANENT BEL-  
GIAN OIL COLORS and AMBER VARNISH, BEST IN  
THE WORLD, French Canvas and Brushes. Mail Orders have  
prompt attention.

PICTURE FRAMING A SPECIALTY

A WONDERFUL INVENTION!

## ALGUMAR WATER COLORS

BLEND LIKE OIL. DO NOT RUN

Picture upright. No waiting for washes  
to dry. Full instructions free

A. G. Marshall, Thousand Island Park, N. Y.

## PYROPEN

Leading Instrument in Pyrography. Heated by GAS. No Benzine  
or Bellows. All Art Material Dealers, or post-paid for \$1.00 from  
WISEMAN MFG. CO., 147 W. 26th Street, New York

*In writing to advertisers, please mention The International Studio.*

## A. Sartorius & Co.

Manufacturers and Importers of

### Artists' Colors and Materials

#### China Colors in Powder

(In vials or in bulk.) Vials and corks for dealers and teachers  
bottling china colors.

#### China Colors in Tubes

(Oil and Water Preparation.)

#### Artists' Oil Colors, Artists' Water Colors, Artists' Moist Oleo Colors, Artists' Fine Brushes

Write for A. Sartorius & Co.'s Catalogue containing many  
instructions how to mix and apply colors.

45 Murray Street, New York

For a smooth writing, easy  
working pen—use the  
Spencerian  
Steel  
Pen

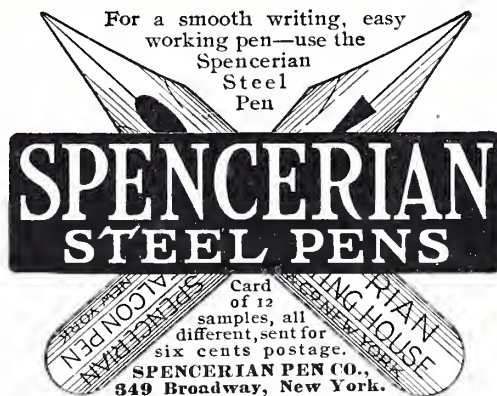

**SPENCERIAN  
STEEL PENS**

Card  
of 12  
samples, all  
different, sent for  
six cents postage.  
SPENCERIAN PEN CO.,  
849 Broadway, New York.

## DRAWING PENCIL PERFECTION

IN ELEVEN GRADES OF HARDNESS

Send 16 cents for generous samples of  
Dixon's American Graphite Artists' Pencils

JOSEPH DIXON CRUCIBLE CO., Jersey City, N.J.

AD. XI

1907

THE SPECIAL SUMMER NUMBER  
OF THE INTERNATIONAL STUDIO

# THE BROTHERS MARIS

JAMES, MATTHEW AND WILLIAM

**J**AMES MARIS, THE LEADER OF THE MODERN DUTCH SCHOOL OF LANDSCAPE PAINTING, IS ACCEPTED AS THE GREATEST AND MOST DISTINGUISHED ARTIST THE LAST CENTURY PRODUCED. HIS STURDY ROMANTICISM AND ROBUSTNESS OF TECHNIQUE ARE SUCH AS APPEAL STRONGLY TO ART LOVERS, WITH THE RESULT THAT HE HAS AN EXTENSIVE FOLLOWING OF ENTHUSIASTIC ADMIRERS.

HIS YOUNGER BROTHER, MATTHEW, IS A POET OF ANOTHER ORDER, POSSESSED OF A REMARKABLE PERSONALITY, WHO, BY HIS SUBTLE ART, HAS PRODUCED SOME MOST REMARKABLE AND FASCINATING RESULTS. FEW OF HIS WORKS HAVE HITHERTO BEEN REPRODUCED, AND THIS BOOK OFFERS AN EXCELLENT OPPORTUNITY OF STUDYING EVERY PHASE OF HIS SUBTLE ART, AS WELL AS THAT OF HIS TWO GIFTED BROTHERS.

THE NUMBER WILL CONTAIN NUMEROUS ILLUSTRATIONS OF IMPORTANT WORKS BY EACH OF THESE THREE ARTISTS, REPRODUCED WITH THE GREATEST CARE IN FACSIMILE COLORS AND BY OTHER PROCESSES. THE LETTERPRESS IS A VALUABLE CONTRIBUTION FROM THE PEN OF D. CROAL THOMSON, WHO HAS ENJOYED EXCEPTIONAL FACILITIES FOR OBTAINING MOST INTERESTING INFORMATION CONCERNING THESE THREE ARTISTS.

THIS VOLUME IS ONE OF OUR INTERNATIONAL STUDIO EXTRA NUMBERS, ISSUED IN LIMITED EDITION, AND WHEN THE PUBLICATION IS EXHAUSTED WILL NOT BE REPRINTED. THE PUBLISHERS RESERVE THE RIGHT TO ADVANCE THE PRICE AFTER THE DATE OF PUBLICATION. WE WOULD SUGGEST THAT YOU SUBSCRIBE FOR THIS WORK IN ADVANCE, SO THAT WE MAY BE ABLE TO FILL YOUR ORDER. THE PRICE WILL BE: \$2.50 NET, IN PAPER JACKETS, POSTAGE 25 CENTS; BOUND IN GREEN CLOTH, \$3.00 NET, POSTAGE 35 CENTS.





THE LEADER OF THE HERD  
BY CARLETON WIGGINS

# The INTERNATIONAL STUDIO

VOL. XXXII. No. 126

Copyright, 1907, by John Lane Company

AUGUST 1907

## THE WORCESTER ART MUSEUM BY LEILA MECHLIN

AT A time when the woods and streams are most winsome, when mountain and sea exert their utmost charm, and the attraction of indoor pleasures is greatly discounted, the Worcester Art Museum has for ten successive years set forth an exhibition of contemporary oil paintings which has ranked with the best. It is, of course, easier to obtain the loan of good paintings in the summer when the art season is at lowest ebb, but it

is not for this reason alone that the directors of this Museum have chosen the period from May to September to hold their most important show. Worcester, Massachusetts, is on the direct route of northern travel and in the heart of the district given over to summer resorts. These months, therefore, increase her radius of influence and afford unusual opportunity for the diffusion of art knowledge. But let it not be thought that the purpose of the Worcester Art Museum is merely to attract wide attention, or profit first the outside world, for it was founded expressly for the benefit of the people of



NORTH FRONT  
SHOWING MAIN ENTRANCE

WORCESTER ART MUSEUM  
WORCESTER, MASS.

## *Worcester Art Museum*

Worcester and has been upbuilt and sustained entirely by residents of that city. Indeed it seems to have been called forth by the need of the people and to stand more truly as a monument to voluntary coöperation and civic pride than almost any other institution in our land.

Its beginning is especially interesting. On February 26, 1896, the late Stephen Salisbury invited a number of men and women to meet at his home to discuss and arrange for the organization of an art museum for the promotion of art and art education in Worcester, and at that meeting the Museum corporation was formed. Mr. Salisbury himself gave at that time the site for the Museum and one hundred thousand dollars, half of which was to go toward the erection of a building and half toward its maintenance. No time was lost. A building committee was appointed, other museums visited and inspected, and before the following October a plan had been determined upon and Stephen C. Earle had been appointed architect. Realizing that the success of the Museum was in the hands of the peo-

ple, the directors early, and with shrewd insight, sought the active coöperation of the citizens of Worcester. The building and its equipment as planned would cost about one hundred thousand dollars and only half of this amount had been given. An appeal was made by a special committee through the press and subscriptions poured in. Within two years forty thousand dollars were received in subscriptions varying from five cents to three thousand dollars in amount. The cornerstone of the building was laid on June 24, 1897, and the Museum was opened with a loan exhibition, arranged through coöperation with the Worcester Art Society, on May 10, 1898. Then began the work of acquisition and again evidence was given that the people of Worcester looked upon the Museum as a common possession and trust. Individuals and organizations seem to have vied with one another in generosity, and the choice of gifts was most judiciously made. The Museum's collection of casts, which is especially notable, was almost entirely acquired in this way. The bank clerks of



THE FAMILY OUTDOORS

BY GUSTAVE CIMIOTTI, JR.



*Permanent Collection Worcester Art Museum*

PORTRAIT OF  
MRS. PEREZ MORTON  
BY GILBERT STUART  
(1827-28)

## Worcester Art Museum

Worcester gave *Hermes Resting*; the newspapers, the *Ludovisi Mars*; the Board of Trade, *Augustus of the Vatican*; the physicians, *Apollo Belvedere*; the lawyers, *Sophocles*; the employees of a manufacturing company, *Mercury*; the Art Society, the *Venus of Milo*; the Woman's Club, the *Victory of Samothrace*; the Quinsigamond Boat Club, the *Warrior of Agassiz*; the Foresters, *Tomb of Lorenzo di Medici*; the Hancock Club, *Demosthenes*, and the Swedish citizens, the *Wrestlers*. Thus is shown the breadth of interest aroused and the democracy of the movement. There were, of course, many individual gifts, some of which were of great value, but they were less significant than those made by the widely separated groups. This beginning was more auspicious and should be found suggestive. Every one who gave derived through his, or her, gift a personal interest in the welfare of the Museum and a part ownership in its success. Perhaps this fact, and that

most of the givers were working people, explain why out of an annual attendance of between eighty-seven and eighty-nine thousand at least twenty-one thousand admissions are on Sunday afternoons—that is, about one-fourth of the entire number.

In the autumn of 1898 a school of art was organized at the Museum, with classes in painting and drawing and decorative design. These classes have been kept up uninterruptedly and to them have been added free night classes for both men and women. The instructors for the coming year are Mr. Philip Hale, Mr. Herman Dudley Murphy, Mrs. Katherine B. Child and Mr. George J. Hunt; and of these Mr. Hale and Mr. Murphy have been associated with the school since its inception. The average enrolment of students is still comparatively small, but the results obtained have been good and the outlook is promising.

Almost unprecedented power and opportunity came to the Worcester Art Museum with the munificent bequest of the late Stephen Salisbury who, dying in November, 1906, made it residuary legatee to real and personal property aggregating over four million dollars in value. This placed it immediately among the wealthiest museums in this country and laid a heavy responsibility upon its board of directors—a body of twelve men selected from the members of the corporation. The will was contested and a decision was rendered in favor of the Art Museum only a few months ago. Even now the

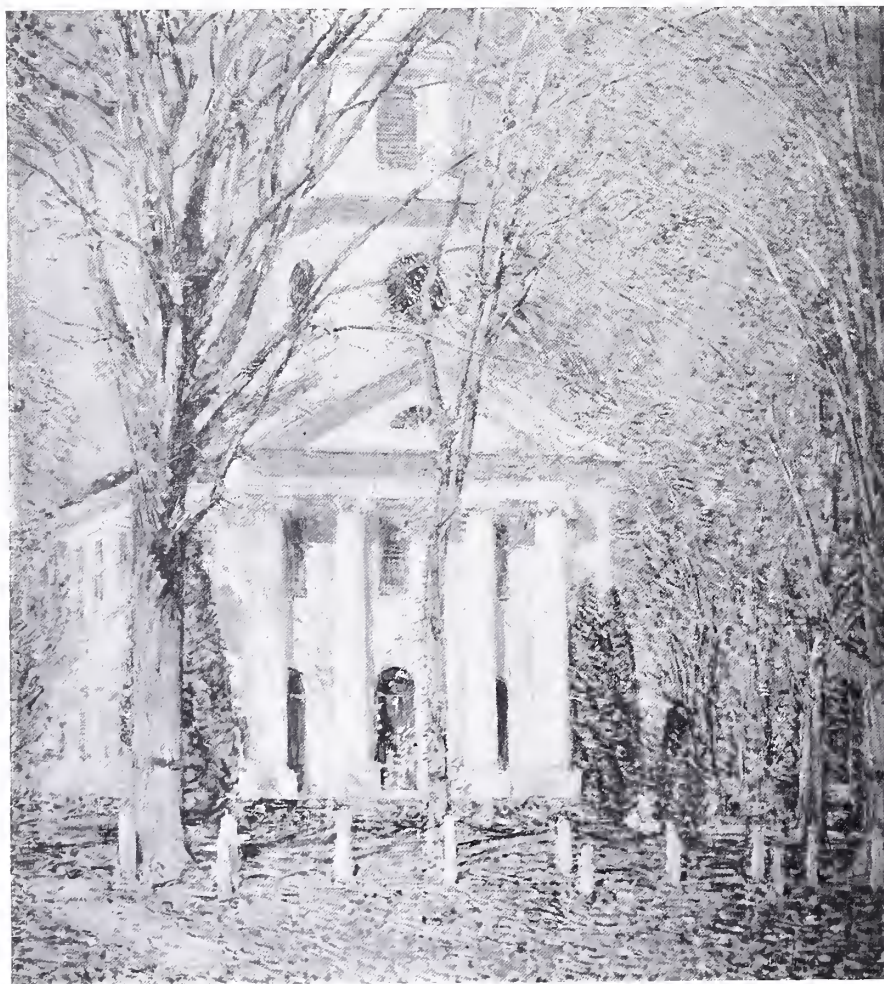

THE CHURCH AT OLD LYME

BY CHILDE HASSAM





KALMIA  
BY WILLARD L. METCALF



whole fund is not available and the question of its use is not solved. In all probability a part of the legacy will be employed almost immediately in adding to the building according to the original plan; but beyond this, if a definite policy for its administration has been formulated it has not been made known. Rarely, indeed, has a young institution had so large an opportunity with such ample equipment!

The building which now bears the name of the Worcester Art Museum and houses the summer exhibition stands back from the street on a plot of ground, more than two acres in size, utilized for parking. Its location is central (only a few blocks from the Court House before which, by the way, is Messrs. French and Potter's equestrian statue of

General Devens), and its setting is charming. In design it follows the Italian Renaissance, and in form it is rectangular. The material is granite and light colored brick with marble trimmings. In the basement, where entrance is made, are four rooms, each 25 by 42 feet in dimension, used severally for the classes, officers and library. On the first floor are two statuary halls, each measuring 42 by 52 feet, and a central staircase hall of ample proportions. These are lighted by side windows, but on the second floor, where the picture galleries are located, the light comes from the top and is so admirably regulated that every picture is seen to the utmost advantage.

These picture galleries are of the same size as the sculpture halls, but of greater height. The floors



*Permanent Collection, Worcester Art Museum*

PORTRAIT OF  
MRS. RENNY STRACHAN

BY SIR HENRY  
RAEBURN

are of hardwood, polished, and the walls are covered, above the wainscot, with brown burlap. They are peculiarly well proportioned—dignified but not severe. A feeling of informality, in fact, pervades the entire Museum. The exhibits are broken and diversified, but in no wise confusing. In the halls are set forth small collections of Chinese porcelains, Japanese prints, musical instruments, medals, antiquities from the Troad, Favre glass and the like, each complete in itself, and in every instance delightfully arranged, but offering merely, as it were, passing refreshment, continuing rather than breaking in upon the interest of the main exhibitions. Everything, indeed, in the Museum is in good taste, inviting, beguiling; the visitor is rested rather than fatigued, delighted as well as



“RELIC OF KINGS—  
WRECK OF FORGOTTEN WARS”

BY CHARLES H. DAVIS

profited. And this, according to museum lore, is the consummation of art.

Without doubt this condition is attributable to the excellent judgment and wise direction of Mr. John G. Heywood, who has been not only a member of the board of directors, but the manager of the Museum since it was first opened, and has, moreover, time and again constituted both jury and hanging committee for the summer exhibitions. Seeking the advice of leading artists in the several centers, he has year after year visited the principal exhibitions and personally selected the pictures which were later invited for the summer shows.

The purpose of these Worcester exhibitions has been to give a résumé of the output of the preceding season, but not to furnish an arena for painters of aspiration. If the painters profited by it, so much the better, but the exhibitions were primarily arranged for the benefit of the general public. This has given them a different character from the average, restricted them to a degree, and yet militated strongly toward their success. Laying aside all discussion of the comparative merit of the jury system

it must be confessed that in studying results alone the one-man process triumphs. And yet it is understood that every jury—singular or plural—is not equally endowed with critical judgment and catholic taste; that there are few indeed with sufficient grace to be able to discover merit regardless of personal prejudice.

This has been done in assembling the Worcester Art Museum's current summer exhibition. Good pictures of all types have been brought together and worthy painters of all schools have been given representation. Not great men, or great works—that is the greatest—but those of sterling worth and high attainment. Not the sensationalists but the quiet, steady workers, the men whose productions will possess permanent value; and amazing indeed will the observer find it when taking account of the absentees that the display is so entirely satisfying.

An exhibition of one hundred and sixty-four recent paintings in which each exhibit may lay legitimate claim for attention, and in which at least nine-tenths make through their merit definite appeal, is truly a phenomenon, but this undoubtedly will be



HENRY AND JACK  
BY HENRY SALEM HUBBELL

## Worcester Art Museum

found true of the present exhibition at Worcester. The cream of last winter's exhibitions is there—that which the Carnegie Art Institute failed to skim—and good indeed is it to look upon.

Three prizes were awarded by a jury of artists, but there is no "place of honor" or other specific mode of distinction. There are only two "lines" and the second is as good, in point of position, as the first, so all the exhibits are literally shown on a parity. There are in fact no "helps for the indolent" in the matter of determining merit, no hints from a committee; so if the visitor desires to be critical he must rely upon his own judgment.

According to the catalogue the exhibition begins in the west gallery wherein are hung, with the loan paintings, sixteen pictures belonging to the Museum's permanent collection, among which may be mentioned a charming, unfinished portrait of Mrs. Perez Morton, by Gilbert Stuart, a Copley, *The Fortune Teller*, a portrait of Mrs. Renny Strachan, by Sir Henry Raeburn, the *Venetian Blind*, by Edmund C. Tarbell, *The Alban Hills*, by George Inness, a cartoon for colored glass, *Suonatore*, and a little picture, *The Bather*, both by John LaFarge, and a marine, *The North Atlantic*, by Charles H. Woodbury. It is a novel idea to place the old with the new in this fashion—to combine the work of the early masters with that of the late producers—but

it is a safe experiment and a good one. The rest of the exhibition is of necessity brought into accord and neither section suffers by the comparison.

It has been said that the American painters to-day are chiefly experimentalists, that they fail to carry their works to conclusion; and in part it is true. But the strongest impression wrought by this summer exhibition is that through this experimentalism they are rising to greater heights. The pictures there are in subject and treatment widely diverse, but they are thoughtful and accomplished. A learned editor has complained that the writers of to-day are producing chiefly to please the present generation, and in part at least our painters have laid themselves open to the same impeachment, so it is especially gratifying to note in this collection tendencies toward more studied work which augurs permanence.

Turning from generalization to specific examples the observer will find much of genuine interest. *The Night*, by Charles Warren Eaton, is an extraordinary piece of painting, subtle and finished—full of light and air; and there is much to satisfy the critical in Charles H. Davis's *Relic of Kings—Wreck of Forgotten Wars*. George Glenn Newell's *Loading Salt Hay* is excellent in tone and treatment as well as in composition, and Gustave Wiegand's *Evening, Mt. Batty, Maine*, through its reticent and



THE LUMBERMEN

BY JOHN GORDON SAXTON

skilful handling commends itself. Carleton Wiggin's *Leader of the Herd* occupies a place of prominence in the west gallery, and Henry Salem Hubbell's *Henry and Jack* likewise attracts attention. Both are strong works and though they leave the medium a little too apparent possess a fresh, purposeful vigor which is not only pleasing but significant.

Gari Melchers has contributed a sketch of his wife, *The Black Scarf*, which is clever and somewhat effective but cold in color and not up to his best standard; while Henry Oliver Walker has sent his *Portrait of Mrs. H.*, to which the third prize was awarded.

Again the temperamental and visual difference of our American painters is manifested and emphasized. William Keith's California pictures, keyed to the tradition of the Barbizon School, hang near Childe Hassam's well known *Old Church at Lyme* and Albert Groll's Arizona landscapes, which savor strongly of extreme modernity. Willard Metcalf's *Milky Way* is to the right of Colin Campbell Cooper's *Bowling Green*, and with William Ritschell's *Katwijk Strand* has been placed Leonard Ochtman's *Winter Afternoon*—the one decorative, the other purely pictorial. It is impossible to single out those of most moment or to dwell at length upon any. All are of import and none is preeminent. The prize jury (composed of Messrs. Thomas Allen, Thomas Eakin and Alexander T. Van Lear) must have had a difficult task, though on the other hand whatever choice had been made could scarcely have been accounted an error.



THE FORTUNE TELLER

BY F. LUIS MORA

The pictures receiving first and second award are to be found in the east gallery and are namely, *Oxen Drinking* by Horatio Walker and *At Sea* by Charles H. Woodbury, both too well known to need description or comment. No doubt, for completeness and technical merit, they deserved the distinction.

In the east gallery are also to be seen Arthur Hoeber's *Flowing Tide*, Frederick Ballard Williams's *Gorge*, Philip Hale's *Spirit of Antique Art*, T. W. Dewing's *An Arabesque*, and Charlotte Coman's *Summer Afternoon*, each of which lends a note of individuality. Mrs. Adelaide Cole Chase's charming portrait of Miss Jacques is there, as well as the excellent likeness of Frank R. Whitside, painted by Hugh Breckenridge. Passing slowly

## Floor Covering in Summer

around the gallery one cannot fail to observe the strength of Robert Henri's *Girl in White* in spite of its unpleasant manner of presentation, the sterling worth of the Helen M. Turner's literal interpretation of a *Hut on the Rocks*, together with the subtle and intelligent handling shown in Henry Snell's *Low Tide* and J. Francis Murphy's *Hillside Farm*; or to find pleasure in Benson's *Marine with Boats*, which has been fairly drenched with color, and Willard Metcalf's clever transcription of *Kalmia*. There are two admirable decorative figure paintings, *The Princess* by William Cotton and *The Three Ages* by Hugo Ballin, and more than one good genre. And best of all, it is the younger painters who are chiefly to the front—the generation which has just begun to make its influence felt. If this is indeed a résumé of the latest period of production there is truly reason for faith in our native art and cause for congratulation. Much does it redound to the credit of the Worcester Art Museum. Perhaps it will be said that such an exhibition,

and such an art museum, are not phenomenal in this particular region; and it is true that at Pittsfield and Springfield and Northampton, to say nothing of Boston and Providence, there are other exhibits, transient and permanent, arranged for the edification of a discriminating public; but even so, is it the less remarkable? Is not, on the contrary, its present status and future growth the more notable and interesting?

Coöperating with the Worcester Art Society, the Worcester Art Museum has arranged each year a course of lectures on art which has been given in one of its galleries, and in this way, as well as through the exhibitions and the school, effort has been made to reach and assist the people. Before it stretches a broad field of usefulness the boundaries of which are still undetermined. New buildings must be erected, acquisitions made, policies formulated.

This is an era of growth and, among museums, a period of much development. The ethical value of art is being better understood, and the masses are being better educated. There is yet much to do, and for this very reason with conservatism, purpose, and power, the future of the Worcester Art Museum seems at the present time most promising.



MATTING

JAPANESE

## FLOOR COVERING IN SUMMER— MATTING

THE Goop, that wonderfully and fearfully made creature of Gillette Burgess, voiced one of our human needs in the halcyon days of that brief-lived periodical "The Lark." The Goop, as many will remember, gave utterance to this profound thought:

I wish that my room had a floor.  
I don't care so much for a door;  
But this crawling around  
Without touching the ground  
Is getting to be quite a bore.

There are people ready enough to admit the necessity of floors, who have no use for Goops. They are the collateral descendants of the gentleman who has come down to fame by virtue of his downright attitude toward the "yellow primrose by the river's brim." To them, a floor is a floor, and nothing more. But floors which do not alter when alteration is found in the seasons hardly deserve the name.

The aspect of things beneath our feet has a more important effect on one's feelings than we com-





GIRL IN WHITE  
BY ROBERT HENRI

## Floor Covering in Summer

monly suppose. Many people can come from an unfamiliar room without being able to give the slightest report of the ceiling. But few people can find their way about without casting a glance now and then at their path. If a room gives the effect which goes by the name "stuffy" it is at least an even chance that the floor has been smothered. If a room is chill and cheerless, it is quite as likely that the floor is underclad. The housekeeper in our climate of extreme temperatures acts on the principle by substituting mattings for rugs in the summer months.

The best mattings still come from Japan, where weaving in reeds and grasses has long been better done than in any other country. The import is a comparatively recent branch of our commerce, dating from 1862. Interesting developments have been made in domestic manufacture. But in mate-

rial, work and design the oriental product has not been matched. We are indebted to the courtesy of Fritz and Larue, Philadelphia, for the loan of the recent samples here reproduced. The warp of these pieces is 360, about double that of good domestic manufacture. The sample in rice straw illustrates well the handling of dyed straw. The flowers in rose tints and leaves in quiet green harmonize delightfully with the warm dull yellow cast of the background. The straws are dyed at appropriate intervals along their length before weaving. The work is done by native craftsmen, mostly in their own shops, and brought in from the country for sale to the foreign buyers. Occidental craftsmen generally consider such conditions best adapted to results of artistic worth; but this is a craft in which they have either shown slight interest or met with little success.

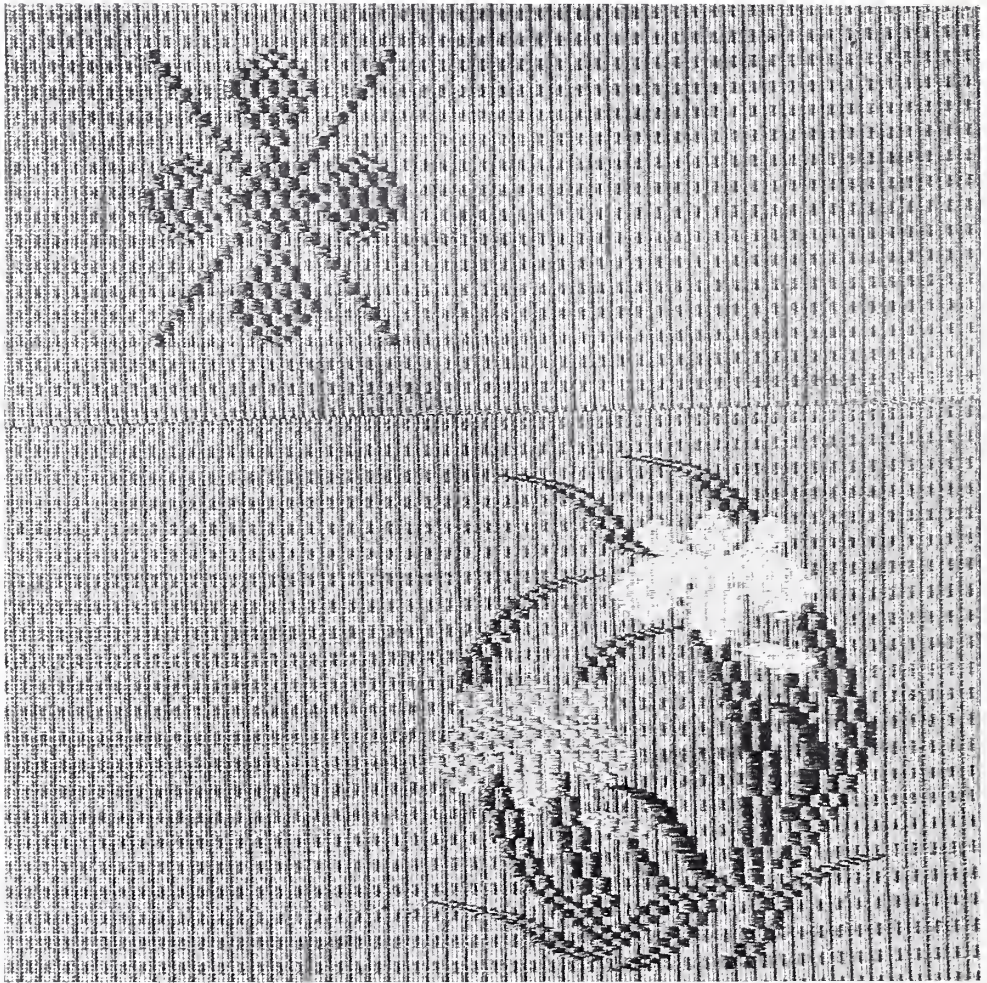

DETAIL

JAPANESE MATTING



JAPANESE  
MATTING OF  
RICE STRAW

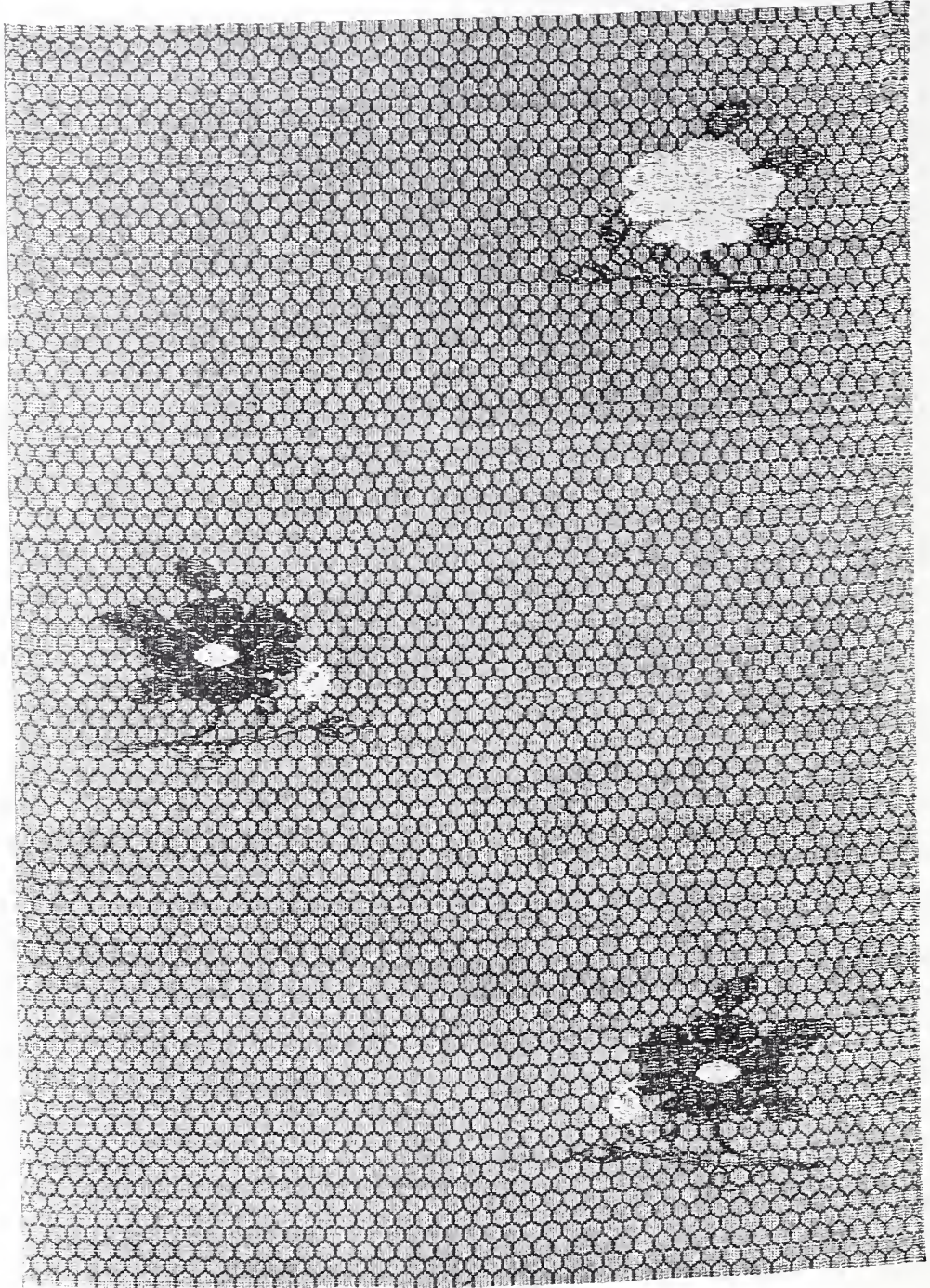

JAPANESE  
MATTING

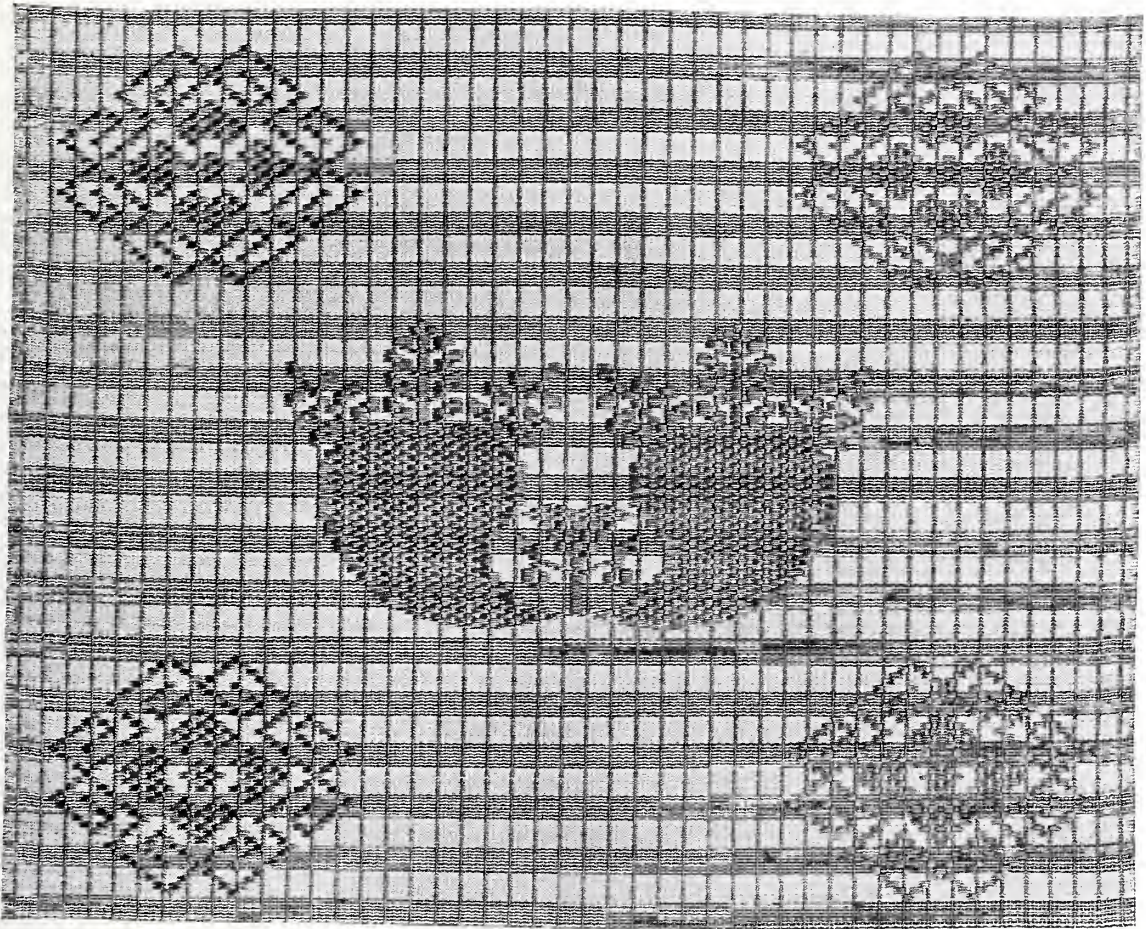

JAPANESE  
MATTING

## The California Patio



RESIDENCE OF MR. PHILLIPS  
LOS ANGELES

PATIO  
FROM WITHOUT

### TWO TYPES OF THE CALIFORNIA PATIO BY HENRIETTA KEITH

OF THE many beautiful patios in California, the court of what is known as "Gould Castle," some eight miles back in the Sierra Madre foothills from Pasadena, is perhaps the most typically Andalusian in character.

The frowning gray walls of this massive stone castle against its mountain setting might, in truth, have belonged to some mediæval castle of old Granada itself, transplanted by an Afrite's magic from their native fastnesses and dropped into this new world setting.

A superb promenade crowns the castle wall, from whence one looks forth upon the snow-capped tops of the Sierra peaks; nearer are the purpled hills,

and nearer yet gray olive orchards, the black plumes of cypress hedges and sunny gardens.

All the living and sleeping-rooms of the house give upon the inner court or patio, through irregularly placed openings on three sides, whose charm is seen in the photographs. Neither pictures nor words, however, can convey the beauty of the lace-like decorations of iron crowning these, or the still more delicate leafage and tendril of the clinging vines—against the solid gray walls. This contrast



GOULD CASTLE, PASADENA

PATIO, LOOKING WEST

## The California Patio



PHILLIPS PATIO  
LOS ANGELES

VIEW FROM INNER  
ENTRANCE

of delicate grace and massive strength is further emphasized in the heavy-barred oaken doors, with iron hinges nailed across. Wrought iron lamps swing in corners, from long, slender wrought-iron brackets.

A decidedly modernized rendering of the patio is

entrance is sheltered by a projection of open roof timbers having an adjustable awning.

THE eleventh annual exhibition of the Art Association of Richmond, Indiana, was also shown under the auspices of the Muncie Art Association.



GOULD CASTLE, PASADENA

PATIO, LOOKING WEST

## *Lace at Pratt Institute*

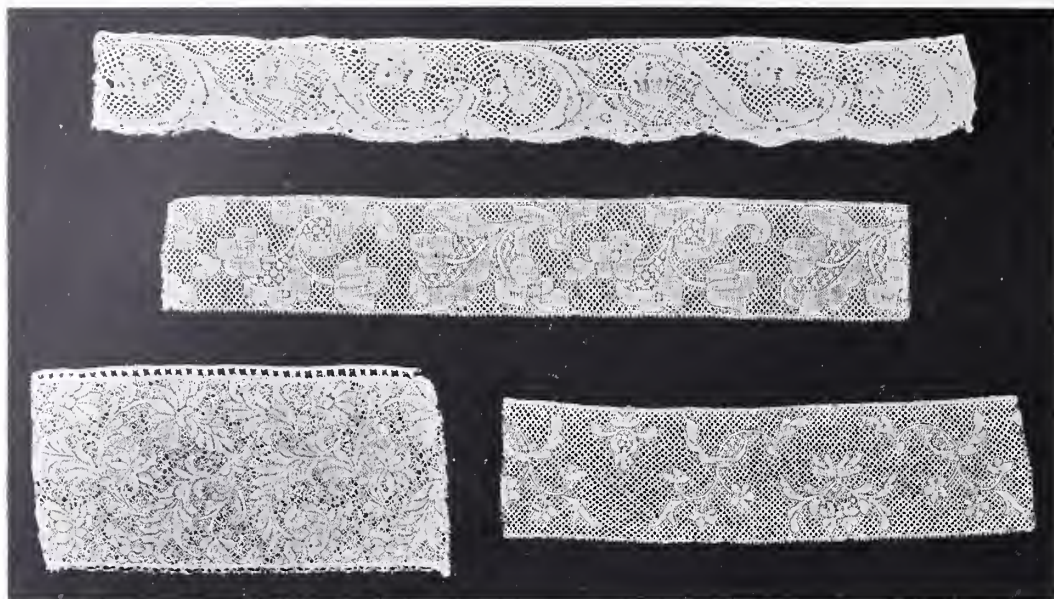

OLD VALENCIENNES LACE

PRATT INSTITUTE

### LACE AND LACE MAKING AT PRATT INSTITUTE BY EVA LOVETT

THE Lace and Embroidery Section of Pratt Institute, Brooklyn, where classes in such work are conducted, has lately acquired a collection of lace, not large, but thoroughly good and comprehensive. This collection is a valuable asset for the Institute, and furnishes an excellent object lesson for the students, which was the special purpose for which it was bought. It contains be-

tween nine hundred and one thousand pieces, including specimens of nearly every kind of lace, and covering nearly every period of its manufacture.

The majority of the lace pieces are quite small; some are only a few inches in length, but there is enough of each to show the pattern, the peculiarities of the variety, and the distinctive stitches used in making it. Each piece is complete and in good condition. Each is well mounted and labeled with the name and a short description of the kind of lace, and the place where, and the year when, it was first made and most used.

The specimens begin with early "drawn work," where the threads of the material were drawn together in clusters and patterns, leaving spaces between; "cut work," where small pieces of the material were cut out, forming a pattern, with the edges of the cut worked over with buttonhole stitch, making an effect something like the English embroidery now in vogue, and "reticella," where an elaborate pattern was worked with threads in the open spaces. All these were styles which marked the beginnings of lace making, when embroidery was developing into lace. The dates of these pieces are the fifteenth

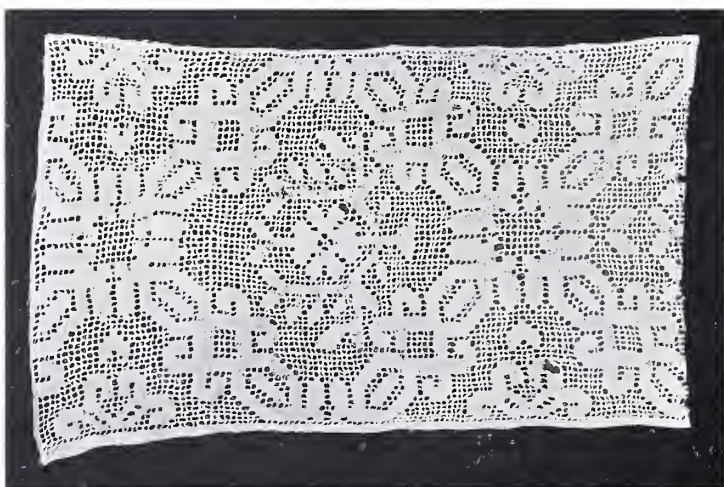

CUT WORK OF  
LACE TEXTURE

SOUTHERN ITALY



## Lace at Pratt Institute

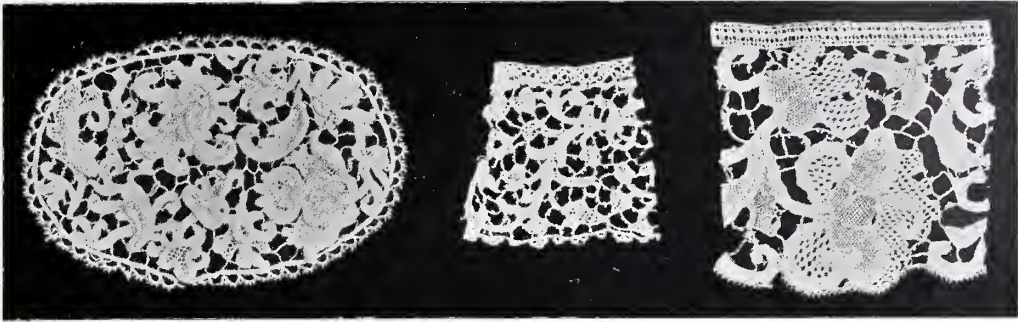

VENETIAN POINT

RAISED AND WITH BRIDE PICOTS

and sixteenth centuries. They are undoubtedly authentic, as much internal evidence proves.

Pieces next in point of age are examples of the early Venetian needle points. These were made entirely with the needle, and upon a paper on which the design was previously drawn. These show the first step in the manufacture of lace proper; that is, lace made entirely of threads without a foundation of material. In making "reticella" it was found that so much of the work could be done with threads alone, and without the material as a basis, that it was only natural that the next attempt should be the manufacture of point "d'aria," without the material at all. There are beautiful bits of these early Venice points in the Pratt collection, some of them being raised point, where the work is done over and over until a heavy effect is obtained, and some the flat point.

A quantity of examples of early valenciennes shows the really old patterns and styles of this beautiful lace, and there are many specimens of different periods and places, specimens of Brus-

sels, Honiton, Mechlin, Binches and many other German, Italian and French laces. The collection is very complete, and the pieces form a most interesting study. A few pieces have some historical interest. Several were said to belong to Marie Antoinette and to the Empress Josephine. But such statements are always doubtful, and the laces are beautiful and valuable enough in themselves to make them unnecessary.



EXAMPLE OF PRATT POINT

## Lace at Pratt Institute

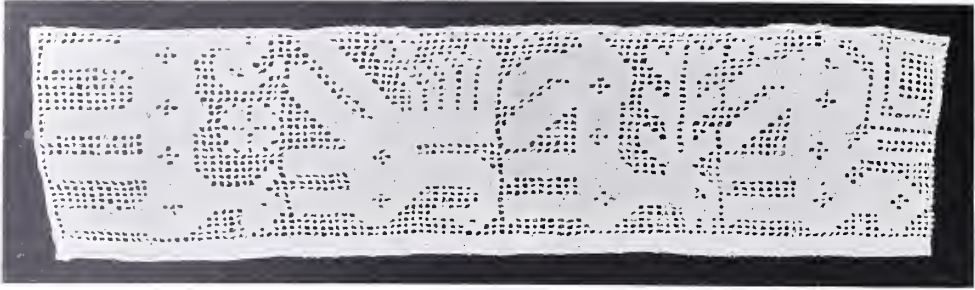

DRAWN-WORK (ABOUT 1550)

MOTIF OF ARCHAIC FIGURES

In the embroidery department of Pratt Institute they furnish a valuable lesson to students both in design and method. The early patterns were simple and effective, and nothing better has succeeded them. To have constantly before them the work of the early masters in the art of lace making cannot fail to have a distinct and elevating influence on the work of pupils in design, and to give practical lessons in detail to the learner in methods of lace making.

Original work is both encouraged and required in the Pratt embroidery and lace classes. Each article embroidered, and each lace piece made, is original, in the sense of being designed specially for the purpose. There are no duplicates, and there is no copying from a pattern. New ideas in style, method, coloring and other details of the art are required. The history of embroidery and lace, and the principles and designs used by the best makers, are first thoroughly learned by the pupil, who next studies the different kind of stitches used in the arts. Afterwards, her work is to combine these, making her own patterns from her studies of good design, and using such stitches as will best express her meaning. This method makes the

student entirely independent of patterns, and with a fund of ideas from which she can draw as she needs them. This course of study occupies about two years. The work of the department, which has been for seventeen years under a most competent director, Miss Stocking, is done on well defined lines; and certain principles of her own, the result of study and research, are justified in the competent workers sent out each year by the department.

There are also peculiarities in the method of teaching. One of these is the principle that nature subjects, to be best expressed in lace embroidery, should be conventionalized, and never literally reproduced. The thought at the bottom of such teaching is that the natural growth of flowers, leaves and blossoms cannot be adequately represented in stitchery. An attempt to make a copy of a flower in embroidery would result in a caricature. The correct way to reproduce it is to conventionalize the flower. This same idea is taught by the best jewelry workers in regard to nature forms in design.

Another principle used in Pratt lace teaching is, that the regular stitches are learned and the work executed in very coarse thread. The lace designs used in the finest kind of needlepoint, for instance, would be made in thread so coarse that the piece, when finished, would be a dozen times the size of one done in fine thread. This method is adopted for several reasons. In the first place, the novice can understand the stitches and follow the pattern better and can see more clearly the importance of exactness and care in her work, when any mistakes become at once apparent. In the second place, the coarser work is easier on the eyes and quicker. After the student has thoroughly learned the stitches and design, she can specialize in fine lace if she chooses, says the teacher. She has been taught her lesson thoroughly in a "large, round-hand," where she could perceive her own blunders.

But this heavy lace, done after the style of the

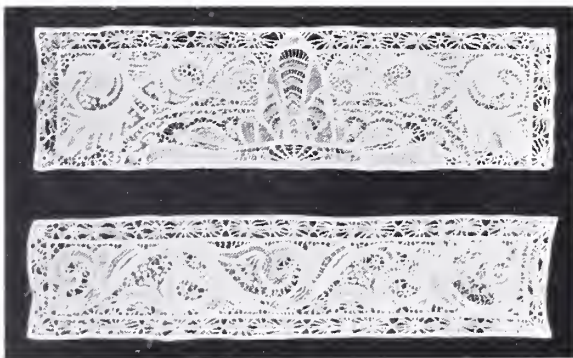

GUIPURE LACE SCREENS  
FOR DOOR PANELS

MADE AT  
PRATT SCHOOL

## The "Marie Antoinette" Shawl

old lace designs, has a charm all its own. It is used in hangings, upholstery and as trimming for gowns in bordering and inserting, for table covers and table linen. It is known as Pratt point, and is executed in heavy flax and in wool thread. A handsome set of curtains made in this lace has an elaborate design in medieval style, the lace portion surrounding the material at both top and bottom, and running up into it at the sides and at different points. A table cover of heavy linen is embroidered with a design of dolphins, seaweed and other sea motifs worked in pale colored silks. A set of curtains has leaves and blossoms in conventionalized forms worked across the bottom, with a narrower design running up the sides.

Some delicate sketchy "Kensington" embroidery is done on light tinted silks for wall hangings, and a pattern of conventionalized leaves and flower sprays is in Renaissance lace as the border of a table doily, to the linen of which it is fastened with buttonhole stitches. Some charming embroidery done on lace net suggests berries, the pieces being intended for a blouse, and sets of lace to be used as trimming for gowns are to be seen in several designs.

A striking feature of the work is its immense variety, which ranges from the heaviest embroidered draperies in silken and woolen goods to the filmiest laces of exquisite design and workmanship. An exhibition of the work done by Pratt pupils was given the latter part of June, and the finished pieces displayed, the harmonious grouping of colors, the well selected and appropriate designs, were eloquent of the value of the methods employed and the ability and diligence of the pupils.

### THE "MARIE ANTOINETTE" SHAWL

THE beautiful piece of lace herewith reproduced, of the period of Louis XIII of France, and in style guipure antique, toile d'Anglet re, point de France, has an interesting history. According to the records in the possession of Vicomte de Tardy de Montravel, the present owner, it was made at the order of Louis XV for



DOILY

EDGED WITH  
PRATT POINT LACE

Queen Marie Letzinska, by whom it was subsequently given to Queen Marie-Antoinette.

When she and her husband, Louis XVI, were taken to the prison of the Temple, which they were to leave only to ascend the scaffold, the unfortunate Queen handed the shawl to her faithful and beloved lady of honor, the Baroness de la Baulme, whose husband was then grand chamberlain of the Court. The Baroness de la Baulme went into exile during the darkest days of the Revolution. Later on she gave the garment to her daughter, who became by marriage the Marquise de Clausonette. The Marquise de Clausonette gave it to her daughter, who became by marriage the Marquise de Leautaud-Mablanc. The Marquise de Leautaud-Mablanc left it to her daughter, who by marriage became the Countess de Tardy de Montravel. The latter gave it to her nephew, the present owner. The shawl is remarkably well preserved. The shape of the shawl is triangular. The size is nine and one-half feet on the long side and six and one-half feet on the other two sides.

THE Arts and Crafts Department of the Washington (D. C.) School of Decorative, Industrial and Fine Arts will hereafter be known as "The Washington Art and Crafts Institute." It will open its second school year October 1.

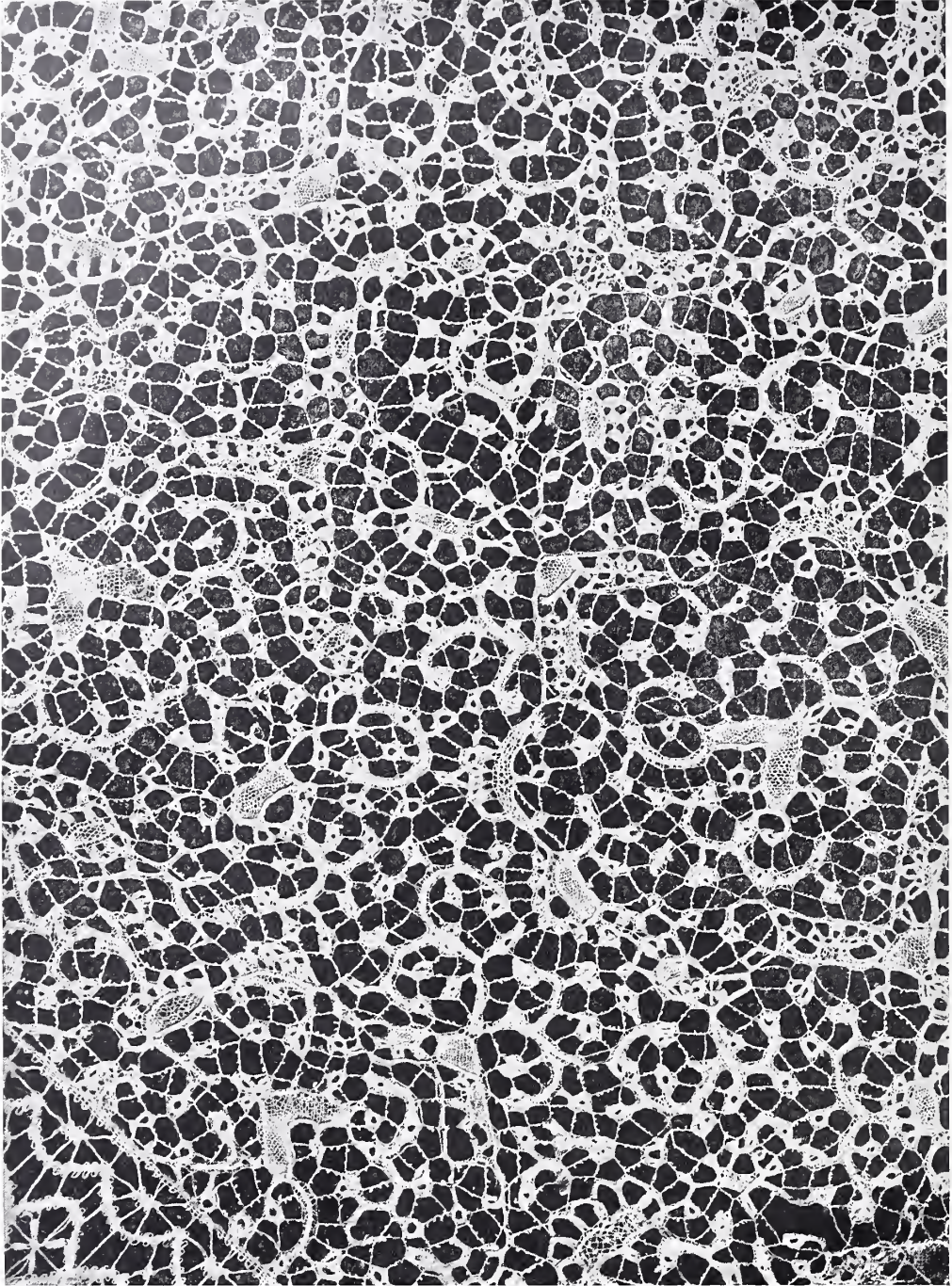

THE "MARIE ANTOINETTE"  
SHAWL  
DETAIL

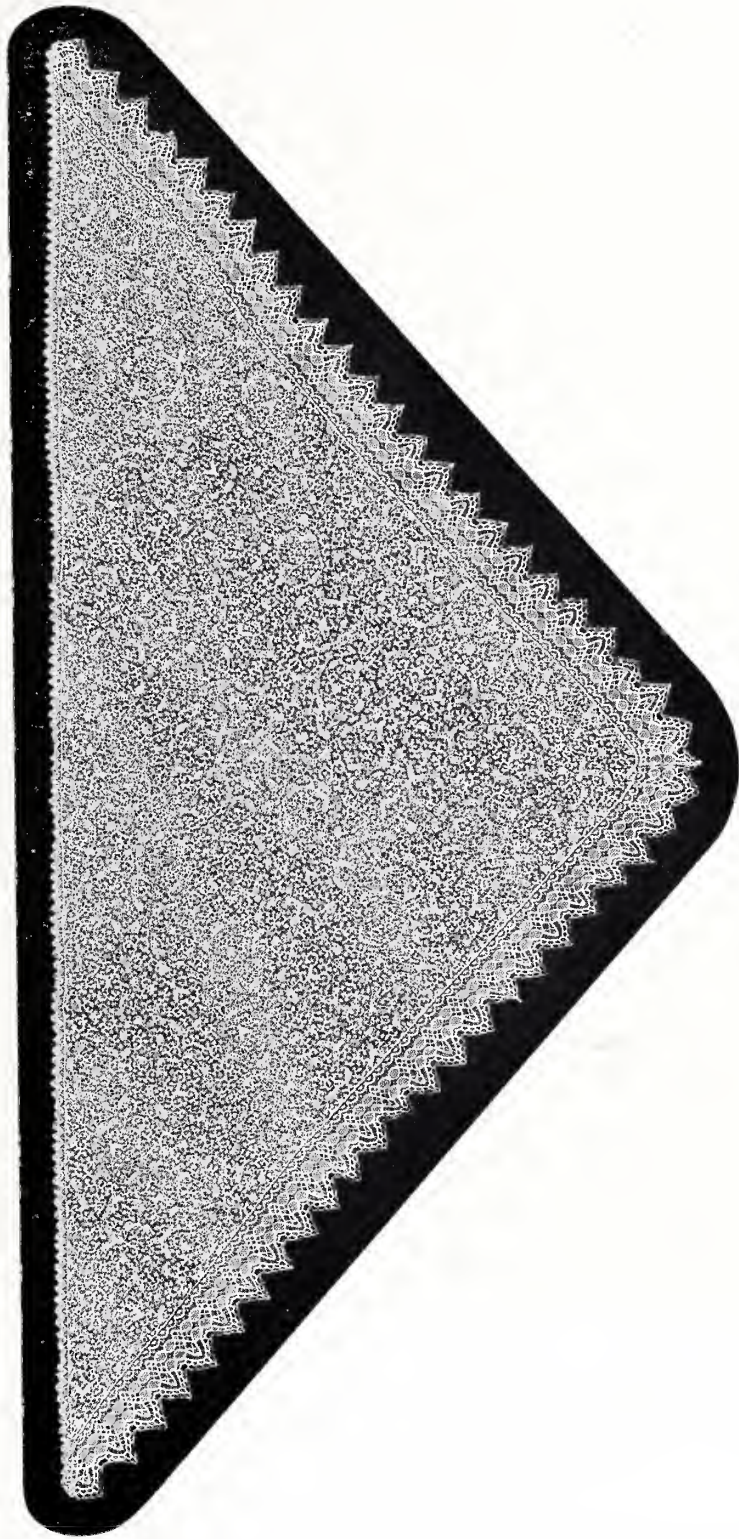

THE "MARIE ANTOINETTE"  
SHAWL

## The Garden City

### THE GARDEN CITY AND ITS UNITS

THE Garden City is a project designed to effect a working compromise between the disadvantages incident to overcrowding in our large cities and those due to isolation in the country. As a whole, the project is to some extent of academic interest in this country, but interesting applications are being made in England. And here we have become accustomed by fire, tidal wave, flood and earthquake to face the problem of rebuilding on such extended scale that we have worked along the lines of such improvements as the characteristic ideal city strives to embody. In its details, too, the problem is one that every town today, outside the Orient perhaps, does in a measure face. Ebenezer Howard's book has now been succeeded by a two-volume discussion by the civil engineer, A. R. Sennett. His book, "Garden Cities in Theory and Practice" (Bemrose and Sons, Limited), is altogether too long. In his anxiety to cover the subject thoroughly he has failed to condense sufficiently, and the reader is consequently irritated here and there by long disquisitions on matters too irrelevant for the attention bestowed upon them, such as the long, dreary disclaimer with which the author opens against any socialistic bias of opinion. But despite this the book is decidedly interesting and well worth reading.

Howard's circular plan for a city Mr. Sennett easily disposes of. He not only does it easily, but he demolishes it on historical grounds, going back to the Piræus, which, he thinks, was first wheel-shaped and later altered to its rectilinear form, and drawing the lesson of human experience. He is able



ONE WARD

HOWARD'S PLAN

to find disadvantages in the radial avenue without the circular, as in L'Enfant's plan for Washington, for which, however, the garden city enthusiasts are happy to show the greatest respect. The plans of Sir Christopher Wren and Sir John Evelyn for the rebuilding of London after the great fire show how nearly accident came to bestowing a decent street plan on the metropolis. The citizens preferred their old foundations. Wren's plan was characterized by long axial avenues, Evelyn's by recurrent park centers, and either would have been an inestimable boon to-day.

A suggestion of much interest is Mr. Sennett's inversion of the cross section of city streets. He would displace the central crown by a medial gutter, sloping the pavement down from both curbs, which would be hollow and piped for flushing. The street cleaning would be done by water helped by the rotary brush by night, and the refuse carried down under the street and removed from chambers in the service subway.

In the laying out of his plan Mr. Sennett strikes a compromise between the peculiarities incident to Howard's circular plan and Buckingham's rectilinear one. Indeed, compromise is one of the bases of his philosophy. In his revolt from the customary rectangular conformation he presents a most suggestive scheme for plotting land. This

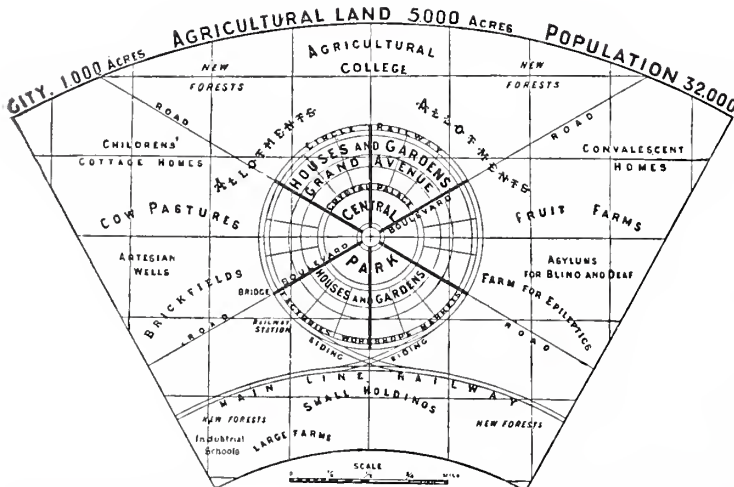

THE GARDEN CITY

EBENEZER HOWARD'S PLAN

## The Garden City

is founded on the cellular method of building pursued by the bee, and involves the use of the polygon, six or eight sided, as the unit, resulting in an interesting enlacement of allotments and saving of waste space by avoiding acute angles. The proportion of open space is thereby affected. The author sets the density of population at 25, as compared to Buckingham at 55 and Howard at 80. His road area, on the other hand, is, compared to residential, as 2 to 5, Buckingham's being as 2 to 3 and Howard's, 1 to 1.

The housing problem, the construction and arrangement of buildings, is discussed acutely for village, city, public and industrial structures. The various villages in which Garden City principles have been used, such as Adelaide, Bourneville and Port Sunlight in England, Serrières in Switzerland, and the Cleveland Cliffs Iron Company and Pullman City in the United States, are reviewed. Locomotion and traffic, the disposal of sewage and the multifarious economic aspects round out a book the defects of which are involved in an enthusiasm for thoroughness. This in itself is a pity, for the subject is one of wide appeal and high

importance. But Mr. Sennett, it is to be feared, will not be widely read until he, or some successor, has learned to make one page do for four.

J. C. N. Forestier (Inspecteur des Eaux et Forêts, Conservateur des Promenades de Paris), with the Gallic sense of organization and administrative action, sets forth a programme for the undertaking of parking systems by groups of municipalities or departments or other administrative entities. His modest pamphlet, "Grandes Villes et Systèmes de Parcs" (Hachette et Cie.), is an earnest of possible future legislation. In his succinct and comprehensive survey he discusses and maps the parking situation in European cities, and in Washington, Boston, New York, Chicago, Baltimore, Harrisburg, etc.

Two recent publications devoted to the units of garden housing, the one a collection of plans for modern country cottages, the other embracing in detail features of interior decoration, are J. H. Elder Duncan's "Country Cottages and Week End Homes" and "The 1907 Year Book of Decorative Art" (John Lane Company), the latter comprising 405 illustrations and 19 color plates.



"Country Cottages"

ALTERATIONS AND ADDITIONS TO  
"BEECH WOOD," COOKHAM DEAN

R. A. BRIGGS, F.R.I.B.A.,  
ARCHITECT

## Possibilities of Clay

### THE POSSIBILITIES OF CLAY BY CHARLES F. BINNS

POTTERY as a craft is in the public eye at the moment. Many are seeking to solve its mysteries, and some will succeed. Let none undertake the work, however, who is not prepared for patient experiment and devoted toil. In this the craft of the potter differs from others. True, in all of them skill is demanded, but the potter must be not only an artist and something of a mechanic, but a chemist as well. There is no need to be scared at this idea, for the greater the difficulty the more pronounced the success. It will not be attempted, moreover, in this paper, to plunge deep into the mysteries of science.

The first requirement is clay, and so abundant is this that every creek and spring, almost every dooryard will furnish it. Common clay is generally of either a slaty blue or a yellow color. It will burn to a brick red, but is rarely of this color when found. A good clay may be known by the smooth, unctuous feel and by the tenacity with which it holds together. In dry weather it becomes very hard, and the surface can be polished with the finger. When wet it is slippery and cuts like new

cheese. The embryo potter should search for a bed of clay, and, when found, should secure a goodly supply, to be stored under cover. For large, rough work the clay can be used, if moist enough, as found; but clay always contains sticks, stones, roots and leaves, with, oftentimes, fine sand, so that a method of purifying it must be found.

The necessary appliances for this are: (1) an oil barrel which has been burned out or otherwise well cleansed; (2) a couple of large tin buckets or pails; (3) a garden sieve of about a quarter-inch mesh; (4) a wire cook-sieve of about one-twelfth inch mesh.

The barrel should have one head removed and is to be used standing on end. Near the bottom a faucet is inserted, and this should be of the kind known as a "molasses gate," which can be procured at any hardware store.

The method of procedure is as follows: The clay is thoroughly dried and is then spread out on a clean floor and broken small. As the breaking proceeds the heap is gathered, from time to time, and sifted through the large sieve onto a spare spot. This removes the sticks and larger stones. A good quantity of the clay should be thus sifted. It will keep indefinitely. One of the buckets is now half-

filled with clean water, and the dry clay is taken up either with the hands or a common flour scoop and sprinkled over the water until the bucket is nearly full. After the lapse of half an hour the bare arm is thrust into the fluid mass and a vigorous stirring is given. This breaks up the lumps, sets free the small stones and allows the clay to be cleansed.

If much sand be found a system of washing must be adopted. The clay and water are well stirred and allowed to settle three minutes by the watch. The liquid is then poured into the second bucket, and a quantity of sand will be left behind; this is thrown away and the operation is repeated.



CLAY WORKING

BUILDING THE FORM



## Possibilities of Clay



CLAY WORKING

FINISHING THE TOP

If more sand needs to be removed the settling may be for five minutes; but it must be borne in mind that it is not wise to separate all the sand from the clay. A clay which has no sand in it is liable to crack on drying, but as no two clays behave alike experience is the best guide. The washed clay, now in the slip or liquid state, is poured through the small sieve into the barrel, and so on until the barrel is nearly full.

This wetting down of the clay is performed simply for the purpose of purifying it. A clay in the plastic state cannot be freed from stones, sticks and sand. The slip in the barrel is, however, only in an intermediate stage; it must now be thickened so that it can be shaped. After standing for a day some inches of clear water will be found at the top of the barrel. This must be drawn off either by a siphon or by boring a hole in the barrel at the proper height, the hole being afterward stopped with a peg. The thickened slip is now stirred with a wooden paddle to insure a perfect mix.

Two methods of drying out are possible. Simple evaporation will do it, but a long time must be allowed. If some of the slip be run off into shallow tubs, it will become in a few days thick enough to be

beaten in the hands, but there is a quicker plan. No pottery maker can get along well without the use of plaster of Paris, and some knowledge of the working of this should be acquired.

Plaster may be procured in small quantities at a drug store, but the better plan is to purchase a barrel of pottery plaster from the dealer. The plaster is a dry powder, and it is blended with water in about the proportion of five pounds of plaster to two quarts of water. A little less water will make the resulting plaster harder when set. A clean vessel, jug or bowl, is used for the water, and the plaster is carefully stirred in. After allowing a few moments for the plaster to soak, the hand is plunged into the mixture and a good stirring is given, so that all lumps may be dissolved. After stirring for about four minutes, more or less, the liquid will be felt to thicken, and this must be allowed to go on as long as it does not become too stiff to pour freely. The right moment is easily ascertained after one or two trials, and when it arrives the mixture is poured wherever it may be required. The receptacle in which the mixture was made must be washed clean or it will be found that hard fragments of plaster will mar the next mix.

Plaster discs, called bats, are always in demand.

## Possibilities of Clay



CLAY WORKING

INCISING THE DECORATION

They can be soaked in water and will serve to keep the clay in a moist condition. But the use of the plaster now in question is to help dry out the slip. Plaster, when dry, is very absorbent. Its use will save a great deal of time in preparing the clay. A shallow box with plaster spread two inches thick over the bottom forms an excellent trough to receive the slip. It must not be used until the plaster is perfectly dry, but when that time comes the slip may be poured in and absorption will at once begin. If the sides of the box are also lined with plaster so much the better.

To make bats a common skillet or spider is used. This is slightly oiled inside, and set on a level surface. A mixing of plaster is then made and, when quite thick, is poured into the skillet to the depth of about one inch. When quite hard the skillet is turned over, the edge rapped smartly against a brick or stone and the bat is detached. A very slight acquaintance with this material will suggest a number of ways in which it will be found useful. To mention but one other. A stout table should be procured or made, a little higher than an ordinary kitchen table, and with a top measuring about two feet by three. The edge of this table is to be raised three or four inches, and the shallow tray thus

formed filled with plaster which, by the way, should be mixed hard, say, three pounds to the quart. When the plaster top is set it forms an admirable block upon which to knead and prepare the clay. For soft clay it can be used dry and for stiff clay it can be moistened.

The clay having been brought to a plastic condition is now ready for use. It should be moist enough to yield easily to pressure but dry enough not to soil the hands. Two methods of shaping are available, the wheel and building. In factories molds are always used, but these will not be considered here. Nor, indeed, is it possible within the limits of this article to give instructions on wheel work. The wheel is the ideal method of pottery making, but the instruction must be practical. Written directions could never be complete.

Building is par excellence the method of the studio. A long training is unnecessary; it is closely allied to modeling, with which most artists are more or less familiar, and the results are unique. The plastic surface of built pottery is inimitable. The color values of the glazes and the quality of texture are greatly enhanced thereby, and the possibilities of individual expression are limited only by the material.

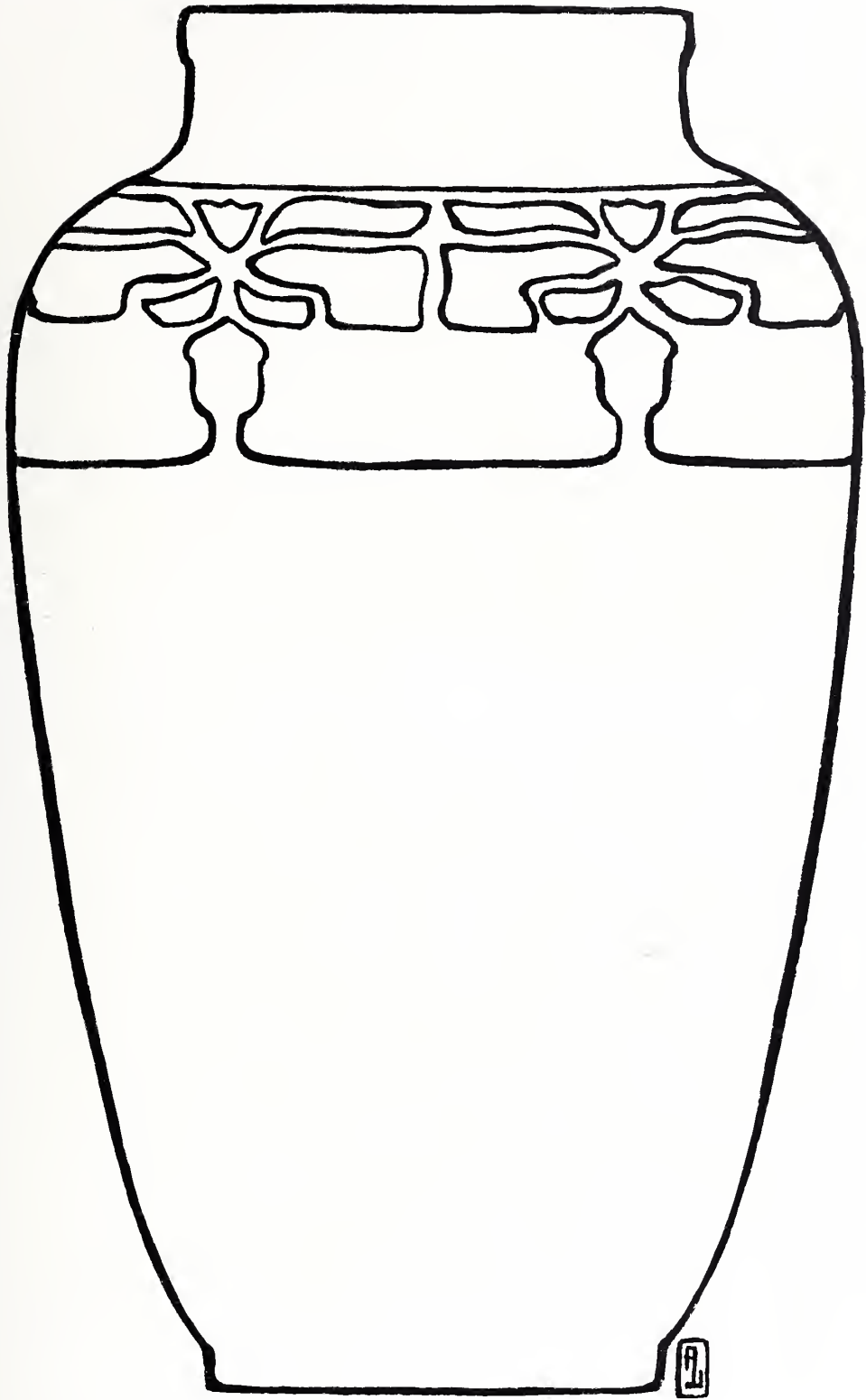

THE DESIGN

## Possibilities of Clay



FINISHED VASE

MATT GLAZE

The first point to be considered is the form, and for this a design must be carefully made exact to size. The beginner will at once be confronted by the difficulty of making the clay obey. The piece in formation will develop any and every shape but the one intended, with the probable result that the idea of the artist will undergo many changes. This is fatal to success and the first efforts must be directed toward following a pre-conceived and established line. The drawing should be simple in form and the work should be persevered in until the object fulfils its purpose. This is not copying. It is simply training the fingers to obey the brain. When one can follow a given line with ease, the drawing, which is but an intermediate step, may be dispensed with.

There are two general methods of building, one by coils, the other by pieces. The former is the method used by the Indians, from whom the idea has been derived; the latter has been adopted by some modellers who were already familiar with clay. The coil only will be dealt with here. The clay having been brought to the workable condition already described, and the design being decided upon, a plaster bat large enough for the base of the proposed piece is soaked in water and all is ready.

Some of the clay is rolled out on a clean table (an oilcloth cover is a good thing to work upon), making a long uniform cord. This is now coiled in a spiral on the bat, beginning at the center. When the diameter of the proposed jar has been reached, the coils are gently rubbed together so as to produce a smooth surface. The clay is to be kept firm and stiff, as little water as possible being used. Probably the coils will need to be slightly moistened or they will not stick together, but practice will soon show the proper condition. Upon the circular base the walls are now begun in the same spiral fashion, one coil after another being rolled out when needed. If the clay be inclined to break off short on being rolled it must be used a little softer or, if the trouble becomes serious, a remedy must be sought in a reduction of the amount of sand in the clay. This is accomplished by washing as already described.

When the walls have been raised about an inch a measurement is taken and, this being correct, the work should be laid aside to stiffen. If the attempt be made to continue building on the soft walls the sides will inevitably sag. For this reason it is profitable to have two or three pieces in hand at once, as one can be hardening while another is progressing. And so, stage by stage, the work is carried on. Frequent measurements and comparisons with the design will keep the piece true and the result will be as was originally intended.

If there be any considerable difficulty in following the line a plaster template may be cut. The drawing being, of course, full size, is laid upon a sheet of plaster and the outline is traced through the paper with a hard point. The plaster should be moistened in water to make it soft. With a pocket-knife the line can be cut out, thus giving the shape of the work in the plaster. This shape applied to the clay from time to time will keep the line true.

It is a great advantage in all clay work to have a turntable, commonly called a whirler. Table whirlers are made by the potters' machine men, or a banding wheel as used by decorators will serve. This enables the work to be turned from side to side with ease and, after a trial or two, no potter would be without one.

As the clay becomes partially hard in successive stages the interstices between the coils must be filled. A small sponge is used to moisten the coils and soft clay is pressed firmly into every open space. The surface is thus made uniform and smooth and may be finished to suit the fancy of the artist. If the clay be used too soft it is likely to crack between the coils, but this can be easily

## *Possibilities of Clay*

remedied by a second application of clay followed by a sponging and scraping. In finishing wares of this type it should always be borne in mind that the plastic quality is to be retained. There is no need that the coils should be visible, but there should be no attempt at a perfectly true surface. This work affords a wide scope for individuality: one will prefer a broad treatment while another works for a high finish. In connection with this it is important to notice that form, size and texture should be in agreement.

Some arrangement should be made for keeping the work moist. Damp cloths are very unsatisfactory. One of the simplest plans is to use a jar such as those sold for pickling meat. Such a jar, with a close-fitting cover, will prove very satisfactory if a little water be allowed to stand in the bottom and a support provided to keep the work clear of the wet. For small work a plaster bat may be made quite wet and a jar inverted over it like a bell glass.

In the decoration of clay wares there are three possible treatments: the clay may be either incised, inlaid or embossed.

In either case the condition of the clay and the kind of tool used is of importance. For incising the clay must be "leather hard"—just so hard that the tool will cut freely and leave no burr. If a simple line be desired a blunt point of metal or

hardwood is all that is necessary. If a broad incised surface be intended, a steel modeling tool must be used. One should be selected with a broad, square edge set at right angles to the stem of the tool. This can be used as a chisel and the clay is cut out in the desired form.

For inlaying, the piece should be a little softer, for the clay inlay must be soft and there should not be too great a discrepancy between them. The design is cut out exactly as in incising and the trench is then filled with clay of a different color. Some experimenting will be necessary here, for no two clays are apt to shrink exactly alike. It is supposed that a red burning clay is being used. If now it be desired to use a dark brown inlay, some black oxide of manganese may be added to the red clay. The result of this will probably be that the brown clay will shrink more than the red, crackling away along the lines of the ornament. In such case a further admixture must be made such as this:

Red clay.....	74
Manganese oxide.....	6
Kaolin.....	10
Ground flint.....	10
	100

The kaolin and flint will counteract the influence of the manganese, except as to color, and thus the shrinkage of the red clay will remain unchanged. This mixture is made up into a stiff paste and



THE FINISHED PRODUCT

BUILT POTTERY

## Possibilities of Clay



FINISHED PRODUCT

BUILT POTTERY

pressed firmly into the incised hollows. When somewhat hard the surface is smoothed off and the whole may be polished with a steel or ivory tool.

Embossing may be done either with clay or with slip. The former simply consists in modeling a raised decoration on the plain form; the latter is the laying on of a raised decoration by means of a brush. The clay piece must be softer than in either of the former cases and the slip must be laid on in their coats, one over the other. This work is capable of very fine manipulation, but demands both skill and patience.

Except for garden pots, pottery is not considered complete until glazed. A simple brilliant glaze for a red clay may be made from the following mix:

White lead.....	46 parts by weight
Whiting.....	10 "
Red clay.....	5 "
Ground feldspar.....	27 "
Ground flint.....	12 "
	<hr/> 100

The ingredients are weighed out and put into a good-sized mortar; enough water is added to produce a thin paste and the whole is thoroughly mixed. More water is added and the mass is poured through a fine sieve—one of eighty meshes to the inch is not too fine. The glaze is then allowed to stand, the clear water is poured off and the mix is ready for use.

The pottery, having been already burned for the first time, is soaked in water and wiped dry. The glaze is then either poured or painted over the pieces, which are well shaken to secure an even coating. A second drying is necessary and the wares are ready for the final burn.

The vase used for illustration was designed and built by Miss Alice L. Upton, instructor in art in the New York State School of Clay Working, at Alfred, N. Y.

THE Art Association of Dallas, Texas, has recently acquired by purchase the two paintings, *The Water Carriers of the Ganges*, by Edwin Lord Weeks, secured by ex-President Clifton Church, at a recent sale in Boston, and *The Driving of the Herd*, by Frank Reaugh, thoroughly Texan in subject. At the last exhibition of the Western Society of Artists, of which Mr. Reaugh is a member, this picture was particularly commented upon for its splendid rendering of West Texas atmosphere, its bigness of conception and excellent workmanship. Mr. Reaugh is a Dallas man. Organized in 1903, the Dallas Art Association has annually added to its collection of pictures. At the present time it has hanging in its gallery paintings by Walter McEwen, *The Kiteflyers*; by Childe Hassam, *Moonrise at Sunset*; an Irish coast scene, by W. T. Richards; *The Venetian Kitchen*, by F. W. Faulkner; a flower composition by R. J. Onderdonk, a Texas painter residing at San Antonio, and examples from the brushes of Julian Onderdonk, Westerbeek, Gedney Bunce, Gustav Wolff and others, including a charming bas-relief by Miss Clyde Chandler, a native of Dallas.

The fall show is scheduled for November. The officers of the present year are Mrs. A. D. Lane, president; A. G. Elliott, vice-president; Mrs. E. J. Kiest, treasurer; Mrs. J. E. Cocknell, secretary; E. G. Eisenlehr, corresponding secretary.





"SUNSHINE AND WIND." BY CHARLES SIMS.  
*(by permission of the Hon. John Collier.)*



*Charles Sims*

**T**HE PAINTINGS OF MR.  
CHARLES SIMS. BY A. LYS  
BALDRY.

OF all the faculties which are necessary for the complete equipment of an artist who desires to break away from the ordinary conventions, none is more important than the imaginative capacity. The power to imagine is not given to many people, and it is not one which can be acquired by any educational process; it is innate, in the sense that it is a purely temperamental characteristic, and a part of that general mental endowment by which a man is enabled to make his individuality effective. The artist who possesses it is, under proper conditions, capable of really memorable achievement, because he thinks for himself, and does not depend upon others for that small measure of inspiration which is to be acquired at second hand. He chooses his own direction and follows it logically and consistently, understanding well enough where it will lead him ultimately, and knowing how he intends to profit by the opportunities which come to him.

If the imaginative man desires to make the fullest possible use of his natural faculty and to turn it to the best account in artistic practice, it is necessary for him to cultivate his powers both of observation and expression. Shrewdness of observation is indispensable to him, because it is the foundation upon which all imaginative effort is based. Indeed, imagination is actually a consequence of that constant study of realities which is carried on consciously or unconsciously by every original art worker, and it depends for its freshness and individuality upon an intimate acquaintance with the facts of nature. No man can imagine anything which is completely non-existent, or for which there is no warrant in nature; the most he can do is to invent new combinations of the details he has collected, or to give by a touch of fantasy an unaccustomed aspect to familiar things. But the degree of success he attains is due directly to the amount and character of his observation, to the extent of his enquiry into the more subtle possibilities of the motives which offer themselves to him for pictorial treatment. If his view



“PLAYMATES”

## Charles Sims

is superficial and his investigation unintelligent, his work will be lifeless and without conviction; but from a broad and thoughtful outlook comes a confidence in production that will impress the artist's individuality upon everyone who is capable of analysing his methods.

In the same way, if he has not a thorough command over those technical processes by which he puts his imaginings into a visible, pictorial form, the message he desires to convey will be ineffectual and unpersuasive. Fluent and expressive draughtsmanship, decisive brushwork, and sensitive management of colour and tone, are of the greatest importance to the painter of fancies, because without these executive essentials, his pictures will have no authority as serious works of art. His ideas, haltingly set down, will seem artificial and unreal, merely fantastic departures from sobriety, and his work will create the wrong impression that he has broken away from accepted conventions in a simple spirit of perversity, and with a misconception of his own powers. If he is not a sound craftsman, his

imagination will not serve him, and his shrewdness of observation will lead to nothing; he will rank, at best, as nothing more than a possibility—as a man who might have done great things if he had been able to give effect to his intentions.

It is as an artist who possesses in unusually right proportion all the qualities needed by the painter of imaginative pictures that Mr. Charles Sims has to be considered. Imagination he certainly has—a freshness and unconventionality of fancy which can be welcomed as singularly attractive—and he has developed both his powers of observation and his command over processes of painting in an uncommon degree. He attacks, and overcomes, problems which are peculiarly difficult to solve; and he succeeds, not because he has discovered a convenient formula which assists him to evade what is perplexing, but rather by using all his resources to enable him to arrive at the end he desires. Few present-day painters equal him in acuteness of observation, fewer still surpass him in mechanical skill; his equipment is



“THE NEST”

BY CHARLES SIMS

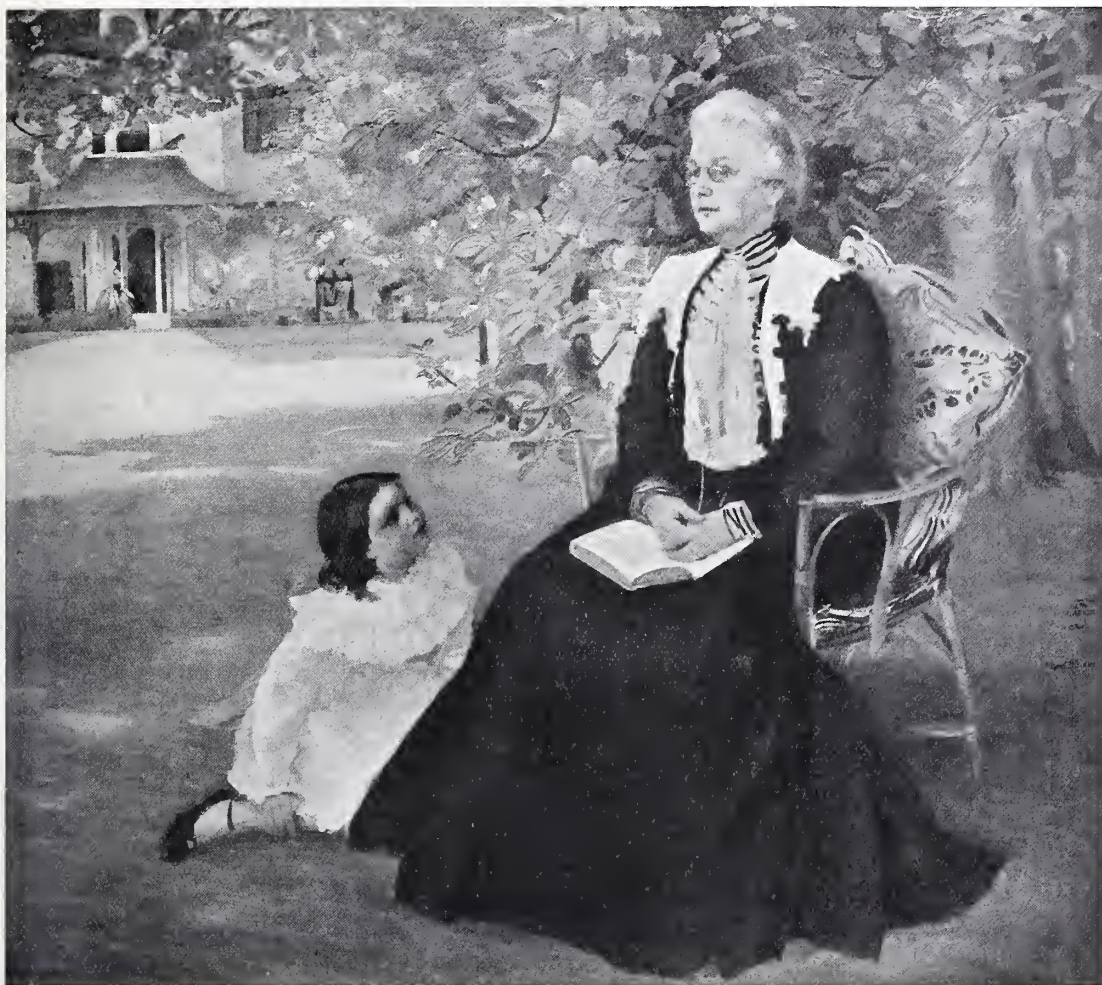

PORTRAITS

BY CHARLES SIMS

exceptionally complete, and he lacks nothing which lovers of serious achievement would regard as vitally important.

Perhaps his best mental characteristic is his readiness to interest himself in very dissimilar motives, and to choose subjects which differ from one another in a marked degree. His fancy does not run in a groove; it is bounded by no set conventions, and has, as yet, no defined limitations. In a sense, indeed, Mr. Sims is decidedly an erratic artist, for he ranges about from one type of picture to another, and takes, apparently, a pleasure in unexpectedly breaking new ground. This unwillingness to settle down to any one line of practice—an unwillingness, by the way, which is among modern artists as rare as it is commendable—is doubtless due in some measure to the restlessness of youth; he was born in 1873, so that he is even now too young to have lost his love of experiment.

But it comes also from his instinctive originality, from his innate conviction that repetition means loss of opportunity; the desire to roam in whatever direction he pleases is natural to him, and to abandon it would mean that he would have to sacrifice something that he values greatly.

His habit of experiment, however, is not the mere careless drifting of the man who does not know his own mind; and it is certainly not the result of any doubt concerning the vital essentials of art. It is really an evidence of his desire to test in as many ways as possible the thoroughness of his observation and the general applicability of his executive methods. When he has satisfied himself on these points, it is possible that he may decide to work within particular boundaries, or to deal only with one kind of material; limitations of this sort may, indeed, be imposed upon him, whether he wishes it or not, by the popular demand,



“CHILDHOOD.” BY  
CHARLES SIMS



"BUTTERFLIES"  
BY CHARLES SIMS



"WATER BABIES"

BY CHARLES SIMS

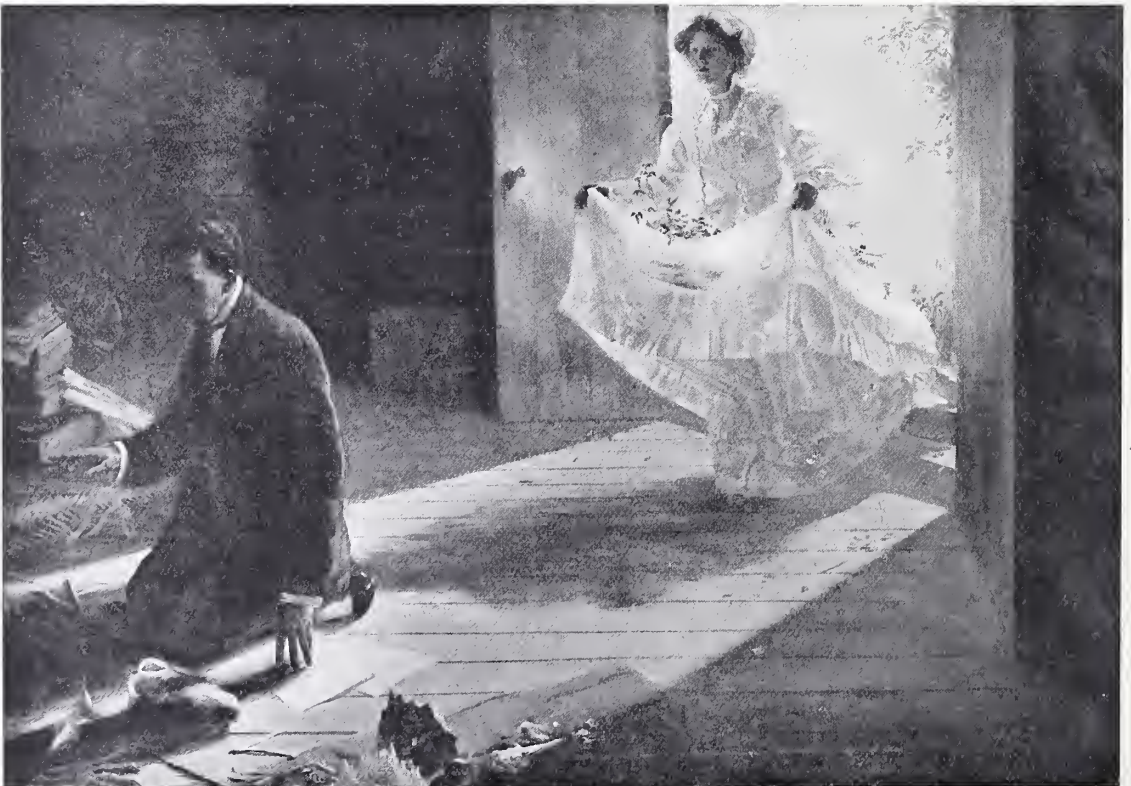

"LOVE AND A STUDENT"

BY CHARLES SIMS

## Charles Sims

but no one who has watched his progress during the eleven years which have elapsed since he made his first appearance as an exhibiting artist could desire to see him hedged round by any unnecessary restrictions.

For, from 1896, when he dramatically asserted his powers with *The Vine* and his *Portrait of Miss Sims*, to the present year, when he has just put the seal upon his reputation by his amazingly accomplished picture, *An Island Festival*, his variety and unexpectedness have been the delight of all art lovers who possess real breadth of mind. Now and again he has shown a preference for one kind of

subject matter, and has played for a while with motives closely akin—as in his *Washerwomen* series; his sea-side pictures, of which the *Playmates* and *Water Babies* can be taken as types; or his studies of breezy uplands like *Butterflies*, *The Kite*, *The Top of the Hill*, and *Sunshine and Wind*. But to none of these has he adhered for any length of time; he has always broken away into something new, or into something which showed a fresh development of the idea that had been previously in his mind.

In fact, a list of his more important canvases shows very plainly how far he has been, and still is, from fixity of conviction. His extraordinary fantasy, *The Vine*, was followed in 1897 by that exquisitely tender piece of imagination, *Childhood*; his *Fairy Wooing* and the *The Kingdom of Heaven* came in 1898 and 1899; and in 1900 appeared *In Elysium*, a wonderfully able attempt to deal with the most difficult problem that a painter can face, the painting of the nude in the open air. Then from 1901 to 1905 he exhibited *Spreading their Wings*, *The Top of the Hill*, *Water Babies*, *Butterflies*, *The Kite*, and *The Nest*, all of them out-of-door studies full of sunlight and breezy atmosphere; and to the same period belong the three or four pictures of the *Washerwomen* series. In 1896 he had at the Academy his *Land of Nod*, a fantasy pure and simple, and this year there is the *Island Festival*, extraordinary both in its imagination and in its grasp of the higher principles of naturalism.

The wisdom of this frequent change is undeniable: it has given him valuable experience, and has provided him with a foundation upon which he can build up almost any kind of pictorial art. He has recorded plain actualities with certainty and directness; he has painted effects of open-air lighting and aerial tone with extraordinary sensitiveness; and he has given free rein to his fancy in a number of compositions which, by their nature, could not well be treated as mere matters of fact. In them all he has noted intelligently just what is most appropriate to each subject, and by the exercise of right judgment has seized upon and realised



PORTRAIT OF MR. GERALD LAWRENCE

BY CHARLES SIMS



"THE ISLAND FESTIVAL"  
BY CHARLES SIMS

(Royal Academy, 1907. Copyright reserved)





"THE VINE"

BY CHARLES SIMS

whatever he felt to be necessary for explaining the character and significance of the incident depicted. Through the whole of the work he has so far produced the dominance of his temperament can be clearly perceived; but in asserting this temperament he has not, as painters with a strong personality often do, warped facts into formal agreement with a rigid preconception. He is plainly most impressionable, most ready to see and adopt what nature has to suggest; but he has too much self-control, and perhaps too much self-confidence, to allow these suggestions to create any uncertainty in his mind. They guide him, but they do not take possession of him so effectually that he forgets his own personal artistic purpose.

It is interesting, in proof of this, to compare some of his more realistic canvases—like *Water Babies* or *The Nest*, for instance—with such full-blooded fantasies as *The Vine* and *The Island Festival*, and to see how logically he has worked out what he believes to be the object of his art. The difference, after all, is only one of degree; it is only a matter of expression. In his simpler pictures he uses nature with more readiness to be satisfied just with what she provides. In his more complicated pictorial arrangements he selects and adapts, never denying her authority, and never going contrary to her teaching, but choosing out of what she offers only so much as he requires to

perfect his design. It would not be easy to find among modern artists one who better understands the right application of naturalism, or who sees more shrewdly how nature study will help to make imaginative work credible.

But in estimating the value of his work full credit must also be given him for his skill as a craftsman. His pictures have no less authority as technical achievements than as able and ingenious inventions. He has been very soundly trained, and he has obviously known how to profit by the teaching he has received. His education began in 1890 at South Kensington, but in 1891 he went to Paris and worked under Benjamin Constant and Lefebvre, and in 1893 he entered the Royal Academy Schools, where he remained for two years. Since then he has added to his experiences, for in 1903 he returned to Paris and studied for a while under Baschet. The use he has made of these varied educational opportunities is well reflected in the work he has done. He has become an accomplished draughtsman and a facile painter, free from either pedantry of manner or executive carelessness. Ease of expression he has undoubtedly, but it is the ease that comes from a thorough grounding in the necessary rudiments of the painter's craft, and from knowledge of the way in which mechanical details can be controlled, and can be made responsive to the artist's intentions.

One other point must be noted—his freedom

## *A Painter of Gardens : Santiago Rusiñol*

from any marked preference for the tenets of some special school. The tendency, so prevalent at the present day, for a painter to adopt one or other of the fashionable executive mannerisms has not perceptibly affected him ; he does not advertise himself as a follower of some school leader, nor even as a professed imitator of any of the older masters who are held up as fit subjects for the student's worship. He pretends to be neither a modern Frenchman nor an early Italian ; he does not model himself upon Mr. Sargent, Mr. Abbey, Whistler, or any of the other men who are supposed by their admirers to have established immutably the only possible canons of art. He has the courage to be simply himself, and to paint as his instincts tell him he should—and in this way to take the fullest advantage of the qualities which are characteristically his. With his temperament and his powers, with his strenuous individuality and sincere self-reliance, there should be before him a career of remarkable distinction : indeed, almost anything is possible for a man who has at so early an age attained a position which most artists reach only after a lifetime of serious effort.

A. L. B.

**A** PAINTER OF GARDENS :  
SANTIAGO RUSIÑOL. BY  
VITTORIO PICA.

MANY of our readers must remember the exquisite little poem in prose, "Frisson d'hiver," in which that accomplished French poet Stéphanie Mallarmé describes with such extraordinary tenderness the grace and charm of places and things faded and changed by time, and expresses in dreamy and musical language the particular state of mind of those who, tired and disappointed with all the manifestations of our busy, noisy, modern life, love to live intellectually, as it were, in a sort of morbid regret of times and things gone by. To that category of refined and artistic thinkers belongs the Spanish painter Santiago Rusiñol, generally known as the "garden painter," from his pronounced love of painting gardens.

Amongst the clever young school of modern Spanish artists to whom Spain owes the recent renaissance of her painting after the decadence due to the followers of Fortuny, Ignacio Zuloaga stands out pre-eminently as the most characteristic painter of



"UN COIN FLEURI"

BY SANTIAGO RUSIÑOL



“LA FONTAINE DU FAUNE”  
BY SANTIAGO RUSIÑOL

## *A Painter of Gardens: Santiago Rusiñol*

Spanish life, with all its violent and ardent passions. He it was who revived the artistic traditions of the Spanish school, so long dormant after the death of Goya. Joaquin Sorolla y Bastida represents the conscientious study of humble life and the dazzling effects of light on sunny shores. Herman Anglada is the painter of popular Spanish and Parisian scenes, instinct with life and animation. Santiago Rusiñol, on the other hand, appeals to us as a painter full of poetical and suggestive inspiration. This will seem but natural when we realise that Rusiñol handles the pen not less skilfully than the brush, and that his sketches, his short stories, and especially his dramas and comedies, written in rich, picturesque Catalanian, have earned for him a most honourable place in modern Spanish literature.

Santiago Rusiñol was born at Barcelona in 1861; he was not at all a precocious genius, and his art was self-taught. At the age of twenty-five he exhibited his first pictures—typical scenes of the industrial life of Barcelona. For some time he hesitated between figure and landscape painting, producing works of merit but of no particular

originality, yet within himself he felt that he had not yet realised on canvas the artistic expression of his conceptions. He then undertook long journeys, not only in his own beloved land, so varied and picturesque, but also through Italy, France, and Holland, staying for a considerable time in Paris. During his wanderings, as he has himself told us in his volume of impressions, "*Impresiones de Arte*"—which is so beautifully and copiously illustrated with varied and exquisite sketches by himself and his friends Zuloaga and Utrillo—he longed with delight to feast his eyes and his imagination on all he saw, not only on the spectacle of nature but on the marbles, bronzes, paintings, and etchings collected in museums, galleries, and periodical exhibitions of art.

With unceasing pertinacity he toiled for years, ever seeking for new sensations and emotions, and endeavouring through them to find his own aspirations, until one day he realised his inspiration in an old garden of Grenada, and then was his genius suddenly revealed to him by the spectacle of gnarled and knotted trees gilt by the ardour of an

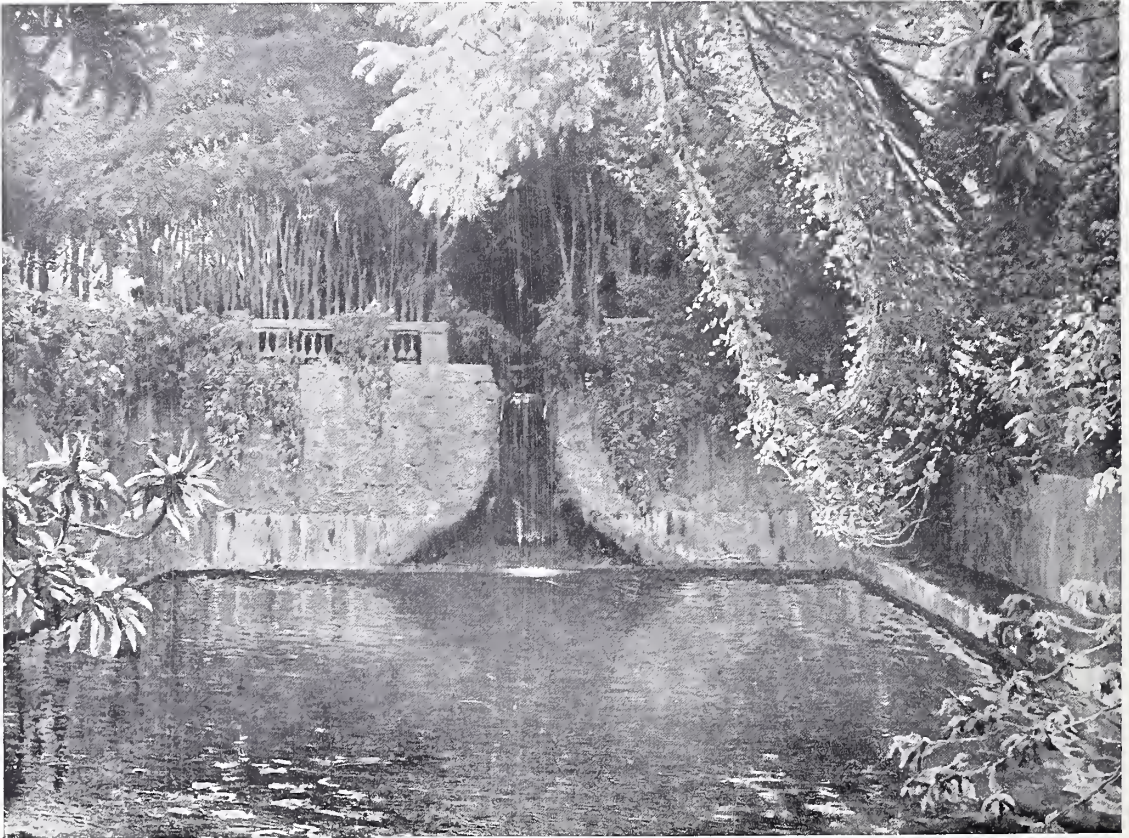

"UNE RETRAITE TRANQUILLE"

BY SANTIAGO RUSIÑOL

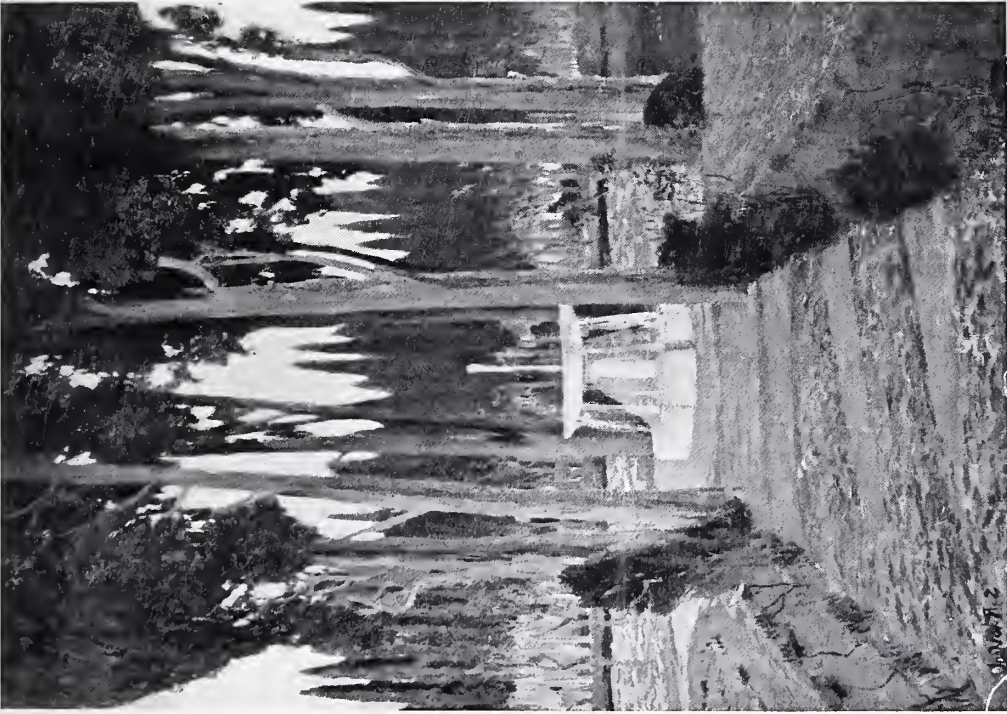

“LES CYPRES DORÉS”

BY SANTIAGO RUSIÑOL



“ARCHITECTURE ARBOREALE”

BY SANTIAGO RUSIÑOL

## A Painter of Gardens: Santiago Rusiñol



“LE PETIT BASSIN DE FONTAINE”

BY SANTIAGO RUSIÑOL

Segantini, nor in the undraped human forms in the placid twilights of Ménard; but rather he takes the nature that man knows and loves, with its gardens and terraces created for his hours of peace and pleasure. Rusiñol has the secret gift of vividly bringing before us the figures of those who lived, loved and suffered there, an hour, a year, or a century ago; the personages, young or old, who rested under the shadow of the trees, who gathered flowers in spring or fruit in autumn, who strolled in the shady walks now deserted and moss-grown, who gazed on the statues

now fallen and shattered, autumn sunset, by falling walls, broken marble steps, by fragments of moss-grown statues and walks overgrown with weeds, and by the dreamy sadness of his own poetic imagination. From that day forth all, or nearly all, his artistic activities were utilised in reproducing, by the aid of his masterly brush, the gardens of all the great and noble cities of his beautiful country. He found his inspiration not only in princely demesnes or in modest little gardens on the mountain slopes, but also and chiefly in avenues and walks amongst ruins and fountains, which although now neglected and abandoned by man yet reveal here and there traces of their pristine grandeur. Nature as reproduced by Rusiñol is not nature in its noble majesty, nor in its simple grace, embellished by sun, poetised by moonlight, dramatised by tempest, as so many great masters have portrayed it, from Ruysdael to Constable, from Rousseau to Monet, in which nature is exalted for its noble self, and in which human beings play quite a secondary part, as in Fontanesi's pictures; nor does it take a fantastic form as in the *Wood Nymphs* of Corot, nor as in the symbolical apparitions on the Alpine heights of

and on the chaste fountains now silent and dry. Alas! all are gone; but Rusiñol has the peculiar

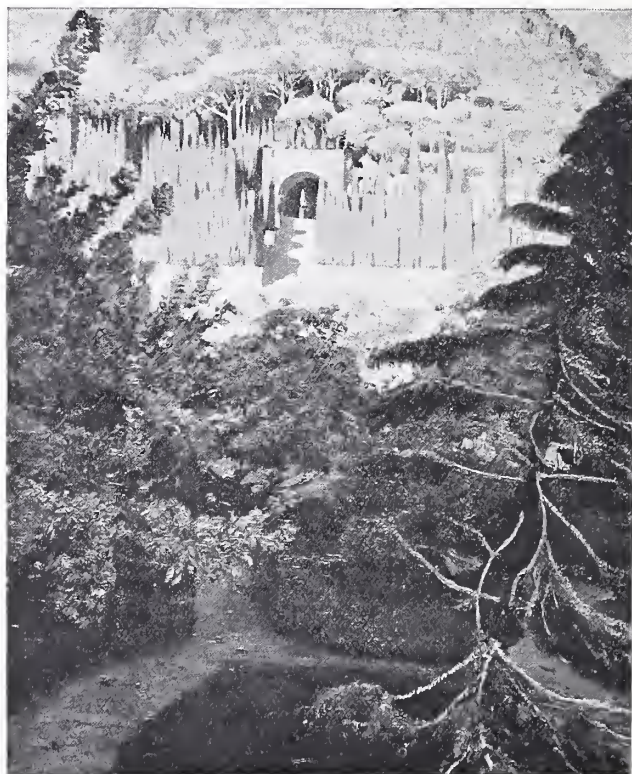

“SILENCE DE MIDI”

BY SANTIAGO RUSIÑOL

## A Painter of Gardens: Santiago Rusiñol

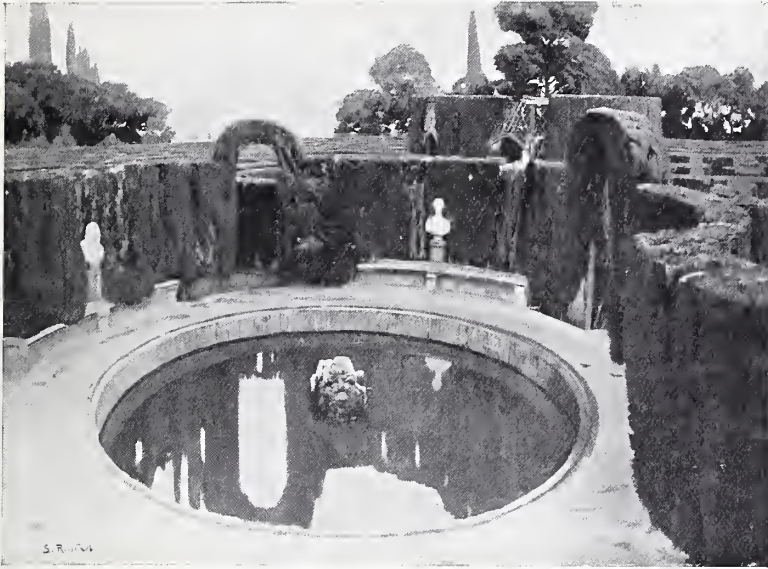

“LA LABYRINTHE, BARCELONE”

BY SANTIAGO RUSIÑOL

talent of reviving and peopling the old scenes, and in that lies his special charm, his extraordinary poetical fascination.

To repeat year after year in dozens of pictures the same pictorial topic and never to weary his admirers constitutes in itself an absolute wonder, and Rusiñol exhibited thirty-two of his garden pictures in the gallery of L'Art Nouveau in 1899, yet he was able to avoid monotony. Wherever he has shown his works he has carried all before him, whether in Madrid, Barcelona, Paris, Brussels, Venice, or St. Louis.

The secret of such a marvel lies not only in the graceful ease with which the painter, with very few elements more or less identical—such as a portico, a flight of marble steps, a shelving lawn, a group of trees, a flowering hedge, a lake mirroring the azure of a sky flecked by the white of a few clouds, or a playing fountain—makes up an exquisite picture. Rusiñol excels not only in the directness and accuracy of his draughtsmanship, in the masterly harmony of his tints, now dull, now exuberant, but especially by keep-

ing himself ever in contact with Nature, observing her continually with loving eyes, and never by any chance falling into mannerisms. Thus, through the sincerity of his vision, he avoids the risk of becoming wearisome by his sameness. Before each new canvas of Santiago Rusiñol we feel ourselves conquered by the potent fascination which permeates it, be it his *Labyrinth of Barcelona*, with its mazy paths and marble statues, before his arboured *Court of the Alhambra of Grenada*, from a little mountain garden full of flowering almond trees to a noble marble terrace on which the peacocks are preening themselves, from a gloomy avenue of cypresses to a peaceful rustic garden. The lights of each and every one of the exquisitely tender creations of Rusiñol delineate and so forcibly bring home to us scenes of Spain in olden times, that we seem to know and love the souls of those who have departed thence, whether heroic or mystic, tender or passionate.

VITTORIO PICA.



“UN JARDIN CLASSIQUE”

BY SANTIAGO RUSIÑOL

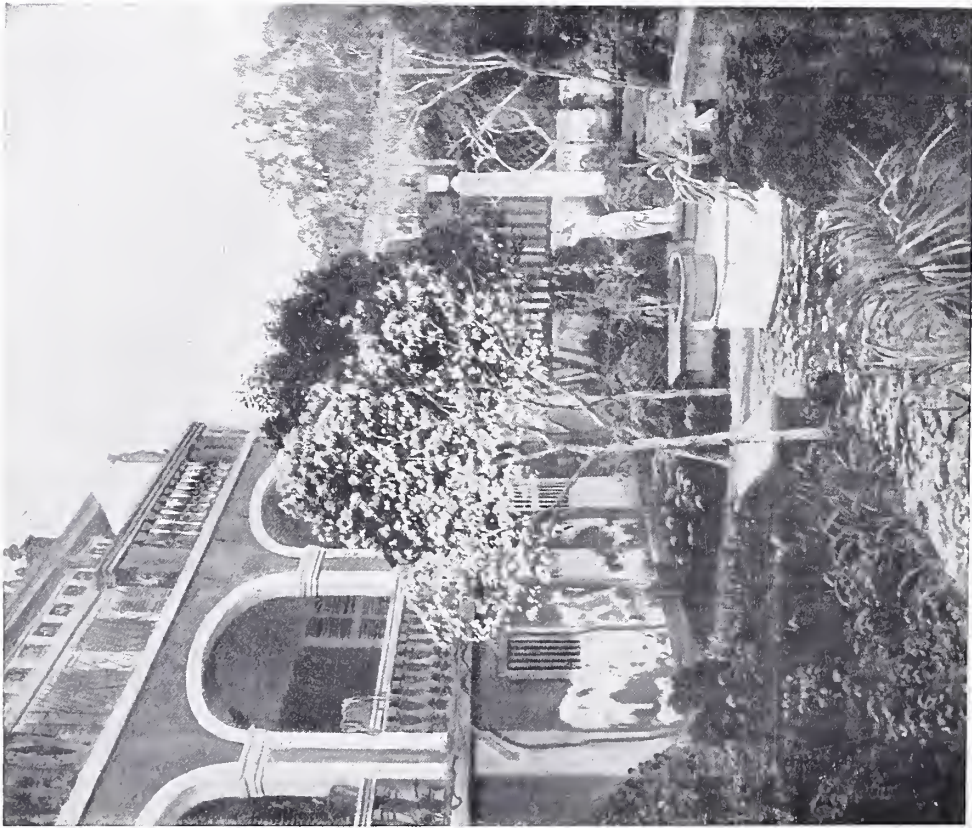

"VILLA FLEURIE"

BY SANTIAGO RUSIÑOL

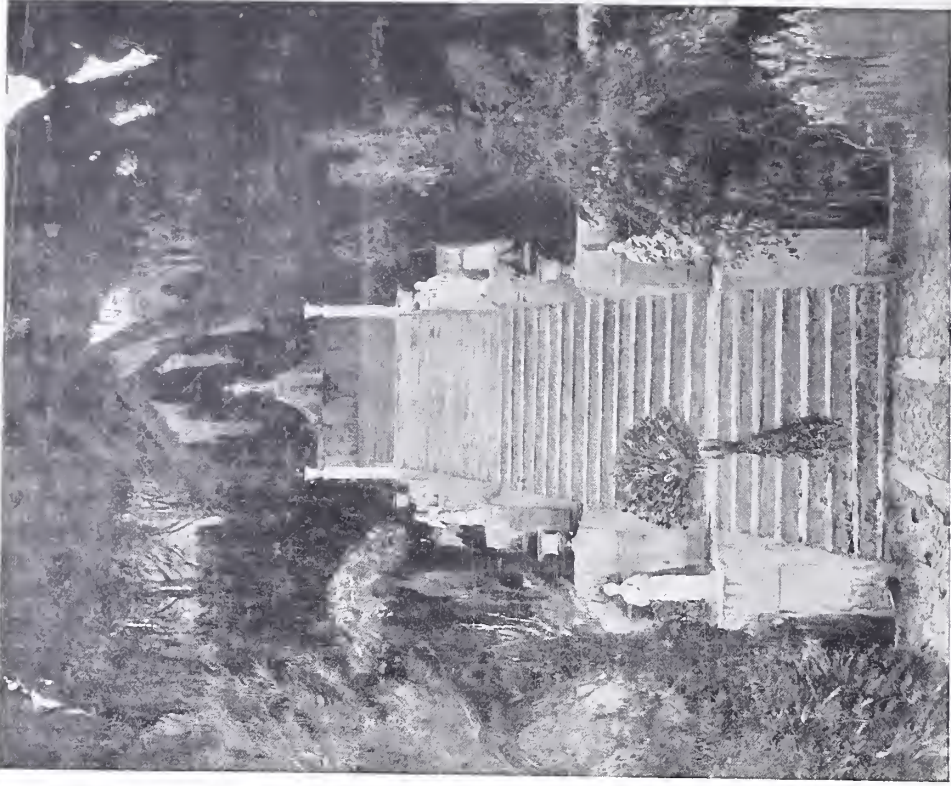

"DANS UN JARDIN SEIGNEURIAL"

BY SANTIAGO RUSIÑOL





"NOTRE DAME DE PARIS" (OIL)

BY E. L. GILLOT

**L** OUIS GILLOT: PAINTER AND ENGRAVER. BY HENRI FRANTZ.

ONE of the most noted and most personal exhibitors at the Société Nationale des Beaux-Arts in the present generation of painters—which is junior by several years to that of the Cottets, the Simons, the Dauchez, and the Ménards (the second generation we owe to the National Society)—is M. Gillot, who would seem to be carrying on the tradition left by the delightful succession of *petits maîtres* of the nineteenth century—"little masters" often possessed of genius, such as Jongkind, Hervier, Boudin, and Lépine. These painters, who first and foremost were masters of the picturesque, preferred, just as M. Gillot prefers, the more direct and intimate view of things to those other aspects hitherto generally studied.

Gillot is enamoured of the big towns of the North, with their cloudy skies and their grey waters; these and the flowers and the quays of Paris and of Rouen

artist's imagination; yet what a truly beautiful thing he has produced therefrom; how completely he has succeeded in creating that precious element—mystery! The vessel stands before us in the phantasmagoria of a November fog, its dark bulk towering above the watery quay where lusty porters are busy loading her holds with cases scattered about pell-mell. And beyond is the dome of the Institut, vaguely showing through the heavy mist.

In Gillot's recent work one notes a particular



"FÊTE AUX INVALIDES" (PASTEL)

BY E. L. GILLOT

## Louis Gillot

tendency to seize and to fix the essentially modern and fugitive aspects of contemporary life. Thus he was fascinated by the *d cor* of the Universal Exhibition of 1900, particularly when on summer nights or autumn evenings this "setting" became clad in the mystery and the hazy imprecision which the artist loves. In his *Fête aux Invalides* (page 105) he shows a swarming crowd of striking reality squeezing along past the motley booths, beneath flags flapping in the wind and garlands of flowers.

Impulses such as those expressed in this work have led M. Gillot to make some of the most interesting rescarches of his career, have served as starting point of an entire new series of production. M. Gillot was justly struck by the poverty, the ugliness, the lack of character and truth in "commission" pictures, wherein the artist is required to commemorate some great event—the opening of an exhibition, the reception of a crowned head, or some popular festival, or other similar event. Not without reason have curses been hurled for years past at the horrors of official painting!

Gillot asked himself would it not be possible to give a newer form to pictures of this kind, and in a certain degree to recall the setting and the sentiment of the scene depicted. He resolved to try for himself. When M. Loubet visited London he followed the various stages of the historic journey, and noted all the phases of the reception offered by the City of London to the President of the Republic. M. Loubet entering the Guildhall afforded him an admirable subject, with something *intime* in the ancient courtyard, glittering with uniforms and crowded with spectators. At once he made a rough sketch of a scene well worthy of attracting the gaze of the colourist, and under the direct influence of this vision he painted the excellent picture which was subsequently displayed at the Société Nationale. This work achieved great success, for one recognised therein the rejuvenescence of the "official" picture, and it was immediately bought by the State for the French Embassy in London, where it now is.

M. Gillot began as an engraver. While still



"BATEAU DE LONDRES AU PONT DES SAINTS-PÈRES, PARIS" (OIL)  
(Musée du Luxembourg)

BY E. L. GILLOT



*(Musée du Luxembourg)*

“L'ENTRÉE DE LA RUE DAUPHINE”  
(MONOTYPE). BY F. L. GILLET

## Louis Gillot



"DIEPPE" (PASTEL)

BY E. L. GILLOT

quite young he was attracted exclusively by painting, but his parents' wish compelled him to choose a more productive calling. At the same time he painted, almost "on the sly," sent in his work to the Salon, was rejected, and set to work again with increased ardour. In 1889, after many disappointments, he had his first picture accepted for the Salon des Artistes Français; it was a Paris scene—*La Place Pigalle*—and already affirmed his predilection for the animated, picturesque and lively scenes of the capital. In the following year he was rejected—one knows not why. Discouraged by the routine spirit of the old Salon, the young artist resolved to submit his efforts to the Nationale, and he has since remained one of its most constant exhibitors. For three years he displayed paintings and pastels there, and became an Associate in the last-named section. During this period—which was one of hard work and research—he painted not only a large number of pictures, but also a decorative panel for the Municipal Council Chamber of Issy-les-Moulineaux. In 1902, after many experiments in monotype, the artist was permitted to exhibit a score of them in one of the galleries at the Salon. Thereby he proved his real mastery of this charming method, which is always well adapted for the rapid "fixing" of fugitive impressions, and for recording pictorial thought and preserving its first freshness.

The monotype, while executed in oils and preserving the force of touch obtainable by that medium, also resembles the pastel with its

velvety tones and the water-colour in its level transparency. A monotype proof is a work of art, like a water-colour or an oil painting, not only because the proof is unique, but above all because it is the original itself transported on to another substratum whereon retouches are possible, and the value of the proof will turn out to be in inverse ratio to the number of such retouches. Repeated experiments and infinite pains have furnished us with simple and fundamental data thereon. Rarely does chance intervene to pro-

duce the unexpected, or to modify the final result, save in the case of a study.

M. Gillot may be regarded as the real creator of the monotype, and it is only right that two of these works should figure in the Luxembourg.

HENRI FRANTZ.



"LA MAISON DE LA MATINEUSE" (OIL)

BY E. L. GILLOT

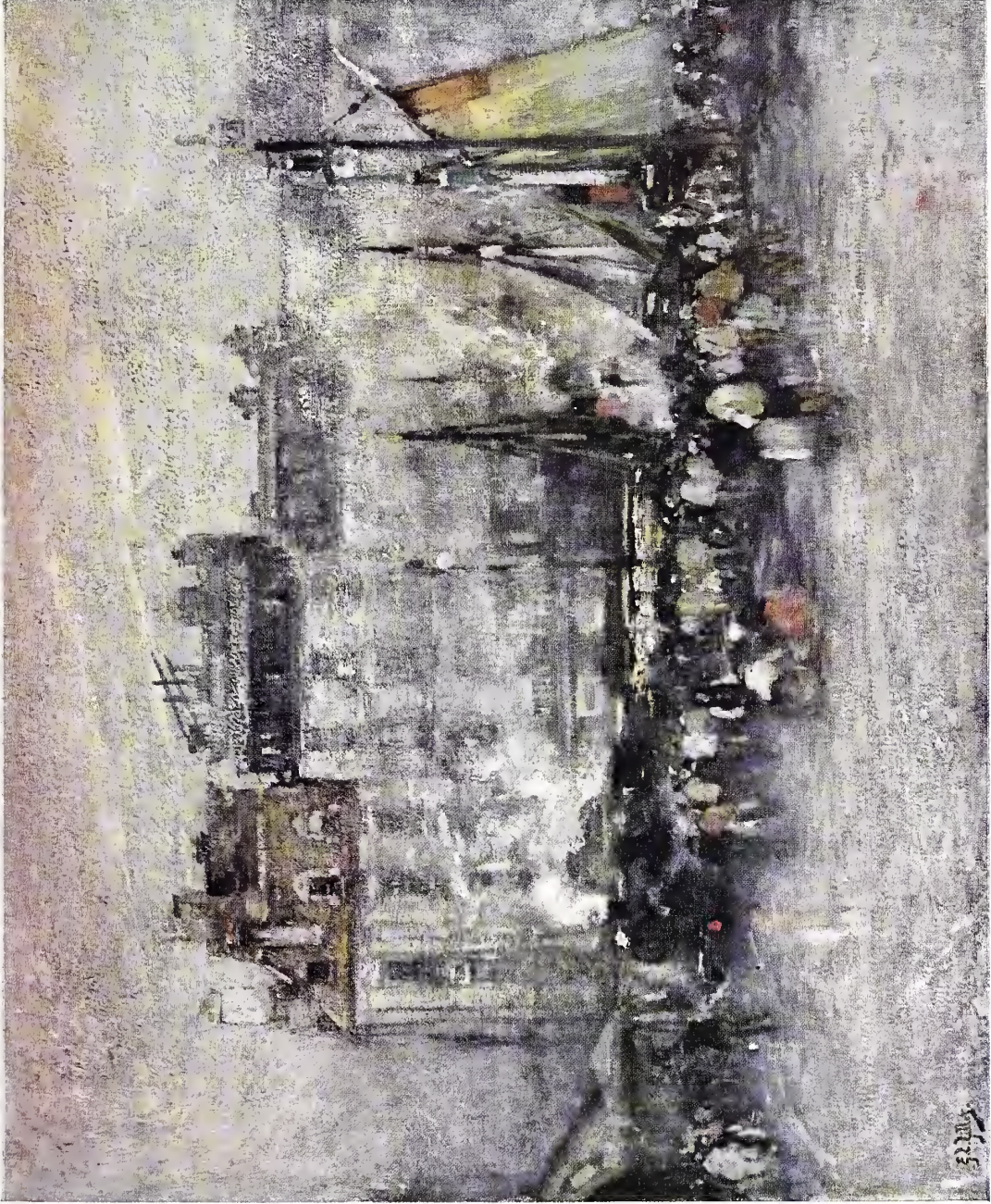

“LE DÉPART DU TRAIN DE MARINE.” BY E. L. GILLOT.



## *Bits of Old China*

**B**ITS OF OLD CHINA. BY  
INGLIS SHELDON-WILLIAMS.

THERE was once a Chinese Mandarin who built himself a house in the old walled city of Shanghai, hundreds of years ago, and laid out the cramped space about it with many artfully designed paths and terraces, grottoes and subways, where, in the space of fifty square yards, one may walk for half-an-hour without retracing one's footsteps.

Perhaps this called for more art and ingenuity than even Kubla Khan might boast, with all the wide valley at his disposal to deck and beautify for a setting to his stately pleasure dome. From innumerable terraced standpoints, from above, from below, through doorways carved with an amazing richness and intricacy of design and detail the eye may gaze in turn on every elaborated angle and perspective of the dainty dwelling poised on its conventional rock-clouds that seem to float with their airy burden on the surface of a little lake, reflecting the complex and bewildering succession of curve on curve of heavily

corniced roofing, each tiled and sweeping line crowned from eave to roof-tree with its interlaced network of carved foliage and symbols, each pinnacle and apex poising little sitting, dancing, or standing figures, dragons and emblems, wrought with as lavish a care and completion as the carved and gilded woodwork above the round doorway that gives upon the inner court, or the sinuous folds of the serpent that crowns the coping of the outer wall.

Here, in the heart of squalor, this perfect bit of bric-a-brac endures unchanged, the whole no bigger than a Surrey cottage; so small a gem set in the midst of the crammed and uncouth city, neglected by the myriads without its walls, but seemingly immune from decay, it appears to brood in a rapt and self-absorbed silence on past pageants and pomp.

The wise painter will look on such a thing as this with that side of his mind in the ascendant that absorbs the mystic poetry and philosophy of unpaintable things, his hands will be idle; his mind registering with an almost painful speed and vividness, impressions that have no relationship with the technical problems of his craft. Long ago, in the first half-second, the wholly satisfying effect of weathered ivory and ancient parchment in a world of turquoise blue has enthralled his colour sense; in the midst of a scheme of subtlest blue and gold he begins to think, but not along lines of tone and values, intricacies of perspective design and what not—there is no room here for these elementary problems or the common-places of imitative execution, at best a meretricious sacrilege. Rather he ponders over the marvellous brotherhood of great designers; separated by thousands of miles, almost by thousands of years, the work of the ancient architect of the east would stand in complete harmony beside the most precious example of Gothic art; with every sentiment, every tradition,



“A SHANGHAI PEDIAR STOCKTAKING”

BY INGLIS SHELDON-WILLIAMS

## *Bits of Old China*

every instinct but one in complete antagonism, the gulf of time and space is bridged, the inseparable relationship vindicated between the craftsman of the West and the Farthest East, by the perfect unity of aim, the determination to satisfy to the utmost the rigorous exactions of a finely developed æsthetic sense, indulging its appetite to satiety by the most prodigal expenditure of time and toil, weighing no questions of profit and loss, and unconsciously insuring thereby through the centuries the accumulating compound interest that accrues to every world - masterpiece done with that single-mindedness of vision that sees in the perfected work alone the richest desirable recompense for travail of mind.

Such oases, then, among the swarming hovels and alleys of a Chinese city might best be studied with the consciousness that here is no exclusive preserve for the painter's special craft. He may attempt a comment, a diffidently offered side-light on the psychology of a people whose ways have long puzzled and fascinated the Western mind ; fortunate if he can register the merest suggestion of the mystic and elusive eloquence that seems to whisper in broken numbers from the deserted courts and corridors. He, no more than others,

holds the key to the pervading mystery ; here and there a thought is written in characters all thinking humanity may read and understand, only to be obscured again in a maze of half-suggestion tangling to utter incomprehensibility, enticing the venturesome explorer farther and farther till the search is perforce abandoned, and the baffled mind falls back on the more obvious attractions, the study of moods and characters in the half-indifferent, half-resentful crowds, and the surface picturesqueness of everyday sights and happenings in a city where modern progress, modern conditions, seem meaningless terms.

The national long blue smock in various and pleasing stages of discolouration glances in and out among the drab and nondescript garments of the multitude ; scantily-clad, slender-limbed coolies, with knit and shining muscles and tendons taut as fiddle strings, trundling wheelbarrows loaded with merchandise or passengers sitting sideways as in a jaunting-car, jolt their vociferous way over ruts and cobblestones ; every nook and interstice in the milling crowd is filled with children, plump and copper-coloured children, and children wizened, yellow and old ; the faces of their elders ranging from the smooth, almost feminine, type of soft-



“ WEDDING PROCESSION IN THE WALLED CITY, SHANGHAI ”

BY INGLIS SHELDON-WILLIAMS



## Bits of Old China

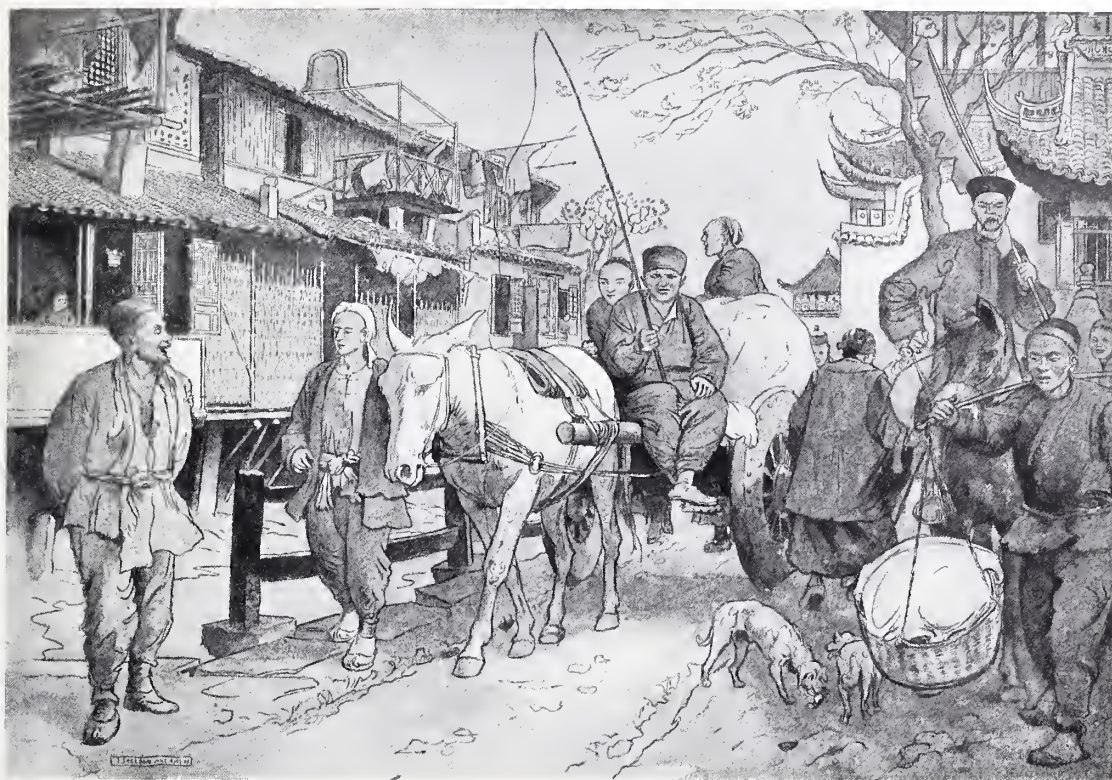

“SHANGHAI TRAFFIC”

BY INGLIS SHELDON-WILLIAMS

stepping pig-tailed “boy,” and the more rugged countenance of the lower caste coolie, his queue coiled on a head bare or tied about with white or coloured rag, to the finely chiselled, often almost classic, features of the Manchu from the North.

Women with feet free from the cramped confinement suffered by the higher classes share in the labour, and enjoy their immunity from the social restrictions that regulate the coming and going of their nobler-born sisters; cheery, good-tempered looking and hardy, they seem less taciturn than their menkind, and gossip and gesticulate at windows, loop-holes and alley corners with the freedom and eloquent gesture of an east end housewife. On the parapets of the frequent bridges that span sinister, indigo-coloured streams, knots of idlers bask in the sun; now and again, with a flash of sky-blue, purple and gold, some dignitary flits through the sombre-coloured crowd like a dragon-fly, or a gorgeous wedding procession pours its glittering stream across the bridge and wakes to a momentary, half-hearted response the sullen waters below.

In China one may know each detail of the couple's plenishings and wedding presents, as the entire contents of the future home is borne in procession round

the town for all the world to see; only the bride is invisible in her closely-draped and gorgeously-appointed palanquin.

Before these subjects, the busy but unhurried life along the quays, the solitary, brooding temples with red and gold lacquerwork dimmed by the dust of years, and courtyards buried in weeds, alluring glimpses of Rembrandtesque interiors, towering wooden shop fronts carved from pavement to pinnacle, with panels of screening foliage filled with figured birds and creeping things; the teeming bazaars, the spattered colouring of the bird market with its vistas of cages swung along the booths: among these and a thousand other things the painter may well pause in bewilderment as to the means whereby some analysis and selection may be arrived at that will yield a few intelligible, unconfused records from the profuse mass of material spread abroad on every hand. At one moment the eye dwells with satisfaction on large and sweeping lines, at the next the attention is arrested by every resource of the metalworker's craft expended on some comparatively unimportant detail, but, once seen, the impression of thoroughness in every part remains upon the mind, for the Chinaman lacquers the bottom of the box,

## Bits of Old China



“IN THE BIRD MARKET OF THE WALLED CITY, SHANGHAI”  
BY INGLIS SHELDON-WILLIAMS

and things out of sight are finished for love, or conscience's sake.

Huge black characters, splashed with easy freedom on white and yellow walls, are, one supposes, the equivalent of our commercial posters; their meaning is unintelligible and one rests content with the effect of broadly rendered arabesques. Except for these advertisements, the unassuming, almost humble, thoroughness of all things—sufficient for the purpose, and embellished as far as that purpose will allow, and no further—stands in monumental contrast with the cheap and perishable materials poured by the hundred gross into the port from the hold of every merchantman from western shores, and spreading through the country that deteriorating influence upon the national taste and traditions that has already made its mark in Japan; such things must apparently come in the wake of progress and

the offended eye twelve-foot pictures of red and white cows on green fields topped by square yards of rankest blue—exquisitely woven abominations. Not till after much pressing will he unfold from hidden corners those cherished treasures rescued from the great loot, and stand before you an artist false to his craft. At Shan-hai-kwan, on the



“DULL TRADE: CHINESE PEDLAR IN THE WALLED CITY, SHANGHAI”  
BY INGLIS SHELDON-WILLIAMS

the purity of native art suffers accordingly.

A visit to a Peking factory of *cloisonné* ware reveals signs of the destructive tendency of foreign influences and innovations. Abandoning old designs the manufacturer, unable to completely adjust his art to new and ill-assimilated ideas, produces offensive combinations of Western realism and Oriental convention; wrought with the same perfection of craftsmanship they are depressing travesties of a time-honoured art, and mournful witnesses to an overreaching commercialism.

Again, the fashionable silk merchant flaunts before

## *Some Polish Artists of To-day*

Manchurian border, where the Great Wall ends in the Yellow Sea, it is pierced by the northern railway, and so these things have come about ; you can get from London to Peking in a few days now, but there is a price to pay for passing through that Wall that cannot be settled with Russian roubles.

An impression is abroad that anything will go down with the visiting foreign devil, who must be tolerated for the sake of his gold, and tons of costly rubbish are disposed of to the buyer of small discrimination, who sees nothing but the highest art in all things Oriental, and places his orders wholesale at the showy emporiums of the Treaty Ports.

Failing a knowledge of, or the time to search for, the hidden genuine treasure, there is more profit to be found in roaming about the native bazaars, groping in dark and dusty corners of tiny shops, and ransacking the accumulated oddments that form the stock-in-trade of the obscure native pedlar, who receives with complacency a tenth of the price demanded and makes no charge for admission to the world of magic and enchantment where Aladdin still lives and has his being.

In such ways one may store up a host of weirdest memories that touch the imagination as lightly as the hinted contact of a moth's wing on the cheek, and come and go with the elusive aroma of a vanishing morning dream. For it is all a strange, half-real dream, this probing into the back centuries, and it is there to be dreamed by all who care to shun the everyday common-places of the East where the touch of the Western hand has brushed away the bloom ; a dream to be embalmed in its native spices, to endure for all time against ignoble decay when more garish surroundings once more importune the mind.

And the small and inconsiderable treasure and priceless fabric alike become Magician's Lamp or Magic Carpet to waft the

imagination at will back among scenes that are lived over again under the mellow influence of an old recollection, gradually blending into the myth and mystery of a people's inscrutable past.

INGLIS SHELDON-WILLIAMS.

### NOTES ON SOME POLISH ARTISTS OF TO-DAY.

To properly understand modern Polish art one must study it in the land itself, and have personal acquaintance with the artists. The Poles have suffered much as a nation, and the sorrow they have endured has not failed to leave its mark on their art. I speak of them as a nation, because the spirit of nationality is very strong in the Pole, whether he owes political allegiance to Russia, Germany, or Austria.

In these notes I propose to speak only of some of the leading artists belonging to Galicia or Austrian Poland. This does not imply that the artists of one political division of the country hold aloof from those of others ; such is far from being the case, for the society of artists founded some ten



"AN UNCOMMON GARDEN"

BY JOSEF VON MEHOFFER

## Some Polish Artists of To-day

years ago, and going by the name of "Sztuka," includes among its members many who live in Russian and German Poland.

Among present-day exponents of the national feeling, Jacek Malczewski occupies a leading position. He was born in 1855 in a small place in Russian Poland, but like many of his compatriots has chosen Cracow as his home, for in Galicia the Pole is free. A man of passionate, poetic feeling, versed in the literature and history of his country, and filled with an ever-glowing spirit of enthusiasm, he passes his days in the silence of his studio, living in a world of his own. He belongs to no community of artists, but the pictures he from time to time gives to the world show him to be an ardent patriot. One of the most beautiful and touching of his works is that illustrating the death of a young wife in a Siberian hut, the incident being taken from the patriotic poem "Anhelli," by Julius Slowach. This *Death of Ellenai* touches us to the quick, the sorrow of the young husband in its desperate passion finds an echo in our hearts, and we feel with him as, in a fervour of undying love and gratitude, he bestows a farewell kiss on the foot of his departed companion. *Genre* subjects such as this are, however, not the only things Malczewski paints. He is a mystic who sees

visions all around him, and who holds that just as everything in nature bears an affinity to all other things in nature, so also do human beings to others of their kind. The picture called *The Beetle*, reproduced on p. 125, will serve as an illustration of this side of his art. It is the portrait of a young girl gazing intently on the movement of a beetle slowly crawling over her hand. Looking over her shoulder is a youth—her "other self" or "affinity." In some of his pictures this affinity seems to take the form of a protecting angel, not merely swaying in the air, but alive and tangible: but whatever form it takes it is never obtrusive.

Ferdynand Ruszczyz, too, possesses a poetical nature, subtle and deep, but his characteristics differ widely from those of Malczewski. His works are full of what the Germans call "Stimmung," a quality which is manifest alike in such glimpses of peaceful home life as he gives us in the *Interior*, reproduced here (p. 125), as in those of his pictures in which the more rugged life of the peasantry is portrayed, though at the same time there is not lacking a certain tendency to style. Henryk Szczyglinski's *Homeward* also shows this tendency; there is no lack of originality here, either in conception or treatment, and the rendering of atmosphere is admirable.



"SNOW SCENE"

BY JULIAN FALAT

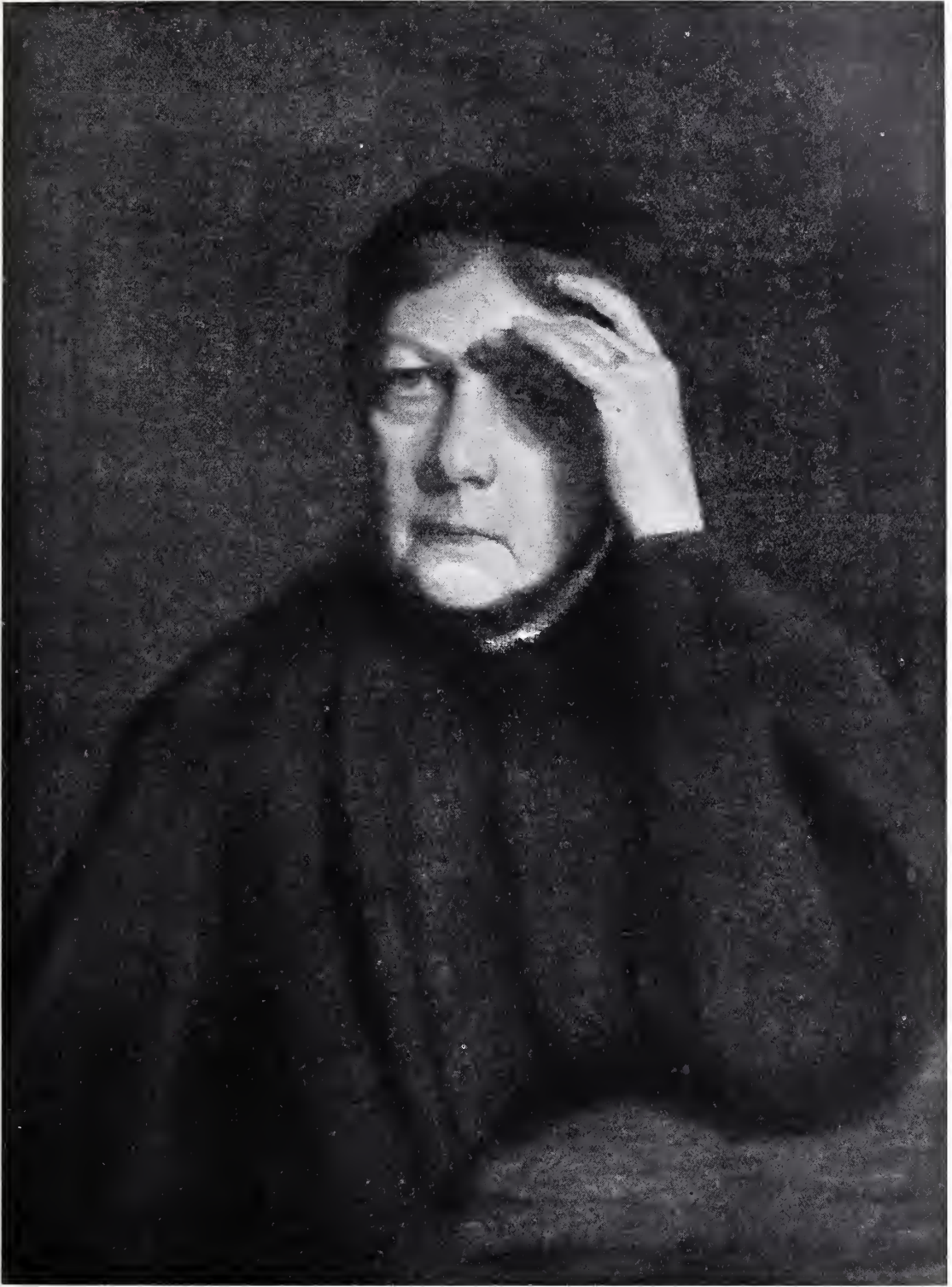

PORTRAIT OF THE ARTIST'S  
MOTHER. BY T. PANKIEWICZ

## Some Polish Artists of To-day



“THE MUSE”

BY JOSEF VON MEHOFFER

Stanislaus Wyspianski, besides being a painter, is a poet, whose works have a permanent place in the literature of his country. He is, moreover, a craftsman, a designer of stained glass windows, and a decorator. He lives in a little place in Galicia awaiting the end, which is slowly but surely approaching, for his work on earth is over. In his designs for stained glass windows he shows a *penchant* for flaming colours, which seem to come out from and envelop the shadows like tongues of fire. But in his pictures he is more subdued. He loves to depict the peasant people among whom he lives, and who with their rugged faces, full of character and expression, and their traditional costume, appeal powerfully to him.

Another strong and rich talent is that of Professor Josef von Mehoffer. He,

too, is a decorator, an arts-and-crafts man, a designer of furniture, but pre-eminently a designer of stained glass windows resplendent in rich colouring, interwoven with threads of gold. His fancy is exuberant, his expression gorgeous, and well calculated to stimulate religious fervour. The cathedrals of Plock, Cracow, Fribourg, and other cities contain windows designed by Professor Mehoffer, who can count himself a leader in this domain of art. In his pictures, too, his fancy is poetical and rich, yet he always knows when to restrain it. In such a picture as *Ein Seltsamer Garten* (reproduced on page 115) he gives play to his joyful fantasy, and the colouring is exquisite. The same qualities the artist also shows in his dreamy picture, *The Muse*. In his portraits Professor Mehoffer loves daring colours, reminding one in this respect of the Spanish school.

Professor Falat is director of the Imperial School of Arts in Cracow, where many of the other Polish artists are teachers. He, too, possesses marked individuality. He



“THE PET”

BY KASIMIR SICHULSKI



"A RUTHENIAN PEASANT GIRL," BY THEODOR AXENTOWICZ.







14. 1911  
PORTRAIT OF A LADY  
BY TH. AXENTOWICZ

## Some Polish Artists of To-day

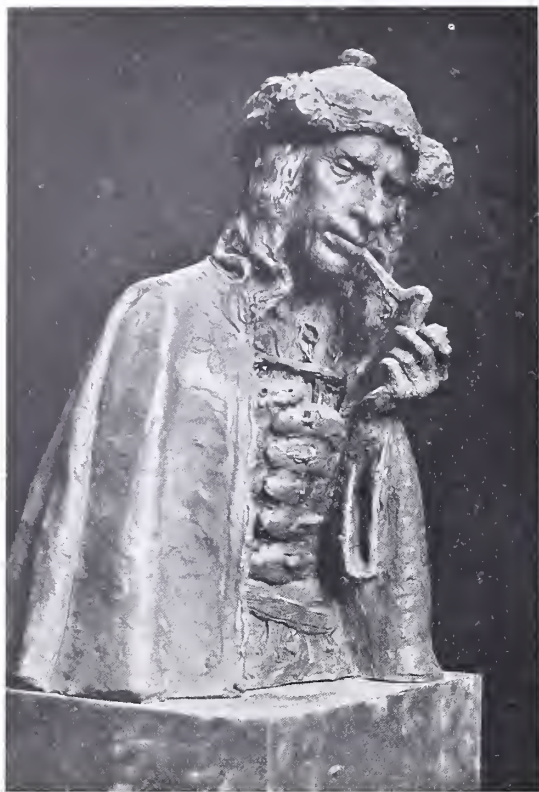

"A ZAKOPANE MOUNTAINEER"  
MODELLED BY KONSTANTY LASZCZKA

has painted many hunting scenes, full of life and movement, for hunting is his chief recreation. He also takes a special delight in spending long hours in the depths of winter searching the masses of snow and studying their lines. Galicia offers her artists almost as rich a harvest of snow as do countries farther north.

Stanislaw Czajkowski is a landscape painter of indubitable merit. He chooses intimate bits of country life, such as in the picture here reproduced (page 126), which represents an old farmhouse, breathing a delightful atmosphere of peace and rest.

Jan Stanislawski, who died some few months ago at the early age of forty-four, did some excellent work. He had a predilection for small landscapes, filled now with gloomy sadness, now with radiant brightness, for his was a loving, variable nature. His work is so fine, that it is practically impossible to reproduce it; it shows

a keen love of nature and intimacy of treatment; the colouring is especially captivating.

Josef Chelmonski is a painter of game and wild fowl, storks in flight, and like subjects. He, too, has breadth of treatment and sure draughtsmanship. His art is thoroughly healthy, and he has remained national spite of the fact that he has lived for a long time in Paris, as have other of these artists.

Kasimir Sichulski who exhibits at the Vienna Hagenbund, and whose work has been already referred to in *THE STUDIO*, also possesses a strong and original talent: he is one of the youngest of the present generation of Polish artists, and studied at the Cracow Academy. His favourite subjects are those of peasant life. His method savours somewhat of fresco; his talent is undoubted, and it will be interesting to watch the outcome of his stay in Paris, where he is at present studying. His colouring is certainly crude, but nevertheless his work is always powerful.

Josef Pankiewicz is an artist of rare gifts. He has painted many pictures of Cracow, which is a mine of wealth to the sympathetic artist. One of these pictures, that of an old Gothic church in

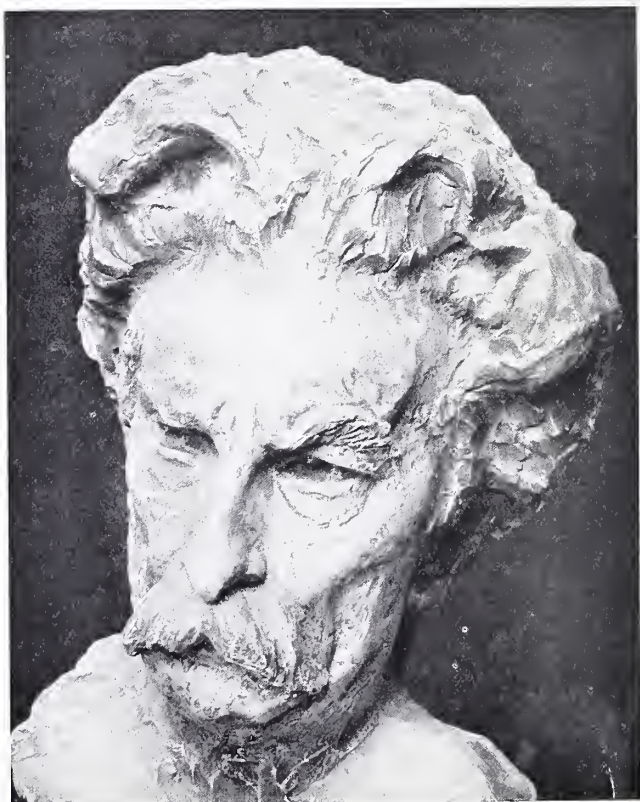

HEAD

BY KONSTANTY LASZCZKA

## Some Polish Artists of To-day

Cracow, with copper beeches before it, is especially attractive by reason of its rhythm and capital rendering of the contrast between the grey of the architecture and the brown-reds of the trees. But

nificent. It is now being restored as far as possible on its original lines, and the Emperor is contributing a yearly sum out of his privy purse towards its restoration. Makarewicz finds his chief delight in painting national types such as form the subject of his picture here reproduced, which is an excellent example of his methods.

Professor Theodor Axentowicz has travelled in many countries, including France and England. He favours pastel drawing, but he seems to have two distinct modes of expression, one Parisian, as shown in the *Portrait of a Lady*, the other purely national, as shown in his picture of a Ruthenian girl, of which a coloured reproduction accompanies these notes. In this *Ruthenian Peasant Girl* we have a characteristic delineation of a Galician female—one of those who once a year come from the moun-



PORTRAIT STUDY

BY J. MAKAREWICZ

even better than his landscapes is the picture of his mother (p. 117), which shows great depth of feeling. The breadth of treatment and the arrangement of the light suggest the influence of Rembrandt, though he is no blind follower of the master, for this portrait has its peculiar and national vein. Pankiewicz is also excellent as a graphic artist.

Julius Makarewicz at the present time is doing but little exhibition work, for he is engaged in decorating the old home of the Polish kings. Before the residence was transferred to Warsaw, the "Wawel," as the palace is called, must have been truly mag-

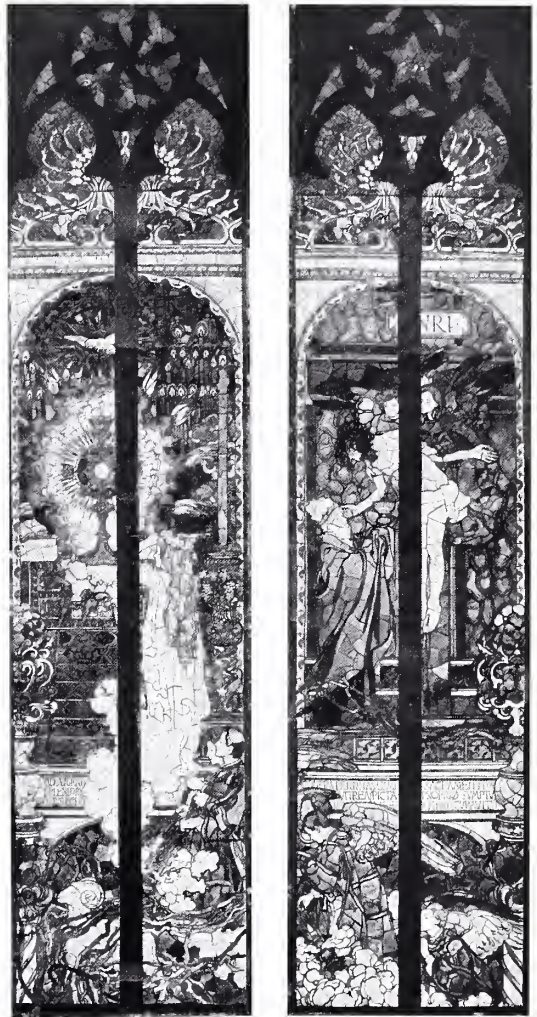

WINDOW IN FRIBOURG CATHEDRAL

BY JOSEF VON MEHOFFER



“HOMEWARD.” BY  
HENRYK SZCZYGLINSKI

## Some Polish Artists of To-day



INTERIOR

BY FERDYNAND RUSZCZYZ

tains to fetch their supply of holy water, and their candles to burn on holy days and saints' days. In this picture Prof. Axentowicz is at his best.

There are many other Polish artists worthy of note, though there is not space sufficient to do more than mention names; for instance, Stanislaw Kuczborski, Karol Maszkowski, Kasimir Pochwalski, a well-known and appreciated portrait painter who is now a Professor in Vienna, Karol Frycz, Leon Wyczolkowski, who paints delightful bits of old Cracow and who is also a graphic artist, and Olga Boznanska, who ranks as the first woman artist in Poland; nor would it be out of place to mention Jan Styk, the illustrator of "Quo Vadis," though he lives in Paris and does not exhibit with the "Sztuka."

It remains only to say something of the two chief sculptors of Poland, W. Szymanowski and Professor Konstanty Laszczka. The former began his artistic career as a painter, and only took to sculpture after settling in Paris,

where he has lived for many years. His first essays in plastic art were small figures, which notwithstanding their size, were not at all lacking in vigorous treatment. His *Maternité*, here reproduced, is representative of his best work. Professor Laszczka also possesses great individuality and rare talent for expressing it, though his subjects are widely different from those of Szymanowski.

From what has been said, and especially from the accompanying illustrations, it will be gathered that Poland is making good progress in art. The old ideas and academic methods imported from

abroad are fast being discarded, and giving place to a vigorous and healthy, and at the same time, national art, which need not be ashamed of being seen side by side with that of other countries. It is gratifying to record that wherever the Poles have exhibited, they have met with warm welcome—more particularly in Vienna, where most of those



"THE BEETLE"

BY JACEK MALCZEWSKI

## The Société Nationale des Beaux-Arts

referred to in the course of these notes exhibit from time to time in the galleries of the Secession, with which several of them are definitely associated as members

A. S. L.

### THE SALON OF THE SOCIÉTÉ NATIONALE DES BEAUX-ARTS.

FOR some time past one has watched the growth of an evolution which, should it continue a little longer, must end in robbing the Salons of a great part of their charm. The displays by single artists, or by groups, have now become so numerous that most pictures, before appearing at the Grand Palais, have



LANDSCAPE

(See previous article)

BY S. CZAJKOWSKI

been already seen elsewhere—at the Orientalistes, the Aquarellistes, the Pastellistes, the Peintres Militaires, the Peintres de Paris, or at the Union Artistique or Volney Clubs, not to mention numberless studio displays. So, for those who had attended these shows, there was not much that was new to be gleaned in this Salon of 1907, albeit one could not reproach it with being much worse than its predecessors. Let us now glance at the principal things worth remembering.

In the first place, a room was devoted to Bracquemond, the engraver, and this homage to the great master of his art has my sincere approval. Too often it happens that the Parisian public forgets those who leave it; and it is a good thing that we should thus be reminded of this illustrious survivor of the great race of artistic giants of the 19th century. The collection of Bracquemond's work was very complete, and the proofs exhibited at the Nationale almost all came from the artist's private collection, while some had been lent by collectors. To these were added some of his paintings and decorative art work; thus we had, right in the heart of the Salon,



"MATERNITÉ"

(See previous article)

BY W. SZYMANOWSKI

## The Société Nationale des Beaux-Arts

a little display of highest import and of profound instructiveness.

Decorative painting was represented this year by sundry *morceaux* of much interest. One's attention was attracted straightaway—and it was right that it should be so—to the two great ceilings by Besnard, intended for the cupola of the Petit-Palais. It was somewhat difficult to estimate the value of these two works, which, as seen here, were neither in the place nor in the light in which they will be viewed eventually. Without taking these truths into consideration, one might perhaps be inclined to express less admiration for these works than for other famous productions of this great painter—might find them deficient in brilliancy of colour, and otherwise lacking from the decorative point of view. One of these vast compositions is entitled *La Matière*. It represents the flight through the clouds of a sort of Titan of diabolic aspect, bearing a woman in his arms. In their rush through space the pair leave behind them a

number of fluttering cupids, and altogether the work recalls Tiepolo, without his joyous gaiety. The other panel shows us *La Pensée*, pale and aloof, soaring through the air, while beneath her a human couple encounter Death, in the shape of a woman of cameo-like features. Besnard's work is of too much importance to be judged right off. One must wait to see it in its proper place before venturing, after long and careful study, to pass a final opinion thereon.

The four panels by M. Gaston la Touche, destined to be placed in the Ministry of Agriculture, formed a charming decorative *ensemble*. The artist, recalling the fact that the office of the Ministry was once the mansion of the du Barry, has let his inspiration go back to the 18th century. His panels, *Le Désir de Plaire*, *La Bonté d'âme*, *La Tendresse du Cœur*, and *L'Amour maternel*, while quite modern as to treatment, have yet preserved something of the grace of the *grand siècle*. Apes there are like those of Huet, and



“LA GRAND' MESSE (FINISTÈRE)”

BY LUCIEN SIMON

## The Société Nationale des Beaux-Arts

smiling landscapes of the Boucher sort, with the *égipans*—or satyrs—which La Touche likes to put into his canvases.

M. Francis Auburtin has this year obtained high success with his big picture, *La Forêt et la Mer*, which was one of the "pictures of the season," and deserves close attention. The artist has given to his sea a transparency and a colour which indicate that it has been well pondered and painted *avec amour*. The sky is clear, and the dark forest, descending right to the water's edge, might well be peopled by the nymphs of poesy. Altogether this is decorative in the highest degree.

M. Blanche this year revealed himself an artist of [many parts. In his *Verre de Venise* (reproduced in THE STUDIO, August, 1905, p. 223), and in the picture called *The Shrimp Girl*, I know not whether most to admire the delicate art of their composition or his strong qualities as a painter. His *Portrait of Thomas Hardy* afforded a complete revelation of the care he has taken to express the whole character and personality of his model.

While Cottet is somewhat neglecting Brittany nowadays in order to devote himself to certain interesting experiments in portraiture, his friend Simon, on the other hand, remains true to his old love, his large picture, entitled *La Grande Messe*, being a continuation of those masterly series of Breton life which visitors have admired in former Salons. In his latest work he shows us the village church, with a variegated swarm of choir boys in the foreground; then the dense mass of worshippers, from which stand out clearly the large white coifs of the nuns, alternating with the warm-toned head-gear of the *bigoudines*, the whole forming one of those characteristic compositions wherein M. Simon excels.

From the rough Brittany of Simon we plunge straightaway with M. de la Gandara into the extreme refinement of Parisian life. His portrait of the lady in pink (Signora d'Annunzio) was indicative of all the painter's habitual qualities; in a word it is *spirituel*, delicate and graceful.

In the company of M. Lobre, an assiduous student of Versailles, we were introduced to "interior" painting, which this year had many accomplished followers, few among whom, however, reached the high level of M. Walter Gay, whose exhibits become year by year more refined and more harmonious.

M. Prinnet, who displays a *plein-air* piece full of sunshine and gaiety, had also an interior. Both were quite charming in their essentially different ways.

M. René Ménard, as a true descendant of Poussin, sent a romantic landscape impregnated with the noble sincerity which marks his work. In this same apartment—a sort of *salon carré* in which the various canvases are displayed in such a manner as not to clash against very charming blue-grey hangings—we had a reminiscence of the Trianon period in the portrait of Mlle. Piérat, by Guirand de Scévola, rich-tinted nudes, recalling the Venetian school of M. Caro-Delvaile, and sundry very prosaic and vulgar *bourgeois* by M. Raffaëlli, who, his realism notwithstanding, still remains the able artist we know him to be.

M. Jeannot had four canvases, all charming in their animation and sincerity. The girl swinging in a rocking-chair was particularly delightful.

The sea-pieces by M. Chevalier and the Dutch landscapes by MM. Waidmann and Stengel formed notes of colour, instinct with variety and attraction.



"THE SHRIMP GIRL"

BY J. E. BLANCHE





"LE JUGEMENT DE PARIS"  
BY E. R. MÉNARD



“LE DÉSIR DE PLAIRE”  
BY GASTON LA TOUCHE



“LE BONTÉ D'ÂME.” BY  
GASTON LA TOUCHE



“LA TENDRESSE DU CŒUR”  
BY GASTON LA TOUCHE



"L'AMOUR MATERNEL"  
BY GASTON LA TOUCHE



“LA FORÊT ET LA MER”

BY J. F. AUBURTIN

M. Dinet still shines as an Orientalist, and he has succeeded in rendering all the warm splendour of Africa in the draperies that cover the body of *Zeinel the Enchantress*. Beside this picture he exhibited a little portrait—at once very amusing and very life-like—of M. Chéramy, the well known Parisian collector. A fine and sober portrait was that of M. Beurdeley, another celebrated collector, by Zorn. M. Briand, the Minister of Public Instruction, was less felicitously handled by M. A. Berthon; but M. Maurice Donnay, the dramatist, formed the subject of an excellent portrait by Abel Faivre. MM. Raymond, Woog, Picard, Ablett and Lavery also displayed portraits of men calculated to inspire the hope that by next year they may have turned their attention to feminine grace.

M. Friant, with the exactitude and the restraint which characterise his work, executed an almost too striking likeness of M. Dubufe.

M. Carolus Duran, the Villa Medicis giving him plenty of leisure, continues to send from Rome portraits which add nothing new or personal to a popular style of art in which he has few superiors.

Mr. Harold Speed proved to us by his portrait of

King Edward VII. that “official” painting has the same qualities and presents the same dangers all the world over. M. Dagnan-Bouveret is losing his rare gifts and becoming a painter of popular subjects, which can never appeal to those who love personality and study. It was sad to see his fine talent evaporating in this way.

The posthumous exhibition of some of Fritz Thaulow’s canvases intensified one’s sorrow at his demise, for they showed the artist in the plenitude of his powers. Happily there are some still living, but deserving of remembrance when they shall be gone, to console us for those we have already lost; among them are M. Lhermitte, always worthy of himself, and M. René Billotte, who, as the interpreter of the tender, melancholy hours he holds so dear, continues to hold close communion with nature.

M. Zakarian, whose *genre* work never fails to remind one of the masters in that department of art, exhibited five superlatively good examples of still-life. Mme. Madeleine Lemaire renounced her flower paintings in favour of a *genre* subject, *Le Bain de Chloris*, in which all her deli-

## Talashkino

cacy of palette was once more apparent. Among the legion of flower painters one has to make mention of M. Karbowsky, who has a very personal gift; of Mme. Devolvé, who continues to preserve the dignity of her name; and of M. Dumont, whose six exhibits were, without exception, very beautiful. Now that our great Fantin is no more, M. Dumont is certainly the best painter of flowers of our modern French school.

H. F.

### TALASHKINO: PRINCESS TENISHEF'S SCHOOL OF RUSSIAN APPLIED ART.

BY C. DE DANILOVICZ.

Two great currents, the expressions of the intimate opinions of two camps, at the present time divide artistic Russia. On the one hand is the gravitation of a group of artists towards the most extreme Occidental tendencies, towards the newest altars of French art; on the other, is a revival of the tradition whose treasures the centuries have accumulated in old Russia, the Rous of the period anterior to Peter the Great. This latter current, more profound and more original, since it is not merely imitative and does not seek to introduce into Russian art elements foreign to the Russian soul, is incontestably more interesting by reason of its power.

Russian plastic art, as well as Russian music, to-day turns towards the past, so rich in wonders, and on which the very soul of the people sets a most individual and original seal. Russian music before Glinka was Italian. It was only from the time that composers found their inspiration in the melodies of the people that it acquired its national and artistic value. The same with the sculptural and pictorial arts. Towards the end of the nineteenth century, thanks to ethnographical re-

searches, thanks to the birth of a truly nationalist artistic movement, exempt, however, from all trace of Chauvinism, this great truth was, so to speak, discovered that Russia has not the least need to seek her inspiration from the Occident, that without going to make her pious genuflexions in the little sanctuaries of the Salon d'Automne or the Independants, she can live and prosper artistically on the immense capital bequeathed her by past centuries.

The simultaneous birth of Russian operas, reflecting the musical soul of the people, gave to artists a vast field of action in decoration and



CARVED DOOR AND FRAME FOR TALASHKINO THEATRE  
DESIGNED BY S. MALÍUTIN

## Talashkino



ARM CHAIR DESIGNED BY PRINCESS M. K. TENISHEF

staging, which they realised magically in a splendid evocation of the life of olden times. Here decorative ornamentation revived and developed. Vasnetzof, Mmes. Polenof and Yakoutchikof were the first zealous pioneers in this. Mme. Mamontof,

who took a warm interest in art, founded in the village of Abramtzevo, in the Moscow Government, ateliers where the artists, drawing their inspiration from the old subjects of everyday use, created an art which could pretend to a Russian style, if style there is. The distinction of this movement lies in its sincerity, its originality and the individual vigour, if we may so call it, of each object.

Little by little the importance of Mme. Mamontof's ateliers declined, in consequence of the death of the artists who were the first to promote this movement, and it was then that

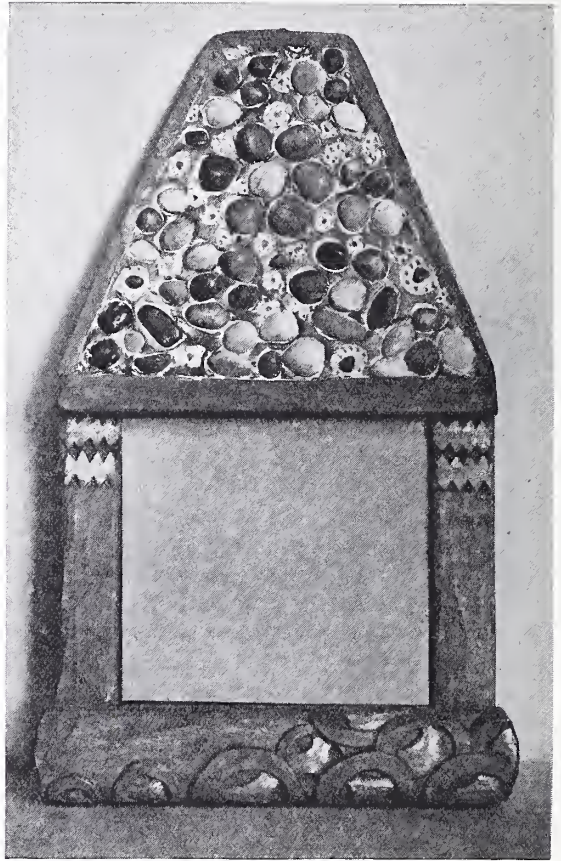

WOODEN FRAME ORNAMENTED WITH STONES  
DESIGNED BY A. ZINOVIEF

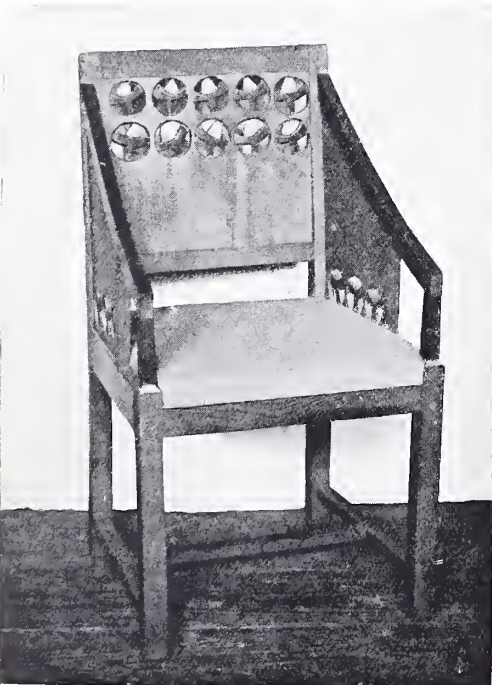

ARM CHAIR DESIGNED BY A. ZINOVIEF

Princess Marie Tenishef, widening the limits of a school created by the Princess Sviatopolk-Tchetvertynska at Talashkino, in the Government of Smolensk, founded the veritable Russian applied art. The Minister of Public Instruction has interested himself in this school, and has assured it the protection of the Government.

Princess Tenishef, herself a remarkable artist, at once gathered round her the best among those to whom the regeneration of Russian art was dear.



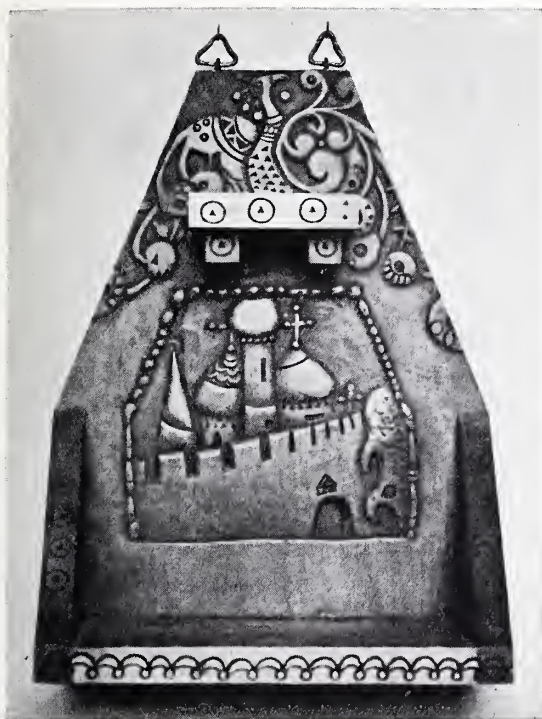

“POLOTCHKA” OR WALL-BRACKET  
DESIGNED BY A. ZINOVIEF

Serge Malútin took charge of the studio of sculpture: this extraordinary artist seems, like Surikoff, to pursue, in the midst of our civilisation, some fantastic dream of the misty ages of heroes and legends. His influence on the *début* of the art of Talashkino was very great. He powerfully sounded the forgotten note of ancient epics with their marvellous stories of the “Sun Bird” (*žar-ptitza*), the flaming bird of the old beliefs, symbol of all the epic past of Old Russia. Then Zinovief and Bolotof placed their talent at the service of the Princess Tenishef, who herself designed a number of objects in which the decoration, drawn from subjects in the vegetable world, is richly developed.

Designs for wood-carving for furniture, caskets, small objects of everyday use, embroideries of rare beauty, stuffs of blended tones, ceramics, pottery—in short, everything connected with domestic life, left Princess Tenishef’s hands bearing the seal of originality. She devotes herself, moreover, to a purely personal art, which she cultivates with an incontestable mas-

tery—the art of enamelling. Her *champs-levés* with their dull tones of an ideal purity, composed in the style so dear to her, arouse a general admiration, and her case at the Salon of the Société Nationale des Beaux-Arts at Paris was one of the most remarked. Her works stood out among others of a more commonplace beauty by reason of their richness and subtlety of tone, and the originality of composition, which seems almost spontaneous in its individual power.

The objection has often been raised that ornamentation, drawn in part from the actual sources of peasant art, and in part from the rare remains of the ornamental art of past centuries,

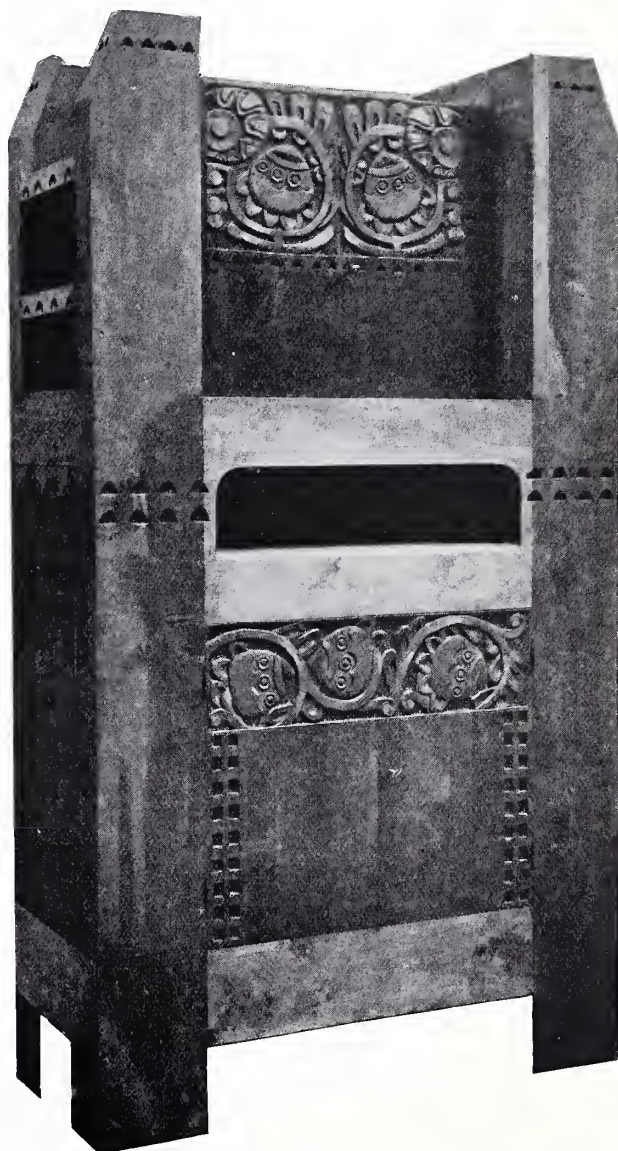

BUFFET CUPBOARD

DESIGNED BY V. BEKETOFF

## Talashkino



WALL CUPBOARD

DESIGNED BY A. ZINOVIE

gave an almost barbaric note to the productions of the Talashkino ateliers. Yes, if you will, there is a stammering essay at speech, but it is "a stammering in which the spelled-out sentences have the spontaneity and frankness of those melodies, of those poems of the people, in which the soul of the race perpetuates itself."

By degrees, happy modifications and wider ideas introduced more fantasy and freedom into the decoration, which ceasing to be a slavish reproduction of the models of former ages, had free scope, yielding to the improvisation of artists whose souls drank from the springs of contemporary art, who could revive and apply to the objects of our everyday life the themes bequeathed by the past. From this time the new art appeared, a Phoenix springing from the ashes of legend, but like Antæus, ever touching its native soil to recover its strength and beauty. It was, therefore, according to popular tradition that the artists who have charge of the ateliers at Talashkino created the works of which the reproductions accompanying this article represent a small selection.

Ewers, armchairs, tables, sump-

the decoration to the object decorated—a truly difficult task, rarely undertaken and still more rarely successful in the mechanical production of to-day.

Talashkino also possesses its own theatre, where representations of some very interesting dramatic works are given, and where a complete orchestra

tuously embroidered tablecloths, curtains, everything that emanates from Talashkino has the charm of being made by hand, and everything is stamped with an originality of its own, in which, however, there is nothing uniform, for the Princess Tenishef never sends out two identical objects from her ateliers. The powerfulness of the colouring in most of these objects is such as to elicit our genuine admiration, as also is the interlacing of the line, which nevertheless unrolls itself in harmonious curves; we must bow before the science of composition which can so finely unite



CARVED AND PAINTED CASKET

DESIGNED BY A. ZINOVIEF

## Talashkino



"POLOTCHKA" OR WALL-BRACKET

DESIGNED BY A. ZINOVIEF

fume of forgotten legends, these works so wonderfully rich in tone and capricious in contour, in which stone, metal and wood are united for the final effect.

And from the various objects, fashioned after the drawings of the rude hands of the little Talashkino peasants, emanates a force, mysterious and powerful, which benumbed by the winter sleep of centuries now wakes to the Spring of a new era, bringing to us a fresh note in which vibrates the highest beauty—the ingenious and sincere beauty of an art which

play upon most tastefully decorated *balalaikas*. Both in the architecture and decoration of this theatre the same concern for artistic refinement is manifest as in other products of the establishments.

The achievements of the Talashkino ateliers cannot be compared with similar works of the Occident. Their originality is so strong, so surprising, that, accustomed as we are to certain æsthetic postulates, to certain formulæ of criticism, we feel that in order to judge them we require a special sense; we feel that it is impossible to measure this art by the same standard as that which we apply to the art of the Occident. It is only after studying them thoroughly, after becoming familiar with them, that we can form an exact opinion of and appreciate these works about which hangs the per-

appears before our ancient civilization in all its shining youth—centuries old. C. DE DANILOVICZ.

(Some further illustrations of Talashkino work will be given in the next number of THE STUDIO.)

Messrs. Lee-Hankey, G. Moira, A. Withers and A. Fisher have been awarded medals at the Barcelona Exhibition, and Mr. Brangwyn a Special Diploma. Several English works have been acquired by the Government.

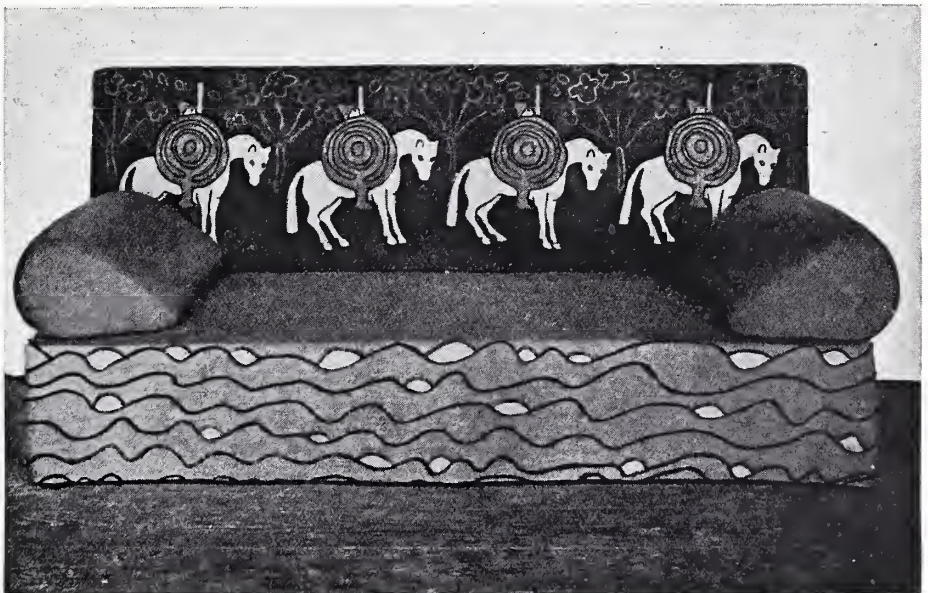

SETTEE

DESIGNED BY N. ROBRICH

STUDIO-TALK

(From our Own Correspondents)

LONDON.—The interest of the New English Art Club was this season diminished by the absence of works from Mr. Conder and Mr. Orpen. The student element was, too, perhaps, a little in evidence. Mr. Sargent contributed virility which in other works we seemed to miss. The most interesting contributions from outside were made by Messrs. Alexander Jamieson, W. Shackleton, F. H. S. Shepherd, A. Rothenstein, S. Teed, H. S. F. Gore, Mrs. McEvoy and Miss Ethel Walker. Within the list of membership, *The Beaver Hat* and the landscape *The Bend of the River* participated of Mr. Wilson Steer's best manner; Mr. W. Rothenstein was to be found still concentrating his earnest brush on the interpretation of Jewish rite with mingled sentiment of its simplicity and solemnity. In *The Strolling Players*, Mr. Tonk's subject seemed a problematic one chosen with a view to the treatment of certain effects of light, the problems of which seemed to lose their interest from the fact that they were solved upon a subject which did not gain from such conscientiously realistic treatment. Mr. W. W. Russell's delicately-coloured and natural *A Winter Morning* and his other subjects represented him well. In the picture *The Mill*, rather than in his portrait, Professor Brown gave his best. Mr. C. J. Holmes's *On the Grand Junction Canal* was a canvas of much beauty, and there was an important work exhibited by Mr. Walter Sickert. One corner of the New English Art Club Galleries is always greatly attractive. It is that in which the water-colours of Mr. Rich, and the pencil drawings of Mr. Muirhead Bone, and Mr. John are to be found.

Members of the Royal Society of British Artists will be interested in the new badge of office designed by Mr. Frampton, R.A., for use by the President of the Society on ceremonial occasions. The badge itself is of silver, while the band is of dark blue silk relieved by silver mounts.

Miss Edith Adie has already been introduced to readers of THE STUDIO as a painter of garden pictures, and our coloured supplement furnishes another example of her work in this direction. Miss Adie has worked a great deal in the South of Europe, and the interesting collection of pictures of *Gardens and Italian Rock Villages*, which she has just been showing at the Fine Art Society's

Galleries, was largely the outcome of her sojourn there.

Mr. Van Wisselingh has been holding an exhibition of Mr. Vilhelm Hammershøi, whose interior pieces have attracted so much attention at the Guildhall. But for a certain monotony of vision there seems no limit along his chosen lines to Mr. Hammershøi's power. We hope later on to return to the work of this unusually interesting painter.

The Rowley Gallery, Silver Street, contained last month a number of interesting water-colours by Mr. Frank Brangwyn, and Mr. Alfred East; and there were also examples of Mr. A. W. Rich's distinguished art, some work by Mr. Bertam Priestman, Mr. Sydney Lee, and Mr. H. M. Livens, the latter an artist with the power to communicate his conviction of the beauty of restrained grey colour, but whose want of courage in that conviction leads him to touch his work up with meretricious looking patches of pure colour, thus marring its otherwise naturalistic charm.

Genre painting, of a kind prevalent more than



BADGE OF OFFICE FOR PRESIDENT OF ROYAL SOCIETY OF BRITISH ARTISTS  
DESIGNED BY G. FRAMPTON, R.A.



"HERBACEOUS BORDER AT KNOLE, KENT," BY EDITH HELENA ADIE.



## Studio-Talk

a generation ago, is revived in the art of Mr. Ambrose McEvoy, who exhibited last month at the Carfax Gallery. Considerable charm as a colourist is in this artist's possession, but he sometimes misses the grace of human gesture so necessary to his art. In certain moods, however, he is not to be rivalled in the line he has chosen. As a landscape painter he has much power, if a vision which is less clearly his own.

At the Alpine Club in June Mr. Sholto Johnstone Douglas exhibited a collection of his portraits. The artist is apparently a prey to indecision in the matter of style, many influences, from Romsey to Wilson Steer, being apparent. "*Marquise*," *Mrs. Russell Bryde*, *Study for a Portrait Group*, and the *Lady Kinross*, however, were portraits of some distinction.

The pictures by French and Dutch masters of the nineteenth century at Messrs. Obach and Co.'s, from which we reproduce the works by Corot,

Rousseau, Monticelli, and Daubigny, on this and the following pages, showed those masters, together with the Marises, Millet, Diaz, Harpignies, Courbet, and others of the school at their best. In *The Ville d'Avray—Morning* and *The Quiet River* we had all that is most intimate of the mood of Corot. The large *St. Sebastian* by that painter, Daubigny's *Le Verger* and Millet's *Le Traitè d'Union*, were notable pictures, as was a canvas by Monticelli, painted at the time when his art had budded into a strangely beautiful flower before the efflorescence of his last period. His master, Diaz, was well represented here, and Fantin by an early work, the head of a peasant, as well as by flower pieces. M. Harpignies, now long past his 80th year, was represented by a recent canvas betraying no diminution in power.

Mr. D. Y. Cameron's new Belgian set of etchings were lately exhibited by Messrs. James Connell and Sons, together with a collection of other plates by the artist. Mr. Cameron's art with

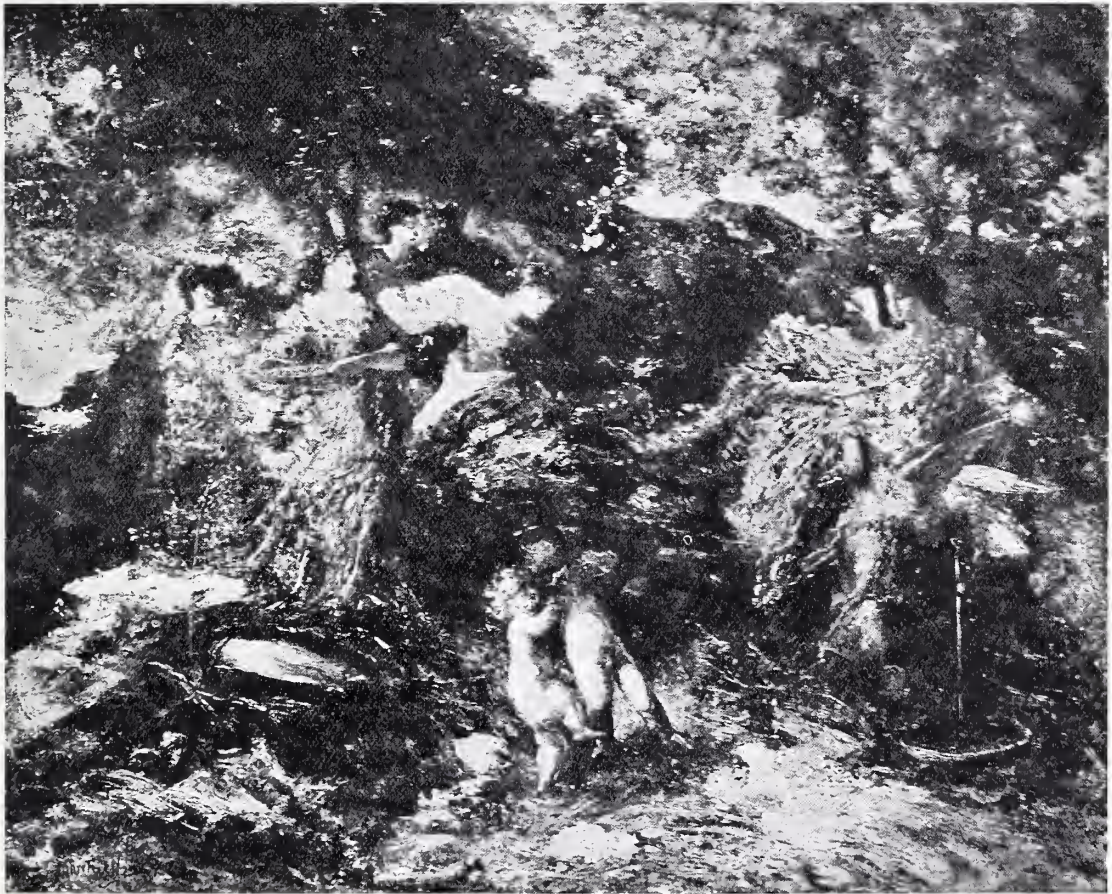

"FÊTE CHAMPÊTRE"

(Exhibited at Messrs. Obach's Gallery)

BY A. MONTICELLI

## Studio-Talk

time becomes more romantic and subjective. His accuracy in architectural draughtsmanship is unaffected, but as Mr. Wedmore so admirably emphasised in his introduction to the catalogue, it is architecture charged with human association.

At the Leicester Galleries Mr. G. Denholm Armour has been exhibiting some sporting pictures, and the original drawings of subjects which have appeared in *Punch*. He proves himself an oil-painter of achievement, his work being very far removed from that order of coloured illustration which so often is all that denotes the transference of a black-and-white artist's energies into the wider field. In the same galleries a collection of water-colours by Mr. John R. Reid were to be seen, and with other work of interest two oil-paintings by Mr. Charles Conder, showing the master of colour at his best.

The exhibition of the Pastel Society as usual provided the study of many methods. A feature of the exhibition was a series of portrait drawings by Mr. Sargent, and it was pleasant to find the art of the late H. B. Bra-bazon still represented. There was a portrait study by Mancini (lent to the exhibition) drawn with some impulsiveness, but with a delightfully nervous and sensitive touch. Near to this picture Mr. W. G. von Glehn exhibited in *Lady Herbert Scott* a portrait of charm and finish, showing mastery of his difficult material. Miss A. Airy, a new member, in *The Silk Gaberdine* proved that she understands the particular charms of her medium to an exceptional degree. Mr. J. R. K. Duff has never been more interesting than in his pictures *The Farnyard*

and *The Hollow*. A finely executed little work was Mr. H. S. Tuke's *Blue Bells*, and in *Rubella* Mr. Bernard Partridge's work was always graceful and accomplished. There was fascination in *A Head* by Mr. Harrington Mann. Mr. Melton Fisher, to whom pastel has always been a sympathetic medium, was represented best by the two admirable portraits *A. Lys Baldry, Esq.*, and *Miss Violet Hunt*; other portrait work of much interest were Mr. Harold Speed's drawings, Mrs. J. von Glehn's *Mr. Henry James*, Lady Sassoon's *Dr. Segond*, and Miss Flora Lion's *Julius Friedberger, Esq.* Very fine in draughtsmanship were some nude studies by Mr. Cecil Rea; there were to be noticed also the works of Mr. A. S. Hartrick and Mr. J. Pennell, the delicate—if sometimes too pretty—studies by Mr. Lewis Baumer, Mrs. Borough Johnson's *Feeding*



“SUMMER IN THE FOREST”

(Exhibited at Messrs. Obach's Gallery)

BY TH. ROUSSEAU



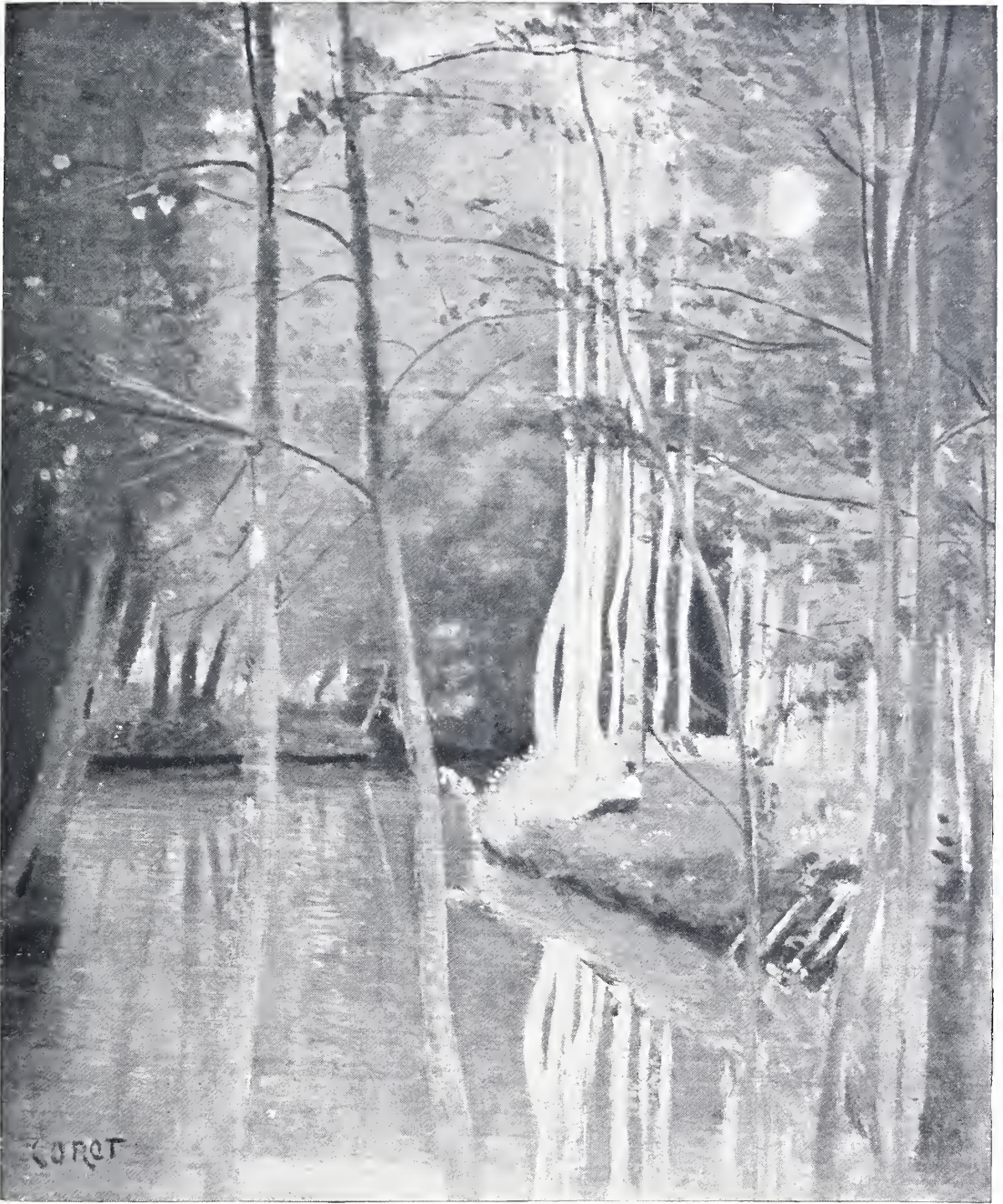

"THE QUIET RIVER." BY J. B. C. COROT.  
*(Exhibited at Messrs. Obach's Gallery.)*





“LE VERGER.” BY  
C. F. DAUBIGNY

*(Exhibited at Messrs. Obach's Gallery)*

## Studio-Talk

Time, Miss L. Pelling-Hall's *Cornish Cottages*, Mr. H. Marchman's *Chrysanthemums*, Mrs. Isobelle Dods-Withers' *Autumn at Les Andelys*, Mr. G. P. Jacomb-Hood's study *The Duke of Plaza Toros*, Mr. G. H. Workman's the *Gondoliers*, Mr. Carton Moore Park's *Motherless*, and work by Messrs. A. L. Withers, H. M. Livens, S. M. Wiens, Talbot Hughes, Simon Bussy, W. L. Bruckman, A. Lévy Dhurmer, and Miss Sterndale Bennett.

At the Ryder Gallery last month some exceptionally interesting miniatures were shown by Mrs. Gertrude Massey. The miniature of *H.M. Queen Alexandra* was a model of refined and skilful treatment, alike in the delicate colour scheme, the transparency of the shadows, and the skilful suppression of detail in dress. *H.R.H. Prince Olaf of Norway*, *Isabel*, daughter of Col. Hutcheson Poë, C.B., and *Priscilla*, daughter of Lady Alice Reyntiens were also miniatures of great success. Another phase of Mrs. Massey's art is portraiture of pet animals, and in this direction scarcely any

of them could be happier than the picture of H.M. The King's dog *Punch*. Among water-colours shown by Mr. H. S. Massey, *Marble Arch*, *The Shot Tower*, and *Park Lane*, were very successful pictures, but Mr. Massey's hand does not yet quite instinctively follow the habit of vision which apparently he is cultivating.

An exhibition of water-colours by Mr. Onorato Carlandi, held at the Fine Art Society, showed an artist working with much sincerity and simplicity of style at many different subjects. The *Ponte S. Giovanni*, *In the Campagna—Saxa Rubra*, *Boats at Ripagrande*, and *Near the Farnesina*, were the most interesting of these.

VIENNA.—At the Hagenbund Spring Exhibition one of the centres of attraction was the series of grotesque busts in alabaster by Franz Xavier Messerschmidt, a sculptor who died more than a century ago. He was a native of Wurtemberg, and studied at the

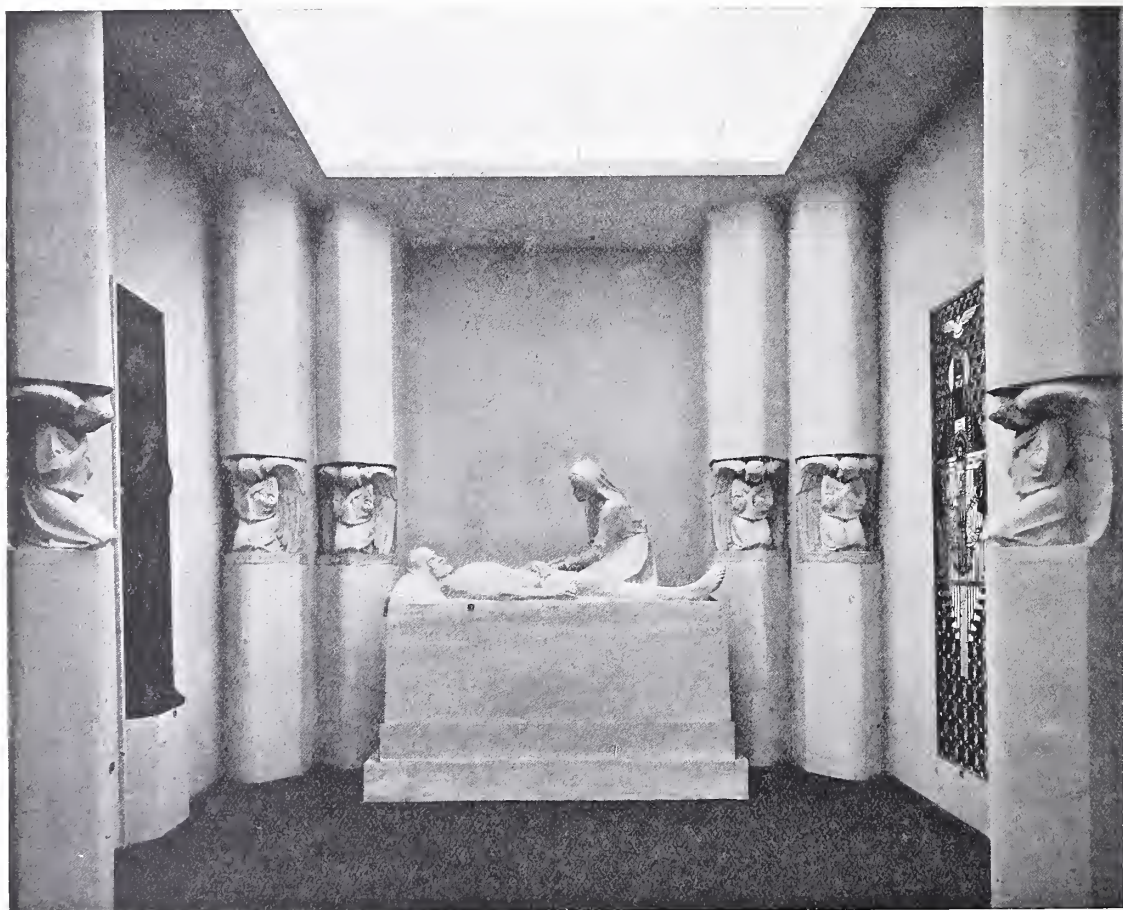

HAGENBUND SPRING EXHIBITION, VIENNA

MAUSOLEUM BY JOSEF HEU

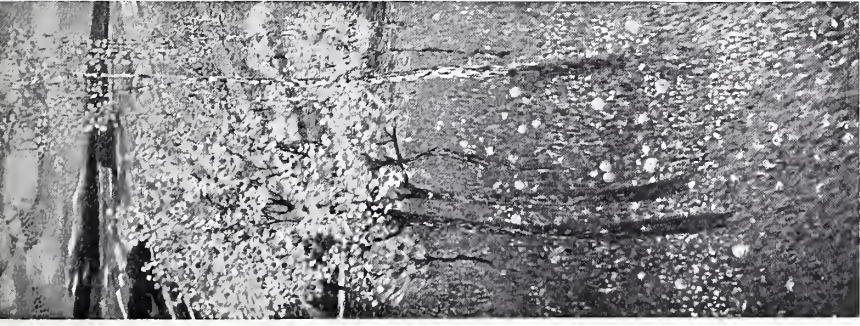
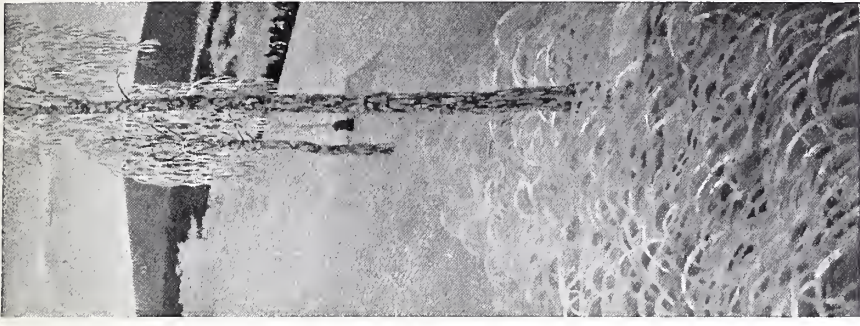

"THE SEASONS": A SET OF  
FOUR PANELS BY HUGO BAAR

(Hagenbund, Vienna)

## Studio-Talk

Vienna Academy and in Rome. After his return he became a teacher at the Academy, but was pensioned soon after his appointment on account of his eccentricities, whereupon he retired to Pressburg, where he died in 1783 at the age of fifty-one. He was a man of peculiar temperament, and modelled these busts simply for his own pleasure, as he said. A great patron and lover of art, Duke Albrecht of Sachsen-Tetschen, son-in-law of the Empress Maria Theresa and founder of the "Albertina" Museum, Vienna, offered to buy them for 1,800 florins, a large sum in those days, but even this did not move the sculptor, who intended, he said, "to throw them into the Danube when he felt death approaching." "Meister" Messerschmidt intended doing a hundred of these busts, but when the Duke visited him had only got as far as the sixtieth. After many vicissitudes, what remained of those he did were housed in the Staatsgewerbschule, Vienna, and here Josef Urban, the architect, unearthed them. They were arranged on either side of the entrance to the majolica room, which was decorated by Herr Urban, as were, indeed, the other rooms, except the Black and White one, for which Alfred Keller, a rising young architect, was responsible.

In the majolica "Saal" was some beautiful ceramic work by Michael Powolny and Bertold Löffler, showing variety of form and true feeling for style. Josef Heu, a talented young sculptor, exhibited the marble bust of a young Count, a dignified performance revealing that love for his work which we associate with his name. Another notable accomplishment of his was to be seen in a Mausoleum, which occupied a space by itself and was infinitely expressive of its purpose. Heinrich Karl Scholz showed much talent in his marble bust of Count Clam Galla. Franz Barwig exhibited some excellent figures in ebony of Sunda panthers, cats, and other animals, and Emmerich Simay some fine bronze studies of monkeys, in which the intimate relations and habits of monkey life are portrayed. Simay also contributed some excellent pen drawings showing conspicuous ability and judgment. Of Count Herbert Schaffgotsch's wood intarsias much could be said. They show beauty of form and conception, fine artistic feeling, and thorough knowledge of an art which has found but few followers.

---

Among the portrait painters Ludwig Ferdinand Graf and Ludwig Kuba were to the fore. The former this time only exhibited pictures of chil-



"A WINTER EVENING"

*Hagenbund, Vienna)*

BY PAUL ROESS

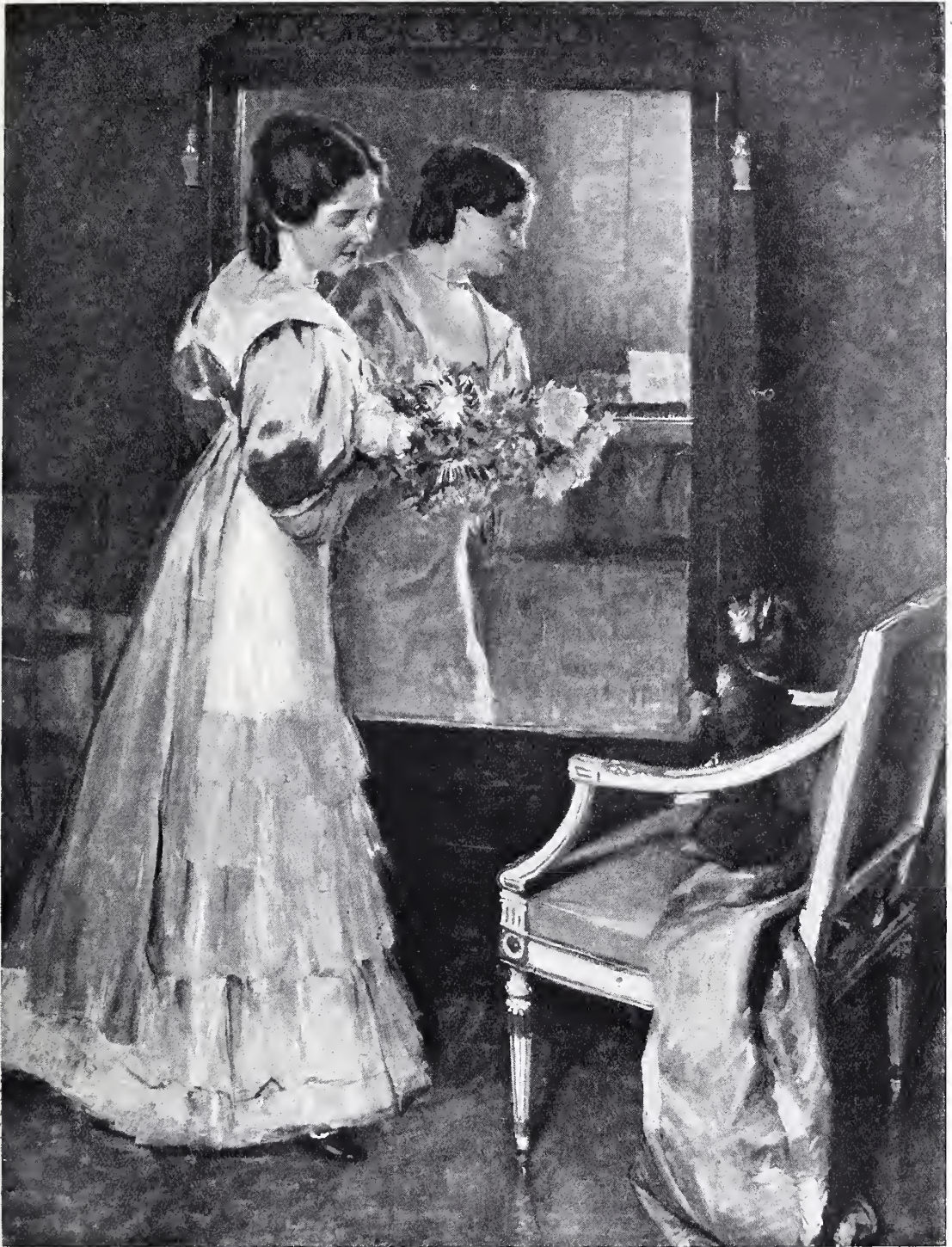

*(Künstlergenossenschaft, Vienna)*

PORTRAIT OF FRL. HOFTEUFEL  
IN "THE IDEAL HUSBAND." BY  
JOHN QUINCEY ADAMS

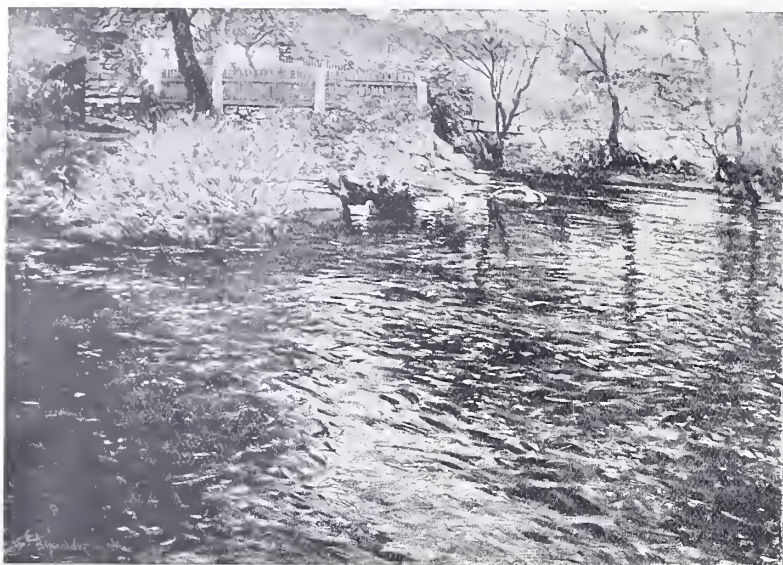

TEMPERA PAINTING: "THE MEADOW BROOK"  
(Künstlergenossenschaft, Vienna)

BY ED. AMESEDER

dren, in which he excels. Ludwig Kuba's portraits in pastel show much force and energy, and his oil portrait of his little son was also capital. Alexander D. Goltz was very happy in his portrait of Fräulein Mary Mell as Fanny Willoughby in "Quality Street." Gotthard Kuehl (Dresden) in his portrait of himself and *Mother and Daughter*, both in oils, showed excellent examples of his methods. Walter Hampel, as usual, gave ample opportunity to judge of his varied powers in portrait painting, and he also exhibited a number of sketches in tempera and water-colours which were highly pleasing. A new phase of his art was shown in some miniature portraits mounted as articles of jewellery.

Turning to the landscape paintings, Hugo Baar's four panels, *The Seasons*, call for special notice, on account of the great delicacy of feeling and symmetry of arrangement shown. August Roth, Henryk Uziemblo, Kasimir Sichulski, Franz Simon, Rudolph Junk, and Paul Röss exhibited good examples of their work. The last-mentioned sent but one picture, *A Winter Evening*, admirable for its rendering of atmosphere and the motion of the trees.

Rudolf Junk, besides being responsible for the decoration of the catalogue, contributed several woodcuts, some in colours; Alexander Wilke pen-drawings, Rudolf Konopa a number of monotypes of scenes in Brittany, some of them of great beauty. Richard Lux's coloured etchings testify to a high degree of skill and artistic feeling; Max Svabinsky's portrait of a gentleman was an excellent example in his well-known manner of pen drawing combined with water-colour drawing. Leopold Forstner deserves a word of praise for his stained-glass windows (one

of which forms part of the mausoleum above referred to), as does Berthold Löffler for his mural decorations. The Prag - Rudniker Korbwaren



"AT KIRCHBERG ON THE DAYST"

BY EDUARD ZETSCHKE  
(Künstlergenossenschaft, Vienna)





PORTRAIT

BY VICTOR SCHARF

Fabrication, Vienna, contributed some very excellent examples of wicker-work furniture, designed by Wilhelm Schmidt.

At the spring exhibition at the Künstlerhaus portraits, as usual, played an important rôle. The latest portrait of the Emperor Francis Joseph, painted by Leopold Horovitz, attracted much attention, and certainly it is a fine work. It was painted three years ago, and the Emperor gave nine sittings for it. The original was presented to Prince von Bülow, while the work shown at the Künstlerhaus was, first of all, the sketch, but the artist has since then made it into a finished work, and it is one of the finest portraits of the Emperor existing. His portrait of Ritter Paul von Schoeller is an excellent work, especially as regards the painting of the hands and the pose. Horovitz's portrait of his youngest daughter is a fine example of girl portraiture. She is depicted seated at a table, with her arms resting on a large volume, and the oval face, with its intellectual features,

is painted with admirable feeling; and excellent, too, is the rendering of the old Polish table-cover, with its mellow golden tones. László's contribution consisted of two portraits of ladies, *Countess Jean de Castellane* and the artist's mother, the latter a small square picture with a dark background, which serves to bring the features of the old lady into prominence. Professor Heinrich von Angeli sent but one picture, a young girl in profile.

John Quincey Adams' portrait of *Fräulein Hofteufel*, a favourite actress, as Miss Chiltern in

Oscar Wilde's "Ideal Husband" (p. 151) found many warm admirers. The introduction of the mirror for the purpose of showing another aspect of the face is, of course, not a new idea; but the picture as a whole is excellently composed, and particularly felicitous is the contrast of the actress's dark Brunette beauty with the yellow and white of her frock. The portrait of *Frau Drill-Orridge*, the singer, is a striking study in black-and-white by the same artist; except for the



"THE POND IN THE WOOD"

BY HUGO DARNAUT

old Gobelin tapestry background, the pose and general arrangement showed the influence of the old English masters of the eighteenth century, especially Gainsborough.

Arthur von Ferraris's two portraits were good examples of this artist's methods. Victor Scharf's profile portrait of a gentleman sitting in an old armchair is a dignified work, the expressive and characteristic features being delineated with that intimacy which is peculiar to this artist. His portrait of a young lady in a sealskin jacket, too, was excellent as a study in browns. W. V. Krausz's portrait of a lady, *Frau K.*, showed a marked advance on his earlier work. As a portrait it is extremely good, and the delicate sheen of the yellow and blue shot silk gown is admirably rendered. Paul Joanowitch, Hans Larwin, Karl F. Gsur, and Edward Veith were all well represented, as were Heinrich Rauchinger and Kasimir Pochwalski.

There were many good landscapes — Hans Ranzoni, M. Suppantšitsch, Eduard Kasparides, Josef Jungwirth, Karl O' Lynch of Town, Heinrich Tomec, Ferdinand Brunner and other well-known artists being represented by characteristic works. Hugo Darnaut's *Pond in the Wood* is one of his favourite motives: a pond with tall reeds, blown hither and thither by the winds, in the background tall trees through which the light is thrown and reflected on the stagnant water. Eduard Zetsche exhibited some of those charming scenes of country life in Austrian villages, with which he has made himself so intimately acquainted. Eduard Ameseder showed a decorative painting of a piece of water with ducks swimming near the land. Nikolaus Schattenstein's large picture *Römische Lieder* gained many admirers. Nine persons, life-sized, are shown sitting on the grass, playing the guitar and



PORTRAIT OF A LADY

BY W. VICTOR KRAUSZ

making love; behind are trees. The colouring, as becomes the subject, is very vivid, the attitudes of the figures easy and graceful. This artist also contributed some good portraits. Otto Henschel's *Before the Toilette* testified to the great advance which this young artist has made of late, both in colouring and composition; he is on the right path, and will find what he is seeking. Rudolf Quittner's *Die Reise* is a daring work. It is a triptych, the centre panel of which shows an interior with a medley of travelling impedimenta strewn about pell-mell, while the left-hand panel gives a glimpse of the train which apparently is carrying the travellers to their destination, represented by the landscape shown in the right-hand panel. Every possible colour is given, yet each seems to tone well with the rest. Isidor Kaufmann, the well-known painter of Jewish types, only sent one picture, *Jom Kippur (The Day of Atonement)*; a picture representing a young bride,

## Studio-Talk

veiled according to the tenets of her religion. Seldom has an artist given us a more striking and intimate delineation of those characteristics of his race, which he so loves to depict, than in this work. Carl Fahringer's studies of animals are excellent. Among the lady artists Tina Blau contributed two pictures, one of them an attractive landscape, *Early Spring*, and Frau Wiesinger-Florian pictures of villages and of gardens filled with luxuriant and glorious coloured flowers.

The plastic exhibits were as usual very numerous. Hella Unger's plaquettes and Melanie von Horset-

sky's bust of a gentleman show much merit. Franz Seifert's *Schmerz* is a worthy work; Friedrich Gornik's animals, especially the group of tigers, deserve warm recognition; Stephan Schwarz contributed some excellent plaquettes and medals; Anselm Zinsler, a nude figure of a woman lying at full length. This was one of the most important works and showed great knowledge of anatomy and power of treatment. Hans Schaefer's medals are always praiseworthy; and Johannes Benk's portraits of children (marble) impressed one by their insight into child life.

Many foreign artists exhibited at the Künstlerhaus this year, among them Alfred East, Arnesby Brown (who was awarded a gold medal) and Alfred Parsons, whose works found much appreciation. There were also a number of French exhibits.

A. S. L.



PORTRAIT OF FRAU DRILL-ORRIDGE

BY JOHN QUINCEY ADAMS

**B**ERLIN.—The Great Berlin Art Exhibition offers a pleasing show this year. There are not as in the Paris Salons magnetising paintings of monumental dimensions, nor daring experiments of technical inventiveness. There are not as in the big London exhibitions pictures of extreme refinement and peculiar grace. As we wander through the suite of some fifty rooms, most tastefully fitted up on a neutral colour-scheme by the architect Möhring and the painter Looschen, we miss artists of originality and power, yet our total impression is one of true sympathy with sane and serious endeavour. The waves of uproar have beaten somewhat too violently against æsthetic convictions in Germany, and we are thankful for a compromising spirit resulting from the assimilation of useful lessons. There is no prominent nude and no striking subject-picture if we except Rudolf Thienhaus' voluminous *Communion*, with its sober colouring and convincing characterisation, or Heichert's *Salvation Army Prayer Meeting*, with its psychic light effects. Following the

## Studio-Talk



MEDALLION BY HANS SCHAEFER  
(See Vienna Studio-Talk)

example of Dresden, a hall of honour is devoted to portraiture new and old, and excellent works of Kampf, Hildebrand, Thoma, Steinhausen, Herkomer, Sargent, Besnard, Knaus, Koner, Gussow, Meyn, Röbbcke, Vogel, Melchers, László, Schulte im Hofe, and Bacher, maintain their significance beside those of Van Dyck, Raeburn, Reynolds and Courbet.

Landscape shows a considerable group of gifted interpreters. We are always glad to meet Bracht, Frenzel, Kallmorgen, Boehme, K. Lessing, Douzette, Hoffmann-Fallersleben, Urban, Hamacher, R. Kaiser, and some younger men as Hartig, Kaiser-Eichberg, Wendel, Licht, Sandrock, Hans von Petersen and Thiem are winning favour generally. Still life is this year at its best and *genre* indifferent. Early Florentine renaissance celebrates a resurrection in the paintings of Friedrich Stahl. Imagination and originality seem to have only inspired some artists in black-and-white and some medallists. German sculpture shows vitality and ability.



"THE MOUNTAIN STREAM"

BY HANS VON PETERSEN

*Studio-Talk*



“NOON”

BY LEONHARD SANDROCK



“WINTER EVENING”

BY FRIEDRICH KALLMORGEN

Some interesting single exhibits point to marked talent in various fields. Fritz Burger, the portrait-painter, convinces us of his gift for seeing the inward characteristics of his sitters. Professor Arthur Kampf, the newly-elected President of the Academy of Arts, whose appointment meets with unanimous approval, proves his realistic power, his taste and reliable draughtsmanship in historical subjects and portraiture. Carl Langhammer, the landscape-painter, develops more and more his art of rendering wide stretches of country, cloud-effects, and the phenomena



"SUNDAY REST"

BY HANS LOOSCHEN

of light and air. The sculptor Schauss, with his

tendency to gracefulness, and the sculptor Bossard, the thinker, with his straight, unpliant lines, represent two extremes of artistic bent. Munich is as well represented by the Luitpold Group and the Künstler-Genossenschaft as are Düsseldorf, Hamburg and Dresden. The Swedish and Danish sections are particularly interesting.



"ON THE BALCONY"

BY WILHELM MÜLLER-SCHOENEFELD

In the section of applied art, the rooms of Professor Bruno Paul, some of which were shown last year in Dresden, are helping a wisely-balanced modernism to victory; and the show of the Berliner Königliche Porzellan Manufactur is most interesting as well in its conservative part as in the modern works of Professor Schmuz-Baudiss.

J. J.

**D**RESDEN. — Mr. Walter Sintenis, recently returned from Brussels, where he has perfected his studies in an atmosphere of which the late Meunier and Lagae were the reigning spirits, invited his friends to a little private show of his work arranged in his studio, prior to sending it all

## Studio-Talk



“GIRL TYING HER HAIR” BY W. SINTENIS

abroad to various of the numerous exhibitions now open throughout Germany.

The supple figure of the girl tying her hair, is one of Mr. Sintenis' earliest works, and was perhaps the first to draw general attention to him. The sureness of delineation displays uncommon talent; and the keen, conscientious modelling speaks of excellent powers of observation. As is to be expected in an early work, the fidelity to nature is rather too insistent, and the work smacks too much of the model. This stricture—if it be accepted as one—is one to which Mr. Sintenis ceased to expose himself at an unusually early period in his career. It cannot be applied even to the over life-size statue of the Negro, although in this case the ethnological interests involved were apt to lead an artist to cling to the model more than at other times. This bronze statue, about eight feet high, was bespoken by the great Hamburg shipping firm of Woermann, who have extensive factories, etc., in our African colonies, and who set it up at the entrance of their new Hamburg offices.

Mr. Sintenis' faculty of seeing the forms of nature in a large way, of simplifying them and imbuing them with grandeur, is strongly in evidence both as to the admirable *Beauty*, *the Conqueror*, and the *Emilia*. A black-and-white reproduction of the

*Beauty* makes the impression of its being a large statue, whereas the capital little bronze is only about twelve inches high. The pose, indicative of a sort of merciless, haughty pride in one's bodily perfection is excellently in keeping with the expression and type of the face: a Juno rather than a Venus. That a certain rigidity and grandeur of style is not at all incompatible with charm and grace is amply proven by the *Emilia* to the very tyro. The treatment of the hair is based upon far-reaching simplification, which puts as wide a gap between nature and the work of art as our imagination can be made to bridge over. But the simplification of treatment, as regards the face, though not as plainly recognisable, is almost as great. Here too all accidentals, all that is ephemeral in nature, is eliminated after the same fashion.



STATUE IN WOERMANN'S COLONIAL OFFICES,  
HAMBURG BY W. SINTENIS



"EMILIA"

BY W. SINTENIS

At present the artist is at work modelling a life-size figure destined to be executed in marble, of a girl, sponging herself, which promises fair to excel all that he has done before. The position resembles in some degree, the antique *Venus accroupie*. His first solution of the problem was made in Brussels, but it did not quite satisfy him. Now he attacks it a second time, and is attaining to a greater harmony of movement and to a more lucid simplification of forms than ever before. H. W. S.



BUST IN TINTED WAX

BY W. SINTENIS

PARIS.—Following the precedent of last year, the Société Nationale des Beaux-Arts has organised a retrospective exhibition at the Pavillon de Bagatelle, comprising this time a collection of feminine portraits by past and present members of the Society. Containing, as it does, many fine things, the exhibition is certainly a pleasing one, but the majority of the pictures shown are still fresh in everyone's memory, having figured at comparatively recent Salons; not a few of them, moreover, are quite *demodé*, and to appreciate them one must hark back some twenty or thirty years.

Having made these reservations, let us pause awhile before some very fine canvases of Gustave Ricard—not, however, without expressing some surprise at finding him here at all, seeing that

he died long before the Nationale was founded. This worthy descendant of the great Venetians is well represented by his famous portrait of Mme. Charles Roux, and, amongst other *morceaux*, an altogether remarkable study. Neither did Winterhalter belong to the Nationale, but we are none the less pleased to see his portraits of the Empress Eugénie and the Duchesse de Morny. The three generations of the Dubufes are represented by works which have a great interest for us; then there is Cabanel, mediocre and out of date; Chassériau,

refined and poetic; Chaplin, somewhat *doucereux* at times, but possessing certain qualities of softness and charm; Courbet, whose great power of expression is seen in his portrait of Marie Crocq; and finally Bastien-Lepage, who is represented by a portrait worthy of the greatest. Of Manet and Berthe Morisot I find no item that reveals anything of significance; and as to works by living artists, most of them have, as already stated, figured in recent Salons, and do not call for further comment here.

It was a happy idea of M. Loys Delteil, the well-known engraver and biographer of Daumier, to organise an exhibition of the great caricaturist's works at the Rosenberg galleries. Last year M. Delteil took a leading part in arranging the Zorn



## Studio-Talk

exhibition, and in this new experiment he acquitted himself admirably. It would hardly be possible to pay too much honour to the memory of Daumier, and it was therefore with the keenest interest that we viewed this collection of his drawings, water-colours, and lithographs, many of which were reproduced in the Special Number which THE STUDIO devoted to him in common with Gavarni two or three years ago.

The exhibition of portraits which the Hungarian painter Rudolph Berény has been holding at the rooms of the "Femina" in the Champs Elysées met with a most cordial reception from the Parisian public. Berény possesses all the qualities which go to make a perfect portraitist—great fidelity to nature and a very extensive knowledge of human physiognomy. Everyone in Paris has been to see his interesting presentments of celebrated or notable contemporaries, among which we observed those of the Prince de Radolin; Hans Thoma, the great painter; M. le Préfet Lépine; the academician, Jules Lemaitre; M. Houssaye, the

*conférencier*; M. Joseph Ménard, advocate; further, the Duc de Trévisé and Count Moltke. Some charming portraits of ladies (Charlotte Wiehe, Louise Bignon)

and a series of studies completed an excellent *ensemble*.

—  
This year, for the first time, the great name of Eugène Carrière was missing from the catalogue of the Nationale's Salon. His admirers have at least had the consolation of finding at the École des Beaux-Arts a collective exhibition of the works of this great painter and great thinker. To analyse and study them many pages



MAIN ENTRANCE TO HEAD POST OFFICE, STOCKHOLM  
F. BOBERG, ARCHITECT

would be required, and we must therefore content ourselves with merely naming this rare artistic treat, while referring our readers to what has already been said about the painter from time to time in THE STUDIO.  
H. F.

STOCKHOLM.—No Swedish architect has of later years attracted more attention than M. Ferdinand Boberg, to whose talent and energy witness is borne by many a lasting monument in the Stockholm of to-day. To enlarge upon M. Boberg's work generally is entirely outside the scope of this short notice, which must confine itself to one of the characteristic features of his style—for he has in reality created a distinct style of his own (*viz.*, the attention given to the entrance) the doorway. Bold and original in his contours, Boberg is fond of fairly simple and



"BEAUTY THE CON-  
QUEROR" (BRONZE)  
BY W. SINTENIS  
(See Dresden Studio-Talk)

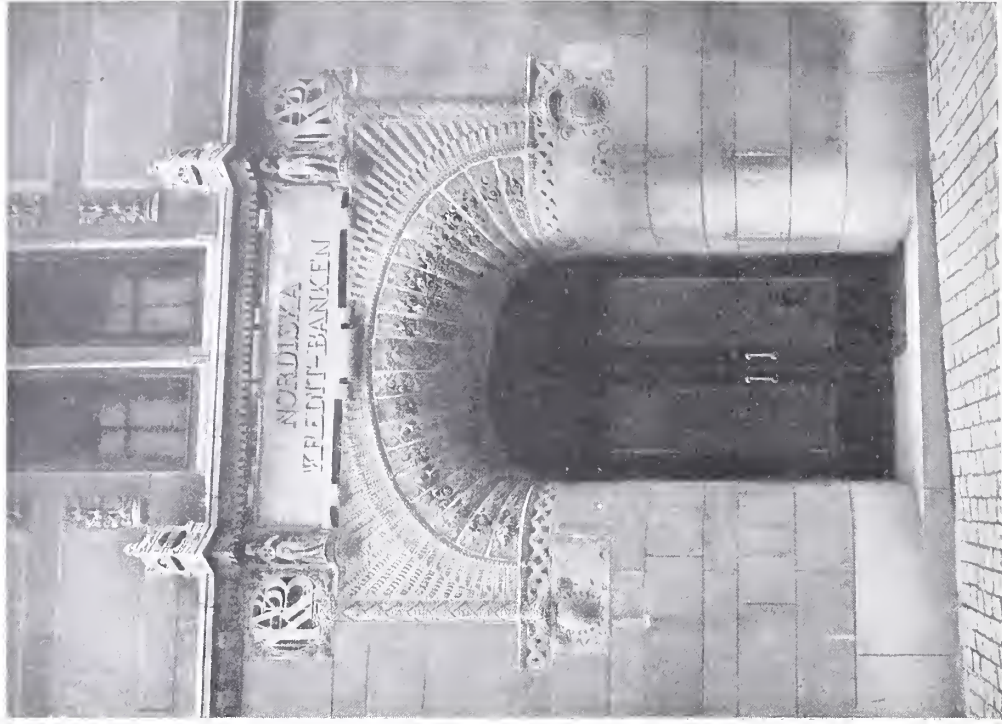

F. BOBERG, ARCHITECT

ENTRANCE TO A BANK

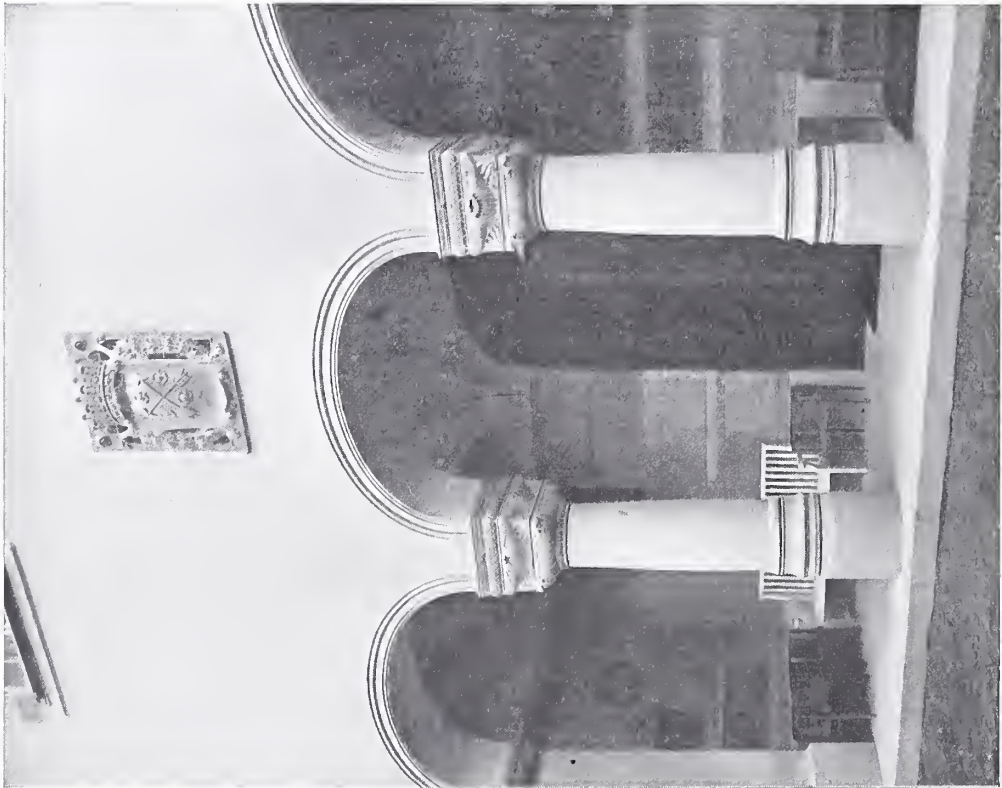

F. BOBERG, ARCHITECT

OUTER HALL OF PRINCE EUGEN'S HOUSE

## Studio-Talk

unbroken surfaces, which lend additional decorative effect to the entrance, upon which he is wont to bestow special care. He has a peculiar gift of blending power and grace so as to produce exceptional results, and there is often about his ornamentation, which is generally ingenious and happy in *motif*, a certain clinging grace altogether his own. I remember some time ago seeing a strong archway, over and across which a beautiful, ivy-like ampelopsis—not the ordinary Virginia creeper—had flung its graceful garlands. Boberg! I thought. His ornamentation in a somewhat similar way seems to develop out of and become part and parcel of what it is destined to embellish, instead of, as is too often the case, looking as if it were patched or stuck on. The three illustrations given here are from the General Post Office, Stockholm—a good type of Boberg's strong work—from a Stockholm bank and from Prince Eugen's delightful and commodious villa at Valdemaresudde, just outside Stockholm, in every respect an ideal home, both for a Prince and an artist. G. B.

**F**LORENCE.—It seems at first sight strange that Ravenna should have taken no active part in the artistic movement of the Renaissance. Proud of her Oriental art, and of the position which by it she had held in earlier days, second only to Rome—this most Byzantine of Italian cities seemed to take but little interest in the wonderful awakening which was

taking place in other parts of the country. Here, as elsewhere, there was a period of warfare and strife; but the quarrels of the small city were quickly engulfed in the more violent dissensions between Rome and Venice, and it was to Venice, with whom she was connected by sea, that Ravenna turned. Close and continuous relations became established between the two cities; inter-marriages were so frequent that among the families of Ravenna you will with difficulty find one that has not Venetian blood in its veins. Thus it happens that the artist of whom we are about to speak can boast of ancestors from both places—his grandmother was a Tiepolo—and his father's family, of Lombard origin, lived for many generations in the city by the sea.

---

Vittorio Guaccimanni was born at Ravenna in 1859. After studying painting under Arturo Moradei, a Florentine, he spent four years at Rome, but the fascination of his native city and the immense plains amid which it is situated forced him to return, and he once more worked under Moradei, who was then teaching in the local academy. Soon one of his pictures was bought by the Ministry of Public Instruction for the Art Gallery of Turin; but in spite of such encouragement financial difficulties forced him to abandon oils for a time and work exclusively in water-colours for a firm of Californian art dealers. He felt, however, that work of this kind was all lost



“PIGNAROLI, OR WILD PONIES OF THE PINETA”

BY VITTORIO GUACCIMANNI

time, and resolved to cut all connections of a purely commercial character and devoted himself freely to real work which, though much less remunerative, was more serious and more really profitable. He began now to direct his efforts to the study of horses and found models of great interest, if not of great beauty, among the trooper horses requisitioned by the Government or among the "pignaroli," the little wild ponies of the neighbouring pine forests.

In 1900 Guaccimanni painted his first large picture—a charge of the Monferrato Lancers at the Battle of San Martino—and this important work was exhibited in Paris and was awarded a medal. After this he returned to small military sketches, working especially in black and white. Some of these, exhibited in Venice in 1905, were bought for the art gallery of that city, which also purchased a larger sketch in oils, of some cavalry soldiers putting their horses to a jump. He has also exhibited at various times at Munich, at Vienna in 1901, at Düsseldorf in 1904, and at Trieste.

Hitherto Guaccimanni had neglected that inestimable source of inspiration which Nature has put at the very gates of his native city, the Pineta—that sacred forest of stately pines which suggested such divine fantasies to Dante and to Byron. He recognised and appreciated the grave beauty

of these woods, the decorativeness of the straight-limbed pines, the varying colour of the tides in the canals, and of the stagnant waters of the pools, the free untrammelled existence of beasts and men, the wealth of stately lines and chromatic harmonies, and has known how to render it all.

Half Romagnole, half Venetian, most of his life has been spent in this remote corner of Italy, and his painting exactly expresses the character of his birthplace. It is above all sincere, for there is never one touch put in for mere effect; to him beauty in Nature is a sacred thing, and his aim is ever to depict faithfully that aspect of Nature which he most feels and loves. If his colouring is subdued, it is at the same time warm and rich in passages. His values are finely balanced and his chiaroscuro is powerful and well managed—especially in his chalk sketches.

Of the three works here reproduced the one given as a supplement is a sketch in two chalks on grey paper. The other two illustrations are from oil paintings. The originals of both are striking for their sobriety of colours, being painted almost in chiaroscuro, the figures silhouetted against the grey of the background. In the *Donne del Pineto*, the women of the Pine Forest are seen returning from their work bending under the heavy loads of hewn branches, and the sacks full of pine cones. It is a winter day—sad, windy and wet.



"WOMEN OF THE PINETA"

BY VITTORIO GUACCIMANNI



FROM A CHALK DRAWING BY VITTORIO GUACCIMANNI.



## Reviews and Notices

Guaccimanni has most admirably rendered the grey desolation of this land in the cold season. In the other picture the little *pignaroli* horses, which he loves to paint, are wearily wending their way homewards. Guaccimanni's horses surprise us by their realism. They are strange little beasts—shaggy, sad and wild, like the tall old pines under which they roam.

Guaccimanni's studio is in Ravenna, and his pictures have not yet been seen in London, but the really good work he does deserves to be known in England. It may be mentioned that his brother, Count Alessandro Guaccimanni, a miniature painter of no small merit, has for some months worked in a studio of his own in London. A. R.

### REVIEWS AND NOTICES

*Venice.* By BERYL DE SELINCOURT and MAY STURGE HENDERSON. Illustrated by REGINALD BARRATT, A.R.W.S. (London: Chatto & Windus.) 10s. 6d. and 21s. net.—To produce yet another volume on a theme so hackneyed as Venice argues, indeed, no little courage on the part of the collaborators responsible for it, yet it cannot be denied that they have made good their claim that the subject is practically inexhaustible, for they have treated it both from the art and literary point of view with a certain amount of freshness. The illustrations after the water-colours of Mr. Barratt, who has lived for many years in the City of the Lagoons and is familiar with her in all her moods, are real triumphs of reproduction, interpreting with rare fidelity the delicate atmospheric effects that are the chief charm of the originals. Rarely, indeed, has full sunlight been better rendered than in the *Gondolier's Shrine*, the *Palazzo Rezzonico*, the *Santa Maria Salute*, and the *View in the Grand Canal from St. Angelo*, which have caught the very spirit of those familiar scenes. Strange to say, however, the artist has not given the same attention to composition as he has to colour, for some of his drawings, notably the *Shadow of the Campanile*, the *Dogana* and the *Library Piazzetta* suffer greatly from the abrupt cutting off of the tops of columns and buildings. Neither—and this is even more remarkable in view of its unique and varied character—has Mr. Barratt made any attempt to render the daily life of the people of Venice, which, for any hint from him to the contrary, might be a deserted city. Fortunately this inadequacy is in a great measure made up for by the redundancy of the descriptions in the text, which call up picture after picture of the

fair Bride of the Adriatic as she was and as she is, realising vividly the romance with which she has been from first to last associated.

*The History of Modern Painting.* By Professor RICHARD MUTHER. Revised. 4 vols. (London: Dent.) £3 3s.—These volumes are, in the main, a republication of the first German edition of this work which appeared in 1894. There has, we gather, been a thorough revision of the original text, and the subject is continued up to the end of the nineteenth century. It has been more especially the accomplishment of this latter task which has called for re-publication of the work. A feature of the new edition is the addition of coloured plates; but these are not uniformly successful as reproductions, and as, moreover, the choice of the pictures reproduced by the three- or four-colour process has not been an altogether happy one, we cannot help thinking that the work would have been better without them. To give the individual artist his proper place, and to analyse his art, which is often the inevitable voice of the moment, in the case of 1,500 artists of many countries, is a remarkable achievement in itself, calling for a wider and a far more scientific interest in the development and the current of art thought than the art historian is ordinarily prepared, or, indeed, qualified, to give. Just this wide interest has, however, carried Professor Muther's picturesque pen into many side issues, his treatment of which changes his chronicle at times into a work of great critical acumen. Reviewing the various influences which have shaped the history of modern art, the author has given us a quantity of highly suggestive writing. At the end of the English survey only does he fail us. The decorative movement in painting has evidently greatly interested him, so that he follows its development as far as possible, and we find an artist appearing so late in the nineteenth century as Cayley Robinson, represented. But of other late century tendencies in England there is little mention, and the history of its last twenty years is strangely incomplete.

*Wild Flowers of the British Isles.* Illustrated and written by H. ISABEL ADAMS, F.L.S. Revised by JAMES E. BAGNALL, A.L.S. (London: W. Heinemann.) 30s. net.—No explanation is vouchsafed why out of the eighty or more orders of flowering plants indigenous to Britain, only twenty-nine have been selected for illustration in this volume, intended primarily, as it appears to be, for the student of botany. As far as it goes, however, the book is a highly meritorious achievement. The seventy-five coloured plates which are the principal feature of

## Reviews and Notices

the volume, comprise in all, three or four hundred of the more or less familiar flowering herbaceous plants of Britain, presented with an unusual degree of accuracy, both as regards form and colour; and in addition to the entire plant, the details of the floral structure are given in many cases, and with sufficient precision to enable the student to study them when actual specimens are inaccessible. Miss Adams's drawings have been admirably reproduced by the three-colour chromotype process, and besides being of service to the botanist, they should also prove a valuable and reliable source of suggestion for the decorative artist. The letterpress, on which great care seems to have been bestowed, consists of technical descriptions of the principal species arranged according to families, a glossary of terms, and a good index. It may be hoped that Miss Adams, who has, by the drawings now published, given convincing proof of her ability as a delineator of plant forms, will proceed with the orders not represented in the present volume.

*The Brasses of England.* By HERBERT W. MACKLIN, M.A. (London: Methuen.) 7s. 6d. net.—Though it contains little that is new, and some of the illustrations have been copied or reduced from those in other books, the author has managed to give a certain freshness to a somewhat hackneyed theme by connecting it more closely than has hitherto been done with the history of the country in which the quaint memorials of the dead he so eloquently describes were produced. Thus he deals with Edwardian, Plantagenet, Lancastrian, Yorkist, Tudor, and Elizabethan brasses, and treats those known as Palimpsest under the attractive headings of the "Spoliation of the Monasteries," the "Suppression of Chantries," etc., thus enabling the reader to study with ease the characteristics of each period, and bringing into vivid relief the priceless value of the surviving relics of a noble art as historic documents written in all but imperishable material, as well as examples of the work of the master craftsmen who designed and executed them. His interesting account of the brasses of mediæval clergy is a complete essay on ecclesiastical vestments; whilst the various appendices dealing with minor groups of brasses, which might perhaps have been with advantage incorporated in the text, display a really remarkable grasp of a subject that would appear to be practically inexhaustible.

*The Art and Craft of Garden Making.* By THOMAS H. MAWSON, Hon. A.R.I.B.A. Third Edition. Revised and enlarged. (London: B. T. Batsford.) 35s. net. *Landhaus und Garten.* Examples of Modern Country Houses, with Plans,

Interiors, and Gardens. Edited, with Introduction, by HERMANN MUTHESIUS. (Munich: F. Bruckmann and Co.). In cloth binding, 12 mks. net.—We are glad to see this new issue of Mr. Mawson's well-known work, which has been out of print for some time. The outcome of an unusually wide experience in the laying out of gardens under all sorts of conditions, the work well deserves the high esteem in which it has been held since its first appearance some seven years ago. In now revising and enlarging the work, the author has made a more thorough and incisive inquiry into the principles upon which successful gardens are founded, and their various ideals, at the same time scrutinising certain examples left by able designers, and examining the problems presented by characteristic sites in typical districts in Britain. In the present edition much larger use is made of photographs for purposes of illustration than in the two preceding editions, there being more than a hundred views in which the author's matured work is thus exhibited. These photographic views are conveniently grouped with the plans relating to them. The volume is handsomely got up, and replete as it is with information and suggestions for the practitioner, the work is certain to maintain its position as a leading one on the subject. We have bracketed with it the volume by Prof. Muthesius, because to a certain extent it covers the same field, though the bulk of it concerns rural domestic architecture, of which a great variety of examples are illustrated from the designs of architects of different nationalities. Both authors have something to say about the relations of garden design to architecture. Mr. Mawson's view is briefly put when he says that in the course of his extensive practice he has realized the fact that house and garden must be complementary parts of a whole, and that while sympathising with those architects who claim the right to design the setting to their houses, he also sympathises with those landscape gardeners who have felt that to ensure a successful garden, it is necessary to have some say in the arrangement and disposal of the house on the site and in the selection of the site itself. Prof. Muthesius takes much the same view on the main question, but his sympathies are apparently more on the side of the architect: if the house is architecture so must the garden also be architecture, he says; meaning, of course, that the order and rhythm which characterise the one should also enter into the other. The view he champions is one which of late years has gained many adherents among architects in Europe and America, many of whom



## Reviews and Notices

especially in Germany, at the present time, devote a great amount of attention to the planning of gardens; though not, it seems, without vigorous opposition on the part of landscape gardeners, who, as Prof. Muthesius tells us, have at their gatherings throughout Germany, uttered protest after protest against the new movement. The gardens illustrated at the end of his volume, are all of the regular, "architectonic" class, though not all of them exhibit the same degree of formality. As regards the country houses with which his volume mainly deals, the diversity of design is too great to admit of any general characterisation; they are representative, however, of the best tendencies in modern domestic architecture and interior decoration. Here, as in the case of Mr. Mawson's book, we have a volume which should be in the hands of every one who is interested in domestic architecture and gardening, whether as architect, designer, or client.

*Dante and his Italy.* By LONSDALE RAGG, B.D. (London: Methuen.) 12s. 6d. net.—To look at Italy through the eyes of Dante himself, and having looked to realise her for others, as she appeared to the poet during his sojourn upon earth, has been the chief aim of the author of this new study. Canon Ragg is steeped to the finger tips in Dantesque lore, is thoroughly familiar with everything written by the man to whom his book is one long tribute of homage, and is gifted with an imagination so vivid that he has been able to piece together a very realistic picture of the period at which his hero lived. He begins with a rapid sketch of the state of Europe as a whole at what he calls the "critical moment of Dante's life, the ideal state of his vision," passing on to concentrate his attention first on Italy, then on Florence, and finally on Dante himself, tracing his literary antecedents, calling up one after another the possibilities of his contemporary authors and of his hosts during the weary wanderings of his exile, the narrative terminating with an eloquent account of the last days at Ravenna, and of the impression caused by the news that the great genius had passed away.

*Eighteenth-Century Prints.* By JULIA FRANKAU. (London and New York: Macmillan.) 7s. 6d. net.—This new edition of a publication that was the outcome of ten years of close study and has taken the position of an authority on the subject of eighteenth-century stipple engravers and their work in colour, appears very opportunely, when many experts are struggling to conquer the difficulties that still beset the adequate interpretation of the masterpieces of the past by means of the

colour process. "She has," to use her own words, "endeavoured to tell the history of the courtship and marriage of stipple engraving with colour-printing, and to recognise and identify their legitimate offspring." Moreover—and this is the secret of the charm of her narrative—she has managed to realise in a really remarkable way the personalities of those who aided in bringing about that union.

*Attraverso gli Albi e le Cartelle.* By VITTORIO PICA. (Bergamo: Istituto Italiano d'Arti Grafiche.) Parts IV., V., and VI.—The three new numbers of this useful publication contain a very representative series of reproductions of Dutch, Belgian, French, Italian, and English black-and-white work, prominence having been given to that of Aubrey Beardsley which seems to appeal with peculiar force to the Italian imagination. As a rule the selections are made with discriminating care, but it would have been well if some of the drawings in Part IV. had been omitted.

Messrs. Dent & Co. have added to their series of "The Art Collections of Europe" *A Guide to the Paintings in the Florentine Galleries* (3s. 6d. net) by MAUD CRUTTWELL. The words on the title-page, "A critical catalogue with quotations from Vasari," explain the scope of the book; and numerous miniature illustrations are given of important pictures described. On somewhat similar lines, except as regards the quotations, is EDITH HARWOOD'S *Notable Pictures in Rome*, also published by Messrs. Dent (4s. 6d. net).

A print which will prove of great interest to Oxonians is that which Messrs. Ryman & Co., of Oxford, are issuing of *The College of St. Mary de Winton, or New College*, from a pen drawing by Mr. Edmund Hort New. Mr. New's aim has been to give a comprehensive view of the College buildings, and to achieve this purpose he has followed the method adopted by Loggan in his *Oxonia Illustrata*, by taking the buildings from an imaginary elevated standpoint. The print is a photogravure, and is issued at £1 1s.

The Report of the Principal of the London County Council School of Photo-Engraving and Lithography (published at the School in Bolt Court, Fleet Street) shows that substantial progress was made during the eleventh session, with which the report deals, in the various departments of the institution. Accompanying the report are some excellent examples of reproductions executed and printed by the students, the high standard of the work reflecting great credit on the Principal and his staff, under whose supervision they were done.

## The Lay Figure

### THE LAY FIGURE: ON RECEIVING IMPRESSIONS.

"WOULD you mind giving me an explanation of impressionism?" said the Plain Man. "I met an artist the other day who said he was an impressionist; he showed me some of his pictures, and they seemed to be nothing but blots and smudges. I could not understand them in the least, and I am afraid I thought they were rather ridiculous. I want to know whether that was his fault or my misfortune."

"I commend you for your humility," laughed the Man with the Red Tie; "most people would not have admitted that such an alternative was possible. The average person who cannot understand a work of art blames, as a matter of course, the artist who produced it and accuses him of not knowing his business."

"That is foolish," replied the Plain Man, "for an artist may fairly be presumed to have some definite intention in everything he does. I am quite prepared to believe that the impressionist's intention is definite enough, but unfortunately I cannot see what it is. That is why I am asking you to help me."

"Well, I should say that impressionism was the faithful and exact representation of certain aspects of nature," said the Man with the Red Tie. "It is, as its name implies, the realisation of the effect produced upon the artist by what he has seen, the representation in a pictorial form of the impression he has received."

"But does he really see nature like that?" asked the Plain Man. "Does a landscape, for instance, seem to him to be merely a lot of spots and streaks of colour? I never came across anything in nature like that."

"You forget you have not the trained eye of the artist," returned the Man with the Red Tie. "He can see much more than you can, and therefore his impressions, being the result of careful and searching insight, are much more vivid than yours."

"You are evading the real point," broke in the Art Critic. "The question is whether the artist sees anything in nature which will at all justify what he represents on his canvas. What is your answer to that?"

"I say that he does," cried the Man with the Red Tie; "because he has acquired the power of analysing nature. His acuteness of vision enables him to look more deeply into things than the merely superficial observer, and conse-

quently to give a view of his subjects that is often too subtle and scientific for the ordinary man to understand."

"That is one way of putting it, certainly," said the Critic; "and if all the so-called impressionists were as subtle and scientific as you say they are, I should be quite prepared to agree with you. But I find neither subtlety nor science in much that is put forward now-a-days as impressionism, and I must confess that our friend's complaint about blots and smudges seems to me to be justified. I deny that artists see nature like that, and I deny that the technical tricks they affect are evidences of their remarkable acuteness of vision or of their deep analysis of natural facts. Such vagaries of expression mean only too often that the man who uses them has merely adopted an eccentric and extravagant convention for the sake of attracting attention—that seems to be the true explanation of their so-called impressionism."

"Then the impressionist is simply a charlatan?" asked the Plain Man. "And his work is, you would imply, deliberately extravagant, and therefore not to be taken as honest art?"

"No, I do not go so far as that," replied the Critic. "In its beginning, what is popularly called impressionism represented the attempt made by certain able artists to dissect and analyse nature's colour and tone effects and to produce upon canvas a vivid suggestion of the vibration of light, and the attempt was a justifiable one enough. But most of the followers of these men have simply adopted a convention which is purely unmeaning and unscientific, and they paint in a perfunctory manner pictures which not only misrepresent nature, but are also absolutely inartistic. They disregard the real subtleties of atmosphere and the true gradations of tone; and they often go out of their way to distort facts into the most displeasing and irritating type of untruths. The serious impressionist is no charlatan, and his work is honest enough even when he makes the mistake of trying to deal with subjects which cannot be properly represented by means of his technical convention. The men I object to are the painters who pretend that their clumsy, uncouth and careless daubing, their presentation of gross and offensive ugliness, their meaningless blots and smudges, are sincere records of nature—real impressions. They are the hangers-on who bring discredit upon the art they follow, and upon the masters whose precepts they profess to respect. I wonder to which class your artist acquaintance belongs." THE LAY FIGURE,



From COLLIER'S WEEKLY

Copyright 1907 by P. F. Collier & Son

**F**LORENCE ENGLAND NOSWORTHY, one of whose charming drawings is reproduced above, has this to say about Strathmore Drawing Boards: *"The Strathmore Drawing Boards give me the best results of any drawing boards I have ever used. The surfaces are solid and bear erasure and scratching without becoming absorbent or spongy. I have used them for about two years and consider them perfect papers for both pen and ink and wash drawings."*

**T**HERE are twenty different kinds of Strathmore Drawing Papers and Boards, each so admirably fitted for its particular purpose (whether the medium employed be pen, pencil, brush, charcoal or crayon) that the leading artists of the country prefer them above all others for every variety of work. Strathmore Water Color Paper is a new item in our list. To say that "it's the Strathmore Quality" is to say enough.

These are for sale by many dealers, but if not obtainable from yours, write us for sample book showing complete line, with address of a dealer.

# Strathmore Drawing Papers Boards

Mittineague Paper Company, Mittineague, Massachusetts, U. S. A.



## RED RUSSIA

By JOHN FOSTER FRASER

With 48 full-page Plates from Photographs. 12mo. \$1.75 net. Postage 10 cents.

*"Authoritative, fascinating, yet realistic to the last degree."*

—LONDON STANDARD.

Some Chapters:

The Gist of the Matter      The City of Terror (Warsaw)  
The Moods of Moscow      The Black Hundred  
In the Caucasus      "Bloody Baku"  
Black Sea Pictures

## STARS OF THE STAGE

A Series of Illustrated Biographies. Edited by J. T. GREIN.

*Profusely Illustrated.* 12mo. \$1.00 net. Postage 6 cents.

**Ellen Terry.** By CHRISTOPHER ST. JOHN.

*A profusely illustrated Biography, containing photographs of Miss Terry in favorite roles; paintings and drawings of her by Sargent, Aubrey Beardsley, Simpson and others, and photographs of her home and farm. Also a complete list of parts played by Miss Terry.*

**H. Beerbohm Tree.** By MRS. GEORGE CRAN.

**W. S. Gilbert.** By EDITH A. BROWNE.

## VERNON LEE

**Pope Jacynth and Other Fantastic Tales.** 16mo. \$1.25 net. Postage 10 cents.

**Genius Loci.** 16mo. \$1.25 net. Postage 10 cents.

**Hortus Vitae, or The Hanging Garden: Moralizing Essays.** 12mo. \$1.50 net. Postage 10 cents.

**The Enchanted Woods:** and other Essays on the Genius of Places. 12mo. \$1.50 net. Postage 12 cents.

**The Spirit of Rome.** 12mo. \$1.50 net. Postage 10 cents.

**Hauntings.** 12mo. \$1.50 net. Postage 10 cents.

*"If we were asked to name the three authors writing in English to-day, to whom the highest rank of cleverness and brilliancy might be accorded, we would not hesitate to place among them Vernon Lee."*

—BALTIMORE SUN.

## NAPOLEON

### THE FALL OF NAPOLEON

By OSCAR BROWNING. With numerous Illustrations.

8vo. \$5.00 net. Postage 25 cents.

*"Throws new light on the most extraordinary character of history."*—N.Y. HERALD.

### NAPOLEON IN POLAND 1806-7

NEW ILLUSTRATED EDITION. By F. LORAINÉ PETRE.

A military history of Napoleon's first war with Russia, verified from unpublished official documents. Illustrations, maps and plans. 8vo. \$5.00 net. Postage 25 cents.

*This important campaign was almost unknown to English readers previous to the publication of this work.*

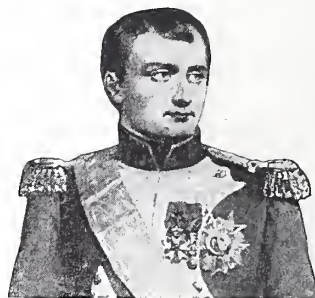

### NAPOLEON'S CONQUEST OF PRUSSIA, 1806

By F. LORAINÉ PETRE. With an Introduction by Field-Marshal Earl Roberts, K.G., etc. With numerous Maps, Battle Plans, Portraits, and many other valuable Illustrations.

8vo. \$5.00 net. Postage 25 cents.

*"A more complete and concise account of this campaign than has yet appeared in English."*—NEW YORK HERALD.

**JOHN LANE CO., 110-114 West 32d St., NEW YORK**

## THE LONESOME TRAIL

By JOHN G. NEIHARDT

Illustrated. 12mo. \$1.50

"Among the foremost of American imaginative writers."

—*Philadelphia North American.*

"A remarkable power of narration. Reminds one at times of Kipling and at other times of Jack London."—*The Bohemian.*

"Power of fascination. To begin one of these widely diverse but always dramatic tales is inevitably to devour them all."—*Chicago Record-Herald.*

"Dramatic and swift of movement. Filled with the truth of every day life, interpreted by an eye that has seen and a heart that lies beneath the commonplace."

—*Louisville Courier-Journal.*

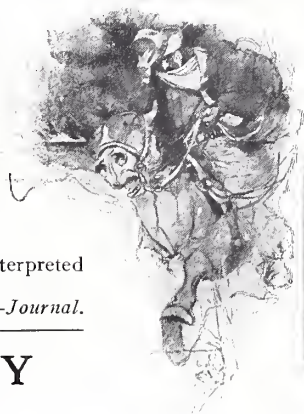

## THE WINGLESS VICTORY

"The London Literary Success"

By M. P. WILLCOCKS. Author of "Widdicombe." 12mo. \$1.50.

"A moving drama of passion, of frailty, of long temptation and of ultimate triumph over it."—*Pall Mall Gazette.*

"Unerring insight into the deep springs of human action."—*London Mail.*

"Miss Willcocks belongs to the school of Thomas Hardy, though her story is devoid of imitation."

—*London Telegraph.*

## FOR THE WEEK-END

A LOVE STORY

By HANDASYDE, Author of "Four Gardens." 12mo. \$1.50

## The DANGERVILLE

A DETECTIVE STORY

"A detective story of which Gaboriau might be proud."

—*London Post.*



## INHERITANCE

By A. C. FOX-DAVIES

12mo. \$1.50.

"Of the Wilkie Collins order."—*N. Y. Times.*

"Plenty of excitement."—*Detroit News-Tribune.*

## AS YE HAVE SOWN

By DOLF WYLLARDE. Author of "The Story of Eden," etc. 12mo. \$1.50.

"Dolf Wyllarde sees life with clear eyes and puts down what she sees with a fearless pen. . . . More than a little of the flavor of Kipling, in the good old days of 'Plain Tales from the Hills.'"—*New York Globe.*



## WILLIAM J. LOCKE

THE BELOVED VAGABOND

"One of the most complete, convincing and entirely delightful characters that have made their debut between book covers for a long time."—*New York Times.*

THE MORALS OF MARCUS ORDEYNE

"By far the best thing he has done."—*Dial.*

AT THE GATE OF SAMARIA

WHERE LOVE IS

A STUDY IN SHADOWS

THE DEMAGOGUE AND LADY PHAYRE

THE USURPER

DERELICTS

IDOLS

THE WHITE DOVE

12mo. \$1.50 each.

JOHN LANE CO., 110-114 West 32d Street, NEW YORK

# REMBRANDT



*Illustration (Reduced) from Rembrandt, John Lane Company*

## THE INTERNATIONAL STUDIO SPECIAL DOUBLE NUMBER, 1907

**Illustrated with Seventy Plates in Color and Photogravure**

"The new method of reproduction combines all the advantages required for a really worthy reproduction of the old masterpieces, and gives the depth of tone and the velvety appearance that distinguished the mezzotints of English engravers of the eighteenth century."—*Dr. Bode, Director Berlin National Gallery, Greatest Living Authority on Rembrandt.*

READY SEPTEMBER 20.

BOUND IN GREEN BUCKRAM, \$5.00 NET.

EXPRESS EXTRA.

**JOHN LANE COMPANY, 110-114 West 32d Street, NEW YORK**

*In writing to advertisers, please mention The International Studio.*

AD. XVI

# PICTURES AND THEIR PAINTERS

By LORINDA MUNSON BRYANT

Illustrated

8vo. \$3.50 net. Post, 25c.

# THE



# SUN

BALTIMORE, WEDNESDAY MORNING, JULY 3, 1907.

14 PAGES

## A TEXT BOOK FOR THOSE INTERESTED IN ART

PICTURES AND THEIR PAINTERS. By Lorinda Munson Bryant. (9 1/2 x 6 1/2, pp. 40. Illus. \$3.50.) John Lane Company, New York.

This carefully prepared textbook offers with its informing text and abundant illustrations the most practical means for obtaining with the least effort a correct and comprehensive view of the history of painting. The work is the production of a teacher whose grasp of the subject is just that which enables her to supply the information for which the great majority of those interested in art are asking. We have here no ambitious effort at criticism, nor have we a work so devoted to the aesthetic side of art that the needs of the beginners in art study, or the great number of persons who want to know something of art in general and little of it in special, are neglected. Our author, in an orderly method, brings period after period of the history of painting before us. She treats ancient painting in a brief, though satisfying, section. Next we have Italian painting, and as, of course, a large section is given to this school, Venetian painting is very properly given a separate grouping. The best part of the book ends with a chapter on the decadence of Italian painting, in which we find a view of the work of Caracci, Domenichino, Guido Reni, Carlo, Dolce, Caravaggio and Salvator Rosa. In the second part of "Pictures and Their Painters" we find considered Dutch, Flemish, Spanish, German, French, English and American painters and their work. In all of these schools the text is well written and remarkably successful in presenting the cardinal facts of men and pictures. The volume is exceedingly well illustrated from the point of view of teacher or student. There are 317 reproductions of typical pictures, and the reproductions in almost every case are such as to be commended as fully illustrating a phase of the art of the painter under discussion. We may, therefore, conscientiously say that the present book is the most useful manual that has been published upon its particular subject.

re. attac that N \$2,000. to place lidentia gua is notes, redeen Blat lution partic choice many lution Alfarc howeve Zelaya.

Natur Washi diploma watch are o. ng ia ev f

to. de ti to Hondu Washi main net Zelaya duras, but hension or evacuati without bors. H the swa

SHOT

Row

[C

an ro th

SAYS

JOHN LANE COMPANY, 110-114 W. 32d St., NEW YORK

In writing to advertisers, please mention *The International Studio*.

PRESS OF REDFIELD BROTHERS, NEW YORK

# "TIFFANY FAVRILE GLASS"

MADE ONLY BY THE TIFFANY FURNACES  
LONG ISLAND, NEW YORK

The distinguishing name is Registered in the United States Patent Office, and is also protected by Letters Patent in Great Britain, France, Germany, Austria and Hungary.

Tiffany Favrile Glass exists under no other name.

Importers and Dealers are notified that the use of this name wholly or partly, in connection with any glass not made by the Tiffany Furnaces, is an infringement, and all persons so using it will be prosecuted.

*Sold in New York only by Tiffany & Co., Fifth Avenue  
and Tiffany Studios, Madison Avenue. : : : : :*

## TIFFANY FURNACES

LONG ISLAND, NEW YORK

## Artists' Materials

LEFRANC & CIE; P. FOINET FILS.  
BLOCKX



### Oil Colors

And all the  
Prominent  
Makes

### Canvas

A Special Feature

### "Plasteline"

For Sculptors

## A. C. FRIEDRICHS

169 W. 57th St., New York

Largest Retail Artists' Material Dealer in the U. S.

Catalogue Free

LONDON

OSAKA

BOSTON

## YAMANAKA & CO.

254 FIFTH AVENUE,

NEW YORK

WORKS OF ART  
FROM THE FAR EAST

Rare Old Paintings and Color Prints a Specialty

## Picture Lighting

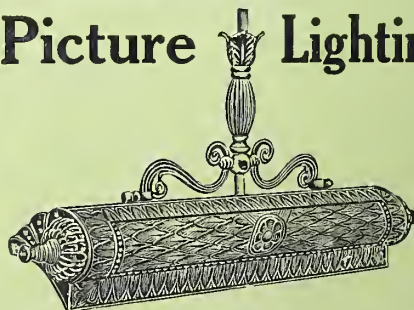

Special Reflectors for Single Paintings, also  
Continuous Reflectors for Galleries.

I. P. FRINK, 551 Pearl St., New York



*The*  
**INTERNATIONAL  
STUDIO**

Reg. U. S. Pat. Off.



**JOHN LANE COMPANY & NEW YORK**

Monthly 50 cts. ~ Yearly Subscription \$ 5<sup>00</sup> Postpaid

## Art Students' League of New York

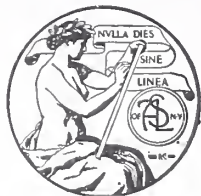

### SUMMER SCHOOLS

Out-of-door classes in Landscape Painting under

**MR. BIRGE HARRISON**

at Woodstock, Ulster County, New York, from June 1st to October 1st.

The City Summer School will consist of classes in Drawing, Painting, Illustration, Composition, and Commercial Design under

**MR. THOMAS FOGARTY and  
MR. WALTER WALZ FAWCETT**

in the American Fine Arts Building, 215 West 57th Street, from June 3rd to September 21st.

Circulars on Application to

The Art Students' League of New York  
215 West Fifty-seventh Street, - New York, N. Y.

## HIGGINS'

DRAWING INKS  
ETERNAL WRITING INK  
ENGROSSING INK  
TAURINE MUCILAGE  
PHOTO MOUNTER  
DRAWING BOARD PASTE  
LIQUID PASTE  
OFFICE PASTE  
VEGETABLE GLUE, ETC.



Are the Finest and Best Inks and Adhesives

Emancipate yourself from the use of corrosive and ill-smelling inks and adhesives and adopt the Higgins' Inks and Adhesives. They will be a revelation to you, they are so sweet, clean and well put up.

At Dealers Generally

**CHAS. M. HIGGINS & CO., Mfrs.**  
Branches: Chicago, London.  
271 Ninth Street, Brooklyn, N. Y.

## New York School of Applied Design for Women

**200 WEST 23d STREET**

(Incorporated 1892)

SPECIAL LIFE CLASS. ALSO SPECIAL COURSE IN  
DESIGN UNDER ALPHONSE MUCHA

Silk and Wall Paper Designing, Antique  
and Costume Sketch Classes, Historic  
Ornament, Architecture.

Apply to **HELEN LOOMIS, Secretary**

## BACK NUMBERS

*THE (ENGLISH) STUDIO*  
Vols. I to IX inclusive. Handsome Uniform  
Cloth Binding Complete, \$100.00 net.

*THE INTERNATIONAL STUDIO*  
Vols. I—XXVII inclusive. Being Complete  
File of Bound Volumes to February, 1906,  
inclusive, \$100.00 net.

*ADDITIONAL BOUND VOLUMES*  
Vols. XXVIII, XXIX, XXX. To Complete  
File up to February, 1907, inclusive, \$3.00  
net per volume.

SEND YOUR BACK NUMBERS  
to the Publishers for Binding in Permanent  
Volume Form.

*Cloth Binding, Uniform with Series, \$1.00  
per volume.*

BEST WORKMANSHIP. MOST REASONABLE RATES

**JOHN LANE COMPANY**

110-114 WEST THIRTY-SECOND ST., NEW YORK

MR.

## WILLIAM M. CHASE

writes us as follows

"I am better pleased  
with your colors, af-  
ter a thorough test,  
than any other  
colors I have used"

Write for booklet "Ullman's  
Manual of Artists' Colors"

**SIGMUND ULLMAN  
C O M P A N Y**

Park Ave. & 146th St., N.Y.

In writing to advertisers, please mention *The International Studio*.

# TIFFANY & CO.

Fifth Avenue and 37th Street, New York

## For Collectors and Connoisseurs

Messrs. Tiffany & Co. extend a cordial invitation to connoisseurs, collectors and all lovers of beautiful things to inspect the objects of interest in their establishment

In addition to an unequaled stock of rich gem jewelry and silverware, they have on exhibition and sale many unusual objets d'Art, virtu and curiosity made on the premises or collected from the art centres abroad; notably, carvings in rock crystal, jade and ivory; bronzes by Rodin, Descomps, and other sculptors of merit; Royal Doulton vases and choice specimens from the noted domestic and foreign art potteries; Chryselephantine Sculptures by Gérôme, Rivière, A. Moreau-Vauthier, Delacour and Allouard; Art Glass by Emile Gallé; Carved Glass from the Paris Salon by E. Michel

Inkstands, Candlesticks, Clocks, Vases, Jewel Boxes and Cabinet Ornaments,—some of lapiz-lazuli, others richly enameled

Visitors incur no obligation to purchase

## Fifth Avenue New York

- ☞ Americans are now building more beautiful houses and are decorating and furnishing them with greater care and in better taste than ever before.
- ☞ The most potent single influence working for higher standards in architecture and decoration is

## *The* Architectural Record

- ☞ If you are interested in building a building of any sort, you will be interested in *The Architectural Record*.

Send for a Sample Copy—Free

THE ARCHITECTURAL RECORD COMPANY

11 to 15 East 24th Street, NEW YORK

841 Monadnock Building, CHICAGO

# *The* AMERICAN ARCHITECT AND BUILDING NEWS

A Weekly Journal of Constructive and Decorative Art. Now in its Eighty-ninth Volume.

A sample copy will be sent on request to readers of the International Studio

We shall be pleased to send also a price list of books published by us and an illustrated catalogue of the most complete and important work on colonial architecture that has ever appeared—“**THE GEORGIAN PERIOD.**”

THE AMERICAN ARCHITECT (INC.)

Kimbel Building,

12 West 40th Street,

New York City

# HOUSE DECORATION @ FURNISHINGS



## WOOD CARVERS' TOOLS

THE GENUINE S. J. ADDIS. LONDON MAKE

Recognized by experts the world over to be the finest quality made

Send for Catalogue No. 2219, Entitled "Wood Carvers' Tools and Accessories"

**HAMMACHER, SCHLEMMER @ CO.**  
 HARDWARE, TOOLS and SUPPLIES  
 NEW YORK, SINCE 1848  
 4th Ave. and 13th St.



## Long Sang Ti & Co. IMPORTERS

307 FIFTH AVENUE, Near 31st St.  
 NEW YORK

Genuine Chinese and Japanese  
 Objects of Art

Real Chinese Jade & Oriental Jewelry  
*Write for Illustrated Booklet A*



## Misses Whittredge @ Barrows

*Interior Decoration*

*General Decorative Work & Designing*

4 WEST 40th STREET, NEW YORK CITY



## THE UNIVERSITY PRINTS

1,500 subjects on Greek and Italian art. Size 5½ x 8 inches. One cent each or eighty cents per hundred. *Send for Catalogue.*  
 Dutch, Flemish and German Series in preparation.

Bureau of University Travel, 16 Trinity Place, Boston, Mass.

*In writing to advertisers, please mention The International Studio.*

## Handbook of Art Smithing

FOR THE USE OF

Practical Smiths, Technical and Art Schools  
 Designers of Iron Work, Architects and Others

By PROF. FRANZ S. MEYER

With an Introduction by J. STARKIE GARDNER

Containing 214 illustrations

One volume, 8vo. Cloth, \$2.40

A most practical and valuable collection of useful designs  
 suitable for all purposes, including Venetian Iron Work.

**BRUNO HESSLING CO., Ltd.**

No. 64 EAST 12th ST., NEW YORK, N. Y.

## VOUGA CELEBRATED FINE ART STUDIES

Latest complete illustrated Catalogue, 30c. New Flower,  
 Fruit, Figure, Landscape and Animal Studies—suitable for  
 Oils and Water Colors. Discounts given in Catalogue.

M. G. PRICE, 359 West 118th St., New York

## We Purchase Designs For Photographic Backgrounds

Good opportunity for artists having  
 new ideas in this direction  
 WRITE FOR PARTICULARS

**ROBEY-FRENCH COMPANY**  
 34 Bromfield Street, Boston, Mass., U. S. A.

## Garden and Lawn Furnishings



## SUN DIALS

with or without PEDESTALS

*Send for illustrated Price List K*

**Hartmann Bros. Mfg. Co.**

New York Office, 1123 Broadway

Mount Vernon, N. Y.

# PICTURES AND THEIR PAINTERS

By LORINDA MUNSON BRYANT

Illustrated

8vo. \$3.50 net. Post, 25c

# THE



# SUN

BALTIMORE, WEDNESDAY MORNING, JULY 3, 1907.

14 PAGES

Text in Irish went to printing, verbatim. Victoria Douce, Wexford.

## A TEXT BOOK FOR THOSE INTERESTED IN ART

PICTURES AND THEIR PAINTERS. By Lorinda Munson Bryant. (9 1/2 x 6 3/4, pp. 440, illus. \$3.50.) John Lane Company, New York.

This carefully prepared textbook offers with its informing text and abundant illustrations the most practical means for obtaining with the least effort a correct and comprehensive view of the history of painting. The work is the production of a teacher whose grasp of the subject is just that which enables her to supply the information for which the great majority of those interested in art are asking. We have here no ambitious effort at criticism, nor have we a work so devoted to the æsthetic side of art that the needs of the beginners in art study, or the great number of persons who want to know something of art in general and little of it in special, are neglected. Our author, in an orderly method, brings period after period of the history of painting before us. She treats ancient painting in a brief, though satisfying, section. Next we have Italian painting, and as, of course, a large section is given to this school, Venetian painting is very properly given a separate grouping. The best part of the book ends with a chapter on the decadence of Italian painting, in which we find a view of the work of Caracci, Domenichino, Guido Reni, Carlo, Dolce, Cararagglo and Salvator Rosa. In the second part of "Pictures and Their Painters" we find considered Dutch, Flemish, Spanish, German, French, English and American painters and their work. In all of these schools the text is well written and remarkably successful in presenting the cardinal facts of men and pictures. The volume is exceedingly well illustrated from the point of view of teacher or student. There are 317 reproductions of typical pictures, and the reproductions in almost every case are such as to be commended as fully illustrating a phase of the art of the painter under discussion. We may, therefore, conscientiously say that the present book is the most useful manual that has been published upon its particular subject.

fo  
sh for  
anical

ING

Whit-  
Little,

cord of  
an acci-  
their past  
which this  
rther com-  
to another  
new and  
ntly been  
e before,  
or in an  
y, while  
ork, is  
passing  
suddenly  
has hap-  
elegant  
he mean-  
r husband  
previously  
or dead. De-  
nds his new  
after some  
nce he ac-  
develop-  
strength-  
an who  
into the  
who has  
to en-  
have  
llowed  
s sus-  
uation  
marvel-  
mysti-  
e story.  
Whitson  
ased on  
UPER.

SAYS

re,  
attac.  
that N  
\$2,000.  
to place  
identia  
gua is  
notes,  
redeem  
Blax  
lution  
partic  
choice  
many  
lution  
Alfarc  
howeve  
Zelaya.

Natur  
Washi  
diploma  
watch

are  
o.  
ag  
la  
ev  
f  
ti  
di  
ti  
to  
Hond  
Washi  
main ne  
Zelaya  
duras, but  
hension or  
evacuat  
without  
bors, H  
the swi

SHOT

Row

ICo

an  
rot  
th

## JOHN LANE COMPANY, 110-114 W. 32d St., NEW YORK

In writing to advertisers, please mention The International Studio.

AD. IV

# F. WEBER & CO.

ST. LOUIS, MO.

PHILADELPHIA, PA.

BALTIMORE, MD.

OLDEST MANUFACTURERS, IMPORTERS AND DEALERS IN

## ARTISTS' MATERIALS, DRAUGHTSMEN'S AND ENGINEERS' SUPPLIES

### SKETCHING MATERIALS

We carry the most complete line of Easels, Stools, Umbrellas, Oil and Water Color Outfits, Thumb Boxes, Umbrella Staffs, etc., etc.

**Air Brushes** and Air Brush Materials.

Everything for the Illustrator.

Complete assortment of the finest quality of **Artists' Brushes.**

**Herbut's Plasticine** a finely prepared anti-septic composition modeling clay.

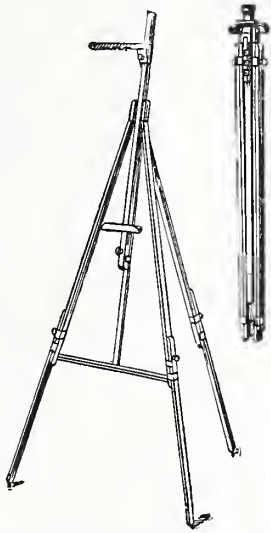

F. Weber & Co.'s Artists' Oils and Moist Water Colors.  
F. Weber & Co.'s "Students'" Moist Water Colors in tubes  $\frac{1}{2} \times 3$ ", made in 36 different colors.  
Send for sample card of "Sphinx" and "Students'" Moist Colors.



A large variety of different qualities of Mathematical Instruments.



**Works on Art** for illustrators, Fresco Painters, Sculptors, Engravers, Lithographers and Textile Workers.

Illustrated Catalogue Vol. 263 sent on application

1125 Chestnut Street,

PHILADELPHIA

## The National Art and Crafts Institute

WASHINGTON, D. C.

Instruction in Composition, Portrait Painting, Illustrating, Pottery Making, Ceramic Painting, Illuminating, Designing, Book Binding, Scientific Tailoring, Millinery, Weaving, Metal Work, Jewelry Making, Cabinet Making, Needle Work, Lace Making, Leather Craft and Interior Decoration.

FACULTY:

ANNA B. SLOANE, Principal.

Mr. Harold L. Macdonald  
Miss Katheryn Watson  
Miss Marian Lane  
Miss Ellen Shindholm  
Mr. Elsworth H. Clevenger

Mrs. Belle B. Vesey  
Mr. Harry S. Michie  
Miss Anna M. Lewis  
Mr. Harry B. White  
Mr. Clara Neehj

Write for Circulars to

127 TENNESSEE AVENUE

## PLASTER CASTS

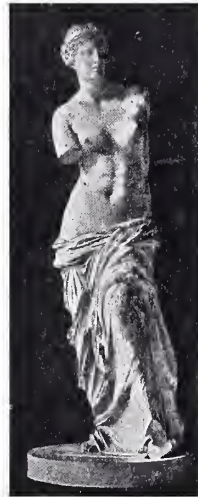

*Special  
Reduced Prices*

Antique, Mediæval and Modern Statuary. Suitable for the Decoration of Halls, Living-Rooms, Dens, Libraries and Studios.

Decorative and Architectural Casts for Schools, Colleges, Libraries, Art Classes.

*"The eye must be trained. We cannot know history without going to the records. We can never know Art unless we accustom the eye to the beauty of form."*

For Full Particulars of this Special Offer Address:

INTERNATIONAL STUDIO

JOHN LANE CO., 110-114 W. Thirty-Second St., New York

**“VIGNETTE”**

**THE WATER COLOR  
BRUSH ATTACHMENT**

*That enables you to do  
with ease what was  
difficult before*

**A** PATENTED attachment of Aluminum Adjustable to Any Brush in a moment of time, which greatly facilitates Wash Drawing, Landscape Painting, Figure Studies, etc.

**A GREAT AID TO THE EXPERIENCED ARTIST  
A MARVELOUS HELP TO THE AMATEUR**

*It supplements the Double End Brush in a very superior way, a slight movement of the hand being all that is necessary to bring the brush with water into play, thus enabling one to gradate colors and washes in a very satisfactory manner. New brushes supplemented without impairing the attachment.*

Made in three sizes (small, medium and large) to accommodate any brush. 35c. each. The three sizes for \$1.00, postpaid.

Money refunded if not satisfactory

**J. W. HAWKINS**  
121 Union Avenue, - PASSAIC, N. J.  
Liberal Discount to Art Schools and Agents

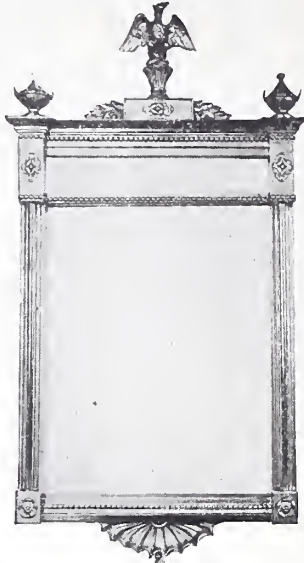

*“When purchasing a looking-glass of your dealer, see that our name is on the back”*

**Colonial Mirrors of All Periods**

*Illustrated Catalogue Free*

**FOSTER BROTHERS, 4 Park Square, Boston**



**You'll Be Glad to  
Receive It**

We'll be glad to send our big 300-page, cloth-bound Artists' Material Catalogue to any address.

It is chock full of interesting information of great value to every person who paints or draws to the slightest extent. Quotes astoundingly low prices on the highest grades of materials. Complete and unabridged—we know of no more comprehensive catalogue in this line.

*We'll send it free to any address on request. Don't fail to address Dept. 25.*

**Hirshberg Art Co.,**  
334 N. Howard St.,  
Baltimore, Md.



**The**  
**OLIVER**  
**Typewriter**

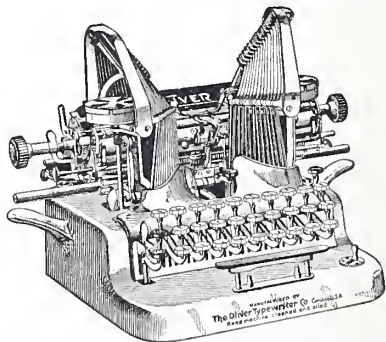

**The Standard Visible Writer**

Universal Keyboard  
The winner of awards everywhere  
Art Catalogue Free Ask for it

**THE OLIVER TYPEWRITER CO.**  
310 Broadway, New York City, N. Y.



# The International Studio

Copyright, 1907, by John Lane Company

---

## CONTENTS, SEPTEMBER, 1907

---

	PAGE
EDMUND C. TARBELL. By Frederick W. Coburn. Twelve Illustrations . . . . .	lxxv
THE CRAFT OF BATIK MAKING. By Mabel Tuke Priestman. Five Illustrations . . . . .	lxxxvii
RECENT WORK BY MRS. HUGO FROEHLICH. By Eva Lovett. Six Illustrations . . . . .	xci
CURRENT ART EVENTS. Two Illustrations . . . . .	xciv
PAINTING AND PAINTERS. Seven Illustrations . . . . .	xcvii
AN AMERICAN VILLAGE BANK. By Henry H. Saylor. Eight Illustrations . . . . .	ciii
EUROPEAN SECTION:	
ROBERT W. LITTLE, R.W.S. A REVIEW OF HIS WORK. By A. Lys Baldry. Nine Illustrations . . . . .	173
LEAVES FROM THE SKETCH-BOOK OF W. H. CHARLTON. Six Illustrations . . . . .	182
THE MANNHEIM TERCENTENARY EXHIBITION. By F. Bentz. Fifteen Illustrations . . . . .	189
THE PHOTO-SECESSION IN AMERICA. By Maude I. G. Oliver. Fifteen Illustrations . . . . .	199
RECENT DOMESTIC ARCHITECTURE. Ten Illustrations . . . . .	215
MODERN STAGE MOUNTING IN GERMANY. II. ORLICK'S "A WINTER'S TALE," AT BERLIN. By Prof. Hans W. Singer. Five Illustrations . . . . .	219
REVIEWS AND NOTICES . . . . .	250
THE LAY FIGURE: ON CHOOSING A SUBJECT . . . . .	254
STUDIO TALK	
(From our own Correspondents):	
LONDON. Seven Illus. . . . .	223
NEWCASTLE-ON-TYNE. One Illus. . . . .	228
LIVERPOOL. One Illus. . . . .	228
EDINBURGH . . . . .	228
PARIS. Two Illus. . . . .	230
BERLIN. Five Illus. . . . .	232
BARCELONA . . . . .	232
COLOGNE. Six Illus. . . . .	236
DÜSSELDORF. One Illus. . . . .	238
VIENNA. Ten Illus. . . . .	240
STOCKHOLM. Four Illus. . . . .	245
BUENOS AIRES. Six Illus. . . . .	245

### COLOR INSERTS:

- A Tinted Reproduction of the Painting by Edmund C. Tarbell, entitled, "The Venetian Blind."
- A Tinted Reproduction of the Statue of John William Mackay by Gutzon Borglum.
- A Colored Reproduction from the Water-Color Drawing by Robert W. Little, R.W.S., entitled, "Moonlight at Florence."
- A Tinted Reproduction from the Water-Color Drawing by Robert W. Little, R.W.S., entitled, "On the Banks of the Tiber."
- A Colored Reproduction from the Chalk Drawing by W. H. Charlton, entitled, "Canal Scene, Quimperle."
- A Tinted Reproduction from the Photograph by Eva Watson-Schütze, entitled, "Girl's Head."
- A Tinted Reproduction from the Photograph by Alvin Langdon Coburn, entitled, "The Duck Pond."
- A Colored Reproduction from the Oil Painting by Ludwig Sigmundt, entitled, "The Old Town."

---

**CHANGE OF ADDRESS** *Subscribers desiring to register change of address must notify the publishers on or before the 10th of the month. Please be sure to give FORMER ADDRESS also.*

## Art Tuition

### Worcester Art Museum

#### ARTS and CRAFTS SHOP

Fully equipped for metal work and enameling. A school of design and metal work will be opened Sept. 30, 1907

#### INSTRUCTORS:

MISS KATHERINE B. CHILD, Assistant in Design in the school of the Museum of Fine Arts, Boston.

GEORGE J. HUNT, Instructor in Metal Work in the school of the Museum of Fine Arts, Boston.

Lecturer on Design, C. HOWARD WALKER, Boston.

Tuition, \$10.00 for each term of ten weeks, or \$25.00 for the full course of thirty weeks.

#### BENCH ROOM TO PROFESSIONALS

at reasonable rates, with a reduction for groups of five or ten.

Rooms will be open from 8 A.M. to 9 P.M.

The City of Worcester is about forty miles from Boston, beautifully situated among the hills of Massachusetts.

Cheaper board can be obtained than in large cities.

For information address Mrs. Edith Loring Getchell, 8 Linden Street, Worcester, Mass.

### School of Industrial Art OF THE PENNSYLVANIA MUSEUM

BROAD AND PINE STREETS, PHILADELPHIA

Thorough work under trained specialists  
in all branches of Fine & Industrial Art

Special provision for classes in Illustration, Architecture, Decorative Painting, and Sculpture, Pottery, Metal Work, Industrial Design, Textile Design and Manufacture.

L. W. MILLER, Principal

**WANTED** a thoroughly competent practical illustrator to take charge of classes in illustration at Art School. References.

Reply to A. S., INTERNATIONAL STUDIO  
110-114 West 32d Street, New York

### COLUMBUS ART SCHOOL

Excellent facilities for the study of Drawing, Painting, Modeling, Design and Illustration. Twenty-ninth year begins September 30, 1907. Write for catalogue to JOHN E. HUSSEY, Director, Columbus, Ohio.

## Art Tuition

### Troy School of Art and Crafts

TROY, N. Y.

EMILIE C. ADAMS, Director

Cast Drawing, Drawing and Painting from Costume Models. Illustration, Composition, Anatomy, Decorative Design, Oil and Water Color, Wood Carving, Metal Work, Leather Carving, Modeling, China Painting. For further information address

Miss EMILIE C. ADAMS, 853 Second Ave., Upper Troy, N. Y.

### OUTDOOR SKETCHING CLASS

Point Pleasant, New Jersey.

From June 1st till October 1st

Out-door figure study a specialty. Pupils can work in any medium.

Address for full particulars. MISS ROSALIE PALMIÉ

Point Pleasant, N. J.

### The London School of Art

Stratford Road, Kensington, W., London, England

Drawing, Painting, Composition, Illustration, Etching

Teaching Staff { JOHN M. SWAN, R. A.  
FRANK BRANGWYN, A. R. A.  
JOSEPH OPPENHEIMER  
JOHN LONGSTAFF

Membership is limited in all classes and students will be admitted in the order of their application whenever a vacancy occurs.

For further particulars, apply to

C. P. TOWNSLEY, Director

### ART ACADEMY OF CINCINNATI

ENDOWED Complete Training in Art SCHOLARSHIPS

*Drawing, Painting, Modeling, Composition,  
Anatomy, Wood Carving, Decorative Design  
applied to porcelain, enamels, etc.*

FRANK DUVENECK	C. J. BARNHORN	HENRIETTA WILSON
V. NOWOTNY	WM. H. FRY	KATE R. MILLER
L. H. MEAKIN	ANNA RIIS	W. E. BRYAN

40th YEAR: SEPT. 23, 1907, to MAY 23, 1908 - - \$25.00

J. H. GEST, Director, - - CINCINNATI, OHIO

Will take a limited number of pupils for ILLUMINATION AND MISSAL PAINTING in my New York Studio—2 lessons a week—beginning in Oct., '07. Terms reasonable.

Address EMMA ISABEL SHEA

Post Office Box 35

Elizabeth, N. J.

## ART STUDENTS

The Publishers of THE INTERNATIONAL STUDIO make the following special offer to Art Students

### THREE MONTHS TRIAL SUBSCRIPTION FOR ONE DOLLAR

THE INTERNATIONAL STUDIO is the Standard Art Magazine. It records and reflects with authoritative articles by skilled critics and with an unsurpassed abundance and quality of illustrations in color, tint, black and white, and line, all the important art movements of the day in this country and in Europe. It does not pretend to be a student's magazine in the sense of concerning itself more or less exclusively with student affairs. It is simply the indispensable periodical for those art students who are genuinely in earnest and care to keep in touch with the work being done by the leading artists of the day. So valuable has it become that a subscription to it is considered by educators to be a liberal course in art study.

"ART IS LONG"—WELL CHOSEN READING IS A LONG STEP FORWARD

THE MAGAZINE SPEAKS FOR ITSELF. TRY IT

# Art Tuition

## ART SCHOOL

Awarded International Silver Medal at St. Louis, 1904

Term: October 1—June 1. For Beginners and Advanced Students.

Design, Modeling, Wood-carving,  
Cast and Life Drawing,  
Water-Color and Painting;  
Evening Class in Costume Drawing.

Instructors:

SOPHIA ANTOINETTE WALKER, HELEN M. TURNER

Young Women's Christian Association,  
7 East 15th St., New York.

Office Hours: 9 A.M. to 5 P.M. and 7 to 9 P.M.

## Eric Pape School of Art

REOPENS OCTOBER 1, 1907

Tenth Year—October 1, 1907, to June 1, 1908.

Head Instructor and Director, ERIC PAPE

No examinations for admission to any of the classes. Students begin by drawing from the nude and costume models as is done in the Paris academies upon which the school is modeled. Fine large studios.

Drawing, Painting, Composition  
Illustration and Decorative Design

Drawing and Painting from "life," separate classes for men and women. Portraiture, Still-life, Flower-painting, Water-color, Pastel, Composition, Decorative Design and Painting, Practical Design for Textiles. Illustration, Pen, Wash, Gouache, Poster and Book-cover designing.

Morning, Afternoon and Evening Classes. Scholarships, Medals and Prizes.

For Illustrated Circulars address the Secretary  
Corner Massachusetts Ave. and Boylston St., Boston, Mass.

## A THOROUGHLY MODERN School of Arts and Handicrafts

Finely Equipped Shops and Expert Instruction in METAL WORKING, BOOKBINDING, WOOD CARVING, MODELING, LEATHER WORKING, POTTERY.

Three Year Courses in Fine Art, Decorative Art, Normal Art, Architecture.

Four Free Scholarships Awarded Yearly. Cash Prizes.  
For illustrated circular, address

THEO. HANFORD POND, Supt.

Department of Applied and Fine Arts  
MECHANICS INSTITUTE, ROCHESTER, N. Y.

## THE MISSES MASON

Studio: 48 East 26th Street, New York

Classes in  
Design, Decoration of Porcelain  
Catalogue on Request

In writing to advertisers, please mention The International Studio.

# Art Tuition

## The New York School of Art

2237-2239 BROADWAY, Corner of 80th Street

WINTER TERM

September 9th, 1907, to June 1st, 1908

Comprehensive Courses in the  
Fine and Applied Arts

Daily Classes in Life, Portrait, Still Life, Illustration, Composition, Design, Interior Decoration and Normal Art. Diplomas and Certificates.

Among the Instructors are ROBERT HENRI, CLIFFORD CARLETON, DOUGLAS JOHN CONNAH, FRANK ALVAH PARSONS, LAWTON PARKER and KENNETH HAYES MILLER.

For particulars address

SUSAN F. BISSELL, Secretary

## New York School of Industrial Art

343 WEST 57TH ST: A PROFESSIONAL SCHOOL of DESIGN

Architecture, Interior Decoration; Textile, Costume & Commercial Design; Art Crafts. Teachers of these Subjects Thoroughly Trained.  
ELISA A. SARGENT, President.

## Los Angeles School of ART and DESIGN INC.

EST. 1887

Every branch in Drawing, Painting, Illustrating; under artist exhibitors in the chief galleries of Europe. Illustrated prospectus.  
L. E. G. MACLEOD, Director, Los Angeles, Cal.

## THE BENSON SCHOOL OF APPLIED DESIGN, NEW YORK

Individual instructions; designing for draperies, dress silks, wall papers, book covers, etc. Pupils' school work shown for sale.

POSITIONS SECURED FOR GRADUATES

Successfully taught at home by

CORRESPONDENCE

321 West 94th Street,

Near Riverside Drive

## MISS EMILIE C. ADAMS MINIATURES

Portraits and Figures on Porcelain and Ivory. Decorative Work in both Mineral Painting and Water Color.

Studios: 745 Third Ave., Lansingburgh, N. Y.  
and at the Emma Willard Art School, Troy, N. Y.

## The Art Institute ART SCHOOL of Chicago

W. M. R. French, Director N. H. Carpenter, Secretary

Study art under the most favorable conditions in this country—in the Art Institute with its art galleries, permanent collections, passing exhibitions, lecture courses, libraries, and constant association with accomplished artists and teachers.

Drawing, Painting, Illustrating, Normal Instruction, Sculpture, Decorative Design and Architecture. Students may enter at any time. No art student, east or west, ought to select his school until he has seen the fine illustrated catalogue of the Art Institute, mailed free on application.

Be careful of the name, the Art Institute.

RALPH HOLMES, Registrar

Dept. P., Art Institute

CHICAGO, ILL.

"THE MOST COMPLETE AND VALUABLE WORK EVER ISSUED ON ANY CRAFT."

# PLASTERING PLAIN & DECORATIVE

*A Practical Treatise on the Art and Craft of Plastering and Modelling*

NEW REVISED EDITION

By **WILLIAM MILLAR, Plasterer and Modeller**

Illustrated by Fifty-five Full-Page Plates, and Five Hundred smaller Illustrations in the Text

Large 4to (11 ins. by 8½ ins.), containing 630 pages, strongly bound in canvas. \$7.50 net (Express Extra)

Some topics treated in this unique and indispensable book:

## HISTORY OF PLASTER WORK

### MATERIALS:

Plaster of Paris, Lime, Mastic, Hair, Cements of all descriptions, with a complete account of

### PORTLAND CEMENT

### DECORATIVE CEILINGS

### MOULDINGS: RUNNING, DIMINISHED AND CIRCULAR

### EXTERIOR PLASTERING:

Instructions for making Facades in Portland Cement and in Colors, Fresco, Fresco Secco, etc.

### MODELLING:

Basic Principles. Proportions of Human Body. Tools for Clay Working. Modelling in Cement, Wax, Tow, etc.

### MOULDING AND CASTING:

How to Make Moulds, cast in Plaster, Wax, etc., etc.

### GELATINE MOULDING

### FIBROUS PLASTER WORK

### COMPOSITIONS:

Papier Maché, Stage Properties. Carton Pierre. Sulphur Moulds.

### GESSO:

Method of Preparation and Application.

### GESSO DURO

### GESSO GROSSO

### GESSO SOTTILE

Method of Making and Manipulating. Full Recipes for Mixing, etc., etc.

### SCAGLIOLA

### FOREIGN PLASTER WORK:

Saracenic, Persian, Spanish, Moorish, Indian, Chinese, Italian, French, German, Austrian, Belgian, Russian, English, Scotch, Irish.

### TERRA COTTA

### PLAIN CONCRETE

### REINFORCED CONCRETE:

Concrete and Iron, Concrete and Wood, Steel Concrete.

### CONCRETE GARDEN FURNITURE

### ARCHITECTURE

Elements applied to Plaster Work.

### TOOLS AND APPLIANCES

JOHN LANE COMPANY, 110-114 West 32d Street, NEW YORK

## WANTED

**NOTE TO SUBSCRIBERS.** The publishers of the INTERNATIONAL STUDIO will buy in copies of the following issues in good condition. These issues having become rare will be bought at 50 cents a copy, though issued at the old rate (35 cents).

1898—February. 1899—January, February, August, October, November, December. 1900—January, March, July, August. 1903—March, November, December. 1904—January, February, June, August, October. 1905—January.

The publishers offer this advanced rate to complete sets with the above numbers which have been in special demand. If you have any such copies which you do not need, address

JOHN LANE COMPANY, 110-114 WEST 32d STREET, NEW YORK

# ARTISTS' MATERIALS

## F.W. Devoe & Co.'s

### Artists' Tube Colors

CANVAS, ACADEMY BOARDS,  
FINE BRUSHES FOR OIL AND  
WATER-COLOR PAINTING, etc.

"THE STANDARD QUALITY"

*Everything in Artists' Materials*

## F.W. DEVOE & C.T. RAYNOLDS CO.

Fulton Street, cor. William  
NEW YORK

176 Randolph Street  
CHICAGO

The Largest Manufacturers and Importers of Artists' Materials  
in the United States

## WM. H. POWELL

Fine Art Gallery, 983 6th Ave., New York

### ARTISTS' MATERIALS

New York Agent for LEFEBVRE-FOINET and  
EDOUARD of Paris

And BLOCKX'S HAND-GROUND, PERMANENT BEL-  
GIAN OIL COLORS and AMBER VARNISH, BEST IN  
THE WORLD, French Canvas and Brushes. Mail Orders have  
prompt attention.

PICTURE FRAMING A SPECIALTY

A WONDERFUL INVENTION!

## ALGUMAR WATER COLORS

BLEND LIKE OIL. DO NOT RUN

Picture upright. No waiting for washes  
to dry. Full instructions free

A. G. Marshall, Thousand Island Park, N.Y.

## WYROPEN

Leading Instrument in Pyrography. Heated by GAS. No Benzine  
or Bellows. All Art Material Dealers; or post-paid for \$1.00 from  
WISEMAN MFG. CO., 147 W. 26th Street, New York

In writing to advertisers, please mention *The International Studio*.

## A. Sartorius & Co.

Manufacturers and Importers of

### Artists' Colors and Materials

#### China Colors in Powder

(In vials or in bulk.) Vials and corks for dealers and teachers  
bottling china colors.

#### China Colors in Tubes

(Oil and Water Preparation.)

#### Artists' Oil Colors, Artists' Water Colors, Artists' Moist Oleo Colors, Artists' Fine Brushes

Write for A. Sartorius & Co.'s Catalogue containing many  
instructions how to mix and apply colors.

45 Murray Street, New York

## S

## PENCERIAN STEEL PENS

never make any "breaks." They  
won't spit, sputter or dig holes in  
your paper. Every Spencerian  
Pen is accurately and carefully made.  
Every one a sleek, easy writer. Points  
always even, smooth, accurately ground.

Try them. Send six cents for postage  
and a sample card of 12 pens, all different  
styles, will be sent you.

SPENCERIAN PEN COMPANY,  
349 BROADWAY, NEW YORK

## DRAWING PENCIL PERFECTION

IN ELEVEN GRADES OF HARDNESS

Send 16 cents for generous samples of  
Dixon's American Graphite Artists' Pencils

JOSEPH DIXON CRUCIBLE CO., Jersey City, N.J.

AD. XI

# The Starr Piano



## The Melody of a Perfect Voice

**I**F YOU have ever heard a perfect voice, you have some conception of the clear, rich, melodious tone of the Starr Minum Grand. Nor is this all. Sustained volume and sympathetic action make it responsive to the mood and the genius of the artist to a degree attained but rarely in the best Concert Grands.

Price, \$700 (freight and handling, additional).

## THE STARR PIANO COMPANY

Factory and Executive Offices

Richmond, Indiana

Handsome catalog in color on request without cost.

### SALESROOMS:

Cincinnati, Ohio, 139 Fourth St.  
Cleveland, Ohio, 736-38 Euclid Ave.  
Dayton, Ohio, 4th and Ludlow.  
Detroit, Mich., 213-17 Woodward Ave.  
(Valpey Bldg.)

Los Angeles, Cal., 413 W. Fifth St.  
Richmond, Ind., 931-35 Main St.  
Toledo, Ohio, 329 Superior St.  
Indianapolis, Ind., 138-40 N. Pennsylvania St.

SELLING AGENTS IN ALL CITIES.





THE VENETIAN BLIND  
BY EDMUND C. TARBELL



# The INTERNATIONAL STUDIO

VOL. XXXII. No. 127

Copyright, 1907, by John Lane Company

SEPTEMBER, 1907

EDMUND C. TARBELL  
BY FREDERICK W. COBURN

BORN at West Groton, Mass., in 1863, trained in the art schools of Boston and Paris, and devoted uninterruptedly since the end of his student days to the practice of his profession in the New England capital, Edmund C. Tarbell has produced a series of remarkably competent works. Among various groups and factions of painters, and by the public at large, he has come to be regarded as among the most able of living painters; admirers do not hesitate to use a stronger term. His art has involved important justifications—of his temperament, of the professional influences amidst which a gifted youth has developed into a consummate artist, of the civic and national conditions in which he has painted. His work throughout has been modern, catholic, thoroughly interesting and universal. It has been free from romantic affectation, from preoccupation with the abnormal or exceptional. It has accepted naively and skilfully interpreted the life of this age. For the most part it is very beautiful; the worst of it aims at beauty and at least attains distinction. Regarding the painter himself I am to tell what I can.

On the ball nine of the Tavern Club of Boston in its annual contest with the rival St. Botolph Club, a stocky third baseman hugely enjoys the putative witticisms of coaches and crowd, the hooting and tooting, the frequent misplays and the more infrequent recrudescence of student-day brilliance. He plays fairly good ball—an indication of his temperament. To relish, at forty-five, the tingle of handling a hot liner argues inhibited hardening of the arteries, persistent youthfulness. That certainly is one of Mr. Tarbell's qualifications to paint. He is of the "young in heart," to use Arthur Pier's phrase. He has alacrity, buoyancy, vitality.

Admission secured to the studio in a frowsy building over a saloon in a decadent part of Dartmouth Street—the door is usually locked and a placard announces that the occupant has gone to Haverhill for three weeks—one is in presence of a technician who seems to paint with his eyes rather than with the brush. His concentration has an outward aspect of desultoriness. Ten minutes of glancing at the canvas, occasionally, casually, as it were, precede perhaps five or ten seconds of spirited brushing-in. Then another period of waiting and watching for a suggestion. Of intense preoccupation there is no outward evidence. The painter appears to seek detachment from his task. He has the "will to refrain" by which alone universality is imparted to art. The things not done, the eliminations, the inhibitions of original impulse—these, in his present philosophy of painting, outweigh facility and tricks of execution. Yet Mr. Tarbell is, on occasion, one of the most facile of draughtsmen.

The school connected with the Boston Museum of Fine Arts has been, up to this time, small and provincial. Its student body is drawn mostly from the immediate neighborhood. Its membership is less than one-tenth that of the largest of American art schools; it is smaller than that of many institutions in cities of second and even third class. Yet it has high standards and a remarkable record for efficiency—as was demonstrated when at St. Louis it won the Grand Prize over all American competitors. I recall that when I was a member, some years ago, of the governing body of the Art Students' League of New York Mr. John La Farge, then assisting us in an advisory capacity, counseled sending a committee over to Boston to see some of the painting done in Edmund Tarbell's classes. Two of our members went, with, I think, some hope that the senior instructor at the school in Boston might be persuaded to move to New York. Their visit was at least pro-

*Edmund C. Tarbell*



PORTRAIT  
STUDY

BY EDMUND C.  
TARBELL

ductive of Joseph De Camp's teaching at the League for a time, to the high satisfaction of the women's life class; but Mr. Tarbell remained at the Museum of Fine Arts, where with notable faithfulness, patience and insistence on severe draughtsmanship he still instructs the students sent up to him from the classes of Messrs. Benson, Hale and Paxton. At recent annual exhibitions of the school much better drawing and painting have been shown than at average exhibitions of, say, the Boston Art Club or the old National Academy of Design.

As a young boy Mr. Tarbell got himself expelled from one of the Boston public schools, resolved to study nothing but art—an incident which he explains amusingly in a letter from which I wish to quote:

“My father and his sister both drew and painted, or studied, in an amateur way. But my father died when I was quite young and after a few years my mother married again, and she and her husband were obliged to go to Milwaukee (since proven famous), as he was engaged in business there, leaving my sister and me with our grandparents to go to school—which she did, and I sometimes; but I always drew, even in kindergarten. When I



Copyright 1905  
by Tarbell

*Copyright, 1905, by Edmund C. Tarbell*

A GIRL CROCHETING  
BY EDMUND C. TARBELL

## Edmund C. Tarbell

got to be about ten I decided to be an artist, but did not tell anybody. I also, in my modest way, decided that I was going to be the best one that ever lived. All this time I played ball, swam (not bathed), and sailed boats in summer and skated and coasted in winter (in fine weather); in bad weather I painted (marines).

"When I got a little older I went to an evening drawing school of which Mr. Bartlett (of the Normal Art School) was principal; also one started at the Art Museum. I think W. A. G. Claus was an assistant in this, under Grundmann.

"All that was fine, but my grandfather died

when I was fifteen and my mother and stepfather came home. They wished me to study and go to college, and I wanted to paint. I finally decided the matter by getting expelled from school (I am not very proud of this part); and asked them to allow me to study either with Hunt or at the Art Museum. It was decided that that was an absolute waste of time and money, but that if I was so crazy to be a *artist* I should be indulged, and I was placed at the W. H. Forbes Lithographic Company as an apprentice at nothing a week for one year, and after that what they thought I was worth or would pay. I was there three years and I think it was the best start I could possibly have had. After that my family allowed me to go to the Art Museum, and I had no further serious trouble about being allowed to become a painter, although a mild remonstrance was raised from time to time, as I was not what you might term a brilliant financial success."

The training in the lithographic establishment proved valuable, as Mr. Tarbell concedes. It was fortunately interrupted before it was carried too far. Working side by side with the boy was an older man, Horace J. Burdick, now a Boston painter. Mr. Burdick's remembrance of young Tarbell is that at sixteen he was an extraordinarily talented draughtsman, and that personally he was an alert youth, with fondness for the latest bit of slang or topical song. The advice of his companion in the shop had much to do with causing Mr. Tarbell to give up lithography and enter the school of drawing and painting at the Museum of Fine Arts. The director at that time was the late Otto Grundmann.

After the Boston school, in due course, Paris. The masters there were Boulanger and Lefevre. Their admirable teaching was supplemented by influences outside the classroom. Impressionism was at its height in Paris during the early eighties. In those days one read Chevreul and Rood and confessed to an opinion that no one before



GIRL WITH DOG

BY EDMUND C. TARBELL



THE BREAKFAST-ROOM  
BY EDMUND C. TARBELL

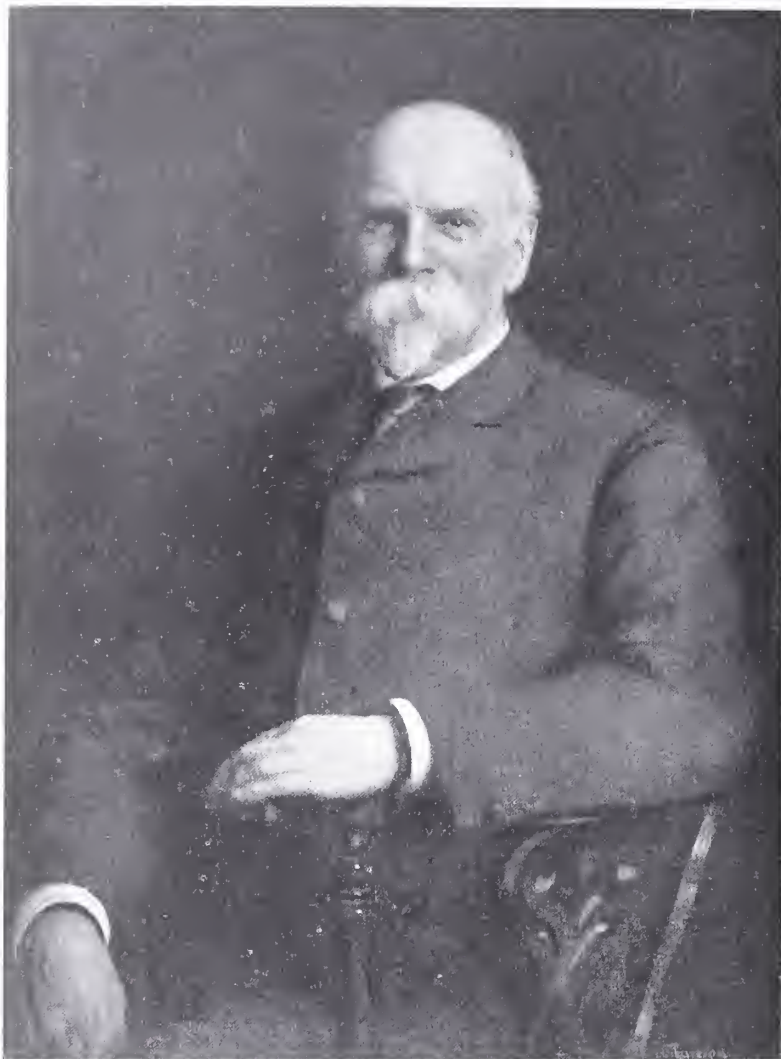

PORTRAIT OF GENERAL CHARLES  
GREELEY LORING

BY EDMUND C.  
TARBELL

Manet understood values. The somberness of the present "depressionism," as represented by Cottet and Lucien Simon and their followers, had not yet checked the advance of French painting in the direction of luminosity. Approximate success, at least, had been reached, for the first time in the history of art, in fixating the glare and shimmer of the sunlit world. "Discard scale, relativity, depth. Make the lower values as they are in nature, even though the higher notes fuse into indeterminate chalkiness."

To all this doctrine of the progressives the talented young fellow from South Boston subscribed enthusiastically. No young painter, it is safe to say, ever brought back to this country a better appreciation of the artistic possibilities of

impression, none has been less enslaved by its methods, its tricks of facture.

The group of artists among whom Mr. Tarbell, returned to Boston, quickly became a leader included his studio mate, Frank W. Benson, less of a pleinairist at the outset of his career than he now is; Childe Hassam, who was preoccupied for some years with illustrating; Willard L. Metcalf, then as to-day a brilliant experimentalist; Joseph De Camp, a Munich man originally but thoroughly sympathetic with the radicals. A little later there returned from Paris Philip L. Hale, William M. Paxton, Ernest L. Major and several others who had fallen under the influence of the gospel of luminosity.

The field in Boston seems to have proved to be too narrow for so many impressionists; two of them, at all events, Messrs. Hassam and Metcalf, followed Thomas W. Dewing to New York, where they fraternized with J. Alden Weir, Robert Reid and John H. Twachtman, whose heterodoxy had be-

gun to produce consternation in metropolitan art circles.

An outcome of the stand made by the groups of impressionists in the two cities was the formation of "Ten American Painters" ten years ago this coming winter.

Early in 1898 Messrs. Tarbell, Benson and De Camp, of Boston, and Twachtman, Reid, Simmons, Metcalf, Dewing, Weir and Hassam, of New York, constituted themselves a band of secessionists from the Society of American Artists, originally a dissenting body itself, but already plainly destined, as the radicals foresaw, to be piped back by a recessional promise of financial prosperity into the orthodox fold of the Academicians. The "Ten" have held well to-



THE STUDIO REHEARSAL  
BY EDMUND C. TARBELL

## Edmund C. Tarbell

gether. The only break that has occurred in their ranks was that caused by the death of Mr. Twachtman, whose place has been taken by William M. Chase.

Justification of the aims of "Ten American Painters" has been abundant. Instead of creating a scandal or raising a laugh, most of their works have been based on the fundamental qualities of the painter's art, and hence have gained general respect. Witness particularly Mr. Tarbell's contributions: *The Venetian Blind*, *The Breakfast-Room*, *A Girl Crocheting*, *A Girl Mending*, the *Portrait of Miss Hyde*, and many more. These certainly are well-balanced works, true to the painter's axiom of "making it like," without niggling or subterfuge. They are concerned solely

with the things which are proper to painting, for Mr. Tarbell's art is never allegorical nor, to use one of his own quaint terms, "paregorical." A breakfast-room of the well bred, a Venetian blind in one of the houses of the comfortable, a young Canadian nurse doing fancy work at a mahogany table beneath a reproduction from Velasquez—any such motive may furnish Mr. Tarbell with a pretext for an extraordinarily skilful arrangement of color tones.

This kind of painting is, of course, objective. It is preoccupied consciously with representation; it is decorative unconsciously. To regard it as lacking on that account in imaginative power—a criticism that has sometimes been directed against Mr. Tarbell's pictures—is to stand convicted of

misunderstanding the artistic proposition.

For the line of cleavage between imaginative and unimaginative does not coincide with the line that separates objective and impersonal from personal and subjective, but simply between well-conceived and ill-conceived art of whatever type. To image clearly the processes by which the thing desired may—indeed, from inner compulsion must—be accomplished so that in the final result there shall inhere no trace of blundering incompetence, no trusting to luck to muddle out somehow, no dependence upon trick or subterfuge—that is, obviously, the rightful province of artistic imagi-



NEW ENGLAND INTERIOR (UNFINISHED)

BY EDMUND C. TARBELL



## Edmund C. Tarbell



ACROSS THE ROOM

BY EDMUND C. TARBELL

nation. Subject and style are alike immaterial, providing they meet temperamental needs. Mr. Tarbell is now and then felicitated because he seems to have entered upon his "second manner," one in which he has laid aside, in painting works of a certain character, the method of using *taches* of unjoined pigments to secure vibration of color and, hence, luminosity. In reality, whatever the influence at present of the style of Vermeer, Pieter de Hooghe and the other "little Dutchmen," the disposition to paint with vibratory color whenever the subject—as in full sunlight—demands such treatment has not disappeared. A recent landscape, now in the Museum of Fine Arts, a light-spotted river bank full of sparkle and brilliancy, is a crowning achievement of outdoor painting. In the studio, Mr. Tarbell would no doubt say, it is unnecessary, in order to "make it like," to accept sacrifices which the pointillionist formula involves. With values that go low, and with few even of the upper notes that cannot be matched with paint, a scale is adaptable which not only conveys a truth-

ful impression, but admits of considerable elaboration. The present ideal is to carry a painting as far as can be done safely. But if you care to work outside you had still best follow Monet.

High professional standing was gained very soon after Mr. Tarbell's return from Paris. This has been attended with considerable financial success in recent years; though that has been a matter of comparatively little concern to the painter. In the exhibitions he has gained the honors and distinctions which by a sort of routine come to the prominent members of the different artistic groups. Prizes and medals, as every insider knows, are often awarded for perfunctory reasons. "So-and-so is a good fellow, and needs money. He had a lemon at St. Louis. Let us at least give him the Whoopenheimer Medal this year." "Smith is the best man among the younger League crowd and it is time one of those boys got some recognition. Never mind what his picture is this year. It's his turn for a prize."

Such as they are, however, Mr. Tarbell, especially



A GIRL MENDING

BY EDMUND C. TARBELL.

for a man living outside of New York City, has had a goodly number of the conventional awards; among others, of the Shaw fund of the Society of American Artists, 1893; the First Hallgarten Prize of the National Academy of Design, 1894; the Walter Lippincott Prize of the Pennsylvania Academy of the Fine Arts, 1895; the gold medal of the Philadelphia Art Club, 1895; the first prize at the summer exhibition of the Worcester Art Museum, 1900; the Clark Prize of the National Academy of Design, 1900.

The works thus honored, and many other pictures besides, have been steadily well received

by the exhibition-going public. New York saw and liked one of the most complete of the painter's "one-man shows" at Montross's gallery in February, 1907. Boston has been very familiar with his works since 1891, when an important two-man exhibition at the St. Botolph Club first made the New England public aware that Messrs. Benson and Tarbell were young men who would go far. Mr. Tarbell's *The Opal, a Study in Yellow and White*, which has frequently been imitated, belongs to this period.

At the World's Columbian Exposition of 1893 the young Boston painter was represented by two



*By Permission of N. E. Montross  
Owned by F. P. Carpenter*

BREAKFAST ON THE PIAZZA  
BY EDMUND C. TARBELL

## Edmund C. Tarbell

brilliant outdoor canvases, *The Girl and the Horse* and *In the Orchard*, and by a portrait, *My Sister Lydia*. In the official handbook of the exhibition, many of whose illustrations have begun to appear archaic, these still retain their look of freshness and modernity. Arrived in Chicago from the national capital, then unaccustomed to art more stimulating than Bodenhausen's *Madonna*, or Thomas Hovenden's *Jerusalem the Golden*, I recall vividly a feeling of admiration for a man who had the audacity thus to paint conventional society without artistic conventions. No one in Washington, in the early nineties, was making masterpieces

of groups of up-to-date young persons arrayed in white duck. No one at that time, I suspect, had the technical equipment to do so.

In 1894 Mr. Tarbell exhibited with Joseph De Camp, Frank W. Benson, Theodore Wendel, Dawson Watson, Philip L. Hale, Frederic P. Vinton and Lilla Cabot Perry at Chase's Gallery, Boston. On an old catalogue of this exhibition I find marked against the Tarbell contributions, 22. *Girl in Pink*, and 23. *Study in Sunlight*, the words, "His best." He has since done much better.

His first one-man exhibition was held at the St. Botolph Club, Boston, in 1898. A second exhibition was opened at the same place in 1904, at a time when the Whistler Memorial Exhibition was on at Copley Hall. Many of us who took in both these shows felt that the Tarbells did not suffer by comparison with the Whistlers. In illustration of this impression a portion of an eloquent appreciation in the *Boston Transcript* by a fellow-artist, Philip L. Hale, is worth quoting. It indicates, certainly, the honor in which Mr. Tarbell is held among painters of his own persuasion; other groups in his home city do him scarcely less. Mr. Hale at that time wrote:

"Don't let us, as we go to the Whistler show and admire his finer works, pray don't let us forget that there's a show in town where equally fine things



MARJORIE

BY EDMUND C. TARBELL

## Batik Making

are to be seen—paintings which, I think, in all respects are as good and in many respects better. When Rubens was at Madrid, Velasquez was none the less a great painter because the mighty Fleming was in town. Then they may have had simple-minded townsmen who dared to think the Spaniard the better painter. At all events, because Whistler is *a la mode*, because all the street cars have signs, 'This way to the Whistler Show,' because people have come all the way from Chicago to be at the private view; let us not for these weighty reasons forget our fellow-townsmen, who is alive, who can appreciate our praise and our backing up, and who deserves for his work every whit as much praise as any man who has touched a brush these twenty years.

"And if some kind and omnipotent fairy were to give me the power to own five pictures taken at will from either of the exhibitions, I would choose: *The Venetian Blind*, the best picture that has been done in America; *The Girl with a Dog*, as fine as a portrait by Veronese; *The Breakfast-Room*, which the *Transcript's* critic rightly called one of the best interiors done since Pieter de Hooghe, and last, that charming vision, *The Blue Veil*.

"But I see I have only chosen four! What should the fifth be? Why, to be broad-minded,

fair-minded, to give every one a chance, if the fairy still remained beneficent, I might choose Whistler's *Little White Girl*."

Word has been spread among artists these many years that Boston is a poor place in which to settle. The New England city has, it must be conceded, lost to New York and Chicago a number of brilliant painters and sculptors. But some at least of these, it may be suspected, were men avid of early success. It is unquestionable that those who have stayed in Boston, and who have advanced in professional ability, have not lacked appreciation either at home or throughout the nation. That Boston has become a good city in which to grow is attested by the steady improvement in the quality of work of the group of painters among whom Mr. Tarbell has been a leader for two decades. It is hard to say in what city of the world any better painting is being done to-day than in Boston.

### THE CRAFT OF BATIK MAKING BY MABEL TUKE PRIESTMAN

THIS special branch of applied art is a most interesting evolution of the primitive art of batik making of the inhabitants of Java. The term batik literally means to engrave,



## Batik Making



BATIK

DUTCH

draw or write with a sharp instrument, which was done by the Greeks and Romans, who wrote their letters on wax tablets. To-day the word batik indicates the special Javanese method by which materials are decorated.

The elementary principle of batik making is to cover cloth with a certain composition, which is absorbed by the material upon which it is placed, which prevents the color from penetrating the covered parts when placed in the dye bath. The preparation is afterwards removed, when it will be found that the parts that were covered have kept their original tint while the uncovered parts have taken the color of the dye. Many inhabitants of the Indian archipelago make use of these elementary principles in the decoration of their native clothing and the people in the beautiful island of Java are renowned for their batik work, which has reached a high stage of excellence.

Another primitive way of batik making, based on

the same fundamental idea, was in vogue among the Kei islanders. Pieces of bamboo which had been cut out in various figures were sewn onto clothing, which was then submerged in the dye tub, when the decorations showed themselves as printed on a contrasting color.

The Aroo islanders had a still more primitive way of decorating their sarongs. These were made of plaited pandanus leaves. Pieces of bamboo or other non-porous materials were stitched onto the sarongs, after which they were exposed to the smoke of their fires. In this way the uncovered parts gained a brownish hue, while the protected figures remained the original color of the material.

The craft of batik-ing is the favorite occupation of the upper classes among the women and girls of Java. The knowledge of perfecting this industry having been passed down from mother to daughter for many generations, they have become past masters in this art, and are born with an aptitude for the technique of batik making. Visitors to this beautiful island always make a point of seeing the batiksters at work. The ease and graceful swiftness with which the batik maker manages her instrument, moving it over the material she is to decorate in delicate curves, straight lines and subtle hatching, claim the admiration of the visitor.

Many attempts have been made in later days to obtain these primitive effects by printing processes, but little success and a good deal of trouble have been the only results of these experiments.

There is no reason why this beautiful art should not be perfected by the people of our own land, and a description of the methods employed

## Batik Making

should be an incentive to craftworkers to experiment in this direction. The best "reserve" to prevent the absorption of the dye is ordinary bees-wax; this can be melted at the low temperature of 62 degrees; the wax completely permeates the tissue of the material which it covers and when placed in the dye-bath protects the material in the most perfect manner. Having partly covered it with wax, it is placed in the prepared dye, which

is of so low a temperature that it will not melt the wax. It is allowed to remain in the dye until the color is thoroughly absorbed, when it is hung out to dry. When it is perfectly dry it can then be placed in boiling water, which melts the wax, causing it to rise to the surface, when it can be skimmed off and used again for other work. This is the process for one color, but for several colors separate dippings are required. For instance, batik which has to ultimately be in white, blue and brown must have the white and brown parts covered with wax. Then the sheet is plunged in blue dye. The wax is then removed, and again applied on those parts which have to be white and blue. The material is then placed in the brown dye, and again dried. This is the most troublesome part of batik making, but the majority of craftsmen in Europe who are doing this work do very little of it in several colors, confining it usually to two contrasting shades. The process of applying the wax is the fascinating part of this interesting craft. A small reservoir of thin red copper is filled with wax. This has a hole at the end which allows the wax to flow onto the material. As the

making of batik is unknown as yet in America, these instruments cannot be obtained. Craftsmen must, therefore, work out their own way of doing it. Our illustration shows an implement I had made for my own experiments, but this was not evolved without a good deal of trouble and thought. First of all, I bought a fresco painter's nozzle, but owing to the gutta-percha bulb not holding the heat sufficiently, even when immersed in hot water, this

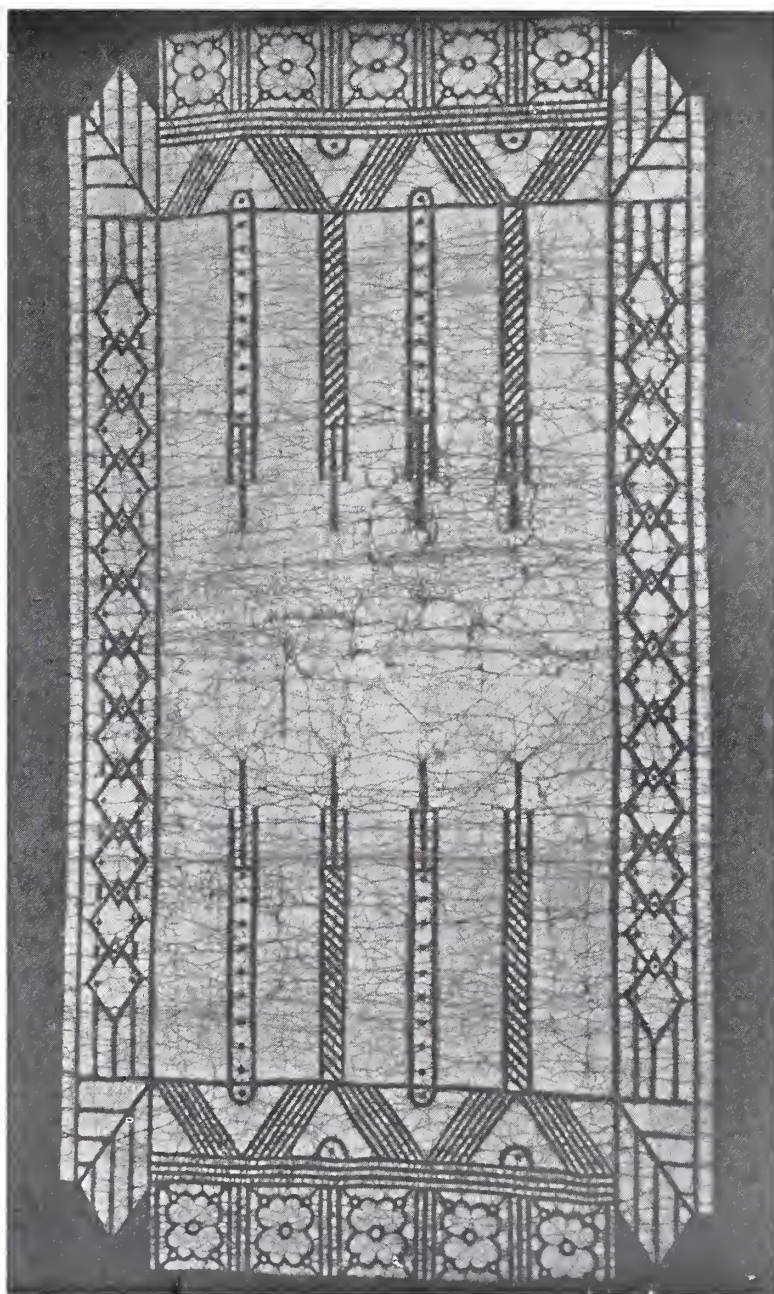

BATIK

DESIGN FOR DRAPERY

## Batik Making

had to be relinquished for something more practical. I then took a tin spoon and shaped the point so as to allow the hot wax to flow and kept refilling it with hot wax as it was needed. This only partly answered, although the wax flowed in a thin, fine stream; when tilted it was apt to run under the spoon and drop on the material in the wrong places. So this also was given up. I then had made the instrument shown in our illustration, which consists of a copper reservoir soldered onto a band of copper which was inserted into a wooden tool-handle. A long steel nail was placed inside the reservoir so as to drop down and fill the hole when moving the reservoir over the work. By a simple contrivance of string wrapped around the finger the nail can be raised or dropped to control the flow of wax. This seems to answer perfectly, but it would be best in doing a good deal of the work to have a



BATIK

DECORATION FOR CHAIR COVERING

number of these reservoirs made so that the flow of wax can be large or small according to the dimensions of the hole in the end of the reservoir. It might be advisable to buy a painter's nozzle outfit and use all the appliances that go with the nozzle and adjust them to the copper reservoir. As these are made with elongated openings, rows of holes and other apertures they would be convenient. As the wax must be hot it is best to have a pan containing the melted wax on a gas stove or spirit lamp beside the worker.

A knowledge of drawing is a necessity in this craft, as bold, free lines and curves are what the work requires. The true batik maker does not even resort to the pencil for making the design, but draws directly onto the material with the instrument containing wax. Of course, there is no reason why the design should not be traced first, if the batikster prefers to do it, but the bold barbaric work loses if the primitive manner of doing it is departed from. As children of seven years of age can do the work in Java without drawing it first, an American should be able, with practice, to get good results without this aid.

Batiks can be made for many purposes. Cotton table-covers, hangings, bags, pillows and chair-



BATIK

SUGGESTIVE DESIGNS



## Mrs. Hugo Froehlich

covers; in fact, even friezes can be decorated with it, so that there is no limit to its possibilities, or to the materials which can be used when the novice has acquired skill.

Batiks can be dyed deep blue, red or green according to the dominating color of the rooms in which they are to go. If colored material is used notice must be taken of the various shades it can be dyed, always remembering that the dye must not be above 60 degrees or it will melt the wax and the batik will exist no more. There are many dyes sold on the market which can be used in this work, and specific directions are given in every case.

Java being a Dutch possession, the people of Holland have always taken a deep interest in the development of batik and most of the work at present emanates from a few studios in Holland. A deep interest is also being taken in other countries owing to batiks having been seen at various European arts and crafts exhibitions. Dutch artists have developed so far in this art that they are now doing it on parchment, linens and velvets and for upholstery work. Owing to the demand being entirely beyond the output, batik decorations are

very expensive, but the few pieces I have seen have made me long to become an adept at this beautiful and interesting craft. So far I have only experimented in the most primitive manner, but desire to let others know about batik so that they may evolve new ideas and themselves develop this beautiful craft while it is still undeveloped by Americans.

Most of the illustrations are from a studio at Apeldoorn, Holland, where one woman has perfected this craft, having worked it out for herself, and has taught her methods to over thirty girls who faithfully carry it on.

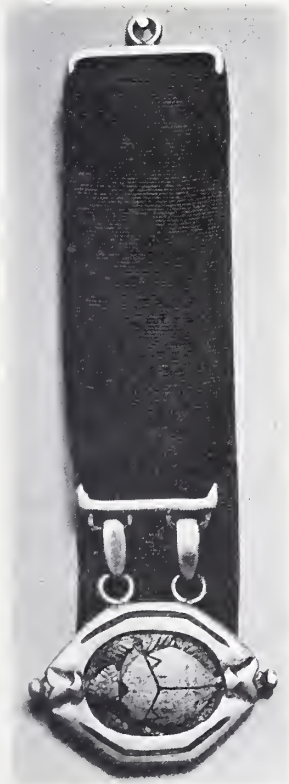

SCARAB IN  
SILVER

BY MRS.  
FROEHLICH

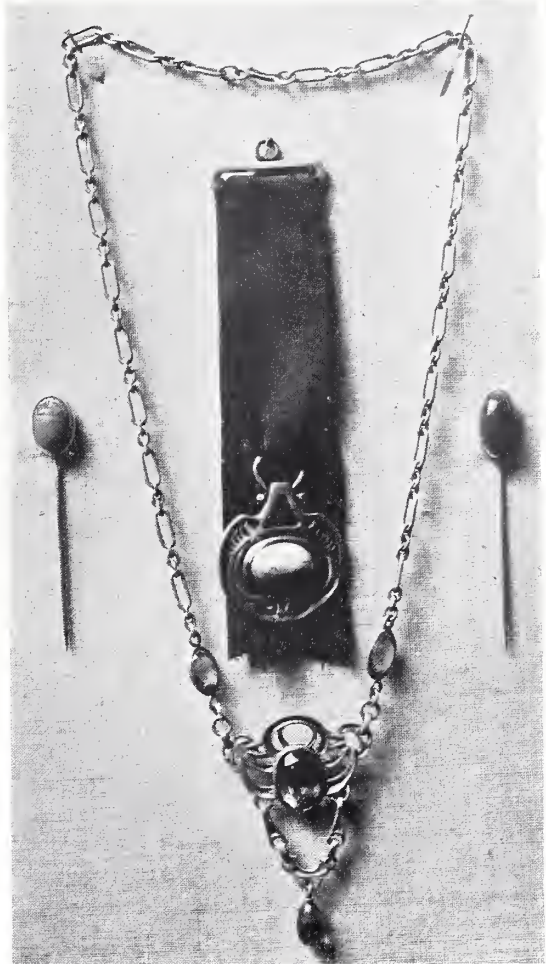

FOB, CHAIN AND PINS

BY MRS. FROEHLICH

## RECENT WORK BY MRS. HUGO FROEHLICH BY EVA LOVETT

RINGS and necklaces of excellent design and workmanship have lately been executed by Mrs. Hugo Froehlich, who is one of the four members of the first jewelry class graduated from Pratt Institute. Each of these young women, graduated five years ago, has attained skill and fame in her chosen work. A number of pieces of Mrs. Froehlich's jewelry are shown on this and the following pages.

For some time Mrs. Froehlich had a studio in New York, but she has lately moved her workshop into an upper room in her house at Richmond Hill, Long Island. Here she has established a quaint little studio, which is often filled with friends and admirers of her beautiful art, and where specimens



OXIDIZED SILVER CHAIN WITH  
TURQUOISE MATRIX

BY MRS. FROEHLICH

of her distinctive work are to be seen. Her workbench is located in front of a window which overlooks the pretty Long Island town. The tools of her craft lie conveniently about, and in mysterious little corner cupboards are kept articles necessary and dear to the craftsman.

As a member of the National Society of Craftsmen, as well as chairman of its jewelry department, Mrs. Froehlich had numerous articles in the jewelry case at the rooms of the society, No. 119 East Nineteenth Street, during its recent spring exhibition. Her brooches and necklaces were noticeable for their simple designs, their good form and artistic finish.

Among her pieces is a silver brooch of oval shape, the ends of the oval sharply pointed, and the sides more slightly so. The silver openwork around the central stone, which is turquoise matrix, is of an abstract pattern, with straight lines and square corners. A few plain lines, edging the openings, are the only decorations on the silver. A silver

ring, set with a pink opal, has a similar open pattern around the stone, while a heavier ring has a tourmaline, set solidly in silver, the length of the oval stone extending around the finger and into the broad finger band.

Several silver scarf-pins have round-edged broad settings, the stones used being azurite and opal matrix. One pin, set with a dark colored scarab, has short lines, suggestive of a feather, around the edge. One pin has a little crown across the top, giving it a delicate and light finish. Sleeve-links of jade and silver have a dainty little grooved edge around the jade.

Several fobs show handsome designs. In one a yellow-gray scarab has an hexagonal silver setting, which extends to points at the ends, which are finished with a small design of leaf-shaped points, overlapping. Around the flat

sides lines are used for decoration. Another fob has a turquoise matrix set in silver of an openwork abstract design, which has the lines of the pattern slightly curved.

Of three necklaces the heaviest is of oxidized silver, the large stone in the center and the smaller stones at the sides being of turquoise ma-



BROOCH AND  
RINGS

SILVER AND  
SEMI-PRECIOUS STONES

*Mrs. Hugo Froehlich*



SILVER  
CHAIN

WITH STAR  
TURQUOISE DROP

trix with curious yellow-gray markings. The central ornament is of open geometrical pattern, arranged in triangular shape, with the point turning down and the base of the triangle partly open. The chain has double links, separated by silver beads, the first two links fastened a short distance apart on the center piece, making a firm support, and small stones of the turquoise set where the links come together. A chain of smaller silver links is set with amethysts, the central ornament being a twist of silver links with a large amethyst in the middle, and a smaller stone dropping from a short loop of chain below it. A third silver necklace is of small square links separated at intervals by larger squares and broadening in front into an interlinked, graceful twist, which holds a turquoise drop.

Simplicity of design is a distinguishing feature of Mrs. Froehlich's work. Abstract patterns, arranged in simple forms, are seen among her pieces. The decorations are lines, long or short, separated, or in groups. Sometimes the chasing is

slight, the form of the article, and its adaptation to its purpose and to the stones which decorate it, making its artistic beauty.

Mrs. Froehlich is an admirer of the primitive forms of Indian work, with their simple decorations, and traces of her studies in this direction are to be found in her jewelry. She avoids alike the long, flowing, suggestive lines of the French nouveau, the elaborate, overworked nature forms of the realistic school, and the convoluted ornamental scrolls of the Renaissance period. Indian work, which is all symbolical, the smallest lines telling a story to whoever can read aright, furnishes a storehouse of designs of the most artistic and satisfying sort. The variations are infinite. If one understandingly adapts his design to his purpose, there is no monotony in the work.

Mrs. Froehlich has also done much work of the lighter and more delicate sort, for she does not believe in limiting herself to a single style or specializing strongly in one direction. And her work is of the well-finished kind, which makes the pieces pleasant to see and handle. The ornaments which come apart in the wearing, the stones which fall out, and the pins which come off are an abomination, she thinks. The piece may be ever so simply designed, but it must be completely and strongly finished. It is an ideal well worth working for.

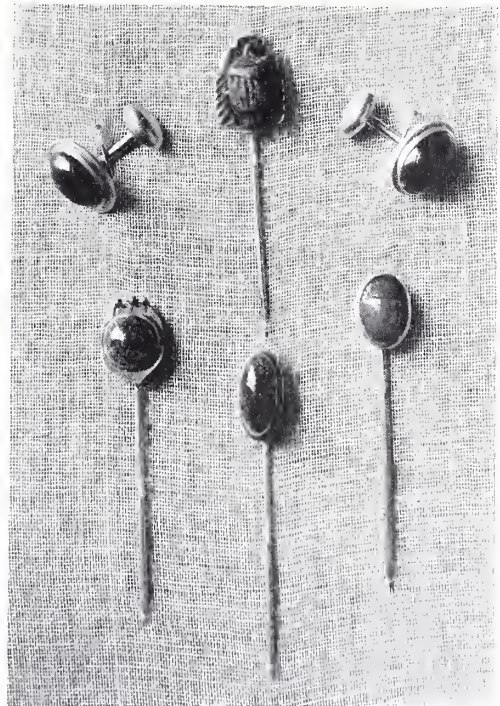

PINS AND LINKS

BY MRS. FROEHLICH

## Current Art Events

Her very large collection of semiprecious stones are beautiful to see in their wonderful variety of color, and the quantity of them makes the correct choice of a stone possible when there is an order to fill. Among them are abalone, the iridescent lining of the *Haliotis* found on the Pacific coast, and corals in many shades; green malachite, with strange colors straying through its greenness; azurites and lapis lazuli, both of deep blue; and chryscolla, of a bluish-green. Turquoise matrix, with its odd markings, comes from copper mines, and the topaz, opal and amethyst are found in Western mountains. Laboradite of a grayish blue, and Chi-

nese jade of a deep green; tourmalines, pink and green, and chrysoprase, mamomaline, and some beautifully marked transparent stones, called verisite (petrified wood), are found in the collection.

Among some recent orders now in process of construction by Mrs. Froehlich are pieces which show, in an interesting way, the variety in her work. Among these is a set of five gold rings left by the will of a grandmother to five grandsons. The rings were to be alike, of lapis lazuli; set in gold, and with a symbolical design. They have a broad gold setting, and on either side of the round blue stone there is chased on the widest part of the band a pair of wings, making the design the "Winged Globe" of ancient times. Another curious piece is a watch-fob designed for a woman who is a member of several clubs, and the long fob hanging over the ribbon has the symbols of five societies woven into its length. A silver belt buckle has an odd-shaped piece of abalone shell used in its decoration, and several bronze belt buckles of quaint designs are also in process of making.

Mrs. Froehlich has also done some good repousse work in copper and has several specimens in candlesticks, cassarole covers and other articles in her studio. During May, she had an exhibit of her work at Stamford, Conn., where she has taught classes.

## CURRENT ART EVENTS

THE statue of John William Mackay which we reproduce by special permission herewith will be unveiled with appropriate ceremonies at Reno, Nevada, early this month. Mr. Gutzon Borglum, the sculptor, has treated the subject with an admirable sense of its downright Americanism. Another recent piece of work from Mr. Borglum's studio is shown on this page. Mr. Borglum has received the commission for the equestrian statue of General Sheridan, to be erected in Sheridan Circle, Washington, D. C.

THE Gibbs-Channing-Avery portrait of Washington has been acquired by the Metropolitan Museum, New York. This painting, as Mr. Isham, who contributes an interesting article to the "Museum Bulletin" on the subject, points out, gives with admirable skill and truth an apparently more human and less idealized rendering of the sitter than the more famous Athenæum head.

PROFESSOR ARTHUR FAIRBANKS, of Michigan University, has been elected director of the Boston Museum of Fine Arts.



"THE MARTYR"

MARBLE STATUETTE  
BY GUTZON BORGLUM



JOHN WILLIAM MACKAY  
BY GUTZON BORGLUM



## Painting and Painters



Muther's "History of Modern Painting"

SOLITUDE

BY ALEXANDER HARRISON

### PAINTING AND PAINTERS

DR. RICHARD MUTHER has continued his "History of Modern Painting" to the end of the nineteenth century. The revised edition is brought out by E. P. Dutton & Co. in four volumes profusely illustrated with a creditable and comprehensive series of reproductions, and in addition some fifty full-page plates in color. The book remains the essential statement of its subject; the author's method, seeking not so much an appraisal of pure art as its interpretation in terms of controlling conditions, stands at the forefront of modern criticism; and persons having an intelligent curiosity about later-day painting who are not yet possessed of this work will be gratified to find it available in its present amplified and embellished form.

"The nineteenth century," says Dr. Muther, "not only shows a new age, but probably begins a new section of modern history. It is probable that in contrast with this epoch of stirring movement, during which the readjustment of all political and social relations, the new discoveries in the instruments of commerce, trade and industry, have given an entirely new aspect to the world, the next thousand years will sum up all the previous cen-

turies as the 'old world.' New men require a new art. One would be inclined to surmise from this that the art of the nineteenth century presented itself as something essentially personal, with a sharply distinctive style. Instead of this it offers at first view, in contrast with those old ages of uniform production, a condition like that of Babylon. The nineteenth century has no style—the phrase that has been so often quoted as to have become a commonplace. In architecture the forms of all the past ages live again. The day before yesterday we built Greek; yesterday, Gothic; here, Baroque; there, Japanese; but amidst all these products of imitative styles there rise up stations and market places which, with the robust elegance of their iron colonnades, herald the greatness of fresh conquests. In the province of painting there are similar extremes. In no other age have minds so diverse flourished side by side as Carstens and Goya, Cornelius and Corot, Ingres and Millet, Wiertz and Courbet, Rossetti and Manet. And the existing histories excite a belief that the nineteenth century is a chaos into which it is possible only for some later age to bring order."

It is with the specific purpose of correcting this, as it seems to him, mistaken or at least imperfect notion that the author sets out in this book to

## Painting and Painters



*The Century*

CLAUDE  
MONET

FROM MUTHER'S "HISTORY  
OF MODERN PAINTING"

define the distinction between the new growth and the repetition of the old, between the eclectic and the personal, the derived and the independent, and in so doing to solve the question, hitherto usually a begged question, as to what is the distinctive style of modern art, and what are the logic and sequence of its evolution.

A word as to the conclusions of his comprehensive and fascinating study. Modern art, says the Breslau professor, with its heartfelt devotion to every-day life and the mysteries of light, has an essentially Germanic character, finding its ancestors not in Raphael, Michaelangelo and Titian, but in the English of the eighteenth, the Dutch of the seventeenth and the Germans of the six-

teenth century. The Italians and Spaniards, whose entire intellectual culture rests upon a Latin foundation, find it difficult, therefore, to follow this change of taste. They either adhere to the old bombastic and theatrical painting of history or they recast the new painting in an external drawing-room art draped with gaudy tinsel. Even in France the rise of the new art meant, as it were, the victory of the Frankish element over the Gallic. Millet, the Norman; Courbet, the Frank; Bastien-Lepage, of Lorraine, drove back the Latins—Ingres and Couture, Cabanel and Bouguereau—just as in the eighteenth century the Netherlander, Watteau, broke the yoke of the rigid Latin classicism.

Mrs. L. M. Bryant tells the history of painting from early times to the present in her book, "Pictures and Their Painters." (John Lane Company.) She addresses herself to the needs of people too busy to give time to an exhaustive study and aims to afford a good grasp of the subject in limited space. In short, she supplies a popular interesting manual, the need for which she has met with in her abundant experience as a teacher. No pains

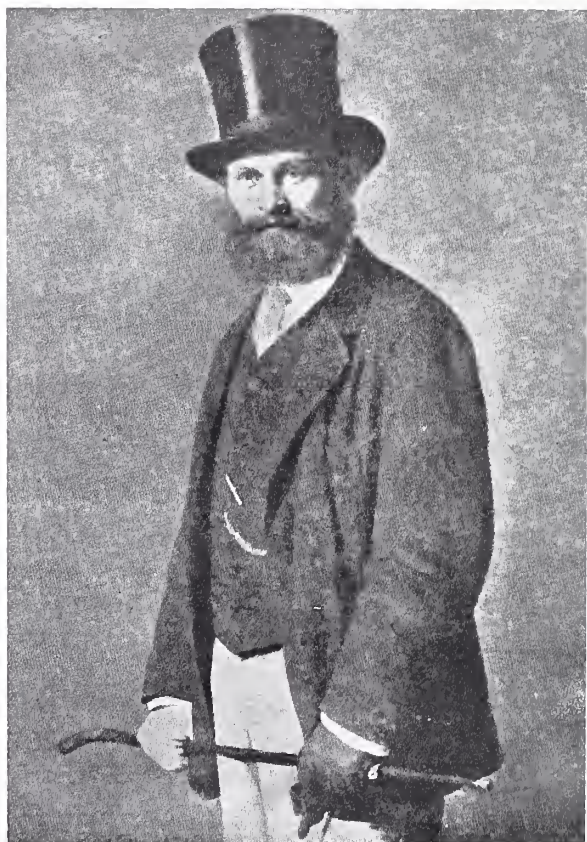

EDOUARD  
MANET

FROM MUTHER'S "HISTORY  
OF MODERN PAINTING"



## Painting and Painters

have been spared in keeping the text abreast of the latest results in attribution and research, and a similar endeavor has been made to present the best and most authentic photographic reproductions. The illustrations number over 300. In selecting photographs for illustration, the object has been not only to give the most characteristic examples of each artist's work, but those which would best illustrate the tendencies of the times which produced them or particular phases of history, legend or story.

T. Sturge Moore is often at outs with Mr. Benson and Signor Ricci and other writers on the subject in his interesting discussion of "Correggio." (Imported by Charles Scribner's Sons.) He finds these critics too much preoccupied with the Darwinian "theory of a common ancestor," and is frequently at pains to read the results of Correggio's art back to the artist rather than to influences. He questions both the methods and aims of modern historical art criticism, and in doing so, it must be confessed, gives the breath of freshness to his appreciation.

In the same series Miss Maud Cruttwell speaks ex cathedra on Antonio Pollaiuolo. The collaboration of the two brothers Piero and Antonio has led to one of those endless problems of attribution. The distribution of praise will probably never be made to the satisfaction of everybody between Beaumont and Fletcher. Here Miss Cruttwell solves the difficulty by awarding all the good to the superior artist, Antonio. The book is a special plea, but a scholarly and enthusiastic one.

Edgumbe Staley contributes the introduction to the excellent series of sixty-four plates in the volume on Fra Angelico in the Newnes Art Library. (Frederick Warne & Co.) The account is briefly and simply told, as befits its position in one of these attractive issues, which practically are bound portfolios. A List of Chief Works with descriptive details is appended.

For the volume on Giovanni Bellini in the same series the introduction is supplied by Everard Meynell. He refers to Isabella d'Este as "a prototype of the American millionairess who buys her pictures with no small share of good taste." The tale of her long negotiations for a painting of profane interest and her final disposal of the *Prasipio* in a bedroom is amusingly put. This, with an account of the contest with Titian, leaves a sense of personality. The *Madonna with Sleeping Child* is reproduced as frontispiece. A score of the *Madonnas* are included among the plates.

The second volume on Titian in the same series,

"The Later Work of Titian" (Frederick Warne & Co.) is devoted to works dating from 1540 onward. Probably no painter who practised to such an advanced age could be found to show such uniform power in his later period. The old patriarch's amazing retention of vigor and of skill makes such a selection as is here presented abundantly valuable. Henry Miles contributes the introduction. His inferences regarding Titian's advantage over Velasquez and Rembrandt are, in view of the painter's peculiar feminine type and the traditions of his sparing use of the model, rather novel.

In the same library, too, a recent issue is devoted to "The Pre-Raphaelite Brotherhood." Millais's *Autumn Leaves* serves a frontispiece. Holman Hunt, the only member of the group who kept steadfast to the accurate rendering of detail in after years, is represented by nine reproductions; Rossetti, by eighteen; Millais, sixteen; Ford Madox Brown, six; the original Italians, by nine. The introduction is by T. Ernest Pythian.



From Bryant's "Pictures and Their Painters"

PORTRAIT, BERLIN GALLERY

BY VELASQUEZ

## Painting and Painters



FROM BRYANT'S "PICTURES AND THEIR PAINTERS"  
THE TAILOR

BY GIOVANNI MORONI

Dr. Muther's brilliant analysis of Goya makes a noteworthy addition to the handy pocket-sized volumes of the Langham Series of Art Monographs. (Imported by Charles Scribner's Sons.) He draws the portrait of the Spaniard as the Man of the People in art during the revolutionary period, satirizing monarchy in the most monarchical country of Europe, impeaching clericalism and militarism, the one artist who stood up with the men of letters in the group of radicals, free from academic restriction, if, by the same token, somewhat lacking in culture and handing on the first impulse to our modern impressionism.

Whistler is treated in the same attractive series by Dr. H. W. Singer. Aside from the difficulty in dealing of Whistler's art which presents itself in the obstacle of an eccentric personality famous in two hemispheres, the book is well and wisely put. But, though the author realizes the critical prob-

lem and states it, the cantankerous side of Whistler's temper is too much for him. He attempts to assign it a function, Lombroso fashion, but only succeeds in rather clumsily obtruding it. The appreciation of the art leaves little to be desired.

Whistler is one of the subjects of the collection of Mr. Gallatin's essays in art criticism, published under the title, "Whistler: Notes and Footnotes and Other Memoranda." (John Lane Company.) Among the Whistler papers are "Whistler as a Man of Letters," "Whistler's Realism," "Memorial Exhibition, Boston, 1904," "On Certain Drawings by Whistler" "Whistler: Master of the Lithograph." Other papers discuss aspects of the art of Leonardo, Puvis de Chavannes, Beardsley, Everett Shinn, Childe Hassam, etc. Eight plates appear in illustration.

Three distinguished artists in one family, three brothers, notable in achievement and considerable in influence, "The Brothers Maris," are the subject of an extra number, edited by Charles Holme, of THE INTERNATIONAL STUDIO. Of the

seventy-three plates in illustration, eight are reproductions in facsimile colors, eight in photogravure, and one in lithographic process. Croal Thompson, who contributes the letter-press, ranks James Maris, technically the greatest of the three, with Velasquez and Franz Hals.

Sir William Beechey, one of the distinguished artists of the early English school, is the subject of a biographical appreciation by W. Roberts. (Imported by Charles Scribner's Sons.) Half a hundred portraits, from among his sixty years' output, are presented in illustration. The author's aim has been to write a chronicle of the artist's life and work and to describe his pictures rather than to estimate their value. The material is copious and is well arranged. Two of Beechey's private account books are reprinted in a supplementary chapter, and full index to names is furnished.

Lionel Cust has condensed his exhaustive study

## Painting and Painters

on the life and works of "Anthony Van Dyck," published in 1900, for inclusion in an abridged version in the series of "Great Masters in Painting and Sculpture." (Imported by Charles Scribner's Sons.) The opportunity has been used to add some new facts recently come to light. This useful and attractive book carries thirty-three illustrations, the self-portrait owned by the Duke of Grafton serving as frontispiece.

S. R. Winchell issues a directory certain to be useful in its field, the "Artists' Blue Book of Chicago." The names and addresses of artists of the vicinity are alphabetically arranged under several headings, which include architects, decorative designers, painters, sculptors, arts and crafts workers, illustrators, ceramic workers. Lists of art schools and societies are included. In all, the book comprises some 2,500 names.

Julia de Wolf Addison, who has already issued a similar account of the National Gallery, contributes to the Art Galleries of Europe series (L. C. Page and Company), a volume on the "Art of the Dresden Gallery." There are over fifty full-page illustrations. The book gives elaborate instructions for studying the collections, step by step, pointing out the things to see and how they are to be regarded. It is designed on the plan of a copious guide-book, enlivened by art, history and anecdote, by the way. The Italian, Spanish, French, English, Flemish, Dutch and German are taken up, room by room.

Albert F. Calvert is editing a series of books devoted to art in Spain, under the general title "The Spanish Series." (John Lane Company). Murillo is the subject of one of the first volumes now ready. The biographical appreciation is from the pen of the

editor. A list of works of the painter follows, with, in each case, a short description of the painting and an indication of where the original is preserved. Of the total, 165 are reproduced in illustration on special paper at the rear of the book.

Another volume in the series is devoted to "The Escorial." This is an historical and descriptive account of the Spanish Royal Palace, Monastery and Mausoleum. It carries 278 illustrations. The letter-press gives in condensed form a history of the founding and building of the edifice, deals in detail with the more interesting features of its architecture and describes the pictures, fresco paintings, illuminated missals and other works of art



SIXTUS IV.  
FROM THE TOMB

"ANTONIO POLLAIUOLO"  
BY MAUD CRUTTWELL



THE DESCENT  
FROM THE CROSS

"FRA ANGELICO"  
NEWNES ART LIBRARY

contained in the several portions of this great composite pile.

"Seville, an Historical and Descriptive Account of the 'Pearl of Andalusia,'" by Albert F. Calvert in the same series, carries 300 illustrations. The author discusses Moorish Seville, Seville under the Castilian kings, the Alcazar, the Cathedral, the old Roman City and various buildings of the fifteenth, sixteenth, seventeenth and eighteenth centuries, with a chapter on the painters of Seville, written in collaboration with C. Gasquoine Hartley. Alone among the ancient seats of Moorish dominion Seville maintains life and prosperity, a fact which renders the subject of this book doubly interesting.

A catalogue of the George A. Hearn Gift to the Metropolitan Museum of Art has been printed for the Museum in an appropriately handsome form. Prefaced to the catalogue appears the correspondence between Mr. Hearn and the president and trustees, with the offer of December, 1905, and the amended offer, to meet the wishes of the Museum, of January, 1906. The fifty-one pictures comprised in the munificent gift are reproduced with great care in half-tone and are faced in each case with a short biographical and iconographic note.

A report on the Noyes Collection of Japanese Prints, Drawings, etc., the gift of Mr. Crosby S. Noyes, of Washington, D. C., is reprinted from the report of the Librarian of Congress.

## *An American Village Bank*

**A**N AMERICAN VILLAGE BANK  
BY HENRY H. SAYLOR

IT IS seldom, indeed, that in the design of a small utilitarian building an American architect is allowed to break away from the traditional—the commonplace, I might almost say—and give free rein to his fancy. Perhaps, in the interest of harmony in sky lines, it is as well that this is so, and yet when one does find such a charming result of an unfettered imagination as Mr. Embury has given us in the little building for the Palisades Trust Company at Englewood, N. J., it is impossible to repress the wish for more of it.

As one looks at the architect's sketch elevation one can readily imagine the average bank officials' building committee throwing up its hands in horror at the mere thought of investing money in a design so utterly at variance with all their preconceived ideas of how a village bank should appear. Fortunately, however, in this case, the committee was carried away by the very unusualness of the architect's suggestion. They realized at once that such a building could not fail to evoke comment. Were that comment favorable or unfavorable, it would be plentifully made. Every passer-by could not help noticing the building. Whether in his opinion the bank was a success or a failure, it would be talked of, and that meant business for the owners. So it was

not with fear and trepidation that the design was executed, practically as originally drawn, but rather with a purpose as well as an appreciation.

Englewood itself is one of the most charming of the New York suburbs. A village rich in trees it is—great arching elms and oaks, most of them—requiring that the buildings they shelter shall be low in contrast. The bank has a conspicuous location directly across the village green from the railroad station, so that its position, as well as its form, brings it constantly to the attention of practically everybody in the village.

A sharp contrast of color in the materials accents the bank's distinction in form. The base and piers are built of a cream-white local sandstone, laid in natural cement mortar. Chestnut is used for the



PALISADES TRUST AND GUARANTY COMPANY  
ENTRANCE

AYMAR EMBURY, 2D  
ARCHITECT

## An American Village Bank

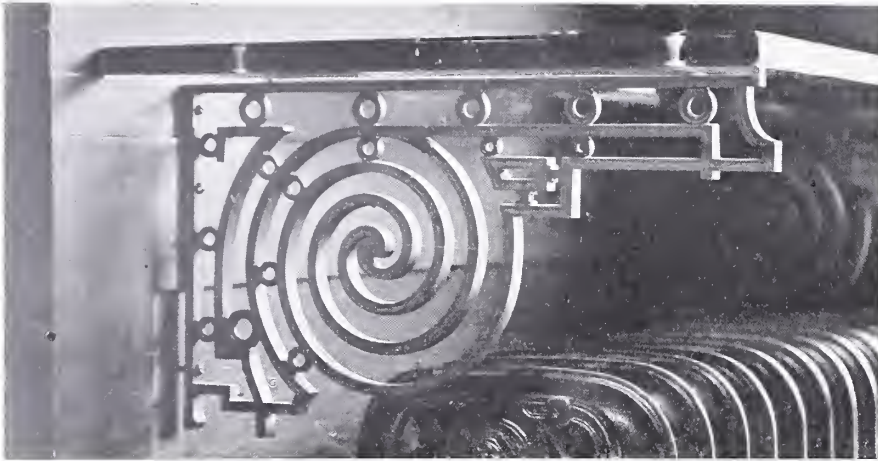

not appeal must surely feel the charm and quaint dignity of the interior. The counting-room opens up spaciouly to a ceiling whose buff, sand-finished plaster is relieved by heavy beams of red oak. The screen walls, shutting off

BRACKET

BY AYMAR EMBURY, 2D

window mullions, sash and half-timber work up under the eaves, creosoted with a dark green stain. The windows are divided into small panes by wide leads. A band of red brick, laid in a herring-bone pattern, with green and white terra-cotta inserts, marks the line of the second floor and contrasts beautifully with the sandstone and the woodwork. Consistent with the interior, this band is not carried across the middle portion of the building, where the counting-room extends unbroken from the first floor to the roof. The line of color is strengthened by brick inserts in the stone piers and by panels of terra-cotta, in buff, white and green, set into the wall piers flanking the entrance. For the roof a red tile was the only possible choice. Instead of the usual S-shaped tiles, which the architect felt would give a texture too rough and too large in scale, a flatter tile is used—that known as the “French A-shaped.” Shadowed by the heavy overhang of the eaves, the intricate half-timber work is felt to be in the best possible position, lending a depth and brilliance to the shadows, which could hardly be otherwise obtained. Solid timbers carried through masonry piers is a favorite motif of Mr. Embury’s, and one that he has employed effectively in other work. Its function here is to support a simple bronze arc-lamp from each of the four pylons. Unfortunately, these had not yet been hung when the pictures were made.

At the middle of the front elevation the interest centers on the main entrance. Its low, tiled hood roof rests on the chestnut beams that are carried through the masonry. Brick and leaded glass connect the piers to the main wall, and brick nogging fills the gable end over the lintel.

Retaining for its own use a part of the basement for vault storage space, the bank leases the remaining space therein for three offices. The main floor is divided as indicated in the plan that is here reproduced. It provides for a large, well-lighted, and well-ventilated working space, most of which is open to the second story ceiling, and for three rooms for bank officers and depositors. The vaults and janitor’s quarters are at the rear.

Once inside the bank proper, even those to whom the exterior does

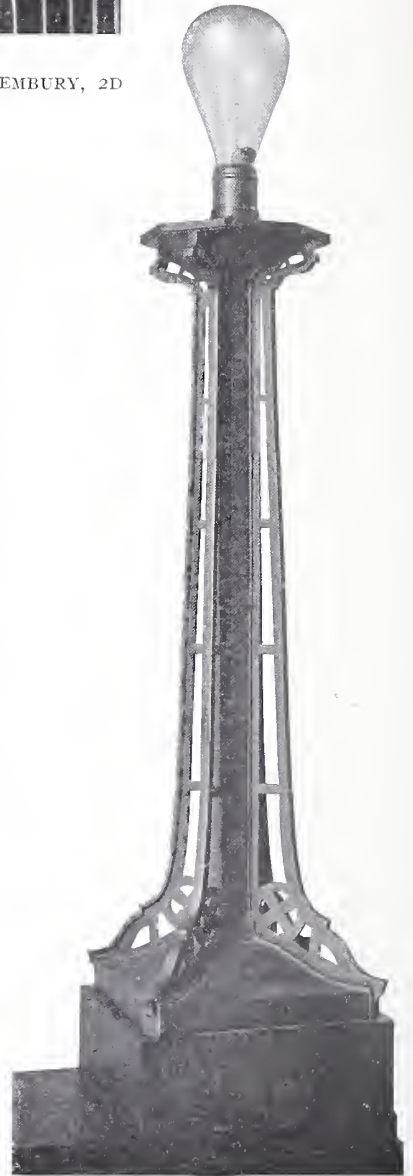

LAMP  
STANDARD

BY AYMAR  
EMBURY, 2D

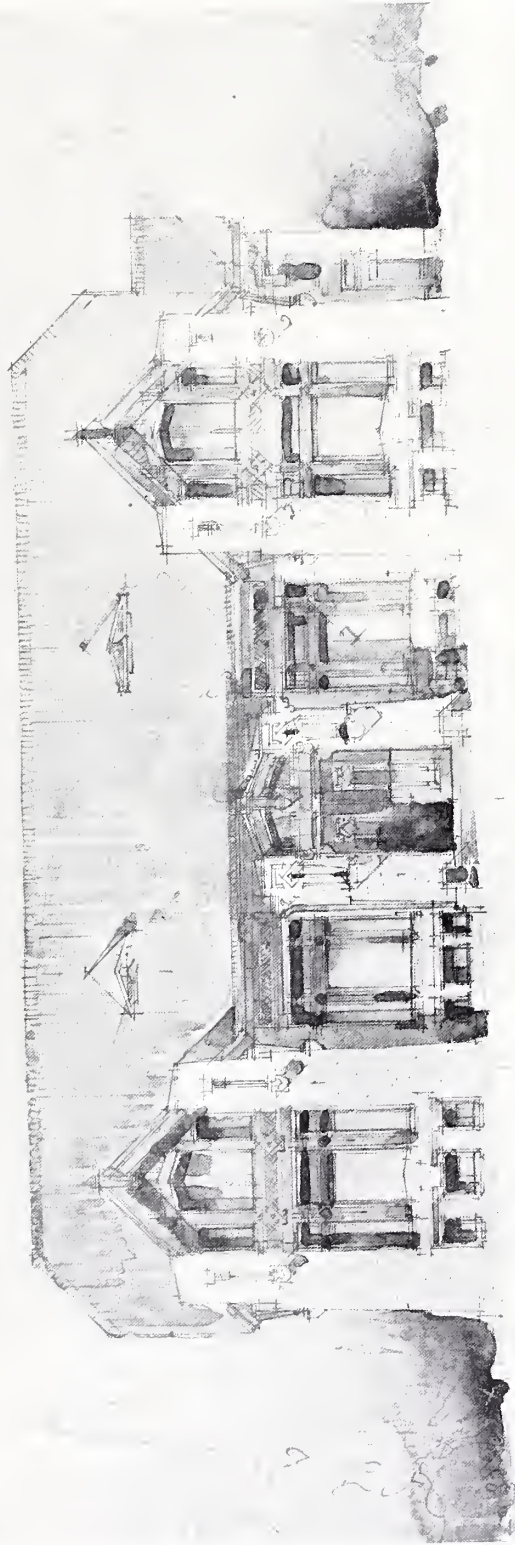

SKETCH  
PALISADES TRUST AND  
GUARANTY COMPANY  
ENGLEWOOD, NEW JERSEY  
AYMUR EMBURY, 2D

## *An American Village Bank*



PUBLIC SPACE  
ENGLEWOOD BANK

AYMAR EMBURY, 2D  
ARCHITECT

the directors' room and the janitor's apartments above, are of similar plaster-and-timber construction. On all sides there is a feeling of openness, gained by the use of many windows and by glass, simply leaded, in the partitions. An inlaid band of silver panels the counterscreen and partition posts—an unusual use of materials that accents the beautiful grain of the oak as no moldings could possibly do it. The same material is used for the simple letters indicating the tellers' and cashier's windows and the doors leading from the public space. The grille in the counter screen is of bronze in a dark finish, the high lights polished brightly, leaving the background a verde antique. Behind it is a remov-

able glass screen, the lower part of which is ground to serve as a shield in place of the usual low curtains of silk.

It is in the light standards on screen and newels, and in the side wall brackets and ceiling globes, that the architect has added the final touches to the bank's distinctive character. The standards, particularly, show forth the same quality of individuality—the same independence of the conventional without being bizarre—that distinguishes the exterior.

An elaborate vault system has been incorporated into the building between the working space and the janitor's quarters. In the basement and first



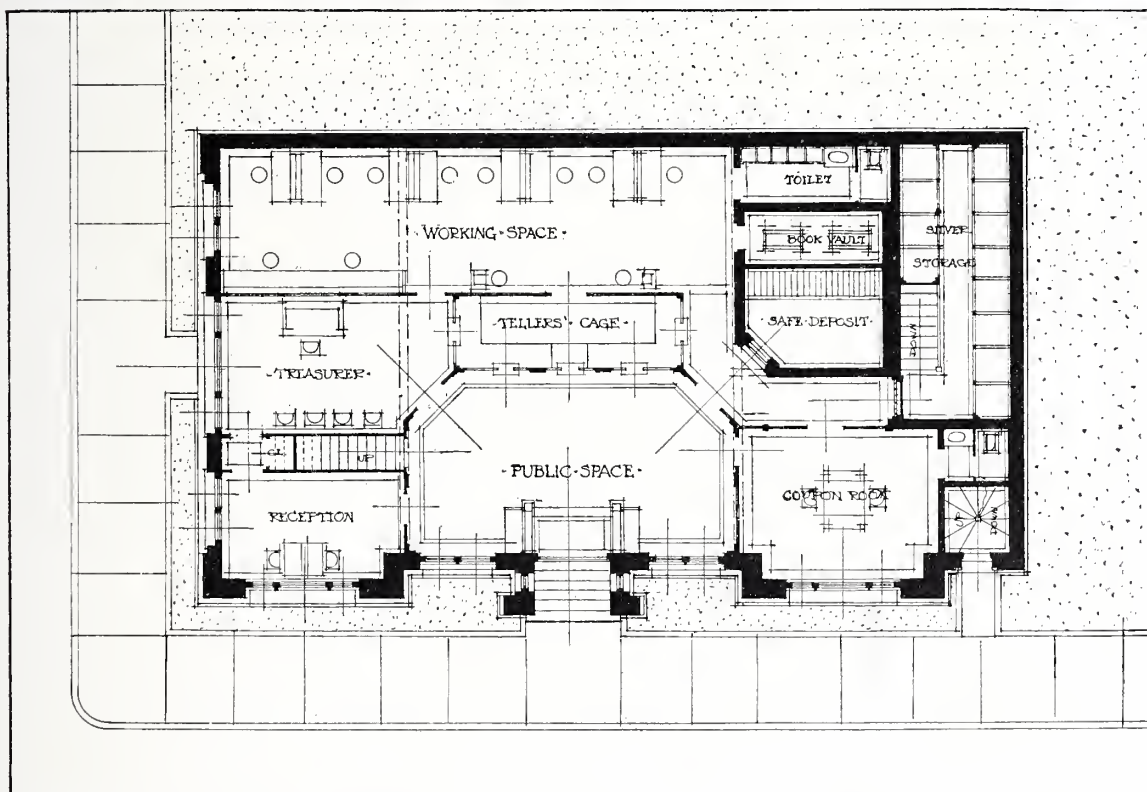
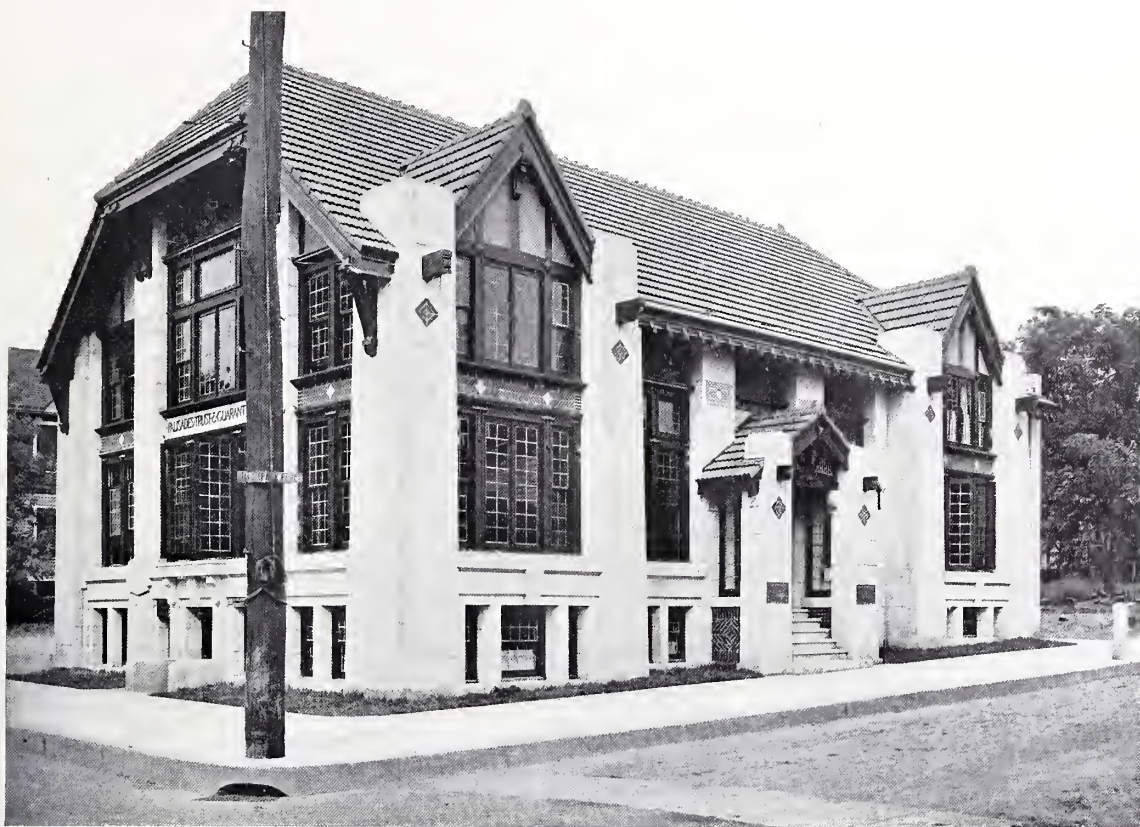

EXTERIOR  
AND PLAN

PALISADES TRUST COMPANY  
AYMAR EMBURY, 2D, ARCHITECT

## *An American Village Bank*

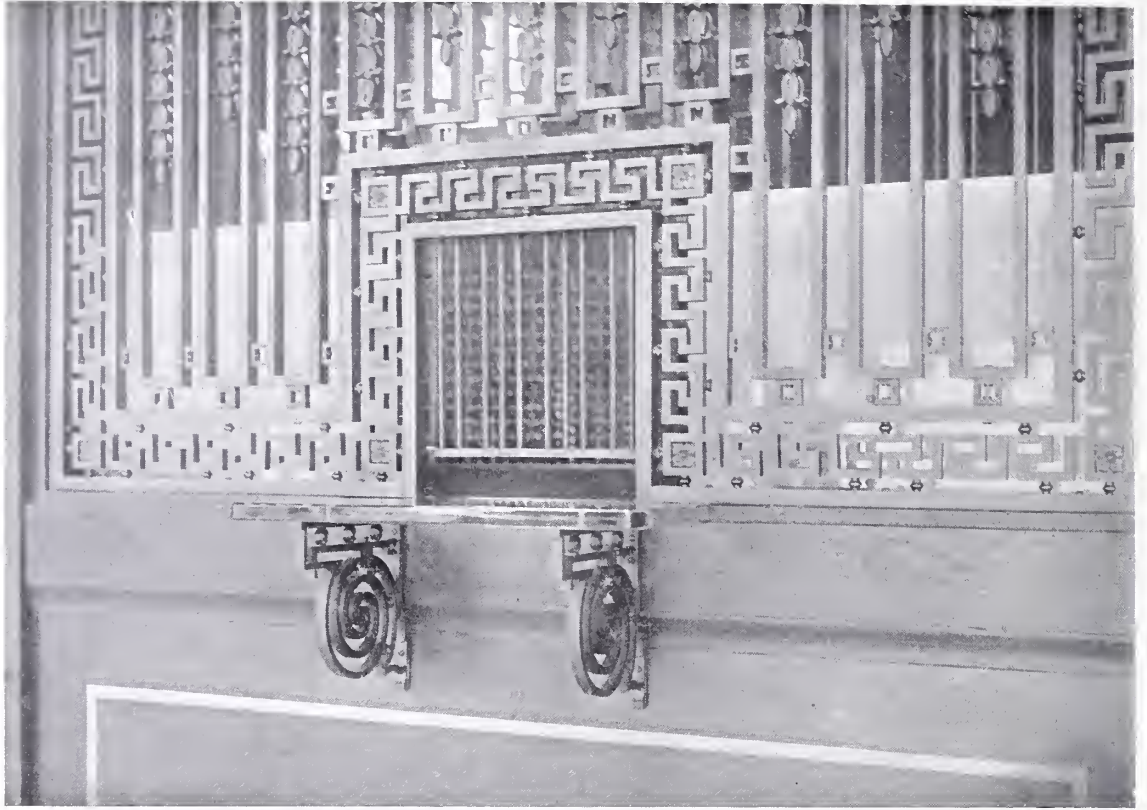

DETAIL OF SCREEN

BY AYMAR EMBURY, 2D

story are vaults for silver storage, while on the main floor there is a fire-and-burglar-proof vault for safe deposit and an adjoining book vault. The outside of the safe deposit and book vaults is sheathed by plates of steel, blued and polished. Bronze plate, beautifully machined, is used for the bolts and lock fittings on the massive doors.

Upstairs the directors' room is wainscoted and beamed with red oak over the rough buff plaster. In the triangular wall spaces at the ends of the room there are to be two mural paintings, commemorative of Hendrik Hudson's first sight of the Palisades.

I am not going to claim for Mr. Embury's bank an affiliation with any recognized architectural style. There is in it a strong suggestion of the best modern German work, and the design is tempered by a touch of the picturesque English domestic feeling. I think no one would refuse to recognize in the building, however, a quality that is distinctly American, and that, moreover, belongs to the American village. One does not feel in the least a striving for an effect; the building is a thoroughly straightforward—albeit intensely imaginative—

development of its plan along purely structural lines. As such it is good architecture and we would do well to have more such work to enjoy.

THE forthcoming issues of *THE INTERNATIONAL STUDIO* will contain a fully illustrated article on the practical aspects of bookbinding, giving a full and comprehensive exposition of the processes employed. The article has been written by Dr. Morris Lee King, a distinguished amateur in this art craft. Dr. King, whose own work has won high praise, is not interested in the craft either as an instructor or as a competitor with professional craftsmen, but has the advancement of the craft in this country thoroughly at heart. We have from time to time received letters from persons in various parts of the country who desired to take up the work of bookbinding with earnest artistic effort, but who found no competent teacher within reach and failed to find the books existing on the subject sufficiently clear to be intelligently helpful. Special pains have been taken by Dr. King in his article and illustrations not to leave essential points unexplained, and to give the fullest practical information.





"MOONLIGHT AT FLORENCE." FROM THE WATER-COLOUR DRAWING BY ROBERT W. LITTLE, R.W.S.  
*(In the possession of Frankfort Hollandt, Esq.)*

**R**OBERT W. LITTLE, R.W.S. A  
REVIEW OF HIS WORK. BY  
A. LYS BALDRY.

SOME interesting evidence of the way in which early associations help to determine the direction of an artist's effort in after life is to be obtained from the record of Mr. Robert Little's career. He takes rank among modern painters as a particularly sensitive exponent of the decorative side of nature and as a close student of the subtleties of pictorial design; and he has an exceptional power of seizing upon just those aspects of nature which lend themselves best to rhythmical arrangement and carefully balanced composition. He is, too, a colourist of much distinction, with a true appreciation of colour values and a love of sumptuous effects which is kept always within correct limits by an admirably cultivated taste. These qualities of his art are so definite and so characteristically displayed in everything he produces that clearly they come from a

very deep conviction and express an æsthetic belief which has determined the whole direction of his development.

It can safely be said that the foundations of this belief were laid during the first fifteen or sixteen years of his life, which were spent in surroundings well calculated to foster a permanent love of nature and an enduring preference for her stately graces rather than for her mere prettinesses. He was born at Greenock, on the Clyde, and the house in which his parents lived had a particularly pleasant situation outside the town and shut in by trees through which there was a charming vista of landscape leading away to the distant river and backed up by hills. In this house he remained until he reached the age of thirteen, and to this day he retains a vivid recollection of the impression made upon him by the beauty of the country round about his home. Even at this early age he found keen pleasure in simple contact with nature, in wandering through green fields and shaded woods, and in lying in the



"SHARDELOES"

*(By permission of Miss McGhee)*

BY ROBERT W. LITTLE

*Robert W. Little, R.W.S.*

long grass where he would see nothing but the blue sky overhead.

Between thirteen and sixteen he added greatly to his store of impressions, for he passed most of his time during these three years on the Gareloch, among rugged and romantic scenery, which fascinated him by its grandeur. In this land of gorgeous sunsets and wonderful effects of atmosphere he found much to stimulate his imagination, much that helped to develop his sense of colour and his understanding of qualities of tone; but he found also a vast number of suggestions as to the way in which what may be called the design of landscape should be treated. He began to realise in this district, with its lofty hills and large expanses of distance, the necessity for right pictorial construction in the representation of nature's beauties; and he was shown by a wealth of significant examples how much the romantic sentiment of an impressive scene depends upon the right relation of the forms and masses by which the landscape is built up.

It was at this period, too, that he began to feel the desire for production, the wish not merely to observe but also to record the results of his observations. He had already, while at school at

Greenock, had some lessons in water-colour painting and by sketching out-of-doors he sought to put to a practical test what knowledge he had acquired of the mechanism of art. But, beyond these tentative essays, he did little in the way of regular study until, in his sixteenth year, he went to Edinburgh and in the intervals of his ordinary school work attended the evening classes at the school of art on the Mound. Then came an interval during which he had very limited opportunities of satisfying his artistic inclinations; after a winter at the Glasgow University he went into his father's office with the idea of following a business career—in a shipping concern which had been founded by his grandfather.

However, he quickly discovered that he had not the temperament needed for the business life, and that he was wasting his energies in a wholly uncongenial occupation. So, at the age of twenty-two he made up his mind to abandon the office—after much anxious consideration—and to take what chances the future might bring him in the artistic profession. The first necessary step was to go through that systematic training in technical practice which he had not been able to obtain in his



“MASSA-CARRARA: SUNSHINE IN WINTER”

BY ROBERT W. LITTLE



"ON THE BANKS OF THE TIBER." FROM THE WATER-COLOUR DRAWING BY ROBERT W. LITTLE, R.W.S.  
*(By permission of Lady Darling.)*





*Robert W. Little, R.W.S.*

boyhood ; he went accordingly to the school of art in Edinburgh in which he had worked for a brief period some seven years before, and in due course passed from there into the schools of the Royal Scottish Academy to study from the life. So rapid was his progress with proper teaching and the right kind of opportunities that in less than two years he began to show his pictures in the exhibitions of the Royal Scottish Academy and the Glasgow Institute : plain proof that he knew how to make the most of his chances of acquiring the needful command over executive details. No doubt he was helped by the more or less desultory work he had done when as a boy he struggled to solve nature's secrets ; his efforts then had, it can well be imagined, taught him what were the deficiencies in his knowledge which were most likely to hamper him in his attempts at pictorial expression ; but certainly he deserves credit for having in so short a time gained a place among men of recognised ability.

His first exhibited paintings were mostly studies of interiors and groups of flowers, but his choice of subjects of this type was not due to any diminution in his love of landscape. Indeed, even during his student days he gave much time to out-of-door work, and among other wanderings in search of

material that pleased him he went on a sketching tour to Venice and North Italy, from which he returned with a number of excellent drawings. In 1882 he spent a winter in Rome, where he painted several important water-colours, such as *The Janiculum Hill from Tasso's Garden* and *Rome from the Aventine*, which rank among the chief of his earlier successes. The next four years he passed chiefly in Edinburgh, working from the material he had collected abroad, but in 1886 he stayed for some while in Paris, and, with a quite commendable desire to obtain a more complete mastery over his craft, became a student again, under MM. Courtois and Dagnan-Bouveret. Then he came back to Scotland and for another four years devoted himself to landscape, choosing as his sketching-ground the counties of Fife and Kinross.

Into this period come not only many of his most successful water-colours but also several oil paintings like *Vespers*, *Natural Enemies*, and *The Old Clock*, the last of which, when it was exhibited at the Royal Scottish Academy in 1889, brought him many congratulations from the president, Sir Daniel Macnee, and from other men well qualified to express an opinion. As further proof of his growing reputation, it may also be noted that in



“THE CLYDE FROM GLENAN”

(By permission of W. E. Horne, Esq.)

BY ROBERT W. LITTLE

*Robert W. Little, R.W.S.*

1886 he was elected a member of the Royal Scottish Society of Painters in Water-Colours. Indeed, by 1890 he had established himself as one of the ablest of the younger Scottish artists, and had received a full measure of recognition as a painter with more than ordinary originality and sense of style.

In 1890 he took up his abode in London, and by his contributions to the Royal Academy and the Royal Institute, and especially by the work he showed in the exhibition of the Royal Scottish Society of Painters in Water-Colours, held at Messrs. Dowdeswell's Gallery in 1891, gained immediate attention. One of the paintings he had in this last show, a figure subject, *Firelight and Twilight*, he sent, with some landscapes as well, to support his candidature for the Associateship of the Royal Society of Painters in Water-Colours in 1892, and these proofs of his powers secured his immediate election. He was advanced to full membership, it may be noted here, in 1899.

For some six or seven years after his admission to the "Old Society," the majority of the works he exhibited were figure paintings, delicately studied and daintily executed, which never failed to gain the approval of lovers of exquisite achievement. But latterly he has occupied himself almost exclusively with landscape, and has shown more and more definitely, as time has gone on, how logically and sincerely he can present those aspects of nature which, from his youth upwards, have seemed to him to be fittest for study and worthiest of record. Among his later works which have appeared in the gallery of the "Old Society" are such distinguished productions as the romantic landscape, *A Jacobite Gathering* (1901), *From Criffel to Allonby* (1903), *Rising Storm on the Solway* and *The Clyde from Glenan* (both in 1904), *Watford from Hamper Mill* (1905), *Shardeloes* (1906), and *The Golden Gap* (1907); as well as his *Massa Carrara: Sunset in Winter* which, with a number of other admirable performances, was



"RISING STORM ON THE SOLWAY"

(By permission of C. Plumtre Johnson, Esq.)

BY ROBERT W. LITTLE



"THE TUDOR WINDOW SEAT"  
BY ROBERT W. LITTLE

*(By permission of W. J. McLean, Esq.)*

*Robert W. Little, R.W.S.*

included in the excellent show of his work held in the earlier months of this year in the galleries of the Fine Art Society. Practically the only memorable figure subject he has shown since 1900 is the interior *The Tudor Window Seat*, which he sent to the "Old Society" in 1905.

In reverting to landscape he has, after all, only fulfilled his artistic destiny. Clever painter as he is of figure subjects, he does not find in them quite the same scope which is afforded him by open-air motives for the exercise of his remarkable individuality. But in landscape he takes a direction which leads him surely to results that are of the greatest possible interest as revelations of his manner of regarding nature, and as demonstrations of his preference for her most romantic aspects. One great merit of his work is that in following this direction he never allows himself to be led into any extravagance of expression. His romanticism is free from the taint of theatrical exaggeration, and the decorative qualities of his art are not spoiled by conventional limitations. The distinctive character of his performance is frankly a reflection of his personality, and comes from the habit of mind which

has guided the whole of his development and determined his choice of material throughout his life.

But this habit of mind is just what might have been looked for in a man brought up, as Mr. Little was, among impressive and romantic scenery. By the associations of his Scottish home, by the visits he paid to Italy during his boyhood and early manhood, he learned almost unconsciously to see nature largely and with a sense of her grandeur, to understand her vast simplicity, and not, by attending too closely to her infinite complexity of detail, to overlook the greater facts of her teaching. Upon these associations he has built up a system of practice which is more than commonly complete, and which serves him perfectly whatever may be the demands he makes upon it. It can be applied with equal appropriateness to such a piece of fantasy as *The Red Cross Knight*, and to such a frank and direct record of something seen as the quiet landscape *Shardeloes*; it is equally accountable for the decorative robustness of the *Rising Storm on the Solway*, for the repose and subtlety of *The Clyde from Glenan*, and for the studied elegance of the Italian scenes *On the Tiber* and *Massa Carrara*;



"FROM CRIFFEL TO ALLONBY"

(By permission of C. Plumtre Johnson, Esq.)

BY ROBERT W. LITTLE



"THE RED CROSS KNIGHT"

(By permission of Dr. W. J. Little)

BY ROBERT W. LITTLE

and it gives conviction and meaning to such definitely contrasted subjects as the *Moonlight at Florence*, and *From Criffel to Allonby*. It is, in fact, the only system by which an artist of Mr. Little's temperament could hope to do justice to himself, for it is a creation of his own, and has been added to and perfected by the promptings of his own intelligence.

In one sense it would be right to speak of him as a self-taught artist. He had his share of art-school drilling; he added to his experiences by study in French studios; but these educational opportunities came to him sufficiently late in life to leave his original convictions practically untouched. What he learned from his masters was not so much what he was to do, but how to carry out efficiently the artistic intentions which were already formed in his mind—how to overcome those mechanical deficiencies which confound the half-trained artist and condemn him to inexpressiveness. That he acquired all that he needed is evident enough in Mr. Little's work to-day; there is no hint of indecision in his art.

A. L. B.

## THE RUMOURED DISBANDMENT OF THE ARTS & CRAFTS SOCIETY.

LETTER FROM MR. WALTER CRANE.

To the Editor of THE STUDIO.

SIR,—As president of the Arts and Crafts Exhibition Society, will you allow me to contradict in your influential paper an entirely erroneous and unfounded report, which I regret to find has obtained some currency, that our Society has been "disbanded."

So far is this from the truth that we are a stronger band than before, having elected many new members since our last Exhibition in 1906, and we are now, according to triennial custom, contemplating our next show, which we hope to open in the autumn of 1908.

As the false report I have mentioned is calculated to be injurious to our Society, I shall be much obliged if you can give space to this official contradiction.

I am, Sir,

1 Hare Court,  
Temple, E.C.

Yours faithfully,  
WALTER CRANE.

# LEAVES FROM THE SKETCH-BOOK OF W. H. CHARLTON

**G**ENUINE talent is displayed in the sketches by Mr. W. H. Charlton represented here. An artist with a remarkable gift for depicting his surroundings in a manner simple and unaffected, his work possesses a charm of quality and an air of distinction which please the eye and satisfy the artistic sense. In these chalk and pencil drawings he combines freedom of execution with a sensitiveness of line, showing complete mastery of his medium and due appreciation of its limits. And it is through a medium like that employed here that Mr. Charlton is best able to express himself, for the decision and vigour necessary to attain a successful result thereby form the most characteristic features of his art. His most notable drawings are those which have been executed rapidly, for his observation is true, and he is able to render his subjects

with unusual facility. He has, moreover, a keen and ready appreciation of the decorative arrangement of his compositions. In the coloured chalk drawing, of which a facsimile reproduction is given, the artist has again obtained his effect by simple and direct means. He has blended his colours with remarkable skill, producing an impression at once satisfying and agreeable.

It is interesting to note that Mr. Charlton became a student of art comparatively late in life. Receiving a limited amount of training in Paris, first in the atelier of M. Rollin and later under M. Chartran, he has relied to a great extent upon his own artistic instincts and a close and intelligent study of the drawings of the old masters, with the result that his individual talent has been allowed to develop free from those restraints which so often accompany the training of a younger artist.



Montreuil sur Mer  
France



"CANAL SCENE, QUIMPERLÉ." FROM A CHALK DRAWING BY W. H. CHARLTON.







"TOUR D'HORLOGE, DINAN." FROM A  
PENCIL DRAWING BY W. H. CHARLTON

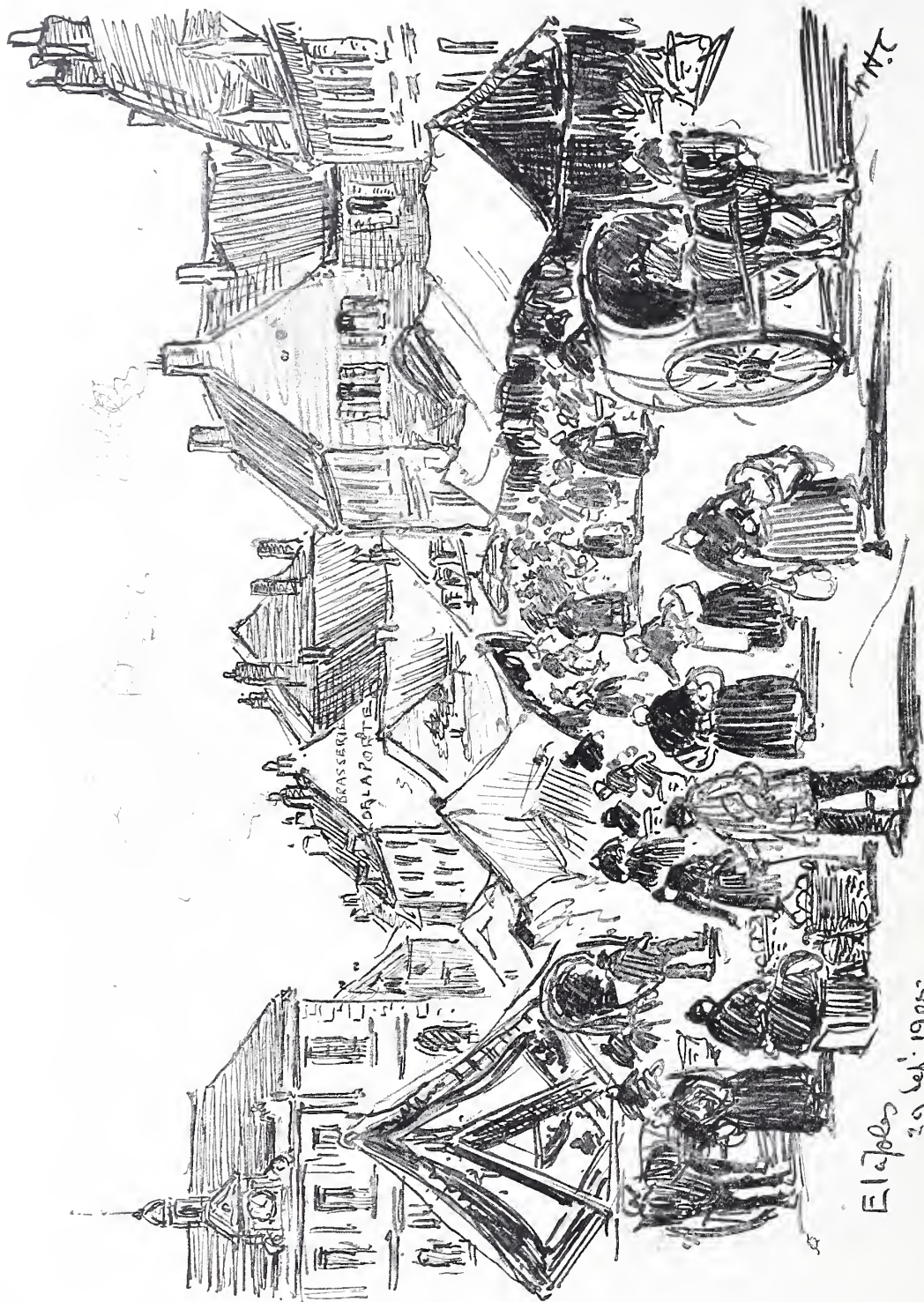

Etaples  
29 Sept 1905.

"ÉTAPLES," FROM A DRAWING IN  
INK AND PENCIL BY W. H. CHARLTON



Concarneau  
9 Aug 1906.

"CONCARNEAU," FROM A PENCIL  
DRAWING BY W. H. CHARLTON

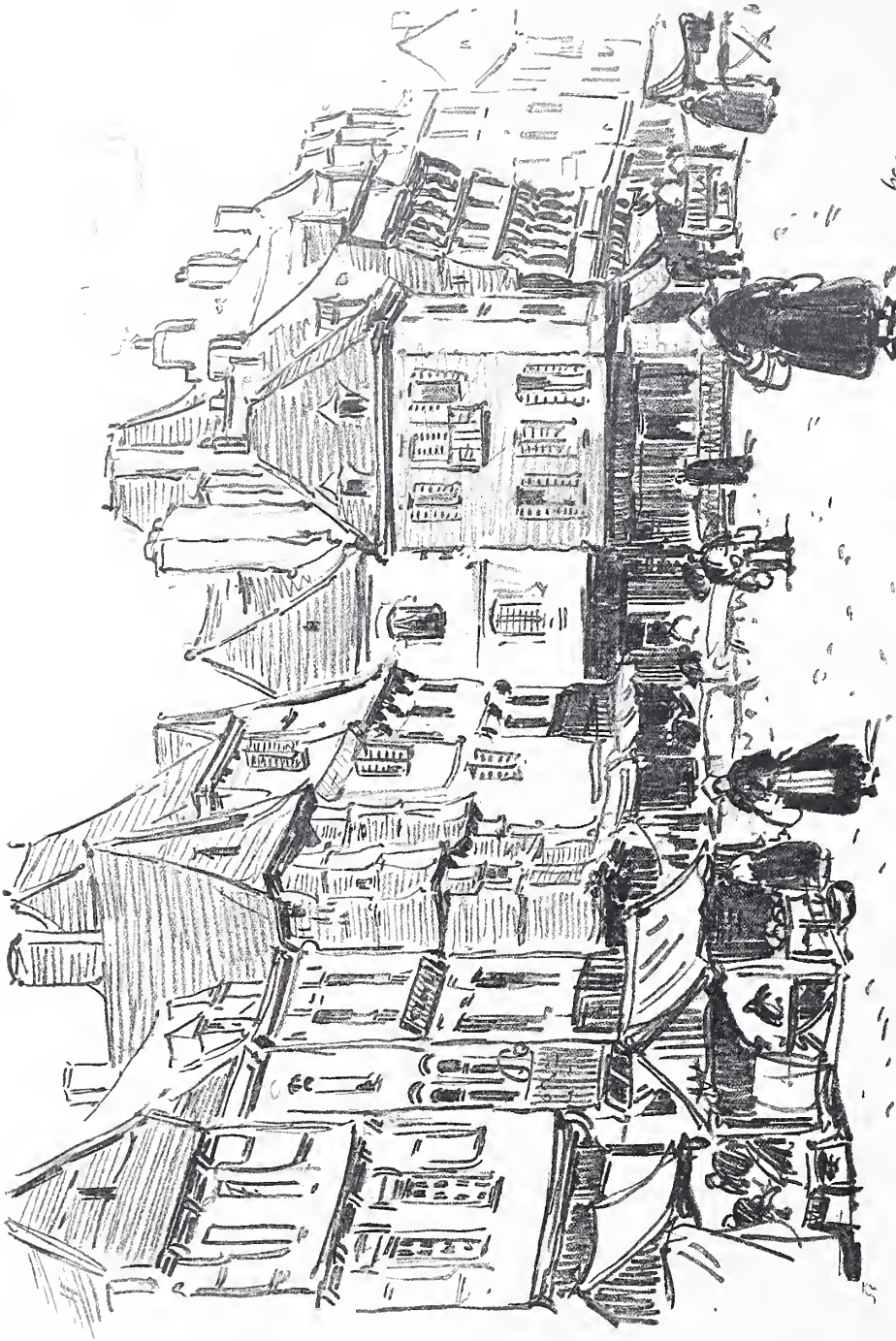

W.H.C.  
2 July 1908.

Lannion  
France.

"LANNION." FROM A PENCIL  
DRAWING BY W. H. CHARLTON

## The Mannheim Tercentenary Exhibition

### THE MANNHEIM TERCENTENARY EXHIBITION.

THIS exhibition is a combination of painting, sculpture, domestic architecture and æsthetic garden construction, admirably carried out by a committee working with a mutual aim, and who have also avoided the danger of being too extreme. A large portion of the buildings are to remain as permanent picture galleries, and this has warranted the use of costly materials in their construction.

The entrance hall, staircase and walls are of dark marble, the massive columns of a light striated variety, the doors, wickets and ornaments are of polished and beaten brass. The vestibule is a little dark, but rich in tone, and is relieved by spaces through which one gets glimpses of the large hall with its soft warm ivory colour shading into gold towards the ceiling nearly a hundred feet above. It is fitting that the largest canvases are placed here, the biggest among them being Melville's enormous sketch, *The Return from the Crucifixion*, faced by Egger-Lienz's *Peasant Pilgrims*.

It is becoming more and more a recognised fact that a picture in the process of creation is strongly influenced by its surroundings, and when finished depends for its effects fully as much on its environment as on its intrinsic beauty; it must be in unison and harmony with its *entourage*. In Mannheim, Professor Dill and his colleagues have succeeded in placing together those works which, quite irrespective of nationality, form a colour scheme in complete harmony with each other and the room in which they are hung. Moreover, the larger halls are divided into cabinets by projecting divisions, and these are seldom larger than an ordinary living room, but each compartment is separated from the influence of the next, and is complete in itself. At the same time the screens do not project so far, nor are they so high as to destroy the impression of the whole flower of which they are the petals. Nearly all the rooms are lit from the top, and the walls are hung with delicate silk, linen, coarse jute or other stuffs, the result producing variety of surface as well as of colour. To ensure the right *milieu* some rooms have been decorated by the artists themselves. One by Benno Becker is hung in black

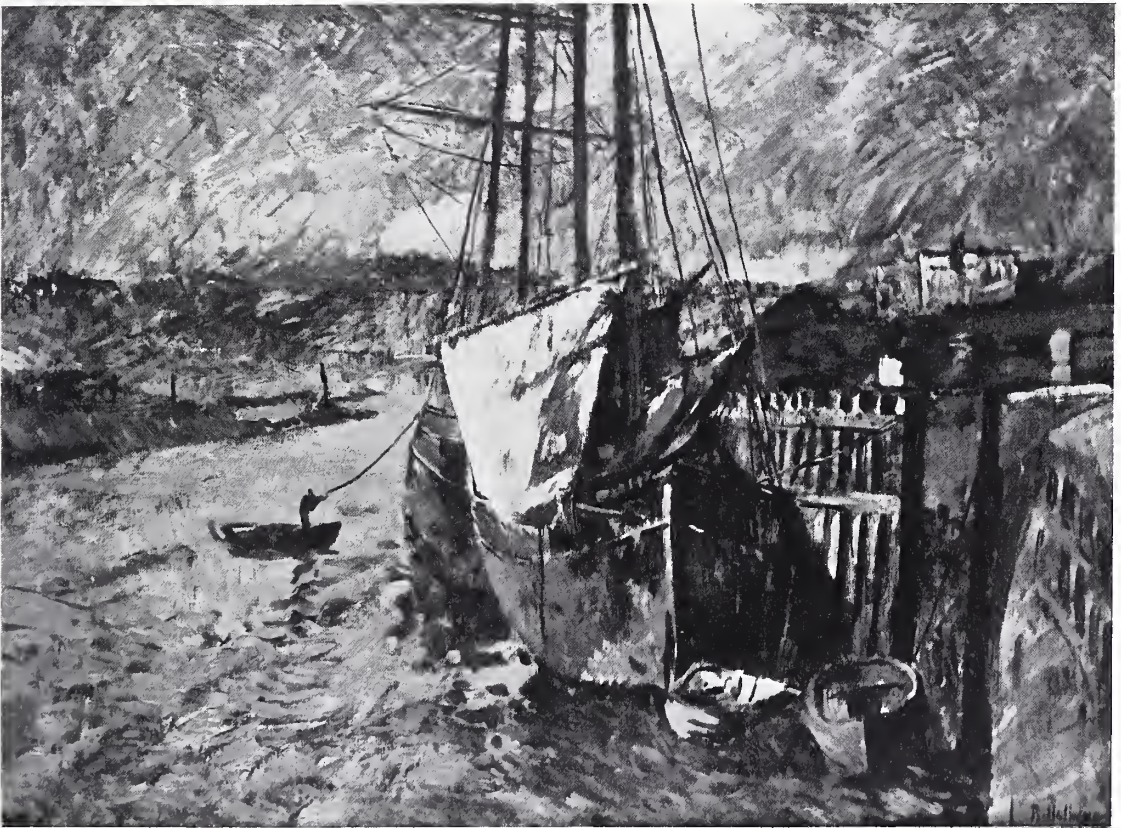

“THE WHITE SAIL”

BY PROF. R. HELLWAG



“WORKMEN'S BOATS, HAMBURG HARBOUR”  
BY PROFESSOR F. KALLMORGEN

*The Mannheim Tercentenary Exhibition*



“HESSIAN PEASANTS”

BY KARL BANTZER

figured brocade, the furniture, cabinets, etc., being ebony, while the broad decorated cornice and ceiling are gold. In contrast to this black groundwork the cabinet pictures gain a peculiar sparkling quality, the dark bronze of the busts (there is nothing white in the room) helping to accentuate the brilliant patches of colour. The room by Hierl-Deronco has a wall-covering of violet purple moiré silk, with a deeper shade on skirting board and floor, a rich gold ceiling, a Greek couch in burnished gold and violet. The result of this daring experiment is that the pictures, with only two exceptions, are rendered muddy. For purposes of splendour of colour the nude has always been the grand objective, so that the large nude Diana is fittingly hung in this pagan blaze of purple and gold.

Here I am prompted to ask why so many artists,

of what is known as the advanced school, are so infatuated by ugliness? This mental warp is on the increase, and has spread to all countries; if it were confined to the German race alone it could be better understood, for in the Teutonic character there is an odd love of the grotesquely ugly. Böcklin amused himself, after any great effort to work out a specially beautiful combination, by modelling the most hideous faces; reproductions of them are used as keystones over doors and windows, and their contortions interest the man in the street in every town in South Germany.

It is the photographic papers now which have got hold of the phrase “Art is Nature seen through a temperament,” but very much work possesses no trace of temperament beyond the elemental and primitive. In any work of really high art, there ought to be a poetic aim, “the capacity to

## The Mannheim Tercentenary Exhibition

arouse noble emotion"; this entails sincerity of purpose. Neither technique alone, nor imitation alone, nor idealistic generalisation alone are sufficient for the achievement of a great work of art, and the supreme benediction of style may be given to a naturalistic painter as to an impressionist. All depends on their sincerity, their intensity of feeling and technical ability to express themselves with ease, subtlety and force. Just now these facts are being lost sight of, it is to be hoped not for long; we are indeed suffering from a plethora of men of genius and need badly a few men of talent.

Of course men of cultivated taste do not value a picture solely for its subject, but it requires something more than technical charm and beauty of craftsmanship to make us pardon the repulsive subject of an old man cutting up geese on a stall, much being made of a dirty basin of blood in the foreground. Nor is the elaborate and costly decoration in purple and gold of one of the rooms justified either by subject or by technical accomplishment in the small still-life which is the key note, and the *raison d'être* of the room decoration.

The subject is a coarsely and superficially painted pair of woman's corsets on a chair—nothing more, but enough perhaps!

Coming now to the rooms, the first to call for notice is Room 27 by Otto Rieth. This is arranged as a picture gallery in a private house, a modern room with *baroque* suggestions in the woodwork. The wood is maple, stained blue-grey, inlaid with rosewood and mother-of-pearl, the stained surface shimmering like silk. The wall covering, as well as the couches and chairs, are in deeper tones of blue-grey. A rich deep-toned landscape by De Bock and important canvases by Lavery, Brangwyn, Schönleber, Cairati, and others give an international stamp to the room.

There is an air of distinction about the room by Bermann, with its architectural diversity of projections, niches and alcoves; the room is full of sculpture so arranged as to take advantage of the source of light, a large side window; the pedestals are malachite, and the beauty of marble and bronze is enhanced by the walls which with their silvery patina form a softly shimmering background.

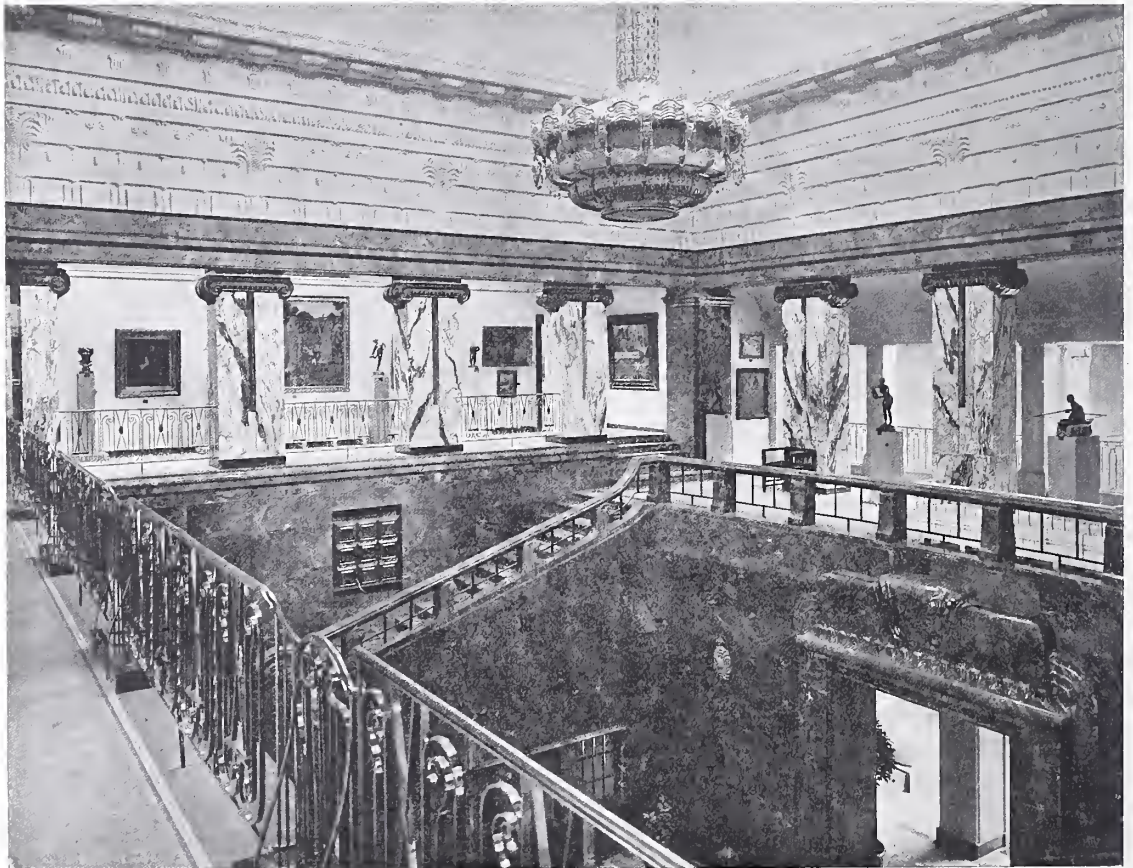

VESTIBULE, MANNHEIM EXHIBITION

DESIGNED BY PROF. H. BILLING



## The Mannheim Tercentenary Exhibition

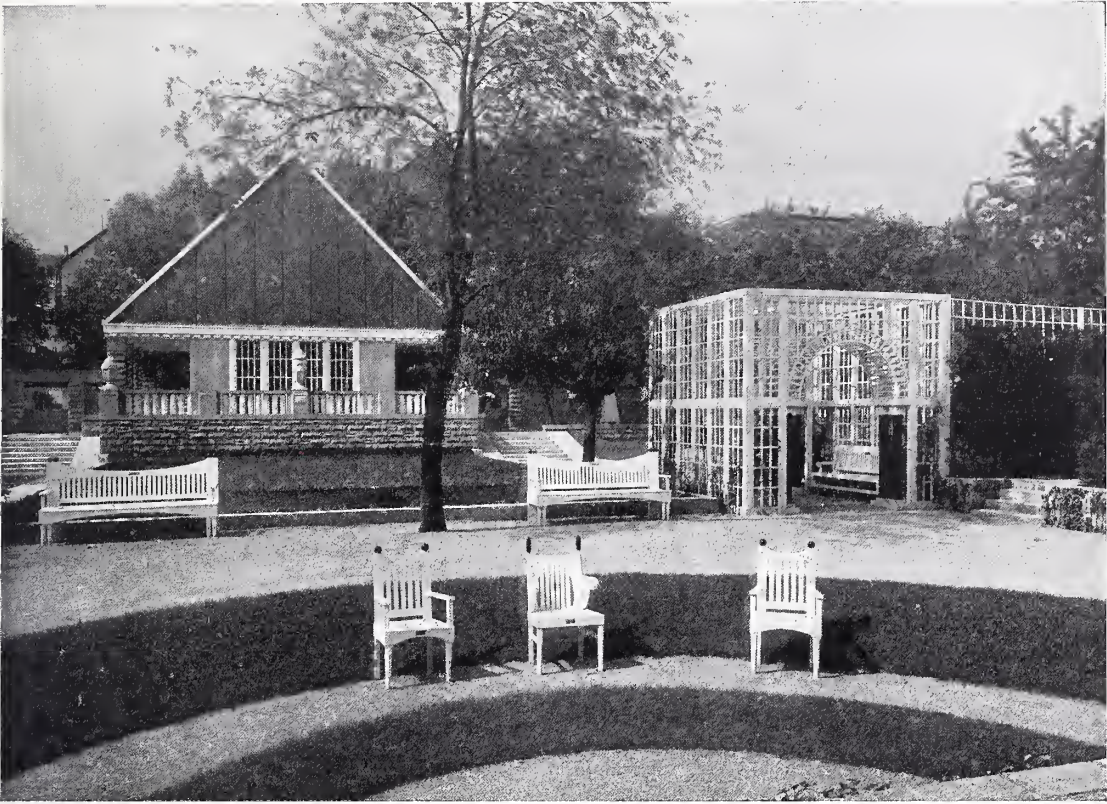

GARDEN WITH OPEN-AIR THEATRE, MANNHEIM EXHIBITION

DESIGNED BY PROF. PETER BEHRENS

The room by Josef Hofmann, of Vienna, strikes one at once by its originality. The floor is tiled with narrow strips of black and white, the walls being also black and white, with discreet use of gold to soften and unite. Professors Hofmann and Kolo Moser have endeavoured to bring together the products of the strongest individualities in Vienna. The result is deeply interesting, but one feels that too much is sacrificed for the sake of novelty.

Room 9 is devoted to Japanese art, and Prutscher has been entirely successful in designing a room in the restrained colour-schemes and wonderful harmonies of the Japanese.

Plastic art has here a numerical importance that is not usual in exhibitions, and whilst there is little of international interest, there is a high standard of merit, though perhaps too much of the pseudo-primitive; but such marvellously modelled works as the *Marble Head*, by Oppler, or the *Mother and Child*, in bronze, by Lagae, are inspired by that realistic idealism which we call classical.

To go back to the pictures, not only is the British Section very strongly represented, but they have found material appreciation, and much of the

work will remain in Mannheim. Cottet has a special room, and Khnopff is also honoured in the same way. His silver-grey drawings, with faint suggestions of colour, are very restful and aristocratic. Dill has six characteristic tempera pictures which do not sit quite happily against their restless background. Hellwag makes a happy departure in technique in his *White Sail*, though a little dry in quality. Frieseke, a young American, has a well modelled nude, and it is evident that he has learnt much from Whistler. Kallmorgen in his sound and vigorous work has shaken off the influence of a school for which he was temperamentally too robust; nevertheless, the experience may have benefited him. Schönleber's beautiful colour schemes and consummate brush-work make him *bien-venu* anywhere; he combines the extreme schools most felicitously.

There are three paintings by Victor Mueller, who died in 1871; his *Head of a Man* is a masterpiece of the first rank, and his *Schneewittchen* is almost as good. How is it possible for a painter of his quality to be so completely forgotten in so short a time? Bantzer's *Hessian Peasants* is a powerful character study; the surface textures

## The Mannheim Tercentenary Exhibition

being realised in a very uncommon way, an important matter which too many of the younger men ignore. Cairati shows that the technique of a *virtuoso* alone can make a picture, though the subject be merely a few earthen vases. A wall is covered by Whistler's etchings, lent by the Victoria and Albert Museum, and with them hangs a superb *Portrait of a Girl* in white, painted in his most fluent manner.

The general idea for garden architecture is due to Professor Luger, who has also a special garden, with a long pavilion designed for a bath-house, and an open pool in front. Many of the gardens are designed by well-known architects and artists; some in a severe and formal style, others more freely decorated landscape gardening, depending for their effect more on colour and arrangement of flower-beds than on masonry.

The old-fashioned formal garden is generally pleasing, not only from its old-world flavour, but from the fact that its cypress, yew or box hedges were cut and trimmed to give an architectural

character, acting as a transition between house and flower garden, which they connected and harmonised. They blended and united in full aesthetic continuity, for the garden walls were living things themselves. They also extended the geometrical plan of the house, and made the garden part of it, and not a separate entity. A house does directly affect the garden; its openings—especially of course its doors—directly come into connection with it, and this demands the garden being kept in the style of the dwelling; here, in Germany, it is the garden architect who is responsible for the result, the dethroned gardener merely carrying out his ideas. The garden serves for entry to the house, as a strolling place, and as an open-air lounge; it is indeed now looked upon, in a sense, as an outside room. The fact that a yew hedge of reasonable height takes half a century to train, made it necessary to replace it by actual masonry. Many garden architects use large unbroken plane surfaces quite free of ornament, simple forms, and straight lines. Monotony can be avoided by variety of surface

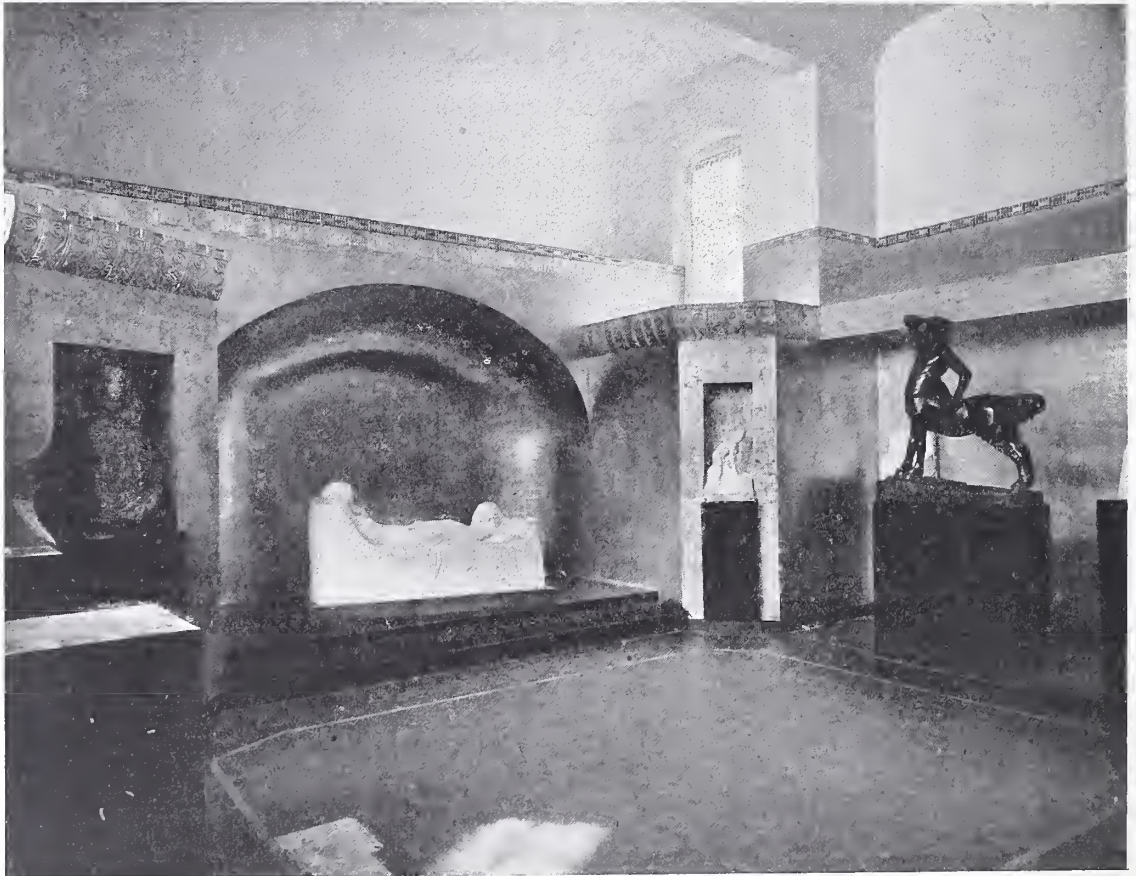

ROOM IN SILVER, MANNHEIM EXHIBITION

DESIGNED BY C. A. BERMANN  
SCULPTURE BY THE SAME

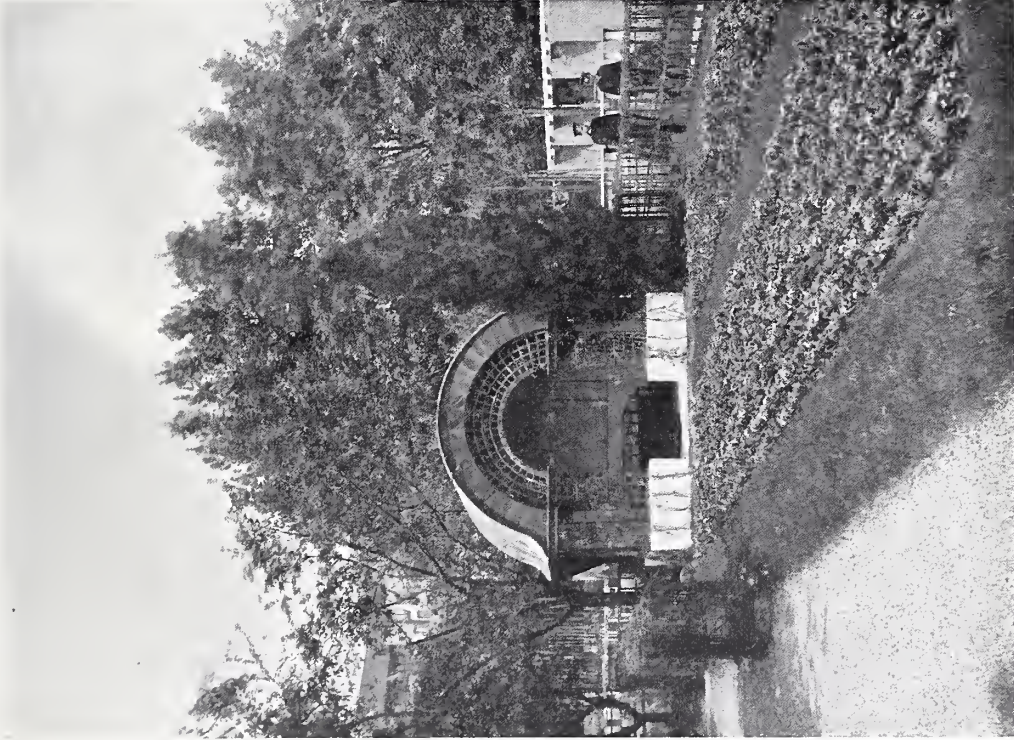
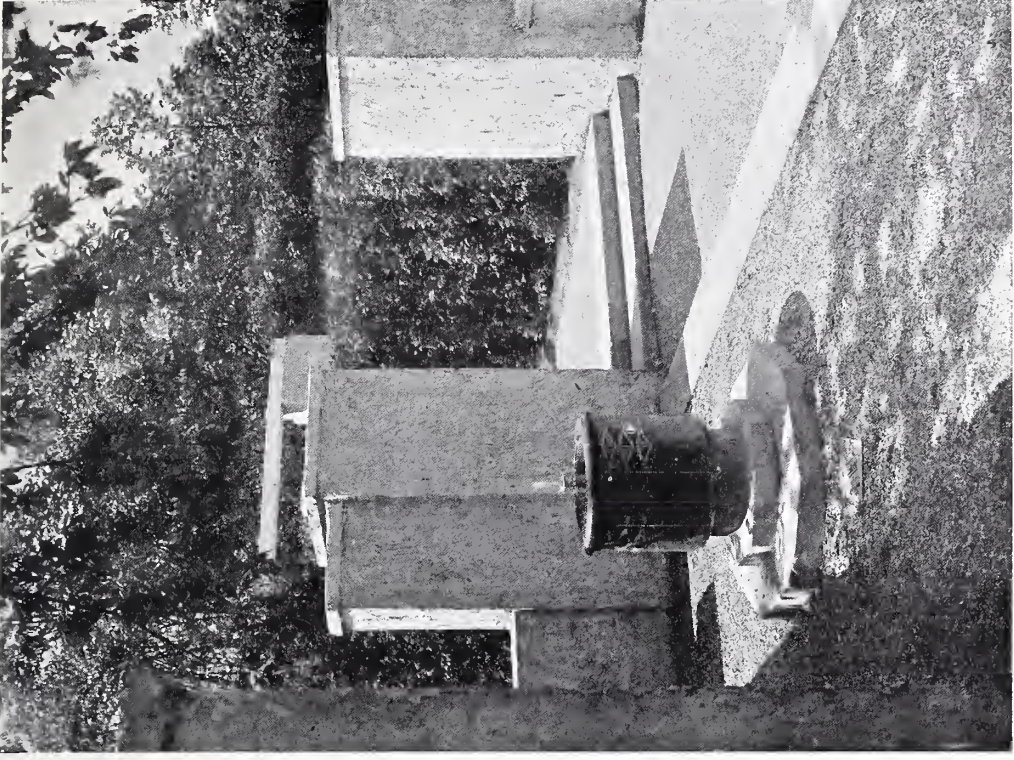

GARDENS AT MANNHEIM EXHIBITION  
DESIGNED BY PROF. MAX LÄUGER

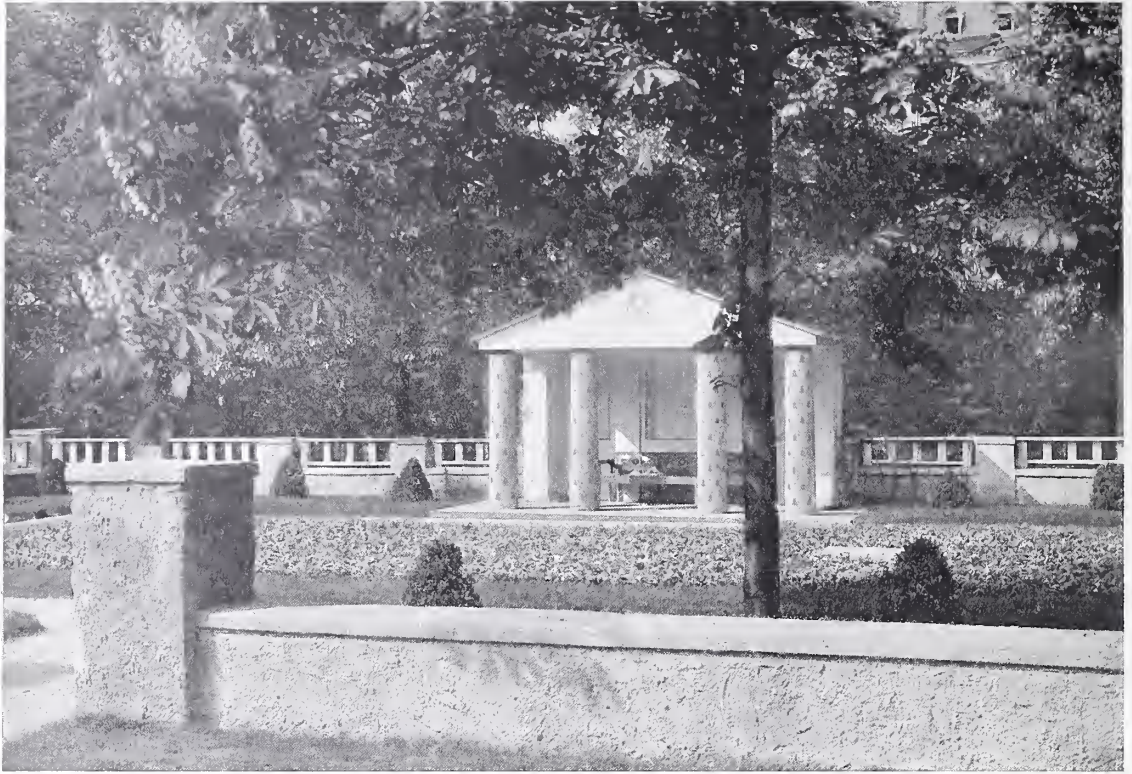

GARDENS AT MANNHEIM EXHIBITION  
DESIGNED BY PROF. MAX LÄUGER

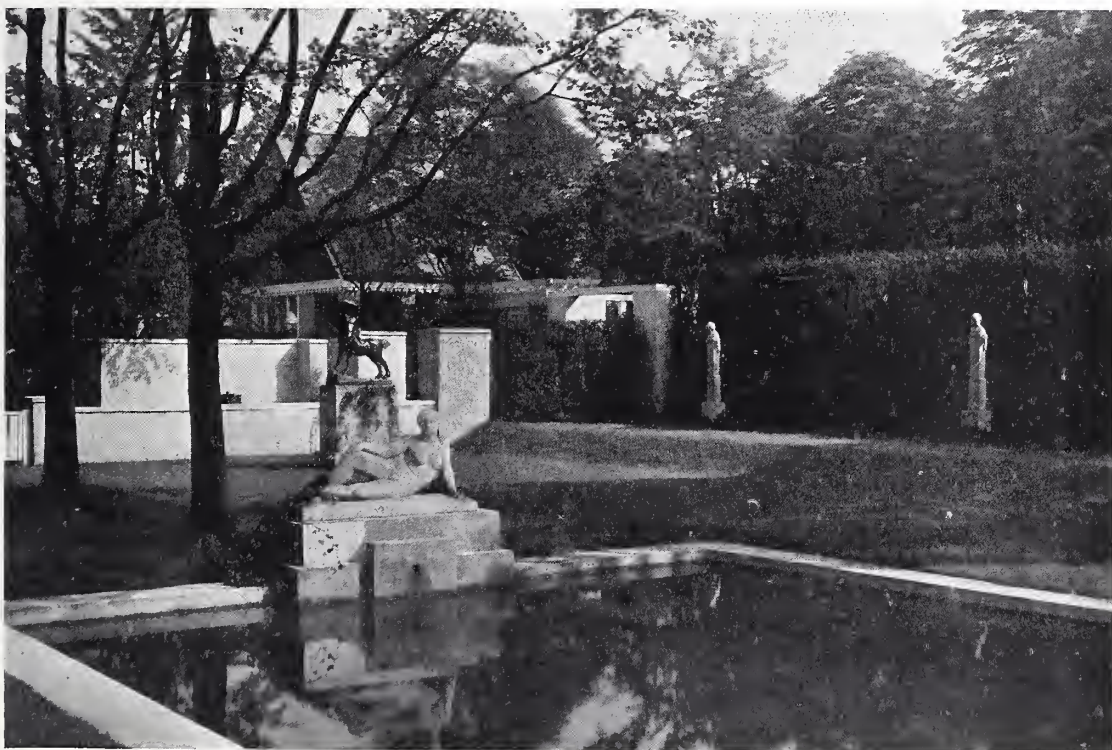

GARDENS AT MANNHEIM EXHIBITION  
DESIGNED BY PROF. MAX LÄUGER

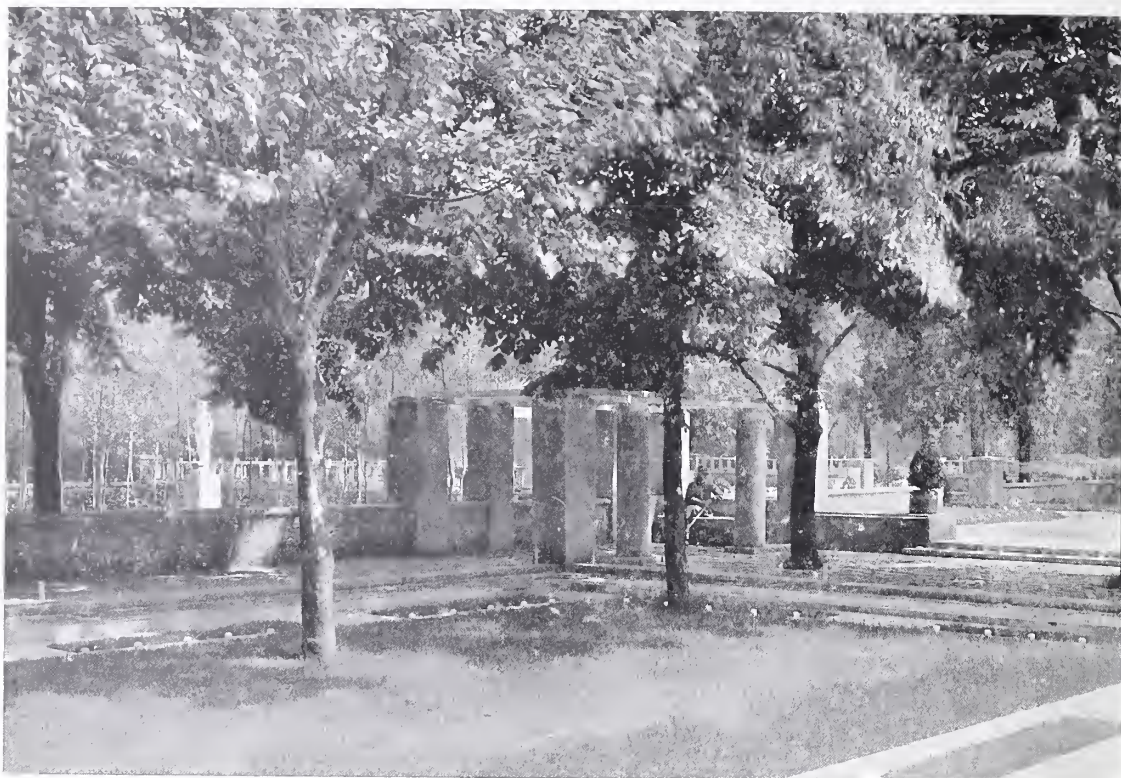

GARDEN AT MANNHEIM EXHIBITION

DESIGNED BY PROF. MAX LAUGER



GARDEN AT MANNHEIM EXHIBITION

DESIGNED BY FR. BRAHE, GARDEN ARCHITECT

## The Photo-Secession in America

and material, and by the use of pergolas or lattice-work, as well as by the judicious use of dark, formal masses of deep-green shrubs, which frame tender greens and give the flowers a jewel-like quality.

Professor Billing's garden consists of circular flower beds rising in terraces, which are crowned with palms and other high-growing plants. He places his flowers in masses of single colours (pale yellow next to dark purple tulips when I saw them), all arranged to bring out effective contrasts. The garden by Roethe Brothers and Jacob Krug is more luxurious—a marble tea-house, between shady pergolas, covered with pendant clusters of wisteria, fountains of bronze and marble, statuary and terraces producing an effect of great elegance. Architect Brahe's design is characteristic of a garden in the period of Rome's greatest splendour. Schulze-Naumburg has a simple suburban garden enclosed by high walls and espalier fruit trees, the centre space being a simple lawn; and Henken has imitated a Japanese garden with great skill and taste.

F. BENTZ.

was shown the first of three notable annual salons. Finally, with a desire to put forward all that was best in photographic possibilities, the Photo-Secession was inaugurated on February 17, 1902, the real movement toward the organisation having developed in consequence of the three salons already mentioned.

The decisive note, however, was sounded in 1901, when Mr. Stieglitz, who had been keeping together the ends that reached from the various centres of interest, and whose influence both at home and abroad was more extensive than that of anyone else, was requested to give an exhibition of his own work at the Arts Club. Instead of making a "one-man-show" of the affair, Mr. Stieglitz, keenly appreciating the welfare of the movement as a whole, very generously proposed to hold a comprehensive exhibit of American works. The idea was to present the varied character in manner of expression of such individual photographers as ranked high in their art. It was to show that a vitality, which was his own, stamped the work of each, so that it would lead to the recognition of its

### THE PHOTO-SECESSION IN AMERICA. BY MAUDE I. G. OLIVER.

It is now over nineteen years since the initial step was taken toward the uplifting of simple photography in America to the dignity of photographic art, the year 1886 having marked an epoch in the history of the movement. Then it was that the first exhibit aspiring to anything like international importance was held; and, at its close, what became known as the "New York, Philadelphia and Boston Joint Exhibition Series" was established. The institution, which provided for annual displays to be presented successively in each of the three centres, continued with increasingly satisfactory results until the spring of 1894, when, from the artistic standpoint, a most encouraging collection was shown in New York. It was one which had been able to demonstrate conclusively the existence of talent sufficient to withstand the sharp test of a rigorous jury. For the ensuing four years no outward sign of activity was evidenced, although the true life of the work was gaining in force and, in 1898, culled from the most rigid system of selection,



CHILD STUDY

BY EMMA SPENCER

## *The Photo-Secession in America*

author unaided by catalogue or signature. Not that the works themselves are necessarily distinguished by reason of the impress of those who bring them forth, yet, through the study of works of this order it is that the individualities of their creators are perceived.

Such an exhibition was held, and, in referring to it as "An Exhibition by the Photo-Secession," Mr. Stieglitz unconsciously offered the most fitting name for the organisation that was destined to spring from that initial movement. There was no jury, the work simply having been presented in response to the invitation by Mr. Stieglitz. Later, when the proper conditions arose, the "Photo-Secession" was regularly organised.

The members now composing its fellows are: John G. Bullock, Wm. B. Dyer, Frank K. Eugene, Dallet Fuguet, Gertrude Käsebier, John T. Keiley, Robt. S. Redfield, Eva Watson-Schütze, Eduard J. Steichen, John Francis Strauss, Clarence H. White, Alvin Langdon Coburn, Mary Devens, W. F. James, Wm. B. Post, Sarah C. Sears, and S. L. Willard. Of these, the first twelve represent the founders of the "Photo-Secession," who serve as the council for the first three years. Besides this group, there is a list of over fifty names now composing the associates.

As stated officially, "the aim of the Photo-Secession is loosely to hold together those Americans devoted to pictorial photography in their endeavour to compel its recognition, not as a handmaiden of art, but as a distinctive medium of individual expression." That this creed has proved its claim for respectful recognition has already been demonstrated in consequence of numerous successful exhibitions held both in Europe and America. It is one of the policies of the society that its members never exhibit under its name, except through invitation and as a unit, although, of course, individual members are free to exhibit independently if they choose, in which case, however, their works would not appear with those of the selected group. And the gospel

of progress, as an innate conviction with the fraternity, is evidenced in the widening interest that these collections attract among the æsthetic circles of true art lovers. Exhibiting thus in a concerted body, the separate works of a collection escape contact with a jury. Indeed, standing for principle as they do, those in authority strive for the reputation of never allowing work that is unworthy to pass their hands, and, from the nature of their peculiar training, the accredited representatives of pictorial photographic art feel that they are able not only to judge more accurately than the painter (unless he is also a photographer and understands photographic quality as a vital character of the print) concerning examples in their own field, but that they are equally competent in criticising certain elements in the painter's own work.

The important principle appears to be that a



PORTRAIT OF ALFRED JUERGENS

BY W. F. JAMES





GIRL'S HEAD. FROM THE PHOTOGRAPH BY EVA WATSON-SCHÜTZE.



## The Photo-Secession in America

photograph never should partake of the nature of the conventional media, but that effects produced by the latter may be consistently expressed in terms of photography. The law seems to obtain that, just as when one is bereft of certain faculties those remaining become more acute, so refinement and directness of execution, when limited in range of media, become more subtle, more beautiful. And since the best operator in any craft is acknowledged to be the best judge of excellence in the productions of that craft; similarly, the most artistic operator in the photographic craft should be recognised as the most efficient judge of his own specialities in any picture.

Again, the rarity of a good print elevates its production from the realm of a commercial mediocrity to the realm of conscious, living art. And, just as truly is it in the mind of the inspirational photographer one day to produce that elusive something of his fairest dreams, which to him stands for his masterpiece, as ever it was in the mind of a Da Vinci or an Angelo. The dust heaps of the centuries are filled with the abortive efforts of those who have failed in expressing the universal ideal. And the final estimate of any significant period in the world's progress, whether in the field intellectual or æsthetic, the real evidence of lasting good, will be embodied in such works as have stood the test of time. Yet this idea of the important feature being the thought reproduced in the work is plainly to be observed in the attainments of the Photo-Secession, although still in its infancy.

In analysing examples of the society in general, one is forced to recognise the reflections of the personalities who conceived them. The work of Alfred Stieglitz, for example, indicates in no small measure the organising, persevering and determined spirit of

the man. Mr. Stieglitz, who, besides being an artistic photographer, is also the editor of "Camera Work," evinces in his photo essays that fine, analytical consideration of a subject which would naturally characterise one who was capable not only of producing a picture, but who could criticise with equal ability. Since he identified himself with art photography when it was quite in its inception, his work in this field has been practically contemporaneous with the movement. Pre-eminently a technician, this artist displays a refinement and seriousness of intention that indicate a poetic temperament. Mr. Stieglitz's well-known subject, *The Hand of Man*, reproduced in the Special Summer Number of THE STUDIO, 1905 ("Art in Photography"), strikingly illustrates this earnestness of purpose being carried out to such perfection of finish as to give the sheet, while still holding to the



"LADY IN WHITE"

BY EVA WATSON-SCHÜTZE



"MRS. LUCY WYETH"  
BY CLARENCE H. WHITE



“MISS CRAWLEY.” BY  
WILLIAM B. DYER

## The Photo-Secession in America

profound message of the story, the softness of a mystic atmosphere.

Joseph T. Keiley, a co-worker in many valuable experiments with Mr. Stieglitz, and, with Messrs. Strauss and Fuguet, associate editor on the staff of "Camera Work," is an artist with a temperament inclined towards mysticism. He is one who works under the spell of inspiration, rarely producing more than one finished print from the same negative, and, because he is conscientious in niceties of execution, that print naturally is a jewel of its kind. The suppression of detail is one of Mr. Keiley's technical faculties, and this in itself gives largeness and directness of intention to his pictures.

John Francis Strauss, another leader in the New York circle, although of recent years his work has been more closely identified with the literary side of his art, is still a clever craftsman who displays a refreshing sense of always working directly for his results, and, however varied his choice of subjects, he understands perfectly how to enter at once fully into their spirit.

In connection with the New York fellowship mention should be enthusiastic regarding that young *virtuoso* of the printing frame, Mr. Eduard J. Steichen. Being a painter of merit, Mr. Steichen is able to present a remarkably suave manner of brushwork, a technique that is fluid and luminous, and which at the same time contains depths of velvety richness as well as lights of gem-like lustre. Equally fortunate, whether dealing with studies of the human form or landscape, he is perhaps best known as a portraitist. In this class of subjects he is almost startling in his ability to bring not only the bald facts of a likeness, but something of the archetypal man, his aspirations and his life, for whom the likeness stands. This is especially true of his descriptions of the three great men, Lenbach, G. F. Watts and Rodin.

Mr. Edmond Stirling was one of those most stimulated by the salon movement, and his work rapidly developed with rare refine-

ment a sweet quaintness of spirit and an even quality of execution, very low in tone.

Mr. Alvin L. Coburn's work has been reproduced and noticed in *THE STUDIO* on more than one occasion of late, and there is consequently no need to say more about it here. During the past year or two he has made Europe the field of his labours, and the two pictures now given are admirable examples of his recent achievements.

Mr. John J. Bullock of Philadelphia is an artist who shows a refreshing candour in his approach to nature. His reverence for her is of a wholesome, manly sort, unaffected but strong. His taste in arrangement is almost infallible, and, together with a studious consideration of brush development, it produces a result that is serious and refined.

Mr. W. B. Dyer, a Chicago man, likes to con-



"THE STATUETTE"

BY CLARENCE H. WHITE

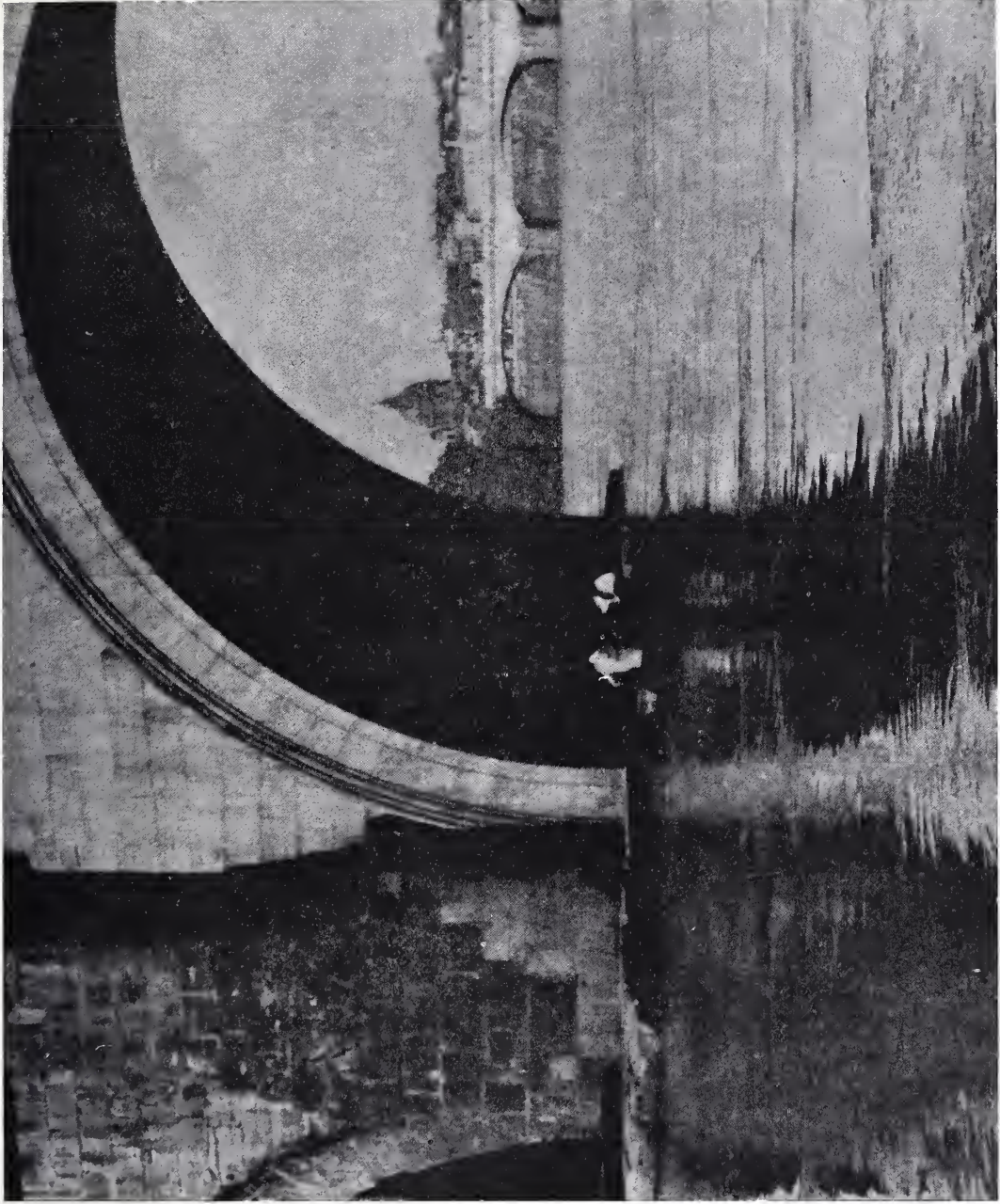

"PONTE S. ANGELO, ROME"  
BY ALVIN L. COBURN

## The Photo-Secession in America

ceive little lyrics, relating to various aspects of human life, which he arranges in logical series. One of his most appealing achievements is that entitled *The Wandering Brush*. This is a gum print which the artist confesses might have been accidental in its results, for, although he worked from the beginning with a positive effect in view, he has never since been able to reproduce the picture. But such works do not need to be reproduced; one is sufficient as a type, and that is enough to teach its message. The treatise in question tells of the growing inspiration of a painter from the time when he first sits down to his canvas with only chaotic ideas of a few fine sweeping lines, until the time when a form of beauty has begun to emerge from the "wandering" strokes of his brush. *Rosa Columbian* (p. 214), a riot of beautiful curves, shows a background, formed chiefly by the melting tones of a portrait on the wall, which combines with the mass produced by a quaint character study in profile. In portraiture, Mr. Dyer is especially strong, as the admirable study of *Miss Crawley* (p. 205) convincingly attests.

S. L. Willard, likewise a Chicagoan, and Frederick K. Lawrence as well, are men whose names are familiarly known in exhibitions on both sides of the Atlantic. Mr. Willard delights us in tender,

imaginative renditions of rural landscape, and in a subtle mystery of tones as applied to his figure interpretations. Of the latter class of work, the decorative panel, called *The Lotus Eater* (p. 211), is a striking example. Among some very attractive landscapes by Mr. Willard, might be mentioned *Spring Song*, *Memory of Glenview* and *Golden October* (p. 212).

Mr. Lawrence appreciates keenly the witchery of rustic nature. What the impressionists have sought to express with their prismatic colours, he feels intuitively through his photographic lens, only he sees the dance of sunbeams wreathing itself into elfin fancies, examples of this mystic touch being exemplified in his performances, *Springtime* (below) and *The Fairy Woods* (p. 213).

William F. James, another name in the Chicago list, is also a very sincere worker, a man who is quite independent even of his brother Secessionists, deriving his greatest pleasure from the opportunity of setting down his impressions in the language of photography. With him, the feeling seems to be no compromise between him and the direct accomplishment of his work, which, naturally is straightforward, devoid of embellishments and essentially truthful. His portrait of *Alfred Juergens*, the painter (p. 200) has been much admired.



"SPRINGTIME"

BY FREDERICK K. LAWRENCE



## The Photo-Secession in America



“THE LOTUS EATER”

BY S. L. WILLARD

Clarence H. White, of Newark, Ohio, is located where he can receive new inspiration constantly from the freedom of the “open.” More than one of Mr. White’s most distinguished accomplishments have been composed entirely with out-door settings. In these, glimpses of quaint, conventional gardens vie with the homely effects of orchard landscapes. With such subjects, Mr. White has been especially successful in the line of illustration. Simple and direct in all his work, Mr. White portrays a peculiar grace in his figure treatments. *The Kiss* for instance, revealing the shadowy forms of two young girls, is almost ethereal in its poetic significance; and a delightfully simple rendition is his narrow panel portrait of *Miss J. D. Reynolds*, reproduced like the last-mentioned print in “Art in Photography.” *The Statuette*, and the portrait of *Miss Lucy Wyeth* (pp. 206 and 204), are also noteworthy prints.

T. M. Edmiston, who is also a Newark man, is an earnest, convincing artist—one to whom sentiment is a reality and to whom poetry is a mission. A good example of his sympathetic rendering is *In the Wood* (p. 214), a fanciful picture of two young women gowned in old-fashioned attire.

Of the women artists in the field, Miss Gertrude Käsebier, who belongs to the New York group, is one of the most accomplished labourers. An item of personal interest in her history is that she enjoys the distinction of having been the first American painter to have entered the ranks of the professional photographers, and while in no way sug-

gesting the sense of imitation, her keen, unerring perception, together with her intelligent treatments, reflect to a large degree in her photographic art her experiences as a painter. In her delineation of women, two examples of which were given in “Art in Photography,” she evinces a charm that is wholly irresistible—it is delicacy and grace personified and united in one.

Mrs. Eva Watson-Schütze has received excellent training in the academic branches, having devoted some six years to the departments of drawing and modelling at the Pennsylvania Academy. Mrs. Watson-Schütze is a Chicago woman, who, while she identifies herself with western ideas, still keeps in touch with the east, her former home; and, above all, remains true to her own convictions. Indeed, no artist of distinction, no period or fad, nor the influence of any medium, aside from photography, has the least hold upon her. Beyond this, she is in love with her work, so that her marked originality is always impressed with a rare tenderness of feeling. As a portrait artist she has met with unusual success, her studies of *Clarence White* and *Wm. B. Yeats* being particularly good examples. Again, in characterisation Mrs. Watson-Schütze is exceedingly apt, as her bewitching creation of *Kundry* in “Art in Photography” and the two subjects here reproduced convincingly show. Wherever is to be found her rather naïve seal, consisting of a conventionalised dragonfly enclosed in a loosely sketched rectangle, one is sure to observe an interpretation of lofty

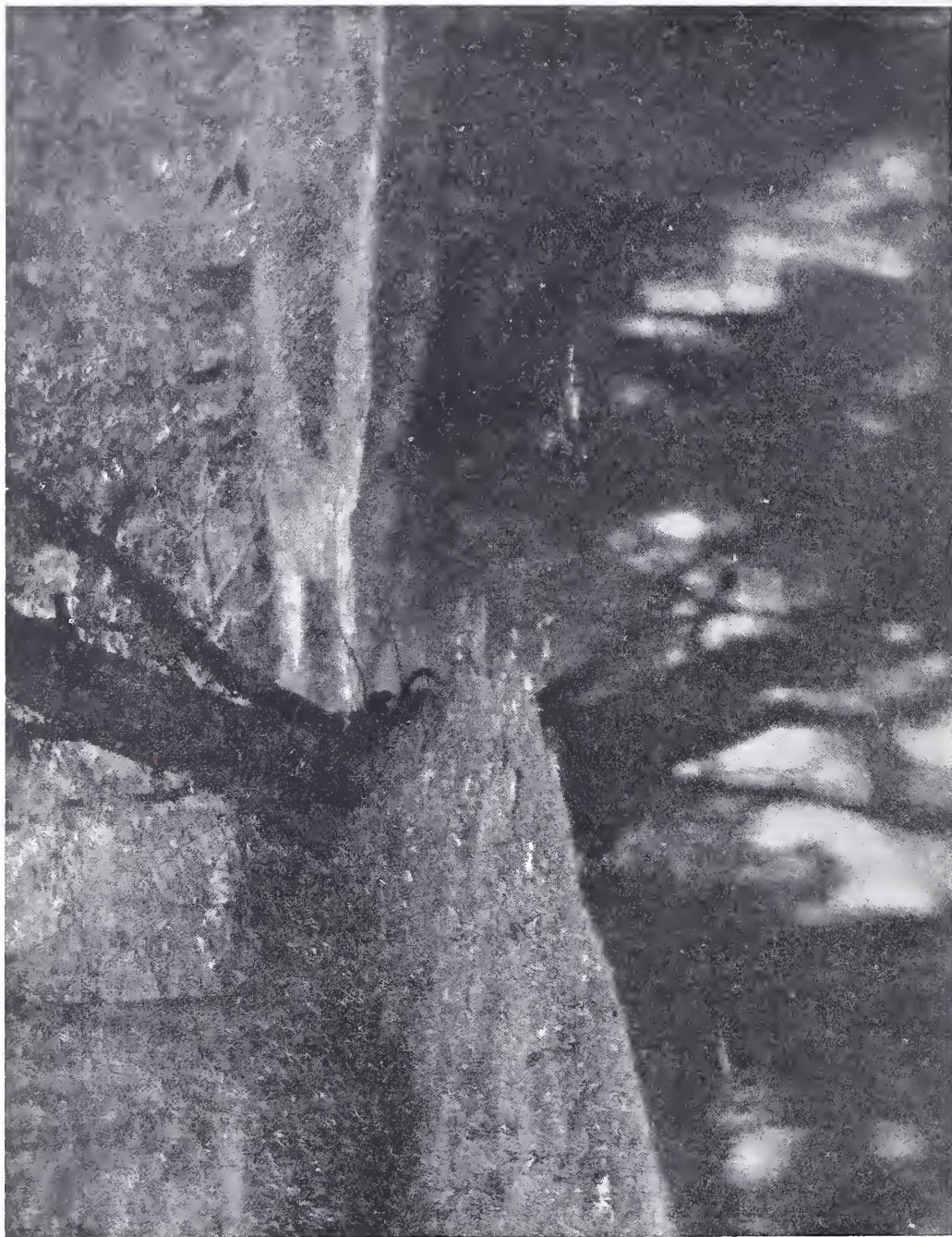

"GOLDEN OCTOBER"  
BY S. L. WILLARD

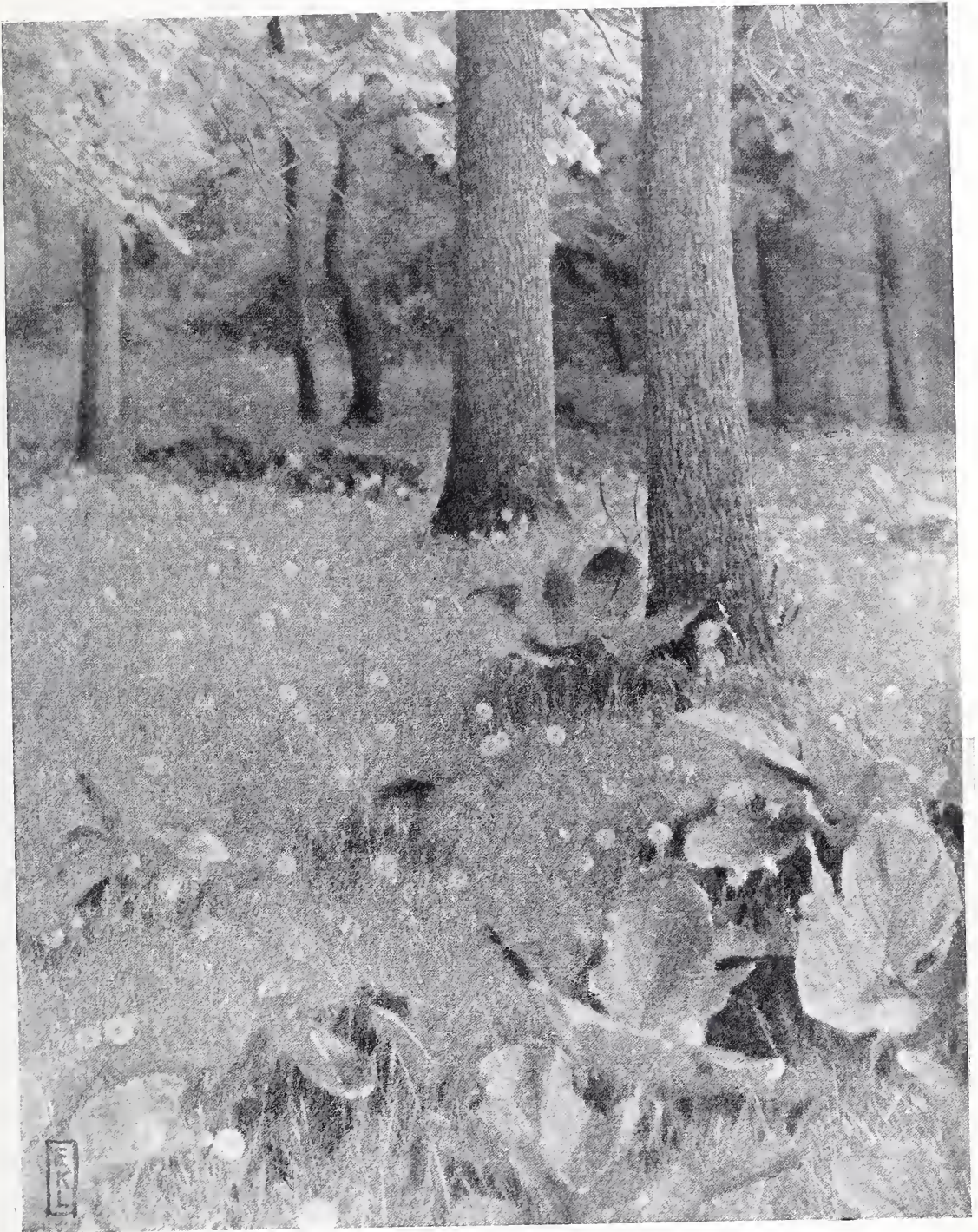

"THE FAIRY WOODS." BY  
FREDERICK K. LAWRENCE



“ROSA COLUMBIER”

BY W. E. DYER



“IN THE WOOD”

BY T. M. EDMISTON

*Recent Designs in Domestic Architecture*



“PRINCESS COTTAGE” (PRINCESSHÄUSCHEN), WOLFSGARTEN  
JOSEF OLBRICH, ARCHITECT

achievements of the brush—the unerring nicety of light itself to the imaginative creations of the poet’s fancy—and the result is a definitive fixing of the spirit of things heretofore unknown. Science has laid at the feet of Art a helpful offering.

M. I. G. O.

**R**ECENT DESIGNS IN  
DOMESTIC ARCHI-  
TECTURE.

IN the series of illustrations given on this and the four following pages, we reproduce examples of the work of Professor Josef Olbrich, for permission to do which we owe thanks to Messrs. A. Wasmuth & Co., of Berlin.

The “Princesshäuschen,” or cottage, was erected in honour of the young Princess Elisabeth of Hesse-Darmstadt, a niece of the Emperor of Russia, but since her lamented death at St. Petersburg it

thought, intellectual without coldness, emotional without unrest.

Miss Emma Spencer of the Newark fraternity, while not at all conservative in her restraint, is so thoroughly unassuming in her methods, that a quiet little message from her printing frame, such as the small person engaged in filling her plates spread out on the floor for the imaginary feast (p. 199), is touchingly appealing.

Although far from complete, these few random sketches, dealing with the attainments of individuals who belong to the new school of photography in America, are at least representative. Standing as the symbol of a scientific age, this wondrous child of the nineteenth century, Photography, is, in the hands of a master, as plastic as clay, as mobile as the brush, and is justly ranked on an equal footing with her sister arts. Add the achievements of the camera to the already known



“PRINCESS COTTAGE” (PRINCESSHÄUSCHEN), WOLFSGARTEN  
JOSEF OLBRICH, ARCHITECT



"THE CORNER-HOUSE," DARMSTADT : DINING AND LIVING-ROOM  
(See also p. 219.) JOSEF OLBRICH, ARCHITECT

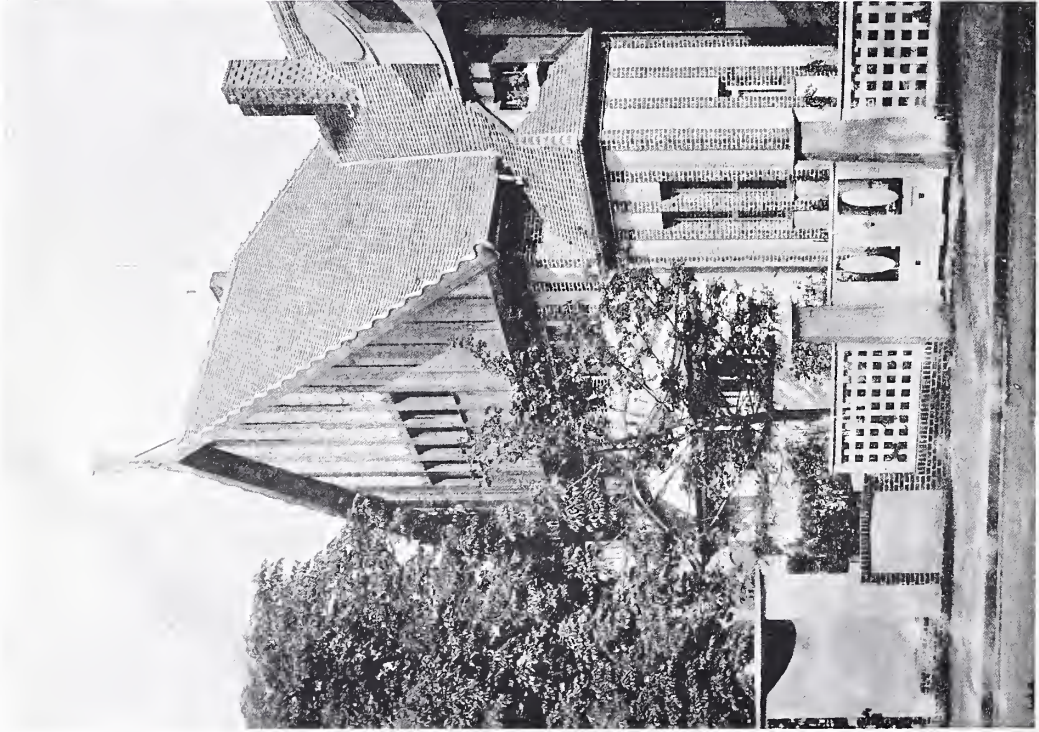

HOUSE WITH WOODEN GABLE (HOLZGIEBELHAUS), DARMSTADT  
JOSEF OLBRICH, ARCHITECT

## Recent Designs in Domestic Architecture

has remained untenanted. The illustrations give a good view of the front and side elevations.

The house with the wooden gable (Holzgiebelhaus) is situated on the Mathildenhöhe, near Darmstadt. The gable is, of course, its most characteristic feature, but the entire building is an interesting example of modern German architectural design.

Of another house at Darmstadt designed by Professor Olbrich—the “Eckhaus,” or Corner House—we give an illustration of the garden gate, the living-room (which, as will be seen, communicates with the dining-room), and of the kitchen, the last being notable for the general simplicity of design throughout.

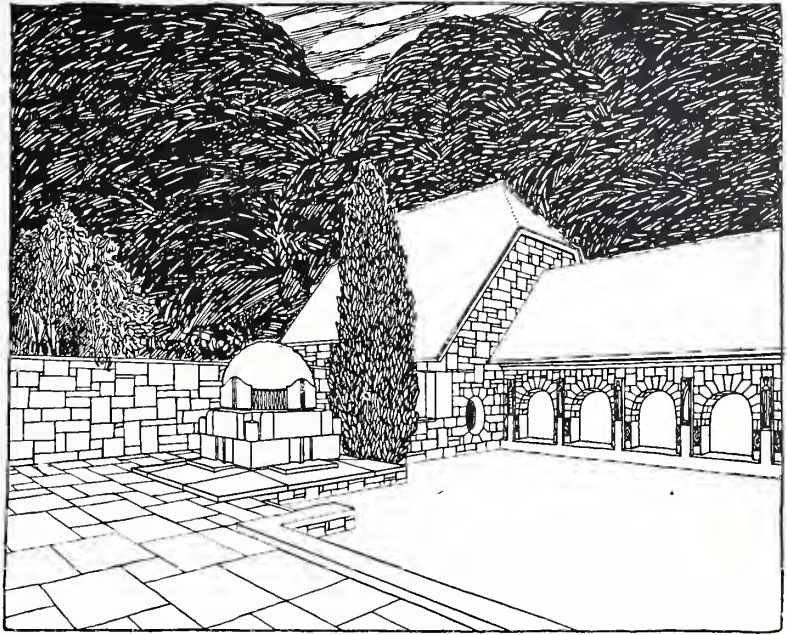

“THE LADIES’ ROSE COURT” (DER FRAUEN ROSENHOF), COLOGNE  
JOSEF OLBRICH, ARCHITECT

The “Ladies’ Rose Court” (Der Frauen Rosenhof), of which we give four illustrations, was

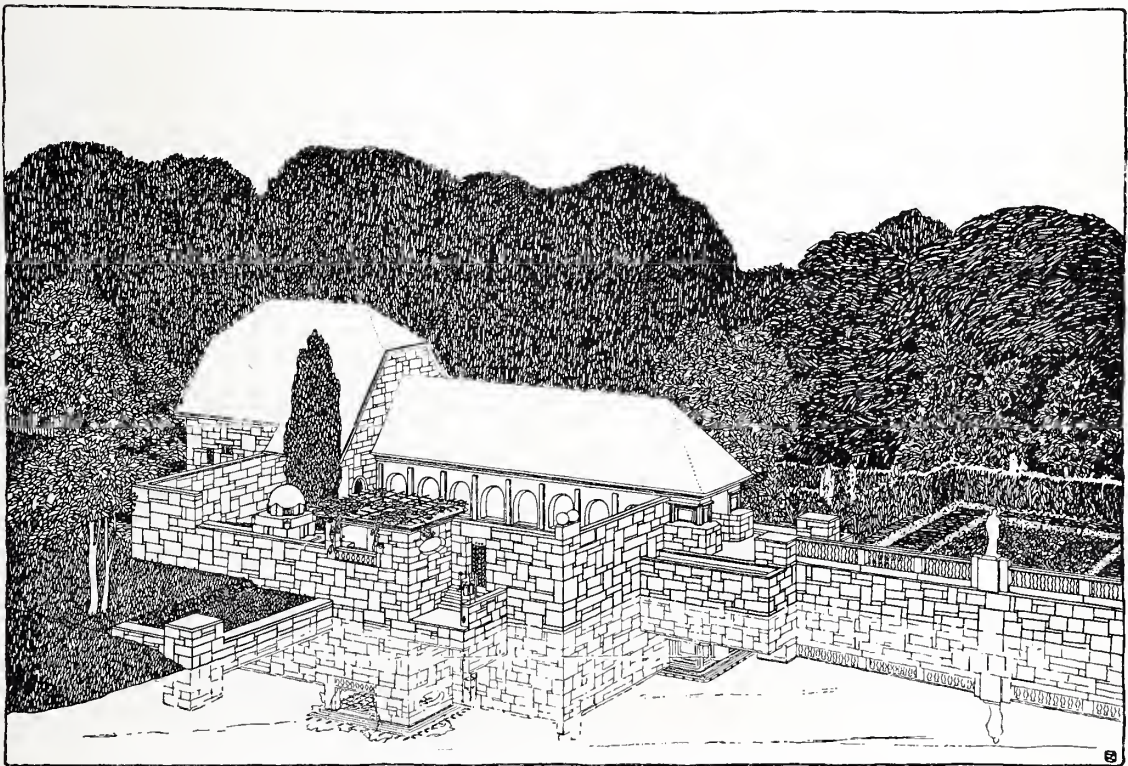

“THE LADIES’ ROSE COURT” (DER FRAUEN ROSENHOF), COLOGNE

JOSEF OLBRICH, ARCHITECT

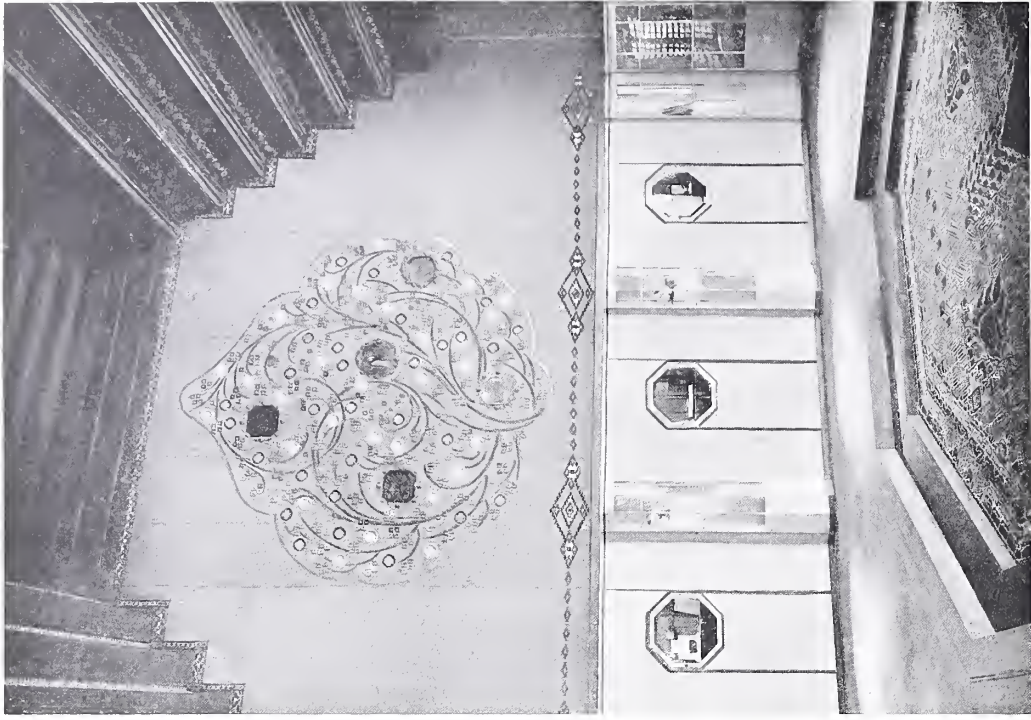

HALL OF "THE LADIES' ROSE COURT"  
COLOGNE. JOSEF OLBRICH, ARCHITECT



## Modern Stage Mounting in Germany

designed by Professor Olbrich for the "Flora" Horticultural Society at Cologne, for erection in their grounds near the banks of the Rhine. The idea of this "Rose Court" is a happy one, and is of especial significance in relation to the revival of the ancient "Cölner Blumenspiele"—the floral festival of days gone by, in which the burgesses and their wives took part. The hall, of which two views are given, is well adapted to the holding of arts and crafts exhibitions, and is, in fact, being used for that purpose this season. W.S.

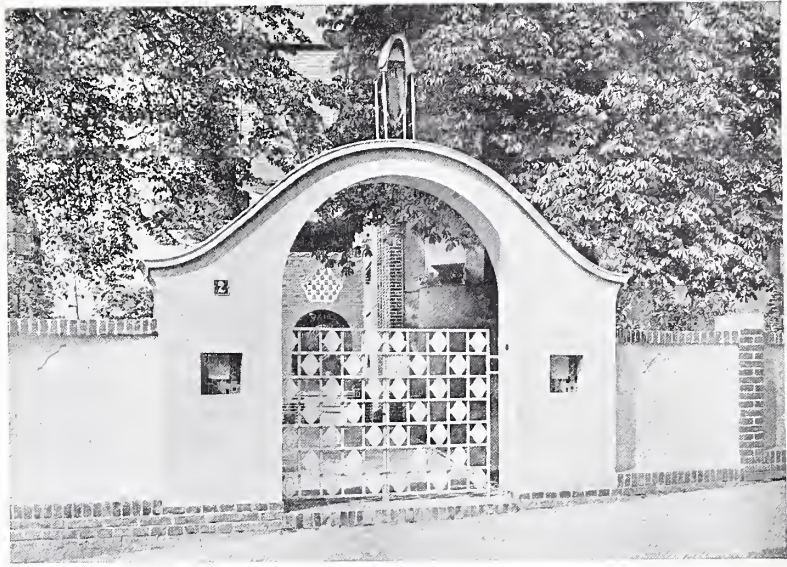

"THE CORNER HOUSE" (DAS ECKHAUS), DARMSTADT: GARDEN GATE  
JOSEF OLBRICH, ARCHITECT

### MODERN STAGE MOUNTING IN GERMANY.—II. ORLIK'S "A WINTER'S TALE," AT BERLIN. BY PROF. HANS W. SINGER.

To bestow a proper amount of care upon the



"THE CORNER HOUSE," DARMSTADT: KITCHEN  
JOSEF OLBRICH, ARCHITECT

mounting of one of the standard plays or operas is still an occurrence of such comparative rarity that whenever it does happen an undue amount of attention is raised thereby. Conservative people have not failed to hunt down this weak point, and have decried the innovators who "bury the poetical values of a drama beneath an opulent display of scenery and costume," as they put it; or, in other words, "who make a mere spectacle out of the best that our great musicians and dramatic authors have given us." Such a reproof would not apply to the manager who brings out "Oberon" in a new garb, for "Oberon" is certainly a popular and good but not one of our best operas. The book is wretched enough, such numbers of the score as have stood the test of time do not suffer in the least by being set off upon a background of beautiful stage mounting.

The reproof would likewise not apply to the manager of the Deutsches Theater at Berlin for having revived "A Winter's Tale." Despite its many individually beautiful passages, "A Winter's Tale" is one among the least harmonious of Shakspeare's plays. From the very first scene the tragic vein strikes so high a pitch that anything like development is out of the question. Leontes' unaccountably fierce jealousy and its dire effects upon

## Modern Stage Mounting in Germany

all his surroundings are painted from the outset in the most sombre colours, totally unrelieved by any natural touches. The lighter vein of the piece scarcely acts as a foil to the tragic scenes, as it would do if it were limited to the loves of Florizel and Perdita, but distracts us by the farcicalness of Autolycus, the old shepherd, and the clown. Scarcely have we adjusted our mood to sympathise with the sufferings of Hermione, when we are jolted by the buffoonery of the rustics. The contrast naturally disturbs us more when we see the play than when we read it. Any new issue, such as a special feature of *mise-en-scène*, is consequently welcome enough, for it relieves us by adding a new source of interest, and thus diverting us from the disturbing anomalies of the text.

Prof. Orlik has had the entire mounting of the play, costumes and scenery entrusted to his care, and thus has been placed in a more enviable position than Fanto. The text of the original has been somewhat simplified, of course, in order to avoid much shifting of scenery, and the scenery itself pursues the same plan, so that there are only four settings in all.

When the curtain rises for the first time we see what may be characterised as *the* room rather than *a* room. The wings on the right and left consist of masses of pillars of a neutral colour. There is no attempt at realism: there are no doors. The actors make their entries and exits between the wings without passing through any such. The further half of the stage is raised, and half a dozen steps lead up to it right across from wing to wing. Instead of a drop, a pair of large curtains cut off the view with a simple linear ornament—light upon a dull, dark ground. Where the curtains meet at the centre they are occasionally drawn back a bit by invisible hands, and the opening serves as one of the principal entries for the actors. No actual architectural structure is presented to our view; the main principles of architecture rather are suggested to our imagination.

This set is made to serve for all scenes, which

take place in a room, throughout the whole play. There is only one variation, when the stage is reduced to half-length by a "traverse" consisting of another pair of curtains of the same pattern, but this time with the linear design dark upon a light ground. The wings remain unchanged; but in consequence of being lighted differently, they apparently have altered their hue, and the smaller room seems altogether less sombre. It is used, of course, for the slightly less serious scenes of the play.

The wings, moreover, remain unchanged also for the great trial scene, in which the curtains (which act as a drop) are quite withdrawn. Here we find the populace filling the background and hedged in by a rampart, which stands out dark against a light sky. In spite of the extraordinary simplicity of the means employed, this scene is very effective, depending principally upon the powerful contrast between the darkness on the stage, in which the actors appearing during this tragic scene make the impression of silhouettes against a sky seemingly glaring with the rays of the sun already set.

It is difficult to say how far we may be justified in generalising from a single instance. For this one play, however, the Orlik *mise-en-scène* has proved indubitably that an unrealistic mounting like this can do far more towards emphasising the main vein of the author and towards putting us into the proper mood for appreciating the drift of his fancy than any carefully realistic setting could



"A WINTER'S TALE": AUTOLYCUS, THE CLOWN, AND THE OLD SHEPHERD  
BY EMIL ORLIK

## Modern Stage Mounting in Germany



"A WINTER'S TALE": AUTOLYCUS SELLING BALLADS

BY EMIL ORLIK

accomplish. It is to the acting of the principal characters what the sounding-board is to the string.

The costuming of these scenes was, of course, equally unrealistic. Orlik, who generally likes to put in a telling touch of gay colour here and there to enliven an indifferent surrounding, exercised great reserve in this case. All of the costumes were sober and subdued in tone; they even reflected the serious mood of the play, so to speak. Leontes' black and gold robe was distinctly reminiscent of Japanese tone values, though not of Japanese drawing. Beyond that there were scarcely any subtly tasteful combinations in evidence.

Quite in accordance with the character of the play the mounting of the comic parts was altogether different, and joyously realistic. Heretofore these scenes have always been located in Arcadia—by German stage managers at least. They used to be represented as happening in a wood, which might belong to any country, by swains that were of no nationality whatever. Orlik, himself born in Bohemia, takes his cue from Skakspere's stage direction, which speaks of this country, and offers us a most lively picture of Bohemian peasant life.

When the curtain rises we see the common of a Bohemian village, a small hollow of green sward, with a few farmhouses beyond, and only a tree or two in full blossom in the foreground. The birds are singing in the trees (Sada Yacco had this in one of her Japanese plays!), and a number of flags on

poles in the background presage the festive day, witnesses whereof we are soon to become.

We get all the realism of a May-day, cast in a Bohemian garb. The swains and shepherdesses come in laughing and frolicking, romp on the common, start up a country dance and a song, and generally behave as we may expect to see them any day, if we take a trip to their country. For, of course, Orlik could choose his models from the life, since the national costume of the country folk has not changed essentially for centuries.

The vividness of the scene is little less than

overwhelming, and presented after this fashion Shakespeare will no longer appear anything like a "past issue," even to the most untutored, who are ordinarily bored by every play not full of actuality and not thoroughly modern. The great feat was to have dismissed Arcadia, and to have supplanted it by something that appeals direct to the actual experience of the lookers-on. Even then the realism was not of a spiritless kind; with the eye of a fairy-tale illustrator, Orlik had overlooked what is inessential and unprepossessing in nature, depicting her only at her brightest and jolliest.

The first scene of the fourth act was acted in an open arcade, from which a view of the shepherds' common was to be seen. For the introduction to Act IV., Time, as chorus, came in before a drop-scene on which the firmament was painted. This was perhaps less successful than the rest of the mounting. The firmament was painted with planets and other stars in an arbitrary fashion, neither satisfying us as an illusion nor as an allegorical setting for Time's soliloquy.

But the two remaining stage decorations, the prison scene and the one before the palace (Act V., Scene III.) were excellent and worthy of being noted. The stage in each case was a very short one, and each architectural detail was reproduced in its actual dimensions. Perspective drawing is, of course, what has rendered an ordinary scene-painting so absurd. We see a street scene, which

## Modern Stage Mounting in Germany

looks well enough as a picture, and seems all right as long as the actors remain just in front of the footlights, but which gives them no chance to move about. As soon as they do that, such things happen as a moderate-sized man knocking with his helmet up against the keystone of a great cathedral portal in the background. The old scene-painting school, starting from the basis that actual illusion was not the office of the theatre, simply have accepted the function of the stage directions. For the coronation scene in Schiller's "Maid of Orleans" they paint the whole of the Cathedral of Rheims in the background, without the least regard of true perspective, so that the audience may know, without having to consult the book, where the scene takes place. The new school does not care in the least about mere facts, communicable by means of words. Their sole aim is harmony, with or without the illusion of reality, and they will not place the actors in a setting in which they cannot move about without seeming ridiculously out of proportion. They will paint only part of a cathedral porch, no matter

whether not even a single man or woman in the audience can glean therefrom just where the scene takes place.

That the new school exercises the better judgment of the two is beyond a doubt. For even if you accept the very prepossessing theory that upon the stage actual illusion should not be aimed at, and that an attempt at suggestion should take its place, the means adopted by the older school to this end were altogether ill-chosen. For you cannot *suggest* a thing by placing a complete cut-and-dried image of it before anybody's eyes. This, rather, is describing the thing. And the description is awkwardly misleading, since, for one thing, an impression of size is intended to be communicated by means of a picture which reduces actuality to more or less the scale of a miniature.

The prison and the palace-front of Orlik's were genuine in their actual dimensions, and genuine in their structure—*i.e.*, wherever there were any recesses or projections in the ground plan, these were not only painted, but real. This causes, of course, more trouble to the scene painter and' stage

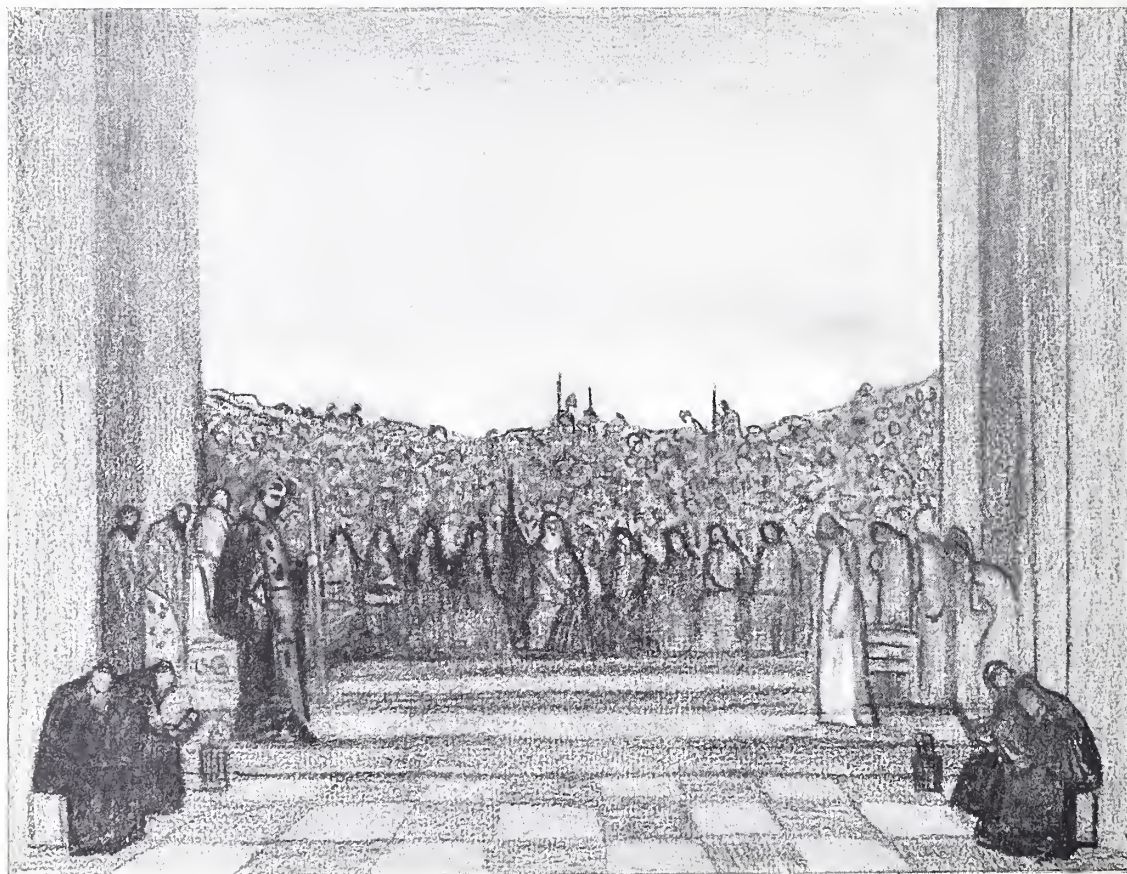

"A WINTER'S TALE": TRIAL SCENE

BY EMIL ORLIK



"A WINTER'S TALE": THE DANCE OF SHEPHERDS BY EMIL ORLIK

carpenter than if a simple drop is let down upon which all these variations from the flat façade are simply painted. But the effect gained is worth the trouble, especially when, as in the present instance, the drop is so close to the footlights that the illusion aimed at by the painting fails in its object.

In many ways Orlik's work differed from Mr. Fanto's. To my mind there was not any such remarkably fine taste for colour-harmonies in evidence, nor so much of the *part-pour-l'art* feeling. But both revolutionise to an equal degree the kind of stage mounting traditional and still generally obtaining with us. Both elevate in various ways the function of appealing to our fancy above that of reporting facts. And Orlik has proved admirably, that this classical drama, which at least to the untutored majority of modern playgoers will seem antiquated, may be invested with all the interest of a modern occurrence partly by bringing the spirit of the comedy down to date, and partly by drawing our attention away from realities that would be perplexing to ideals that stimulate our imagination.

H. W. S.

(Another illustration belonging to this article appears on the next page.)

In the official list of works sold at the International Art Exhibition, Venice, up to 30th June we note that an oil painting by Mr. Grosvenor

Guglielmo, and Emma Ciardi, L. Balestrieri, C. Innocenti, Antonio Ugo (sculptor), G. Grosso, R. Bugatti, A. Milesi, C. Laurenti, A. Fragiaco, A. Mancini, P. Nomellini, L. Selvatico, A. Morbelli, de Maria Bergler, F. Sartorelli, V. Guaccimanni, and G. Beltrami. Other nationalities are represented by Anna Boberg (several of whose paintings were sold, including *Modern Vikings*, which goes to the National Gallery, Rome), Edgar Chahine; V. Scharf, P. Laszlo and R. Quitner (Austria), A. Baertsoen, H. Cassiers, A. Delaunois, V. Rousseau, A. Rassenfossé and F. Khnopff (Belgium), R. Miller and A. Koopman (America), Lerche and Krohg (Norway).

Owing to pressure on our space we have to hold over the further illustrations of Talashkino work announced in our last issue.

## STUDIO-TALK

(From our Own Correspondents)

LONDON.—In connection with the proposed International Memorial to the late James McNeill Whistler, a Drawing-Room Meeting was held last month at the residence, in Chelsea, of Mr. E. J. Horniman, M.P. The chair was taken by Lord Plymouth, the speakers including Mr. Edmund Gosse, Lord Redesdale, and Mr. John Lavery. The memorial is to be placed

in a space allotted by the London County Council on Cheyne Walk, at the west end of the gardens, near Carlyle and near where Whistler lived and worked. "Close to the brown and shining river," which Whistler loved "more intelligently than any man who lived before him," to use the words of Mr. Edmund Gosse, who also reminded his hearers that Whistler gave half his life and half his genius to London. The Memorial will be the work of M. Auguste Rodin, who anticipates its completion towards the end of the year, and its total cost is estimated at £2,000, towards which The International Society of Sculptors, Painters, and Gravers will contribute the sum of £500. The Committee invite subscriptions from the admirers of both artists. Cheques should be made payable to the

Whistler Memorial Fund. The address of the Hon. Sec., Miss Bertha Newcombe, is 1, Cheyne Walk, Chelsea, S.W.

At the Carfax Gallery the exhibition held for Messrs. Charles Ricketts and Charles Shannon afforded an exceptional opportunity for studying their work in the sympathetic environment their works provide for each other. Their paintings always seem the outcome of an imaginative mood rather than the deliberate choice and planning of an imaginative subject—a rhythmical account of beauty felt rather than the beautiful recounting of a legend. In other respects their art is quite dissimilar, Mr. Shannon's being more intimate with beautiful qualities of texture and colour. There is something arid in the atmosphere which Mr. Rickett's art suggests, and by his treatment a vision of Daumier's painting is always called up between us and his picture. Nearly every face is masked with heavy shadows, which serve to define their emaciation, an emaciation, by the way, not compatible with the sometimes rounded and heavy limbs. The insistence upon the one type may be intended figuratively to express contempt of the soul for the body; but its prevalence in every figure would seem to denote a limitation.

There was an old-world flavour about the exhibition held by Mr. Roger Fry and the Hon. Neville Lytton at the Alpine Club. Their water-colours were not dissimilar in style; with a greater decision of touch some of them might pass for works of the earlier schools of English water-colour. There were many water-colour drawings by both artists possessed of rare distinction. For the perfection of his pencil drawing the Hon. Neville Lytton's reputation is established. In his oil paintings he dwarfed his considerable achievements in other canvases by the surpassing success of his portrait of Mrs. MacCarthy.

No one has succeeded better with monotypes than Mr. A. Henry Fullwood in reducing the element of chance in their production to an irreducible minimum. He attempts and succeeds in obtaining quiet passages of colour which we had not thought possible in the monotype. Mr. Fullwood was always the artist, never the mere experimentalist, in the delightful exhibition of his monotypes held at the galleries of Mr. Tinson in Grafton Street. His work proved the possibility of controlling the drawing of small forms, which has so often seemed to limit monotype art.



"A WINTER'S TALE": THE OLD SHEPHERD  
BY EMIL ORLIK

(See article on "Modern Stage Mounting in Germany.")



“CHURCH PARADE IN HYDE PARK” (Exhibited at Messrs. Marchant's Goupil Gallery) BY AUGUSTUS KOOPMAN

Monotypes also found a place in the recent exhibition held by Messrs. Marchant of Mr. Augustus Koopman's work, from which exhibition we have pleasure in here reproducing the oil painting entitled *Church Parade in Hyde Park*, which represents his success in treating figures in sunlight, an achievement to be noted in many subjects varying in character, amongst which *The Milk Girl*, *Old Picardy Courtyard*, was a canvas showing the artist's powers at their best.

At Messrs. Obach & Co.'s Galleries Mr. Frank Mura held last month an exhibition of pictures and charcoal drawings. Mr. Mura successfully imparts the true feeling for English landscape in a style which has benefited much from the study of the Barbizon and Dutch masters. As far back as 1895 his charcoal drawings formed the subject of an article in this magazine; his remarkably skilful drawings in this medium were also in the exhibition, and were supplemented by some very admirable pencil drawings.

The Ryder Gallery Exhibition of water-colour drawings and humorous works dealing with motorists and their cars was particularly interesting. Some admirable portraits by Mr. Percy F. S. Spence of leading motorists, the humorous work of Messrs. Arthur Rackham, John Hassall, Tom Browne, Lawson Wood; drawings by Mr. A. L. Baldry; and the plaster-cast of the Bavarian Club Motor Trophy, lent by Sir H. von Herkomer, R.A., were the more notable features of the exhibition.

At the International Art Gallery, Mr. Tom Mostyn's picture *Christ in the Wilderness* has been on view. It is Mr. Mostyn's gift to delight artists with the handling of his subject, while at the same time making the widest appeal to the public.

The exhibition of paintings recently held by the Earl of Plymouth at Mr. John Baillie's Galleries gave full evidence of Lord Plymouth's very considerable attainments as a painter. The high standard prevailing in his work was supported in other parts of the gallery by the great merit of

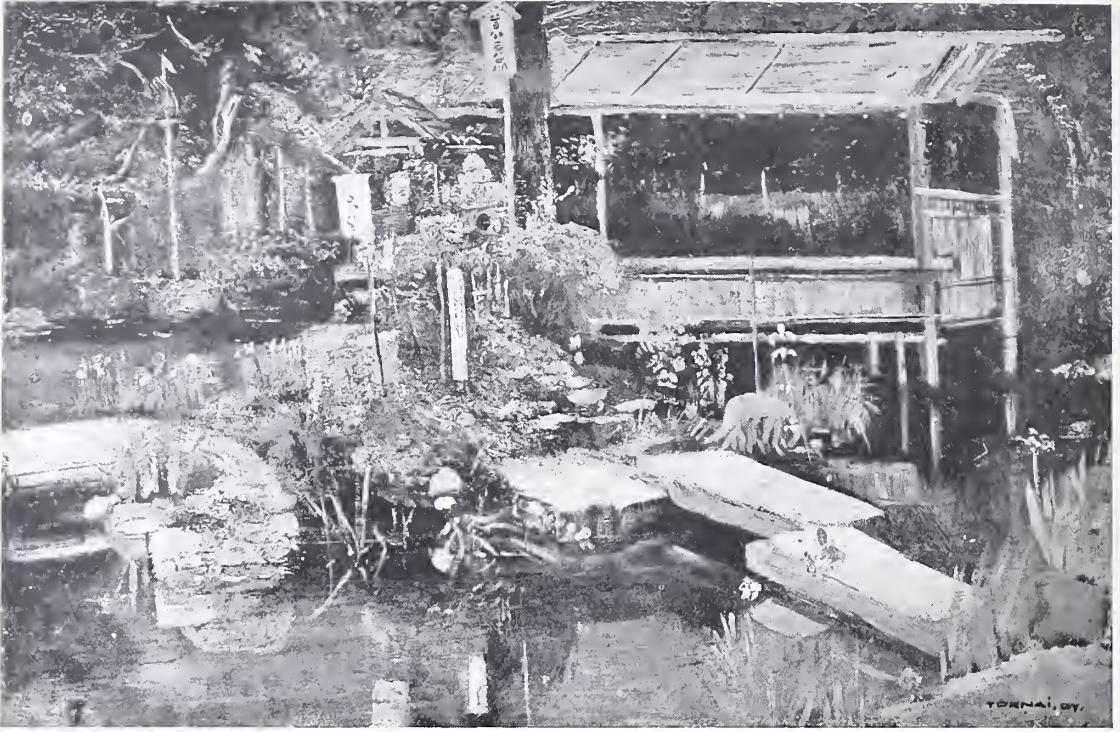

"LITTLE JAPANESE GARDEN"

(Exhibited at Messrs. Marchant's Goupil Gallery)

BY GYULA TORNAI

Miss Sarah Birch's pastels, and the skilful and imaginative panels in relief of Miss E. M. Rope; while some water-colours by Miss March Phillips also formed a part of the attractive exhibition.

he has produced more than one canvas of outstanding achievement. We reproduce one of the pictures.

At the Leicester Galleries, M. Gabriel Nicolet

"Japan and India" was the title of the catalogue of Mr. Gyula Tornai's recent exhibition at Messrs. Marchant and Co.'s Goupil Gallery, and the catalogue was valuably annotated with information as to the subjects of the pictures. A predilection for vivid colour probably took the artist to the East. His enjoyment of it was the feature of the exhibition. We preferred the smaller works for their greater sense of atmosphere; in larger works the artist tended more to be dramatic than artistic, but approaching his subjects with imagination and originality,



PANEL OF ENAMEL BOX, "CUPID AND PSYCHE," IN TRANSLUCENT ENAMEL ON COPPER  
DESIGNED BY LYDIA COOPER



## Studio-Talk

exhibited a series of pencil drawings, entitled *Silhouettes de Femmes*, remarkable for their grace and spontaneity. Mr. Walter Tyndale's Egyptian water-colours at the same gallery showed their perfection in the very accurate but artistic treatment of the subjects chosen.

The little brooch or ornament by Mrs. Geraldine Carr, on this page, claims attention both by its originality of conception and by its delicacy of execution. The enamel is protected by a sort of hinged metal door with a rose design, which is a feature of Mrs. Carr's work. The enamelled design is very delicately cut in *basse-taille*, and its colour scheme is one of tender blues and greens, harmonising with the poetic feeling of the whole.

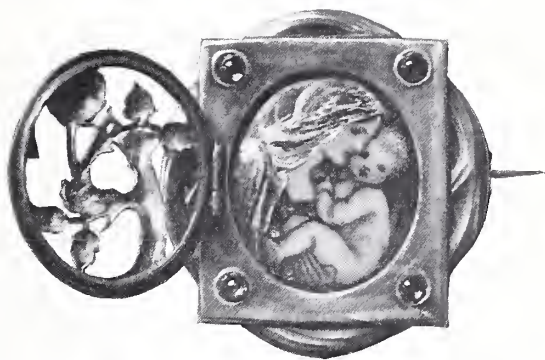

BROOCH IN ENAMEL AND WROUGHT METAL, SET WITH STONES  
BY MRS. GERALDINE CARR

into yellow, and oranges mingling in their hues, with scarcely a trace of blue or green, fitly picture the passion and pain of the story.

The quality most intensely realised as inherent in enamel work by the best artists who practice it is that described by the word "preciousness,"—a word which implies art in its highest sense, delicate discrimination, loving, patient work; all



PANEL OF ENAMEL BOX DESIGNED BY LYDIA COOPER

The Blotting-book Cover by Mrs. Carr, is marked by graceful imagery; executed in translucent and very lustrous enamels on fine silver, its soft green leaves and white flowers in their silver setting make its colour note a skilfully refined one.

The two Casket Panels on copper, by Miss Cooper, show what can be done in employing enamels as a medium of expression. Taking William Morris's rendering of the story of Cupid and Psyche in his "Earthly Paradise," the artist has translated his idea into glowing enamel. Shades of pinks and reds, primrose deepening



BLOTTING-BOOK COVER  
DESIGNED AND EXECUTED BY MRS. G. CARR



ENAMEL PICTURE IN SILVER FRAME WITH DOORS

BY MRS. G. CARR

the things, in fact, that go to make a piece of art-work priceless to those who can appreciate it. The doors before mentioned, as characteristic of Mrs. Carr's enamels, seem to suggest this "preciousness" in the carefully wrought pictures they guard. The "Enamel Picture in Silver Frame with Doors" again illustrates this idea; here the tones are chiefly of beautiful pinks and crimsons against a dark background, the note of golden yellow in the hair perfecting the harmony.

**N**EWCASTLE-ON-TYNE.—We give on the opposite page an illustration of the memorial statue of her late Majesty, Queen Victoria, by Mr. George Frampton, R.A., which has recently been set up in this city. In this, as in others of his public memorials, the sculptor has achieved a remarkable success.

specially composed and set to music, was sung by a choir of 1000 voices. At the Walker Art Gallery there is now being held an historical exhibition of the earliest sailing boats to the latest Atlantic liners, town charters, ancient documents, portraits, miniatures, pictures and prints, pottery, local coins, medals and tokens, and historical relics of all kinds. The medal here reproduced, struck in commemoration of this festival, is the work of Mr. Charles J. Allen.

H. B. B.

**E**DINBURGH.—Once in every five or six years the small but ancient Border town of Peebles is vitalised into holding an Art Exhibition, and the one just closed should have done something towards fulfilling the object of its promoters to awaken and strengthen an interest in pictorial work. The county contains several well-known collectors, and they lent pictures

**L**IVERPOOL.—In celebrating the seven-hundredth anniversary of the grant of Liverpool's first Charter by King John, a grand historical pageant, illustrating the annals and the industries of Liverpool in twelve periods from Druidical times down to the present day, was prepared by various committees of leading citizens under the chairmanship of the Right Hon. the Lord Mayor. To local artists and students of the School of Art was allotted the task of designing the processional cars and canopies, historical costumes, painted banners and tableaux, while the embroidered banners and shields and dresses thus designed were remarkably well executed almost entirely by the voluntary assistance of over 200 ladies. During the long procession of about 900 performers, dressed in costumes of the various periods depicted, a descriptive lyric ode,

## Studio-Talk

by Raeburn, John Phillip, Sam Bough, McTaggart, and Wingate, among the Scottish artists, while other schools were represented by James Maris, P. J. Clays, Neuhuys, Jacque, Munkacsy, Roybet, Sadee, and Sidaner. Of the last-named artist there were three very fine examples. In one of them—a winter scene—the artist makes the snow-covered ground sparkle with countless prisms flashing back the sunshine in an endless variety of colour, while in another *L'Après Midi*, one is made to feel the summer warmth and light of the open day, and yet be conscious that behind the sunlight there lies something that its potency has not revealed.



LIVERPOOL COMMEMORATION MEDAL  
BY CHARLES J. ALLEN



QUEEN VICTORIA MEMORIAL STATUE,  
NEWCASTLE-ON-TYNE BY G. FRAMPTON, R.A.

In two seascapes William McTaggart gives evidence of a capacity for the rendering of water in motion that no Scottish artist has equalled. Mr. McTaggart does not take kindly to Academy Exhibitions, neither in Scotland nor elsewhere, and it is mostly at provincial shows that one has the opportunity of seeing his work. In his *Ground Swell*, *Carradale*, this faculty of depicting motion is strikingly evidenced in the painting of the sea and a fishing-boat with figures. It is shown with no less effect in his *Seashore*, with the waves raised by a north wind breaking on the beach. The wave modelling is so free, the lines so broken and interrupted, and yet each filling its place, the work altogether so suggestive in its broad impressionism, as to convey the idea of the living force of the boundless ocean in language that is unmistakable. In another contribution Mr. McTaggart reverts to a type of subject he was wont to treat in the earlier

## Studio-Talk

part of his career, but the manner of its handling shows how greatly the artist's style has changed.

Recently-painted portraits of Sir Walter and Lady Thorburn by E. A. Walton were the other outstanding features of the Exhibition. In his three-quarter length of Sir Walter, Mr. Walton has executed one of his most characteristic works, but in that of Lady Thorburn he has failed to blend the colour in the painting of the face sufficiently, with the result that the tone is disagreeably degraded.

In celebration of its jubilee the Edinburgh Architectural Association recently held an exhibition of architectural drawings in the Royal Scottish Academy Galleries. Though the main idea was to focus the architecture of Edinburgh during the last fifty years, the line was not drawn very strictly, and roughly the collection might be said to be representative of Scottish architecture in the Nineteenth Century. It showed that architecture must be accorded no insignificant place in any record of that period of

the life of the country. The work of David Bryce and Playfair naturally occupied a prominent place, and present-day architecture was well represented by Sir Rowand Anderson, the designer of the New University and McEwan Hall, and Hippolyte J. Blanc, whose *chef d'œuvre* is the handsome Coats Memorial Church, Paisley. Some years ago Edinburgh, in her zeal for city improvement, demolished several notable examples of fine old Scottish domestic architecture, but happily a more enlightened spirit is now manifest in an attempt to conserve what is artistic.

A. E.

PARIS.—Paul Renouard is, without doubt one of the most attentive observers of contemporary life. His colossal *œuvre* forms a living repertory of the events of his time, noted with an absolutely indefatigable zeal. Nothing could be of greater value to us than these drawings, instinct as they are with life, energy, and *spiritualité*; they constitute, as it were, the note-book of a fertile artist, whose very life and breath are involved in his work. One calls to



“THE REHEARSAL”

BY P. RENOUARD



“THE STAGE CARPENTER”

BY P. RENOUARD

mind the wonderful series he did for the Exposition Universelle in 1900, and that of Liège. In both are to be found not only studies of crowds but remarkable individual portraits, for Renouard is equally apt in delineating large assemblages of people and in individual portraiture. The two works here reproduced are a fresh affirmation of this; in his figure of an old man, this modern artist is seen to possess the exactitude of detail and precise draughtsmanship of a Memling or a Van Eyck.

The great exhibition of the works of Chardin and Fragonard organised by M. Armand Dayot at the Galerie Petit has been an entire success. Well represented as both of these admirable masters are in our national collections it was nevertheless unusually interesting to find here pictures lent by such great collectors as M. Groult and M. Henri de Rothschild. In addition, an opportunity was afforded of admiring the collection of Fragonard's drawings belonging to the Besançon Museum. We shall presently devote a more detailed study to this signal manifestation, which has met with unprecedented appreciation on the part of the Parisian public.

France just now possesses a galaxy of delightful humorists, and so the idea of organising a salon to be consecrated entirely to their works was particularly felicitous. Léandre, whose pastels have formed the subject of an article in *THE STUDIO*, exhibited on this occasion some of his excellent portraits in which, besides conveying a striking likeness of his subjects, he has vividly accentuated their humours, yet without indulging in grotesque exaggeration. Forain in his *Impressions d'Audience* has, like his great predecessor Daumier, found a subject for his raillery in the inequalities of the administration of justice. His satire is almost dramatic in its incisiveness. On the other hand Faivre, who aims his shafts at the medical faculty, is extremely droll. Less personal than those I have named, Guillaume, too, makes some happy hits; Abel Truchet is a shrewd observer of Bohemian life, and Devambe excels in the most audacious foreshortenings.

The number of these humorists is legion, and there are few among them who cannot lay claim to truly personal gifts. It must suffice to mention the names of Gerbault, Bac, Ricardo-Florès, Hermann-Paul, Losques, Métivet. One of the greatest successes of this most interesting exhibition was Caran d'Ache with his toys—these are extremely simple in effect, but executed with so much originality and *esprit* that they are bound to become popular.

The Salons as usual closed their doors at the end of June, at which date the artistic season in Paris virtually terminated. An excellent show, however, which called for a visit was one held at Blot's, in the Rue Richepanse, consisting of paintings by certain talented artists, such as Francis Jourdain, Morisset, Urbain and Maudin, and there were also shown some delightful figurines in wood.

## Studio-Talk

The Salon d'Automne promises us a double treat this year. In one of the galleries we shall have a retrospective exhibition of Carpeaux, which is being organised by M. Sarradin with the cooperation of Mme. Carpeaux; then, as a sequel to the Russian Exhibition of last year, we shall have an exhibition of Belgian paintings, comprising more than 450 works, distributed over three rooms of the Grand Palais. M. Octave Maus, the distinguished president of the Libre Esthétique, is ardently devoting himself to this scheme.

Paris owes a new exhibition gallery to the intelligent initiative of M. Munzi, the energetic editor of "Modes" and various other journals. In point of size and lighting it is certainly the finest in Paris, and it is a pity arrangements were not made to hold the Chardin-Fragonard exhibition there.

H. F.

**B**ERLIN.—Prof. Alfred Grenander, of whose interior designs several examples are here given, was called from Sweden to teach architectural drawing and sketching at the Royal Arts and Crafts School here. He is an excellent master, whose school bears a stamp of its own. His works prove that full scope is given to individualism, but a kind of modernised classicism is the common feature. The exactness and discretion of his methods have procured him important commissions from municipal authorities. Just now he is again building an underground railway and stations for the West End of Berlin. Prof. Grenander has built and furnished a good many houses; he is in the modern term "Raumkünstler" (artist for space) and "Innenkünstler" (artist for interiors). We must not seek imaginative revelations where commonsense is the guide. Practicability in the

garment of taste is Grenander's ideal. He therefore cultivates straightness and parallelism. His ceilings and walls, his furniture and lighting apparatus, are treated with some of the soberness of the engineer. Yet the æsthetic is also active in him, and asserts itself in softening and embellishing; vertical lines are therefore sometimes gently inclined, and strong colours tempered. The logician cannot resist the temptation of the graces. J. J.

**B**ARCELONA.—The building in which the recent exhibition of fine and applied art was held consists of a great central hall, devoted to the larger pieces of sculpture, and a number of side-lighted rooms leading off it and given up almost entirely to the decorative arts, etchings and water-colours. Above these rooms run a series of galleries with good top lighting, which were devoted almost entirely to the oil



HALL OF HOUSE IN BERLIN

DESIGNED BY PROF. A. GRENANDER  
EXECUTED BY SIEBERT & ARZENBERG



SITTING-ROOM

DESIGNED BY PROF. ALFRED GRENANDER  
EXECUTED BY A. S. BALL, BERLIN



HALL

DESIGNED BY PROF. ALFRED GRENANDER



EXHIBITION ENTRANCE

(See Berlin Studio-Talk)

DESIGNED BY PROF. ALFRED GRENANDER  
EXECUTED BY A. S. BALL, BERLIN

paintings. A number of rooms were allotted to different nationalities, but our remarks must, owing to limitations of space, be confined to the Spanish contributions.

Beginning with the Salon Reina Regente, one first noticed the canvas of Rodriguez Acosta, *The Seagull*, representing a young girl in a kitchen, surrounded by culinary impedimenta, the bright timid eyes of the girl being accountable for its title. There is much charm in the simple, broad treatment, which is combined with great richness of colour. Next this was another work by the same artist, *Lolita*, noticeable for its refined treatment and absence of loading of paint, a harmony in grey and gold. There is a delightful swing and go in the figures of the two girls in J. Mongrell's *Costumbres Valencianas*, but the composition, however, is not quite happy. The fruit-pieces of Julia Alcdye disclosed careful study and rendering of bloom on fruit.

A large canvas by Eugenio Hermoso, depicting a band of young peasants returning from a well, each laden with a bright earthenware jar, arrested

attention by its absolute joyousness. The whole key was very high, and, perhaps, over bright in colour. An absolute contrast was seen in a snow scene by J. Morera—snow-covered roofs against a snow-laden sky, a dark fountain, and dark muffled-up figures in the foreground. Here the tones were quiet, the paint simple but refined, and the sense of atmosphere achieved by quiet direct painting being such as to make this one of the finest landscapes in the exhibition. Ricardo Urgell's sombre piece of painting *Barcelona Market Place* offered a contrast with the brighter landscapes more in evidence, such as those of Aureliano de Beruete, whose clear brilliant tones are so fine in their values. In his *Escaped Bull* P. Uranga conveyed a clever effect of artificial lighting: the feeling of movement and panic were admirably suggested. Nonell's three large canvases—seated figures of peasant women—had a wall to themselves. His style is large, and in a curious manner suggests sculpture, probably owing to the bold drawing and directness of intention as well as rather massive modelling of the figures. Raurich showed a grey landscape, *Solitude*—a restful and refined work.



## Studio-Talk

Amongst other noticeable landscapes in the Spanish section were those of A. Casas; a brilliant garden scene by this artist giving a wonderful feeling of heat in its bluey-violet sky. Then there were some curious and eccentric works by J. Mir, showing sometimes, as in his *El Roca de l'Estant*, cool rocks surrounded by limpid pools; at other times, as in *Els Arbres Alts* (The High Trees), buildings visible through the stems and leaves, the whole treated with such a mosaic of spots of brilliant fantastic colour, that one seemed to be looking at some production of grotesque Japanese design. Two such absolutely opposed styles are somewhat remarkable in one man. Rusiñol sent several interesting tree subjects, and *The Rainbow* of S. Regoyos showed a clever and effective manipulation of light, while E. Galwey's white-blossom trees, seen against a deep-blue sky, revealed much charm of treatment and colour.

In J. M. Tamburini one found an idealist. His *Jésus Infant* was marked by refinement of colour

and restraint of treatment, combined with a poetic conception of his subject. Next to this was L. Barrau's *Café de Marina*, a realistic café scene, with curious effect produced by the reflection of green trees on the shining marble of the café table. Another interesting effect of reflection was to be noticed in M. Feliu's study from the nude—a young girl lying on a sofa with the flickering light from an unseen fire reflected on her head and shoulder; the effect somewhat bizarre certainly, but the quality of paint fine. Entirely different in treatment was E. Casals' *Un Rapto*, an admirable piece of construction, colour, and handling.

Almost an entire room was devoted to the works of Ramon Casas. The place of honour was occupied by his large equestrian portrait of King Alfonso XIII., exhibited at the New Gallery last autumn. Fine though it is, the sketch for it, made from the life, which was hung exactly opposite, is infinitely finer. The paint is quite thin and slight, but the work is that of a master, and there is not



INTERIOR

(See Berlin Studio-Talk)

DESIGNED BY PROF. ALFRED GRENADE  
EXECUTED BY A. S. BALL BERLIN



SELF-PORTRAIT

BY EMIL SCHNEIDER

one useless touch on the whole canvas. Zuloago sent thirty-four works, filling two entire rooms. Some of them have already been seen in London. Of his subject pictures, *Vendimiadores* was perhaps the finest; this is a massive composition, strong in colour and composition. His *Portrait of an Artist* was also admirable.

A. de Riquer's book-plate for the King of Spain, although a small work, must not be passed by. The design shows a crown upheld by dainty figures, with graceful garlands surrounding the Arms of Spain, and is in three colours. M. Feliu's drawings struck me as particularly strong and full of motion.

Passing to the sculpture section, the finest work was Joseph Llimona's figure of a young girl in white marble, so simply and tenderly treated, and so beautiful, that one

looks forward to seeing it in London. The same sculptor exhibited a fragment of a large and imposing group, which is to be placed in front of Barcelona University as a monument to Doctor Robert. Luciano Oslé also exhibited some fine work.

ISOBELLE DODS-WITHERS.

C OLOGNE.—In Germany, the over-production of art seems to day more appalling than ever—art, that is to say, which, while falling short of the high-water mark of pure artistic merit, is somewhat above the average. To those who know that true æsthetic pleasure is no more derived “from the conventional than from the eccentric,” it must therefore be welcome news that efforts are being made to restrict the limits of Art exhibitions to a reasonable number of works, selected from the best of the best. Germany can boast of a greater distribution of minor centres of culture than most countries; besides the capital towns of the various Federal States



“Siesta”

BY FRITZ BURGER



"TO SCHUBERT"

BY WALTER OPHEY

Darmstadt, Düsseldorf, Mannheim, Heidelberg, and other places, including smaller towns with Universities, preserve and maintain their own peculiar sphere of spiritual life, where occasionally even the strain of pure artistic feeling may ring out fresh and true.

By selecting from the best efforts of a select few what will make the best harmony within a limited space, we may gradually solve the difficult problem of a really modern art exhibition—an exhibition raised to a high level in quality, and necessarily (most happily, let us say) limited in quantity. This principle, put into practice with unflinching severity, means a wholesome reform, if not a revolution in the system of art and applied art displays. The result, if not immediately satisfactory to all concerned, must in course of time find its due reward in the recognition and

praise of those who care deeply for the progress of art and taste.

At Cologne this system has been well carried out in connection with the art exhibition now being held there. There have been private invitations only; the most eminent artists and craftsmen contributing a share to the *ensemble*. A sober, subdued tone seems to pervade the rooms; each picture, piece of sculpture, or other object is placed in harmonious relation to its neighbour and the general environment, though it must be said that a little more comfort in the way of chairs and

lounges would be an advantage.

The department of applied arts and "Raumkunst" is the chief feature resulting from the new arrangement. Here the system adopted is that of



"EVENING LANDSCAPE"

BY A. HÖLZEL

changing the exhibits from time to time: these "wechselnde Ausstellungen" comprising modern fans, glass, silver objects, metal and earthenware. Thus there have been or will be a breakfast table and a dinner table laid and equipped as for actual use; interesting contributions by Professors van de Velde and Olbrich; some domestic architecture by Olbrich and Paffendorf, a show of artistic photographs, posters, etc., each display lasting about a month.

Among the paintings proper, the older men, like Professor Hölzel, are as fresh as ever, but younger men are promising to come to the front, particularly in landscape. I may mention without prejudice to those unnamed, a fine moonlight effect entitled *To Schubert*, by Walter Ophey; *A Lady in White* by Robert Weise; *After the Storm* by Fritz Westendorp, and a Self-portrait by Emil Schneider. Among the small exhibits of sculpture some animal studies seem to prove that the interest and appreciation of animal life is gaining ground with Teutonic artists of the younger gene-

ration. There is a fatigued draught horse, *Das Arbeitspferd*, by Arthur Hoffmann, and some portrait busts by Heinrich Jobst, also a bust of *St. John the Baptist* by Kornhas, and the *Sandalenbinderin* by August Kraus, as well as a novel rendering of the *Rattenfänger* ("The Pied Piper of Hamelin") by Hengstenberg. W. S.



"ST. JOHN THE BAPTIST" (MAJOLICA BUST)  
BY PROF. K. KORNHAS



"AFTER THE STORM"

BY FRITZ WESTENDORP

**D**ÜSSELDORF. — Of all the German poets not one has so sung himself into the hearts of his own people as Heinrich Heine. And yet, one of the greatest living poets of all time, he has suffered as none other from an antagonism that has amounted to hate. His politics and his creed arouse a bitterness which even now find vent in a vindictive war against his memory.

Düsseldorf's claim to fame in the eyes of the world rests largely on having been the birth-place of Heine, and yet such has been the bigoted political and religious opposition, that all efforts to erect a public monument to his memory have failed, though the money was forthcoming. It is, however, due to the enlightenment of a few public-

## Studio-Talk

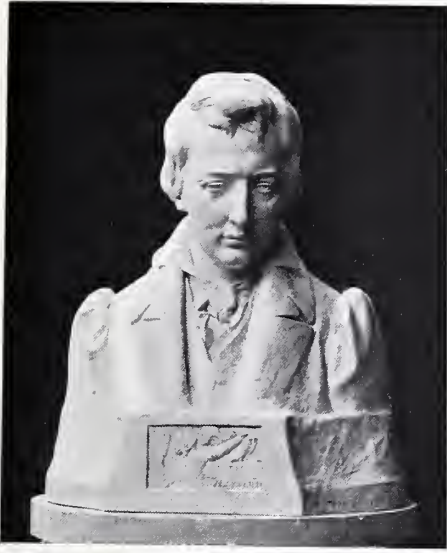

BUST OF HEINRICH HEINE  
BY ADOLF SCHMIEDING

spirited men that Düsseldorf has now, if not a public monument, at least a sacred spot where the name of her greatest son shall be held in reverence.

For years a bookseller of Leipzig, Frederick Meyer, was occupied in making an exhaustive collection of Heine literature, one representing all the first editions, all his earliest scattered writings, all other editions and translations, as well as all the known literature concerning Heine. It was a wise and fortunate decision to purchase this collection for Düsseldorf with a part of the money intended for the monument that could not be erected. This step was entirely due to the persistency and wisdom of these few men. It is also due to them that one room has been set aside in the new Town and State Library, which is henceforth to be known as the "Heine" room. This is a lovely, restful spot, quiet in colour and dignified in its simple architecture, and here this interesting collection has found a worthy resting place. And here, within a few weeks, there has also been placed on a fitting and simple pedestal, a bust of the poet by the Düsseldorf sculptor Adolf Schmieding.

To those who love Heine, to translate his poet's soul into his face would seem as hopeless a task as to clothe his immortal verse with the halting words and rhyme of a foreign language. But after the first glance at Schmeiding's Heine all doubt vanishes. It is indeed youth that has immortalised youth! The young sculptor has been inspired to portray the young poet, before mental and physical suffering had made of him a heroic martyr. It is the young poet of "Das Buch der Lieder" (The Book of Songs) Schmeiding has portrayed for us with ardent love and enthusiasm, using the Oppenheim portrait of Heine as the basis of his work. A beautiful poet's face with a high, narrow forehead, across which the hair falls in disordered locks; dreamy half-closed eyes with lower lids characteristically updrawn, and a whimsical, sad touch to the rather full lips, in which we recognise the genius whose wit suffering could not subdue. The face is full of a poetic, dreamy charm, and the faint shadow of a smile makes it all the more human. It is an appealing and noble work that all

lovers of Heine who make pilgrimages to the town of his birth should see. And yet the idle folly to deny Heine a memorial of mere stone—Heine, whose songs, long after that stone shall have crumbled away, will live in the hearts of the German people! MRS. JOHN LANE.

(Our notice of the Düsseldorf Art Exhibition is unavoidably held over.)



WOOD FIGURE BY LUDWIG PENZ  
(See Vienna Studio-Talk)



WOOD FIGURE BY LUDWIG PENZ  
(See Vienna Studio-Talk)

## Studio-Talk

VIENNA.—The carved wood figures here reproduced are the work of Ludwig Penz, a talented young craftsman, whom I have, I think, mentioned before in my notes.

The recent exhibition of the Secession was of more than usual interest, not only on account of the valuable work exhibited by its members but also for that contributed by the Society's guests, for, true to her traditions, she opened her doors wide for strangers. Among the latter, Charles Cottet and Henri J. Edouard Evenepoel deserve a first place. Over forty examples of Cottet were shown, a treat for which we were grateful to the organizers. One of his finest pictures is the *View of Pont en-Royans*, a work exquisite alike in tone and conception. His pictures of Brittany and the Breton peasantry, were also highly appreciated. Scarcely less interesting were the works of the Belgian master, Evenepoel, who died in Paris in 1899. Among other guests, Max Slevogt, of Berlin, was well represented by five works; Artur Kampf, also of Berlin, by some portraits and other works; and Hans von Hayek, of Dachau, by one picture, *Alte Häuser am Hang*. Adolpho Levier and Wilhelm Legler, who were represented, the former by a lady's por-



WOOD FIGURE BY LUDWIG PENZ



WOOD FIGURE BY LUDWIG PENZ



WOOD FIGURE BY LUDWIG PENZ

trait, and the latter by several landscapes, are both of Austrian nationality, but domiciled abroad.

Among the "Secessionists" themselves, the etchings of Ferdinand Schmutzer, which were hung in the *Ver Sacrum* room, offered a good opportunity of following this artist's methods. Enormous as are the plates he manipulates, he succeeds in bringing out the finest tones. Among these etchings of his was a characteristic portrait of the artist's mother, portraits of Joseph Kainz, the celebrated actor, Burgomaster Dr. Lueger, a lady seated at a piano, several coloured etchings, bits of architecture (including some from Oxford and Chester), and some *genre* subjects.

Among landscape painters Ludwig Sigmundt takes a prominent place. His country scenes show his remarkable power of minute delineation, and in common with his garden pictures testify to the painter's loyalty to nature, whose beauties he interprets with a truly personal charm and delicacy of touch. An interesting example of his work is *Die Alte Stadt* (The Old Town), here reproduced as a coloured supplement. Adolph Zdrzila



"THE OLD TOWN," FROM THE OIL PAINTING BY LUDWIG SIGMUNDT.





## Studio-Talk

(Troppau) in his *Mill-pool* gave us a lovely piece of country life. Richard Harlfinger exhibited some Viennese scenes which show great promise; Leopold Stolba some landscapes; Alois Hänisch, *A Summer Day, after Rain*, and some really delightful bits of still life. Ferdinand Andri only sent one picture, *Daybreak*, a mystic motive widely different from his usual work. Otto Friedrich's bits of mountain scenery and lakes are full of feeling. Anton Nowak, too, seeks his motives in the high mountains, his *Forge at Filzmoos* being a characteristic work.



WOOD FIGURE BY L. PENZ

Turning to the artists who do figure subjects, Maximilian Lenz, Max Liebenwein, Josef Mehoffer, Theodor Axentowicz, Rudolf Jettmar, and Ernest Stöhr, were all well represented. Friedrich König, in his *Sleeping Amor*, contributed

a fine example of his imaginative work. Rudolf Nissl, Walter Fraenkel, Alfred Offner, and Oswald Roux must also be mentioned, as also Fredericke von Koch, Angela Ella Adler, and Helene Scholz, three gifted ladies, the last-mentioned a sculptor. Nor must I omit to name Rudolf Bacher's three portraits of gentlemen, all life size and full of characterization.

Anton Hanak's marble bust *Magdalena*, several heads from the same model in different attitudes, by Ivan Mestrovic, and Alfred Hoffmann's bronze statue *Jugend* were notable contributions to the plastic section, to which also Rudolf Bacher, just mentioned as a portrait-painter, contributed a bronze bust of an aged lady—a relation of his.

A. S. L.



"THE FORGE AT FILZMOOS"

BY ANTON NOWAK

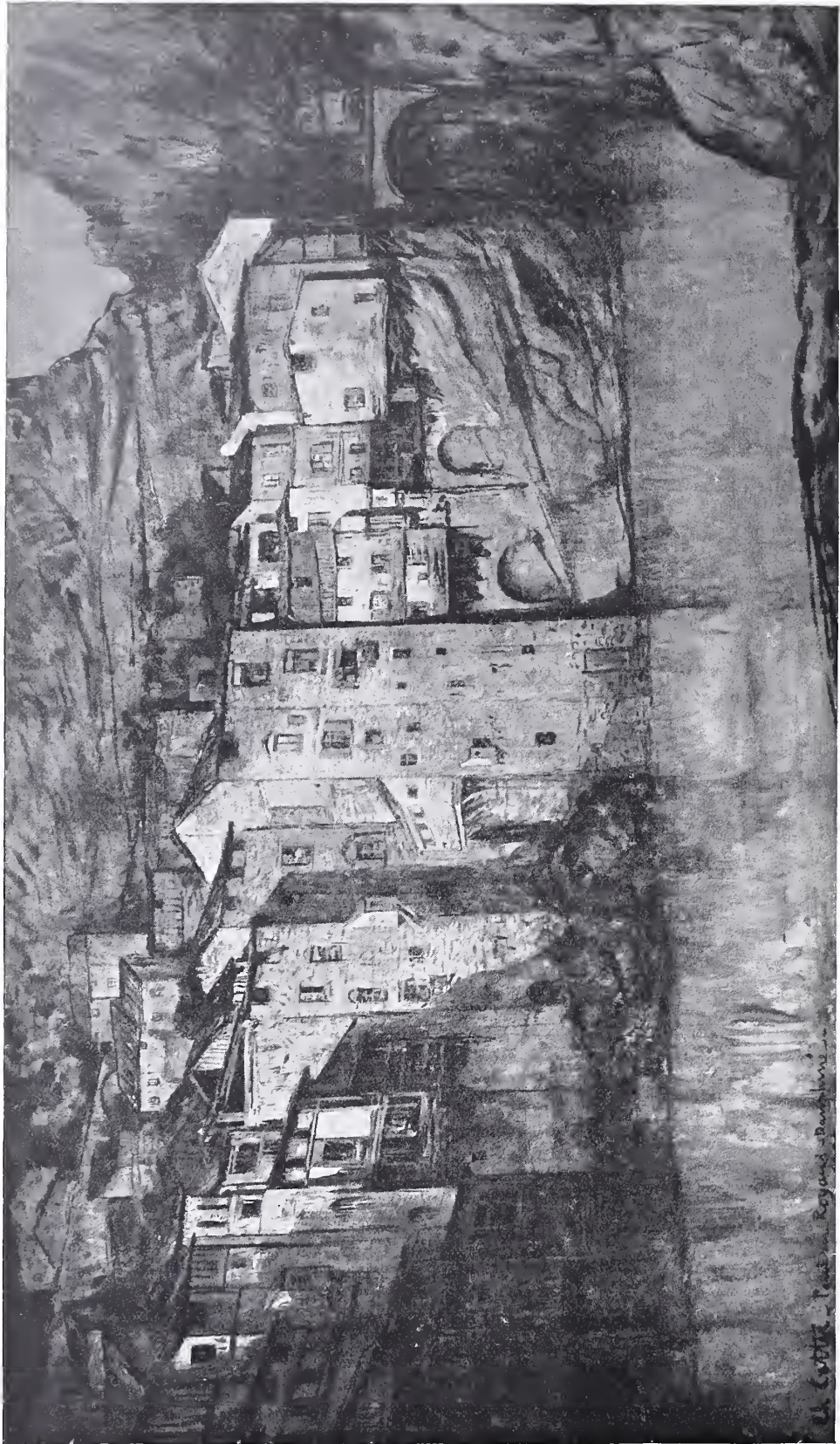

“VIEW OF PONT-EN-ROYANS”  
BY CHARLES COTTET

## Studio-Talk

**S**TOCKHOLM.—Mdlle. Ruth Milles, like her brother, the eminent Swedish sculptor, Carl Milles, of whom I shall have more to say anon, has studied some time in France. The accompanying illustrations prove her to be an artist possessed of a most charming grace of line and grouping, in many cases coupled with an almost tender sincerity,

and more often than not with the perhaps less feminine but not less desirable quality of modern breadth and freedom. The work of Mdlle. Milles betrays an observant and appreciative eye, and she seems to be singularly happy in the choice of her subjects and models.

G. B.



“THE YOUNG MOTHER”  
BY RUTH MILLES

nor Stefani devoted himself to organising special individual shows, among them one of Sartorelli's and another of Grosso's works. With exquisite taste and true knowledge, he has now brought about this year's exhibition, the subject of these notes. Let us first of all say a few words about the men who are no longer with us.

Antonio Fontanesi, who died some twenty-five years ago, was represented by three landscapes full of vigour and grandeur. He obtained very striking results by using, as groundwork on a white canvas, a transparent



CARVED WOOD FIGURE BY L. PENZ  
(See Vienna Studio-Talk)

**B**UENOS AYRES.—  
Argentine, till quite recently a virgin soil for art, promises to become one of the best art markets in the world. This is chiefly due to an Italian, Signor F. Stefani, who has educated the taste of the people and greatly influenced the public in that direction. Having organised several art exhibitions, Signor



“RETURNING FROM CHURCH” BY RUTH MILLES



"PEASANT WOMAN" BY RUTH MILLES  
(See *Stockholm Studio-Talk*)

golden-brown hue, on which the right colour is afterwards laid, thus achieving most surprising effects without ever falling into mannerisms. Particularly admirable are his skies, produced with most simple means and without any display of high-flown technique. Mosé Bianchi was a disciple of the school of Hayez. He quickly managed, however, to emancipate himself from everything that was purely academic, and thus freed himself from old prejudices. Beginning with the rigid formularies of a school founded largely on pedantry, he gradually felt the need of adding to the historical picture some episode from actual life. His two paintings here exhibited, *Ritorno alle Capanne* (The Return to the Huts), and *In Brianza*, are certainly remarkable when the origin of this artist is taken into consideration.

In Conconi's work the influence of his contemporaries can be seen, and especially that of Cremona. His chief characteristic is a contempt for everything that is merely conventional, and he willingly sacrifices technique for expression. Cremona is very strong in *chiaroscuro*, and for this reason his crayon drawings, now very rare, are greatly sought after. Palizzi, the animal painter, introduced bold innovations into the Neapolitan school. His little painting of a she-goat is a precious piece of work. We must not omit to mention Piccio, whose auto-portrait and sweet *Madonna* breathe the true modern spirit. In the paintings of Signorini the most remarkable trait is the grandeur of his colouring. Up to the last years of his life he was a gallant fighter of the Tuscan school—the "Macchiajuoli" ("stainers") as they were called.

And now let us pass to living artists. Fragiaco is—as he always has been—admirable in tone and poetic feeling. Mysterious evening voices, soft twilights, speak in his landscapes, and a sense of sadness seems to pervade his canvases. In *Alba* (The Dawn) one sees Venice at daybreak with its street lamps still lit; the whole is filled with an exquisite but robust feeling for truth, the vision of a sensitive soul. Equally worthy of note were his *Piazza San Marco* and his *Notturmo*. Guglielmo Ciardi, a distinguished and vigorous painter, keeps his place amongst the leading Italian



"THE LITTLE GOOSEHERD" BY RUTH MILLES  
(See *Stockholm Studio-Talk*)



“THE FIRST SNOW”

BY BARTOLOMEO BEZZI

landscape painters. His son Joseph was represented by a painting named *Alla Fontana* (At the Fountain)—a Venetian subject.

Bartolomeo Bezzi has a lyric nature, and in simple accents sings to us of the quietness of the lake, the colour of the skies, and the impression that one experiences on seeing the first fall of snow. He excels in the graduation of tones. Sartorelli, who has had already a show of his own at Buenos Ayres, had on this occasion two pictures which revealed him at his best. That ever-young painter Delleani, of Turin, with his studies, which are little masterpieces, sounded the sincere and joyous note which fittingly represents the Piedmontese landscape school. Miti-Zanetti well maintained the good reputation he has established.

Concerning the figure painters, I must first of all mention the sympathetic and energetic Mancini, whose strength lies in portraying individuals in their natural attitudes. Not only for this reason, but because of the intense vitality

of his work and the characteristic impressions he gives to his heads, I consider him to be the first portrait-painter of modern Italy. He has had the bad fortune—I should prefer to say the good fortune—of not being a fashionable portrait-painter, owing perhaps to some technical eccentricities of his, which, however, only reveal his almost fanatic tendency to reproduce the real, with that fidelity that is the most enviable gift of portrait-painters of any time.

Michetti is a pure realist who draws his inexhaustible form from nature. His *Voto* (The Vow) is an ornament to the National Gallery of Rome. In the present exhibition there were three studies for this work, a charming figure of a girl, a vigorous auto-portrait, and a splendid study for *La Processione dei Serpenti*.

At the other extreme there is Boldini, who, with a firm brush, depicts the nervousness of the modern woman and the rustling of her dress. Besides his elegant *Miss Mary*, he was represented by his

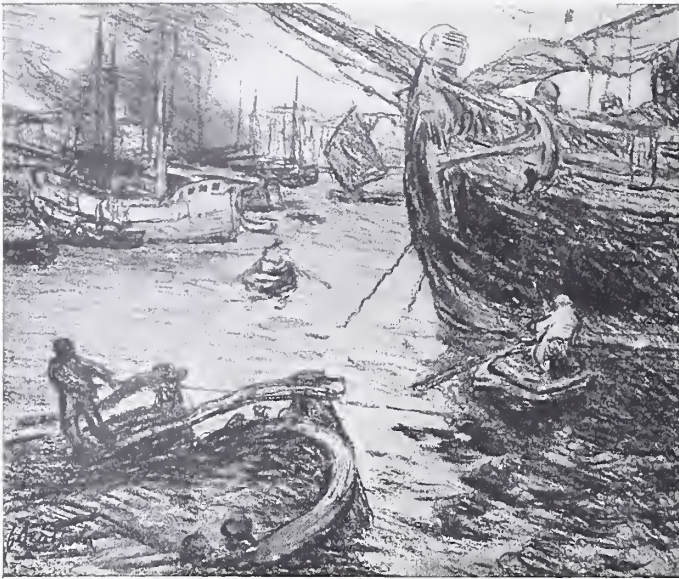

“ON THE GUIDECCA”

BY FERRUCCIO SCATTOLA

characteristic *Suonatore di Trombone* (The Trombone Player), painted on a bluish-grey background.

(Life), representing some women nursing their children, the keynote is a serene calm.

In Grosso we notice a great virtuosity, such as makes us forget the occasionally superficial character of his work. Painting is to him a true enjoyment, altogether devoid of asperity. Silk dresses, with a tendency to yellow and white, are painted by him with a master stroke, full of technical skill. I must mention also Sartorio, Fattori, and Alberto Pasini who worked with great success in Egypt. Among the young men there is Scattola, a fine colourist, and Selvatico, a most refined portrayer of feminine emotion.

As is always the case, sculpture was somewhat of a Cinderella at this exhibition, though it was here represented by some characteristic works of great artists, like Gemito, Bistolfi, Trentacoste, Calandra and Rubino.

The “clou” of the exhibition was the room devoted to Ettore Tito, who, after the signal success achieved at the Milan Exhibition last year, managed, with his marvellous activity, to produce a collection of



“NINA”

BY LINO SELVATICO



"LA VITA." BY ETTORE TITO

Tito excels in delineating the female head, and he sent to this exhibition one of the best specimens of the kind. Among other paintings of his which were shown on this occasion, there was a sea-piece in which the blue sea is reproduced with more sincerity and force than I remember to have seen in any other painting. The lines of waves seem endless, they come on, one over the other, foaming and roaring, towards the onlooker, lightened up by the reflections of the setting sun. In *L'Alzaia* Tito was seen to advantage as an animal painter.

One must not forget, as I said on another occasion, that Tito is one of the few Italian artists who know how to treat the nude in the open air, his modelling being remarkably bold, yet entirely free from mannerism. I was therefore pleased to see in this show some studies, full of life and action, of boys bathing in the sea or lagoon. Nor must I omit to name his *Leda*, a picture vibrating with light and life.

L. BROSCH.

## REVIEWS AND NOTICES

*Poets' Country.* Edited by ANDREW LANG. Illustrated by FRANCIS S. WALKER. (London and Edinburgh: T. C. & E. C. Jack). 21s. net.—In choosing his collaborators for this new study of the environment in which the great English poets produced their masterpieces, the editor has shown his usual tact and discretion, each of them being specially fitted to deal with the branch of the subject entrusted to him. Mr. Lang has himself dealt with Scott and Shelley, whilst Mr. E. Hartley Coleridge has treated his great namesake, as well as Wordsworth and Byron; Professor T. Churton Collins, Milton, Dryden, Goldsmith and the minor poets; the Rev. W. T. Loftie, Chaucer, Goldsmith, Keats and Spencer, and Mr. Michael Macmillan, Burns. In spite of all that has already been written on the poets, each of these true experts in criticism and literary style has either something fresh to say or is able to present long accepted truths in an original manner, as when Mr. Lang remarks that to get at



“UNDER THE PERGOLA”

BY ETTORE TITO



## Reviews and Notices



“THE TROMBONE PLAYER”

BY GIOVANNI BOLDINI

the truth of Shelley's poetical relation to Nature it is only necessary to reverse all that he has already said about Scott; Mr. Coleridge observes that Coleridge was country-born but town-bred; professor Collins likens Tennyson's descriptions to exquisitely finished cameos, and Mr. Loftie humourously observes in his essay on Keats at Enfield, that the operation of church restoration was not invented a hundred years ago. It is somewhat to be regretted that the numerous illustrations of a book of such varied attractions should all be from a single hand, especially as, with some exceptions, notably in his renderings of the Vale of Health, Hampstead, and the Poet's Walk, Eton, Mr. Walker takes an essentially prosaic view of his subjects, ignoring the delicate and mysterious grey effects that are so characteristic of the atmosphere of the British Isles. His love of red often leads him astray, his reflections are not always true to Nature, and it is sometimes a little difficult to recognise his interpretations of familiar themes, such as Byron's Tomb, at Harrow, which, instead of being perched on the edge of a hill has the appearance of being in a flat, green field.

*Te Tohunga: The Ancient Legends and Tradi-*

*tions of the Maoris.* Collected and pictured by W. DITTMER. (London: George Routledge.) 25s. net.—Appropriately dedicated to the Right. Hon. R. J. Seddon, who during his long term of office did so much for New Zealand, this collection of the quaint and gruesome legends of New Zealand with their weird interpretations in black-and-white, will do much to clear up certain problems that have long puzzled the student of folk lore. At first repelled but later fascinated by the strange stories told him by the tattooed natives with whom he foregathered around their camp fires during his wanderings, Mr. Dittmer carefully wrote down all that he heard, and later endeavoured with varying success to give pictorial expression to his notes. Specially noteworthy are the Chant of Rangi-Nui, the Creation of the Stars, the Fight of Night and Day, and the Creation of New Zealand, the illustrations of which are less weirdly grotesque than those for instance of Tiki and the Creation of Hawaiki, in which the figures are mere caricatures of humanity.

*Three Vagabonds in Friesland with a Yacht and a Camera.* By H. F. TOMALIN. With photographic pictures by ARTHUR MARSHALL, A.R.I.B.A., F.R.P.S. (London: Simpkin, Marshall.) 7s. 6d. net.—The purpose of this delightful volume, as explained by one of the three “vagabonds” responsible for its production, is to divert rather than educate, and it must certainly be conceded that its primary aim has been fully realised, for the interest is sustained from beginning to end, the reader being kept constantly on the *qui vive* as to what is coming next. The “vagabonds” were evidently travellers of the best type, who left their insular prejudices—if they ever had any—behind them, made a point of getting into true *rapport* with the natives, the charm of whose unsophisticated ways they recognised, and met all the difficulties with which they had to contend with cheery brightness. Their experience proved how false is the libel that in matters commercial the fault of the Dutch is giving too little and asking too much, for they met with nothing but kindness from the countrymen with whom they were brought into contact, the result of course in a great measure of their own wisdom in not expecting too much. To them the human interest always forcibly appealed,

## Reviews and Notices

and they found it inexhaustible in the old-world farms and villages in which the simple people live, contentedly pursuing their archaic agricultural methods and lovingly tending the cattle on which the prosperity of their native land mainly depends. Even without the admirable photographic plates, of which there are nearly a hundred of typical indoor and outdoor scenes, portrait groups, etc., the book would be a valuable one, but with them it will take rank amongst the best illustrated volumes of travel that have recently appeared. The chapters on Volendam and Marken are especially fascinating, so clearly are the characteristics of the people, who differ greatly from the rest of their fellow countrymen, brought out, and some of the illustrations, notably *The Student*, *Tired Brothers and Sisters*, *The Watched Pot* and the *Zuyder Zee Fishermen* are true works of art, whilst the appendices on architecture, nature notes, etc., from the pen of Arthur Marshall give a kind of scientific background to the light and charming text.

*Studies in Pictures.* By JOHN C. VAN DYKE. (London: T. Werner Laurie. New York: Scribner.) 6s. net.—Written primarily for the guidance of his fellow-countrymen in their travels in Europe, these studies from the pen of the eloquent American writer will be found extremely useful to all students who would gladly distinguish between the true and the false, the inferior and superior, in art, yet distrust their own judgment, and are puzzled by the diversity of opinion met with on every side. Mr. Van Dyke is a most trustworthy guide, who knows what he is talking about, with a knowledge rare indeed even amongst those who enjoy a great reputation as critics. He has the intuitive sense that can never be acquired by those in whom it is wanting, enabling him to recognise at a glance the work of a master, and he imparts his information in clear incisive language, that can be as readily understood by the neophyte as by the accomplished scholar.

*The Discoveries in Crete, and their Bearing on the History of Ancient Civilisation.* By RONALD M. BURROWS. (London: John Murray.) 5s. net.—The literature of Cretan Archæology has been accumulating so much since Mr. Evans's pioneer discoveries initiated this profoundly interesting field of research a few years ago, that only the expert is able to keep pace with it. Entirely opportune, therefore, is this volume, in which Prof. Burrows reviews the chief results so far accomplished. His aim has been to make it a general introduction to the subject, suitable for the reader who has little, if any, knowledge of it, and to that end he has

avoided technical terms wherever possible. At the same time the needs of the student who intends pursuing the subject seriously have been provided for in the ample bibliography and detailed plan of the Palace of Knossos appended to the volume.

*Das Bildnis im Achtzehnten und Neunzehnten Jahrhundert.* Von Dr. JULIUS LEISCHING. (Vienna: Anton Schroll & Co.). Price 7 kr.—The portrait exhibition held last year at the Austrian Museum in Vienna, simultaneously with the German centennial exhibition in Berlin, gave ample opportunity for the study of portraits of the eighteenth and nineteenth centuries, though unfortunately neither England nor France was even fairly represented. Dr. Leisching, who is Director of the Moravian Industrial Museum at Brünn, was invited to lecture on this subject at the Austrian Museum, Vienna, and the work under consideration is an expansion of these lectures. The author writes in an interesting way, and treats at length of the great masters of the period in Germany, England, France, paying particular attention to the influence of Van Dyck, which, he says, shows itself strongest on the English masters, who were not only great artists of the brush, but who also well understood how to please. He shows, too, how great was Lawrence's influence on the Viennese artists of his day—on Daffinger, Danhauser, Amerling, Eybl and others, above all, Amerling, who went to England for the purpose of studying under the English master. The author gives full credit to Waldmüller, who, with Pettenkofen, ranks among Austria's greatest painters, and it can but be a question of time before he is recognised outside German-speaking countries. The work contains a number of interesting reproductions.

*French Furniture.* By ANDRÉ SAGLIO. (London: George Newnes.) 7s. 6d. net.—Copiously illustrated, well translated into English, and, with an exhaustive subject index, this new volume forms a useful addition to the Applied Arts Series. From the pen of a true expert on the subject of furniture, it deals exhaustively with the evolution of that of France, beginning with the results of the Roman invasion of Gaul, bringing the story down to the fall of the first Napoleon, and concluding with an eloquent prophecy of a new revival of decorative art, which the writer argues must be imminent because such a renaissance invariably follows a decadence.

*The Petit Trianon, Versailles*, is the title of a work which Mr. Batsford is publishing in three parts at one guinea net each. It consists of an extensive series of measured drawings, photographs, etc., of the palace of the Petit Trianon, which is

## Reviews and Notices

of especial interest to architects as being a complete example of French architecture of the best period of the eighteenth century. In addition to the drawings and photographs of the entire exterior and interior, the illustrations include a large selection of furniture, numerous details of iron and brass work, accompanied by descriptive letterpress and an historical account of the building. The authors are Messrs. James A. Arnott and John Wilson, architects, to whom we presume are due all the drawings contained in the work, with the exception of two or three by Mr. J. Douglas Trail.

A knowledge of equine anatomy is not, it is to be feared, a strong point with many artists who introduce the horse into their paintings and drawings, and some who even specialize in this direction have a good deal to learn. To all such may be commended a portfolio of drawings published in this country by Mr. Fisher Unwin, and in Leipzig by the Dietrich Verlagsanstalt (T. Weicher), under the title of *The Horse: A Pictorial Guide to its Anatomy* (£1 10s. net). It contains 110 drawings by Hermann Dittrich, beautifully reproduced in collotype, with explanatory notes by Profs. Wallenberger and H. Baum, translated by Prof. Sisson, of Ohio State University. The muscular and osteological systems are drawn with remarkable accuracy, and the work cannot fail to be of the utmost service to painters and draughtsmen.

The third volume of Arthur L. Jelinek's *Internationale Bibliographie der Kunstwissenschaft* (Behr's Verlag, Berlin, 15 mks.) contains the entries for the year 1904—more than five thousand in number. We regretted to see announced recently the death of the compiler of this extremely useful publication, but we trust that a worthy successor will be forthcoming to continue his work.

Mr. G. Owen Wheeler's *Old English Furniture of the Seventeenth and Eighteenth Centuries* (L. Upcott Gill, 7s. 6d. net) is in the main a reprint of an instructive series of articles written by him for "The Bazaar." The subject is one in which a large number of people take a keen interest, and those of them who are in need of advice and information about it will find Mr. Wheeler's book a reliable guide. Those especially whose knowledge is scanty will profit greatly by his exposure of some of the methods adopted by the faker. A large number of excellent reproductions of representative pieces, by great craftsmen of the epoch dealt with, accompany the letterpress.

The second edition of *Chaffers' Handbook to*

*Hall Marks on Gold and Silver Plate*, edited and extended by Christopher A. Markham, F.S.A. (Reeves & Turner, 6s.), contains upwards of 200 marks not before given, bringing the various alphabets up to the present time.

The "Golden Poets" series, published by Messrs. T. C. & E. C. Jack (2s. 6d. net per vol.) has received two further additions—*The Poems of Byron*, with an introduction at once biographical and critical, by Mr. Charles Whibley, M.A., and illustrations by A. S. Forrest, and *The Poems of Keats*, to which Mr. Arthur Symons contributes a critical study of the poet, while Mr. Edmund Sullivan furnishes the illustrations. Each volume consists of about 250 pages, and one among other excellent features is the clearness of the type.

*Practical Stencil Work*, the second of the "Decorator" series of Practical Handbooks, is a concise and lucid guide to designing, cutting, and application of stencils to different purposes. It is written by Mr. Scott-Mitchell, a lecturer at the City and Guilds of London Institute, and is illustrated by over a hundred examples of designs suitable for this process. The book is published by the Trade Papers Publishing Co. at 3s.

Although wood engraving in this country is now almost entirely employed for technical and trade purposes, in the United States woodcuts are still in demand for pictorial illustration, and in Germany also there is a fair demand for these. There is not much likelihood of any considerable revival of this craft, but those desiring information about the *modus operandi* to be pursued cannot do better than consult a little book published by Messrs. Dawbarn & Ward in their "Useful Art Series." It is entitled *Wood Engraving and Placard Cutting*, and in the latest edition is supplemented by an instructive article, written and illustrated by Chas. E. Dawson, on "Lino. Cuts: a New Method in Block making for Posters and other Bold Work; also for making Tint-blocks for Two-Colour."

The designing of wicker and cane furniture has hitherto received much more attention on the continent (particularly Germany and Austria) than in this country, where most of the work turned out is either commonplace or unduly elaborate and fanciful. We are glad, however, to see evidence of a marked improvement in this respect in the pages of an illustrated catalogue sent us by the maker of the "Dryad" Cane Furniture—Mr. H. Peach of Leicester. The furniture illustrated therein is much above the average, in general design and construction, of that met with in this country.

## The Lay Figure

### THE LAY FIGURE: ON CHOOSING A SUBJECT.

"I would much like to give some of you artists a little advice about your choice of subjects," said the Philistine. "So many of you seem to have no earthly idea of painting anything that is of the remotest interest to sensible people, that I cannot help thinking there must be something radically wrong with the artistic intelligence. Don't you ever think; or do you just put down the first thing, whether it has any meaning or not, that comes into your heads?"

"Fools rush in where angels fear to tread!" commented the Man with the Red Tie. "You are over-bold, my friend, to offer advice to your betters. What are your qualifications for the part you want to play? Do you know anything about art?"

"Do I know anything about art?" laughed the Philistine. "Of course I do. I know a good picture when I see one, and I flatter myself that I could pick out in a few minutes all the best pictures in any gallery that you could take me to. I am never in any doubt about the things I like."

"What a gift!" sighed the Art Critic. "You make up your mind at once, without hesitation? You decide off-hand what is good or bad, and it all comes quite easy to you?"

"Perfectly," replied the Philistine; "I can never see that there is anything to hesitate about. The good points of a picture are so evident that any intelligent man can see them in a moment. What puzzles me is that such a lot of artists should be so incapable of grasping what is to me a simple matter of course."

"Would you be so kind as to explain," said the man with the Red Tie, "what are the good points which are so evident in the pictures you admire? What is it that appeals to your infallible judgment and satisfies your taste with such electrical suddenness?"

"You are ready to seek my advice, after all," chuckled the Philistine. "I will tell you what I think. A good picture is, first of all, one that has a meaning and tells an interesting story; one that has a good subject, in fact. Secondly, it is one that is well painted and properly finished, not a mere mass of daubs and streaks of paint. Thirdly——"

"Oh, never mind about your thirdly," interrupted the Critic. "Your first point is quite enough to go on with. A picture, you say, should have a good subject, and so far I am quite with

you, for I hold that artists should exercise the utmost care in their choice of subject. But you also say that the picture should tell an interesting story. What do you mean by that?"

"I mean that it should illustrate some incident from life," replied the Philistine; "some historical event or some present-day occurrence worth making a note of. The people painted ought to be doing something serious or amusing; I hate to see them simply lolling about trying to look pretty."

"In other words, you want something of the snapshot type," said the man with the Red Tie; "a mere commonplace record of a bit of every-day life."

"Well, why not?" returned the Philistine. "I am sure I have seen many snapshots which were much more interesting than half the pictures you men paint."

"Interesting to you, no doubt," said the Critic, "because your vision is so limited that you cannot see anything that is not absolutely commonplace and ordinary. You have no idea whatever of any art that is not simply literal and unimaginative."

"But I tell you I have studied pictures very closely," cried the Philistine, "and I have really high ideals about them."

"Perhaps; but you have looked at them from only one point of view," answered the Critic. "You have narrowed everything down to the one notion that a good subject is merely one that reminds you of something you have seen; and you are so unobservant that you have seen nothing save those things which are not worth looking at. Therefore your complaint that artists do not paint what appeals to the sensible man means only that the subjects they choose are outside the range of your limited intelligence. The varieties of the good subject are infinite. An effect of light and shade, or of colour, an arrangement of lines and masses in a landscape, a subtle harmony of tones, all these may be subjects of the most notable importance and may be much more worthy of pictorial treatment than those scenes from real life, realistically set down, which you in your folly think so attractive. But because such subtleties are beyond you, you presume to lay down the law about matters which you have no right to discuss. You have in your mind a kind of picture pattern, a stupid convention to which you hold all art ought to conform. Ignorance, not sense, intolerance, not good taste, are the foundations of your argument, and you deserve no mercy for being so foolish. Go home, and try to realise how very little you do know."

THE LAY FIGURE.

# The Opinion of Dan Beard

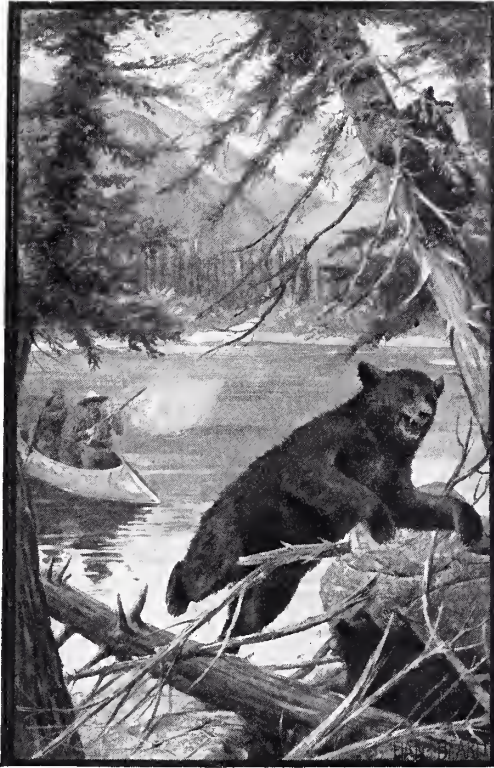

From COLLIER'S WEEKLY Copyright 1907 by P. F. Collier & Son

The drawing by Mr. Dan Beard that is reproduced above is typical of the work of this widely known illustrator and is one of many made upon Strathmore Drawing Board. Mr. Beard's opinion of Strathmore is that of practically every well-known illustrator in the country. He writes us:

"In my twenty odd years of life as an illustrator, it has not been my good fortune to have used any paper which equals the samples which you so kindly sent to me, either for wash or pen and ink drawings, and it gives me pleasure to be able to tell you so welcome a truth.

"Keep the standard up to the samples and you need have no fear for the popularity of the Strathmore Drawing and Illustrating Board among the illustrators and water color artists."

Strathmore Drawing Papers and Boards are made for brush, pencil, pen, crayon and charcoal. There are twenty different kinds, including our new Water Color Paper. Sold by most good dealers, but if not by yours, send to us for sample book and address of dealer who will supply you.

## Strathmore Drawing Papers Boards

Mittineague Paper Co., Mittineague, Massachusetts, U. S. A.

# WILLIAM J. LOCKE



## THE BELOVED VAGABOND *One of the Six Best Sellers*

*"One of the most complete, convincing and entirely delightful characters that have made their debut between book covers for a long time."*—NEW YORK TIMES.

## THE MORALS OF MARCUS ORDEYNE

*"By far the best thing he has done."*—DIAL.

AT THE GATE OF SAMARIA  
WHERE LOVE IS  
A STUDY IN SHADOWS  
THE DEMAGOGUE AND LADY PHAYRE

THE USURPER  
DERELICTS  
IDOLS  
THE WHITE DOVE

12mo. \$1.50 each.

## FOR THE WEEK-END

A LOVE STORY

By HANDASYDE, Author of "Four Gardens." 12mo. \$1.50

*"Only a woman would write such deep and intimate truth about the heart of another woman."*—LONDON STANDARD.

*"A passionate story of love—and innocent love, too,—in the Smart Set."*—LONDON SUNDAY TIMES.

*"Has a distinct character of its own. Reading that is good and alive."*—LONDON TRIBUNE.

*"A genuine story of passion. Managed with considerable skill and a good deal of delicacy and pathos."*—LONDON MAIL.

## THE WINGLESS VICTORY

*"The London Literary Success"*

By M. P. WILLCOCKS, Author of "Widdicombe." 12mo. \$1.50.

*"The character (of the heroine) is portrayed with exceptional skill, as are the portraits of the husband and Joanna, the Magdalen. The latter-named is a triumph."*—PHILADELPHIA PRESS.

*"The strength of keen analysis, vivid descriptive power and a characterization of the rustic population of Devon and Dartmoor fairly comparable with the work of Mr. Phillpotes and other disciples of the school of Thomas Hardy."*—DIAL.

*"Rises high above the level of common day fiction. Invites a second reading with a still further examination of and lingering over certain choice passages."*—NEW YORK EVENING POST.

## THE STRONGEST PLUME

By HUGH DE SELINCOURT. 12mo. \$1.50.

**T**HIS is the story of a girl who gradually comes to see that she cannot be purified from a moment's mistake by a lifetime's marriage. She touches life at its very heart, and gains at last the courage from her experience of life and death to stand by herself without the props of convention, which help the weak as much as they bruise the strong. The title of the novel is taken from the novel's motto:

*"The strongest plume in wisdom's pinion  
Is memory of past folly."*

*"Mr. de Selincourt deals with a problem quite worthy of serious consideration, frankly but restrainedly. Excellent studies of character."*—LONDON DAILY NEWS.

**JOHN LANE CO., 110-114 West 32d Street, NEW YORK**

Ready - Sept. 13.

THE

# MAULEVERER MURDERS



A DETECTIVE STORY BY  
**A.C. FOX-DAVIES**

JOHN LANE COMPANY, 110-114 W. 32d St. New York

*By the Same Author*

**THE DANGERVILLE  
INHERITANCE**

"A detective story of which Gaboriau might be proud."—LONDON POST

12mo, \$1.50

"Of the Wilkie Collins order."—NEW YORK TIMES

"Plenty of excitement."—DETROIT NEWS-TRIBUNE



## MEMOIRS OF ANN LADY FANSHAWE

Written by LADY FANSHAWE, with Extracts from the Correspondence of Sir Richard Fanshawe. Edited by H. C. FANSHAWE. Thirty-eight Full-page Illustrations, including four in photogravure and one in color.

8vo. \$5.00 net. Postage 25 cents.

THIS edition has been printed direct from the original manuscript in the possession of the Fanshawe family, and Mr. H. C. Fanshawe contributes numerous notes which form a running commentary on the text.

## RALPH HEATHCOTE

Letters of a Diplomatist during the time of Napoleon, giving an account of the Dispute between the Emperor and the Elector of Hesse. By Countess GÜNTHER GROBEN. Profusely illustrated.

8vo. Cloth. \$5.00 net. Express 25 cents.

## A SEA-DOG OF DEVON

A LIFE OF SIR JOHN HAWKINS. With an Introduction by LORD BRASCY and LORD J.EY-  
LAND.

Frontispiece. \$1.75 net. Postage 15 cents.

THIS book is the first attempt of a biography of Sir John Hawkins, one of the most brilliant of the merchant adventurers, generals at sea and naval statesmen of the Elizabethan era, the kinsman and mentor of Sir Francis Drake.

## ALFRED BRUNEAU

A Profusely Illustrated Biography by ARTHUR HERVEY.

LIVING MASTERS OF MUSIC SERIES.

12mo. \$1.00 net. Postage 8 cents.

"A model of what a brief biography of a living composer should be."—LONDON TRIBUNE.

"Capital and adequate."—LONDON STANDARD.

"Valuable."—EDINBURGH SCOTSMAN.

## THE ROMANCE OF KING ARTHUR

12mo. \$1.50 net. Postage 10 cents.

"In this volume Mr. Coultts has surprised us. A poet he was known to be. The discovery that he is also a dramatic poet comes unexpected. We wish that there was some chance of seeing it on the stage."

—LONDON TIMES.

## POETRY AND PROGRESS IN RUSSIA

By ROSA NEWMARCH.

With Six Full-page Portraits. 8vo. \$3.50 net. Postage 25 cents.

THIS book deals with an aspect of Russian literature hitherto neglected, including the works of the pioneers of intellectual progress.



POUSHKIN

**JOHN LANE CO., 110-114 West 32d Street, NEW YORK**



# REMBRANDT



*Illustration (Reduced) from Rembrandt, John Lane Company*

## THE INTERNATIONAL STUDIO SPECIAL DOUBLE NUMBER, 1907

Illustrated with Seventy Plates in Color and Photogravure

"The new method of reproduction combines all the advantages required for a really worthy reproduction of the old masterpieces, and gives the depth of tone and the velvety appearance that distinguished the mezzotints of English engravers of the eighteenth century."—*Dr. Bode, Director Berlin National Gallery, Greatest Living Authority on Rembrandt.*

BOUND IN GREEN BUCKRAM, \$5.00 NET.

EXPRESS EXTRA.

**JOHN LANE COMPANY, 110-114 West 32d Street, NEW YORK**

*In writing to advertisers, please mention The International Studio.*

PRESS OF REDFIELD BROTHERS, NEW YORK

# "TIFFANY FAVRILE GLASS"

MADE ONLY BY THE TIFFANY FURNACES  
LONG ISLAND, NEW YORK

The distinguishing name is Registered in the United States Patent Office, and is also protected by Letters Patent in Great Britain, France, Germany, Austria and Hungary.

Tiffany Favrile Glass exists under no other name.

Importers and Dealers are notified that the use of this name wholly or partly, in connection with any glass not made by the Tiffany Furnaces, is an infringement, and all persons so using it will be prosecuted.

*Sold in New York only by Tiffany & Co., Fifth Avenue  
and Tiffany Studios, Madison Avenue. : : : : : :*

TIFFANY FURNACES

LONG ISLAND, NEW YORK

## Artists' Materials

LEFRANC & CIE; P. FOINET FILS.  
BLOCKX



Oil Colors

And all the  
Prominent  
Makes

Canvas

A Special Feature

"Plasteline"

For Sculptors

A. C. FRIEDRICHS

169 W. 57th St., New York

Largest Retail Artists' Material Dealer in the U. S.

Catalogue Free

LONDON

OSAKA

BOSTON

YAMANAKA & CO.

254 FIFTH AVENUE,

NEW YORK

WORKS OF ART  
FROM THE FAR EAST

Rare Old Paintings and Color Prints a Specialty



Frink's Portable  
Picture Reflectors

For electric light, meet all requirements for lighting pictures. Every owner of fine paintings could use one or more of these portable reflectors to advantage. The fact that so many have ordered the outfits for their friends is proof that their merits are appreciated. Height, closed, 51 inches; extended, 81 inches. The light from the reflector can be directed at any picture in the room and at any angle.

I. P. FRINK, 551 Pearl St., New York

GEO. FRINK SPENCER, Manager  
Telephone, 82 Worth

*In writing to advertisers, please mention The International Studio.*

The  
**INTERNATIONAL  
 STUDIO**

Reg. U. S. Pat. Off.



**JOHN LANE COMPANY**

110-114 West Thirty Second Street

• NEW YORK •

§ Monthly • 50 cts. ¢

Yearly Subscription \$ 5<sup>00</sup> Post paid

# Art Students' League of New York



## SEASON

SEPTEMBER 30, 1907, to MAY 23, 1908

Kenyon Cox  
F. Luis Mora  
Edwin C. Taylor  
Rhoda Holmes Nicholls  
Augustus Vincent Tack  
Frank Vincent DuMond  
Thomas Fogarty

Wallace Morgan  
Everett Shinn  
George B. Bridgman  
Alice Beckington  
Charles Henry White  
James Earle Fraser  
William M. Chase

## CLASSES

LIFE	ILLUSTRATION
ANTIQUE	ANATOMY
MODELING	MINIATURE
ETCHING	COMMERCIAL DESIGN
COMPOSITION	PORTRAIT

Circulars on Application to

Art Students' League of New York

215 West Fifty-seventh Street, - New York, N. Y.

# HIGGINS'

DRAWING INKS  
ETERNAL WRITING INK  
ENGROSSING INK  
TAURINE MUCILAGE  
PHOTO MOUNTER  
DRAWING BOARD PASTE  
LIQUID PASTE  
OFFICE PASTE  
VEGETABLE GLUE, ETC.



Are the Finest and Best Inks and Adhesives

Emancipate yourself from the use of corrosive and ill-smelling inks and adhesives and adopt the Higgins' Inks and Adhesives. They will be a revelation to you, they are so sweet, clean and well put up.

At Dealers Generally

CHAS. M. HIGGINS & CO., Mfrs.  
Branches: Chicago, London.

271 Ninth Street, Brooklyn, N. Y.

# New York School of Applied Design for Women

200 WEST 23d STREET

(Incorporated 1892)

SPECIAL LIFE CLASS. ALSO SPECIAL COURSE IN  
DESIGN UNDER ALPHONSE MUCHA

Silk and Wall Paper Designing, Antique  
and Costume Sketch Classes, Historic  
Ornament, Architecture.

Apply to HELEN LOOMIS, Secretary

# BACK NUMBERS

*THE (ENGLISH) STUDIO*  
Vols. I to IX inclusive. Handsome Uniform  
Cloth Binding Complete, \$100.00 net.

*THE INTERNATIONAL STUDIO*  
Vols. I-XXVII inclusive. Being Complete  
File of Bound Volumes to February, 1906,  
inclusive, \$100.00 net.

*ADDITIONAL BOUND VOLUMES*  
Vols. XXVIII-XXXII. To Complete File  
up to November, 1907, inclusive, \$3.00 net  
per volume.

SEND YOUR BACK NUMBERS  
to the Publishers for Binding in Permanent  
Volume Form.

*Cloth Binding, Uniform with Series, \$1.00  
per volume. Four issues to each volume.*

BEST WORKMANSHIP. MOST REASONABLE RATES

JOHN LANE COMPANY

110-114 WEST THIRTY-SECOND ST., NEW YORK

MR.

# WILLIAM M. CHASE

writes us as follows

"I am better pleased  
with your colors, af-  
ter a thorough test,  
than any other  
colors I have used"

Write for booklet "Ullman's  
Manual of Artists' Colors"

SIGMUND ULLMAN  
C O M P A N Y

Park Ave. & 146th St., N.Y.

In writing to advertisers, please mention *The International Studio*.

# TIFFANY & CO.

Fifth Avenue and 37th Street, New York

## A Basis for Comparison of Prices

Tiffany & Co. always welcome a comparison of prices. While this applies to their rich as well as inexpensive jewelry, silverware, clocks, bronzes and other objects, it is possible for their patrons more easily to make comparisons on certain articles of silverware than on some of the more individual pieces from their stock. To this end the method of marking prices on Tiffany & Co.'s copyrighted patterns of

### Sterling Silver Forks and Spoons

At \$1.00 per ounce

furnishes exact information as to weights and values. These patterns are not sold through the trade or other dealers and each piece is of English sterling quality 925/1000 fine. Upon this basis prices per dozen range as follows:

Tea Spoons	-	-	-	-	dozen \$11 upward
Dessert Spoons	-	-	-	"	18 "
Soup or Table Spoons	-	-	-	"	25 "
Breakfast, Entrée or Dessert Forks	-	-	-	"	17 "
Dinner or Table Forks	-	-	-	"	23 "

Cuts of patterns sent upon request, also estimates for special sets to suit individual requirements

## Fifth Avenue New York

Tiffany & Co. 1907 Blue Book—a compact catalogue without illustrations; 621 pages of concise descriptions with range of prices of jewelry, silverware, clocks, bronzes, pottery, glassware and other objects suitable for wedding presents or other gifts—Blue Book sent upon request

# ANNOUNCEMENT

THE SUBURBAN HOME number of the ARCHITECTURAL RECORD will appear on the news-stands on September 25th. This is the ONE BIG SPECIAL NUMBER of the year. The price of this number will be the same as the regular edition, 25 cents per copy, so get your order in early, before the edition is exhausted.

If you will send us your year's subscription now we will send you the SUBURBAN HOME NUMBER free and start your year with the November number. Price of year's subscription, \$3.00.

Advertising Rates	Contracts for less than one year per issue			Year Contract
	Sixteenth Page	Eighth Page	Quarter Page	
	- - - -	- - - -	- - - -	\$6.00
	- - - -	- - - -	- - - -	11.00
	- - - -	- - - -	- - - -	19.00
	- - - -	- - - -	- - - -	36.00
	- - - -	- - - -	- - - -	60.00

ADDRESS  
 ARCHITECTURAL RECORD COMPANY  
 11 EAST 24th STREET, NEW YORK CITY

## The AMERICAN ARCHITECT AND BUILDING NEWS

A Weekly Journal of Constructive and Decorative Art. Now in its Eighty-ninth Volume.

A sample copy will be sent on request to readers of the International Studio

We shall be pleased to send also a price list of books published by us and an illustrated catalogue of the most complete and important work on colonial architecture that has ever appeared—"THE GEORGIAN PERIOD."

THE AMERICAN ARCHITECT (INC.)

Kimbel Building, 12 West 40th Street, New York City

# WINSOR & NEWTON, Ltd.

LONDON

New York Office and Salesroom 298 Broadway

OUR

ARTISTS' OIL AND WATER COLORS  
ARE THE WORLD'S STANDARD

ALSO, OUR

Illustration Board Pink and White Soft Rubber  
Waterproof Drawing Ink Nonpariel Drawing Pencil  
All Manufactured by W. & N. for Illustrators, Designers,  
Engravers and Lithographers, etc.

Should you not be able to obtain our goods we will send them direct.

SEND 3 CENTS FOR CATALOGUE

WHOLESALE ONLY

## Handbooks on the Fine Arts

(POSTPAID, 30 CENTS)

In ordering it is sufficient to mention the number which is prefixed to each book

Nos.

1. Warren's Half-hour Lectures on Drawing and Painting.
2. Rowbotham's Art of Sketching from Nature.
3. Rowbotham's Art of Landscape Painting in Water Colors.
4. Penley's System of Water Color Painting.
5. Carmichael's Art of Marine Painting in Water Colors.
6. Hatton's Hints for Sketching in Water Colors from Nature.
7. Merrifield's Art of Portrait Painting in Water Colors.
8. Day's Art of Miniature Painting.
9. Duffield's Art of Flower Painting in Water Colors.
10. William's Art of Landscape Painting in Oil Colors, with Instructions for the Mixing and Composition of Tints.
11. Murray's Art of Portrait Painting in Oil Colors.
12. Carmichael's Art of Marine Painting in Oil Colors.
13. Penley's Elements of Perspective.
15. Laing's Manual of Illumination.
16. " " (Companion to above.)
17. Weigall's Art of Figure Drawing.
19. Warren's Artistic Anatomy of the Human Figure.
21. Hawkins' Anatomy of the Horse.
23. Murray's Art of Drawing in Colored Pastel Crayons.
24. Goodwin's Art of Mural Decoration.
26. Groom's Painting on Glass for Magic Lanterns, etc.
27. Martel's Principles of Coloring in Painting.
30. Mogford's Instructions for Cleaning, Repairing, Lining and Restoring Oil Paintings, with a Chapter on Varnishing.
33. Robertson's Art of Etching on Copper.
34. Robertson's Art of Painting on China, with a Chapter on Terra Cotta Painting in Oil and Water Colors.
36. Wallis' Water Color Sketcher's Manual, containing Dictionary of Mixed Tints and Combinations of Water Colors for all Subjects in Landscape Painting.
37. Muckley's Flower Painting in Oil Colors (with Colored Illustrations).
39. Muckley's Fruit and Still Life Painting in Oil and Water Colors (with Colored Illustrations).
40. Robertson's Pen-and-Ink Drawing.
41. Delamotte's Trees and How to Draw Them.
42. Davis on the Interior Decoration of Dwelling Houses (with Illustrations of Colors Suitable for Rooms).
43. Taylor's Description of Modern Water Color Pigments, Illustrated with Washes of Seventy-two Colors, Gradated by Hand on Whatman's Drawing Paper.
44. Gullick's Oil Painting on Glass, including Painting on Mirrors, Windows, etc.
45. Cartlidge's Oil Painting for Beginners. A Manual of Elementary Instruction (with Colored Illustrations).

In writing to advertisers, please mention *The International Studio*.

## Modern German Sculpture

Compiled and Edited by A. SCHULTZ

A selection of the work of the foremost sculptors of the present day. This publication contains, for the first time, in most excellent reproductions, a comprehensive collection of the masterpieces of contemporary German sculptors.

The work offers an abundance of suggestions to the sculptor, and will certainly prove to be a very valuable material for the Art Student, Amateur and Connoisseur.

Three Series of 60 Plates each. In Portfolios.  
Per Series, \$14.00.

**BRUNO HESSLING CO., Ltd.**

No. 64 East 12th Street, New York, N. Y.

## VOUGA CELEBRATED FINEART STUDIES

Latest complete illustrated Catalogue, 30c. New Flower, Fruit, Figure, Landscape and Animal Studies—suitable for Oils and Water Colors. Discounts given in Catalogue.

M. G. PRICE, 359 West 118th St., New York



**Long Sang Ti & Co.**  
IMPORTERS

307 FIFTH AVENUE, Near 31st St.  
NEW YORK

Genuine Chinese and Japanese  
Objects of Art

Real Chinese Jade & Oriental Jewelry

Write for Illustrated Booklet A



**Misses Whittredge & Barrows**

Interior Decoration

General Decorative Work & Designing

4 WEST 40th STREET, NEW YORK CITY



**THE UNIVERSITY PRINTS**

1,500 subjects on Greek and Italian art. Size 5½ x 8 inches. One cent each or eighty cents per hundred. Send for Catalogue.

Dutch, Flemish and German Series in preparation.

Bureau of University Travel, 16 Trinity Place, Boston, Mass

## ART TUITION

### Eric Pape School of Art

REOPENS OCTOBER 1, 1907

Tenth Year—October 1, 1907, to June 1, 1908.

Head Instructor and Director, ERIC PAPE

No examinations for admission to any of the classes. Students begin by drawing from the nude and costume models as is done in the Paris academies upon which the school is modeled. Fine large studios.

**Drawing, Painting, Composition  
Illustration and Decorative Design**

Drawing and Painting from "life," separate classes for men and women. Portraiture, Still-life, Flower-painting, Water-color, Pastel, Composition, Decorative Design and Painting, Practical Design for Textiles. Illustration, Pen, Wash, Gouache, Poster and Book-cover designing.

**Morning, Afternoon and Evening Classes. Scholarships, Medals and Prizes.**

For Illustrated Circulars address the Secretary  
Corner Massachusetts Ave. and Boylston St., Boston, Mass.

# REMBRANDT



*Illustration (Reduced) from Rembrandt, John Lane Company*

## THE INTERNATIONAL STUDIO SPECIAL DOUBLE NUMBER, 1907

Illustrated with Seventy Plates in Color and Photogravure

"The new method of reproduction combines all the advantages required for a really worthy reproduction of the old masterpieces, and gives the depth of tone and the velvety appearance that distinguished the mezzotints of English engravers of the eighteenth century."—*Dr. Bode, Director Berlin National Gallery, Greatest Living Authority on Rembrandt.*

BOUND IN GREEN BUCKRAM, \$5.00 NET.

EXPRESS EXTRA.

---

**JOHN LANE COMPANY, 110-114 West 32d Street, NEW YORK**



# F. WEBER & CO.

ST. LOUIS, MO.

PHILADELPHIA, PA.

BALTIMORE, MD.

OLDEST MANUFACTURERS, IMPORTERS AND DEALERS IN

## ARTISTS' MATERIALS, DRAUGHTSMEN'S AND ENGINEERS' SUPPLIES

### SKETCHING MATERIALS

We carry the most complete line of Easels, Stools, Umbrellas, Oil and Water Color Outfits, Thumb Boxes, Umbrella Staffs, etc., etc.

**Air Brushes** and Air Brush Materials.

Everything for the Illustrator.

Complete assortment of the finest quality of **Artists' Brushes.**

**Herbutt's Plasticine** a finely prepared anti-septic composition modeling clay.

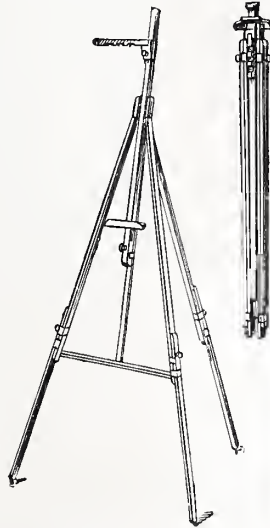

F. Weber & Co.'s Artists' Oils and Moist Water Colors. F. Weber & Co.'s "Students'" Moist Water Colors in tubes  $\frac{1}{2} \times 3$ ", made in 36 different colors.

Send for sample card of "Sphinx" and "Students'" Moist Colors.



A large variety of different qualities of Mathematical Instruments.



Works on Art for illustrators, Fresco Painters, Sculptors, Engravers, Lithographers and Textile Workers.

Illustrated Catalogue Vol. 263 sent on application

1125 Chestnut Street,

PHILADELPHIA



## WOOD CARVERS' TOOLS

THE GENUINE S. J. ADDIS. LONDON MAKE

Recognized by experts the world over to be the finest quality made

Send for Catalogue No. 2219, Entitled "Wood Carvers' Tools and Accessories"

**HAMMACHER, SCHLEMMER & CO.**

HARDWARE, TOOLS and SUPPLIES

NEW YORK, SINCE 1848

4th Ave. and 13th St.

## Artists' Materials of Rare Quality

Ever stop to consider the paramount importance of using dependable materials in the production of an oil painting? The very life of the painting depends upon it. Two things—canvas and oil colors—decide the fate of a painting. If they are of good quality it will last a century, and if they are unreliable the picture will crumble away in short order. We handle only the best of everything. These good qualities we sell as low as they can possibly be sold, but materials the only qualities of which are their low prices, we do not offer at any price.

Send for our big 300-page Artists' Material Catalogue

**Hirshberg Art Co., Dept. XX**

334 N. Howard Street, Baltimore, Md.



# Art Tuition

## THE TECHNICAL CLASSES

.. of the ..

### St. Louis School and Museum of Fine Arts

COMPETENTLY COVER THE FIELD

Drawing, Painting

Sculpture, Applied Art

THE ILLUSTRATION, POTTERY, BOOKBINDING  
COURSES

Are Pronouncedly Practical Successes

Grand Prize from International Jury

For Methods and Results in Art  
Education.—From St. Louis, Large  
Public and Private Gifts for  
Art Education in the West.

The City has voted one-fifth mill, or more than \$100,000 a  
year, for this institution.

Director, HALSEY C. IVES, LL.D.

Next Term Opens September 23

Write for Illustrated Handbook Free

## POPLAR STREET STUDIOS

Two suites yet to let. Delightful and convenient. Overlook-  
ing Brooklyn Bridge, river and lower New York. Address  
CAMERON MACHINE CO., 61 Poplar Street, Brooklyn, N. Y.

## ART ACADEMY

OF CINCINNATI

ENDOWED Complete Training in Art SCHOLARSHIPS

*Drawing, Painting, Modeling, Composition,  
Anatomy, Wood Carving, Decorative Design  
applied to porcelain, enamels, etc.*

FRANK DUWENECK	C. J. BARNHORN	HENRIETTA WILSON
V. NOWOTNY	WM. H. FRY	KATE R. MILLER
L. H. MEAKIN	ANNA RIIS	W. E. BRYAN

40th YEAR: SEPT. 23, 1907, to MAY 23, 1908 - - \$25.00  
J. H. GEST, Director, - - CINCINNATI, OHIO

## School of Industrial Art OF THE PENNSYLVANIA MUSEUM

BROAD AND PINE STREETS, PHILADELPHIA

Thorough work under trained specialists  
in all branches of Fine & Industrial Art

Special provision for classes in Illustration, Archi-  
tecture, Decorative Painting, and Sculpture,  
Pottery, Metal Work, Industrial Design, Textile  
Design and Manufacture.

L. W. MILLER, Principal

In writing to advertisers, please mention The International Studio.

# Art Tuition

## THE ALEXANDER ROBINSON SCHOOL

ESTABLISHED 1900

(Painting Tours in Belgium, Holland, Italy and Spain)

*(Intended mainly for those taking up Painting professionally)*

Methods from the sketch to the completed work as applied  
to Landscape, Street Scenes, Markets, Costume Figures,  
Interiors, etc.

Specialty: MODERN WATER-COLOR in all its branches;  
Oil, Pastel, Black and White, Composition  
(A feature of the School)

AUTUMN CLASS August to Nov. 1st **HOLLAND**

WINTER CLASS Jan. 1, 1908, to April **TUNIS (Algeriers)**

SPRING CLASS, 1908 April to July **VENICE**

Mr. ROBINSON is a yearly Exhibitor in many important  
shows (Salon Paris, etc.) His pictures are in permanent col-  
lections—Museum Ixelles, Bruxelles, Moscow; in many noted  
collections in America.

Member of The American Water-Color Society; New York Water-  
Color Club; Société Internationale Aquarellistes, Paris; Société  
Internationale Arts et Lettres, Paris; Royal Belgian Society;  
"Labour" Art Society, Brussels.

Subscriptions reasonable. Careful attention to Students  
Apply, permanent address, Letters to be forwarded, care of

THE ENGLISH BANK, .. .. BRUGES, BELGIUM

## TEACHING, MAKING, BUYING SUGGESTIONS and SHOPPING

For Home Decoration, Furnishing and Arrangement

Personal Instruction in Color, Design and Crafts

BIRDALINE BOWDOIN EVELYN MANLEY

Telephone, 3531 Bryant 516 FIFTH AVENUE, N. Y.

## Troy School of Arts and Crafts

TROY, N. Y.

EMILIE C. ADAMS, Director

Cast Drawing, Drawing and Painting from Costume Models.  
Illustration, Composition, Anatomy, Decorative Design, Oil and  
Water Color, Wood Carving, Metal Work, Leather Carving, Mod-  
eling, China Painting. For further information address

Miss EMILIE C. ADAMS, 853 Second Ave., Upper Troy, N. Y.

Private and Class Instruction in Drawing and Painting  
PORTRAITURE A SPECIALTY

Reasonable terms for Winter Course. Circular on application. Address

MISS ROSALIE PALMIÉ

Room 406 Broad Arcade 1947 BROADWAY, NEW YORK CITY

Will take a limited number of pupils for  
ILLUMINATION AND MISSAL PAINTING  
in my New York Studio—2 lessons a week  
—beginning in Oct., '07. Terms reasonable.

Address EMMA ISABEL SHEA

Post Office Box 35

Elizabeth, N. J.

AD. VIII

# Art Tuition

## ART SCHOOL

Awarded International Silver Medal at St. Louis, 1904

Term: October 1—June 1. For Beginners and Advanced Students.

Design, Modeling, Wood-carving,  
Cast and Life Drawing,  
Water-Color and Painting;  
Evening Class in Costume Drawing.

Instructors:

SOPHIA ANTOINETTE WALKER, HELEN M. TURNER

Young Women's Christian Association,

7 East 15th St., New York.

Office Hours: 9 A.M. to 5 P.M. and 7 to 9 P.M.

## WRITERS



We sell Stories, Poems, Jokes, Illustrations, Designs and all Publishable Material on Commission

If you can produce salable work we know who wants it and who will pay best prices for it. We can save you time and money in the disposal of your Productions by our careful system. Our plan is explained in our booklet "Cash Returns," sent to any address for four cents.

THE BURELL SYNDICATE, 770 Brunswick Bldg., N. Y. City



## ARTISTS

A THOROUGHLY MODERN

## School of Arts and Handicrafts

Finely Equipped Shops and Expert Instruction in METAL WORKING, BOOKBINDING, WOOD CARVING, MODELING, LEATHER WORKING, POTTERY.

Three Year Courses in Fine Art, Decorative Art, Normal Art, Architecture.

Four Free Scholarships Awarded Yearly. Cash Prizes. For illustrated circular, address

THEO. HANFORD POND, Supt.

Department of Applied and Fine Arts  
MECHANICS INSTITUTE, ROCHESTER, N. Y.

## THE MISSES MASON

Studio: 48 East 26th Street, New York

Classes in  
Design, Decoration of Porcelain  
Catalogue on Request

In writing to advertisers, please mention *The International Studio*.

# Art Tuition

## The New York School of Art

2237-2239 BROADWAY, Corner of 80th Street

WINTER TERM

September 9th, 1907, to June 1st, 1908

Comprehensive Courses in the  
Fine and Applied Arts

Daily Classes in Life, Portrait, Still Life, Illustration, Composition, Design, Interior Decoration and Normal Art. Diplomas and Certificates.

Among the Instructors are ROBERT HENRI, CLIFFORD CARLETON, DOUGLAS JOHN CONNAH, FRANK ALVAH PARSONS, LAWTON PARKER and KENNETH HAYES MILLER.

For particulars address

SUSAN F. BISSELL, Secretary

## New York School of Industrial Art

343 WEST 57TH ST: A PROFESSIONAL SCHOOL of DESIGN

Architecture, Interior Decoration; Textile, Costume & Commercial Design; Art Crafts. Teachers of these Subjects Thoroughly Trained.  
ELISA A. SARGENT, President.

## Los Angeles School of ART and DESIGN INC.

EST. 1887

Every branch in Drawing, Painting, Illustrating; under artist exhibitors in the chief galleries of Europe. Illustrated prospectus.  
L. E. G. MACLEOD, Director, Los Angeles, Cal.

## THE BENSON SCHOOL OF APPLIED DESIGN, NEW YORK

Individual instructions; designing for draperies, dress silks, wall papers, book covers, etc. Pupils' school work shown for sale.

POSITIONS SECURED FOR GRADUATES

Successfully taught  
at home by **CORRESPONDENCE**

Write for Illustrated Catalogue

321 West 94th Street, Near Riverside Drive

## MISS EMILIE C. ADAMS MINIATURES

Portraits and Figures on Porcelain and Ivory. Decorative Work in both Mineral Painting and Water Color.

Studios: 745 Third Ave., Lansingburgh, N. Y., and Director of the Troy School of Arts and Crafts, Troy, N. Y.

## The Art Institute ART SCHOOL of Chicago

W. M. R. French, Director N. H. Carpenter, Secretary

Study art under the most favorable conditions in this country—in the Art Institute with its art galleries, permanent collections, passing exhibitions, lecture courses, libraries, and constant association with accomplished artists and teachers.

Drawing, Painting, Illustrating, Normal Instruction, Sculpture, Decorative Design and Architecture. Students may enter at any time. No art student, east or west, ought to select his school until he has seen the fine illustrated catalogue of the Art Institute, mailed free on application.

Be careful of the name, the Art Institute.

RALPH HOLMES, Registrar

Dept. P., Art Institute

CHICAGO, ILL.

# WILLIAM J. LOCKE



## THE BELOVED VAGABOND *One of the Six Best Sellers*

"One of the most complete, convincing and entirely delightful characters that have made their debut between book covers for a long time."—NEW YORK TIMES.

## THE MORALS OF MARCUS ORDEYNE

"By far the best thing he has done."—DIAL.

AT THE GATE OF SAMARIA  
WHERE LOVE IS  
A STUDY IN SHADOWS  
THE DEMAGOGUE AND LADY PHAYRE

THE USURPER  
DERELICTS  
IDOLS  
THE WHITE DOVE

12mo. \$1.50 each.

## FOR THE WEEK-END

A LOVE STORY

By HANDASYDE, Author of "Four Gardens." 12mo. \$1.50

"Only a woman would write such deep and intimate truth about the heart of another woman."—LONDON STANDARD.

"A passionate story of love—and innocent love, too,—in the Smart Set."—LONDON SUNDAY TIMES.

"Has a distinct character of its own. Reading that is good and alive."—LONDON TRIBUNE.

"A genuine story of passion. Managed with considerable skill and a good deal of delicacy and pathos."—LONDON MAIL.

## THE WINGLESS VICTORY

"The London Literary Success"

By M. P. WILLCOCKS, Author of "Widdicombe." 12mo. \$1.50.

"The character (of the heroine) is portrayed with exceptional skill, as are the portraits of the husband and Joanna, the Magdalen. The latter-named is a triumph."—PHILADELPHIA PRESS.

"The strength of keen analysis, vivid descriptive power and a characterization of the rustic population of Devon and Dartmoor fairly comparable with the work of Mr. Phillips and other disciples of the school of Thomas Hardy."—DIAL.

"Rises high above the level of common day fiction. Invites a second reading with a still further examination of and lingering over certain choice passages."—NEW YORK EVENING POST.

## THE STRONGEST PLUME

By HUGH DE SELINCOURT. 12mo. \$1.50.

THIS is the story of a girl who gradually comes to see that she cannot be purified from a moment's mistake by a lifetime's marriage. She touches life at its very heart, and gains at last the courage from her experience of life and death to stand by herself without the props of convention, which help the weak as much as they bruise the strong. The title of the novel is taken from the novel's motto:

"The strongest plume in wisdom's pinion  
Is memory of past folly."

"Mr. de Selincourt deals with a problem quite worthy of serious consideration, frankly but restrainedly. Excellent studies of character."—LONDON DAILY NEWS.

**JOHN LANE CO., 110-114 West 32d Street, NEW YORK**

# ARTISTS' MATERIALS

## F.W. Devoe & Co.'s

### Artists' Tube Colors

CANVAS, ACADEMY BOARDS,  
FINE BRUSHES FOR OIL AND  
WATER-COLOR PAINTING, etc.

"THE STANDARD QUALITY"

*Everything in Artists' Materials*

## F.W. DEVOE & C.T. RAYNOLDS CO.

Fulton Street, cor. William NEW YORK 176 Randolph Street CHICAGO

The Largest Manufacturers and Importers of Artists' Materials in the United States

## WM. H. POWELL

Fine Art Gallery, 983 6th Ave., New York

### ARTISTS' MATERIALS

New York Agent for LEFEBVRE-FOINET and  
EDOUARD of Paris

And BLOCKX'S HAND-GROUND, PERMANENT BELGIAN OIL COLORS and AMBER VARNISH, BEST IN THE WORLD, French Canvas and Brushes. Mail Orders have prompt attention.

PICTURE FRAMING A SPECIALTY

A WONDERFUL INVENTION!

## ALGUMAR WATER COLORS

BLEND LIKE OIL. DO NOT RUN

Picture upright. No waiting for washes to dry. Full instructions free.

A. G. Marshall, Thousand Island Park, N. Y.

## PYROPEN

Leading Instrument in Pyrography. Heated by GAS. No Benzine or Bellows. All Art Material Dealers; or post-paid for \$1.00 from WISEMAN MFG. CO., 147 W. 26th Street, New York

In writing to advertisers, please mention *The International Studio*.

## A. Sartorius & Co.

Manufacturers and Importers of

### Artists' Colors and Materials

#### China Colors in Powder

(In vials or in bulk.) Vials and corks for dealers and teachers bottling china colors.

#### China Colors in Tubes

(Oil and Water Preparation.)

#### Artists' Oil Colors, Artists' Water Colors, Artists' Moist Oleo Colors, Artists' Fine Brushes

Write for A. Sartorius & Co.'s Catalogue containing many instructions how to mix and apply colors.

45 Murray Street, New York

For a smooth writing, easy working pen—use the Spencerian Steel Pen

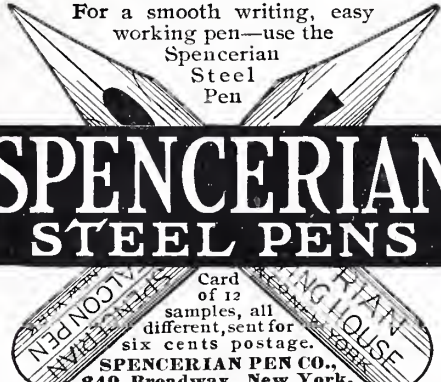

**SPENCERIAN STEEL PENS**

Card of 12 samples, all different, sent for six cents postage.  
SPENCERIAN PEN CO.,  
349 Broadway, New York.

## DRAWING PENCIL PERFECTION

IN ELEVEN GRADES OF HARDNESS

Send 16 cents for generous samples of Dixon's American Graphite Artists' Pencils

JOSEPH DIXON CRUCIBLE CO., Jersey City, N. J.

AD. XI

**THE  
MAULEVERER  
MURDERS**



**A DETECTIVE STORY BY  
A.C. FOX-DAVIES**

**JOHN LANE COMPANY, 110-114 W. 32d St. New York**

*By the Same Author*

**THE DANGERVILLE  
INHERITANCE**

*"A detective story of which Gaboriau might be proud."*—LONDON POST

**12mo. \$1.50**

*"Of the Wilkie Collins order."*—NEW YORK TIMES

*"Plenty of excitement."*—DETROIT NEWS-TRIBUNE





*Copyright 1903 by Photographische Gesellschaft  
By permission of the Berlin Photographic Company, New York*

WANDERING THOUGHTS  
BY F. D. MILLET



# The INTERNATIONAL STUDIO

VOL. XXXII. No. 128

Copyright, 1907, by John Lane Company

OCTOBER, 1907

## THE DOMESTIC PICTURES OF FRANK D. MILLET BY CHARLES M. SKINNER

WHEN I say that the thing I best like in the figure paintings of Frank D. Millet is his precision, I realize that I inflict a shock on some readers. What! Precision in art? Why, that is geometric, photographic! So it is; that is, one kind of precision, to which objection is right enough. But there is another which implies grasp of theme, certainty of technic, even conscience, and that is what I would signify in the case of Mr. Millet.

It is often interesting to imagine what manner of man a painter would be if he had been born a

dozen years earlier or later; hence, under different conditions and influences. The composer who was born before Wagner had reason to lament his haste, for Wagner was to make his music well nigh obsolete; so the artist who just preceded the impressionist movement often finds himself reproved for tightness of drawing, hardness of lighting, dryness of color, mechanism in his composition, just as the impressionist is liable to find himself abused in fifty years for slovenly handling, falsity of tone, jumbled grouping and inability to see nature. Mr. Millet chose a very good season, on the whole, in which to make his entry into life and art, for he avoided certain methods and personalities, both among the patriarchs and "the



Copyright, 1900, by F. D. Millet

HOW THE GOSSIP GREW

BY F. D. MILLET

CXI

## The Domestic Pictures of Frank D. Millet



Copyright, 1900, by F. D. Millet

OFF DUTY

BY F. D. MILLET

young fellows," that have generally, yet not always, beneficially affected American painting. What manner of artist would he have been, I wonder, had he been persuaded into impressionism. I question if he had become an artist at all, in that case, for it seems as if what is essentially and individually his art is opposed to it in method and spirit. When I refer to his exactitude, however, I do not refer of necessity to his precision in line, in lighting, and so on, but to the expression of his thought and vision. Corot and Pissarro may be as exact as Meyer Von Bremen and Meissonier, when it comes to that.

Mr. Millet's art, then, has that certainty which comes not merely of practice in its mechanics, but of a balanced temperament, of calm seeing, of a healthy man's pleasure in color, fluency of line and harmonious grouping. Yet while his work has forthright quality, as expression, it has the charm of suavity and brightness as story. And if it is laid up against him that he is a subject painter, let it be noted that in no instance does subject interest transcend pictorial interest, and so long as a picture is satisfying esthetically, its literary significance, if it has any, may add to it, but can not detract. When we hear the *waldweben* in "Siegfried" or the prelude to the "Rheingold," we listen for the music's sake. That a subject interest is added, and that the sounds signify the tossing of trees and murmur of the river, makes the music

only the more enchanting, for the theme is worthy of the music. So long as we enjoy Mr. Millet's work we can enjoy the story it tells or overlook it, as we please.

As a painter of *genre* Mr. Millet outranks Mr. Stone, Mr. Orchardson and sundry others who may suggest him, because he is frugal of sentiment; or, rather, he never lapses into sentimentality. The dangerous gift of humor

he also holds in abeyance, and wisely, for nothing else so quickly turns an artist into an illustrator. It might be supposed, likewise, that his experiences as special artist at the front, in a war or two, might have sensationalized his themes, but such is not the case; their dominant note is tranquillity, a sane and delightful attribute, appreciated in these days of restlessness; and he has found his *metier* in those domestic scenes, preferably of the old country, in which agreeable people are seen amid agreeable surroundings.

In his pictures of episode he reveals the situation, not by acting, but by suggesting it; therefore they have the charm of repose; but this pertinence is not obtained at any cost of vitality: his people are all animate; they have character, and, when he would rule it so, distinction. Were I a painter of animals or the human figure I would pose my models in such manner that if they were suddenly spelled into the slumber that held the land while the Sleeping Princess waited for the Prince, they would retain a measure of that pose. Horses at a gallop, cows tossing their heads and tails, men striding, thrashing their arms, fighting, women at the scrubbing-board, children dancing—these are hard matters to put into sculpture and pictures. If you are to live with them it will not be a month before you would beg them to be quiet. I would not care to live with Laocoon. Effects of animation are entirely possible without forcing the action into



Copyright, 1904, by Photographische Gesellschaft  
By permission of The Berlin Photographic Company, New York

THE BLACK SHEEP  
BY F. D. MILLET

## The Domestic Pictures of Frank D. Millet

drama. In the well-known *Romans of the Decadence* Couture gives all the effect of revel, yet examination reveals not a single figure in an uneasy aspect or position.

Mr. Millet's canvases, then, have incipient or completed action—rarely the suspended motion that tires us by its arrest or vehemence. The gospel of the strenuous life may apply itself to the painting of pictures, but the powers forbid that they should represent the strenuous life, save as we find it depicted in such places as the Versailles gallery of battles!

This delicious peace that soothes and woos us in Mr. Millet's work is more than a matter of pose, to be sure. It is a totality of impression resulting from a pleasant craft in its pictorial elements. It is

in the atmosphere and environing, no less than in the people. In those immaculate breakfast-rooms of the early Victorian era you almost hear the clock tick, and you know that the jar of the world enters only as a rumor. The gossips over their tea might have stepped out of Jane Austen's or Mrs. Gaskell's novels, but they are concerned with nothing deeper than social excitements. A certain breeding denotes itself in the high grooming of the apartments; in their very furniture: the claw-foot tables, the Chippendale and Sheraton chairs, the bureaux and dressers with their fine old plate, the minifying mirrors, the candelabra, the Delft on the mantel, the bowls of flowers, the formal pictures on the walls. There may be a fox-hunting squire somewhere about the place, but we can be sure that he will moderate his Dammes and even the rubor of his countenance in these surroundings.

As an instance of Mr. Millet's method, observe his *The Love Letter*. The scene is one of those clean, quiet, softly lighted rooms that are pervaded with a sense of ancient ownership and consequence—a sense emphasized by the portrait group above the desk: easily a Lely. The white walls, the waxed floor and its rug, the rich mahogany with its refined and simple lines, the shining glass and silver, the screen before the fire, the snowy majery, are his setting, and in it he has placed only two figures: the father, a neat, precise, conservative old gentleman, who, having examined his morning mail, is scanning his newspaper and absently stirring his tea; and his daughter, slender, fine and innocent, in a fresh gown and apron, who stands hesitant and meditant before the table, holding a letter



Copyright, 1900, by F. D. Millet

FIRESIDE COMPANIONS

BY F. D. MILLET



*Copyright, 1900, by F. D. Millet*

**ROOK AND PIGEON**  
BY F. D. MILLET

## The Domestic Pictures of Frank D. Millet

in which we are sure there is matter of consequence. An affair of the heart is obviously touched upon here, yet it is suggested: not related. Imagination is piqued, may be, for a solution of the little mystery, but how much better as a picture this is than a solution: parental rage, scorn or sorrow, filial tears and protestations; or, the engaging but trite sequence of smiles and orange blossoms! Nothing grandiose in this, but it is a human document.

Tranquillity is felt in the picture of the young woman at the piano, idly running over a piece of music; and notice here the painter's knack in textures: the shining folds of the gown, the wool of the tapestry, the grain of the wood, the light, loose petals of the flowers, the glimmer of the glass. Here, too, is dangerous matter, since it is easily possible for a painter's skill to run away with him when he undertakes surfaces, and to fall into mere imitation. As a rule, the more of surface, the less of depth. A picture is not an imitation of an object: it is a disclosure of the painter's understanding of that object. If it is an imitation, it pretends to be what it is not, and great art never does that, whether it be an art of painting, or of acting, or of architecture, or of music. A picture is wrong,

as a picture, if its components deceive us, or if they come out of the frame to obtrude on our notice. But in this instance they keep their place as part of a realistic portrait treatment, none the less veracious because of its grace; indeed, we should feel the lack of these minor truths in an otherwise highly finished work.

This picture seems to defy certain customs in composition in that its darks are not unified, yet there is no effect of spottiness; there is, in fact, a subtle relation of the heavier masses, the chair arm and the vine about the mirror serving as their connections. Here, as in his other works, there is economy of the painter's material; a realizing of the possibility of turgidness that inheres in crowded canvases, while his simplicity never goes so far as thinness, and in the development of his theme the author is but permissibly academic.

As an instance of scholastic use the *Rook and Pigeon* is worthy of study. Note the reduction of the group to its lowest terms by keeping the darks together, yet note, also, how the lights gain brilliancy and relief from the dark, the young man's light costume showing in front of the cavernous fireplace, while the darks gain strength by contrast with the light, the figure in the hat



Copyright, 1900, by F. D. Millet

LUCKY AT CARDS, UNLUCKY IN LOVE

BY F. D. MILLET



Copyright, 1900, by F. D. Millet

BETWEEN TWO FIRES  
BY F. D. MILLET

being posed against the window. There is a quietly humorous symbolism in this performance, also, the innocence of the lamb and wickedness of the wolf being denoted in this very contrast of light and shadow. The model for the young man who is being fleeced at cards is hardly so ingenuous as might be; he is old enough and has been at school long enough to know better; but his *vis-a-vis* is a joy: a Robert Macaire, a scamp who, thinking he

has some likeness to a gentleman, leads a few of the impressionable to share that faith long enough to be "done" at his hands. The rogue has the habit of watchfulness, he "bluffs" coolly, his face is roughened with wind and wine, and though he seems at his ease it is imaginable that he lives in the fear of sheriffs.

Yet perhaps we could abide with this fellow on easier terms than with certain of Mr. Millet's Puritans. There is such a thing as being too good, or, at least, being too well convinced of it, and a vinegar-faced angel will not so easily win converts for the kingdom if the devil is in good humor. That stern and solemn functionary in *The Black Sheep*, who is lessening a recalcitrant damsel, possibly for the worldliness revealed in her florid raiment, would be an easy man not to live with in this year of grace. The artist has made this obvious in his uncompromising look and bearing; he bends nowhere, save at the elbows, and you wonder if they creak; his dress is as severe as his countenance, conscious virtue pertains to his collar and shoes, while his hat is a pillar of righteousness. It would have been easy to make this picture whimsical or farcical—a grimace on the face of the suffering girl, a frown on the brow of the preacher, a look of alarm in the eyes of the spectators, would have



Copyright, 1900, by F. D. Millet

OLD MELODIES

BY F. D. MILLET

disturbed the balance and tokened artifice; but the artist has played the observer, merely, and set down no more than might have happened.

He has allowed a little more latitude to the spirit of satire in *Between Two Fires*, where an equally solemn Roundhead, sitting at meat, endures the chaff of a pair of buxom wenches who might perturb his resolutions with more than their wit. Do we detect in that protesting eye a twinkle of willingness for the ordeal? Is there a faint puckering of the mouth that presages an eventual collapse of the sacred reserve, and the forbidden exercise of a smile? Can our Saint Anthony feel a warm tickling at the bottom of his heart, as he gazes into the pert faces and harks to the jests and laughter?

If all this is insufficiently serious, we may turn to the study of characters in church, or to the sweet disclosures of motherhood and domestic life that Mr. Millet has made in his recent works. True, he gives us no epics; he pleases us more by his deft drawing, pleasant color and amiability of subject than by splendor of imagination or sweep of execution; he moves us with none of the great passions; he is not a preacher or psychologist, offering problems to himself and us; he has founded no school, holds no revolutionary theories, respects the conventions, displays a nice gallantry toward





Copyright, 1893, by Photographische Gesellschaft  
By permission of The Berlin Photo-graphic Company, New York

THE LOVE LETTER  
BY F. D. MILLET

the sex in the way he paints it, and chooses to live in "the teacup times of cap and hood," and the cheery days of Cowley and Herrick, rather than in a season when great cities poison the air for millions, and great worldly successes poison content in the unsuccessful more. In the presence of his pictures we are not stirred or lifted, but we find them genial, wholesome, and are pacified.

**P**RACTICAL BOOKBINDING—I.  
BY MORRIS LEE KING

BOOKBINDING in early times was carried on, for the most part (as were so many other useful industries), in connection with the religious orders. The monasteries were the chief centers for fine work in the way of illumination, hand-printed books and bindings of various kinds. The first good bindings of which I can find record came to Europe from the Levant—that is, from Arabia or Persia, gradually filtering through to Constantinople, to Italy, and so on, to France and Europe in general.

Before the art of printing was invented, however, bookbinding could scarcely be spoken of as having been widely known, because the only books then in use were printed with the pen, and copies were very scarce; they were to be found only in the possession of the monasteries and the very wealthy people of the time.

With the introduction of printing, however, binding became quite common, and early in the Middle Ages it developed into a fine art. The binders of those days, while they had more talent in the way of making designs appropriate to the text, did the technical work very crudely, the tools being made by the binders themselves, in many cases. This resulted in the "finishing" being done in what to-day would be considered a very haphazard and careless manner. At the same time these bindings still exist, and in many well preserved examples the condition of the finishing shows that it was not only solidly done, but that exceedingly good materials were used. While the modern binder is far ahead of his predecessor as regards precision and beauty of finish, he has the very serious defect of a lack of ideas in the way of new designs.

NOTE.—This article is written principally for those who are interested in an amateur way in this subject or are contemplating taking it up, and at the same time are not able to come in contact with teachers of the art and others interested in it. I have not endeavored to cover the whole field, nor to go into the different methods in use in different countries. I have, however, endeavored to describe the processes through which a book passes from the moment the original casing is removed until it lies before us, well tooled, a thing of beauty.

It was Grolier, of Lyons, who first developed a special style of designs individual to himself. Many examples of his work are still extant, and his name is perpetuated by many societies of the present day. Since his day, binders of great repute have been more or less numerous, and various styles of bindings have been originated and are known by the names of such men as Le Gascon, Derome, the Brothers Eve, Jansen, Padeloup in France and Roger Payne in England.

During this formative period, leather was not as universally used as it is to-day, many bindings being made of wood, silver, velvet, cloth of gold and embroideries on various materials.

Of the modern French school, we need only mention a few names, such as Trautz, Chambolle-Duru, Gruel, Lortic, Marius-Michel, Ruban, and in England, Bedford, Zaehnsdorf, Riviere and Cobden-Sanderson. Aside from those mentioned, there are of course hosts of others, some of equal repute, as well as many who hope to achieve fame.

As the term "bookbinding" covers a variety of work, it is impossible in an article of this nature to treat it in all its varieties; so that it should be understood that the only kind of binding that will be here referred to is that known as "extra first-class work," and no attempt will be made to explain in detail the methods used in cheaper grades of work. Many of the processes described, however, may be used to advantage in simpler work; the extra expense involved, both as regards quality of material as well as extra cost of labor (owing to the time devoted to the work itself), is, however, prohibitive for ordinary commercial work.

Much of the work of the present day is well executed, as far as the technique is concerned, but many of the designs are imitations of the older and well-known styles or inferior innovations. In many cases the books are overdecorated, owing to a desire to have a showy piece of work, this causing a loss of richness and dignity, due in many cases to over-decoration alone. By studying the work of the best binders of the 15th, 16th and 17th centuries, one gets much information, and by constant endeavor may finally acquire a style of one's own.

During the last few years we have seen in our country, in connection with bookbinding, the development of a new class of art workers, who may be classified under the general term of amateurs. This term, however, does not accurately cover all the persons who are thus classified. Of course, the real amateur is supposed to be a binder who is working for pleasure and not for profit. There

## Practical Bookbinding

are comparatively few of these, however, for many so-called amateurs are really semiprofessionals, engaged more or less in the production of bindings for profit. This applies both to teachers and those who are not engaged in teaching.

The net result, however, of the growth of interest in this country has been to develop a certain number of binders who do work of the first class. This, taken in connection with the professional binders who do commercial work entirely, renders it unnecessary nowadays for the lover of good books to send them abroad to be bound. While the best work in this country equals that done abroad, there are comparatively few binders who are capable of producing work that measures up to the standard of the best foreign binders. Aside from the scarcity of first-class workers, we must consider the question of cost; and as labor of all kinds is better paid in this country, it follows that binders here cannot, as a matter of fact, compete in price with those abroad, and it may be that this is one of the reasons why so much work is still sent to foreign countries.

The amateur who begins work with a view to becoming a *good* binder should in every possible way cultivate a liking not only for the special work he undertakes, but also for allied lines of art, and will do well to observe the following maxims:

1st. Learn to *care* for *really* well-bound books by familiarizing one's self with such bindings and with fine editions of good literature, worthy of fine bindings.

2d. To make careful study of the details of mechanism, beauty and adaptation of fine binding; and also to gain accurate knowledge of the discrepancies and dangers that beset inferior work.

3d. To make perfection the goal of every effort. To do one's absolute best with every stroke of work, from least to greatest, and to condone no failures save through renewed knowledge, ability and effort to do better.

The simplest text-books for a beginner are:

"Bookbinding," by J. W. Zaehnsdorff.

"Bookbinding for Amateurs," by W. J. E. Crane.

"Bookbinding and the Care of Books," by Douglas Cockerell.

Brander Matthews's delightful "Bookbindings, Old and New," may be consulted with pleasure and profit. While not a technical handbook, it gives one a brief view of the history and styles of the art.

These are inexpensive and may be had through any bookstore.

One of the first questions asked by the seeker

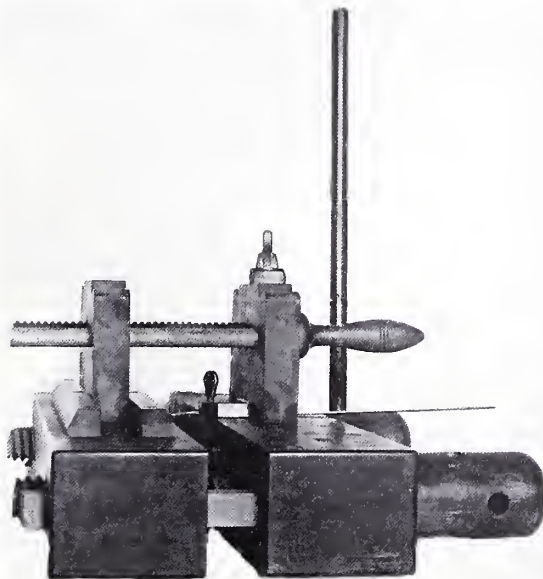

PLOUGH AND PRESS

after knowledge along this line is, What constitutes the difference between a well-bound book and the ordinary book of commerce? It is surprising how small the percentage is of persons who have any definite knowledge as to what the elements of a good binding are. Knowledge on this subject has spread very slightly, and only among a very limited class of people; so it is always necessary to explain carefully to the inquirer just what makes this difference.

The binding of a book is described in the two technical terms, "forwarding" and "finishing."

"Forwarding" covers collating, cleaning, sewing, backing, head-banding, putting on the leather—everything, in fact, that prepares the book for decorating and lettering.

"Finishing" comprises the designing of cover decoration, tooling of sides and back, as well as whatever decoration is done on the inside of the cover.

The ordinary book of commerce, which is generally sold in boards with a cloth or paper cover, is really not bound at all. The book is sewn by machinery, and the cover, which is technically known as a casing, is also made by machinery—in many cases being applied by the same machine. The connection between this so-called "cover" and the book itself is of the very slightest nature. The tapes or cords on which the book is sewn are held to the cover simply by one thickness of paper, and

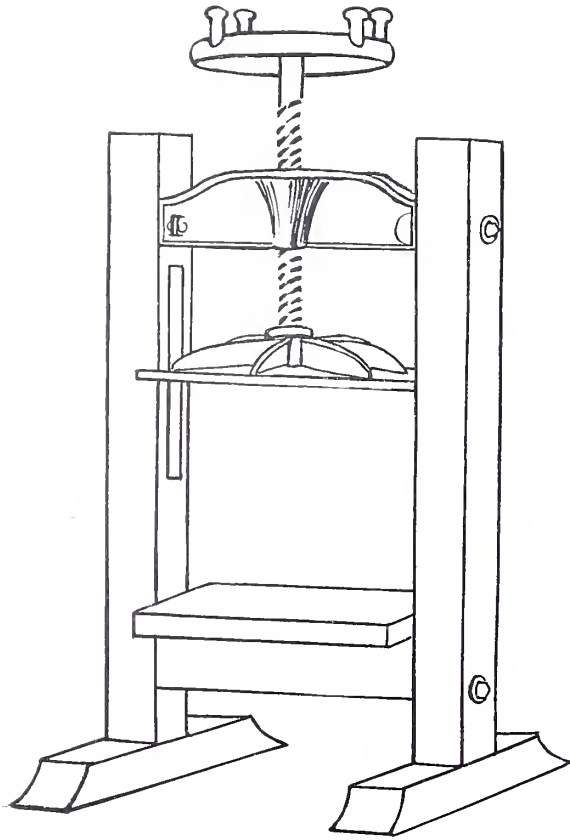

ENGLISH STANDING PRESS (WOOD)

in some instances by one thickness of "crinoline." The book is not strongly sewn, and it has no head-bands, save in some instances a strip of material (manufactured by the yard) pasted on in lieu of the head-bands, this being an imitation of the real thing.

A well-bound book, on the other hand, is properly sewn with linen or silk on linen cords; these cords are laced into each board in so firm a manner that it is impossible to remove the board without cutting the cord or tearing the boards to pieces. The head-bands are then worked on the book itself, these being made of a strip of vellum standing on edge and entirely covered with silk thread, each head-band being fastened to the book in from three to five places, thus becoming an integral part of the book itself when it is finished. The boards are then covered either entirely or in part with leather, which is a further strong connection between the cover and the book proper. The leather may either constitute a half, a three-quarters or a full binding. The book is then properly decorated either with a simple title or with whatever elaboration or decoration is desired.

While it is a very simple matter to enumerate the different steps through which a book passes, each step must be carried out very carefully and accurately, else the result will be other than first class.

From the time a book is given to a binder to be put in full leather until it is completed, two months or more may elapse; depending entirely upon how much tooling is done. It is necessary that plenty of time be given the binder, in order that one process may not be too quickly followed by another. *Good forwarding is absolutely necessary for good finishing.* Each process should be carefully carried out, as one depends upon the other, and a serious defect in one step throws the volume out of the first class, even though the other steps be well done.

*Training of binders:* In continental countries the apprenticeship system which is in vogue in all arts and crafts results in producing forwarders and finishers who have grown up in the business, so to speak. They usually begin as errand boys, in a shop, at ages from twelve years up, so that by the time they become full-fledged workmen they have spent from ten to fifteen years in becoming thoroughly familiar with every process and method in vogue at the time. They also go through a period of three or four years' careful instruction, both in the shop and in technical schools, acquiring not only a technical knowledge of their own particular craft, but being instructed also in knowledge most essential to any accomplished artisan, such as the elements of design of all kinds, instruction in the historical characteristics of each particular period, and other points of a similar nature. One sees, therefore, that the making of an accomplished workman under this system is not a matter of picking up a new occupation in the course of a few months; on the contrary, he chooses bookbinding as his life work and really grows up in its atmosphere.

With us it is somewhat different; we have not yet reached the point where a young man selects an occupation or where it is selected for him in early youth, and he serves in it as an apprentice; on the other hand, change seems to be inherent in the American atmosphere. This applies to occupations of all kinds. In foreign countries a man almost never changes his occupation, and in many instances follows his father's occupation as a matter of course. Here we see about us constant change of occupation, even after a man has spent years of his life in fitting himself for a certain line. This naturally results in less careful work in all branches of art and trade, and to a generally unsettled industrial condition. No apprenticeship system is in vogue here except

## Practical Bookbinding

to a very limited extent, so that we constantly see men and women following an occupation which they have picked up on the spur of the moment, with more or less success.

We have, however, a number of professional binders in this country, and these should be divided into two well-defined classes: those who earn their living by forwarding and finishing in establishments where they are employed year after year, and those who may be called semiprofessional—who work more or less steadily at binding, earning part or perhaps the whole of their living thus, but who cannot be properly classified in the same category as regards skill with the professional workmen. In both classes, however, we have some exceedingly good workers, but I notice that the best of them are those who are foreign born and have therefore gone through a thorough course of training, or are, perhaps, men and women who have been able to spend years working by themselves or abroad, and have thus acquired great skill.

There is another large class, however, who have taken up binding more as a matter of interest and pleasure. In this class, also, there are some who have done exceedingly good work, but the great majority are less competent. Let us hope that the day will arrive when we will be able to include many of them in one of the other classes.

Up to about fifty years ago good binding was hardly known in the United States, but with the spread of wealth and especially of the traveling habit—which Americans have developed to such a great extent—knowledge on this subject has been acquired and spread about. This has resulted in the formation of many societies whose members are interested in fine books and, as a corollary, good binding.

The greatest cause, however, of the widespread interest which exists to-day has been the formation of various arts and crafts societies in all parts of this country. The older ones have, in many instances, become a great power for the spread of art knowledge of all kinds, including that of bookbinding. Many of them have special schools where binding is taught. There are a number of leading publishing houses also which have departments devoted to the production of fine editions, both as regards printing and binding. Several of them have even established special departments in their commercial binderies for the purpose of producing extra-fine work. One house in particular which I have in mind, has gone to the expense of sending a student abroad for a number of years in order that he might qualify himself by instruction under the

best foreign binders for the position of Director of Fine Bindings in that establishment.

The Grolier Club of New York, noted for its production of finely printed books, also extended its usefulness, by establishing a special bindery under the name of the "Club Bindery." This bindery, however, being solely under the control of the club, is not open to the public, as all work done there must be done for, or through one of the members. This bindery is noted for the production of uniformly beautiful work, which I believe is due, to a great extent, to the fact that the personnel comes almost entirely from France and England, where they had years of training in the best binderies.

*General considerations:* I have known of a number of instances where attempts have been made to begin bookbinding with incomplete or very unsatisfactory appliances. It is not possible to do first-class work with poor materials or with an incomplete outfit, though expert workers can get along and do good work with fewer appliances than the beginner. It should therefore never be attempted. It is not only unsatisfactory from the point of view of practice, but it is very discouraging to the beginner to find the best attempts result in

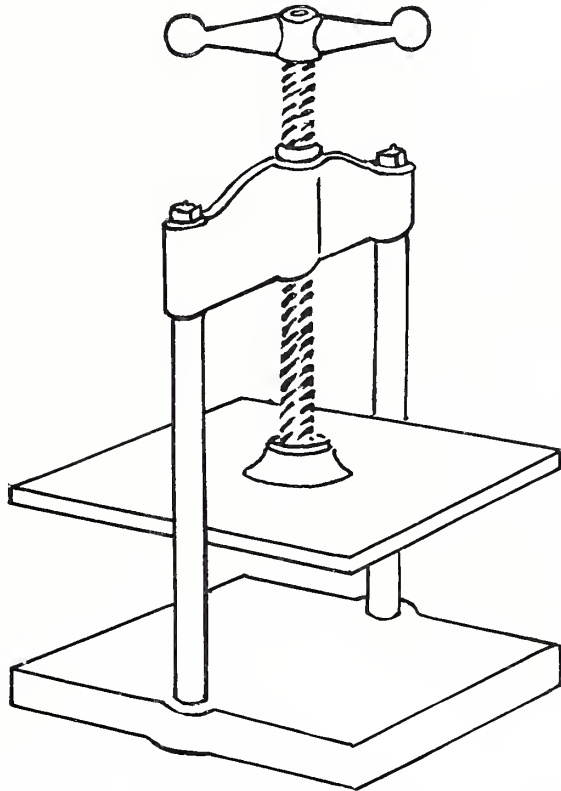

METAL PRESS (SMALL SIZE)

## Practical Bookbinding

KNIFE POINT FOR  
CUTTING BOARDS



would seem unnecessary to give advice of this kind, but, as a matter of fact, I have known of a number of instances where intelligent people have begun to work under these conditions and have as a result become discouraged unnecessarily.

*Space needed:* Living in a crowded city as I do, and seeing a good deal of work done by others where space is valuable, I have of necessity devoted considerable thought to economy of space. While this is not a matter of importance to all, still I think a majority of amateurs are obliged to consider the question. We are not all fortunate enough to have a special workshop. All the work that I have done has been accomplished on two tables or benches, four feet long by two feet wide, fixed in front of two windows. Three feet is a convenient height, but this depends upon the height of the worker.

One table is devoted to forwarding, and has

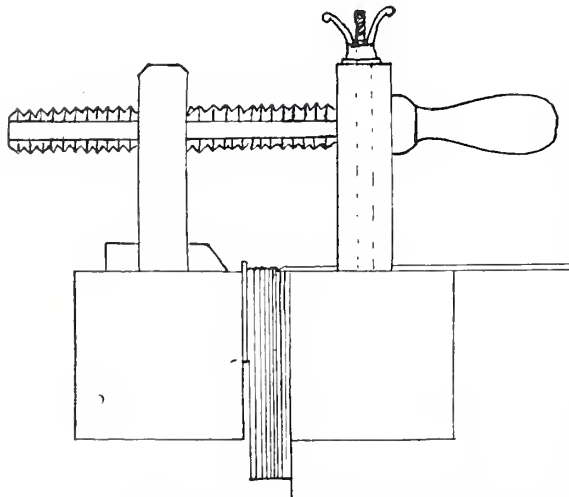

SECTION OF PLOUGH AND PRESS  
BOOK AND KNIFE IN POSITION

poor work—sometimes not due to any lack of ability or effort, but simply to lack of conveniences. It is better to become familiar gradually with what is and what is not needed, to accumulate tools slowly, but not to begin definite work until a somewhat complete outfit is at hand, and one has acquired by study of works on bookbinding, and by conversation with practical workers, some idea as to ways and methods. It

under it shelves and racks for holding pressing-boards, paring stones and the miscellaneous paraphernalia needed. The edge next the window has a raised ledge of six or eight inches, on which are arranged knives, straight-edges, etc. The other table, used mainly for finishing, holds the gas stove, etc. Above it on a side wall a small set of shelves gives room for the various small items needed in this branch of the work. This table has a number of drawers for

storage of papers, leathers, gold cushions, etc.

The raised back edge of the forwarding table, with an adjustable support on the front edge, holds the cutting-press when in use. This is not convenient, however. When possible, the usual "tub" should be on hand for daily use.

The press, be it the usual standing-press or a strong letter-press, must stand on the floor or on a separate block. Almost all the processes of binding may be carried on by artificial light, but in this case it is well to have two lights, so as to avoid strong shadows. I advise strongly, however, against using finishing tools under artificial light. It can be done, but it is difficult and not satisfactory even for an expert worker.

*Tools and necessary appliances:* The most important thing is the cutting-press and plough. The standard size made for use in commercial work of all sizes, is too heavy and clumsy to be used by a beginner. A smaller size is made and may be ordered through the regular dealers. It is much lighter and is easily handled and answers all purposes, as it takes books up to sixteen inches in length. The price is the same as for the standard size. As it is always made to order, it takes a few weeks to get it.

The standing-press may be of wood or steel and ranges in price from twenty dollars up. An amateur may, however, get along very well with a strong letter-press. I know of a number of amateurs in New York who are doing good work and who use only a letter-press. Another amateur living in the suburbs has converted to her use a small press formerly used in a cider mill.

*Finishing press:* A press of this variety, 14 to

KNIFE POINT FOR  
CUTTING SECTIONS.

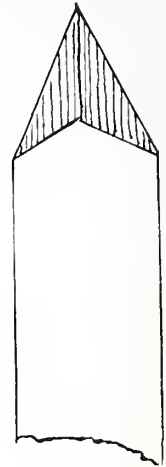

Practical Bookbinding

DETAIL OF.

LATEST AND BEST METHOD OF FASTENING THE KNIFE IN THE PLOUGH. STEEL PLATE WITH SLOT INTO WHICH THE THIN KNIFE SLIPS, HELD FIRMLY BY SCREW A. THE PLATE IS ITSELF HELD IN PLACE BY BOLT B.

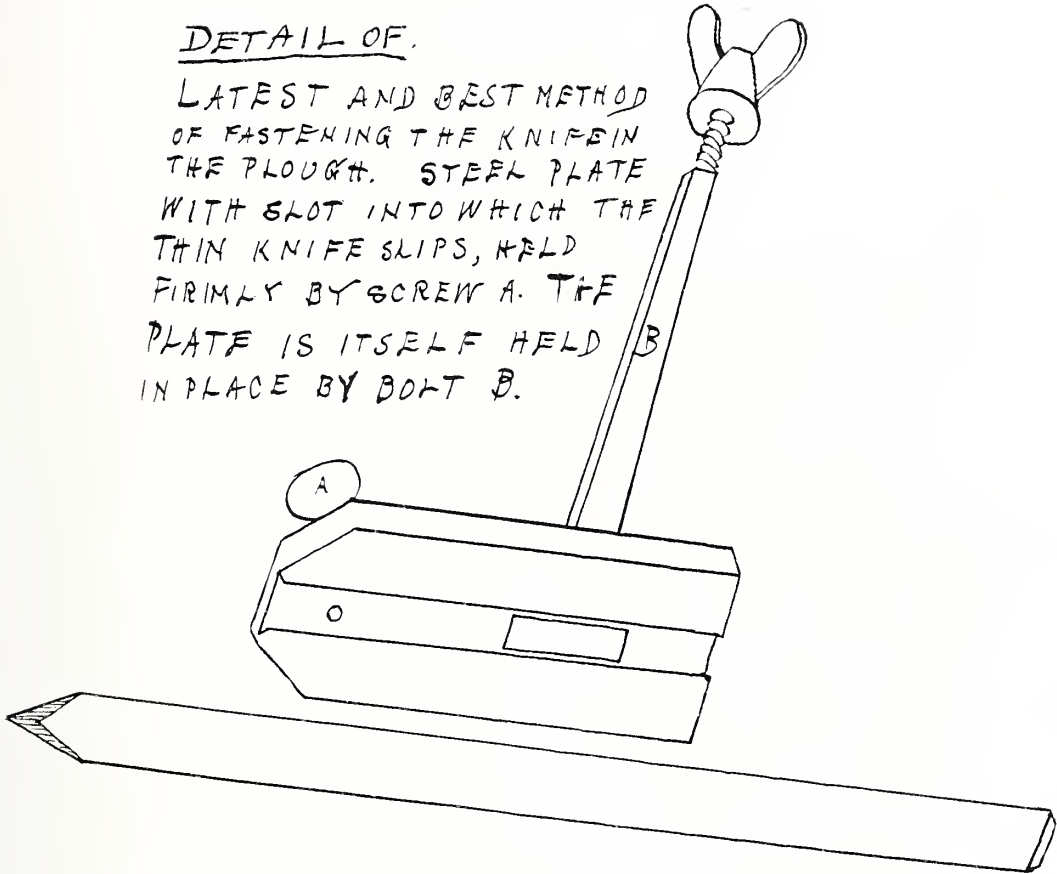

16 inches between the screws, is ample for the beginner. It should be lined with skiver\* on the inside and on the upper surface. This is convenient in many ways, especially when small books are being handled.

Knives of various kinds are needed as follows:

*Paring knives:* Two at least are needed—the one most useful is shaped as shown in the illustration (a); another shown at (b) is known as the French style, and is very useful in paring out backs and also for finishing the paring of edges; it renders them more even.

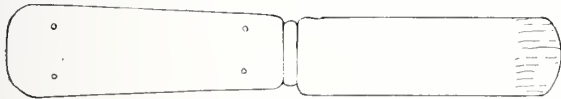

(B) FRENCH KNIFE

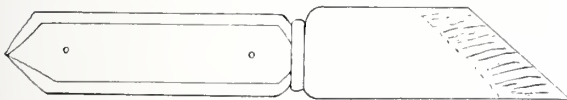

(A) PARING KNIFE

One knife, to be kept only for the cutting of paper, of the shape indicated herewith, should be in the knife rack. Only the rounded edge should be sharp.

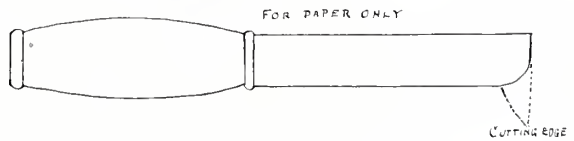

One or two knives with blades of this shape should be provided, also, for miscellaneous use.

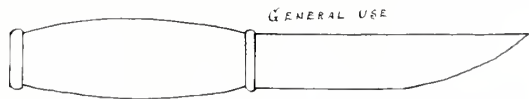

*Whetstones:* All cutting apparatus should be kept in good condition, as a torn edge of an end paper, a section, a piece of leather, caused by a dull knife, may result in hours of irritating repair work, and even then be unsatisfactory. One good oilstone and an ordinary whetstone (to be used with water or dry), a strip of sole leather, 2 or 2½ by 14 inches,

\*Skiver is the inner or flesh surface of the skin which is left when leather is "split." It is very useful for many purposes and can be had for a trifle

## Practical Bookbinding

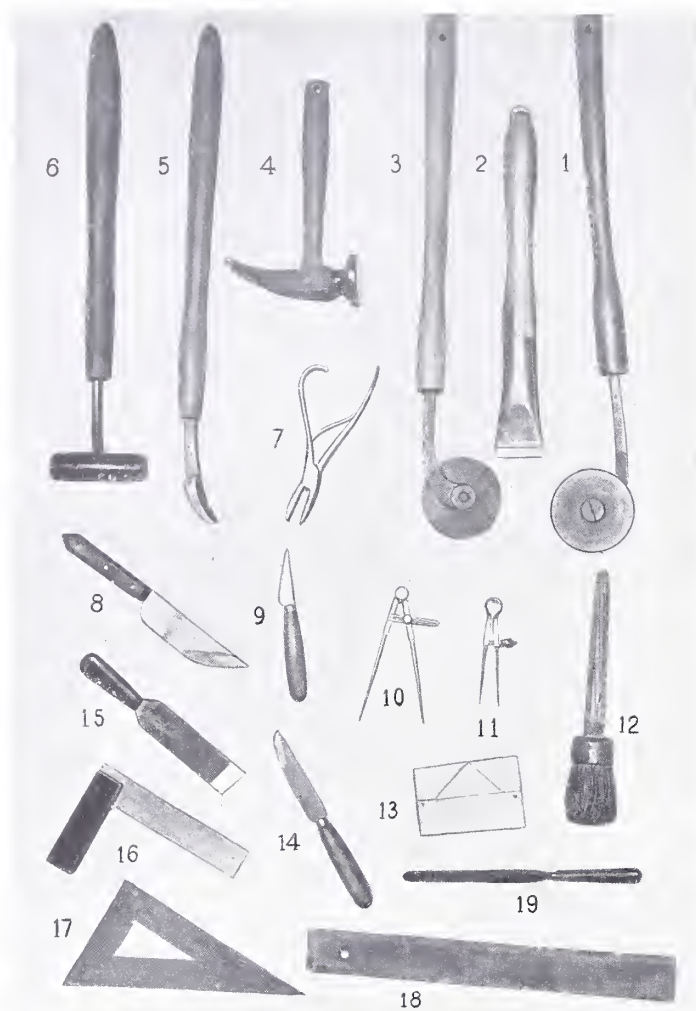

TOOLS: 1 and 3, Fillets; 2, Agate Burnisher; 4, Hammer; 5 and 6, Metal Burnishers; 7, Band Nippers; 8 and 15, Paring Knives; 9 and 14, Paper Knives; 10 and 11, Compasses; 12, Paste Brush; 17 and 18, Drawing Tools; 10, Gold Knife; 13, Pattern for cutting corners of leather in covering,

coated with oil and fine emery powder, are necessary. The latter, laid on the table when paring, one end under the right edge of the paring-stone, is in constant use when paring leather.

While it is necessary to have knives ground only from time to time, it is constantly necessary to sharpen up the edges, and even a novice may learn in a short time how to use all the above. It is absolutely necessary to know how in order to save one's self constant annoyance.

*Gold leaf:* There are many qualities of gold leaf in the market—only the best should be used. While it is well to be economical in the use of all supplies, never hesitate to use plenty of gold, for on this, to a large extent, depends the brightness of the tooling. The most brilliant gold of domestic manufacture is known as French No. 1. A box, containing

twenty books of twenty-four leaves each, costs at this date between seven and eight dollars, and lasts a longtime. Single books of twenty-four leaves retail at from thirty-five to forty cents each. The very best quality of gold is the French color "citron." French gold costs almost double the price of domestic. The sheets are a bit larger, however, and thicker, and it is of a higher fineness, so that the real cost is about the same, and it should be used in all high-grade finishing.

*Covering pad:* When leather is well moistened it is easily marred by rough handling or contact with any hard object. "Putting in leather" should be done on a soft surface. It is well, therefore, to cover a full-sized sheet of mill-board with a thick piece of skiver. Place this on the bench and rest the book on it when putting on the leather. A hole cut through one edge allows it to be hung on the wall when not in use.

*Finishing blocks:* These are most useful in tooling, and I call them by this name, though they are in daily use for many other purposes, as, for instance, cutting and pasting down end-papers, etc. The upper surface should also be covered with skiver. The sizes most useful are 9 by 12 by 1 inch, 12 by 14 by 1½ inches, 12 by 20 by 2 inches, but one can get along with one only. (See illustration.)

Another (see cut), covered with skiver, is most useful in laying out and blinding in the straight lines along the sides of the panels. With the back at the upper part, the cover is raised two inches or so to a level—a paperweight or similar object slipped under it. Having marked at head and tail where the outside lines of the panels are to come, a straight-edge is laid on the cover, and with a sharp folder the lines are marked on all the panels at once, so they are exactly in line. The ruler may also be used by the beginner for the preliminary blinding-in of these lines.

Two or three small but heavy weights are needed at all times. They may be small steel blocks such as are used in blocking presses, or of lead. The latter may be had at any large printer's, being run out of old type metal. A very convenient size is



## Practical Bookbinding

3 by 6 inches by 1 inch thick. They should be covered with skiver or stout paper.

*Finishing tools*: The simplest tools are the most satisfactory. Leaves, buds, flowers, should all be separate tools; sprays, flowers with leaves, etc.,

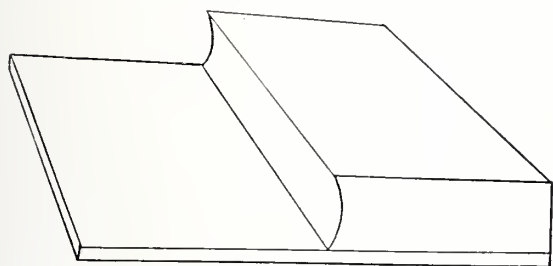

FINISHING BLOCK

all on one tool may be useful for rapid work, but in the end they are less useful. The simple elements (if each is separate) can be combined in a hundred different ways not possible when in fixed combination. Tools with a large surface should be avoided. A single tool having a superficial area greater, say, than one-half inch square, is difficult to use because of the strength needed to make a bright, clear-cut impression. On some leathers, which may be hard and unyielding, such tools result in very unsatisfactory work.

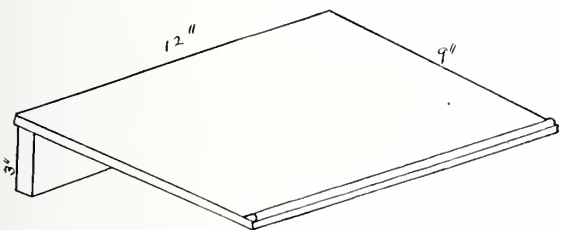

BLOCK ON WHICH EDGES OF PANELS MAY BE LAID OUT AND FINISHED

It is very unsatisfactory, also, to use tools made after the stock patterns which are shown in print by the various tool-cutters. As few tools are ever kept in stock, it is almost always necessary to have them cut, so it is no more expensive to have one's special ideas reproduced, than to have stock patterns cut. The binder should be able to make a drawing to scale, indicating in a general manner at least, what pattern is wanted.

While small tools, such as leaves, small buds and flowers, may be quite flat on the face, the larger tools should be slightly rounded, as it is desirable to rock them from front to rear slightly to get a firm pressure on *each part* of its surface. This rounding should be very slight, however. As each tool is marked on one face of the shank, the binder should

early acquire the habit of using the tool with this mark pointing away from him when used. It will also be convenient to get into the habit of having this marked side of the tool when in use to point towards the head of the book. Unless one has some general habit of this nature, it is not always easy to remember which way the tool was applied when it was used—say for blinding-in. While conventionalized flowers, for instance, may have each petal a duplicate of the others, there are always minute differences, so that the best results are attained if some general rule is followed by which the tool is always *impressed with the same part of it coming just where it did when the original impression was made.*

Tools as received from the engraver may perhaps be used, but it is always best to inspect them carefully with a good glass to note whether the sharp edges have been rounded off—no sharp edges should be allowed. Fillets, gouges, lines, dots, circles, etc., may be rubbed with very fine sandpaper or emery cloth, enough to round slightly the sharp edges felt when the finger is pressed firmly on the margins.

The amateur in the country, or where no engraver is readily available, may be obliged to make many simple tools, such as straight lines, dots, squares, diamonds, etc. All that is needed is a small vise, a few files, sandpaper, emery paper and some pieces of brass rod—round, square or oblong as may be. A person with ingenuity can in this manner help himself out of many a difficulty.

The beginner should be careful not to have finishing tools made by an engraver not accustomed to such work. Many a good engraver may know nothing of the limitations of finishing tools and may produce tools which cannot be used at all; or, if used, work unsatisfactorily. I recently saw a set of tools made in a Western city for an amateur, all of which were so clumsy that they must be recut before fit for use.

Lines, fillets, gouges, etc., should not have a section of wedge shape, but the two sides should be quite parallel; at least that portion which is pressed into the leather.

*Fillets*: These are made of various sizes; 3 to 3½ inches in diameter are most useful. Smaller ones are in use, but experience shows that it is easier to follow a straight line with the large size, and becomes more and more difficult as the size diminishes. As a rule fillets are found in stock with one side quite flat and the other a curve, as indicated at (a). Before purchasing, have it put in the lathe and the edge turned to the shape shown at (b).

## Practical Bookbinding

*Rolls*: These are fillets with wide surfaces, on which an ornamental pattern has been cut. Good binders do not use them, because they do not wish

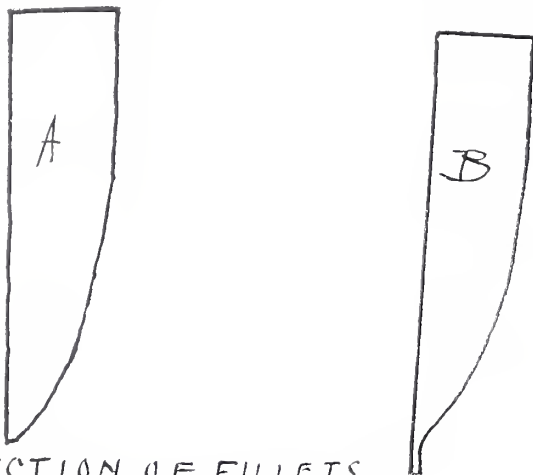

SECTION OF FILLETS  
AS FOUND IN STOCK (A)  
AND AS THEY SHOULD  
BE (B). SIDES PARALLEL.

to use the same pattern on more than one book or set of books. Another objection is, they are quite expensive.

Tools with rounded edges produce more brilliant results than if the edges are sharp and the face quite flat. This is especially the case in straight lines, curves, dots, etc. This is because a flat, gilt surface is not so good a universal reflector as a curved one. A tool with a sharp edge and flat surface makes a depression in the leather which, in section, looks like this:

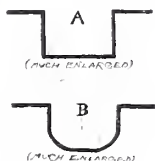

With edges smoothed off and the face (say of a line) rounded, the section is like this:

In the first instance the only reflecting surface is A, and it is only bright when in one special relation to the eye. In the second case the reflecting surfaces are at B, and are brilliant in some one part *at all times*. Multiplying this difference by the hundreds of points of reflection in the average design, it may easily be seen that one method produces a more brilliant effect than the other, *irrespective of the quality of material or work*.

The following styles are ample for a beginning:

- Fillets*: Single line, light.  
Double line, light.  
Single heavy line.  
Double heavy line.  
Very heavy and light combined.

*Straight lines*:  $\frac{1}{4}$  and  $\frac{1}{2}$  inch and 1 inch long should be secured to *match each of the fillets*, the lines being of the same width.

*Gouges*: An indefinite number of these may be had of various curves, lengths and widths of line. I advise the beginner to secure them only as they are needed in the development of his skill. The diagram herewith gives an idea as to curves and lengths to be selected from time to time.

*Lettering*: This may be done by separate hand letters or by means of a pallet and type. Both methods have their votaries and both have advantages. Both also produce good results in the hands of experts, and both may produce poor results in other hands. So one may select the one he prefers. In the United States, type is used in most professional work. Hand letters are used by English binders, and in this country they are employed by those habituated to their use by study abroad. Type is less expensive, and one may have a greater variety for the same outlay. The respective cost is about as follows:

A first-class pallet of good size.. \$6 to \$8

Four fonts of type (brass)..... \$20 to \$25

Lead type, coppered, may be used, and costs from \$1.50 to \$2 per font. Type, both lead and brass, are put up for binders in fonts of 100 letters. Brass type is by far the best, and if possible the foreign article should be bought.

Handle letters cost from \$10 to \$12 per set of 24, plus figures.

As good a binder as Cockerell says one may get along with four sizes of type. I know, however, that some binders doing all kinds of work have a dozen different sizes and styles. Assuming, however, that four sizes are a happy medium, the comparative cost will be about as follows:

Pallet, \$8; four sets type (brass), \$24..... \$32 00

Pallet, \$8; four sets type (lead), \$6..... 14 00

Four sets handle letters..... 45 00

The matter of expense usually settles the question, in the case of most beginners.

Both type and handle letters made in Europe are about one-half the price and better made, so the opportunity of getting such things abroad should not be neglected. Brass type may be found in Europe cut specially deep for binders' use. Recent comparison of such type with the commercial brass type made here, shows the depth of cut of the latter to be not more than one-half that of the foreign make.

*Arrangement of tools*: The various fillets should be held on the wall by means of a rack like this:

## Practical Bookbinding

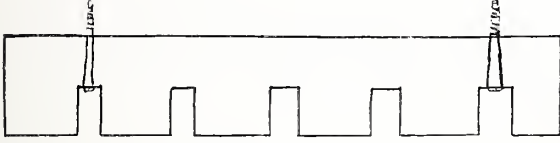

the cuts being about one inch in depth and just wide enough for the shanks of the fillets.

It has been customary to keep finishing tools on shelves or in cases provided with a special space for each tool. This is a very good method, but is costly and takes up much space. After considerable thought and experiment I finally settled on the following expedient: As the average tool is less than 10 inches long, I took a box say 9 by 14 inches by 10 inches deep, open on one side. This I filled with brown paper mailing tubes 1 inch in diameter and 6 or 8 inches long, tightly packed. Each tube holds one tool securely, preventing abrasion with its neighbors and presenting its face for inspection.

A box, 9 by 14 inches, holds about 140 one-inch tubes, consequently 140 tools. The entire expense is one and one-half dollars. The usual racks for the same number of tools cost many times that and take up many times the space. This method is also most useful when need arises to transport a lot of tools for the summer or for demonstration in another place, etc.

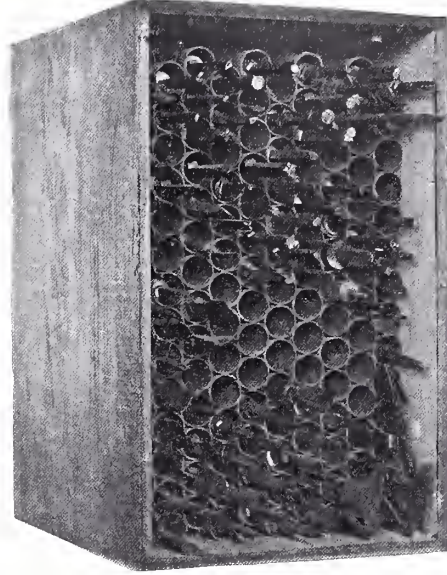

BOX FOR TOOLS

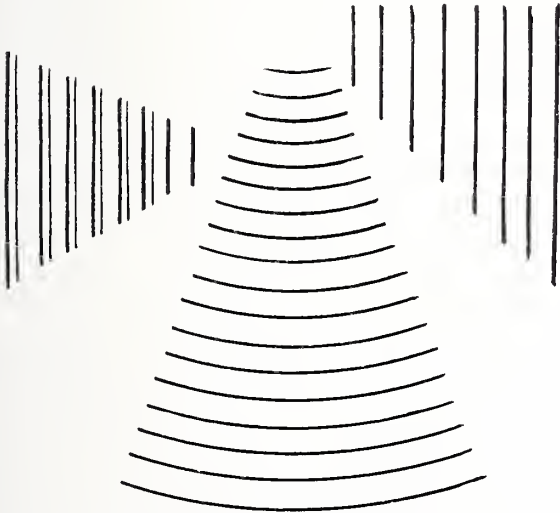
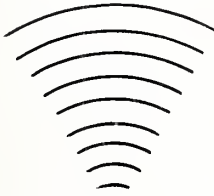

GOUGES AND STRAIGHT LINES

*Mill boards* : This is the technical name under which the various kinds of "cardboard" and "pasteboard" are known in the trade. There is a great difference in quality. The ordinary domestic board is not worth using for good work. The very best quality of domestic board may be used from time to time, but for really first-class work it is best to use the best grade of English or French board.

Mill board is found in the market in bundles of 100 pounds, the number of sheets depending on the thickness of same. The size of the board is about the same (average 20 by 28 inches) in all cases, but the thickness varies very much and is known by numbers. These boards, both the domestic and the foreign qualities, can be purchased at various dealers in supplies of this nature in less than whole bundles, so that it is advisable for the beginner to get a few sheets each, say of numbers 63, 30 and 21. As all boards should be lined before using, it is advisable for the amateur to do this at one time and line the whole stock in hand (if not too great a quantity) in order that they may be ready, and that this operation need not be done from time to time, as it is just as easy to line a number as it is to line one.

## Practical Bookbinding

Sheets of plain white paper—either an ordinary quality of writing paper or other good quality of light paper—of the same size as the boards should be spread on the table and the top one thoroughly pasted with a fairly thin paste. The board to be lined is stood up slanting in front of the operator, the sheet of pasted paper taken by two corners and laid against it. It may now be laid on the bench and smoothed out thoroughly with a brush or a soft pad. Should there be any wrinkles, the nearest corner may be lifted and then let fall back again, smoothing the wrinkles out at the same time. Each board as it is lined is stood up to dry. It will be found that after they have dried they are “drawn” towards the side “lined” and this lined side is the one which makes the inside of the cover. Some binders are in the habit of lining both sides of the board and in this case one side receives two thicknesses of paper—the side which is covered with two thicknesses is the one which forms the inside of the cover. A double lining of this kind is also useful when the board is slightly too thin for the purpose intended, and this strengthens it and also increases its thickness somewhat.

*Paste and its use:* As this is a very important item in this work, it is necessary that it be of good quality and kept in good condition. The amateur worker will do well to purchase it or make it in small quantities only, so as to have it fresh at all times. Ordinarily paste is made by mixing flour and water and boiling it to a somewhat stiffish consistency. The following methods are an improvement, however.

*Paste for ordinary use:* Take one-quarter pound white flour, one-half teaspoonful powdered alum; mix and stir in enough cold water to make a thin gruel. With a spoon or flat wooden spatula rub it up till all lumps have disappeared. Add cold water to make about a pint, and heat it slowly in an enameled saucepan. It should be brought slowly to the boiling point, stirring from time to time. Let it boil a few minutes, stirring briskly the while.

*Paste for mending (Cockerell):* One teaspoonful ordinary flour, two of corn meal, one-half teaspoonful of alum, cold water three ounces. Stir thoroughly with a wooden or bone spoon. Let it come to a boil slowly; it should be kept at the boiling point a few moments, stirring well at the same time; if too much heat is used it tends to turn it a dark color, so this should be avoided. A few grains of salicylic acid stirred in will aid in preventing it from turning sour.

*Rice paste:* Mix a few spoonfuls of rice flour with cold water and boil slowly. A little alum or a

few grains of salicylic acid stirred in will keep it fresh a long time.

*Commercial paste:* In all large centers paste is found on sale; this is made commercially for binders' use and may be had in small quantities. It is usually well prepared and is of good quality.

In using paste the following points will be found useful to the beginner. Paste should always be kept in wooden, glass or enameled ware containers—never in any vessel composed wholly or partly of metal. When thinning paste use water in small quantities and be sure to rub it up thoroughly, so that all lumps disappear and it is “smooth.” There is nothing more irritating than to be bothered (in the midst, perhaps, of a troublesome piece of work) with lumps, or loose hairs from your brush. Use a large brush for paste. Accustom yourself to take up paste on the second or third finger of right hand, and not on the index finger. It is often necessary to use the latter for other purposes at the same time. When pasting a narrow edge always place a clean straight edge of paper on the page, so as to expose only the part to be pasted. This makes a straight edge and protects the balance from soiling. When pasting a number of edges at the same time, place them on each other and “fan” them out so that just enough of each edge is exposed; then place a strip of paper on the upper one (as explained above) and paste the lot. Paste should be used quite thick on leather and when pasting narrow margins, such as end-papers. For lining boards and pasting large surfaces of paper it should be thinner to run easily.

*Leathers:* The majority of fine bindings are made of Levant morocco. Other kinds, such as seal, pigskin, etc., are used from time to time, but comparatively infrequently. There are many qualities of each kind of leather, but nothing but the first grade should be purchased. Although almost all of the better grades of Levant morocco are imported, we find that the American market does not as a rule receive the very finest grades of leather, these being used up in the country of their origin, and a comparatively small proportion is ever exported. At the same time leathers of a good quality can be purchased here.

Some few years ago general complaint was made by librarians and others that the leather used of recent years deteriorated much more rapidly than that which was used in earlier times. An investigation was set on foot by the Society of Arts, and its report (for details see “Bookbinding” by Douglas Cockerell) showed that this was probably due to the introduction of chemical tanning proc-



TENNYSON: IN MEMORIAM: 7x4½

BOUND BY STIKEMAN IN FULL GREEN CRUSHED LEVANT,  
WINE-COLORED DOUBLURE, SILK FLY LEAVES TO MATCH.  
ELABORATE INLAID FLORAL DESIGN ON COVER. SAME INSIDE.



## Practical Bookbinding

esses instead of tanning by the use of vegetable products as in former times. Several leather manufacturers in England decided to change their methods and to produce leather which was tanned entirely by vegetable processes and this leather is known as "acid-free" leather, each skin being stamped to guarantee its quality. This leather does not cost materially more than a first-class article of the ordinary type, so that it is advisable to use it wherever possible. This acid-free leather may be had now in New York, one of the members of the recently formed "Guild of Book-Workers" having it on sale.\*

As a matter of fact, the quality of materials used in fine bookbinding should always be of the first class, because the item of extra expense for each individual book, for materials alone, is so small, and the labor devoted to each book so large a proportion of its ultimate value, that it is not worth while risking a good product by using anything but materials of the very best quality.

*Splitting leather:* Of recent years it has become quite customary to use leather which has been "split"; that is, a certain thickness (known as "skiver") is split off the inner surface of the skin by a very ingenious piece of machinery. The objections to "split" leathers are many; only a few need be mentioned: Much of the strength of the skin is sacrificed, and only the outer part of the skin, which has been hardened by the tanning process, is left. This is not so tough as the inner layers, which are also quite necessary to make a firm resisting medium for tooling. Again, even when split, the skin may still be too thick for a very small book and too thin for a heavy volume. The amateur is tempted to have his skins split, as he usually dislikes the drudgery of paring a thick cover. By selecting skins of varying natural thicknesses much unnecessary work of this kind may be avoided. When I began binding I had my skins split, as I liked the thinner leather—not appreciating the damage I was doing and the difficulties I might have later on, in the way of unsatisfactory tooling, etc. I strongly advise the beginner to use leather of the natural thickness, providing himself with plenty of paring knives (of the very best quality), and to learn immediately how to pare a cover rapidly and properly—it is not difficult under favorable conditions. Again, however thick the cover may seem when handling it, much of this thickness is lost when the book is squeezed (damp) in the press before tooling, to consolidate it and make a firm, smooth surface. I have seen leather

lose from one-third to one-half its original thickness.

### FORWARDING PROCESSES IN THEIR USUAL ORDER

*Trimming sections:* Books are often rebound where the sections have been irregularly folded, so that the fore edges and tail show great differences in depth of sections. It is necessary to trim them to some standard. After the sections are ready for sewing, take the book between the hands, knock the back straight, then reverse and do the same at the head, taking care to keep the book straight; then turn the head toward you, sight along the fore edge and select one section about midway in width between the widest one and the narrowest one; take the section out and measure it accurately with compass from back to fore edge, then knock the book into shape again; sight along the tail and select another section to get the average height. Take this measure also. We now have a standard for height and width, to which all sections should conform; none should exceed these measures, though some may of necessity fall short. We are now ready for trimming. If we have a regularly graduated paper- or board-cutter, this is easily done; no machine, however, being the rule among amateurs, other methods must be used. The following is simple, easily arranged and within the reach of everybody:

A cutting board, or square of mill-board, considerably larger than the section, is laid on the table. Two lines are drawn—A and B—at right angles (use steel square), and at the points indicated by X strong pins or fine wire brads are driven. Care must be taken that these pins stand straight and lean neither to the right nor to the left; the points should go *through* the lines—not alongside. (It is preferable to use a sharp folder to make the lines, as pencil lines are always of varying width and should never be used when accurate measurements are required.) The line A being used as a base line, two points are determined (C C) by the measure previously selected as the standard for the width of the sections. Pins are driven here also. We are now ready for trimming the fore edge. Take one section at a time, place the back against the line A, head against the line B. Place a straight-edge *on* fore edge of section, the straight-edge resting *against* points C C, and with a very sharp paper knife cut off whatever shows beyond the straight-edge. Some sections will fall short and need no trimming. The fore edge is thus equalized.

We now take two more points (D D), using the second measure previously decided upon as the standard for height. Drive two more pins here. Now place each section back against line B, head

\*The author will cheerfully answer inquiries about the "Guild."

## Practical Bookbinding

against line A. With the straight-edge resting upon the section as before, and against points D D, the tail of each section is trimmed, if it projects. Always keep the sections in their proper sequence.

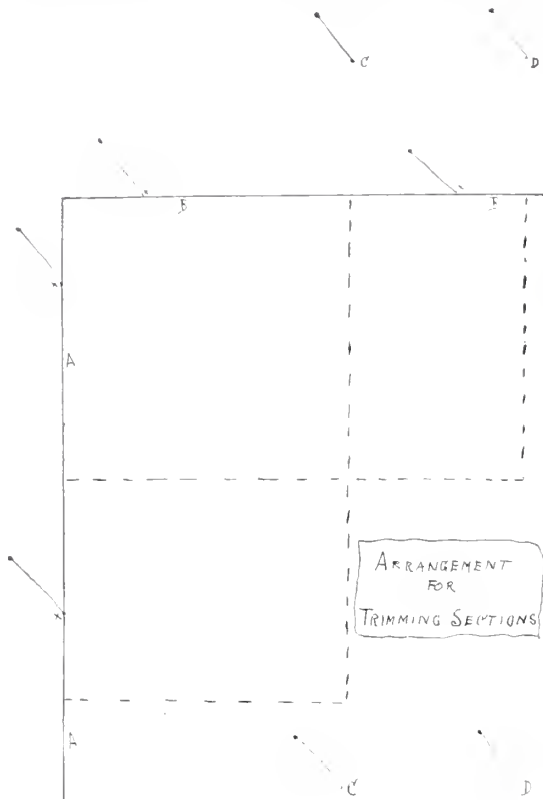

It will now be found on knocking the book into shape that the fore edge and tail present a more regular appearance. It is not desirable to cut much off the fore edge and tail (unless edges are to be

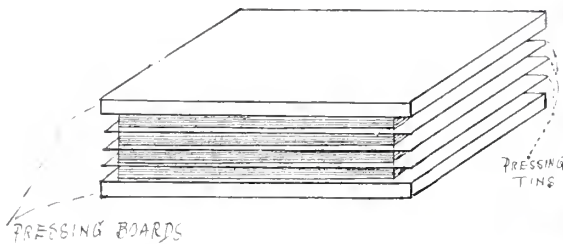

full gilt), especially in books printed on hand-made papers.

In order to have a good surface to trim on, it is advisable to place a strip of zinc on the cutting line—several strips of zinc of various widths and lengths are very useful to have on hand for this and similar purposes.

The sections may also be trimmed by cutting a mill-board accurately the exact size decided upon,

and placing it on each section in order; cut off the projecting edges. This method is satisfactory in expert hands, but the former gives better results in the long run.

*Beating*: Binderies should be equipped with a heavy iron or stone beating block with a beating hammer. The amateur, however, may make shift to do with a heavy lithographic stone resting on a somewhat yielding bed, and the beating may be done with a heavy backing hammer. After the sections have been cleansed of glue and collated, the book should be thoroughly beaten in order to more completely consolidate it—this is especially necessary if it is a new book taken from the ordinary casing. If a thin book (say  $\frac{1}{2}$  to  $\frac{3}{4}$  inch in thickness), all the sections may be beaten at once. If thicker, half of it may be taken at one time. After each half is beaten, join them again and beat the whole book once more. Care must be taken to beat each portion evenly and strike squarely so the edge of the hammer-face never touches the sheets—if it does it will mar them. Beating should be practiced on some useless books. The sections may now be knocked up so the back and head are quite square, placing pressing tins between every five or six sections; the whole is then put in the standing press under the greatest possible pressure and left at least twelve hours

(To be continued)

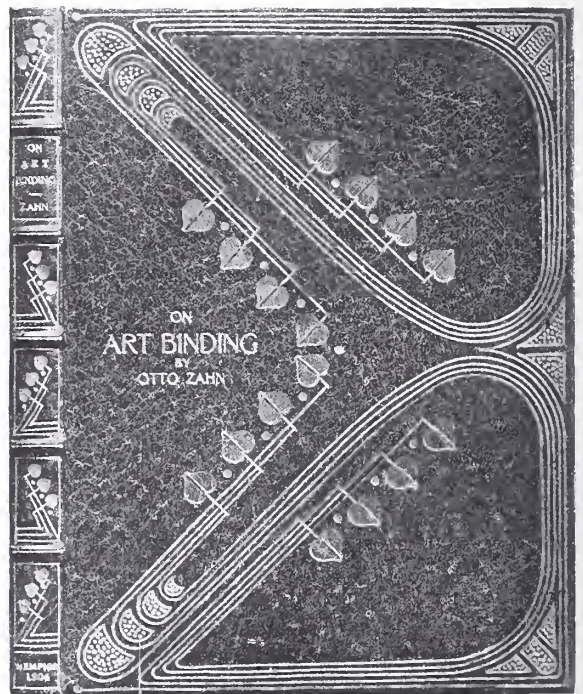

BOUND AT ZAHN BINDERY  
IN MYRTLE GREEN CRUSHED LEVANT

ORIGINAL DESIGN



## The Designer's Approach to His Problem

### THE DESIGNER'S APPROACH TO HIS PROBLEM\*

BY JAMES PARTON HANEY,  
Director of Art and Manual Training  
New York City Public Schools

THE primary purpose of applied design is to add interest to construction; ornament cannot be thought of apart from the thing ornamented. The designer called upon to decorate a given form, never has the problem presented to him abstractly, but always in immediate relation to material and purpose. He is offered a given form, to be made of a given material and so serve some specific purpose. Whatever design he makes must be adapted to the form, suited to the material, and appropriate to the end the model is to serve.

It is to be noted, however, that these questions of space relationship, process and function are not to be developed apart from one another. They demand joint attention. The designer must keep each in mind as he evolves his pattern, he must approach his design from three sides at once, and while making his triple adaptation must seek to secure harmonious relations which shall show interest and variety.

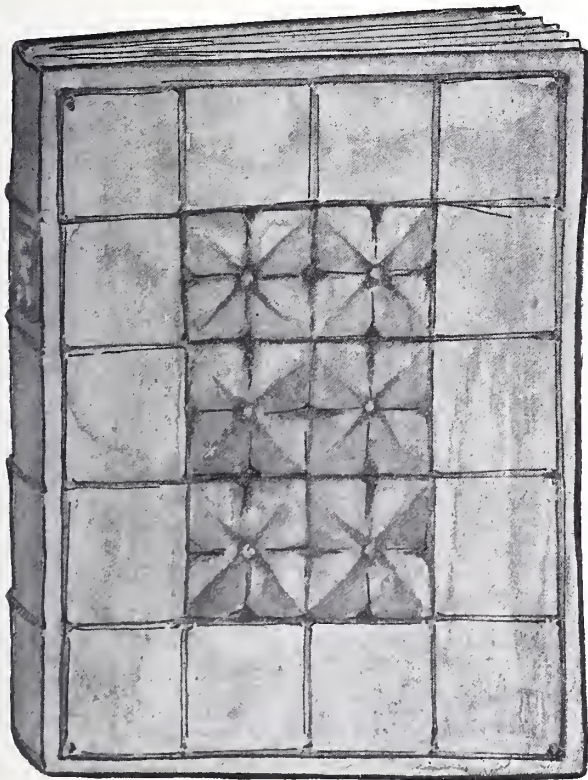

FIGURE I

\* Copyright, 1907, by James P. Haney.

The harmony so developed we know as beauty. It is beauty inseparable from use. No decorative line or mass may be employed without its consideration in terms of structure, material and purpose, nor can such line or mass be used without thought of the part it is to play in the harmony which underlies the whole.

But though this question of decoration is always a question of the achievement of beauty, the statement of definite rules for the evolution of the latter is impossible. Whatever principles may be formulated are true only in a general way, and exceptions appear in them in the work of more than one designer. Beauty, in paradox, is born of many laws, yet knows no law. This is to be remembered in the discussion which ensues. Each of the major principles is developed in some half a dozen minor rules. These may be demonstrated in scores of good examples, yet there is scarce one which will not at times see some design which violates its injunction and yet remains acceptable. Such violations occur in cases which, in enigmatic phrase, are said to "prove the rule." In truth they do not prove the rule, but rather prove that the rule is not universal in application. But while these rules are individually not inviolable, they may not as a whole be disregarded. A decoration may fail to follow literally one of them, and yet may remain a good design, but no design is good which disregards them all.

#### ADAPTATION OF DESIGN TO FORM

The first principle requires that the design be structurally adapted to the form. The decoration, in other words, must complement and support the structure of the model decorated. There follow five statements as to the manner in which such result may be secured: (1) The outlines of the space decorated must be supported by the decoration. (2) The angles of the space must be supported by the decoration. (3) Growth points of the decoration should develop from points of force. (4) Individual constructive elements require individual treatment. (5) Elements which differ in function should differ in decoration.

1. *The outlines of the space decorated should be supported by the decoration.*

The enclosing elements of a space include both lines and angles. These are among the most important agents governing the structure of a pattern. Lines of the decoration paralleling the outline serve to emphasize it. They strengthen the enclosing lines by aiding the eye to follow their movements. Lines which meet the border at right angles do not

## *The Designer's Approach to His Problem*

interfere with its movement, but those which meet or even approach it at an acute angle tend to lead the eye astray. They apparently cause the enclosing line to bend inward. Thus the structural force of the space is weakened.

In Fig. 1 is shown a book cover decorated by a series of lines, all of which parallel and strengthen the borders. These intersections divide the surface in squares. Certain of them have been decorated with rosettes so that the decorative mass as a whole is a rectangle which in its outline supports the enclosing form.

2. *The angles of the space decorated should be supported by the decoration.*

Any element placed in the angle of a rectangular form serves by strengthening such angle to emphasize the squareness of the form as a whole. The decorative arrangement for a rectangle may,

therefore, with propriety be made up in part of masses in the angles. If the rectangle have within it a circular or elliptical panel the pull of the circular lines upon the side of the form will make it desirable, even necessary, to have a counter attractive force in the corners.

In Fig. 2 the structural elements (both lines and angles) of the box have been strengthened by the decoration.

The upper edge of the box has also been made more attractive than the lower by a wider decorative band. This band serves not only to enrich the surface, but to carry the eye upward from the feet of the form to the cover. It conforms to the injunction that "in an upright design the upper part should be made the nobler part."

3. *Growth points of the decoration should develop from points of force.*

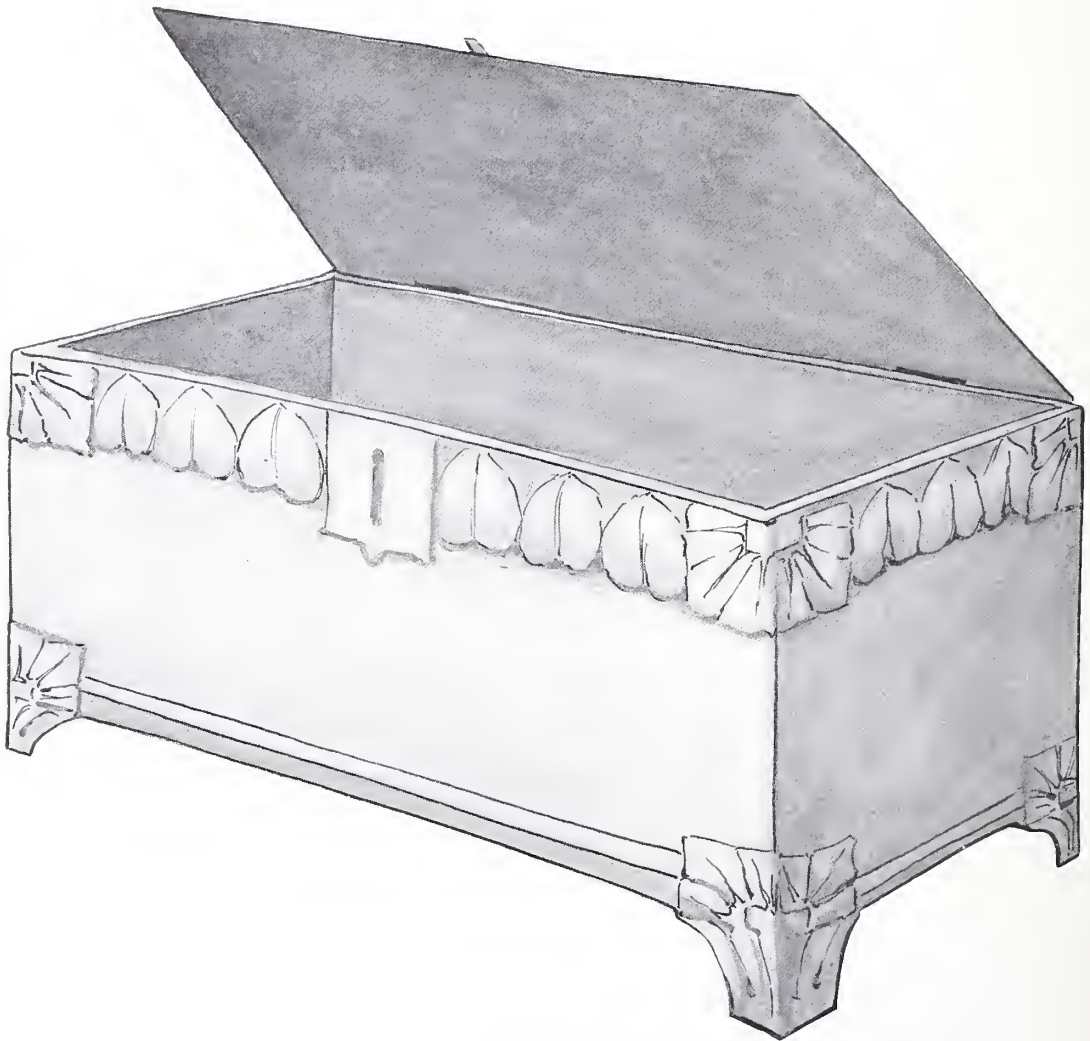

FIGURE 2

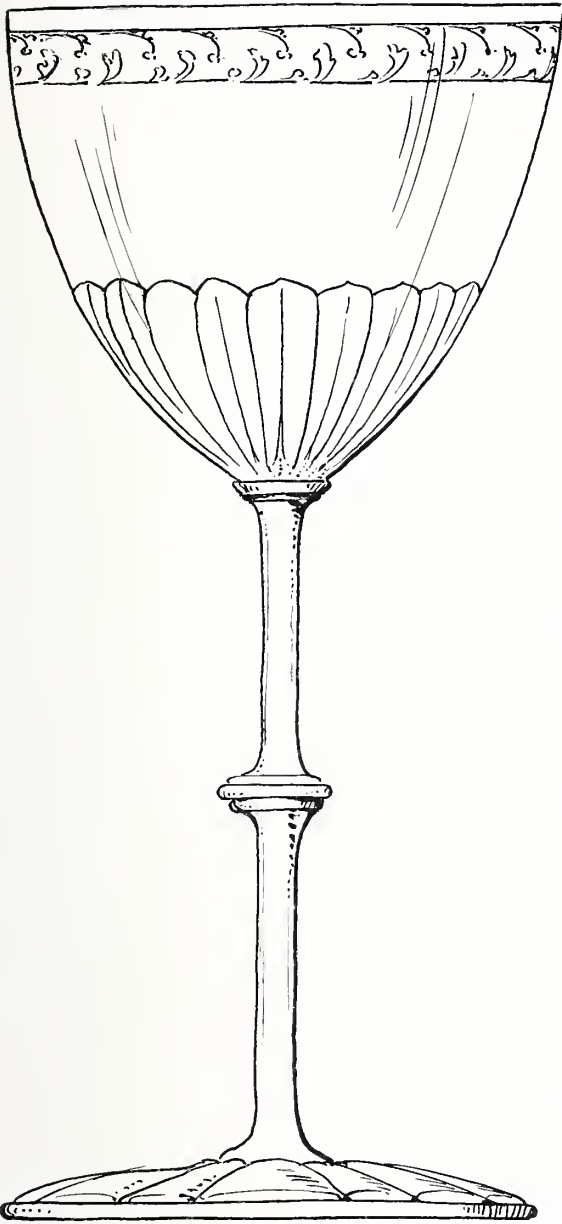

FIGURE 3

Every constructed form may be said to have various points of force; these include angles, joints and elements which hold the form together, as hinges, locks, staples, etc. The points from which a model hangs, upon which it stands, or from which its handles spring form other points of force. From these points decorative elements may properly arise.

Fig. 3 shows a glass goblet with one point of force where the stem joins the bowl and another where it joins the foot. An intermediate point has been created by the fillet on the stem. This serves

to mark the place where the pushing force moves upward to the bowl and downward to the ground.

Fig. 4 illustrates the angle of a form (the metal corner of a blotter pad) used as a growth point. The decoration has been made to express force. Its lines spring outward, and seem to have a vigorous grasping action, as though they would grip the paper thrust beneath them.

While a decoration, however, may properly spring from the growth points of the form, not every point which offers need be utilized. The structural elements suggest a variety of schemes for decoration, but the designer must decide which of these he will develop. To multiply decoration because a number of growth points offer is a mistake. Fig. 5 shows the over-decoration resulting from the use of too many such points in a design.

4. *The decoration of a constructive element should serve to explain its junction.*

Each part or architectural unit of a form should make plain the particular rôle which it plays. This is a principle of all constructive design. The legs of a model must by their placing and their strength make plain that it is their business to bear the weight imposed upon them. Feet if attached to the legs should broaden to grip the surface on which the form stands. The bracket which supports a weight must brace the shelves above. The column must bear its load proudly, its capital swelling to receive the pressure of arch or architrave.

The decoration when applied to each one of these constructive features should help to make plain the service which is performed. The lines upon the table leg must add to its sturdy strength. The claws upon the foot must spread tenaciously. The flutings on the column should carry the eye upward. The leaves upon the capital must show pressure from above borne with ease.

Ease, indeed, is an insistent note in structural decoration. Each part of the model must be seen to be doing its work, but doing it confidently and with no sense of insufficiency. As a corollary of the above it follows that elements of a form which differ in function should differ in decoration. A model so treated will then explain its service both through its construction and its applied design.

In the various forms which have been reviewed there appear a number of examples of decoration depending on function. Fig. 5, though overdecorated, is a typical illustration. It shows the lip of the form supported by a border and the handles strengthened by a linear pattern. Where the latter join the vase they expand into radical or shell-like ornaments, which emphasize the force of attach-



FIGURE 4

ment. In Fig. 6 the threads which hold the book together appear as ridges upon its back. As these are the points from which the force is exerted which joins the separate parts of the book into one, they have with propriety been used as the start points of decorative lines, which spring from them to enclose the cover in their grasp.

#### ADAPTATION OF DESIGN TO MATERIAL

The second principle requires that the design be adapted to the material in which it is to be developed. Five statements follow, which define the manner in which such adaptation may be secured. (1) The character of the material should be expressed in the design. (2) Naturalistic elements should be conventionalized. (3) The limitations of material should control details of expression. (4) The design should lend itself to the technique of the tool. (5) The means taken in expression should appear in the completed pattern.

1. *The character of the material should be expressed in the design.*

Every material has a character of its own, and it follows that that decoration is best suited to it which permits this character to be fully shown. Clay when decorated should express its plastic quality, the ease with which it yields to the spatula or to the hand of the potter. Clay forms are flowing

as compared with those of wood, which in its turn, when carved, should bear the crisp edge made by sharp steel.

It is evident, too, that great differences must exist in patterns designed for mosaics and those intended for woven forms. The little cubes of marble or glass in the one case, and the closely packed threads in the other, necessitate very different forms of expression. The lines of the mosaic must be kept simple, and on each must be felt the impress of the single unit, which multiplied makes the whole. The woven pattern, on the contrary, with its very much smaller constructive unit—a single loop of thread—permits finer details, more refined curves, and a far greater range of color. Every material has some one form of design best suited to it. Metal forms should show the stable and resistant quality of metal, and when fretted or pierced must seek in the decoration the beauty of line and silhouette. When

raised in relief it must show agreeable contrast of light and shadow.

Fig. 7 shows a vase of clay most appropriately decorated with leaves, which will express the plastic qualities of the material. These leaves appear properly a part of the form, not added as an afterthought, but growing up with the shape and helping to emphasize its grace and beauty. Simply modeled in low relief, the lights upon the edges and planes of the leaves cause a soft play of color over the form, without those violent contrasts of light and dark which would result from deeper tooling of more florid decoration.

2. *Naturalistic elements must be conventionalized.*

The designer may employ lines and masses which bear no hint of natural objects, or may use the forms which nature offers on every side in profusion. But such forms he cannot use unchanged. They must be translated into pattern, they must be conventionalized. Conventionalization is not a process, but is a method of treatment. To conventionalize a form is so to represent it that its appearance proclaims its pattern. This process contemplates no necessary stiffening or formalizing of the object, but only its decorative treatment. The nature of the decoration may require that the natural forms used, be represented by the simplest

## The Designer's Approach to His Problem

of symbols, but it is the form decorated that demands the simplification, and not any law of conventionalization.

Fig. 8 shows a tailpiece in which a few flowers and their stems have been woven together to form a design. Both flowers and stems bear only a trace of their natural origin. They offer, as it were, only an excuse for the development of a few pleasing spots and graceful interlaces. The design has been made square and formal in its parts, that it may be well adapted as a decoration to the formal spot in the printed page. To harmonize with its character the flowers have been made as square and as formal.

3. *The limitations of treatment control details of expression.*

Materials differ much in the extent to which they permit the elaboration of natural details. Conventional matter prepared for printed patterns may present a great variety of minor forms, but the same motifs when translated into other materials will of necessity see many of their parts simplified and altered. In more resistant media, as wood and metal, the minor elements will fuse together or will disappear. Material and process thus make it imperative that the aspects of the natural elements chosen for design be made to conform strictly to the limitations of reproduction.

To disguise material in any way so that details of natural forms may be introduced is a mistake. Metal may be engraved or fretted or these processes may be united, but in a fretted pattern not otherwise touched by the engraving tool it would be improper to work out some minor detail of flower and leaf for the sake of

naturalistic fidelity. The designer must demand of his material only that which it can properly do. He must not quarrel with it and seek to force it to do the impossible.

Fig. 9 shows a metal hinge, in which the limitations of material have been frankly met. The structure of the form carries out the idea embodied in it. It is solidly planned with broad base and appropriate bolt holes. The lines of the models swell to show the side and terminal bolts, and so aid in expressing the function of the form. The decoration emphasizes the outline, and offers a suggestion of natural elements, but no more than a suggestion. The form seeks its beauty in its fine outlines, knowing that it can secure no additional credit by the introduction of details of flower and leaf.

4. *The design should lend itself to the technique of the tool.*

Pattern when applied must be developed through some specific process—printing, carving, modeling, hammering, etc. It may be stamped up from below or pressed down from above. It may be sawn out or etched in. Each worker who carries out the



FIGURE 5

## The Designer's Approach to His Problem

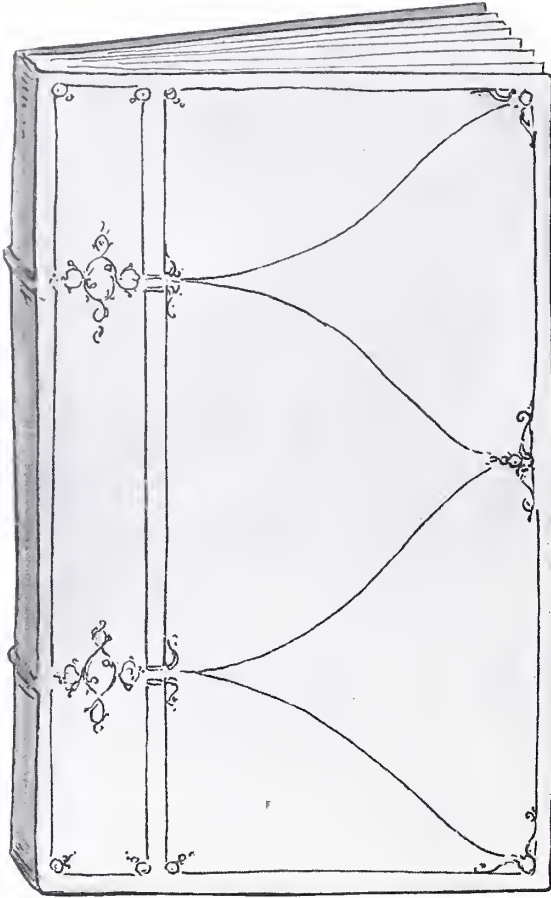

FIGURE 6

plan of the designer has a tool or a score of tools which he must use to reproduce the pattern.

Every tool has many possibilities; the chisel must be used in one way, the chasing tool in another, and the designer must in planning his pattern take cognizance of the limitations of the tool, as well as the material. He must so plan that the tool required, can cope with the difficulties the design presents. Both copper and leather, for example, may be tooled, but the one is worked from below and the other from above. As the two materials are different, so the tools used upon them differ. The matting tool of the leather easily produces a surface scarce to be imitated in metal, hence designs for the one cannot be translated unchanged to the other. Care, too, must be taken that the pattern which is to be developed by the use of some tool allows the latter room in which to work; highly modeled planes with narrow, deep depressions between them must not be so planned in the pattern that they cannot be executed by the tool without destroying neighboring edges which are also in high relief.

5. *The means taken in expression should appear in the completed pattern.*

The decoration which has demanded some process should frankly admit that process. If it has required some tool it should not seek to disguise that fact, but should, as it were, take pleasure in acknowledging the agent which has brought it into being. Designs which are made to be executed by one process should not seek to simulate those developed by another. The decoration to be drawn free-hand, as the old brush pattern of the Greeks, has a character of its own. The pattern to be reproduced by the stenciler has, too, a character of its own, but designs for the two processes are not interchangeable. One is free, one is of necessity more formal. The stencil pattern cannot and should not attempt to imitate the chance irregularities of the free-hand scroll of the Greek border.

If such border is translated into a stencil it should by its formality and its "ties" acknowledge the means which have been taken in its reproduction. Respect due to the tool requires also that the work shall not be obliterated in the finished form. The sharp edges, smart lights and shadows of the carved panel must not be sandpapered down to obtain smoothness and soft uniformity. The hand of the worker should show in his work.



FIGURE 7

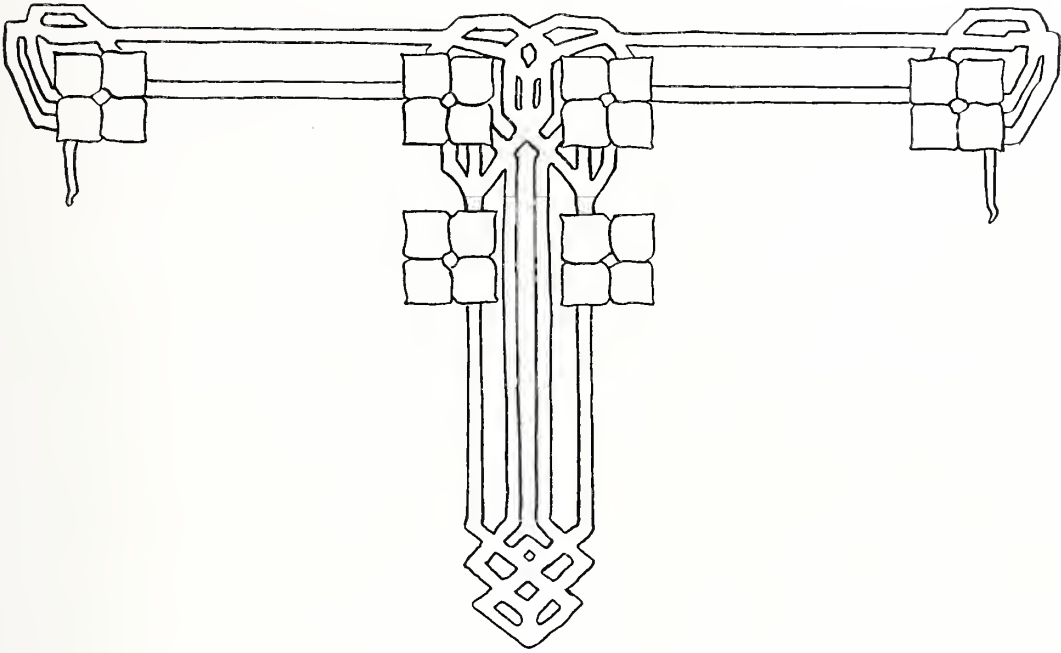

FIGURE 8

#### ADAPTATION OF DESIGN TO FUNCTION

The third principle requires that the design be appropriate to the form decorated. This, in other words, means that the decoration must be suited to the purpose of the object, its use and station. Four statements follow which indicate the manner in which such propriety is to be secured. (1) The decoration should assist in explaining the function or use of the form. (2) The extent of the decoration should be conditioned by the decorative service of the form. (3) The decoration should make no undue plea for attention. (4) Material beautiful in itself should not have its beauty disguised by pattern.

1. *The decoration should assist in explaining the function or use of the form.*

(a) As has already been said, the decoration most appropriate to any form is inherent in the structure of the form. It should not only explain that structure, but should explain the use or service which the form is prepared to render. The decoration, therefore, of the simplest square or triangle should say whether such figure is to lie upon some surface, is to hang, stand, or support some weight. If such requirement is observed, the design will not seem to be added to the form, but will appear, as it should appear, by right, foreseen from the earliest stage of its conception.

Forms subject to some strain should have the fact of such tension expressed in the decoration.

The claw of a table leg should express the force which grips the floor, while the decoration upon the top of the same leg should make plain to the observer (by upward pushing curves) that the leg is staunchly and easily serving its purpose.

Fig. 11a shows a clay tile with a radiate pattern of leaves which move equally in all directions. Such design is suited to a horizontal surface, while that shown in Fig. 11b (a wood block to be printed on a curtain) has an upward movement appropriate to a vertical surface. Both forms are square, but the decoration serves to show how different is the use to be made of each. Fig. 11c shows the square as a jeweled watch-fob made to hang vertically and to express in its every line the fact that it is suspended from a point above.

2. *The extent of the decoration should be conditioned by the decorative service of the form.*

Whatever decoration is applied must always be subordinate to utility. If the object decorated has its use interfered with by ornament, then the design is inappropriate. A form which must be cleansed frequently, as a table-knife, must not have its handle fretted with pattern difficult to keep clean and soon destroyed by frequent rubbing. The footstool, always below the level of the eye, should not have its legs carved into ornaments, never to be seen, but constantly to be subject to the wear and tear of service.

In general it may be said that the more work an

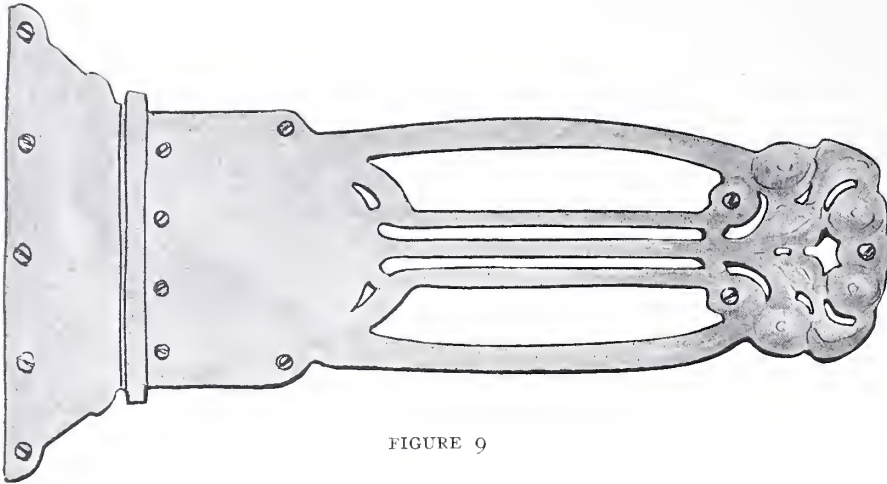

FIGURE 9

object has to do the less should be its decoration. The lowly form should seek beauty in fine line and just proportion; one more distinguished may be adorned in keeping with its surroundings. Thus, jewel-box, paper-knife (see Fig. 12), lamp mat or rose-jar may all see ornament appropriately applied, while spice-box, bread-knife, table-mat or tea-canister are better unadorned. The form which best admits decoration is one which itself serves a decorative purpose.

3. *The decoration of a form should make no undue plea for attention.*

Applied patterns should be modest as well as simple. The means they employ to interest the eye should show reserve. No florid and exaggerated lines and masses should thrust themselves forward. No painfully intricate lacings of stems should puzzle and confuse.

There is a decorative value in open spaces. Not all the surface which offers need be covered with

design. Contrast demands that the intricacy of pattern be relieved by the simplicity of background or panel. Richness is thus emphasized, not by arabesque or scroll, but by the comparison invited between the movement of the pattern and the simplicity of the unfretted surface. Fig. 13 shows a silver bowl in which plain

panel and ornate pattern, balance and enhance each other. More lines and shining bosses would not add to its beauty.

4. *Material beautiful in itself should not have its beauty disguised by pattern.*

This principle stands as a caution to those who would worry fine leather or rich glaze by intricate tool work and unnecessary modeling. Every material has a beauty of its own. A finely grained wood needs but scant ornament, and good carving demands no bristling background wrought with a matting tool. The designer who would excel must not only know his material but must respect it. He must let its beauty vie with the pattern which he himself devises.

#### FITNESS

The three paths by which the designer must approach his problem have been reviewed in some detail. It has been shown that he must plan his design with reference to the structure of the form,



FIGURE 10



## The Designer's Approach to His Problem

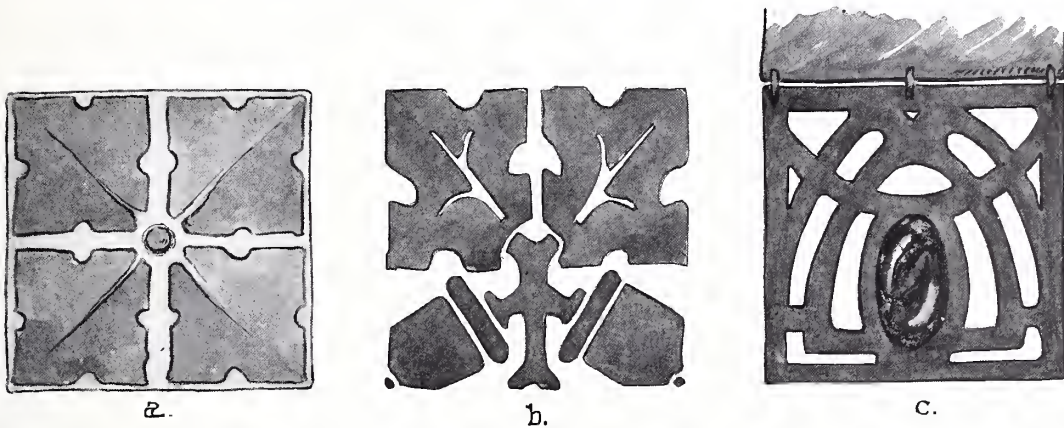

FIGURE 11

that he must adapt it to the material, and that he must consider carefully the extent to which his decoration may be developed with propriety. That which we term "fitness" is a quality developed from consistent observation of the foregoing requirements. Attention to these laws makes for beauty. Disregard of them is one of the chief causes of ugliness.

He who does not consider structure in his pattern introduces lines and curves which meet the boundaries of the form at various angles and weaken it by distorting its elements. His design instead of rising logically from the constructive parts which unite the form as a whole, springs without cause from unexpected and impossible places. So devised it lacks strength. Pattern and structure contradict one another. The form is weakened by the decoration, instead of being aided by it.

Failure to adapt the design to the material leads to further incongruities. One ignorant of his medium or unreasonable in his demands upon it, strives with his decoration to disguise the surface upon which he works. That which should play a legitimate part in the pattern is made to serve merely as a ground or surface to be decorated. So misled, the designer models roses in high relief upon a vase of clay, or causes florid hot-house flowers to blossom vicariously beneath the gaze. In his hands picture takes the place of pattern; nature is made

to play the part of art. Forced thus to serve in place of her convention, she is out of place. No design so conceived can be truly beautiful.

Ugly, too, but in another way, are patterns devised by those who give no thought to the purpose of the object decorated. Overelaboration snares their feet. Forms humble in themselves stand in the sham glory of exuberant design, while dignity and restraint are unthought of in the crude hatchings of cheap metal castings, or the bizarre decorations of the enthusiast armed with chip-carving knife or pyrographic pen. Too few designers see ugliness and overdecoration as terms synonymous.

But beauty, we have premised, is not to be summoned at command. Besides adherence to the principles given, a design to be beautiful requires something more. To be beautiful it must have both interest and variety. Interest depends upon movement, and he who would manage line successfully must know what makes for that rhythm which shall lead the eye from part to part, yet keep it within the boundaries of the pattern. Variety arises from consistent differences in lines and forms. The stereotyped and uniform leads to commonplace. There must throughout the beautiful pattern be nice differences in proportion that the searching eye is ever charmed with the skilful way in which each curve has been varied and each space made different from its neighbor.

Besides interest and variety, beauty demands

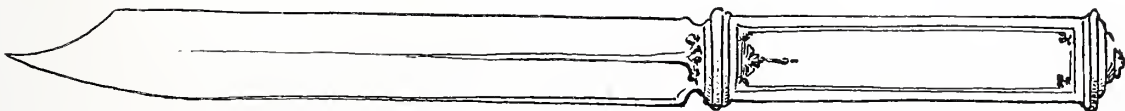

FIGURE 12

## The Designer's Approach to His Problem

unity. Most difficult of all attributes to define, it is first of all to make its absence felt. Unity requires likeness and harmony of relation, yet it does not stand for uniformity. It calls for resemblance in parts, yet demands in them variety. It takes its rise in each design from the character of the main motive and protests whenever motives foreign to one another are woven into the same pattern. Beauty also demands strength. No pattern can be called beautiful which lacks decision. The weak line is an ugly line, and the uncertain scroll and fiberless figure mark the unskilled hand of the tyro.

Thus there rises from the search for beauty that which we call the designer's dilemma. Strength and simplicity the artist must seek, but these lead to emptiness. Interest he must have, but every line that adds to it increases complexity. In the degree in which he possesses a sense of balance, he will escape the dangers of the stiff and formal design on the one hand and the weak and complex pattern on the other.

Last of all, it should be added, there is one element unteachable which must enter into every pattern. We call it imagination. Without it the work of the most faithful student of design will always remain tame and commonplace. It is the spice which flavors all pattern. It is the insight which leads the possessor to make new combinations out of old, the vision sense which permits

the blank and untouched form before him to take on pattern after pattern as he reviews its possibilities before his mental eye. Rules in number have been rehearsed in the foregoing, but beauty does not rise in response to rule, nor can one through printed page tell the designer who lacks it how in his decoration he may display that ingenious fancy, that quaint conceit of form, that playful yet knowing use of line, of mass and color, we know as imagination.

"THE MACWHIRTER SKETCH BOOK" (J. P. Lippincott Company) presents a series of reproductions of sketches in color and pencil from the sketch-books of John MacWhirter, R. A., designed to assist the student of landscape painting in water color. Twenty-four sketches are reproduced in colors and as many are from pencil drawings. The book is intended as a continuation of Mr. MacWhirter's treatise for beginners, "Landscape Painting in Water Colors." An introduction is contributed by Edwin Bale.

Suggestions for work in the older medium are supplied by Alfred East, A. R. A., whose contributions to this magazine are known to its readers in "The Art of Landscape Painting in Oil Color" (Cassell and Company, Limited). The book carries nine illustrations reproduced in colors, twenty in half-tone and thirteen from pencil sketches, etc.

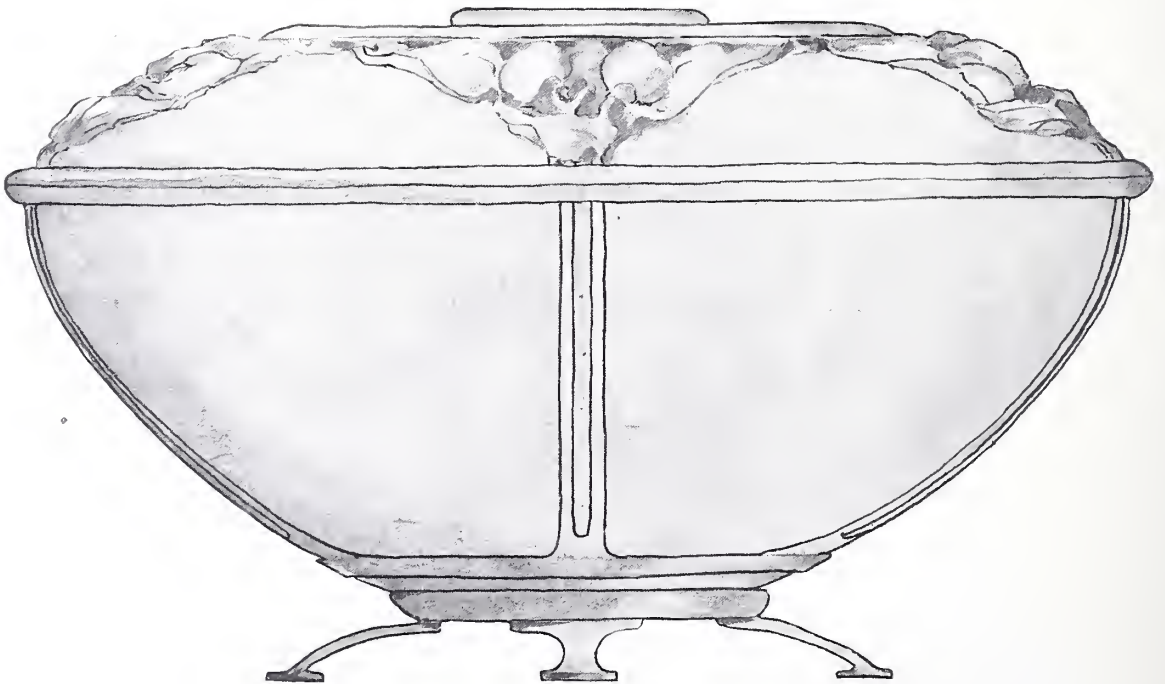

FIGURE 13





"CLUDEN MILL." FROM THE OIL PAINTING BY GROSVENOR THOMAS.

**T**HE LANDSCAPE PAINTINGS  
OF MR. GROSVENOR THOMAS.

THERE are broadly two divisions into which the whole of landscape painting can be separated; into one comes all work that is concerned chiefly with the facts of nature, into the other those pictorial exercises which deal with poetic abstractions and subordinate actualities to large and generalised effect. The purely realistic landscape depends for its popularity upon strict realisation of little things, upon minute care and truth in the representation of details, and it demands from the artist not only much closeness of observation but also a high degree of executive skill. At its worst it is unpoetic and matter-of-fact, merely a plain statement of what is obvious; and it excites no emotion save that of surprise at the patience of the painter who can bore into a mass of trivialities and record them with absolute fidelity. It teaches little

and suggests nothing; it is uninspired and uninspiring.

At its best, however, it can be very definitely interesting, for it is capable of being treated with exquisite sympathy and with a true regard for the dainty charm of nature. In the canvases of Sir John Millais, for instance, the representation of fact was carried to something like perfection. He had an extraordinary power of vision which enabled him to see things in exactly their right relation, and he had consummate technical capacity, by the use of which he could reproduce in a masterly fashion whatever he saw. Nature's fantasy, her largeness of suggestion, and her romantic self-revelation, were in a sense incomprehensible to him; he understood her only when she showed herself without disguise, when she ceased to be elusive and sat simply and frankly for her portrait. But no portrait painter ever set down with more sincere truth all the characteristic peculiarities of his sitter's features, or produced more convincingly



“HOUGHTON MILL”

BY GROSVENOR THOMAS

a credible and honest likeness. Realistic landscape of this sort, and handled by such an artist, could never be passed by as unimportant; it has, and must always have, a right to the most serious attention.

Yet to the imaginative man the landscape painting which concerns itself less with detailed reality and more with the larger truths makes a more stirring appeal. The painter who has a knowledge of facts, but uses them only so far as they will help him to complete his mental impression of the subject he has chosen, is better able to satisfy the student of great abstractions. Turner seems to many people more unquestionably a master than Millais, not, perhaps, because his observation of little things was more accurate, but because he thought more about the largeness and dignity of nature and less about her incidental details. She appeared to him habitually as a kind of vision, exquisite, imposing, sometimes terrible, as a goddess to worship, not as a merely agreeable companion with whom an autumn afternoon or a

summer evening could be pleasantly lounged away. Even Corot, though he fell far short of Turner in artistic intelligence and had nothing like his power of perceiving what were the possibilities of nature study, could rise on occasions far above the commonplaces of detail into dainty suggestion. If Turner's mental image took on the form of a goddess that of Corot was visualised as a nymph, graceful and alluring, but still too remote for harmless intimacies.

The artist to whom this aloofness of nature seems so evident admires her instinctively from afar off, and never seeks to come too near to her for fear that he might by closer contact destroy an impression that he values. He understands that his affections are fixed upon a being that is, and must be, out of his reach, and that if this being were brought to his own fireside the glamour of distance would be gone. He might even find that in possessing the object of his adoration he had lost for ever the power to see anything in her that would be either inspiring or satisfying. So in his



“RAVEY'S MILL, CLUDEN”

BY GROSVENOR THOMAS



"THE RIVER"

BY GROSVENOR THOMAS

work he cultivates the habit of regarding nature with a certain impersonal affection which does not descend to particulars and is frankly worship of an ideal. The only danger is that he may carry this love of an ideal into a pure convention, that he may get so far away from his goddess that he ceases to see her at all, but against this danger the really intelligent man will guard himself carefully, lest he fall into it unawares.

This then is necessary for the painter of imaginative landscape, that he should be a nature lover, that he should know and understand her ways, and that he should at no time allow himself to fall out of the train of her immediate followers, but that he should beware of approaching her in any spirit but that of purely platonic affection. If he wants proof of this necessity, he need only look round within the bounds of the profession he follows; he will find many warnings in the mistakes of his fellow artists, in the dull, unthinking realism of this artist, in the extravagant and incredible fantasy of that one whose dreams have run beyond all reason into a convention which is so unreal that it has ceased to be anything but ridiculous. But he

will find, also, that quite a considerable group of sane workers are setting him a sound example of thoughtful effort to present nature in her best array of ideal graces and under aspects which enhance without exaggeration her greatest charms.

There is, indeed, in existence now a very notable school of painters who have found a thoroughly correct middle course between the bombast of what was once called imaginative landscape and the crude reality which results from visual accuracy undirected by taste, who have learned to understand the sentiment of nature and at the same time to eliminate from their work everything which might clash with this sentiment or diminish its pictorial value. These men work in a spirit of wholesome romanticism, seeing rightly what are the poetic possibilities of the subjects they prefer and expressing by well controlled technical devices convictions which are based upon fundamental artistic principles. The school is modern in feeling and progressive in practice, but its modernity is wholesome and its progressiveness has no "new art" taint; it is a school which respects traditions without being enslaved by them, and yet is fully in touch

with the intellectual developments of the present day.

Among the more distinguished members of this school Mr. Grosvenor Thomas takes a position that is indisputable. He is a romanticist painter in the best sense of the term, and in his work he observes admirably those principles which have guided in the past the better exponents of imaginative landscape painting. Plain and simple realism he avoids; the recording of every-day facts he never attempts, and he does not pretend to be interested in those minor details which are, so to speak, the embroidery on nature's robes. He has a larger aim, an intention to express the sentiment of his subjects by showing their decorative capabilities and by presenting broadly and simply those aspects of them which are most susceptible of rhythmical arrangement, and which lend themselves best to studied design. If any comparison were needed between him and his predecessors it would probably be most correct to speak of him as a follower of Corot, for he has learned something from the French romanticist master. But what he owes to Corot is very far from being the greater part of his equipment; it amounts to little more than a certain elegant facility in the putting together of the component parts of his pictorial scheme. What is most interesting and remarkable in his pictures comes from Mr. Thomas himself.

He is first of all a decorator, who seeks and finds in landscapes which are frankly natural special opportunities for carrying to completion a logical design. About the pattern of each of his pictures he greatly concerns himself; he adjusts lines and masses and harmonises forms, and he plans his colour with the closest consideration for its balance not only of area but also of degree. As a consequence, his work has definitely the charm of suavity and reticence and is attractive both in its grace and its repose; it bears the stamp of scholarly consideration and matured judgment, and there is in its restraint evidence that he has mastered that most perplexing of artistic problems, how to use his material

so as to keep the unessentials from becoming obtrusive.

As examples of this restraint, such pictures as *Evening*, *The Road to Chagford*, *On the Ouse*, and *Cluden Waters*, are of particular importance. In them everything is subordinated to the main design, to the expression of a large idea of nature, and to the broad statement of a decorative intention. The same spirit is evident in more complicated motives like *The River*, and *Ravey's Mill*; they are carried further and they have less simplicity of arrangement, but the placing of the component parts of the composition is quite as deliberate, and the absence of any jarring or restless note is equally perceptible. When he goes further still into work of a more realistic type, and deals with such definite facts as he has set down in *A Devonshire Cottage*, *Cluden Mill*, and *Houghton Mill*, he remains still true to the principles which govern his entire practice. In these last pictures he has filled in his pattern more elaborately; he



“THE ROAD TO CHAGFORD”

BY GROSVENOR THOMAS



## Grosvenor Thomas



“ON THE OUSE”

BY GROSVENOR THOMAS

his own practice. During the time he spent in Scotland he fell under the spell of the art which has grown up in that country during the last hundred years or so, and to its traditions he has remained more or less faithful ever since.

Yet in responding thus readily to the influence of his surroundings he has not surrendered his liberty to think for himself, and he has certainly not sacrificed his individuality. The sentiment of his work is Scottish but with a difference, and for that difference his per-

has added more explanatory touches and has made more concessions to the popular demand for actuality, but his love of studied design has kept him just as surely from obviousness and from the bald commonplaces of the unthinking and uninspired painter.

If, however, his art owes much of its persuasiveness to his decorative sense, it owes hardly less to his appreciation of the subtleties of romanticism. He possesses an ample measure of that romantic sentiment so characteristic of the Scottish school to which he belongs by association, though not by birth. A self-taught painter, trained in no school, and developed under no guidance save that of his own intelligence, he gathered his knowledge of art when and where he could. He has studied Corot and Daubigny and the other Barbizon masters; he has looked long and closely at the modern Dutch painters, but he has found in the earnestness and sterling sincerity of Scottish painting the best model for

sonal preferences are accountable. His colour sense is purely his own, his instinct for choice of subject is natural to him, and even his romanticism,



“EVENING”

BY GROSVENOR THOMAS



"A DEVONSHIRE COTTAGE"

BY GROSVENOR THOMAS

Scottish though it may be in its origin, is now modified into something which expresses a good deal more than his belief in the creed of a particular group of artists. He looks at nature with independent vision, with a desire to understand her himself rather than with the wish to see in her only what others have already discovered. The strength of his art is that which comes from a vigorous and masculine personality, but a personality of which the robustness is at all times restrained by a love of great æsthetic principles and by more than ordinary tenderness of poetic feeling.

Mr. Grosvenor Thomas can best be described as an artist who has sought in many directions the materials he needed for his equipment but who has succeeded in combining these materials so judiciously that he has made with them something that seems to be wholly original and peculiar to himself. Many other men have had opportunities quite as great of acquiring knowledge, but few have been able to use them to such advantage.

W. K. WEST.

AN AMERICAN  
PORTRAIT-  
PAINTER,  
WILTON LOCK-  
WOOD.

It was at the Champ de Mars, in the spring of 1904, that the work of Wilton Lockwood received its first important notice in the exhibition of six characteristic examples. These six paintings did not fail of instant attention; the power that was behind them was unquestioned, but, as is inevitable with any decided venture into untried fields, they

received their natural quota of suspicion as to their depth of sincerity. In the following year, however, we see him meet with unqualified success, observing that his misty *enveloppe* was not of an ephemeral and superficial nature, that it was not a manner or a trick but that it had been evolved as a serious means of expression. That it served his purpose adequately, the critics were ready to concede and with the admission



"CLUDEN WATERS"

BY GROSVENOR THOMAS

## Wilton Lockwood

that it had not been employed as a cloak for shirking.

The same year saw paintings by Lockwood in the "Secession" exhibition at Munich, and in the triennial exhibition of the "Grosse Berliner Kunst-Ausstellung" of the German capital. In both places the appearance upon the arena of a vigorous, original and, at the same time, subtle painter, was hailed with unreserved enthusiasm. The portrait of Mrs. Lockwood, shown in Berlin, was regarded as being in the first rank of modern art.

It had been a hard road—ten years, chiefly spent in Paris, of incessant labour under the direction of eminent European masters. Then came the desire to follow up this foreign success by a career in the artist's native country. Accordingly, after duly considering what, to him, would be the most congenial surroundings in his mother country, he decided finally to locate in Boston; and it was in Boston the year following his triple success abroad that he set the critics agog by his exhibition at the St. Botolph Club, styled, according to the catalogue, *A Collection of Portraits, Studies, and Notes*. This epoch-making display was arranged to remain for a two-weeks' showing, but, in consequence of its enthusiastic reception, was continued for another week. Everywhere "the new man" was the talk of the hour. Viewed askance by the conservatives, wildly acclaimed by that certain element which is constantly in search for sensation, honestly admired by discriminating, thoughtful judges, he nevertheless was candidly acknowledged by all as an innovator, a man of marked ability, and one who was striking a decidedly personal note.

After this exhibition, one appearance in a notable gathering succeeded another; the genius of the man began to find its proper level until, some twelve months later, Mr. Lockwood received for *The Violinist* an honourable mention at the Carnegie Gallery at Pittsburg; and by the Pennsylvania Academy of Fine Arts at Philadelphia he was awarded a Temple gold medal for the same painting, which is now at Skibo Castle, Scotland.

The painting so honoured was a remarkably sincere character interpretation of the *virtuoso*, Otto Roth. That it is an adequate likeness, the best critics agree, but it is far more than a superficial likeness. It is straightforward and refined. It is a worthy description of the man, but the man at his truest and best—as the musician.

Of Mr. Lockwood's portrait examples, the one of ex-President Cleveland is a frankly meritorious work. It is a scholarly rendition expressing sympathy of thought and feeling between subject and

artist. Executed on the regulation coarse-webbed canvas, it defines a certain confidence and eager directness of brushwork which command unqualified attention. It represents Mr. Cleveland, not as the chief magistrate of his country, but Mr. Cleveland as the retired citizen, the scholar and thinker. And, for a convincing understanding of the sitter, the portrait of John La Farge, Mr. Lockwood's old master, is notable. Nothing but the warmest affection could inspire such a work, containing as it does the impress of the sensitive, penetrating and alert characteristics of La Farge himself.

Another justly notable work is the spirited



FRANK SEABURY, M.F.H.

BY WILTON LOCKWOOD



MR. A. J. CASSATT

BY WILTON LOCKWOOD

for the Myopia Country Club. Dressed in the regalia of the club, the horn, which is the badge of office, protruding from his waistcoat pocket the man as a sportsman is conscientiously portrayed. For dash, for soundness of understanding and fluency of brushwork, this achievement is perhaps second to none of Mr. Lockwood's works. Mr. Cassatt is represented as a man of affairs, a man whose interests are objective, rather than subjective. Standing with one hand in his pocket, the other holding a whip, his hat and gloves, the figure imparts a striking impressiveness of appearance against its softly harmonious ground.

If it be urged that Lockwood is a colourist pre-eminently, attention should be called to his marvellous refinement and beauty of line, when considered wholly from the standpoint of pure grace. See the subtle juxtaposition of lines in the portrait of Mrs. Sweetser. It is poetic, it is musical—it is all that dignity and subordination demand in the psychology of art.

At once an idealist and an impressionist, the temper of Wilton Lockwood is most profitably seen through the mirror of his works, where we may discover him at times elusive, delicate at others, and again virulent and even dramatic. His freshness of invention shows itself in the delightful spontaneity with which he approaches each new subject.

Apart from the honours previously mentioned as having fallen to this talented painter, he was awarded a silver medal at the Paris Exposition of 1900, another at the Pan-American Exposition of 1901, and still another at St. Louis, 1904. He is an associate of the National Academy, a

portrait of Frank Seabury as master of the hunt, which was executed within the space of four days

member of the Society of American Artists, as well of the Copley Society of Boston. M. I. G. OLIVER.



MRS. SWEETSER. BY  
WILTON LOCKWOOD



"THE VIOLINIST" (OTTO ROTH)  
BY WILTON LOCKWOOD

*(By permission of Andrew Carnegie, Esq.)*

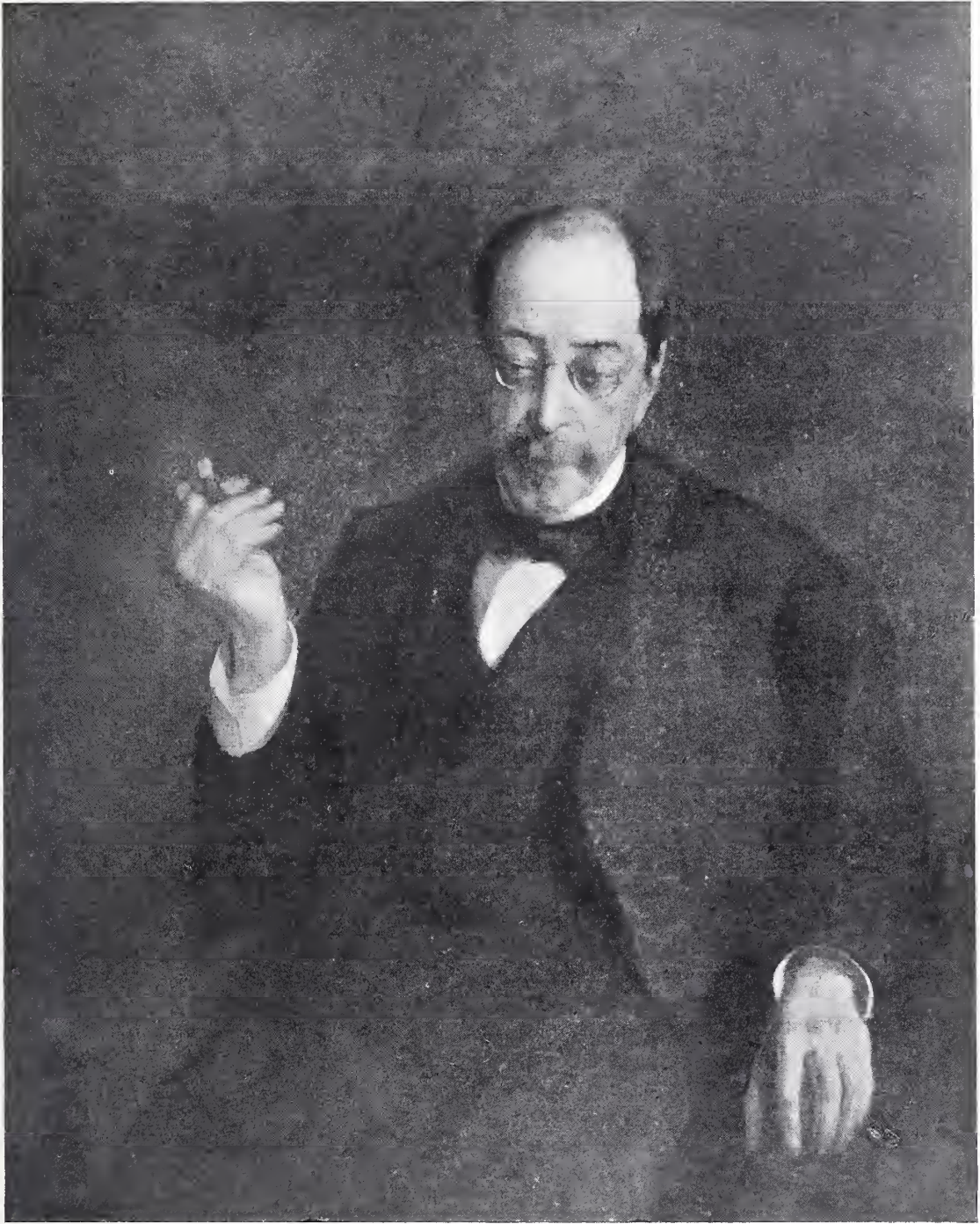

JOHN LA FARGE  
BY WILTON LOCKWOOD



THE HON. GROVER CLEVELAND  
BY WILTON LOCKWOOD





VENICE EXHIBITION

(Photo. A. Tivoli)

THE VENETIAN ROOM

## THE SEVENTH INTERNATIONAL EXHIBITION OF ART AT VENICE, 1907.

THE exhibition of modern art now being held in Venice is generally considered the best, both for quality of work exhibited and for sales effected, of the whole series. The foreign sections especially are this year admirable in selection and arrangement; but I can also note considerable advance all round upon the exhibition I visited in 1905. Venice herself, for centuries a world-centre, first of commerce then of art, then later of pleasure, is the ideal location for such an international exhibition, and in Sgr. Fradetto, with his untiring energy and sound judgment, she has found a no less ideal director.

My subject here is extensive and my space limited, so I come at once to the Sala Centrale, whose walls are entirely devoted to the decorative panels of Aristide Sartorio. The artist has sought here "to illustrate, with the myths of classical antiquity, the poem of human life," and it has taken him

two pages in close type of the catalogue, with the aid of "four hendecasyllabic legends" to explain to us what it is all about. As decoration these figures in monochrome—dark green and brown and black—have great merit, but do not entirely harmonise with the room; and again, they are terribly uneasy; whether nude or draped, whether they treat of human passion or the silence of the tomb, they are alike restless, perturbed, destitute of any sense of repose, which surely sometimes belongs to their theme. The

colour scheme, however, is pleasing and perfectly under control, the drawing of the nudes—in which I venture to trace something of Leighton's influence—exquisitely delicate, delightfully vivacious.

Having studied Sartorio's paintings we may glance at the sculpture in this room, where we shall find, with Auguste Rodin's *Penseur*, a *Fecondité* of the Belgian Meunier (the last work before his death); and here, too, Max Klinger has an upright female figure, *Baigneuse*, where the sincerity of the modelling, the solidity and power of



VENICE EXHIBITION

(Photo. A. Tivoli, Venice)

THE GERMAN ROOM

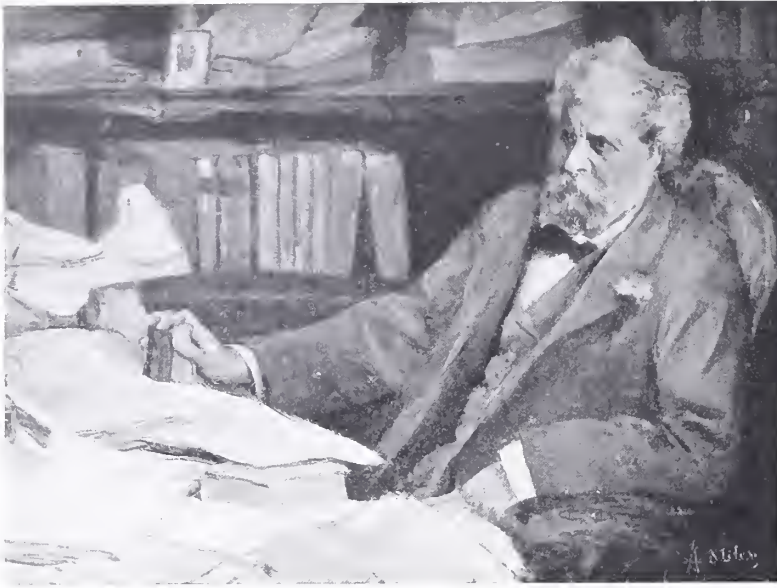

PORTRAIT OF GIOSUÈ CARDUCCI

BY ALESSANDRO MILESI

the treatment contrasts with a subject which is so often a synonym for superficiality.

The Norwegian room need not detain us and we may make our next halt at the Austrian Sala. Here, in place of the gold of two years ago, white is the keynote of the decoration, for which the Hagenbund of Vienna is responsible. The effect is cool and fresh, and ample space is given for the pictures; but these are frequently more like studies than finished works. I do not speak of Walter Hampel's clever *Dwarf and Woman*, where the influence of his master, Mackart, appears; nor of August Roth's *Autumn*; but what shall we say of the paintings of Preisler, of Uprka or Jan Stursa, whose young girl in bronze, a *Puberté*, has the faults of the beginner—over elaboration of detail and complete lack of *ensemble*? The majolica by Powolny is very attractive.

In the French room we at once pick out some paintings of real merit, such as Besnard's portrait of M. Barrère, the French Ambassador in Italy; Carolus-Duran's male por-

trait; and, still more, J. P. Laurens' *Portrait de mes Parents*. But the artist who really shines in this room is Blanche, whose *Venetian Glass* was one of the successes of the last Exhibition. Here he has a lady in travelling dress—*La Voyageuse*; an English portrait (*Mrs. Montgomery Lang*), and, above all, his delightful *Cherubino*, where the technique (especially in the hands) is as easy and almost as brilliant as that of a Sargent. Curiously enough the nudes are the weakest part in the French room. How entirely conventional is Fantin-Latour's

*Eve*; and when even Carolus-Duran paints a lady with bright red hair, upon a still brighter crimson plush divan, one is tempted to ask (under one's breath, before such a known master) whether flesh is not, in its way, as recipient of surrounding colour as a mirror, and whether it is conceivable that this young person, unless she had been carefully enamelled all over before posing, could lie amid such glowing surroundings without some resultant reflections being apparent in her flesh tints?



VENICE EXHIBITION

(Photo. A. Tzoli, Venice)

THE RUSSIAN ROOM



THE ENGLISH ROOM, VENICE  
INTERNATIONAL EXHIBITION

(Photo. by A. Tiròli, Venice)

## The Venice Exhibition, 1907

The Swedish room is one of the very best in the whole exhibition. Here we have Zorn in his wonderful *plein-air* studies: we have Carl Larsson, whose *Martina* is included among our illustrations; we have the northern fauna, the birds and seals of Axel Sjöberg, and, above all, we have the work of that wonderful colourist, Anna Boberg. Anna Boberg has here twenty-one paintings, among which I should specially mention *The Modern Vikings*, of which an illustration is given (p. 274), *The Mysterious Moment between Day and Night*, and the *Cemetery*, which seems a rendering into colour of that scene from *Ossian*, which Goethe has described "the farthest Thule, where we wandered over grey, endless moors among moss-covered tombs, while a terrible wind stirred the grass, and a heavy clouded sky lowered upon us," and where, in the dim moonlight, departed heroes and love-lorn maidens seemed to hover over the wind-swept

graves. With Zorn, however, we seem to recover touch with actuality, but actuality in another way idealized: he is the magician who reveals to us mysteries of light and form which were unknown to us, though always within our reach. His *Ruisseaux* here recalls the *Reflets* of the last exhibition; like that, it is a study of the reflections of water as affecting and affected by a nude figure in movement. In another nude the artist has studied the contrast (which often occupied that Venetian master of colour, G. B. Tiepolo) of the golden white of flesh with the dead white of drapery. His *Rêve de Printemps* is a really idyllic vision of a fair-haired girl, bathed in sunlight, moving across a scene in which we seem to feel the stir of the summer wind upon some northern coast.

Equal in interest to the Swedish Room is the English, and it is satisfactory to find the opinion of the Venetians themselves placing these two rooms



"BEFORE THE MASKED BALL"

(Photo: C. Naya, Venice)

BY PHILIPP KLEIN



“LA TOILETTE”

(Photo. C. Naya, Venice)

BY CAMILLO INNOCENTI



“LOVE AND LEAVES”

(Photo. Philippi, Venice)

BY P. NOMBELINI

at the front of the foreign sections. Both have individual character, and in both the work has been very carefully selected. To reach the English room from the Swedish we have to traverse the German sections, two rooms which, though they include abundant works of merit—I might instance Otto Marcus's brilliant study of a dancing girl, *Miss Allen* (reproduced in *THE STUDIO*, November, 1906), and Philipp Klein's *Before the Masked Ball* (p. 272)—have not the distinctive character of either the room we have just left, or of that which we now enter.

In this Sala Inglese, J. Sargent's six magnificent portraits arrest our attention the moment we enter. The *Lord Ribblesdale* is probably one of the finest portraits he has ever painted. A captiously sartorial critic might perhaps hint that the noble lord's clothes seem all a size too large. But no such remark could be applied to the three-quarter length of *General Sir Ian Hamilton*, with its indefinable air of distinction, or to the seated portrait of the President of the Royal Institute of British Architects. Next to Sargent, Mr. John Lavery is the most fully represented of modern British artists. Among his five paintings here *On the Rocks* and *Chou Bleu* (p. 275) were, I found, special favourites among visitors to the exhibition.

Fine in character as is this work of Sargent and Lavery, one feels some regret that more space could not have been found for a wider and more catholic view of modern English art—especially of those younger men whom the critic should always be ready to watch for and welcome. Mr. Orpen is represented in the exhibition by a brilliant study of *A Spanish Girl*, but not in the

English section; and the same may be said of Mr. Shannon. We may be grateful, at least, for a painting by Alfred East, *London by Night*, which is of exceptional interest, since it is quite away from his usual subjects and methods.

For the decoration of the English section Mr. Frank Brangwyn has been responsible, and his four panels keep their place admirably in the decorative scheme. It was, however, his etchings in the adjoining black-and-white room (I noted especially his *Old Houses at Ghent*) which were a revelation to me of his powers in this branch of art, in which he is well supported here by Alfred East and Joseph Pennell.

What, it may be now asked, are the modern Italians showing this year, for, after all, their own work must form the *pièce de résistance* of these biennial exhibitions? There is no doubt that they

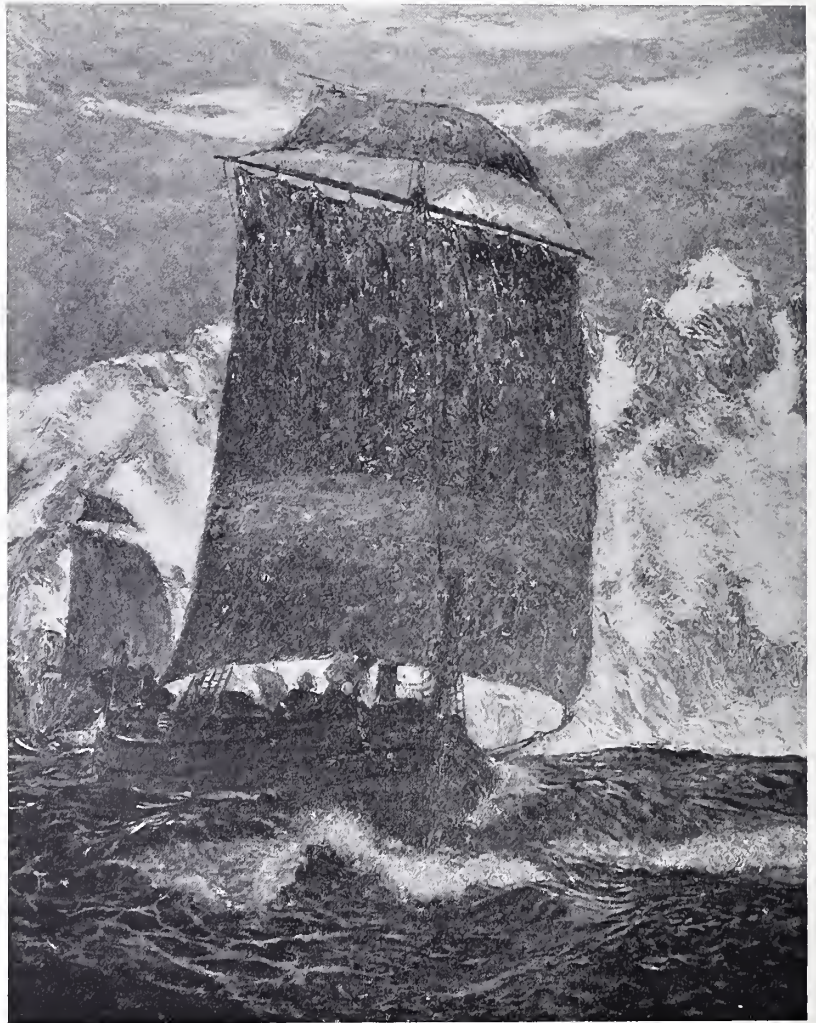

"THE MODERN VIKINGS"

(Photo. C. Naya, Venice)

BY ANNA BOBERG



"CHOU BLEU." BY  
JOHN LAVERY



DECORATIVE PANEL BY A. SARTORIO  
(Photo. Giacomelli, Venice)

have learnt some very useful lessons from this artistic invasion from beyond the Alps. "From Rodin to Sargent," says one of their own critics, "from Meunier to Brangwyn, from the Scotch group who came forward in 1897 to Zuloaga, who appeared on the scene in 1901, how many foreigners have in these few years conquered the sympathies of Italian art! And if in the foreign rooms we come at every step upon originality which is almost tedious, almost presumptuous in its self-assertion, in the Italian rooms we are struck more especially by ill-concealed imitation, by souvenirs which are

pleasant but overpowering, and by too assertive reminiscences."

Our survey must here be a rapid one, and, taking first the Sala di Roma, we find ourselves before Coleman's and Onorato Carlandi's Roman landscapes, the latter's *Sur le rivage d'Ostia* being very admirable in its reserve and sense of values. Mancini's wonderful portraits, always vivacious and full of colour, Noci's charming pastel of a nude figure, a decorative triptych (*Horses of the Sun*) by De Karolis—all these are to be noted. Battaglia, who figured well in the last exhibition, has here a study of a country girl, and Camillo Innocenti a charming work *La Toilette* (p. 273).

In the Piedmontese Room I noted especially the work of Giacomo Grossi, but the Sala Lombarda arrested my attention, because here is a school which has in it the elements of progress. Carcano, who has two paintings here, is a known figure among the Milanese; and I



"MARTINA" (Photo. C. Naya, Venice) BY CARL LARSSON



## The Venice Exhibition, 1907



“ SAND-CARRIERS ”

BY FRANCESCO GIOLI

would point out a clever painting by Emilio Gola, *Beside the Wharf*, as well as Borsa's *Winter Evening*.

Passing through the Sala Emiliana, with Majani's charming moonlight study *Le hameau dort*, and Scattola's *Assisi*, we come, in the Sala Toscana, to the art of modern Florence. Here Luigi Gioli comes before us with his *Volterra Fair* and his clever study of horses in the Pisan plain treading out the corn. Here, too, are Nomellini's *Love and Leaves* (p. 273), Francesco Gioli's *Sand-Carriers* (above); and near it is a sunset, very good in colour, and a group of naked children dancing on the Tyrrhenian strand, which he calls *Youth*.

In the South Italian room De Maria Bergler's studies of *Taormina* (the smaller are here the best) and *Viole* are to be noted, with the work of De Sanctis and Tafuri. And now we come to the Venetians themselves. Dall' Oca Bianca and De Blaas have wandered off into the South Italian room—the latter almost too smooth and sweet in his *Girls of Campalto*, the former full of piquancy and vivacity in his *Civette*.

In the first Venetian Room Laurenti figures largely with eighteen canvases. The most attractive to me is his *Ritorno*, a girl in green dress, where the whole conception seems reminiscent of Palma Vecchio. Laurenti is no longer among the younger men (he was born in 1854), but is a fine and serious artist, who has followed his art into other branches, such as sculpture and even architecture.

In the next Venetian Room (Sala XXV.) we shall notice the work of the three Ciardi. Beppo, the younger Ciardi, has here a canvas full of light in his *Sourires*; but personally I find myself strongly attracted by Signorina Emma Ciardi's *Paroles Antiques*, where the terrace, with its white sculpture and monumental cypresses, with its masked figure from the Venice of Goldoni, has something of the indefinable charm of the great Böcklin's *Tödten Insel*. Here, too, that excellent Venetian artist Vincenzo de Stefani, who figured well in the last exhibition, has two paintings, a study of a young girl in white and a beautiful sunset, *The Evening Harmony*. Here, too, is Milesi's portrait of *Giosuè Carducci*, the poet whom all Italy this spring has mourned (p. 270); and here Vizzotto, in his *Sirènes*, gives just the impression of a “burrasco”—a squall such as sometimes comes up at short notice on these lagoons; while Sormani (*Sur le Môle*) has a quieter scene of nightfall at Venice.

Of the sculpture in these Italian rooms I need not speak at any length. The central group in the Roman Sala, *La Vendange*, with its figures of men and a girl, is ambitious and sound in modelling. But one of the most delightful things in the whole exhibition is a little bronze of a dancing girl, *Printemps*, by Rosales. This gem has been secured by the State for the National Gallery at Rome. Antonio Ugo, whose group of a peasant mother and child (*Maternité*) is among our illustrations, (p. 278) also claims notice. Ugo is a Sicilian, and



“MATERNITÉ”

BY ANTONIO UGO

among present-day Sicilian sculptors he is perhaps distinguished by the greatest endowment of real genius. “Modest and retiring,” writes Mr. Sidney Churchill, H.B.M.’s Consul at Palermo, who has followed Ugo’s work with keen interest, “very little is seen of him professionally. His studio is a workshop and not a show-place” Recently, when King Edward VII. was at Palermo, His Majesty much admired Ugo’s work, and ordered that one of his latest productions should be sent to Buckingham Palace. It is interesting to recall that Sicily was renowned for its plastic creations in early ages—even before the days of the Roman Empire medallists of Catania and Siracusa had become famous.

The Sala Russa, with Seroff’s portrait of the *Emperor Nicholas II.*, in the uniform of the Scots Greys, and Maliavin’s multi-coloured peasant women, must be traversed ere we leave the building, and outside we find a feature of new interest in the Belgian Pavilion, arranged by Professor Gevaert. The entrance, with its amber-coloured marble and its fountain, at once delights us, and within we find a very well chosen selection of the modern Belgian school. In the smaller rooms I was delighted with a triptych in water-colour, *Bruges of the Old Times*, by Ferdinand Khnopff; and found near him seven drawings by that genius of moral obliquity, Felicien

Rops, besides the faultless figure etchings of Armand Rassenfosse.

SELWYN BRINTON.

The following Canadian artists have formed a group to be known as the Canadian Art Club:—Homer Watson, R.C.A. (Doon), Franklin Brownell, R.C.A. (Ottawa), William Cruikshank, R.C.A. (Toronto), Curtis Williamson, R.C.A. (Toronto), Edmund Morris, A.R.C.A. (Toronto), William Smith, A.R.C.A. (St. Thomas), W. E. Atkinson, A.R.C.A. (Toronto), and J. Arch Brown (Toronto). All of these have withdrawn from the Ontario Society of Artists, with the exception of Mr. Cruikshank, who retains his honorary membership. The

club will have associated with it a strong group of Montreal painters, and also representative men of London, Glasgow, and New York, and works by certain Canadian artists not members of the club will be invited. The first exhibition will be held towards the end of November. The object of the organisation is by exhibiting annually a good selection of pictures to give a clearer idea of the progress of Canadian art than is possible in the more heterogeneous exhibitions.

## A NOTE ON THE WATER-COLOUR SKETCHES OF ALFRED WATERHOUSE, R.A.

THE name of Alfred Waterhouse will live long in the history of English architecture, for his professional career, which terminated about three years before his death in 1905, was crowded with masterly achievements which definitely assure to him a position among the foremost architects of the nineteenth century. It would be tedious to enumerate all the monumental buildings which have come into existence as the fruit of his fertile genius. Manchester, where he commenced practise in 1853; Liverpool, where he was born twenty-three years before (his family, however,



"SANTA MARIA DEGLI ANGELI, ROME." FROM THE WATER-COLOUR SKETCH BY ALFRED WATERHOUSE, R.A.





"INTERIOR OF CATHEDRAL, SAN REMO." FROM THE WATER-COLOUR SKETCH BY ALFRED WATERHOUSE, R.A.



## Alexandre Struys

appears to have been long settled in Yorkshire previously); and London, whither he transferred his practice in 1865; these and many other towns and places all possess structures which testify to his indefatigable zeal, sound judgment, and resourcefulness in the solution of the problems confronting him. Some of his earlier creations were, it is true, conceived in a style of revived mediævalism which does not commend itself to the younger generation of architects as it did to his contemporaries, but in his later work he showed much greater independence and originality of design and method.

Besides being an architect of unusual calibre, however, Mr. Waterhouse was also gifted in a high degree with those qualities which go to the making of a successful painter.

It is instructive to note that even in boyhood his thoughts turned to painting as a future profession, and it is quite probable that had not the parent art claimed the principal part of his energies during the remainder of his life, he would have earned as much fame as a painter as he did as an architect. Still, in spite of the narrow margin of leisure which his busy career left him, he found time to pursue the object of his early love, and whenever opportunities presented themselves devoted himself ardently to landscape painting in oils and water-colours. Some of these landscapes made their appearance in public from time to time at various exhibitions, and at the Royal Academy in the water-colour room; but the number of works thus exhibited were few compared with the entire number he executed. The three examples now reproduced have been selected from a large accumulation of sketches made in water-colour at various times

and places throughout a period of about twenty years and may be taken as fairly representative of his work in that medium.

### ALEXANDRE STRUYS, A BELGIAN PAINTER. BY FERNAND KHNOPFF.

THOSE who delight in classification might find some interest in determining on the one hand the different kinds of works of art that have achieved success, and on the other the different kinds of success achieved by works of art. They would soon become aware that there are what may be called national successes, due to the local influence, more or less political in character of interested



"LOCARNO"

BY A. WATERHOUSE, R.A.

## Alexandre Struys

persons or of narrow coteries; international successes, due to more or less diplomatic relations, and to a subservient consideration for foreign fashions in art; and lastly there is success (the rarest kind of all) due to the intrinsic merits of the work itself.

It is a success of this last description that Alexandre Struys's latest works have achieved. It is seldom nowadays, in fact, that one finds painting which so completely expresses the entire individuality of an artist. Struys's individuality only came to the surface after long and painful hesitation, after numerous and grievous misconceptions; but from that very circumstance has resulted his strong and definite sincerity, which touches the heart deeply, leaving a permanent impression.

Alexandre Théodore Honoré Struys was born at Berchem, near Antwerp, on January 24, 1852. His grandfather had been an artist; his father, a native of Gulenborg, in Holland, was a notable painter on glass, and had come to finish his artistic education at the Academy of Antwerp. When he returned to his own country he sent his son Alexandre to the communal school at Dordrecht, where his master soon noticed his astonishing talent for drawing. The parents had no desire to thwart this evident vocation; and thus it came about that at the age of six Alexandre Struys was already regularly attending the drawing classes at the Academy of Dordrecht. This course of instruction was not, however, of long duration; he subsequently entered the studio of the painter Canta, at Rotterdam, as a pupil, and also—as was still the custom—in the capacity of general help. But neither did this phase last long: the glass-painter went to live in Antwerp again, and sent his twelve-year-old son to the Academy of Fine Arts, which was then directed by N. de Keyser, and had for its principals Professors Beaufaux and Van Leries, painters of the most official type.

The academic successes of Alexandre Struys were not extraordinary; but he worked with commendable diligence under the direction of his masters from 1866 to 1871.

Just at this time Jan van Beers, the wayward painter of ultra-Parisian whimsicalities, and J. Lambeaux, the powerful sculptor of Flemish *grossièretés*, simultaneously terminated their studies at the Antwerp Academy. Jan van Beers was already attracting attention by his exuberant independence of spirit and by eccentricities that had become notorious. He made great friends with Struys, whom he persuaded to join him in a studio he had taken in the heart of Antwerp.

In 1871, while still attending the higher classes at the Academy, Struys had exhibited *A Young Girl returning from School* in the Salon at Ghent; in Jan van Beers' studio he painted a series of humorous pictures, facile and ordinary in character, which obtained no greater success with the public than did the extravagances which his friend invented in order to attract the notice of buyers.



“ L'ENFANT MALADE ”

BY A. STRUYS





“PEUT-ÊTRE?”  
BY A. STRUYS

Certainly "things were going badly," as the saying is.

"It was at this juncture," writes M. E. de Taeye, in "Les Artistes Belges Contemporains," "that Struys proposed to Van Beers to set out for London, after having completed a series of pictures which would be certain, in that great cosmopolitan city, to transmute themselves into a respectable number of pounds sterling!

"Unfortunately, 'Bohemia' proposes and reality disposes. Doubtless the two friends were noticed in London, where their big hats, *à la* Rubens, and their wide cloaks flapping in the wind made some sensation; but in spite of that the picture-dealers to whom they addressed themselves did not manage to sell their famous works. The situation of the good citizens of Antwerp became critical when their funds, slender enough at the outset, were reduced to a few silver coins. They thought of returning to their own country; but how was that plan to be brought off?

"They now set to work simultaneously, one starting from the right and the other from the left, on a colossal canvas representing a magnificent view in Switzerland. Somebody had told them that the English public liked this hackneyed style of picture, and they had gone off instantly to a photograph shop to choose their 'site'! The work progressed swimmingly, and the two friends had every reason to feel satisfied. They had hashed up a splendid Swiss landscape; no doubt somewhat flattered; exaggerated in colour, perhaps; but gorgeous to behold. Nothing was omitted: neither classic mountains, nor beautiful sky, nor limpid little lakes! Having both signed this *chef-d'œuvre* the two friends repaired to their picture-dealer, who congratulated them, and offered them £30 on the spot! Can you doubt that the offer was eagerly accepted? At last they had money! At last they could think of leaving England!

"Once back in their own studio, "Sander" and "Jan"

each began an important work; and while the future painter of *The Siren* was finishing his *Fiat Lux*, a big symbolical representation of Christ, Struys for his part was giving the final touches to his *Perhaps?*—a poor violinist in his garret, for whom Van Beers himself had served as model."

This picture, exhibited in 1873, was very favourably noticed. There was, indeed, more than mere promise in the work; the figure of the poor violinist, tormented with thoughts of his future, was masterly in treatment. This was Struys's real *début*, and henceforth he was classed among the young Antwerp painters "of whom great things were to be expected."

A quarrel finally separated Struys and Van Beers; for some time, however, this separation had been foreseen, the natures of the two men being too different for perfect sympathy to exist between them.



"LE GAGNE-PAIN"

BY A. STRUYS

## Alexandre Struys



“LE MOIS DE MARIE”

BY A. STRUYS

Struys now went to live with the painter H. Bource, whom he had known for a long time. The mournful sentimentality of this artist consoled better with Struys's native melancholy than had the fantastic extravagance of his former companion.

He next painted a picture, old-fashioned and romantic in character, entitled *The Two Victims* (now in the Dordrecht Museum), representing a deserted mother with her child fleeing from misery. His next work, *An Eater of Mussels*, a broadly-executed painting, showed considerable progress.

Struys's real celebrity dates from 1876. An uncle of the painter had

been persuaded by the Jesuits to make over his property to them. The artist saw the possibilities of such a subject, and painted his *Roofvogels* (Birds of Prey), two Jesuits forcing a dying man to make his will. The effect made by this picture was enhanced by the fact that political strife between Liberals and Clericals was then running very high in Belgium. The work in itself was remarkable, and was exhibited everywhere—in Germany and in England; but for political reasons it could not be admitted to the Paris Exhibition of 1878, the Belgian committee of selection refusing it even in Brussels, “because” (wrote Prince Caraman-Chimay, president of the committee, to the artist) “the subject was calculated to offend the susceptibilities of the general public.”

The picture's success was immense, and gained for its author not only European renown, but also an unexpected piece of good fortune. The Director of the Academy at Weimar offered the young Belgian painter of



“LA VISITE AU MALADE”

BY A. STRUYS



“LA CONFIANCE EN DIEU”

BY A. STRUYS

he decided to return to Belgium, either to Antwerp or to Brussels. In 1884 we find him at Malines, looking for some peaceful corner not too far from Brussels and Antwerp, wherein he might select a definite place of abode for the future. But at this time he was in a very dejected state, feeling himself gone astray and enfeebled, and he only perforce listened to the advice of J. Lambeaux, whom he had met again in Brussels. An attempt at *peinture claire*, made in accordance with this advice, was the occasion of some ill-natured criticism. Raging internally, Struys thereupon shut himself up at Malines, refusing to see anyone, in order that in silence and solitude he might slowly recover his damaged individuality—a noble effort which eventually gave us works that are deeply touching in their strong and genuine feeling: *Death* (1886), *The Breadwinner* (1887), *The Sick Child* (1888), *Comforting the Afflicted* (1889), *The Month of Mary* (1890), *Trust in God* (1891), *Despair* (1897), *The Lacemaker of Malines* (1900).

twenty-three the professorship which had been left vacant by the departure of Charles Verlat.

Struys accepted this flattering proposal, and remained at Weimar until 1883. But during these six years, spent in a too solemn and too artificial German *milieu*, the pleasures of society and successes at Court once more weakened and perverted his true individuality. The artist suspected this vaguely himself, and was convinced of the truth after some cruel disillusionments in connection with certain pictures painted at this time: *Alpha and Omega*, *The Death of Luther*, and *Christian II*.

Towards the end of 1882 Struys quitted Weimar and went to the Hague; but subsequently

“And here,” writes M. J. du Jardin, in his “Art Flamand,” “we have the work of Alexandre Struys.



“DÉSÉSPÉRÉ”

BY A. STRUYS

## The Norman Chapel Buildings at Broad Campden



NORMAN CHAPEL, BROAD CAMPDEN, GLOS. : ENTRANCE GATES

C. R. ASHBEE, ARCHITECT

He aspires to the portrayal of suffering—the suffering of the poor, for whom he has a tender compassion: he shows them in the midst of their hard life, which haunts him continually. He points out to the priests—the comforters of the afflicted—their duties towards the poor and wretched, who are as lovable as the rich, or more so. And, besides a very precise conception of his task, he possesses a keen desire for truthfulness in the setting of his subjects, for suitable accessories and models: so much so, that he frequently takes his model to the scene he has selected; and when several persons are to figure together on his canvas, he makes the various models pose at the same time. Such anxiety for realistic correctness, therefore, gives this master a very distinct individuality. No; his style does not bear any resemblance to that of his compeers, either in the present or in the past, who have chosen to recount the miseries of Fortune's disinherited. He has, indeed, been compared to Charles Degroux more especially, and to Constantin Meunier, painters of this type. But for anyone who notes the differences of ideal existent among artists (differences of ideal that are sometimes very

slight in the main), there are many characteristic shades of distinction between their art and his. These shades of distinction may be very correctly determined thus: Degroux and Meunier leave more room for the imagination in their works than does Struys in his; and this particular fact, I repeat, justifies us in asserting that the latter is endowed with a very definite individuality, and that there is no reason to confound his canvases—crying vengeance as they do (whether he intends it so or not) upon social iniquities—with the canvases of any other artist. F. K.

### THE "NORMAN CHAPEL" BUILDINGS AT BROAD CAMP- DEN, IN GLOUCESTERSHIRE. BY C. R. ASHBEE, ARCHITECT.

A SHORT account, together with the series of drawings prepared by Mr. P. A. Mairet, may not be out of place upon what is a unique building and in its way one of the most interesting in England.

It consists of old and modern work, and I have tried during the two years that I have been engaged

## *The Norman Chapel Buildings at Broad Campden*

upon it, to scrupulously conserve the former while adapting it to modern needs, and to bring the latter into harmony with it without in any way working to a period or falsifying history—the old work is old and the new new.

The history of the old work, as far as it is ascertainable, is as follows. An early Norman church, possibly of the time of Harold, who held the manor and from whom it passed to Hugh Lupus, forms the nucleus of the building. From this it gets its local traditional name, "the Norman Chapel." Of this nucleus there remains the south door. (See illustrations on pp. 290, 291), the north or "Devil's Door," an exceedingly interesting chancel arch, and a large part of the masonry in the lower part of the main wing. There is then a curious, presumably fourteenth-century, doorway (see right-hand illustration on p. 291 and left-hand illustration on p. 295) in a portion of the building that is of later date, but the most interesting in the whole is the superb fourteenth-century room (see p. 291) which I have reconstructed as a library, in the upper portion of the original Norman church. It is evident that there has been a pre-reformation change from ecclesiastical to domestic purposes, for the chancel arch was cut across horizontally by a fourteenth-century floor, and some traceried windows and a fireplace were built into the nave of the Norman church. I know of no other case in England where an early church has been thus beautifully desecrated and turned to secular use in pre-reformation times. My own theory as to this, which it would, however, take me too long here to elaborate, is that the whole population, priest and people together, were wiped out at the time of the Black Death, and that some years later when the fine new church at Chipping Campden was built a mile or so away and the Flemish wool merchants settled there with newer hopes and better prospects, the old Norman church, which by tradition is still called the "mother church" of Campden,

became derelict and was converted to secular use. Reference to the top drawing on p. 292 will show the splendid construction of the fourteenth-century ceiling. The screen at the end of the room probably represents the remains of a half-timber partition, but as the whole of the upper part of that end of the building had fallen it is impossible to determine its exact purpose.

The drawing on p. 295 shows the curious stone staircase which led up to the library. The oaken banisters, and also the oaken door—which I have studded with ebony and mother-of-pearl—leading into what is now the dining-room, are new.

Two drawings, one on the bottom of p. 292 and the other on the following page, show from different points the dining-room, which is reached through this door. Half of this room is old, but the rest is completely new, for two of the walls



NORMAN CHAPEL, BROAD CAMPDEN : THE FLAGGED TERRACE  
RESTORATION AND ADDITIONS BY C. R. ASHBEE, ARCHITECT

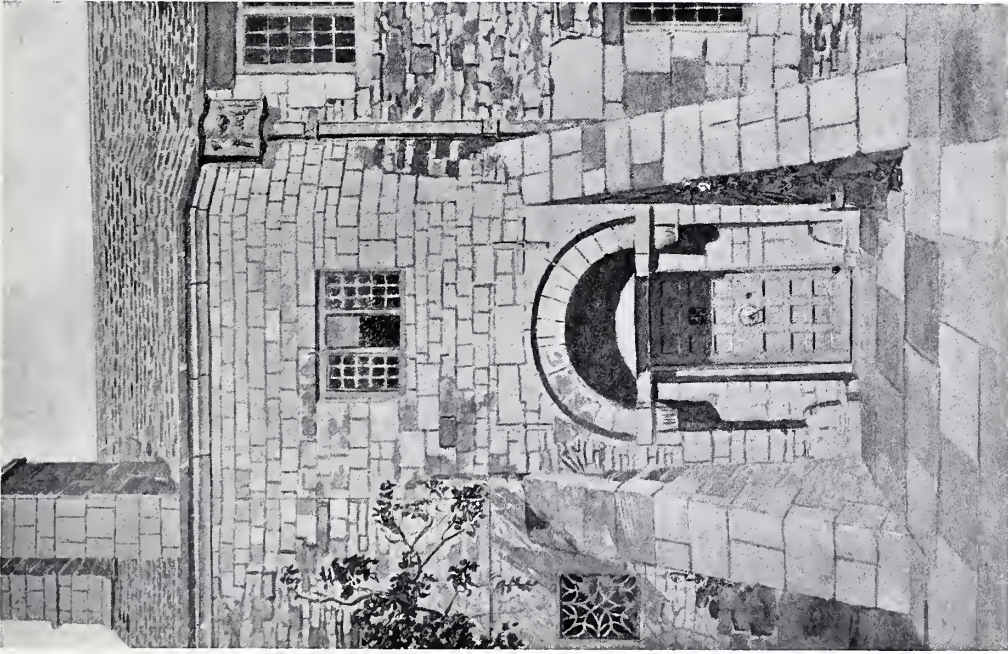

NORMAN CHAPEL, BROAD CAMPDEN : THE SOUTH DOOR  
RESTORATION BY C. R. ASHBEE, ARCHITECT

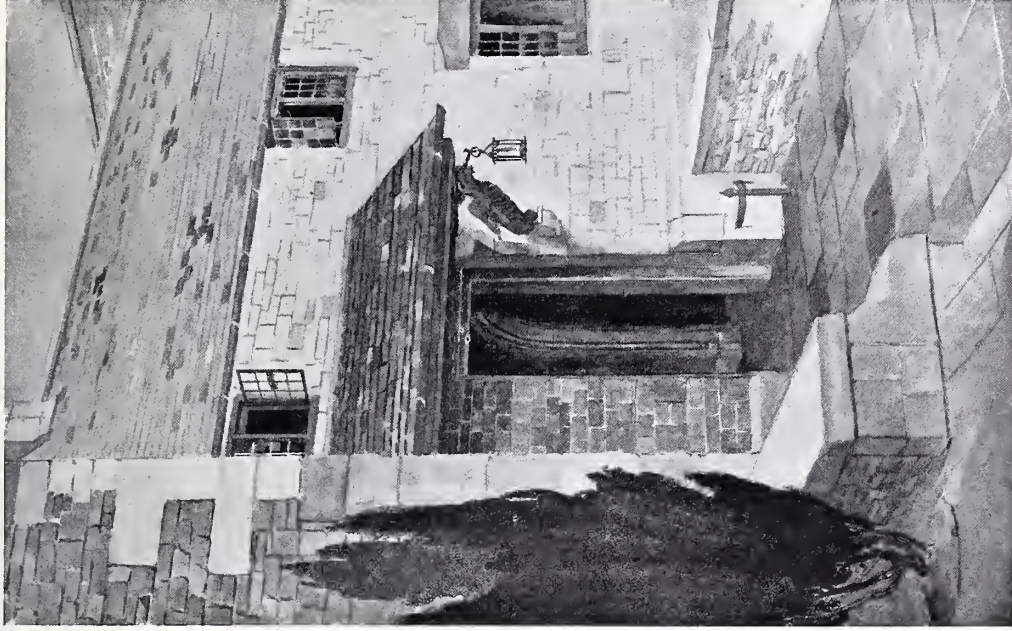

NORMAN CHAPEL, BROAD CAMPDEN : THE PORCH  
RESTORATION AND NEW WORK BY C. R. ASHBEE, ARCHITECT

## The Norman Chapel Buildings at Broad Campden

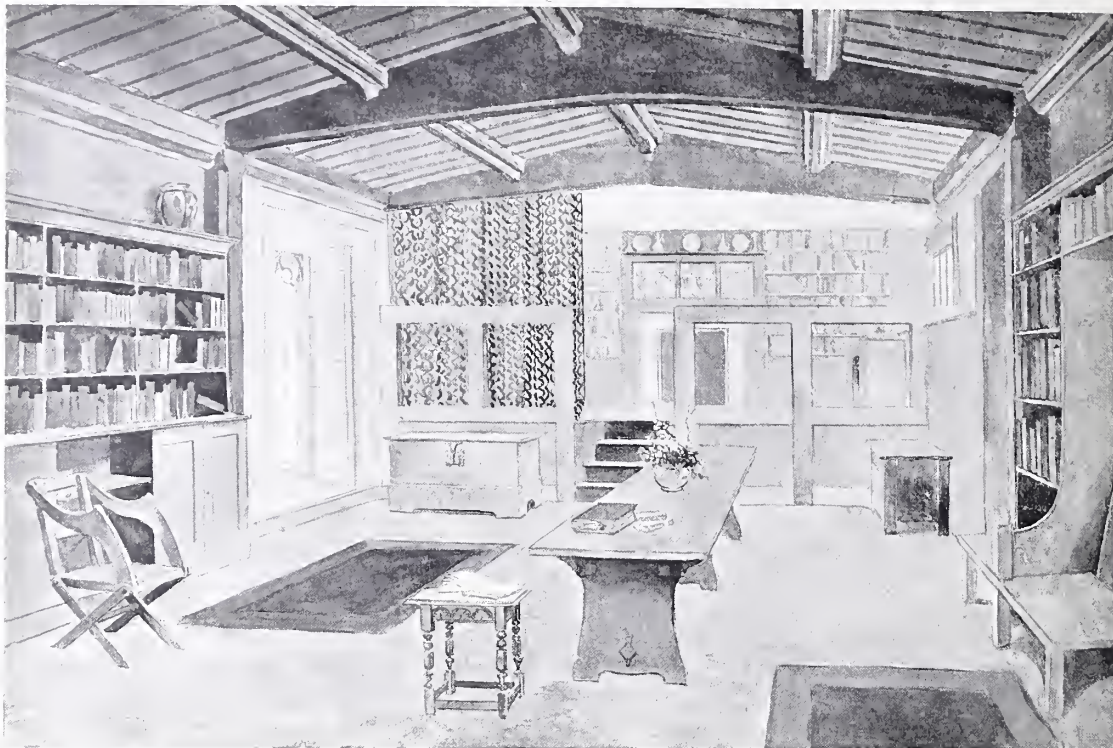

NORMAN CHAPEL: THE LIBRARY

RESTORATION AND RECONSTRUCTION BY C. R. ASHBEЕ, ARCHITECT

and part of the floor had fallen. I managed, however, to save a good many of the old timbers, as also the fireplaces. The south-east end looking on to the terrace (see p. 290), is new;

it comprises a large bow built in oak and rough-cast and in the traditional Gloucestershire manner. This was essential, to adapt the room to modern requirements of sun and air.

When I first took the building in hand this was the only room that had an occupant—a fine Gloucestershire sow with her litter, whom she was bringing up with great care under some fragments of fourteenth-century stone carving.

Above the dining-room is a very beautiful fourteenth-century bedroom (see illustration, p. 293). The roof was at one time a simple king-post structure, but it had been neglected, and the centuries of thatching through which the rain had now penetrated had ruined the work for carrying purposes. It seemed a pity, however, to gut this, so I built a

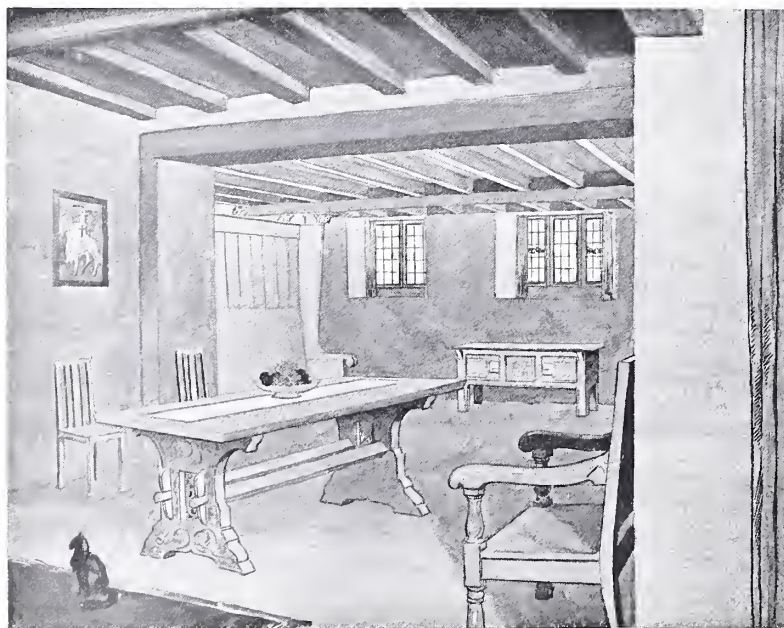

NORMAN CHAPEL: DINING ROOM

RESTORATION AND NEW WORK BY C. R. ASHBEЕ, ARCHITECT



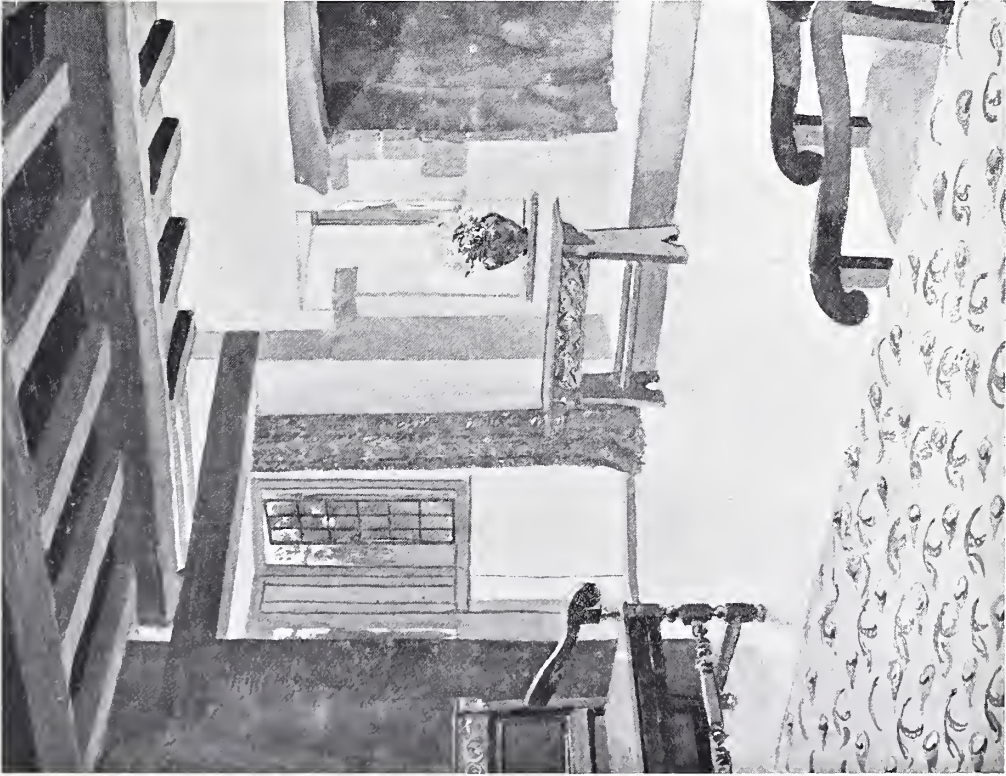

NORMAN CHAPEL, BROAD CAMPDEN : BAY WINDOW IN DINING ROOM  
RESTORATION AND ADDITIONS BY C. R. ASHBEE, ARCHITECT

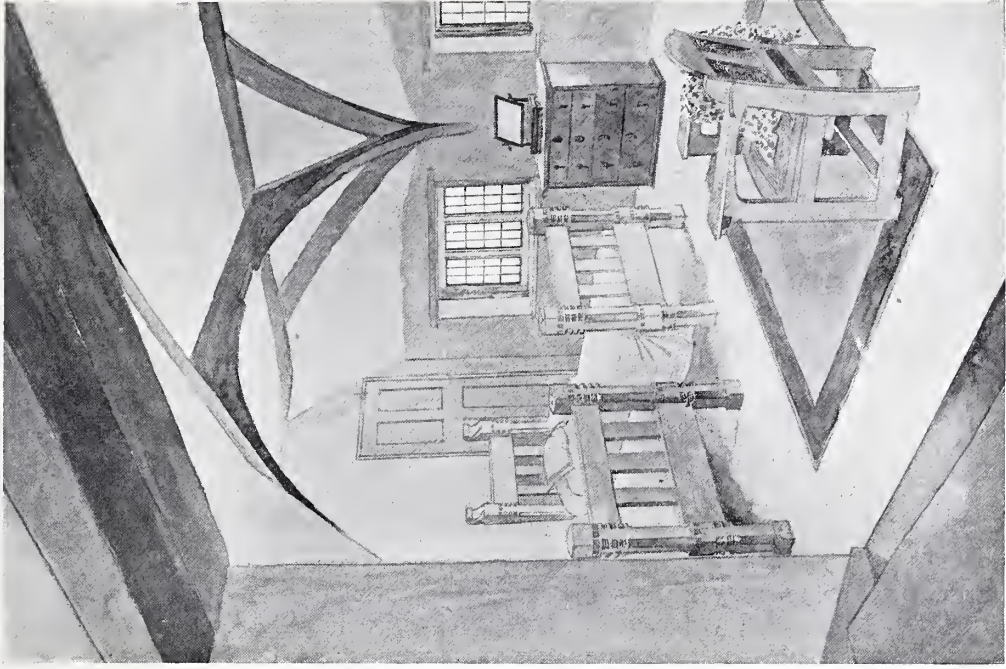

NORMAN CHAPEL, BROAD CAMPDEN : A BEDROOM  
RESTORATION AND RECONSTRUCTION BY C. R. ASHBEE, ARCHITECT

## *The Norman Chapel Buildings at Broad Campden*

new roof on top (see pp. 290 and 291, No. 2), and hung the old roof, shown on p. 293 (right-hand illustration), on to the new.

Passing now to the new work. This is best shown in the illustrations on pp. 289, 294, and 295. Of these the first shows the approach from the road, the new gable appearing over a yew hedge, which, it should be added, has not yet reached the desired height and form, but with care and time (perhaps fifteen years !) will grow into the hoped-for design. The next, which is also yet in embryo, shows the flagged pavement that leads to the house, leaving the new wing, in which are kitchens and offices, on the right. New, also, is the little stone porch where Mr. W. Hart has carved for me a fine oaken corbel—a dragon carrying a lantern from its iron tongue, so that the visitor on winter nights shall not inhospitably stumble.

The house itself stands in about two acres of garden and orchard, and thus there has been scope for the forming of a rather beautiful garden, upon which we are still at work. The drawing reproduced on p. 295 shows this looking up from the

rock garden past the pergola, rose garden, and enclosed kitchen garden beyond, while the new wing is seen above the trees by the tennis lawn.

The bulk of the work in this building was done for me by the Guild of Handicraft, and I think Mr. J. W. Pymont, the foreman, is to be much commended for the thoughtful and sympathetic manner in which he has, over a period of eighteen months, handled the various details and problems of the work ; he is responsible not only for most of the structure of the building, but also for the furniture shown in the drawings, most of which was made in his workshop and in character with the house.

A word should be added about the metal work. This is for the most part beautiful Sinhalese craftsmanship, some of it richly damascened by native workmen. Dr. A. K. Coomaraswamy, for whom I have had the privilege of working, and who now lives in the house, sent this over from Ceylon. He has also added many other splendid and beautiful Oriental treasures, and his collection of Sinhalese arts and crafts, upon a history of which he is at present engaged, is curiously fitted to the



NORMAN CHAPEL: ENTRANCE TO THE HOUSE

NEW WORK AND RESTORATION BY C. R. ASHBEE, ARCHITECT

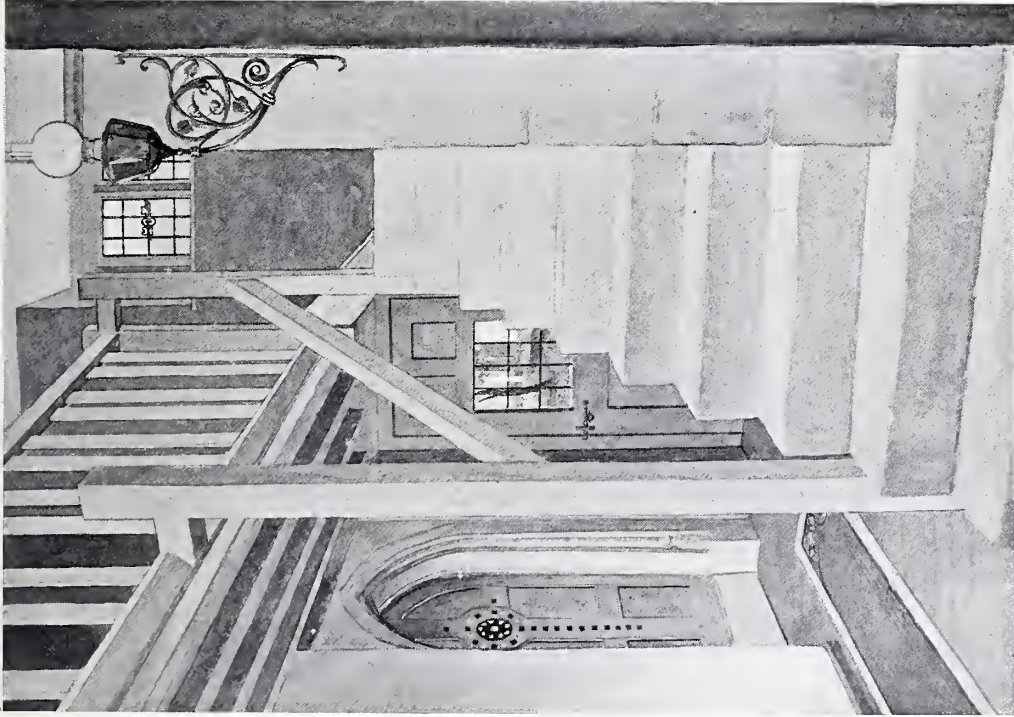

NORMAN CHAPEL, BROAD CAMPDEN : THE STAIRCASE  
RESTORATION AND NEW WORK BY C. R. ASHBEE, ARCHITECT



THE NORMAN CHAPEL GARDEN AT BROAD CAMPDEN  
DESIGNED BY C. R. ASHBEE

character of the building in which it is placed. It is indeed fortunate that the building is owned by one whose fine taste is so sympathetically conservative.

C. R. ASHBEE.

**“THE STUDIO” YEAR-BOOK OF  
DECORATIVE ART, 1908.**

The third number of this Year-Book is now in preparation. As in the second volume, one of the leading features will be a section devoted exclusively to DOMESTIC ARCHITECTURE, and the Editor will be glad to receive drawings or photographs of recent work of this nature, in addition to designs, etc., suitable as illustrations to the various subjects dealt with in the two previous issues. These should reach us not later than October 31st, and bear the name of the designer (and manufacturer, if any), with a short descriptive title of the design.

**T**HE NATIONAL ART COMPE-  
TITION AT  
SOUTH KEN-  
SINGTON, 1907.

THE exhibition at South Kensington of the prize studics in the National Art Competition, although on the whole disappointing, is interesting for the number of excuted designs that it contains in almost every department of work. A dozen years ago it was a rare thing at the National Art Competition exhibitions to see a piece of craftsmanship hung side by side with the original design, and few students would then have dreamed of attempting the realization of the ambitious works in enamel, metals, ivory and precious stones that arc shown to-day. Perhaps it was as well, for many of the designs of that period that looked well enough on paper, neatly drawn and coloured, were in practice unworkable, and complaints were constant from those examiners who were possessed of technical

knowledge that the ideas the students had evolved with such care and elaboration were impossible of execution within the limitations of the chosen material. In the eighties—and earlier—the tendency of nearly all the Government schools was to develop the artist (using the word in its conventional sense) at the expense of the designer, and the National Art Competition exhibitions were interesting at that time rather for the studies shown in painting, drawing, and modelling, than for evidences of the application of those branches of the arts to design and decoration. It was a wrong tendency, of course, as the schools produced young painters and sculptors in the place of designers and craftsmen, but the tendency had its good side. Through it was maintained a fairly high standard of work from the living model, and the drawing and painting from the life which must always be the backbone of the higher classes of design was generally speaking of far better quality

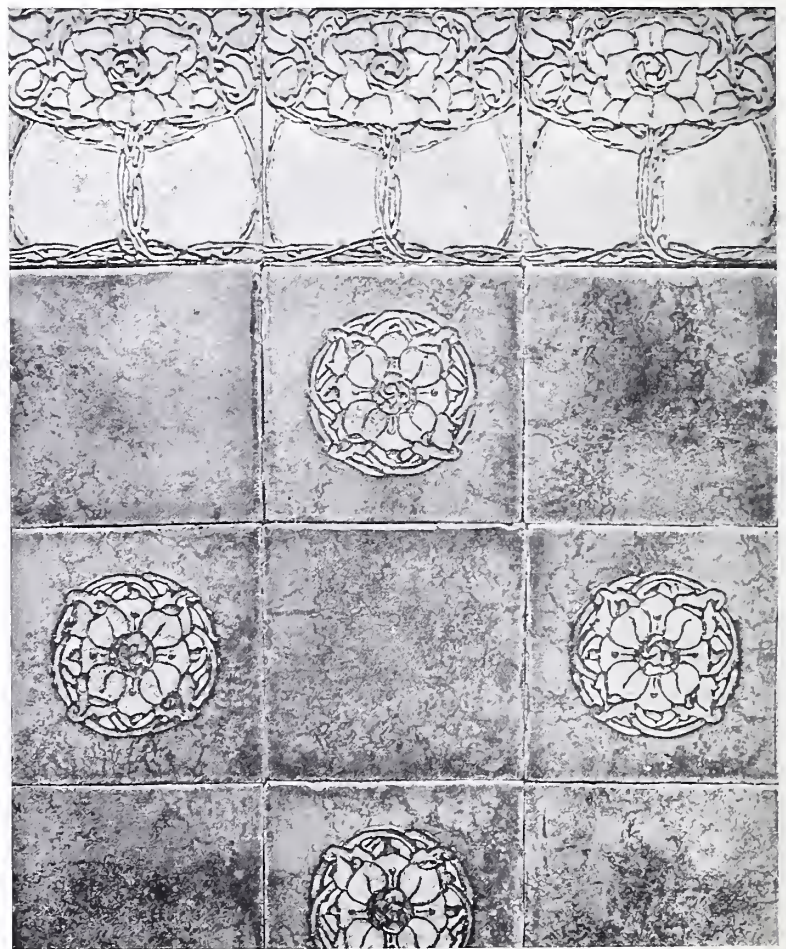

MAJOLICA TILES

BY ALBERT MOUNTFORD (BURSLEM).

## The National Competition, 1907

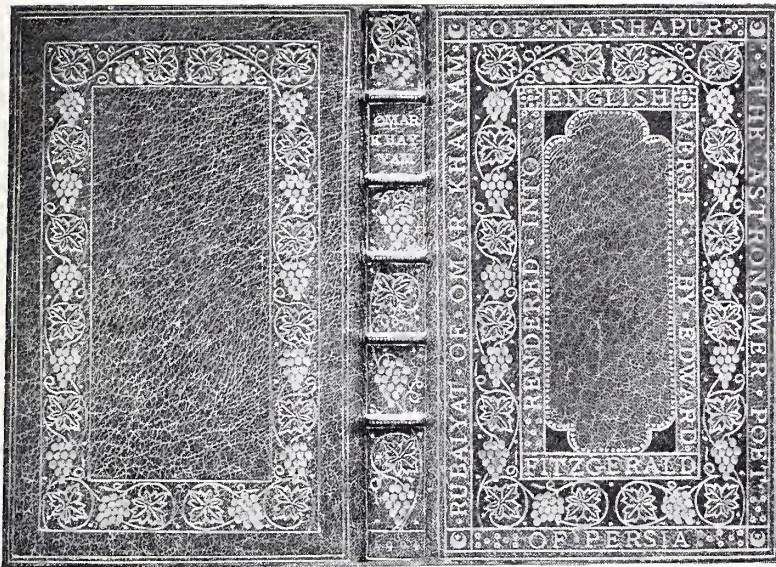

LEATHER BOOK COVER

BY JOHN CHAPPLE (CAMBERWELL)

vailing poverty of ideas. There is little originality, and in design the students seem to be following too closely upon the lines of works that gained awards in preceding exhibitions—a natural tendency, but one that should be discouraged by the teaching staffs of the schools.

However, there are in one department welcome evidences of advancement both in invention and in technical accomplishment. The enamels, good in design and execution last year, are far better this, and beyond all comparison better than those

than it is to-day, when the examiners can find only one study from the nude worthy of a higher award than a bronze medal. The relative weakness of the modern student in this important respect can be sufficiently estimated by looking at the majority of the designs in the present exhibition in which the human figure is prominent.

In the encouragement of the student to execute the work that he has himself designed, the examiners are working on the right lines, but a higher technical standard than that shown in most of the examples at South Kensington should not be impossible of attainment. The executed work from Birmingham is more competent generally than that sent from any other school represented in the exhibition, from which poor and slovenly workmanship is not entirely absent. But this is not the disappointing feature of the National Art Competition of 1907, the real weakness of which lies in the evidence of a pre-

of a few years ago. In 1895 William Morris and his fellow judges deplored the fact that the designs for enamels seemed so poor that there was nothing to notice in them except perhaps that there were indications here and there of some

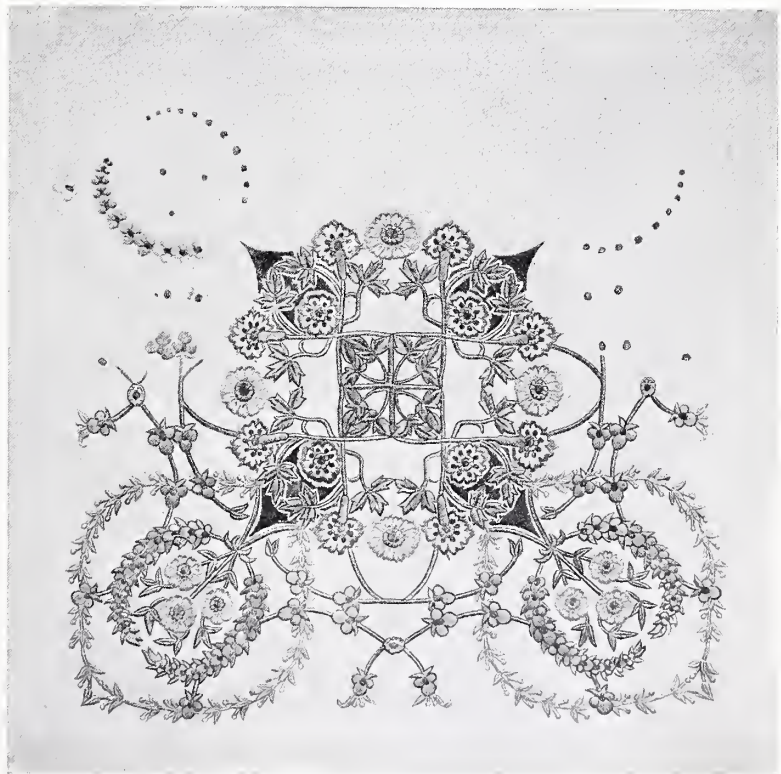

EMBROIDERED TABLE CENTRE

BY CONSTANCE E. NORFOLK (LEEDS)

## The National Competition, 1907

feeling for colour. Morris—a frequent judge in these competitions in bygone years—would, it is safe to say, have found something to admire in the enamels in the present exhibition, although he might not have gone so far as the examiners of 1907 in mentioning the work of a student as “so notable an achievement as to be worthy to be ranked with the best enamels in *grisaille* of any period.” The little cross by Mr. Thomas H. E. Abbott, of the Leeds School of Art, to which the examiners refer, is certainly excellent, but it would have been better, in the interests of the student himself, to have spoken of its merits with more reserve. A noticeable quality of the enamels shown this year is their commendable reticence of colour. Colour in enamels may or may not be capable of making those of oil paint “look like mud,” as Sir Hubert von Herkomer once told the Royal Academy students that it could, but it is easily possible to obtain with it hues of flaring gaudiness, and it is the prevalence of these hues that too often makes objectionable the work of the amateur jeweller who shows his or her work at one or other of the many local arts and crafts exhibitions.

The tendency this year is towards reticence rather than assertiveness of colour, and there is something curiously attractive in the subdued tones of the enamelling, in a severe and somewhat formal design, of the small copper candlesticks shown by Mr. James J. Burke, of Dublin. Different in conception and treatment, but similar in reticence of colour, are the four plaques with little pictures of animals in enamel, contributed by another Dublin student, Mr. J. Ernest Corr. Apart from their qualities as enamels these plaques are notable for the good placing in the pictures of the rhinoceros, lion, dogs, and deer that the artist illustrates. A larger enamelled panel by Miss Geraldine Morris, of Birmingham, illustrates the story told by Malory in the “Morte d’Arthur” of Sir Tristram entreating that the life of his stepmother should be spared, although she had been sentenced to death for trying to poison him. Miss Morris’s panel is a fine piece of rich and lustrous colour, but pictorially it is over-ambitious. The composition is crowded and involved, and the panel, deserving of high praise for its execution and intention, suffers by comparison

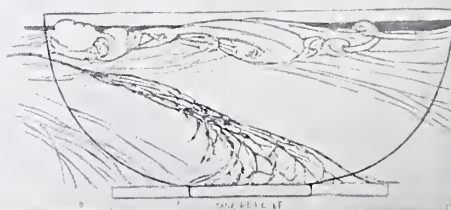
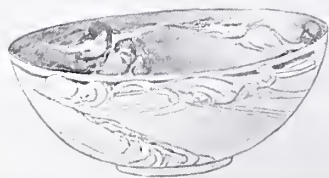

DESIGN FOR A PAINTED BOWL

BY SYBIL TAWSE SUNDERLAND

## The National Competition, 1907



DESIGN FOR A PANEL FOR MURAL DECORATION

BY GWYNEDD HUDSON (BRIGHTON)

with the simplicity and reserve of the Dublin work that is placed beside it. A nice appreciation of colour and harmony is shown by Mr. William T. Blackband in the arrangement of the enamelled leaves, opals, and amethyst, in the circular pendant for which he has been awarded a gold medal.

There is not much ironwork, either designed or executed, at South Kensington, and the few pieces shown are with one exception inconspicuous. Things like handles, hinges, door-plates and keys are well within the powers of the student, and are capable, as a recent exhibition at the Fine Art Society's brought home to us, of high development on artistic lines. The key especially lends itself to fine treatment, but not one is to be found among the executed designs in the National Art Competition Exhibition, and only an insignificant group of door-plates and hinges. The best thing by far among the ironwork is the design by Mr. Albert Halliday of Bradford for a chancel screen. A full sketch of the design is shown accompanied by a panel wrought by the student. The little brazier in wrought iron shown by Mr. Frank Martin, of Birmingham, attracts by its simplicity, but its small scale makes it look like a stand for a flower pot. The electric light lantern in wrought iron by Mr. G. R. Glandfield, of Plymouth, is overloaded with unnecessary ornament.

A tendency to add ornament for ornament's sake and not because it is an essential part of the design is naturally common among the work of students

who have not learnt properly to appreciate the value of simplicity. There are many examples of this failing in the present exhibition, and of that other frequent weakness of the student—the straining after novelty at the expense of fitness and beauty. For example, the examiners in their report welcome the attempt that is being made to produce designs for wicker furniture, and hope to see further efforts in this direction. But in the two or three drawings of wicker furniture that are shown, the student appears only to have aimed at producing something different from instead of better than the articles in everyday use. The wicker chair of commerce is not as a rule ungraceful, and in its commonest form is superior to those seen in the drawings to which the examiners have given a National Book Prize. Again, the examiners welcome “practical efforts in boot and shoe decoration,” and perhaps our footgear does leave something to be desired in beauty and elegance. That the boot—and still more the shoe—can be beautiful we know from those that have come down to us from earlier and possibly more artistic periods, but it is questionable whether the beauties of those examples can be combined with the needs of the twentieth century. In any case, there is nothing except a little more ornamentation in the arrangement of the, stitching to differentiate the “gent's golf or walking boots” and the “ladies' Balmoral shoes,” honoured in the National Art Competition, from the ordinary boot or shoe sold in the

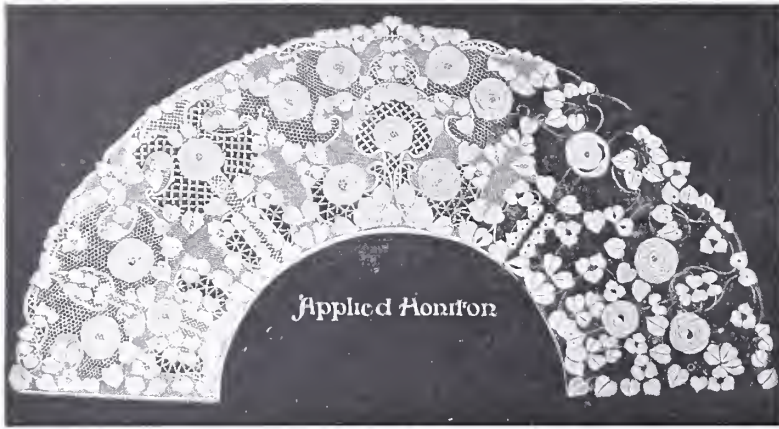

DESIGN FOR A LACE FAN

BY GERTRUDE M. CHAPMAN (DOVER)

ready-made shops, and until something better can be produced it will be as well to exclude such examples from the exhibition. Another unsuccessful attempt to apply art to the common uses of life is the very ordinary design for the decoration of an iced cake, of which there is no need to show a full-sized and coloured model.

Among the modelled designs nothing is better than one for a square carved wooden box by Mr. Charles H. Gait, of Plymouth Technical School. Panels representing the four Seasons adorn the sides of Mr. Gait's box, on the slopes of the lid are the signs of the zodiac, and the top is surmounted by a section of the terrestrial globe. It is a pity that Mr. Gait was unable to show his box in wood as the exhibited work in wood-carving is both poor in quality and moderate in quantity, although the art is more practised now than at any other time in our history. Another box worthy of notice is the jewel casket by Mr. Hubert Martin of Camberwell, in which wood of a subdued colour has been used in combination with silver and turquoises. A word of special commendation is due to the jewel casket of ivory with silver ball feet and silver hasp and corners, the work of Miss Anne G. Stubbs, of Birmingham (Margaret Street) School of Art. Of the designs for work on a larger scale in which metals and other materials are combined, that for a music cabinet by Mr. W. S. Williamson, of Bridgwater (see p. 302) may be mentioned. He shows complete drawings of his cabinet, and one of the doors executed in walnut wood, carved with a simple design based on the bramble rose, slightly inlaid, and with metal fittings. It is interesting to notice that everything in the cabinet, design,

construction, inlay, carving, and metal work are from the hands of the same student.

For beauty of colour, the set of majolica tiles shown by Mr. Albert Mountford of Burslem (see p. 296) is superior to anything of its kind that has been seen for several years in the exhibition of the National Art Competition works. The tiles are of a dull but rich turquoise blue, and every alternate one in the panel exhibited

is decorated with a rosette of a curious pinkish-red which re-appears in the border in a more elaborate form as a conventionalized flower. The tiles have been made as well as designed by Mr. Mountford,



ILLUMINATED TEXT  
FOR THE NURSERY

BY EVA A. BATLEY  
(IPSWICH)



# The Parable of the

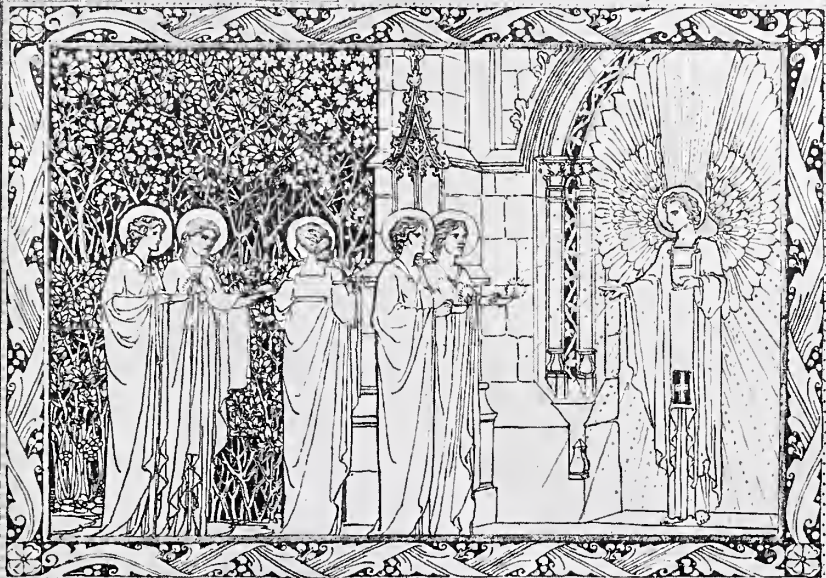

## Ten Virgins

**W**hen shall the Kingdom of Heaven be likened unto ten Virgins which took their lamps and went forth to meet the bridegroom.

And FIVE of them were WISE and FIVE were FOOLISH. They that were foolish took their lamps and took no oil with them.

But the WISE took oil in their vessels with their lamps. While the bridegroom tarried they all slumbered and slept.

And at midnight there was a cry made: Behold, the bridegroom cometh; go ye out to meet him.

Then all those virgins arose and trimmed their lamps.

And the foolish said unto the wise Give us of your oil; for our lamps are gone out. But the wise answered.

Saying not so; lest there be not enough for us and you; but go ye rather to them that sell and buy for yourselves.

And while they went to buy the bridegroom came and they that were ready went in with him to the marriage and the door was shut.

Afterward came also the other Virgins saying LORD LORD open to us.

But he answered and said Verily I say unto you I know you not.

Watch therefore for ye know neither the day nor the hour when the SON of man cometh.

DESIGN FOR AN ILLUMINATED PAGE  
OF A BOOK. BY HUGH HEPBURN

(NEWCASTLE-ON-TYNE, ARMSTRONG COLLEGE)

of whom more should be heard later on. He is only seventeen. The designs for stained glass are fairly good, and the credit for nearly all the best of them belongs to the Birmingham school. Arrangements have been made at one end of the exhibition gallery by which the executed specimens of stained glass can be seen tolerably well, but there is still room in this respect for improvement.

Designs for fans are far below the level of other years, with the single exception of the fan in Honiton lace for which Miss Gertrude M. Chapman, of Dover, receives the well-deserved honour of a gold medal (see p. 300). Miss Chapman's design, founded on the rose and its foliage, is admirable in arrangement, and its scale is well fitted to the size of a small object like a fan. The sketches for the fan-ends in silver and mother-of-pearl, and for the small sticks in mother-of-pearl alone, which accompany the design for the fan and the worked example, are not so good as that for the lace itself. The design for a painted plaque by Miss Gladys Luke of Plymouth Technical School has a border of conventionalized waves and Elizabethan ships which is too good for the portrait of the Virgin Queen that it surrounds. But the border is capital, and there is promise in another design for painted pottery by Miss Sybil Tawse of Sunderland, a bowl the inside of which is decorated with long-haired mermaids with extended arms linked together (see p. 298). The illuminated text for a nursery by Miss Eva A. Batley of Ipswich, with Blake's "Nurse's Song," written and illustrated on a sheet of parchment suspended by a framework of green leather (see p. 300) is quaint and attractive, but it is questionable whether children would appreciate it, and it would probably be somewhat costly to produce. The design by Mr. Hugh Hepburn of Newcastle-on-Tyne for the illuminated page of a book, with gold capitals and lines, and a pen-and-ink picture of the *Parable of the Ten Virgins* (see p. 301) is effective in arrangement. The designs for book illustration by Mr.

Frederic Carter of the Polytechnic (Regent Street) show some invention and a considerable diversity of style ranging from the broadly treated drawings, of which "*A Scientific Examination*" (see p. 303) is a good type, to the Beardsleyesque "*Pierrot Malade*." They are weak in the treatment of some of the details, notably in the drawing of hands, but this is a defect that study and experience should remove.

The weakness of the students' drawing when the figure is treated in design, which was referred to at the commencement of this article, is exemplified in the exhibition by a large design for a decorative panel with classical figures by a lake. The design itself is not altogether bad, but it is one that should not have been attempted by any student unless his knowledge of drawing from the nude was moderately extensive, and the same criticism applies to most of the sketches for figure decoration shown on the same screen. The decorative painting in spirit fresco by Miss Gwynedd Hudson of the Brighton School of Art (see page 299) has some qualities of colour, but it seems impossible that it could look well set in a space on a panelled wall as indicated by the student in the small sketch that



PORTION OF A MUSIC CABINET  
DESIGNED AND EXECUTED BY WM. S. WILLIAMSON (BRIDGWATER)



BOOK ILLUSTRATION: "A SCIENTIFIC EXAMINATION" BY F. CARTER (REGENT ST. POLYTECHNIC)

accompanies her picture. None of the painted or drawn designs in which the figure is introduced is of the same class as the best work of a similar kind shown in the competitions of earlier years, and one frieze in particular is so poor that it should not have been exhibited. Of the studies from the nude figure, those of Mr. W. E. Wigley, of Birmingham, are perhaps the best in the collection. His water-colour study from the nude is better than any of the oils shown, and the drawing for which he has been awarded a bronze medal has an air of refinement that is lacking in the works that surround it. There are sheets of creditable time studies from the nude

from Chelsea and Leicester (the Newarke), and the head in oils of a little red-haired girl by Mr. R. J. Stubington, of Birmingham, is carefully drawn and tenderly painted. In the class of modelling from the life the best work is seen in the excellent torso of a man by Miss Constance Skinner of the Hammersmith School of Art. W. T. WHITLEY.

NATIONAL COMPETITION, 1908.—The Council of the Society of Arts announce that they are prepared to offer, under the terms of the Mulready Trust, a gold medal or a prize of £20 for competition amongst students of the Schools of Art of the United Kingdom, at the Annual National Competition to be held in 1908. The prize is offered to the student who obtains the highest awards in the following subjects:—(a) A finished drawing of imperial size from the nude living model. (b) A set of time studies on a small scale, from the nude living model, executed in a short time, of varied shortly sustained poses (mounted on not more than two imperial size mounts). (c) A set of studies of hands and feet from the living model (mounted on not more than two imperial size mounts). (d) Drawing from the life, including memory life drawing done at the examination in May, 1908. No student will be eligible for the award who does not pass in drawing from the life (d), and who does not obtain an award for (a) the finished drawing from the nude living model. The other two subjects are optional. The works must have been executed between April 1st, 1907, and March 31st, 1908. The recipient of a prize awarded under this trust in 1892, 1893, 1896 or 1903, cannot compete again. The drawings, etc., are to be submitted, with other school works, in the usual manner to



PORTION OF ALTAR RAIL IN REPOUSSÉ BRASS AND OAK, FOR ST. LUKE'S CHURCH, SEVENOAKS  
DESIGNED BY J. T. LEE, F.R.I.B.A.  
(See *London Studio Talk.*)

the Board of Education, South Kensington, in April, 1908. Each competing drawing must be marked "In competition for the Mulready Prize," besides being labelled as required by the Board of Education.

### STUDIO-TALK

(From our Own Correspondents)

**L**ONDON.—We illustrate on the previous page part of an altar rail designed by Mr. John T. Lee, F.R.I.B.A., for St. Luke's Church, Sevenoaks. Both the design and the material used for the rail, the cill, and the uprights, are appropriately derived from the oak tree, while the *repoussé* brass work adds to the effectiveness of the whole.

That law is not always identical with justice was conspicuously shown by the case of the United Arts Club which came before the courts at the end of July. The club had been regularly paying rent for its quarters in King Street, St. James's, to its immediate landlords, Willis's Restaurant Company, but this company having fallen into arrears to the extent of some £2,000 for rent due to the superior landlords, Messrs. Robinson and Fisher, the well-known firm of auctioneers, the latter exercised the right given them by the law and distrained on the whole of the premises leased to the Restaurant Company, including the portion sublet to the United Arts Club, and including also the pictures that happened to be on the premises at the time (the club has been holding quarterly exhibitions of pictures, and apparently there were a large number of works on show at the time the superior landlords distrained). The club at once applied to the Court of Chancery to interdict the sale of these pictures, but Mr. Justice Neville, who heard the case, while expressing himself very strongly as to the "monstrous state of the law," was unable to grant the injunction sought. We understand that the club has decided to appeal from the Judge's decision, but the appeal cannot be heard until the end of October when the courts resume their sittings; and in the meantime the pictures cannot be removed from the premises. Attention was called to the case in the House of Commons last month, but the Attorney-General held out no hope of early legislation to remedy the unjust state of the law disclosed by it.

But a little while since the privileges of our exhibitions were extended only to drawings which had the appearance of what was termed "finish," the methods by which such appearance was obtained

being a secondary consideration. There are quarters now, however, in which encouragement is given to other merits, such as sensibility of line. Independent existence as an art is thus almost again restored to drawing, after a period of eclipse. The studies by the Hon. Neville Lytton, Mr. William Orpen and Mr. Muirhead Bone, which we reproduce, are interesting as the work of artists concerned in this renaissance. In the case of Mr. Muirhead Bone we illustrate some of his slighter efforts, for in his artistic shorthand he is as happy as in his finished drawings, being always at his best in work done under the direct stimulus of the movement of life. It is by such notes as these, which overflow his sketch-book, that we are enabled to estimate the resources of



FROM A DRAWING IN RED CHALK  
BY THE HON. NEVILLE LYTTON



FROM A STUDY IN RED CHALK  
BY THE HON. NEVILLE LYTTON



LEAD PENCIL SKETCH  
BY W. ORPEN



SKETCH IN LEAD PENCIL

BY MUIRHEAD BONE

his art, and the richness of the vein which his sympathy has discovered in the everyday aspects of the streets. Perhaps, though, it is a hint that we should not take his artistic persiflage too seriously that in one little sketch the name on a brewer's dray has been spelt with so much delibera-

tion. A more serious phase of his art was seen in a drawing of St. James's Hall which he made when that building was in course of demolition, and which was a notable feature at a recent exhibition of the New English Art Club.

The exhibition of Mr. Paul Maitland's paintings at the Paterson Gallery, Bond Street, showed that painter's always interesting work to advantage. His only rival in a certain delicate manipulation of the oil medium and refinement of view was his pupil, the late Mr. W. Osborn, of whose work some specimens were also to be seen on this occasion. Perhaps the latter's was the purer sense of colour, though in the pictures of both of these

artists a tendency to gloom is noticeable, which Whistler, evidently their master, proved was not the necessary adjunct of low-toned painting.

We reproduce a pastel and a water-colour by Mrs. Mabelle Unwin, whose exhibits at the Society



SKETCH IN LEAD PENCIL

BY MUIRHEAD BONE



"MARCH WINDS" (PASTEL)

BY F. MABELIE UNWIN

(See also page 313)

of childhood is nearly always the motive of her brush. Of her success in this the pastel *March Winds*, here reproduced, speaks for itself. Her work has many pleasant qualities in colour and design which heighten the attractiveness of her always well-chosen subjects.

In his clever water-colours of London subjects (of which an example was given in our February number) Mr. W. Walcot is greatly assisted by the knowledge which his training as an architect has given him. No doubt to qualities thus imparted to his work is largely due his success in giving an illusion of moving traffic against a background of London architecture. His drawings catch more than a little of that spirit of haste and bustle which is the pervading one in the London streets.

Without displaying any features of exceptional interest the exhibition of works by the students of the Royal College of Art, held last month in a building behind the

of Women Artists and elsewhere we have before this had occasion to notice. To express the charm National History Museum, South Kensington, proved in some respects more worthy of attention



"THE HORSE GUARDS, WHITEHALL"

(In the possession of F. Garrett, Esq.)

BY W. WALCOT





"CHAPEL OF HENRY VII., WESTMINSTER ABBEY." FROM THE WATER-COLOUR BY W. WALCOT.  
*(In the possession of the Rev. H. A. Stanton.)*





“PICCADILLY”

*(In the possession of F. Garrett, Esq.)*

BY W. WALCOT



“KINGSWAY”

BY W. WALCOT



FROM A PHOTOGRAPH  
BY S. ELWIN NEAME

than the National Competitions Exhibition, which took place at the same time in the Indian Section of the Victoria and Albert Museum, and fully dealt with elsewhere in this number. Amongst the decorative paintings exhibited by the students of the Royal College were several compositions which showed originality in conception and poetic imaginativeness. Full scope being given to the individuality of the young artist, it is not surprising to find some of the designs bordering on the grotesque. Nevertheless the freedom from convention which characterised the collection was, on the whole, stimulating and hopeful. Of the larger drawings *The Gates of Life*, by Mr. T. Lewis, showed undoubted merit both in the conception and execution of a rather



"THE STORY BOOK"

(See also p. 308)

BY F. MABELLE UNWIN

ambitious composition. Influenced to some extent by the creations of Puvis de Chavannes, the artist has endeavoured, and not altogether unsuccessfully, to introduce a dramatic note, without detracting from the decorative qualities of the whole. *Humanity Unveiling Nature*, by Miss Amy K. Browning, was another ambitious work, but lacking the higher decorative qualities of the design just referred to. Mr. A. Mackinder's *Henry III. granting Charter to Newcastle to sink Coal Shafts*, displayed sound draughtsmanship and a right feeling for the balance of the composition; while his *Finding of Dechtire* and *Setanta earns the name of Cuchulain* were amongst the best of the smaller designs.



PHOTOGRAPHIC STUDY

BY S. ELWIN NEAME

We here reproduce two photographic studies of drapery by Mr. S. Elwin Neame, who has devoted much thought and experiment to the subject. The disposition of drapery upon the figure has always

tested the degree of taste possessed by artists before ever pencil is put to paper, when selection and treatment come into play. In the case of photography everything depends upon the first arrangement, which calls for unflinching taste and a knowledge of tradition.

We reproduce as a supplement a water-colour drawing of the famous *Bridge of Sighs* in Venice, by the late C. E. Holloway, of whose works an exhibition was recently held at the Baillie Galleries. The name of Whistler is associated with that of Holloway, whose neglected art he befriended. There can be little doubt that in his own art Whistler owed something to Holloway. They were drawn to similar subjects, such as the River Thames and Venice, and Holloway's more prosaic brush perhaps suggested to Whistler aspects of both which in his own art he rendered with such beauty.

The exhibitions held in London during the months of August and September are usually of such moderate interest that the collection of paintings and water-colours now on view at the Leicester



MEDALLION PORTRAIT OF KING EDWARD VII.  
FOR MONUMENT AT MARIENBAD  
BY GUSTAV GURSCHNER



MEDALLION PORTRAIT OF KAISER FRANZ JOSEF  
FOR MONUMENT AT MARIENBAD  
BY GUSTAV GURSCHNER

Galleries should prove a boon to the many visitors who only come to the Metropolis during the holiday season. Here will be found a limited number of pictures by well-known artists, several of which will well repay careful study. The water-colours are the more interesting, comprising as they do drawings by such acknowledged masters as Turner, David Cox, Peter de Wint, George Barret, Samuel Prout, David Roberts, James Holland, William Hunt, J. S. Cotman, Tom Collier, and E. M. Wimperis, together with an impressive piece by Mr. Arthur Severn, called *Sunrise at Sea*, in which the general tonality and atmospheric qualities are particularly fine. Amongst the paintings *The Waterfall*, by Mr. Wilson Steer, shows dignity of conception and is rendered with strength and lofty simplicity. Mr. John Lavery is represented by three examples, of which *The Lady in Black* is the most important. Mr. Charles Conder's *Au bord de la mer* is a beautiful colour harmony, while *A Blue Seascape*, by Henry Moore, shows the finest qualities of the marine painter's art.

**V**IENNA.—When some two years ago the citizens of Marienbad decided to erect a monument to commemorate the memorable meeting of the two monarchs, the Emperor Francis Joseph and King Edward VII. of



FROM THE WATER-COLOUR IN THE POSSESSION OF T. WAY, ESQ.







## Studio-Talk

England, Gustav Gurschner was entrusted with the task, which he has ably fulfilled. It was no easy task which the sculptor undertook, for there were many difficulties in the way even after the form it was to take was definitely fixed upon. The features of the Emperor were familiar to him, but it was otherwise with the King. With his usual thought and kindness, King Edward smoothed the way by sitting to the sculptor four times during his stay in Marienbad last year and once in London, whither the sculptor had followed him. The King is highly satisfied with the medallion portrait of himself, which is a dignified work. The artist has brought out the characteristic lines of his face, and the likeness is unmistakable. That of the Emperor Francis Joseph is equally good, though his Majesty, owing to his advanced age and the need for avoiding fatigue, did not sit to Herr Gurschner. Still, in this case also, the portrait has been pronounced by those in intimate intercourse with the Emperor to be an excellent likeness.

The monument of which these medallions form part is also the work of Herr Gurschner. It is of finely-hewn, unpolished granite of a soft grey tone,

and with the socle, which is slightly curved, is over thirteen feet high. The medallions are twenty inches in diameter, and have been executed in bronze; they occupy the face of the stone, which also bears an inscription relating to the event commemorated. On either side are two pilasters about eight feet high with seats between, also of grey granite, the whole forming almost a semi-circle. The pilasters are ornamented with bronze crowns of the monarchs, and surmounted by bronze-gilt Etruscan vases with a rich patina, and containing plants and flowers. The whole is something entirely new in monumental sculpture, for this mixture of bronze patina and hewn granite has never been used in this connection in Austria. The monument is situated in an ornamental garden at the head of a walk which was specially made for the use of King Edward, so that he might be far from the "madding crowd," and yet one of them. Herr Gurschner has achieved a real work of art, which will be an ornament to Marienbad.

Friedrich Gornik, of whose plastic productions some examples are here reproduced, is a native of Carinthia, and began his career as a student at the Fachschule in Villach, one of the best-known



"DRAUGHT HORSES"

MODELLED BY FRIEDRICH GORNIK  
EXECUTED BY A. RUBENSTEIN

schools for wood-carving in the Imperial dominions. He was then but fourteen, but as he showed unusual ability at the end of the four-years' course of instruction there, he was awarded a stipend in order that he might continue his studies at the Kunstgewerbeschule in Vienna. Before entering this institution, however, he studied for a year under Theodor Charlemont, an artist of sound judgment, and possessing unusual merits as a teacher. At Vienna he was first a pupil of Professor Breitner, and later, when the school was re-modelled by Baron Myrbach, the young sculptor entered the class of Professor Strasser, one of the leaders of the Secession, appointed at the same time as Professors Hoffmann, Moser, and other moderns. Gornik quickly distinguished himself as a student in Vienna, and at the end of his course was awarded a travelling scholarship in order that he might study the plastic art of other nations.

Gornik early developed a taste for animal sculpture, and in the zoological gardens at Schönbrunn in the grounds of the famous castle, he found sufficient and varied material for studying them from nature. These studies were carried on at a time when garden architecture was beginning to claim

more and more attention on the part of artists of the modern school, and Gornik also turned his thoughts in this direction, one of the results being *The Lovers*—a work showing how closely Gornik has studied animal nature. The modelling of this feline couple is vigorous and full of feeling, while the facial characteristics are aptly rendered, as also is that suppleness of limb and body which distinguishes animals of this kind.

Not content to confine his studies to the wild animals at Schönbrunn, Gornik turned his attention to the domestic animals he had been familiar with in his country home—the oxen and horses employed in husbandry. Both in the *Team of Oxen* and *Draught Horses* there is something almost human in the dignity with which these toilers are invested. Remarkable too for its powerful delineation is the *Troika*, which was lately exhibited at the Künstlerhaus and so impressed the Kaiser that he bought it. Nor has he restricted himself to animals, though it is here that his particular gifts are revealed most conspicuously. Among other human subjects he has modelled, the *Wrestler* may be mentioned as an example of this talented young sculptor's vigorous manipulation.

A. S. L.

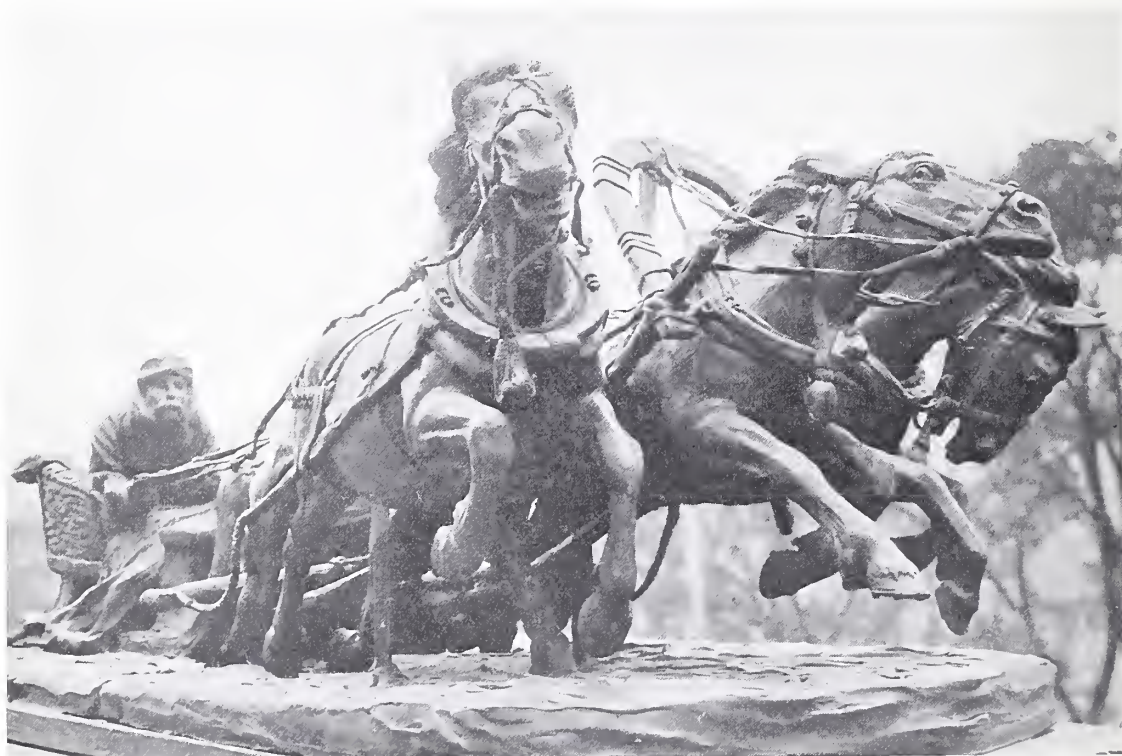

"TROIKA" (BRONZE)

BY FRIEDRICH GORNIK  
EXECUTED BY A. RUBENSTEIN



"TEAM OF OXEN" (BRONZE)

MODELLED BY FRIEDRICH GORNIK  
EXECUTED BY R. LEITNER

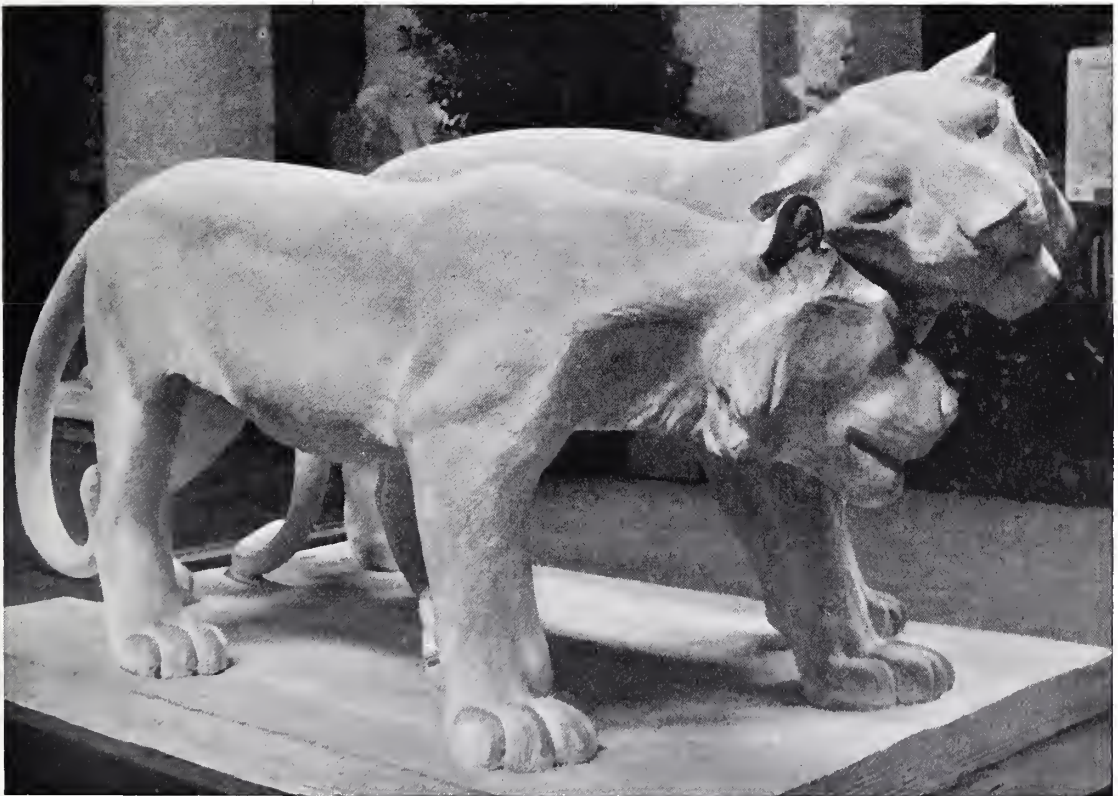

"THE LOVERS"

BY FRIEDRICH GORNIK



“ON THE MULDE”  
BY HANS LICHT

**B**ERLIN.—An exhibition of the studies and drawings of Count Leopold von Kalckreuth has been on view at the Cassirer Gallery. We enjoyed the patient love of a student of nature, and that delicate rendering of every-day life in the home and the fields which is the source of the painter's inspiration. A sober realism does not look out for things of beauty, but problems of light and air are carefully studied, and we sometimes feel the touch of a loving soul.

One of the most promising young landscape painters, Hans Licht, is to be seen to great advantage in the Künstlerhaus Gallery, and readers of THE STUDIO will be interested in seeing the example of his work here reproduced.

At Fritz Gurlitt's Gallery recently there was an interesting exhibition of landscapes by Paul Thiem. These landscapes are confessions of quiet German "Heimatgefühl" (home-feeling). The painter is a son of the distinguished Berlin collector, Adolph Thiem, whose treasures are now in the Kaiser Fredrich Museum.

The future of German applied arts has been unceasingly debated since the important Dresden exhibition closed its doors. There are pessimists who conclude from this great review only a return to past styles. Biedermeier is the craze of the day—Biedermeier for home arts, for high art, and literature. Two Biedermeier exhibitions have recently been revivifying the Alt-Berlin of 1820—1860. Optimists only speak of the new style. We cannot yet quite specify this new style at the present moment, but we have certainly every reason to expect it. Biedermeier, the last pure phase of German art, seems a

healthy connecting-link between tradition and modernism. Although our Berlin decorative artists enjoy no State protection, as do the Vienna, Munich, Dresden, and Darmstadt guilds, although they are real stepchildren of the public, yet their strong development shows their vital force. Events such as the appointment of Professor Messel as "Hof-Architekt," of Professor Bruno Paul to the post of Director of the Royal School of Applied Art, the introduction of a series of lectures on "Moderne Kunstgewerbe" in the lately-opened Handelshochschule (Commercial High School), are hopeful signs of good times coming for Berlin applied art. A group of our strongest talents, such as Albert Gessner, Curt Stoeving, Grenander, August Endell, Rudolf and Fia Wille, Sepp Kaiser, Mohrbutter, Schmuz-Baudiss, Mutz, have banded together to form the "Werkring." This association does not



VIEW OF DINKELSBÜHL (Photo: Hanfstaengl, Munich) BY PAUL THIEM



NYMPHENBURG PORCELAIN FIGURE  
DESIGNED BY JOSEPH WACKERLE

hopes to procure many surprises by this proceeding. His favourite model is a rather repulsive elderly coquette who might have fascinated the pencil of Beardsley or the pen of Prévost. She is quite as fit in her lengthy grace to pose in up-to-date *chic* as in old-fashioned style. She can serve for the expression of the [perverse, the comic and the homely. In each position and costume the artist understands how to make her perfectly convincing by his very precise and sharp-lined modelling. This is at once so evident that we do not even miss colour in the white figures. Wackerle may be destined to immortalise modern female types in porcelain portraits.

August Endell, one of those named above as having united to form a "Werkring," is causing great astonishment in connoisseur circles with his new building at the Hakesche Markt. In Munich several years ago he, with Van der Velde and Obrist, formed the revolutionary trio which stood up for modern ideas. There his Elvira Studio was as much criticised for eccentricity as, later on, his Wolzogen Theatre in Berlin. Yet Endell was only groping after the way which to-day he is treading with perfect clearness. He always wished for the new style, now he knows it can be realised

pledge its members to certain dogmas ; it leaves them free to follow their own artistic bent, only strengthening their aspirations by the community of aim and by *camaraderie*. It seems that the strongest impulse is traceable from Scotland, England, and Vienna, yet there are unmistakable personal notes.

Visitors to the Bruno Paul rooms in the Grosse Berliner Kunstausstellung cannot fail to have noticed the porcelain figures of the Munich sculptor Joseph Wackerle. This artist is at present occupied at the famous Nymphenburg manufacture, which is bent on augmenting its long established reputation. He adores the fine material he so deftly manipulates and thinks it quite as fit for our time as for the Rococo and Louis Seize. He tries to make it particularly effective by original designs. He either leaves his figures white or colours them in strong but most harmonious tones under the glaze. This method is adopted for the first time in porcelain figures, and Wackerle



NYMPHENBURG PORCELAIN      DESIGNED BY J. WACKERLE



STAIRCASE OF THE HAKESCHE HOUSE, BERLIN  
AUG. ENDELL, ARCHITECT

by a far deeper study of nature and, before all, by the sovereign inventive faculty of genius. Imitation and eclecticism are in his opinion the death of development. He is convinced that modern times, with their utilisation of scientific results and machine work, demand new artistic utterances. We see an architectural energy at work which is able to shape masses under the compulsion of one dominating idea, and to accentuate and vary this idea by an infinitude of detail. We sometimes seem to feel in vaulting lines and undulations the spirit of barockism, or, in vertical structures, the Gothic spirit. We are reminded of the Orient and of the Occident, but an unflinching will always evolves a personal vision.

Our illustrations give an idea of Endell's inventiveness in the disposition of space and in the detail. The small hall in the Hakesche Haus can be easily divided into two rooms, and the weight of the ceiling is made light by a most original structure of the column-capitals. The staircase shows a peculiar use of the walls and very original columns.

Throughout this undertaking, and especially in the large festival hall, Endell reveals himself not only as a student of nature, but as her spy. He is not content with external forms, but seeks to penetrate the secrets of inner structure—the life principle. Leaves, insects, primitive plants and animals, or rather their fibres, veins, tissues and skeletons are the domain of his investigations, and what he discovers is disclosed in the sprouting and bristling, the flickering and crinkling of his ornaments. We may call him queer, sometimes almost pathologic, but his architectural discipline always fills us with confidence.

Otto Schulz, a young and highly talented architect, is a pupil of Professor Alfred Grenander in the Berlin Royal Arts and Crafts School. His excellent pen drawings have won the first prize in a competition given by a trade journal. The task was a design for a garden-house and another for a garden-fence. Otto Schulz sent in two solutions for each theme, and his designs pleased by their unpretentiousness and



SMALL HALL, HAKESCHE HOUSE, BERLIN  
AUG. ENDELL, ARCHITECT

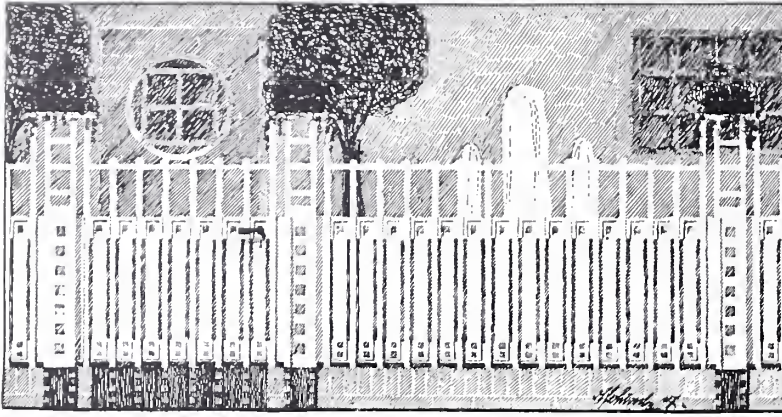

GARDEN FENCE

BY OTTO SCHULZ

practicability. He drew an octagonal and a quadrangular pavilion, each covered with a roof of shingle-wood. The particular charm of these competitive works lay in the exquisiteness of Schulz's architectural drawing.

The Secession has made an effort to assume a particularly German character this year, and the result is a very interesting exhibition. There is a good deal of strong work and some really refined productions. Max Liebermann is on a classic height in most of his works between 1876-1896, but his latest *coup de force*, the portrait group of the *Hamburg Professors* impresses one in many respects as unsatisfactory. Louis Corinth is the only one among German artists with a Rubenese vein, but void of the Flemish grandseigneur's quality of noblesse. Max Slevogt cultivates interesting colour-schemes and vivid delineation, and Leistikow's landscapes sound the rhapsodic note as strongly as the idyllic. Ulrich Hübner's pictures from the North German waterside carry the freshness of breeze and flood with them, and Heinrich Hübner understands how to add interesting features to the quiet charm of re-

Charlotte Berend. That still-life in its utmost refinement is becoming a prominent feature here is significant, and may, it is hoped, tend towards a more peaceable spirit in this dissident art centre.

J. J.

**A**MSTERDAM.—With the renaissance of our national art of painting in the last four decades of the nineteenth century, there was a kindred revival of the graphic

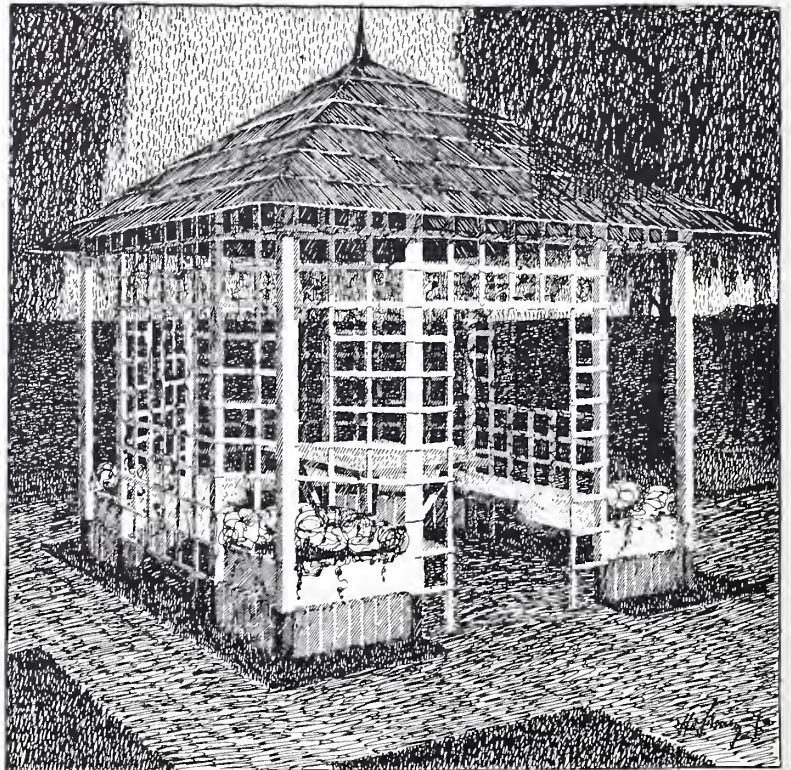

SUMMER HOUSE

BY OTTO SCHULZ



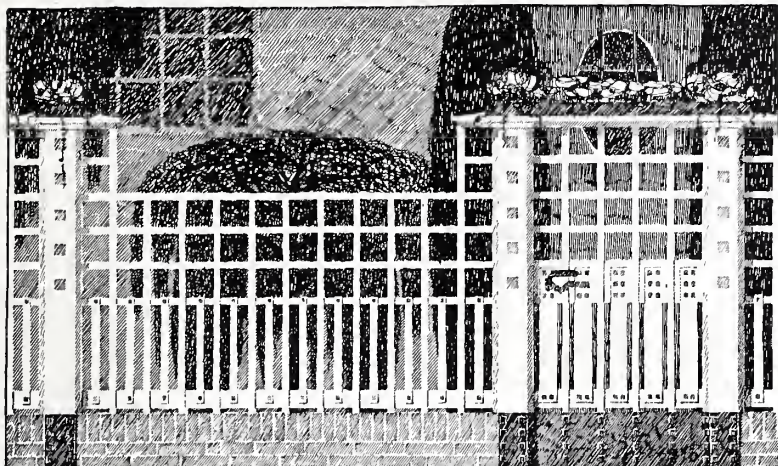

GARDEN TERRACE

BY OTTO SCHULZ

arts which claims the attention of the serious student who wishes to clearly understand the importance of the recent art-movement in Holland. It was only natural that artists who, like the brothers Maris, like Mauve, Bosboom, and those other gifted workers who took up the historic line joining them *via* the Barbizon school and England (Constable) with their ancestors of the seventeenth century, should take a profound interest in and show a well-understood admiration for the masterpieces of graphic art produced in those long by-gone days. Could they have found a better teacher than Rembrandt?

However, it was not by those I have named that graphic art has attained to the position it now holds. The original plates by an Anton Mauve are limited to eighteen, the number of James Maris's graphic works is not half a dozen, those of his brother Matthew may be ten or eleven. It was a younger generation which made its glorious fight at the Paris Exhibition in 1900, where, in the graphic department, Marius Bauer, then thirty years of age, stood in the front row, equally admired and

prints and collecting them never became so popular as the appreciation for pictures, and Holland being but a small country the short life of the society may be explained.

This summer two coincident exhibitions have again drawn public attention to graphic art. The two leading art societies at Amsterdam, the Societas

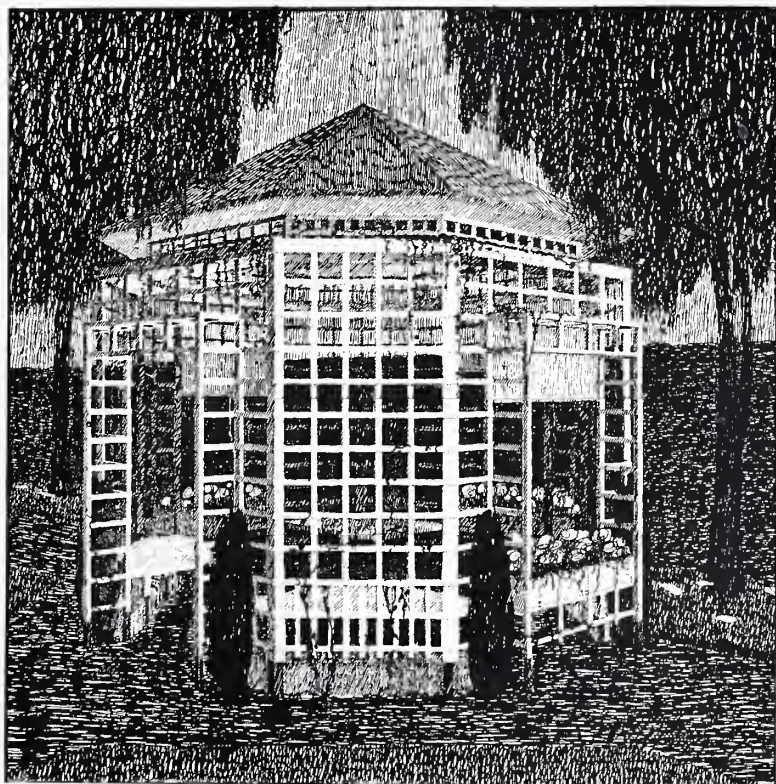

SUMMER HOUSE

BY OTTO SCHULZ

Arti et Amicitiae and St. Lucas, both organised an exhibition of original etchings, engravings and lithographs by their members, and (in the former) by their immediate predecessors. Thus, at the Art Society's we found a nearly complete set of Mauve's etchings. An important selection was also exhibited from the work by Witsen Dupont, de Zwart, and especially by Bauer, one of whose recent works was reproduced in the June number of this magazine. Willem de Zwart's work is not yet esteemed outside Holland as much as it deserves; but his original etchings now already surpass the number of one hundred. Another promising young engraver and lithographic artist made his first appearance in Amsterdam at St. Lucas. I must note also the names of some other young artists whose graphic productions are worth attention and who exhibited in both collections. They are Haverkamp, Veldheer, Jan Boon, Graadt van Roggen and Derkzen van Angeren. Nor must I omit to mention the twelve relatively small plates exhibited by Mr. Tholen, an artist whose work is appreciated by the Americans still more than by his own countrymen. DE WM.

**D**ÜSSELDORF.—The Deutsch Nationale Kunstausstellung which is being held here, is, as its title implies, a national display, being restricted to modern German art. It is a comprehensive collection of works by artists of many schools, from Menzel to Liebermann, from Klimt to the old Viennese master, Rudolf Alt. The space at the disposal of the authorities did not impose upon them the necessity of picking and choosing, hence the indiscriminate quality of the show as a whole.

The chief note, the *clou*, so to speak, of the entire display is a really meritorious collection of water-colours—a medium in which English and French artists have made a greater mark of late than German artists. There are good efforts and fair results attained, however, among the Düsseldorf painters themselves in this department. I may mention such men

as Böninger, whose large drawing of three crab-catchers on the coast of Brittany, standing in a boat in the waning twilight, is one of the most able performances. ¶ There are also some fine clear drawings in pastel and pencil by Walter Georgi Hambüchen and Max Clarenbach; also by Lissmann (of Hamburg), Bergmann in gouache, and Richter and Hengeler (Münden). Schönleber (of Carlsruhe) contributes some very select examples of landscape, of a serenity rarely equalled. Professor Claus Meyer is represented by *Alt Düsseldorf*, a reminiscence of the old Rhenish town in the middle ages, with its quaint roofs, turrets, and trading-craft of the Columbus type, with high fore-castle and quarter-deck, anchored on the river.

W. S.

**B**RUSSELS.—To Victor Gilsoul, whose picture, *Old Embankment at Bruges*, is given as a supplement in this number, an article was devoted in THE STUDIO



"SERSHEIM"

BY GUSTAV SCHÖNLEBER



LANDSCAPE  
BY A. HENGELER

about three years ago, and the chief facts of his prolific career and the characteristics of his art were touched upon therein. Few, indeed, among the modern painters of Belgium have risen into prominence so rapidly as Gilsoul. More than twenty years have elapsed since he made his *début* in the Salon here, and he is still barely forty. He is a *plein-air* worker and finds his chief delight in depicting the scenery of Flanders with its windmills, its long lines of trees, and, above all, its pellucid, gently flowing canals linking up the centres of human activity. To a painter of Gilsoul's temperament, Bruges with its wealth of old-world associations could not but have a powerful fascination, as it has, indeed, to many others besides. But how long will the capital of West Flanders continue to exercise this fascination—that is the question prompted by the great event which makes the present year a memorable one in her history. The augmentation of her commercial and industrial life which is almost sure to result now that she has become once more a port with direct access from and to the high seas, is pretty certain to bring with it a transformation in her external appearance. Perhaps there are not a few who look forward with feelings other than pleasurable to the time when Bruges can no longer be called "*la morte*."

B. J

**T**ALASHKINO, SMOLENSK.—  
The accompanying illustrations of designs by MM. Röhrich, Zinovief, Maliutin and Princess Tenishef are intended to supplement those which appeared in the July number of THE STUDIO, when M. de Danilovicz gave an account of the schools and workshops established and carried on at this place by Princess Tenishef with the assistance of various artists, who, like herself, have at heart the revival of the old Russian peasant crafts. Particular interest attaches to the theatre which the Princess has had erected in proximity to

the ateliers for the purpose of affording healthy recreation for those engaged therein. This theatre, of which illustrations are given of the exterior and the auditorium, was designed by M. Maliutin (who also designed most of the accessories), and is capable of seating two hundred persons. As will be seen (pp. 332-3), it is a one-storey wooden building, well-lighted laterally by a series of windows somewhat close together, the interspaces being occupied by carvings which recall those seen even nowadays on the vessels which pass up and down the Volga and its tributaries and the rivers of Northern Russia. Princess Tenishef has in her museum at Smolensk a remarkable collection of such carvings, some of which go back to the beginning of the seventeenth century, while others belong to the period of Peter the Great and Catherine, and a few to still later times. The auditorium of the Talashkino Theatre is carried out in a restrained style; the ceiling is of plain straight boards; the walls are smooth, surmounted by a cornice forming a broad band of ornament in which the traditional peacock, leaves and flowers form the *motif*; the carved seats are made with the typically Russian high backs; the doors are carved and painted; and the drop-curtain displays a peasant girl playing the dulcimer (*gussli*).



"WINTER"

BY MAX CLARENBACH



"OLD EMBANKMENT AT BRUGES." BY VICTOR GILSOUL.





DECORATIVE FRIEZE

DESIGNED BY N. RÖHRICH

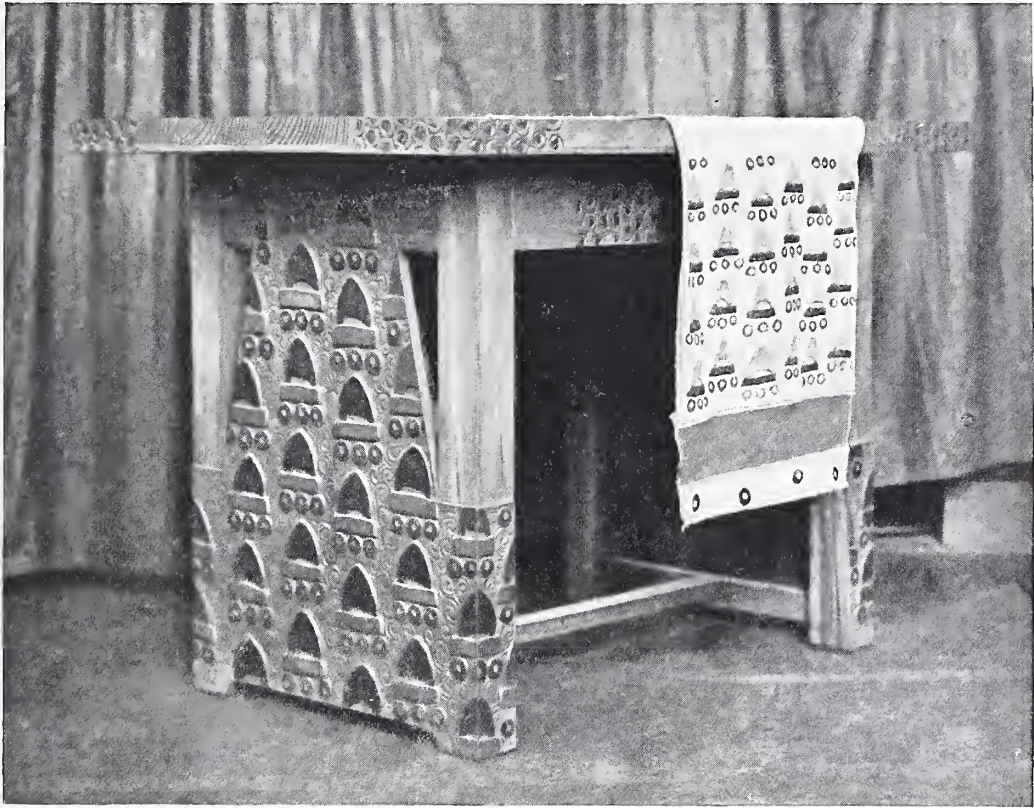

TABLE

DESIGNED BY A. ZINOVIEF



DECORATIVE FRIEZE

DESIGNED BY N. RÖHRICH



THEATRE AT TALASHKINO  
DESIGNED BY S. MALIUTIN



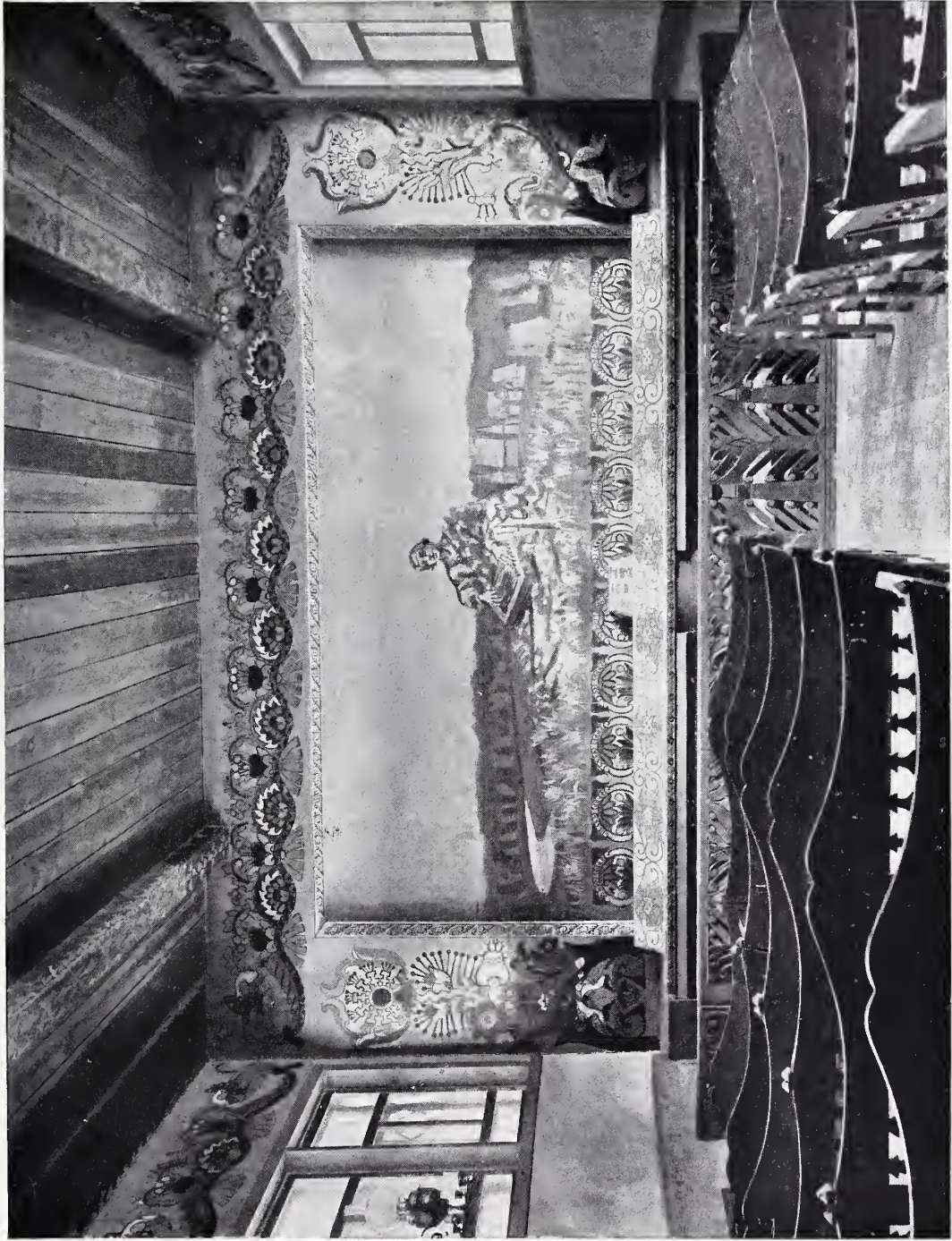

INTERIOR OF THEATRE AT TALASHKINO  
DESIGNED BY S. MALIUTIN

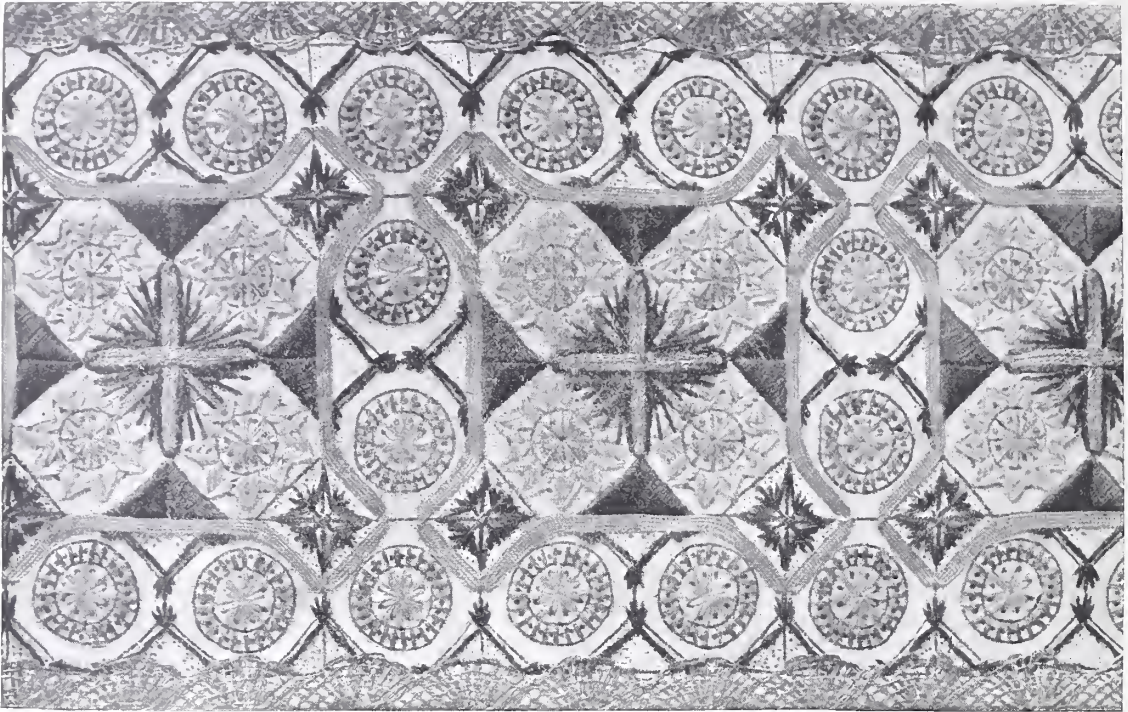

PORTION OF EMBROIDERED STOLE

DESIGNED BY PRINCESS TENISHEF (TALASHKINO)

And then not only are the national characteristics seen in every detail of the structure itself, but the little plays and operas performed there under the direction of the indefatigable Princess Tenishef, whose assistants and pupils constitute the *dramatis personæ*, derive their themes from the legendary lore of Old Russia. Princess Tenishef herself often writes the libretto and designs the costumes worn by the performers. The instrument employed for orchestral purposes is the national *balalaika*, and this too has claimed a share of attention on the part of the artist staff connected with the establishment.

#### REVIEWS AND NOTICES.

*The Art of the Greeks.* By H. B. WALTERS. (London: Methuen & Co.) 12s. 6d. net.—This book will especially commend itself to artists. The author has thoroughly perceived that the history of Hellenic art derives its significance from the essentially plastic genius of the Greeks, that pursuit of visible beauty which gradually took their art away from the inward and religious significance with which it started. He emphasises the fact that their athleticism, at first entirely religious in its associations, gradually divorced art from religion as the idea of mere physical beauty began to prevail, though it was not until the end of the fifth century that statues were created for a purely æsthetic

end. The author inserts a carefully-arranged chronological scheme of Greek art. He deals in an interesting manner with recent explorations in Crete, which open out a new world of artistic creation and reveal a state of civilisation which seems almost incredible at the remote date of 2000–1500 B.C. In the separation of the art of painting from handicraft, at which point the independent history of Greek painting begins, he remarks the impetus which the new movement received by the changes at Athens under Kimon and Pericles, when public buildings were being erected to commemorate great events and appropriately decorated with frescoes of historical and mythological composition. The chapter on Greek vases will help to dissipate the popular use of the term “Etruscan” in reference to the painted vases of the Greeks. He treats us to exhaustive criticism of Greek gems and coins, and deals very interestingly with the origin of metal-working. As a whole the book is written with singular lucidity and charm, and is evidently the flower of deep and painstaking scholarship. It is attractively bound and profusely illustrated by excellent plates.

*The History of Painting.* By RICHARD MUTHER, Ph.D. (London and New York: G. P. Putnam's Sons.) Two vols., 21s. net.—Well translated into English, and supplemented by a series of reproductions of typical masterpieces and by an excellent

## Reviews and Notices

index giving the dates of the births and deaths of the artists noticed, this new edition of Dr. Muther's well-known work will no doubt find a place in many art libraries. But the praise lavished on it by the American editor will not, we think, be fully endorsed by those familiar with the many authoritative histories of art in circulation on this side of the Atlantic, for the author, though there is a certain originality in his method (which is rather psychological than chronological) does not take the very high rank amongst art critics of the day claimed for him. In spite, however, of certain peculiarities of style, he has brought together in a convenient form a vast amount of information, and now and then hits on a very apt comparison, notably when he calls Jan Steen the "Molière of Dutch painting," and Boucher the Correggio of the Rococo style. Perhaps one of his best essays is that on Rembrandt, with whom he appears to be peculiarly in sympathy, for he recognises very clearly the dual nature of the great master, whose life, dominated from first to last by conflicting influences, was indeed, as he says, "a tragedy of fate."

*Canada.* Painted by T. MOWER MARTIN, described by WILFRID CAMPBELL. (London: A. & C. Black.) 20s. net.—The author of this new volume on Canada evidently knows the country well, and is to a great extent in touch with its inhabitants, but unfortunately his gift of expression is not altogether equal to the amount of his information. He has much to say, but somehow has not succeeded in saying it effectively. He makes no attempt to write a history of Canada, claiming as his excuse for the omission of what would have been a most interesting record, that the country is a new one, and "not the stage of centuries of human struggle and effort in the sense that European countries are," yet, as a matter of fact, that history has been from the first full of episodes as thrilling as anything that has taken place on this side of the Atlantic. Canada, as the writer himself points out, is the Scotland of America, and he might well have compared the struggle between the French and English there with that between the latter and the Scots before the long feud was ended by the union of the two countries. In dealing with the great towns, however, he fortunately departs from the rule laid down, describing many thrilling episodes connected with their foundation, bringing down their life-stories to the actual present, and taking care in every case to give details that will be of use to the would-be settler, thus adding greatly to the value of his work. The water-colour drawings of Mr. Martin show in a noticeable degree the defects

of his literary collaborator, for with the exception of the mountain views, which are sympathetically interpreted, they are essentially matter-of-fact, topographical rather than artistic, and greatly wanting in poetic feeling.

*Essentials in Architecture.* By JOHN BELCHER, A.R.A. (London: B. T. Batsford). Cloth, 5s. net; leather, 7s. net. "All good architecture addresses itself to the emotions as well as to the mind. . . . A building, however sound and good on the scientific side, can never be elevated to the rank of architecture by simply dressing it up in ornament. The artistic spirit must be at work from the very first." "Architecture is not a science plus art, but a science interpenetrated in all its methods and applications by the true spirit of art." In such sentences as these, which we find in his introduction, Mr. Belcher sounds the keynote of a book every line of which is pregnant with interest alike to the cultured general reader and to the professional student, whose attention is called to those first principles and ultimate ideals which he is apt to overlook in the maze of practical details. The book treats of architecture as a fine art, and the exposition is conveniently and logically arranged under the heads of Principles, Qualities, Factors, and Materials. The illustrations, which are numerous and well printed, have been specially selected to give point to remarks in the text, and range from buildings of palatial proportions to the humble cottage of the country side.

*Pierre Puget: Décorateur et Mariniste.* By PHILIPPE AUQUIER. (Paris: D. A. Longuet.) Fr. 50.—Born in 1662, at a time of exceptional naval activity not only in France but in England, Pierre Puget, the contemporary of the famous Secretary of the British Admiralty, Samuel Pepys, enjoyed a great reputation during his lifetime as a designer of the ornamentation of ships, and also some little fame as a painter of marine subjects and sculptor. Before he was seventeen, he is said to have taken a considerable share in the decoration of several vessels that aided in the great naval victory over the Spanish fleet in 1638. At the end of his term of service he went to Italy to study, walking all the way to save expense, and on his return home, five years later, he obtained the important post of Superintendent of the Arsenal of Toulon, which he held for many years, during which some of the finest and most richly-decorated vessels ever produced in France were launched. Unfortunately, however, the sudden change that took place towards the close of the reign of Louis XIV. in the opinion of the authorities as to what was

essential in naval architecture, led to an unexpected check in the brilliant career of the master designer, who found himself without congenial employment just when everything had seemed most promising. He withdrew to Marseilles only to meet with a similar experience there, and though he continued to work in other directions until his death, in 1694, his memory was soon forgotten outside the actual scene of his activity. It was reserved to the present Curator of the Musée des Beaux-Arts at Marseilles to restore to him his true place in the history of decorative art, and to give the public an opportunity of judging for themselves of the beautiful designs that are preserved in that Institution. To the fine reproductions of more than fifty typical drawings, displaying in a remarkable degree Puget's fertile imagination and skill of draughtsmanship, he has added an exhaustive catalogue *raisonné* of all the works of Puget that have been preserved, including paintings, sculptures, and designs for carving.

*The Outskirts of the Great City.* By Mrs. A. G. BELL. With coloured illustrations by ARTHUR G. BELL. (London: Methuen). 6s. net.—Gifted with a fluent and engaging style of writing, Mrs. Bell, in this latest book from her pen, conducts her readers on a tour of the places situated on the fringe of London, recalling the historic associations in which they abound and noting the changes they have undergone down to the present time when these once isolated hamlets and townships have become practically merged in the great metropolis. So great have these changes been that one is apt to forget that many of these places whose vicissitudes Mrs. Bell describes in her entertaining narrative, have their individual histories dating back centuries. With the pictorial accompaniment provided by Mr. Bell, whose excellent and well-chosen illustrations in colour are supplemented by photographic views, the book should not fail to stimulate interest in these time-honoured spots.

*Scenes in the Life of Our Lord.* Drawn by HAROLD COPPING. Described by HANDLEY C. G. MOULE, D.D., Bishop of Durham. (London: Religious Tract Society.) 16s. net.—The outcome of many months' work in the Holy Land, the water-colour drawings reproduced in this volume well fulfil the aim of the artist, which was to depict Gospel incidents in the actual environment in which they took place. They are strictly realistic, leaving nothing to the imagination, and they make little or no attempt to suggest the spiritual teaching of our Lord; but they are full of human interest, and will serve admirably

to arouse the attention of the young, for whom they are evidently primarily intended. Their draughtsmanship and colouring are good, and their composition natural and effective. The *Miracle of the Loaves and Fishes*, the *Little Child set in the Midst*, *Lazarus, come forth!* and *Gethsemane* are especially noteworthy, telling their story with simple directness and comparing favourably with other modern interpretations of the same themes, even with those of M. Tissot in his well-known "Life of Christ." The accompanying notes from the eloquent pen of the Bishop of Durham form an excellent supplement to Mr. Copping's illustrations, and the work will no doubt be welcome in many a home, though its high price will probably prevent its use in schools.

*The Old Engravers of England.* By MALCOLM C. SALAMAN. (London: Cassell & Co.) 5s.—This book deals with the engravers of England in their relation to contemporary life and art. The letterpress is accompanied by forty-eight illustrations—admirably selected from the point of view of suitability to the technical remarks on engraving. The attempt has been made, and made successfully, to trace the art of copper-plate engraving through the most interesting period of its history; but the author tells us he has had no thought for those print-collectors with whom considerations of "state" are more urgent than the appeal of pictorial beauty or human interest. Upon this point we tender the author our congratulations, though we should not be able to do this had the technical side of Mr. Salaman's book suffered from superficial treatment of the subject. For, after all, in dealing with engravings, what is really of value is evident knowledge of the subject and ability to impart some of the pleasures of this branch of knowledge to others. Even if the would-be collector intends to be actuated by the absorbing historical interest attached to engravings, he must seek that human interest at the point where it finds its most worthy and beautiful representation, and be able to distinguish between the excellences of certain states and the absence of beautiful quality in others. This ability is most often an instinct which enables its happy possessor to find interest in the dry side of the knowledge, which is the backbone of any true appreciation. The ideal collector is he who has this instinct, supported by knowledge, but who has also felt the fascination of looking in at all the side doors upon history which old prints open. Mr. Salaman is such an ideal collector, and so proves himself a true guide for the novice and a companion of the already wise—meeting the

## Reviews and Notices

latter on gossipy grounds, in that elusive atmosphere of "tea-cup" times which old engravings more than anything else have the power of reviving.

*Art and the Camera.* By ANTONY GUEST. (London: G. Bell & Sons.) 6s. net.—Those who in spite of the abundant evidence furnished by the productions of leading photographers in Europe and America, still contend that photography can never come within the category of art, would do well to peruse this volume, the chief aim of which is to set forth the principles underlying artistic work. Mr. Guest's position is a thoroughly sound and reasonable one; he makes no extravagant claims for photography, recognising that only in its higher phases and when controlled by operators who are endowed with artistic feeling can it yield results that can rightly be called artistic. The difference between artistic and mechanical photography is, in fact, pretty much the same as that between artistic and imitative painting; in both cases it depends upon the worker and not upon the implements he uses whether the product is artistic. The numerous reproductions of photographic pictures which accompany Mr. Guest's exposition are from prints by well-known workers in photography, and, though in some cases they hardly do justice to the originals, they disclose qualities which undoubtedly justify their being regarded as works of art.

*William Blake.* Vol. I.: Illustrations of the Book of Job, with Introduction by LAURENCE BINYON. (London: Methuen.) 21s. net.—Admirers of the work of William Blake, and their numbers have of late years been continually on the increase, will eagerly welcome the very beautiful reproductions of the masterpiece of his maturity—the wonderful series of illustrations of the Book of Job, in which he appears at his best alike as designer and engraver. The subject evidently had a peculiar fascination for Blake, and his marvellous conceptions tell with a convincing force, never surpassed, the pathetic story of the undeserved sufferings of the patriarch and the final triumph of his patient faith in the justice and mercy of God, in spite of all the misery heaped upon him for no apparent reason. In the three introductory essays Mr. Laurence Binyon displays remarkable insight into the character and aims of Blake, and defines his peculiarities with subtle discrimination. Dealing in the first with the poet-painter as a man, in the second essay he proceeds to define the distinctive qualities of Blake's work as an artist, special stress being laid on the fact that in the Job designs the two long conflicting strains in their

author's style, "were grandly married and made one." Of Blake's poetry also he shows himself a most discriminating critic, but it is, perhaps, in his notes on the individual Job engravings that he best shows his appreciation of the essential qualities that set them apart from all previous productions.

The second volume of Dr. de Gray Birch's *History of Scottish Seals* published by Mr. Eneas Mackay of Stirling, was noticed in one of our recent numbers, but as no reference to the first volume has appeared in these columns, we should mention that it deals with the Royal Seals of Scotland, the illustrations, of which there are fifty-three, beginning with the seal of King Duncan II., and ending with the Scottish Seal of King Charles I. of Great Britain. In this volume, as in the second, dealing with the Ecclesiastic and Monastic Seals of Scotland, Dr. Birch brings to bear his extensive knowledge of the subject, an interesting one alike to the historian and archæologist. The third and fourth volumes which remain to complete the work are to deal respectively with the Seals of Local and Corporate Bodies in Scotland, and Scottish Personal and Family Seals. The price of each volume is 12s. 6d.

*The Year-Book of Photography and Amateur's Guide for 1907-8*, published by "The Photographic News," under the editorship of Mr. F. J. Mortimer, contains in addition to the usual fund of useful formulæ, data and general information, some thoughtfully written articles by specially qualified writers on the different divisions of photographic work, each of them illustrated by numerous reproductions of appropriate prints. The price of the publication is 1s. in paper; 1s. 6d. in cloth.

For French workers in photography the *Annuaire général et international de la Photographie*, edited by M. Roger Aubry and published by Plon-Nourrit & Cie. (6 frs. cloth), is without a rival. The issue for 1907, which has recently made its appearance, contains numerous essays by recognised authorities, among which we note as especially interesting, an able treatise on the "Chemistry of Photography," by MM. Wallon and Mathet; two brief papers by Abel Buguet on "Radiology and Stereology," one on "Colour Photography," by M. Niewenglowski, and others on "Telephotography," "Stellar Photography," etc. The illustrations throughout are excellent.

---

Mr. Robert Little, R.W.S., requests us to state that he has no second Christian name. In our article on him last month he was erroneously called Robert W. Little.

THE LAY FIGURE: ON MIS-DIRECTED INGENUITY.

“How true it is that the evil that men do lives after them,” said the Art Critic. “In art, as in morals, the consequences of one wrong step seem to be strangely far-reaching and to lead to developments which could scarcely have been foreseen. One æsthetic mistake is sufficient to set up a false tradition which spreads all over the world and affects generation after generation.”

“Pessimist!” laughed the Man with the Red Tie. “Why this portentous gravity? What friend of yours has been committing unspeakable crimes? Tell us all about it.”

“No friend of mine,” returned the Critic; “I am not bewailing the misdeeds of anyone I know. My complaint is a general one and applies to principles rather than individuals, but I feel that it is justified, nevertheless.”

“No doubt,” said the Man with the Red Tie, “but we want to know what is the meaning of your dark sayings. Who has been setting up false traditions and upsetting the world?”

“Well; you have, of course, heard much of late of the vast commercial advantage which has resulted from the invention of aniline dyes,” said the Critic, “and you have noted, no doubt, how the recent death of the inventor of them has been made the occasion for many enthusiastic comments upon the wonderful nature of his discovery.”

“And quite rightly,” interrupted the Business Man; “the discovery to which you allude is one of the most important that has been made in our time. It has revolutionised many branches of trade, and has had a practically world-wide influence.”

“I know it,” sighed the Critic, “and for that very reason I lament that it should ever have been made. It has put into the hands of commercial men the power of controlling artistic production in a great number of directions, and of dictating the way in which many kinds of art work should be carried out; and when the commercial man gets art under his thumb the result is usually disastrous.”

“Nonsense!” cried the Business Man. “Commerce is the one thing which makes possible the existence of art. Without commercial encouragement the art worker would be helpless and would be starved out of existence.”

“Wait a bit!” broke in the Man with the Red Tie. “Do you really contend that what you call

commercial encouragement promotes the production of good art?”

“Certainly I do,” replied the Business Man; “it provides the art worker with a market for his wares and it helps him to find out in what directions he can most profitably apply his energies. Good art, I take it, is that which is in widest demand, and everything which enlarges the demand tends to improve the general quality of art production.”

“What a creed!” exclaimed the Man with the Red Tie. “I should have said that the art which was in widest demand was usually bad, and that the greater its popularity the worse it became in quality.”

“That is, perhaps, going a little too far,” said the Critic; “but there is a very large amount of truth in what you say. The popular demand is usually for an art of a comparatively low type, and as it is solely with the popular demand that the commercial man concerns himself, it follows that he usually encourages an inferior kind of art production.”

“But what has all this to do with aniline dyes?” asked the Business Man.

“More than you think,” replied the Critic. “The invention of these dyes has put at the disposal of commerce a cheap and effective way of appealing to the popular craving for crudity of colour. The colour effects attainable by means of these dyes please people who know no better—in other words, the majority of the public; and bad though these effects are, they have been accepted by commercial men as establishing a really popular colour standard. As a consequence, by the misdirected ingenuity of a single inventor, the colour taste of the world has been perverted. The mischief began in this country, and like a kind of contagious plague it has spread in every direction with extraordinary rapidity; every nation in turn has caught the infection. Not only has the colour feeling of Europe been demoralised, but we have taught the artists of the East to abandon their splendid colour traditions, and to adopt as a commercial expedient our new aniline convention. We have imposed upon them our crude ideas, and by applying the commercial screw have forced them, our superiors in aesthetic perceptions, to obey our ignorant dictation. The inventor himself is dead, but the evil he has done lives after him, and is being exploited by commercial men for their own advantage. And in this vast development of bad taste, art necessarily goes to the wall. Am I a pessimist? I do not think so.”

THE LAY FIGURE.

# The Steinway Art Department

**D**ESIGNS AND EXECUTES PIANO CASES IN ALL THE PRINCIPAL HISTORIC ARCHITECTURAL PERIODS to match and conform to the furnishings of any drawing or music room, no matter how elaborate. Special care is taken that the embellishments of the outer case do not interfere with the musical qualities of the piano. In these Art Pianos the beauty of outline is so masterly blended with the world-famous Steinway Tone that they will not only prove a lasting joy, but will put the seal of supreme approval upon the discriminating taste of their fortunate owners.

A choice selection of these Art Creations is always on view at Steinway Hall.

Designs and estimates furnished upon request.

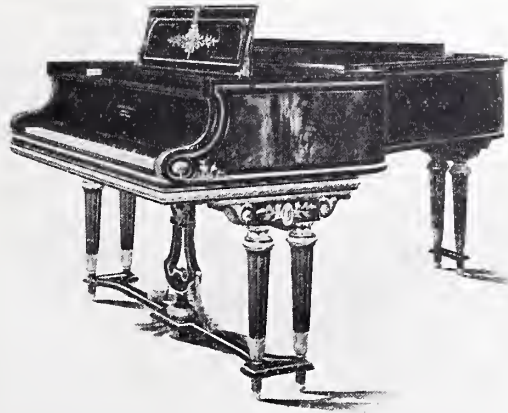

Louis XVI Mahogany Piano, with stretcher ornaments in gold; veneer on the rim, of light colored crotch mahogany; double legs.

**Steinway & Sons** STEINWAY HALL, 107 and 109 EAST FOURTEENTH STREET **New York**

*Subway Express Station at the Door*

## PLASTER CASTS



*Special  
Reduced Prices*

Antique, Mediæval and Modern Statuary. Suitable for the Decoration of Halls, Living-Rooms, Dens, Libraries and Studios.

Decorative and Architectural Casts for Schools, Colleges, Libraries, Art Classes.

*"The eye must be trained. We cannot know history without going to the records. We can never know Art unless we accustom the eye to the beauty of form."*

For Full Particulars of this Special Offer Address:

**INTERNATIONAL STUDIO**  
JOHN LANE CO., 110-114 W. Thirty-Second St., New York

## The **OLIVER** Typewriter

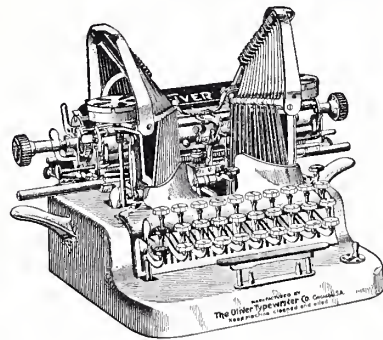

**The Standard Visible Writer**

Universal Keyboard  
The winner of awards everywhere  
Art Catalogue Free Ask for it

**THE OLIVER TYPEWRITER CO.**  
310 Broadway, New York City, N. Y.

# \$1500 in Prizes to Artists



IN ORDER TO PROVE to every artist in the country that Strathmore Drawing Papers and Boards are the best for an artist's use, we have decided to offer prizes aggregating fifteen hundred dollars for the best drawings executed upon Strathmore Water-color Paper under the following conditions:

**There will be Six Prizes—**

three for wash drawings and three for water-colors. The prizes are to be divided as follows:

**Two First Prizes of  
\$500 each**

**Two Second Prizes of  
\$150 each**

**Two Third Prizes of  
\$100 each**

The first prize for water-colors is to go to the best water-color drawing made upon Strathmore Water-color Paper—the best from an artist's point of view. The second prize to the next best, and the third prize to the third best. In the same way, three prizes for the first, second and third best black-and-white wash drawings.

**The Decision of the Judges**

is to be based entirely on the artistic merits of the drawings.

**All Drawings**

to be considered for this contest must be addressed to Prize Contest Department, Mittineague Paper Company, Mittineague, Mass., and must reach our office not later than five o'clock January 31, 1908.

**THE CONTEST WILL BE CONDUCTED UPON CONDITIONS GIVEN ABOVE**

Any one who wishes may secure a copy of these conditions with a more complete description of the aims and purposes of this contest, in the form of a small folder, also samples of the drawing paper, by writing to us or responsible dealers. Any art club, art school or group of artists may receive any number of these circulars, sent to one address, for distribution among members or others, if desired, by writing to address below.

**Prize Contest Dept., MITTINEAGUE PAPER CO., Mittineague, Mass., U. S. A.**

**There are no conditions as to  
style of work.**

Each artist is to make the style of drawing best suited to his ability and powers, the only condition being that the drawing should be either wash or water-color and made upon Strathmore Water-color Paper. Each artist may submit one drawing in each class, if desired, but no more.

**The Judges**

have been selected to represent the best ideas in art in this country. Their names are as follows:

**BLACK AND WHITE.**

Orson Lowell  
Edward Penfield  
Lucius W. Hitchcock  
Thomas Fogarty  
H.A. Thompson, *Art Ed., Saturday Evening Post*  
J. G. Sommer, *Art Editor, Collier's Weekly*

**WATER-COLOR.**

Frank X. Leyendecker  
Albert Sterner  
F. Luis Mora  
Arthur W. Dow, *Fine Arts, Columbia University*  
Wm. Martin Johnson, *Art Editor, The Delineator*  
J. H. Chapin, *Art Editor, Scribner's Magazine*



## EDVARD GRIEG

Illustrated Biography of the Norwegian Composer (who died last month) by the Well-known Critic  
HENRY T. FINCK

12mo. \$1.00 net. Postage 8 cents.

"An ideal biography."—BOSTON ADVERTISER.

"Wholly delightful, stimulating and virile."—CHICAGO EVENING POST.

Bibliography and Complete  
List of Works with Dates.

## ALFRED BRUNEAU

A Profusely Illustrated Biography by ARTHUR HERVEY.

12mo. \$1.00 net. Postage 8 cents.

"A model of what a brief biography of a living composer should be."—LONDON TRIBUNE.

"Capital and adequate."—LONDON STANDARD.

Bibliography,  
List of Works, etc.

"Valuable."—EDINBURGH SCOTSMAN.

## POETRY AND PROGRESS IN RUSSIA

By ROSA NEWMARCH

With Six Full-page Portraits. 8vo. \$3.50 net. Postage 25 cents.

**A**N ASPECT of Russia which is too generally neglected. The brains of the nation, the leaders of its intellect. A descriptive record of the lives and work of the romantic poets, Poushkin and Lermontov; the popular poets Kolstov, Nekrassov, and Nikitin; Khomiakov, the Slavophil poet, and Nadson, a poet of the decadence, etc.



POUSHKIN

## THE ROMANCE OF KING ARTHUR

12mo. \$1.50 net. Postage 10 cents.

"In this volume Mr. Coutts has surprised us. A poet he was known to be. The discovery that he is also a dramatic poet comes unexpected. We wish that there was some chance of seeing it on the stage."

—LONDON TIMES.

## THE HERESY OF JOB

A Study of the Argument. By FRANCIS COUTTS.

With the Illustrations by WILLIAM BLAKE.

8vo. \$2.00 net. Postage 15 cents.

## POPE'S ILIAD OF HOMER POPE'S ODYSSEY OF HOMER

Illustrated Pocket Edition. Introduction by Professor A. J. Church. Richly illustrated with 24 full-page original Drawings by WAL PAGET.

16mo. Cloth, \$1.00 net each. Leather, \$1.50 net. Postage 10 cents.

## THE POEMS OF SAMUEL TAYLOR COLERIDGE



Edited with an introduction by ERNEST HARTLEY COLERIDGE, and numerous Illustrations by GERALD METCALF.

8vo. \$3.50 net. Postage extra.

**A** COMPLETE illustrated edition of the poems of the author of "Christabel," "The Ancient Mariner," etc. Several hitherto unpublished poems are included in this edition.



**JOHN LANE CO., 110-114 West 32d Street, NEW YORK**

## ABRAHAM LINCOLN

By ROBERT G. INGERSOLL. Frontispiece, portrait of Lincoln. 16mo. 75c. net. Post. 8c.

COLLECTORS' Limited Autograph Edition, three-quarters crushed Levant. Photogravure portraits of Lincoln and Ingersoll. Printed on Imperial Japan. Limited to 110 numbered autograph copies. \$25.00 net.

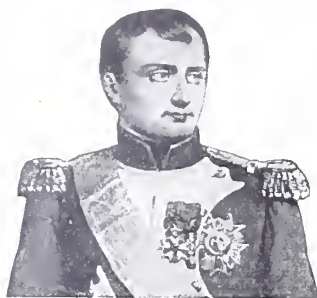

### NAPOLEON and the INVASION of ENGLAND

The story of the Great Terror, 1797-1805. By H. B. F. WHEELER and A. M. BROADLEY.

WITH 120 full-page illustrations, including eight in color, reproduced from a unique collection of contemporary Caricatures, Broad-sides, Songs, etc.

Two volumes. 8vo. \$10.00 net. Postage 40 cents.

### NAPOLEON at the BOULOGNE CAMP

By FERNAND NICOLAY. Profusely illustrated. Colored frontispiece. 8vo. \$3.50 net. Postage 25 cents.

## RALPH HEATHCOTE

Letters of a Diplomatist during the time of Napoleon, giving an account of the Dispute between the Emperor and the Elector of Hesse. By Countess GUNTHER GROBEN. Profusely illustrated. 8vo. Cloth. \$5.00 net. Express 25 cents.

## A SEA-DOG OF DEVON

A LIFE OF SIR JOHN HAWKINS. With an Introduction by LORD BRASCY and LORD LEYLAND. Frontispiece. \$1.75 net. Postage 15 cents.

THIS book is the first attempt of a biography of Sir John Hawkins, one of the most brilliant of the merchant adventurers, generals at sea and naval statesmen of the Elizabethan era, the kinsman and mentor of Sir Francis Drake.

## MEMOIRS OF ANN LADY FANSHAWE

Written by LADY FANSHAWE, with Extracts from the Correspondence of Sir Richard Fanshawe. Edited by H. C. FANSHAWE. Thirty-eight Full-page Illustrations, including four in photogravure and one in color.

8vo. \$5.00 net. Postage 25 cents.

THIS edition has been printed direct from the original manuscript in the possession of the Fanshawe family, and Mr. H. C. Fanshawe contributes numerous notes which form a running commentary on the text.



## WILLIAM S. GILBERT

An Illustrated Biography of the Author of "The Bab Ballads" and the Comic Operas, "The Mikado," "Pinafore," etc. By EDITH A. BROWNE. 12mo. \$1.00 net. Postage 6 cents. "Of especial importance as a record of the London stage during the latter quarter of the nineteenth century."—BOSTON TRANSCRIPT.

## HERBERT BEERBOHM TREE

An Illustrated Biography of the Actor by MRS. GEORGE CRAN  
12mo. \$1.00 net. Postage 6 cents.

"Tempering her appreciation with a note of criticism, she has written a study that will not only gratify the admirers of Mr. Tree, but also form an interesting and valuable addition to the history of the modern English stage."—LONDON TRIBUNE.

**JOHN LANE CO., 110-114 West 32d Street, NEW YORK**

*Three Volumes, Super Royal Quarto*

# FRENCH ART

FROM

## WATTEAU TO PRUD'HON

TOGETHER WITH

AN INTRODUCTION and SOME STUDIES  
IN THE SOCIAL HISTORY  
OF THE PERIOD

*By* VARIOUS AUTHORS

EDITED BY

J. J. FOSTER, F.S.A.

(AUTHOR OF THE "STUARTS," "BRITISH AND FOREIGN MINIATURE PAINTERS," "THE TRUE  
PORTRAITURE OF MARY QUEEN OF SCOTS")

*Illustrated by a great number of Fine Color and Photogravure Plates  
from Pictures in the Collections of*

KING EDWARD, EMPEROR WILLIAM and OTHER REMARKABLE PRIVATE COLLECTIONS  
AND FROM THE LEADING PUBLIC GALLERIES

REPRESENTING THE FINEST WORK OF THE PRINCIPAL

PAINTERS OF THE XVIII CENTURY IN FRANCE

AUTHOR'S EDITION, *limited to 100 copies*, containing each 150 plates, of which three will be  
in color. \$150.00 net per set.

EDITION DE LUXE, *limited to 50 copies*, containing 165 plates, of which 30 will be in color;  
15 will be hand-painted, in the style of the XVIIIth Century Prints, and in addition facsimile  
reproduction of 15 colored drawings. \$300.00 net per set.

EDITION ROYALE, *limited to 10 copies*, containing 195 plates, of which 60 will be in color.  
Text and plates to be printed on Japanese vellum; 45 of the plates to be colored by hand; 30 of  
these will appear in this edition only; the majority from private collections and little known. In  
addition 15 plates of colored drawings, colored by hand, from the originals. \$1,000.00 net per set

---

**JOHN LANE CO., 110-114 West 32d Street, New York**

*In writing to advertisers, please mention The International Studio.*

PRESS OF REDFIELD BROTHERS, NEW YORK

# "TIFFANY FAVRILE GLASS"



MADE ONLY BY THE TIFFANY FURNACES  
LONG ISLAND, NEW YORK



The distinguishing name is Registered in the United States Patent Office, and is also protected by Letters Patent in Great Britain, France, Germany, Austria and Hungary.

Tiffany Favrile Glass exists under no other name.

Importers and Dealers are notified that the use of this name, wholly or partly, in connection with any glass not made by the Tiffany Furnaces, is an infringement, and all persons so using it will be prosecuted.

*Sold in New York only by  
Tiffany & Co., - Fifth Avenue  
Tiffany Studios, Madison Avenue*

## TIFFANY FURNACES

LONG ISLAND, NEW YORK

## Artists' Materials

LEFRANC & CIE; P. FOINET FILS,  
BLOCKX



### Oil Colors

And all the  
Prominent  
Makes

### Canvas

A Special Feature

## "Plasteline"

For Sculptors

### A. C. FRIEDRICHS

169 W. 57th St., New York

Largest Retail Artists' Material Dealer in the U. S.

Catalogue Free

LONDON

OSAKA

BOSTON

## YAMANAKA & CO.

254 FIFTH AVENUE,

NEW YORK

WORKS OF ART  
FROM THE FAR EAST

Rare Old Paintings and Color Prints a Specialty



## Frink's Portable Picture Reflectors

For electric light, meet all requirements for lighting pictures. Every owner of fine paintings could use one or more of these portable reflectors to advantage. The fact that so many have ordered the outfits for their friends is proof that their merits are appreciated. Height, closed, 51 inches; extended, 81 inches. The light from the reflector can be directed at any picture in the room and at any angle.

I. P. FRINK, 551 Pearl St., New York

GEO. FRINK SPENCER, Manager  
Telephone, 82 Worth

*In writing to advertisers, please mention The International Studio.*















GETTY CENTER LIBRARY



3 3125 00455 9890

