

TECHNICAL MANUAL

**AVIATION UNIT AND
INTERMEDIATE
MAINTENANCE
MANUAL**

FOLDOUTS

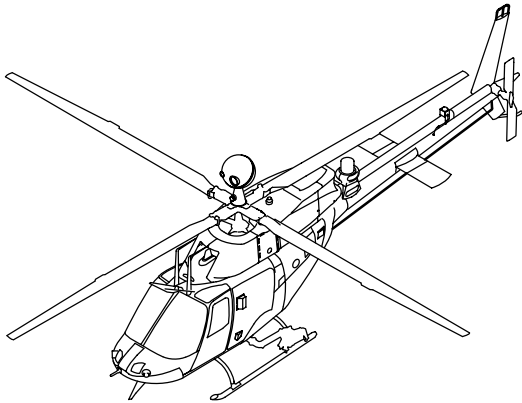

**ARMY MODEL
OH-58D HELICOPTER**

DISTRIBUTION STATEMENT A.

Approved for public release; distribution is unlimited.

*This manual together with TM 1-1520-248-23-1, TM 1-1520-248-23-2, TM 1-1520-248-23-3, TM 1-1520-248-23-4, TM 1-1520-248-23-5 and TM 1-1520-248-23-6, all dated 28 February 2000, supersedes TM 55-1520-248-23-1, TM 55-1520-248-23-2, TM 55-1520-248-23-3, TM 55-1520-248-23-4, TM 55-1520-248-23-5, TM 55-1520-248-23-6, TM 55-1520-248-23-7, TM 55-1520-248-23-8-1, TM 55-1520-248-23-8-2, and TM 55-1520-248-23-9, all dated 12 January 1988, including all changes.

THIS VOLUME IS ONE OF A SERIES OF SEVEN VOLUMES AND IS INCOMPLETE WITHOUT TM 1-1520-248-23-1, TM 1-1520-248-23-2, TM 1-1520-248-23-3, TM 1-1520-248-23-4, TM 1-1520-248-23-5, AND TM 1-1520-248-23-6.

Headquarters, Department of the Army

28 FEBRUARY 2000

WARNING

HIGH VOLTAGE

The helicopter contains high voltage and shall be electrically grounded when parked. Serious burns and electrical shock can result from contact with exposed electrical wires or connectors.

WARNING

HIGH VOLTAGE

High voltage may be stored in the ignition system after operation of the APU. This high voltage can cause injury or death.

- Do not make contact with exposed wires or connectors.
- Allow at least 5 minutes after operation of the ignition system before disconnecting or removing ignition system components.
- Turn all power switches off before making any connections or disconnections.
- Observe instructions for grounding the power cable to discharge high voltage.
- For artificial respiration, refer to FM 21-11.

WARNING

STRAY VOLTAGE

Stray voltage may exist in electronic equipment installed in the helicopter. These voltages present an explosive hazard to fuel and fuel fumes. Severe injury or death could result.

WARNING

PITOT HEAT

The pitot tube assembly is very hot during and immediately after operation requiring pitot heat. Severe burns will result if contacted by hands or other parts of the body.

WARNING**LUBRICATING OILS HAZARDOUS**

Lubricating oils DOD-L-85734, MIL-L-7808, and MIL-L-23699 contain materials hazardous to health. They can cause paralysis if swallowed. Prolonged contact with skin can cause irritation. Fire can result if oil is exposed to heat or flames.

- Use only in areas with adequate ventilation.
- Wash hands thoroughly after handling.

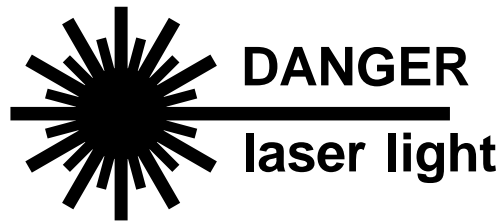
WARNING

The laser rangefinder/designator (LRF/D) is very dangerous. Looking at the laser beam or its reflection from a shiny surface can cause permanent blindness. Under noncombat conditions, the laser shall be used only in controlled areas and at times specified by a range control officer.

BATTERY ELECTROLYTE

Corrosive battery electrolyte (potassium hydroxide) requires rubber gloves, apron, and face shield when handling leaking batteries. Potassium hydroxide spilled on clothing or other material shall be washed immediately with clean water. If spilled on personnel, severe skin burns will result. Immediately start flushing the affected area with clean water and continue flushing until medical assistance arrives.

**WARNING
RADIATION HAZARD****SELF-LUMINOUS DIALS**

Self-luminous instrument dials contain radioactive materials.

- If glass is broken or case becomes unsealed, avoid personal contact. Injury to personnel could result.
- Forceps or gloves made of rubber or polyethylene shall be used to pick up contaminated material.
- Place material and gloves in a plastic bag. Seal bag and dispose of it as radioactive waste in accordance with AR 755-15 and TM 3-261.
- Repair procedure shall conform to requirements in AR 700-52.

WARNING

DRYCLEANING SOLVENT

Drycleaning solvent is flammable and toxic. It can irritate skin and cause burns.

- Use only in well-ventilated area away from heat and open flame.
- Wear rubber gloves and goggles.
- In case of contact, immediately flush skin or eyes with water for at least 15 minutes.
- Get medical attention for eyes.

WARNING

SOUND LEVEL

Sound pressure levels in this helicopter during operating conditions exceed the Surgeon General hearing conservation criteria. Hearing protection devices, such as aviator helmet or ear plugs or ear sound suppressors, are required to be worn by all personnel in and around the helicopter during its operation.

WARNING

MAIN AND TAIL ROTOR BLADES

Stay clear of turning main and tail rotor blades. Wind gusts, coast down or cyclic movement may cause the main rotor blade to flap down below the height of a person. Dangerous winds are created by the main rotor blades when blades are operated at or near top rpm. Adequate distance must be maintained from main and tail rotor blades during operation. Severe injury or death may result.

WARNING

ARMAMENT

Loaded weapons, or weapons being loaded or unloaded, shall be pointed in a direction which offers the least exposure to personnel or property in the event of accidental firing. Personnel should remain clear of hazardous area of all loaded weapons. Death or severe injury may result.

WARNING

HF ANTENNA

Ensure that HF antenna is not operating while performing maintenance. When operating, HF antenna emits infrared radiation that can cause radiation burns. If exposed to infrared radiation, seek medical aid immediately.

WARNING

ASBESTOS DUST

Avoid creating dust. Breathing asbestos dust may cause serious long-term bodily harm.

CHANGE
NO. 7

HEADQUARTERS
DEPARTMENT OF THE ARMY
WASHINGTON, D.C., 15 May 2007

Aviation Unit and Intermediate
Maintenance Manual
for
**ARMY MODEL
OH-58D HELICOPTER**

DISTRIBUTION STATEMENT A: Approved for public release; distribution is unlimited.

TM 1-1520-248-23-7, 28 February 2000, is changed as follows:

1. Remove and insert pages as indicated below. New or changed text material is indicated by a vertical bar in the margin. An illustration change is indicated by a miniature pointing hand.

Remove pages	Insert pages
A/(B blank)	A and B
FP-13/(FP-14 blank)	FP-13/(FP-14 blank)
FP-15/(FP-16 blank)	FP-15/(FP-16 blank)
FP-77/(FP-78 blank)	FP-77/(FP-78 blank)
FP-93/(FP-94 blank)	FP-93/(FP-94 blank)
FP-125/(FP-126 blank)	FP-125/(FP-126 blank)
FP-205/(FP-206 blank)	FP-205/(FP-206 blank)

2. Retain this sheet in front of manual for reference purposes.

By Order of the Secretary of the Army

Official:

GEORGE W. CASEY, JR.
General, United States Army
Chief of Staff



JOYCE E. MORROW
Administrative Assistant to the
Secretary of the Army
0709903

DISTRIBUTION:

To be distributed in accordance with Initial Distribution number 311435 (IDN) requirements for TM 1-1520-248-23-7.

CHANGE
NO. 6

HEADQUARTERS
DEPARTMENT OF THE ARMY
WASHINGTON, D.C., 14 February 2006

Aviation Unit and Intermediate
Maintenance Manual

for

**ARMY MODEL
OH-58D HELICOPTER**

DISTRIBUTION STATEMENT A: Approved for public release; distribution is unlimited.

TM 1-1520-248-23-7, 28 February 2000, is changed as follows:

1. Remove and insert pages as indicated below. New or changed text material is indicated by a vertical bar in the margin. An illustration change is indicated by a miniature pointing hand.

Remove pages	Insert pages
A/(B blank)	A/(B blank)
FP-47/(FP-48 blank)	FP-47/(FP-48 blank)
FP-141/(FP-142 blank)	FP-141/(FP-142 blank)
FP-157/(FP-158 blank)	FP-157/(FP-158 blank)

2. Retain this sheet in front of manual for reference purposes.

TM 1-1520-248-23-7
C6

By Order of the Secretary of the Army:

Official:

SANDRA R. RILEY
*Administrative Assistant to the
Secretary of the Army*
0602303

PETER J. SCHOOMAKER
*General, United States Army
Chief of Staff*

DISTRIBUTION:

To be distributed in accordance with Initial Distribution Number (IDN) 311435, requirements for TM 1-1520-248-23-7.

CHANGE
NO. 5

HEADQUARTERS
DEPARTMENT OF THE ARMY
WASHINGTON, D.C., 25 March 2005

Aviation Unit and Intermediate
Maintenance Manual

for

**ARMY MODEL
OH-58D HELICOPTER**

DISTRIBUTION STATEMENT A: Approved for public release; distribution is unlimited.

TM 1-1520-248-23-7, 28 February 2000, is changed as follows:

1. Remove and insert pages as indicated below. New or changed text material is indicated by a vertical bar in the margin. An illustration change is indicated by a miniature pointing hand.

Remove pages
A/(B blank)
FP-141/(FP-142 blank)

Insert pages
A/(B blank)
FP-141/(FP-142 blank)

2. Retain this sheet in front of manual for reference purposes.

By Order of the Secretary of the Army:

Official:

SANDRA R. RILEY
*Administrative Assistant to the
Secretary of the Army*
0503205

PETER J. SCHOOMAKER
*General, United States Army
Chief of Staff*

DISTRIBUTION:

To be distributed in accordance with Initial distribution number (IDN) 311435, requirements for
TM 1-1520-248-23-7.

CHANGE

NO. 4

HEADQUARTERS
DEPARTMENT OF THE ARMY
WASHINGTON, D.C., 15 January 2004

AVIATION UNIT AND INTERMEDIATE MAINTENANCE MANUAL

FOR ARMY MODEL OH-58D HELICOPTER

DISTRIBUTION STATEMENT A: Approved for public release; distribution is unlimited

TM 1-1520-248-23-7, 28 February 2000 is changed as follows:

1. Remove and insert pages as indicated below. New or changed text material is indicated by a vertical bar in the margin. An illustration change is indicated by a miniature pointing hand.

Remove pages	Insert pages
FP-125/(FP-126 blank)	FP-125/(FP-126 blank)
FP-169/(FP-170 blank)	FP-169/(FP-170 blank)
-----	FP-231/(FP-232 blank)
-----	FP-233/(FP-234 blank)
-----	FP-235/(FP-236 blank)

2. Retain this sheet in front of manual for reference purposes.

TM 1-1520-248-23-7
C4

By Order of the Secretary of the Army:

Official:

PETER J. SCHOOMAKER
General, United States Army
Chief of Staff

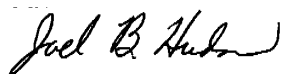

JOEL B. HUDSON
Administrative Assistant to the
Secretary of the Army
0333605

DISTRIBUTION:

To be distributed in accordance with Initial Distribution Number (IDN) 311435, requirements for TM 1-1520-248-23-7.

CHANGE

NO. 3

HEADQUARTERS
DEPARTMENT OF THE ARMY
WASHINGTON, D.C., 31 December 2002

AVIATION UNIT AND INTERMEDIATE MAINTENANCE MANUAL

FOR ARMY MODEL OH-58D HELICOPTER

DISTRIBUTION STATEMENT A: Approved for public release; distribution is unlimited

TM 1-1520-248-23-7, 28 February 2000 is changed as follows:

1. Remove and insert pages as indicated below. New or changed text material is indicated by a vertical bar in the margin. An illustration change is indicated by a miniature pointing hand.

Remove pages	Insert pages
A/(B blank)	A/(B blank)
i and ii	i and ii
FP-Index 1 and FP-Index 2	FP-Index 1 and FP-Index 2
FP-13/(FP-14 blank)	FP-13/(FP-14 blank)
FP-15/(FP-16 blank)	FP-15/(FP-16 blank)
FP-113/(FP-114 blank)	FP-113/(FP-114 blank)
---	FP-114.3/(FP-114.4 blank)
FP-125/(FP-126 blank)	FP-125/(FP-126 blank)
FP-175/(FP-176 blank)	FP-175/(FP-176 blank)
FP-229/(FP-230 blank)	FP-229/(FP-230 blank)
---	FP-230.3/(FP-230.4 blank)

2. Retain this sheet in front of manual for reference purposes.

TM 1-1520-248-23-7

C3

By Order of the Secretary of the Army:

Official:

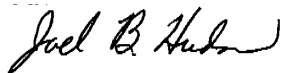

JOEL B. HUDSON

Administrative Assistant to the
Secretary of the Army

0233704

ERIC K. SHINSEKI
General, United States Army
Chief of Staff

CHANGE

NO. 2

HEADQUARTERS
DEPARTMENT OF THE ARMY
WASHINGTON, D.C., 31 December 2001

AVIATION UNIT AND INTERMEDIATE MAINTENANCE MANUAL
FOR ARMY MODEL OH-58D HELICOPTER

DISTRIBUTION STATEMENT A: Approved for public release; distribution is unlimited

TM 1-1520-248-23-7, 28 February 2000 is changed as follows:

1. Remove and insert pages as indicated below. New or changed text material is indicated by a vertical bar in the margin. An illustration change is indicated by a miniature pointing hand.

Remove pages

A/(B blank)
FP-Index 1 and FP-Index 2
FP-13/(FP-14 blank)
FP-15/(FP-16 blank)
FP-17/(FP-18 blank)
FP-19/(FP-20 blank)
FP-21/(FP-22 blank)
FP-30 blank
FP-31/(FP-32 blank)
FP-45/(FP-46 blank)

FP-125/(FP-126 blank)
FP-127/(FP-128 blank)
FP-129/(FP-130 blank)
FP-131/(FP-132 blank)
FP-137/(FP-138 blank)
FP-141/(FP-142 blank)
FP-147/(FP-148 blank)
FP-155/(FP-156 blank)

Insert pages

A/(B blank)
FP-Index 1 and FP-Index 2
FP-13/(FP-14 blank)
FP-15/(FP-16 blank)
FP-17/(FP-18 blank)
FP-19/(FP-20 blank)
FP-21/FP-22 blank
FP-29/(FP-30 blank)
FP-31/(FP-32 blank)
FP-45/(FP-46 blank)
FP-114.1/(FP-114.2 blank)
FP-125/(FP-126 blank)
FP-127/(FP-128 blank)
FP-129/(FP-130 blank)
FP-131/(FP-132 blank)
FP-137/(FP-138 blank)
FP-141/(FP-142 blank)
FP-147/(FP-148 blank)
FP-155/(FP-156 blank)
FP-230.1/(FP-230.2 blank)

2. Retain this sheet in front of manual for reference purposes.

By Order of the Secretary of the Army:

Official:

JOEL B. HUDSON
*Administrative Assistant to the
Secretary of the Army*
0134801

ERIC K. SHINSEKI
*General, United States Army
Chief of Staff*

DISTRIBUTION:

To be distributed in accordance with the initial distribution number (IDN) 311435 requirements for TM 1-1520-248-23-7.

CHANGE

NO. 1

HEADQUARTERS
DEPARTMENT OF THE ARMY
WASHINGTON, D.C., 30 November 2000

Aviation Unit and Intermediate
Maintenance Manual
For

**ARMY MODEL
OH-58D HELICOPTER**

DISTRIBUTION STATEMENT A: Approved for public release; distribution is unlimited.

TM 1-1520-248-23-7, 28 February 2000, is changed as follows:

1. Remove and insert pages as indicated below. New or changed text material is indicated by a vertical bar in the margin. An illustration change is indicated by a miniature pointing hand.

Remove pages

A/(B blank)
a through d
i through xii
xv through xxix/(xxx blank)

Insert pages

A/(B blank)
a through d
i through xii
xv through xxix/(xxx blank)

2. Retain this sheet in front of manual for reference purposes.

TM 1-1520-248-23-7
C1

By Order of the Secretary of the Army:

Official:

ERIC K. SHINSEKI
General, United States Army
Chief of Staff

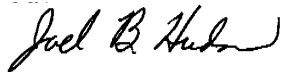

JOEL B. HUDSON
Administrative Assistant to the
Secretary of the Army
0020117

DISTRIBUTION:

To be distributed in accordance with initial distribution number (IDN) 311435, requirements for TM 1-1520-248-23-7.

LIST OF EFFECTIVE PAGES

INSERT LATEST CHANGED PAGES. DESTROY SUPERSEDED PAGES.

NOTE: ON CHANGED PAGES, A VERTICAL LINE OR OTHER CHANGE SYMBOL IN THE OUTER MARGIN OF THE PAGE INDICATES THE PORTION OF THE TEXT AFFECTED BY THE LATEST CHANGE. CHANGES TO ILLUSTRATIONS ARE INDICATED BY MINIATURE POINTING HANDS. SHADED AREAS INDICATE CHANGES TO WIRING DIAGRAMS.

Dates of issue for original and changed pages are:

Original0..... 28 February 2000	Change4..... 15 January 2004
Change1...30 November 2000	Change5..... 25 March 2005
Change2... 31 December 2001	Change6..... 14 February 2006
Change3... 31 December 2002	Change7..... 15 May 2007

Total number of pages in this volume is 178, consisting of the following:

Page No.	*Change No.	Page No.	*Change No.
Cover-1/Cover-2 blank	0	FP-39/(FP-40 blank)	0
a through d	1	FP-42/(FP-42 blank)	0
A and B	0	FP-43/(FP-44 blank)	0
i and ii	3	FP-45/(FP-46 blank)	2
iii through xii.....	1	FP-47/(FP-48 blank)	6
xiii through xiv.....	0	FP-49/(FP-50 blank)	0
xv.....	1	FP-51/(FP-52 blank)	0
xvi and xvii	0	FP-53/(FP-54 blank)	0
xviii through xxiii	1	FP-55/(FP-56 blank)	0
xxix/xxx blank	1	FP-57/(FP-58 blank)	0
FP-Index 1 and FP-Index 2.....	3	FP-59/(FP-60 blank)	0
FP-1/(FP-2 blank)	0	FP-61/(FP-62 blank)	0
FP-3/(FP-4 blank)	0	FP-63/(FP-64 blank)	0
FP-5/(FP-6 blank)	0	FP-65/(FP-66 blank)	0
FP-7/(FP-8 blank)	0	FP-67/(FP-68 blank)	0
FP-9/(FP-10 blank)	0	FP-69/(FP-70 blank)	0
FP-11/(FP-12 blank)	0	FP-71/(FP-72 blank)	0
FP-13/(FP-14 blank)	7	FP-73/(FP-74 blank)	0
FP-15/(FP-16 blank)	7	FP-75/(FP-76 blank)	0
FP-17/(FP-18 blank)	2	FP-77/(FP-78 blank)	7
FP-19/(FP-20 blank)	2	FP-79/(FP-80 blank)	0
FP-21/(FP-22 blank)	2	FP-81/(FP-82 blank)	0
FP-23/(FP-24 blank)	0	FP-83/(FP-84 blank)	0
FP-25/(FP-26 blank)	0	FP-85/(FP-86 blank)	0
FP-27/(FP-28 blank)	0	FP-87/(FP-88 blank)	0
FP-29/(FP-30 blank)	2	FP-89/(FP-90 blank)	0
FP-31/(FP-32 blank)	2	FP-91/(FP-92 blank)	0
FP-33/(FP-34 blank)	0	FP-93/(FP-94 blank)	7
FP-35/(FP-36 blank)	0	FP-95/(FP-96 blank)	0
FP-37/(FP-38 blank)	0	FP-97/(FP-98 blank)	0

*Zero in this column indicates an original page.

Page No.	*Change No.	Page No.	*Change No.
FP-99/(FP-100 blank)	0	FP-179/(FP-180 blank)	0
FP-101/(FP-102 blank)	0	FP-181/(FP-182 blank)	0
FP-103/(FP-104 blank)	0	FP-183/(FP-184 blank)	0
FP-105/(FP-106 blank)	0	FP-185/(FP-186 blank)	0
FP-107/(FP-108 blank)	0	FP-187/(FP-188 blank)	0
FP-109/(FP-110 blank)	0	FP-189/(FP-190 blank)	0
FP-111/(FP-112 blank)	0	FP-191/(FP-192 blank)	0
FP-113/(FP-114 blank)	3	FP-193/(FP-194 blank)	0
FP-114.1/(FP-114.2 blank)	2	FP-195/(FP-196 blank)	0
FP-114.3/(FP-114.4 blank)	3	FP-197/(FP-198 blank)	0
FP-115/(FP-116 blank)	0	FP-199/(FP-200 blank)	0
FP-117/(FP-118 blank)	0	FP-201/(FP-202 blank)	0
FP-119/(FP-120 blank)	0	FP-203/(FP-204 blank)	0
FP-121/(FP-122 blank)	0	FP-205/(FP-206 blank)	7
FP-123/(FP-124 blank)	0	FP-207/(FP-208 blank)	0
FP-125/(FP-126 blank)	7	FP-209/(FP-210 blank)	0
FP-127/(FP-128 blank)	2	FP-211/(FP-212 blank)	0
FP-129/(FP-130 blank)	2	FP-213/(FP-214 blank)	0
FP-131/(FP-132 blank)	2	FP-215/(FP-216 blank)	0
FP-133/(FP-134 blank)	0	FP-217/(FP-218 blank)	0
FP-135/(FP-136 blank)	0	FP-219/(FP-220 blank)	0
FP-137/(FP-138 blank)	2	FP-221/(FP-222 blank)	0
FP-139/(FP-140 blank)	0	FP-223/(FP-224 blank)	0
FP-141/(FP-142 blank)	6	FP-225/(FP-226 blank)	0
FP-143/(FP-144 blank)	0	FP-227/(FP-228 blank)	0
FP-145/(FP-146 blank)	0	FP 229/(FP-230 blank).....	3
FP-147/(FP-148 blank)	2	FP-230.1/(FP-230.2 blank)	2
FP-149/(FP-150 blank)	0	FP-230.3/(FP-230.4 blank)	3
FP-151/(FP-152 blank)	0	FP-231/(FP-232 blank)	4
FP-153/(FP-154 blank)	0	FP-233/(FP-234 blank)	4
FP-155/(FP-156 blank)	2	FP-235/(FP-236 blank)	4
FP-157/(FP-158 blank)	6		
FP-159/(FP-160 blank)	0		
FP-161/(FP-162 blank)	0		
FP-163/(FP-164 blank)	0		
FP-165/(FP-166 blank)	0		
FP-167/(FP-168 blank)	0		
FP-169/(FP-170 blank)	4		
FP-171/(FP-172 blank)	0		
FP-173/(FP-174 blank)	0		
FP-175/(FP-176 blank)	3		
FP-177/(FP-178 blank)	0		

*Zero in this column indicates an original page.

TECHNICAL MANUAL
NO. TM 1-1520-248-23

HEADQUARTERS
Department of the Army
Washington, D. C., 28 February 2000

AVIATION UNIT AND INTERMEDIATE
MAINTENANCE MANUAL
FOR ARMY MODEL
OH-58D HELICOPTER

REPORTING ERRORS AND RECOMMENDING IMPROVEMENTS

You can improve this manual. If you find any mistakes or if you know of a way to improve these procedures, please let us know. Mail your letter or DA Form 2028 (Recommended Changes to Publications and Blank Forms) located in the back of this manual, directly to: Commander, U. S. Army Aviation and Missile Command, ATTN: AMSAM-MMC-MA-NP, Redstone Arsenal, AL 35898-5000. A reply will be furnished to you. You may also provide DA Form 2028 information to AMCOM via e-mail, fax, or the World Wide Web. Our fax number is: DSN 788-6546 or Commercial 256-842-6546. Our e-mail address is 2028@redstone.army.mil.

Instructions for sending an electronic 2028 may be found at the back of this manual immediately preceding the hard copy 2028. For the World Wide Web use: <https://amcom2028.redstone.army.mil>.

HAZARDOUS MATERIAL INFORMATION

This document has been reviewed for the presence of solvents containing hazardous materials as defined by the EPCRA 302 and 313 lists. As of the base document, dated 28 February 2000, all references to solvents containing hazardous materials have been removed from this document by substitution with non-hazardous or less hazardous materials where possible.

ENGINEERING, ENVIRONMENT, AND LOGISTICS OVERSIGHT OFFICE.

DISTRIBUTION STATEMENT A. Approved for public release; distribution is unlimited.

TABLE OF CONTENTS		PAGE
	HOW TO USE THIS MANUAL	vi
VOLUME 1		
CHAPTER 1	INTRODUCTION	
Section I	General Information	1-2
Section II	Equipment Description and Data.....	1-3
Section III	Principles of Operation	1-17
Section IV	Servicing	1-56
Section V	Lubrication	1-91
Section VI	Ground Handling and Jacking	1-101

*This manual together with TM 1-1520-248-23-1, TM 1-1520-248-23-2, TM 1-1520-248-23-3, TM 1-1520-248-23-4, TM 1-1520-248-23-5 and TM 1-1520-248-23-6, all dated 28 February 2000, supersedes TM 55-1520-248-23-1, TM 55-1520-248-23-2, TM 55-1520-248-23-3, TM 55-1520-248-23-4, TM 55-1520-248-23-5, TM 55-1520-248-23-6, TM 55-1520-248-23-7, TM 55-1520-248-23-8-1, TM 55-1520-248-23-8-2 and TM 55-1520-248-23-9, all dated 12 January 1988, including all changes.

TABLE OF CONTENTS (Cont)		PAGE
Section VII	Mooring.....	1-124
Section VIII	Hoisting and Sling Loading.....	1-156
Section IX	Preventive Maintenance Inspections	1-165
Section X	Overhaul and Retirement Schedule	1-201
Section XI	Flight Safety Parts	1-203
CHAPTER 2	AIRFRAME	
Section I	Cowlings, Fairings, Access Panels, and Doors	2-2
Section II	Fuselage (Cowlings, Fairings, Access Panels, and Doors)	2-10
Section III	Tailboom.....	2-354
Section IV	Pylon.....	2-481
CHAPTER 3	ALIGHTING GEAR	
Section I	Landing Gear.....	3-1
GLOSSARY	Glossary-1
ALPHABETICAL INDEX	Index 1
VOLUME 2		
CHAPTER 4	POWERPLANT	
Section I	Engine Assembly.....	4-2
Section II	Air Induction.....	4-91
Section III	Exhaust System.....	4-128
Section IV	Engine Oil System	4-134
Section V	Ignition System	4-179
Section VI	Powerplant Controls	4-180
Section VII	Engine Mounts.....	4-228
Section VIII	Forward Firewall.....	4-272
Section IX	Aft Firewall.....	4-287
CHAPTER 5	ROTORS	
Section I	Main Rotor Hub Blade Assembly	5-2
Section II	Main Rotor Controls.....	5-161
Section III	Main Rotor Tracking and Dynamic Balancing	5-334
Section IV	Tail Rotor Hubs and Blades	5-369
Section V	Tail Rotor Pitch Change Mechanism.....	5-450
GLOSSARY	Glossary-1
ALPHABETICAL INDEX	Index 1
VOLUME 3		
CHAPTER 6	DRIVE TRAIN SYSTEM	
Section I	Serviceability Checks	6-2
Section II	Engine to Transmission Driveshaft.....	6-23
Section III	Transmission	6-31
Section IV	Standpipe Electrical Assembly, Torquemeter System, and Main Rotor Mast Assembly	6-95
Section V	Freewheeling Unit.....	6-187
Section VI	Tail Rotor Driveshafts	6-239
Section VII	Tail Rotor Gearbox	6-327
Section VIII	Oil System	6-369

TABLE OF CONTENTS (Cont)		PAGE
CHAPTER 7	HYDRAULIC SYSTEM	
Section I	Actuators	7-2
Section II	Hydraulic System Bleeding	7-36
Section III	Hydraulic Filter Assemblies	7-39
Section IV	Hydraulic Hoses, Lines, Tubes, Fittings, and Quick-Disconnects	7-47
Section V	Pressure Switch, Manifolds, and Relief Valve	7-61
Section VI	Hydraulic Solenoid Valve	7-75
Section VII	Hydraulic Reservoir	7-86
Section VIII	Hydraulic Pump	7-108
CHAPTER 8	INSTRUMENT SYSTEMS	
Section I	Engine, Rotor and Transmission Instruments	8-2
Section II	Flight Instruments	8-45
Section III	Pitot-Static Instrument and Air Data Systems	8-59
Section IV	Navigation Instruments	8-77
Section V	Miscellaneous Instruments	8-77
GLOSSARY	Glossary 1
ALPHABETICAL INDEX	Index 1
 VOLUME 4		
CHAPTER 9	ELECTRICAL SYSTEM	
Section I	Avionics Cooling System	9-2
Section II	Avionic System Mounts	9-19
Section III	Direct Current Power and Distribution System	9-44
Section IV	Alternating Current Power and Distribution System	9-98
Section V	Lighting System	9-131
Section VI	Miscellaneous Electrical Equipment	9-175
Section VII	Powerplant and Transmission Electrical Equipment	9-405
Section VIII	Armament Electrical Equipment	9-440
CHAPTER 10	FUEL SYSTEM	
Section I	Fuel System Components	10-2
Section II	Fuel Cell	10-62
GLOSSARY	Glossary 1
ALPHABETICAL INDEX	Index 1
 VOLUME 5		
CHAPTER 11	FLIGHT CONTROLS	
Section I	Rigging	11-2
Section II	Collective Controls	11-55
Section III	Cyclic Control System	11-209
Section IV	Directional Controls	11-417
Section V	Component Inspection	11-521

TABLE OF CONTENTS (Cont)

PAGE

CHAPTER 12	ENVIRONMENTAL CONTROL SYSTEMS	
Section I	Heating System	12-2
Section II	Ventilating System	12-38
CHAPTER 13	MISSION EQUIPMENT	
Section I	Cargo Hook Suspension Assembly	13-2
Section II	Rapid Deployment	13-24
Section III	Rescue Ladder	13-58
CHAPTER 14	EMERGENCY EQUIPMENT	
Section I	Miscellaneous Emergency Equipment	14-2
GLOSSARY	Glossary 1
ALPHABETICAL INDEX	Index 1
 VOLUME 6		
APPENDIX A	REFERENCES	
APPENDIX B	MAINTENANCE ALLOCATION CHART (MAC)	
Section I	Introduction	B-1
Section II	Maintenance Allocation Chart	B-4
Section III	Tool and Test Equipment Requirements	B-26
Section IV	Remarks	B-38
APPENDIX C	HELICOPTER INVENTORY MASTER GUIDE	
APPENDIX D	EXPENDABLE AND DURABLE ITEMS LIST	
APPENDIX E	STORAGE OF HELICOPTER	
Section I	General Information	E-1
Section II	Flyable Storage	E-4
Section III	Short Term Storage	E-8
Section IV	Intermediate Storage	E-17
APPENDIX F	WIRING DATA	
APPENDIX G	WEIGHT AND BALANCE	
Section I	General Information	G-1
Section II	Instructions for Use of Forms and Charts	G-2
Section III	Weighing Instructions	G-26

TABLE OF CONTENTS (Cont)

PAGE

APPENDIX H	ILLUSTRATED LIST OF MANUFACTURED ITEMS (AVUM, AVIM)	
APPENDIX J	RESERVED FOR FUTURE USE	
APPENDIX K	RESERVED FOR FUTURE USE	
APPENDIX L	RESERVED FOR FUTURE USE	
APPENDIX M	ELECTRICAL BONDING PROCEDURES	
Section I	Introduction	M-1
Section II	Equipment Requirements	M-2
Section III	Resistance Requirements	M-2
Section IV	Procedures	M-3
Section V	Test	M-9
APPENDIX N	RESERVED FOR FUTURE USE	
APPENDIX P	STANDARD TORQUE VALUES	
APPENDIX Q	CORROSION CONTROL	
Section I	Introduction	Q-1
Section II	Inspection and Corrosion Prone Areas	Q-2
Section III	Preventive Maintenance	Q-2
Section IV	Processes and Equipment Requirements	Q-4
Section V	Corrosion Prone Areas	Q-4
APPENDIX R	RESERVED FOR FUTURE USE	
GLOSSARY	Glossary 1
ALPHABETICAL INDEX	Index 1
VOLUME 7		
FOLDOUTS	FP-1

HOW TO USE THIS MANUAL

1. GENERAL

To get the job done correctly, you must be able to find all the information you need. Knowing how to use this manual is the key. You should know what is in this manual, how the manual is organized, and how to use it.

2. ORGANIZATION

- a. The complete OH-58D/OH-58D(R) Kiowa Warrior helicopter (AVUM/AVIM) maintenance manual consists of a set of seven volumes. These volumes are numbered as follows: TM 1-1520-248-23-1 through TM 1-1520-248-23-7.
- b. Volumes are made up of chapters. Each chapter is numbered in Arabic numerals (1, 2, 3, etc.). Each chapter has maintenance information on a particular helicopter system.
- c. Chapters are broken down into sections. Sections are numbered in Roman numerals (I, II, III, etc.).
- d. Sections are made up of paragraphs and tasks. The first three sections of Chapter 1 are made up of paragraphs that describe and locate the helicopter systems and components. Other sections throughout the manual are made up primarily of tasks, but all sections contain introductory paragraphs that describe the section contents. Sections cover major parts of a system.
- e. Tasks are detailed descriptions of maintenance procedures. Some tasks are brief. Some are several pages long.
- f. The title of each task contains the name of the component followed by the type of operation that is being described, e.g., Removal, Cleaning, Inspection, Repair, Installation, and others as applicable.
- g. A task starts with an initial setup (content detailed in paragraph 8.) which is followed by a step-by-step procedure on how to perform the task correctly. The steps in the procedures have illustrations to help make things clear.
- h. The words “INSPECT” or “INSPECT” may be seen in a task. “INSPECT” means that the repairer shall stop and check the component. “INSPECT” means that a Technical Inspector (TI) is required. Do not go beyond that point in the procedure until the TI has completed his inspection.
- i. If applicable, a paragraph at the end of a task called “FOLLOW-ON MAINTENANCE” may be seen. The steps listed will be required to place the helicopter in a flyable state following the completion of the maintenance task.
- j. Operational checks and troubleshooting procedures are contained in the three-volume TM 1-1520-248-T manual. A reference to TM 1-1520-248-T will be made if an operational check must be performed to ensure serviceability.

3. PARAGRAPH NUMBERING

- a. Paragraph numbers are assigned to each major information subject.
- b. Paragraphs are individually numbered by chapter and sequence.

4. TASK NUMBERING

Task numbers are in three parts. The first is the chapter number. The second is the section number in that chapter. The third number is the task's actual sequence in the section. Each number is separated by a (-) as shown in the example:

HOW TO USE THIS MANUAL — continued

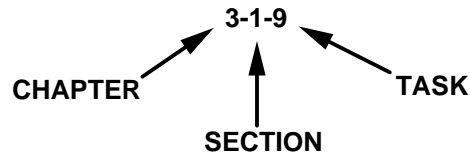

Task numbers are the most important numbers in the manual. Always use the task number, NOT the page number, to find information.

5. PAGE NUMBERING

Except for front matter (all material that precedes Chapter 1), appendices, glossary, alphabetical index, and foldouts, all page numbering is by chapters. The first number is the number of the chapter; the second number is the number of the page in that chapter. The numbers are separated by a dash as shown in the example:

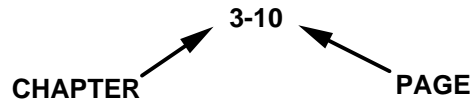

6. MANUAL INDEX

- a. The alphabetical index for the entire manual is located at the end of each volume of volumes 1 through 6. The index lists all task titles and certain key paragraphs of non-task text in alphabetical order. After you find the title in the index, it tells the task number or paragraph number of that task or text. For example, if you need information on the wire cutter, go to the "C" section of the index and look under "Cutter."

There you will find:

Cutter (Rapid Deployment), Lower Wire — Removal/Installation 2-2-60

The index tells that the wire cutter information for the lower wire cutter is in Chapter 2, section 2, task 60.

- b. You can find your task in the index, even if you only know a single word in the title. In the sample title above you could also find your tasks by looking under "Wire". Examples:

Wire Cutter (Rapid Deployment), Lower — Removal/Installation 2-2-60

Or, you could look under "Lower":

Lower Wire Cutter (Rapid Deployment) — Removal/Installation 2-2-60

In using the manual index, many similar task titles will be encountered. Some titles are similar though in different systems. This is true with shafts, brackets, supports, bearings, etc. The index will provide the name of the correct system to help you avoid going to the wrong paragraph/task.

- c. Any task can be located in the way described. If you know the name, job, part, assembly, procedure, description, etc., you can use one of the words to find the paragraph number in the index.

7. GLOSSARY

- a. A glossary of words used throughout the manual is located just before the alphabetical index in each volume of volumes 1 through 6. Section I of the glossary is the list of abbreviations and acronyms. Abbreviations are shortened terms for words. Acronyms are shortened terms for several words and use only the first letter of each of the words. Abbreviations and acronyms are defined where first used. The glossary provides a good place to check if there is any doubt.

HOW TO USE THIS MANUAL — continued

- b. Section II of the glossary contains definitions of unusual terms that appear in the manual. Many words have more than one meaning. A word that has a certain meaning in everyday language could have a different meaning for the helicopter. This is the reason for the definitions. If you see an unfamiliar word in the manual, check the list of definitions.
- c. Review the glossary periodically to ensure familiarity with the abbreviations, acronyms, and unusual terms.

8. INITIAL SETUP

The first page of each maintenance task in the manual contains the initial setup. Always check the initial setup before starting a task on the helicopter. The initial setup contains information you must know. **DON'T START A TASK UNTIL:**

- You understand the task
- You understand what you are to do
- You understand what is needed to do the work
- You have the things you need.

An example initial setup is shown below. Not all tasks have the headings shown.

Each part of the initial setup is explained by the following subparagraphs (a. through h.). Each subparagraph describes initial setup entries in order of their appearance in the example.

- a. **Title:** The title in the upper border contains the chapter/section/task number and title of the task as listed in the index. The task is performed at the intermediate level if (AVIM) appears in the title.
- b. **This Task Covers:** This entry appears in the border below the title. The task may require one or more operations (such as removal and installation).
- c. **Applicable Configurations:** This entry specifies the model or models for which the task is used, i.e., OH-58D, OH-58D(R), or All.
- d. **Tools:** This heading identifies the list of tool kit(s) by MOS(s). The tools in the kit(s) and any others listed will be all that are required to perform the task. Tasks requiring tools other than those in this tool kit are considered SPECIAL TOOLS. Special tools could be: (1) tools from the shop set; (2) tools from the kits of other MOSs, or (3) tools made especially for the OH-58D helicopter. Special tools will be listed in addition to MOS tool kits when needed. Tool kits and special tools have an item number assigned to them and are located in Appendix B. Appendix B contains a "Tools and Test Equipment Requirements" listing. Each item listed has an Equipment Reference Code. This code is used to clearly identify a tool or item of test equipment, e.g., (B127). It is acceptable to use a torque wrench other than that which is listed as long as the torque range is the same. Example: 1/4 - inch drive torque wrench **30 INCH-POUNDS to 150 INCH-POUNDS** or 3/8 - inch drive torque wrench **30 INCH-POUNDS to 150 INCH-POUNDS**. If a tool or a part will have to be made, it is listed in an index in Appendix H. The index will identify the tool or part by name or part number, and a figure number in Appendix H will be referenced. All information required to construct a part or tool is provided in the figure.

HOW TO USE THIS MANUAL — continued

INITIAL SETUP EXAMPLE

9-6-1. WEIGHT-ON-GEAR SWITCH (RAPID DEPLOYMENT LANDING GEAR) — REMOVAL/INSTALLATION

This task covers: Removal and Installation (On Helicopter)

INITIAL SETUP

Applicable Configurations:
All

Personnel Required:
67S Scout Helicopter Technical Inspection (TI) ■
68F Aircraft Electrician

Tools:
Electrical Repairer Tool Kit (B177)

Material:
Sealing Compound (D179)
Lockwire (D132)
Rubber Gloves (D111)

References:
TM 11-1520-248-23

Equipment Condition:
Helicopter Safed (Task 1-6-7)
Helicopter on Jacks (Task 1-6-8)

e. **Material:** This heading identifies the list of materials needed to complete the task. Most materials cannot be used on the helicopter a second time; they are expendable. Expendable materials are items such as solvent, grease, oil, hydraulic fluid, etc.

(1) Each expendable has an item number assigned to it and is located in Appendix D. The item number is placed in parentheses following the item name on the initial setup page. A typical example of an expendable item is:

Lockwire (D132)

See the expendable and durable item list in Appendix D for more information about expendable and durable materials.

(2) Some parts are also expendable.

(3) It may be necessary to use a part as a tool to do a step in a task. These parts do not appear in TM 1-1520-248-23P. A typical example would be when a bolt is used to temporarily hold an assembly in place or to align two pieces of material to be fastened.

f. **Personnel Required:** This heading lists the people required to perform the task. It also tells the MOS of each person and the number of persons required. For example:

67S	Scout Helicopter Repairer (2)	■
67S	Scout Helicopter Technical Inspector (TI)	

This listing would indicate that two 67S repairers and a 67S technical inspector will be needed to complete the task.

IF YOUR MOS IS NOT LISTED IN THE PERSONNEL REQUIRED COLUMN IN THE INITIAL SETUP, CHECK WITH YOUR MAINTENANCE SUPERVISOR FIRST BEFORE STARTING THE TASK.

g. **References:** This heading identifies the list of other technical manuals (TMs) needed to complete a task. The steps in the task will tell you when you must refer to another TM.

HOW TO USE THIS MANUAL — continued

- h. **Equipment Condition:** This heading identifies the list of tasks or parts of tasks that must be accomplished before starting a task. It may require an operation such as jacking the helicopter, or just the tailboom; or removing parts, assemblies, etc. These operations are described in other tasks or technical manuals. The paragraphs or TMs that describe how to do these operations are referenced here. If the job is to be done on the helicopter, the statement “Helicopter Safed” will appear here. The reference will be to Task 1-6-7 where armament safing is described. It is essential that equipment conditions listed in a particular task be followed in sequence so that required conditions are not missed and all required tasks are reviewed prior to start of maintenance.

9. WARNINGS, CAUTIONS AND NOTES

The warnings used in this manual may be in text or icon format. Text warnings are used to describe hazardous situations, and icons are for hazardous materials and certain operations where defined.

Icon warnings are pictorial images which may be used in place of words. The safety summary sheet, which is located immediately after the title page, explains in detail what each icon means.

WARNING AND CAUTION STATEMENTS

WARNING and CAUTION statements are used prior to operating or maintenance procedures, practices, or conditions considered essential to the protection of personnel (WARNING) or equipment and property (CAUTION). A WARNING or CAUTION will apply each time the related step is repeated. Prior to starting any task, the WARNINGS or CAUTIONS included in the text for that task will be reviewed and understood. Refer to the materials list figure at the beginning of the appropriate manual section for material used during maintenance of this equipment. The detailed warnings for hazardous material and operations are listed separately in the safety summary as “Hazardous Materials and Operations Icons”.

HAZARDOUS MATERIALS

This publication describes physical and chemical processes which may require the use of chemicals, solvents, paints, or other commercially available material. The user of this publication should obtain the material safety data sheets (Occupational Safety and Health Administration (OSHA) Form 20 or equivalent) from the manufacturers or suppliers of materials to be used. The user must become completely familiar with the manufacturer/supplier information and adhere to the procedures, recommendations, warnings, and cautions of the manufacturer/supplier for the safe use, handling, storage, and disposal of these materials.

HAZARDOUS MATERIALS WARNINGS

Warnings for hazardous material in this manual are designed to warn personnel of hazards associated with such items when they come in contact with them during actual use. For each hazardous material used, material safety data sheet (MSDS) is required to be provided and available for review by the users. Consult your local safety and health staff concerning any questions on hazardous chemicals, MSDSs, personnel protective equipment requirements, and appropriate handling and emergency procedures.

This Safety Summary gives the complete warnings for hazardous material used in this manual.

NOTES

Notes tell something extra or special a person must know to do the task. They can appear before or after the item they tell about. Notes shall be read and remembered when working on the helicopter.

10. USE OF SHALL, WILL, SHOULD, AND MAY

Within this technical manual the word shall is used to indicate a mandatory requirement. The word will is used to express a declaration of purpose or futurity. The word should is used to indicate a desired result

HOW TO USE THIS MANUAL — continued

or a nonmandatory but preferred method of accomplishment. The word may is used to indicate an acceptable method of accomplishment.

11. TORQUING INFORMATION

- a. An inspector shall be present to verify all torques specified in this manual.
- b. Each hardware fastener (except types used in sheet metal work) is assigned an applied torque.
- c. There are two types of applied torques. They are: special torques and standard torques.
 - (1) Special torques differ from standard torques as determined by engineers who look at each application. Special torques are given in bold type. Torque wrenches and adapters to be used when a special torque is given are listed under Tools in the initial setup.
 - (2) Standard torques are listed in Appendix P. Standard torques not listed in Appendix P can be found in TM 1-1500-204-23. Standard torque applies to all fasteners for which a special torque is not specified.

12. INSPECTION INFORMATION

General inspection information is in the front of each chapter or section for the equipment covered in that chapter or section. Inspection criteria peculiar to a specific part, assembly, or component are in the inspection steps of the removal/installation task for that part, assembly, or component.

13. GENERAL MAINTENANCE INFORMATION

The following are considered standard maintenance practices. Instructions about these practices are not normally included in maintenance procedure task steps.

- a. Lines shall be tagged before they are disconnected. Tubes and parts shall be capped or plugged when they are disconnected.
- b. Used preformed packings, retainers, gaskets, cotter pins, lockwashers, etc., shall be discarded. New parts shall be installed.
- c. Packings shall be lubricated before installation. Specific instructions are provided in each maintenance procedure.
- d. Tubes and related parts shall be tied out of the way with twine, not lockwire.
- e. Disassembly procedures reflect disassembly needed to support total authorized repair. You may not need to disassemble a part as far as described in the task. Follow the steps to disassemble as far as needed to repair/replace worn or damaged parts.
- f. Before a component or the disassembled parts of a component are inspected, they are cleaned as required.
- g. Components and mating surface areas shall be inspected for serviceable condition before installation.
- h. Guide lines shall be used when any item is hoisted overhead.
- i. When a nut is tightened or loosened on a bolt, the bolt head shall be held with a wrench.
- j. When a coupling nut on a line is tightened or loosened, the mating fitting shall be held with a wrench.
- k. A special torque shall be cited when a direction to torque is given. A standard torque is required when no specific torque is given. Standard torque information is located in Appendix P of this manual and TM 1-1500-204-23.

HOW TO USE THIS MANUAL — continued

- l. When torquing hardware, observe compliance with drag torque as required. To determine drag torque, thread nut onto screw or bolt until at least two threads protrude. The nut shall not contact the mating part. The torque necessary to begin turning the nut is the drag torque. Drag torque is explained in more detail in TM 1-1500-204-23.
- m. Chafing is a condition which occurs when two or more components contact each other in such a manner that friction and consequent wear occur. This condition is not acceptable. Proper routing, clamping, and component installation are required.

14. ELECTRICAL WIRING AND CABLING

This technical manual contains removal and installation procedures for wiring harness/cable assemblies that are permanently installed in the helicopter. Wiring harnesses/cable assemblies that can or are normally removed with avionic/electronic equipment are contained in TM 11-1520-248-23. Wiring harnesses/cable assemblies applicable to armament systems are contained in TM 9-1090-214-23&P where these wiring harnesses/cable assemblies are external to the helicopter fuselage.

15. GENERAL REFERENCES

- a. Refer to TM 55-1500-323-24 for all electrical tasks of a general nature not peculiar to the OH-58D helicopter.
- b. Refer to TM 1-1500-204-23 for mechanical tasks of a general nature not peculiar to the OH-58D helicopter.
- c. Refer to TM 1-1520-266-23 for approved nondestructive inspection methods.

16. APPENDICES

The organization and content of Appendices to this manual are provided for reference as required during performance of maintenance tasks.

- Appendix A is a list of References.
- Appendix B is the Maintenance Allocation Chart and Tool and Test Equipment Requirements List.
- Appendix C is the Helicopter Inventory Master Guide.
- Appendix D is an Expendable Supplies and Materials List.
- Appendix E describes Storage of Helicopter.
- Appendix F is Wiring Data.
- Appendix G provides Weight and Balance Data.
- Appendix H provides Locally Manufactured Items Data.
- Appendices J, K and L are reserved for future use.
- Appendix M provides Electrical Bonding Procedures.
- Appendix N is reserved for future use.
- Appendix P provides Standard Torque Values.
- Appendix Q provides Corrosion Control Information.
- Appendix R is reserved for future use.

Table 1. Organization and Content of Appendix A

Organization	Content
References List	List of additional manuals required for use by maintenance personnel in the performance of their duties.

HOW TO USE THIS MANUAL — continued

Table 2. Organization and Content of Appendix B

Organization	Content
Section I	Introduction to Maintenance Allocation Chart.
Section II	Maintenance Allocation Chart.
Section III	Tool and Test Equipment Requirements. Tools and test equipment, including special tools and common tool sets required for each maintenance function as referenced in Maintenance Allocation Chart and individual tasks.
Section IV	List of remarks for each maintenance function as referenced in the Maintenance Allocation Chart.

Table 3. Organization and Content of Appendix C

Organization	Content
Helicopter Inventory Master Guide	Paragraph that provides general information.
Security	Normally, helicopter inventory records are not classified.
Inventoriable Items	List of mission equipment, loose equipment, modification kits, and special environment equipment.
Periods of Inventory	Guidelines on the events and frequency of events that mandate an inventory accounting of listed items.

Table 4. Organization and Content of Appendix D

Organization	Content
Scope	Description of purpose and limits for the Appendix.
Explanation of Columns	Description of the tabular layout by function. Expendable Supplies and Material List in both numerical and alphabetical order.

HOW TO USE THIS MANUAL — continued**Table 5. Organization and Content of Appendix E**

Organization	Content
Section I	General Information including components involved in accidents, Requirements, Storage Categories, Procedures, and Inspection.
Section II	Description of procedures required to store the OH-58D in a flyable state.
Section III	Description of procedures required to store the OH-58D for a short term.
Section IV	Description of procedures required to store the OH-58D for an intermediate period of time.

Table 6. Organization and Content of Appendix F

Organization	Content
Wiring Diagrams	Essential general wiring information about electrical systems and circuits.
Equipment List	Electrical equipment items listed by reference designator, and their nomenclature, location, and access in tabular form.
Wire Repair and Replacement	Wiring repair and replacement data including wire sizes and part numbers, wire construction, marking, soldering, support, and stripping.
Routing and Clamping	Diagrams of OH-58D wire bundle clamping arrangements.

Table 7. Organization and Content of Appendix G

Organization	Content
Section I	General information required for intermediate maintenance personnel to perform their phase of weight and balance control.
Section II	Instruction on proper use of forms and charts required for calculations and documentation of weight and balance data.
Section III	Specific instructions for properly weighing the OH-58D helicopter.

HOW TO USE THIS MANUAL — continued

Table 8. Organization and Content of Appendix H

Organization	Content
Part Number Index	Part numbers arranged in alphanumeric order along with figure reference for each part number.
Illustrations of Locally Manufactured Items	Illustrations of locally manufactured items in sufficient detail to enable their construction.

Appendices J, K and L are reserved for future use.

Table 9. Organization and Content of Appendix M

Organization	Content
Section I	Introduction and general information including intended purpose, definitions, electrical bonding classes, and tools.
Section II	Description of tools required.
Section III	Resistance requirements for each class of bonding.
Section IV	Surface preparation and methods of bonding.
Section V	Testing of completed bonds.

Appendix N is reserved for future use.

Table 10. Organization and Content of Appendix P

Organization	Content
Introduction	General information about the Appendix.
Torque Values	General and specific information about torquing procedures including Torque Tables.
Selection and Use of Torque Wrench	Methods of choosing torque wrenches and procedures and calculations.

HOW TO USE THIS MANUAL — continued

Table 11. Organization and Content of Appendix Q

Organization	Content
Section I	An introduction that explains purpose of Appendix and defines corrosion.
Section II	Explanation of Inspection and Corrosion Prone Areas as to Purpose of Inspection and Responsibilities for Corrosion Control.
Section III	Preventive Maintenance described in terms of Prevention and Preservation.
Section IV	Required references to appropriate manuals for Corrosion Control Processes and Equipment Requirements.
Section V	Description of Corrosion Prone Areas. Provision of and reference to Inspection and Repair Procedures. Data is both tabular and pictorial.

Appendix R is reserved for future use.

SAFETY SUMMARY

1. GENERAL SAFETY INSTRUCTIONS.

This manual contains procedures which, if not followed properly, can cause injury or long-term health hazards to personnel. This safety summary includes general safety precautions and instructions that must be understood and applied during operation and maintenance to ensure personnel safety. Prior to performing any task, the WARNINGS included in that task shall be reviewed and understood.

2. WARNINGS.

WARNINGS are used in this manual to highlight operating or maintenance procedures, practices, conditions, statements which are considered essential to protection of personnel (WARNING). WARNINGS immediately precede the step or procedure to which they apply. WARNINGS consist of four parts: heading (WARNING or icon [see HAZARDOUS MATERIALS WARNINGS]), or statement of the hazard, maintenance precautions, and possible result if disregarded.

WARNING

Highlights an essential operating or maintenance procedure, practice, condition, statement, etc., which, if not strictly observed, could result in injury or long-term health hazards to personnel.

3. HAZARDOUS MATERIALS WARNINGS.

Hazardous Materials Warnings in this manual are provided through use of the Hazard Symbols listed below. Consult the HAZARDOUS MATERIALS DESCRIPTION below or Material Safety Data Sheets (MSDS) (Occupational Safety and Health Administration (OSHA) Form 20 or equivalent) for specific information on hazards, effects, and protective equipment requirements. If you do not have an MSDS for the material involved, contact your supervisor or the base Safety or Bioenvironmental Engineering Office.

3.1 Hazardous Materials and Operations Icons. Icons are used in this manual to identify dangers associated with hazardous materials and certain conditions. The symbols used and their definitions are as follows.



The abstract bug symbol shows that a material may contain bacteria or viruses that present a danger to your life or health.



The symbol of drops of a liquid onto a hand shows that the material will cause burns or irritation of human skin or tissue.

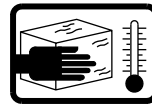

The symbol of a hand in a block of ice shows that the material is extremely cold and can injure human skin or tissue.



The rapidly expanding symbol shows that the material may explode if subjected to high temperatures, sources of ignition, or high pressure.



The symbol of a person wearing goggles shows that the material will injure your eyes.



The symbol of a flame shows that a material can ignite and burn you.



The symbol of a skull and crossbones shows that a material is poisonous or is a danger to life.



The symbol of three circular wedges shows that the material emits radioactive energy and can injure human tissue or organs.



The symbol of a human figure in a cloud shows that vapors of a material present a danger to your life or health.



The symbol of a lightning bolt shows that you may contact voltage and current that may present a danger to your life or health.



To avoid violent reactions that can cause personal injury, always pour acid into water, never water into acid.



The symbol of a head with the ear highlighted shows that the noise level may injure your hearing.

3.2 Hazardous Materials Description. The following hazardous materials are used in this manual. Each icon represents certain hazards as described above. Beneath the icons is the hazardous material name. Below the icons and material name is a description of the hazardous material. Only the icons and material name are used in the text of the manual. If a full description of the hazardous material is required while performing procedures in this manual, use the material name to locate the appropriate description below.



ACETONE

Acetone is flammable; do not use near open flames, near welding areas, or on hot surfaces. Do not smoke while using acetone, and do not use it where others are smoking. Prolonged inhalation of vapor can irritate eyes and mucous membranes and can cause dizziness and headache. If any liquid contacts skin, wash with soap and water. Immediately remove solvent-saturated clothing. If vapors cause drowsiness, go to fresh air. In all cases get immediate medical attention. When handling large quantities of liquid (more than a gallon), use at air-exhausted workbench. Wear approved gloves. Store solvent and dispose of liquid-soaked rags in approved metal safety container. Metal containers of solvent must be grounded to maintain electrical continuity.



ACRYLIC LACQUER

Acrylic lacquer is flammable. Keep away from open flames, sparks, and heat. Overexposure may cause coma, headache, narcotic effect, confusion, depression, irritation of skin, eyes, and respiratory system. Remove contaminated clothing. Wipe off with towel or cloth. Remove remainder with

mineral spirits or lacquer remover and thoroughly wash skin area with soap and water. Immediately flush eyes with water for 15 minutes. If inhaled, move to fresh air. If breathing has stopped perform resuscitation. In all cases get immediate medical attention. When working with acrylic lacquer, wear approved protective gloves, goggles or safety glasses, protective clothing, and approved respirator. Use in a well-ventilated area.



ADHESION PROMOTER

Adhesion promoter is flammable; keep away from sparks, flames, and non-explosion proof devices. Inhalation may cause nose and throat irritation, headache, drowsiness, weakness, or exhaustion. Prolonged or repeated skin contact may cause irritation. Vapor and liquid may cause eye irritation. Ingestion may cause intoxication and gastrointestinal irritation. Prolonged overexposure to ethanol can have adverse effects on liver. If inhaled, remove to fresh air. If not breathing give artificial respiration. If breathing is difficult, give oxygen. Remove contaminated clothing and wash with soap and water. Flush eyes with plenty of water for 15 minutes while holding eyelids open. If ingested, dilute with one to two glasses of water or milk. Induce vomiting by sticking finger down throat. In all cases, get immediate medical attention. When working with adhesion promoter, wear approved respirator, goggles, and rubber gloves. Work in well-ventilated area.



ADHESIVE, EA934NA

Adhesive can cause allergic reaction, skin sensitization, or gastrointestinal irritation. Contact with eyes can cause severe burns. Wash skin immediately with soap and water. Flush eyes with water for at least 15 minutes. Get immediate medical attention in event of eye contact with adhesive. Wash contaminated clothing before reuse. Wear approved respirator in closed area. Work in well-ventilated area using approved rubber gloves and safety glasses or goggles.

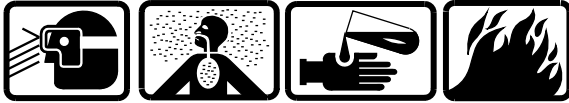

**ADHESIVE, MMM-A-1617,
TYPE I, II, OR III**

Adhesive may cause irritation to skin, eyes, and respiratory system. Thoroughly wash skin area with soap and water and immediately flush eyes with water for 15 minutes. In all cases get immediate medical attention. When working with adhesive, wear approved protective gloves, goggles or faceshield, and respirator approved for organic solvents. Use in a well-ventilated area away from open flame, spark sources, and heat.



ADHESIVE PRIMER

Adhesive primer is flammable and its vapor is explosive. Keep away from heat, open flame or other sources of ignition. Inhalation will cause irritation to the respiratory tract. Symptoms are headache, nausea, dizziness, and drowsiness. Move to fresh air and administer oxygen. If skin or eyes are affected wash skin with soap and water and flush eyes with water for 15 minutes. In all cases get immediate medical attention. When working with adhesive primer, wear approved respirator, rubber gloves and splashproof goggles and faceshield. Work in well-ventilated area.



ADHESIVE VAPORS

Adhesive vapors may cause irritation of eyes, nose, and respiratory system. Eye and skin contact with material may cause irritation. If ingested, may cause gastric distress. Flush eyes with water for 15 minutes. Wash skin with soap and water. If inhaled, move to fresh air. In all cases get immediate medical attention. Work in a well-ventilated area. Wear approved gloves and safety glasses.



ANTI-ICING/DEICING FLUID

Anti-icing/Deicing fluid contains diluted alcohol. Alcohol is flammable; do not use near open flames, near welding areas, or on hot surfaces. Do not use while smoking or while others are smoking. Inhalation of vapors can cause drowsiness, dizziness, and headache. If vapors cause drowsiness, go to fresh air. Contact with skin may cause irritation. If liquid touches skin or eyes, flush thoroughly with water. Remove contaminated clothing.



ANTISEIZE COMPOUND

Antiseize compound is flammable; do not use near open flames, welding areas, or on hot surfaces. When decomposed by heating, toxic gases are released. Do not use while smoking or when others are smoking. Liquid can cause severe skin and eye irritation. Inhalation of vapor can cause drowsiness, headache and unconsciousness. Wash affected skin with soap and water. Flush eyes with water for at least 15 minutes. If drowsiness occurs, go to fresh air. Seek medical attention if overexposed. Use approved respirator, gloves, and goggles for prolonged use. Dispose of liquid soaked rags in an approved, grounded metal safety container.



**CHEMICAL CONVERSION
MATERIALS**

Chemical conversion materials are strongly oxidizing and are a fire hazard in contact with acid, reducing agents, and combustible and

readily oxidizing materials; separate storage is mandatory. Thoroughly rinse rags and containers contaminated with chemical conversion materials and dispose of in a fireproof container. Contact with skin and eyes can cause burns. Breathing of dust or vapors can cause ulceration of mucous membranes. Thoroughly wash skin area with soap and water and immediately flush eyes with water for 15 minutes. If ingested, drink milk of magnesia, aluminum hydroxide gel, or lime water followed by large amounts of water. In all cases get immediate medical attention. Wash contaminated clothing before wearing. When working with chemical conversion materials, wear approved respirator, rubber apron, gloves, and goggles or faceshield in a well-ventilated area away from heat, open flames or sparks. Follow approved toxic waste disposal procedures. Read manufacturers label for additional information.



CHROMIC ACID

Chromic acid is highly reactive; do not mix with organic or oxidizable materials such as paper or wood. When mixing solutions, add acid slowly to water, not water to acid. Any contact with skin, or inhalation of vapors and powder can irritate skin and can cause skin ulcers. Repeated or prolonged exposure can cause permanent injury. If any liquid or powder contacts skin, flush affected area with water, and immediately change contaminated clothing. If skin ulcers appear, get immediate medical attention. When handling dry material or solution at air-exhausted workbench, wear approved gloves, apron, and goggles. When handling dry material or solution at unexhausted workbench, wear approved respirator, gloves, apron, and long sleeves.



CLEANING COMPOUND

Aircraft cleaning compound is flammable and is toxic to the skin by absorption and to the liver and kidneys. It can cause irritation of the eyes and respiratory system, skin irritation and headache. Thoroughly wash skin area with water and immediately flush eyes with water for 15 minutes. If ingested, do not induce vomiting. In all cases

get immediate medical attention. When working with cleaning compound, wear approved chemical cartridge respirator, rubber gloves, safety goggles, and protective clothing. Keep away from heat and open flames. Use in a well-ventilated area.



COMPRESSED AIR

When using compressed air for any cleaning or drying operation, do not exceed 30 psig at the nozzle. Eyes can be permanently damaged by contact with liquid or large particles propelled by compressed air. Inhalation of air-blown particles or solvent vapor can damage lungs. If injury occurs, get immediate medical attention. When using air for drying or cleaning at an air-exhausted workbench, wear approved goggles or faceshield. When using air for drying or cleaning at an unexhausted workbench, wear approved respirator and goggles.



CORROSION PREVENTIVE COMPOUND, MIL-C-11796

If solution of petrolatum corrosion preventive compound is decomposed by heat, toxic gases are released. Prolonged contact with solution or mist can cause skin irritation. If there is any prolonged contact with skin, wash contacted area with soap and water. If solution contacts eyes, flush eyes with water immediately. Remove saturated clothing. If solution is swallowed, do not try to vomit. In all cases get immediate medical attention. When handling solution, wear approved rubber gloves. If prolonged contact with mist is likely, wear approved respirator.



CORROSION PREVENTIVE COMPOUND, MIL-C-16173

Corrosion preventive compound is combustible; do not use near open flames, near welding areas, or on hot surfaces. Prolonged contact with skin

can cause skin irritation. Prolonged inhalation of vapor can cause dizziness, headache, and intoxication. If there is any prolonged contact with skin, wash affected area with soap and water. If liquid contacts eyes, flush eyes thoroughly with water. Remove contaminated clothing. If vapors cause light-headedness, go to fresh air. If liquid is swallowed, do not try to vomit. In all cases get immediate medical attention. When handling liquid or when applying it at air-exhausted workbench, wear approved gloves. When handling liquid or when applying it at unexhausted workbench, wear approved gloves and goggles. Dispose of liquid-soaked rags in approved metal container.

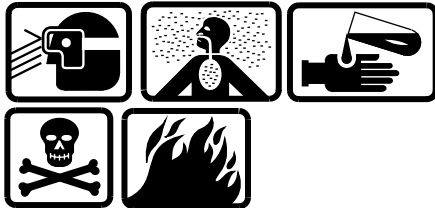

CORROSION PREVENTIVE COMPOUND, MIL-C-27725

Corrosion preventive compound is flammable. Keep away from ignition sources. Overexposure may cause headache, dizziness, nausea, skin drying, eye irritation, and respiratory irritation. Corrosion preventive compound may also cause narcotic effects, shortness of breath and could affect the central nervous system. Thoroughly wash with soap and water and apply emollient cream or lotion and immediately flush eyes with water for 15 minutes. If inhaled move to fresh air. In all cases get immediate medical attention. When working with corrosion preventive compound, wear approved protective gloves, goggles, and clothing. Use in a well-ventilated area. If adequate ventilation is not available, wear approved respirator.



CORROSION REMOVING AND METAL CONDITIONING COMPOUND

Corrosion removing and steel protecting compound causes skin irritation. Avoid contact with skin and eyes. If irritation occurs, get immediate medical attention. Wear approved gloves and goggles or faceshield when handling. Wash hands thoroughly after handling.



DENATURED ETHYL ALCOHOL

Denatured ethyl alcohol and its vapor are flammable and explosive — do not use it where others are smoking. POISON — do not ingest. Ingestion will cause vomiting, stupor, and collapse. Inhalation of vapor may cause headache and drowsiness. If vapors cause drowsiness, go to fresh air. Immediately remove wet clothing. When working with denatured ethyl alcohol, wear approved respirator, gloves, and goggles. If splashing could occur, wear an approved faceshield over the goggles. In case of contact with eyes, flush with water for at least 20 minutes and obtain medical attention. Dispose of liquid soaked rags in approved metal container. Metal containers must be grounded to maintain electrical continuity.



DRILLING OPERATIONS

Metallic structures drilling operations produce airborne metallic dust particles that are harmful to respiratory tract and eyes. Avoid breathing dust and use eye protection when drilling. Avoid composite materials that are toxic to skin, eyes and respiratory tract. When drilling advanced composite materials, avoid inhalation of dust and wear protective gloves and eye protection.



DRY LUBRICANT

Overexposure can cause nausea, vomiting, and irritation of skin, eyes, and respiratory system. If symptoms occur, seek fresh air. Wash affected skin with soap and water. Flush eyes with water for 15 minutes. If ingested do not induce vomiting. In all cases, seek medical attention. Wear approved protective gloves, goggles, and respirator.

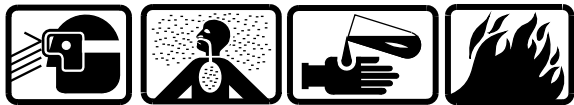

DRYCLEANING SOLVENT

Drycleaning solvent is combustible; do not use near open flames, near welding areas, or on hot surfaces. Prolonged contact of skin with liquid can cause skin irritation. Repeated inhalation of vapor can irritate nose and throat and can cause dizziness. If any liquid contacts skin or eyes, immediately flush affected area thoroughly with water. Remove solvent-saturated clothing. If vapors cause dizziness, go to fresh air. In all cases get immediate medical attention. When handling liquid or when applying it in an air-exhausted, partially covered tank, wear approved gloves. When handling liquid or when applying it at an unexhausted, uncovered tank or workbench, wear approved respirator and goggles.



DYNASOLVE 165

Dynasolve 165 contains powerful organic solvents. It is harmful if inhaled or swallowed. Avoid breathing vapors or mist. Keep away from heat and flame. Avoid contact with eyes and skin. Wear gloves, safety goggles, and protective clothing when handling. Use with adequate ventilation. Contact of skin with liquid or inhalation of vapor can cause severe burns, and respiratory system irritation. If any solution, liquid, or vapor contacts skin or eyes, flush affected areas thoroughly with water. Immediately change any contaminated clothing. If vapors are inhaled, go to fresh air. In all cases get immediate medical attention.



ELECTRIC SHOCK

To prevent electric shock, ensure electrical power is off before working on helicopter. Remove watches, rings and other jewelry before working on electrical circuits. Voltage and/or current may be contacted that could present a threat to your health or life. If voltage/current is contacted and

breathing ceases, CPR must be administered by qualified personnel. Seek medical aid. For electrical shock safety steps and procedures, refer to TM 1-1500-204-23 and TB 385-4.



EPOXY PRIMER COATING

Epoxy primer coating is flammable. It contains lead and may cause irritation of nose, throat, eyes, skin, respiratory system, and nervous system. Overexposure may result in headache, narcotic effect, nervousness, drying of skin, and possible death. Thoroughly wash skin area with soap and water and immediately flush eyes with water for 15 minutes. If ingested, do not induce vomiting. In all cases get immediate medical attention. When working with epoxy primer coating wear approved respirator, chemical splash goggles, solvent resistant gloves, apron, protective clothing, and barrier cream. Work in a well-ventilated area.



EPOXY RESIN

Filled epoxy resin may cause skin and eye irritation. Thoroughly wash skin area with soap and warm water and immediately flush eyes with water for 15 minutes. In all cases get immediate medical attention. When working with epoxy resin, wear approved protective gloves and goggles. Use in a well-ventilated area and avoid breathing vapors.



FINGERPRINT REMOVER

Fingerprint remover is flammable. Do not use near heat or flames. Overexposure may cause skin and eye irritation, dizziness, headache and nausea. Thoroughly wash skin area with soap and water and immediately flush eyes with water for 15 minutes. If inhaled, move to fresh air. In all cases get immediate medical attention. When working with fingerprint remover wear approved solvent

resistant gloves, goggles or faceshield, and respirator.



FLUORESCENT PENETRANT

Prolonged or repeated inhalation of powders and vapors of cleaning solvent, developers, and emulsifiers used in fluorescent penetrant inspection can irritate mucous membrane areas of the body. Continual exposure to penetrant inspection materials can irritate the skin. Direct exposure of eyes to light and prolonged exposure of skin to light can inflame and damage eyes and skin. Wear approved neoprene gloves when handling penetrant inspection materials. Keep insides of gloves clean. Store all pressurized spray cans containing penetrants, developers, and emulsifiers in a cool, dry area protected from direct sunlight, heat, and open flames. Temperatures higher than 120 °F (49 °C) may cause pressurized can to burst and cause injury. If direct eye contact with light causes eye problems, get immediate medical attention. When using black light for fluorescent inspections, wear approved safety glasses.



GREASE

Avoid any skin contact with grease. Wash hands thoroughly with soap and water after handling grease.



HYDRAULIC FLUID, MIL-H-5606

MIL-H-5606 hydraulic fluid is flammable. Flashpoint is 180 °F (82 °C). When hydraulic fluid is decomposed by heat, toxic gases are released. Prolonged contact with liquid or mist can cause skin irritation. If there is any prolonged contact with skin, wash contacted area with soap and water. If liquid contacts eyes, flush eyes with water immediately. Remove saturated clothing. If

fluid is swallowed, do not try to vomit. In all cases get immediate medical attention. When handling liquid, wear approved rubber gloves. If prolonged contact with mist is likely, wear approved respirator.



HYDRAULIC FLUID, MIL-H-83282

MIL-H-83282 hydraulic fluid is flammable. Flashpoint is 400 °F (204 °C). When hydraulic fluid is decomposed by heat, toxic gases are released. Prolonged contact with liquid or mist can cause skin irritation. If there is any prolonged contact with skin, wash contacted area with soap and water. If liquid contacts eyes, flush eyes with water immediately. Remove saturated clothing. If fluid is swallowed, do not try to vomit. In all cases get immediate medical attention. When handling liquid, wear approved rubber gloves. If prolonged contact with mist is likely, wear approved respirator.



ISOPROPYL ALCOHOL

Isopropyl alcohol is flammable; do not use near open flames, near welding areas, or on hot surfaces. Do not use while smoking or while others are smoking. Inhalation of vapors can cause drowsiness, dizziness, and headache. Contact with skin may cause irritation. If liquid touches skin or eyes, flush thoroughly with water. Remove contaminated clothing. If vapors cause drowsiness, go to fresh air. When handling large quantities (greater than 1 gallon), work at air-exhausted workbench or covered tank. Store solvent and liquid-soaked clothes in an approved, grounded metal container.



JET FUEL

Jet fuel is flammable; do not use near open flames, welding areas, or on hot surfaces. Do not

handle or store near strong oxidants, e.g., liquid oxygen or hypochlorite. Do not smoke when using jet fuel and do not use it where others are smoking. Contact of eyes with liquid can cause severe irritation and blurred vision. Inhalation of vapor may cause irritation, headache, nausea, and dizziness. If liquid contacts eyes, flush eyes thoroughly with water for a minimum of 15 minutes. Immediately remove fuel-saturated clothing. If vapors cause dizziness, go to fresh air. If liquid is swallowed, do not try to vomit. In all cases get immediate medical attention. When handling large quantities of liquid (more than 1 gallon) at an unexhausted workbench, wear approved respirator and goggles or faceshield. Dispose of liquid-soaked rags in approved metal container. Contaminated clothing shall be laundered prior to reuse. Metal containers of fuel must be closed and grounded to maintain electrical continuity.

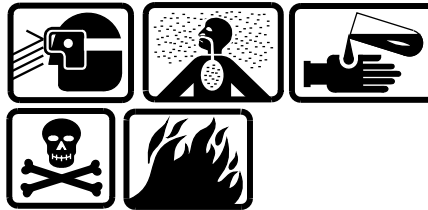

LUBRICANT, SOLID FILM

Solid film lubricant is flammable. Do not use near fire or open flame. Lubricant may cause irritation to skin and upper respiratory system. Inhalation may cause a narcotic effect and light headedness. Swallowing may be fatal. Thoroughly wash skin area with soap and water and immediately flush with water for 15 minutes. If ingested, do not induce vomiting. In all cases get immediate medical attention. When working with lubricant, wear approved rubber gloves, respirator, and safety glasses or goggles with unperforated side shields. Work in a well-ventilated area.

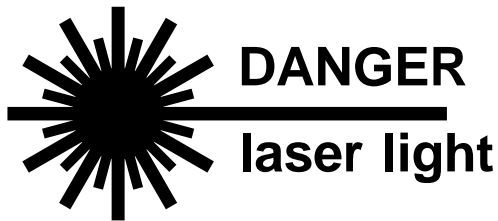

LUBRICATING OIL

The laser rangefinder/designator (LRF/D) is very dangerous. Looking at the laser beam or its reflection from a shiny surface can cause permanent blindness. Under noncombat conditions, the laser shall be used only in controlled areas and at times specified by a range control officer.

If lubricating oil is decomposed by heat, toxic gases are released. Prolonged contact with liquid or mist may cause skin irritation. If there is any prolonged contact with skin, wash area with soap and water. If oil contacts eyes, flush eyes with water immediately. Remove saturated clothing. If oil is swallowed, do not try to vomit. In all cases get immediate medical attention. When handling liquid, wear approved rubber gloves. If prolonged contact with mist is likely, wear approved respirator.



LHE CADMIUM SOLUTION

Cadmium brush plating solution is toxic and may cause damage to skin, eyes, and mucous membranes. Overexposure may cause skin sensitization and skin irritation. Thoroughly wash skin area with water and immediately flush eyes with water for 15 minutes. If vapor causes drowsiness, go to fresh air. In all cases get immediate medical attention. Wear approved rubber gloves, apron, boots, goggles or faceshield, and activated carbon respirator. Work in well-ventilated area. Wash hands thoroughly before eating or smoking.



NAPHTHA/NAPHTHALENE

Naphtha/Naphthalene is combustible; do not use it near welding areas, near flames, or on hot surfaces. Avoid prolonged or repeated contact with liquid. Contact of skin with liquid can cause irritation. Inhalation of vapors can cause irritation, giddiness, and drowsiness. If liquid contacts eyes, flush eyes thoroughly with water. If there is any prolonged skin contact, wash contacted area with

soap and water. If vapors cause drowsiness, go to fresh air. Remove solvent-saturated clothing. If liquid is swallowed, do not try to vomit. In all cases get immediate medical attention. When handling liquid in an air-exhausted, partially covered tank, wear approved gloves. When handling liquid in an open, unexhausted container, wear approved rubber gloves and goggles. If contact with vapor is likely, wear an approved respirator. Dispose of liquid-soaked rags in approved metal container. Metal containers of liquid must be grounded to maintain electrical continuity.

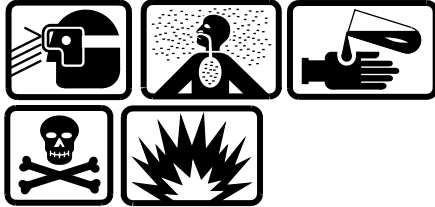

NITRIC ACID

Nitric acid is highly reactive; do not mix with combustible organics or other oxidizable materials such as wood, paper, and cloth. When heated, toxic gases are released. When mixing solutions, add acid slowly to water, not water to acid. Contact of skin with liquid or inhalation of mist can cause severe burns, respiratory system irritation, and chronic bronchitis. If any solution, liquid, or mist contacts skin or eyes, flush affected area thoroughly with water for a minimum of 15 minutes. Immediately change any contaminated clothing. If mist is inhaled, go to fresh air. In all cases get immediate medical attention. If handling solution or concentrated liquid in air-exhausted covered tank, wear approved gloves and apron, and wear approved goggles or faceshield. When handling solution or concentrated liquid in open tank, wear approved respirator, full-body clothing, gloves, and goggles.



NOISE HAZARD

Personnel hearing can be PERMANENTLY DAMAGED if exposed to constant high noise levels of 85 dB (A) or greater. Wear approved hearing protection devices when working in high noise level areas. Hearing loss occurs gradually

but becomes permanent over time. Hearing protection is required.



PAINT REMOVER

Paint remover can cause severe burns, narcotic effects, headache, dizziness, and nausea. In some cases it may cause elevated blood pressure, unconsciousness, shock, and death. Contact with eyes may cause blindness. Avoid contact with flammable liquids. Contact with alkali metals, powdered magnesium, and aluminum may cause a violent reaction. Thoroughly wash skin area with water and immediately flush eyes with water for 15 minutes. In all cases get immediate medical attention. When working with paint remover wear approved respirator (manufacturer recommends approved fresh air mask), approved faceshield or goggles, neoprene or Viton gloves, solvent resistant boots, and apron. Work in a well-ventilated area. Read manufacturers label for specific instruction due to variations of each product.



PLASTIC POLISH COMPOUND

Plastic polish compound is flammable. Keep away from heat, open flame or other sources of ignition. Plastic polish compound may be poisonous if inhaled or absorbed through the skin. Vapors may cause dizziness or suffocation and are an irritant to the skin and eyes. Move to fresh air and thoroughly wash skin with water and flush eyes with water for 15 minutes. In all cases, get immediate medical attention. Wear approved safety glasses or goggles and gloves. Use in a well-ventilated area.



POLYURETHANE COATING

Polyurethane coating is flammable. Keep away from open flame, sparks, heat, and organic material. Exposure can cause skin, eye, nose, throat, and respiratory system irritation. Prolonged exposure may cause headache, allergic sensitivity, narcotic effect, nausea, and vomiting. Ingestion causes lead poisoning. Thoroughly wash skin area with soap and water and immediately flush eyes with water for 15 minutes. If inhaled, move to fresh air. In all cases get immediate medical attention. When working with polyurethane coating, wear approved chemical resistant rubber gloves, goggles, respirator, and protective clothing. Use in a well-ventilated area.



POLYURETHANE CONDUCTIVE COATING

Polyurethane conductive coating is flammable; do not use near open flames, near welding areas, or on hot surfaces. Contact with liquid or vapor can cause skin or eye irritation. Prolonged overexposure can result in kidney and liver damage, headache, nausea, vomiting, dizziness or loss of consciousness. Prolonged occupational overexposure can result also with permanent brain and nervous system damage. Deliberately concentrating and inhaling the contents may be harmful or fatal. After prolonged skin contact, wash contacted area with lukewarm water for 15 minutes. Remove contaminated clothing promptly. If vapors cause dizziness, go to fresh air, in all cases get immediate medical attention. Dispose of contents in approved metal container. Follow approved toxic waste disposal procedures.



RESINS AND HARDENERS

Resins and hardeners are flammable; do not use near open flames, welding areas, or on hot surfaces. When decomposed by heating, toxic fumes are released. Inhalation of vapor can cause irritation, drowsiness, and headache. Contact with eyes can cause severe burns. Flush eyes with water for at least 15 minutes. Wash skin immediately with soap and water. In all cases get immediate medical attention. When mixing or applying liquid in air-exhausted paint spray booth, wear approved gloves and goggles. When mixing or applying liquid in unexhausted work area, wear approved gloves, long sleeves, apron, goggles, and respirator. Metal containers of solution must be grounded to maintain electrical continuity.

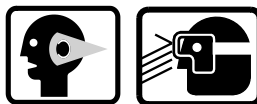

RIVETING OPERATIONS

Bucking rivets produces high levels of noise. Hearing can be PERMANENTLY DAMAGED if exposed to constant high noise levels of 85 dB (A) or greater. Wear approved hearing protection devices when working in high noise level areas. Hearing loss occurs gradually but becomes permanent over time. Hearing protection is required. Wear goggles or faceshield when riveting to prevent damaging eyes.



SANDING OPERATIONS

Avoid prolonged or repeated contact with sanding, power grinding, or drilling dust. Inhalation of dust may cause temporary coughing and wheezing, respiratory system irritation, and permanent lung problems. If dust contacts eyes, flush them thoroughly with water. If coughing or wheezing persists, get immediate medical attention. When using an air-exhausted grinding wheel, wear approved respirator and goggles or faceshield.



SEALING COMPOUND, MIL-S-22473

Anaerobic sealing compound is flammable; do not use near open flames or welding areas. Avoid prolonged exposure to light. Avoid materials such as peroxide or other strong oxidizing agents, iron rust or carbon monoxide/dioxide. Anaerobic sealing compound can cause dermatitis. It may also cause delayed eye and skin irritations and skin sensitivity. Thoroughly wash skin area with water and immediately flush eyes with water for at least 15 minutes. If ingested, do not induce vomiting. Keep individual calm. In all cases, get immediate medical attention. When working with anaerobic sealing compound, wear approved rubber apron, boots, gloves, and goggles or faceshield in well-ventilated area.

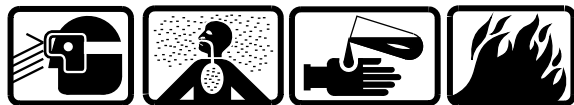

SEALING COMPOUND, MIL-S-8784, MIL-S-8802, MIL-S-83249

Sealing compound is flammable. Do not use near heat, open flames, or sparks. Overexposure can cause irritation of skin and eyes, headache, nausea, vomiting, and systemic problems. Thoroughly wash skin area with soap and water and immediately flush eyes with water for 15 minutes. In all cases get immediate medical attention. Wear approved protective gloves and goggles. Avoid breathing of vapors and prolonged or repeated skin contact.

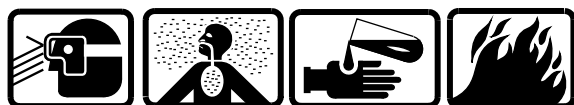

SHELLAC

Shellac is flammable. Keep away from heat, sparks, and open flame. All electrical equipment must be explosion proof. Shellac may cause irritation of eyes, nose, and throat. Headache, intoxication, and drowsiness may occur. In case of skin contact, flush contact area thoroughly with water. For inhalation, remove to fresh air and give oxygen. In all cases, get immediate medical attention. Use shellac in well-ventilated area. When handling wear approved rubber gloves and safety goggles.



SILICONE

Conformal coating is flammable. Do not use near open flame or high temperatures. Repeated or prolonged contact or inhalation of vapors can cause skin and eye irritation, or damage to lungs, blood, liver, kidneys, and nervous system. Existing eye, skin, and respiratory disorders can be aggravated. Short-term inhalation of vapors can cause drowsiness and irritation of nose and throat. Use only in a well-ventilated area. If vapors are inhaled, go to fresh air. Short-term skin contact can cause irritation, redness, and swelling. Wipe off skin contact area and flush with fresh water. Flush eyes with with fresh water for 15 minutes. Get immediate medical attention if irritation develops or ill effects persist. If swallowed, do not induce vomiting. Vomiting can cause serious lung damage. If vomiting occurs, keep head below hips to prevent entry of liquid into lungs. When handling, wear approved protective gloves, goggles, and respirator with organic vapor cartridge. Metal storage containers must be grounded to eliminate static electricity fire hazard.

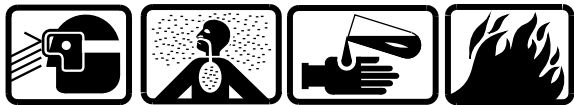

THINNER

Paint thinner is flammable; do not use near open flames, near welding areas, or on hot surfaces. Do not smoke when using paint thinner, and do not use it where others are smoking. Contact with liquid or vapor can cause skin, nose, throat, and eye irritation, drowsiness, headache, nausea, and vomiting. After any prolonged contact of liquid with skin, wash contacted area with soap and water. Remove solvent-saturated clothing. If vapors cause drowsiness, go to fresh air. In all cases get immediate medical attention. When handling liquid at air-exhausted workbench wear approved gloves, goggles, and long sleeves. When handling liquid or liquid-soaked cloth in open unexhausted area, wear approved respirator, gloves, and goggles. Dispose of liquid-soaked rags in approved metal container. Metal containers must be grounded to maintain electrical continuity.



URETHANE ADHESIVE

Urethane Adhesive Components A and B are flammable. Keep away from heat, sparks, or any source of ignition.

Overexposure to Component A may cause headache, nausea, and skin irritation and is an irritant to the upper respiratory system. In case of skin or eye contact, flush thoroughly with water. If inhaled remove to fresh air. If swallowed give large amounts of water. In all cases get immediate medical attention.

Overexposure to Component B, which is mildly toxic, may cause headache and mild irritation of nose, throat, and eyes. Contact with skin may cause irritation and dryness. Ingestion may cause vomiting and stomach cramps. In case of ingestion, get immediate medical attention. If inhaled remove to fresh air and give artificial respiration. In case of skin contact, remove contaminated clothing and wash with soap and water. Flush eyes immediately with large quantities of water. In all cases get immediate

medical attention. Use in well-ventilated area and wear approved respirator, goggles, and rubber gloves.



ZINC CHROMATE PRIMER

Zinc chromate primer is flammable; do not use near open flames, near welding areas, or on hot surfaces. Do not smoke when using zinc chromate primer, and do not use it where others are smoking. Contact with liquid or vapor can cause skin or eye irritation, dizziness, and headache. Prolonged inhalation can result in kidney and liver damage. After prolonged skin contact, wash contacted area with soap and water. If vapors cause dizziness, go to fresh air. In all cases get immediate medical attention. When handling small quantities (less than 1 gallon), wear approved gloves. When handling large quantities of liquid (greater than 1 gallon), at unexhausted workbench, wear approved respirator, gloves, goggles, apron, and long sleeves. Do not eat, smoke, or carry smoking materials in areas where liquid is handled. Dispose of liquid-soaked rags in approved metal container. Zinc chromate primer contains chromates. Follow approved toxic waste disposal procedures.



ZINC CHROMATE PUTTY

Zinc chromate putty is flammable; do not use near open flames, near welding areas, or on hot surfaces. Do not smoke when using zinc chromate putty, and do not use it where others are smoking. Contact with liquid or vapor can cause skin or eye irritation, dizziness, and headache. Prolonged inhalation can result in kidney and liver damage. After prolonged skin contact, wash contacted area with soap and water. If vapors cause dizziness, go to fresh air. In all cases get immediate medical attention. When handling small quantities (less than 1 gallon), wear approved gloves. Do not eat, smoke, or carry smoking materials in areas where putty is handled. Dispose of putty in approved

metal container. Zinc chromate putty contains chromates. Follow approved toxic waste disposal procedures.

4. SAFETY PRECAUTIONS.

The following safety precautions shall be observed while performing procedures in this manual.

- Dangerous voltages are present at system connectors. Ensure power is OFF prior to connecting or disconnecting cables.
- Do not wear metal frame glasses, rings, watches, or other metal jewelry while working on electronic equipment.
- Some cleaning materials specified herein are flammable and/or toxic. Keep away from open flame or other ignition sources. Provide adequate ventilation and avoid skin/eye exposure.
- Cleaning with compressed air can create airborne particles that may enter eyes or penetrate skin. Pressure shall not exceed 30 psig. Wear goggles. Do not direct compressed air against skin.
- For electrical shock safety steps and procedures, refer to TM 1-1500-204-23 and TB 385-4.

Wiring Diagrams

This volume contains wiring diagrams for all electrical systems and circuits. Essential wiring information will be found in Appendix F. The following systems foldout wiring diagrams are located in this volume.

TITLE	FIGURE NUMBER	PAGE NUMBER
DC Power System Wiring Diagram (OH-58D)	FO-1	FP-1
AC Power System Wiring Diagram (OH-58D)	FO-2	FP-17
Lighting System Wiring Diagram (OH-58D)	FO-3	FP-21
Powerplant and Transmission System Wiring Diagram (OH-58D)	FO-4	FP-31
SCAS, Hydraulic, and Standby Attitude Gyro System Wiring Diagram (OH-58D)	FO-5	FP-47
Environmental Electrical System Wiring Diagram (OH-58D)	FO-6	FP-61
Mast Mounted Sight (MMS) System Wiring Diagram (OH-58D)	FO-7	FP-63
Control Display System (CDS) Wiring Diagram (OH-58D)	FO-8	FP-71
Transmission Attitude Measurement System (TAMS) Wiring Diagram (OH-58D)	FO-9	FP-91
Air-to-Air Stinger (ATAS) Missile System Wiring Diagram (OH-58D)	FO-10	FP-93
Guns and Rockets System Wiring Diagram (OH-58D)	FO-11	FP-99
HELLFIRE Missile System (HMS) Wiring Diagram (OH-58D)	FO-12	FP-107
Cargo Hook System Diagram (OH-58D)	FO-13	FP-113
Engine Barrier Filter (EBF) System Wiring Diagram (OH-58D)	FO-13.1	FP-114.1
Cockpit Airbag System (CABS) Wiring Diagram (OH-58D)	FO-13.2	FP-114.3
DC Power System Wiring Diagram (OH-58D (R))	FO-14	FP-115
AC Power System Wiring Diagram (OH-58D (R))	FO-15	FP-127
Lighting System Wiring Diagram (OH-58D (R))	FO-16	FP-131
Power Plant and Transmission System Wiring Diagram (OH-58D (R))	FO-17	FP-139
SCAS, Hydraulic, and Standby Attitude Gyro System Wiring Diagram (OH-58D (R))	FO-18	FP-157
Environmental Electrical System Wiring Diagram (OH-58D (R))	FO-19	FP-169

TM 1-1520-248-23-7

Mast Mounted Sight (MMS) System Wiring Diagram (OH-58D (R))	FO-20	FP-171
Control Display System (CDS) Wiring Diagram (OH-58D (R))	FO-21	FP-181
Transmission Attitude Measurement System (TAMS) Wiring Diagram (OH-58D (R))	FO-22	FP-201
Air-to-Air Stinger (ATAS) Missile System Wiring Diagram (OH-58D (R))	FO-23	FP-203
Guns and Rockets System Wiring Diagram (OH-58D (R))	FO-24	FP-215
HELLFIRE Missile System (HMS) Wiring Diagram (OH-58D (R))	FO-25	FP-223
Cargo Hook System Wiring Diagram (OH-58D (R))	FO-26	FP-229
Engine Barrier Filter (EBF) System Wiring Diagram (OH-58D (R))	FO-26.1	FP-230.1
Cockpit Airbag System (CABS) Wiring Diagram (OH-58D (R))	FO-26.2	FP-230.3

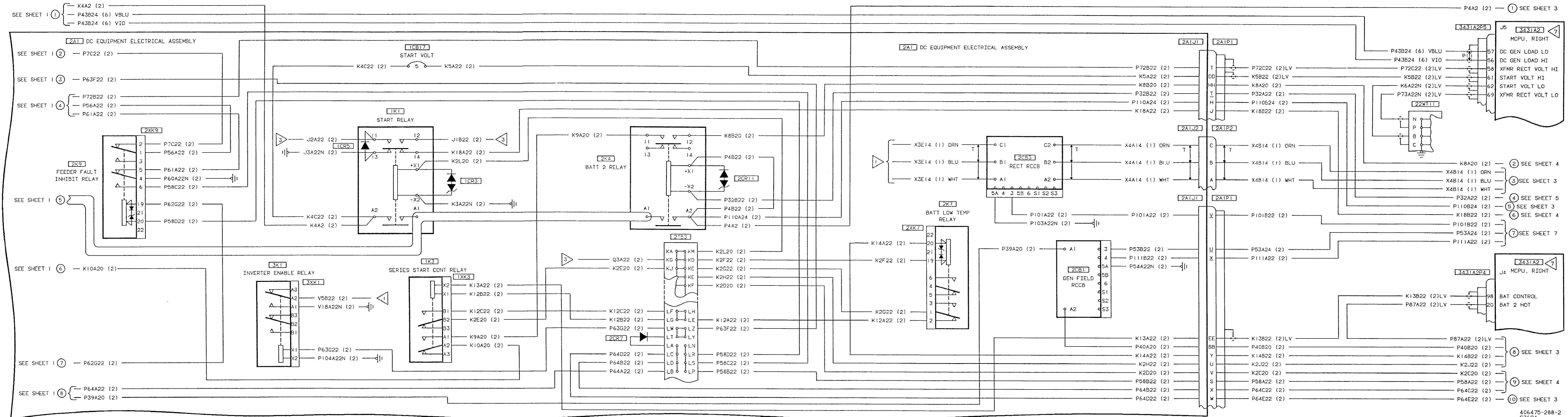

Figure FO-1. DC Power System Wiring Diagram (OH-58D) (Sheet 2 of 8)

406475-288-2
G3694

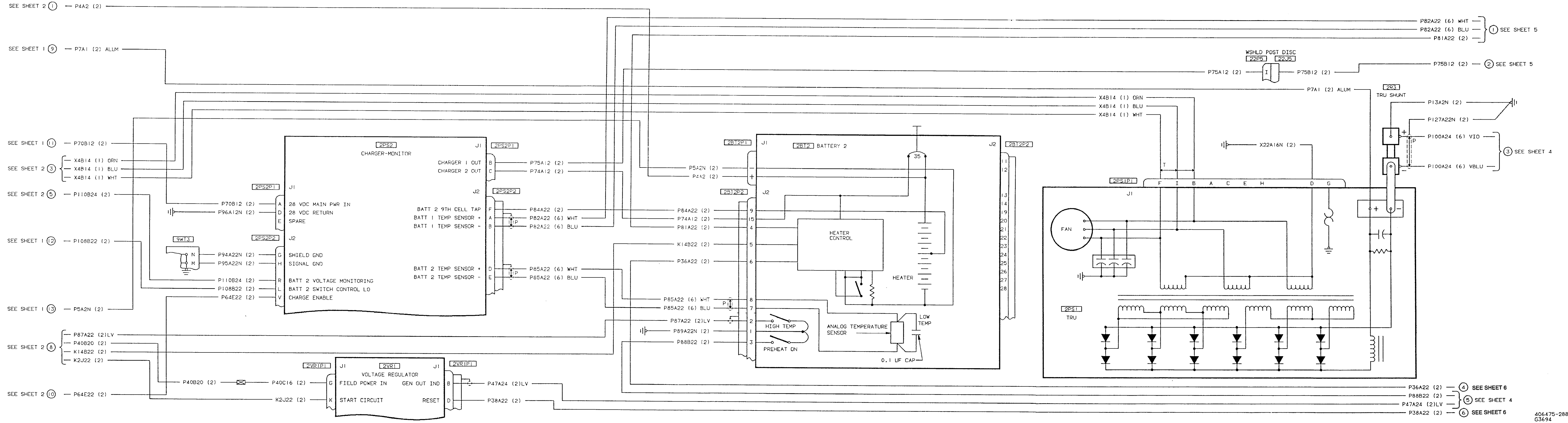

Figure FO-1. DC Power System Wiring Diagram (OH-58D) (Sheet 3 of 8)

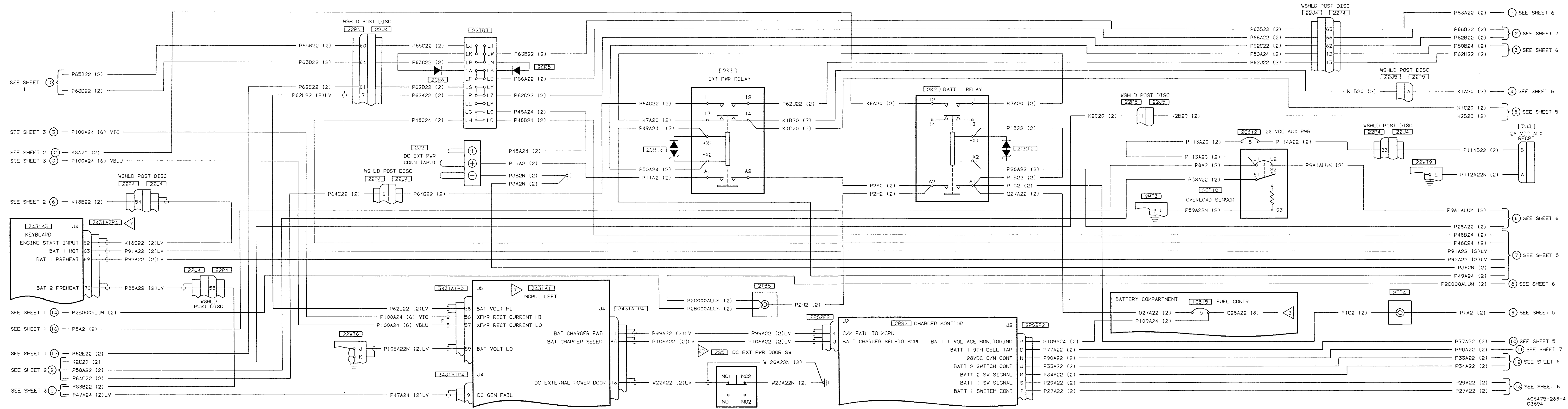

Figure FO-1. DC Power System Wiring Diagram (OH-58D) (Sheet 4 of 8)

406475-288-4
G3694

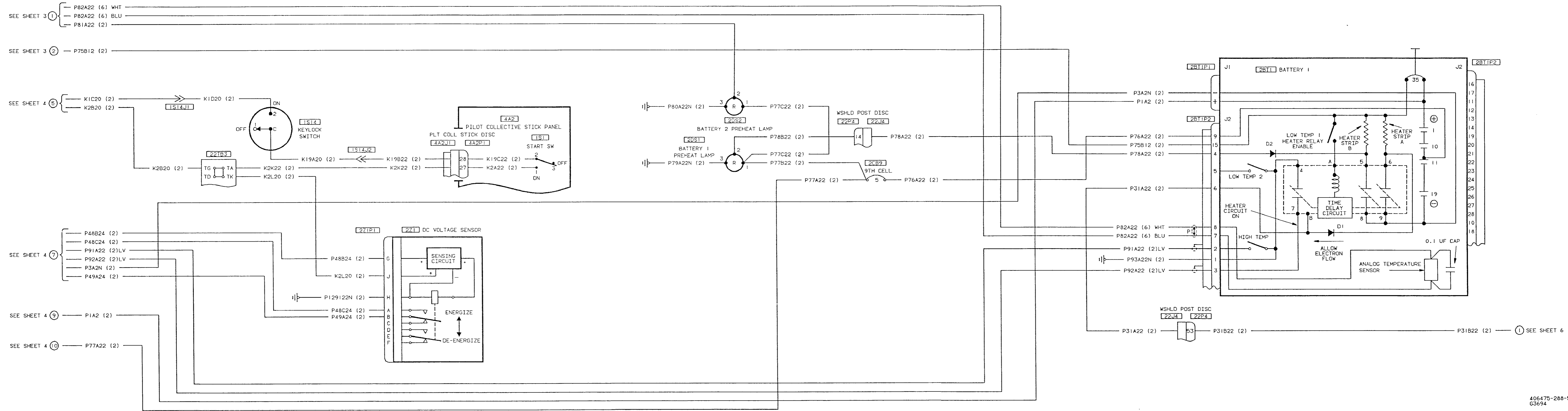

Figure FO-1. DC Power System Wiring Diagram (OH-58D) (Sheet 5 of 8)

406475-288-5
G3694

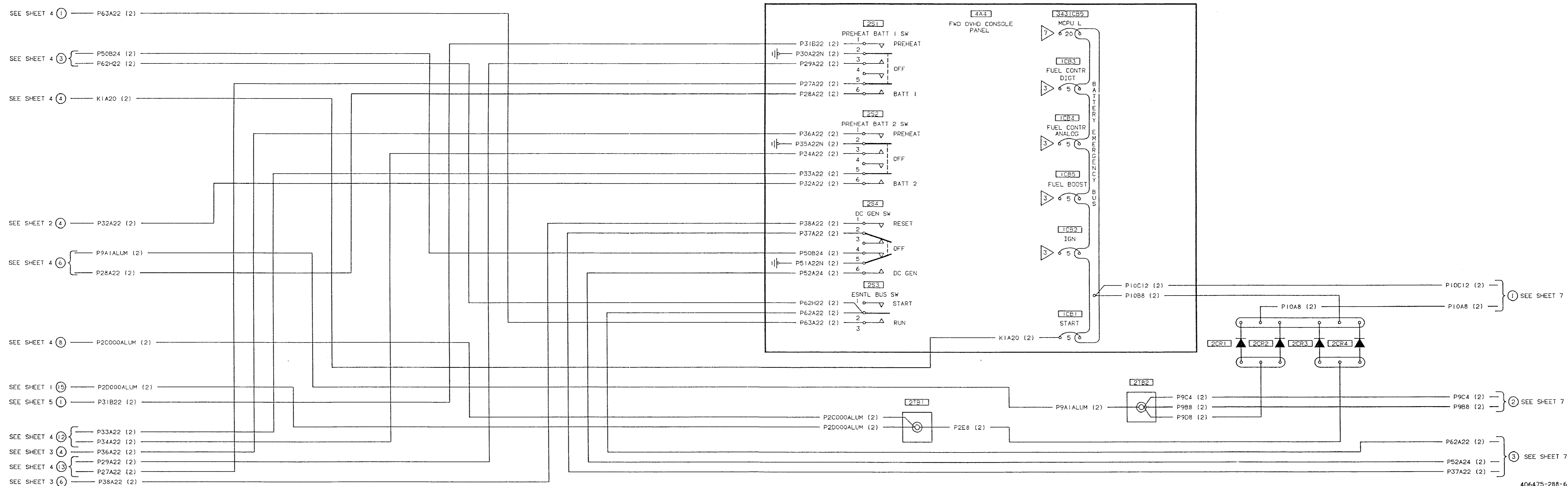

Figure FO-1. DC Power System Wiring Diagram (OH-58D) (Sheet 6 of 8)

406475-288-6
G3694

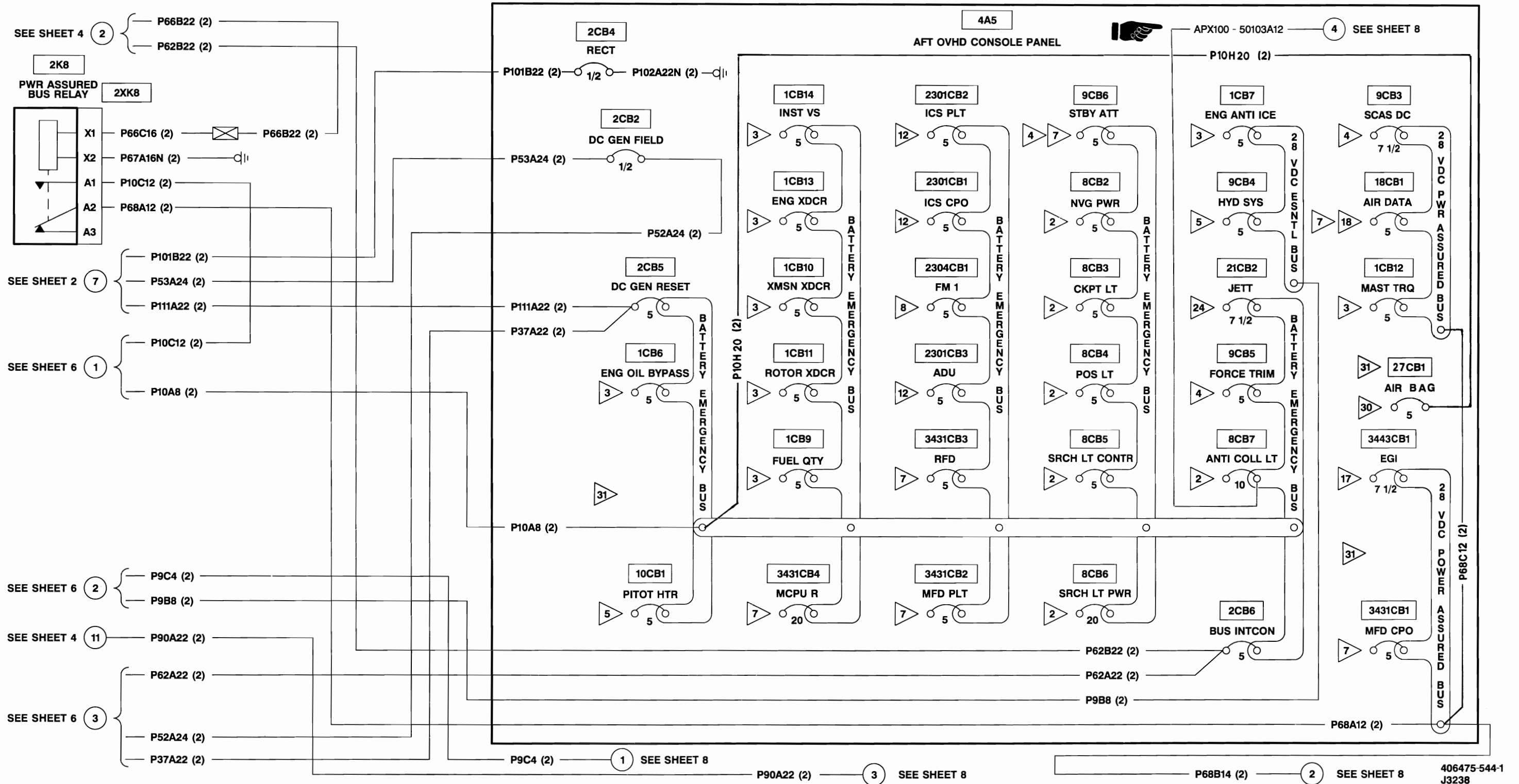
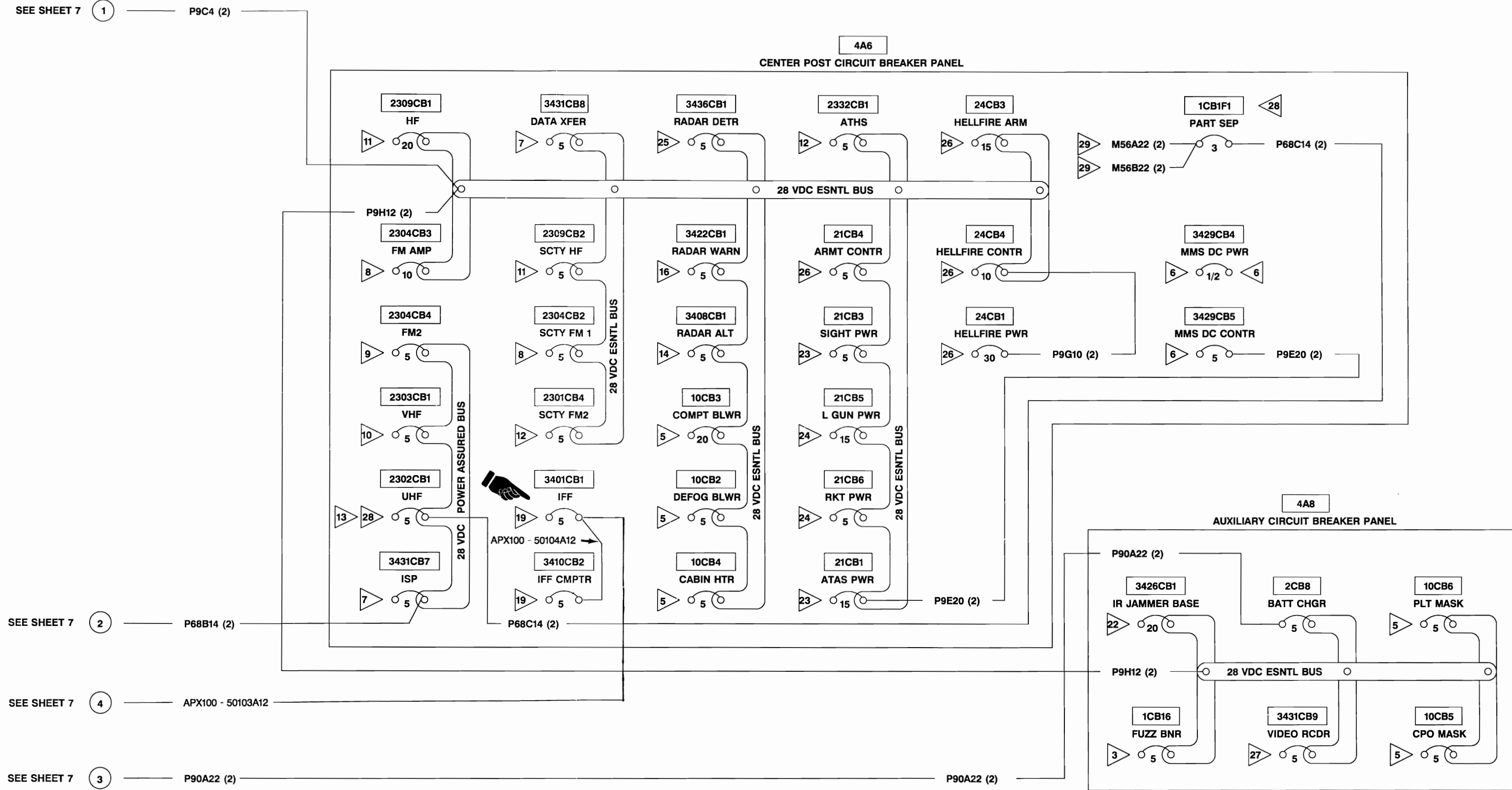

Figure FO-1. DC Power System Wiring Diagram (OH-58D) (Sheet 7 of 8)



SEE SHEET 7 (1) — P9C4 (2)

SEE SHEET 7 (2) — P68B14 (2)

SEE SHEET 7 (4) — APX100 - 50103A12

SEE SHEET 7 (3) — P90A22 (2)

NOTES

- 1 REFER TO AC POWER SYSTEM WIRING DIAGRAM.
- 2 REFER TO LIGHTING SYSTEM WIRING DIAGRAM.
- 3 REFER TO POWER PLANT AND TRANSMISSION SYSTEM WIRING DIAGRAM.
- 4 REFER TO SCAS, HYDRAULIC, AND STANDBY ATTITUDE GYRO SYSTEM WIRING DIAGRAM.
- 5 REFER TO ENVIRONMENTAL SYSTEM WIRING DIAGRAM.
- 6 REFER TO MAST MOUNTED SIGHT (MMS) SYSTEM WIRING DIAGRAM.
- 7 REFER TO CONTROL DISPLAY SYSTEM (CDS) WIRING DIAGRAM.
- 8 REFER TO NO. 1 VHF-FM WIRING DIAGRAM TM 11-1520-248-23.
- 9 REFER TO NO. 2 VHF-FM WIRING DIAGRAM TM 11-1520-248-23.
- 10 REFER TO VHF-AM WIRING DIAGRAM TM 11-1520-248-23.
- 11 REFER TO HF WIRING DIAGRAM TM 11-1520-248-23.
- 12 REFER TO ICS WIRING DIAGRAM TM 11-1520-248-23.
- 13 REFER TO UHF WIRING DIAGRAM TM 11-1520-248-23.
- 14 REFER TO RADAR ALTIMETER WIRING DIAGRAM TM 11-1520-248-23.
- 15 DELETED.
- 16 REFER TO RADAR WARNING WIRING DIAGRAM TM 11-1520-248-23.
- 17 REFER TO EGI WIRING DIAGRAM TM 11-1520-248-23.
- 18 REFER TO AIR DATA SYSTEM (ADS) WIRING DIAGRAM.
- 19 REFER TO IFF WIRING DIAGRAM TM 11-1520-248-23.
- 20 SEE VIEW A FOR IDENTIFICATION OF SWITCH TERMINALS.
- 21 SIGNIFIES "SEE SHEET _____ " AND FIND SAME CIRCLED NUMBER ON DESIGNATED SHEET WITH MATCHING WIRE NUMBER(S).
- 22 REFER TO AN/ALQ-144 WIRING DIAGRAM TM 11-1520-248-23.
- 23 REFER TO AIR-TO-AIR STINGER (ATAS) SYSTEM WIRING DIAGRAM.
- 24 REFER TO GUNS AND ROCKETS SYSTEM WIRING DIAGRAM.
- 25 REFER TO AN/APR-44 RADAR DETECTOR WIRING DIAGRAM.
- 26 REFER TO HELLFIRE MISSILE SYSTEM (HMS) WIRING DIAGRAM.
- 27 REFER TO VIDEO TAPE RECORDER WIRING DIAGRAM TM 11-1520-248-23.
- 28 AFTER COMPLIANCE WITH ENGINE BARRIER FILTER MWO 1-1520-248-50-15.
- 29 REFER TO ENGINE BARRIER FILTER (EBF) SYSTEM WIRING DIAGRAM.
- 30 REFER TO COCKPIT AIRBAG SYSTEM (CABS) WIRING DIAGRAM.
- 31 AFTER COMPLIANCE WITH COCKPIT AIRBAG SYSTEM MWO 1-1520-248-50-14.

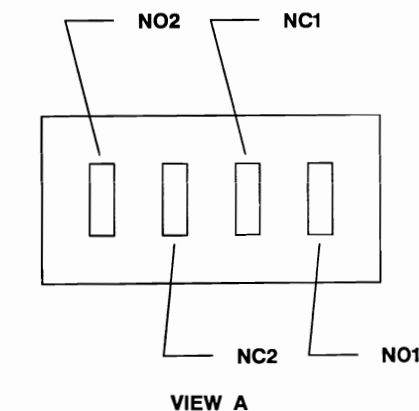

VIEW LOOKING AT REAR OF SWITCH 2S5 WITH KEYWAY UP

406475-544-2
J3238

Figure FO-1. DC Power System Wiring Diagram (OH-58D) (Sheet 8 of 8)

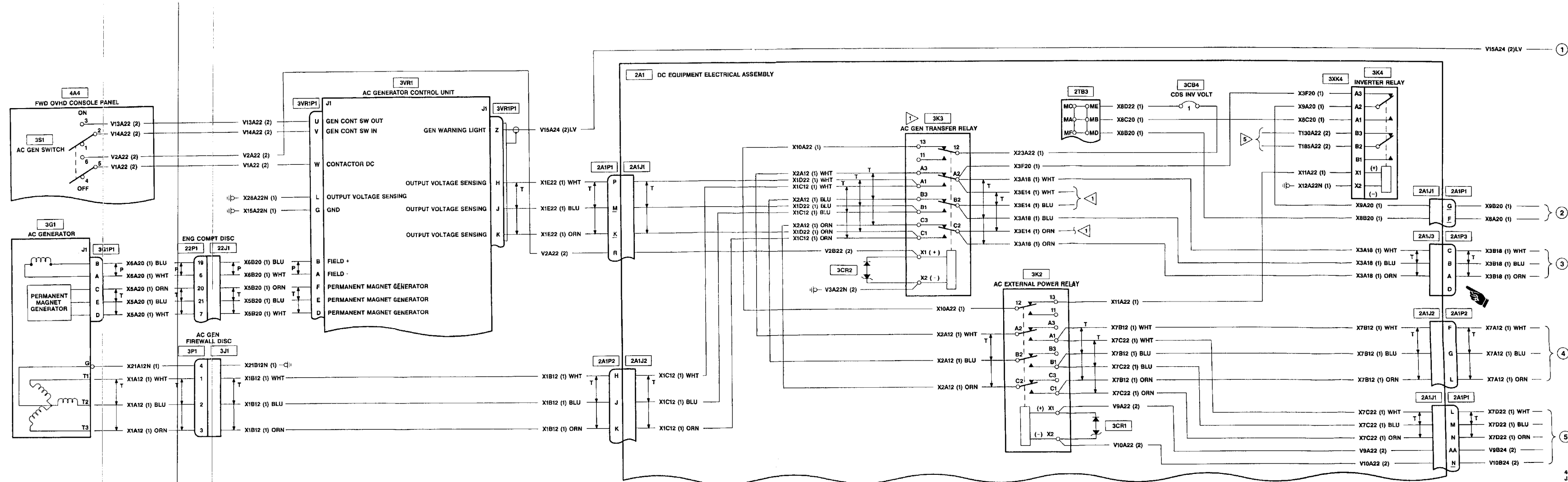
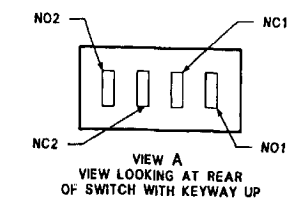
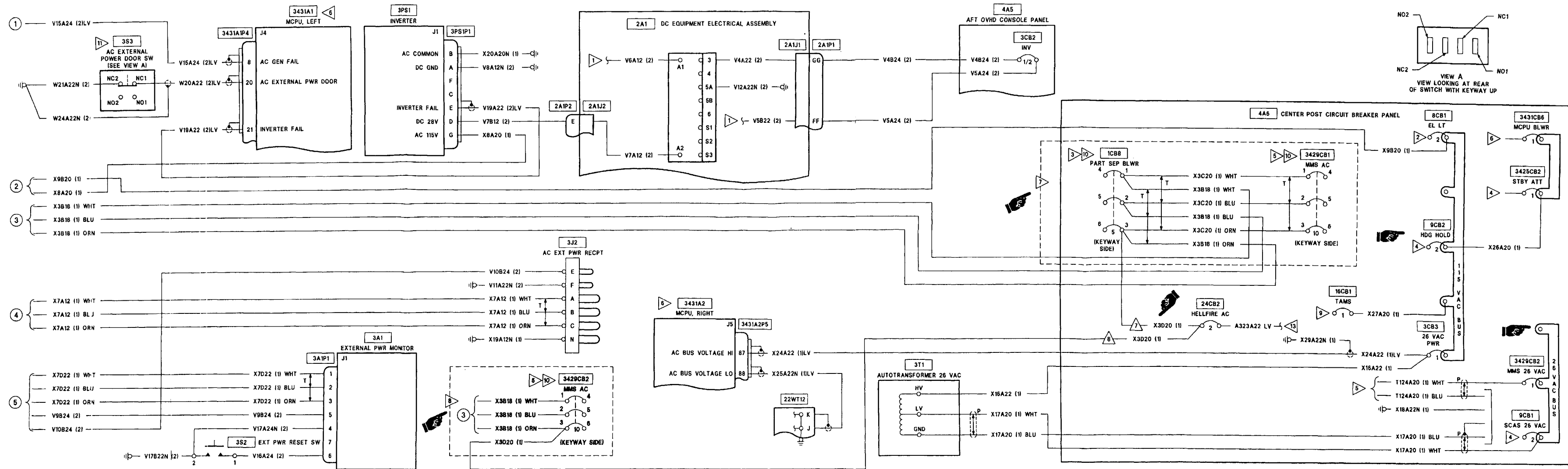

Figure FO-2. AC Power System Wiring Diagram (OH-58D) (Sheet 1 of 2)



- NOTES
- 1 REFER TO DC POWER SYSTEM WIRING DIAGRAM.
 - 2 REFER TO LIGHTING SYSTEM WIRING DIAGRAM.
 - 3 REFER TO POWER PLANT AND TRANSMISSION SYSTEM WIRING DIAGRAM.
 - 4 REFER TO SCAS, HYDRAULIC, AND STANDBY ATTITUDE GYRO SYSTEM WIRING DIAGRAM.
 - 5 REFER TO MMS SYSTEM WIRING DIAGRAM.
 - 6 REFER TO CDS SYSTEM WIRING DIAGRAM.
 - 7 BEFORE COMPLIANCE WITH ENGINE BARRIER FILTER MWO 1-1520-248-50-15.
 - 8 AFTER COMPLIANCE WITH ENGINE BARRIER FILTER MWO 1-1520-248-50-15.
 - 9 REFER TO TAMS SYSTEM WIRING DIAGRAM.
 - 10 VIEW LOOKING AT REAR OF CIRCUIT BREAKER WITH KEYWAY UP; NUMBER WILL READ FROM LEFT TO RIGHT WITH 1, 2, AND 3 ON THE TOP OR KEYWAY SIDE.
 - 11 SWITCH SHOWN WITH DOOR OPEN. SEE VIEW A FOR IDENTIFICATION OF SWITCH TERMINALS.
 - 12 CIRCLED NUMBER SIGNIFIES "GO TO NEXT SHEET" AND FIND SAME CIRCLED NUMBER ON DESTINATION SHEET WITH MATCHING WIRE NUMBER(S).
 - 13 REFER TO HELLFIRE SYSTEM WIRING DIAGRAM.
 - 14 DELETED

Figure FO-2. AC Power System Wiring Diagram (OH-58D) Sheet 2 of 2

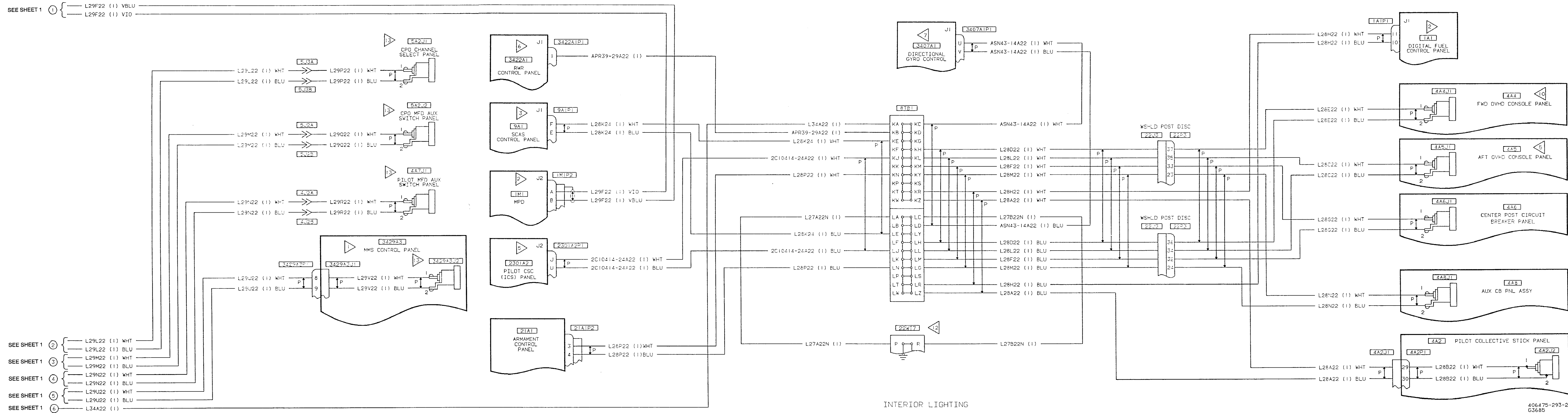

Figure FO-3. Lighting System Wiring Diagram (OH-58D) (Sheet 2 of 5)

406475-293-2
G3685

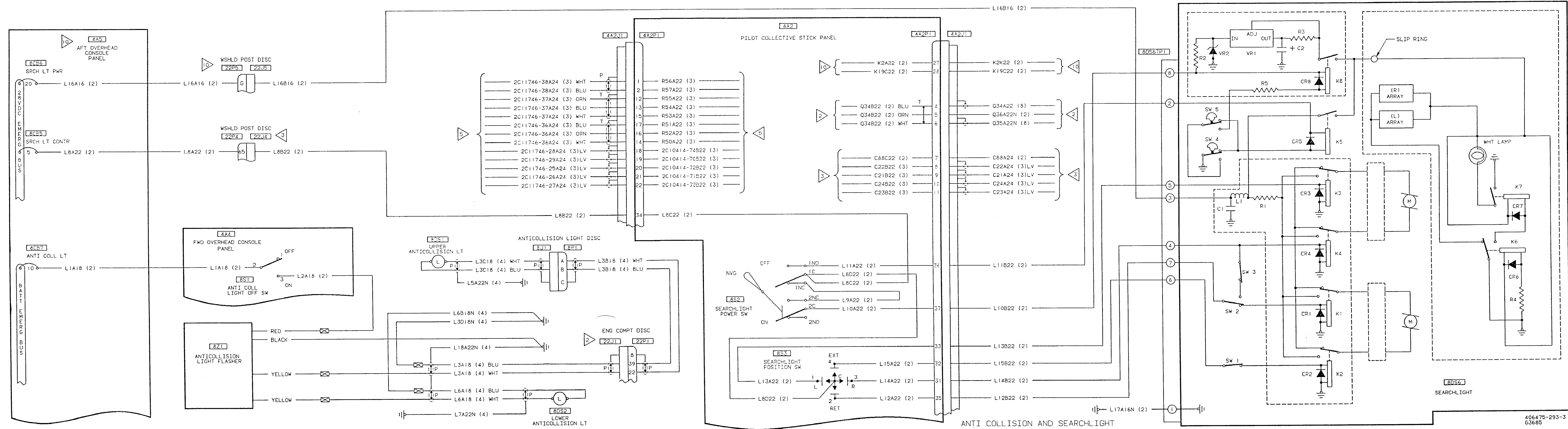
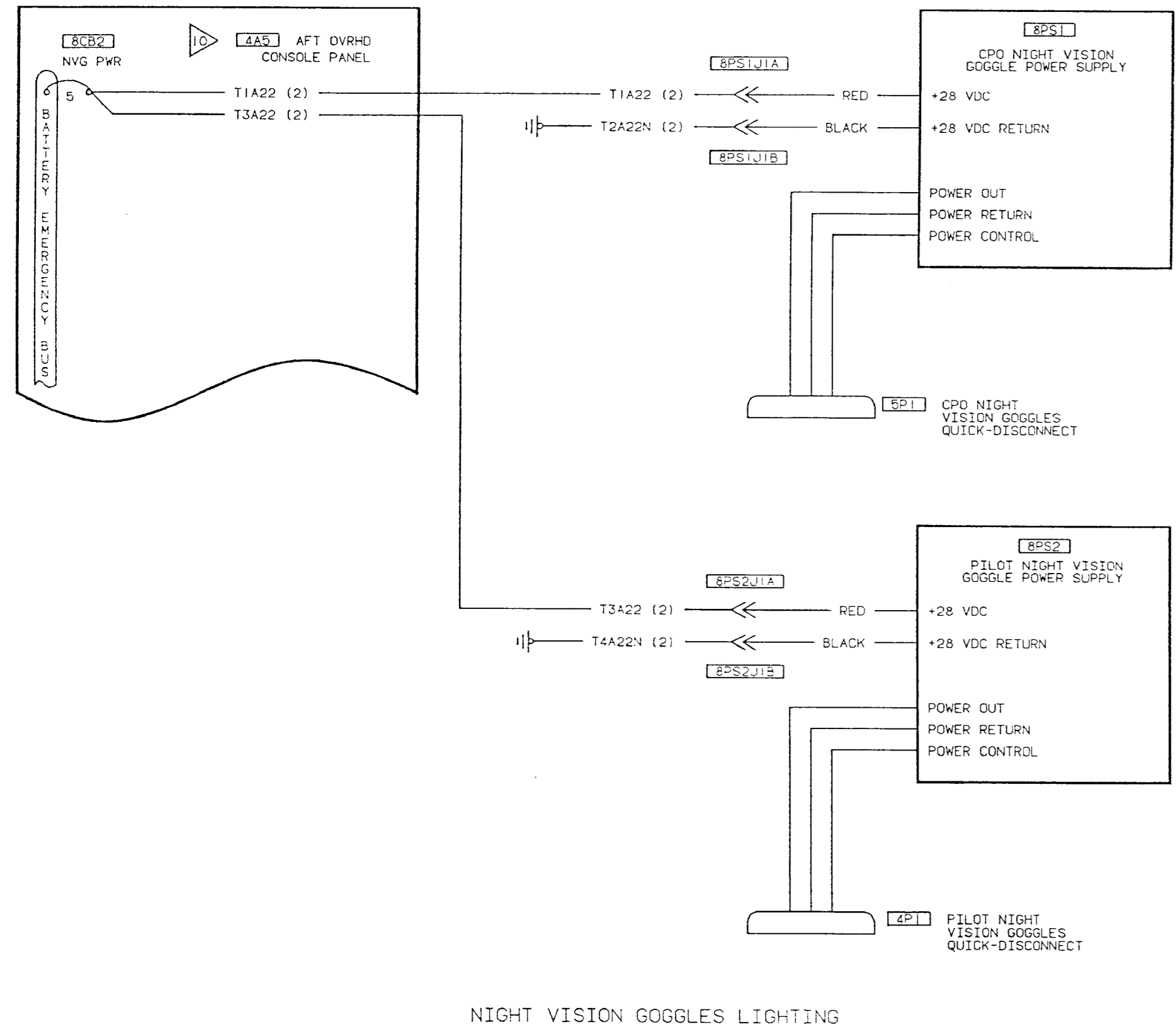
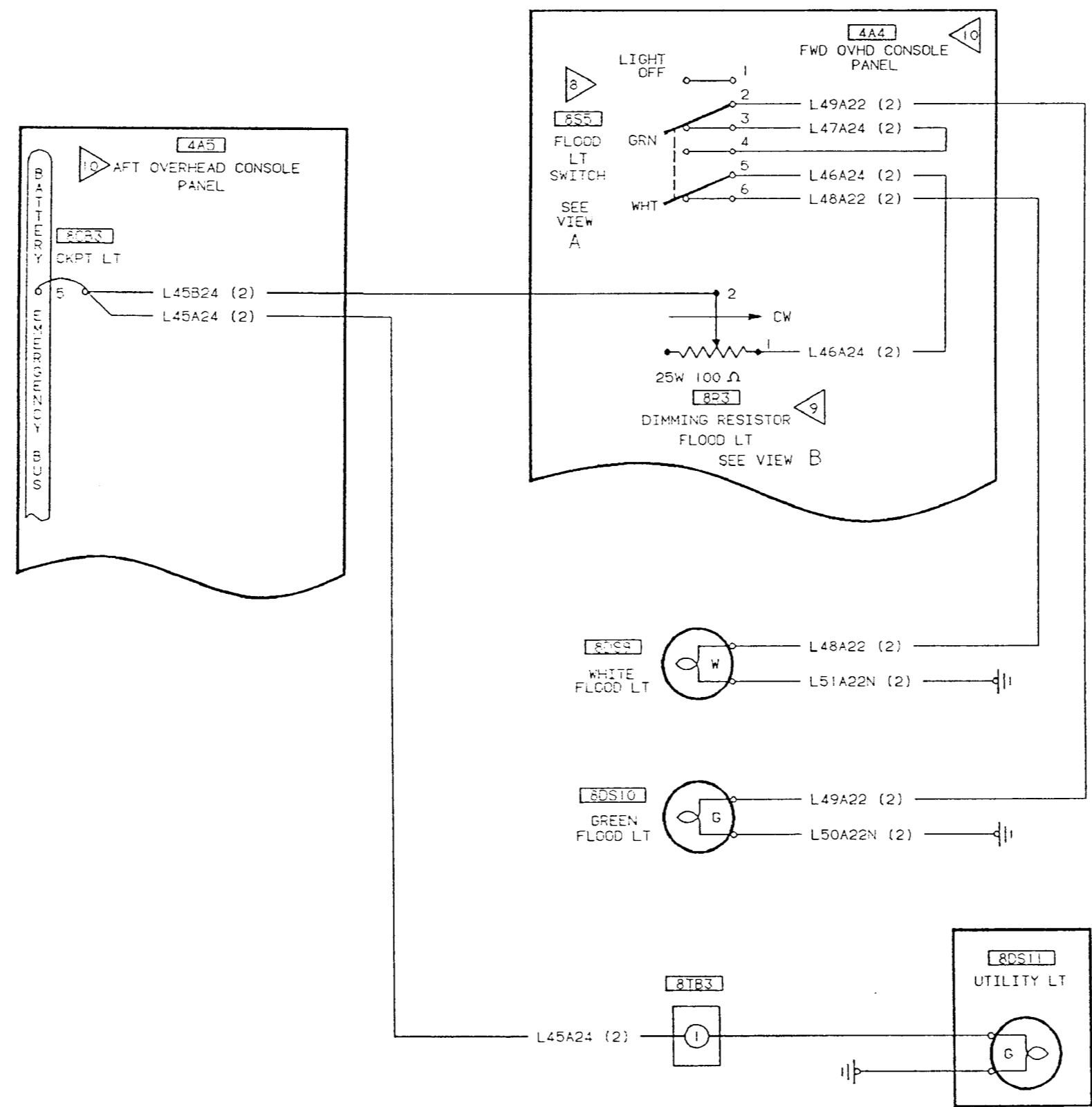

Figure FO-3. Lighting System Wiring Diagram (OH-58D) (Sheet 3 of 5)

406475-293-3
G3685



NIGHT VISION GOGGLES LIGHTING



UTILITY AND FLOOD LIGHTING

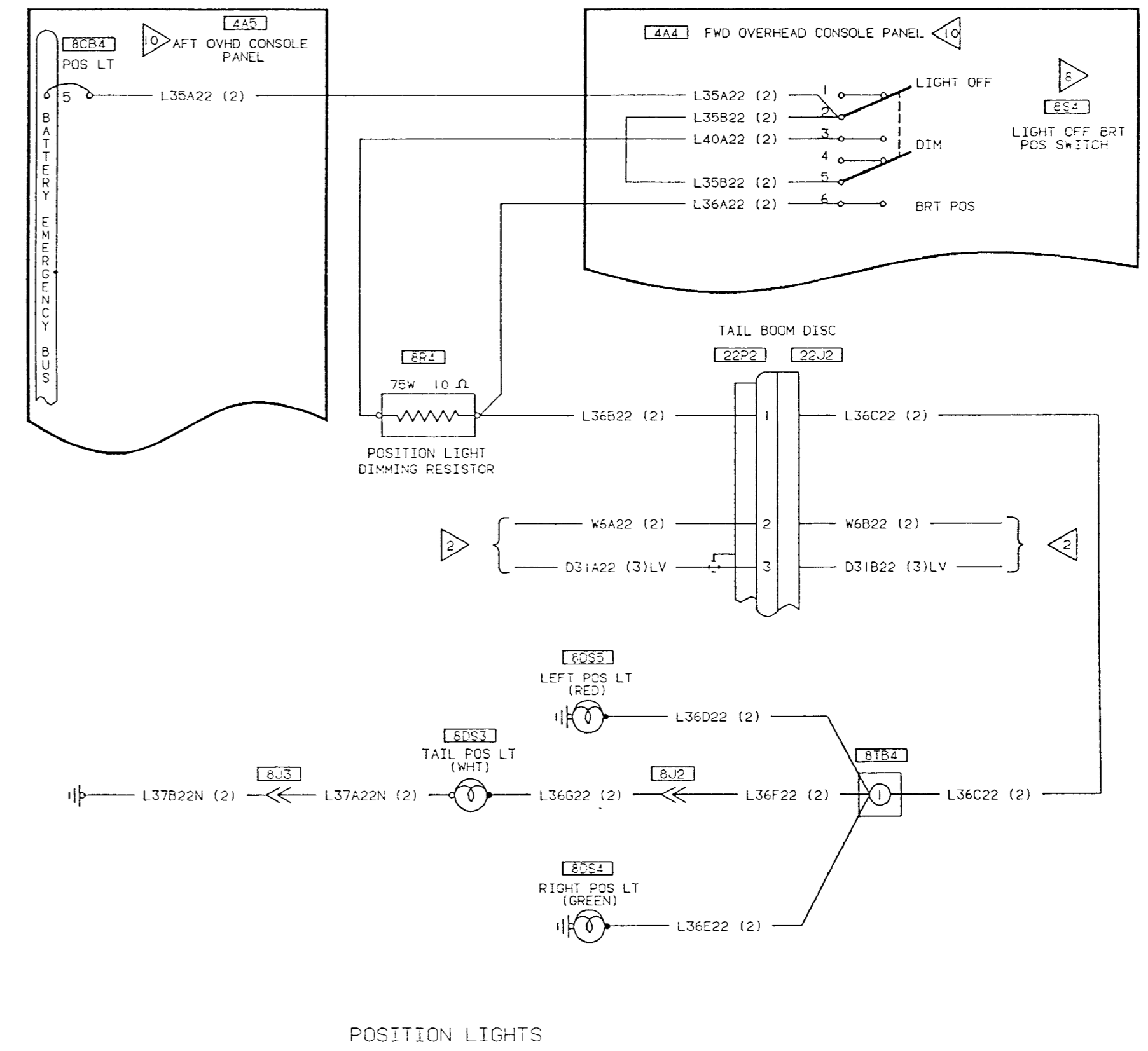

POSITION LIGHTS

Figure FO-3. Lighting System Wiring Diagram (OH-58D) (Sheet 4 of 5)

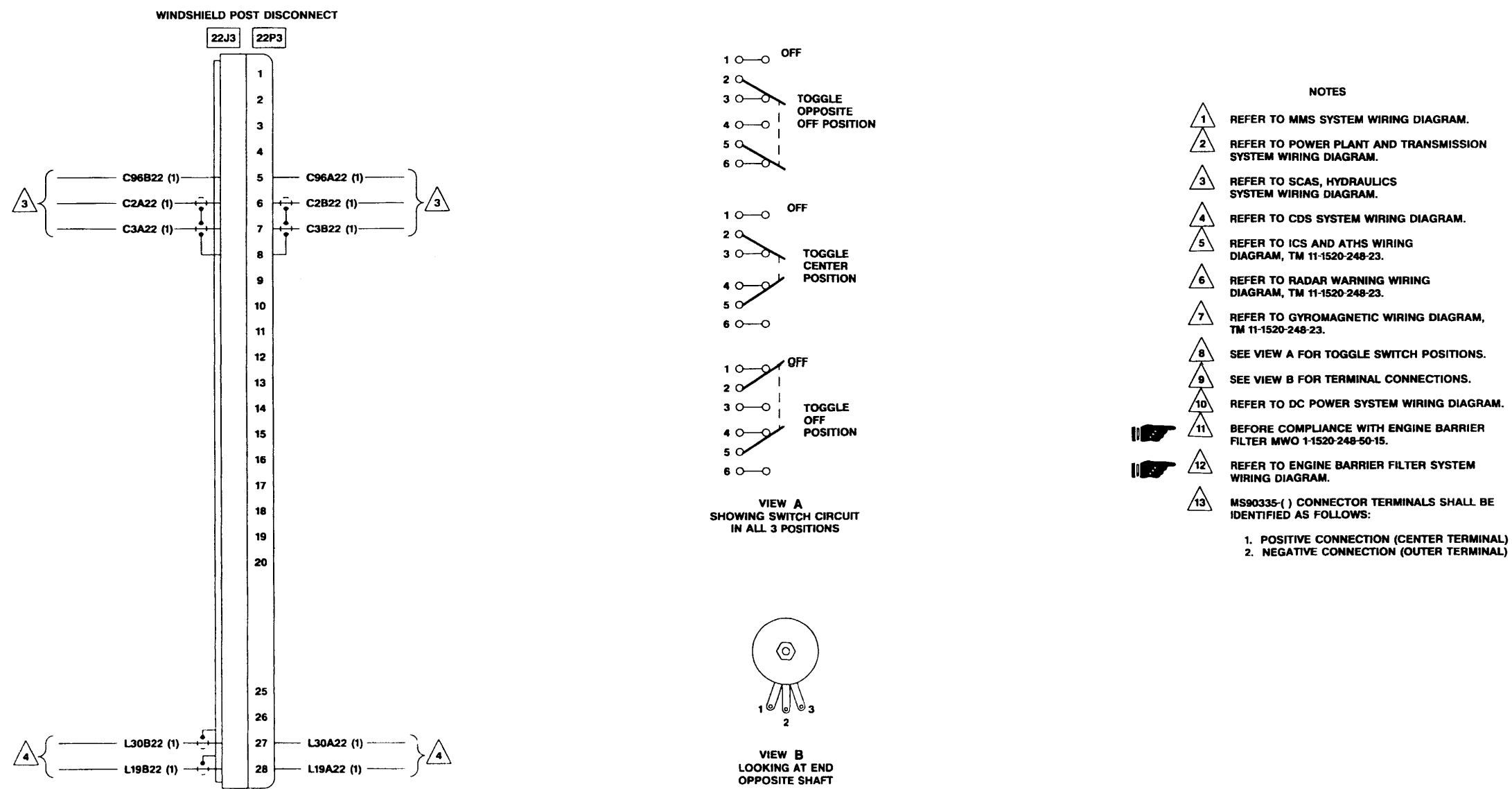

406475-544-6
J3238

Figure FO-3. Lighting System Wiring Diagram (OH-58D) (Sheet 5 of 5)

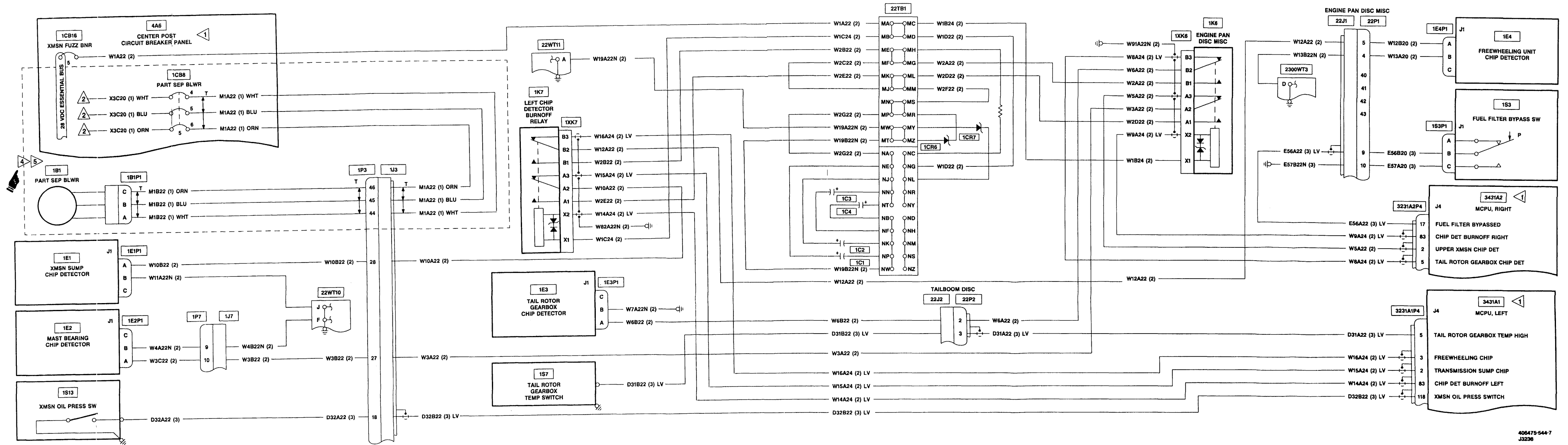

406475-544-7
J3236

Figure FO-4. Power Plant and Transmission System Wiring Diagram (OH-58D) (Sheet 1 of 8)

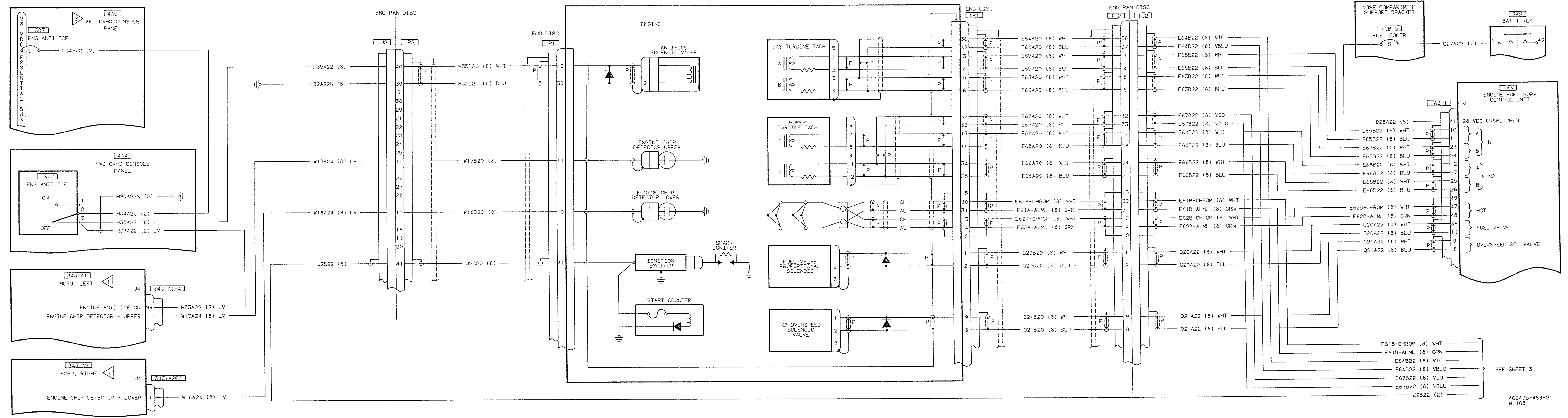

Figure FO-4. Power Plant and Transmission System Wiring Diagram (OH-58D) (Sheet 2 of 8)

406475-489-2
H1168

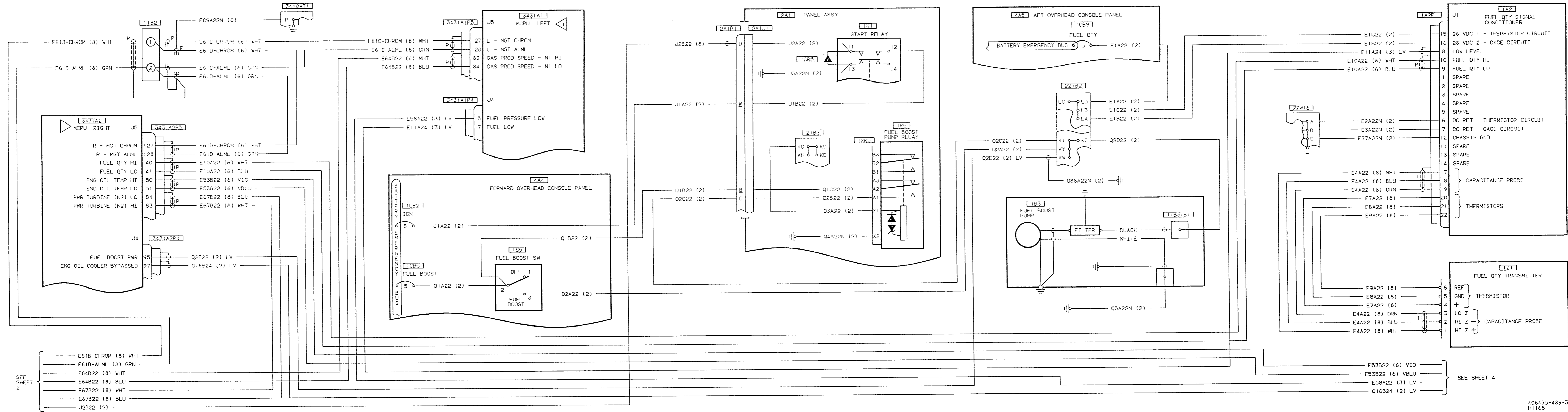

Figure FO-4. Power Plant and Transmission System Wiring Diagram (OH-58D) (Sheet 3 of 8)

406475-489-3
HI 168

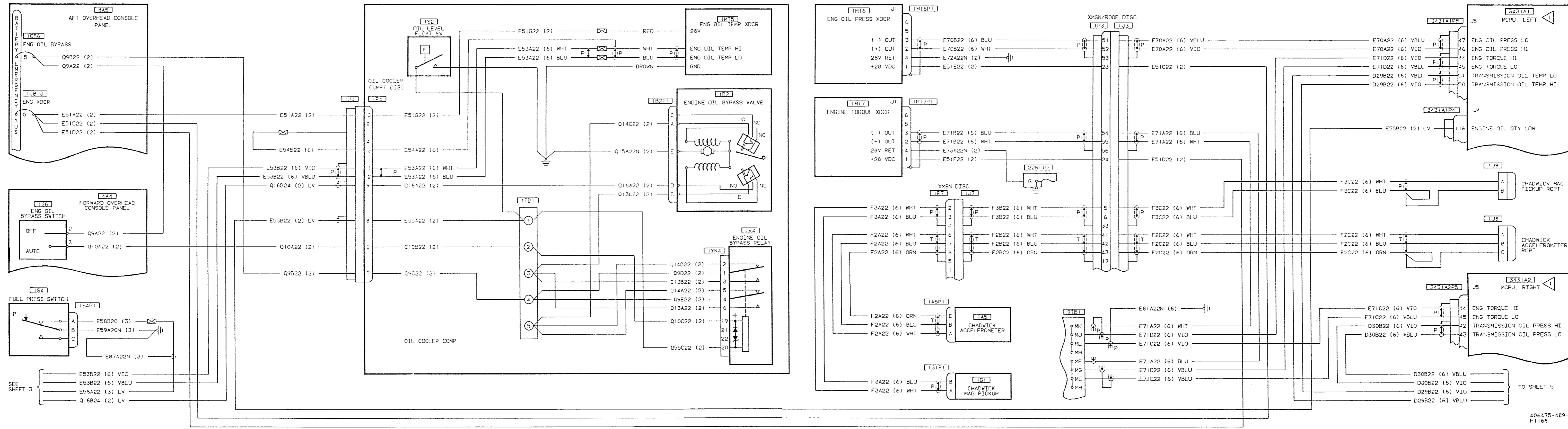

Figure FO-4. Power Plant and Transmission System Wiring Diagram (OH-58D) (Sheet 4 of 8)

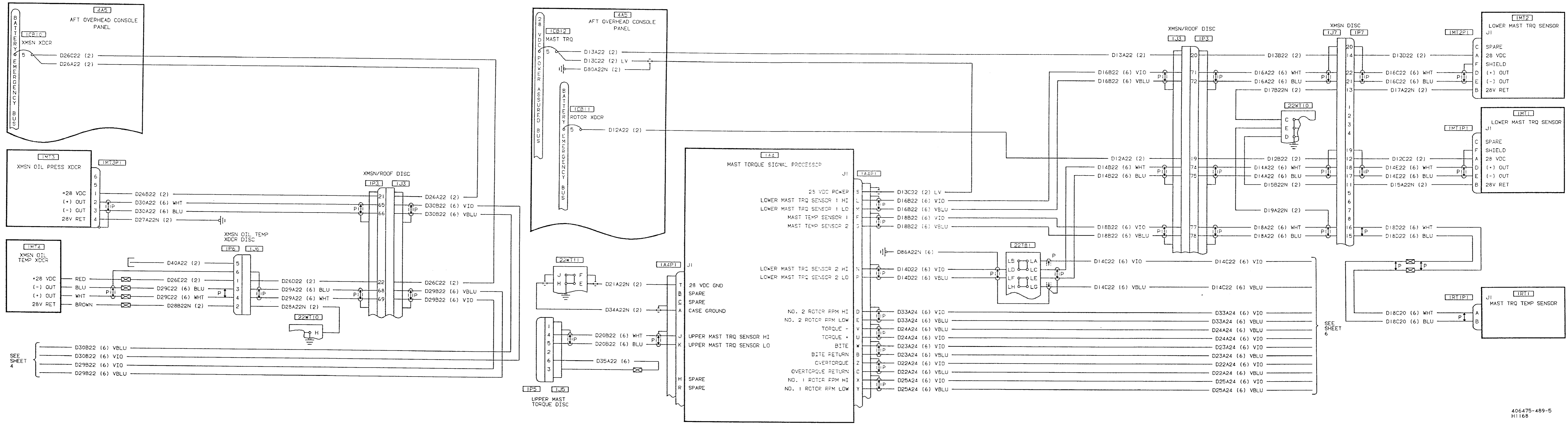

Figure FO-4. Power Plant and Transmission System Wiring Diagram (OH-58D) (Sheet 5 of 8)

406475-489-5
H1168

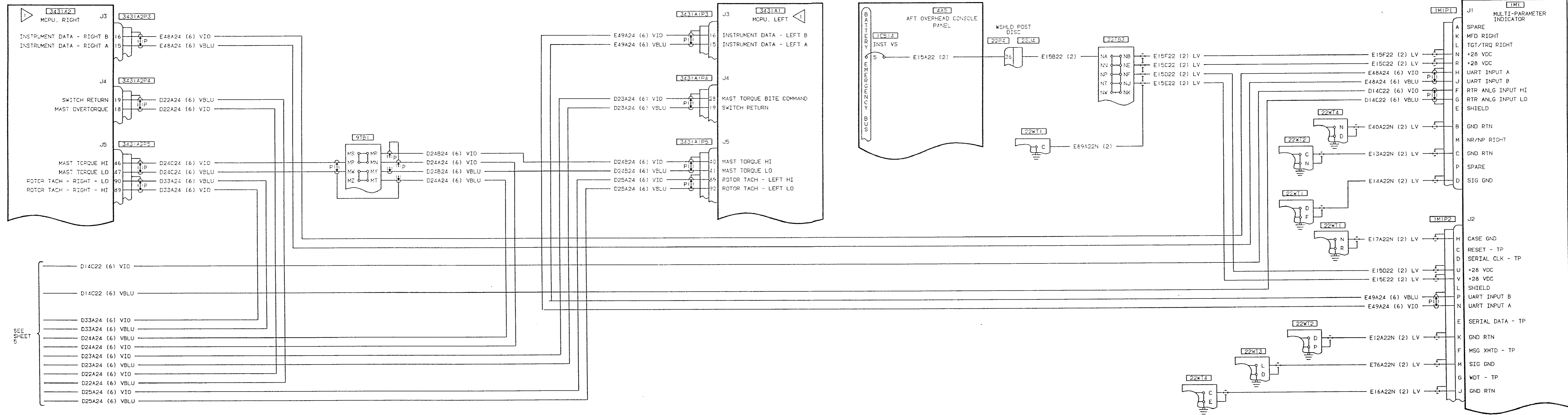

Figure FO-4. Power Plant and Transmission System Wiring Diagram (OH-58D) (Sheet 6 of 8)

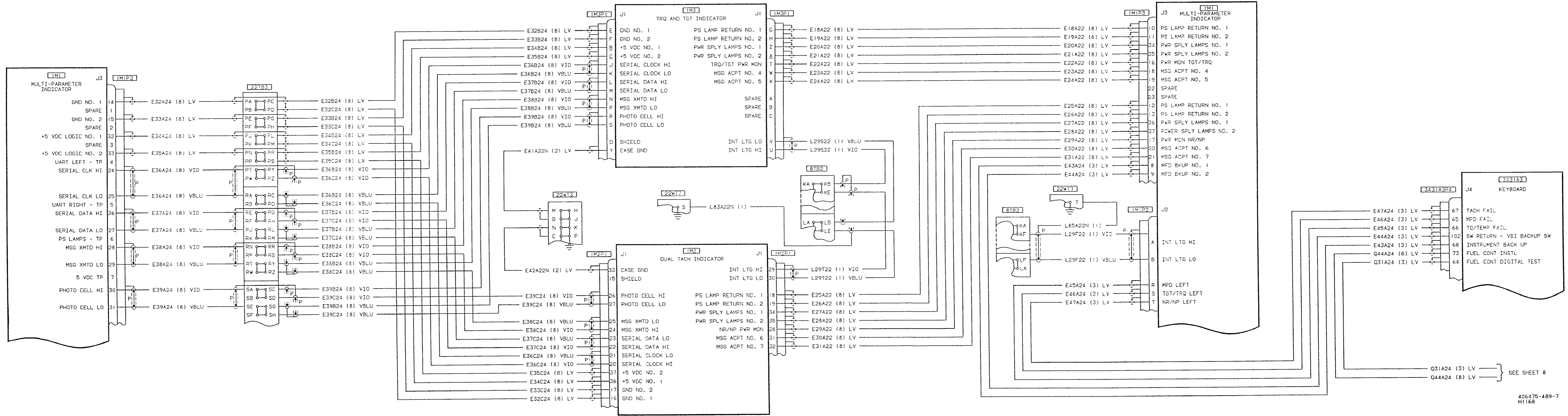

Figure FO-4. Power Plant and Transmission System Wiring Diagram (OH-58D) (Sheet 7 of 8)

406475-489-7
H1168

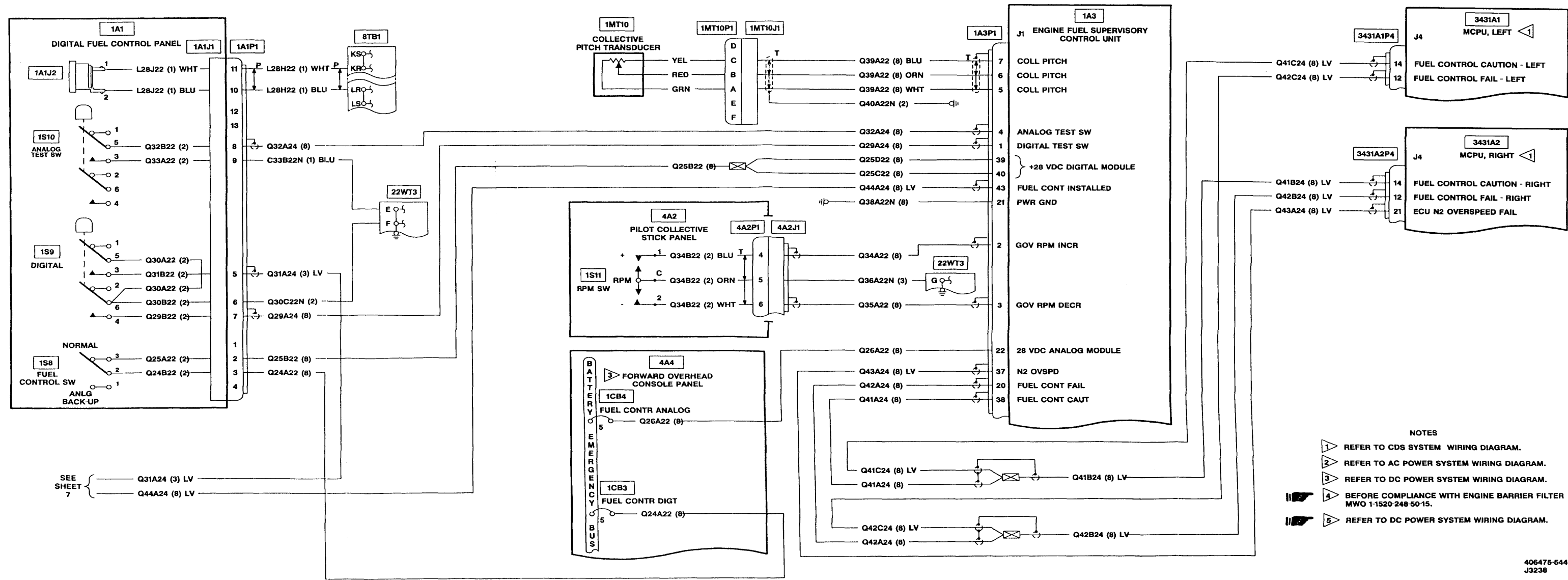

Figure FO-4. Power Plant and Transmission System Wiring Diagram (OH-58D) (Sheet 8 of 8)

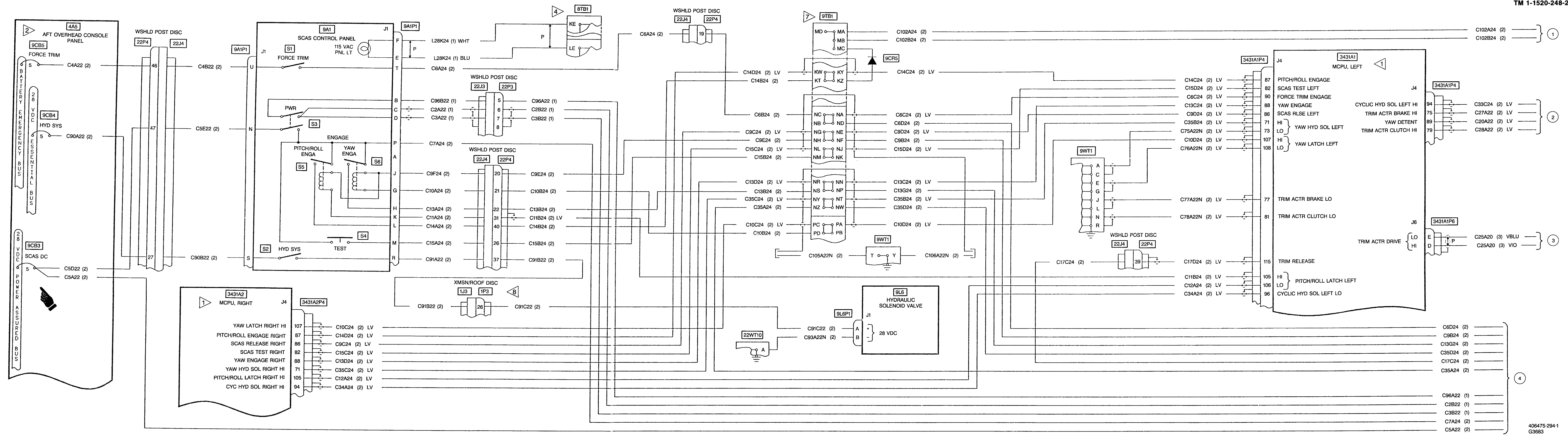
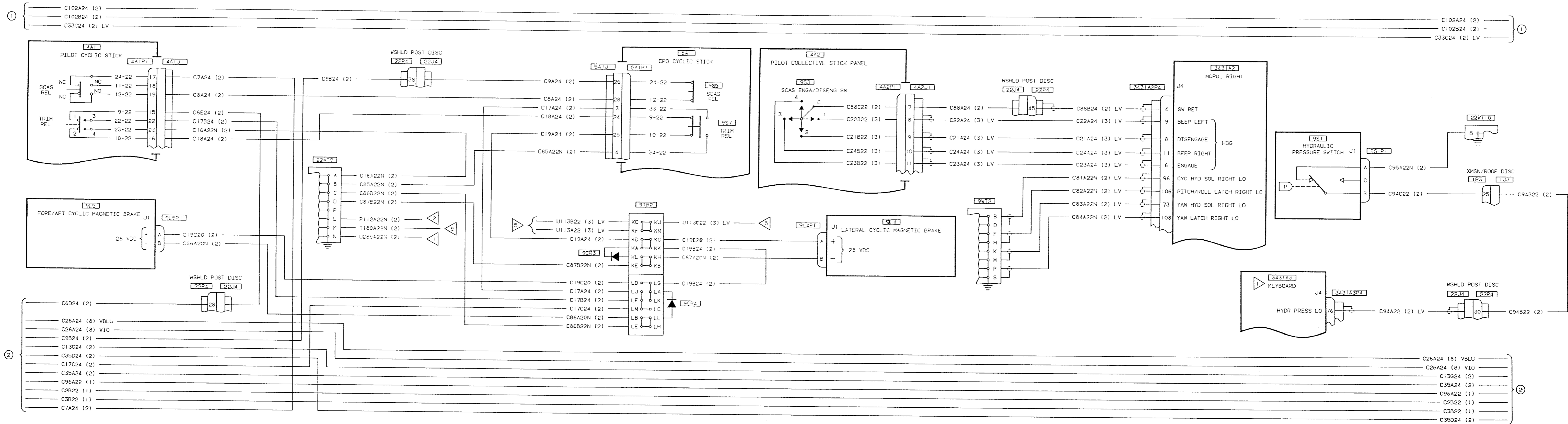

Figure FO-5. SCAS, Hydraulic, and Standby Attitude Gyro System Wiring Diagram (OH-58D)
(Sheet 1 of 7)

406475-294-1
G3683



406475-294-3
G3683

Figure FO-5. SCAS, Hydraulic, and Standby Attitude Gyro System Wiring Diagram (OH-58D)
(Sheet 3 of 7)

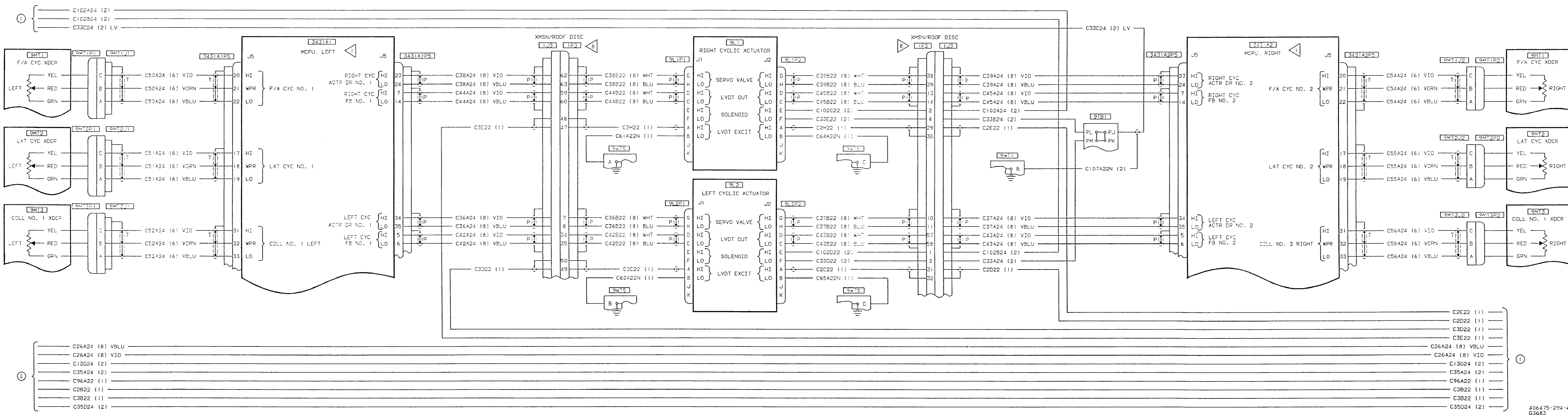
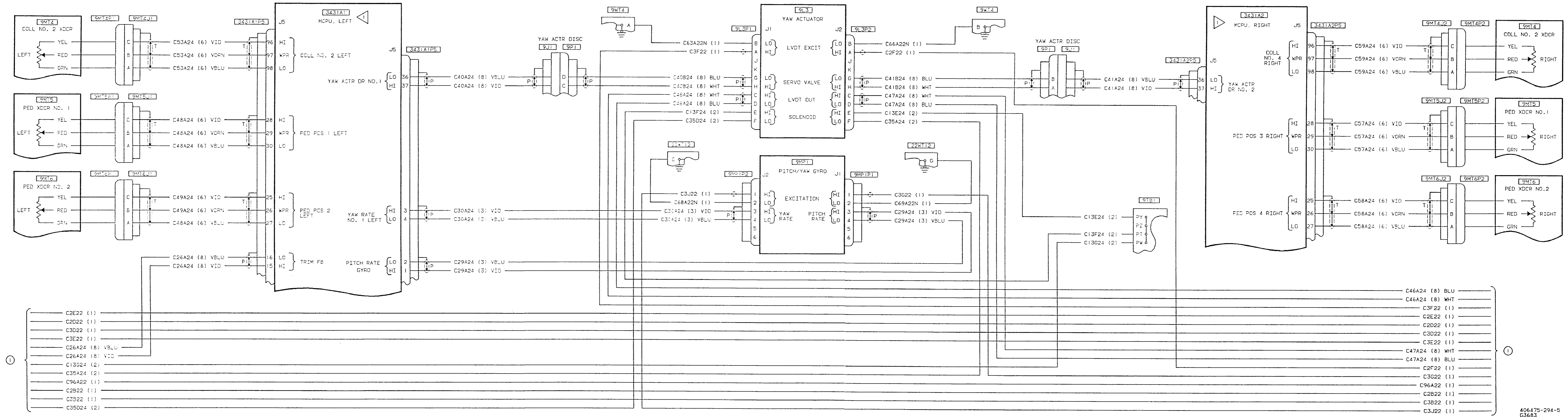

Figure FO-5. SCAS, Hydraulic, and Standby Attitude Gyro System Wiring Diagram (OH-58D) (Sheet 4 of 7)

406475-294-4
G3683



406475-294-5
G3683

Figure FO-5. SCAS, Hydraulic, and Standby Attitude Gyro System Wiring Diagram (OH-58D)
(Sheet 5 of 7)

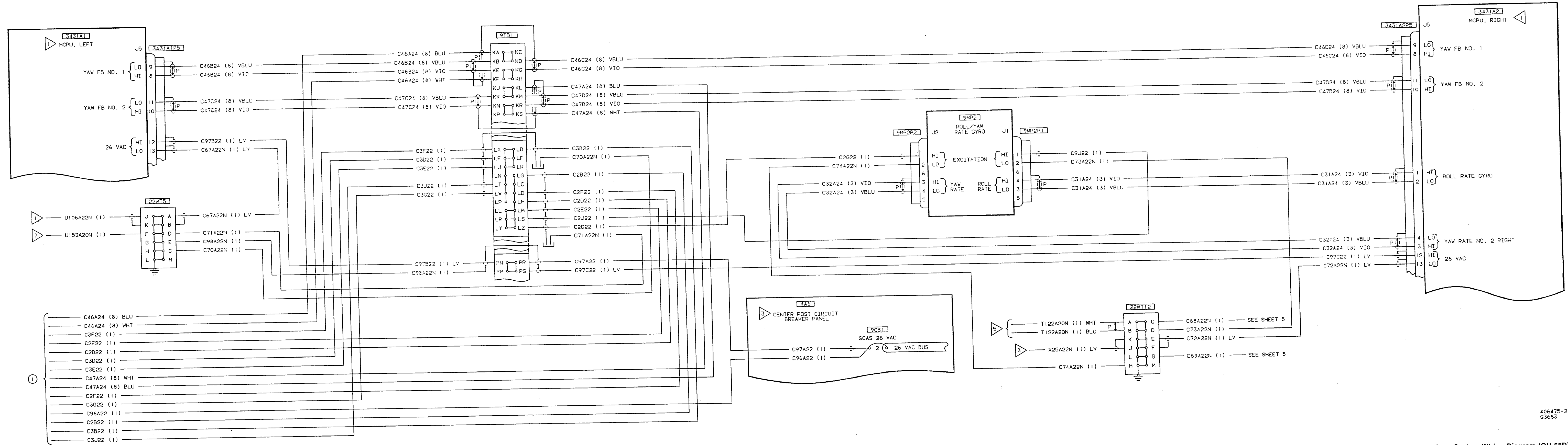
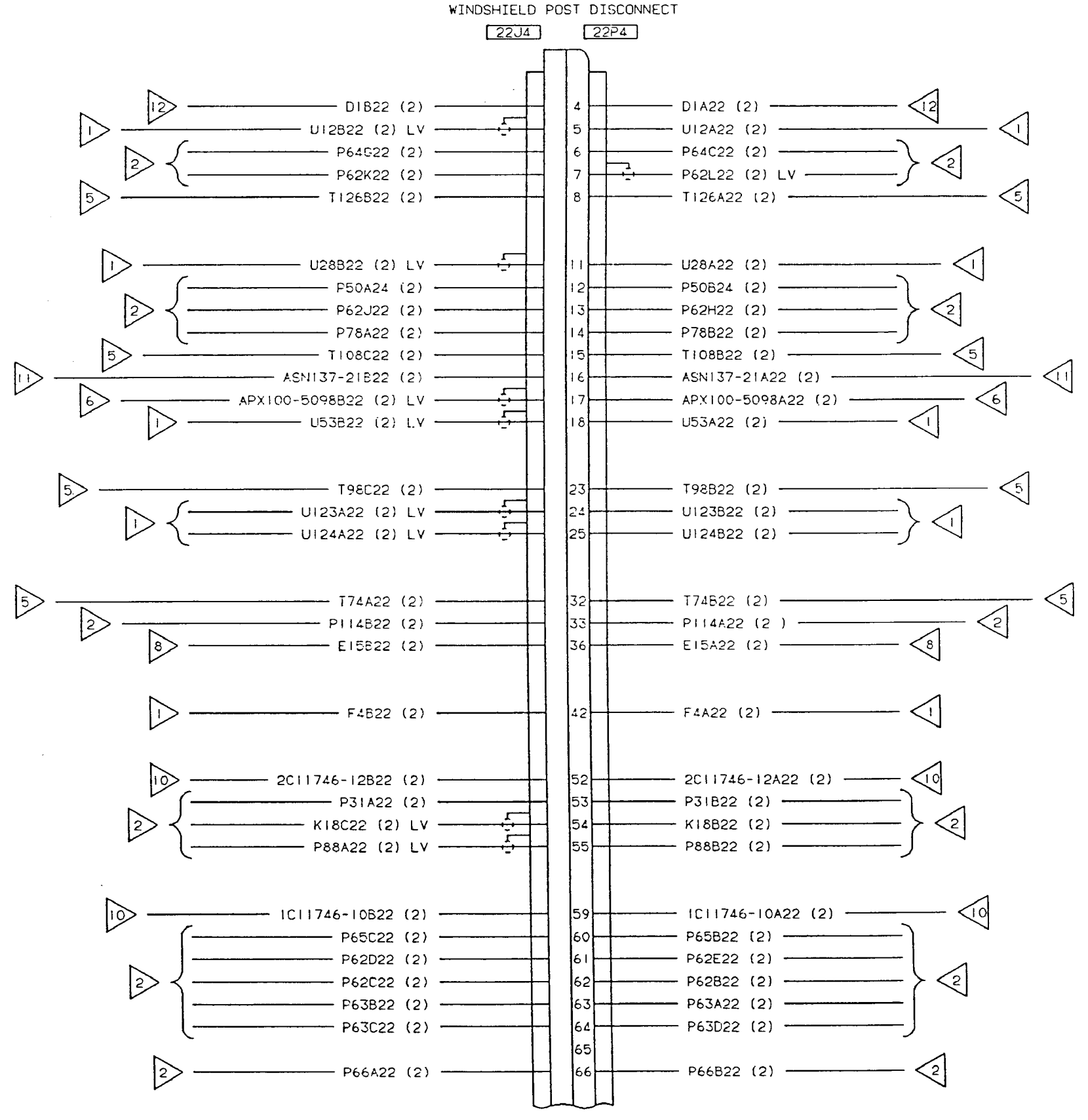
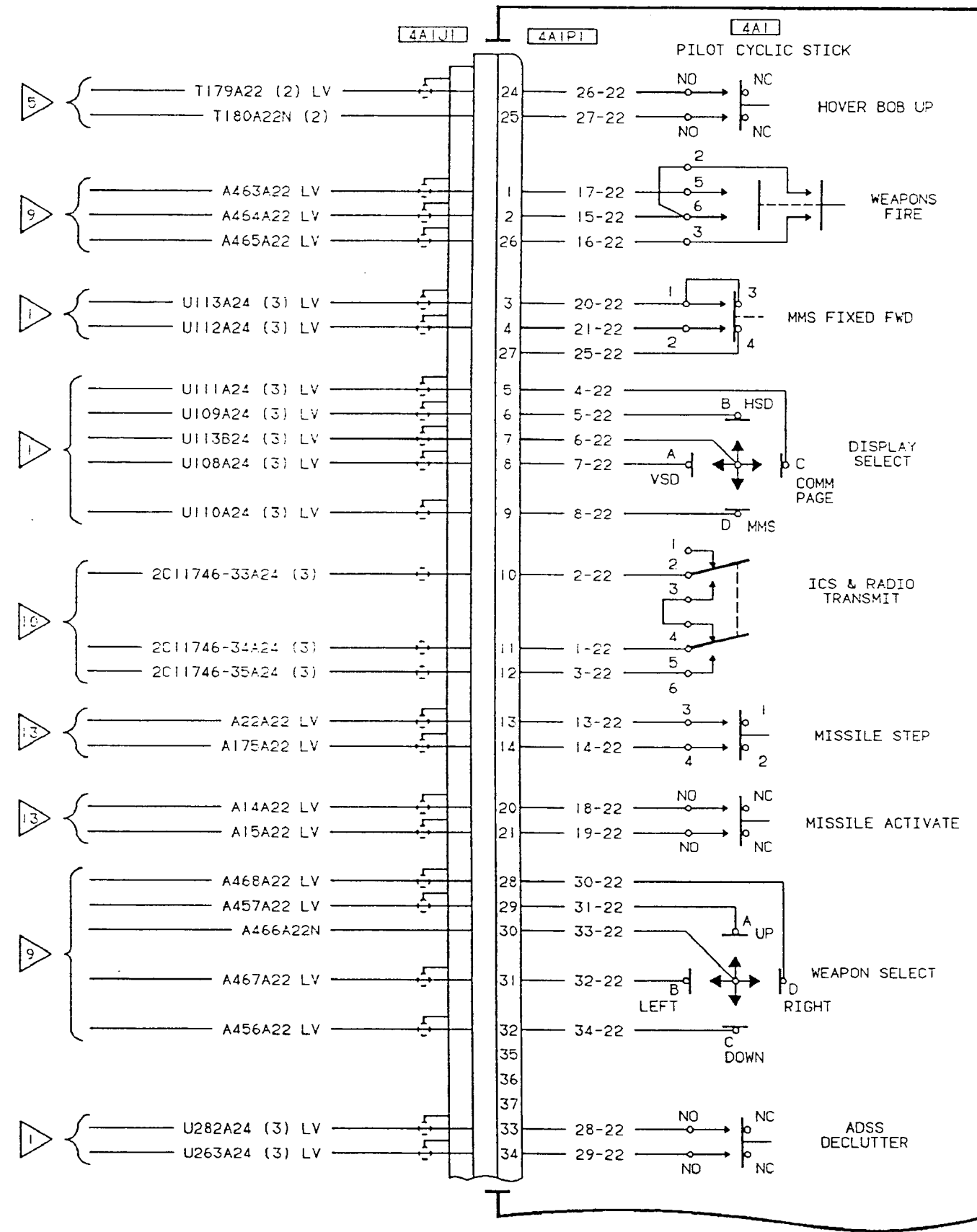

Figure FO-5. SCAS, Hydraulic, and Standby Attitude Gyro System Wiring Diagram (OH-58D) (Sheet 6 of 7)

406475-294-6
G3683



- NOTES
- 1 REFER TO CDS SYSTEM WIRING DIAGRAM.
 - 2 REFER TO DC POWER SYSTEM WIRING DIAGRAM.
 - 3 REFER TO AC POWER SYSTEM WIRING DIAGRAM.
 - 4 REFER TO LIGHTING SYSTEM WIRING DIAGRAM.
 - 5 REFER TO MMS SYSTEM WIRING DIAGRAM.
 - 6 REFER TO AN/APX100 IFF SYSTEM WIRING DIAGRAM TM 11-1520-248-23.
 - 7 REFER TO AHRS SYSTEM WIRING DIAGRAM TM 11-1520-248-23.
 - 8 REFER TO POWER PLANT AND TRANSMISSION WIRING DIAGRAM.
 - 9 REFER TO GUNS AND ROCKETS SYSTEM WIRING DIAGRAM.
 - 10 REFER TO ICS WIRING DIAGRAM TM 11-1520-248-23.
 - 11 REFER TO DOPPLER NAVIGATION WIRING DIAGRAM TM 11-1520-248-23.
 - 12 REFER TO ADS WIRING DIAGRAM.
 - 13 REFER TO ATAS WIRING DIAGRAM.
 - 14 NUMBERED CIRCLE ON RIGHT SIDE OF SHEET SIGNIFIES "GO TO NEXT SHEET" AND FIND SAME NUMBER ON LEFT SIDE OF SHEET WITH MATCHING WIRE NUMBER(S).

Figure FO-5. SCAS, Hydraulic, and Standby Attitude Gyro System Wiring Diagram (OH-58D) (Sheet 7 of 7)

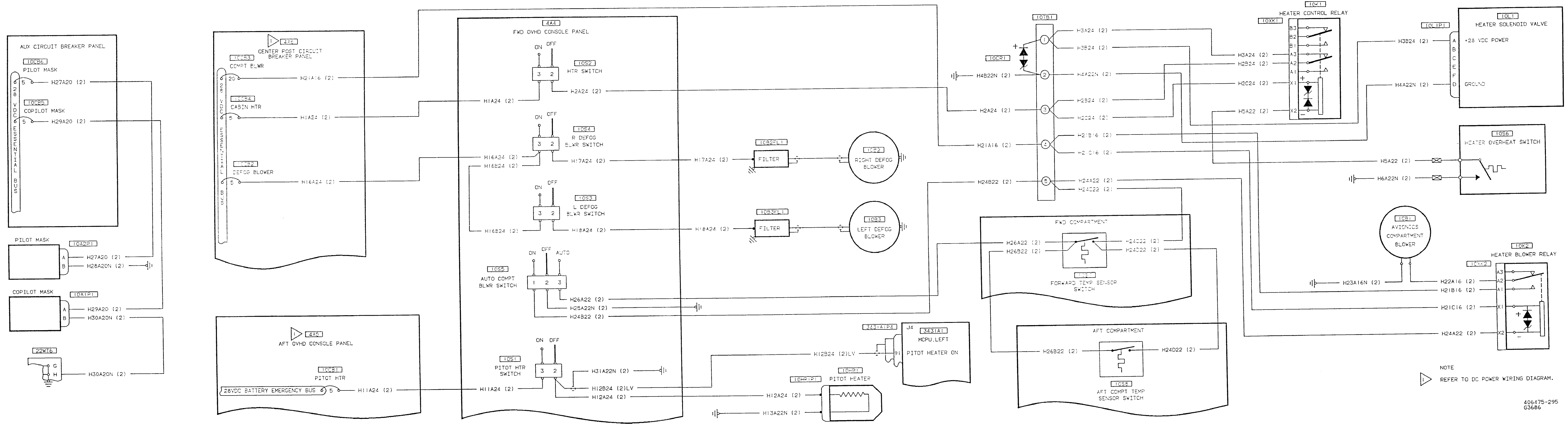

NOTE
 REFER TO DC POWER WIRING DIAGRAM.

406475-295
 63686

Figure FO-6. Environmental Electrical System Wiring Diagram (OH-58D)

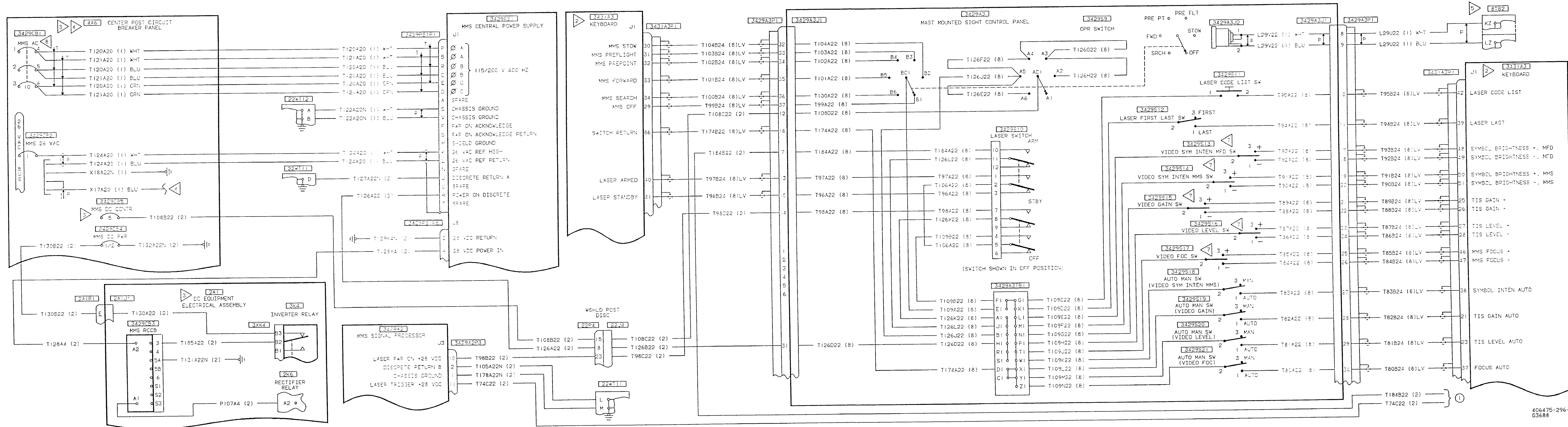

406475-296-1
G3688

Figure FO-7. Mast Mounted Sight (MMS) System Wiring Diagram (OH-58D) (Sheet 1 of 4)

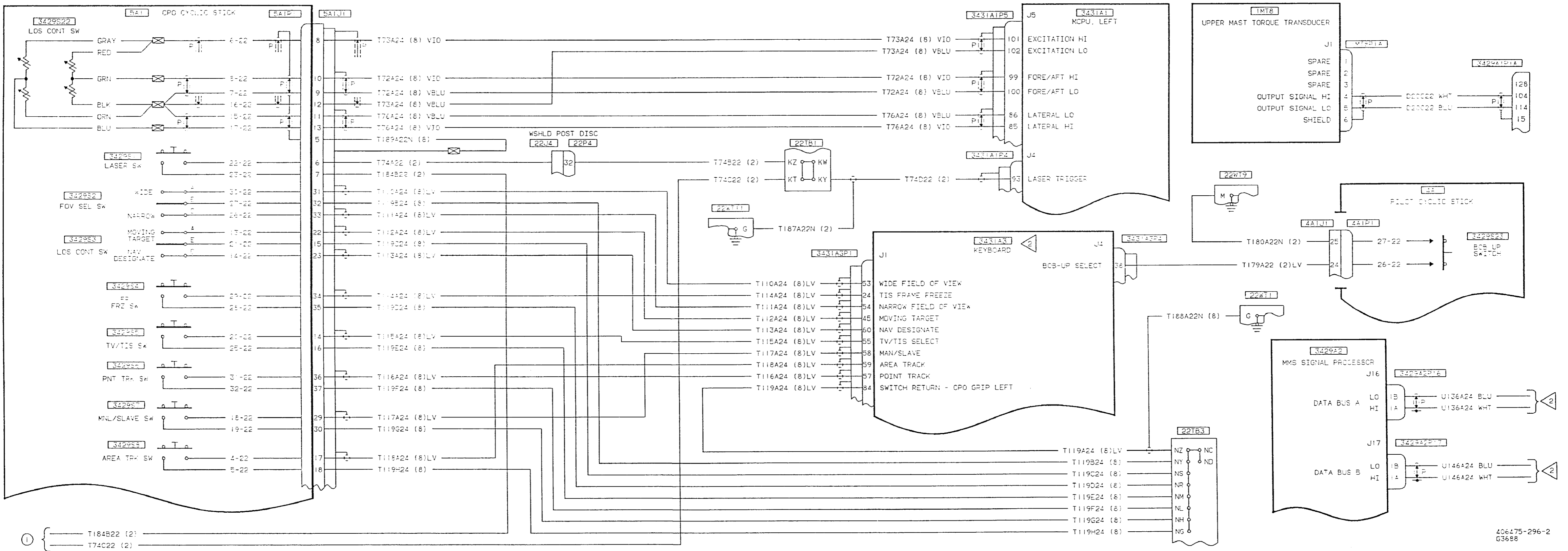

Figure FO-7. Mast Mounted Sight (MMS) System Wiring Diagram (OH-58D) (Sheet 2 of 4)

406475-296-2
G3688

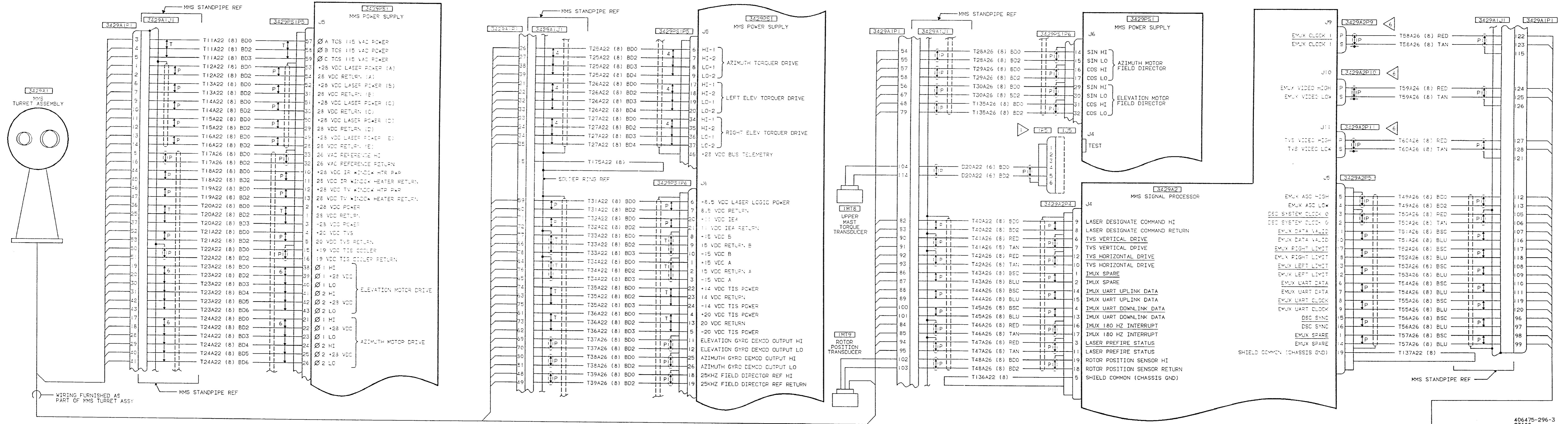

Figure FO-7. Mast Mounted Sight (MMS) System Wiring Diagram (OH-58D) (Sheet 3 of 4)

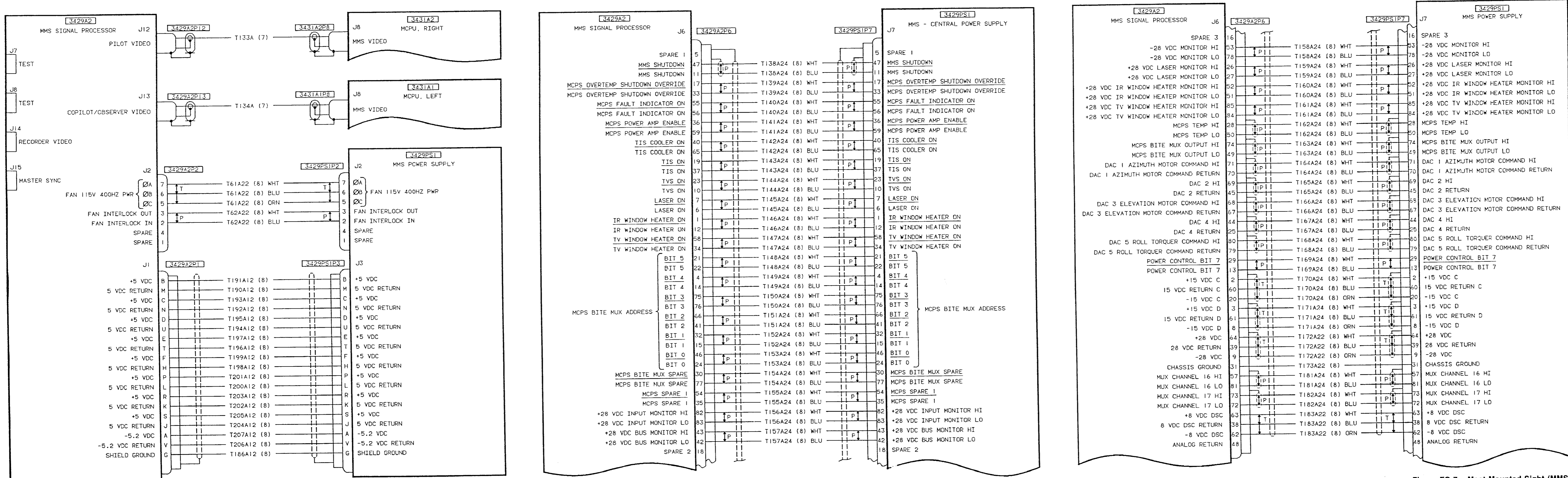
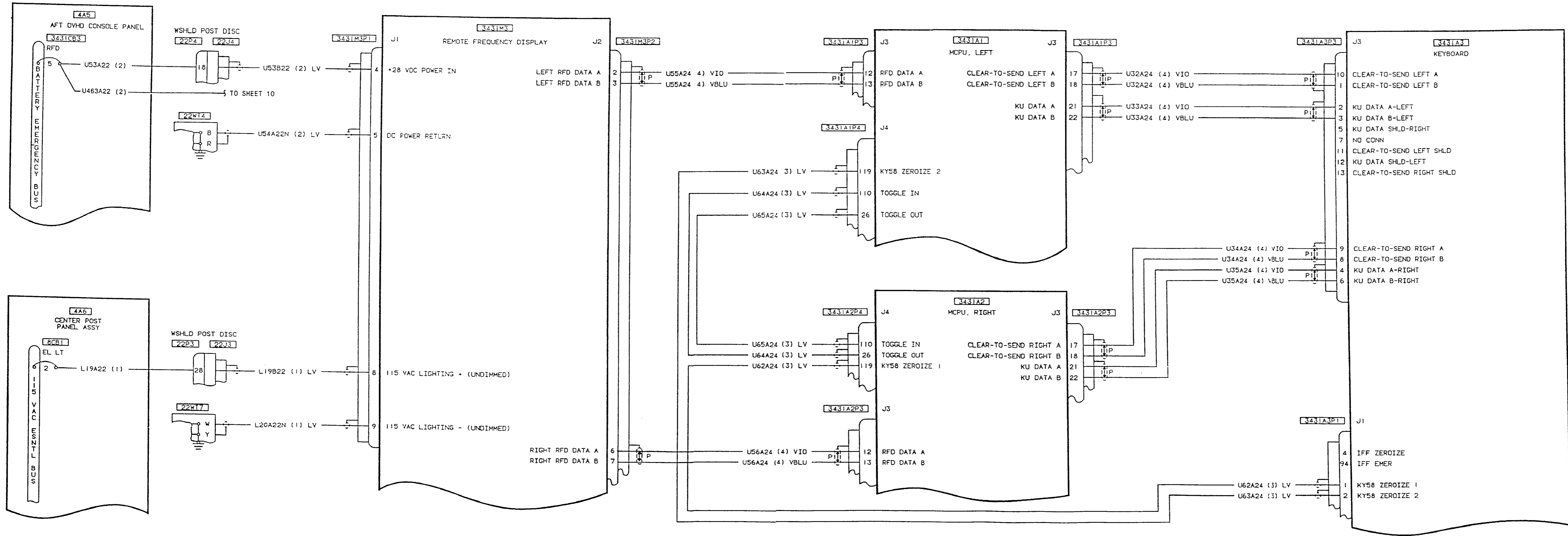

Figure FO-7. Mast Mounted Sight (MMS) System Wiring Diagram (OH-58D) (Sheet 4 of 4)



406475-519-1 H5368

Figure FO-8. Control Display System (CDS) Wiring Diagram (OH-58D) (Sheet 1 of 10)

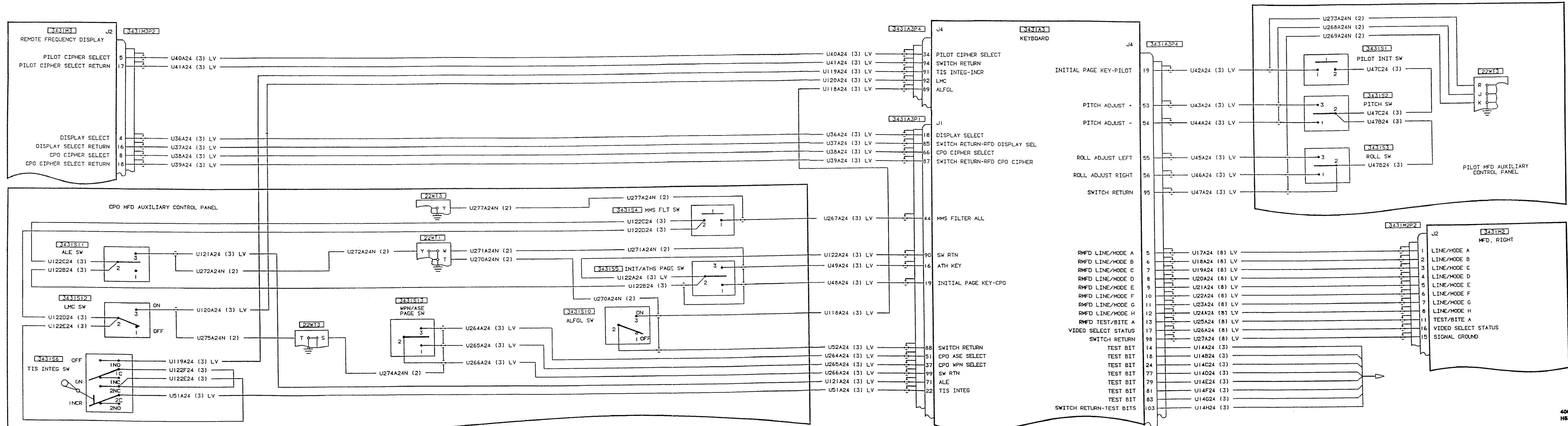

Figure FO-8. Control Display System (CDS) Wiring Diagram (OH-58D) (Sheet 2 of 10)

406475-519-2 H6388

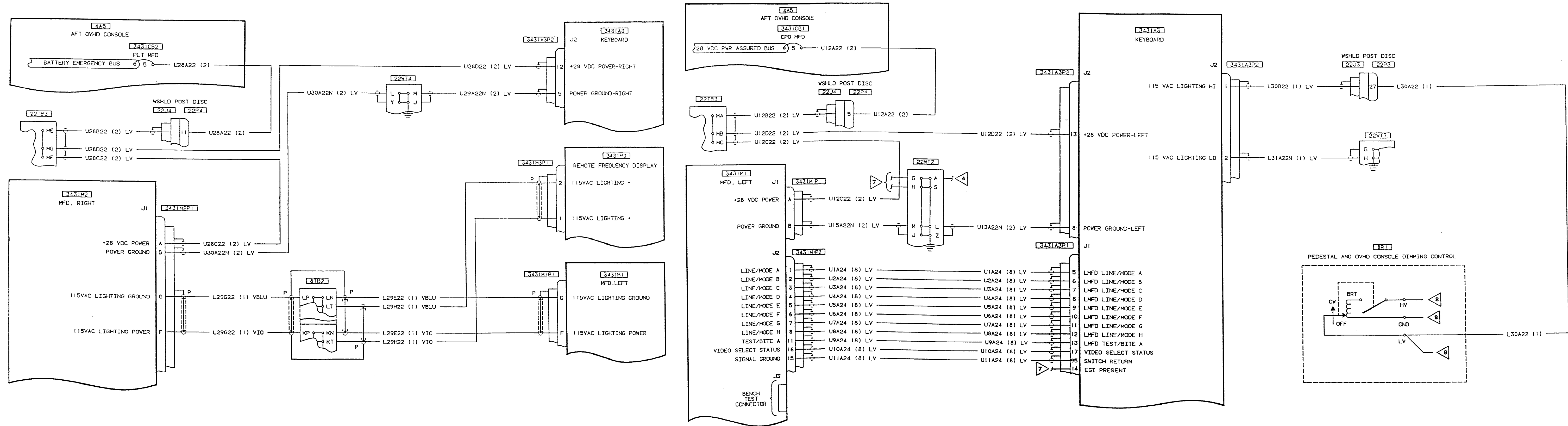
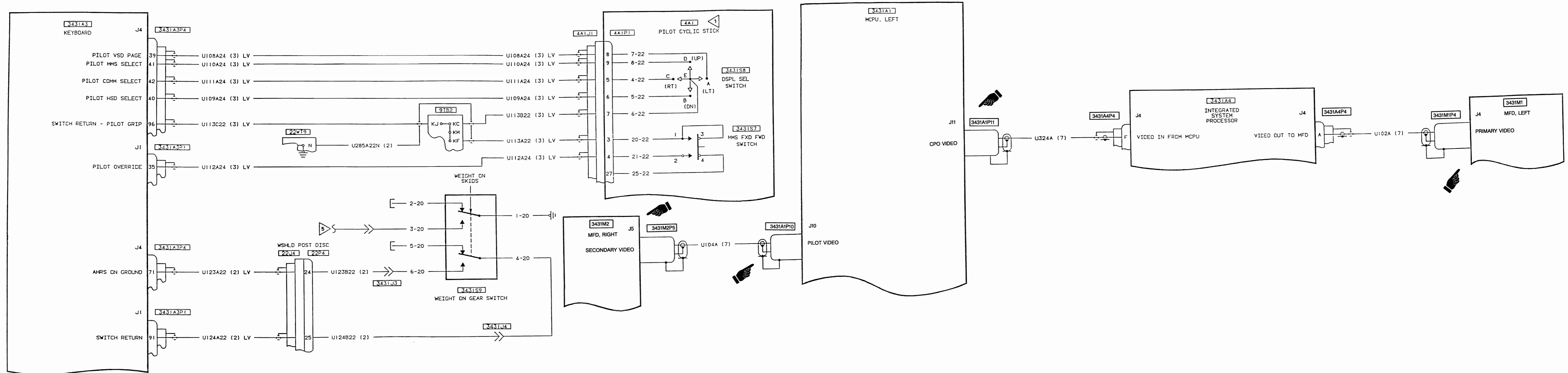

Figure FO-8. Control Display System (CDS) Wiring Diagram (OH-58D) (Sheet 3 of 10)

406475-519-3
H5368



406475-519-4
H6368

Figure FO-8. Control Display System (CDS) Wiring Diagram (OH-58D) (Sheet 4 of 10)

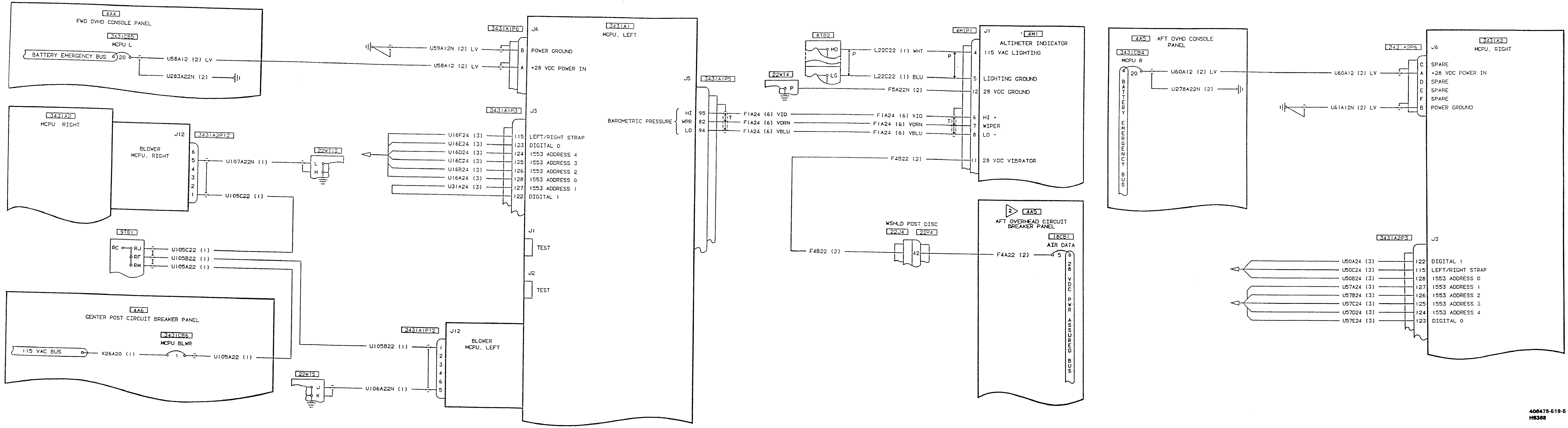

406475-519-5
H8388

Figure FO-8. Control Display System (CDS) Wiring Diagram (OH-58D) (Sheet 5 of 10)

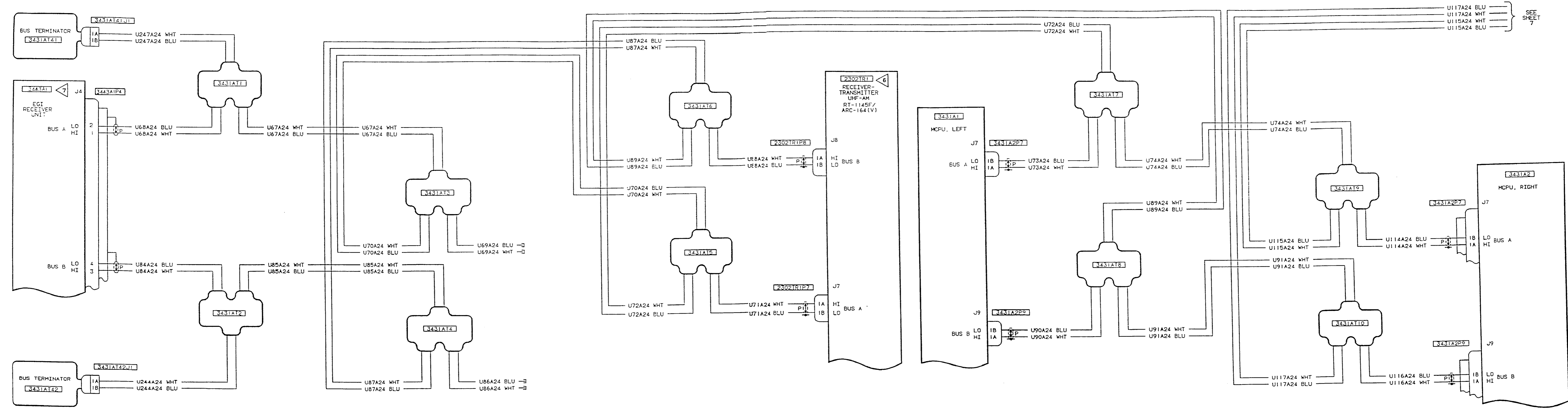

408475-519-6
H8388

Figure FO-8. Control Display System (CDS) Wiring Diagram (OH-58D) (Sheet 6 of 10)

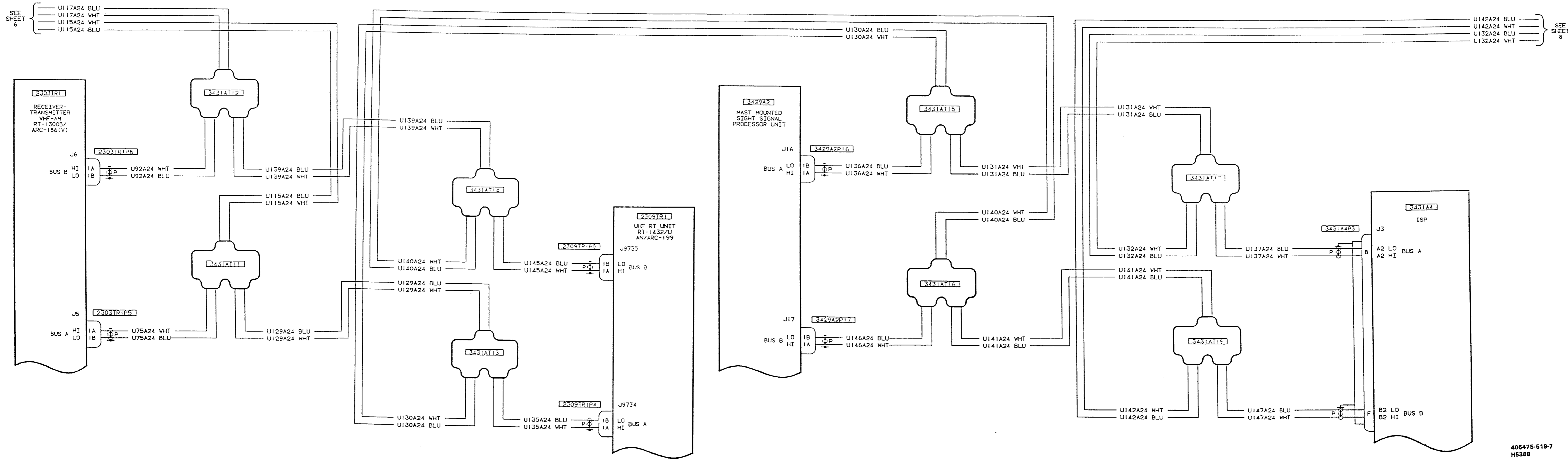

Figure FO-8. Control Display System (CDS) Wiring Diagram (OH-58D) (Sheet 7 of 10)

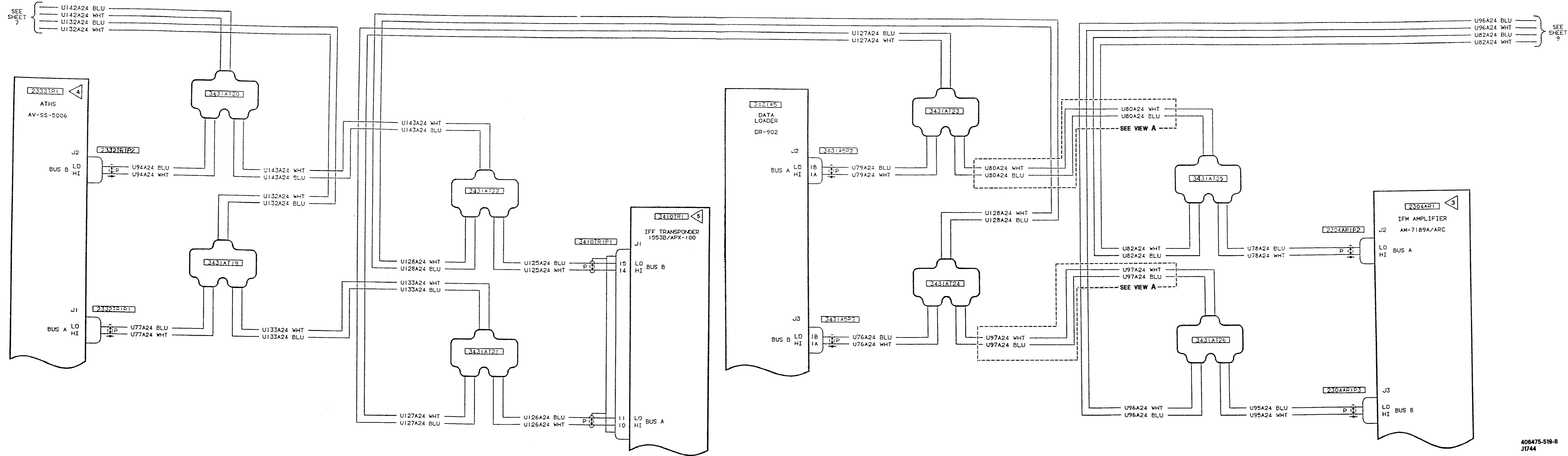

Figure FO-8. Control Display System (CDS) Wiring Diagram (OH-58D) (Sheet 8 of 10)

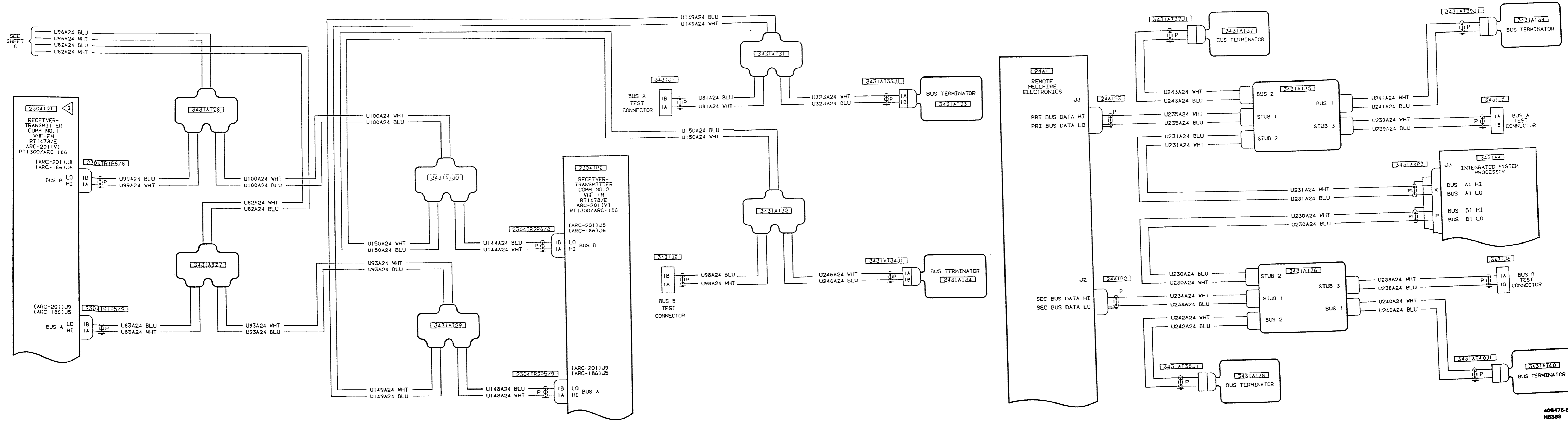

Figure FO-8. Control Display System (CDS) Wiring Diagram (OH-58D) (Sheet 9 of 10)

406475-518-9
H5368

- NOTES**
- 1 REFER TO SCAS, HYDRAULIC, AND STANDBY ATTITUDE GYRO SYSTEM WIRING DIAGRAM.
 - 2 REFER TO AIR DATA SUBSYSTEM WIRING DIAGRAM.
 - 3 REFER TO NO. 1 VHF-FM WIRING DIAGRAM TM 11-1520-248-23.
 - 4 REFER TO INTERCOM AND ATHS WIRING DIAGRAM TM 11-1520-248-23.
 - 5 REFER TO IFF (AN/APX-100) WIRING DIAGRAM TM 11-1520-248-23.
 - 6 REFER TO UHF-AM COMM (AN/ARC-164) WIRING DIAGRAM TM 11-1520-248-23.
 - 7 REFER TO EMBEDDED GLOBAL POSITIONING/INERTIAL NAVIGATION (EGI) SYSTEM WIRING DIAGRAM TM 11-1520-248-23.
 - 8 REFER TO LIGHTING SYSTEM WIRING DIAGRAM.
 - 9 REFER TO NO. 2 VHF-FM WIRING DIAGRAM TM 11-1520-248-23.
 - 10 REFER TO HF WIRING DIAGRAM TM 11-1520-248-23.
 - 11 FOR HELICOPTERS EQUIPPED WITH TACAN.
 - 12 REFER TO TACAN WIRING DIAGRAM TM 11-1520-248-23.

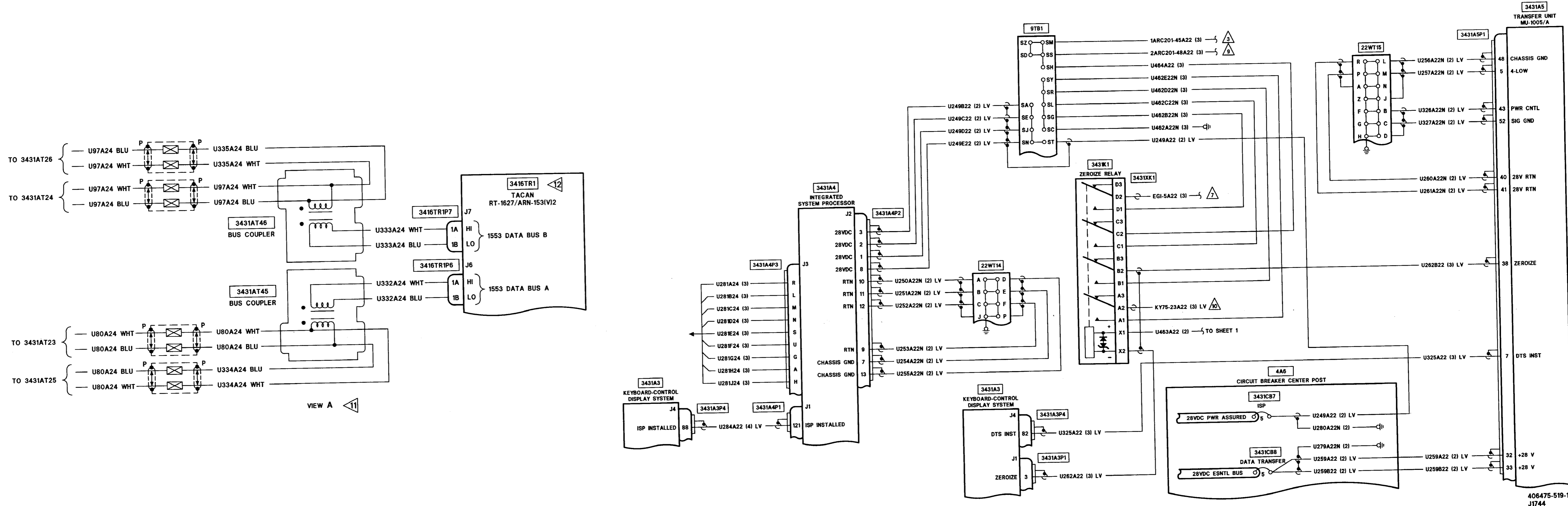
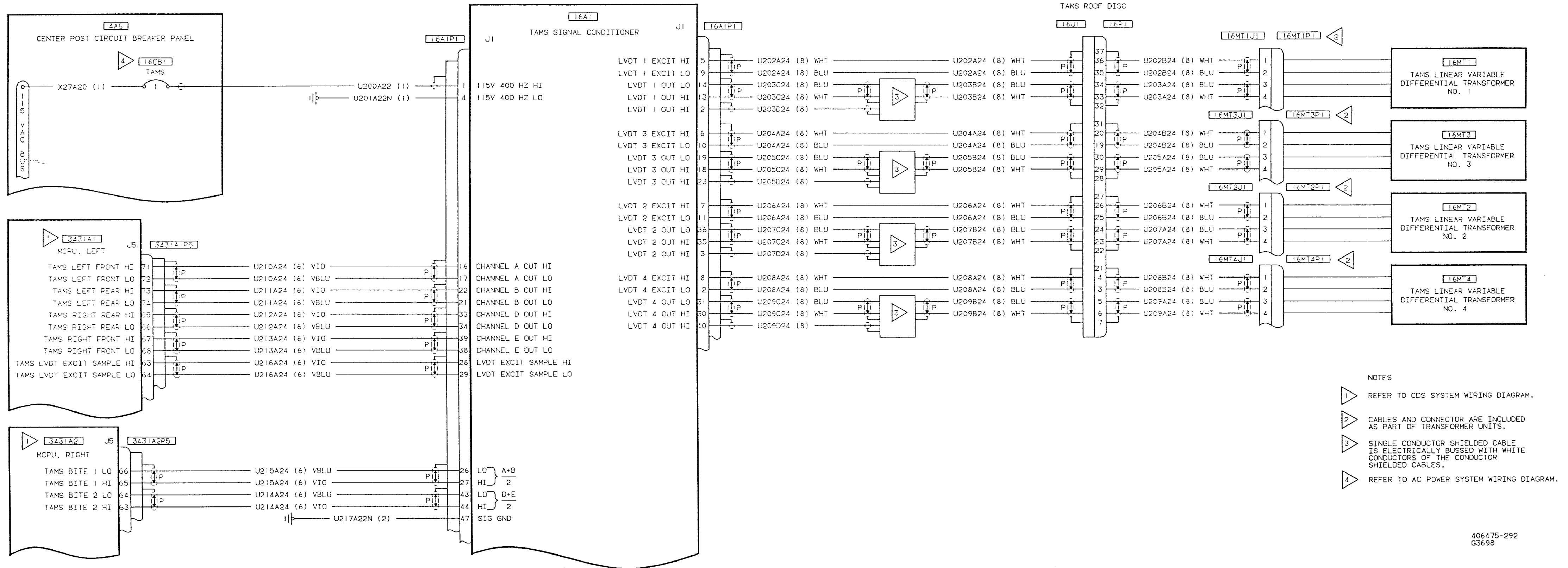
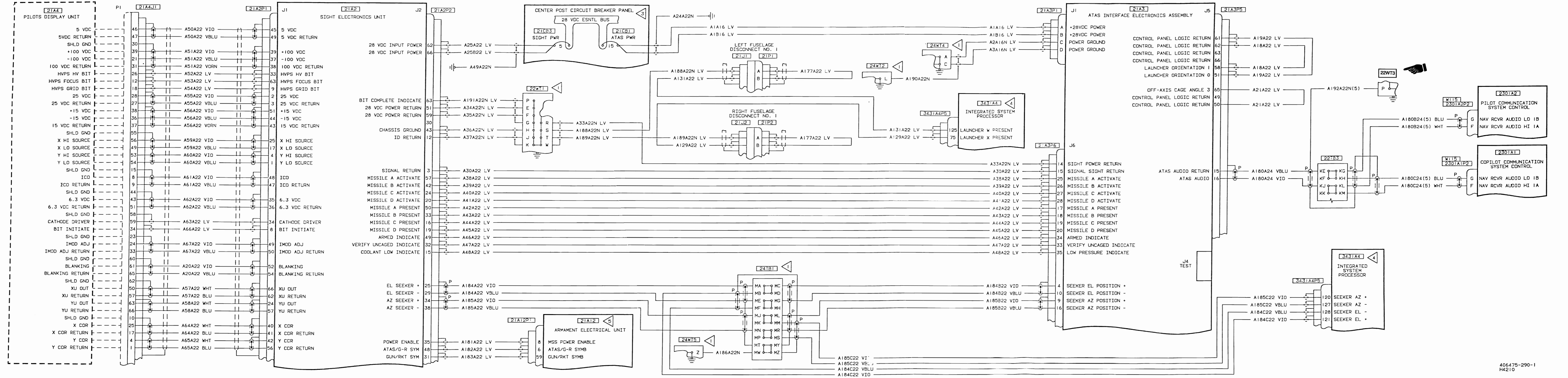

Figure FO-8. Control Display System (CDS) Wiring Diagram (OH-58D) (Sheet 10 of 10)



406475-292
G3698

Figure FO-9. Transmission Attitude Measurement System (TAMS) Wiring Diagram (OH-58D)



406475-290-1
H4210

Figure FO-10. Air-to-Air Stinger (ATAS) Missile System Wiring Diagram (OH-58D) (Sheet 1 of 3)

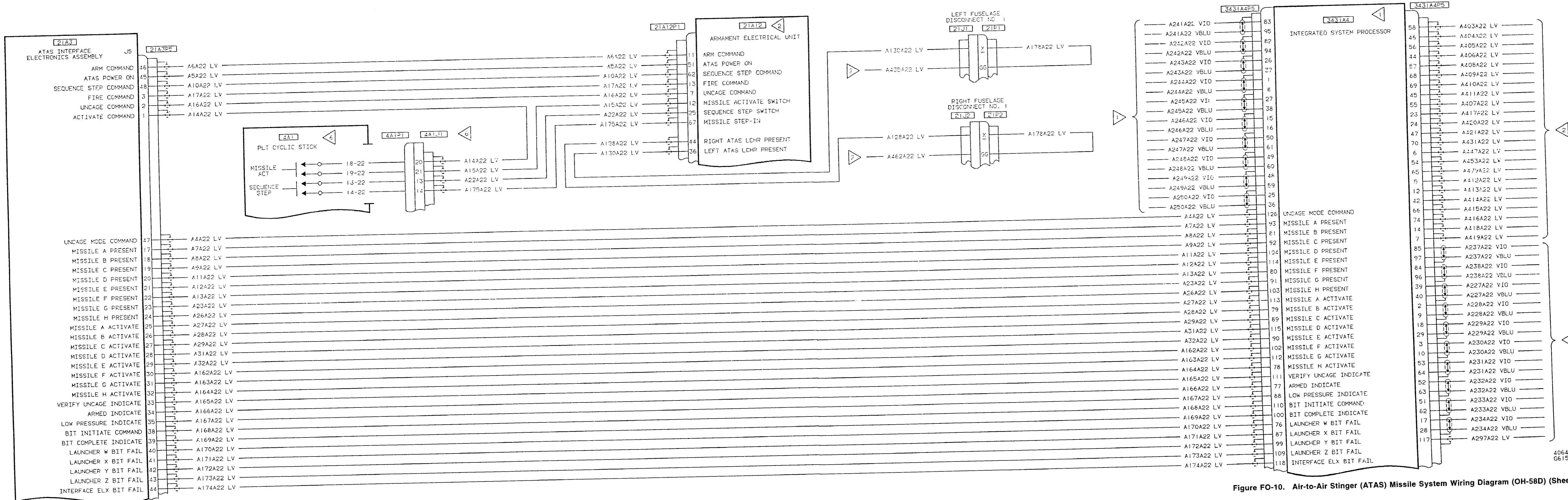
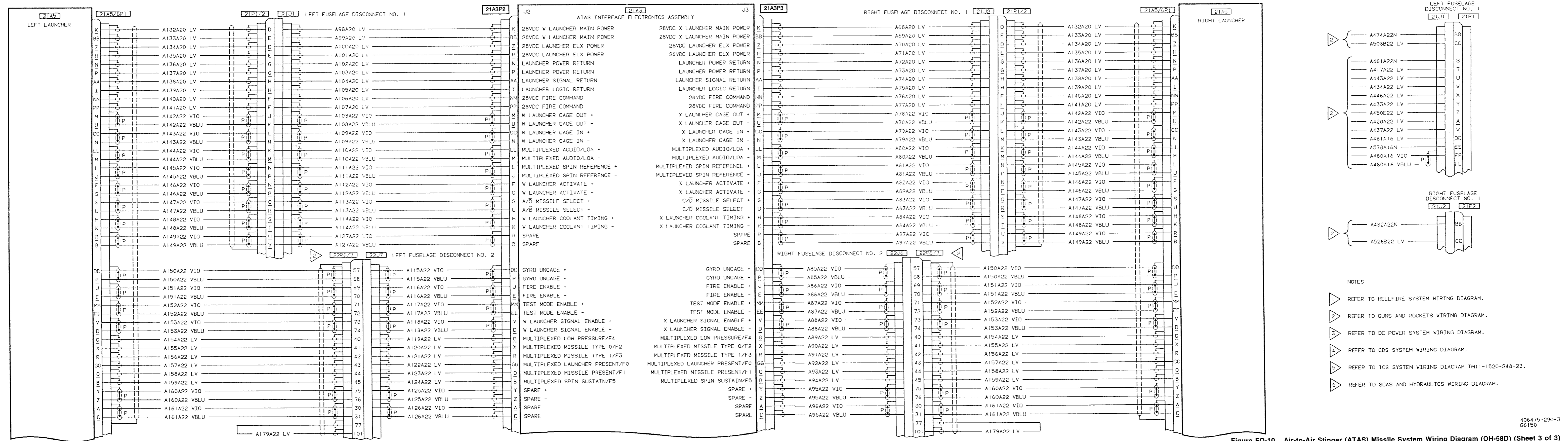

Figure FO-10. Air-to-Air Stinger (ATAS) Missile System Wiring Diagram (OH-58D) (Sheet 2 of 3)

406475-290-2
G6150



- NOTES
- 1 REFER TO HELLFIRE SYSTEM WIRING DIAGRAM.
 - 2 REFER TO GUNS AND ROCKETS WIRING DIAGRAM.
 - 3 REFER TO DC POWER SYSTEM WIRING DIAGRAM.
 - 4 REFER TO CDS SYSTEM WIRING DIAGRAM.
 - 5 REFER TO ICS SYSTEM WIRING DIAGRAM TM11-1520-248-23.
 - 6 REFER TO SCAS AND HYDRAULICS WIRING DIAGRAM.

Figure FO-10. Air-to-Air Stinger (ATAS) Missile System Wiring Diagram (OH-58D) (Sheet 3 of 3)

406475-290-3
G6150

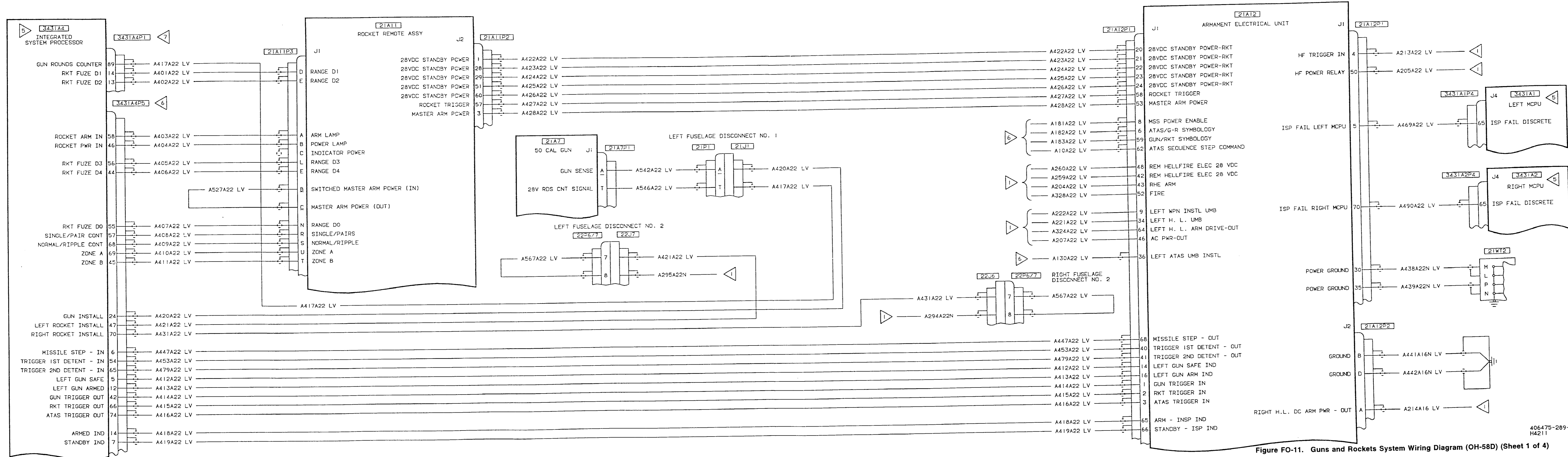

Figure FO-11. Guns and Rockets System Wiring Diagram (OH-58D) (Sheet 1 of 4)

406475-289-1
H4211

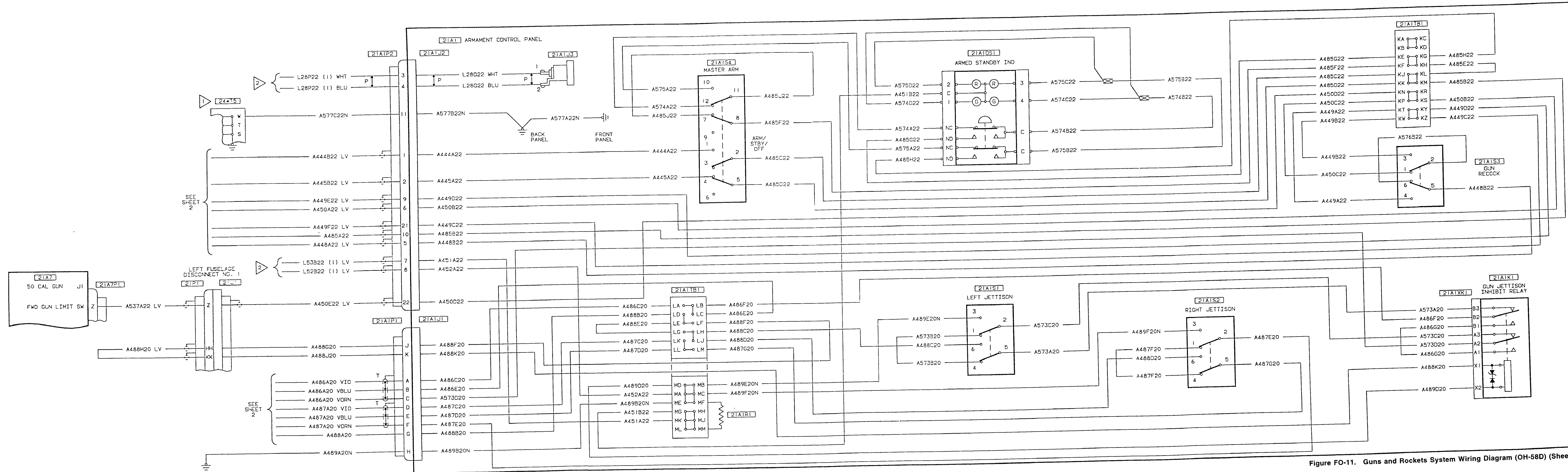

Figure FO-11. Guns and Rockets System Wiring Diagram (OH-58D) (Sheet 3 of 4)

406475-289-3 H4211

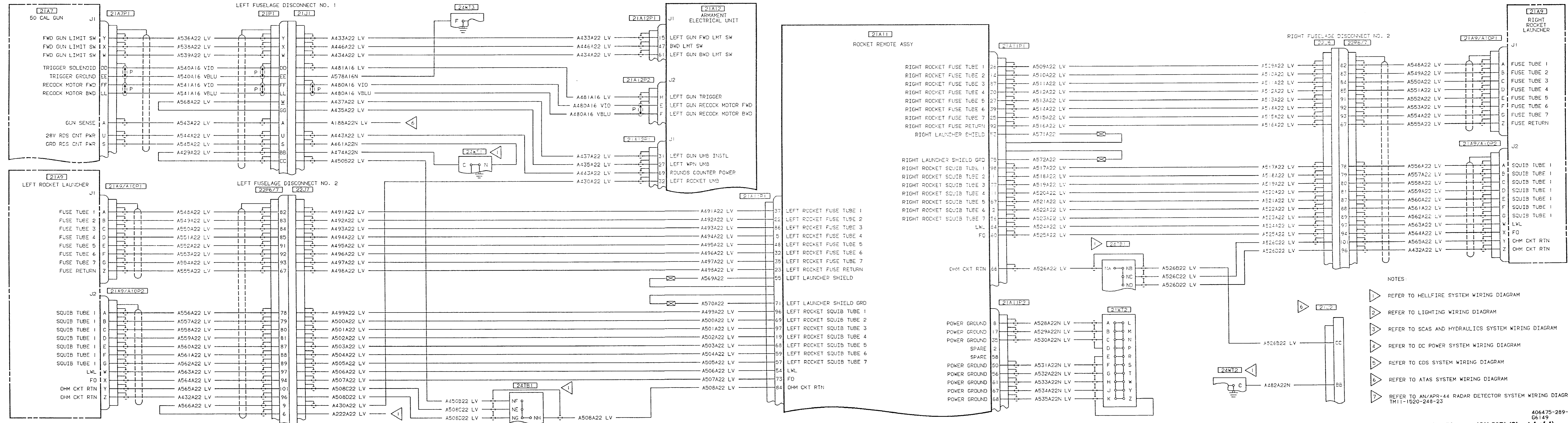

Figure FO-11. Guns and Rockets System Wiring Diagram (OH-58D) (Sheet 4 of 4)

406475-289-4
G6149

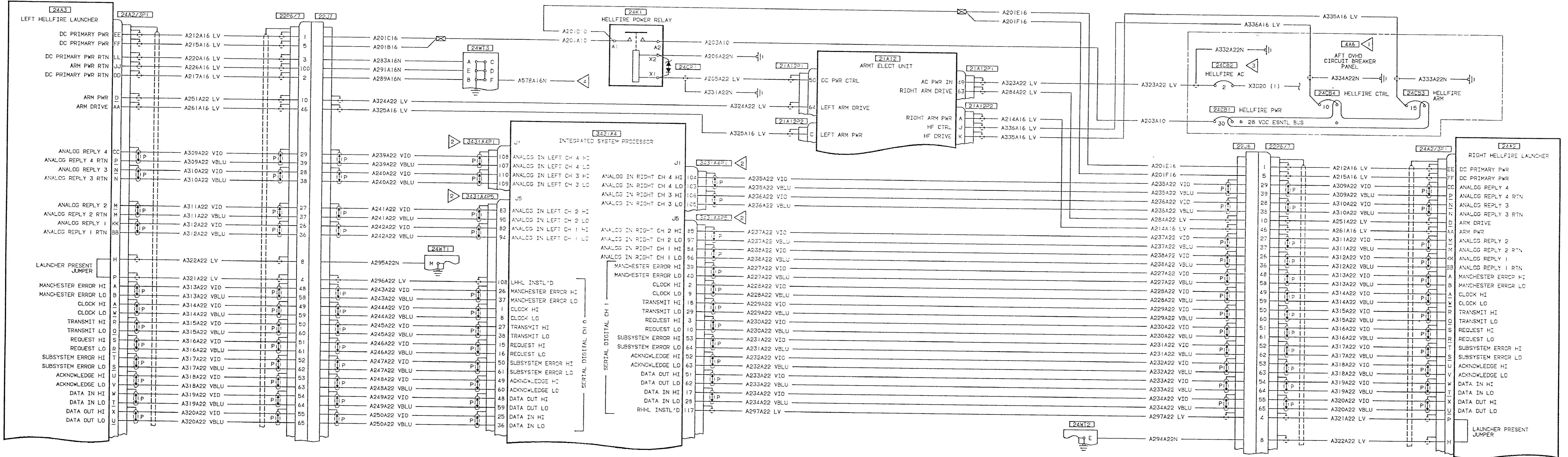
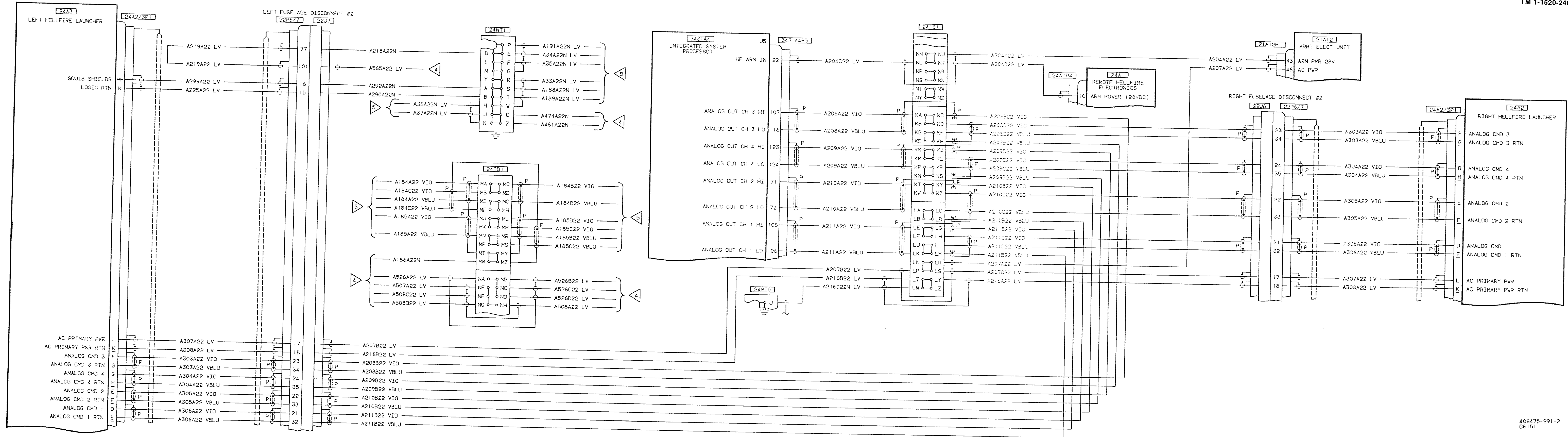

Figure FO-12. HELLFIRE Missile System (HMS) Wiring Diagram (OH-58D) (Sheet 1 of 3)

406475-291-1
G6151



406475-291-2
G6151

Figure FO-12. HELLFIRE Missile System (HMS) Wiring Diagram (OH-58D) (Sheet 2 of 3)

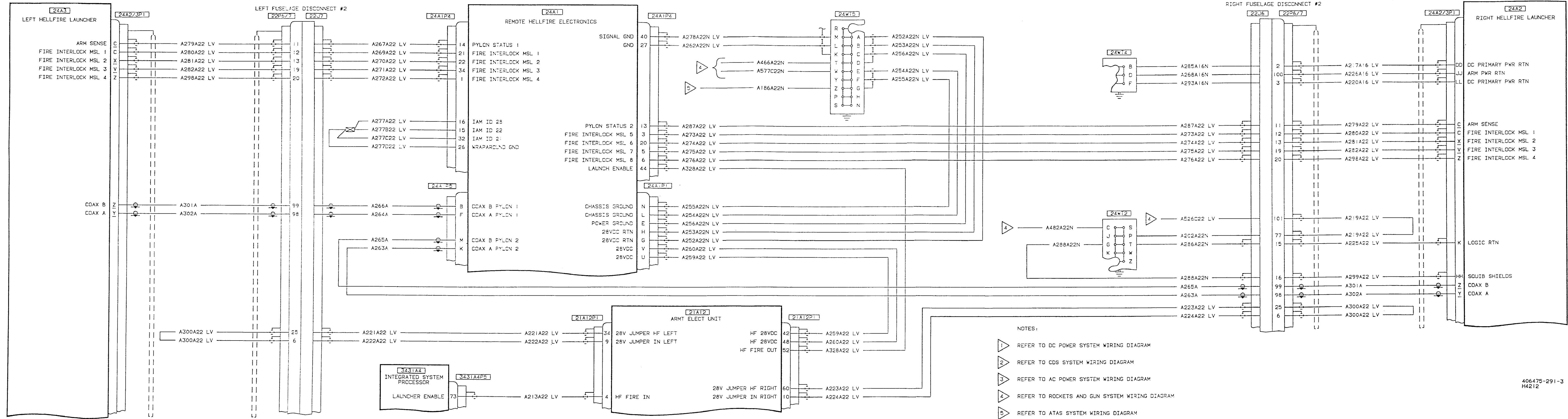
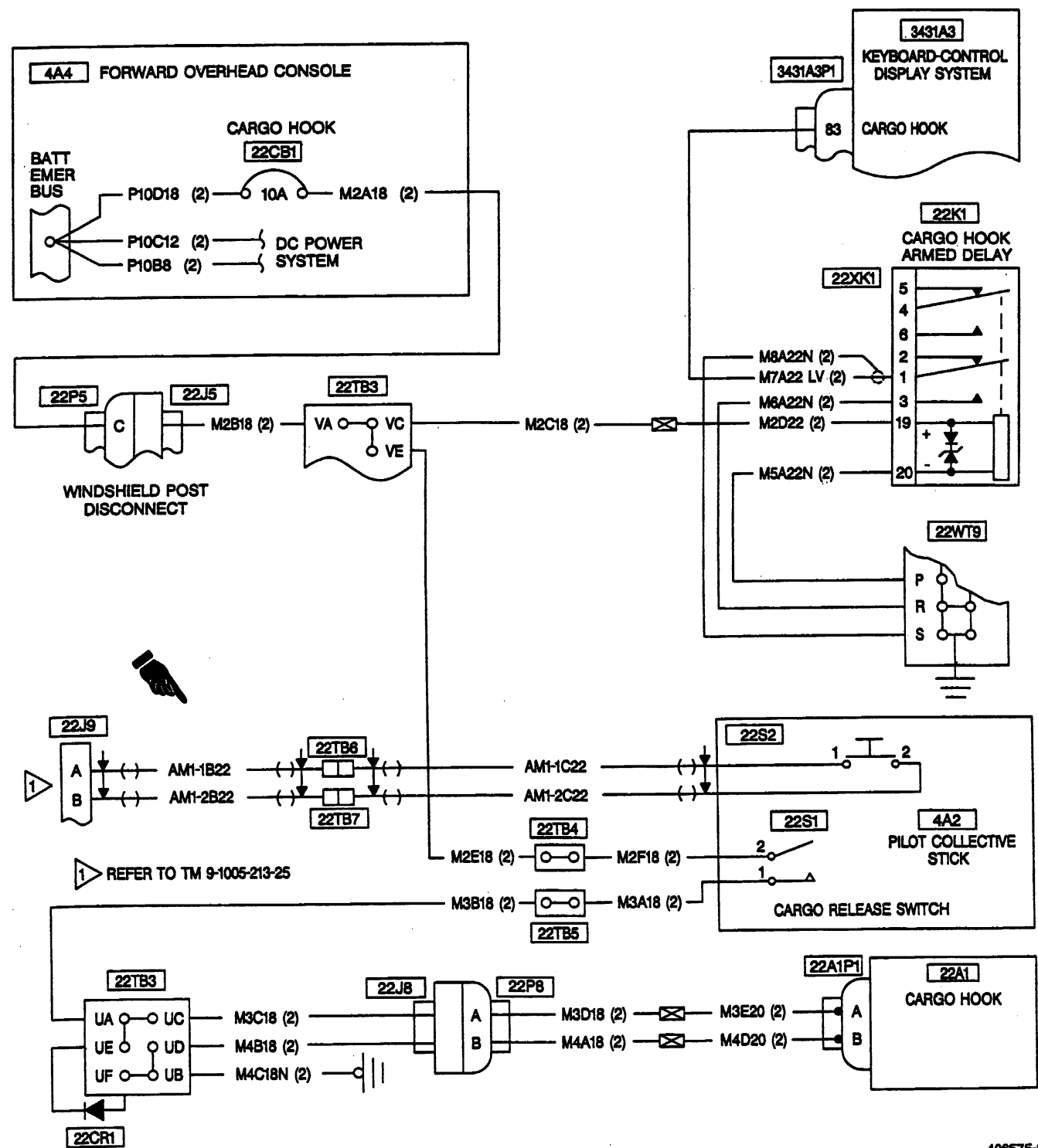
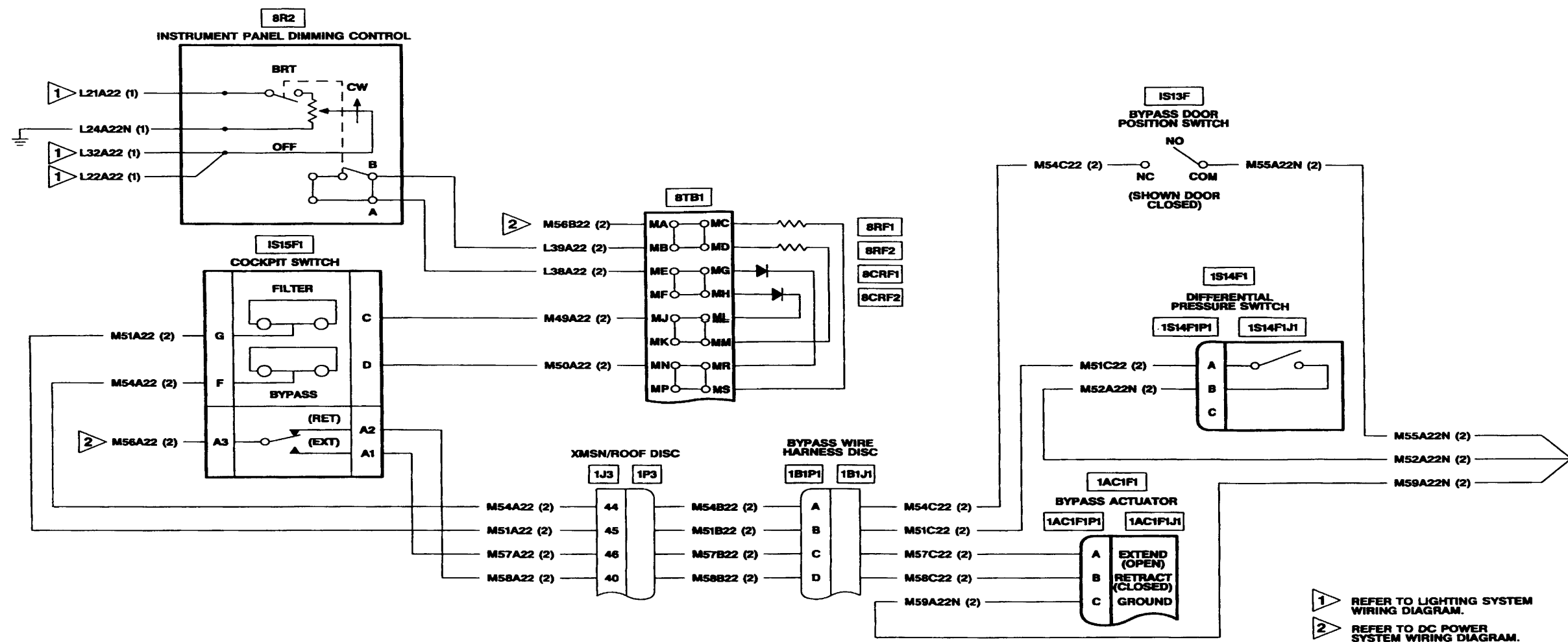

Figure FO-12. HELLFIRE Missile System (HMS) Wiring Diagram (OH-58D) (Sheet 3 of 3)



406575-21
J3423

Figure FO-13. Cargo Hook System Wiring Diagram (OH-58D)



406475-544-9
J3238

Figure FO-13.1. Engine Barrier Filter (EBF) System Wiring Diagram (OH-58D)

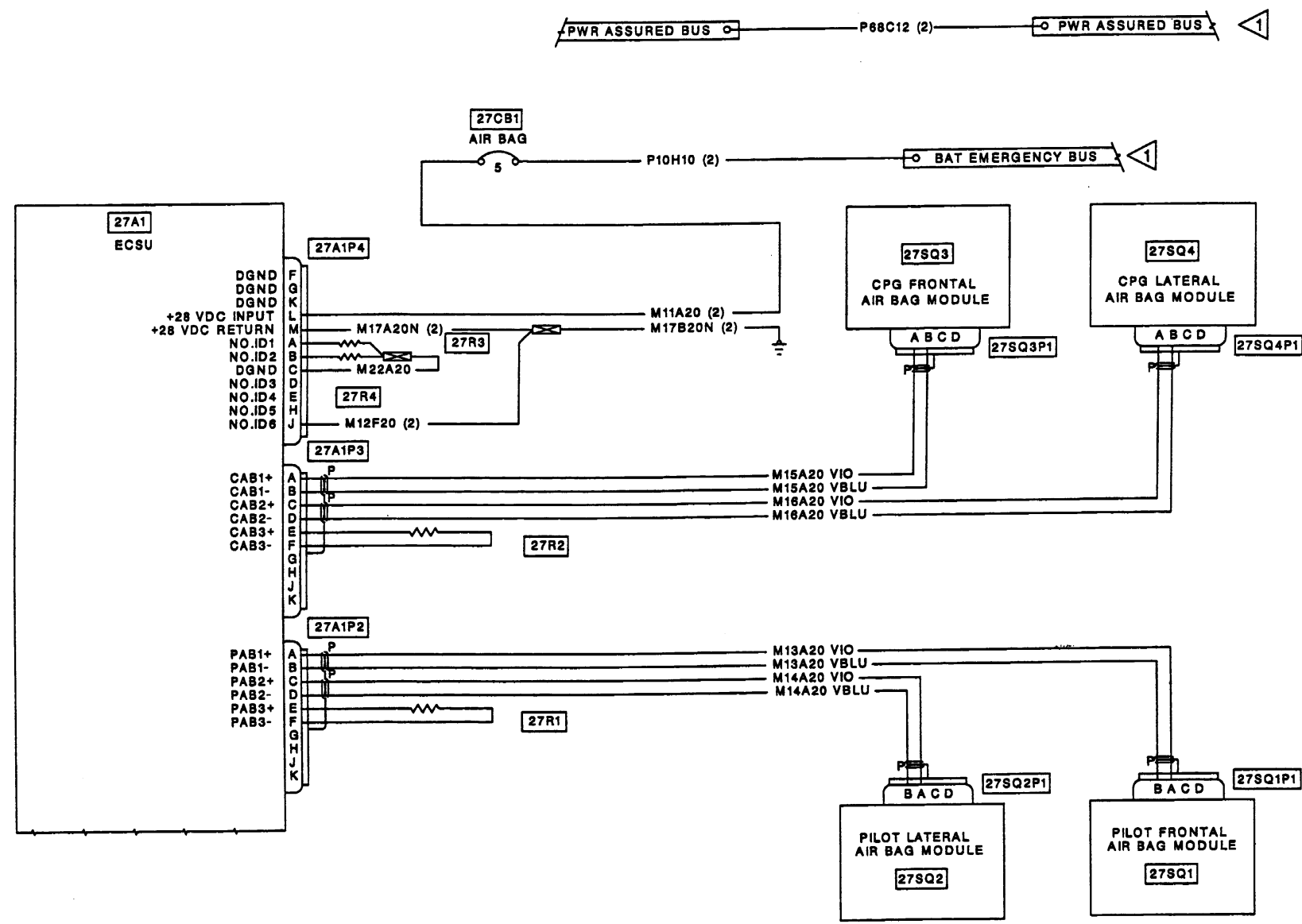

NOTES:
 1 REFER TO DC POWER SYSTEM WIRING DIAGRAM.

406530-79
 J3422

Figure FO-13.2 Cockpit Airbag System (CABS) Wiring Diagram (OH-58D)

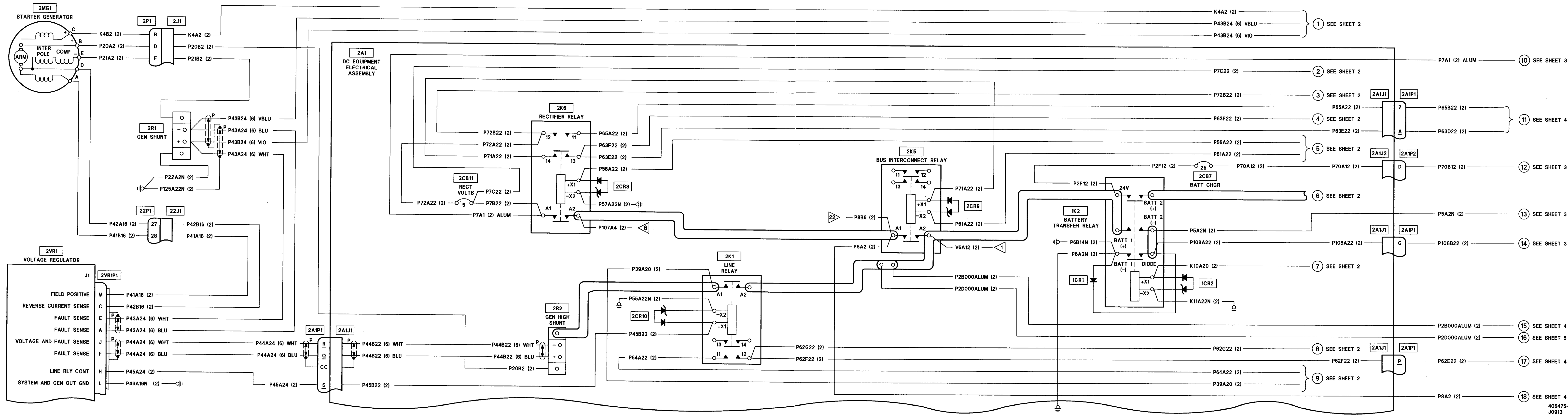

Figure FO-14. DC Power System Wiring Diagram (OH-58D(R)) (Sheet 1 of 6)

406475-524-1
J0913

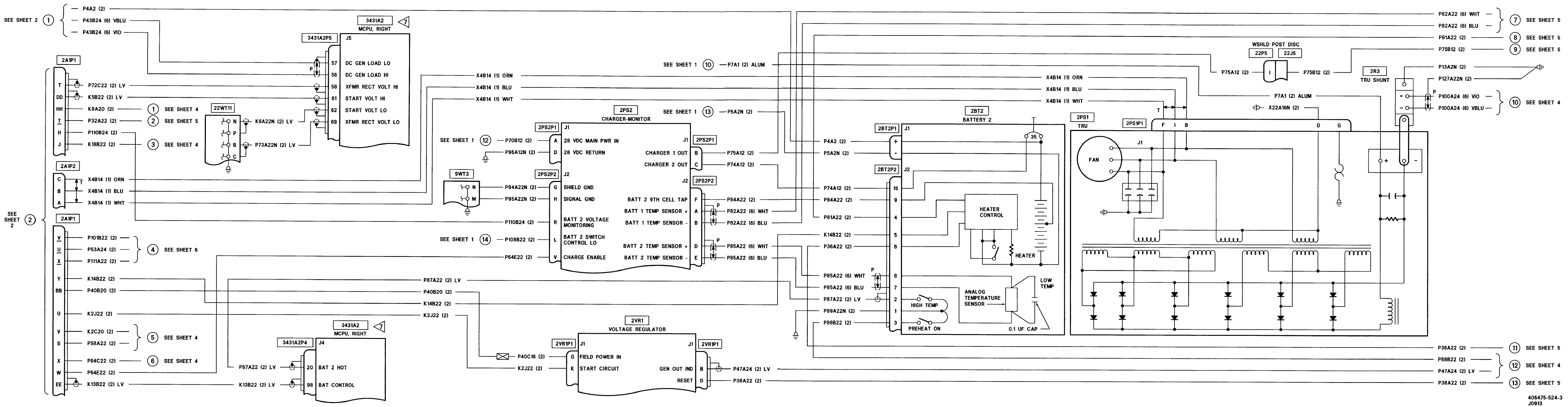

Figure FO-14. DC Power System Wiring Diagram (OH-58D(R)) (Sheet 3 of 6)

406475-524-3
J0913

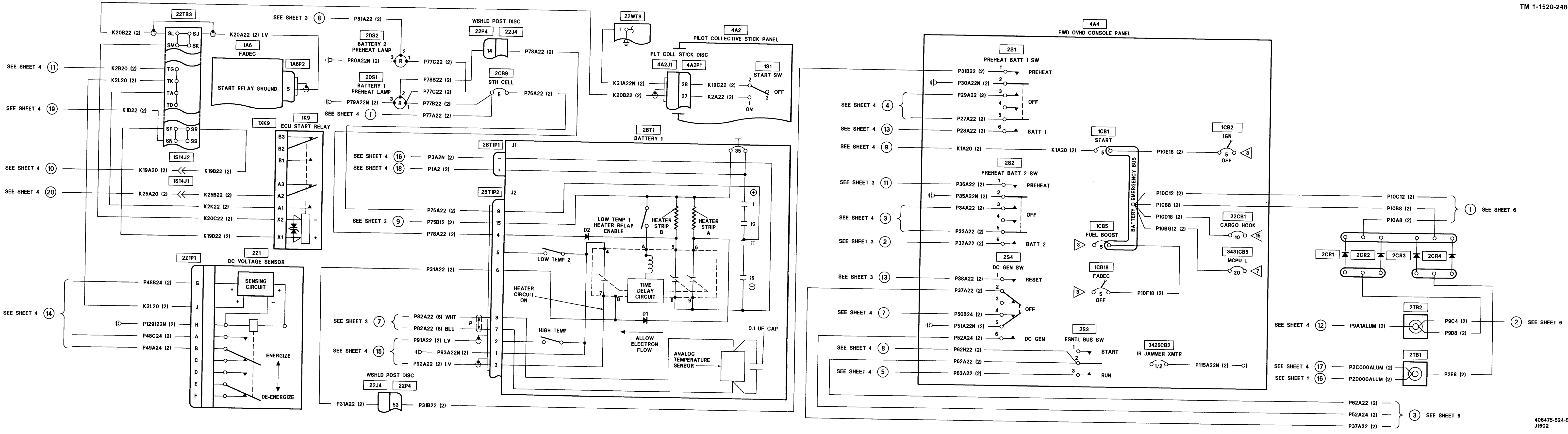
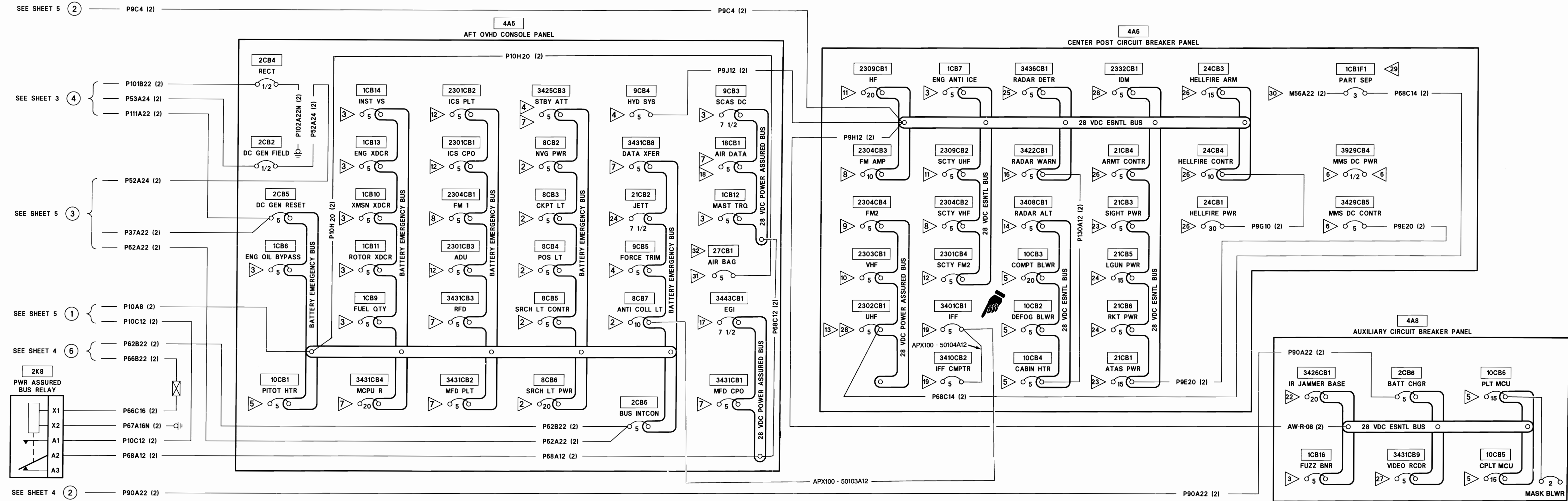

Figure FO-14. DC Power System Wiring Diagram (OH-58D(R)) (Sheet 5 of 6)



- NOTES**
- 1 REFER TO AC POWER SYSTEM WIRING DIAGRAM.
 - 2 REFER TO LIGHTING SYSTEM WIRING DIAGRAM.
 - 3 REFER TO POWERPLANT AND TRANSMISSION SYSTEM WIRING DIAGRAM.
 - 4 REFER TO SCAS, HYDRAULIC, AND STANDBY ATTITUDE GYRO SYSTEM WIRING DIAGRAM.
 - 5 REFER TO ENVIRONMENTAL SYSTEM WIRING DIAGRAM.
 - 6 REFER TO MAST MOUNTED SIGHT (MMS) SYSTEM WIRING DIAGRAM.
 - 7 REFER TO CONTROL DISPLAY SYSTEM (CDS) WIRING DIAGRAM.
 - 8 REFER TO NO. 1 VHF-FM WIRING DIAGRAM TM 11-1520-248-23.
 - 9 REFER TO NO. 2 VHF-FM WIRING DIAGRAM TM 11-1520-248-23.
 - 10 REFER TO VHF-AM WIRING DIAGRAM TM 11-1520-248-23.
 - 11 REFER TO HF WIRING DIAGRAM TM 11-1520-248-23.
 - 12 REFER TO ICS WIRING DIAGRAM TM 11-1520-248-23.
 - 13 REFER TO UHF WIRING DIAGRAM TM 11-1520-248-23.
 - 14 REFER TO RADAR ALTIMETER WIRING DIAGRAM TM 11-1520-248-23.
 - 15 REFER TO CARGO HOOK WIRING DIAGRAM.
 - 16 REFER TO RADAR WARNING WIRING DIAGRAM TM 11-1520-248-23.
 - 17 REFER TO EGI WIRING DIAGRAM TM 11-1520-248-23.
 - 18 REFER TO AIR DATA SYSTEM (ADS) WIRING DIAGRAM.
 - 19 REFER TO IFF WIRING DIAGRAM TM 11-1520-248-23.
 - 20 SEE VIEW A FOR IDENTIFICATION OF SWITCH TERMINALS.
 - 21 NUMBERED CIRCLE ON RIGHT SIDE OF SHEET SIGNIFIES "SEE SHEET" AND FIND SAME NUMBER ON LEFT SIDE OF SHEET WITH MATCHING WIRE NUMBER(S).
 - 22 REFER TO AN/ALQ-144 WIRING DIAGRAM TM 11-1520-248-23.
 - 23 REFER TO AIR-TO-AIR STINGER (ATAS) SYSTEM WIRING DIAGRAM.
 - 24 REFER TO GUNS AND ROCKETS SYSTEM WIRING DIAGRAM.
 - 25 REFER TO AN/APR-44 WIRING DIAGRAM TM 11-1520-248-23.
 - 26 REFER TO HELLFIRE MISSILE SYSTEM (HMS) WIRING DIAGRAM.
 - 27 REFER TO VIDEO TAPE RECORDER WIRING DIAGRAM TM 11-1520-248-23.
 - 28 REFER TO IDM WIRING DIAGRAM TM 11-1520-248-23.
 - 29 AFTER COMPLIANCE WITH ENGINE BARRIER FILTER MWO 1-1520-248-50-15.
 - 30 REFER TO ENGINE BARRIER FILTER SYSTEM WIRING DIAGRAM.
 - 31 REFER TO COCKPIT AIRBAG SYSTEM (CABS) WIRING DIAGRAM.
 - 32 AFTER COMPLIANCE WITH COCKPIT AIRBAG SYSTEM MWO 1-1520-248-50-14.
 - 33 REFER TO ENVIRONMENTAL SYSTEM WIRING DIAGRAM AND MICROCLIMATE COOLING/NA SK BLOWER SYSTEM SCHEMATIC.

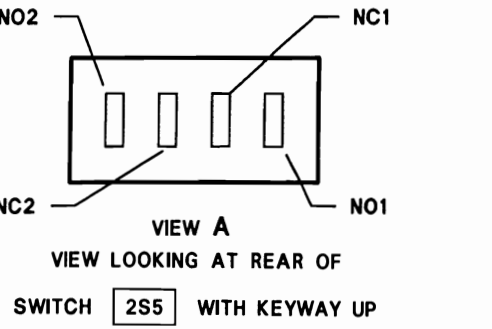
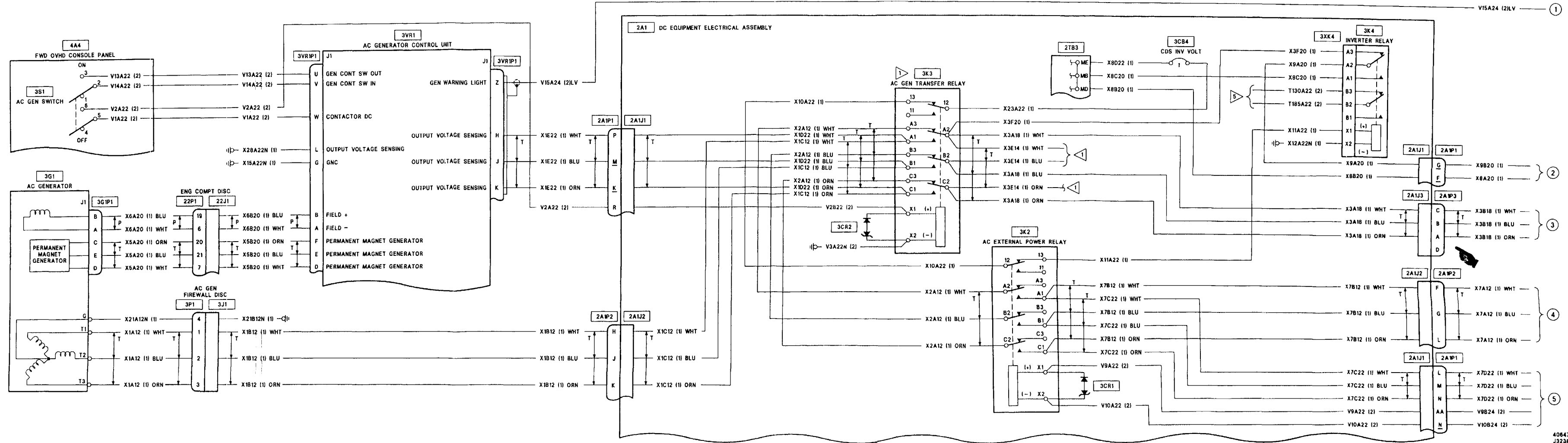

Figure FO-14. DC Power System Wiring Diagram (OH-58D(R)) (Sheet 6 of 6)

406475-544-10 J3238



406475-544-11
J3238

Figure FO-15. AC Power System Wiring Diagram (OH-58D(R) (Sheet 1 of 2)

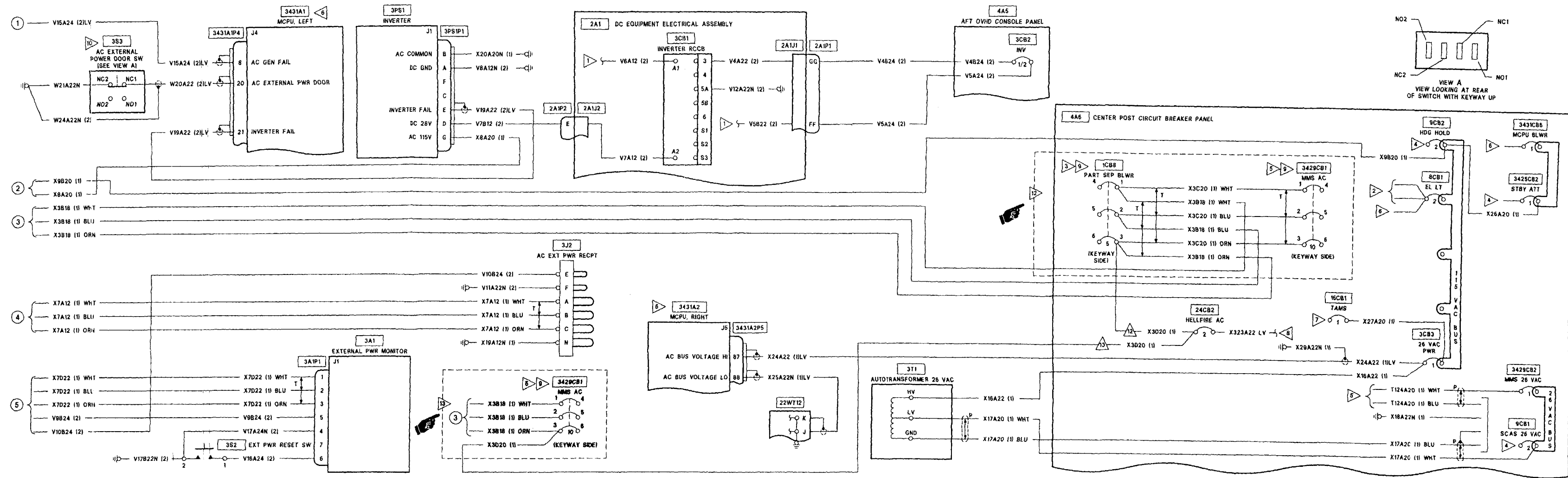

- NOTES**
- 1 REFER TO DC POWER SYSTEM WIRING DIAGRAM.
 - 2 REFER TO LIGHTING SYSTEM WIRING DIAGRAM.
 - 3 REFER TO POWERPLANT AND TRANSMISSION SYSTEM WIRING DIAGRAM.
 - 4 REFER TO SCAS, HYDRAULIC, AND STANDBY ATTITUDE GYRO SYSTEM WIRING DIAGRAM.
 - 5 REFER TO MAST MOUNTED SIGHT (MMS) SYSTEM WIRING DIAGRAM.
 - 6 REFER TO CONTROL DISPLAY SYSTEM (CDS) WIRING DIAGRAM.
 - 7 REFER TO TAMS SYSTEM WIRING DIAGRAM.
 - 8 REFER TO HELLFIRE MISSILE SYSTEM (HMS) WIRING DIAGRAM.
 - 9 VIEW LOOKING AT REAR OF CIRCUIT BREAKER WITH KEYWAY UP. NUMBER WILL READ FROM LEFT TO RIGHT WITH 1, 2, AND 3 ON THE TOP OR KEYWAY SIDE.
 - 10 SWITCH SHOWN WITH DOOR OPEN. SEE VIEW A FOR IDENTIFICATION OF SWITCH TERMINALS.
 - 11 CIRCLED NUMBER SIGNIFIES "GO TO NEXT SHEET" AND FIND SAME CIRCLED NUMBER ON DESTINATION SHEET WITH MATCHING WIRE NUMBER(S).
 - 12 BEFORE COMPLIANCE WITH ENGINE BARRIER FILTER MWO 1-1520-248-50-15.
 - 13 AFTER COMPLIANCE WITH ENGINE BARRIER FILTER MWO 1-1520-248-50-15.

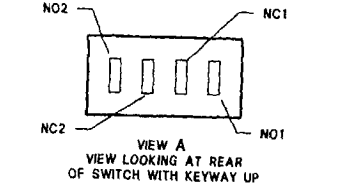
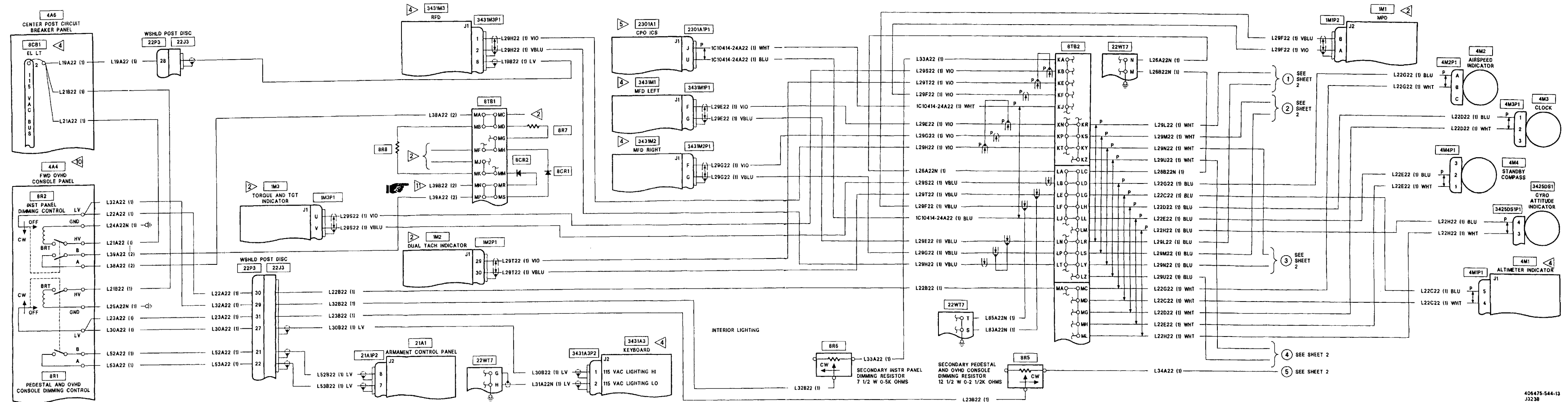
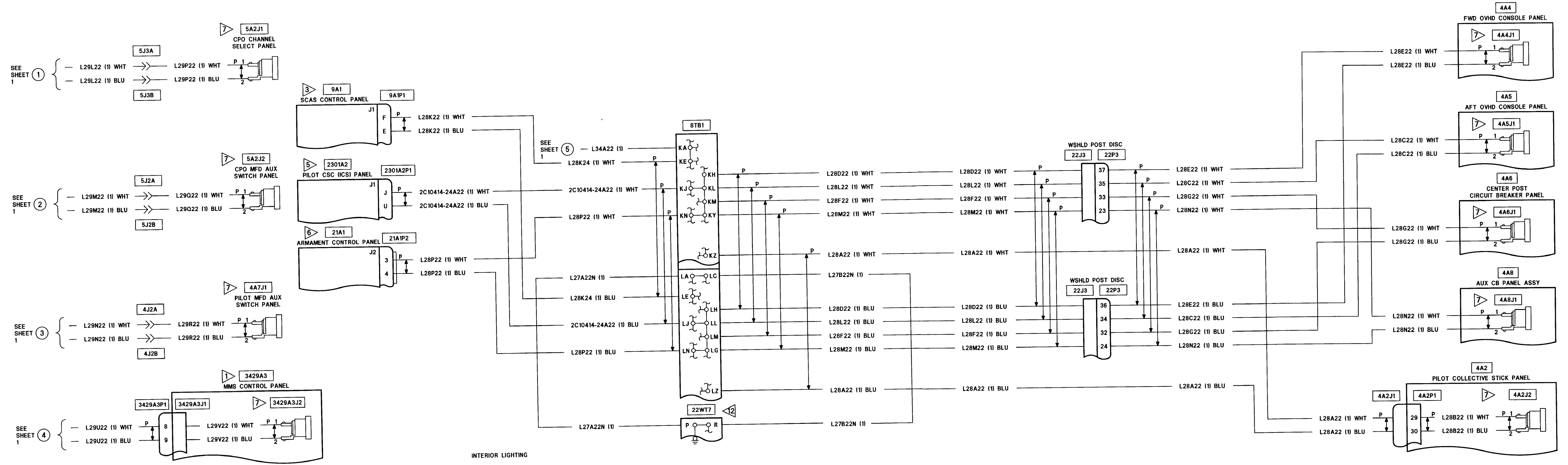

Figure FO-15. AC Power System Wiring Diagram (OH-58D(R)) (Sheet 2 of 2)



406475-544-13
J3238

Figure FO-16. Lighting System Wiring Diagram (OH-58D(R)) (Sheet 1 of 4)



406475-526-2
J0913

Figure FO-16. Lighting System Wiring Diagram (OH-58D(R)) (Sheet 2 of 4)

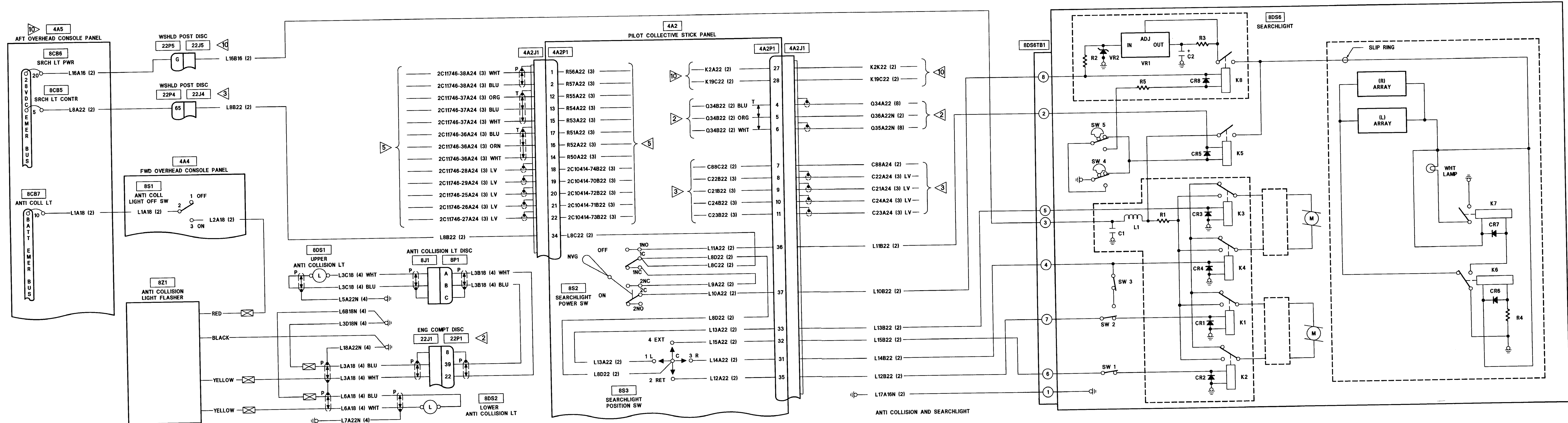

406475-526-3
J0913

Figure FO-16. Lighting System Wiring Diagram (OH-58D(R)) (Sheet 3 of 4)

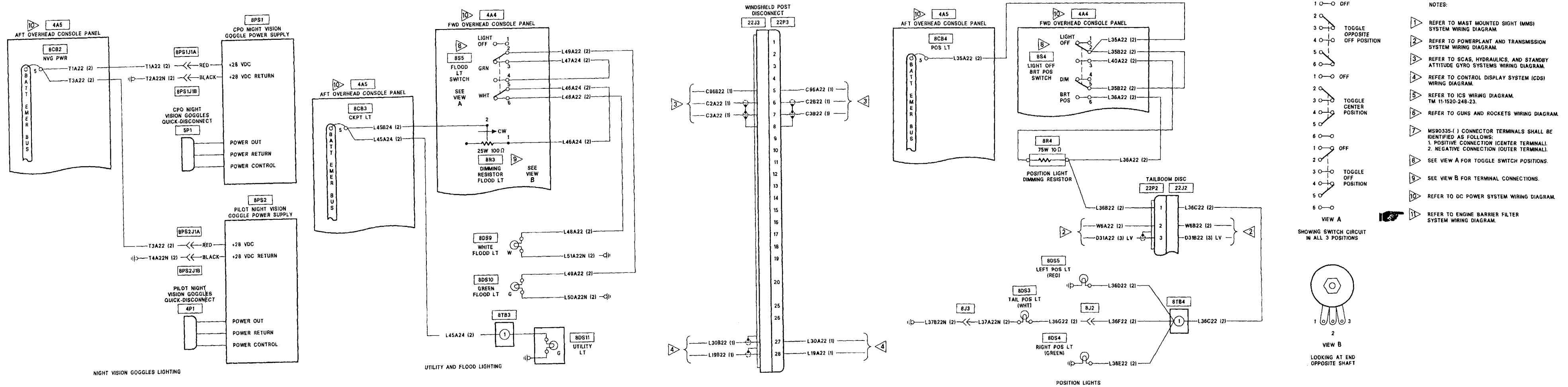

Figure FO-16. Lighting System Wiring Diagram (OH-58D(R)) (Sheet 4 of 4)

406475-544-14
J3238

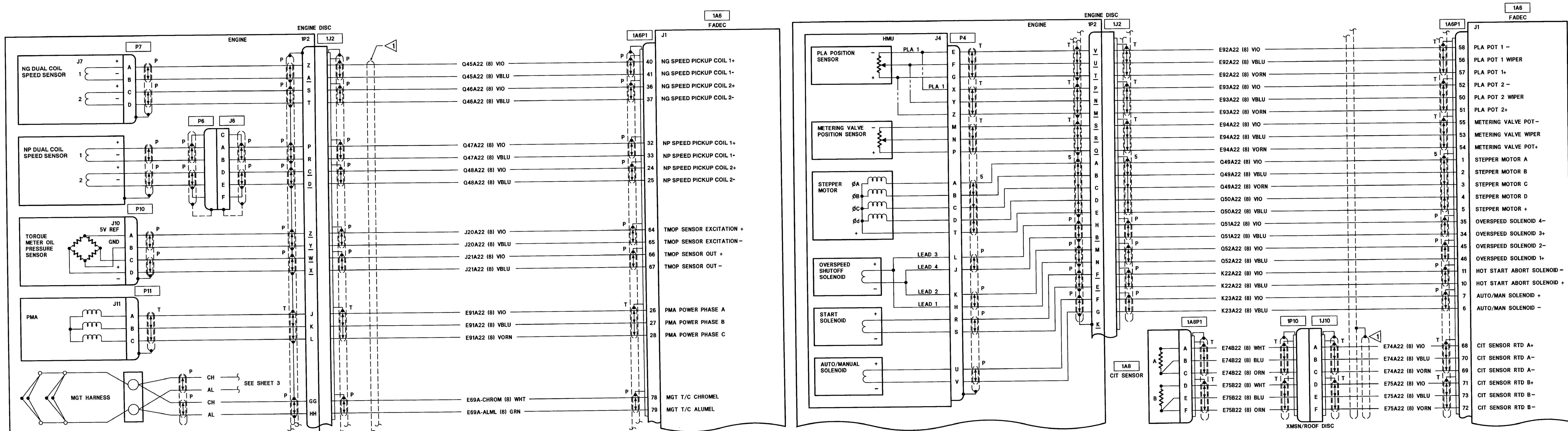

Figure FO-17. Power Plant and Transmission System Wiring Diagram (OH-58D(R)) (Sheet 1 of 9)

406475-527-1
J1602

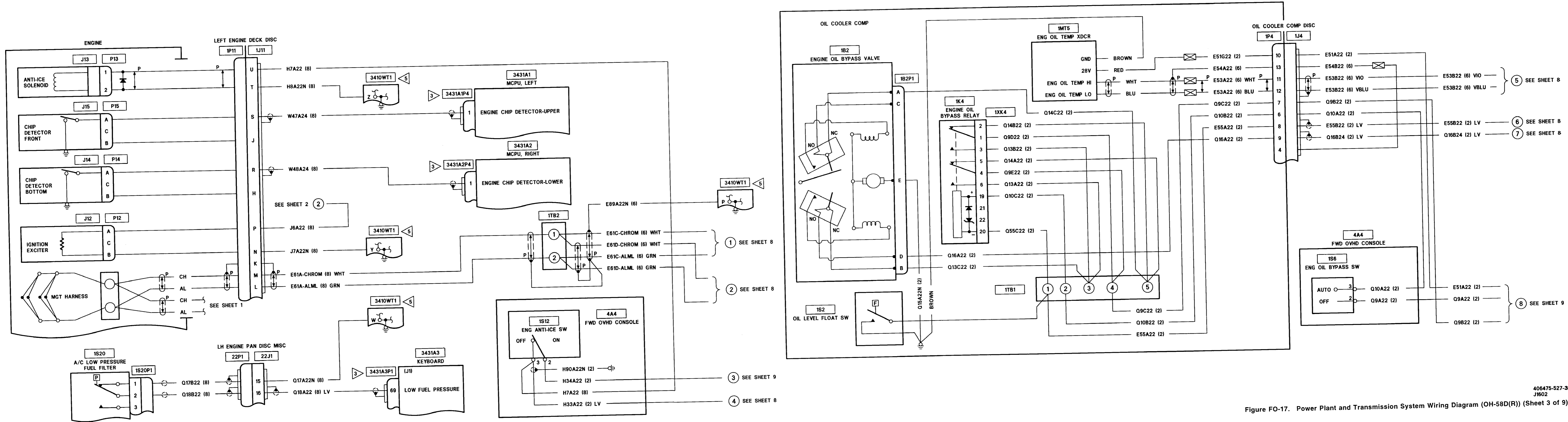

Figure FO-17. Power Plant and Transmission System Wiring Diagram (OH-58D(R)) (Sheet 3 of 9)

406475-527-3
J1602

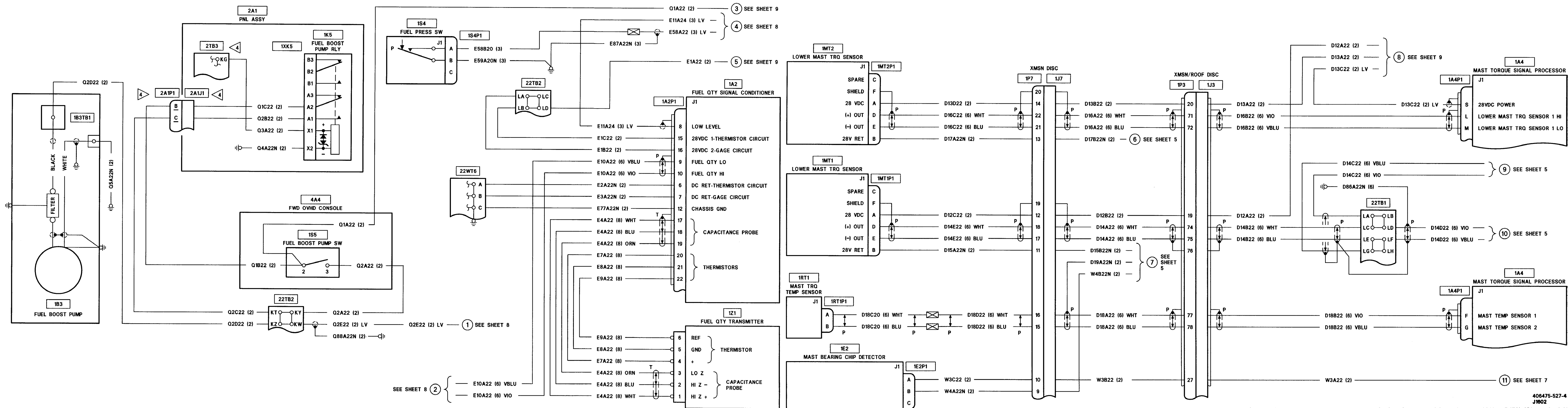

Figure FO-17. Power Plant and Transmission System Wiring Diagram (OH-58D(R)) (Sheet 4 of 9)

406475-527-4
J1802

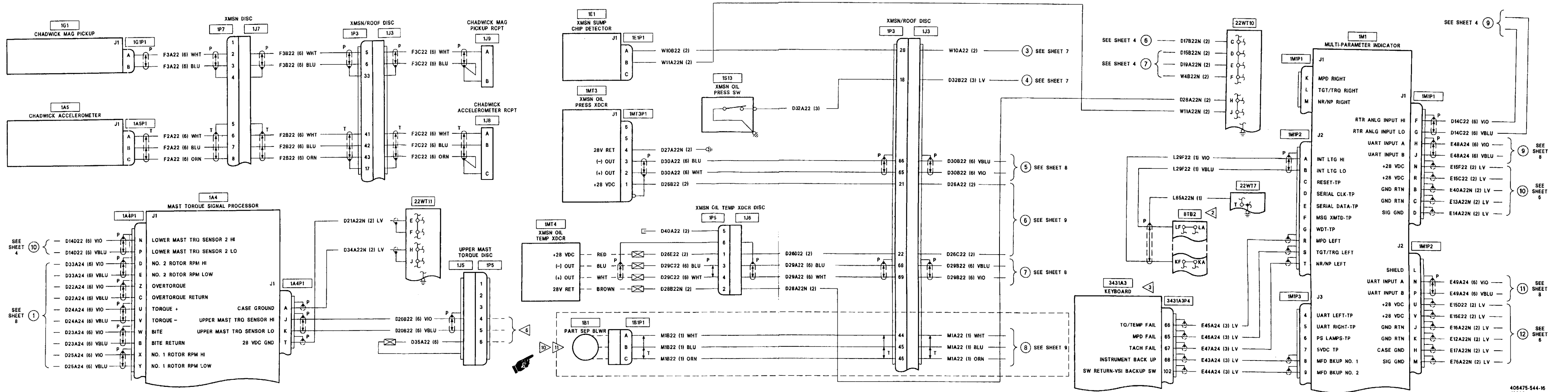

Figure FO-17. Power Plant and Transmission System Wiring Diagram (OH-58D(R)) (Sheet 5 of 9)

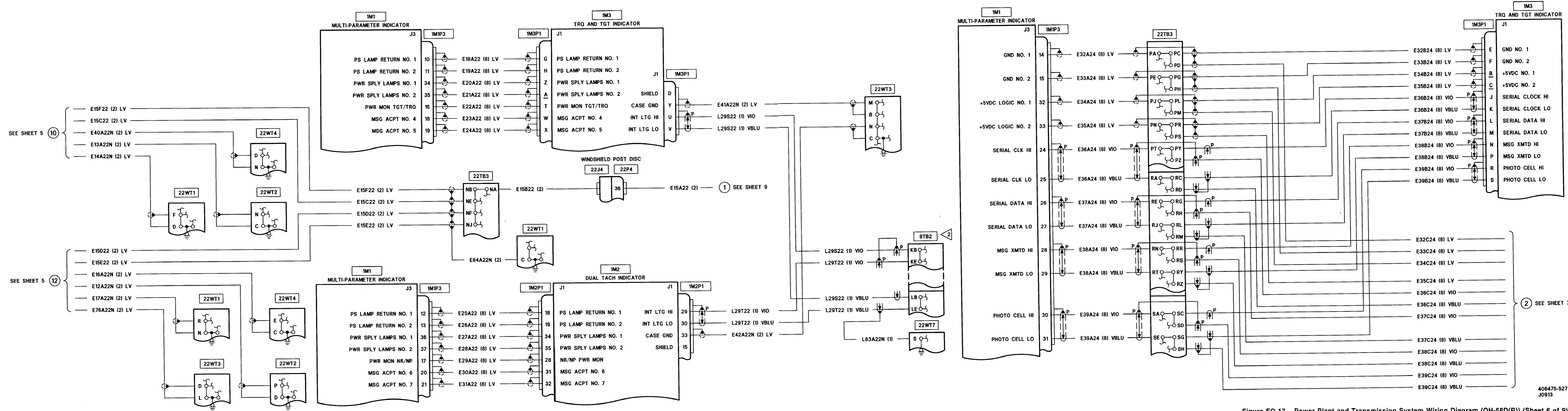

Figure FO-17. Power Plant and Transmission System Wiring Diagram (OH-58D(R)) (Sheet 6 of 9)

406475-527-6
J0913

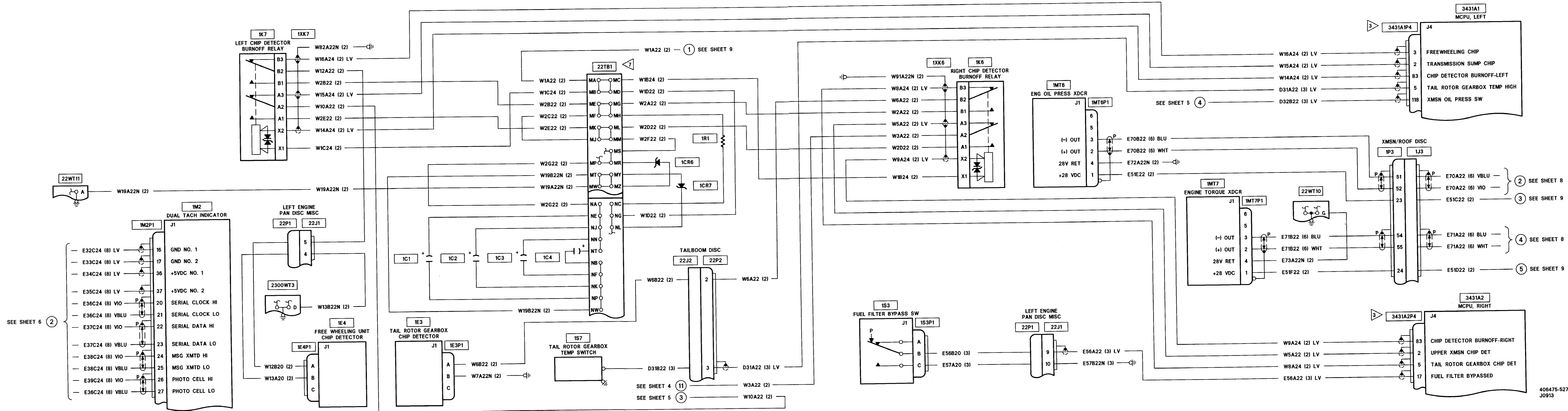
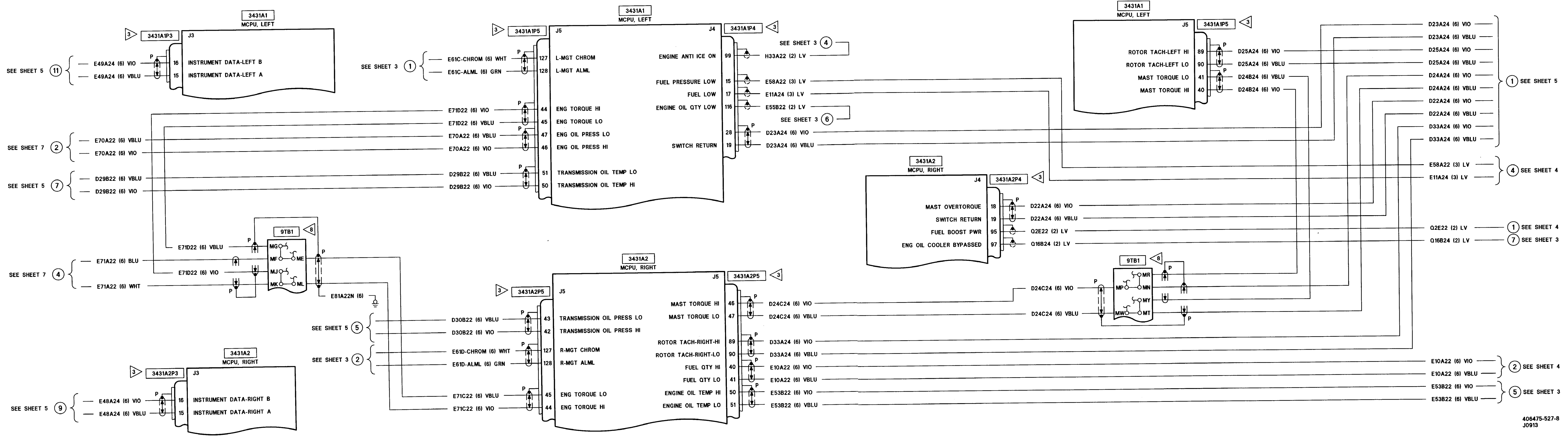

Figure FO-17. Power Plant and Transmission System Wiring Diagram (OH-58D(R)) (Sheet 7 of 9)

406475-527-7
J0913



406475-527-8
J0913

Figure FO-17. Power Plant and Transmission System Wiring Diagram (OH-58D(R)) (Sheet 8 of 9)

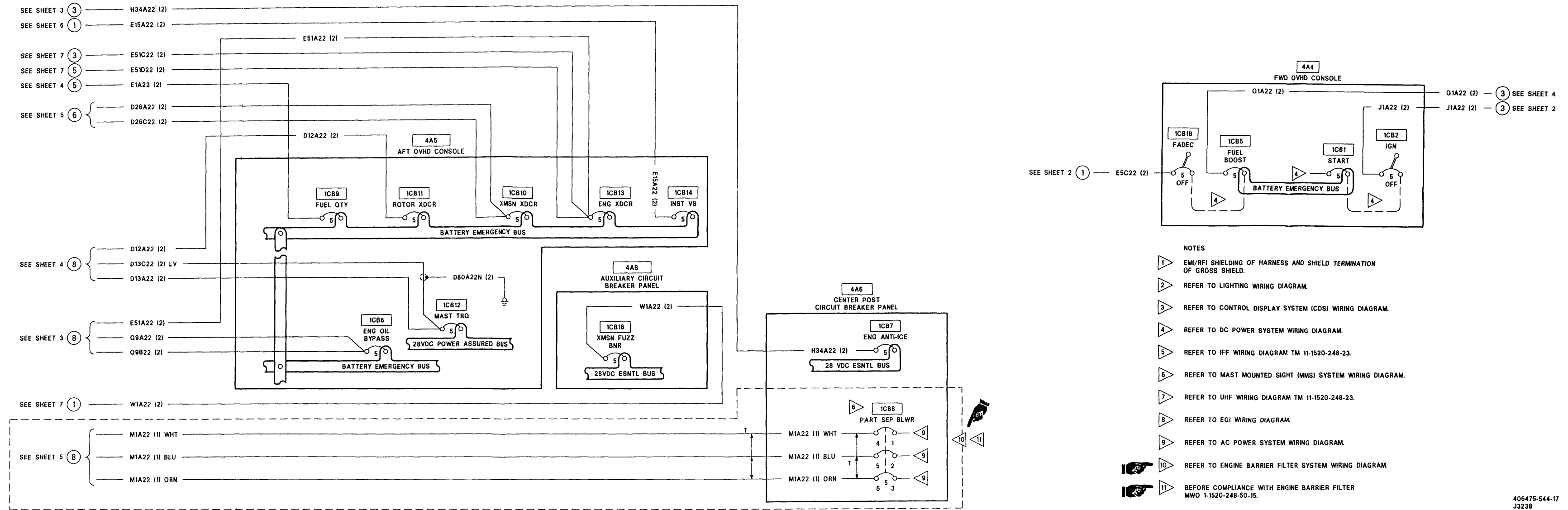

Figure FO-17. Power Plant and Transmission System Wiring Diagram (OH-58D(R)) (Sheet 9 of 9)

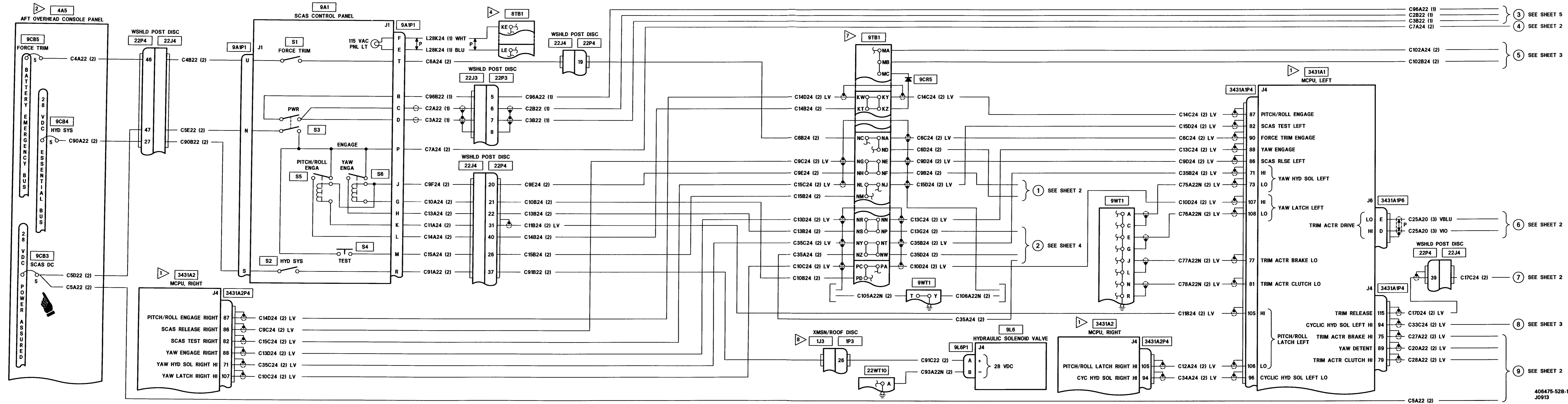
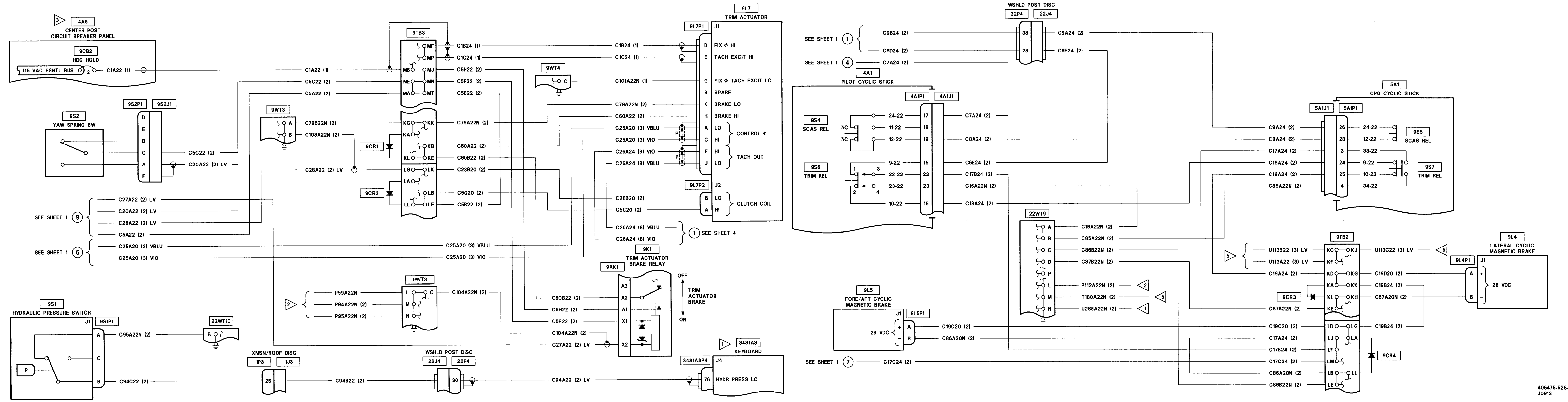

Figure FO-18. SCAS, Hydraulic, and Standby Attitude Gyro System Wiring Diagram (OH-58D(R))
(Sheet 1 of 6)



406475-528-2
J0913

Figure FO-18. SCAS, Hydraulic, and Standby Attitude Gyro System Wiring Diagram (OH-58D(R))
(Sheet 2 of 6)

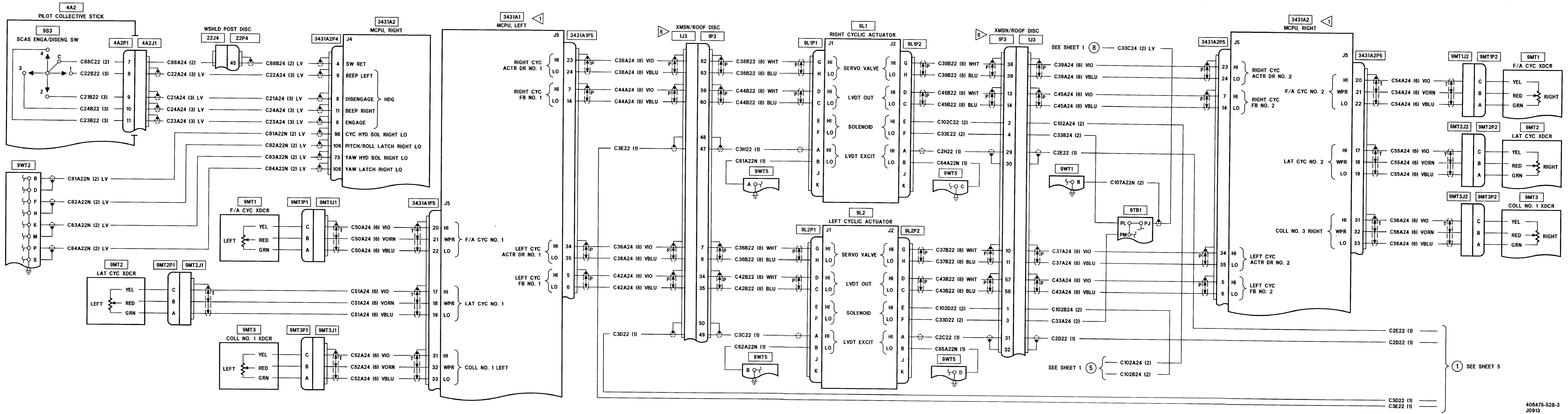

Figure FO-18. SCAS, Hydraulic, and Standby Attitude Gyro System Wiring Diagram (OH-58D(R)) (Sheet 3 of 6)

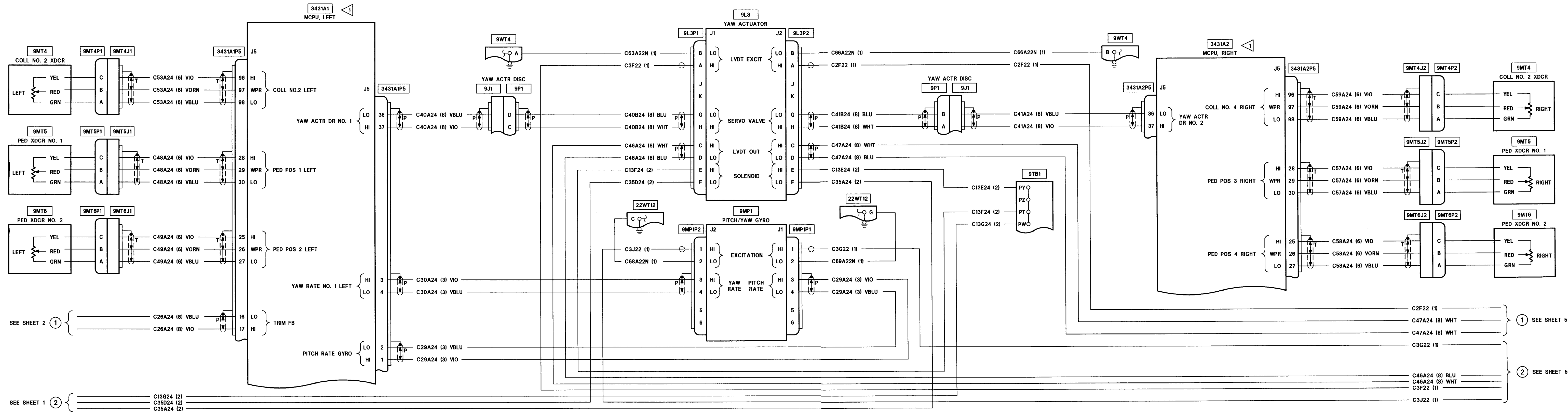

Figure FO-18. SCAS, Hydraulic, and Standby Attitude Gyro System Wiring Diagram (OH-58D(R)) (Sheet 4 of 6)

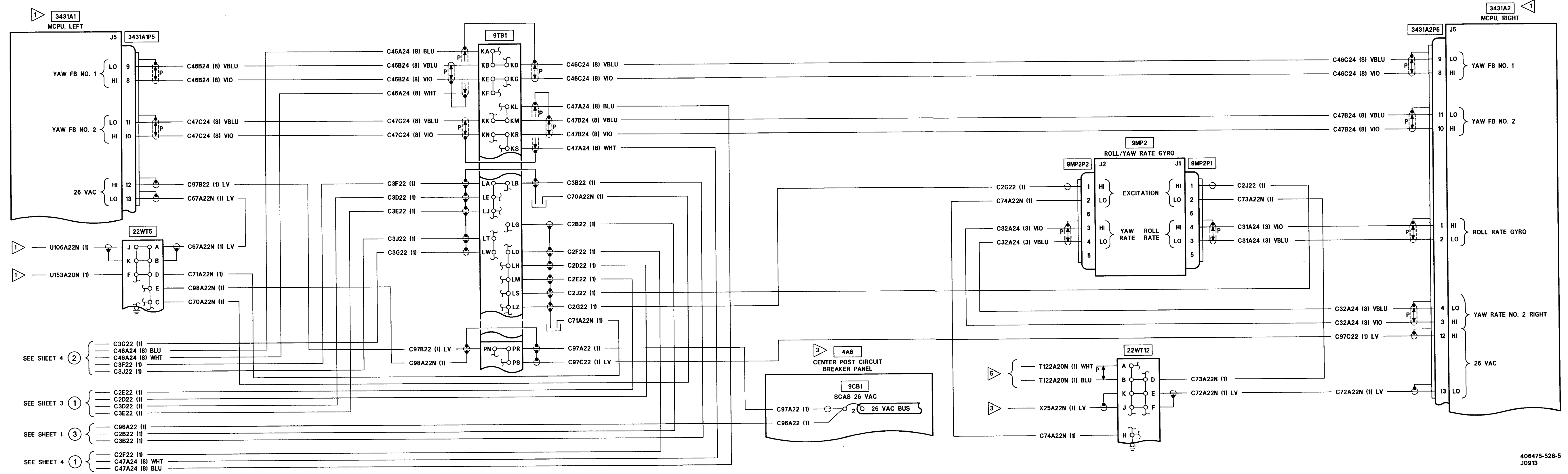
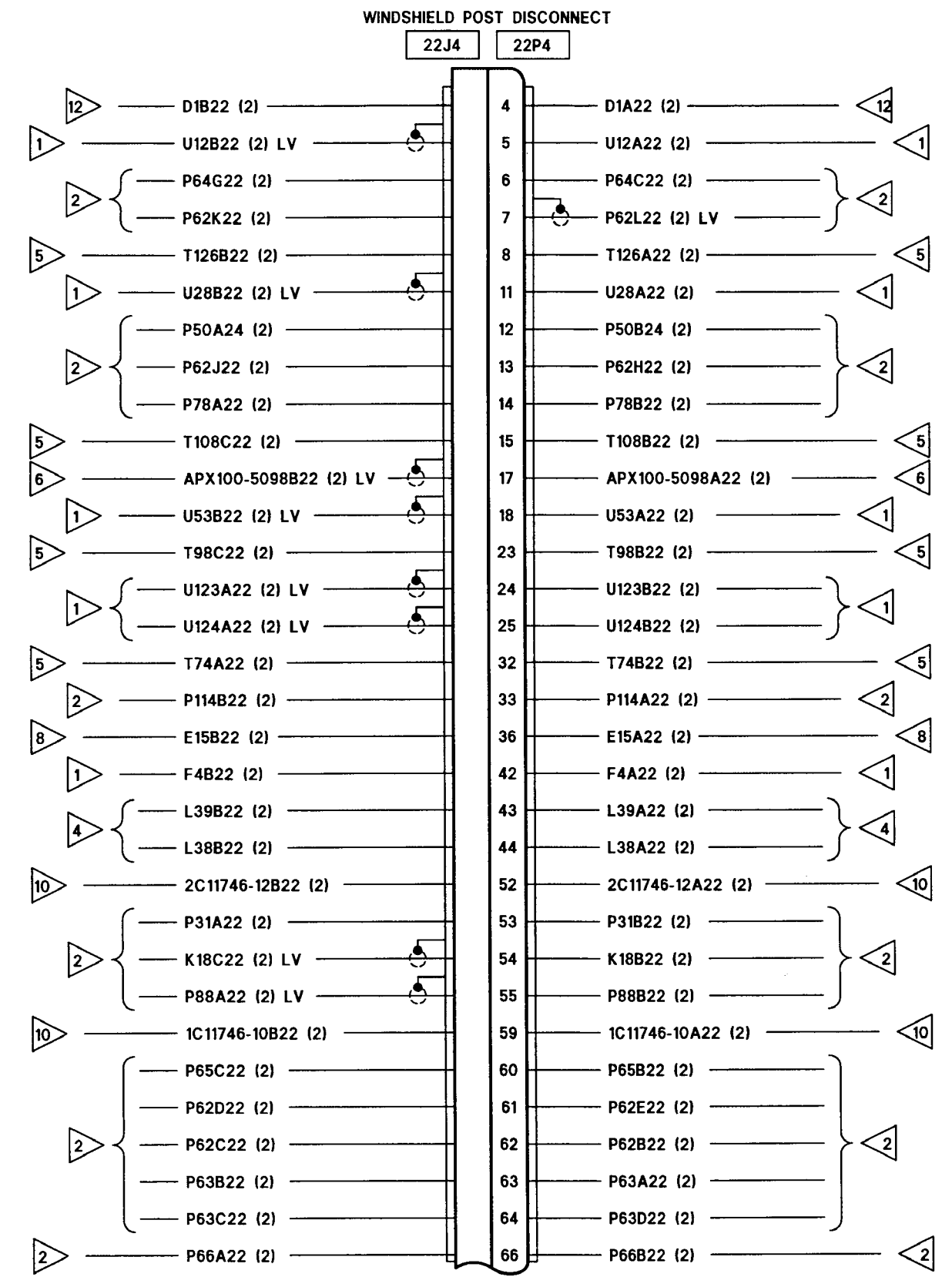
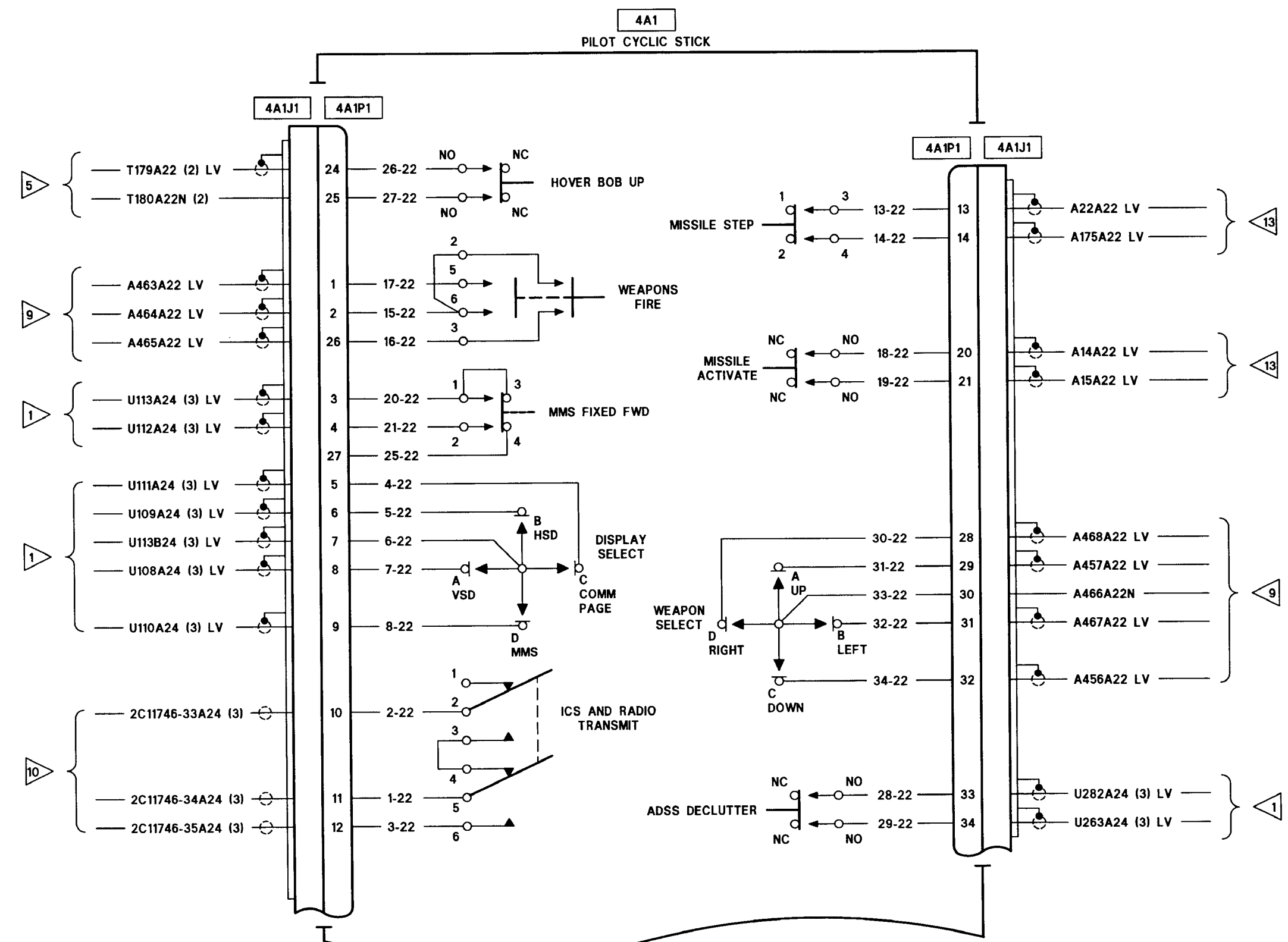

Figure FO-18. SCAS, Hydraulic, and Standby Attitude Gyro System Wiring Diagram (OH-58D(R)) (Sheet 5 of 6)

406475-528-5
J0913



- NOTES**
- 1 REFER TO CONTROL DISPLAY SYSTEM (CDS) WIRING DIAGRAM.
 - 2 REFER TO DC POWER SYSTEM WIRING DIAGRAM.
 - 3 REFER TO AC POWER SYSTEM WIRING DIAGRAM.
 - 4 REFER TO LIGHTING SYSTEM WIRING DIAGRAM.
 - 5 REFER TO MAST MOUNTED SIGHT (MMS) SYSTEM WIRING DIAGRAM.
 - 6 REFER TO IFF WIRING DIAGRAM TM 11-1520-248-23.
 - 7 REFER TO EGI SYSTEM WIRING DIAGRAM TM 11-1520-248-23.
 - 8 REFER TO POWER PLANT AND TRANSMISSION WIRING DIAGRAM.
 - 9 REFER TO GUNS AND ROCKETS SYSTEM WIRING DIAGRAM.
 - 10 REFER TO ICS WIRING DIAGRAM TM 11-1520-248-23.
 - 11. NUMBERED CIRCLE ON RIGHT SIDE OF SHEET SIGNIFIES "GO TO NEXT SHEET" AND FIND SAME NUMBER ON LEFT SIDE OF SHEET WITH MATCHING WIRE NUMBER(S).
 - 12 REFER TO ADS WIRING DIAGRAM.
 - 13 REFER TO ATAS WIRING DIAGRAM.

Figure FO-18. SCAS, Hydraulic, and Standby Attitude Gyro System Wiring Diagram (OH-58D(R)) (Sheet 6 of 6)

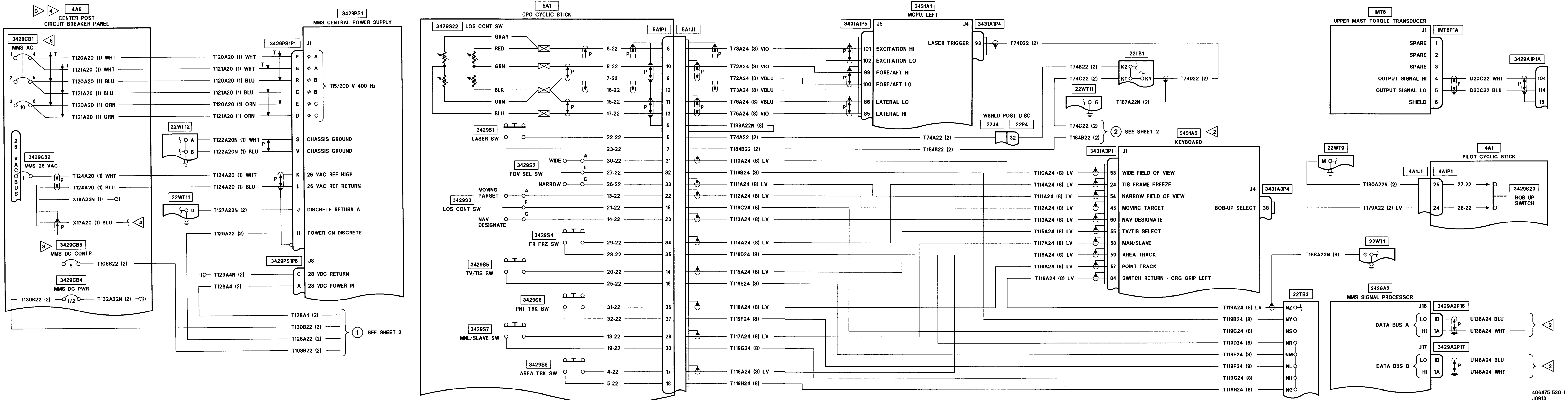

Figure FO-20. Mast Mounted Sight (MMS) System Wiring Diagram (OH-58D(R)) (Sheet 1 of 5)

406475-530-1
J0913

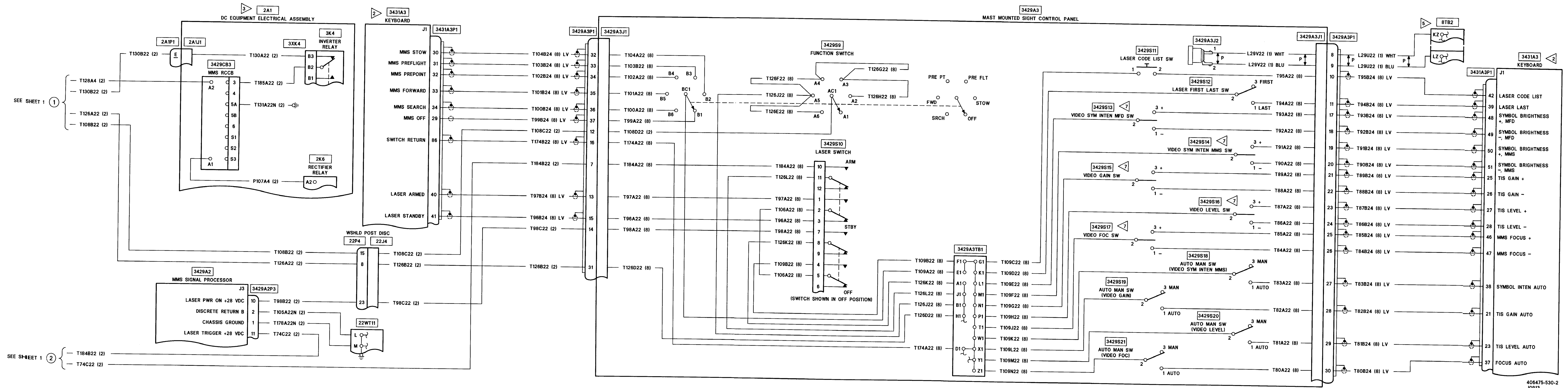

Figure FO-20. Mast Mounted Sight (MMS) System Wiring Diagram (OH-58D(R)) (Sheet 2 of 5)

406475-530-2
J0913

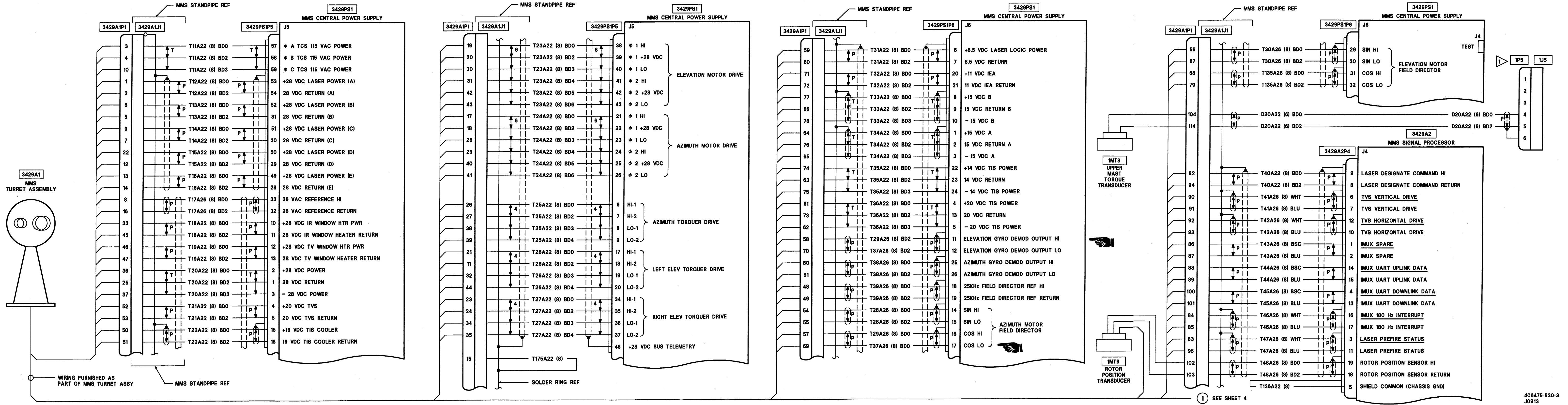
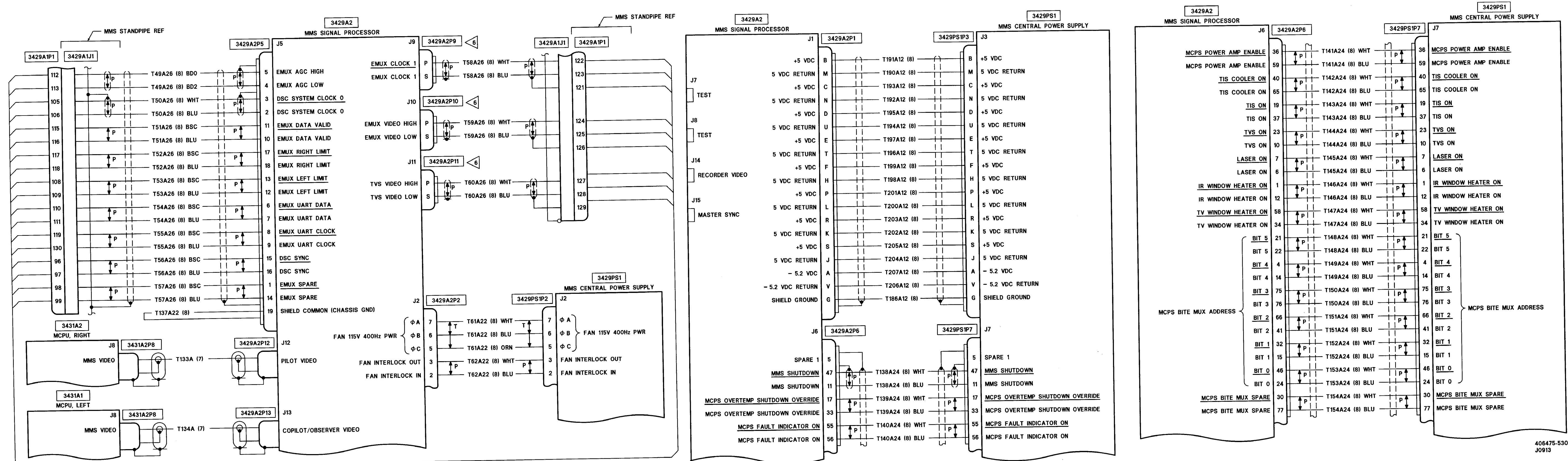

Figure FO-20. Mast Mounted Sight (MMS) System Wiring Diagram (OH-58D(R)) (Sheet 3 of 5)

406475-530-3
J0913



SEE SHEET 3 ①

Figure FO-20. Mast Mounted Sight (MMS) System Wiring Diagram (OH-58D(R)) (Sheet 4 of 5)

406475-530-4
J0913

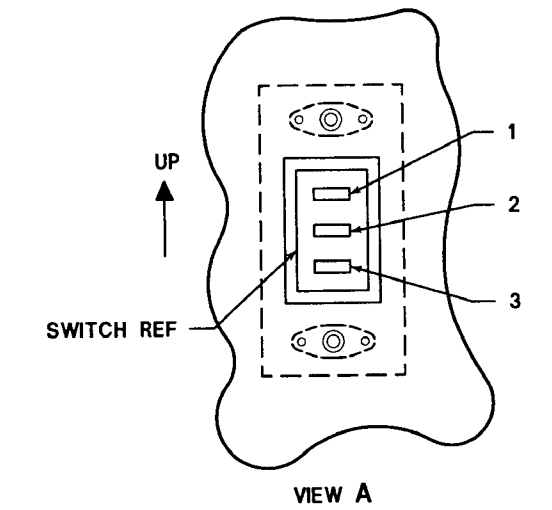
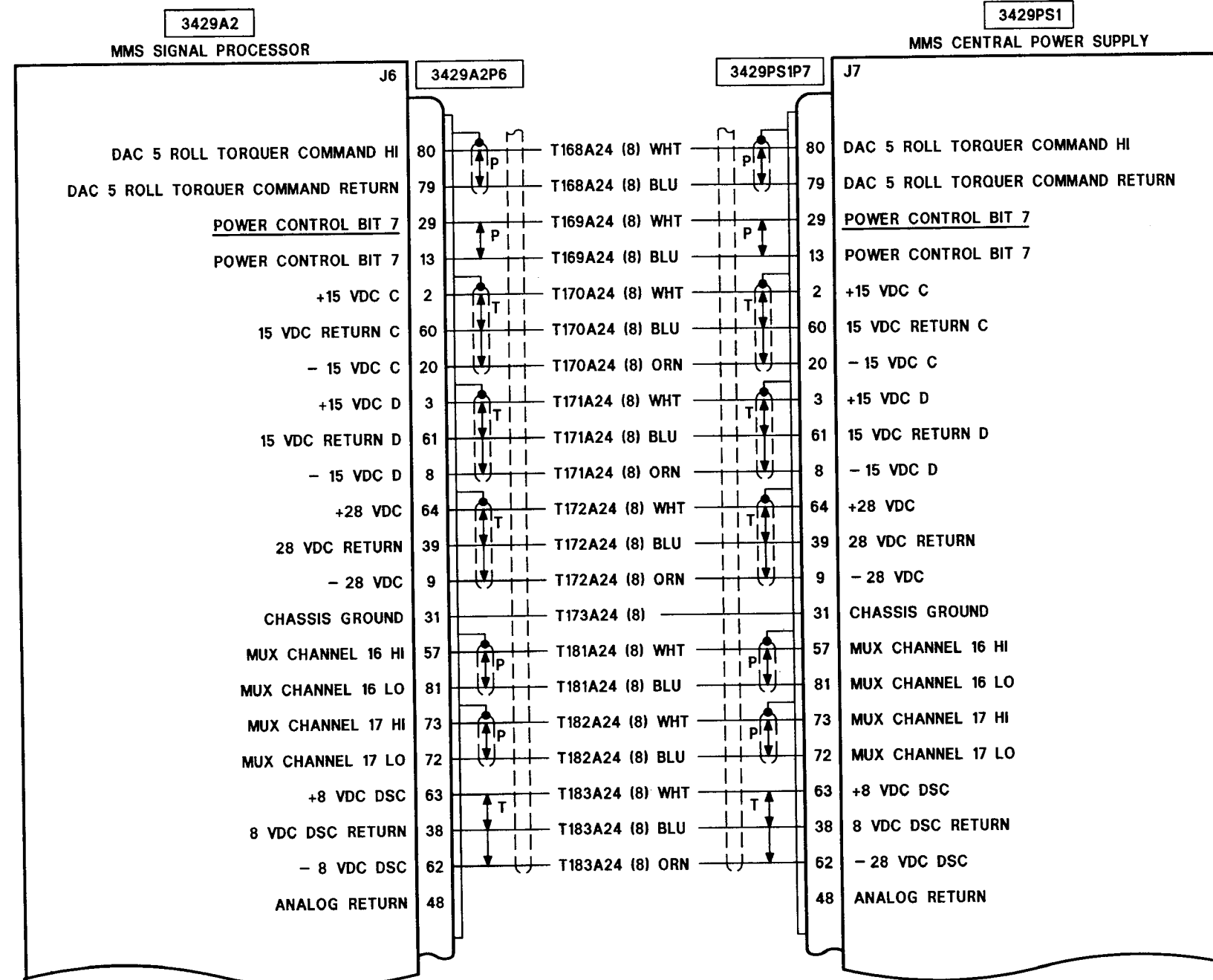
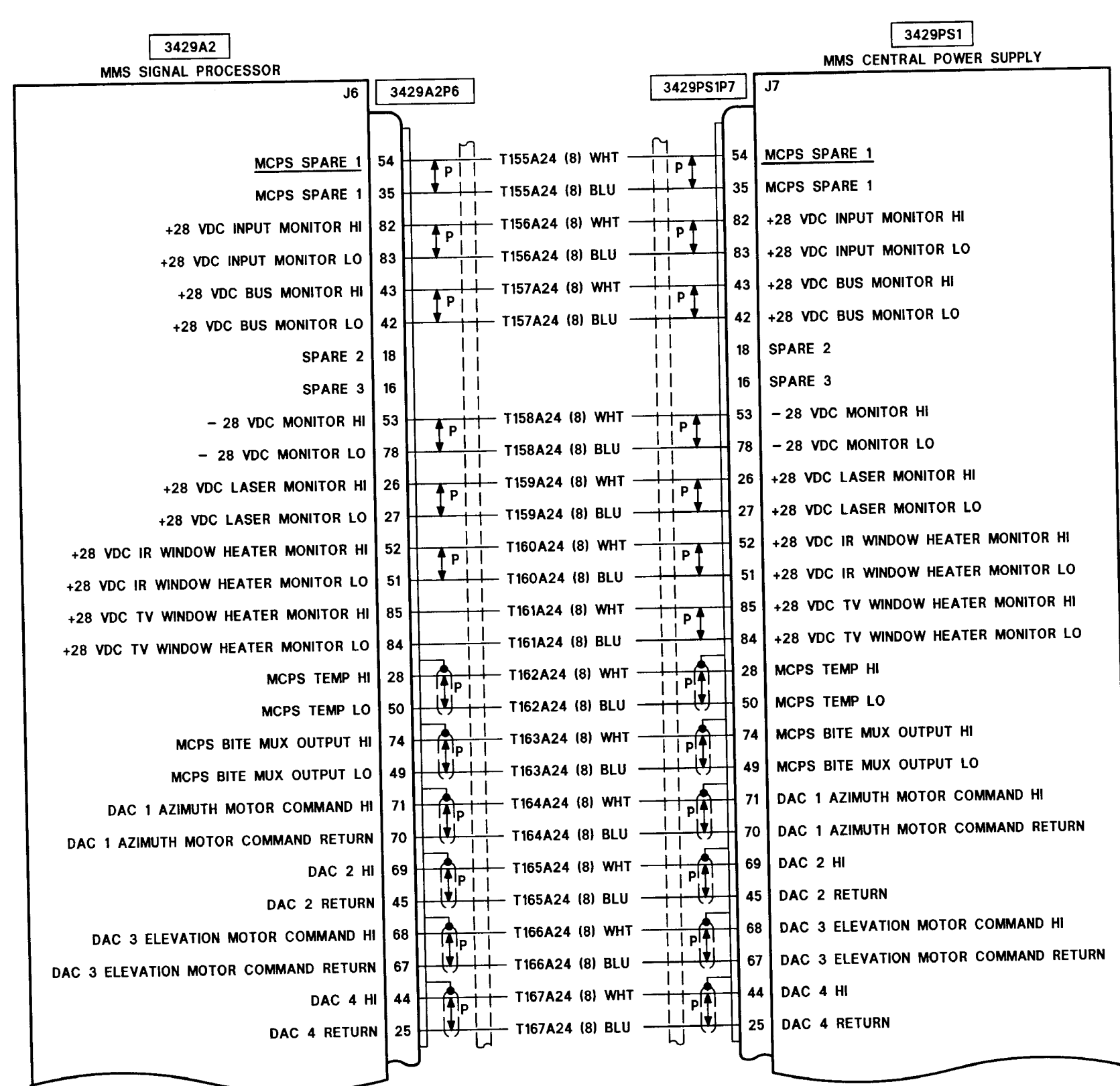

- NOTES
- 1 REFER TO POWERPLANT AND TRANSMISSION SYSTEM WIRING DIAGRAM.
 - 2 REFER TO CONTROL DISPLAY SYSTEM (CDS) WIRING DIAGRAM.
 - 3 REFER TO DC POWER SYSTEM WIRING DIAGRAM.
 - 4 REFER TO AC POWER SYSTEM WIRING DIAGRAM.
 - 5 REFER TO LIGHTING SYSTEM WIRING DIAGRAM.
 - 6 FURNISHED CONNECTOR CONTACT IDENTIFICATION FOR TERMINATING A 2-CONDUCTOR SHIELDED, JACKETED CABLE SHALL BE AS FOLLOWS:
P = PIN CONTACT
S = SOCKET CONTACT
 - 7 SEE VIEW A FOR SWITCH TERMINAL IDENTIFICATION.
 - 8 VIEW LOOKING AT REAR OF CIRCUIT BREAKER. NUMBERS WILL READ FROM LEFT TO RIGHT WITH 1, 2, AND 3 ON THE TOP, OR KEYWAY SIDE.
 - 9. NUMBERED CIRCLE ON RIGHT SIDE OF SHEET SIGNIFIES "GO TO NEXT SHEET" AND FIND SAME NUMBER ON LEFT SIDE OF SHEET WITH MATCHING WIRE NUMBER(S).

Figure FO-20. Mast Mounted Sight (MMS) System Wiring Diagram (OH-58D(R)) (Sheet 5 of 5)

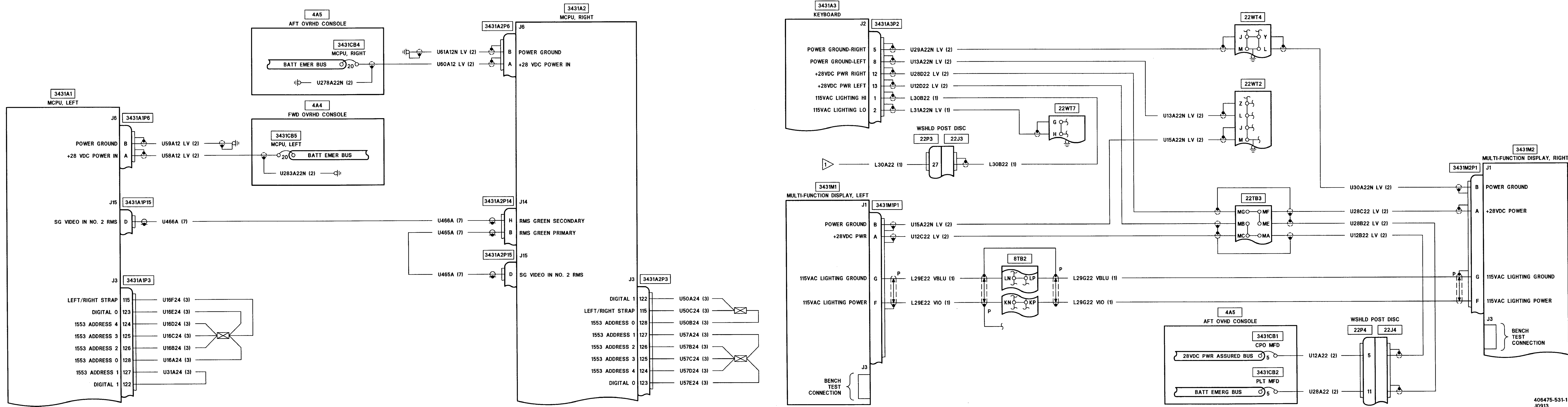

406475-531-1
J0913

Figure FO-21. Control Display System (CDS) Wiring Diagram (OH-58D(R)) (Sheet 1 of 10)

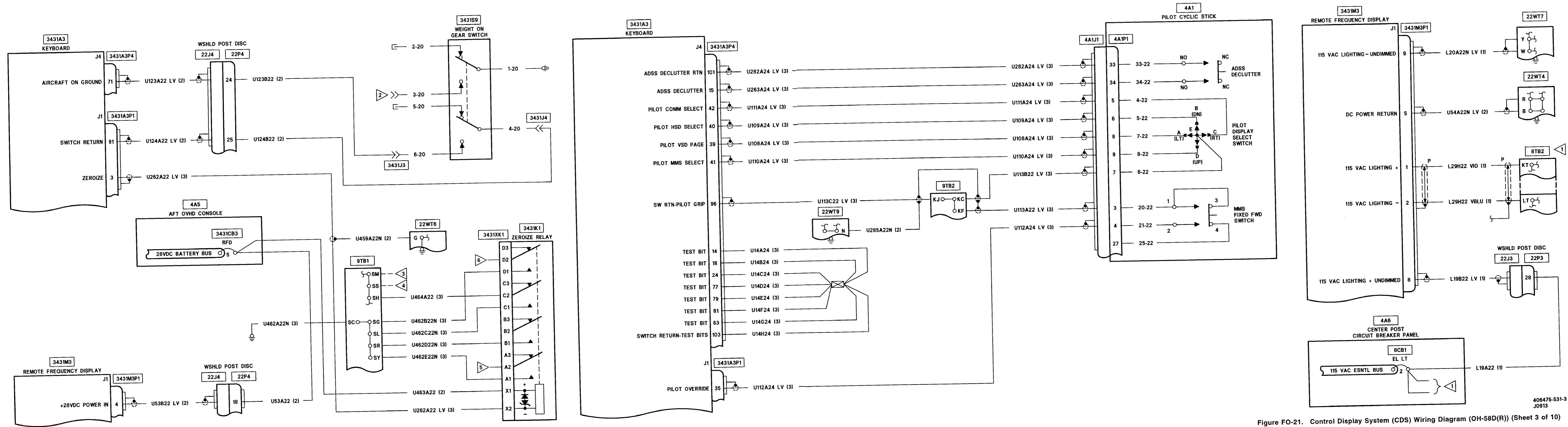

Figure FO-21. Control Display System (CDS) Wiring Diagram (OH-58D(R)) (Sheet 3 of 10)

406475-531-3
J0913

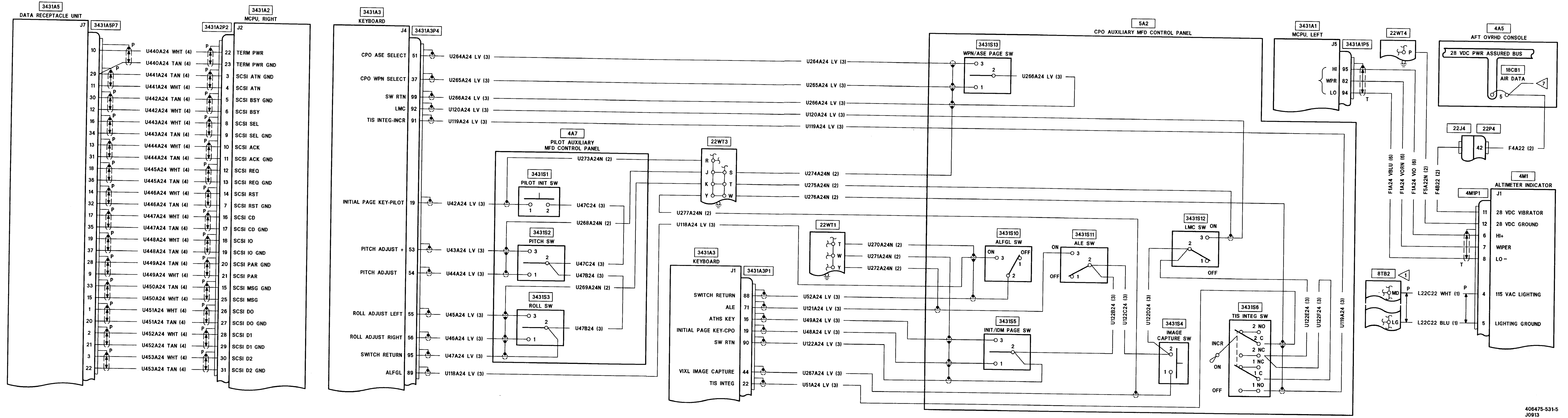

Figure FO-21. Control Display System (CDS) Wiring Diagram (OH-58D(R)) (Sheet 5 of 10)

406475-531-5
J0913

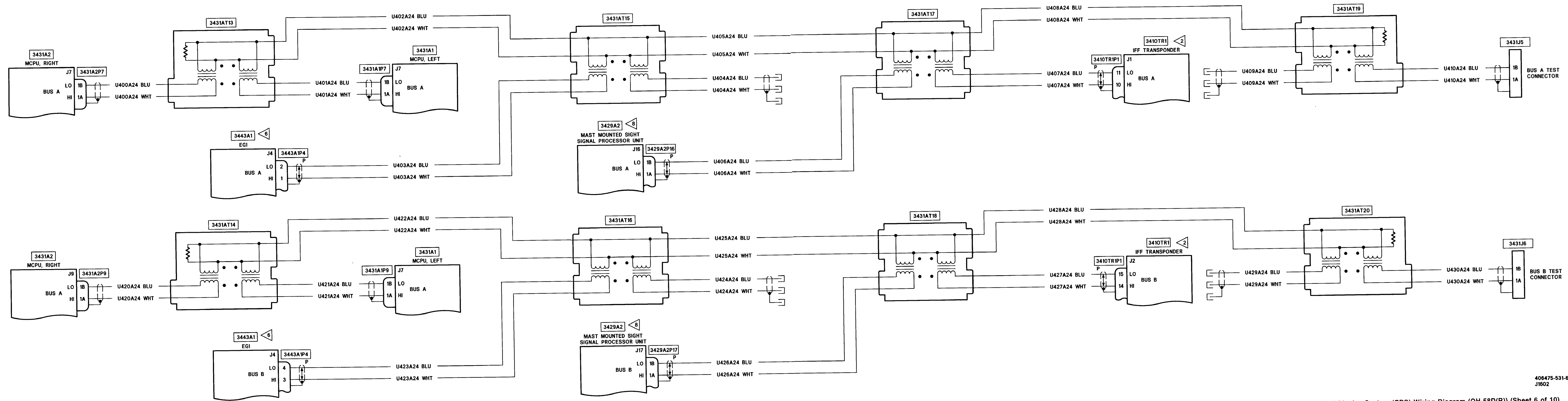

Figure FO-21. Control Display System (CDS) Wiring Diagram (OH-58D(R)) (Sheet 6 of 10)

406475-531-6
J1602

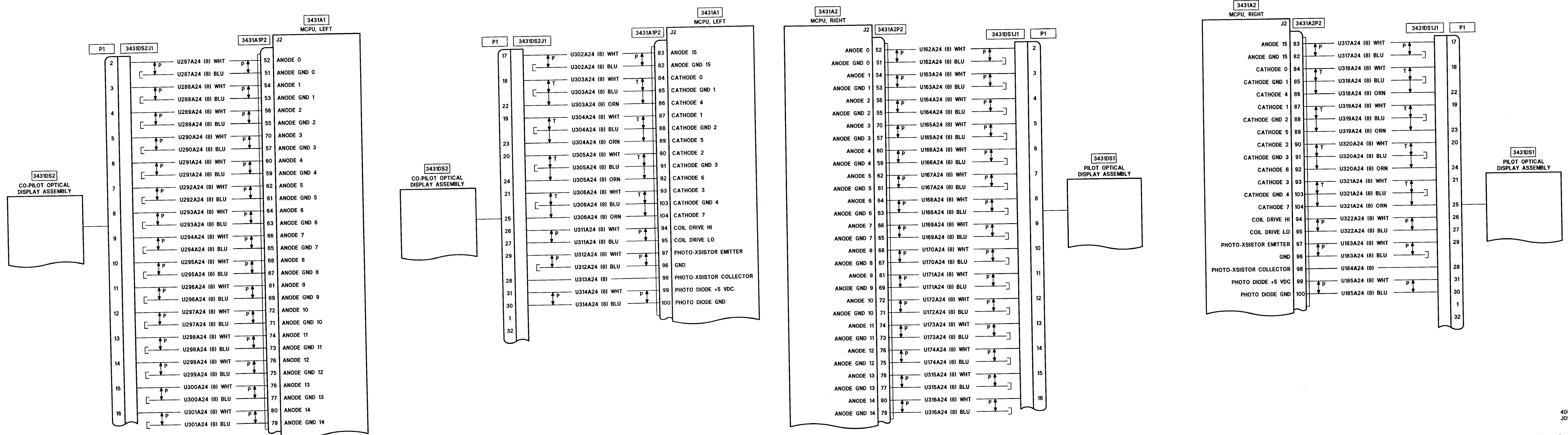

Figure FO-21. Control Display System (CDS) Wiring Diagram (OH-58D(R)) (Sheet 8 of 10)

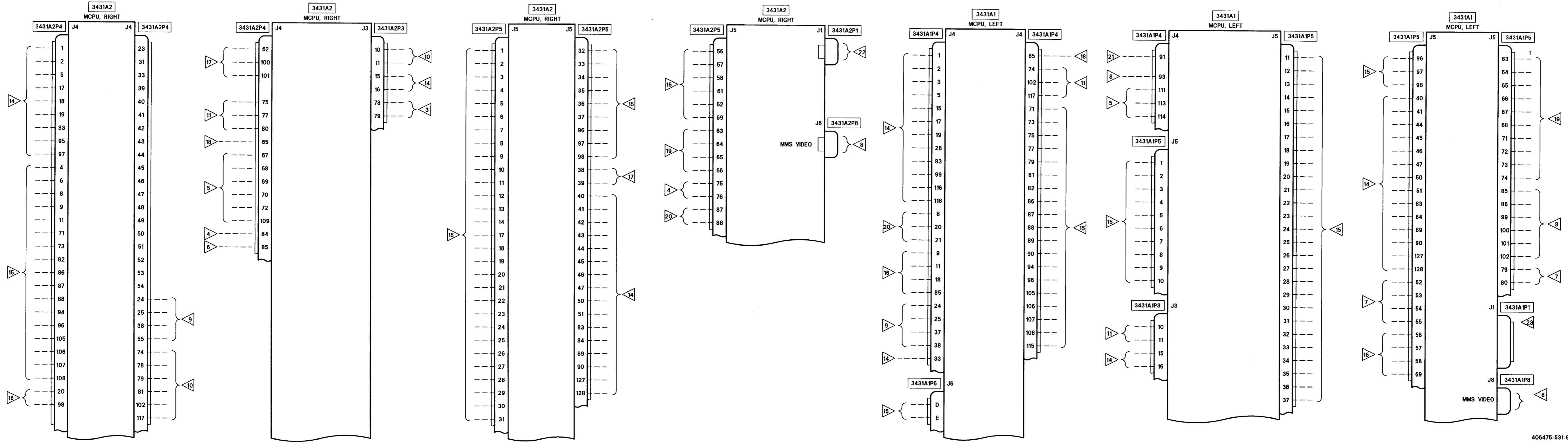
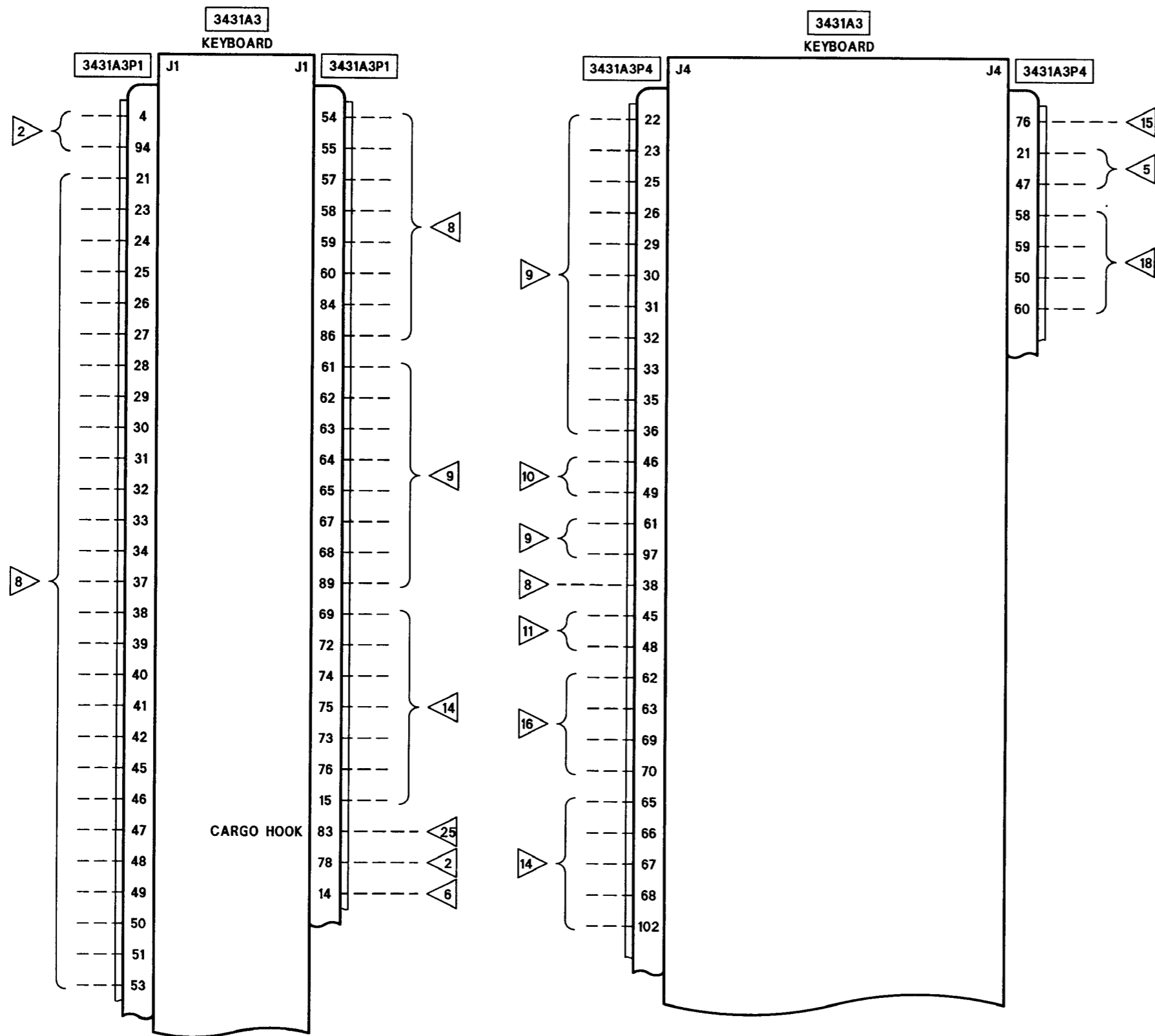

Figure FO-21. Control Display System (CDS) Wiring Diagram (OH-58D(R)) (Sheet 9 of 10)

406475-531-9
J0913



- NOTES**
- 1 REFER TO LIGHTING WIRING DIAGRAM.
 - 2 REFER TO IFF WIRING DIAGRAM TM 11-1520-248-23.
 - 3 REFER TO NO. 1 VHF-FM COMM WIRING DIAGRAM TM 11-1520-248-23.
 - 4 REFER TO NO. 2 VHF-FM COMM WIRING DIAGRAM TM 11-1520-248-23.
 - 5 REFER TO HF WIRING DIAGRAM TM 11-1520-248-23.
 - 6 REFER TO EGI WIRING DIAGRAM TM 11-1520-248-23.
 - 7 REFER TO AIR DATA SYSTEM WIRING DIAGRAM TM 11-1520-248-23.
 - 8 REFER TO MAST MOUNTED SIGHT (MMS) SYSTEM WIRING DIAGRAM.
 - 9 REFER TO ICS WIRING DIAGRAM TM 11-1520-248-23.
 - 10 REFER TO VHF-AM COMM WIRING DIAGRAM TM 11-1520-248-23.
 - 11 REFER TO UHF-AM COMM WIRING DIAGRAM TM 11-1520-248-23.
 - 12 REFER TO IDM WIRING DIAGRAM TM 11-1520-248-23.
 - 13 REFER TO HELLFIRE SYSTEM WIRING DIAGRAM.
 - 14 REFER TO POWERPLANT AND TRANSMISSION WIRING DIAGRAM.
 - 15 REFER TO SCAS, HYDRAULICS, AND STANDBY ATTITUDE GYRO SYSTEM WIRING DIAGRAM.
 - 16 REFER TO DC POWER SYSTEM WIRING DIAGRAM.
 - 17 REFER TO RADAR ALTIMETER WIRING DIAGRAM TM 11-1520-248-23.
 - 18 REFER TO GUNS AND ROCKETS SYSTEM WIRING DIAGRAM.
 - 19 REFER TO TRANSMISSION ATTITUDE MEASUREMENT SYSTEM WIRING DIAGRAM.
 - 20 REFER TO AC POWER SYSTEM WIRING DIAGRAM.

Figure FO-21. Control Display System (CDS) Wiring Diagram (OH-58D(R)) (Sheet 10 of 10)

406475-531-10
J1602

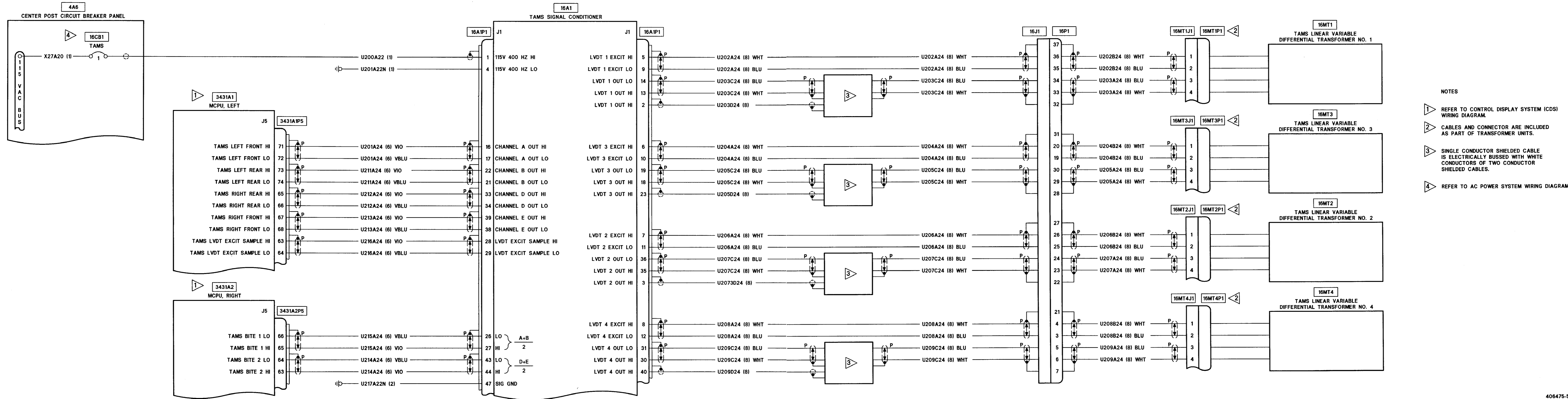

406475-533
J0913

Figure FO-22. Transmission Attitude Measurement System (TAMS) Wiring Diagram (OH-58D(R))

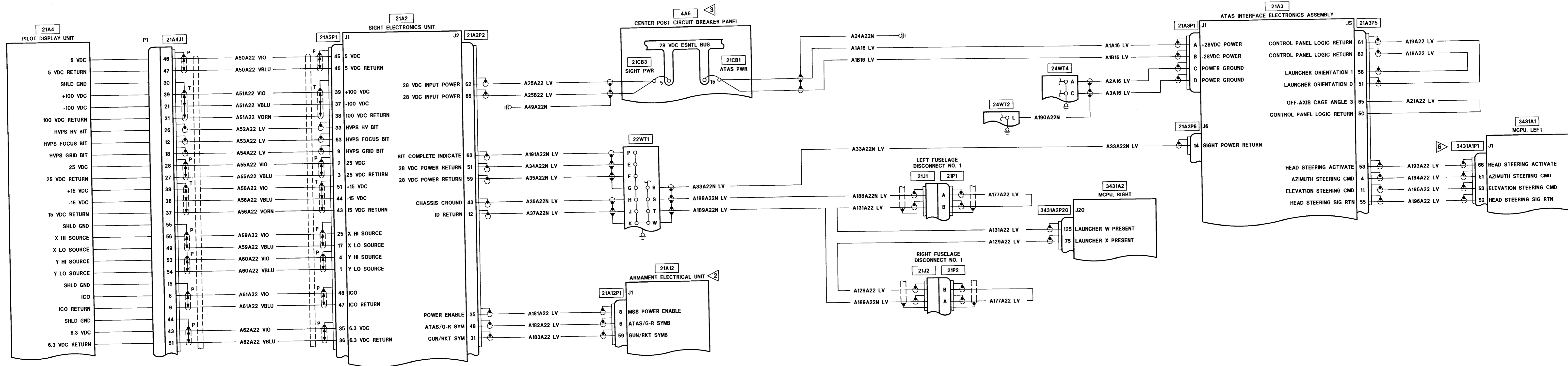

Figure FO-23. Air-to-Air Stinger (ATAS) Missile System Wiring Diagram (OH-58D(R)) (Sheet 1 of 6)

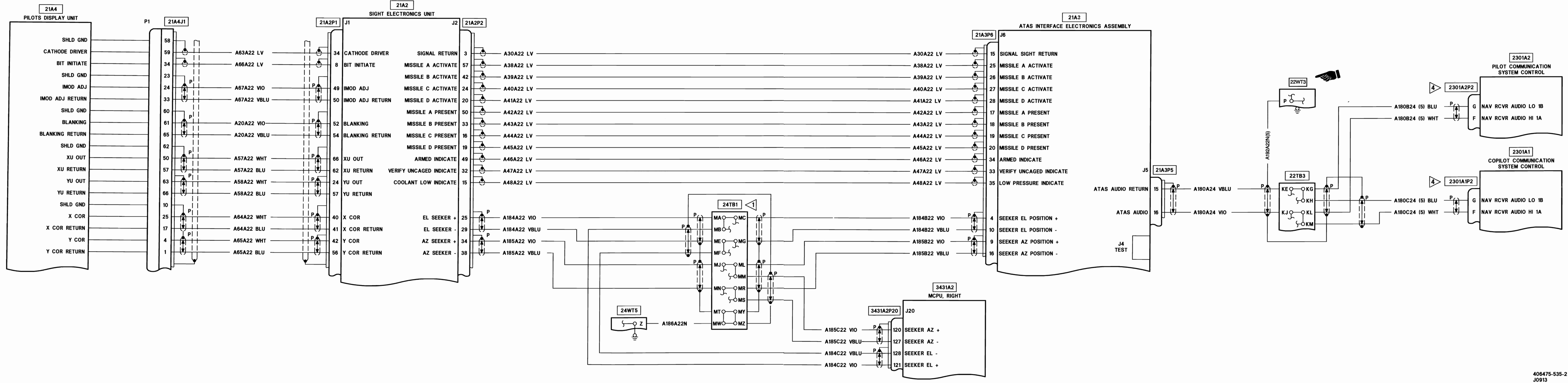

Figure FO-23. Air-to-Air Stinger (ATAS) Missile System Wiring Diagram (OH-58D(R)) (Sheet 2 of 6)

406475-535-2
J0913

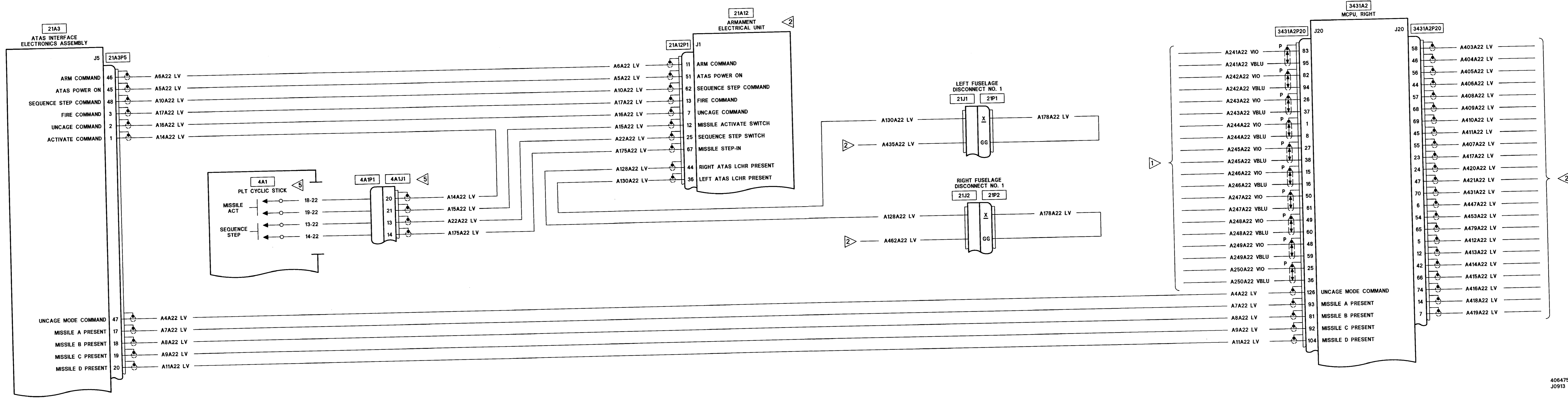
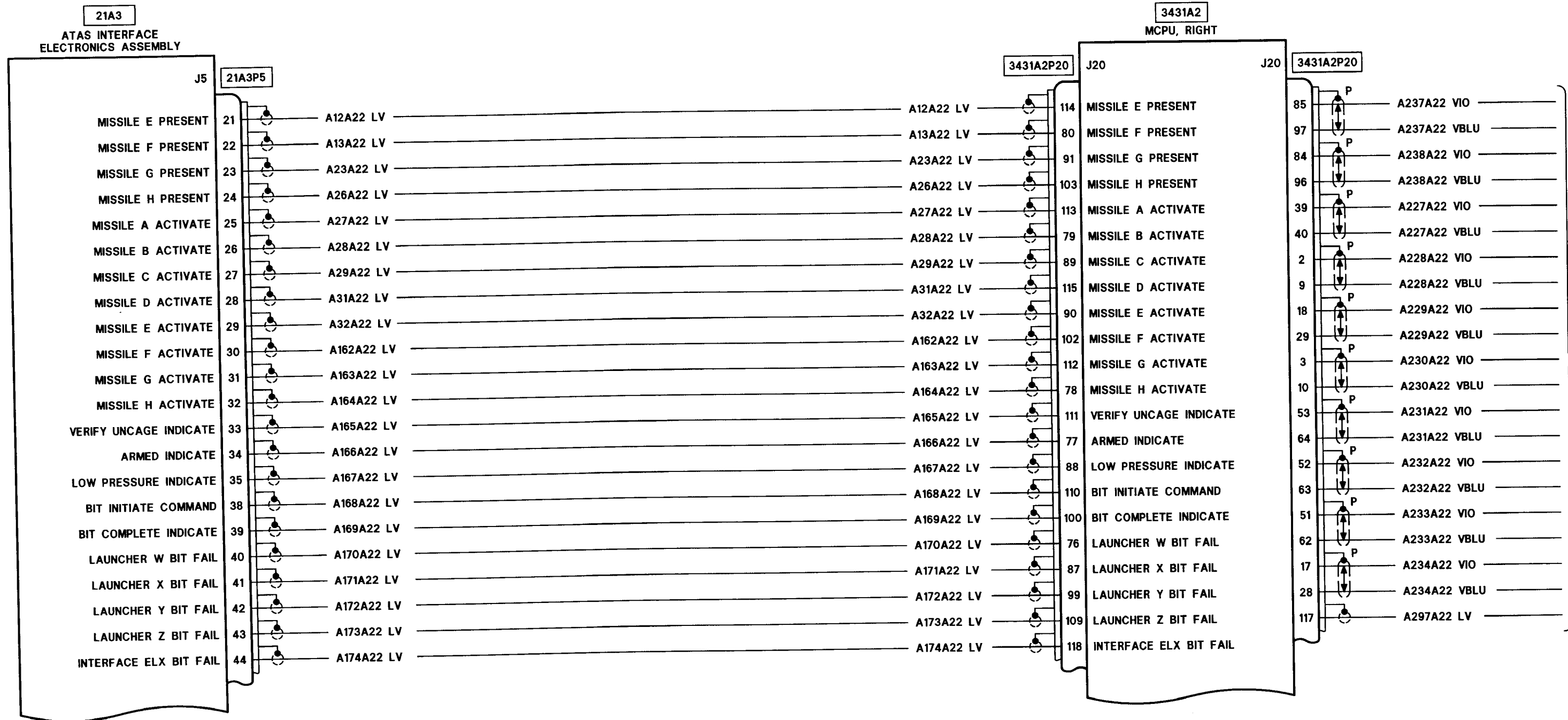

Figure FO-23. Air-to-Air Stinger (ATAS) Missile System Wiring Diagram (OH-58D(R)) (Sheet 3 of 6)

406475-535-3
J0913



406475-535-4
J0913

Figure FO-23. Air-to-Air Stinger (ATAS) Missile System Wiring Diagram (OH-58D(R)) (Sheet 4 of 6)

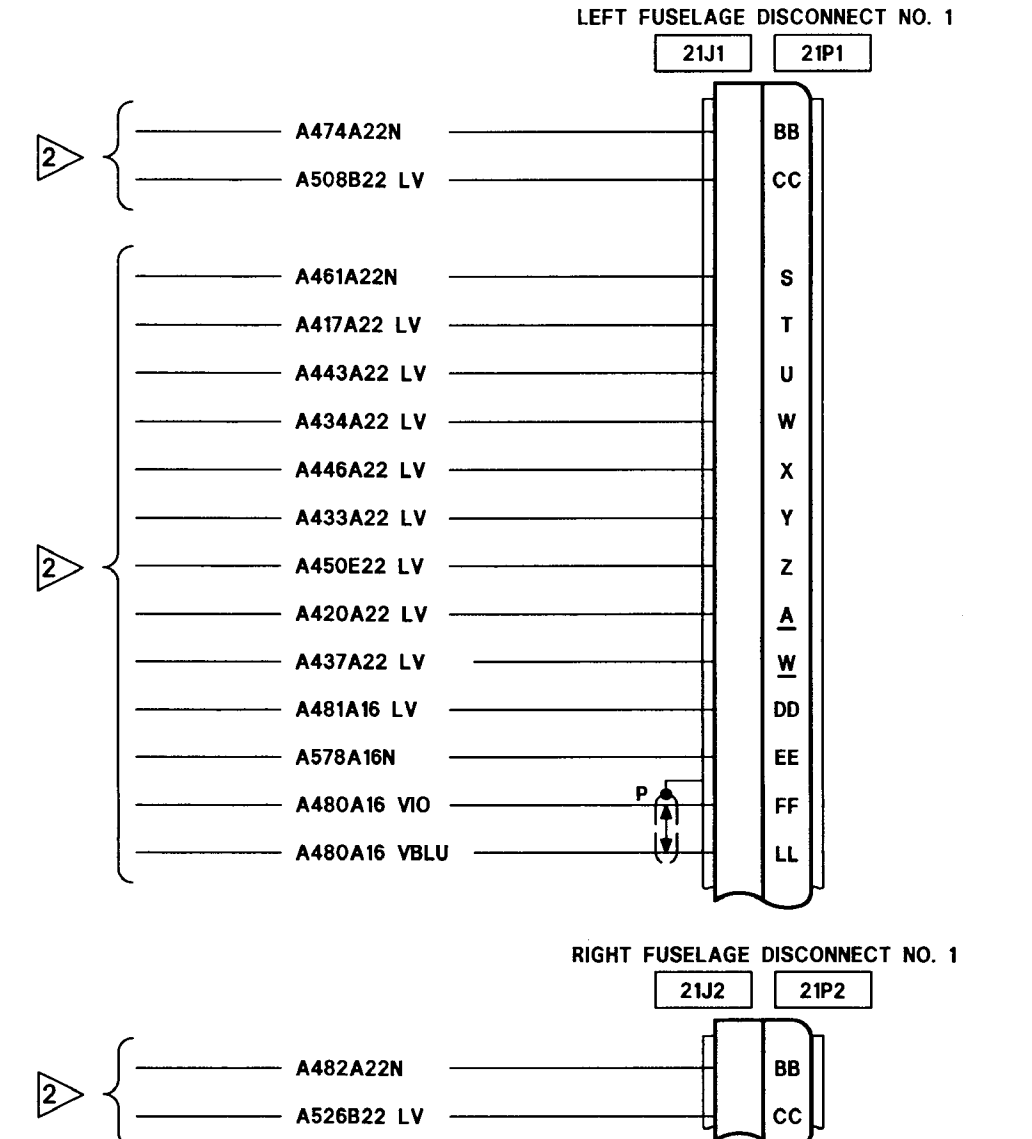
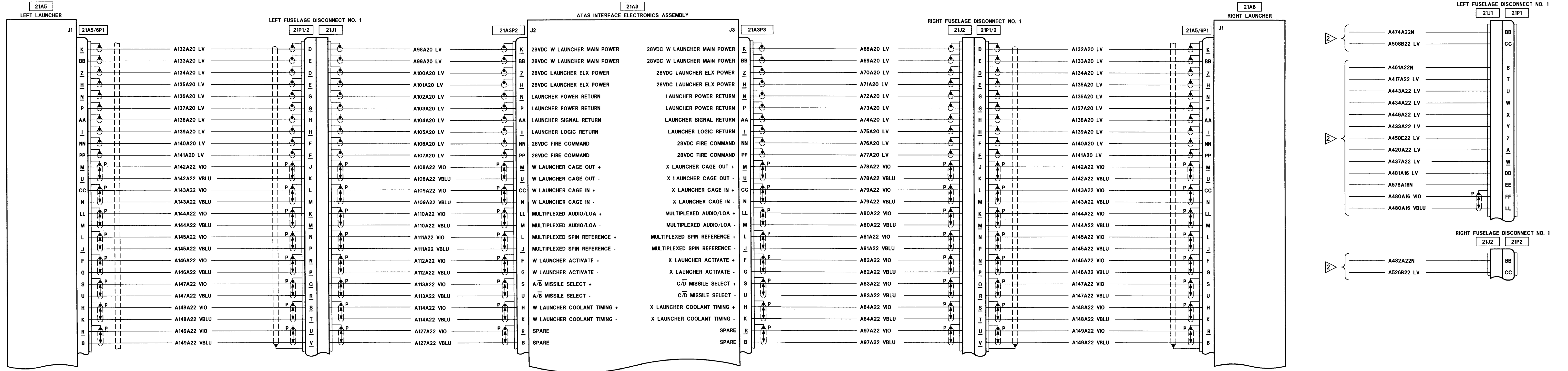
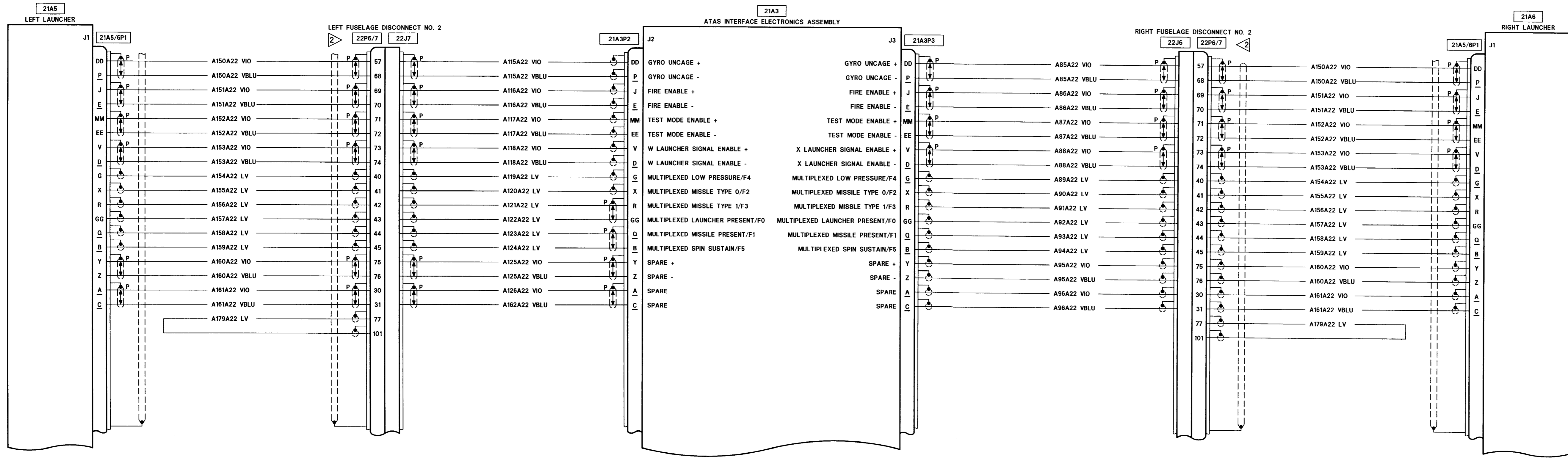

Figure FO-23. Air-to-Air Stinger (ATAS) Missile System Wiring Diagram (OH-58D(R)) (Sheet 5 of 6)



- NOTES:
- 1 REFER TO HELLFIRE SYSTEM WIRING DIAGRAM.
 - 2 REFER TO GUNS AND ROCKETS WIRING DIAGRAM.
 - 3 REFER TO DC POWER SYSTEM WIRING DIAGRAM.
 - 4 REFER TO ICS SYSTEM WIRING DIAGRAM TM 11-1520-248-23.
 - 5 REFER TO SCAS, HYDRAULIC, AND STANDBY ATTITUDE GYRO SYSTEM WIRING DIAGRAM.
 - 6 REFER TO VIDEO TAPE RECORDER WIRING DIAGRAM. TM 11-1520-248-23.

Figure FO-23. Air-to-Air Stinger (ATAS) Missile System Wiring Diagram (OH-58D(R)) (Sheet 6 of 6)

406475-535-6
J0913

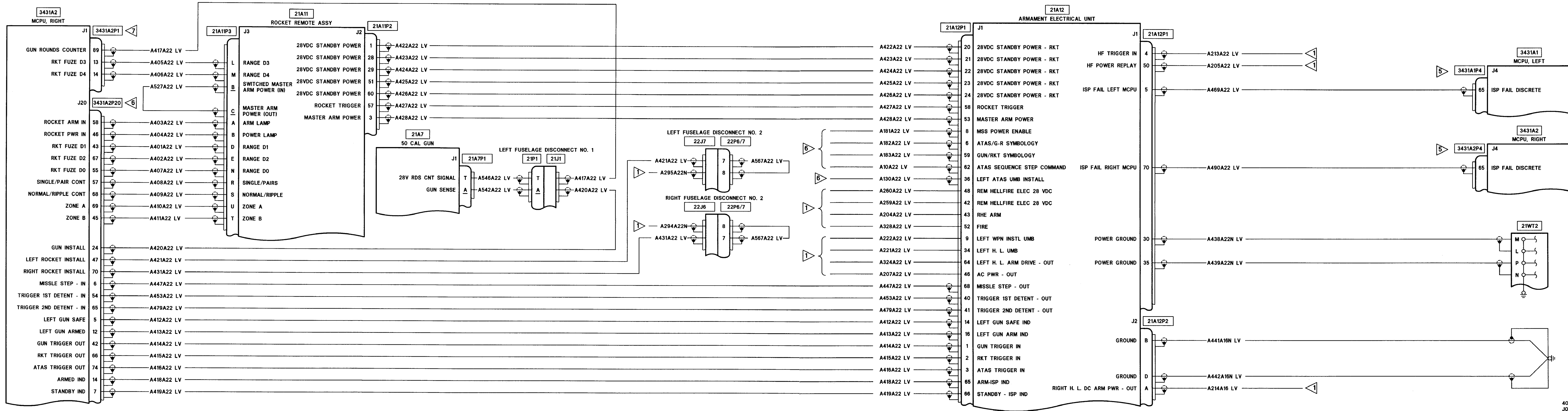

406475-536-1
J0913

Figure FO-24. Guns and Rockets System Wiring Diagram (OH-58D(R)) (Sheet 1 of 4)

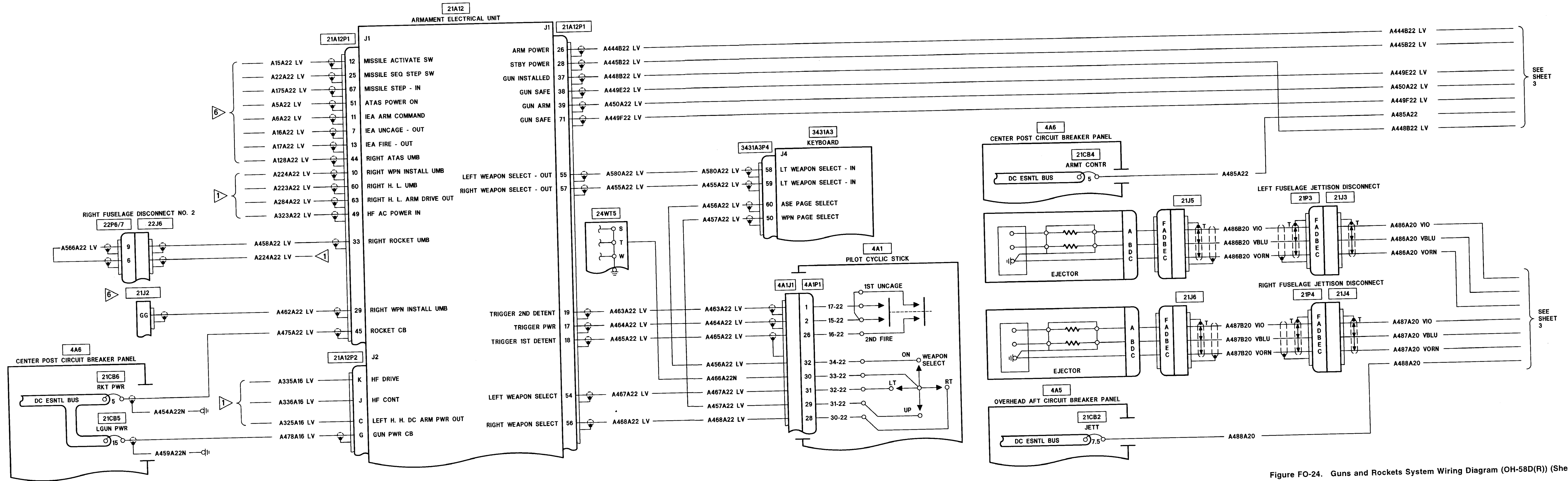

SEE SHEET 3

SEE SHEET 3

406475-536-2 J0913

Figure FO-24. Guns and Rockets System Wiring Diagram (OH-58D(R)) (Sheet 2 of 4)

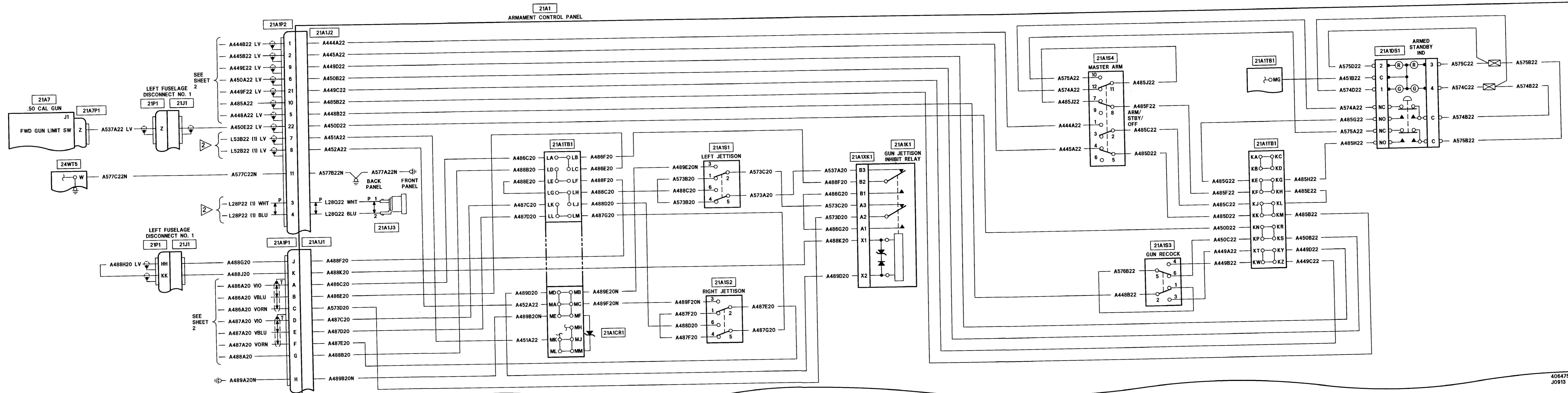
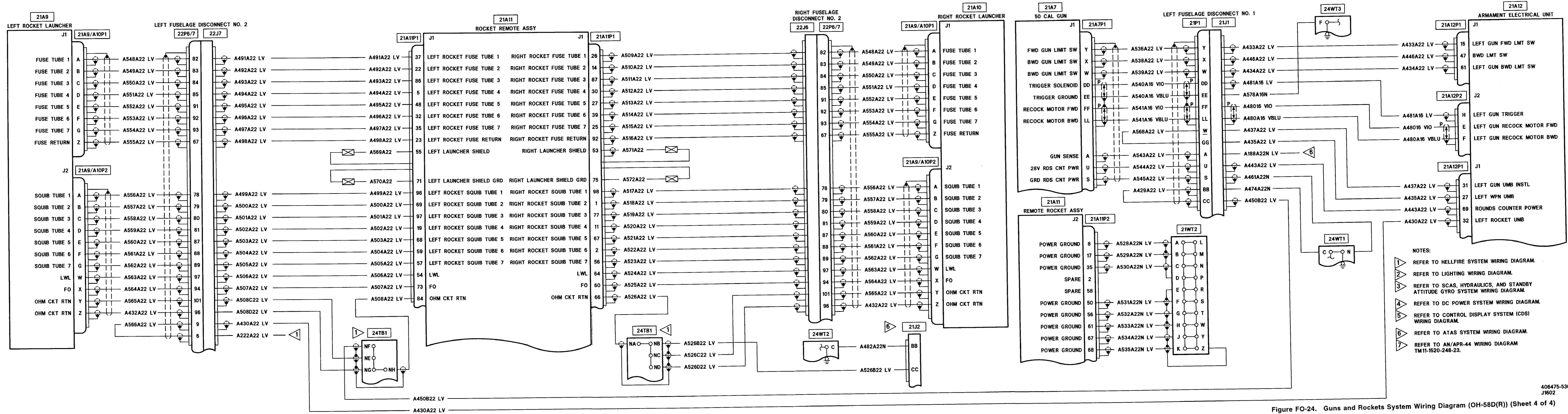

Figure FO-24. Guns and Rockets System Wiring Diagram (OH-58D(R)) (Sheet 3 of 4)

406475-536-3
J0913



- NOTES:
- 1 REFER TO HELLFIRE SYSTEM WIRING DIAGRAM.
 - 2 REFER TO LIGHTING WIRING DIAGRAM.
 - 3 REFER TO SCAS, HYDRAULICS, AND STANDBY ATTITUDE GYRO SYSTEM WIRING DIAGRAM.
 - 4 REFER TO DC POWER SYSTEM WIRING DIAGRAM.
 - 5 REFER TO CONTROL DISPLAY SYSTEM (CDS) WIRING DIAGRAM.
 - 6 REFER TO ATAS SYSTEM WIRING DIAGRAM.
 - 7 REFER TO AN/APR-44 WIRING DIAGRAM TM11-1520-248-23.

Figure FO-24. Guns and Rockets System Wiring Diagram (OH-58D(R)) (Sheet 4 of 4)

406475-536-4
J1602

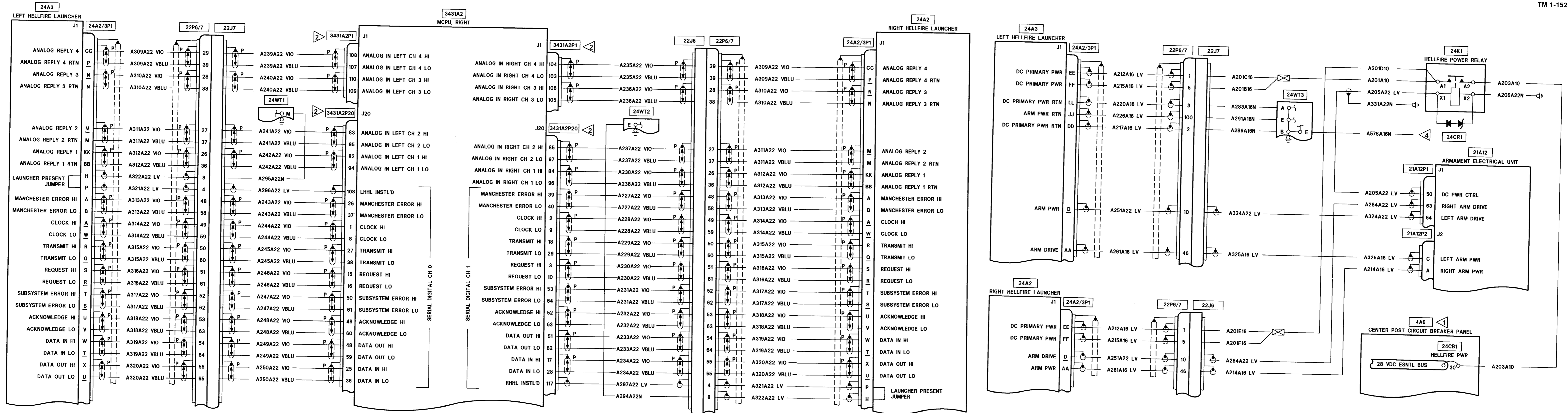

Figure FO-25. HELLFIRE Missile System (HMS) Wiring Diagram (OH-58D(R)) (Sheet 1 of 3)

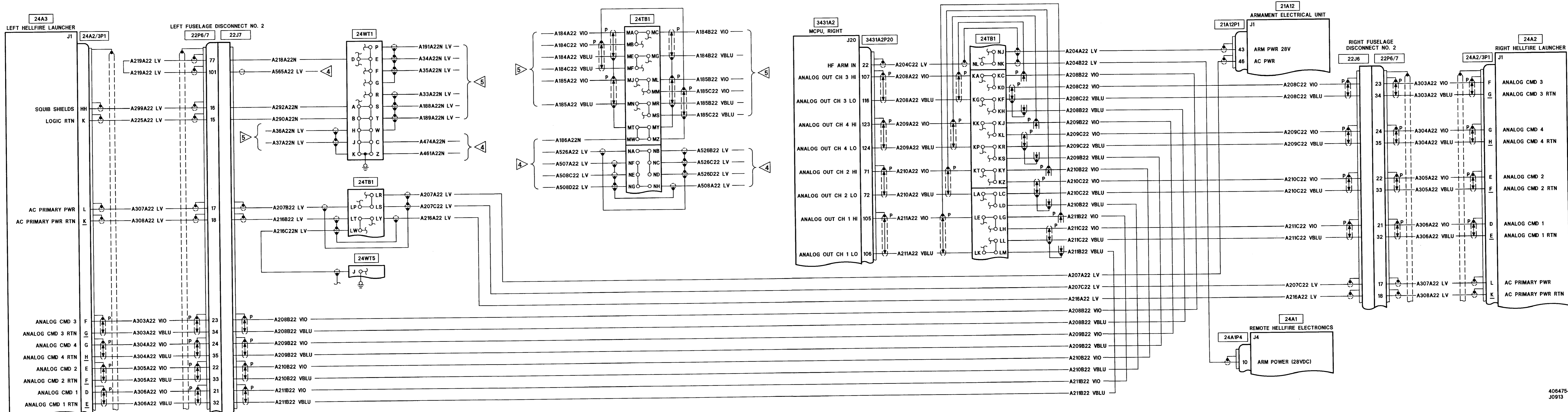

Figure FO-25. HELLFIRE Missile System (HMS) Wiring Diagram (OH-58D(R)) (Sheet 2 of 3)

406475-537-2
J0913

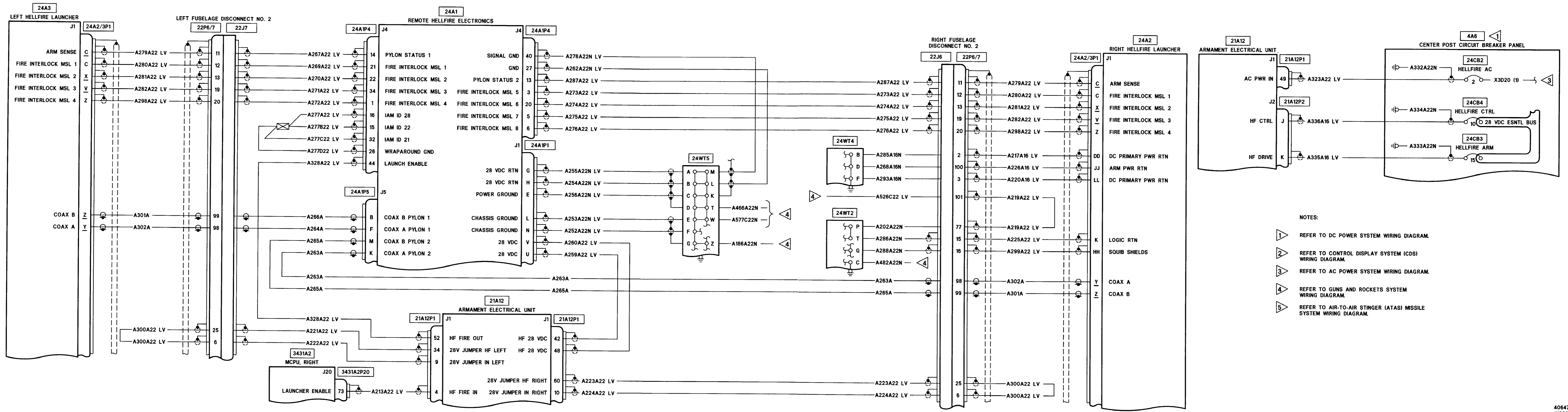
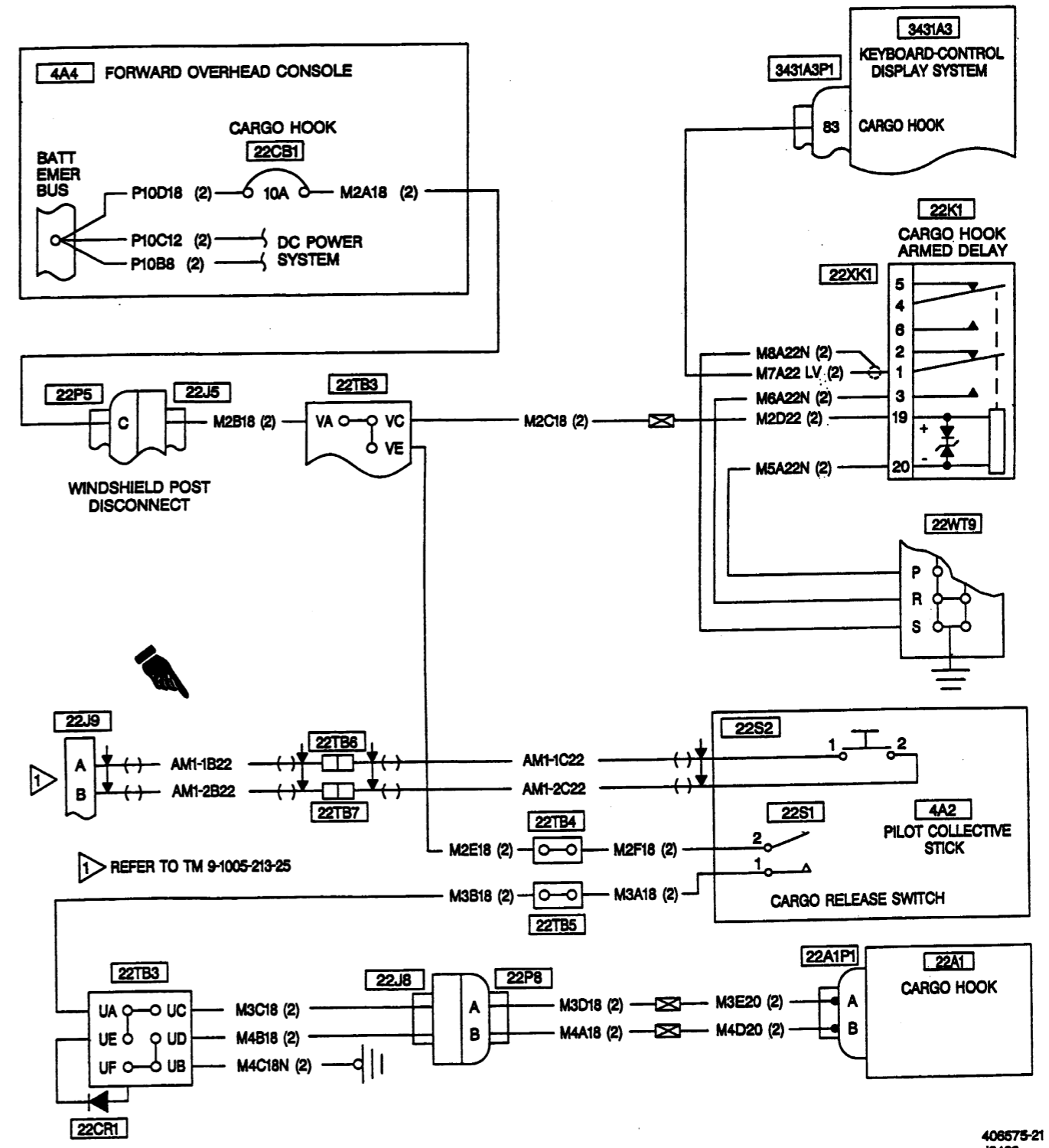

Figure FO-25. HELLFIRE Missile System (HMS) Wiring Diagram (OH-58D(R)) (Sheet 3 of 3)

406475-537-3
J1602



408575-21
J3423

Figure FO-26. Cargo Hook System Wiring Diagram (OH-58D(R))

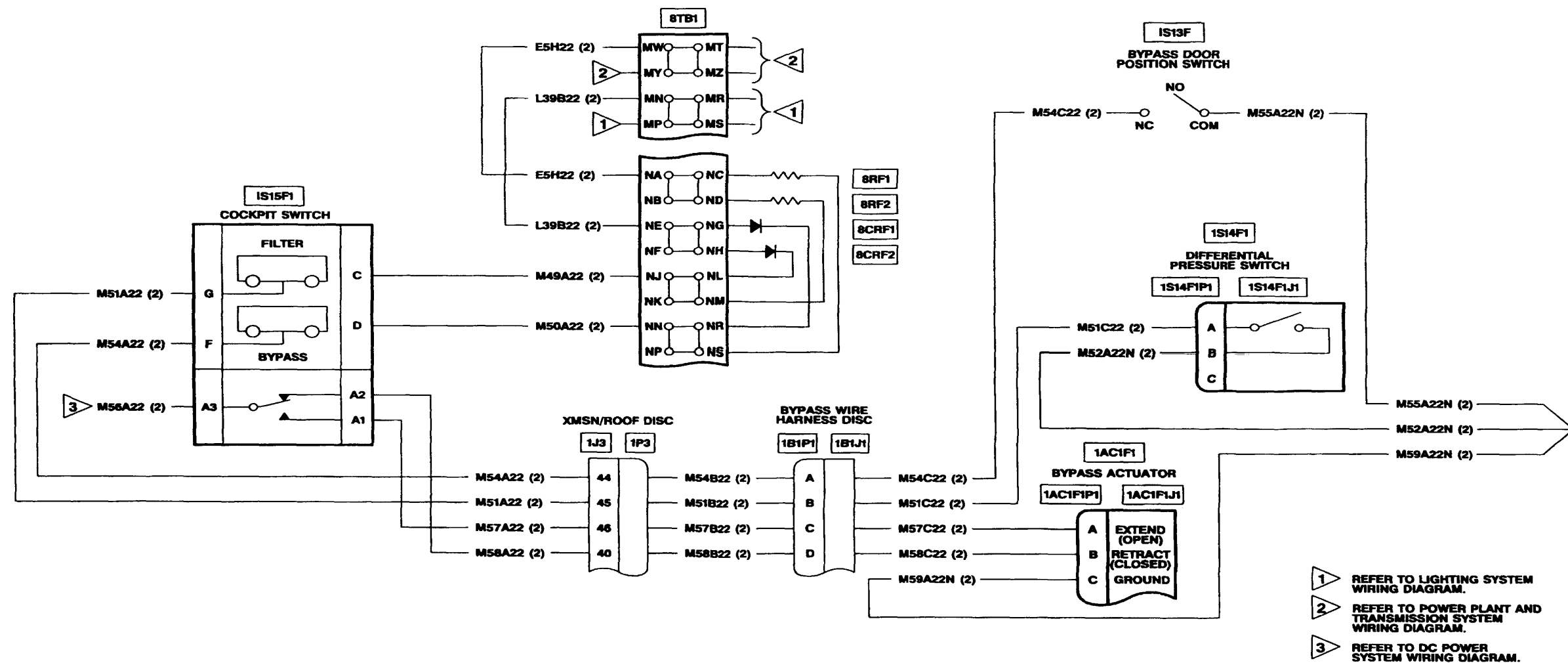

406475-544-18
J3238

Figure FO-26.1 Engine Barrier Filter (EBF) System Wiring Diagram (OH-58D(R))

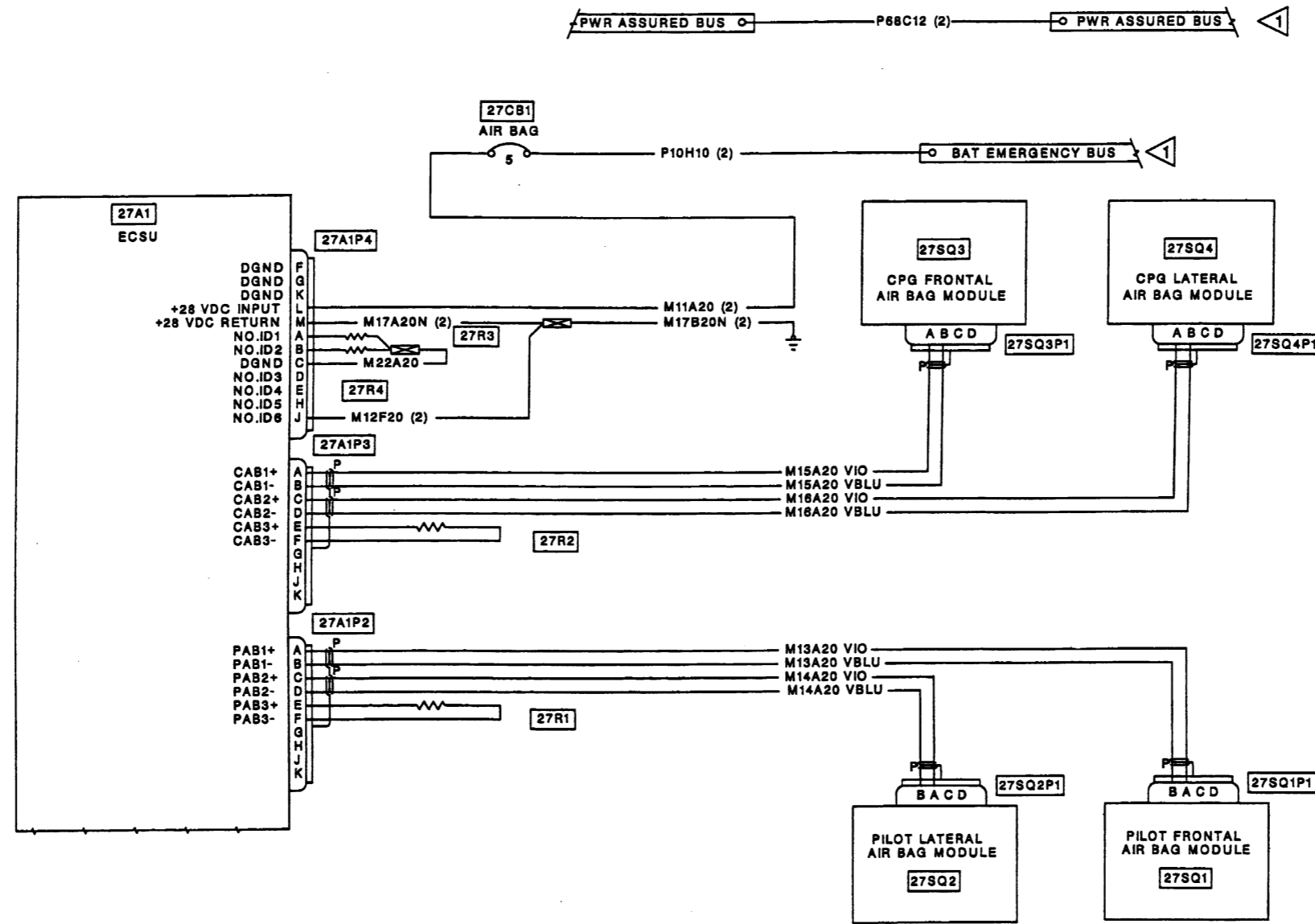

NOTES:
 1 REFER TO DC POWER SYSTEM WIRING DIAGRAM.

406530-79
 J3422

Figure FO-26.2 Cockpit Airbag System (CABS) Wiring Diagram (OH-58D(R))

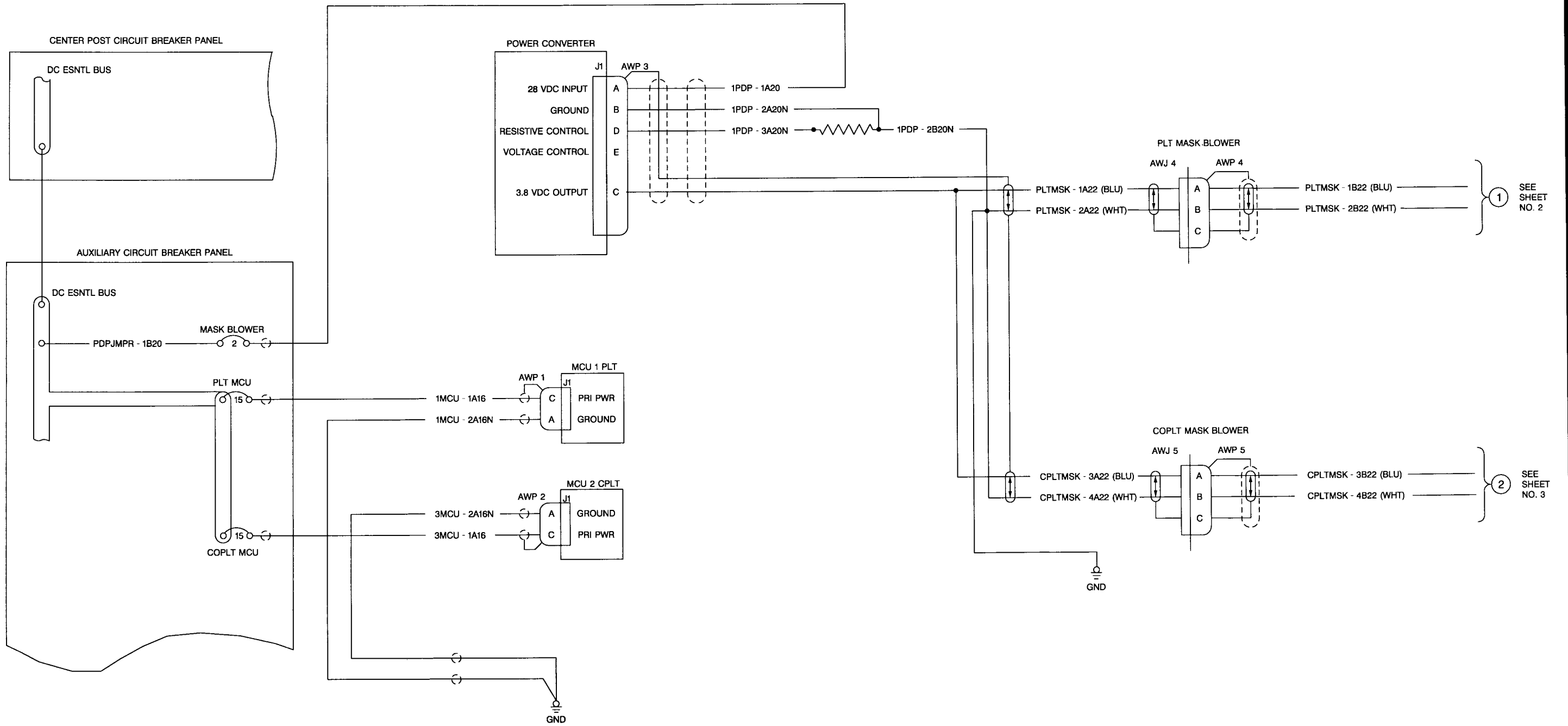

1 SEE SHEET NO. 2

2 SEE SHEET NO. 3

406475 545-1
J3442

Figure FO-27. Microclimate Cooling and Mask Blower Systems Schematic (OH-58D(R)) (Sheet 1 of 3)

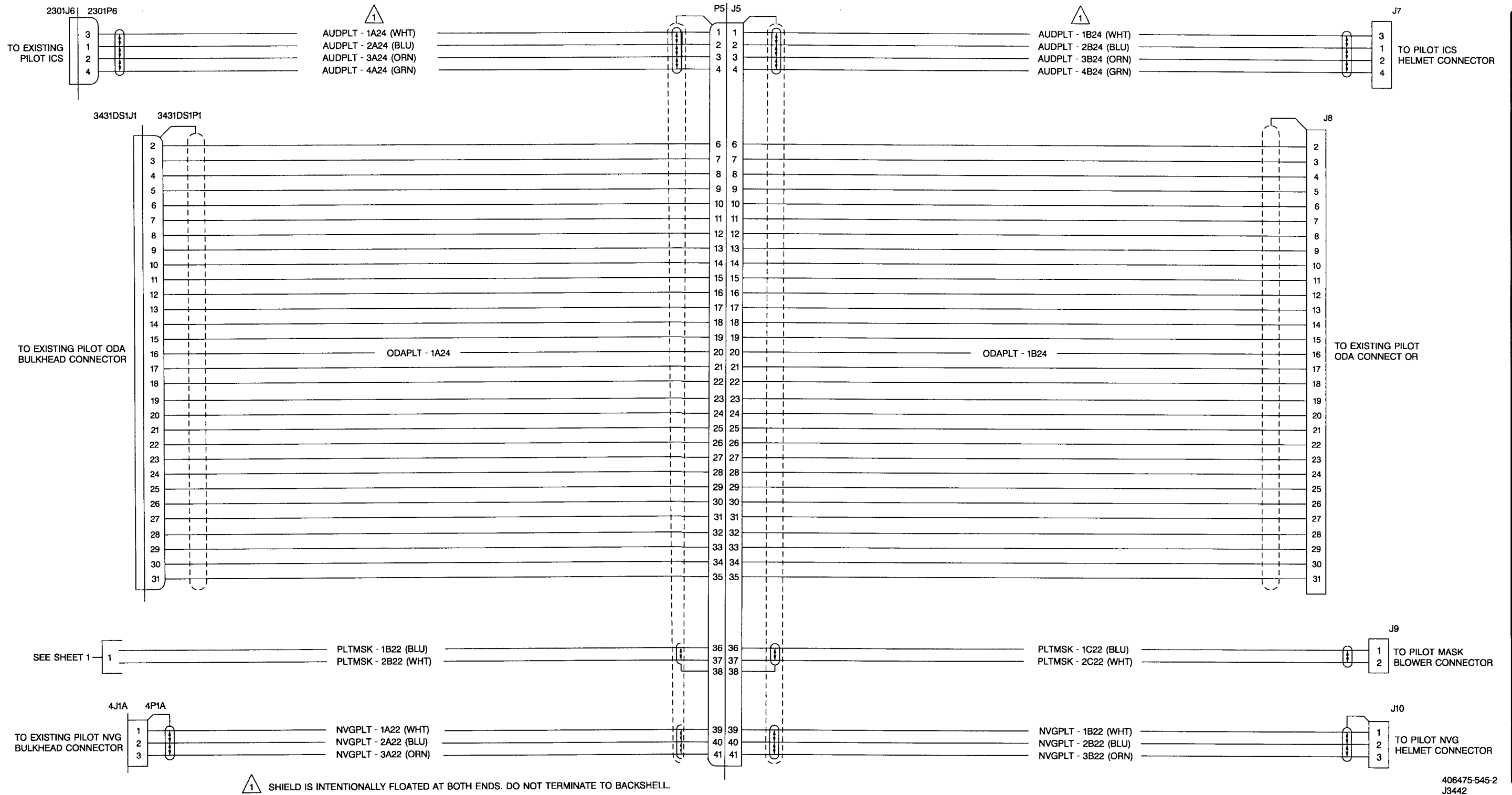

Figure FO-27. Microclimate Cooling and Mask Blower Systems Schematic (OH-58D(R)) (Sheet 2 of 3)

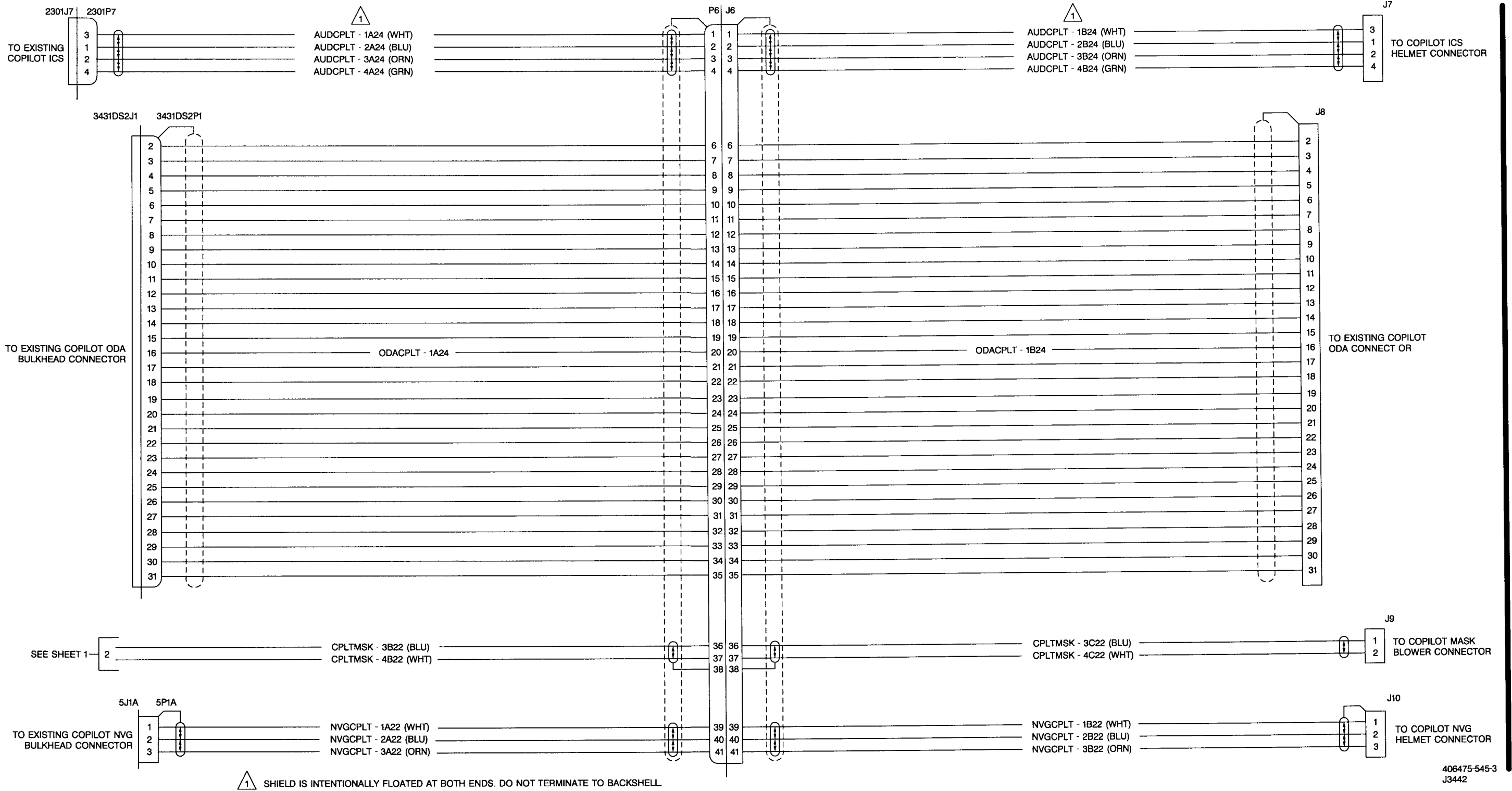
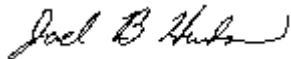

Figure FO-27. Microclimate Cooling and Mask Blower Systems Schematic (OH-58D(R)) (Sheet 3 of 3)

**By Order of the Secretary of the
Army:**

Official:



JOEL B. HUDSON
*Administrative Assistant to the
Secretary of the Army*

9934908

ERIC K. SHINSEKI
*General, United States Army
Chief of Staff*

Distribution:

To be distributed in accordance with Initial Distribution Number (IDN) 311435, requirements for TM 1-1520-248-23-7.

These are the instructions for sending an electronic 2028

The following format must be used if submitting an electronic 2028. The subject line must be exactly the same and all fields must be included; however only the following fields are mandatory: 1, 3, 4, 5, 6, 7, 8, 9, 10, 13, 15, 16, 17, and 27.

From: "Whomever" <whomever@wherever.army.mil>

To: 2028@redstone.army.mil

Subject: DA Form 2028

1. **From:** Joe Smith
2. **Unit:** home
3. **Address:** 4300 Park
4. **City:** Hometown
5. **St:** MO
6. **Zip:** 77777
7. **Date Sent:** 19-OCT-93
8. **Pub no:** 55-2840-229-23
9. **Pub Title:** TM
10. **Publication Date:** 04-JUL-85
11. **Change Number:** 7
12. **Submitter Rank:** MSG
13. **Submitter FName:** Joe
14. **Submitter MName:** T
15. **Submitter LName:** Smith
16. **Submitter Phone:** 123-123-1234
17. **Problem:** 1
18. **Page:** 2
19. **Paragraph:** 3
20. **Line:** 4
21. **NSN:** 5
22. **Reference:** 6
23. **Figure:** 7
24. **Table:** 8
25. **Item:** 9
26. **Total:** 123
27. **Text:**

This is the text for the problem below line 27.

TO: (Forward direct to addressee listed in publication) Commander, U.S. Army Aviation and Missile Command ATTN: AMSAM-MMC-MA-NP Redstone Arsenal, 35898	FROM: (Activity and location) (Include ZIP Code) MSG, Jane Q. Doe 1234 Any Street Nowhere Town, AL 34565	DATE 8/30/02
---	--	------------------------

PART II - REPAIR PARTS AND SPECIAL TOOL LISTS AND SUPPLY CATALOGS/SUPPLY MANUALS

PUBLICATION NUMBER			DATE	TITLE				
PAGE NO.	COLM NO.	LINE NO.	NATIONAL STOCK NUMBER	REFERENCE NO.	FIGURE NO.	ITEM NO.	TOTAL NO. OF MAJOR ITEMS SUPPORTED	RECOMMENDED ACTION

PART III - REMARKS (Any general remarks, corrections, or suggestions for improvement of publications and blank forms. Additional blank sheets may be used if more space is needed.)

EXAMPLE

TYPED NAME, GRADE OR TITLE MSG, Jane Q. Doe, SFC	TELEPHONE EXCHANGE/AUTOVON, PLUS EXTENSION 788-1234	SIGNATURE
---	--	-----------

RECOMMENDED CHANGES TO PUBLICATIONS AND BLANK FORMS						Use Part II (reverse) for Repair Parts and Special Tool Lists (RPSTL) and Supply Catalogs/Supply Manuals (SC/SM)	DATE
<small>For use of this form, see AR 25-30; the proponent agency is ODISC4.</small>							
TO: (Forward to proponent of publication or form)(Include ZIP Code) Commander, U.S. Army Aviation and Missile Command ATTN: AMSAM-MMC-MA-NP Redstone Arsenal, AL 35898						FROM: (Activity and location)(Include ZIP Code)	
PART 1 - ALL PUBLICATIONS (EXCEPT RPSTL AND SC/SM) AND BLANK FORMS							
PUBLICATION/FORM NUMBER						DATE	TITLE
TM 1-1520-248-23-7						28 Feb 2000	AVIM/AVUM Maintenance Manual
ITEM NO.	PAGE NO.	PARA-GRAPH	LINE NO. *	FIGURE NO.	TABLE NO.	RECOMMENDED CHANGES AND REASON	
<small>* Reference to line numbers within the paragraph or subparagraph.</small>							
TYPED NAME, GRADE OR TITLE						TELEPHONE EXCHANGE/ AUTOVON, PLUS EXTENSION	SIGNATURE

TO: (Forward direct to addressee listed in publication) Commander, U.S. Army Aviation and Missile Command ATTN: AMSAM-MMC-MA-NP Redstone Arsenal, AL 35898	FROM: (Activity and location) (Include ZIP Code)	DATE
--	---	-------------

PART II - REPAIR PARTS AND SPECIAL TOOL LISTS AND SUPPLY CATALOGS/SUPPLY MANUALS

PUBLICATION NUMBER TM 1-1520-248-23-7	DATE 28 Feb 2000	TITLE AVIM/AVUM Maintenance Manual
---	----------------------------	--

PAGE NO.	COLM NO.	LINE NO.	NATIONAL STOCK NUMBER	REFERENCE NO.	FIGURE NO.	ITEM NO.	TOTAL NO. OF MAJOR ITEMS SUPPORTED	RECOMMENDED ACTION

PART III - REMARKS (Any general remarks or recommendations, or suggestions for improvement of publications and blank forms. Additional blank sheets may be used if more space is needed.)

TYPED NAME, GRADE OR TITLE	TELEPHONE EXCHANGE/AUTOVON, PLUS EXTENSION	SIGNATURE
----------------------------	--	-----------

The Metric System and Equivalents

Linear Measure

1 centimeter = 10 millimeters = .39 inch
 1 decimeter = 10 centimeters = 3.94 inches
 1 meter = 10 decimeters = 39.37 inches
 1 dekameter = 10 meters = 32.8 feet
 1 hectometer = 10 dekameters = 328.08 feet
 1 kilometer = 10 hectometers = 3,280.8 feet

Weights

1 centigram = 10 milligrams = .15 grain
 1 decigram = 10 centigrams = 1.54 grains
 1 gram = 10 decigrams = .035 ounce
 1 decagram = 10 grams = .35 ounce
 1 hectogram = 10 decagrams = 3.52 ounces
 1 kilogram = 10 hectograms = 2.2 pounds
 1 quintal = 100 kilograms = 220.46 pounds
 1 metric ton = 10 quintals = 1.1 short tons

Liquid Measure

1 centiliter = 10 milliliters = .34 fl. ounce
 1 deciliter = 10 centiliters = 3.38 fl. ounces
 1 liter = 10 deciliters = 33.81 fl. ounces
 1 dekaliter = 10 liters = 2.64 gallons
 1 hectoliter = 10 dekaliters = 26.42 gallons
 1 kiloliter = 10 hectoliters = 264.18 gallons

Square Measure

1 sq. centimeter = 100 sq. millimeters = .155 sq. inch
 1 sq. decimeter = 100 sq. centimeters = 15.5 sq. inches
 1 sq. meter (centare) = 100 sq. decimeters = 10.76 sq. feet
 1 sq. dekameter (are) = 100 sq. meters = 1,076.4 sq. feet
 1 sq. hectometer (hectare) = 100 sq. dekameters = 2.47 acres
 1 sq. kilometer = 100 sq. hectometers = .386 sq. mile

Cubic Measure

1 cu. centimeter = 1000 cu. millimeters = .06 cu. inch
 1 cu. decimeter = 1000 cu. centimeters = 61.02 cu. inches
 1 cu. meter = 1000 cu. decimeters = 35.31 cu. feet

Approximate Conversion Factors

To change	To	Multiply by	To change	To	Multiply by
inches	centimeters	2.540	ounce-inches	Newton-meters	.007062
feet	meters	.305	centimeters	inches	.394
yards	meters	.914	meters	feet	3.280
miles	kilometers	1.609	meters	yards	1.094
square inches	square centimeters	6.451	kilometers	miles	.621
square feet	square meters	.093	square centimeters	square inches	.155
square yards	square meters	.836	square meters	square feet	10.764
square miles	square kilometers	2.590	square meters	square yards	1.196
acres	square hectometers	.405	square kilometers	square miles	.386
cubic feet	cubic meters	.028	square hectometers	acres	2.471
cubic yards	cubic meters	.765	cubic meters	cubic feet	35.315
fluid ounces	milliliters	29.573	cubic meters	cubic yards	1.308
pints	liters	.473	milliliters	fluid ounces	.034
quarts	liters	.946	liters	pints	2.113
gallons	liters	3.785	liters	quarts	1.057
ounces	grams	28.349	liters	gallons	.264
pounds	kilograms	.454	grams	ounces	.035
short tons	metric tons	.907	kilograms	pounds	2.205
pound-feet	Newton-meters	1.356	metric tons	short tons	1.102
pound-inches	Newton-meters	.11296			

Temperature (Exact)

F	Fahrenheit temperature	5/9 (after subtracting 32)	Celsius temperature	C
---	---------------------------	-------------------------------	------------------------	---

This fine document...

Was brought to you by me:



[Liberated Manuals -- free army and government manuals](#)

Why do I do it? I am tired of sleazy CD-ROM sellers, who take publicly available information, slap “watermarks” and other junk on it, and sell it. Those masters of search engine manipulation make sure that their sites that sell free information, come up first in search engines. They did not create it... They did not even scan it... Why should they get your money? Why are not letting you give those free manuals to your friends?

I am setting this document FREE. This document was made by the US Government and is NOT protected by Copyright. Feel free to share, republish, sell and so on.

I am not asking you for donations, fees or handouts. If you can, please provide a link to liberatedmanuals.com, so that free manuals come up first in search engines:

<A HREF=<http://www.liberatedmanuals.com/>>Free Military and Government Manuals

– Sincerely
Igor Chudov
<http://igor.chudov.com/>