

BLM LIBRARY



88055278

FINAL REPORT
BASELINE METEOROLOGY AND AIR QUALITY
IN THE SUSANVILLE DISTRICT



SCIENCE APPLICATIONS, INC.
ENVIRONMENTAL SCIENCE AND TECHNOLOGY



#56494



May 30, 1980



State Director
Bureau of Land Management
California State Office
2800 Cottage Way
Sacramento, CA 95825

Attention: Ms. Lois Payne

Subject: Contract #YA-512-CT7-26/Task Order #YA-510-PH7-114
Final Susanville District Report

Dear Ms. Payne:

Enclosed herewith are five copies of the Final Susanville District Report with appropriate overlays. The preparation of this document represents the completion of Task Item XVII in our negotiated work statement dated 9 October 1979. You may expect to receive the Final Redding District Report next week and the Final Bakersfield District Report will follow when comments are received from you and the District office.

SA
L
E

F 56496426

ID 88055278

CALIFORNIA STATE OFFICE
CENTRAL LIBRARY COPY

QC
882
.5873
1980
v.1

FINAL REPORT
 BASELINE METEOROLOGY AND AIR QUALITY
 IN THE SUSANVILLE DISTRICT

Submitted to:

Bureau of Land Management
Sacramento, California

Prepared by:

D. Rykaczewski

May 30, 1980

BLM Library
Bldg. 50
Denver Federal Center
P.O. Box 25047
Denver, Colorado 80225



SCIENCE APPLICATIONS, INC.

LA JOLLA, CALIFORNIA - P.O. Box 2351, 1200 Prospect Street, La Jolla, CA 92038 (714) 454-3811

ENVIRONMENTAL SCIENCE AND TECHNOLOGY



[Faint, illegible text covering the upper half of the page]

[Faint, illegible text in the middle of the page]

[Faint, illegible text covering the lower half of the page]



TABLE OF CONTENTS

<u>Section</u>		<u>Page</u>
1	INTRODUCTION	1
2	PHYSICAL FEATURES	7
3	CLIMATOLOGY	13
	3.1 Principles of Climatology	13
	3.2 Climatic Zones	25
	3.3 Sources of Climatological Data	28
	3.3.1 Observations and Records	28
	3.4 Temperature	33
	3.4.1 Mean Temperature Distribution	35
	3.4.2 Temperature Extremes	39
	3.4.3 Frost-Free Period	41
	3.5 Precipitation	44
	3.5.1 Annual Distribution	44
	3.5.2 Seasonal Precipitation	47
	3.5.3 Snowfall	48
	3.5.4 Precipitation Frequency	48
	3.6 Prevailing Winds	55
	3.6.1 Annual Wind Distribution	55
	3.6.2 Seasonal Wind Distribution	59
	3.7 Evaporation and Related Parameters	63
	3.7.1 Evaporation and Evapotranspiration	63
	3.7.2 Sky Conditions	67
	3.7.3 Solar Radiation	75
	3.8 Other Climatic Parameters	78
	3.8.1 Relative Humidity and Dew Point	78
	3.8.2 Severe Weather	79
	3.8.3 Atmospheric Pressure	92
	3.8.4 Visibility and Fog	94
	3.9 Urban Effect Upon Meteorological Parameters	105
	3.10 General Assistance in Climatic Problems	109
	3.11 Glossary of Terms	115
4	DISPERSION METEOROLOGY	126
	4.1 Introduction	126
	4.2 Principles of Dispersion Meteorology	128
	4.2.1 Principles of Turbulence and Diffusion	128
	4.2.2 Prevailing Winds	134
	4.2.3 Atmospheric Stability	141
	4.2.4 Mixing Heights and Inversions	150

TABLE OF CONTENTS (CONTINUED)

<u>Section</u>		<u>Page</u>
4.3	Data Sources	163
4.4	Prevailing Winds.	165
	4.4.1 Wind Roses	165
	4.4.2 Diurnal Wind Distribution	177
	4.4.3 Wind Speed Distribution	178
	4.4.4 Persistence Analyses	186
	4.4.5 Trajectory Analyses	188
	4.4.6 Winds Aloft	188
4.5	Atmospheric Stability	193
	4.5.1 Seasonal and Annual Stability Distributions	193
	4.5.2 Diurnal Stability Distributions	200
	4.5.3 Stability Persistence	205
	4.5.4 Stability Wind Roses	207
4.6	Mixing Heights and Inversions	212
	4.6.1 Mixing Height	212
	4.6.2 Inversion Types and Frequencies	219
4.7	Typical and Worst-Case Conditions	222
	4.7.1 Typical Dispersion Conditions	222
	4.7.2 Worst-Case Dispersion Conditions	222
4.8	Air Basin Analysis.	227
4.9	Fire Weather.	232
4.10	General Dispersion Modeling	239
	4.10.1 Classes of Models	239
	4.10.2 Model Suitability and Application	240
	4.10.3 The Gaussian Model	242
4.11	Assistance in Dispersion Meteorological Problems	270
4.12	Glossary of Terms	272
5	BASELINE AIR QUALITY EMISSION LEVELS	285
5.1	Formation of Air Pollutants	285
	5.1.1 Introduction.	285
	5.1.2 The Gaseous Compounds of Carbon	285
	5.1.2.1 The Hydrocarbons	291
	5.1.2.2 The Oxygenated Hydrocarbons	291
	5.1.2.3 The Oxides of Carbon	296
	5.1.3 The Gaseous Compounds of Sulfur	305
	5.1.3.1 The Sulfur Oxides	305
	5.1.3.2 Reduced Sulfur Compounds	308
	5.1.4 The Gaseous Compounds of Nitrogen	310
	5.1.4.1 The Oxides of Nitrogen	310
	5.1.5 Ozone and Oxidants.	317
	5.1.6 Particulate Matter	319
	5.1.7 Atmospheric Chemistry of Air Pollution	322

TABLE OF CONTENTS (CONTINUED)

<u>Section</u>	<u>Page</u>
5.2	Air Pollution Effects on Air Quality Related Values 328
5.3	Baseline Ambient Air Quality 353
5.4	Point and Area Sources in the Susanville District 363
5.5	Assistance in Air Pollution Problems 372
5.6	Glossary of Terms 379
6	AIR QUALITY REGULATIONS 395
6.1	Executive Summary 395
6.1.1	Background 395
6.1.2	Permit Rules for New or Modified Sources 396
6.1.2.1	Nonattainment Areas 396
6.1.2.2	Attainment Areas and Prevention of Significant Deterioration Review. 396
6.1.2.3	Role of the Federal Land Manager in the Permit Review Process 397
6.1.2.4	Role of the Federal Land Manager in Class Redesignation Procedures. 399
6.1.3	Visibility Protection 399
6.1.4	Emission Standards 400
6.1.5	Permit Rules. 400
6.1.5.1	Permit Rules 400
6.2	The Role of the Federal Land Manager 401
6.3	History of Air Quality Legislation 403
6.4	Summary of the Clean Air Act Amendments of 1977, and Related Regulations 406
6.4.1	National Ambient Air Quality Standards (NAAQS). 406
6.4.2	Designation of Attainment Status 406
6.4.3	State Implementation Plans 407
6.4.3.1	Nonattainment Areas 407
6.4.3.2	Attainment Areas 408
6.4.4	Visibility Protection 420
6.4.5	Ozone Protection 422
6.5	State and County Regulations 423
6.5.1	State Ambient Air Quality Standards 423
6.5.2	County Regulations 423
6.5.3	Permit Rules 423
6.5.3.1	Description of Model Rule/Districts' Rule 426
6.5.3.2	California's Air Conservation Program (ACP) 427
6.5.3.3	Emission Regulation 428
6.6	Glossary of Terms 434

TABLE OF CONTENTS (CONTINUED)

<u>Section</u>		<u>Page</u>
7	MONITORING RECOMMENDATIONS.	439
7.1	General Requirements	439
7.2	Instrumentation	442
	7.2.1 General Requirements	442
	7.2.2 Meteorological Instruments.	445
	7.2.3 Air Quality Instruments	457
	7.2.3.1 Particulates	457
	7.2.3.2 Continuous Gas Analyzers	462
	7.2.4 Monitoring Program Operation	467
7.3	Susanville District Monitoring Requirements	477
7.4	Glossary of Terms	480

1. INTRODUCTION

This document provides baseline data on meteorology and air quality impacting BLM lands in California, and specifically, in the Susanville District. Air quality considerations have become important factors in the establishment and execution of Federal land management policies. As with any resource, an assessment of current air quality and meteorological data must be performed to determine the present environmental baseline conditions.

BLM manages approximately 16.5 million acres in California as depicted in Figure 1-1. Figure 1-2 depicts BLM administered lands in the Susanville District. Figure 1-2 is also provided as Overlay A. In addition, gridded township and range locations for the Susanville District are provided on Figure 1-3. This map can be used directly with the color coded overlays provided for key parameters.

The purpose of this document is to provide information which can be used with other resource information to facilitate land use planning decisions for the Susanville District.

The specific objectives of this work effort include the following:

- o Describe the climatology, dispersion meteorology and air quality in the Susanville District utilizing available historical data.
- o Assess the emission sources which influence all BLM land areas in the Susanville District.
- o Assess past and present air quality and meteorological monitoring activities and provide monitoring recommendations for the Susanville District.
- o Provide a complete bibliography of available information and a glossary of all technical terms.

The above provides a brief synopsis of the objectives of this report. The document is intended for use by BLM personnel in all activities involved in the management of BLM administered lands.

This document uses a graphics intensive approach in the presentation of the meteorological and air quality baseline for BLM lands in the Susanville District. The data base which has been used to develop this document comprises that available in published form from governmental, academic, and private institutions within the state. These sources of data are summarized in the appropriate sections for dispersion meteorology, climatology, air quality, and emissions.

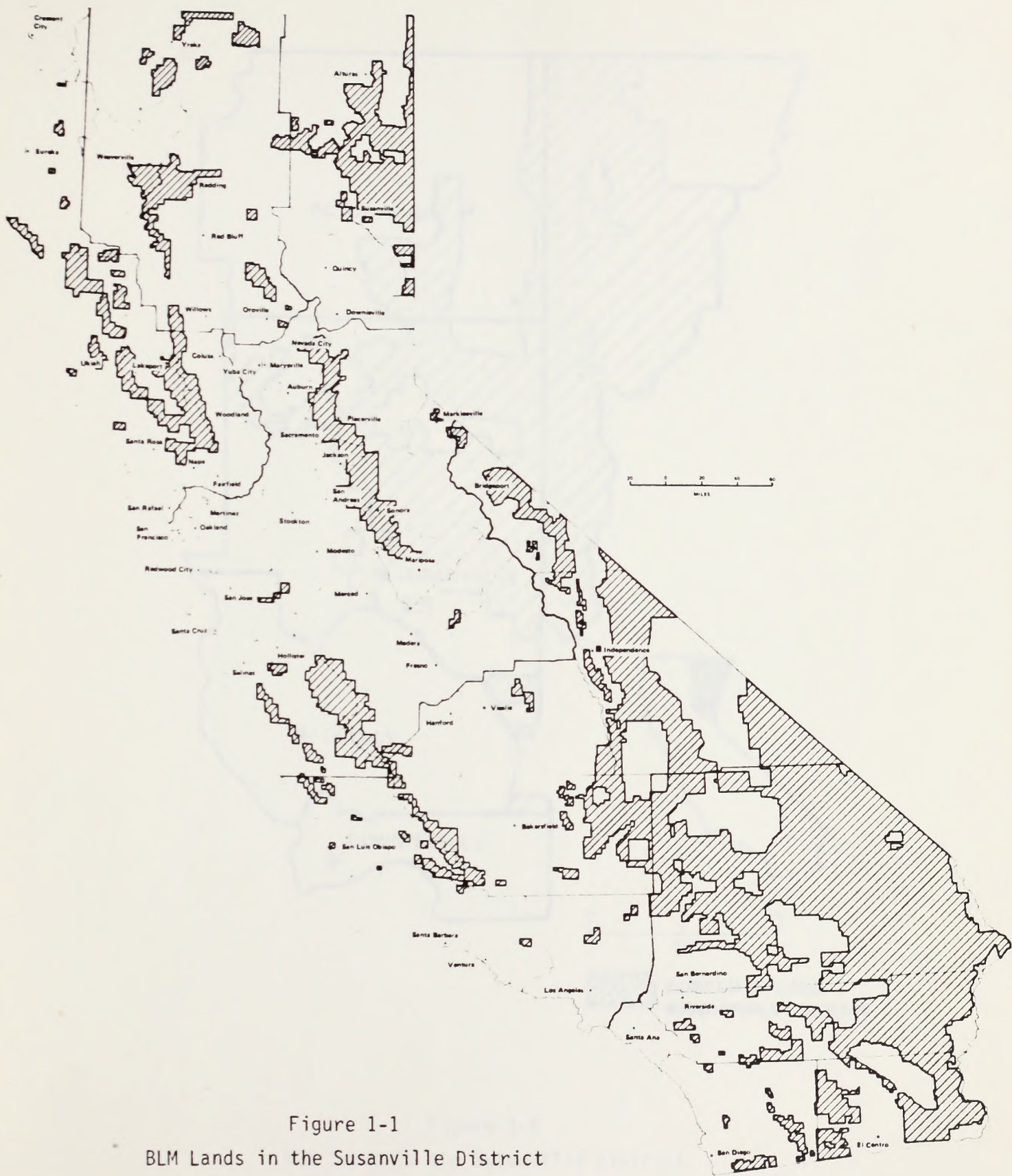

Figure 1-1
 BLM Lands in the Susanville District
 and the State of California

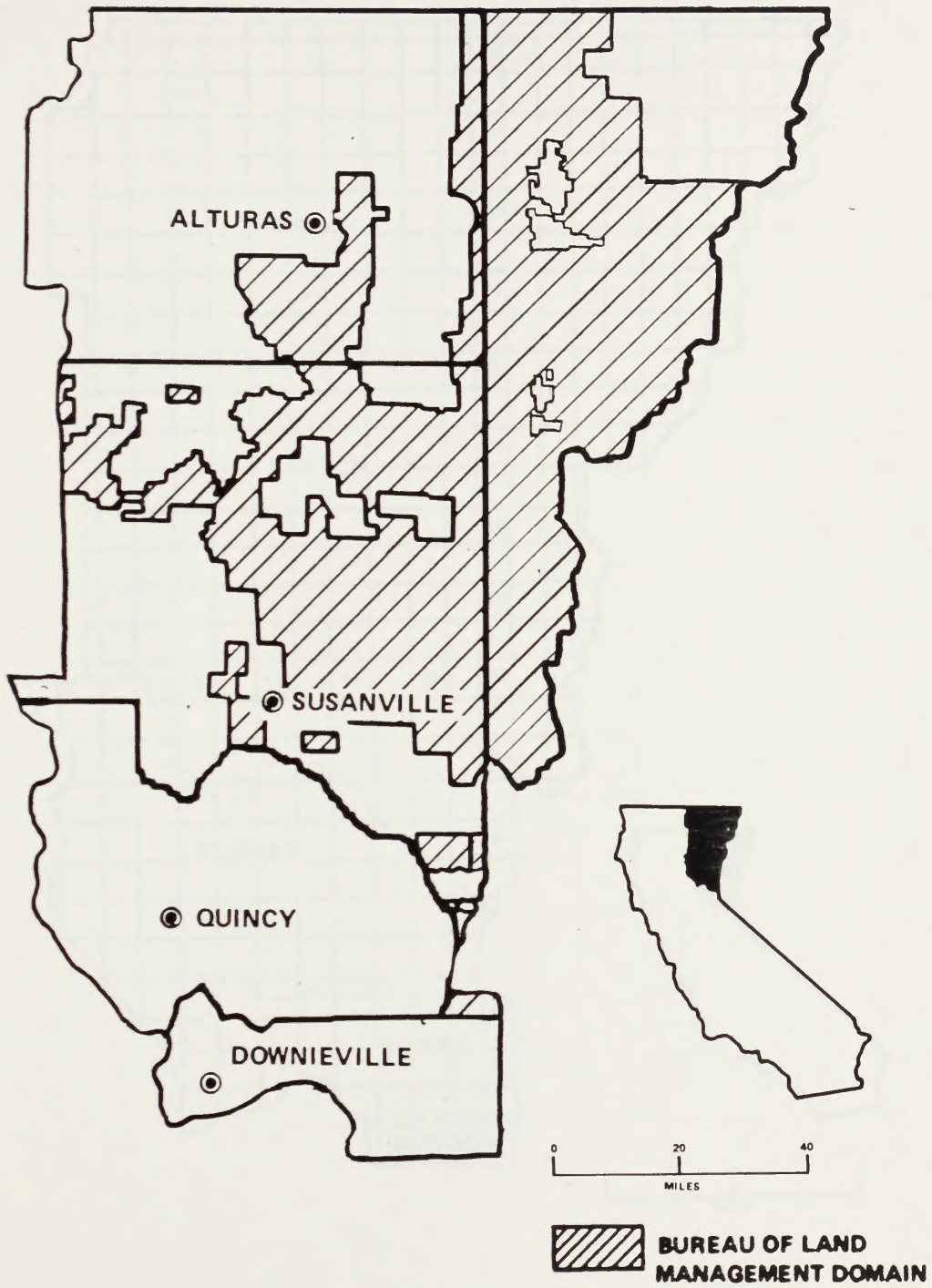

Figure 1-2
BLM Lands in the Susanville District

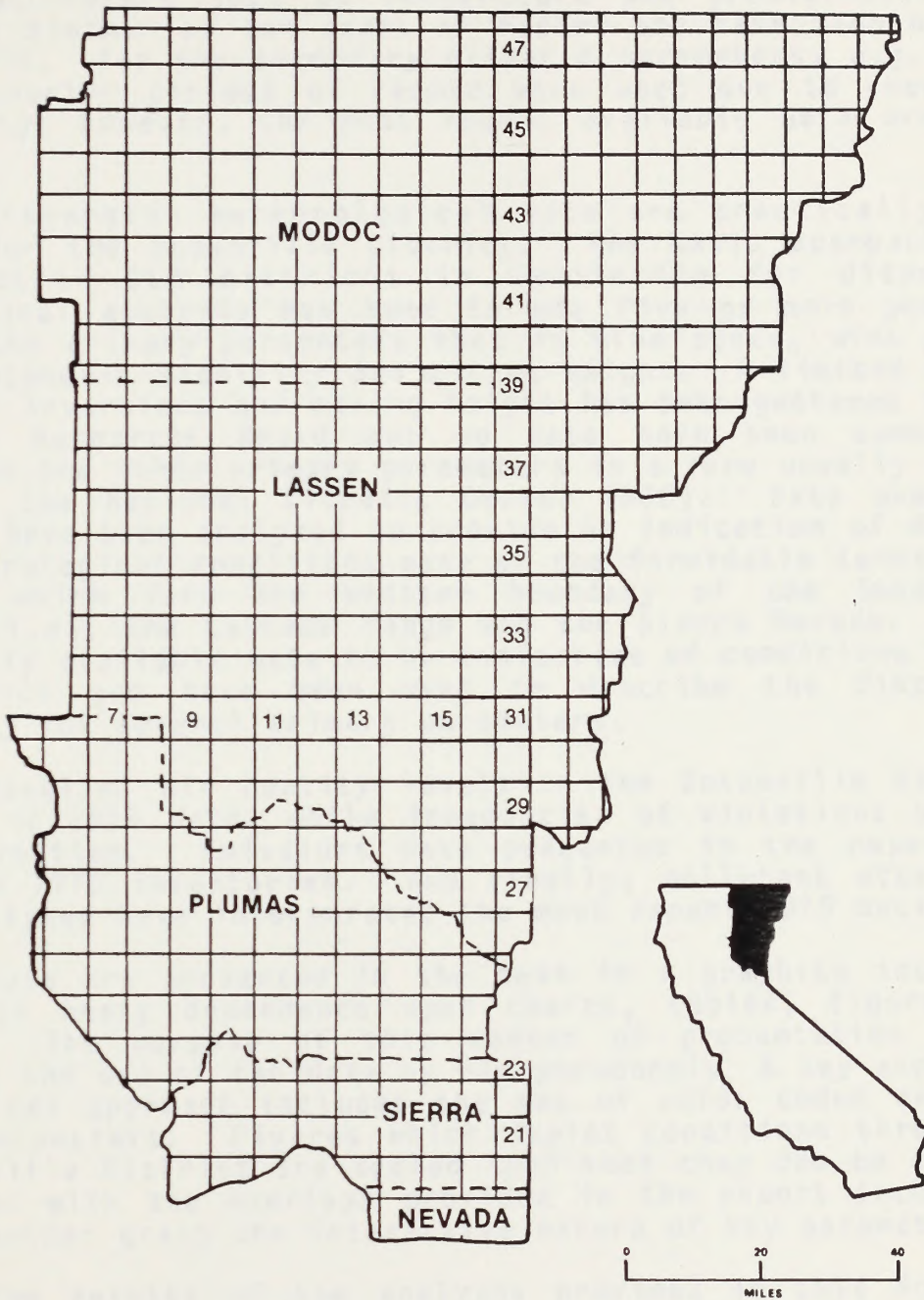

Figure 1-3
 Gridded Township (N-S) and Range (E-W)
 Locations in the Susanville District

The report presents data which represent meaningful (i.e., long-term) and representative time periods. The primary climatic parameters such as temperature and precipitation are based on a minimum of ten years of record and have been updated through 1976. For the secondary climatic parameters, e.g. evaporation, shorter periods of record were used due to poor data availability; however, the most recent available data are presented.

Dispersion meteorological data are practically non-existent for the Susanville District. The basic approach used for the other BLM districts in California for dispersion meteorological analysis has been to use five or more years of data for the primary parameters that is wind speed, wind direction, atmospheric stability and mixing height. A limited number of data on inversions and mixing height has been gathered by the California Resources Board but no data have been summarized relative to the other primary parameters in a form usually available from the National Climatic Center (NCC). Data available from Reno have been analyzed to provide an indication of dispersion meteorological conditions east of the formidable terrain and obstacles which form the western boundary of the Susanville District, i.e., the Cascade Range and the Sierra Nevada. These are the only available data to be indicative of conditions within the District and have been used to describe the dispersion meteorology for several primary parameters.

Baseline air quality levels in the Susanville District are based on 1975 data, while frequencies of violations utilize 1977 information. Emissions data presented in the report are based upon 1976 inventories. And finally, pollutant attainment status analyses have incorporated the most recent 1979 decisions.

Data are presented in the text in a graphics intensive manner with heavy dependence upon charts, tables, figures and overlays. The purpose of this manner of presentation is to facilitate the use of the data by blm personnel. A key aspect of the graphical approach includes the use of color coded overlays for key parameters. Figures which depict conditions throughout the Susanville District are scaled such that they can be used in conjunction with the overlays provided in the report jacket, in order to better grasp the interactive nature of key parameters.

The results of the analyses provided in this document can be used by BLM personnel for a multitude of applications. The document has been written in straightforward and simplistic language such that it can be used by all levels of BLM technical personnel. A sufficient review of basic principles has been provided throughout the text such that it can also be used as a handbook for training purposes. It provides an excellent base for making a first cut analysis for specific air quality and climatological problems. In addition, the information contained in this document is suitable for use in the development of Environmental Statement sections. Some of the data provides back-

ground information suitable for the environmental setting and impact sections. However, the reader is cautioned that a detailed analysis of major problem areas, such as the potential impact of new pollutant sources, would require additional analysis and analytical review beyond that contained in this document.

Finally, in addition to its uses as a training handbook and for use in Environmental Statements, this document can be used for overall planning purposes by BLM land managers. This is one of the major intents for publishing the document. It is felt that the information contained herein will provide suitable information on which one can base judgments relative to the optimum utilization of BLM lands in terms of such potential alternatives as agriculture, forest management and energy development, as these relate to the air resource.

This report is intended as an environmental baseline document suitable for use in the administration of BLM lands. Recommendations have been provided in the text concerning the need for additional data to adequately describe the environmental baseline, i.e., air quality and meteorology in certain portions of the Susanville District. Monitoring would be required, as well as additional analyses, prior to making final decisions relative to major potential sources of air pollutants on BLM lands. Recommendations contained in this document for additional data collection and for additional analyses must be seriously considered by BLM planners during any final decision-making process. In addition, the information contained herein is current as of the publication date, but care must be taken while using the document, to ensure that all information and materials are up to date, particularly with regard to air quality regulations. For this reason, it is recommended that this document be updated on an annual basis by qualified technical personnel.

Separate reports have also been prepared for the Ukiah, Redding, Riverside, Bakersfield and Folsom Districts. Reference should be made to the appropriate reports for air quality and meteorological baseline conditions for BLM lands outside of the Susanville District in California.

2. PHYSICAL FEATURES

The following discussion provides a review of the major terrain and vegetation features in the Susanville District. Susanville is comprised of numerous terrain and vegetation types as indicated in the accompanying figures. Elevations range from less than 3000 feet in the western slopes of the Sierra Nevada to near 10,000 feet in the Modoc National Forest. Vegetation types range from pines to sagebrush and chaparral.

The major vegetation types as classified by Durrenberger (1967) are depicted in Figure 2-1. This figure, illustrates the variety of vegetation types found in the interior mountainous regions. Vegetation types range from pine, Douglas, fir, Lodgepole and Whitebark Pine in the Cascade Range and the Sierra Nevada, to sagebrush and chaparral in the northeastern plateau. The vegetation change reflects the increase in dryness with progression to the east of the Susanville District.

As indicated earlier, these vegetation types are distinctly influenced by terrain considerations. Figure 2-2 provides a review of major terrain features in the State of California. Figure 2-3 illustrates the Susanville District terrain. This figure is also included as Overlay B.

The Susanville District includes all or portions of Modoc, Lassen, Plumas and Sierra Counties in California and Washoe and Humboldt Counties in Nevada. The terrain of the District is comprised by high plateau interspersed with mountain ranges with elevations generally in excess of 3,000 feet. The Cascade Range and the Sierra Nevada comprise the western boundaries of the Susanville District, while to the east the District lies largely open to the Great Basin of the United States. The District is generally characterized by dry terrain east of the Cascade Range and the Sierra Nevada and is characterized by dry lake beds at lower elevations and many existing lakes in the mountainous regions.

The southwestern portion of the District is mountainous lying within the Sierra Nevada range. The region is cut by many river valleys along the western foothills of the Sierra Nevada. These include the Feather River in Plumas County and just to the south of the District the Yuba River in Nevada County. Locally, the rugged terrain in this area is referred to as the Grizzly Mountains with elevations generally between 6,000 and 8,000 feet. Babbit Peak in the extreme southwest reaches an elevation of 8,760 feet. The area is also cut by river valleys and towns like Quincy, Greenville, Chester and Susanville are generally at elevations of less than 5,000 feet and in some cases less than 4,000 feet. Lake Almanor and Eagle Lake are the largest bodies of standing water in this region. Further to the north in the California portion of the Susanville District, the terrain is fairly rugged and increasingly dry with its progression to the



Figure 2-1
Major Vegetation Types
in California

Source: "Patterns on the Land" Robert W. Durrenberger

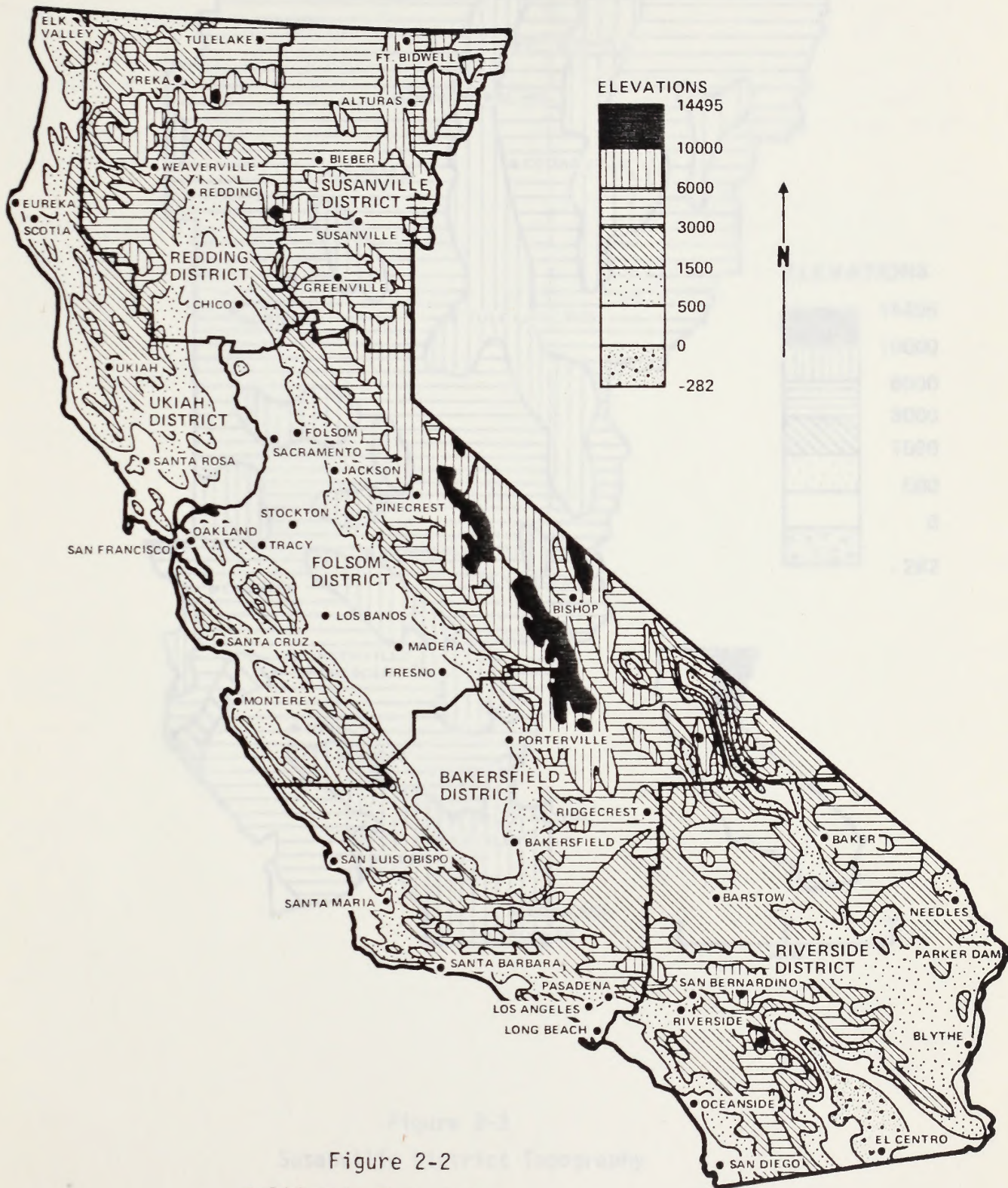

Figure 2-2
California Topography

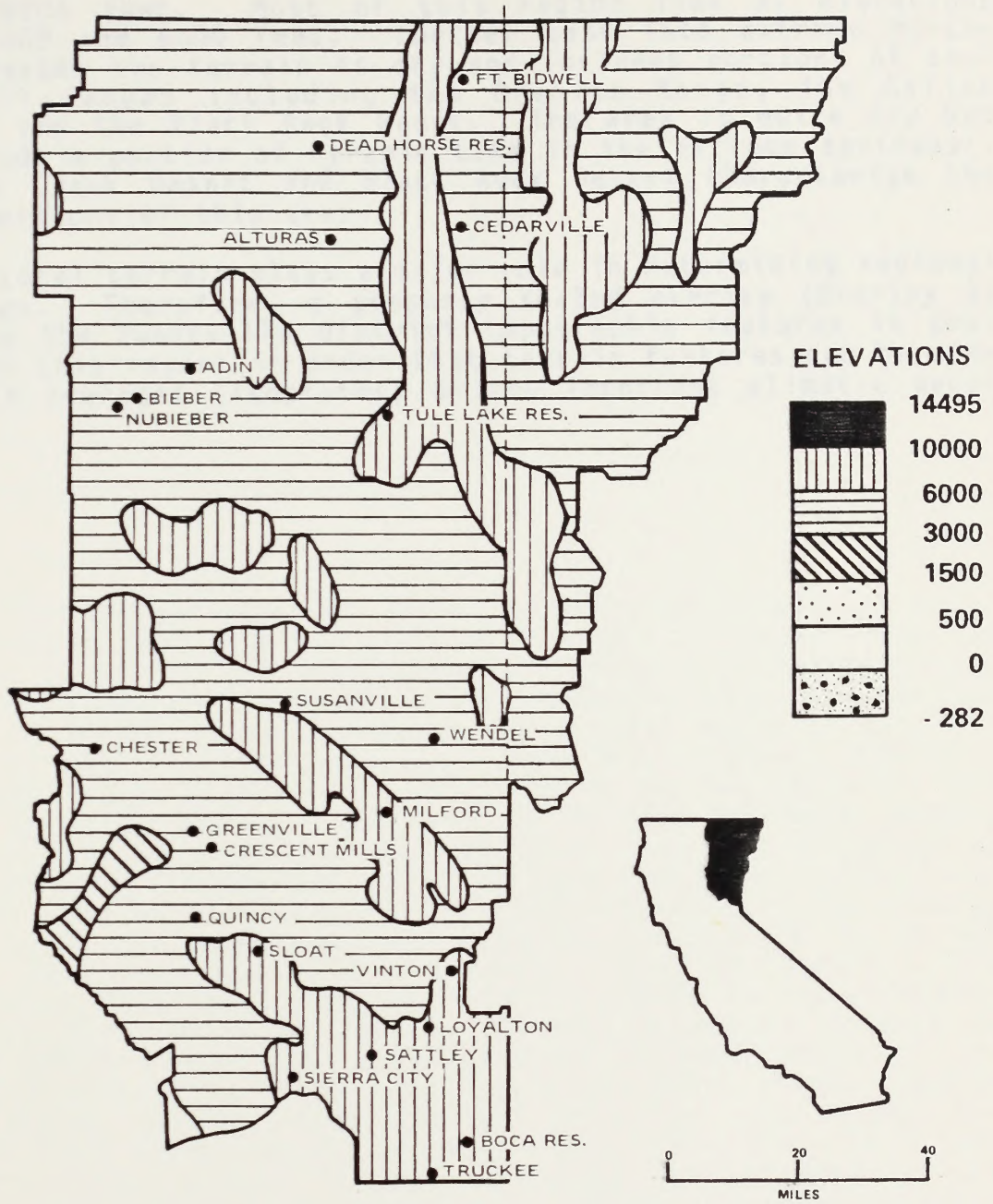

Figure 2-3
Susanville District Topography

north and east. The highest point in the Susanville District is located in the Modoc National Forest at Eagle Peak at an elevation of 9906 feet. Most of this region lies at elevations between 4000 and 6000 feet. Further east into extreme northwestern Nevada the terrain is dry and includes portions of several small ranges including the Granite Range, The Calico Mountains and the Black Rock Range. The area is quite dry but does include a portion of Pyramid Lake in the extreme southwest. The Smoke Creek Desert and Black Rock Desert characterize the eastern portions of this area.

Local terrain plays a major role in determining regional climatology. Therefore, a properly scaled overlay (Overlay B) displaying the Susanville District topographic features is provided with this report in order that terrain features can be compared with averages (isopleths) of the important climatic parameters.

3.1 FACTORS OF CLIMATOLOGY

3.1.1 Energy

The energy provided by solar radiation is primarily derived from the sun. This transfer of energy from the sun to the earth and the atmosphere is the result of radiational heat by electromagnetic waves. The radiation from the sun has the full spectrum of wavelengths, but the visible range (0.4 to 0.7 microns) of the electromagnetic spectrum has relatively low energy in the infrared and ultraviolet regions as well. The greatest part of the sun's energy is emitted at wave lengths between 0.4 and 0.7 microns. Some of this radiation is reflected from the tops of clouds and from the land and water surfaces of the earth. The general term for this reflection is the albedo. For the earth and atmosphere as a whole, the albedo is 0.30 or 30 percent for mean conditions of cloudiness over the earth. This reflectivity is due to the white color of water clouds, and light scattering by particles through a volume containing particles whose diameter is smaller than the wave length of the light, scattering of a portion of this light takes place. Shorter wavelength scatter most easily, which is the reason the scattered light from the sky appears blue. Scattering near sunset and sunrise, passes through a greater path-length of the atmosphere and appears more red because of the increased scattering of shorter wave lengths. Scattering of solar radiation by some of the gases in the atmosphere (mainly water vapor) also takes place. Water vapor, although comprising only 1 percent of the atmosphere, is the average absorber about 75 percent of the solar radiation as all other gases combined. Consequently, the amount of radiation received at the earth's surface is considerably less than that received above the atmosphere.

The earth also radiates energy in proportion to its temperature according to Wien's law. Because of the earth's temperature, the maximum emission is about 10 microns, which is

BIBLIOGRAPHY

1. Durrenberger, Robert W., Patterns on the Land, National Press Books, Palo Alto, California, Second Printing, 1967.

3. CLIMATOLOGY

This section is designed to characterize the prevailing climate of the Susanville District as well as to describe the physical processes that determine regional climate. Long-term manifestations of weather are best described by regional and local analyses of the numerous climatic parameters, i.e., temperature, precipitation, winds, evaporation and evapotranspiration, sky conditions, dew point and humidity, pressure distributions, severe weather and many others. The following sections shall describe the various climatic statistics pertinent to the area.

Color coded overlays for selected key climatic summaries are provided to facilitate the correlation of the primary climatic variables in particular geographic areas. Much of the enclosed graphical material is properly scaled to the overlay dimensions.

3.1 PRINCIPLES OF CLIMATOLOGY

Energy

The energy expended in atmospheric processes is originally derived from the sun. This transfer of energy from the sun to the earth and its atmosphere is the result of radiational heat by electromagnetic waves. The radiation from the sun has its peak of energy transmission in the visible range (0.4 to 0.7 microns) of the electromagnetic spectrum but releases considerable energy in the ultraviolet and infrared regions as well. The greatest part of the sun's energy is emitted at wave lengths between 0.1 and 30 microns. Some of this radiation is reflected from the tops of clouds and from the land and water surfaces of the earth. The general term for this reflectivity is the albedo. For the earth and atmosphere as a whole, the albedo is 36 per cent for mean conditions of cloudiness over the earth. This reflectivity is greatest in the visible range of wavelengths. When light (or radiation) passes through a volume containing particles whose diameter is smaller than the wavelength of the light, scattering of a portion of this light takes place. Shorter wavelengths scatter most easily, which is the reason the scattered light from the sky appears blue. Sunlight, near sunrise and sunset, passes through a greater path-length of the atmosphere and appears more red because of the increased scattering of shorter wave lengths. Absorption of solar radiation by some of the gases in the atmosphere (notably water vapor) also takes place. Water vapor, although comprising only 3 per cent of the atmosphere, on the average absorbs about six times as much solar radiation as all other gases combined. Consequently, the amount of radiation received at the earth's surface is considerably less than that received above the atmosphere.

The earth also radiates energy in proportion to its temperature according to Planck's law. Because of the earth's temperature, the maximum emission is about 10 microns, which is

in the infrared region of the spectrum. The gases of the atmosphere absorb some wave length regions of this radiation. Water vapor absorbs strongly between 5.5 and 7 microns and at greater than 27 microns but is essentially transparent from 8 to 13 microns. Carbon dioxide absorbs strongly between 13 and 17.5 microns. Because the atmosphere absorbs much more of the terrestrial radiation than solar radiation, some of the heat energy of the earth is conserved. This is the "greenhouse" effect.

Figure 3.1-1 shows the amount of solar radiation absorbed by the earth and atmosphere compared to the long wave radiation leaving the atmosphere as a function of latitude. The sine of the latitude is used as the abscissa to represent area. It can be seen that if there were no transfer of heat poleward, the equatorial regions would continue to gain heat and the polar regions would continue to cool. However, temperatures do remain nearly constant because of this poleward transfer of heat. The required transfer of heat across various latitudes is given in Table 3.1-1.

Table 3.1-1
Required Flux of Heat Toward the
Poles Across Latitudes (10^{19} calories per day) (1)

Latitude(°)	Flux
0	0
10	4.05
20	7.68
30	10.46
40	11.12
50	9.61
60	6.68
70	3.41
80	0.94
90	0

1. Source: H. G. Houghton, "On the Annual Heat Balance of the Northern Hemisphere."

The General Circulation

The previous section has indicated the necessity of transfer of heat from the warm equatorial regions to the cold polar regions in order to maintain the heat balance of the atmosphere. This thermal driving force is the main cause of atmospheric motion on the earth. The portion of the earth near the equator acts as a heat source and the polar regions as a heat sink. The atmosphere functions as a heat engine transforming the potential energy of heat difference between tropics and poles to kinetic energy of motion which transports heat poleward from source to sink.

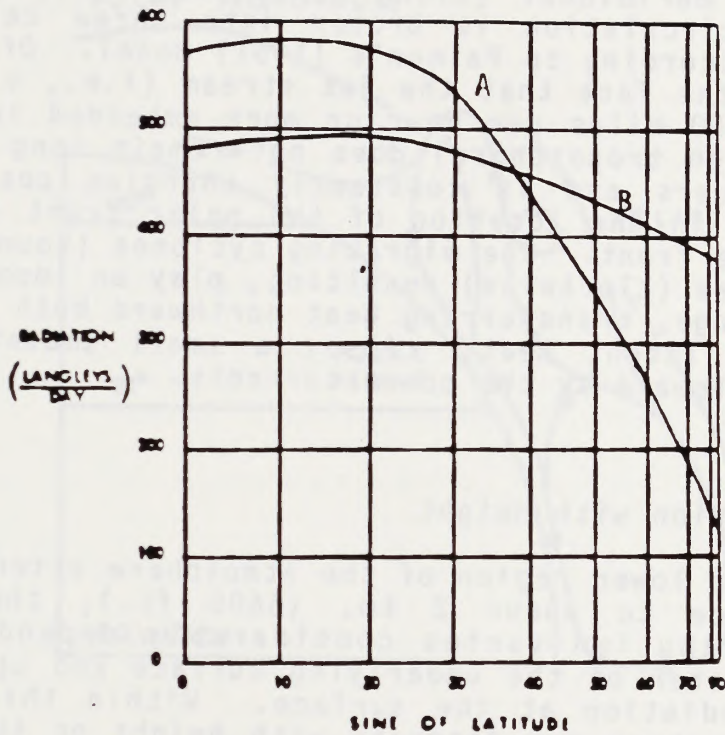

- A Solar Radiation Absorbed by Earth and Atmosphere
- B Long Wave Radiation Leaving the Atmosphere

Figure 3.1-1
Global Radiation Balance

If the earth did not rotate, rising air above the equator would move poleward continually giving up some of its heat until the time it would sink and return toward the equator as a surface current. Since the earth does rotate, the Coriolis force deflects winds in the northern hemisphere to the right. Therefore flow from the tropics toward the poles become more westerly and flow from the poles toward the equator tends to become easterly. The result is that more of the motion is around the earth (zonal) with less than one-tenth of the motion between poles and equator. The meridional (along meridians, i.e., between poles and equator) circulation is broken into three cells shown in Figure 3.1-2 according to Palmen's (1951) model. Of considerable importance is the fact that the jet stream (i.e., a core of high winds usually 50 miles per hour or more embedded in the westerlies in the high troposphere) does not remain long in one position but meanders and is constantly changing position. This causes changes in the location of the polar front and perturbations along the front. The migrating cyclones (counterclockwise) and anticyclones (clockwise) resulting, play an important part in the heat exchange, transferring heat northward both as a sensible heat and also latent heat. Also, a small amount of heat is transferred poleward by the ocean currents.

Temperature

o Variation with Height

In the lower region of the atmosphere extending from the surface to about 2 km. (6600 ft.), the temperature distribution varies considerably depending upon the character of the underlying surface and upon the amount of radiation at the surface. Within this region, the temperature may decrease with height or it may actually increase with height (inversion). This region, commonly called the lower troposphere, is the region of greatest interest in air pollution meteorology. The remainder of the troposphere is typified by a decrease of temperature with height on the order of 4 to 8°C per km. The stratosphere is a region with isothermal or slight inversion lapse rates. The layer of transition between the troposphere and stratosphere is called the tropopause. The tropopause varies in height from about 8 to 20 km (26,000 to 66,000 ft.), and is highest near the equator, lowest near the poles. Figure 3.1-3 and 3.1-4 indicate typical temperature variations with height for two latitudes for summer and winter in the troposphere and lower stratosphere.

Above the stratosphere, the high atmosphere has several layers of differing characteristics. A rough indication of the variation of temperature with height including the high atmosphere is shown in Figure 3.1-5.

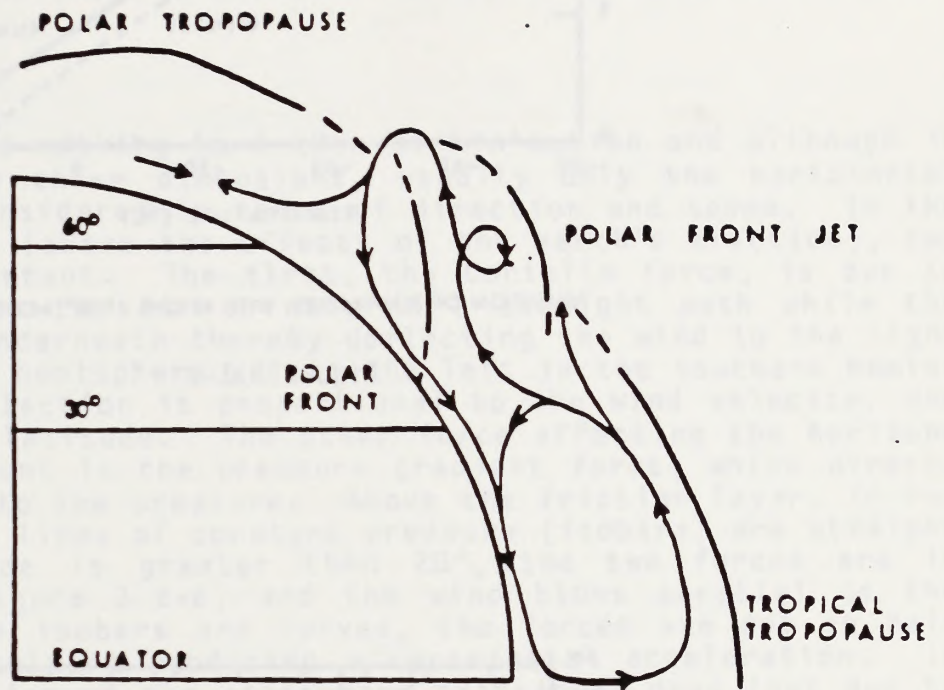
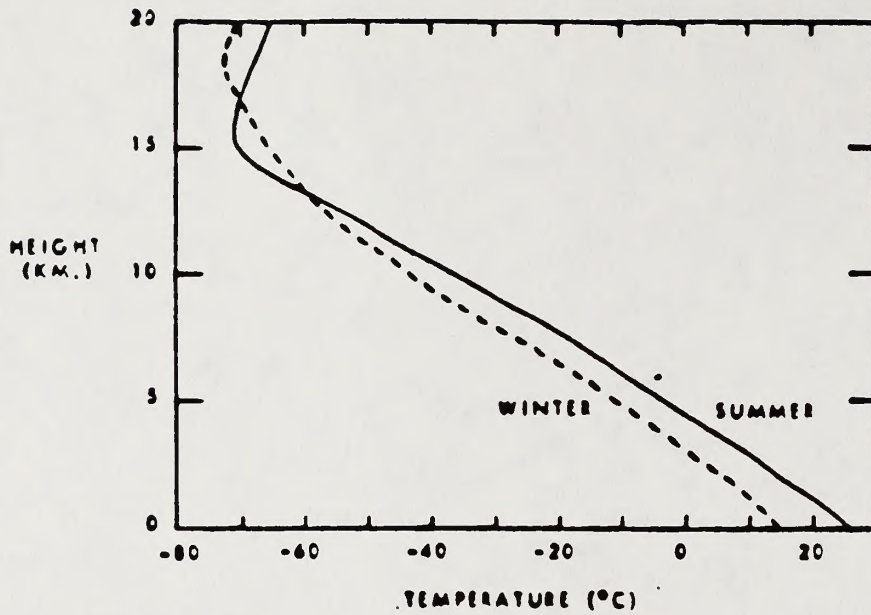
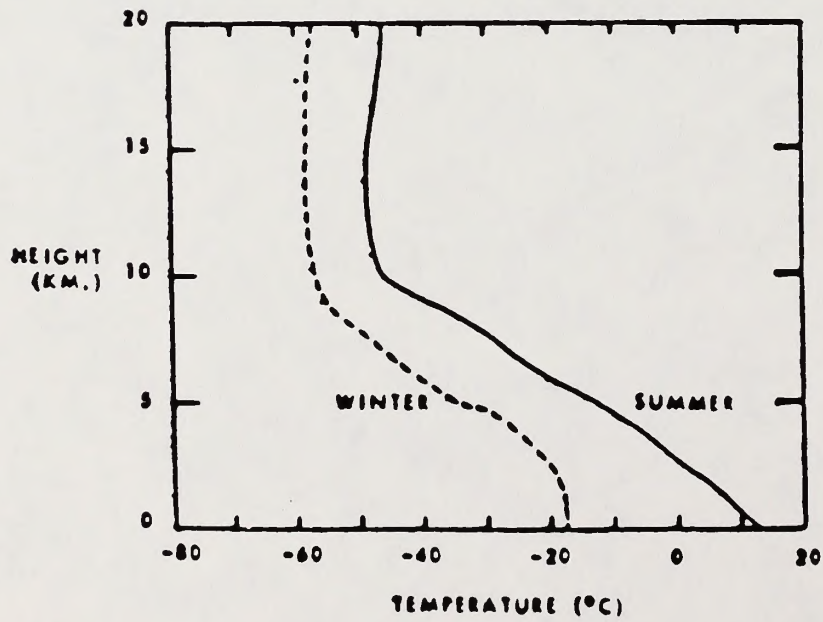

Figure 3.1-2
General Circulation Model (after Palmen)



VARIATION OF TEMPERATURE WITH HEIGHT AT 30° NORTH LATITUDE

Figure 3.1-3



VARIATION OF TEMPERATURE WITH HEIGHT AT 60° NORTH LATITUDE

Figure 3.1-4

o Horizontal Variation

Temperature also varies horizontally particularly with latitude, being colder near the poles and warmer near the equator. However, the influence of continents and oceans have considerable effects on modifying temperatures. The continents have more extreme temperatures (continental climate) becoming warmer in summer and colder in winter, whereas the oceans maintain a more moderate temperature (marine or maritime climate) year-round.

Winds

Wind is nothing more than air in motion and although it is a motion in three dimensions, usually only the horizontal component is considered in terms of direction and speed. In the free atmosphere (above the effects of the earth's friction), two forces are important. The first, the Coriolis force, is due to the tendency for the air to move in a straight path while the earth rotates underneath thereby deflecting the wind to the right in the northern hemisphere and to the left in the southern hemisphere. The deflection is proportional to the wind velocity, and decreases with latitude. The other force affecting the horizontal wind component is the pressure gradient force, which directs flow from high to low pressure. Above the friction layer, in regions where the lines of constant pressure (isobars) are straight and the latitude is greater than 20° , the two forces are in balance (See Figure 3.1-6) and the wind blows parallel to the isobars. Where isobars are curved, the forces are not in balance, their resultant producing a centripetal acceleration. In the lowest portion of the atmosphere frictional drag (not due to molecular friction but to eddy viscosity) slows down the wind speed, and because the Coriolis force is proportional to the wind speed, reduces the Coriolis force. The balance of forces under frictional flow is shown in Figure 3.1-7. It will be noted that under frictional flow the wind has a component across the isobars toward lower pressure.

Anticyclones and Cyclones

Migrating areas of high pressure (anticyclones) and low pressure (cyclones) and the fronts associated with the latter are responsible for the day to day changes in weather that occur over most of the mid-latitude regions of the earth. The low pressure systems in the atmospheric circulation are related to perturbations along the jet stream (the region of strongest horizontal temperature gradient in the upper troposphere and consequently the region of strongest winds) and form along frontal surfaces separating masses of air having different temperature and moisture characteristics. The evolution of a low pressure system is accompanied by the formation of a wave in the circulation pattern. This develops further into a warm front and a cold front both moving around the low in a counterclockwise (cyclonic)

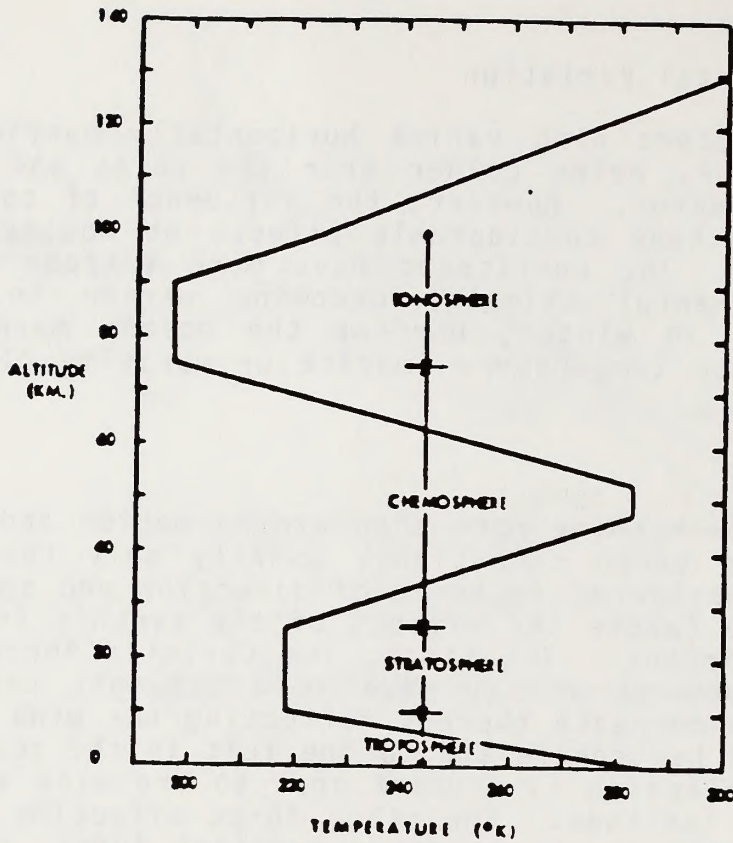

Figure 3.1-5
General Variation of Temperature with Height Throughout
the Atmosphere

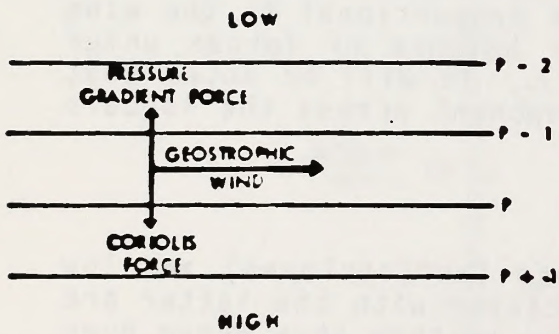

Figure 3.1-6
Balance of Forces in
the Upper Atmosphere

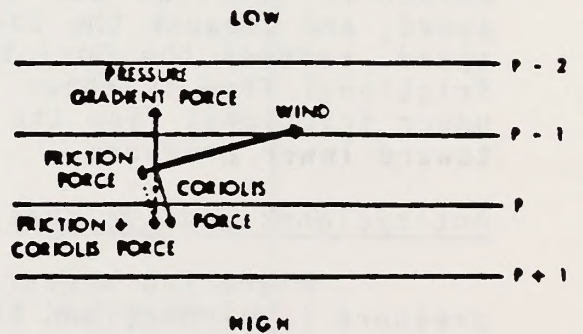

Figure 3.1-7
Balance of Forces in the
Lower (Friction Layer) Atmosphere

sense. The life cycle of a typical cyclone is shown in Figure 3.1-8. The cold front is a transition zone between warm and cold air. The cold air typically is moving toward and over the area previously occupied by warm air. Cold fronts generally have slopes from 1/50 to 1/150. Warm fronts separate advancing warm air from retreating cold air and have slopes on the order of 1/100 to 1/300 due to the effects of friction on the trailing edge of the front. Figure 3.1-9 illustrates a vertical cross section through both a warm and a cold front.

Air Masses

Air masses are frequently divided by frontal systems and are usually classified according to the source region of their recent history. Air masses are classified as maritime or continental to indicate origin over the ocean or land, and arctic, polar, or tropical depending principally on the latitude of origin. Air masses are modified by vertical motions and radiation upon the surfaces over which they move.

Condensation, Clouds, and Precipitation

Condensation of water vapor upon suitable condensation nuclei in the atmosphere causes clouds. (Table 3.1-2 indicates the relative sizes of different particles.) Large hygroscopic nuclei will condense water vapor upon them even before saturation is reached, as opposed to crystallization nuclei which promote the growth of ice crystals, at the expense of small water droplets within a supercooled cloud. Of course, only a small proportion of all clouds produce rain. It is necessary that droplets increase in size so that they will have appreciable fall velocity and also to prevent complete evaporation of the drops before they reach the ground. Table 3.1-3 indicates the distance of fall for different size drops before evaporation occurs. Growth of water droplets into rain drops large enough to fall is thought to originate predominately with the large condensation nuclei which grow larger as they fall through the cloud. The presence of an electric field in clouds generally promotes the growth of raindrops.

Table 3.1-2
Sizes of Particles

<u>Particles</u>	<u>Size (microns)*</u>
Small ions	less than 10^{-3}
Medium ions	10^{-3} to 5×10^{-2}
Large ions	5×10^{-2} to 2×10^{-1}
Aitken nuclei	5×10^{-2} to 2×10^{-1}
Smoke, haze, dust	10^{-1} to 2

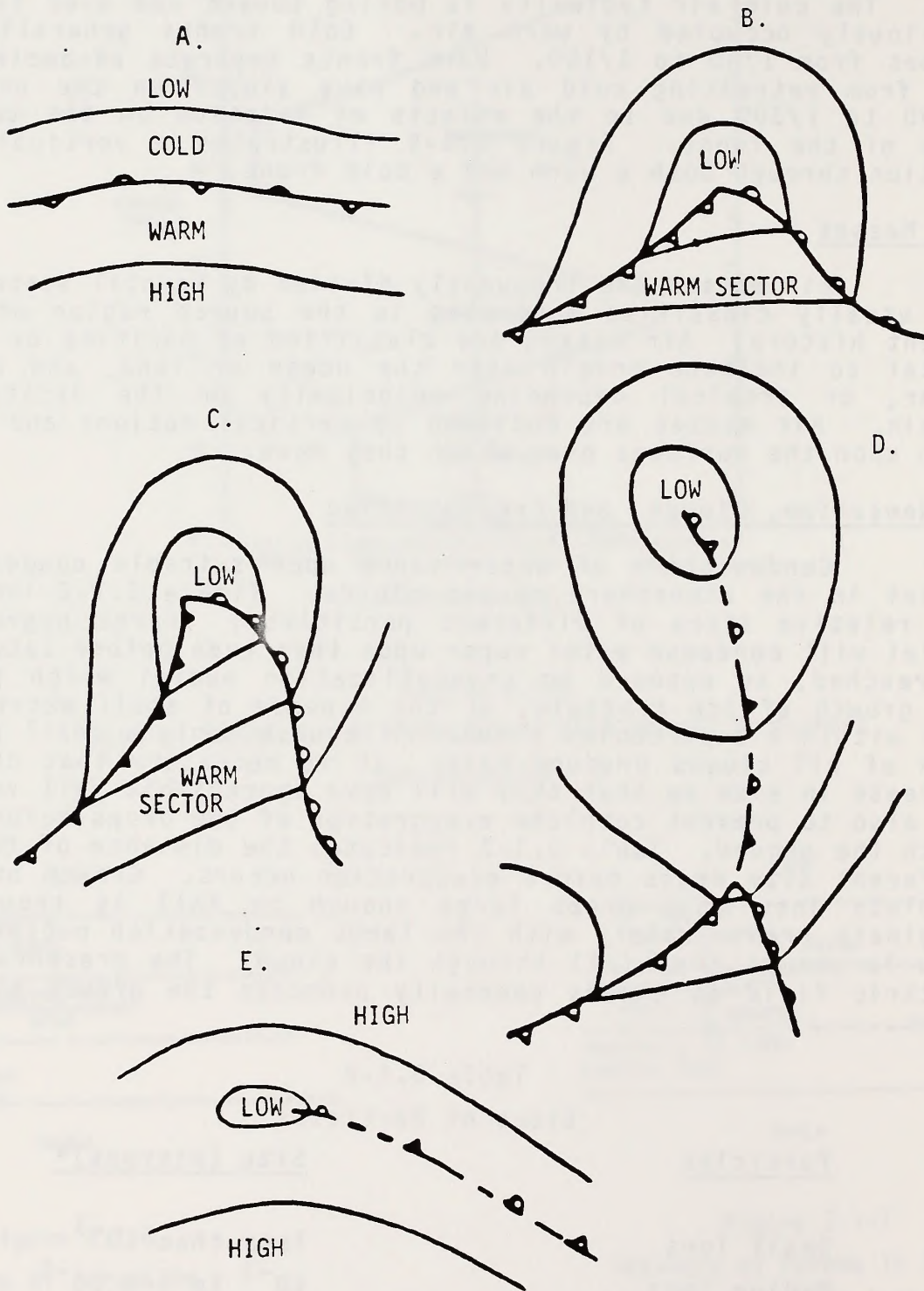
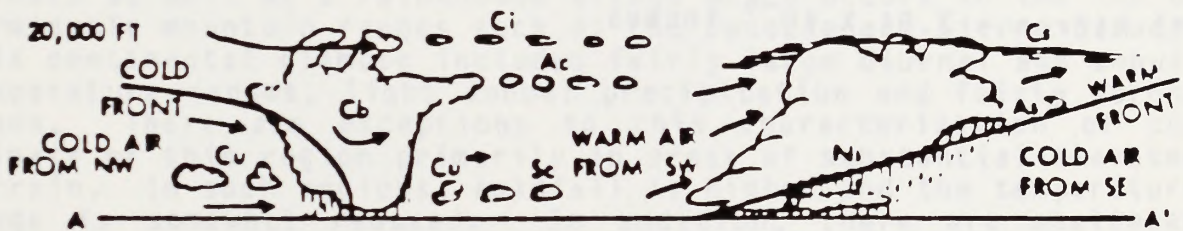
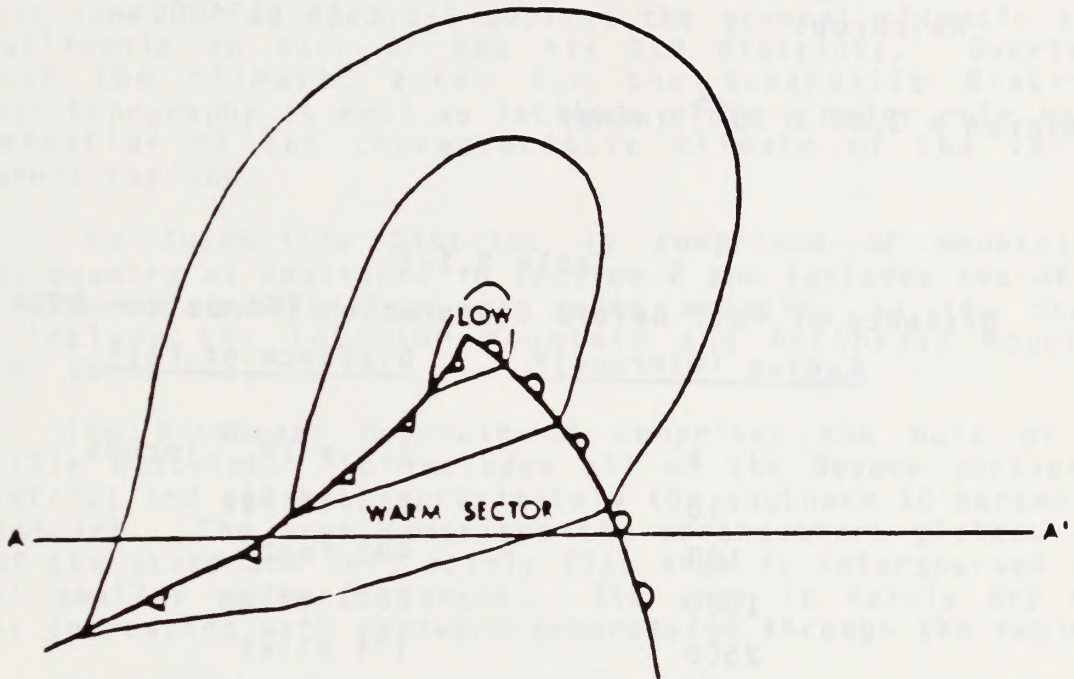

Figure 3.1-8
Idealized Development of a Low-Pressure (cyclone) System



Cross Section Through a Cold Front
and a Warm Front

Figure 3.1-9

- | | |
|-------------------|--------------------|
| Key: Ci = Cirrus | Cb = Cumulonimbus |
| Cs = Cirrostratus | Ns = Nimbostratus |
| Cu = Cumulus | Sc = Stratocumulus |
| Ac = Altostratus | As = Altostratus |

Large condensation nuclei	2×10^{-1} to 10
Giant condensation nuclei	10 to 30
Cloud or fog droplets	1 to 100
Drizzle drops	100 to 500
Raindrops	500 to 4000

*1 Micron = 3.94×10^{-5} inches

Table 3.1-3

Distance of Fall Before Evaporation (Findeison 1939)

<u>Radius (microns)*</u>	<u>Distance of Fall</u>
1	1.3×10^{-4} inches
10	1.3 inches
100	492 feet
1000	26.1 miles
2500	174 miles

*1 Micron = 3.94×10^{-5} inches

3.2 CLIMATIC ZONES

California encompasses a vast amount of territory and offers a wide variety of climate types, ranging from hot, arid desert climates to cold, moist mountain climates. It is therefore advantageous to present the climatic analysis in terms of climatic zones. Figure 3.2-1 depicts the general climatic zones for California in each of the six BLM districts. Overlay C presents the climatic zones for the Susanville District. Regional topography as well as latitude plays a major role in the determination of the characteristic climate of the various California regions.

The Susanville District is comprised of mountainous plateau country as described in Section 2 and includes two of the major climatic subdivisions or zones existing in the State. These include the Interior Mountain and Northeast Mountain Climatic Zones (CZ).

The Northeast Mountain CZ comprises the bulk of the Susanville District. It includes all of the Nevada portion of the District and all but approximately the southern 10 percent of the District. The area comprises the northeastern plateau portion of the State and this fairly flat area is interspersed with several smaller mountain ranges. The area is fairly dry with dryness increasing with eastward progression through the region.

The Northeast Mountains CZ experiences a continental climate as well as a rainshadow effect which occurs in the lee of formidable mountain ranges such as the Cascade and Sierra Nevada. This continental climate includes fairly large diurnal and annual temperature ranges, light annual precipitation and fairly strong winds. There are exceptions to this characterization of the climate of this region primarily in areas of substantial elevated terrain. In such regions, rainfall is higher and the temperature range is somewhat reduced. In addition, there are sheltered valley locations where wind speeds tend to be lighter with the concomitant implications for dispersion meteorology.

Average temperatures in the region are generally in the upper 40's to around 50 on an annual basis. Some of the coldest temperatures observed in the State are observed in this portion of the Susanville District. The area also is one of the coldest areas in the State of Nevada. Precipitation amounts vary considerably in the Northeast Mountain CZ, ranging from in excess of 40 inches in the extreme south near the Interior Mountains CZ to less than 4 inches at points along the Nevada border. Much of the Nevada portion of the Susanville District can be characterized as a true desert. Precipitation amounts are quite variable and annual totals at key plateau stations, such as Alturas and Susanville, are generally around 15 inches.

The extreme southern portion of the Susanville District is in the Interior Mountain CZ. This climatic zone is indicative

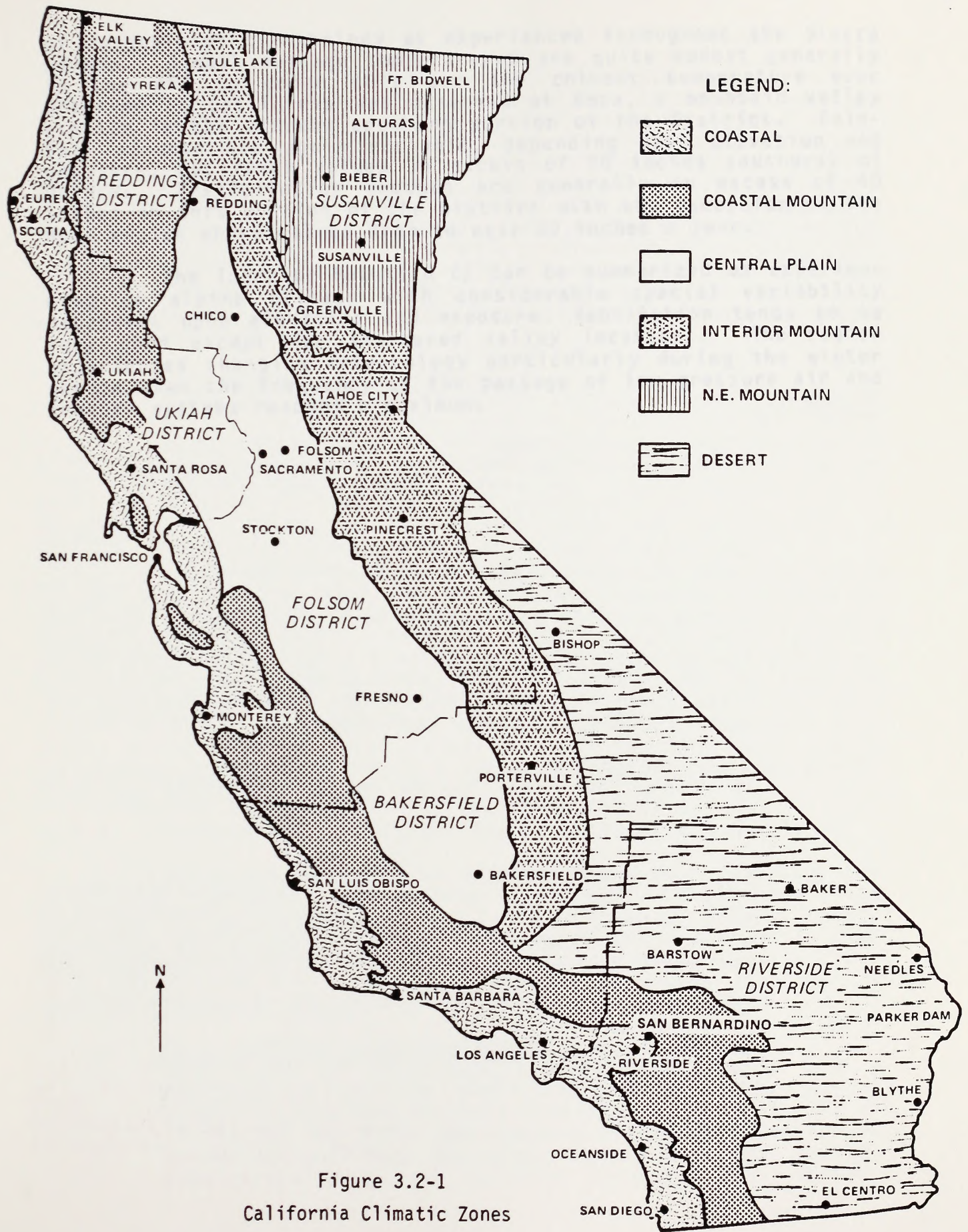

Figure 3.2-1
California Climatic Zones

of mountainous climatology as experienced throughout the Sierra Nevada. Annual average temperatures are quite modest generally in the mid to upper 40's and the coldest temperature ever observed in California was observed at Boca, a mountain valley station in the extreme southern portion of the District. Rainfall amounts are again variable, depending upon elevation and exposure, but reach values in excess of 90 inches southwest of Quincy. Precipitation amounts are generally in excess of 40 inches in this portion of the District with the exception of the Boca region where values drop to near 20 inches a year.

The Interior Mountain CZ can be summarized as experiencing an alpine climate with considerable spatial variability dependent upon elevation and exposure. Ventilation tends to be very good except for sheltered valley locations. The region experiences changing meteorology particularly during the winter season when the frequency of the passage of low pressure air and frontal systems reaches a maximum.

3.3 SOURCES OF CLIMATOLOGICAL DATA

It is necessary in the consideration of most climatological problems to obtain meteorological information. Frequently, a special observational program must be initiated as will be discussed in more detail in Section 7. However, there are also many situations where current or past meteorological records from a Weather Service station will suffice. The following outline provides a brief insight into the types of observations taken at Weather Service stations and some of the summaries compiled from this data. The discussion also serves to describe the bulk of the published data sources used in the Susanville District analysis. Many other data sources used in this report are noted in the bibliography as appropriate.

3.3.1 Observations and Records

Surface

o First Order Stations

There are 100 Weather Bureau stations where 24 hourly observations are taken daily. The measurements taken are: dry bulb temperature and wet bulb temperature (from which dew point temperature and relative humidity are calculated), pressure, wind direction and speed, cloud cover and visibility. These observations are transmitted each hour on weather teletype circuits and are entered on a form with one day to each page. The original is sent to the National Climatic Center (NCC) in Asheville, North Carolina, and a duplicate is maintained in the station files. Each station also maintains a climatological record book where certain tabulations of monthly, daily, and hourly observations are recorded.

o Second Order Stations

These stations usually take hourly observations similar to the first order stations above but not throughout the entire 24 hours of the day.

o Military Installations

Many military installations, especially Air Force Bases, take hourly observations. These are transmitted on military teletype circuits and therefore not available for general use. No routine publications of these data is done. Records of observations are sent to NCC where special summaries can be made by use of punched cards.

o Supplementary Airways Reporting Stations

These stations are located at smaller airports. Observations are not taken at regular intervals, usually being taken according to airline schedules. These observations are not published and are not available on punched cards. Original records, however, are sent to the NCC.

o Cooperative Stations

There are about 10,000 of these stations manned, for the most part, by volunteer observers. The observations are taken once each day and consist generally of maximum and minimum temperatures and 24 hour rainfall. Observations are recorded on a form with one month to a page. The original is sent to NCC, a carbon sent to the state climatologist (prior to the termination of the State Climatologist Positions), and a carbon maintained at the station. A few cooperative stations have additional data on evaporation and wind. However, the wind observations are taken only a few inches off the ground and are of use mainly in connection with the evaporation measurements.

o Fire Weather Service Stations

There are a number of special stations maintained during certain times of the year in forested regions where measurements of wind, relative humidity, and cloud cover are taken. These are generally not on punched cards nor are they summarized.

Upper Air

There are between 60 and 70 stations in the contiguous United States where upper air observations are taken twice daily (at 0000 GMT and 1200 GMT) by radiosonde balloon and radio direction-finding equipment. The measurements taken include temperature, pressure, relative humidity and wind speed and direction at several levels. These observations are transmitted to teletype and original records are sent to NCC where these data are published. Since these data are collected primarily to determine large scale meteorological patterns and have relatively little refinement in the lower 2 to 3 thousand feet of the atmosphere, they are of limited use in air pollution meteorology.

3.3.2 Climatological Data

There are a number of routine and special publications available from the Superintendent of Documents, U.S. Government Printing Office, Washington, D.C., 20402, that are useful in air pollution evaluation. A number of these are listed in Price List 48, available from the Superintendent of Documents.

Routinely Prepared Data

o Daily Weather Maps - Weekly Series

The charts in this 4-page, weekly publication are a continuation of the principal charts of the former Weather Bureau publication, "Daily Weather Map." All of the charts for 1 day are arranged on a single page after being copied. They are copies from operational weather maps prepared by the National Meteorological Center,

National Weather Service. The Surface Weather Map presents station data and the analysis for 7:00 a.m. EST.

The 500-Millibar Height Contour chart presents the height contours and isotherms of the 500-millibar surface at 7:00 a.m. EST.

The Highest and Lowest Temperatures chart presents the maximum and minimum values for the 24-hour period ending at 1:00 a.m., EST.

The Precipitation Areas and Amounts chart indicates by means of shading, areas that had precipitation during the 24 hour period ending at 1:00 a.m., EST.

o Local Climatological Data (LCD)

These data are published individually for each station and include 3 issues discussed below.

Monthly Issue LCD

This issue gives daily information on a number of meteorological variables and monthly means of temperature, heating degree days, pressure and precipitation. Also tabulated are observations at 3-Hourly Intervals (observations for each hour of the day were discontinued after December 31, 1964). This publication is usually available between the 10th and 15th of the following month.

LCD Supplement (monthly)

This issue is available for stations having 24 hourly observations daily until December 31, 1964 when publication was discontinued. For air pollution investigations, Tables B, E, F, and G would be of greatest interest (Frederick, 1964). The Supplement is usually available from 20 to 40 days after the end of the month.

LCD with Comparative Data (annual)

This issue, published annually, has a table of climatological data for the current year and a table of normals, means, and extremes for a longer period of record. This issue is usually available between 45 and 60 days after the end of the year.

o Northern Hemisphere Data Tabulations

This publication, issued daily, contains approximately 30 pages of surface synoptic observations and upper air observations. The surface data are for one hour only (1200 GCT). In this publication, the radiosonde information is of principal interest in air pollution meteorology.

o Climatological Data - National Summary

This publication of approximately 50 pages, issued

monthly, contains a narrative summary of weather conditions, climatological data (similar to those given in each station's LCD) in both English and metric units, mean monthly radiosonde data, and solar radiation data. Also included are a number of maps of the United States showing spatial distribution of temperature, precipitation, solar radiation and winds. The mean radiosonde and solar radiation data are of main interest in this publication for air pollution meteorology.

o Climatological Data (by State)

This summary, issued monthly and annually, contains data primarily on temperature and precipitation. This will provide only limited information to the air pollution meteorologist.

o Selected Climatic Maps

This publication consists of 30 U.S. maps of various meteorological parameters such as: maximum and minimum temperature, heating and cooling degree days, precipitation, relative humidity, solar radiation, and surface wind roses for January and July together with the annual wind rose. Wind data are presented for 74 locations within the contiguous U.S. A list of the basic Climatic Maps from which the generalized maps of this publication are taken is included.

Summaries

o Summary of Hourly Observation

This series of publications, Climatography of the United States, No. 82-, Decennial Census of United States Climate, has been prepared for over 100 Weather Bureau stations where 24 hourly observations are recorded. One issue is prepared for each station, and where the period of record is sufficient, the ten year period 1951 - 1960 has been considered. For other stations, the 5 year period 1956 - 1960 has been summarized. This series supersedes the series, "Climatography of the United States" No 30-, a 5 year summary published in 1956.

o Climatic Guide

This series of climatological publications contains a wealth of climatological information useful to the air pollution meteorologist fortunate enough to have had one prepared for his city. Of major interest to air pollution meteorologists, are tables of wind frequencies, solar radiation and degree days.

o Climatic Summary of the United States-Supplement for 1931 - 1952.

This summary, issued by state, contains tables of monthly and annual precipitation, snowfall, and temperature for stations within the state.

- o Terminal Forecasting Reference Manual
This manual, published by station, describes the weather conditions at the station, and contains information on local topography, visibility effects due to fog and smoke, ceiling, precipitation, special weather occurrences, and mean wind and visibility conditions. Numerous charts are included summarizing the above elements. Of special interest are surface wind roses by month and a wind rose chart related to restricted visibility conditions. A topographic and smoke source map for the station is included.

- o Key to Meteorological Records Documentation
This series of publications was established to provide guidance to those making use of observed data. A recent addition to this series No. 4.11, "Selective Guide to Published Climatic Data Sources prepared by U.S. Weather Bureau" (1969) is extremely useful to anyone contemplating use of climatic data.

The series No. 1.1 title "Substation History" and issued by state contains information regarding history of station locations, type and exposure of measuring instruments, location of original meteorological records, where published, and dates of first and last observations.

3.4 TEMPERATURE

Temperature is a critical climatological parameter for land management activities. Temperature and related parameters, such as the length of the growing season, greatly influence the suitability of land areas for utilization in agriculture, forestry and grazing.

Ambient temperatures are determined by a multitude of factors, including the following:

- o The intensity and duration of solar radiant energy
- o The degree of depletion of this energy by reflection, scattering and absorption in the atmosphere
- o The surface albedo
- o The physical characteristics of the surface such as terrain types
- o The local heat budget in terms of terrestrial and atmospheric radiation
- o Heat exchanges involved in water phase changes
- o Importation or advection of warm or cold air masses by horizontal air movement
- o Transport of heat upward or downward by vertical air currents caused by natural convection and/or mechanical turbulence

In the United States, temperature is most commonly measured in degrees Fahrenheit ($^{\circ}\text{F}$), however, there is an increasing trend towards the use of degrees Centigrade ($^{\circ}\text{C}$). For this reason, temperature data and analyses presented in this report are in degrees Fahrenheit, with Table 3.4-1 providing a summary of temperature conversion information for aid in the usage of both systems.

Temperature data are available for numerous stations in California. For this reason, key stations have been used to represent the various climatic zones in the district in an effort to limit the amount of data analysis necessary to present the required information. Once again, the Susanville District has been divided into two key climatic zones in which temperature is fairly homogeneous. For each of these regions, data from the selected key stations has been used to describe temperature characteristics. Data provided for each of the key stations includes monthly and annual means, mean maximum, mean minimum as well as the record high and low temperatures.

Table 3.4-1

TEMPERATURE CONVERSIONS

Temperatures in this publication are given in degrees Fahrenheit (°F). The Celsius (C) temperature scale, also called Centigrade, is used in most countries of the world. A temperature conversion scale is shown on the left, note that the values coincide only at the -40 degree mark.

°F	°C	
212	100	1. { Water Boils
194	90	
176	80	
158	70	
140	60	2. { U.S. Record High
134	56.7	
122	50	
104	40	
86	30	
68	20	
50	10	
32	0	1. { Water Freezes
14	-10	
-4	-20	
-22	-30	
-40	-40	{ Scales Coincide
-58	-50	
-76	-60	
-94	-70	3. { U.S. Record Low
-112	-80	
-130	-90	
-148	-100	

The standard formulas to convert °F to °C and °C to °F are shown below:

$$°F = 9/5 °C + 32$$

$$°C = 5/9 (°F - 32)$$

Alternate, easy to remember conversion methods follow:

$$°F = 9/5 (°C + 40) - 40$$

$$°C = 5/9 (°F + 40) - 40$$

To use the alternate conversion formulas for converting from one scale to the other:

- add 40 to the value to be converted
- multiply that sum by the fraction:
(5/9 for °F to °C)
(9/5 for °C to °F)
- subtract 40 from the product

For example, to convert 68°F to °C:

- add 40: 68+40 = 108
- multiply the sum by 5/9 (°F to °C):
5/9x108 = 60
- subtract 40: 60-40 = 20
- answer: 68°F = 20°C

- Under Standard Sea Level Pressure
- Greenland Ranch, CA - July 10, 1913
- Rogers Pass, Montana - January 20, 1954

Figure 3.4-1 presents the two climatic zones superimposed on the district map with selected station locations for which temperature data are available. Tables 3.4-2 and 3.4-3 summarize the temperature statistics for these stations in each climatic zone. Section 3.2 briefly summarizes temperature and other climatic characteristics of each climatic zone.

3.4.1 Mean Temperature Distribution

The data presented in the figures and tables in this section provide generalized information for BLM lands located within each of the study regions. However, temperature is a variable which is subject to microclimatological effects and the actual temperature at a given location will depend upon several variables as previously indicated. The data show that variability among stations within a particular region is fairly modest and that the average values provided in the summary figures can be used with a good degree of confidence. Caution when using these values is warranted when the location of interest varies significantly from the elevation of the key stations or if a particular location experiences important micro-scale effects (e.g., anomalous ground cover conditions).

Annual Average

Figure 3.4-2 provides the mean annual temperature distribution for the Susanville District and also appears as Overlay D. The figure shows a modest 6°F range mean annual temperature across the region from a low of 44°F in southeastern Sierra County to a high of 50°F in portions of eastern Plumas and Lassen Counties. The Susanville District portions of California and Nevada comprise some of the coolest areas in both states. Actual mean annual temperatures are dependent upon station elevation with the lowest values being observed in areas of substantial elevated terrain. The highest values on the other hand are located in relatively low lying areas, such as those areas east of Susanville. The limited range in temperature across the region reflects the relative homogeneity of areas not located in substantially elevated terrain within the District. The Susanville District lying east of the Cascade and Sierra Nevada Ranges experiences a fairly similar continental regime throughout, resulting in the homogenous nature of mean annual temperatures as depicted in Figure 3.4-2.

Mean maximum and mean minimum temperature data are summarized in Figures 3.4-3 through 3.4-5 for the two major climatic zones in the Susanville District on a monthly basis. The data show excellent temporal agreement between the two climatic zones reflecting the homogenous trend in annual average temperatures exhibited in Figures 3.4-2. The Interior Mountain Cz is consistently 5 to 10 degrees cooler than the Northeast Mountain zone reflecting its higher terrain. The figures indicate the considerable temperature range exhibited in this region both on a monthly and diurnal basis.

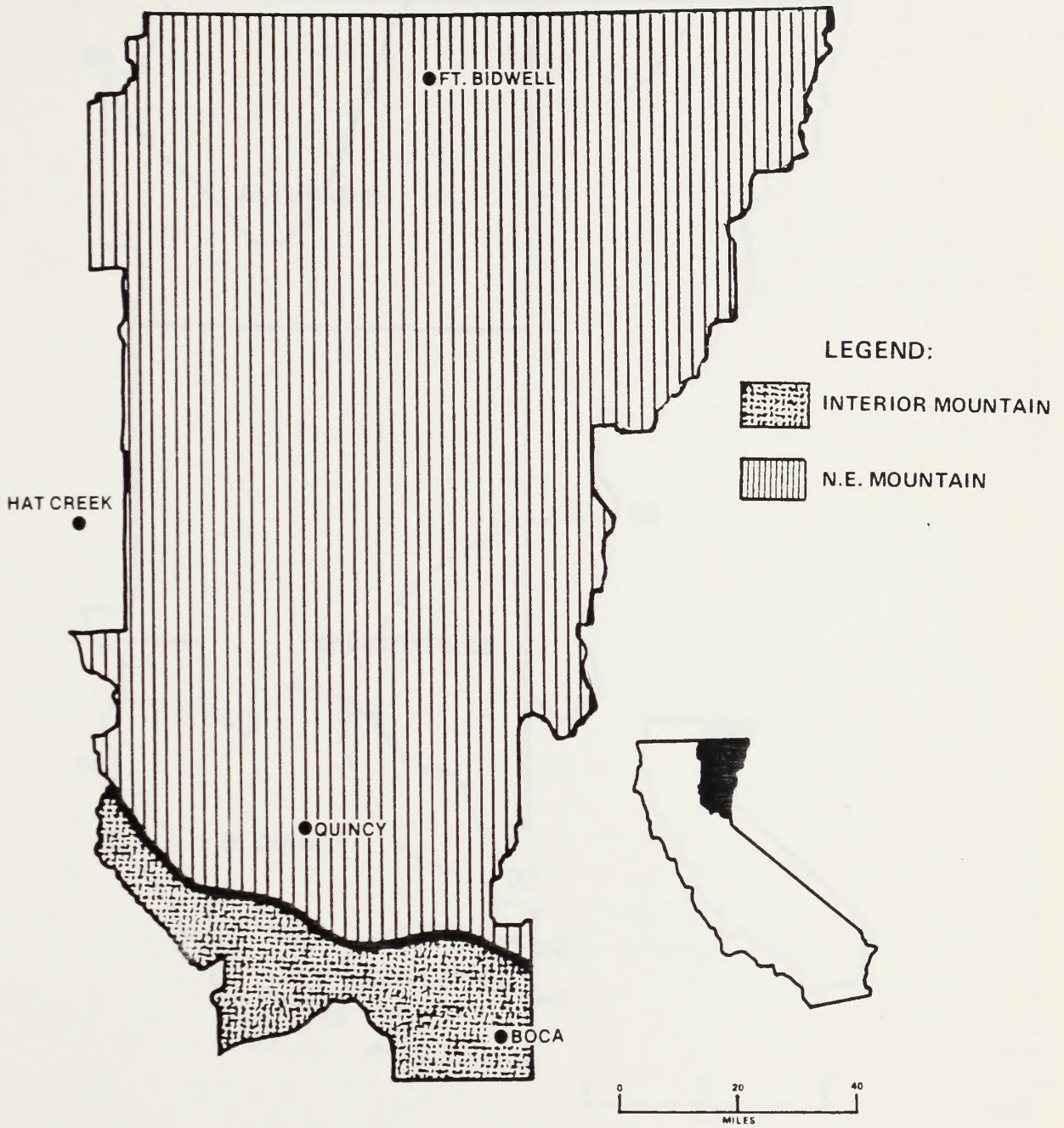

Figure 3.4-1
 Temperature Stations for the Susanville District

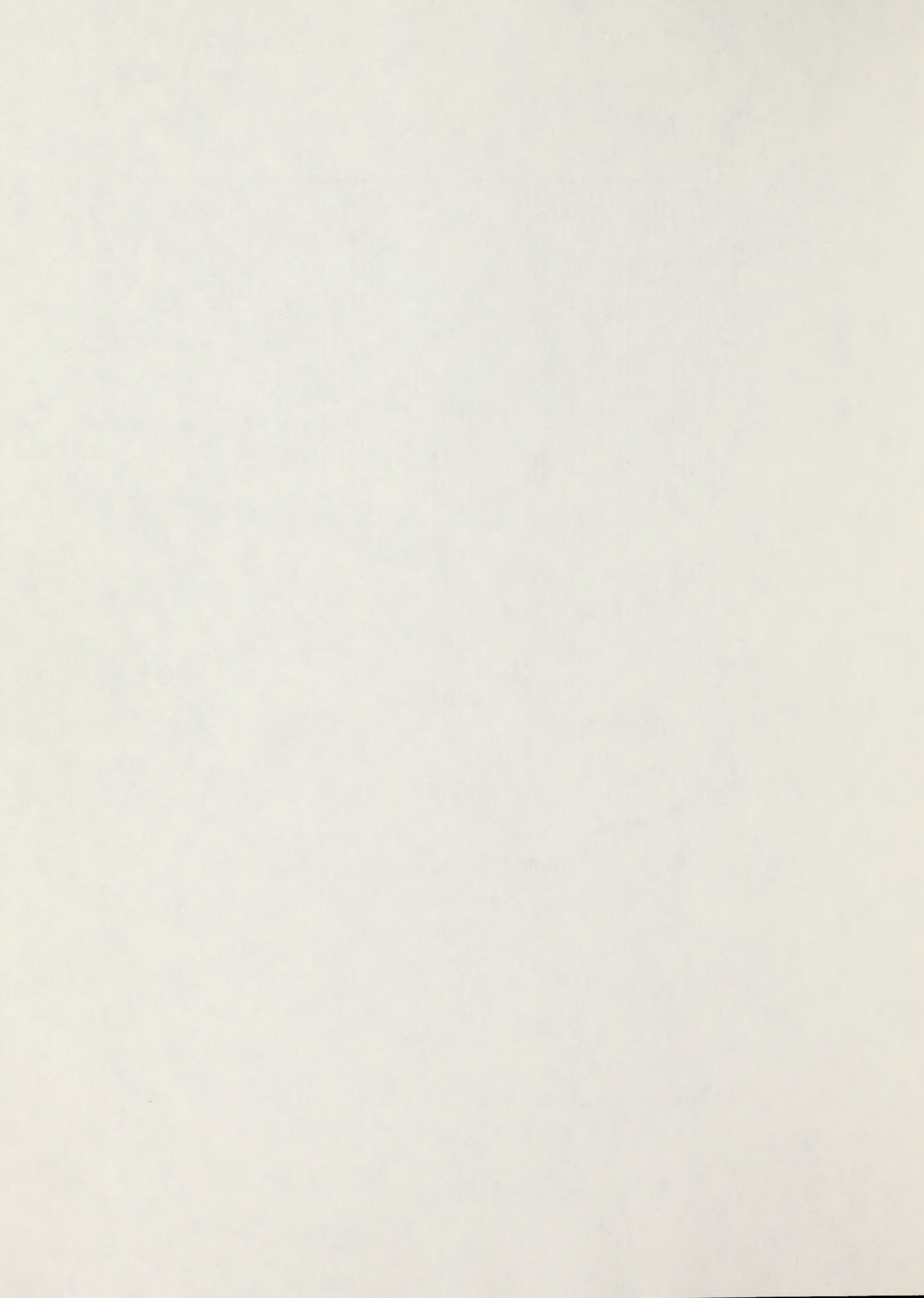



Figure 3.4-2
 Mean Annual Temperature Contours ($^{\circ}$ F)
 in the Susanville District

Source: Climatology of the U. S. #60-4, 1970

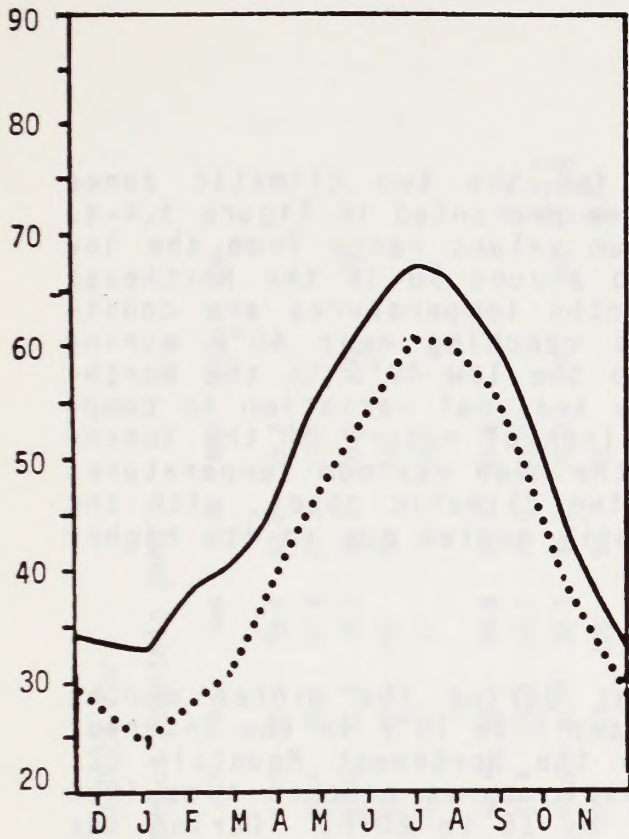

Figure 3.4-3
Susanville District
Mean Temperature

Figure 3.4-4
Susanville District
Mean Maximum Temperature

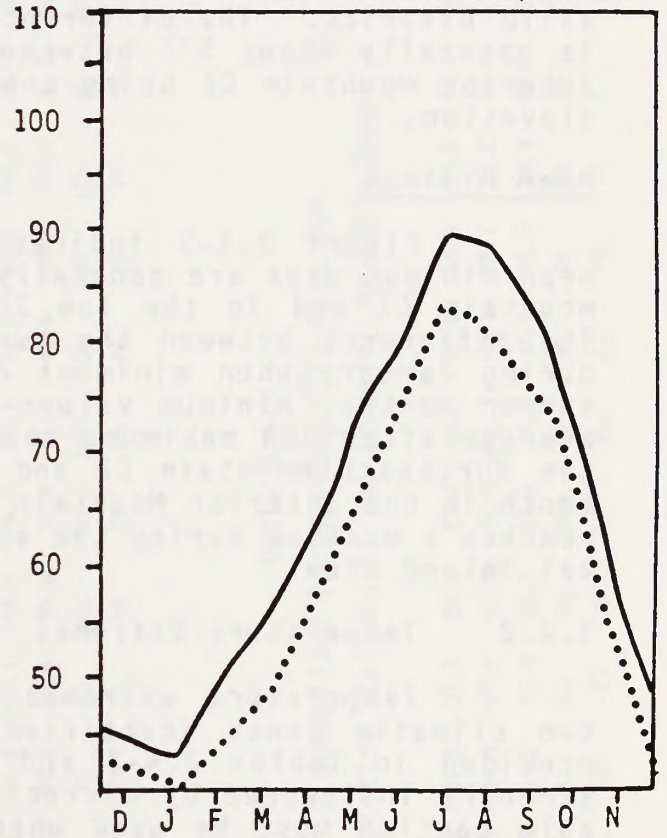
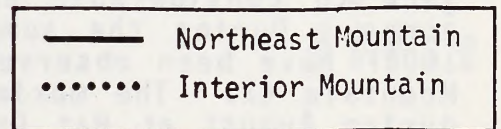
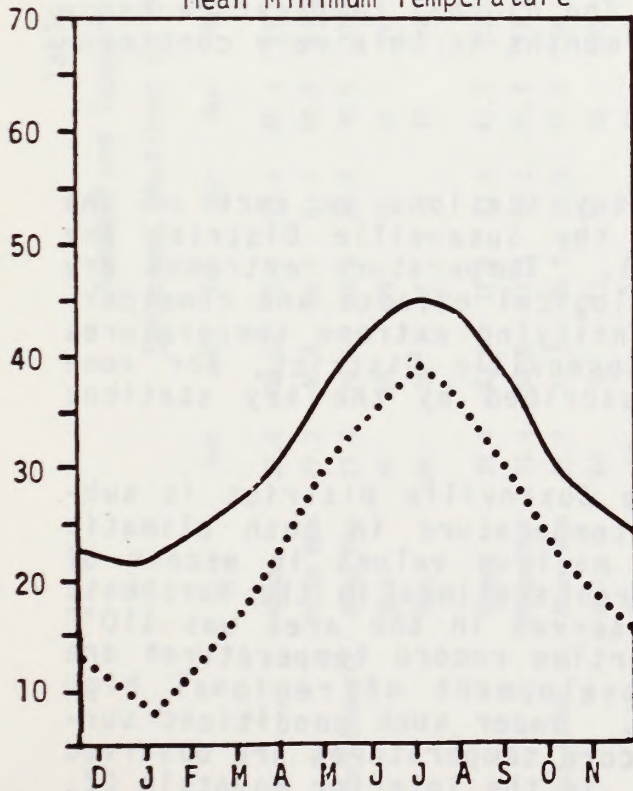

Figure 3.4-5
Susanville District
Mean Minimum Temperature



Mean Maximum

Mean maximum temperatures for the two climatic zones located in the Susanville District are presented in Figure 3.4-4. The data indicate that summer maximum values range from the low 80's in the Interior Mountain CZ to around 90 in the Northeast Mountain CZ. During the winter months temperatures are considerably cooler with maximum values reaching near 40°F during January in the Interior Mountains to the low 40's in the Northeast Mountain CZ. This considerable seasonal variation in temperatures reflects the extremely continental nature of the Susanville District. The difference in the mean maximum temperatures is generally about 5°F between the two climatic zones, with the Interior Mountain CZ being consistently cooler due to its higher elevation.

Mean Minimum

Figure 3.4-5 indicates that during the winter months mean minimum days are generally between 5 to 10°F in the Interior mountain CZ and in the low 20°F in the Northeast Mountain CZ. The difference between the two climatic zones reaches a maximum during January when minimums differ by 15 to 20°F. During the summer months, minimum values are quite cool in comparison with average afternoon maximums reaching the mid 40's during July in the Northeast Mountain CZ and the upper 30's during the warmest month in the Interior Mountain CZ. The diurnal temperature range reaches a maximum during the summer months in this very continental inland area.

3.4.2 Temperature Extremes

Temperature extremes for key stations in each of the two climatic zones identified for the Susanville District are provided in Tables 3.4-2 and 3.4-3. Temperature extremes are strongly influenced by microclimatological effects and considerable caution must be used when identifying extreme temperatures for use at locations within the Susanville District, for some locations may not be adequately described by the key stations provided in the tables.

The data indicate that the Susanville District is subject to considerable extremes in temperature in both climatic zones. During the summer season, maximum values in excess of 100°F have been observed at the three stations in the Northeast Mountain CZ. The maximum value observed in the area was 110°F during August at Hat Creek. Summertime record temperatures are generally associated with the development of regional high pressure over the desert southwest. Under such conditions surface heating becomes intense and record temperatures are observed particularly at low lying stations. In the Interior Mountain CZ, data are available from Boca which indicate a maximum record temperature of 98°F, which has occurred during both July and August.

Table 3.4-2
Summarized Temperature (°F) Data for
Selected Stations in the Northeast Mountain Zone

	Dec	Jan	Feb	Mar	Apr	May	Jun	Jul	Aug	Sep	Oct	Nov	High	Low	
Fort Bidwell	Mean	31.8	30.5	35.2	39.0	45.3	53.6	60.4	67.2	65.5	59.4	50.0	39.2		
	Mean Max	42.3	40.4	46.0	51.4	60.0	69.6	77.3	86.4	85.1	78.9	67.3	51.9		
	Mean Min	21.4	20.6	24.5	26.5	30.5	37.7	43.4	47.9	45.8	39.9	32.7	26.7	100	-26
	Max	66	65	69	80	82	91	96	99	100	100	88	77		
	Min	-26	-26	-12	-5	10	19	26	32	31	17	5	-2		
Hat Creek	Mean	34.4	33.4	37.8	41.5	47.2	55.4	62.3	68.4	66.1	60.6	51.2	41.4		
	Mean Max	46.4	45.6	51.3	56.1	63.4	73.4	81.8	91.4	89.4	83.7	71.0	55.8		
	Mean Min	22.2	21.3	23.3	26.9	31.0	37.3	42.8	45.4	42.9	37.5	31.3	26.9	110	-20
	Max	64	65	73	81	86	98	102	108	110	106	94	82		
	Min	-20	-8	-1	9	18	22	27	32	31	22	14	8		
Quincy	Mean	34.7	33.9	38.8	42.3	47.3	55.1	61.9	67.1	64.8	60.1	51.3	41.6		
	Mean Max	45.8	45.3	51.9	57.1	64.0	74.0	82.4	91.3	89.5	84.7	72.0	55.5		
	Mean Min	23.4	22.5	25.6	27.4	30.6	36.3	41.4	42.9	40.2	35.5	30.5	27.7	108	-24
	Max	64	67	72	83	86	95	104	106	108	105	95	83		
	Min	-24	-8	-7	0	16	22	25	29	25	15	15	7		

Table 3.4-3
Summarized Temperature (°F) Data for
Selected Stations in the Interior Mountain Zone

	Dec	Jan	Feb	Mar	Apr	May	Jun	Jul	Aug	Sep	Oct	Nov	High	Low	
Boca	Mean	27.3	24.4	27.6	31.7	38.9	47.4	54.1	60.6	58.5	53.0	44.7	35.8		
	Mean Max	42.4	40.2	44.1	47.6	55.0	64.9	73.1	83.1	81.7	76.2	65.4	51.7		
	Mean Min	12.0	8.5	11.2	15.9	22.7	29.9	34.6	38.0	35.5	29.9	23.9	19.7	98	-39
	Max	70	63	67	76	78	89	94	98	98	95	85	79		
	Min	-31	-39	-37	-27	0	14	16	22	18	14	4	-6		

During the winter months record temperatures for the Susanville District represent some of the coldest temperatures ever observed in the states of California and Nevada. Boca, located in the Interior Mountain CZ, has recorded an all time minimum temperature of -39°F in January. Temperatures lower than -30°F have occurred during December, January and February at this mountain station. In the Northeast Mountain CZ, temperatures below -20°F have occurred at each station with a regional minimum of -26°F at Fort Bidwell. It is interesting to note that record minimum temperatures of freezing or lower have been observed during every month of the year at all four stations. In addition, temperatures of 0°F or lower have occurred as late as April at Boca.

3.4.3 Frost-Free Period

The growing season varies considerably as a function of specific crop types. Some types of vegetation continue to grow when air temperatures are near freezing (32°F), whereas other forms of plant life die at temperatures above freezing. In general, it is convenient to define the growing season for a particular region by noting the mean number of days between the first and last occurrence of freezing temperatures, i.e., the frost-free period.

The mean length of the growing season is depicted by isolines of 50 day intervals for the entire Susanville District in Figure 3.4-6. As indicated in the figure the growing season length is relatively short throughout the Susanville District and is very erratic on an annual basis. The growing season data have been presented for Fort Bidwell, Hat Creek, Quincy, and Boca, within the region and these data are presented in Table 3.4-4. The available data indicate that mean growing season length for a sixteen year period from 1960 through 1976 is just in excess of 100 days at Hat Creek and Fort Bidwell. The average drops off to 75 days at Quincy and is a very modest 9 days at Boca. The growing season length is quite minimal due to the very low minimum temperatures at each station on a monthly basis and the existence of record temperatures below freezing during every month of the year.

The growing season length is very undependable throughout the Susanville District. At Fort Bidwell, for example, the growing season length was only five days in 1976. At Hat Creek the growing season length was only seven days in 1966, while at Quincy the growing season length reached a low of 21 days during 1966. Finally, at Boca there was no growing season during 1961, 1962, 1966, 1973, 1975 and 1976. On the other hand, values in excess of the average growing season length do not range far from the mean with a maximum value of only 136 days at Fort Bidwell, 124 at Hat Creek, 123 days at Quincy, and just 45 days at Boca.

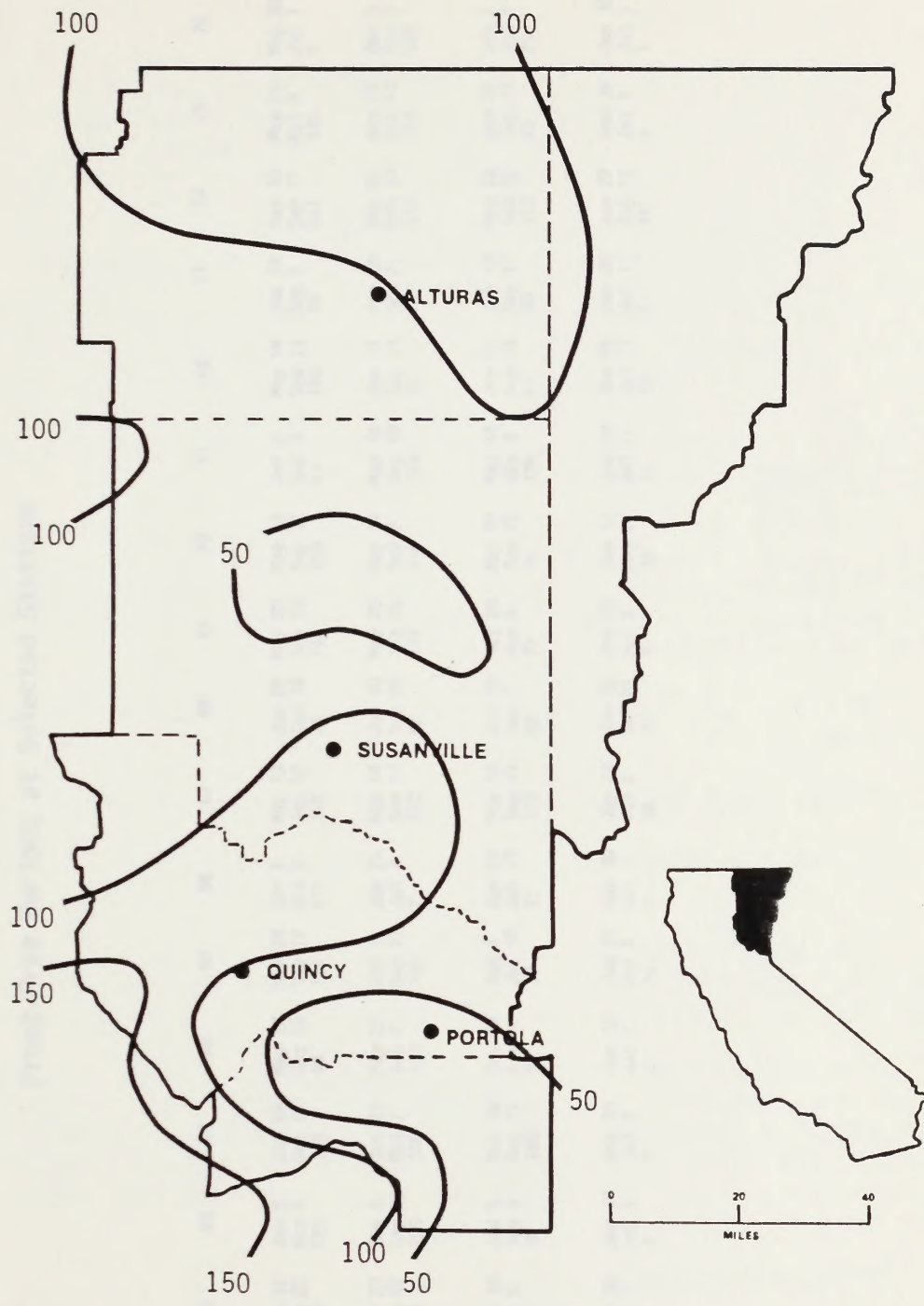

Figure 3.4-6
 Susanville District
 Frost-Free Period or Length of Growing Season by 50-Day Intervals

Table 3.4-4
Susanville District
Frost-Free Periods at Selected Stations

	60	61	62	63	64	65	66	67	68	69	70	71	72	73	74	75	76	Average
FORT BIDWELL																		
Last Spring 32°F	May 23	May 16	Jun 5	Jun 29	May 22	May 24	Jun 4	May 13	Jun 29	May 20	May 15	Jun 2	May 18	Jun 18	May 20	May 25	May 20	May 16
First Fall 32°F	Aug 23	Sep 22	Oct 5	Oct 12	Aug 29	Sep 17	Oct 3	Sep 12	Sep 16	Sep 15	Sep 12	Sep 3	Sep 11	Sep 2	Sep 27	Oct 8	Jul 1	Sep 13
Julian Days	92	129	122	105	99	116	121	122	79	118	120	93	116	76	111	136	5	104
HAT CREEK																		
Last Spring 32°F	May 22	May 27	Jun 5	Jun 29	May 22	Jun 1	Jun 25	May 14	Jun 30	May 20	May 14	May 18	Jun 11	Jun 18	May 22	Jun 25	Jun 5	Jun 4
First Fall 32°F	Aug 23	Sep 22	Sep 19	Oct 7	Sep 2	Sep 17	Jul 2	Sep 13	Sep 20	Sep 15	Sep 5	Sep 19	Sep 11	Sep 2	Sep 13	Oct 14	Oct 3	Sep 12
Julian Days	93	118	106	100	103	108	7	122	82	118	114	124	92	76	114	111	120	100
QUINCY																		
Last Spring 32°F	Jun 21	Jun 10	Jun 5	May 10	May 23	Jun 1	Jun 22	May 14	Jun 30	May 20	May 20	May 18	Jun 11	Jun 18	May 22	Jun 26	Jun 6	Jun 4
First Fall 32°F	Aug 23	Jul 6	Sep 9	Aug 24	Aug 29	Jul 10	Jul 13	Sep 14	Sep 7	Aug 6	Aug 24	Sep 3	Aug 15	Aug 17	Sep 12	Sep 27	Jul 1	Aug 18
Julian Days	63	26	96	106	98	39	21	123	69	78	96	108	65	60	113	93	25	75
ROCA																		
Last Spring 32°F	Jun 30	Jun 30	Jun 30	Jun 30	Jun 30	Jun 15	Jun 30	Jun 23	Jun 30	Jun 29	Jun 17	Jun 29	Jun 25	Jun 30	Jun 27	Jun 30	Jun 30	Jun 28
First Fall 32°F	Jul 10	Jul 1	Jul 1	Jul 2	Jul 2	Jul 1	Jul 1	Jul 9	Jul 21	Jul 3	Aug 1	Jul 11	Jul 11	Jul 1	Jul 11	Jul 1	Jul 1	Jul 7
Julian Days	10	1	1	2	2	16	1	16	21	4	45	12	12	1	14	1	1	9

3.5 PRECIPITATION

Precipitation plays a very important role in the effective management of large land areas for agriculture, forest management, energy development or other pertinent interests. Precipitation is one of the most basic of climatological parameters and is best described in terms of seasonal and annual means and extremes coupled with a discussion of the type of precipitation experienced in a given area. A region can be prone to either general prolonged rainfall or precipitation occurrences in short, violent bursts, such as heavy showers or thunderstorms. The nature of the precipitation is almost equal in importance to the amount of precipitation in terms of the effectiveness of the moisture for interests such as agriculture. In addition, the type of precipitation (i.e., liquid vs. frozen) and the amount of each also plays an important role.

Precipitation results from the expansion and cooling of ascending air. Therefore, it is important to investigate and understand the atmospheric conditions that cause large masses of air to spontaneously rise. Three characteristic causes that can result in precipitation are:

- o Convective lifting due to unstable atmospheric conditions
- o Orographic or terrain-induced lifting of air masses
- o Large scale atmospheric disturbances

The three are not mutually exclusive, and precipitation is generally not the result of just one type, but more often the joint action of several types of atmospheric lifting processes.

The following sections provide a detailed breakdown of precipitation amounts, types and frequencies. Seasonal and annual means and extremes are provided as well as rainfall intensity, and a detailed discussion on snowfall. More unusual types of precipitation such as hail are discussed in the section provided on severe weather.

3.5.1 Annual Distribution

Figure 3.5-1 presents a base map which includes the selected stations for which precipitation data are available. A climatic zone overlay (Overlay C) for the Susanville District is suitable for use with the precipitation maps.

Precipitation in California and within the Susanville District is primarily the result of the influence of maritime Pacific air and orographic influences imposed by the substantial terrain within the region. The neighboring Pacific Ocean serves as the major moisture source for precipitation in the district.

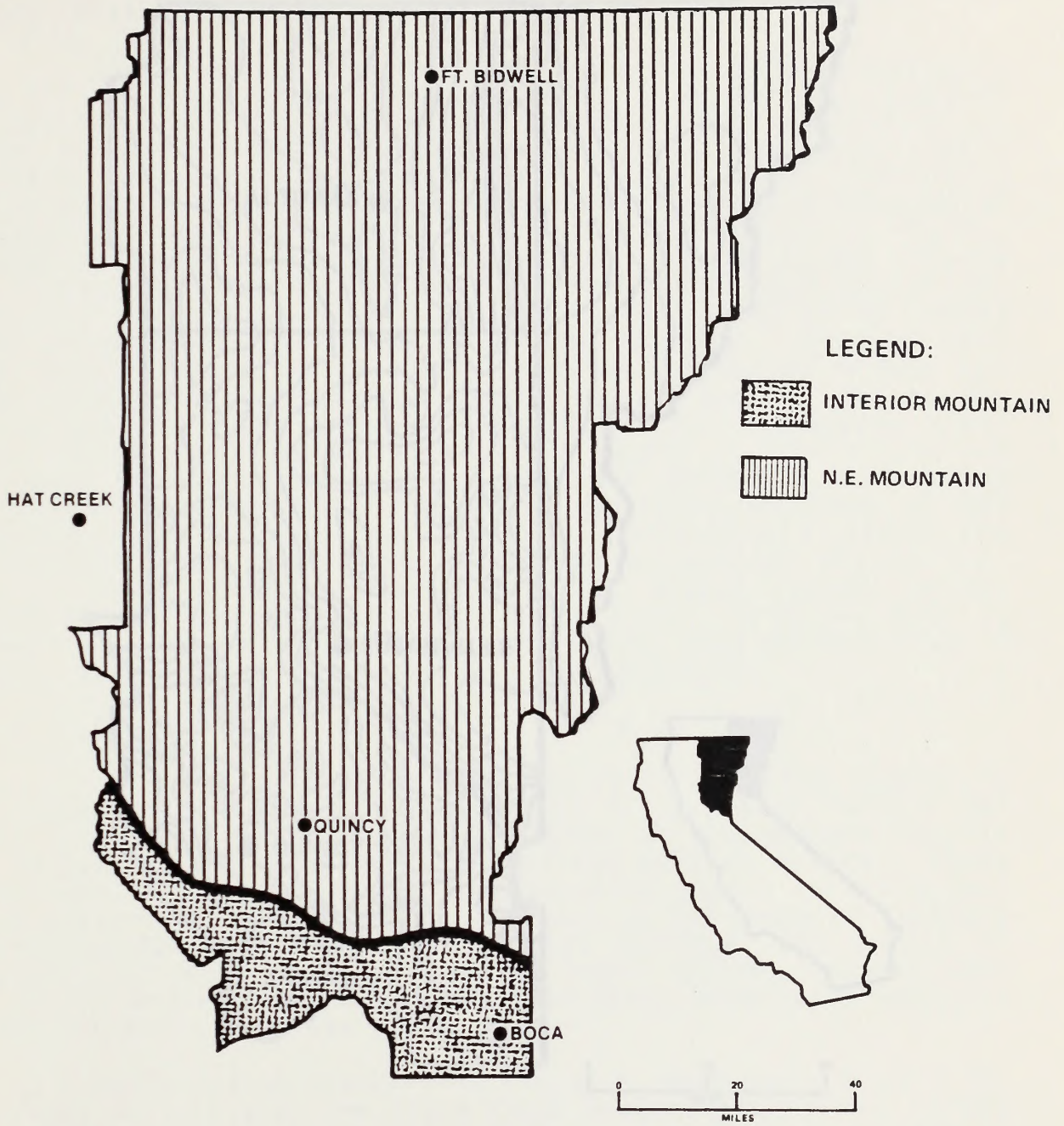

Figure 3.5-1
 Selected Precipitation Stations
 for the Susanville District

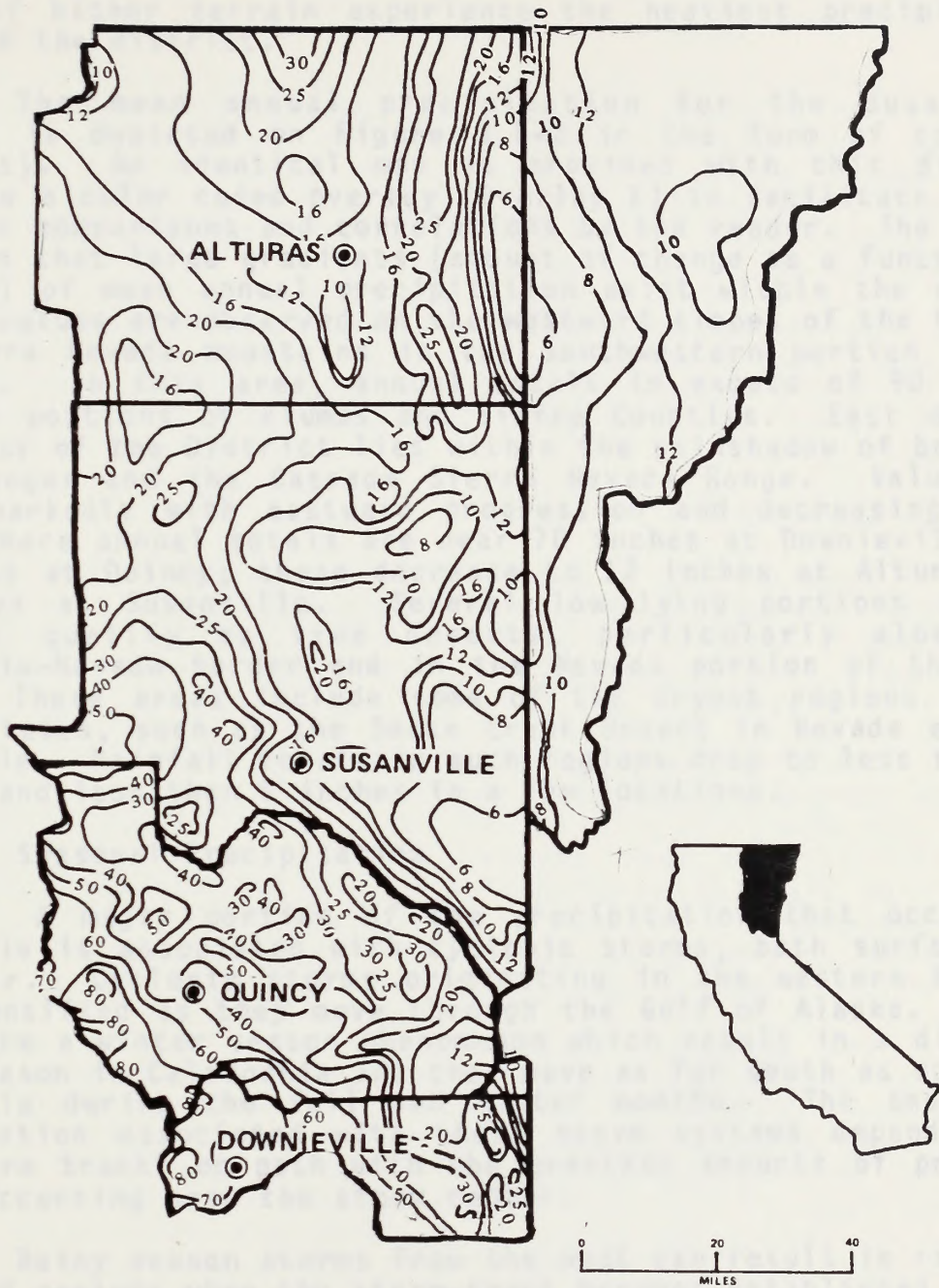

Figure 3.5-2
 Mean Annual Precipitation (Inches) in the Susanville District

Source: State of California, "Vegetative Water Use in California, 1974"

Therefore, locations closest to the south and westward facing slopes of higher terrain experience the heaviest precipitation totals in the district.

The mean annual precipitation for the Susanville District is depicted on Figure 3.5-2 in the form of contours (isohyets). An identical map is provided with this district report as a color coded overlay (Overlay E) to facilitate inter-parameter comparisons and correlations by the reader. The figure indicates that large gradients (amount of change as a function of distance) of mean annual precipitation exist within the region. Maximum values are observed on the westward slopes of the Cascade and Sierra Nevada mountains in the southwestern portion of the District. In this area, annual totals in excess of 90 inches occur in portions of Plumas and Sierra Counties. East of this area, most of the District lies within the rainshadow of both the Coast Ranges and the Cascade Sierra Nevada Range. Values decrease markedly with eastward progression and decreasing altitude. Where annual totals are near 70 inches at Downieville and 40 inches at Quincy; these decrease to 12 inches at Alturas and 16 inches at Susanville. Several low lying portions of the District qualify as true deserts, particularly along the California-Nevada border and in the Nevada portion of the District. These areas include some of the driest regions in the United States, such as the Smoke Creek Desert in Nevada east of Susanville. Rainfall totals in such regions drop to less than 10 inches, and less than 5 inches in a few locations.

3.5.2 Seasonal Precipitation

A major portion of the precipitation that occurs in California is associated with cyclonic storms, both surface and upper air. Cyclonic storms originating in the western Pacific are intensified as they move through the Gulf of Alaska. These storms are a winter season phenomenon which result in a distinct rainy season in California and they move as far south as southern California during the fall and winter months. The amount of precipitation associated with these storm systems depends upon the "storm track" or path with the greatest amounts of precipitation occurring near the storm center.

Rainy season storms from the west can result in rain for prolonged periods when the storm-track becomes established across central California. Rains may last for a week or more in coastal portions of the State and in the mountains, with only partial clearing between episodes. The actual amount of precipitation at a given station in the District, therefore, will be dependent upon such factors as (1) storm path, (2) station elevation and (3) nearby terrain features.

Storms from the southwest are the least common type of rainy season system but they occasionally bring heavily saturated air masses which can result in considerable flooding during the winter season. Southern California is most often effected by

this type of storm and the Susanville District rarely experiences this phenomenon.

Table 3.5-1 provides monthly precipitation means and extremes for selected station locations throughout the Susanville District. A review of these statistics indicates that in each of the climatic zones, a definite rainy season exists between late fall and early spring. Windward slopes of the Sierra Nevada Range experiences the greatest precipitation totals. This accounts for the high values at Quincy.

Rainy season, cyclonic storm and frontal activity throughout the District and summer season convective shower activity in the mountains and high plateau regions constitute the primary forms of precipitation observed in the Susanville District.

3.5.3 Snowfall

Snowfall is a common occurrence within the Susanville District. However, snow generally accumulates only in the higher elevations. Table 3.5-2 provides the historical record of maximum monthly snowfall amounts for various stations throughout the Susanville District.

Table 3.5-3 provides the mean monthly and mean annual maximum snowpack depth and associated water content for stations within the mountainous areas of the Susanville District. Figure 3.5-3 illustrates that several snow basins are located in the Susanville District as organized by the California Department of Water Resources, Division of Flood Management. Snow basins are determined according to particular river systems in which snow melt can contribute a significant water supply.

The greatest snowfall on record for the entire snow season in California fell in 1906 and 1907 at Pomerac in Alpine County where 884 inches of snow was recorded at 8000 feet MSL. The average seasonal snowfall at that station is 450 inches. The greatest 24-hour snowfall occurred at Giant Forest in Sequoia National Park at 6360 feet MSL on January 19, 1933 when 60 inches fell. It should be noted that there are relatively few snow observation stations in the Sierra, therefore, snowfall amounts in excess of these record amounts may have occurred.

In the Susanville District, highest monthly snowfall amounts occurred at Boca, with a 93 inch accumulation in March. Quincy has had 90 inches of snowfall during January.

3.5.4 Precipitation Frequency

An analysis of rainfall intensity for selected areas offers added insight into regional precipitation characteristics. Rainfall frequency and intensity studies, sometimes referred to as pluvial indices, provide an understanding of the nature of

Table 3.5-1
 Susanville Precipitation (Inches)
 Monthly Means and Extremes
 (1951 - 1976)

Station	Jan	Feb	Mar	Apr	May	Jun	Jul	Aug	Sep	Oct	Nov	Dec	Annual	
Fort Bidwell	Mean	2.51	1.85	1.58	1.02	1.06	0.89	0.43	0.56	1.11	1.99	2.54	15.98	
	Max	5.12	3.94	4.87	2.95	4.30	2.07	2.50	1.93	5.69	5.79	8.94	8.94	
	Min	NA	NA	NA	NA	NA	NA	NA	NA	NA	NA	NA	NA	NA
Hat Creek	Mean	3.25	2.29	2.01	1.13	1.18	0.93	0.25	0.52	1.26	2.18	3.24	18.56	
	Max	7.06	5.19	6.24	3.44	3.18	3.38	1.50	2.25	7.98	5.96	8.32	8.32	
	Min	NA	NA	NA	NA	NA	NA	NA	NA	NA	NA	NA	NA	NA
Quincy	Mean	8.86	6.24	5.17	2.98	1.54	0.73	0.18	0.62	2.81	5.24	7.34	41.55	
	Max	22.77	17.15	16.20	9.28	5.43	3.05	1.89	3.73	17.05	18.70	25.57	25.57	
	Min	NA	NA	NA	NA	NA	NA	NA	NA	NA	NA	NA	NA	NA
Boca	Mean	4.25	2.82	2.58	1.51	1.19	0.73	0.41	0.48	1.24	2.22	3.82	21.83	
	Max	13.02	8.86	7.18	6.12	3.02	4.07	2.24	1.44	5.55	5.82	14.52	14.52	
	Min	NA	NA	NA	NA	NA	NA	NA	NA	NA	NA	NA	NA	NA

Northeast
 Mountain
 Zone

Interior
 Mountain
 Zone

Table 3.5-2
 Susanville District
 Maximum Monthly Snowfall

Station	Jan	Feb	Mar	Apr	May	Jun	Jul	Aug	Sep	Oct	Nov	Dec	Annual
Fort Bidwell	43.5	26.0	34.0	22.0	6.0	0.0	0.0	0.0	0.0	11.0	16.0	35.0	43.5
Hat Creek	48.9	23.0	22.0	8.0	2.0	0.0	0.0	0.0	3.0	0.5	14.0	25.5	48.9
Quincy	90.3	58.5	45.0	14.0	6.0	1.0	0.0	0.0	0.0	0.0	14.0	49.5	90.3
Boca	92.0	69.0	93.0	37.3	11.0	1.0	0.0	0.0	2.0	12.5	20.0	71.0	93.0

Period of Record: 1951-1976

Table 3.5-3

Mean Snow Depth and Water Content (WC) in Inches at Selected River-Snow Basin Stations in the Susanville District

Basin	Course #	Lat.		Long.		Max. Annual		Jan.		Feb.		Mar.		Apr.		May		# Years Depth WC	Elevation In Feet	
		Deg.	Min.	Deg.	Min.	Depth	WC	Depth	WC	Depth	WC	Depth	WC	Depth	WC	Depth	WC			
Central* Valley (3)	28	41	9.0	120	15.0	28.4	12.1	NA	NA	NA	NA	NA	NA	28.4	12.1	NA	NA	38	6800	
	29	41	15.3	120	13.8	41.9	15.3	NA	NA	NA	NA	NA	NA	41.9	15.3	NA	NA	48	7200	
	30	41	35.0	120	18.2	48.1	17.3	NA	NA	35.4	10.2	41.9	13.0	44.9	16.4	28.7	11.2	48	7100	
	31	40	45.7	121	11.5	23.5	8.6	NA	NA	NA	NA	NA	NA	21.9	8.0	NA	NA	28	6700	
	35	41	14.0	120	47.0	38.5	13.9	NA	NA	28.2	8.2	33.9	10.8	34.0	13.0	12.9	4.8	47	6350	
	39	40	45.0	121	16.0	14.3	5.3	NA	NA	NA	NA	NA	NA	7.8	2.9	NA	NA	6	5900	
	361	40	8.4	120	42.9	67.2	26.2	28.6	8.9	50.0	17.5	57.5	21.8	57.1	23.7	43.0	19.4	13	7300	
	48	40	14.6	121	2.1	65.5	24.5	24.5	6.5	42.4	13.9	58.0	20.0	62.5	24.8	56.8	24.2	48	7100	
	359	39	55.0	120	38.7	89.9	32.6	39.2	11.2	68.8	22.2	75.9	26.5	76.7	30.8	55.5	25.2	13	6900	
	279	39	45.3	120	43.2	107.7	45.9	45.9	NA	NA	72.7	25.7	89.5	36.1	97.5	43.0	70.7	34.9	30	6800
	388	39	47.2	232	52.3	86.8	41.5	41.5	NA	NA	17.0	5.0	NA	NA	86.8	41.5	NA	NA	6	6800
	75	39	40.9	120	37.4	74.6	31.8	31.8	13.0	4.0	31.5	10.5	47.3	16.0	74.3	31.2	59.0	29.2	45	6700
	360	40	2.5	120	52.7	84.6	32.2	41.9	12.3	62.2	21.2	72.1	26.7	72.5	30.1	52.2	23.7	13	6700	
	280	40	0.8	120	17.6	52.1	17.9	29.0	7.2	42.9	12.1	48.1	14.4	46.9	17.1	33.4	13.4	27	6700	
	53	39	58.4	121	12.8	97.4	39.8	40.2	12.0	62.6	20.1	83.6	30.6	94.3	38.6	60.5	28.3	47	6250	
	52	39	45.7	120	42.8	87.8	34.6	39.0	5.0	58.6	20.2	75.0	28.2	76.6	32.7	46.1	21.9	39	6200	
	51	40	25.1	121	16.2	72.2	28.1	30.2	8.4	46.6	14.3	66.6	22.2	69.5	27.9	52.9	23.9	48	6200	
	290	40	15.5	121	2.8	49.5	16.7	23.0	6.5	32.9	10.0	42.1	13.6	42.5	15.5	29.3	11.8	26	6050	
	54	39	56.5	121	11.4	94.3	38.3	34.0	10.4	54.5	18.0	83.9	30.0	94.3	38.4	61.1	27.0	48	5900	
	387	40	22.5	120	52.3	28.0	9.3	NA	NA	NA	NA	NA	NA	NA	4.7	26.0	11.0	3	5850	
	50	40	21.7	120	52.0	27.7	10.0	10.0	NA	19.4	5.6	27.8	9.3	20.2	7.8	32.5	15.5	42	5800	
	355	39	57.3	120	32.3	38.8	12.0	22.7	5.5	30.8	8.9	31.6	10.5	24.9	9.5	8.1	3.5	15	5650	
	354	40	9.3	120	32.5	25.8	7.7	14.9	3.9	21.5	6.1	21.1	6.5	10.4	3.9	2.6	0.9	15	5650	
	49	39	51.4	121	15.8	114.0	52.1	43.8	15.4	66.6	26.1	90.5	38.6	106.4	49.2	83.1	41.3	38	5600	
	55	40	17.6	121	17.5	46.7	16.6	19.0	5.0	33.8	9.9	43.0	14.4	43.1	16.2	32.6	13.4	47	5600	
	56	39	54.0	121	15.4	67.7	27.2	27.2	NA	40.2	14.4	58.7	22.7	54.3	23.3	34.8	16.2	40	5400	
	58	40	21.3	121	25.3	59.1	23.4	22.3	5.8	36.5	11.1	52.0	18.5	54.8	22.2	45.4	19.9	48	5400	
	59	40	23.2	121	18.6	43.3	16.5	7.5	1.0	33.2	10.2	39.9	13.9	37.7	15.3	25.0	11.5	46	5100	
	60	40	11.2	121	17.9	34.7	12.8	13.0	3.0	23.6	6.8	34.1	11.4	28.0	11.0	17.0	7.0	46	4850	
	61	40	17.0	121	15.0	28.8	10.0	15.6	3.4	23.1	7.3	27.3	9.4	18.2	7.1	9.3	3.6	45	4600	
	Lahontan Area	378	41	57.9	120	11.1	68.3	25.5	NA	NA	NA	NA	55.0	16.8	65.8	25.5	NA	NA	8	7200
		313	41	14.1	120	7.5	35.3	11.5	NA	NA	27.2	7.4	31.3	9.8	30.2	10.8	NA	NA	20	6500
		349	41	16.5	119	53.5	13.9	3.9	NA	NA	9.2	2.1	10.5	2.8	7.7	2.4	NA	NA	19	6400
		393	41	57.0	120	11.5	50.3	16.5	NA	NA	NA	NA	44.5	13.3	46.5	16.5	NA	NA	4	6200
		350	41	31.5	119	52.0	15.9	4.1	NA	NA	10.7	2.4	13.0	3.2	7.8	2.4	NA	NA	19	6000
		314	41	52.5	120	12.1	34.9	11.0	NA	NA	26.6	7.2	30.2	9.5	28.4	10.4	NA	NA	20	5900
		45	41	29.8	121	9.2	70.1	30.1	NA	NA	40.8	11.0	46.8	16.3	68.7	29.1	43.2	21.5	38	6450
		46	40	28.9	121	0.4	40.6	16.3	NA	NA	25.3	7.2	31.2	10.7	39.3	15.9	12.7	5.5	38	5700
		334	39	21.0	119	52.0	78.7	32.6	41.5	9.5	18.5	5.0	54.3	16.7	78.4	32.5	36.3	18.7	66	9000
		392	39	21.1	119	53.9	105.6	40.8	55.7	15.0	78.3	26.3	92.4	33.0	97.8	38.0	86.4	38.3	8	8850
		86	39	25.5	120	19.0	109.7	43.3	28.3	5.3	60.3	20.3	86.1	31.2	103.5	41.3	101.1	43.8	41	8450
		64	39	29.0	120	26.4	107.1	43.2	NA	NA	NA	NA	128.5	48.0	104.0	41.9	161.0	71.0	55	7800
		318	39	11.3	120	14.9	123.7	48.7	48.7	6.0	89.4	32.2	106.9	40.9	120.1	49.0	112.1	51.4	24	7700
		88	39	27.0	120	17.5	62.3	23.6	24.7	6.9	48.3	15.1	51.7	18.1	56.5	22.8	38.8	17.5	37	7000
		89	39	29.1	120	25.5	77.9	30.3	NA	NA	NA	NA	104.0	37.5	76.6	29.8	113.7	38.0	53	7000
	91	39	29.5	120	16.9	41.0	14.3	3.0	3.3	28.9	8.8	35.2	11.7	34.0	13.0	17.6	7.0	41	6500	
	90	39	22.5	120	14.0	55.4	19.4	16.0	3.3	41.1	12.5	48.6	15.9	46.6	18.0	34.4	14.1	41	6500	
	92	39	18.0	120	12.0	48.7	17.4	36.0	9.7	33.7	9.6	48.2	14.7	39.7	15.0	83.5	36.0	47	6400	
	342	39	19.2	120	14.7	52.6	16.8	NA	NA	36.7	10.6	45.8	14.3	43.3	16.1	NA	NA	19	6000	
	95	39	22.5	120	5.5	25.0	8.0	32.0	9.0	19.3	5.2	21.7	6.9	12.0	4.5	32.0	15.0	40	5900	

Period of Record: 1931 - 1975

*River Basin Number

STATE OF CALIFORNIA
 THE RESOURCES AGENCY OF CALIFORNIA
 DEPARTMENT OF WATER RESOURCES
 DIVISION OF FLOOD MANAGEMENT
 CALIFORNIA COOPERATIVE SNOW SURVEYS
INDEX TO BASIN MAPS
1978

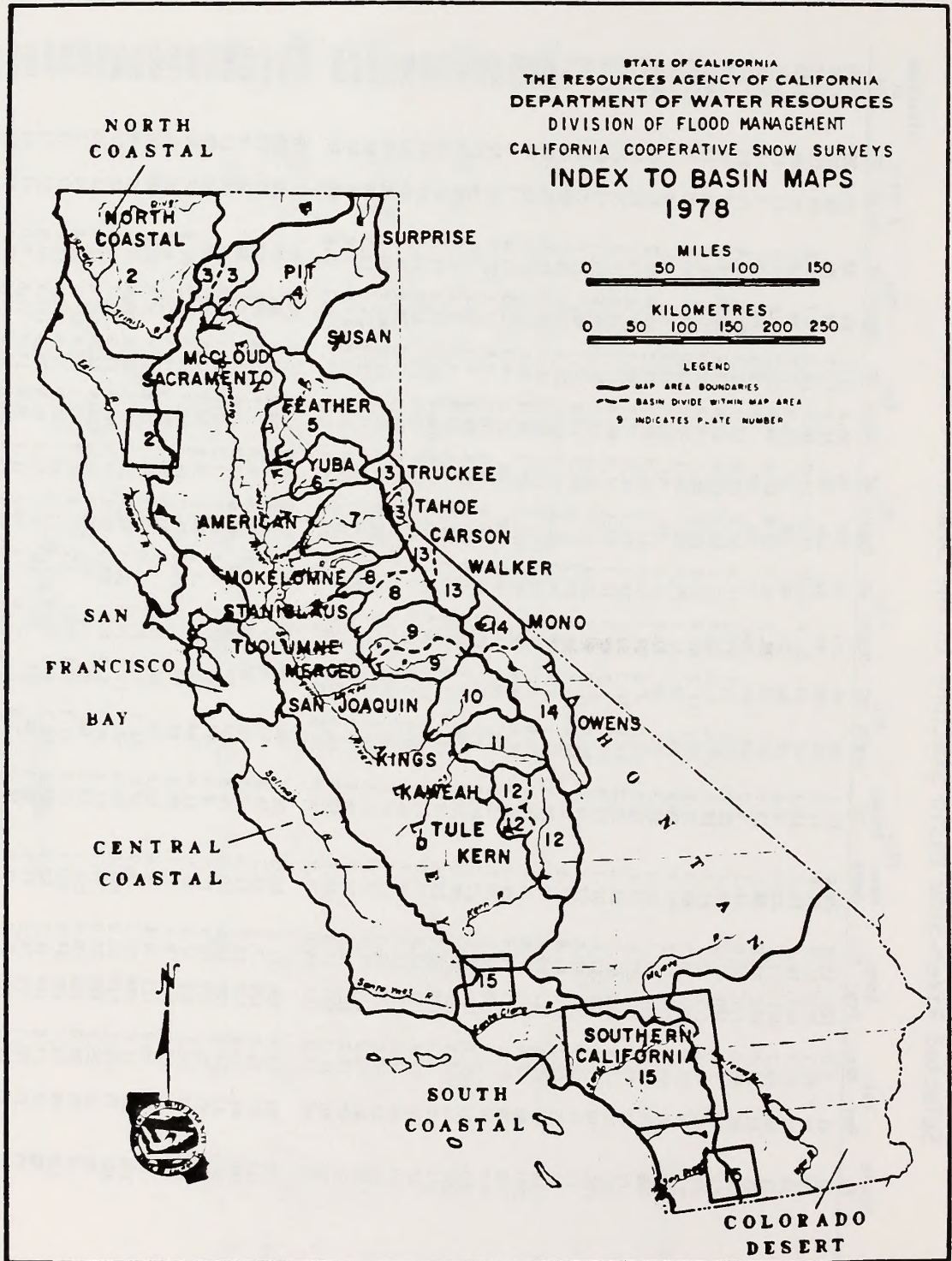

Figure 3.5-3
 Snow Basin Map

precipitation and rainfall in a given region. Isopluvial maps facilitate an evaluation of rainfall intensity for particular areas over selected short-term time periods or intervals. Isohyet analyses coupled with isopluvial studies provide an indication of the nature of the precipitation means for the area, i.e., frequent light rains versus sporadic heavy rainstorms.

Appendix A provides isopluvial analyses for the Susanville District as well as for the entire state of California. These figures provide information for the following return periods and rainfall duration times:

- o 2 year-6 hour precipitation
- o 5 year-6 hour precipitation
- o 10 year-6 hour precipitation
- o 25 year-6 hour precipitation
- o 50 year-6 hour precipitation
- o 100 year-6 hour precipitation
- o 2 year-24 hour precipitation
- o 5 year-24 hour precipitation
- o 10 year-24 hour precipitation
- o 25 year-24 hour precipitation
- o 50 year-24 hour precipitation
- o 100 year-24 hour precipitation

These maps present precipitation amounts received within designated time periods based on recurrence intervals of 2, 5, 10, 25, 50 or 100 years. For example, Figure A-1 provides isopluvials of precipitation amounts for a 6 hour period, experienced at least once in a 2 year time frame. The isoline intervals provided on these maps were designed to provide a reasonably complete description of isopluvial patterns in various regions of the state. Dashed intermediate lines are placed between the normal isopluvial intervals where a linear interpolation would lead to erroneous results.

Rainfall frequency values for selected key stations within the Susanville District were obtained from the Appendix and summarized in Table 3.5-4. This table provides easy reference to pluvial indices for the climatic zones throughout the District. The tables and figures indicate that more mountainous areas could expect the most intense rainfall amounts over a 6 or 24 hour period. At Quincy, for example, rainfall could total as high as 4 to 6 inches in a single 24 hour period. At lower elevations, 24-hour maxima are quite variable ranging from less than 2 inches at Fort Bidwell, Alturas and Nubieber to over 5 inches at Susanville. Values of 2 to 5 inches are the rule for the 24-hour maximum rainfall over the District. The isopluvial maps, as previously mentioned, strongly reflect the influence of topography on the nature of precipitation as evidenced by the values indicated in Table 3.5-4 for the District's mountainous areas.

Table 3.5-4
 Pluvial Indices (in tenths of inches)
 at Selected Stations in the Susanville District

Time Frame	6 HOUR				24 HOUR			
Return Period	2 YR	10 YR	25 YR	50 YR	2 YR	10 YR	25 YR	50 YR
Station	Northeast Mountain							
Ft. Bidwell	5	11.5	13.6	14.8	15	22.5	26	27.5
Alturas	7.5	11.5	13.5	15	14	22.5	27.5	30
Nubieber	8	12	15	16	16	25	30	32.5
Susanville	11.2	17	20	22	24	37.5	45	53
Quincy	16	22	26	27.5	40	55	66	72
Vinton	9	12	15	17	18	27.5	30	35
	Interior Mountain							
Portola	14	16	20	24	25	40	40	45

Source: "NOAA, Precipitation-Frequency Atlas of the Western United States: California", 1973.

3.6 PREVAILING WINDS

Wind is considered a primary climatic parameter since air flow characteristics directly affect ambient air moisture content and regional temperature levels. Seasonal and diurnal air flow patterns can promote periods of wet or dry weather as well as determine hot or cold climates. The prevailing winds are responsible for much of the climatic characteristics of an area and are deeply interrelated with other climatic parameters. The distribution of wind direction and wind speed are used to categorize this parameter.

Observations of wind direction are usually classified into the 16 cardinal compass directions using either a directional abbreviation or the heading in degrees. The degrees associated with each compass heading are listed in Table 3.6-1. Meteorological convention requires that the compass heading associated with a given wind observation is the direction from which the air is flowing. In other words, north or northerly winds mean that air is moving from north to south.

The following sections will describe wind on both an annual and seasonal basis. A primary tool used to graphically describe the prevailing wind conditions at a given station is known as a wind rose. As described in detail in Section 4.2.1, a wind rose is a plot of the frequency of winds from each of the sixteen cardinal directions. The diagram resembles a compass face with the length of the line drawn for each direction indicating the frequency of occurrence of flow from that direction for the indicated period of record.

3.6.1 Annual Wind Distribution

California lies within the zone of prevailing westerly winds and is situated on the east side of the Eastern Pacific semi-permanent high pressure center. Since general air flow patterns in the Northern Hemisphere are clockwise (anticyclonic) about high pressure centers, basic air flow over California is from the west and northwest. Figure 3.6-1 illustrates a typical pressure situation off the California coast and depicts the associated wind flow patterns. As the seasons progress, there exists considerable variation in this generalized scheme due to mesoscale (several hundred miles) and synoptic (thousands of miles) scale pressure distribution changes. Most importantly, several mountain chains within the state are responsible for deflecting the large scale flow. Except along the immediate coast, wind direction and speed is likely to be largely a function of local terrain and orographic effects rather than the prevailing circulation patterns observed in a hemispheric sense.

Figure 3.6-2 depicts various selected station locations in and near the Susanville District for which reduced historical wind speed and direction data have been summarized. Annual wind roses are superimposed on this study map for selected key sta-

Table 3.6-1
Wind Direction Classification

Direction (Abbreviation)	Direction (Degrees)	Direction (Winds From)
N	348.75 - 11.25	North
NNE	11.25 - 33.75	North - Northeast
NE	33.75 - 56.25	Northeast
ENE	56.25 - 78.75	East - Northeast
E	78.75 - 101.25	East
ESE	101.25 - 123.75	East - Southeast
SE	123.75 - 146.25	Southeast
SSE	146.25 - 168.75	South - Southeast
S	168.75 - 191.25	South
SSW	191.25 - 213.75	South - Southwest
SW	213.75 - 236.25	Southwest
WSW	236.25 - 258.75	West - Southwest
W	258.75 - 281.25	West
WNW	281.25 - 303.75	West - Northwest
NW	303.75 - 326.25	Northwest
NNW	326.25 - 348.75	North - Northwest

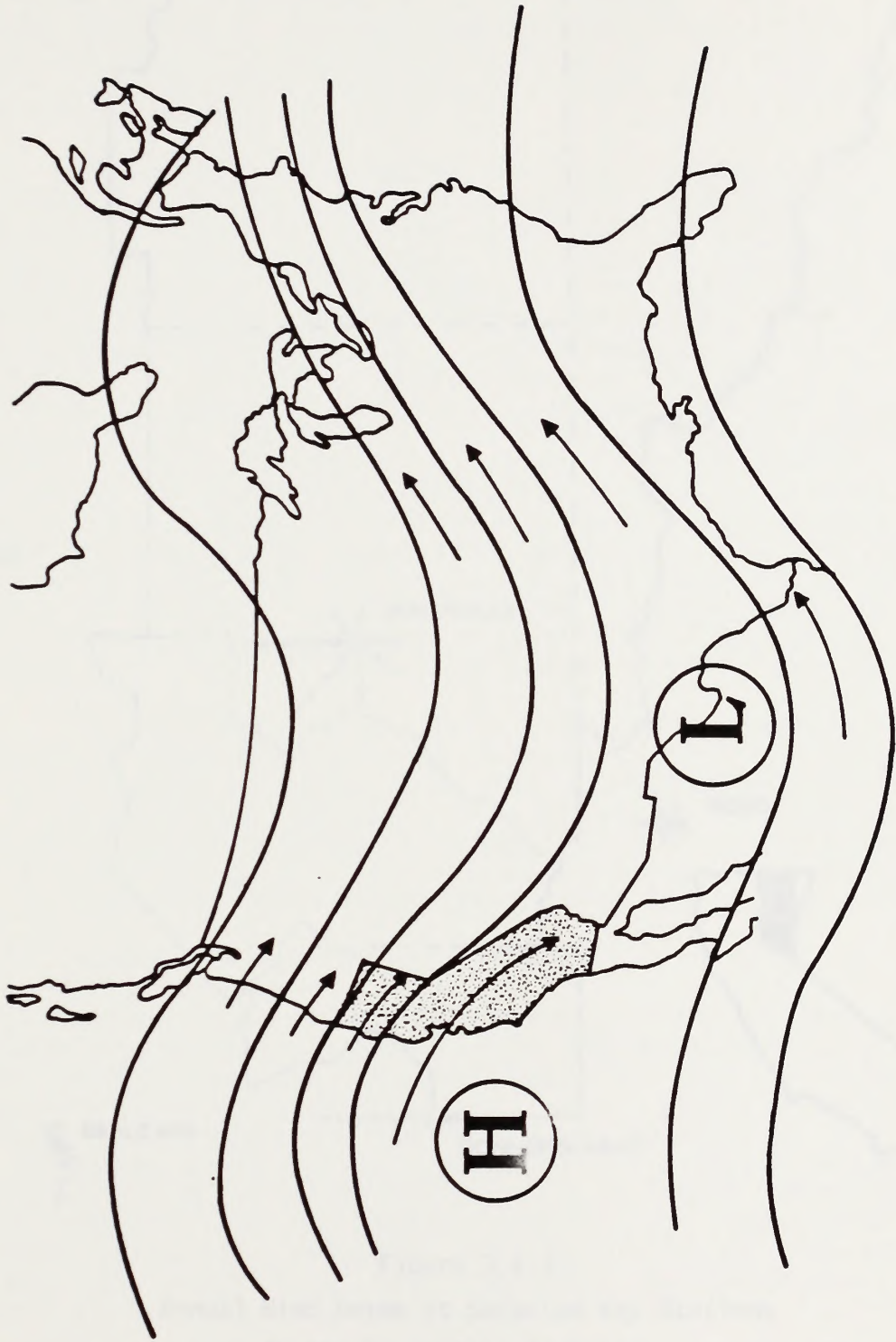

Figure 3.6-1
Prevailing Synoptic Scale Wind Flow Patterns Over California

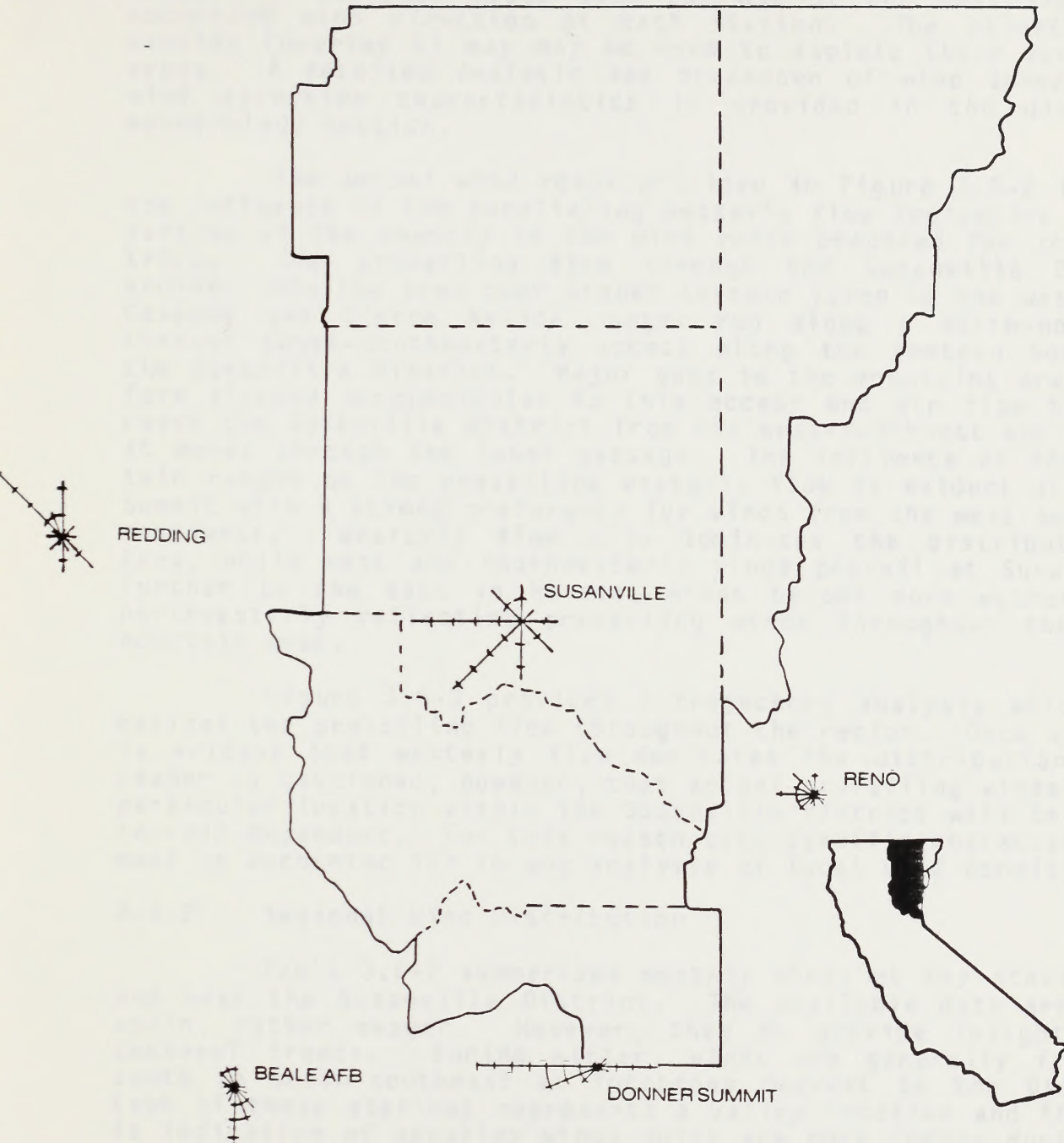

Figure 3.6-2
Annual Wind Roses at Selected Key Stations
in the Susanville District

Note: Each Division on the Roses is Equal to an Annual Frequency of 5%.

tions within each climatic zone in the district coupled with a trajectory analyses based upon the use of the most frequently occurring wind direction at each station. The climatic zone overlay (Overlay C) map may be used to isolate these particular areas. A detailed analysis and breakdown of wind speed versus wind direction characteristics is provided in the dispersion meteorology section.

The annual wind roses provided in Figure 3.6-2 indicate the influence of the paralleling westerly flow indicative of this portion of the country in the wind roses prepared for this District. The prevailing flow through the Susanville District arrives into the area over higher terrain lying to the west. The Cascade and Sierra Nevada ranges run along a north-northwest through south-southeasterly access along the western border of the Susanville District. Major gaps in the mountains are therefore aligned perpendicular to this access and air flow tends to reach the Susanville District from the west-southwest and west as it moves through the lower passage. The influence of the mountain ranges on the prevailing westerly flow is evident at Donner Summit with a strong preference for winds from the west and west-southwest. Westerly flow also dominates the distribution at Reno, while west and southwesterly winds prevail at Susanville. Further to the east in Nevada, winds become more westerly and northwesterly reflecting prevailing winds throughout the inner mountain west.

Figure 3.6-3 provides a trajectory analysis which summarizes the prevailing flow throughout the region. Once again it is evident that westerly flow dominates the distribution. The reader is cautioned, however, that actual prevailing winds at any particular location within the Susanville District will be highly terrain dependent. For this reason site-specific characteristics must be accounted for in any analysis of local wind conditions.

3.6.2 Seasonal Wind Distribution

Table 3.6-2 summarizes monthly winds at key stations in and near the Susanville District. The available data are, once again, rather meager. However, they do provide insights into seasonal trends. During winter, winds are generally from the south to south-southeast at locations nearest to the District. Each of these stations represents a valley location and the flow is indicative of upvalley winds which are more common during the summer season. The increased frequency of winds from the south at these stations reflects the influence of migratory storm systems, as winds from the south and southeast are common in advance of low pressure and frontal systems.

During summer, the indicated trend continues at Red Bluff and Beale AFB, with southerly and southeasterly flow, indicative of upvalley conditions as the maritime sea breeze enters the Central Valley of California at San Francisco and moves northward into the Sacramento Valley and southward into the

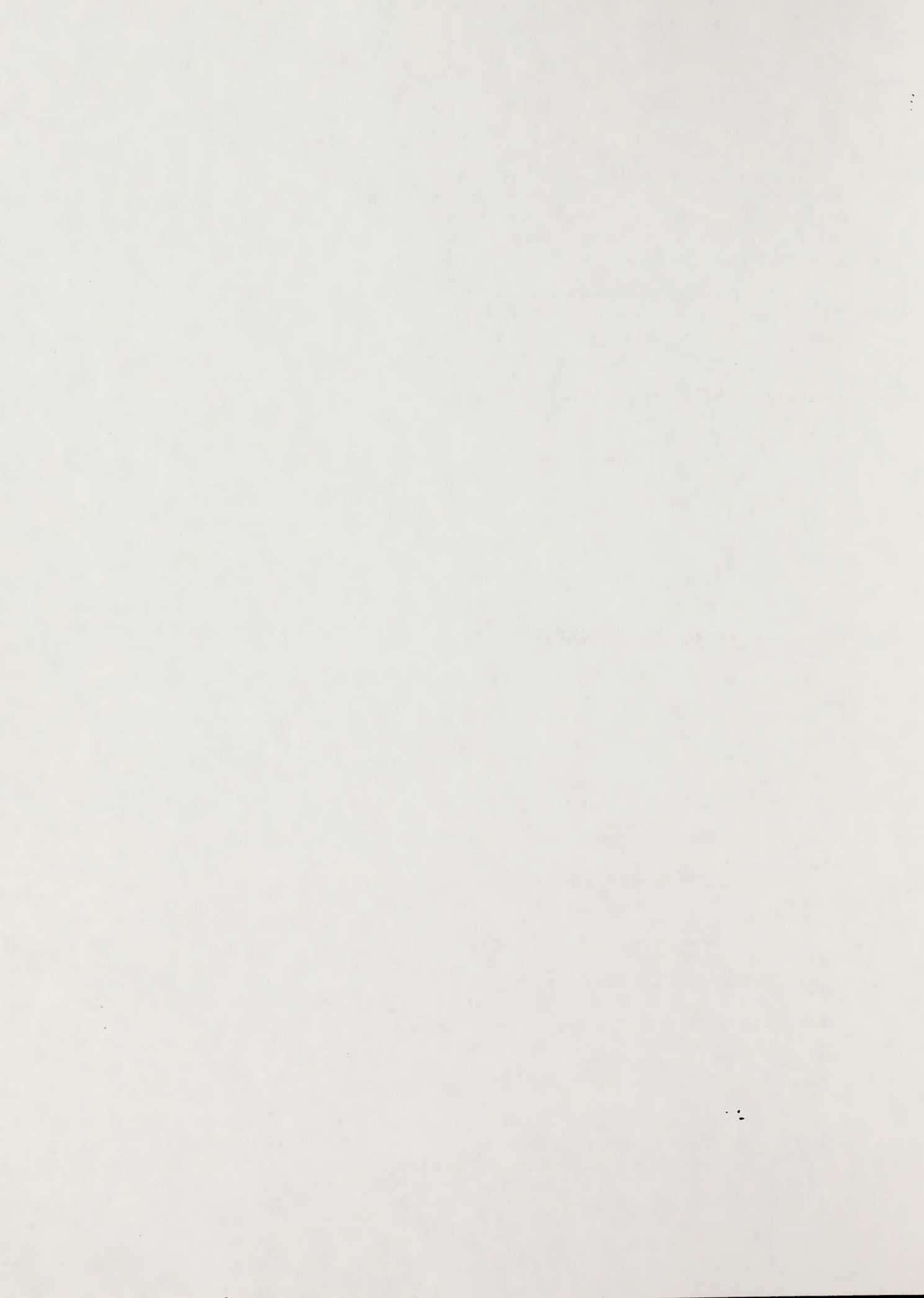

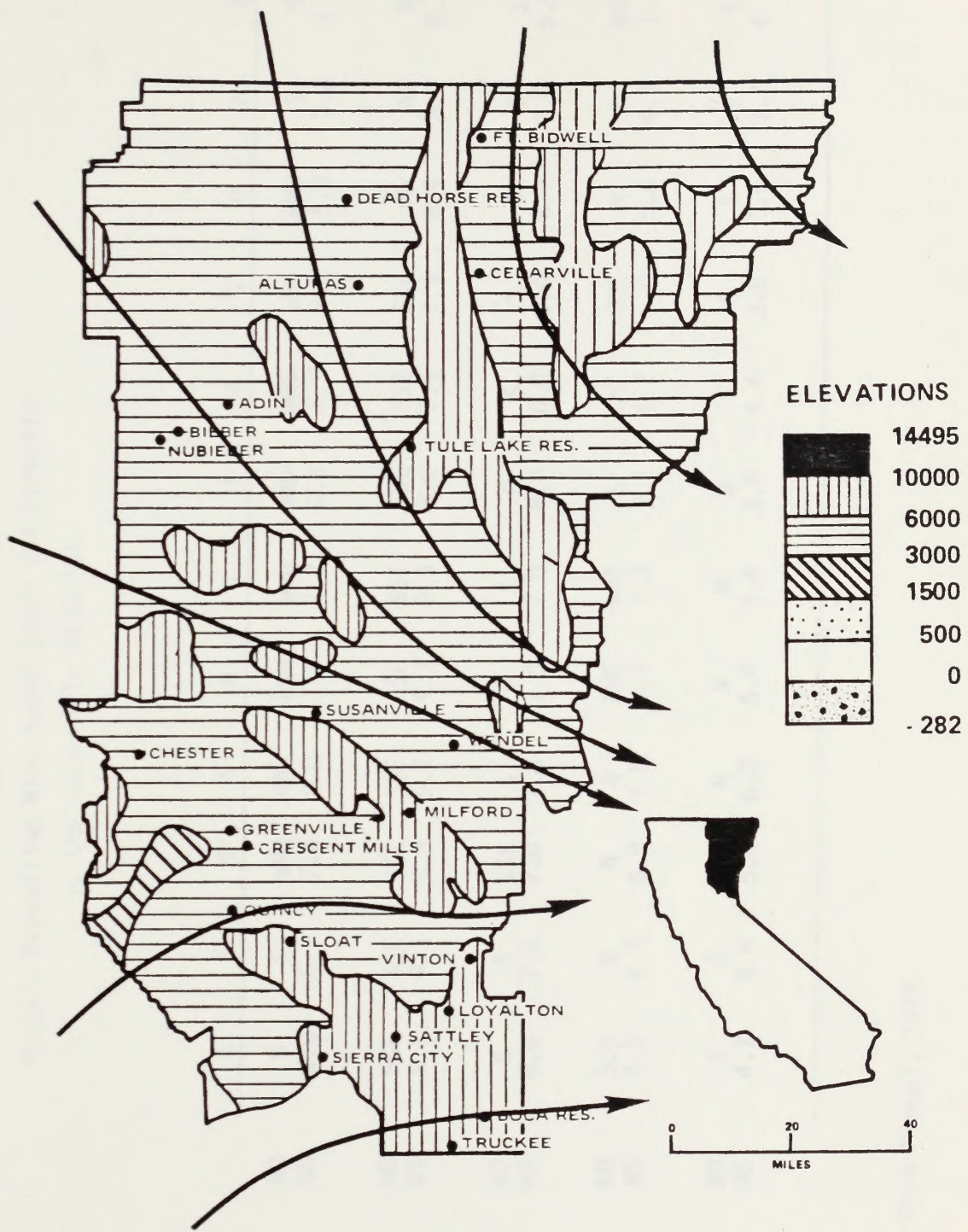

Figure 3.6-3
Annual Trajectory Analysis
for the Susanville District

Table 3.6-2
 Monthly Prevailing Wind Speed (mph) and Direction
 in the Susanville District

	J	F	M	A	M	J	J	A	S	O	N	D
* Reno	WD	S	WNW	WNW	WNW	WNW	WNW	WNW	WNW	WNW	S	SW
	WS	6.0	6.1	7.6	8.0	7.6	7.2	6.6	5.4	5.3	5.3	5.1
Red Bluff (1945-1976)	WD	SSE	SSE	SSE	SSE	SSE	SSE	SSE	SSE	NW	NW	NW
	WS	9.1	9.3	9.9	9.7	9.3	9.3	8.0	7.9	8.4	8.5	8.4
* Beale AFB	WD	S	S	SSE	S	S	S	S	S	S	S	S
	WS	6.0	7.0	7.0	7.0	7.0	7.0	6.0	6.0	6.0	5.0	6.0
Lovelock (1966-1970)	WD	SSW	N	N	N	NNE	NNE	NNE	NNE	N	N	NNE
	WS	4.5	4.7	6.9	7.8	7.7	7.3	7.1	6.0	5.4	4.1	4.4
Fallon (1966-1970)	WD	S	S	S	N	W	W	S	S	S	S	S
	WS	4.7	4.4	5.8	6.3	5.8	5.4	3.6	3.9	3.6	3.7	4.1

* California Star Data Manual, 1978.

San Joaquin Valley. North through westerly flow is prevalent at the more eastern locations during the summer, indicative of regional trends observed during the season in response to flow around the semi-permanent eastern Pacific high pressure system.

North through west-northwesterly flow is observed at Red Bluff, Reno and Lovelock during the fall months which is typical throughout most of California during the season. The primary direction remains southerly at Beale AFB and Fallon, being relatively close to the point of entry for the maritime sea breeze at San Francisco and Oakland.

Wind speeds are strongest during spring at all locations, with Red Bluff recording the highest speed of 9.9 mph during March. Minimum speeds generally occur during late summer and fall. These are periods of atmospheric stagnation throughout much of California, as wind speeds become light and variable under the influence of the semi-permanent eastern Pacific high pressure system. The ventilation potential is poorest during this season and high pollutant levels can more readily occur.

3.7 EVAPORATION AND RELATED PARAMETERS

Evaporation is the physical process by which water is transformed from the liquid to the gaseous state. The rate of evaporation in a particular region is dependent upon many climatic parameters, but is primarily influenced by wind, temperature, relative humidity, sky conditions, precipitation and solar radiation.

Evapotranspiration is the process whereby water vapor is returned to the atmosphere both by living plants (transpiration) and from the earth's surface (evaporation). An assessment of regional evapotranspiration is important to the water and agricultural industries as it provides a complete picture of natural water demand for a given geographical area.

Solar radiation is the earth's principle source of energy. This energy is naturally dispersed in numerous forms such that much of the received solar energy is used to generate winds, heat air masses, as well as supply latent heat energy to the atmosphere by contributing to the rate of evaporation of large quantities of water into the atmosphere. Consequently, mean monthly and annual solar radiation levels for particular locations are often expressed in terms of equivalent evaporation units. The standard conversion of solar radiation units, as expressed in Langleys, to inches of evaporation, requires that 1 inch of evaporation be equivalent to 1486 Langleys.

3.7.1 Evaporation and Evapotranspiration

The California State Department of Water Resources has determined regional evaporative demand areas on the basis of similar monthly levels of evaporation and evapotranspiration rates. These areas are provided in Figure 3.7-1 for the entire state of California.

The Susanville District includes two of the eleven statewide zones of similar evaporative demand. The Nevada portion of the District is assumed to be represented by zone #3. A contour map depicting areas of equal annual evaporative demand levels for the Susanville District is provided as Figure 3.7-2. Note that considerable gradients of evaporative demand exist between the more mountainous terrain in the western portion of the District in contrast to the dry portions of Northwestern Nevada.

A comparison of annually averaged evaporative demand and evapotranspiration rates for different geographical areas can lead to ambiguous results. Annual evaporative totals for two areas may be similar, but monthly patterns of evaporation and evapotranspiration may differ significantly. Monthly tabulations of average pan evaporation rates and estimated potential evapotranspiration rates for the various California climatic regions are presented in Table 3.7-1.

ZONES OF SIMILAR EVAPORATIVE DEMAND IN CALIFORNIA

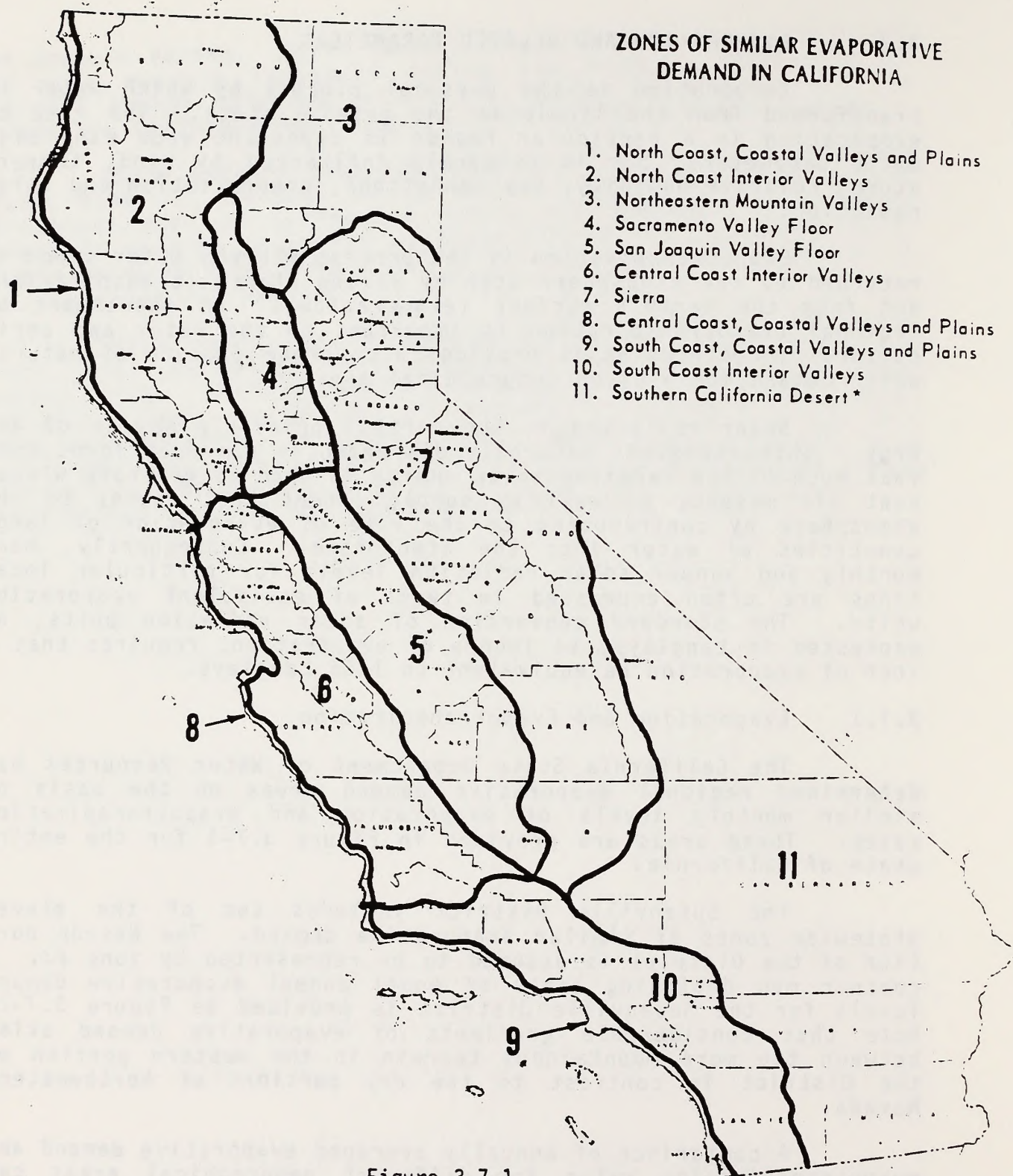

Figure 3.7-1

*Reliable Data on evaporative demand is generally unavailable in the Southern California Desert. Studies by other agencies are in progress in Imperial Valley and Palo Verde Valley (Zone 11)

Source: "Vegetative Water Use in California, 1974", State of California Department of Water Resources

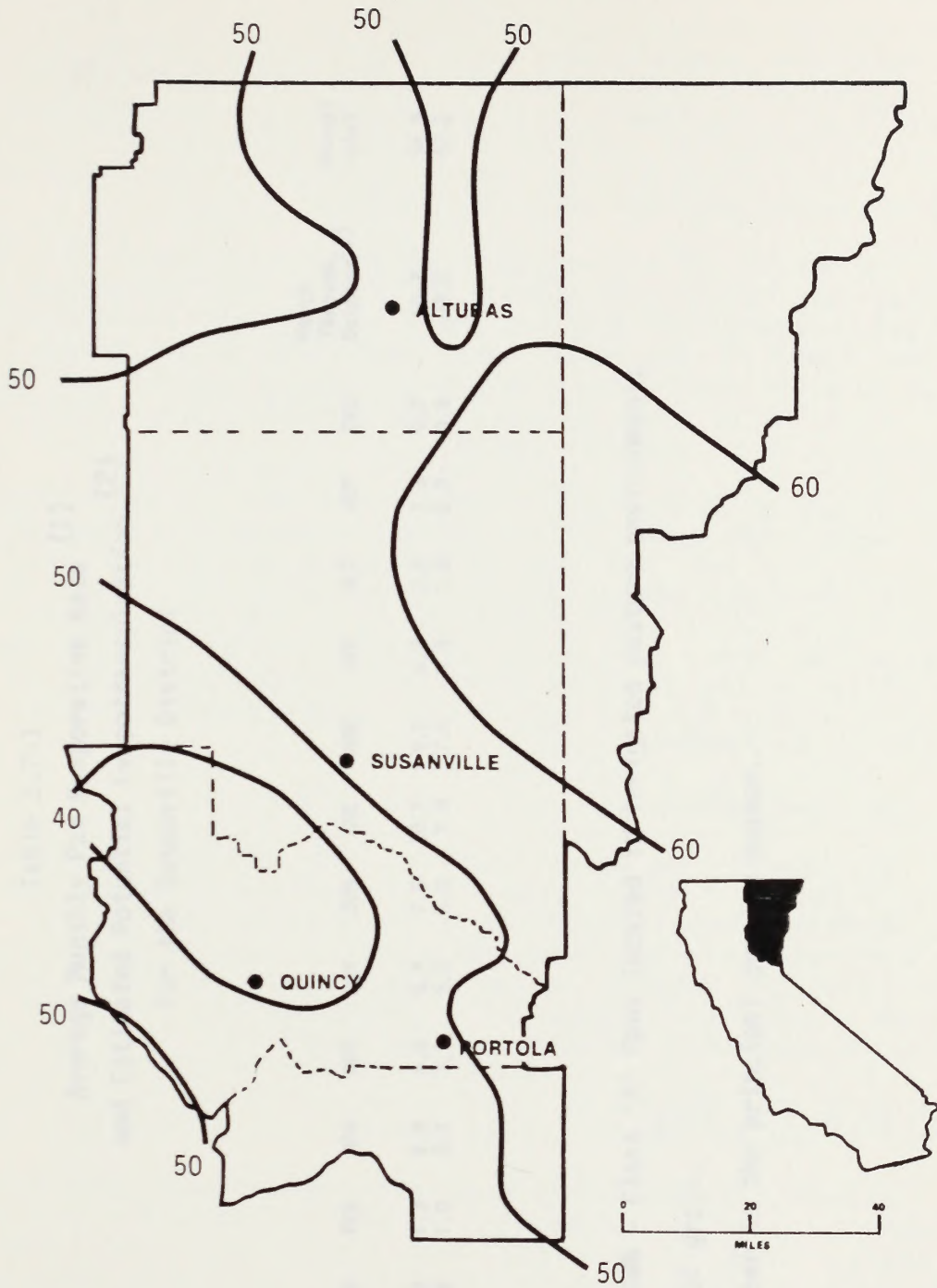

Figure 3.7-2
Annual Evaporative Demand
in the Susanville District

Estimated from evaporation observed in non-irrigated environments adjusted to appropriate evaporation from Class "A" pans in irrigated pasture environments.

Source: State of California, "Vegetative Water Use in California, 1974"

Table 3.7-1
 Average Monthly Pan Evaporation Rate (1)
 and Estimated Potential Evapotranspiration (2)
 for the Susanville District

Evaporation Region	JAN	FEB	MAR	APR	MAY	JUN	JUL	AUG	SEP	OCT	NOV	DEC	March Through October (3)	Annual Total
Northeastern Mountain Valleys	0.8	1.3	2.8	4.8	6.4	7.5	10.1	9.0	6.3	3.8	1.3	0.7	50.7	54.8
(3)	0.6	1.0	2.1	3.7	5.0	5.8	7.9	7.0	4.9	2.8	0.9	0.5	39.2	42.2

(1) Evaporation from USWB - Class "A" Pans located in irrigated pasture environment.

(2) Potential ET = ET of grass.

(3) March through October is the principal growing season.

Maximum evaporation rates generally occur in July. During this month in all climatic regions, the incident of solar radiation is at a maximum. Average monthly pan evaporation rates range from 10 inches in July to a winter minimum of 0.7 inches in December. The growing season (March through October) average pan evaporation rates average about 51 inches.

The ratio of evapotranspiration to evaporation (ET/Ep) is obtained empirically by simply observing and comparing simultaneous pan evaporation and net water loss from vegetation soil tanks (the tank is designed such that all water added to the apparatus and all water left after a testing period can be measured). This ratio thus allows a more definitive evaluation of water demand in a particular region.

Since evapotranspiration values are so dependent upon crop and vegetation type, it is useful to observe ET/Ep ratios on a monthly basis for the entire growing season of particular crops. In general, potential evapotranspiration values as presented in Table 3.7-1 are determined by using grass as the standard vegetation type. Table 3.7-2 provides a summary of observed monthly ET/Ep ratios for the principle irrigated crops in California as provided by the California State Water Resources Control Board in Sacramento.

3.7.2 Sky Conditions

Sky cover is a measure of the degree of cloudiness characteristic of a given area for a certain time period. Sky cover conditions experienced in a particular region are interrelated with the mean incoming solar radiation, mean temperature, and precipitation levels, as well as having numerous secondary effects on many other climatic parameters, all of which effect the local evaporative demand. In addition, as discussed in Section 4.2-2, sky cover has an application to dispersion meteorology through its impact on insolation, and thus is an important parameter in the determination of atmospheric stability.

Clouds substantially insulate the surface from receiving large quantities of solar energy. Reflection and scattering of light energy from cloud tops and cloud interiors contribute significantly to the overall reduction of light received at ground level. Generally, cloud cover is classified according to various categories. These categories include clear or cloudless sky conditions, mostly clear skies, partly cloudy conditions, mostly cloudy and cloudy conditions, or completely overcast skies. In order to make sky cover observations more definitive, these observations are defined in terms of categories using fractional units expressed in tenths of the sky covered by clouds (See Table 3.7-3).

Table 3.7-2
Summary of Observed Monthly ET/Ep Ratios for Principal
Irrigated Crops 1/

Crop	Location	Observer	Year	Active Growing Season	Jan	Feb	Mar	Apr	May	Jun	Jul	Aug	Sep	Oct	Nov	Dec	Growing Season Average		
<u>Alfalfa (Hay)</u>	Arvin 2.5NW	DWR	1959	Mar-Oct	-	-	-	0.64	0.52	0.64	0.63	0.70	0.90	0.71	1.04	1.12	-		
			1960	"	-	-	-	-	-	0.77	0.64	0.81	0.67	0.63	-	-	-	-	
			1963	"	1.00	0.88	0.72	0.73	0.78	0.73	0.73	0.86	0.90	0.85	0.91	0.70	1.00	0.81	
			Average	"	1.00	0.88	0.72	0.69	0.64	0.71	0.71	0.86	0.90	0.81	0.81	0.75	0.88	1.17	0.73
			1960	Apr-Sep	-	-	-	-	-	0.64	0.81	0.97	0.86	0.95	-	-	-	-	-
			1961	"	-	-	0.28	0.83	0.87	0.77	-	0.86	0.85	0.51	0.33	0.14	-	-	-
			1962	"	-	-	-	0.74	0.92	0.72	0.61	0.61	1.06	-	-	-	-	-	0.75
<u>Barley</u>	Davis 2W (Grain Crop)	U.C.	1969-70	Nov-May	0.70	0.95	0.72	0.64	0.25	-	-	-	-	-	-	0.27	0.50	0.52	
			1972	Feb-May	-	0.48	1.22	0.83	0.18	-	-	-	-	-	-	-	-	-	0.62
			1966-67	Oct-Dec	-	-	-	-	-	-	-	-	-	-	-	0.12	0.90	0.95	0.46
			1968	Jul-Sep	-	-	-	-	-	-	-	-	0.42	0.85	0.43	-	-	-	0.56
			1970	Mar 25- Jul 10	-	-	-	0.15	0.32	0.86	0.38	-	-	-	-	-	-	-	0.48
<u>Cantaloupes</u>	Arvin 2.5S	DWR	1970	May-Oct	0.49	0.28	0.32	0.06	0.14	0.67	1.01	0.95	0.78	0.69	0.39	0.44	0.71		
<u>Castor Beans</u>	Arvin 2.9NW	DWR	1970	Jun-Sep	-	-	-	-	0.12	0.48	0.89	0.84	0.50	-	-	-	0.62		
<u>Corn (Field)</u>	Davis 2W	U.C.	Average 1970-71		-	-	-	-	-	-	-	-	-	-	-	-	-		

1/ Ratios of observed evapotranspiration to evaporation from Class "A" pans in irrigated pasture, or comparable environments data collected by Department of Water Resources and/or cooperative agencies.
2/ Growing season ratios calculated from seasonal totals of ET and evaporation.

Source: "Vegetative Water Use in California, 1974", State of California Department of Water Resources

Table 3.7-2 (Continued)
 Summary of Observed Monthly ET/Ep Ratios for Principal
 Irrigated Crops 1/

Crop	Location	Observer	Year	Active Growing Season	Jan	Feb	Mar	Apr	May	Jun	Jul	Aug	Sep	Oct	Nov	Dec	Growing Season Average			
Cotton	Arvin 2.5MW (Solid Plant)	DWR	1959	May-Oct	-	-	-	0.19	0.81	1.09	0.91	0.86	0.68	0.08	-	-	0.77			
			1960	"	-	-	0.26	0.14	0.03	0.53	1.07	1.10	0.82	0.24	0.53	0.36	0.66			
			1961	"	0.44	0.54	0.28	0.06	0.14	0.55	0.90	1.05	0.92	0.54	0.29	0.33	0.69			
			Average	0.44	0.54	0.27	0.10	0.13	0.63	1.02	1.01	0.87	0.49	0.26	0.33	0.70				
			1962	May-Oct	0.38	0.32	0.23	0.14	0.08	0.37	0.88	0.92	0.83	0.41	0.14	-	0.59			
			1963	May-Oct	0.06	0.33	0.22	0.28	0.20	0.49	0.91	1.06	0.87	0.76	0.20	0.25	0.70			
			1965	May-Oct	-	-	-	-	0.07	0.15	0.68	0.88	0.62	0.26	0.14	0.26	0.46			
Deciduous Orchard	Arvin 3NNW (Plums)	DWR	1959	Apr-Oct	-	-	-	0.51	0.70	0.69	0.83	0.76	0.42	0.23	0.04	-	0.59			
			1960	"	-	-	-	-	0.82	0.92	0.79	0.77	0.34	0.21	-	-				
			1962	"	0.38	0.68	0.26	0.36	0.59	0.62	0.66	0.48	0.68	0.87	0.91	0.33	0.61			
			1963	"	0.39	0.71	0.56	0.92	0.67	0.61	0.69	0.90	0.94	0.82	0.84	0.38	0.79			
			1964	"	0.53	0.33	-	-	0.57	0.83	0.86	0.95	0.88	0.32	0.60	-	-			
			Average	0.44	0.56	0.42	0.56	0.65	0.66	0.78	0.76	0.74	0.62	0.43	0.43	0.69				
			1971	Jul-Oct	-	-	-	-	-	0.26	0.91	0.82	0.40	-	-	-	0.58			
Grain Sorghum (Milo)	Bakersfield 9W	DWR	1959-65 Average	Mar-Oct	0.50	0.72	0.82	0.75	0.81	0.74	0.82	0.88	0.88	0.90	0.81	0.69	0.82			
			1959-71 Average	"	0.79	0.75	0.70	0.73	0.77	0.78	0.79	0.79	0.74	0.68	0.64	0.73	0.76			
			1959-60 Average	"	0.50	0.51	0.67	0.74	0.76	0.50	0.78	0.76	0.73	0.64	0.53	0.40	0.69			
			1964-66 Average	Apr-Sep	-	-	-	0.70	0.70	0.79	0.74	0.96	0.86	0.76	0.45	-	0.79			
			1963-67 Average	Mar-Oct	0.77	0.81	0.78	0.82	0.78	0.69	0.77	0.85	0.84	0.87	0.87	0.79	0.79			
			1968-70	"	0.44	0.75	0.80	0.69	0.73	0.64	0.75	0.69	0.55	0.67	0.69	0.50	0.69			
			1969-72 Average	"	0.92	0.84	0.74	0.59	0.76	0.62	0.72	0.59	0.71	0.63	0.82	0.82	0.67			
			1963-70	"	0.75	0.79	0.77	0.77	0.71	0.68	0.75	0.82	0.75	0.78	0.82	0.64	0.75			
			1963-68	"	0.78	0.64	0.73	0.89	0.85	0.85	0.81	0.78	0.75	0.70	0.62	0.62	0.81			
			Pasture (Improved) & Grass	Arvin 2.5MW (Grass)	DWR	1959-65 Average	Mar-Oct	0.50	0.72	0.82	0.75	0.81	0.74	0.82	0.88	0.88	0.90	0.81	0.69	0.82
						1959-71 Average	"	0.79	0.75	0.70	0.73	0.77	0.78	0.79	0.79	0.74	0.68	0.64	0.73	0.76
1959-60 Average	"	0.50				0.51	0.67	0.74	0.76	0.50	0.78	0.76	0.73	0.64	0.53	0.40	0.69			
1964-66 Average	Apr-Sep	-				-	-	0.70	0.70	0.79	0.74	0.96	0.86	0.76	0.45	-	0.79			
1963-67 Average	Mar-Oct	0.77				0.81	0.78	0.82	0.78	0.69	0.77	0.85	0.84	0.87	0.87	0.79	0.79			
1968-70	"	0.44				0.75	0.80	0.69	0.73	0.64	0.75	0.69	0.55	0.67	0.69	0.50	0.69			
1969-72 Average	"	0.92				0.84	0.74	0.59	0.76	0.62	0.72	0.59	0.71	0.63	0.82	0.82	0.67			
1963-70	"	0.75				0.79	0.77	0.77	0.71	0.68	0.75	0.82	0.75	0.78	0.82	0.64	0.75			
1963-68	"	0.78				0.64	0.73	0.89	0.85	0.85	0.81	0.78	0.75	0.70	0.62	0.62	0.81			

Table 3.7-2 (Continued)
 Summary of Observed Monthly ET/Ep Ratios for Principal
 Irrigated Crops 1/

Crop	Location	Observer	Year	Active Growing Season	Jan	Feb	Mar	Apr	May	Jun	Jul	Aug	Sep	Oct	Nov	Dec	Growing Season Average		
Pasture (Native) (High Water Table Meadow)	Alturas 2SE	DWR	1959	Apt-Sep	-	-	-	0.94	0.98	1.14	1.06	1.05	0.96	0.78	-	-	1.03		
			1960	-	-	-	0.67	0.81	0.82	1.09	1.12	1.02	0.97	-	1.33	-	-	0.95	
			1961	-	0.17	0.47	0.74	0.78	1.00	1.00	1.19	0.96	1.12	1.00	-	-	-	-	1.02
			1962	-	-	-	0.35	0.72	0.76	0.86	0.96	0.98	0.96	0.98	0.95	0.77	0.69	0.60	0.88
			1963	-	0.42	0.36	0.48	0.59	0.61	0.98	0.81	0.89	0.81	0.89	0.89	0.83	-	-	0.82
			1964	-	-	-	-	0.56	0.66	0.86	0.93	0.99	0.93	0.99	0.89	0.86	-	-	0.85
			Average	-	0.44	0.40	0.56	0.75	0.80	0.94	1.00	1.00	1.00	0.96	0.96	0.85	0.69	0.88	0.93
Pasture (Native) (Continued)	Lookout 3S	DWR	1961	Apt-Sep	0.20	0.30	0.42	0.68	0.82	1.00	0.84	0.97	0.94	0.77	-	-	-	0.88	
			1962	-	-	-	0.69	0.95	0.84	0.87	0.82	0.85	0.70	0.62	0.56	-	-	0.84	
			1963	-	-	0.61	-	0.94	1.06	0.99	1.00	1.15	-	-	-	-	-	-	
			Average	-	0.20	0.30	0.50	0.68	0.88	0.92	0.92	0.92	0.92	0.92	0.86	-	-	0.88	
Potatoes	Arvin 2.8NW	DWR	1966	Apt-Jun	-	-	-	0.91	1.01	0.49	-	-	-	-	-	-	0.87		
			1967	-	-	0.50	0.66	0.90	0.51	0.38	-	-	-	-	-	-	-	0.66	
			Average	-	-	0.50	0.83	0.94	0.49	0.38	-	-	-	-	-	-	-	0.76	
Sugar Beets	Arvin 2.5S Davis 2W	DWR U.C.	1966	Apt-Jul	-	-	-	0.68	1.01	1.02	0.68	-	-	-	-	-	0.86		
			1965	Jul-Oct	-	-	-	-	-	-	0.41	0.92	0.88	0.88	0.88	0.57	-	0.66	
			1966	Apt-Sep	-	-	-	0.17	0.36	0.86	0.93	0.83	0.91	-	-	-	-	0.64	
Tomatoes	Arvin 2.5NW	DWR	1968	Apt-Jul	-	-	-	0.14	0.72	0.70	0.50	-	-	-	-	-	0.53		
			1969	-	-	-	0.35	0.86	0.98	0.82	-	-	-	-	-	-	-	0.78	
			Average	-	-	-	0.25	0.80	0.84	0.76	-	-	-	-	-	-	-	0.64	
Vineyard	Davis 2W Arvin 1NW (Thompson Table Grapes)	U.C. DWR	1969	May-Oct	-	-	-	-	0.22	0.39	0.87	0.90	0.62	-	-	-	0.59		
			1966	-	-	-	-	0.41	0.57	0.79	0.45	0.30	-	-	-	-	-		
			1967	-	-	-	-	-	0.51	0.66	0.79	0.64	0.32	0.04	0.50	-	-		
			1968	-	0.50	0.31	0.16	0.13	0.62	0.68	0.58	0.51	0.65	0.24	0.11	0.42	0.58		
1969	-	0.87	0.20	0.11	0.11	0.35	0.68	0.72	0.65	0.64	0.38	0.12	0.15	0.60					
Average	-	0.62	0.27	0.15	0.12	0.46	0.61	0.67	0.62	0.55	0.32	0.08	0.35	0.56					

Table 3.7-3
Sky Cover Categories

<u>Generalized Category</u>	<u>Sky Cover in Tenths</u>
clear	0
mostly clear	0-3
partly cloudy	4-7
mostly cloudy	8-10
cloudy or complete overcast	10

The mean monthly and annual sky conditions at several stations located near the Susanville District are provided in Figure 3.7-3. Data is available from Red Bluff, Mt. Shasta and Reno, Nevada. Data available for Red Bluff provides an indication of conditions in the western portion of the Susanville District. The data indicate that the highest frequency of cloudy skies occurs during the winter and spring months when 5 to 7 tenths of cloudiness are observed at this station. During the summer and early fall, cloudy skies occur very rarely as the average sky cover drops to near 1 tenth during July and August.

Data indicative of conditions in the Interior Mountain CZ are available from Mt. Shasta. The data reflect the trend observed further to the south in the Sacramento Valley portion of the District. Mean cloudiness reaches a maximum during the winter season and early spring. At Mt. Shasta, the annual mean of 4.8 tenths is only slightly higher than that observed further to the south at Red Bluff. The sky is generally mostly cloudy (6 to 7 tenths) during the winter and early spring months when the influence of migratory storm systems reaches a maximum at this location. Once again, the skies become nearly cloudless during August and September when between 1 and 2 tenths of cloudiness prevails.

Data available for Reno are also presented in Figure 3.7-3 and are felt to be indicative of conditions in the lee of the major Cascade and Sierra Nevada mountain chain and will provide an indication of sky cover conditions in this rainshadow area. The data indicate a maximum frequency of cloudiness during the winter season months when storms and frontal systems frequently pass through the area causing cloudy and overcast conditions. The data indicate that the sky is more than half overcast during the winter season period, November through April. Cloudiness reaches a minimum during the period July through September when the mean sky cover is generally less than 0.3. During the summer months, bright cloudless skies are frequently the rule in the Susanville District and diurnal temperature ranges reach a maximum. The mean annual sky cover for Reno is 4.6. Further to the east at Fallon and Lovelock, Nevada, the mean annual sky cover conditions are further improved.

Table 3.7-4 provides a detailed seasonal and diurnal analyses of the sky cover distribution for nearby Red Bluff and Ukiah. The data indicate that cloudy skies occur most frequently

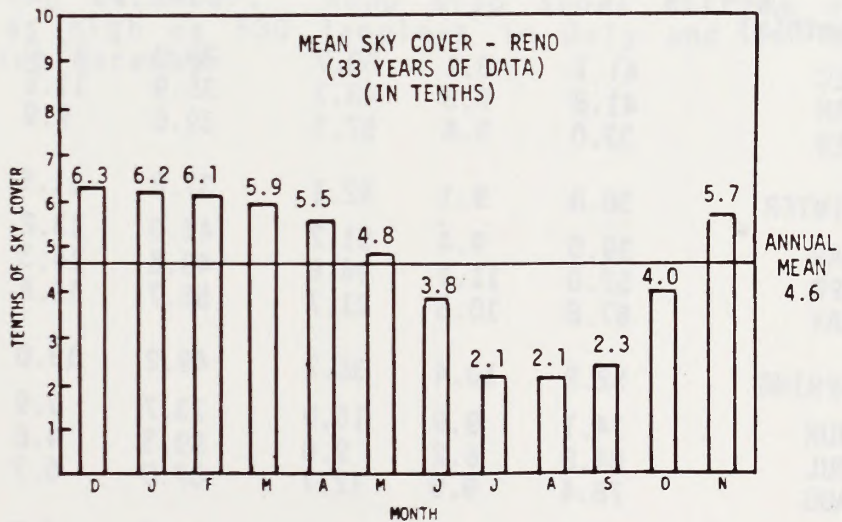
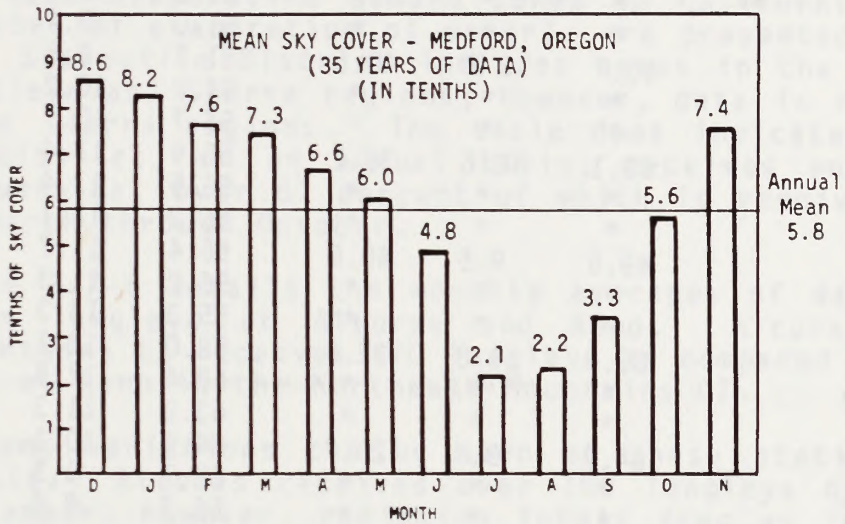
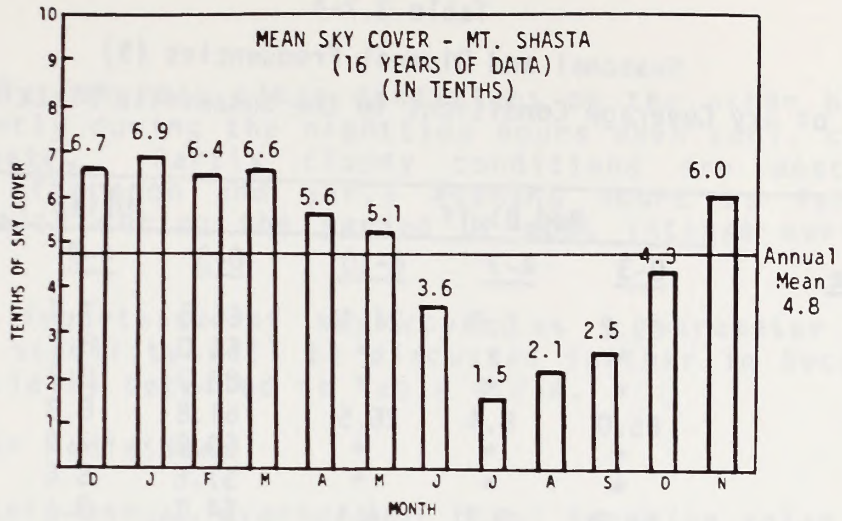

Figure 3.7-3
Interior Mountain Climatic Zone
Monthly and Annual Sky Cover Distribution

Table 3.7-4
 Seasonal and Diurnal Frequencies (%)
 of Sky Coverage Conditions in the Susanville District

Time	Red Bluff			Ukiah		
	0-3	4-7	8-10	0-3	4-7	8-10
01	69.2	6.7	24.1	66.5	7.7	25.8
02	*	*	*	64.0	8.2	27.8
03	*	*	*	62.9	8.7	28.4
04	65.0	8.4	26.5	61.8	8.3	29.9
05	*	*	*	60.8	7.9	31.3
06	*	*	*	57.6	8.6	33.8
07	56.2	9.7	34.1	54.1	9.1	36.8
08	*	*	*	51.5	10.4	38.1
09	*	*	*	51.0	9.4	39.6
10	50.7	8.8	40.5	51.7	9.5	38.7
11	*	*	*	54.2	10.2	35.6
12	*	*	*	55.7	10.7	33.6
13	50.1	10.6	39.2	55.9	11.4	32.7
14	*	*	*	56.5	11.4	32.1
15	*	*	*	56.2	12.1	31.7
16	49.6	9.5	40.8	56.4	11.2	32.4
17	*	*	*	56.2	11.3	32.4
18	*	*	*	55.3	13.3	31.4
19	55.6	11.8	32.5	58.0	12.1	30.0
20	*	*	*	60.4	12.8	26.8
21	*	*	*	63.2	11.3	25.5
22	64.9	9.4	25.7	64.9	10.1	25.0
23	*	*	*	65.7	9.5	24.8
24	*	*	*	66.3	8.4	25.3
Month(s)						
DEC	41.1	8.1	50.7	38.0	13.0	49.0
JAN	41.8	9.5	48.7	35.9	11.5	52.6
FEB	33.0	9.6	57.3	39.6	9.9	50.5
WINTER						
WINTER	38.8	9.1	52.1	37.8	11.5	50.7
MAR	39.0	9.4	51.7	42.0	13.2	44.8
APR	52.0	11.4	36.6	49.8	14.3	36.0
MAY	67.8	10.5	21.7	55.7	11.6	32.7
SPRING						
SPRING	52.9	10.4	36.7	49.2	13.0	37.8
JUN	74.1	9.9	16.0	73.7	9.9	16.5
JUL	84.8	6.2	9.0	89.3	4.8	5.8
AUG	78.4	9.0	12.7	87.0	5.7	7.3
SUMMER						
SUMMER	79.2	8.3	12.5	83.4	6.8	9.8
SEP	79.7	6.3	14.0	81.4	7.0	11.5
OCT	61.9	10.5	27.7	62.7	10.1	27.2
NOV	36.8	12.1	51.2	47.4	10.8	41.8
FALL						
FALL	59.5	9.6	30.9	63.8	9.3	26.9

*No data

during midday, whereas clear conditions on the other hand, occur most frequently during the nighttime hours when cool, calm conditions dominate. Partly cloudy conditions are most frequent during the afternoon and early evening hours as fair weather cumulus develop during the period of most intense surface heating.

The importance of sky cover as a parameter affecting atmospheric stability will be discussed further in Section 4.2.3 and is especially detailed in Table 4.2-4.

3.7.3 Solar Radiation

Monthly-annual averages of total incoming solar radiation for the various evaporative demand zones in California (equivalent in inches of evaporation of water) are presented in Table 3.7-5. The Susanville District includes areas in the Northeast Mountain Valleys and Sierra regions; however, data is not available for the Sierra regions. The table does indicate that the Susanville District, on an annual basis, receives an abundant amount of sunshine, over 87 percent of which is received during the period March through October.

Table 3.7-6 details the monthly averages of daily solar radiation in langleys at Alturas and Reno. Alturas in the Interior Mountains CZ receives 470 langleys as compared to almost 420 langleys at Reno in the Northeast Mountains CZ.

Extreme variations can be seen at these stations on a seasonal basis. Alturas receives over 700 langleys during May through September; however, radiation totals drop as low as 155 langleys during December. Reno also shows extreme variations with totals as high as 630 langleys in July and as low as 170 langleys during December.

Table 3.7-5
 Monthly Solar Radiation Summary for the
 Susanville District
 (In Equivalent Inches of Evaporation (1))

Evaporation Region	JAN	FEB	MAR	APR	MAY	JUN	JUL	AUG	SEP	OCT	NOV	DEC	March through October	Annual Total
Northeastern Mountain Valleys (3)	3.3	5.5	7.8	9.5	12.4	13.3	15.0	12.5	9.6	6.5	3.2	2.7	88.6	100.8

(1) Solar Radiation expressed as equivalent inches of evaporation (1486 Langley's = 1 inch Ep)
 Source: State of California, "Vegetative Water Use in California, 1974".

Table 3.7-6
 Monthly Averages of Daily Solar Radiation
 For the Susanville District
 (Langley's)

Station Name	Climate Zone	JAN	FEB	MAR	APR	MAY	JUN	JUL	AUG	SEP	OCT	NOV	DEC	Annual	Period of Record
Alturas	Interior Mts.	185	259	440	593	709	723	783	709	519	365	230	155	470	1958-1970
Reno	Northeast Mts.	202	287	400	529	606	609	632	562	474	344	214	173	419	1965-1975

1 Langley = 6.45 cal/in²

Source: State of California, "California Sunshine-Solar Radiation Data", 1978

3.8 OTHER CLIMATIC PARAMETERS

This section presents analyses of various secondary climatic parameters. These parameters have considerable potential for short-term influence on BLM land use alternatives, but when considered on a long-term climatological basis, they are less significant in characterizing the climate than the parameters previously discussed. The particular climatic parameters reviewed in this section include:

- o Dew Point and Relative Humidity
- o Severe Weather
- o Barometric Pressure
- o Fog and Visibility
- o Ocean Surface Temperatures

Variations of these particular climatic parameters are briefly discussed and variations within specific climatic zones of the Susanville District are presented in the form of figures and tables. A complete bibliography is provided in the back as for previous sections.

3.8.1 Relative Humidity and Dew Point

Relative humidity and dew point temperature are discussed together in this section as they both represent measures of the available moisture in the atmosphere as a function of ambient air temperatures. Relative humidity describes the saturation moisture percentage of the atmosphere. More accurately, this parameter is defined by the ratio of the actual vapor pressure of air to the saturation vapor pressure of ambient air parcels. Dew point temperature represents the temperature to which a given parcel of air must be cooled, at constant pressure and water vapor content, in order for saturation to occur. For example, the dew point temperature is the temperature at which moisture condenses on grass and other exposed surfaces during the cool early morning hours. When this temperature is below freezing, it becomes the frost point temperature, i.e., the point at which frost will develop on exposed surfaces.

Dew point and relative humidity both provide a measure of the amount of moisture available in the atmosphere for condensation. However, care must be used in interpreting these parameters. For example, the higher the relative humidity, the higher the amount of moisture available for condensation. However, a low dew point does not necessarily mean low availability of moisture. The key criterion in interpreting dew point data is the difference between the dew point temperature and the ambient air temperature which is commonly known as the dew point depression. When this temperature difference is small, the amount of available moisture is high. When there is no difference, the atmosphere is saturated. Finally, when the dew point depression is large, the amount of available moisture in the atmosphere is quite small. In a great majority of normal atmospheric condi-

tions, supersaturation does not occur; therefore, the dew point temperature should never be higher than the ambient air temperature.

Atmospheric moisture content also plays an important role in air quality. High moisture levels not only reduce visibility but can also enhance the formation of secondary air pollutants such as sulfates and nitrates, which can further reduce visibility.

Summary tables and figures have been provided for the Susanville District which present relative humidity and dew point temperature data on a diurnal, monthly, seasonal and annual basis. Relative humidity and dew point temperature data are generally available only for major first order stations; however, the data base for the Susanville District is sufficient to provide regional long-term averages.

Figure 3.8-1 summarizes seasonal mean dew point temperature and relative humidity for the state of California. The data indicate that atmospheric moisture content is highest along the coastline, particularly in the extreme northwestern portion of the state. There is a tendency for moisture to flow in through the Bay Area and during the late fall, winter and early spring seasons, this moisture reaches the Central Valley. During other seasons of the year, most of the valley is significantly dryer than coastal locations as indicated by the figure. The southeast desert is the driest portion of the state during all seasons.

In the Susanville District, relative humidities tend to be highest in winter and lowest in summer. Detailed information on relative humidity is presented in Figure 3.8-2. Figure 3.8-3 provides a review of average dew point temperature on a monthly basis at a few key stations. Finally, diurnal distributions of relative humidity and dew point at key stations are provided in Tables 3.8-1 and 3.8-2.

To summarize the data in the tables and figures, relative humidities are highest during the winter and drop significantly to reach a minimum during the summer months. Values are highest in areas of elevated terrain and lowest at low lying stations. The amount of moisture available in the atmosphere decreases markedly with eastward progression through the Susanville District and is quite low in low lying portions of the District near the California-Nevada border and in low lying areas in Nevada. The dew point, however, displays an opposite trend with maxima during the summer and minima in the winter.

3.8.2 Severe Weather

This section presents a basic summary of severe weather in the Susanville District. The regional formation and statistical incidence of thunderstorms, tornadoes, hail and ice are

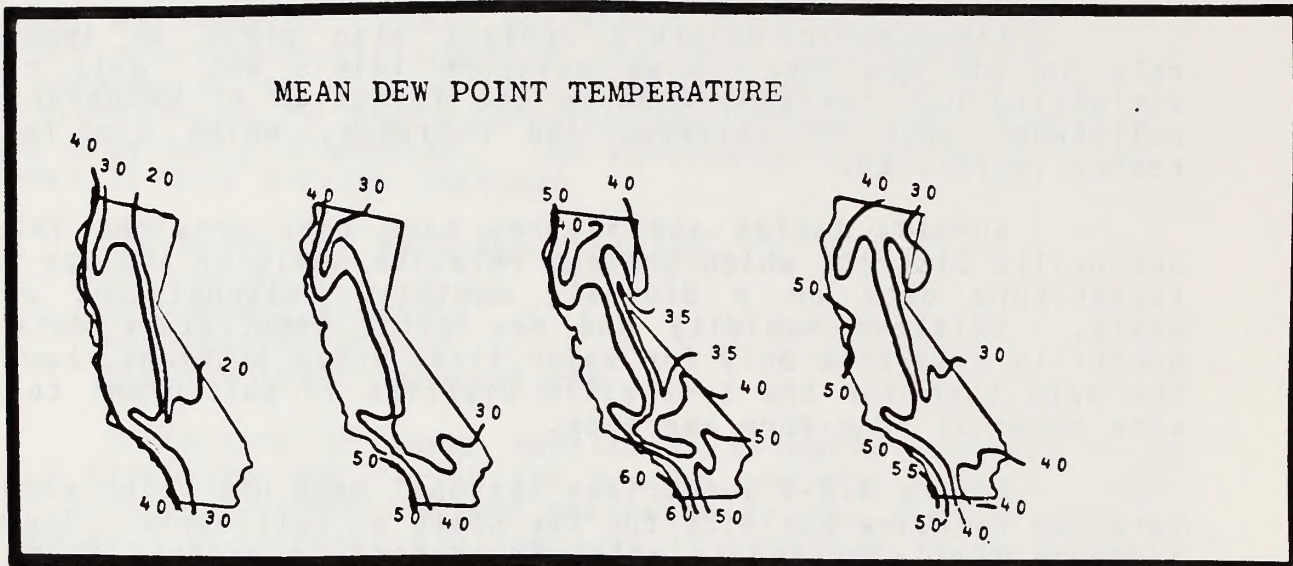

Winter

Spring

Summer

Fall

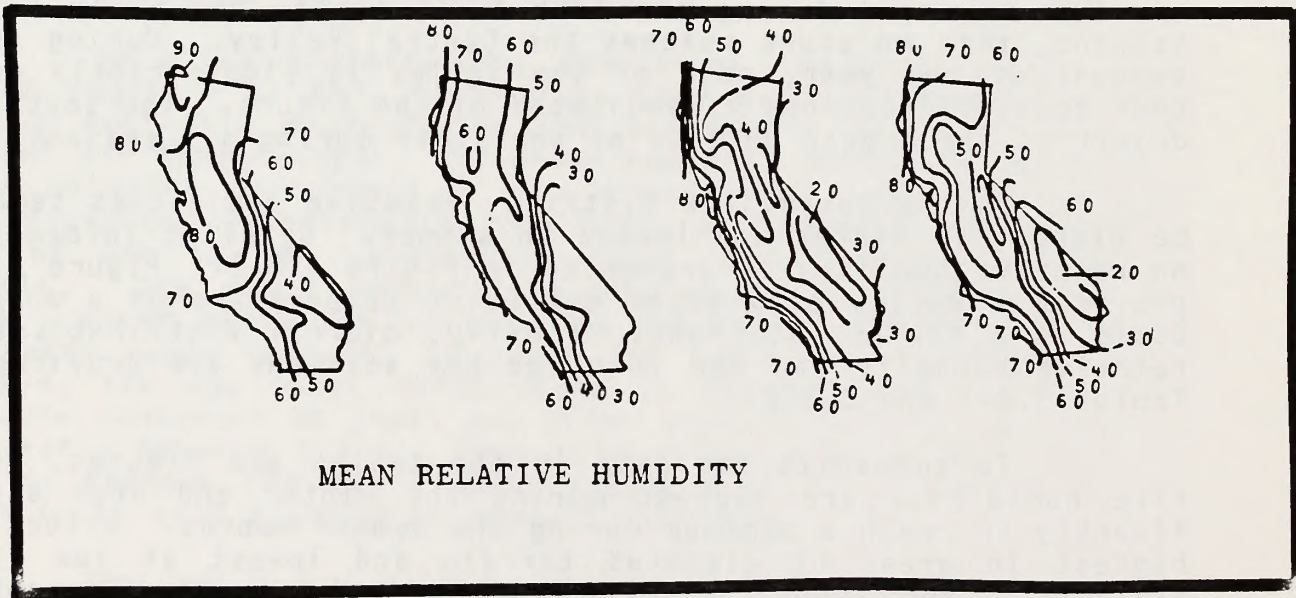

MEAN RELATIVE HUMIDITY

Figure 3.8-1
 Mean Seasonal Dew Point ($^{\circ}$ F)
 and Relative Humidity (%) in California

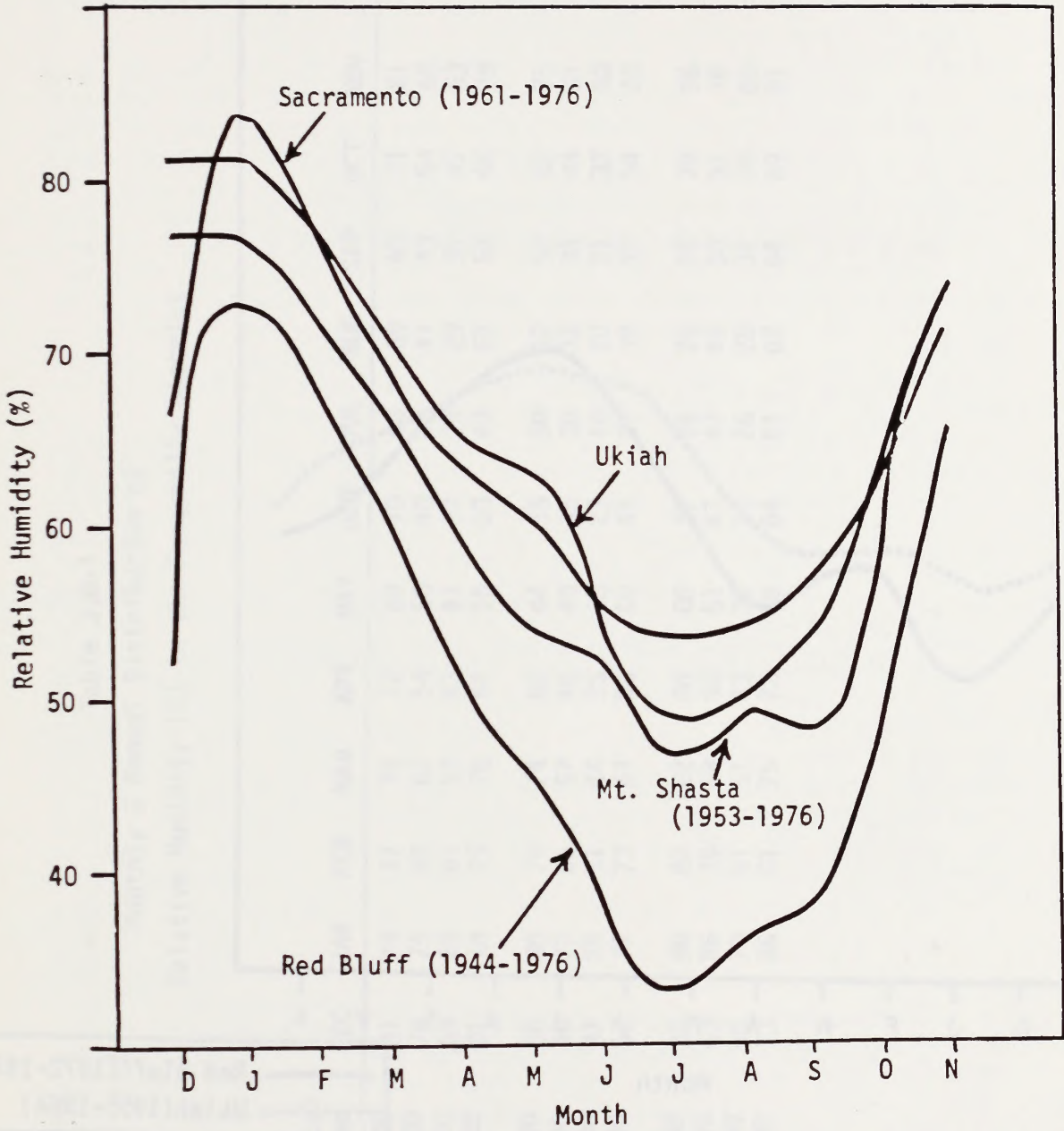

Figure 3.8-2
 Monthly-Annual Humidity Distribution
 in the Susanville District

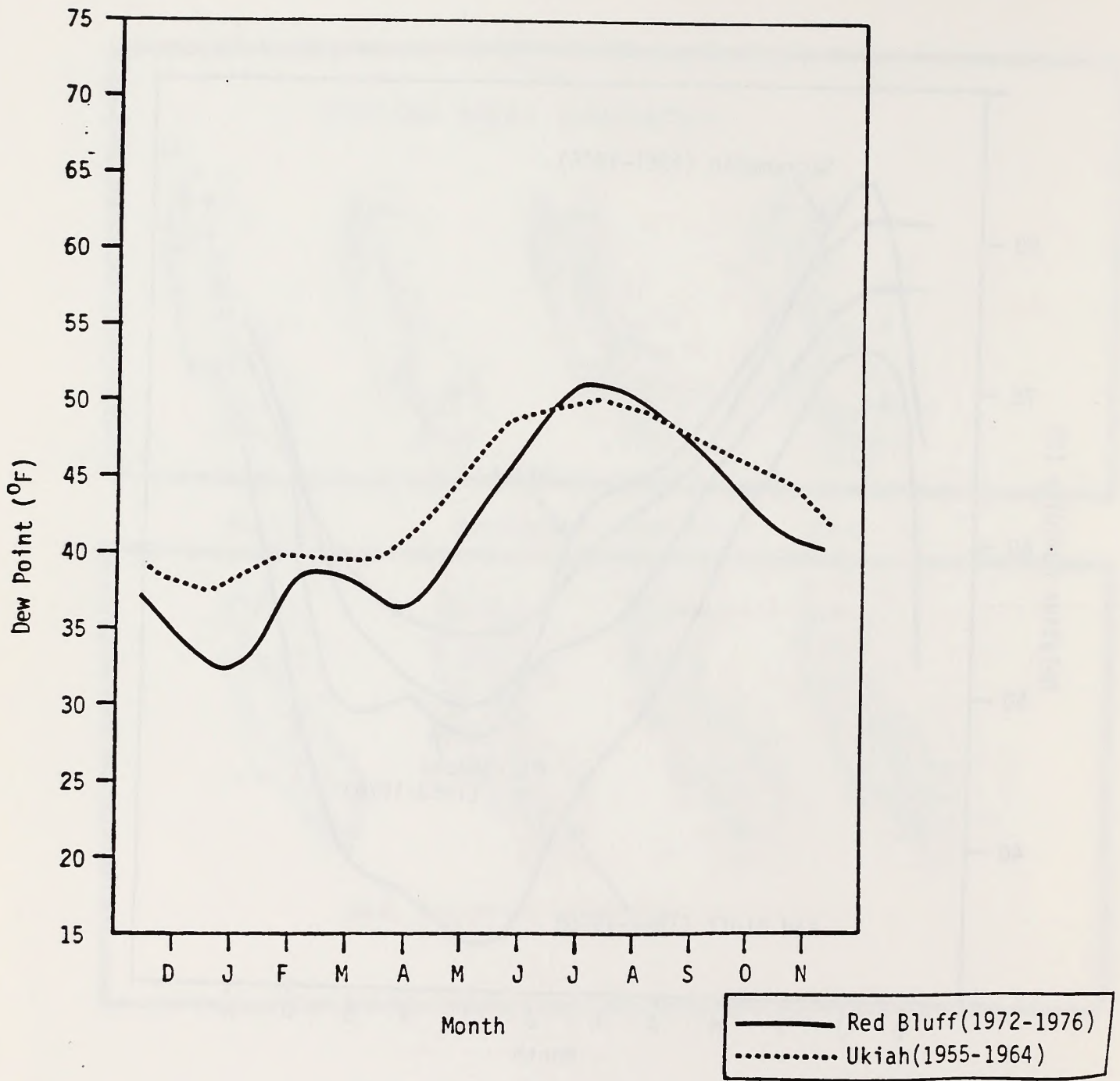

Figure 3.8-3
 Susanville District
 Monthly-Annual Dew Point Temperature

Table 3.8-1
 Monthly & Annual Distribution of
 Relative Humidity (%) in the Susanville District

	Local Time	DEC	JAN	FEB	MAR	APR	MAY	JUN	JUL	AUG	SEP	OCT	NOV	Annual
Mt. Shasta 1953-1976	0400	81	79	77	76	72	69	70	68	69	63	71	81	73
	1000	74	75	69	62	54	50	48	40	41	43	54	69	57
	1600	69	69	61	52	43	41	37	29	29	32	47	63	48
	2200	81	78	75	70	64	55	53	49	52	52	66	79	64
Red Bluff 1944-1976	0400	66	80	79	74	68	64	55	50	52	52	62	75	66
	1000	49	72	66	57	46	40	35	30	32	34	44	61	49
	1600	37	59	51	44	35	28	23	18	20	21	32	50	37
	2200	57	77	73	67	58	50	41	37	39	42	54	70	57
Sacramento 1961-1976	0400	81	90	87	82	80	80	77	76	76	76	78	86	81
	1000	63	86	79	68	58	51	47	47	49	50	57	76	63
	1600	46	70	61	51	43	36	31	28	28	31	39	60	46
	2200	73	86	81	75	72	70	64	61	62	64	69	81	73

Table 3.8-2
 Seasonal - Diurnal Distribution of Dew Point Temperature (^oF)
 in the Redding District

Hr.	Winter		Spring		Summer		Fall	
	Red Bluff	Ukiah	Red Bluff	Ukiah	Red Bluff	Ukiah	Red Bluff	Ukiah
1	34.9	39.0	39.4	42.0	49.7	48.9	44.0	44.9
2	*	38.6	*	41.7	*	49.0	*	44.6
3	*	38.2	*	41.5	*	48.9	*	44.3
4	34.3	37.8	38.7	41.1	49.3	48.8	43.4	44.0
5	*	37.5	*	40.8	*	48.6	*	43.6
6	*	37.1	*	40.5	*	48.4	*	43.3
7	33.7	36.8	39.3	40.6	50.0	49.1	43.2	43.0
8	*	36.6	*	41.6	*	50.1	*	43.5
9	*	37.0	*	42.7	*	50.9	*	44.7
10	36.1	38.3	39.7	43.4	49.6	51.6	44.6	46.0
11	*	39.9	*	43.8	*	52.0	*	46.4
12	*	40.8	*	43.9	*	51.9	*	46.4
13	36.3	41.0	38.9	43.7	47.8	51.5	44.2	46.0
14	*	40.9	*	43.2	*	50.5	*	45.2
15	*	40.8	*	43.2	*	50.2	*	44.9
16	36.1	41.0	37.9	43.0	47.0	50.0	43.8	45.0
17	*	41.3	*	42.8	*	49.5	*	45.6
18	*	41.2	*	42.8	*	49.3	*	45.8
19	36.5	41.0	39.8	42.9	48.7	49.1	45.0	45.9
20	*	40.7	*	42.7	*	49.0	*	45.8
21	*	40.5	*	42.6	*	48.8	*	45.6
22	35.7	40.2	40.0	42.6	50.8	49.0	44.7	45.5
23	*	39.7	*	42.5	*	48.9	*	45.2
24	*	39.4	*	42.3	*	48.8	*	45.0

Period of Record: Red Bluff (1972-1976)
 Ukiah (1955-1964)

*No Data

discussed in this section. The damaging effects of these abnormal weather features are also reviewed. In comparison with other areas of the country, thunderstorms, tornadoes, hail and ice occur relatively infrequently in most portions of the state.

Thunderstorms

In California, thunderstorms are rare along the coast and occur primarily during winter. On the other hand, thunderstorms developing over the interior mountains and desert are severe on occasion and occur primarily during summer. Most of the thunderstorms that occur in the Susanville District cause little, if any, damage. The storms usually are accompanied by brief gusts of wind, heavy rain and lightning as well as some small hail. Large hail, strong winds and a funnel cloud or tornado are quite rare. Flash flooding comprises the primary source of damage associated with summer thunderstorms and can be a severe problem in localized areas such as the Palm Springs storms of the summer of 1979.

Winter thunderstorms generally occur in conjunction with rapidly moving cold fronts that pass over the district. Advancing frontal systems can promote considerable instability aloft which contributes to thunderstorm development. Summer thunderstorms develop over mountainous and desert areas as strong surface heating effects couple with moist maritime air and, in the mountains, forced orographic lifting.

Isolines of the annual mean number of thunderstorm days are depicted on a national scale in Figure 3.8-4. Generally, the Susanville District experiences 10-20 thunderstorm days per year. Considerable data resolution is lacking on Figure 3.8-4 and the distribution does not reflect the higher incidence of thunderstorm days that can be experienced in the mountainous and desert areas. Isolated thunderstorm activity, as observed on radar over mountain areas, averages as high as 50 to 60 days per year at some locations. Lightning strikes resulting from these thunderstorms can cause dry brush to ignite and promote forest fires.

Tornadoes

Tornadoes and funnel clouds are associated with severe thunderstorms. They develop when just the right conditions of moisture, atmospheric stability, and winds are present. Tornadoes frequently form within thunderstorms that have organized into lines. Frequently, but not always, these "squall lines" are associated with vigorous and rapidly advancing cold fronts that promote rapid lifting of ambient air to heights in excess of 60,000 feet.

The environmental setting in California limits the potential for the development of tornadic conditions. The near proximity of the cool waters of the Pacific Ocean and the Eastern Pacific semi-permanent high pressure center tends to inhibit the

THUNDERSTORMS ANNUAL

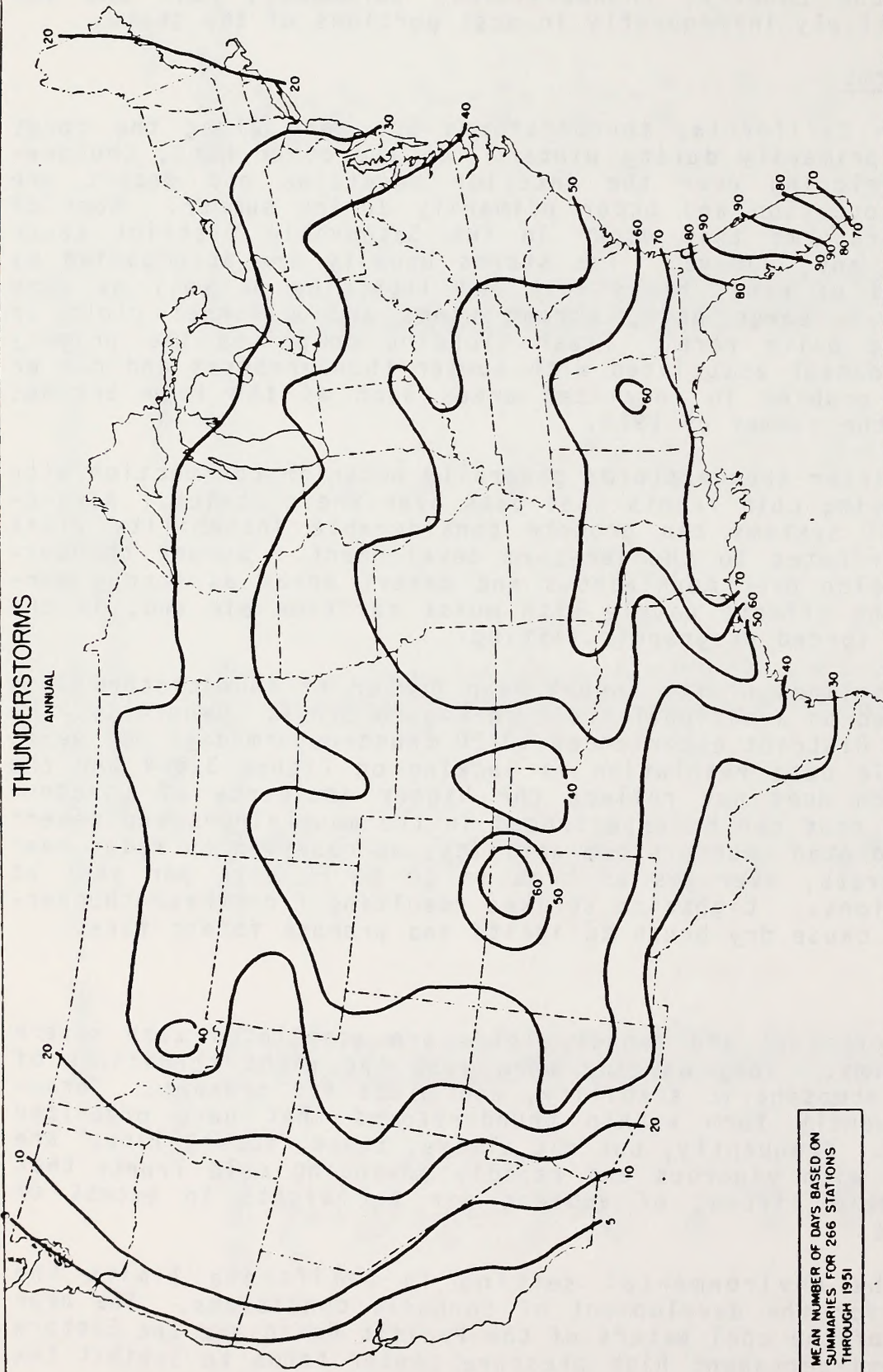

Figure 3.8-4
Mean Number of Thunderstorm Days in the United States

necessary rapid lifting of surface air. The downward air motion associated with this high pressure area tends to warm and stabilize the atmosphere, thus creating conditions adverse to tornado or severe thunderstorm activity. On rare occasions, surges of cold air at upper levels move into California and can combine with warm moist onshore surface winds to produce the unstable atmospheric conditions necessary for tornado formation.

Tornadoes have been reported in California, but with an average frequency of only 1 or 2 per year. They are generally not severe, in many cases causing little more than damage to trees or light buildings. Pilots occasionally report sightings of funnel clouds aloft, particularly off the southern California coast. The map on Figure 3.8-4 depicts areas of tornado activity in California for the period from 1930-1974. Table 3.8-3 provides a complete listing of historical tornado and funnel cloud observations for the Susanville District and nearby regions.

Fujita has presented a classification scheme for tornadoes, presented in Table 3.8-4, which has been used to categorize California tornadoes as shown in Table 3.8-5. A scale is presented below as devised by Fujita and as outlined in a report submitted to the University of California by Meteorology Research, Inc (MRI). Specifications of damage are presented as visual guidelines, and not as absolute criteria.

Photographs and eyewitness accounts of the larger tornadoes have been used to compile the various classifications. Table 3.8-5 presents a summary of the historical intensities of California tornadoes.

Hail

Hail results from the formation of spheres of irregular chips of ice which are produced by convective activity in storm clouds, such as in cumulonimbus types. Thunderstorms which are characterized by strong updrafts, high water content, large cloud drop sizes, and great vertical height extent offer great potential for hail and ice formation. Hail sizes can range from that of a few millimeters in diameter to sizes on the order of several centimeters. Table 3.8-6 presents the incidence of hail and sleet seasonally and annually at several selected stations in and near the Susanville District.

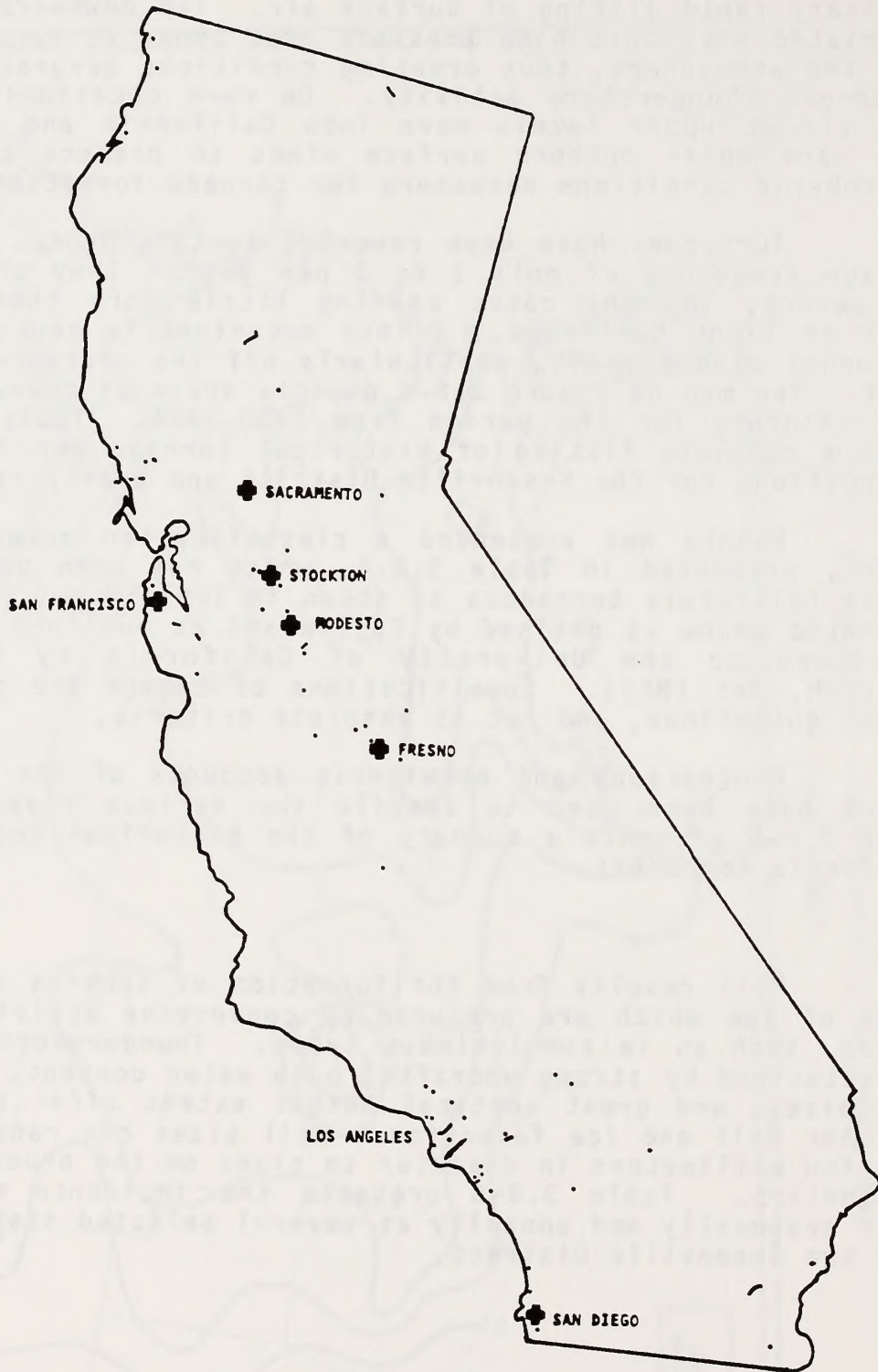

Figure 3.8-5
Tornado Activity in California
During the Period 1930-1974

Table 3.8-3
Review of Tornado Sightings
In Northern California

Date	Time	Location	Type	Remarks
March 11, 1967	1515	Sacramento	FC	
April 19, 1967	1108	Fairfield	FC*	
April 27, 1970	1720	Williams, Colusa, Arbuckle	FC	Verified by Sacramento radar
November 6, 1970	1610	Sacramento	FC	Reached to 500 ft. of ground, Observed for 16 minutes
January 12, 1971		Santa Rosa	FC	
April 18, 1972	1515	Chico	DD**	Property damage reported
October 3, 1972		Sacramento	T+	Building damage
October 15, 1972	1326	Sacramento	T	11 mi NE
October 15, 1972	1327	Sacramento	FC	2 mi SSE
August 25, 1973	1655	Pt. Arena	FC	
November 13, 1973	1548	Crescent City	WS++	6 mi N
March 30, 1974	1716	Sacramento	FC	

*Funnel Cloud
**Dust Devil
+Tornado
++Water Spout

Table 3.8-4

Fujita Tornado Classification Scheme

- (F0) GALE TORNADO, Light Damage
40-72 mph
Some damage to chimneys and TV antennae; breaks twigs off trees; pushes trees over.
- (F1) WEAK TORNADO, Moderate Damage
73-112 mph
Peels surface off roofs; windows broken; light trailer houses overturned; some trees uprooted or snapped; automobiles pushed off the road.
- (F2) STRONG TORNADO, Considerable Damage
113-157 mph
Roofs torn off frame houses leaving only strong walls upright; trailer houses destroyed; large trees snapped or uprooted; railroad box cars derailed; light object missiles generated; cars blown off highway.
- (F3) SEVERE TORNADO, Severe Damage
158-206 mph
Roofs and some walls torn off frame houses; trains derailed or overturned; steel framed hangar-warehouse type structures torn; cars lifted off the ground.
- (F4) DEVASTATING TORNADO, Devastating Damage
207-260 mph
Whole frame houses leveled, leaving piles of debris; steel structures badly damaged; small flying objects debark trees; cars and trains thrown or rolled considerable distances, large missiles generated.
- (F5) INCREDIBLE TORNADO, Incredible Damage
261-318 mph
whole frame houses tossed off foundations; automobile-sized missiles generated; incredible phenomena can occur.
- (F6) 319-379 mph
- (F7) 380-445 mph
- (F8) 446-513 mph
- (F9) 514-585 mph
- (F10) 586-659 mph

(F11) 660-737 mph

(F12) 738-818 mph

Table 3.8-5

Historical Intensity Of California Tornadoes
Based Upon the Fujita Classification Scheme

No. of Class	Percentage (%)	Storms	of Observations
F0		8	16.7
F1		32	66.7
F2		8	16.7
F3 or worse		0	0.0

Table 3.8-6

Mean Number of Days with Hail/Sleet or Ice

<u>Station</u>	<u>Winter</u>	<u>Spring</u>	<u>Summer</u>	<u>Fall</u>	<u>Annual</u>
Red Bluff	0.0	0.0	0.0	1.0	1.0
Sacramento	0.0	0.0	0.0	0.0	0.0
Ukiah	1.0	0.0	0.0	0.0	1.0

Table 3.8-7

Pressure Conversion Factors

UNITS (A)	UNITS (B)						
	POUNDS/IN ²	DYNES/CM ²	MILLIBARS	ATMOSPHERES	INCHES OF MERCURY	MILLIMETERS OF MERCURY	
POUNDS/IN ²	1.000	6.902×10^4	6.902×10^1	6.812×10^2	2.038	5.177×10^1	
DYNES/CM ²	1.449×10^{-5}	1.000	1.000×10^{-3}	9.870×10^{-7}	2.953×10^{-5}	7.501×10^{-4}	
MILLIBARS	1.449×10^{-2}	1.000×10^3	1.000	9.870×10^{-4}	2.953×10^{-2}	7.501×10^{-4}	
ATMOSPHERES	1.468×10^1	1.013×10^6	1.013×10^3	1.000	2.992×10^1	7.600×10^2	
INCHES OF MERCURY	4.906×10^{-1}	3.386×10^4	3.386×10^1	3.342×10^{-2}	1.000	2.540×10^1	
MILLIMETERS OF MERCURY	1.932×10^{-2}	1.333×10^3	1.333	1.316×10^{-3}	3.937×10^{-2}	1.000	

* Multiply pressure in (A) units by appropriate factor to transform into (B) units (i.e. $14.68 \text{ LBS/IN}^2 \times 6.902 \times 10 = 1013.2 \text{ mb}$).

Figures 3.8-6 through 3.8-9 provide a representative cross-section of the mean seasonal pressure contours on a national scale. General atmospheric flow can be estimated by assuming that winds move nearly parallel to isobars (lines of equal pressure values). In the northern hemisphere, winds blow clockwise (anticyclonic) around the high pressure centers and counterclockwise (cyclonic) about low pressure centers.

During the winter months, a high pressure center is generally situated to the northeast of California and the semi-permanent Eastern Pacific high pressure system is depressed well to the south. This permits moist air to be channeled into the state from the northwest, west and southwest. The strong potential for moisture advection during the winter months in California promotes the "rainy" season. Air quality also tends to be better during this season.

In the hot summer months, a low pressure center dominates the southwestern portion of the nation. Winds generally flow inland as the sea breeze regime becomes established. The Eastern Pacific High Pressure area becomes well entrenched over California and inhibits the flow of moist, maritime air into the area, thus permitting the development of high pollutant levels.

Definite pressure cycles occur on numerous time scales. Mean pressure values experienced in particular regions vary seasonally and diurnally. Latitude, elevation, topography and surface albedo collectively influence the mean pressure tendencies registered at a particular location. Variations in atmospheric pressure, at selected key stations in and near the Susanville District, are depicted on a monthly-annual basis in Figure 3.8-10 and on a diurnal-seasonal basis in Figure 3.8-11.

3.8.4 Visibility and Fog

Visibility provides an indication of atmospheric clarity. Visibility measurements or estimates are generally expressed in miles or kilometers denoting the maximum distance at which one can distinguish objects such as buildings, mountains and other large landmarks. Visibility reduction is the result of numerous physical factors that include both general air quality as well as thermodynamic and optical properties. Some of the more common factors that play an important role in atmospheric visibility and contrast reduction are air moisture content, relative humidity, falling rain, snow, hail, blowing dust, sea spray, high concentrations of suspended particulate matter, sulfates, oxides of nitrogen, and smoke.

Tables 3.8-8 and 3.8-9 present monthly and seasonal percentage frequency distributions of visibility for nearby Red Bluff and Ukiah. The data represent observations of visual range by trained NWS observers at major airport locations. The data indicate that visibility is generally between 10 to 25 miles at

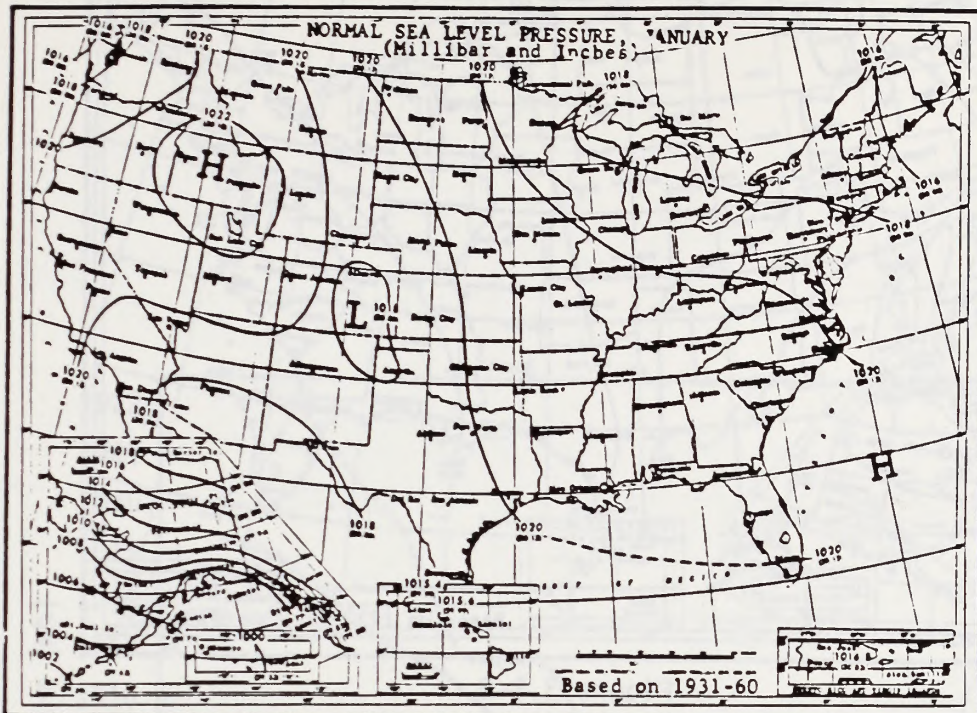

Figure 3.8-6
Mean Winter (January) Pressure Distribution
in the United States

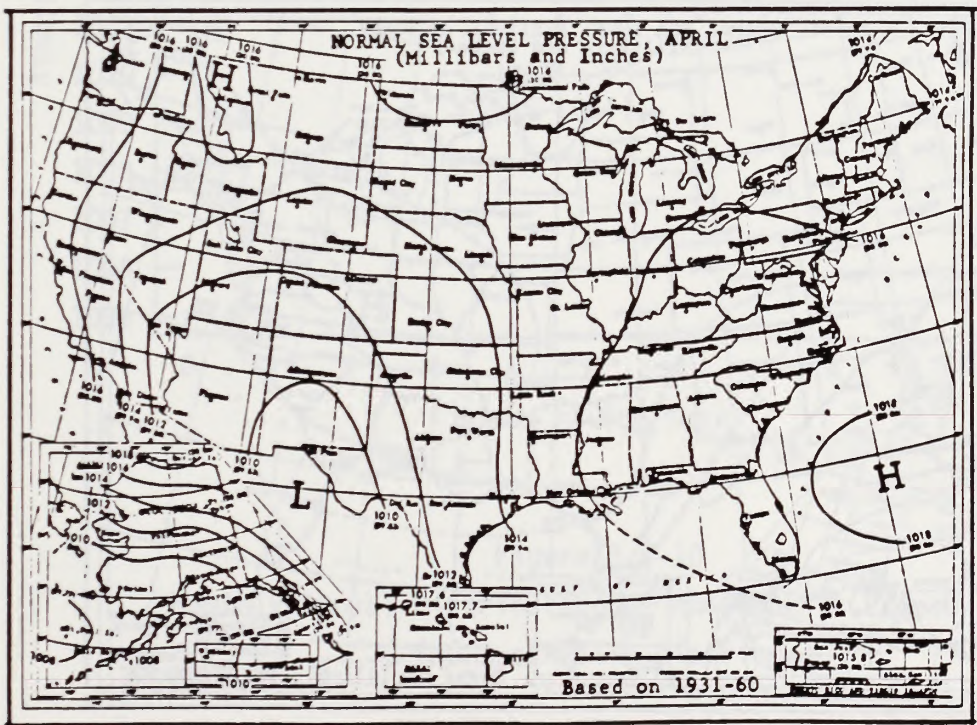

Figure 3.8-7
Mean Spring (April) Pressure Distribution
in the United States

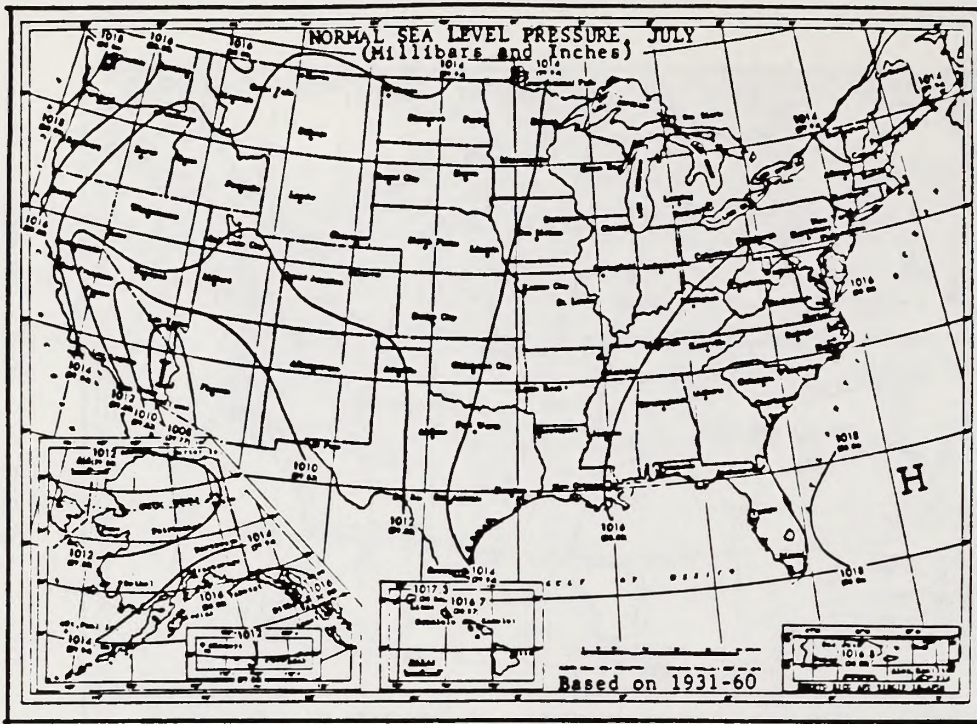

Figure 3.8-8

Mean Summer (July) Pressure Distribution
in the United States

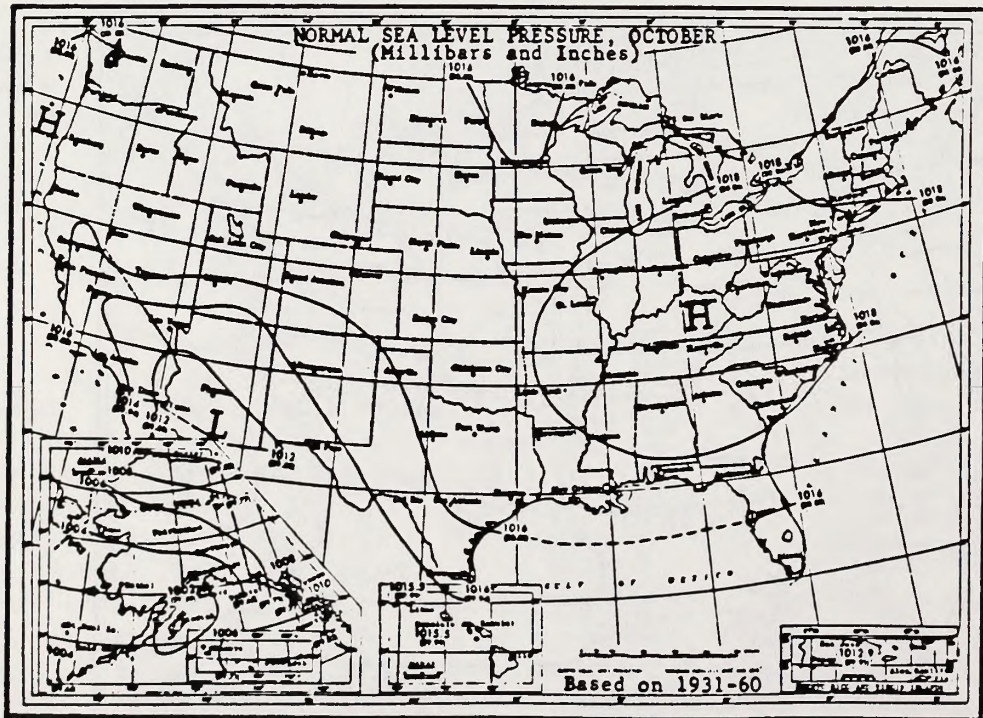

Figure 3.8-9

Mean Fall (October) Pressure Distribution
in the United States

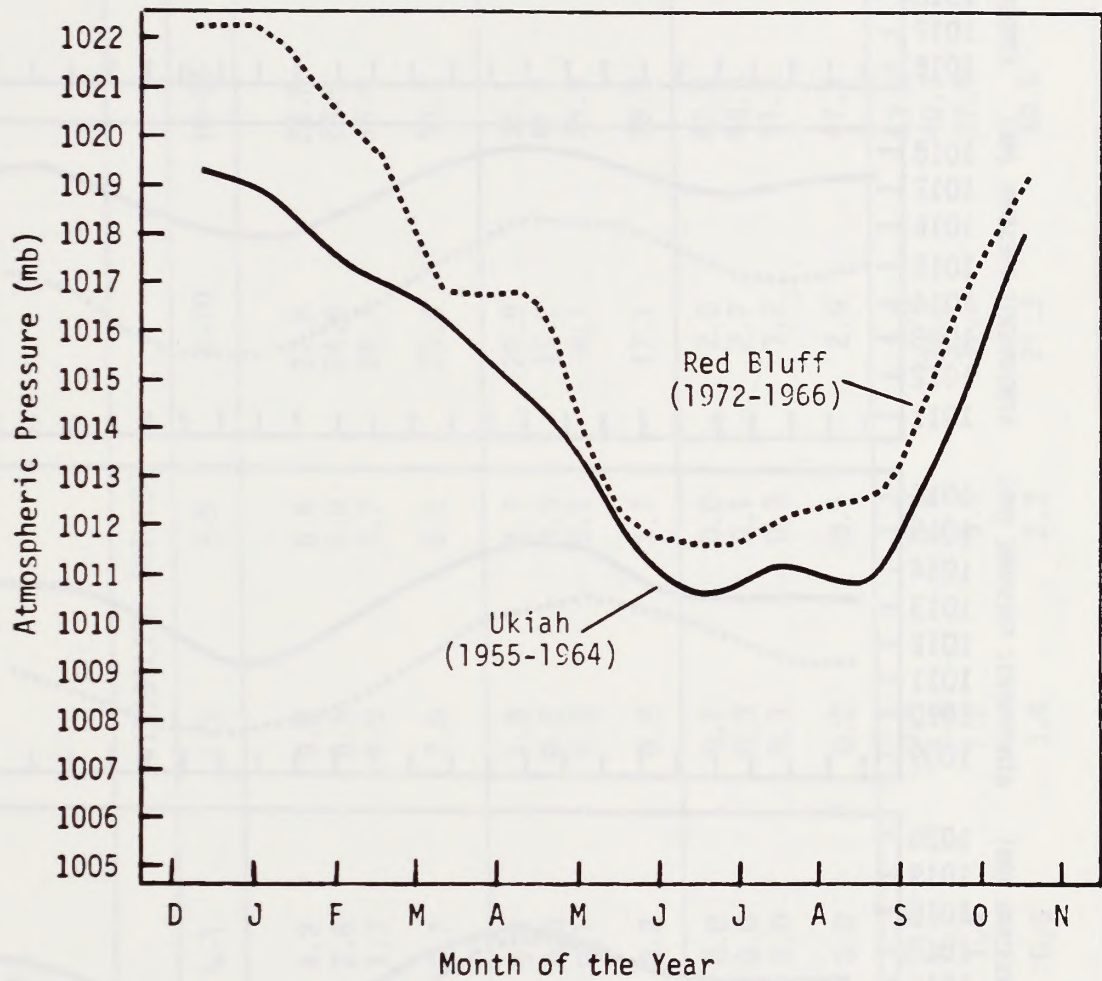

Figure 3.8-10
 Monthly-Annual Distribution of Atmospheric Pressure in
 the Susanville District

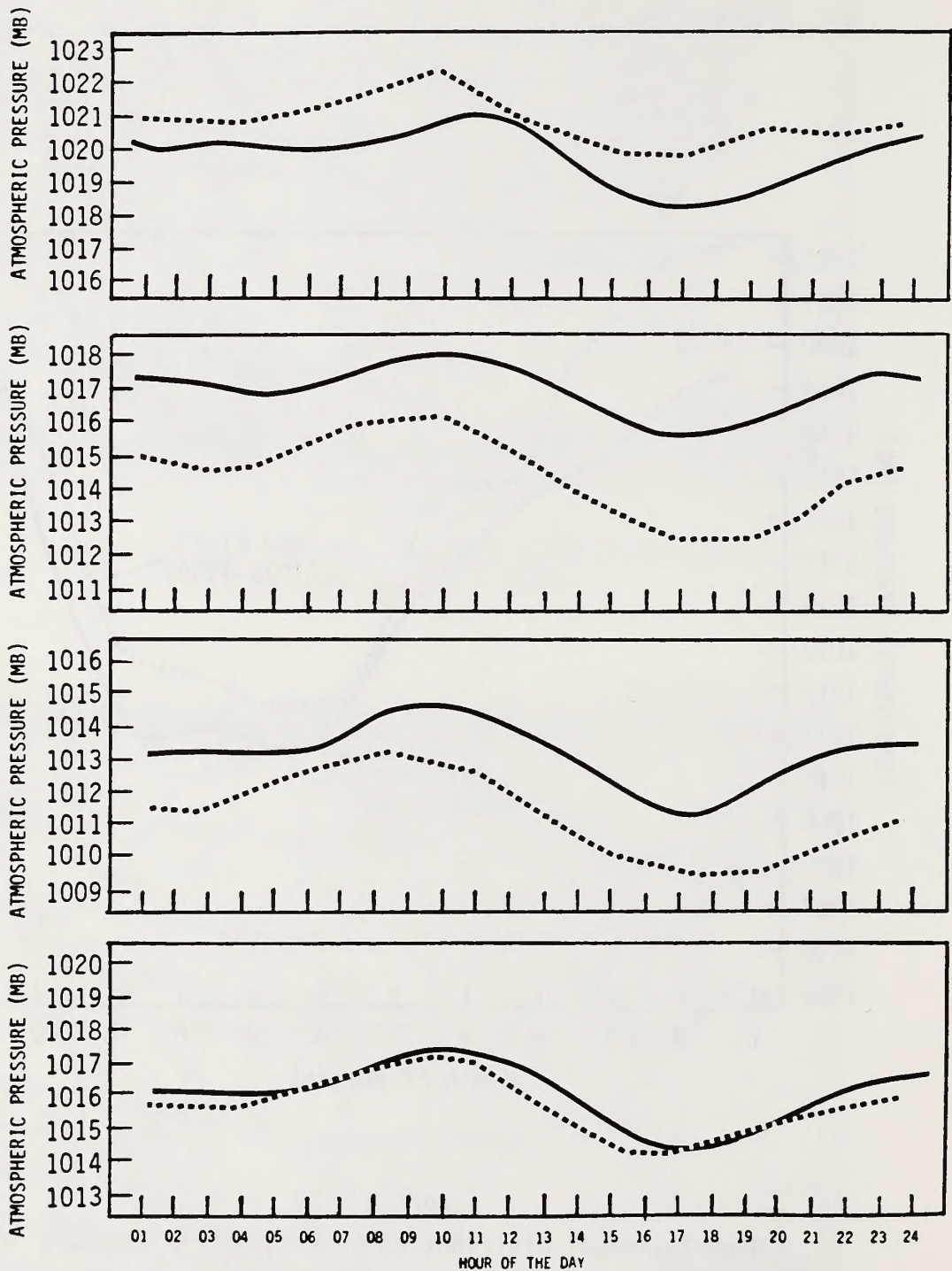

Figure 3.8-11

Diurnal-Seasonal Pressure Variations in the Susanville District

Analyses based on 8 obs/day

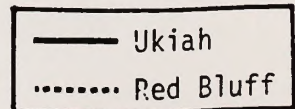

Table 3.8-8

Frequency (%) of Selected Visibility Categories at Red Bluff, California
for the Period of 1972 - 1976

PERIOD	VISIBILITY (MILES)						
	< ¼	¼-1	1-3	3-5	5-10	10-25	> 25
DEC	8.2	4.2	9.8	6.8	22.8	26.8	21.4
JAN	6.8	2.6	8.5	5.0	24.9	28.5	23.8
FEB	1.0	1.3	4.0	3.7	28.7	35.9	25.4
WINTER	5.5	2.7	7.6	5.2	25.4	30.2	23.5
MAR	0.4	0.4	1.9	2.7	29.9	35.1	29.6
APR	0.0	0.0	0.2	0.5	15.2	41.4	42.8
MAY	0.0	0.1	0.2	0.1	6.1	39.8	53.6
SPRING	0.1	0.2	0.8	1.1	17.1	38.8	42.0
JUN	0.0	0.0	0.1	0.0	2.6	43.2	54.2
JUL	0.0	0.0	0.3	0.1	2.7	48.3	48.5
AUG	0.0	0.0	0.1	0.3	3.2	51.5	44.8
SUMMER	0.0	0.0	0.2	0.1	2.9	47.7	49.1
SEP	0.0	0.2	0.4	0.0	7.8	53.6	38.1
OCT	0.1	0.2	2.6	1.9	24.7	40.7	29.8
NOV	4.3	1.4	7.2	5.0	31.3	27.6	23.3
FALL	1.4	0.6	3.4	2.3	21.3	40.6	30.4

Table 3.8-9
 Frequency (%) of Selected Visibility Categories at Ukiah, California
 for the Period 1955-1964

PERIOD	VISIBILITY (MILES)						
	<1/4	1/4-1	1-3	3-5	5-10	10-25	>25
DEC	10.1	4.2	11.2	8.8	30.9	30.6	4.2
JAN	8.6	3.8	8.7	7.1	34.2	32.2	5.4
FEB	2.3	1.4	5.0	5.9	31.5	45.0	8.9
WINTER	7.2	3.2	8.4	7.3	32.2	35.6	6.1
MAR	0.8	0.6	2.7	4.6	22.3	56.1	12.9
APR	0.3	0.2	1.3	1.9	13.8	64.4	18.1
MAY	0.3	0.2	0.9	1.6	12.2	63.6	21.2
SPRING	0.5	0.4	1.6	2.7	16.1	61.3	17.4
JUN	0.1	0.1	0.3	0.8	8.8	64.2	25.8
JUL	0.1	0.0	0.2	0.7	7.4	68.9	22.7
AUG	0.0	0.1	0.3	1.7	9.3	71.2	17.4
SUMMER	0.0	0.1	0.3	1.1	8.5	68.2	21.9
SEP	0.1	0.1	1.0	2.1	15.2	68.6	13.0
OCT	1.1	1.2	3.4	4.0	22.8	58.6	8.8
NOV	5.2	2.3	7.1	8.0	33.9	37.1	6.4
FALL	2.1	1.2	3.9	4.7	24.0	54.7	9.4

Red Bluff and Ukiah. Poorest visibility occurs during winter when fogs occur most frequently.

In the mountains, visibility is extremely variable. Data is very scarce and the BLM is participating in programs geared to determine visibility on federally-administered lands. The data presented in Tables 3.8-8 and 3.8-9 is not felt to be indicative of conditions in rural, mountainous locations.

Air quality can be determined from visibility observations at particular locations within the district. By eliminating moisture influences on atmospheric clarity, the remaining reduction in visibility is largely due to suspended air contaminants. Table 3.8-10 presents the number of hours that substantial visibility reduction occurred due to non-moisture effects. The criteria denoting a visibility violation in California was used to develop this table. A violation occurs when visibility is less than 10 miles and the relative humidity is less than 70 percent. Once again, data are not available for stations within the Susanville District. However, data also available for nearby Red Bluff and Ukiah. Table 3.8-10 indicates that violations of the California visibility standard occur primarily during the fall and winter months, when stagnation episodes occur.

Fog

Considerable visibility reduction is directly related to ambient moisture levels. Table 3.8-11 presents the mean number of days that visibility is less than one-quarter mile due to the presence of heavy fog.

Available data indicate that visibility is reduced to less than one-quarter mile due to heavy fog during 10 days in January at both Red Bluff and Sacramento. Available data from Ukiah also shows the same tendency. The frequency of heavy fog is much reduced at Mt. Shasta with a maximum occurrence of visibility reduction (less than one-quarter mile) occurring during December and January with an average annual frequency of two days. This reflects a trend that will be noted throughout the District. Heavy fog is most frequent in nearby Sacramento and the Sacramento Valley, particularly during the winter months in a condition known locally as Tule Fog. In the mountainous portions of the District, heavy fog will be limited to restricted valley locations and the frequency of heavy fog will be quite low over most of the well exposed higher terrain of the District.

Fog, is associated with moist, cool, surface air masses at the point of saturation. Fog can be classified into numerous types according to the physical processes responsible for its development. Fog types that are common in the Folsom District include:

Table 3.8-10
 Total Hours Violating the California Visibility Standard
 in the Susanville District

YEAR	RED BLUFF												POS OBS				
	DEC	JAN	FEB	WINTER	MAR	APR	MAY	SPRING	JUN	JUL	AUG	SUMMER		SEP	OCT	NOV	FALL
1972	7	12	7	26	17	19	22	58	5	3	11	19	7	30	10	47	2920
1973	3	7	6	16	11	16	12	39	0	0	0	0	26	23	12	61	2920
1974	16	23	14	53	15	2	1	18	4	12	15	31	20	36	11	67	2915
1975	7	7	4	18	10	8	5	23	0	0	0	0	2	9	12	23	2901
1976	42	5	6	53	4	2	0	6	4	1	2	7	5	37	21	63	2920

YEAR	UKIAH												POS OBS				
	DEC	JAN	FEB	WINTER	MAR	APR	MAY	SPRING	JUN	JUL	AUG	SUMMER		SEP	OCT	NOV	FALL
1955	24	66	53	143	42	22	58	122	58	58	154	270	105	74	58	237	8755
1956	57	7	41	105	44	26	22	92	34	48	17	99	34	58	147	239	8750
1957	53	32	26	111	20	44	37	101	63	71	86	220	73	31	41	145	8743
1958	86	23	7	116	19	16	26	61	20	59	54	133	90	112	66	268	8753
1959	141	42	35	219	15	23	15	53	14	79	79	172	26	69	235	330	8758
1960	31	27	24	83	7	4	5	16	28	28	38	94	55	66	25	146	8759
1961	15	69	19	103	10	11	2	23	35	40	66	141	71	103	64	238	8760
1962	9	31	14	54	13	10	3	26	14	21	33	68	54	13	20	87	8755
1963	36	26	6	68	13	35	20	68	22	34	62	118	58	42	10	110	8750
1964	0	16	30	46	18	10	18	46	19	14	14	47	37	49	9	95	7707

Table 3.8-11
 Mean Number of Days with Visibility Less than ¼ Mile
 Due to Heavy Fog
 For the Susanville District

	JAN	FEB	MAR	APR	MAY	JUN	JUL	AUG	SEP	OCT	NOV	DEC	Annual	Period
Red Bluff	10	6	2	*	*	0	0	*	*	2	6	9	35	1945-1976
Mt. Shasta	2	1	*	*	0	*	0	0	*	*	1	2	7	1961-1976
Ukiah	9	2	1	*	*	*	*	0	*	1	5	10	29	1955-1964
Sacramento	10	6	2	*	*	0	0	*	*	2	6	9	35	1949-1976

- o Radiational
- o Advection
- o Frontal

A very common type of land fog often experienced in the mountain valleys known as radiational or surface inversion fog, is produced by the radiational cooling of relatively shallow layers of calm, humid air, overlying a chilled land surface. This type of fog development requires certain nighttime conditions which include:

- o Stable surface air
- o Light or calm winds
- o Clear skies

Stable surface conditions inhibit vertical diffusion of fog formed at the surface. Light winds promote radiational fog development by limiting mixing. Cloudless skies promote fog since they allow rapid heat loss from the surface thus permitting the ground to cool rapidly, even below surface air temperatures.

Radiational fog occurs in low-lying areas as cool, dense air drains into valleys and low-lying regions. Often, hilly areas will remain clear while adjacent lowlands are foggy. Radiational or ground fog deepens from the ground upward at night and is dissipated during the day by the warming sunlight from the top downward.

Advection fog, unlike radiational fog, requires considerable air movement to promote formation. It simply requires that warm moist air masses be moved over cold surfaces and this most commonly occurs over ocean and coastal locations during summer. During this period, pressure gradients between oceanic and inland air masses are at a maximum, thus promoting inland movement (sea breeze). At coastal locations, warm moist air is channelled over and mixed with cold, moist, surface maritime air. Condensation of water vapor in the ambient air is promoted, thus forming fog. This type of coastal sea fog is most commonly observed during the summer months.

3.9 URBAN EFFECT UPON METEOROLOGICAL PARAMETERS

There is hardly a meteorologic element that can be named that is not influenced to some extent by cities. It is, however, difficult to separate urban effects from microclimatologic effects since very few measurements have been made with the specific aim of comparing urban and non-urban measurements. There are several causes for the differences between urban and open country climates. One of these is the alteration of the surface, e.g., the change from meadow, forest or swamp to buildings and streets of concrete, brick, steel, and asphalt. Not only does this cause changes in reception and reflection of solar radiation and evaporation, but also in the roughness of the surface over which the wind moves. Another change involves the production of a sizable quantity of heat due to combustion processes carried out in the city and the addition of material to the atmosphere in the form of dusts, gases, and vapors which change the atmosphere's composition in the vicinity of cities.

Temperature

The comparison of temperatures within cities with those outside reveal that city temperatures, especially at time of minimum, are higher (Mitchell, 1961). Also during the period right after sunset, the city temperature does not cool as rapidly as does the country air due to heat content of buildings and radiation between buildings, rather than toward the sky. Between sunrise and noon, urban and non-urban temperatures are nearly the same (Landsberg, 1956). The influence of the city extends in the vertical on the order of three times the height of the buildings (Duckworth and Sandberg, 1954). The average heat island effect over New York City extends to 300 meters (~ 1000 feet) and has been observed as high as 500 meters (~ 1650 feet) (Bernstein, 1968). Also, the change of temperature with height is quite different over the city, especially at night. In the open country, radiation inversions form frequently, whereas in the city, isothermal or neutral conditions frequently exist through the night with a radiation inversion layer above the city (DeMarrais, 1961).

Since temperatures in the city are warmer than those of the surrounding countryside, the city's heating requirements are less by as much as 10%. Variations between city and country temperatures are extremely noticeable at northern latitudes when the countryside is covered with snow which has melted in the city.

Humidity

Lower relative humidities exist in cities partly due to higher temperatures, but also because of lower absolute humidity. Although little is available in the way of measurements, it is felt that lower absolute humidities are a consequence of the rapid runoff of precipitation in the cities. Also, the existence

of little vegetation in the urban environment reduces moisture received from evapotranspiration processes (Landsberg, 1956).

Precipitation

Precipitation is one of the most variable meteorological elements and, because of this, it is difficult to establish significant differences between urban and non-urban areas. However, numerous studies have been made which show either greater precipitation amounts and/or greater frequency of precipitation within cities. Schmauss in 1927 showed 11 percent increase of days with small amounts of precipitation occurring in Munich compared to stations outside the city. Bolgolepow in 1928 reported an increase in precipitation of 10 percent in Moscow compared to a country station for 17 years of record. Ashworth in 1929 noted the increase of average annual precipitation over 3 decades amounting to 13 percent. He also noted less increase for Sundays than for weekdays. Wiegel in 1938 using a 35 year record, noted a 5 percent increase in precipitation, as well as a 12 to 18 percent increase in the number of days with precipitation for the Ruhr area of Germany. These references are all reported in Landsberg (1956). Landsberg also reports a study for Tulsa where topographical effects are at a minimum and the urban area is confined to a rather definite area. In addition to a precipitation increase within the city over a 70 year period, there was an increase of 7 percent in the city compared to surroundings for a 14 year period.

Two more recent studies by Changnon (1961a, 1961b) indicate there may be some urban effect upon precipitation over Chicago and the moderate-sized communities of Champaign, and Urbana, Illinois.

The principal suspected causes of the increase of precipitation over cities is the increase of condensation nuclei over cities due to air pollutants and the increased turbulence caused by increased surface roughness. Although water vapor is added to the air from combustion sources, this is not expected to add significantly to the amount of precipitable water or to evoke a major effect.

Snow

Precipitation in the form of snow indicates to some extent the influence of temperature in the urban area. Kossner in 1917 and Maurain in 1947 indicated greater frequencies of snowfall outside as compared to within Berlin and Paris, respectively. On the other hand, Kratzer in 1937 in Munich reported occurrences of snow within the city when none occurred in the surroundings, and Keinle in Mannheim, a heavy industry location, reported that snow fell from a fog and stratus layer on two successive days in January 1949 while none fell outside the urban area. It is probable that this was due to air pollutants furnishing condensation nuclei for supercooled water vapor. These

references appear in Landsberg (1956) who also estimates a 5% average decrease in snowfall for urban areas (Landsberg, 1968).

Cloudiness

From climatological records there seems to have been a slight increase in cloudiness over the years but this has been so slight (less than 1/10 of mean sky cover) that for so subjective a measure as sky cover this may not be significant. Any increase may be primarily due to city fogs, as increases in early morning cloud cover seems to be greatest. Nearly all large cities show a decrease in the number of clear days over that observed in adjacent rural areas. The primary effects may be expected to be due to addition of condensation nuclei by air pollution and the release of additional water vapor. Kratzer in 1937 in Munich indicated an 8 percent increase in summer cloudiness compared to a 3 percent increase in winter cloudiness over the city (Landsberg, 1956). This may indicate that surface roughness and therefore, increasing turbulence, may play a part in the formation of cumulus type summer clouds.

Wind

Because of the general increase of the size of the roughness elements in the city over that in the rural areas, wind speeds are decreased within the city. Also the frequency of calms is increased on the order of 5 to 20 percent (Landsberg, 1956). Recently, Pooler (1961) has shown that under conditions of light stable flow, an inflow of air toward the center of the city of Louisville occurs (heat island effect). In addition to the decrease of wind speed in cities, there is of course channeling of the wind in the canyons formed by alternating streets and groups of buildings.

Radiation

The decrease of solar radiation within cities as compared to rural areas is on the order of 15 to 20 percent. This is due to the absorption, reflection, and scattering of particles in the atmosphere, and the absorption of gases. These particles and gases are primarily the result of air pollution. The radiation most affected is the ultraviolet with the infrared being least affected. This is important because of the bactericidal effect of ultraviolet radiation.

Recently, McCormick (1960) has begun measuring of the attenuation of the solar beam at 0.5 micron wave length in order to have an objective measure of the entire pollution layer. In terms of duration of sunshine, Landsberg (1968), shows a decrease in the range of 5-15% in urban areas. Randerson (1970) has showed an average of 23% loss in intensity of light attributed to pollution in Houston, Texas.

Visual Range

The decrease of visibility in urban areas is probably the most noticeable of meteorological differences between urban and rural areas. Comparisons between hourly observations of visibility at city locations and at rural locations (Landsberg, 1956) have shown higher frequencies of fog, smoke, and low visibilities than in neighboring rural areas.

Holzworth and Maga (1960) analyzed visibility measurements from California locations to determine if trends which might be caused by increases in air pollution were noticeable. Results indicated that several cities showed trends toward lowering visibilities. Other showed lowering visibilities until efforts at controlling certain pollutants were made, after which no trend was discernible.

3.10 GENERAL ASSISTANCE IN CLIMATIC PROBLEMS

REFERENCES

o Abstracts

Meteorological and Geostrophysical Abstracts
American Meteorological Society
45 Beacon Street
Boston, Mass.

o Periodicals

Bulletin of the American Meteorological Society
American Meteorological Society (See above)

Journal of Applied Meteorology
American Meteorological Society (See above)

Journal of the Atmospheric Sciences
(formerly Journal of Meteorology)
American Meteorological Society (See above)

Monthly Weather Review
U.S. Dept. of Commerce
Weather Bureau
Washington, D.C.

Quarterly Journal of the Royal Meteorological Society
Royal Meteorological Society
49 Cromwell Road
London, S.W. 7

Weather
Royal Meteorological Society (See above)

Weatherwise
American Meteorological Society (See above)

o Books

American Meteorological Society, On Atmospheric Pollution,
Meteorological Monographs, 1, 4, Nov. 1951.

Byers, H.R. General Meteorology,
McGraw-Hill, New York, 3rd ed. 1959.

Geiger, R. (Translated by Scripta Technica Inc.)
The Climate Near the Ground.
Rev. ed., Harvard University Press, Cambridge,
Mass. 1965.

Haltiner, G.J.; and Martin, F.L. Dynamical and Physical Meteorology.
McGraw-Hill, New York. 1957

Hess, S.L. Introduction to Theoretical Meteorology.
Henry Holt, New York, 1959.

Hewson, E.W.: and Longley, R.W. Meteorology, Theoretical and Applied
Wiley, New York. 1944.

Professional Meteorological Consultants

Professional meteorologists advertise their services in the Professional Directory section of the Bulletin of the American Meteorological Society. In the May 1979 Bulletin, 83 such firms and individuals were listed. The American Meteorological Society has in the last several years instituted a program of certifying consulting meteorologists. Of the 83 professional services listings in the Bulletin, 40 list Certified Consulting Meteorologists.

Local U.S. National Weather Service Office

A wealth of meteorological information and experience is available at the local city or airport Weather Service Office pertaining to local climatology, peculiarities in local micro-meteorological conditions including topographic effects, and exposure and operating characteristics of meteorological instruments.

Contract Work

Many universities do contract work for private organizations and for government agencies on meteorological problems.

BIBLIOGRAPHY

- Bernstein, R.D., Observations of the Urban Heat Island Effect in New York City. J. Appl. Meteor. 7, 4:575-592, Aug., 1968.
- California Energy Commission, California Solar Data Manual, Sacramento, California, 1978.
- California Snow Survey Service, Historical Data of Cooperative Snow Survey Measurements, available through the State of California Resources Building, Sacramento.
- Changnon, Stanley A. Jr., "Precipitation Contrasts Between the Chicago Urban Area and An Offshore Station in Southern Lake Michigan", Bull. of the American Meteorol. Soc., 42, 1, 1-10, Jan. 1961.
- Climatic Atlas of the United States
- Climatological Study; Southern California Operating Area, Fleet Weather Facility, San Diego, California.
- DeMarrais, Gerard A. "Vertical Temperature Difference Observed Over an Urban Area", Bull. of the Amer. Meteorol. Soc., 42, 8, 548 - 554, Aug. 1961.
- Duckworth, F.S. and Sandberg, J.S. "The Effect of Cities Upon Horizontal and Vertical Temperature Gradients", Bull. of the Amer. Meteorol. Soc., 35, 5, 198-207, May 1954.
- Elford, C. Robert, Climate of the States: Climate of California, U.S. Department of Commerce, ESSA, 1970.
- Felton, Ernest L., California's Many Climates, Pacific Books Publishers, Palo Alto, California, 1968.
- Findeison, W., Meteorol. Z. 56, 453 1937.
- Frederick, R.H. Weather Data for Air Pollution-Available, Analyzed and Inexpensive. J. of Air Pollution Control Assoc. 14:2, 60-65. 1964.
- Fujita, T.T., 1970a: Estimate of a Real Probability of Tornadoes from Inflationary Reporting of Their Frequencies. Dept. of Geophys. Sci., Univ. of Chicago, SMRP Research Paper No. 89.
- Goodridge, Dr. James, personal notes, Dept of Water Resources, State of California, Sacramento, California.
- Hoecker, W.H., 1961: Three-Dimensional Pressure Pattern of the Dallas Tornado and Some Resultant Implications. Mon. Wea. Rev., 89, 12, 533-542.

- Holzworth, G.C. and Maga, J.A., "A Method for Analyzing the Trend in Visibility", J. Air Poll. Control Assoc., 10, 6, 430-435, Dec. 1960.
- Houghton, H.G., "On the Annual Heat Balance of the Northern Hemisphere" J. Meteorol., 11, 1, 1-9. Feb. 1954.
- Landsberg, H.E. "The Climate of Towns" in Man's Role in Changing the Face of the Earth, Thomas, W.L. Jr., ed. Univ. of Chicago Press, 1956.
- Landsberg, H.E. Climate and Urban Planning Pres. WMO Symposium of Urban Climates and Building Climatology. Brussels, October 19, 1968.
- Lynn, Ronald J., Seasonal Variation of Temperature and Salinity at 10 meters in the California Current, Bureau of Commercial Fisheries, Tuna Resources Laboratory, La Jolla, California.
- McCormick, R.A. and Tabor, E.C. "U.S. Weather Bureau-Public Health Service Precipitation Chemistry and Aerometric Studies" presented at the 12th General Assembly, Int. Union of Geodesy and Geophysics, Helsinki, Finland, July 26 - Aug. 6, 1960.
- Mitchell, J. Murray, Jr. "The Temperature of Cities", Weatherwise, 14, 6, 224-229, December 1961.
- National Data Buoy Center, National Ocean Survey, National Oceanic and Atmospheric Association, Environmental Conditions within Specified Geographical Regions: Offshore East and West Coasts of the United States and in the Gulf of Mexico.
- Palmen, E., Quart, J. Roy. Meteorol Soc., 77 337. 1951.
- Pooler, Francis, Jr. "Stable Airflow Patterns at Louisville, Ky.", Presented at Joint Meeting of Amer. Geophys. Union-Amer. Meteorol. Soc., Wash., D.C., April 18-21, 1961.
- Randerson, D., A Comparison of the Spectral Distribution of Solar Radiation in a Polluted and a Clear Air Mass. JAPCA, 20, 8:546-548, Aug., 1970.
- Reynolds, G.W. 1970a: A Practical Look at Tornado Forces. Tech. Paper No. 3, Utah State Univ. Presented Conf. on Tornado Phenomenology and Related Protective Design Measures, Univ. of Wisconsin, April 26-28.
- Smith, T.B., Mirabella, V.A. 1972: Characteristics of California Tornadoes., For University of California, Ernest O. Lawrence Livermore Laboratory, 7 January 1972.
- State of California Air Resources Board, "Climate of the Sacramento Valley Air Basin."

- State of California, Department of Water Resources, 1978 California Snow Survey Measurement Schedule, California Cooperative Snow Surveys, 1978.
- State of California, The Resources Agency, Department of Water Resources, California Sunshine - Solar Radiation Data; May 1978.
- State of California, The Resources Agency, Department of Water Resources, Vegetative Water Use in California, 1974, Bulletin No. 113-3, April 1975.
- Thom, H.C.S., 1970b: Estimate of Maximum Wind Speeds of Tornadoes in Three Northwestern States. Dept. of Geophys. Sci., Univ. of Chicago, SMRP Research Paper No. 92.
- Thom, H.C.S., 1970b: Tornado Force Considerations for Construction Decisions. Utah State Univ., Logan, Utah, 3pp.
- Thom, H.C.S., 1963: Tornado Probabilities. Mon. Wea. Rev., 91, 730-736.
- U.S. Department of Commerce, ESSA, Climates of the States: Climate of California, Climatography of the United States 60-Y., Silver Springs, Maryland.
- U.S. Department of Commerce, ESSA, Climates of the States - Climate of California, Silver Springs, MD, 1970.
- U.S. Department of Commerce, NCC, Supplement 1 to Climate of California, Climatography of the United States No. 60. Asheville, N.C., 1977.
- U.S. Department of Commerce, NOAA, Climatological Data - California, National Climatic Center, Asheville, N.C.
- U.S. Department of Commerce, NOAA, Comparative Climatic Data Through 1976, National Climatic Center, Asheville, N.C.
- U.S. Department of Commerce, NOAA, Local Climatological Data, 1976, Blue Canyon, San Francisco/Federal Office Buildings, San Francisco International Airport, Oakland International Airport, Bishop, Fresno, Stockton, Sacramento, National Climatic Center, Asheville, N.C.
- U.S. Dept. of Commerce, National Oceanic and Atmospheric Administration, National Weather Service, NOAA Atlas II: Precipitation Atlas of the Western United States, Vol. XI - California, Silver Springs, Maryland.
- U.S. Department of Commerce, National Oceanic and Atmospheric Association, TDF-14 Hourly Observations, Monterey, Stockton, Fresno, Bishop California, National Climatic Center, Asheville, N.C.

U.S. Dept. of Commerce, Technical Paper No. 19: Mean Number of Thunderstorm Days in the United States, 1952. Washington, D.C.

U.S. Department of Commerce, Weather Bureau, Summary of Hourly Observations, Sacramento, Fresno, San Francisco, Oakland, California.

U.S. Environmental Protection Agency, "Air Pollution Meteorology", Control Programs Development Division, Research Triangle Park, North Carolina, 1973.

World Wide Airfield Climatic Data, Vol VIII, West Coast, Western Mountains, and Great Basin States.

3.11 GLOSSARY OF TERMS

Abscissa	The horizontal coordinate or axis of any graph; usually denoted by X .
Absorption	The process in which incident radiant energy is retained by a substance.
Advection	The process of transport of an atmospheric property solely by the mass motion (i.e., wind) of the atmosphere.
Air Pollution Meteorology	That aspect of meteorology concerned with atmospheric dispersion characteristics.
Aitken Nuclei	The microscopic particles in the atmosphere which serve as condensation nuclei for droplet growth. These nuclei are both liquid and solid with diameters of tens of microns or smaller.
Albedo	A measure of the part of the incoming solar radiation which is reflected from the earth and the atmosphere.
Annual Moisture Deficit	The moisture deficit of a month is the potential evapotranspiration less the rainfall and stored soil water. The sum of the appropriate months is the annual moisture deficit.
Anticyclone	Movements of air traveling in a clockwise direction (in the northern Hemisphere). Since anticyclone circulation and relative high atmospheric pressure usually coexist, the terms anticyclone and high pressure are often used interchangeably.
Attenuation	The process by which energy decreases with increasing distance from the energy source
Ceiling	The height of the lowest layer of clouds or other obscuring phenomena (e.g., dust). During clear weather, the ceiling is unlimited. With fog, the ceiling is obscured.
Centripetal Acceleration	Acceleration on a particle moving in a curved path, directed toward the center of curvature of the path.
Climate	The average condition of the weather at a place over a period of years as exhibited by temperature, wind velocity, and precipitation.

Compressional Heating	The disturbance of a fluid (e.g., air) such that the pressure and density and, therefore temperature, increase in the direction of motion.
Condensation	The physical process by which a vapor becomes a liquid or a solid.
Condensation Nuclei	A particle, either liquid or solid, upon which condensation of water vapor begins in the atmosphere.
Continental Climate	The climate that is characteristic of the interior of a land mass. It is marked by large annual, daily and day to day ranges of temperature, humidity and precipitation.
Convection	In general, mass motions within a fluid (e.g., air) resulting in transport and mixing of the properties of that fluid.
Cooling Degree	A form of degree day used to estimate the Days energy requirements for air conditioning or refrigeration. One cooling degree-day is given for each degree that the daily mean temperature departs above a base of 75°F.
Coriolis Force	A deflective force resulting from the earth's rotation; it acts to the right of wind direction in the Northern Hemisphere and to the left in the Southern Hemisphere.
Crystallization	A particle which serves as a nucleus in the formation of ice crystals in the atmosphere.
Cumulonimbus	A principal cloud type, exceptionally dense and vertically developed, occurring either as isolated clouds or as a line or wall of clouds with separated upper portions.
Cumulus	A principal cloud type in the form of individual, detached elements which are generally dense and possess sharp non-fibrous outlines.
Cyclones	Movements of air traveling in a counterclockwise direction (in the northern Hemisphere). Since cyclonic circulation and relative low atmospheric pressure usually coexist, the terms cyclone and low pressure system often are used interchangeably.

Cyclonic Storms	Large storm systems (50 to 900 miles in diameter or more) characterized by air rotating around a center of low pressure. More common in winter than summer. Rainfall and snowfall associated with such storms may be light, but may persist for two to three days or longer.
Dew Point	The temperature to which air must be cooled in order for saturation to occur.
Dew Point Depression	The difference between the air temperature and the dew point.
Divergence	The expansion or spreading out of a vector field (e.g., velocity field).
Dry Bulb Temperature	The ambient temperature of the air as measured by a dry-bulb thermometer.
Eddy Viscosity	The turbulent transfer of momentum by eddies (a glob of fluid with a fluid mass that has a life history of its own) giving rise to fluid friction.
Electromagnetic	The ordered array of all known electromagnetic Spectrum radiations, extending from the shortest cosmic rays, through gamma rays, x-rays, ultraviolet light, visible/light, infrared radiation, and including microwave and all other lengths of radio energy.
Electromagnetic Waves	Energy propagated through space or through material media in the form of an advancing disturbance in electric and magnetic fields existing in space.
Evaporation	The physical process by which a liquid or solid is transferred to the gaseous state.
Evapo-transpiration	The combined processes by which water is transferred from the surface of the earth to the atmosphere; <u>evaporation</u> of liquid or solid water plus <u>transpiration</u> from plants.
Exposure	The general surroundings of a site, with special reference to its openness to winds and sunshine.
Fall Velocity	That limited velocity attained by a body freely falling in air when the resisting force is equal to the gravitational force.
First Order Stations	A meteorological station at which automatic records and hourly readings of weather elements are made.

Free Atmosphere	That portion of the earth's atmosphere, above the planetary boundary layer, in which the effects of the earth's surface friction on the air motion are negligible.
Friction Layer	The term is interchangeable with planetary boundary layer and surface boundary layer and refers to the layer between the surface and the free atmosphere.
Frictional Drag	The frictional impedance offered by air to the motion of bodies passing through it.
Front	In meteorology, generally, the interface or transition zone between two air masses of different density.
Frost-Free Period	The frost-free period refers to the length of the growing season as determined by the number of days between the last frost (i.e., 32°F) in spring and the first frost in fall.
Fujita Scale	A scale based upon maximum wind speed to define the intensity of a tornado.
Gradient	The rate of change of a parameter as a function of distance.
Greenhouse Effect	The heating effect exerted by the atmosphere upon the earth by virtue of the fact that the atmosphere absorbs and reemits infrared radiation.
Growing Season	Generally, the period of the year during which the temperature of cultivated vegetation remains sufficiently high to allow plant growth (Usually synonymous with Frost-Free Period).
Heat Island	The accumulation of heat by large, man-made structures such as cities, resulting in considerable differences in temperature in comparison with surrounding areas, particularly at night.
Heating Degree	A form of degree-day used as an indication of fuel consumption; in the United States, one heating degree day is given for each degree that the daily mean temperature departs below a base of 65°F.
Hygroscopic Nuclei	Nuclei with a marked ability to accelerate the condensation of water vapor.

Infrared (Radiation)	Electromagnetic radiation lying in the wavelength interval between visible radiation (light) and microwave radiation.
Inversion	An increase in temperature with height--a reversal of the normal decrease with height in the troposphere; may also be applied to other meteorological properties.
Ions	In atmospheric electricity, any of several types of electrically charged submicroscopic particles normally found in the atmosphere.
Isobars	Lines of equal or constant pressure.
Isohyet	A line drawn through geographical points recording equal amounts of precipitation during a given time period or for a particular storm.
Isothermal	Of equal or constant temperature, with respect to either space or time; more commonly, temperature with height; a zero lapse rate.
Jet Stream	Relatively strong winds concentrated in a narrow stream in the atmosphere.
Julian Days	A calendar system based upon the sequential numbering of each day of the year up to 365 with no monthly delineation.
Killing Frost	The frost sufficiently severe to damage the vegetation of an area. For the purpose of this report, when temperatures are 28°F or less.
Kinetic Energy	The energy which a body possesses as a consequence of its motion.
Lake Evaporation	Evaporation from a lake large enough and deep enough so that evaporation from most of its surface is unaffected by the temperature of the surrounding and underlying land.
Langley	Unit of energy per unit area commonly employed in radiation. One Langley is equal to one gram - calorie per square centimeter. The unit was named in honor of the American scientist, Samuel P. Langley (1834-1906) who made many contributions to the knowledge of solar radiation.
Lapse Rate	The decrease of an atmospheric variable (commonly, temperature) with height.

Latent Heat	The amount of heat absorbed (converted to Kinetic Energy) during the processes of change of liquid water to water vapor, ice to water vapor, or ice to liquid water; or the amount released during the reverse processes. Four such processes are condensation, fusion, sublimation and vaporization.
Leeward	The downwind side of an obstacle.
Marine (also Maritime)	A regional climate which is under the predominant influence of the sea. A marine climate is characterized by small diurnal and annual ranges in temperature.
Mechanical	Turbulence due to the roughness of the surface over which the air is passing.
Mediterranean Climate	A type of climate characterized by hot, dry, sunny summers and a winter rainy season.
Meridional	Longitudinal; northerly or southerly; opposed to zonal.
Meso Scale	That portion of meteorology which deals with atmospheric phenomena on a scale larger than that of micrometeorology but smaller than the cyclonic scale (5 to 50 miles).
Micrometeorology (also, Micro- climatology)	That portion of the science that deals with the observation and exploration of the smallest scale physical and dynamic occurrences within the atmosphere.
Moisture Deficit	The moisture deficit of a month is the potential evapotranspiration less the rainfall and stored soil water.
Molecular Friction	Whenever the surface of one molecule slides over that of another, each molecule exerts a frictional force on the other, parallel to the surfaces.
Norther	A strong, very dry, dusty, northerly wind which blows in late spring, summer and early fall in the Valley of California or in the West Coast when pressure is high over the mountains to the north.
Orographic Lifting	The lifting of an air current caused by its passage up and over mountains.

Palmen's Model	A model describing the general meridional circulation of the earth's atmosphere broken into three cells.
Pan Evaporation	The standard way to measure evaporation of water by using small pans exposed to the atmosphere. The standard Class A land pan is four feet in diameter and ten inches deep, raised six inches from the ground so that air can circulate around it.
Parameter	In general, any quantity that is not an independent variable. The term is often used in meteorology to describe almost any meteorological or climatological quantity or element.
Perturbation	Any departure introduced into an assumed steady state of a system.
Planck's Law	An expression for the variation of monochromatic emittance as a function of wavelength of black-body radiation at a given temperature. It is the most fundamental of the radiation laws.
Pluvial Indices	An index showing the amount of precipitation falling in one day, or other specified period, that is likely to be equalled or exceeded at a given place only once in a given return period (often, 100 years).
Polar Front	The semi-permanent, semi-continuous front separating air masses of tropical and polar origins.
Potential Energy	The energy which a body possesses as a consequence of its position in the field of gravity.
Potential Evapo-transpiration	Combined evaporation from the soil surface and transpiration from plants when the water supply in the ground is unlimited.
Pressure Gradient Force	The force due to differences in pressure within a fluid mass (e.g., air).
Radiational Fog	A major type of fog, produced over a land area where radiational cooling reduces the air temperature to or below its dew-point.
Radiosonde	A balloon-borne instrument for the simultaneous measurement and transmission of meteorological data.

Rainfall Frequency	The number of times during a specific period of years that precipitation of a certain magnitude or greater, occurs or will occur at stations.
Rain Shadow	The region, on the lee side of a mountain or mountain range, where the precipitation is noticeably less than on the windward side.
Rainfall Duration	The length of a rain event.
Rainfall Intensity	The rate of rainfall, usually expressed in inches per hour.
Reflection	The process whereby a surface of discontinuity turns back a portion of the incident radiation into the medium through which the radiation approached.
Roughness	A measure of the irregularity of a surface over which a fluid (e.g., air) is flowing.
Santa Ana	A hot, dry wind generally from the northeast or east, especially below mountain passes in Southern California.
Saturation	The condition in which the partial pressure of a fluid, e.g., air, is equal to its maximum possible partial pressure under existing environmental conditions such that any increase in the amount will initiate a change to a more condensed state.
Saturation Vapor Pressure	The vapor pressure, at a given temperature, wherein the vapor of a substance is in equilibrium with a plane surface of that substance's pure liquid or solid phase.
Scattering	The process by which small particles suspended in the atmosphere diffuse a portion of the incoming solar radiation in all directions.
Sea Breeze	A coastal local wind that blows from sea to land, caused by the temperature difference when the sea surface is colder than the adjacent land.
Sensible Heat	Same as enthalp, which is the measure of heat imparted to a system during a thermodynamic process.
Snow Basin	A term applied to a watershed for the measurement of snow characteristics such as depth, water content, etc.

Snow Course	An established line, usually from several hundred feet to as much as a mile long, transverseing representative terrain in a mountainous region of appreciable snow accumulation.
Snow Pack	The amount of annual accumulation of snow at higher elevations in the Western United States, usually expressed in terms of average water equivalent.
Solar Insolation	The total radiant energy from the sun incident on a unit area of a horizontal plane located at the surface of the earth.
Solar Radiation	The total electromagnetic radiation emitted by the sun.
Squall Line	Any non-frontal line or narrow band of active thunderstorms.
Stagnation Episodes	Periods of poor atmospheric ventilation resulting in the potential for substantial pollutant levels.
Standard Atmosphere	A hypothetical vertical distribution of atmospheric temeperature, pressure and density, which by international agreement is taken to be representative of the global atmosphere (59°F and 29.92 in. of mercury at sea level.
Storm Track	The path followed by a center of low atmospheric pressure.
Stratosphere	The atmospheric layer above the tropopause, average altitude of base and top, 7 and 22 miles respectively; a very stable layer characterized by low moisture content and absence of clouds.
Stratus	A principal cloud type in the form of a gray layer with a rather uniform base.
Supercooled	The reduction of temperature of any liquid below the melting point of that substance's solid phase; that is, cooling beyond its nominal freezing point.
Supersaturation	In meteorology, the condition existing in a given portion of the atmosphere, when the relative humidity is greater than 100 percent.

Synoptic	In general, pertaining to or affording an overall view. In meteorology, it refers to the use of meteorological data obtained simultaneously over a wide area for the purpose of presenting a comprehensive and nearly instantaneous picture of the state of the atmosphere.
Synoptic Scale	Weather patterns associated with high and low pressure systems in the lower troposphere, i.e., large scale.
Terrestrial Radiation	(also called earth radiation, eradiation) The total infrared radiation emitted from the earth's surface.
Thermal Buoyancy	Buoyancy attributable to a local increase in temperature.
Transpiration	The process by which water in plants is transferred as water vapor to the atmosphere.
Tropopause	The transition zone between the troposphere and stratosphere, usually characterized by an abrupt change of lapse rate.
Troposphere	That portion of the atmosphere from the earth's surface to the tropopause; that is, the lowest 6 to 12 miles of the atmosphere. The troposphere is characterized by decreasing temperature with height and by appreciable water vapor.
Tule Fog	A persistent, dense fog common in the Central Valley of California.
Turbulence	A state of fluid flow in which the instantaneous velocities exhibit irregular and apparently random fluctuations so that in practice only statistical properties can be recognized and subjected to analysis.
Ultraviolet (radiation)	Electromagnetic radiation of shorter wavelength than visible light but longer than x-rays.
Water Equivalent	The liquid water present within a sample of snow.
Wavelength	In general, the mean distance between maxima of a roughly periodic pattern (e.g.; light).

Weather The state of the atmosphere mainly with respect to its effects upon life and human activities. As distinguished from climate, weather consists of the short term (minutes to months) variations of the atmosphere. Popularly, weather is thought of in terms of temperature, humidity, precipitation, cloudiness, brightness, visibility and wind.

Wet Bulb Temperature The temperature measured by a wet, muslim-covered bulb thermometer. The temperature an air parcel would have if cooled adiabatically to saturation at constant pressure by evaporation of water into it.

Wind Roses Diagrams designed to show the distribution of wind speed and direction experienced at a given location over a considerable period. The most common form consists of a circle from which 8 or 16 lines emanate, one for each compass point. The length of the line is proportional to the frequency of wind from that direction; the frequency of calms is entered in the center.

Zonal Latitudinal; easterly or westerly; opposed to meridional.

4. DISPERSION METEOROLOGY

4.1 INTRODUCTION

An understanding of the dispersion potential of a region is essential in determining the impact of both existing and proposed sources of ground level and elevated emissions of pollutants. Areas that are plagued with poor dispersion conditions for extended periods of time are apt to suffer stringent limitations on land use and industrial development. Under such poor dispersion conditions, seemingly insignificant sources of pollution can result in excessive concentrations over large areas. As discussed in Section 6, The Clean Air Act Amendments of 1977 impose strict regulatory requirements on new sources of air pollution in areas with high ambient pollutant concentrations.

The dispersion potential within the Susanville District has been developed through the maximum utilization of available data. The following sections describe the dispersion meteorology of the Susanville District in terms of the following analyses:

- Data Sources
- Prevailing Winds
- Atmospheric Stability
- Mixing Heights and Inversions
- Typical and Worst-Case Conditions
- Air Basins
- Fire Weather
- General Dispersion Modeling

Surface data suitable for use in the analysis of the Susanville District dispersion meteorology are derived primarily from the National Weather Service (NWS) first-order meteorological stations. The availability of mixing height, inversion and winds aloft data is limited to those stations that take routine measurements of upper air winds and temperatures. Oakland is the only NWS station of this type in the District. However, upper air winds and temperature data are also available at other sites as part of a program being conducted by the California Air Resources Board (CARB). Additional data from lower-order NWS or other governmental and special interest stations have been reviewed and included where they provide additional significant information regarding the characterization of the dispersion meteorology of the Susanville District.

Section 4.2 provides a review of the general principles of dispersion meteorology. Sources of data which have been used to describe the dispersion potential of the Susanville District are discussed in Section 4.3. The discussion then turns to a review of specific dispersion parameters including prevailing winds, atmospheric stability, mixing heights, and inversions in Sections 4.4 through 4.6, respectively. More detailed analyses are then provided, including a review of typical and worst-case

conditions for a variety of potential sources in Section 4.7. The air basin analysis approach to dispersion meteorology is outlined in Section 4.8. Section 4.9 provides a discussion of the impact of dispersion meteorology on burn conditions while section 4.10 describes concepts of air quality modeling including suggestions as to the manner in which the data presented in this document should be interfaced with appropriate models. Finally, Section 4.11 provides a review of sources of assistance to BLM personnel encountering problems in dispersion meteorology while Section 4.12 provides a glossary of terms.

4.2 PRINCIPLES OF DISPERSION METEOROLOGY

Dispersion meteorology provides an evaluation of the capability of the atmosphere to disperse airborne effluents in a given geographical region. That capability depends largely on the critical meteorological parameters wind speed and direction, atmospheric stability and mixing height. The topography of the region also plays an important role.

The air pollution cycle can be considered to consist of three phases: the release of air pollutants at the source, the transport and diffusion in the atmosphere, and the reception of air pollutants in reduced concentrations by humans, plants, animals, or inanimate objects. The major influence of meteorology occurs during the diffusion and transport phase. The motions of the atmosphere which may be highly variable in four dimensions, are responsible for the transport and diffusion of air pollutants.

Although the distribution of a cloud of pollutant material with time will depend on the summation of all motions of all sizes and periods acting upon the cloud, it is convenient to first consider some mean atmospheric motions over periods on the order of an hour.

The following sections discuss (1) the principles of turbulence and diffusion, (2) the key dispersion parameters, (3) the role of topography in diffusion and (4) atmospheric chemistry. Modeling is discussed in detail in Section 4.9 while instrumentation is reviewed in Section 7.

4.2.1 Principles of Turbulence and Diffusion

When a small concentrated puff of gaseous pollutant is released into the atmosphere, it tends to expand in size due to the dynamic action of the atmosphere. In so doing, the concentration of the gaseous pollutant is decreased because the same amount of pollutant is now contained within a larger volume. This natural process of high concentrations spreading out to lower concentrations is the process of diffusion.

Atmospheric diffusion is ultimately accomplished by the wind induced movement of pollutants, but the character of the source of pollution requires that this action of the wind be taken into account in different ways. These sources can be conveniently grouped into three classes: point sources, line sources, and area sources. In practice, the first two classes must be further divided into instantaneous and continuous sources.

The instantaneous point source is essentially a "puff" of material created or ejected in a relatively short time, as by a nuclear explosion, the sudden rupture of a chlorine tank, or the bursting of a tear-gas shell. The wind of immediate impor-

tance is, of course, that occurring at the place and time at which the pollutant is created. Since the wind is highly variable, the initial direction of movement of the puff is also variable and difficult to predict; a soap-bubble pipe and five minutes' close observation of the initial travel of successive bubbles will convincingly demonstrate the difficulty of predicting the exact trajectory of the next bubble. In addition, dilution of a puff source is a very strong function of time after its release. At first, the small-scale fluctuations of the wind cause it to grow rather slowly and the larger-scale wind variations simply carry it along on erratic paths. But as the puff grows, larger-scale motions can get a "hold" on it to tear it apart and dilute it more rapidly. Thus, the unique feature of the instantaneous point source is its increasing dispersion rate with time, hence, the necessity to consider successively larger scales of meteorological phenomena in calculating its spread.

Continuous point sources (the smoke plume from a factory chimney, the pall from a burning dump) are the most familiar, the most conspicuous, and the most studied of all pollution sources. The meteorology of the continuous source must take into account the time changes of the wind at the point of emission. The behavior of a plume from a factory chimney is very much like that of water from a hose being played back and forth across a lawn. It is evident that if the hose is steady, the same area will be continually exposed to the water. But if the hose (wind) moves back and forth in an arc, the water (pollution) will be distributed over a wider area, hence the concentration will be less. For a truly continuous source, there are other changes of great importance - primarily the diurnal and seasonal cycles.

The isolated line source is less common, and therefore, of less general interest, with two important exceptions - heavily traveled highways, and the swath of chemicals emitted by crop-dusting apparatus. In both these examples, if the line of pollutant is uniform and is long enough, the dispersion of the pollution must be attained in only two dimensions, along the wind and in the vertical. If the line source is a continuous one, as might be the case of a freeway in rush hours, spreading in the downwind direction becomes ineffective (at a particular downwind location), so that only the vertical dimension is left to provide dilution. This behavior of the continuous line source has been exploited by meteorologists in field experiments with controlled tracers to permit the detailed study of vertical diffusion, uncomplicated by effects in the other two coordinates.

The area source can vary enormously in size. It may be distributed over several square miles, as in an industrial park, over tens or hundreds of square miles, as in a city, or over thousands of square miles, exemplified by the almost-continuous strip city (the "megalopolis" or "megapolitan area") along the eastern seaboard of the United States. These area sources usually include combinations of all the single-source configurations. A large city will include many thousands of home chimneys, thou-

sands of factories and shops, hundreds of miles of streets, open dumps, burning leaves, evaporating fumes from gasoline storage or from cleaning plants and paint factories, and everywhere the automobile. The weather problem of the city area source becomes, in the aggregate, quite different from that of a single source. Here we are concerned not with the increasing rate of wind dispersion with increasing scale, or with the behavior of wind with time at a single point, but rather with the replenishment rate of the air over the city. We must consider the total movement of a large volume of air as it "ventilates" the city. Anything that reduces this ventilation rate, whether it be the confining effect of surrounding mountains or the reduced velocities of a slow-moving anticyclone, is of concern.

In the construction of cities man has modified the weather as will be discussed in more detail in Section 4.2.6. The volume of effluent injected into the air has reduced the solar radiation. The absorption characteristics of cement and asphalt instead of grass and trees create urban "heat islands." These effects must be considered in the meteorology of urban air pollution. The urban heat island effect is discussed in more detail in Section 3.9.

The atmosphere disperses pollutants because it is in constant motion, and this motion is always turbulent to some degree. There is, as yet, no fully accepted definition of turbulence, but empirically it can be described as random (three-dimensional) flow. The understanding of turbulent diffusion in the atmosphere has progressed largely through empirical treatments of controlled tracer experiments. The current tendency is to deal with turbulence through statistical concepts derived from aerodynamics and fluid dynamics, in contrast to earlier theories which centered around a virtual-diffusivity concept. In the practical application of computing pollution concentrations, the common practice is to employ the statistical method for distances to perhaps 150 kilometers (93 miles) from the source, and equations based on virtual-diffusivity ("K") theory for longer distances, particularly for calculations on a hemispheric or global scale.

Vertical Turbulent Diffusion

To all intents and purposes rapid atmospheric diffusion in the vertical is always bounded: on the bottom by the surface of the earth and at the top by the tropopause. The tropopause - the demarcation between the troposphere, where temperature decreases with altitude, and the stratosphere, where the temperature is relatively constant or increases with altitude - is lowest over the poles, at about 5 miles, and highest in the tropics, at about 12 miles. The full depth of the troposphere is available for vertical dispersion. However, utilization of this total vertical dimension can take place at very different rates, depending on the thermally driven vertical wind. These rates are intimately related to the vertical temperature profile. On the

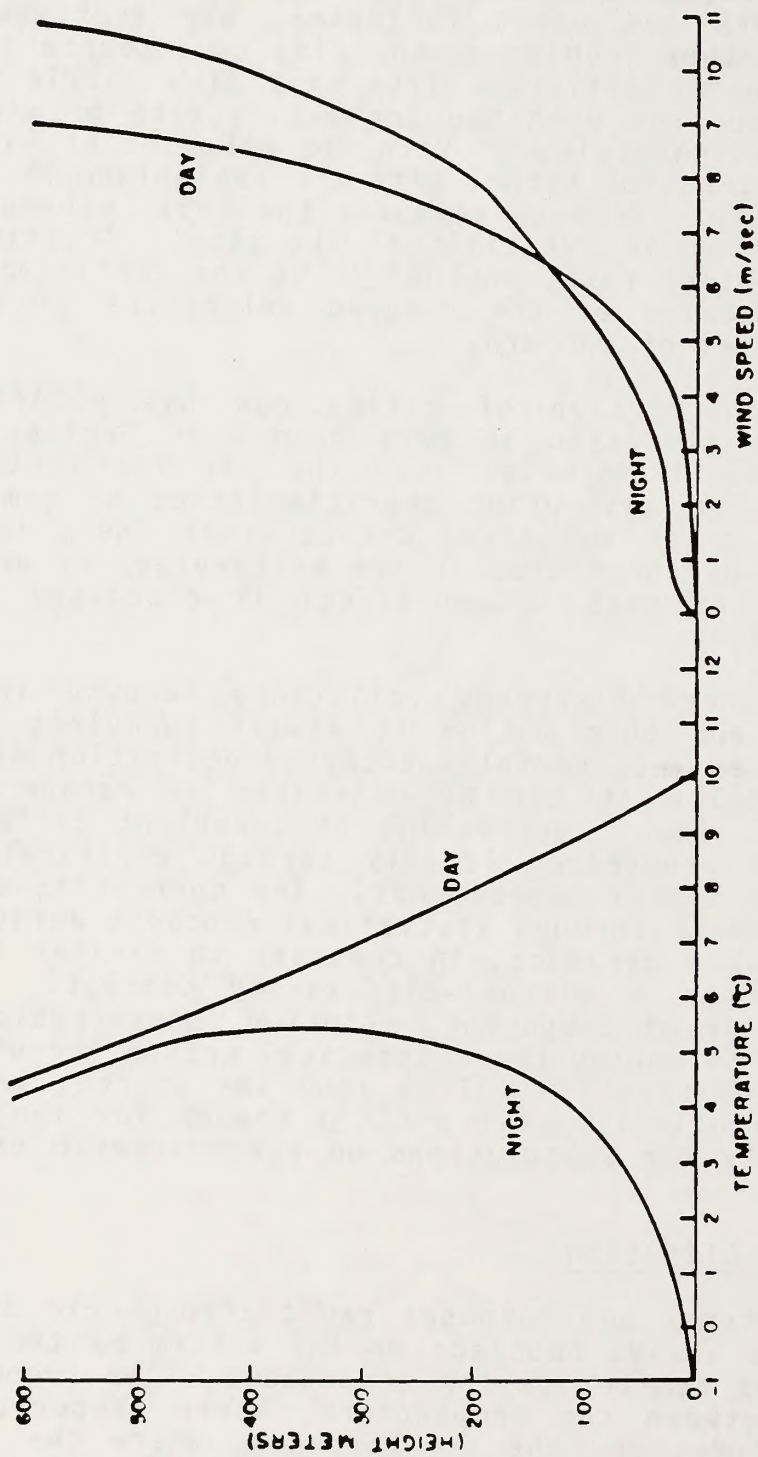

Figure 4.2-1
Diurnal Variation of Temperature and Wind Speed

average (and if we neglect the effects of the phase change of water in the air), enhanced turbulence is associated with a drop in temperature with height of 10°C per kilometer (29°F per mile) or greater (this is the dry adiabatic rate as discussed in Section 4.2.3). If the temperature change with height is at a lesser rate, turbulence tends to be decreased, and if the temperature increases with height (an "inversion"), turbulence is very much reduced.

The temperature profiles particularly over land, show a large diurnal variation as seen in Figure 4.2-1. Shortly after sunrise, the heating of the land surface by the sun results in rapid warming of the air near the surface; the reduced density of this air causes it to rise rapidly. Cooler air from aloft replaces the rising air "bubble," to be warmed and rise in turn. This vigorous vertical interchange creates a "super-adiabatic" lapse rate - a temperature decrease of more than 29°F per vertical mile - and vertical displacements are accelerated. The depth of this well-mixed layer depends on the intensity of solar radiation and the radiation characteristics of the underlying surface. Over the deserts, this vigorous mixing may extend well above 2 miles, while over forested lake country, the layer may be only from three to seven hundred feet thick. Obviously, this effect is highly dependent on season; in winter, the lesser insolation and unfavorable radiation characteristics of snow cover greatly inhibit vertical turbulence.

In contrast, with clear or partly cloudy skies the temperature profile at night is drastically changed by the rapid radiational cooling of the ground and the subsequent cooling of the layers of air near the surface. This creates an "inversion" of the daytime temperature profile, since there is now an increase in temperature with height. In such a situation the density differences rapidly dampen out vertical motions, which tends to reduce vertical turbulence, and stabilize the atmosphere.

Two other temperature configurations, on very different scales, have important effects on vertical turbulence and the dilution of air pollution. At the smaller end of the scale, the heat capacity of urban areas and, to a lesser extent, the heat generated by fuel consumption act to modify the temperature profile. The effect is most evident at night, when the heat stored by day in the buildings and streets warms the air and prevents the formation of the surface-based temperature inversions typical of rural areas. Over cities, it is rare to find inversions in the lowest 300 feet; the city influence is usually evident 700 to 1000 feet above the surface. The effect is a function of city size and building density, but not enough observations are yet available to provide any precise quantitative relations. Although the effect even for the largest cities is probably insignificant above three thousand feet, this locally produced vertical mixing is quite important. Pollution, instead of being confined to a narrow layer near the height of emission,

perhaps only 300 feet in thickness, can be freely diluted in more than double the volume of air, the concentrations being reduced by a similar factor.

On a much larger scale the temperature profile can be changed over thousands of square miles by the action of large-scale weather systems. In traveling storm systems (cyclones), the increased pressure gradients and resulting high winds, together with the inflow of air into the storm, create relatively good vertical mixing conditions. On the other hand, the flat pressure patterns, slower movement, and slow outflow of surface air in high-pressure cells (anticyclones) result in much less favorable vertical mixing. This is primarily due to the gradual subsidence of the air aloft as it descends to replace the outflow at the surface. During this descent, the air warms adiabatically, and eventually there is created a temperature inversion aloft, inhibiting the upward mixing of pollution above the inversion level. As the anticyclone matures and persists, this subsidence inversion may lower to very near the ground and persist for the duration of the particular weather pattern.

Horizontal Turbulent Diffusion

The most important difference between the vertical and horizontal dimensions of diffusion is that of scale. In the vertical, rapid diffusion is limited to about 10 kilometers (6 miles). But in the horizontal, the entire surface of the globe is eventually available. Even when the total depth of the troposphere is considered, the horizontal scale is larger by at least three orders of magnitude, and the difference, say during a nocturnal inversion which might restrict the vertical diffusion to within a hundred feet, is even greater since the lateral turbulence is reduced less than the vertical component. Mechanically produced horizontal turbulence is, on a percentage basis, much less important than the thermal effects; its effects are of about the same order of magnitude as the vertical mechanical effects.

The thermally produced horizontal turbulence is not so neatly related to horizontal temperature gradients as vertical turbulence is to the vertical temperature profile. The horizontal temperature differences create horizontal pressure fields, which in turn drive the horizontal winds. These are acted upon by the earth's rotation (the Coriolis effect) and by surface friction, so that there is not such a thing as a truly steady-state wind near the surface of the earth. Wind speeds may vary from nearly zero near the surface at night in an anticyclone, to 200 miles per hour under the driving force of the intense pressure gradient of a hurricane. The importance of this variation, even though in air pollution we are concerned with much more modest ranges, is that for continuous sources the concentration is inversely proportional to the wind speed.

The variation of turbulence in the lateral direction is

perhaps the most important factor of all and certainly one of the most interesting. In practice, this can best be represented by the changes in horizontal wind direction illustrated in Figure 4.2-2. Within a few minutes, the wind may fluctuate rapidly through 90 degrees or more. Over a few hours it may shift, still with much short-period variability, through 180 degrees, and in the course of a month it will have changed through 360 degrees numerous times. Over the seasons, preferred directional patterns will be established depending upon latitude and large-scale pressure patterns. These patterns may be very stable over many years, and thus establish the wind climatology of a particular location.

The emitted pollution travels with this ever-varying wind. The high-frequency fluctuations spread out the pollutant, and the relatively steady "average" direction carries it off - for example, toward a suburb or a business district. A gradual turning of direction transports material toward new targets and gives a respite to the previous ones. Every few days the cycle is repeated, and over the years the prevailing winds can create semipermanent patterns of pollutions downwind from factories or cities.

4.2.2 Prevailing Winds

Wind speed and direction play a fundamental role in the dispersion of airborne contaminants. The following paragraphs discuss wind speed and direction and other wind characteristics and their associated impact on local and regional dispersion potential.

Mean wind direction has a basic impact on air pollutant levels. If the wind direction is representative of the height at which the pollutant is released, the mean direction will be indicative of the direction of travel of the pollutants. In meteorology, it is conventional to consider the wind direction as the direction from which the wind blows, therefore, a northwest wind will move pollutants to the southeast of the source.

The effect of wind speed is two-fold. The wind speed will determine the travel time from a source to a given receptor, e.g., if a receptor is located 1000 meters (3281 ft) downwind from a source and the wind speed is 5 meters/second (16.4 ft/sec), it will take 200 seconds for the pollutants to travel from the source to the receptor. The other effect of wind speed is a dilution in the downwind direction. If a continuous source is emitting a certain pollutant at the rate of 10 grams/second (1.3 lbs/min) and the wind speed is 1 meter/second (2.2 mph) then in a downwind length of the plume of 1 meter (3.3 feet) will be contained 10 grams (0.02 lbs) of pollutant since 1-meter (3.3 feet) of air moves past the source each second. Next, consider that the conditions of emission are the same but the wind speed is 5 meters/second (11 mph). In this case, since 5 meters (16.4 feet) of air moves past the source each second, each meter of

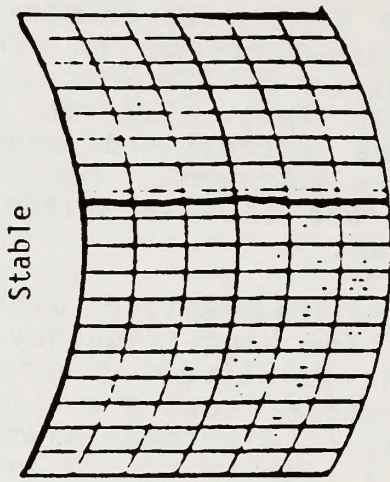
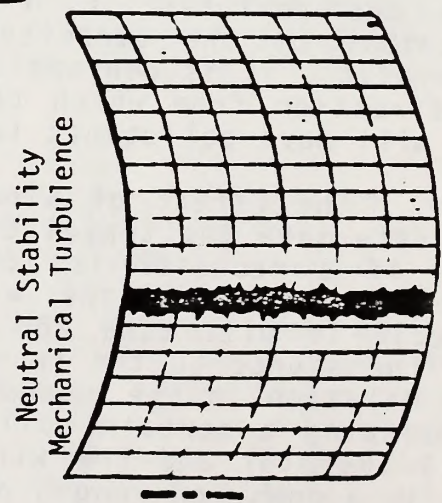
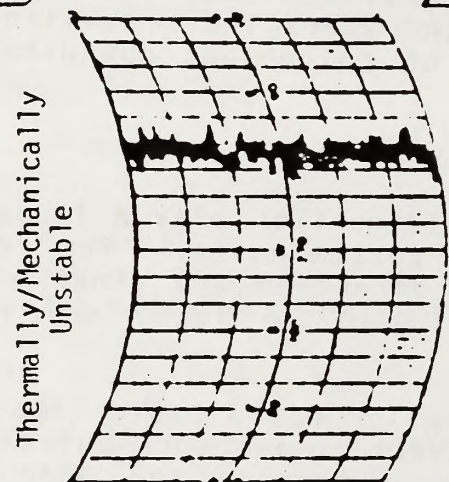
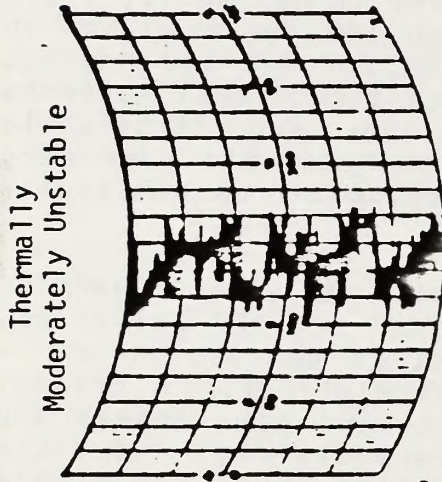
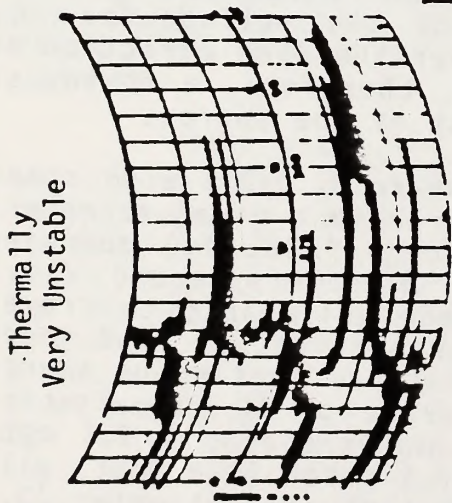

Figure 4.2-2
Gustiness Classification

plume length contains 2 grams (0.04 lbs) of pollutant. Therefore, it can be seen that the dilution of air pollutants released from a source is proportional to the wind speed. This may be restated in another form: The concentration of air pollutants is inversely proportional to wind speed.

Wind speed is generally found to increase with height above the ground and wind direction to veer (turn clockwise) with height (in the northern hemisphere at extratropical latitudes) due to the effects of friction with the earth's surface. The amount of these increases in speed and veering in direction are quite variable, and to a great degree, related to the roughness of the surface and the stability of the atmosphere.

In the preceding paragraphs, consideration of only the mean speed and direction of wind has been made. Of course, there are deviations from these means. There are velocity components in all directions creating vertical motions as well as horizontal ones. These random motions of widely different scales and periods are essentially responsible for the movement and diffusion of pollutants about the mean downwind path. These motions, commonly called eddies, are considered as atmospheric turbulence. If the scale of a turbulent motion, i.e., the size of an eddy, is larger than the size of the pollutant plume in its vicinity, the eddy will move that portion of the plume. If an eddy is smaller than the plume, its effect will be to diffuse or spread out the plume. This diffusion caused by the eddy motion is widely variable, but even when this diffusion is at the minimum, it is roughly three orders of magnitude greater than the diffusion by molecular action alone.

During the daytime, solar heating causes turbulence to be at a maximum and vertical motions to be strongest. This causes the maximum amount of momentum exchange between various levels in the atmosphere. Because of this, the variation of wind speed with height is least during the daytime. Also, the amount of veering with height is least (on the order of 15° to 20° over average terrain). The thickness of the friction layer will also be greatest during the day due to the vertical exchange.

At night, the vertical motions are least and the effect of friction is not felt through as deep a layer as during the day. The surface speed over average terrain is much less than the free atmosphere wind (on the order of $1/4$ to $1/3$ that of the 1000 meter (3281 feet) wind) and the amount of veering with height may be on the order of 40° to 45° . Figure 4.2-3 shows the diurnal variation of wind speed at two different levels on a meteorological tower (Singer and Raynor, 1957).

Wind data are generally only available in terms of speed and direction. Turbulence data are considerably more sophisticated and are generally only available as a result of specialized, site-specific data gathering programs. Such data are only used in very detailed modeling analyses. The bulk of the model-

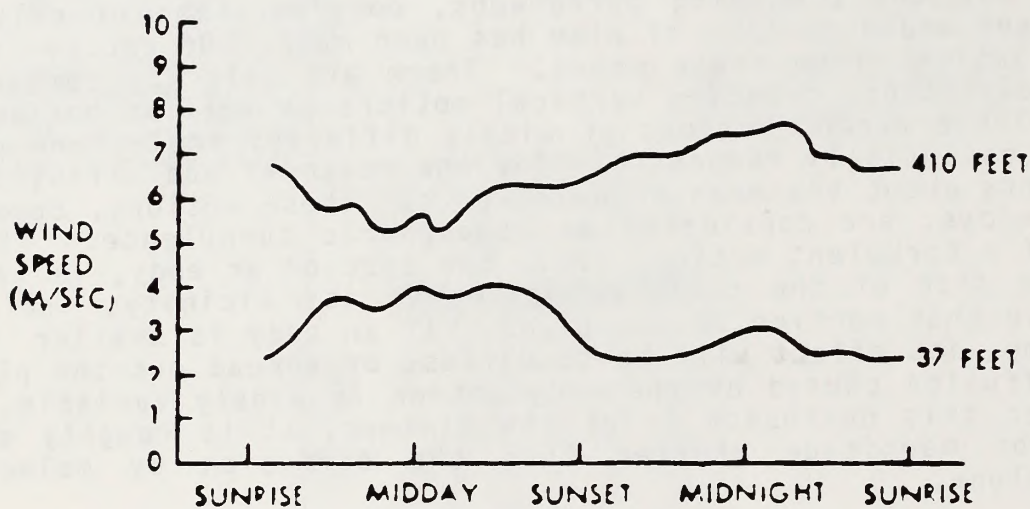

Figure 4.2-3
 Diurnal Variations in Wind Speed
 As a Function of Height (1)

(1) Data from Meteorological Tower
 Brookhaven National Laboratory
 April 1950-March 1952

ing analyses conducted for the air pollution industry require only basic wind data for speed and direction. This latter type of data are generally summarized in the form of wind roses. These may be viewed in Figure 4.4-1.

A wind rose is defined in the Glossary of Meteorology as, "Any one of a class of diagrams designed to show the distribution of wind direction experienced at a given location over a considerable period; it thus shows the prevailing wind direction. The most common form consists of a circle from which eight or sixteen lines emanate, one for each compass point. The length of each line is proportional to the frequency of wind from that direction; and the frequency of calm conditions is entered in the center. Many variations exist. Some indicate the range of wind speeds from each direction; some relate wind direction with other weather occurrences." Wind roses may be constructed for data from a given time period such as a particular month or may be for a particular time of day or season from a number of years of data. In constructing or interpreting wind roses, it is necessary to keep in mind the meteorological convention that wind direction refers to the direction from which the wind is blowing. A line or bar extending to the north on a wind rose indicates the frequency of winds blowing from the north, not the frequency of winds blowing toward the north. Some of the specialized wind roses that may be constructed are precipitation wind roses, stability wind roses, and pollution wind roses. The latter two require additional data than are generally available at standard Weather Bureau stations. An informative article on the history and variants of wind roses has been published by Court (1963).

Prior to January 1964, the surface wind direction was reported by U.S. Weather Bureau stations as one of the 16 directional points corresponding to the mariner's compass card or compass rose, on which each direction is equivalent to a 22-1/2 sector of a 360° circle. Table 4.2-1 illustrates, in the form of a frequency table of wind direction versus wind speed groups, the data essential to the development of a 16-point wind rose. It is an example of summaries of hourly observations published monthly until January 1964 in the Local Climatological Data (LCD) Supplement. Frequencies are totaled by direction and wind speed group. A quick look at this wind rose indicates the highest directional frequency is from the ENE and the highest speed frequency is the 8 to 12 mph column. Average speeds have been computed for each direction.

When wind roses are employed to summarize climatological data involving long periods of record, percentage frequencies are favored over numerical totals for tabular presentation since the number of observations in any one cell can become quite large. Moreover, wind rose diagrams can be drafted directly from tabular data if percentages are available. Table 4.2-2 presents 10 years of hourly wind data observed at New Orleans Moisant International Airport during January for the years 1951 through 1960, as published in the "Decennial Census of United States Climate." This

Table 4.2-1
A Typical Tabular 16 Point Wind Rose

DIRECTION	HOURLY OBSERVATIONS OF WIND SPEED										AVERAGE SPEED	
	0-3	4-6	7-10	KNOTS		22-27	28-33	34-40	40 Over	TOTAL	KNOTS	M.P.H.
	0-3	4-7	8-12	11-16	17-21	25-31	32-38	39-46	47 Over			
N	8	13	15	18	12	3				69	10.8	12.4
NNE	1	16	28	30	7	1				83	10.2	11.7
NE	7	34	36	5						82	6.7	7.7
ENE	11	51	46	5						113	6.3	7.3
E	6	19	14	4						43	6.4	7.3
ESE	4	15	13	3						35	6.5	7.5
SE	1	13	4	2						20	6.3	7.2
SSE	2	6	20	11						39	8.3	9.6
S	3	11	21	10	1					46	8.2	9.4
SSW	3	9	9	9	4					34	9.3	10.6
SW	1	8	7							16	6.3	7.2
WSW		4	3	1						8	6.9	7.9
W	1	5	7							13	6.5	7.4
WNW	1	16	6	1						24	6.0	6.9
NW	2	3	6	1						12	7.2	8.2
NNW	1	11	29	26	6	1				74	10.6	12.2
CALM	33									33	0.0	0.0
TOTAL	85	234	264	126	30	5				744	7.7	8.9

Table 4.2-2
 Sample Long-Term Wind Rose Data for
 New Orleans, Louisiana

DIRECTION	HOURLY OBSERVATIONS OF WIND SPEED										M.P.H.	
	0-3	4-7	8-12	13-18	19-24	25-31	32-38	39-46	47 OVER	TOTAL		
N	+	1	2	3	1	+	+	+			7	13.9
NNE	+	1	2	3	1	+					6	12.8
NE	+	2	3	3	+	+					8	11.0
ENE	+	2	4	2	+	+					8	9.9
E	+	2	3	1	+						6	9.1
ESE	+	1	1	1							3	8.4
SE	+	2	2	+	+						5	7.8
SSE	+	3	3	1	+	+		+			9	9.9
S	+	3	4	2	+	+					10	9.8
SSW	+	1	3	2	1	+					7	12.0
SW	+	1	1	+	+	+					3	8.6
WSW	+	1	1	+	+	+	+				2	10.7
W	+	1	1	1	+	+	+	+			2	11.8
WNW	+	1	1	1	+	+	+	+			3	12.5
NW	+	1	1	1	1	+	+	+			5	13.9
NNW	+	1	2	2	2	1	+	+			8	14.7
CALM	8										8	
TOTAL	11	22	34	23	7	2	+	+			100	10.3

10-year summary of meteorological data is compiled for most U.S. Weather Bureau first order stations.

On January 1, 1964, the U.S. Weather Bureau changed the wind direction reporting procedure from 16 points to 36 - 10° intervals. Table 4.2-3 is the result; a 36-point wind rose. Since 36 cannot be divided by 16 there is no way of grouping 36 points into 16 points and there is no easy way of combining wind data if the wind rose summaries include both 16-point and 36-point wind direction observations. For this and other reasons, the 36-point wind rose was dropped after 1964. A few air quality models such as CRSTER require 36 point wind rose data, and for such an application, 1964 data must be used.

This report will present wind roses using a very simplistic format. The frequency of the wind direction for each of the 16 cardinal directions is plotted and lines are drawn connecting each directional frequency (See Section 4.4.1)

4.2.3 Atmospheric Stability

Whether the atmosphere has a tendency to enhance or to dampen out vertical motions is important to atmospheric processes which produce weather as well as to the effects upon air pollutant dispersion. The stability of the atmosphere is highly dependent upon the vertical distribution of temperature with height.

Adiabatic Lapse Rate

Due to the decrease of pressure with height, a parcel of air lifted to higher altitude will encounter decreased pressure and expand and, in undergoing this expansion, will cool. If this expansion takes place without loss or gain of heat to the parcel, the change is adiabatic. Similarly, a parcel of air forced downward in the atmosphere, will encounter higher pressures, contract, and become warmer. This rate of cooling with lifting, or heating with descent is the dry adiabatic lapse rate and equals 5.4°F per 1000 feet or approximately 1°C per 100 meters. This process lapse rate is the rate of heating or cooling of any descending or rising parcel of air in the atmosphere and should not be confused with the existing temperature variation with height at any one time, i.e., the environmental lapse rate.

Environmental or Prevailing Lapse Rate

The manner in which temperature changes with height at any one time is the environmental or prevailing lapse rate. This is principally a function of the temperature of the air and of the surface over which it is moving and the rate of exchange of heat between the two. For example, during clear days in mid-summer the ground is rapidly heated by solar radiation. This in turn, provides for rapid heating of the layers of the atmosphere nearest the surface. Further aloft, however, the atmospheric

Table 4.2-3
A Typical Tabular 36 Point Wind Rose

DIRECTION	HOURLY OBSERVATIONS OF WIND SPEED											AVERAGE SPEED	
	0-3	4-6	7-10	11-16	KNOTS 17-22 M.P.H. 19-24	22-27 25-31	28-33 32-39	34-40 40-46	41 OVER 47 OVER	TOTAL	KNOTS	M.P.H.	
	0-3	4-7	8-12	13-18									
01	3	5	2	3						13	6.9	8.0	
02	7	9	8							24	5.3	6.0	
03	3	9	7							19	5.4	6.2	
04	7	22	2	1						32	5.3	6.1	
05	9	15	7	4						35	5.9	6.8	
06	11	27	17	6						61	6.2	7.1	
07	4	27	16	3						50	6.2	7.1	
08	3	7	13	3						26	7.2	8.3	
09	1	9	6	5						21	7.7	8.8	
10	5	9	4							18	5.1	5.8	
11	5	11	5	1						22	5.8	5.5	
12	5	5	4							14	5.9	5.7	
13	2	4	3							9	6.0	6.9	
14	5	7	6							18	5.2	6.0	
15	1	7	5		1					14	7.1	8.1	
16	1	8	4							13	5.9	6.8	
17	1	6	4							11	6.2	7.1	
18		6	9	6						21	8.8	10.1	
19	2	2	3	5						7	5.7	6.6	
20	3	5	7	1						15	7.1	5.1	
21	2	2	3	1						8	6.6	7.6	
22	2	2	5	6						15	8.6	9.9	
23	4	2	7	3						16	7.3	8.3	
24	5	2	2	1						10	5.3	6.1	
25	3	1	1	1						5	5.0	5.8	
26	2	3	4	4						13	7.6	8.8	
27	2	6	1							9	5.0	5.8	
28	3	5	4							12	5.5	6.3	
29		2	9	7						18	9.7	11.2	
30		3	4	7						14	10.1	11.7	
31	2	2	2	12						18	10.3	11.9	
32	2	3	12	10						28	9.9	11.4	
33	1	7	9	13	1					30	9.4	10.8	
34	1	2	11	11						25	9.6	11.0	
35	3	1	1	2						7	6.7	7.7	
36	4	6	8	2						20	7.0	8.1	
00	53									53	0.0	0.0	
TOTAL	167	249	209	117	2				744	6.4	7.4		

temperature will remain relatively unchanged. Conversely, at night, radiation from the earth's surface cools the ground and the air adjacent to it, resulting in only slight decrease of temperature with height, and in cases when the surface cooling is great enough, temperature may increase with height. This atmosphere is considered stable.

If the temperature decreases more rapidly with height than the dry adiabatic lapse rate, the air has a super-adiabatic or strong lapse rate and the air is unstable. If a parcel of air is forced upwards it will cool at the adiabatic lapse rate, but will still be warmer than the environmental air. Thus it will continue to rise. Similarly, a parcel which is forced downward will heat dry adiabatically but will remain cooler than the environment and will continue to sink.

For environmental lapse rates that decrease with height at a rate less than the dry adiabatic lapse (sub-adiabatic or weak lapse) a lifted parcel will be cooler than the environment and will sink; likewise, a descending parcel will be warmer than the environment and will rise. Figure 4.2-4 shows the relative relation between the environmental lapse rates of super-adiabatic (strong lapse), sub-adiabatic (weak lapse), isothermal, and inversion with the dry adiabatic process lapse rate presented as dashed lines.

Lifting motions which promote cooling at dry adiabatic lapse rates may be caused by upslope motion over mountains or warmer air rising over a colder air masses. Descending motion (subsidence) may occur to compensate for the lateral spreading of air in high pressure areas.

Classification Schemes

The dispersive power of the atmosphere can be categorized into seven classes, labeled stability categories, in accordance with a method proposed by Pasquill (1962) and modified by Gifford (1961) and Markee (1966). Pasquill's first three classes, A, B, and C, range from extreme to slight instability. Class D represents neutral or well-mixed conditions, while E and F represent slight and moderate stability, respectively. Dispersive power decreases with progression through these classes. Markee (1966) has further divided the original class F into classes F and G, with G representing extreme stability. For the purpose of simplifying the presentation, classes A, B, and C have been combined, in some instances, to form one category called unstable. Similarly, class D will be referred to as the neutral category, and classes E, F, and G together form the stable category.

The stability of the atmosphere is determined by various methods using numerous forms of meteorological data. A frequently used means of assessing ambient atmospheric stability is through the measurement of changes in atmospheric temperature

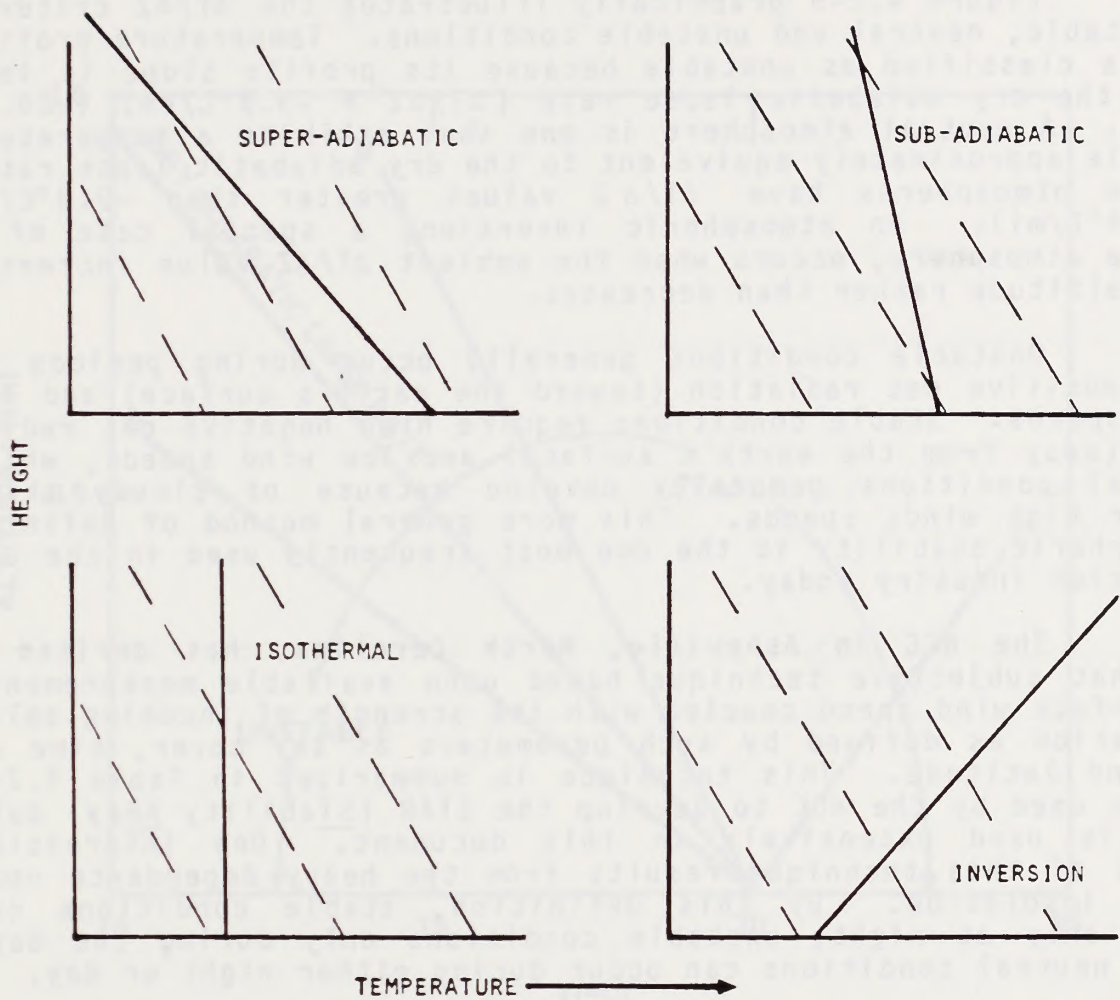

Figure 4.2-4
Types of Temperature Structure with Height Related to
the Dry Adiabatic Process Lapse Rate

with altitude ($\Delta T/\Delta Z$) above an area in question. This is accomplished by probing the atmosphere with specialized temperature sensors mounted on aircraft, balloons, or on tall meteorological towers.

Figure 4.2-5 graphically illustrates the $\Delta T/\Delta Z$ criteria for stable, neutral and unstable conditions. Temperature profile "A" is classified as unstable because its profile slope is less than the dry adiabatic lapse rate ($\Delta T/\Delta Z = -9.8^\circ\text{C}/\text{km}$) ($-28.4^\circ\text{F}/\text{mi}$). A neutral atmosphere is one that exhibits a temperature profile approximately equivalent to the dry adiabatic lapse rate. Stable atmospheres have $\Delta T/\Delta Z$ values greater than $-9.8^\circ\text{C}/\text{km}$ ($-28.4^\circ\text{F}/\text{mi}$). An atmospheric inversion, a special case of a stable atmosphere, occurs when the ambient $\Delta T/\Delta Z$ value increases with altitude rather than decreases.

Unstable conditions generally occur during periods of high positive net radiation (toward the earth's surface) and low wind speeds. Stable conditions require high negative net radiation (away from the earth's surface) and low wind speeds, while neutral conditions generally develop because of cloudy skies and/or high winds speeds. This more general method of defining atmospheric stability is the one most frequently used in the air pollution industry today.

The NCC in Asheville, North Carolina, has devised a somewhat subjective technique based upon available measurements of surface wind speed coupled with the strength of incoming solar insolation as defined by such parameters as sky cover, time of day and latitude. This technique is summarized in Table 4.2-4 and is used by the NCC to develop the STAR (STability ARay) data that is used extensively in this document. One interesting aspect of this technique results from the heavy dependence upon solar insolation. By this definition, stable conditions can occur only at night, unstable conditions only during the day, while neutral conditions can occur during either night or day.

The Influence Of Vertical Temperature Structure Upon Plume Behavior

The manner in which stack effluents diffuse is primarily a function of the stability of the atmosphere. Church (1949) has typified the behavior of smoke plumes into five classes. Hewson (1960) has added a sixth class, taking into account inversions aloft (Inversions will be discussed in more detail in section 4.2.4). Figure 4.2-6 depicts each class and the appropriate dispersion characteristics for an idealized chimney. The Pasquill stability classes are also noted.

Looping

Looping occurs with a super-adiabatic lapse rate. Large thermal eddies are developed in the unstable air and high concentrations may be brought to the ground for short time intervals.

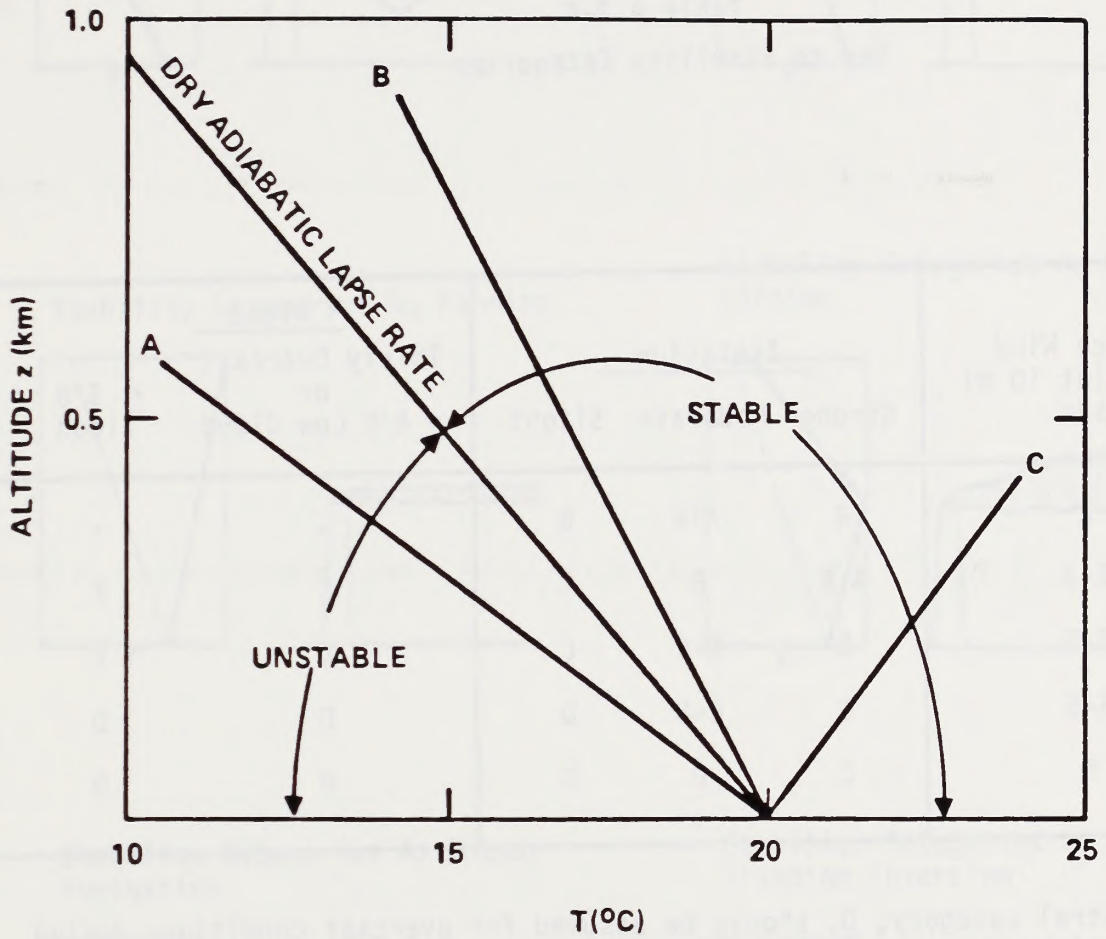

Figure 4.2-5
 Temperature Profiles which are Examples of
 (A) Unstable, (B) Stable, and (C) Very Stable Inversion
 Lapse Rates in a Dry Atmosphere

Table 4.2-4
Key to Stability Categories

Surface Wind Speed (at 10 m) m/sec	<u>Isolation</u>			<u>Night</u>	
	Strong	Moderate	Slight	Thinly Overcast or $\geq 4/8$ Low Cloud	$\leq 3/8$ Cloud
< 2	A	A-B	B	-	-
2-3	A-B	B	C	E	F
3-5	B	B-C	C	D	E
5-6	C	C-D	D	D	D
> 6	C	D	D	D	D

The neutral category, D, should be assumed for overcast conditions during day or night.

Stability Category A-C; Looping

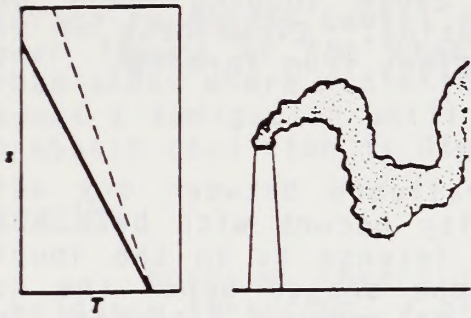

Stability Category D; Coning

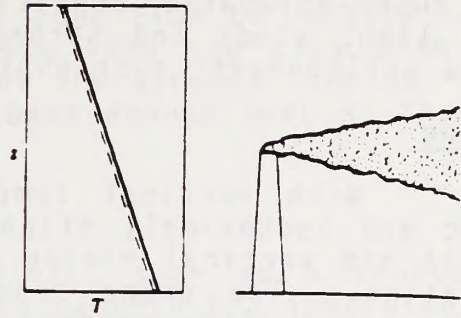

Stability Category E-G; Fanning

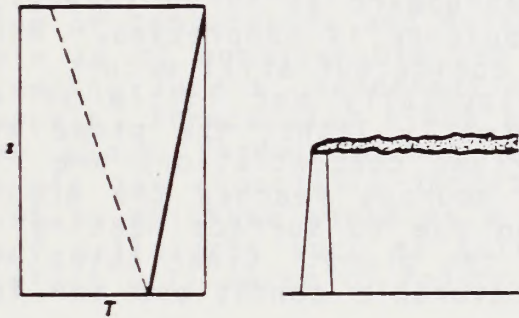

Stability Categories As Noted;
Lofting

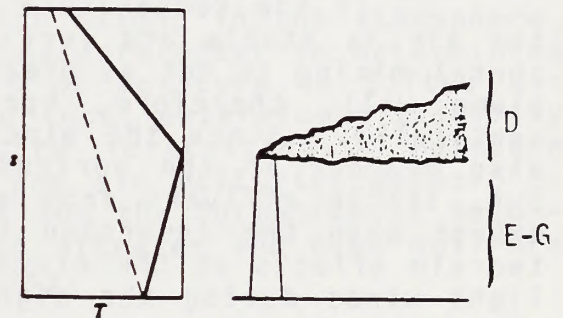

Stability Categories As Noted;
Fumigation

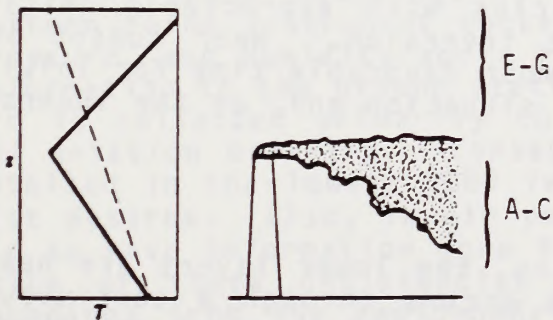

Stability Categories As Noted;
Trapping Inversion

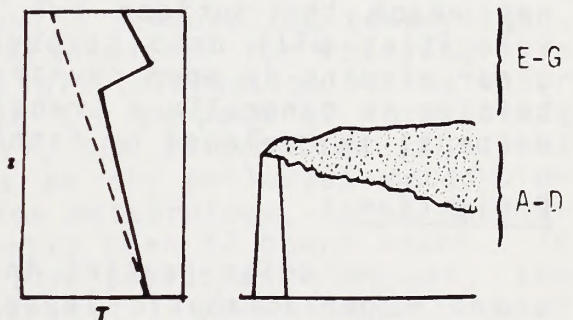

Figure 4.2-6
Typical Plume Behavior*

* Plume behavior influenced by the temperature lapse rate above and below the release height. The dashed lines in the profiles are the adiabatic lapse rates, included for reference, while the solid lines indicate the actual lapse rate. The Pasquill stability categories are also provided.

Diffusion is good, however, when considering longer time periods. The super-adiabatic conditions which cause looping occur only with light winds and strong solar heating. Cloudiness or high winds will prevent such unstable conditions from forming.

Coning

With vertical temperature gradients between dry adiabatic and isothermal, slight instability occurs with both horizontal and vertical mixing but not as intense as in the looping situation. The plume tends to be cone shaped hence the name coning. The plume reaches the ground at greater distances from the source than with the looping plume. Coning is prevalent on cloudy or windy days or nights. Diffusion equations are more successful in calculating concentrations for this type of plume than for any other.

Fanning

If the temperature increases upward as in an inversion, the air is stable and vertical turbulence is suppressed. Horizontal mixing is not as great as in coning but still occurs. The plume will, therefore, spread horizontally but little if any vertically. Since the winds are usually light, the plume will also meander in the horizontal. Plume concentrations are high but, little effluent from elevated sources reaches the ground, except when the inversion is broken due to surface heating, or terrain effects at the elevation of the plume. Clear skies with light winds during the night are favorable conditions for fanning.

Lofting

Lofting occurs when there is a super-adiabatic layer above a surface inversion. With this condition, diffusion upward is rapid, but downward, diffusion does not penetrate the inversion and so is dampened out. Under these conditions, gases will not reach the surface but particles with appreciable settling velocities will drop through the inversion. Near sunset on a clear evening in open country is most favorable time for lofting. Lofting is generally a transition situation and, as the inversion deepens, is replaced by fanning.

Fumigation

As solar heating increases, the lower layers are heated and a super-adiabatic lapse rate occurs through a continuously deeper layer. When the layer is deep enough to reach the fanning plume, thermal turbulence will bring high concentrations to the ground along the full length of the plume. This is favored by clear skies and light winds and is apt to occur more frequently in summer due to increased heating.

Another type of fumigation may occur in the early even-

ing over cities. Heat sources and mechanical turbulence due to surface roughness causes an adiabatic condition to develop in the lower layers of the stable air moving into the city from non-urban areas where radiation inversions are already forming. This causes a fumigation until the city loses enough heat so that the adiabatic condition is diminished.

Trapping

When an inversion occurs aloft, such as a frontal or subsidence inversion, a plume released beneath the inversion will be trapped beneath it. Even if the diffusion is good beneath the inversion, such as with a coning plume, the limit to upward diffusion will increase concentrations in the plume and at ground level.

4.2.4 Mixing Heights and Inversions

An adiabatic diagram can be used to plot the distribution of temperature and moisture, with height in the atmosphere. This is of considerable use to the meteorologist in determining freezing levels, condensation levels of moisture in lifted air parcels, forecasting cloud bases and tops, determining stability for cloud formation and thunderstorm forecasting. Moisture levels are especially important to the air pollution meteorologist as moisture works as a catalyst for the formation of secondary pollutants such as sulfates and nitrates and high moisture content will serve to reduce visibility.

To the air pollution meteorologist a sounding plotted on an adiabatic chart is principally used to determine the large scale stability of the atmosphere over a given location. The principal source of atmospheric measurements that may be plotted on the adiabatic chart are the radiosonde measurements taken twice daily: 0000 GMT (1900 EST) and 1200 GMT (0700 EST) at about 66 stations in the contiguous United States. The method of obtaining these soundings is to release into the atmosphere a balloon borne instrument package having sensors for temperature, pressure, and humidity and a radio transmitter for relaying this information to the ground station. This information on the upper air is collected primarily to serve the purpose of forecasting and aviation briefing. Consequently, the information is not as detailed in the lowest 5000 feet as an air pollution meteorologist desires. Also, in air pollution meteorology, it is desirable to have information more frequently than 12 hours apart. In spite of these deficiencies for air pollution purposes, the soundings from the radiosonde network will give indications of the stability of the atmosphere. On an adiabatic chart, temperature is plotted on a linear scale against pressure on a logarithmic scale. A temperature sounding may be plotted by locating each significant level reported by the temperature and pressure given for that level. The plotted points may then be connected by straight lines to give the temperature sounding.

As indicated in Section 4.2.3, the stability of a portion of the sounding may be compared with the dry adiabatic lapse rate. If the temperature decreases more rapidly than the dry adiabats through a layer, this layer is super-adiabatic and quite unstable. If the temperature decreases, but at a rate less than the dry adiabatic lapse rate, the layer is sub-adiabatic and is more stable than super-adiabatic. If the temperature increases with height, it is an inversion.

Inversions with bases at ground level are generally radiation inversions caused by the cooling of the earth's surface and the adjacent air. However, there may also be advection inversions formed by the air's passage over a relatively cold surface. These two types of surface based inversions generally cannot be distinguished by inspection of the sounding plotted on an adiabatic diagram. A surface based inversion on an afternoon sounding is more apt to be an advection inversion.

There are two general classifications of inversions with bases above the ground: frontal inversions and subsidence inversions. Both of these, however, can also be ground based.

Frontal inversions are discontinuities in the temperature profile due to the transition between cold air below and warm air aloft. Frontal inversions usually are accompanied by increases in moisture through the inversion. Subsidence inversions are caused by the sinking motion above high pressure areas and generally have rapidly decreasing humidities above the base of the inversion.

Surveys of the meteorological aspects of air pollution are often concerned with the extent of horizontal and vertical mixing. A quantity referred to as the mixing depth is quite useful when considering dilution of pollutants in the vertical. The usual method of estimating mixing depths is to consider the stability as portrayed on a temperature sounding remembering that unstable lapse rates favor vertical mixing and stable lapse rates restrict vertical motion. The mixing depth is generally the height above the ground to which a super or dry-adiabatic lapse rate is maintained as depicted in Figure 4.2-7.

4.2.5 Influence of Topography on Transport and Diffusion

In many cases, the transport and diffusion of air pollutants is complicated by terrain features. Most large urban areas are located either in river valleys or on the shores of lakes or oceans. Both of these features alter meteorological conditions.

Valley Effects

- o Channeling
Although the more extreme effects of a valley location occur when the general flow is light, valleys tend to channel the general flow along the valley axis resulting

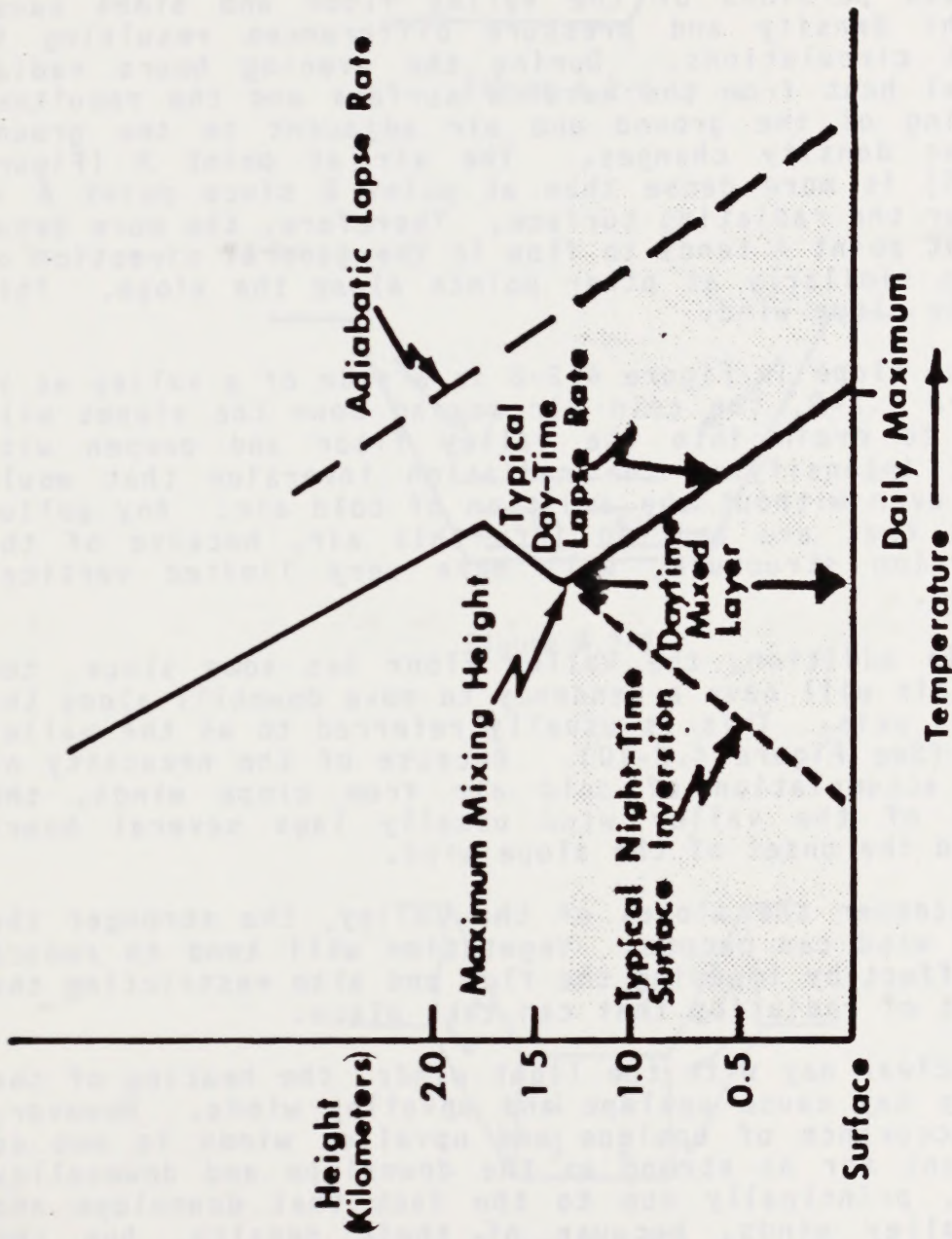

Figure 4.2-7

Calculation of Maximum Mixing Height

in a bi-directional wind frequency distribution.

o Slope and Valley Winds

When the general wind flow is light and skies are clear, the differences in rates of heating and cooling of various portions of the valley floor and sides cause slight density and pressure differences resulting in small circulations. During the evening hours radiational heat from the earth's surface and the resultant cooling of the ground and air adjacent to the ground causes density changes. The air at point A (Figure 4.2-8) is more dense than at point B since point A is nearer the radiating surface. Therefore, the more dense air at point A tends to flow in the general direction of B and similarly at other points along the slope. This is the slope wind.

If the slope in Figure 4.2-8 is a side of a valley as in Figure 4.2-9, the cold air moving down the slopes will tend to drain into the valley floor and deepen with time, intensifying the radiation inversion that would form even without the addition of cold air. Any pollutants that are emitted into this air, because of the inversion structure, will have very limited vertical motion.

If, in addition, the valley floor has some slope, the cold air will have a tendency to move downhill along the valley axis. This is usually referred to as the valley wind (See Figure 4.2-10). Because of the necessity of some accumulation of cold air from slope winds, the onset of the valley wind usually lags several hours behind the onset of the slope wind.

The steeper the slopes of the valley, the stronger the slope wind can become. Vegetation will tend to reduce the effect by impeding the flow and also restricting the amount of radiation that can take place.

On a clear day with the light winds, the heating of the valley may cause upslope and upvalley winds. However, the occurrence of upslope and upvalley winds is not as frequent nor as strong as the downslope and downvalley winds, principally due to the fact that downslope and downvalley winds, because of their density, hug the surfaces over which they travel. Flow in complex valley systems where several valleys merge at angles or slopes varies, usually require special observations to determine flow under various meteorologic conditions.

o Inversions Aloft

The trapping of air pollutants beneath inversions aloft is also a problem encountered in valleys. Two types of inversions: warm frontal and subsidence inversions are

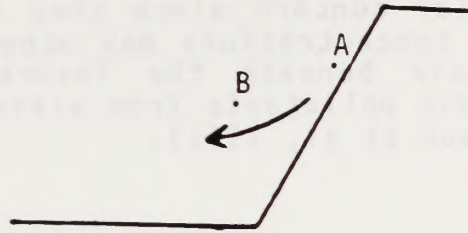

Figure 4.2-8



Figure 4.2-9

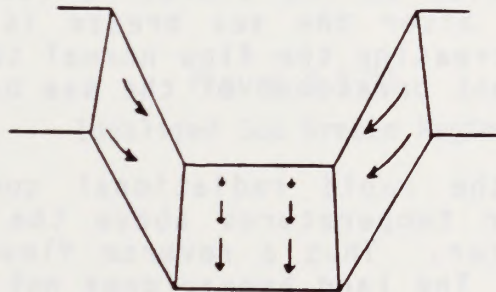

Figure 4.2-10

Valley Wind Circulations

of particular concern since they are usually slow moving. High concentrations may occur particularly if the layer of air beneath the inversion becomes unstable enough to mix pollutants from elevated sources to ground level (Hewson et al, 1961).

Shoreline Winds

The differences in heating and cooling of land and water surfaces and the air above them, result in the setting up of circulations if the general flow is light, and in the modification of thermal characteristics, and consequently, the diffusive abilities of the lower layers of the atmosphere when a general flow occurs.

o Sea or Lake Breeze

On summer days with clear skies and light winds, the heating of the land surface adjacent to a large lake or the ocean is much more rapid than the heating of the body of water. This results in a temperature difference, and consequently, a density and pressure difference between the air just above the land surface and the air over the water. Because of the pressure gradient forces, a local circulation is set up with wind from the water toward the land. There is usually some upward motion over the land and subsidence over the water accompanying the sea breeze (Estoque, 1961). There may result a weak transport from land to water aloft completing a cellular structure (See Figure 4.2-11).

In cases where a strong lake breeze occurs, air from quite some distance out over the water may be brought toward the land and, due to Coriolis forces acting over the long trajectory, the resulting flow will become nearly parallel to the shoreline (Sutton, 1953). This occurs just after the sea breeze is strongest and results in decreasing the flow normal to the coastline and the subsequent breakdown of the sea breeze.

o Land Breeze

At night, the rapid radiational cooling of the land causes lower temperatures above the land surface than over the water. Thus a reverse flow, the land breeze, may result. The land breeze does not usually achieve as high a velocity as the lake breeze, and is usually shallower than the sea or lake breeze.

Of course, any wind flow, because of the large scale pressure pattern, will alter the local circulation and the flow will be the resultant of the two effects. Usually, a light general flow is enough to overshadow the effects of land and sea breezes.

Modification of Thermal Structure by Bodies of Water

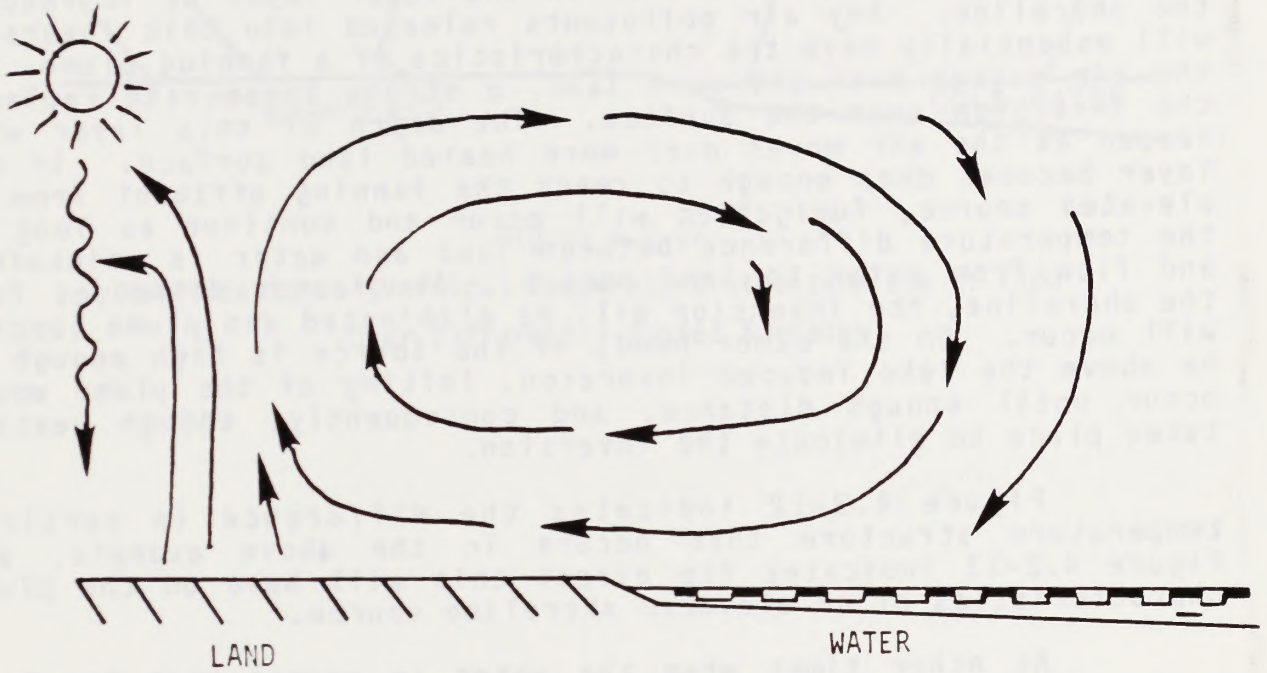

Figure 4.2-11
Idealized Sea Breeze Regime

At different seasons of the year and also different times of the day, the temperature of bodies of water and adjacent land surfaces may be quite different. For example, during the late spring, large bodies of water are still quite cold relative to adjacent land surfaces, and during mid-afternoon this difference is greatest due to the more rapid heating of the land surface. If the general flow in the area is such that the wind has a lengthy trajectory over the water and is blowing toward the shore, an interesting modification of the temperature structure takes place. Because of the passage over the cold water surface, the air will have an inversion in the lower layer as it reaches the shoreline. Any air pollutants released into this inversion will essentially have the characteristics of a fanning plume. As the air passes over the warm land, a strong lapse rate replaces the inversion near the surface. The depth of this layer will deepen as the air moves over more heated land surface. If the layer becomes deep enough to reach the fanning effluent from an elevated source, fumigation will occur and continue as long as the temperature difference between land and water is maintained and flow from water to land occurs. At greater distances from the shoreline, the inversion will be eliminated and plume looping will occur. On the other hand, if the source is high enough to be above the lake induced inversion, lofting of the plume would occur until enough distance, and consequently, enough heating takes place to eliminate the inversion.

Figure 4.2-12 indicates the difference in vertical temperature structure that occurs in the above example, and Figure 4.2-13 indicates the effect this will have on the plume characteristics of an elevated shoreline source.

At other times when the water is warmer than the land surface (late fall), offshore flow will result in fumigation over the water.

Influence of Hills

The influence of hills upon transport and diffusion depends upon a number of factors. Whether the source is on the windward or lee side of the hill or ridge is important. A smooth hill will only slightly alter the flow, while one with sharp ridges will cause turbulent eddies to form. The stability of the atmosphere will affect the overall influence of hills. During stable conditions, the air will tend to flow around obstructions. Under unstable conditions, the tendency is for air to move over obstructions.

When a source is located upwind of a hill or ridge, the pollutants may come in contact with the facing slope, particularly under stable conditions. If the ridge is quite rough, induced turbulence may cause mixing down to the slope even when the general flow is over the ridge. Wind tunnel studies or field trials with constant level balloons may be desirable to determine the flow under given circumstances.

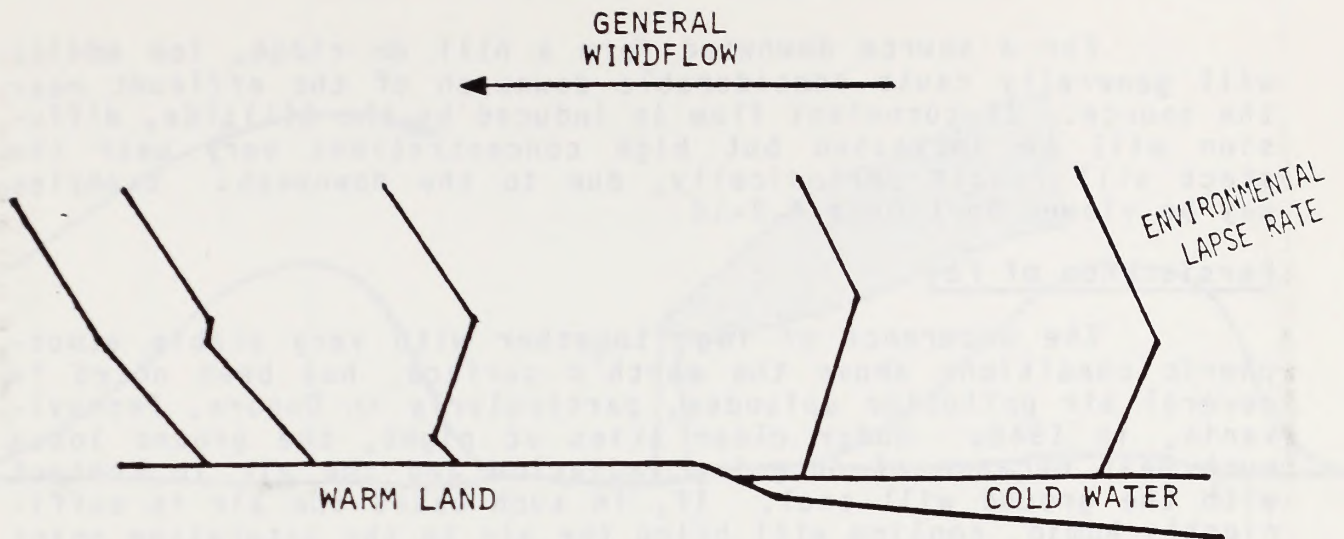

Figure 4.2-12
 Modification of Vertical Temperature Structure Due to Flow
 Over Differently Heated Surfaces

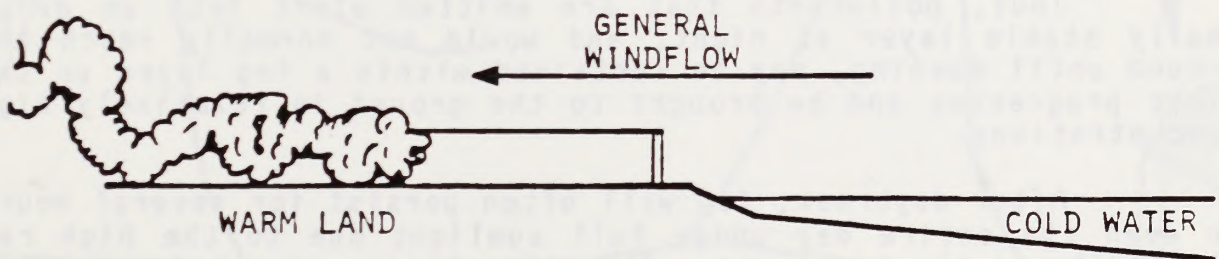

Figure 4.2-13
 Effect Upon Plume Characteristics of Flow Over Differently
 Heated Surfaces

For a source downwind from a hill or ridge, lee eddies will generally cause considerable downwash of the effluent near the source. If turbulent flow is induced by the hillside, diffusion will be increased but high concentrations very near the stack will result periodically, due to the downwash. Examples may be viewed in Figure 4.2-14

Persistence of Fog

The occurrence of fog, together with very stable atmospheric conditions above the earth's surface, has been noted in several air pollution episodes, particularly in Donora, Pennsylvania, in 1948. Under clear skies at night, the ground loses much heat because of outgoing radiation and the air in contact with the ground will cool. If, in such cases the air is sufficiently humid, cooling will bring the air to the saturation point and a fog will form. This is the mechanism which produces radiation fog and is quite common in valley locations. The top of a layer of fog will radiate essentially as a black body and cool further, thus forming an inversion layer directly above the fog. As the earth continues to radiate in the infrared, the fog droplets absorb nearly all this heat since the droplet size distribution is similar to the wavelengths of the radiation. Theory and observation have shown that when the top of a fog layer radiates during the night, the interior of the layer will become more unstable with time. Increased vertical mixing will occur from below but will be capped by the inversion. Since the air is saturated, an unstable lapse rate will exist if the temperature decrease with height is greater than the moist or pseudo-adiabatic lapse rate (3°F per 1000 ft.), rather than the dry adiabatic lapse rate of (5.4°F per 1000 ft.)

Thus, pollutants that are emitted aloft into an originally stable layer at night, and would not normally reach the ground until morning, may be contained within a fog layer as the night progresses and be brought to the ground in relatively high concentrations.

After daybreak, fog will often persist for several hours or even the entire day under full sunlight due to the high reflectivity of the top layer. The reflectivity or albedo of thick fogs averages 50% and can be as high as 85%. This delays and lessens the heating of the ground and subsequent evaporation of the fog droplets. An unstable lapse rate may occur above the fog layer, but due to a lack of surface heating, an inversion will often occur within the layer. If high concentrations of particulate pollutants are present, it may be difficult to determine just when the fog has dissipated since particulates scatter and absorb visible light very well and the visibility may remain quite restricted.

Figure 4.2-15 illustrates how fog can persist in valley situations and maintain a lid on vertical dispersion. This situation often occurs over the Central Valley of California

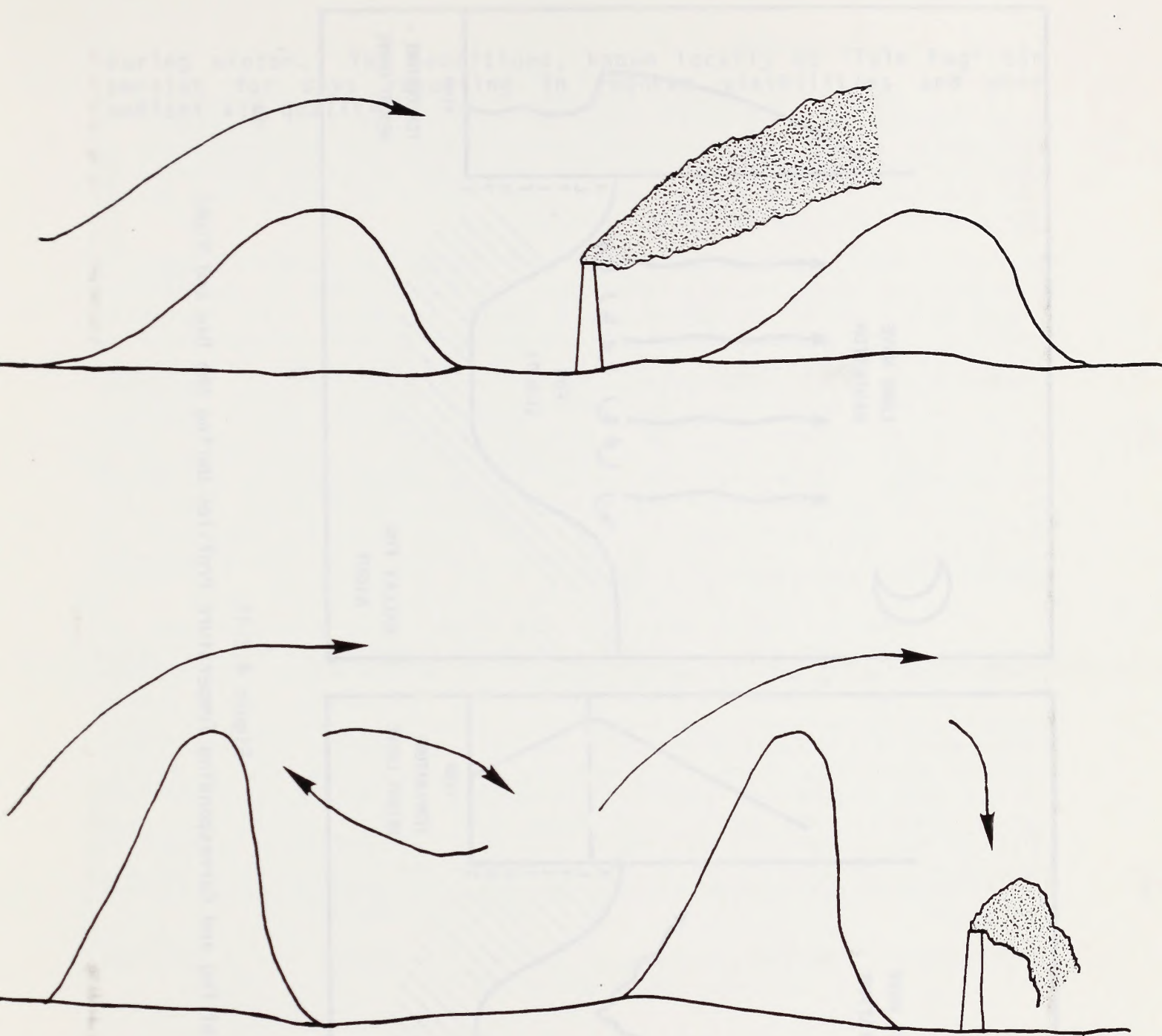

Figure 4.2-14
Influence of Hills Upon Transport and Diffusion

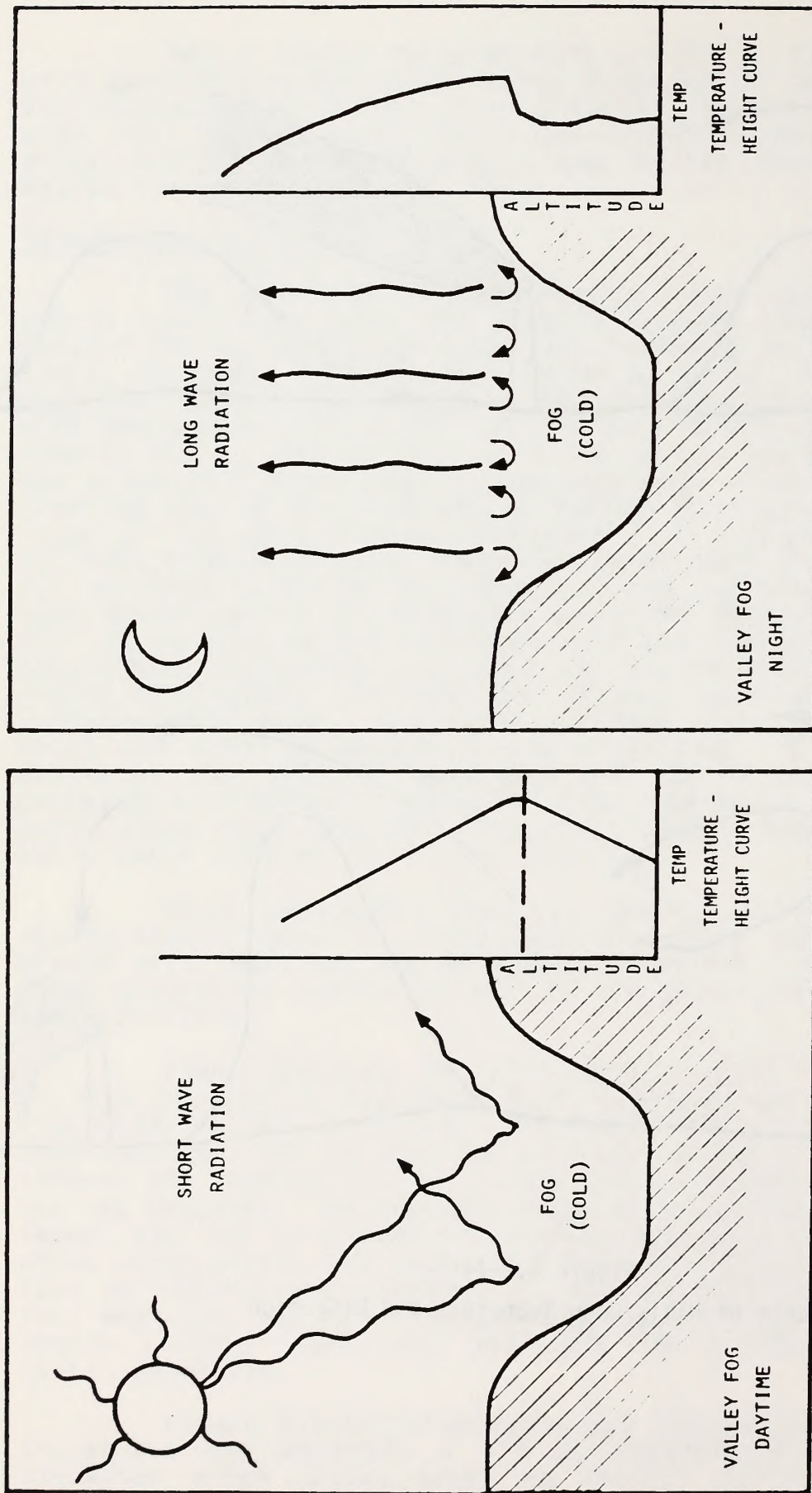

Figure 4.2-15 Persistence of Fog and Corresponding Temperature Profiles During the Day and Night

during winter. The conditions, known locally as "Tule Fog" can persist for days resulting in reduced visibilities and poor ambient air quality.

The Tule-Fog is a local phenomenon that occurs in the Sacramento-San Joaquin River Delta and is characterized by reduced or no visibility, reduced temperatures and high humidity. The greatest visibility is observed in the morning and the least in the afternoon. It is a result of the inversion of the atmosphere and the presence of fog droplets.

The following section describes the Tule-Fog phenomenon and its impact on the Delta. The Tule-Fog is a local phenomenon that occurs in the Sacramento-San Joaquin River Delta and is characterized by reduced or no visibility, reduced temperatures and high humidity. The greatest visibility is observed in the morning and the least in the afternoon. It is a result of the inversion of the atmosphere and the presence of fog droplets.

The following section describes the Tule-Fog phenomenon and its impact on the Delta. The Tule-Fog is a local phenomenon that occurs in the Sacramento-San Joaquin River Delta and is characterized by reduced or no visibility, reduced temperatures and high humidity. The greatest visibility is observed in the morning and the least in the afternoon. It is a result of the inversion of the atmosphere and the presence of fog droplets.

10/1/01 - 10/1/01
10/1/01 - 10/1/01

4.3 DATA SOURCES

Sources of dispersion meteorological data are limited in the Susanville District. Many of these data are available in unreduced or partially reduced form and have not been utilized in the present analysis. However, a knowledge of their availability is desirable in instances where they may be of value for future more detailed site-specific analyses.

For the present, the data base has been limited to sources of data readily available, reduced, and in summarized form which cover a period of 5 years or more. As discussed earlier, key parameters of interest include wind speed and wind direction, atmospheric stability, mixing heights, temperature inversions, and winds aloft. Primary sources of such complete data include first order National Weather Service (NWS) stations and special interest (usually private industry) stations. Table 4.3-1 lists the sources of key meteorological stations located in or near the Susanville District which have been used to establish a regional assessment of dispersion meteorology. Other reference materials and data sources are also discussed in the text in instances where they add additional insight into the dispersion meteorology for specific areas.

The following sections are based upon two key sets of data. These include (1) STability ARray (STAR) data as available from the National Climatic Center (NCC) in Asheville, North Carolina and (2) NWS and California Air Resources Board (CARB) upper air temperature and wind data. STAR data provide the joint frequency distribution of wind speed, wind direction and atmospheric stability class on a monthly, seasonal and annual basis. Within the Susanville District, STAR data are not available. For this reason, available data from Red Bluff, California, and Fallon and Lovelock, Nevada, are used in the more exhaustive analyses. These data were chosen to provide a representative and cost-effective cross-section of the dispersion meteorology of the District.

Table 4.3-1
 Available Dispersion Meteorological Data
 in and near the Susanville District

Station Name	County Location	Data Description	Period of Data Base
Red Bluff	Tehama	Wind speed, wind direction and atmospheric stability (8 obs./day)	1/72 - 12/76
Fallon	Churchill, Nevada	Wind speed, wind direction and atmospheric stability (24 obs./day)	1/66 - 12/70
Lovelock	Pershing, Nevada	Wind speed, wind direction and atmospheric stability (8 obs./day)	1/66 - 12/70
Sacramento	Sacramento	Vertical temperature soundings and mixing height summaries	9/71 - 2/74
Lake Almanor	Plumas	Vertical temperature soundings	11/71 - 4/72
Alturas	Modoc	Vertical temperature soundings	5/72 - 6/72
Montague	Siskiyou	Vertical temperature soundings	12/73 - 2/74
Medford	Jackson, Oregon	Vertical temperature soundings	2/72 - 6/74
Red Bluff	Tehama	Vertical temperature soundings and mixing height summaries	10/71 - 2/74

4.4 PREVAILING WINDS

The characterization of prevailing surface winds and winds aloft is essential in the development of an understanding of the dispersion meteorology of the Susanville District. This section provides analyses that are designed to identify specific characteristics of the prevailing winds. These analyses include:

- o Wind Roses
- o Diurnal Wind Distributions
- o Wind Speed Distributions
- o Wind Persistence Analyses
- o Trajectory Analyses
- o Winds Aloft

The prevailing winds define the net regional transport characteristics for pollutants in a given geographical area. An understanding of the physical behavior of air flow in and out of a particular area of interest provides insight as to the fate of air pollutants.

4.4.1 Wind Roses

Wind roses provide a graphical representation of the frequency of occurrence of winds from each of the 16 cardinal directions for specified averaging periods. This subsection discusses the prevailing winds using wind rose analyses on a seasonal and annual basis.

Regional wind characteristics throughout the Susanville District are discussed in considerable detail in Section 3.4. This includes a summary of monthly and annual average wind speeds and prevailing wind directions throughout the study area. Also, a Susanville District study map with numerous superimposed annual wind roses was provided in order to depict the air flow on a regional scale. The discussion provided in this section is designed to summarize prevailing air flow characteristics in terms of a dispersion analyses for subsequent use in pollutant impact studies.

Annual

Annual wind rose diagrams for selected key stations near the District are provided in Figures 4.4-1 through 4.4-4. Red Bluff and Sacramento wind roses describe wind conditions characteristic of the Sacramento Valley which lies to the south and west of the Susanville District. Fallon and Lovelock represent typical inland stations east of the major mountain range traversing California longitudinally. For this reason, these latter stations are indicative of conditions experienced in much of the Susanville District. Figure 4.4-5 provides a study map of the District, superimposed with annual wind rose diagrams. This figure appeared in Section 3.4 but is presented here, as well, due to its importance in describing regional flow characteristics.

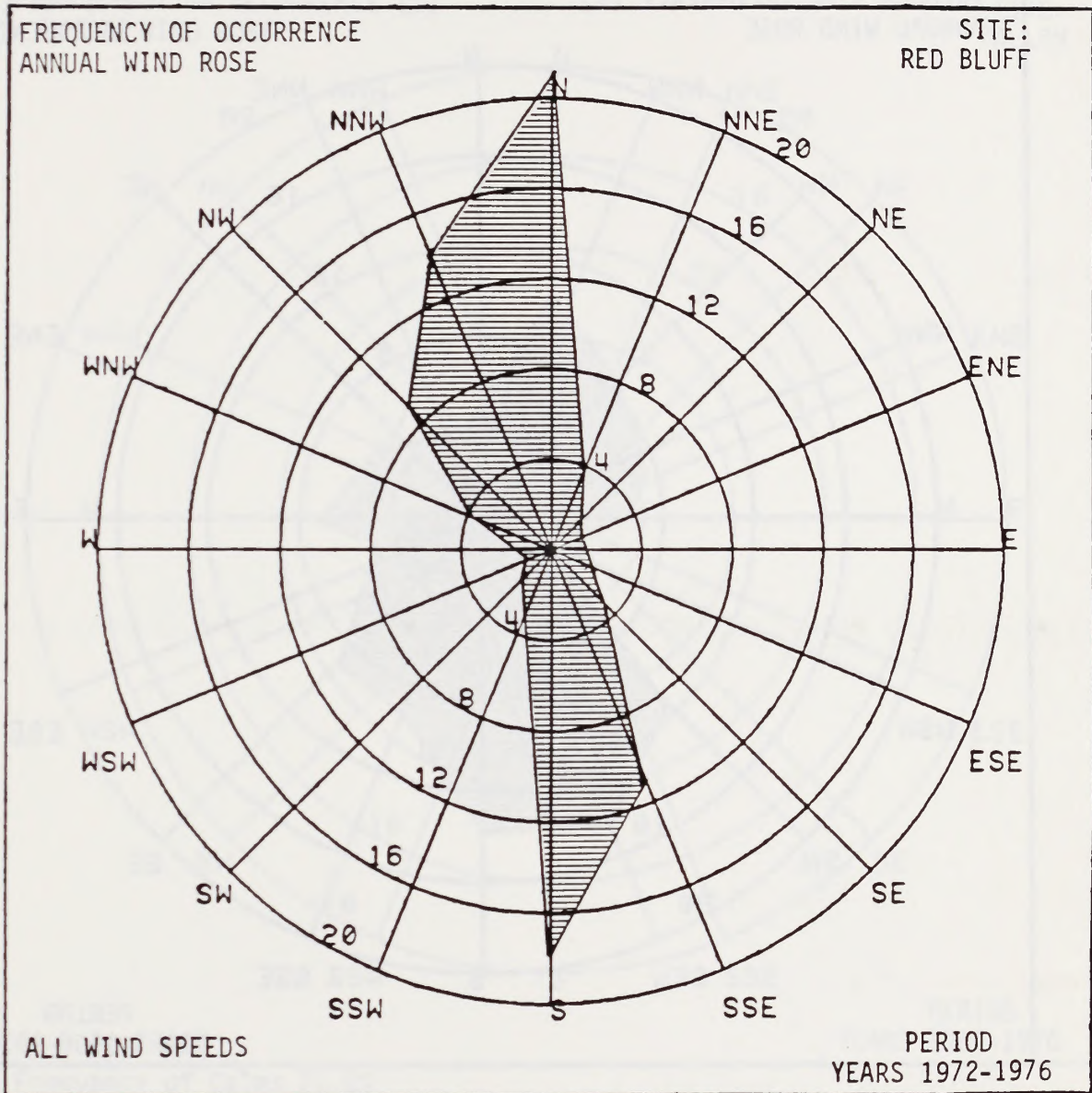

Figure 4.4-1
Annual Wind Rose for Red Bluff
(1972 - 1976)

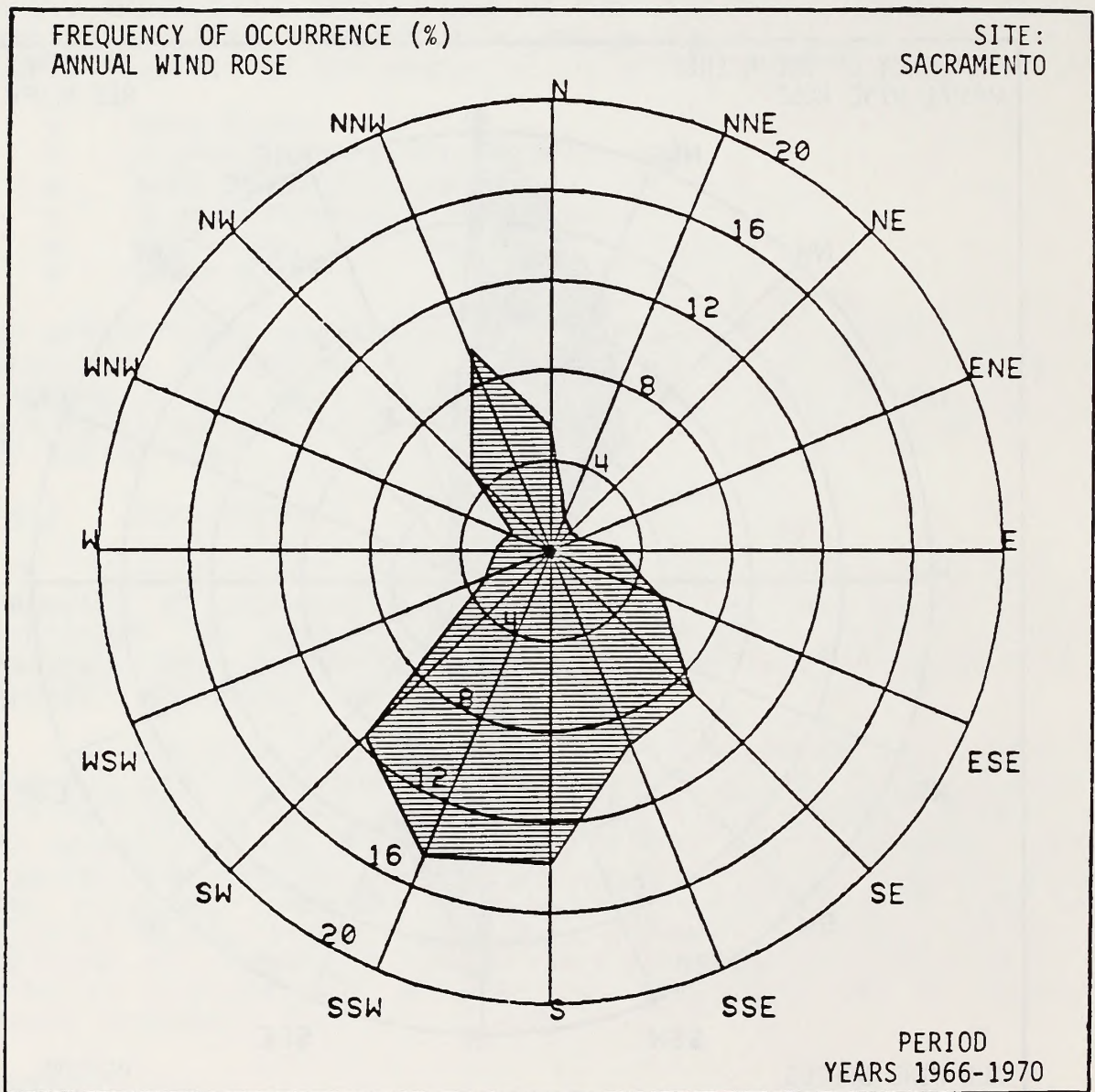
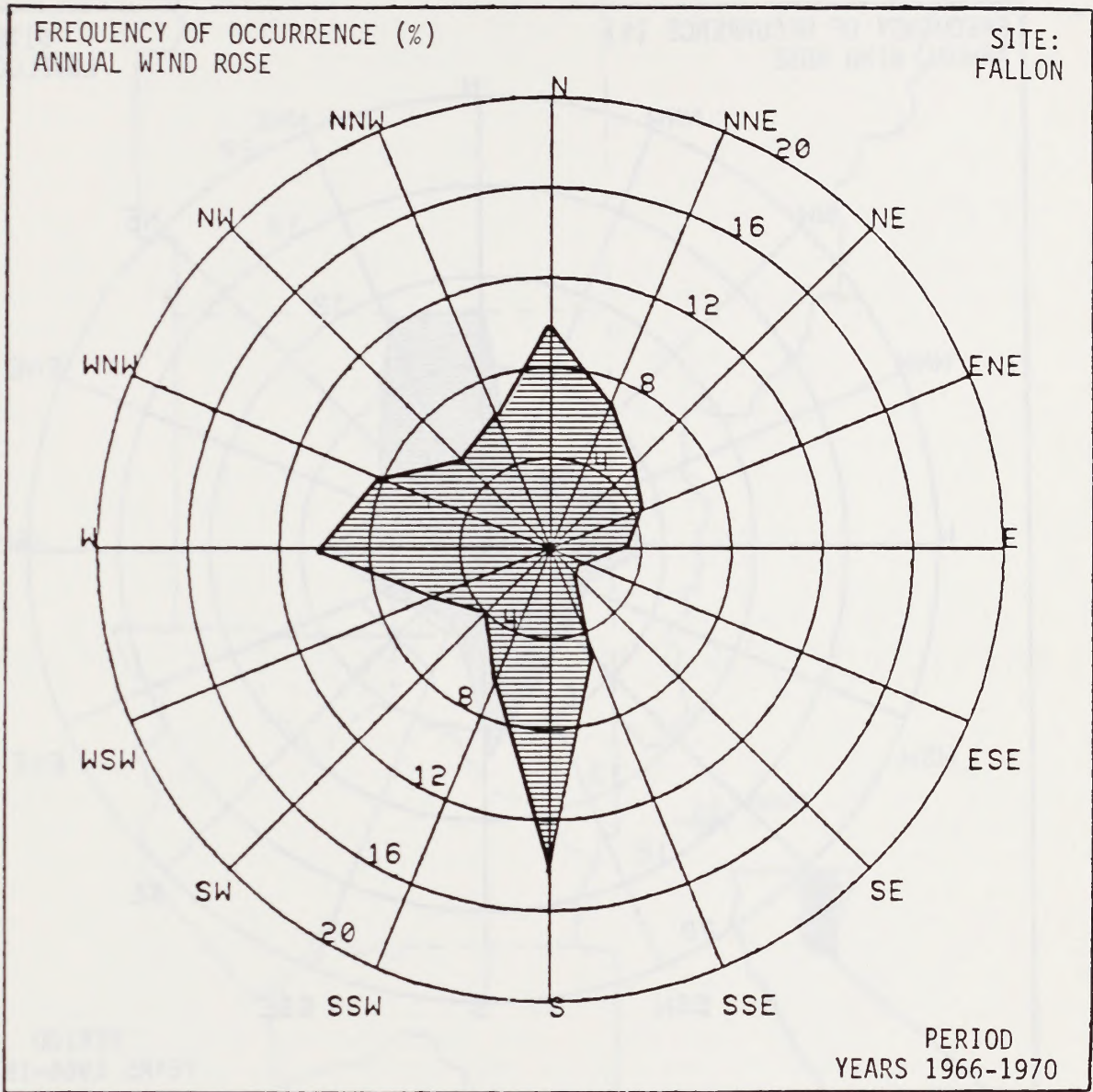
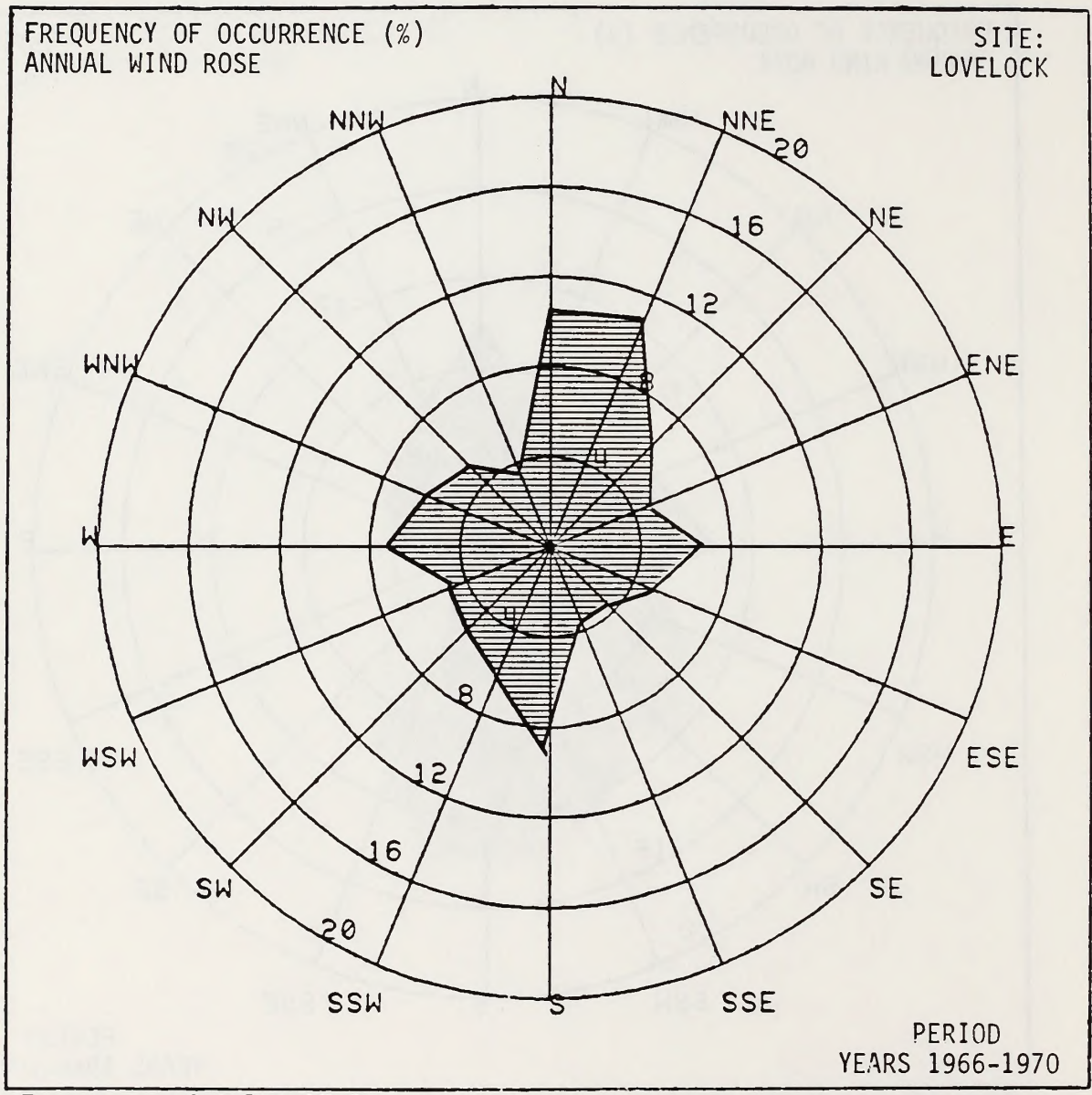

Figure 4.4-2
Annual Wind Rose for Sacramento
(1966-1970)



Frequency of Calms 21.0%

Figure 4.4-3
Annual Wind Rose for Fallon
(1966 - 1970)



Frequency of Calms 37.2%

Figure 4.4-4
Annual Wind Rose for Lovelock
(1966 - 1970)



Figure 4.4-5
Annual Wind Rose for Selected Key Stations
in the Susanville District

Source: Department of Water Resources, "Wind in California", 1978
Note: Each Division on the Roses is Equal to an Annual Frequency of 5%



Figure 1. Map of the United States showing the location of the study area (shaded area) in the western part of the country. The map is based on the 1992 Census of the United States. The shaded area is located in the western part of the United States, specifically in the state of California. The map shows the state boundaries and the location of the study area. The map is based on the 1992 Census of the United States. The shaded area is located in the western part of the United States, specifically in the state of California.

The annual wind roses for Sacramento and Red Bluff are presented in Figures 4.4-1 and 4.4.-2 and are indicative of prevailing flow over the Central Valley portion of California. As indicated in previous sections, detailed data on prevailing winds are not available for stations located in the Susanville District and for this reason data available from Sacramento and Red Bluff have been presented to provide an indication of flow in areas bordering the Susanville District to the west and south. The wind roses indicate the preponderance of flow along the axis of the Sacramento Valley at these two stations. Sacramento located northeast of the major break in the Coast Range in California, the Carquinez Straits, experiences a heavy preponderance of flow from the south and southwest. This is indicative of maritime air coming into the center of California through the Carquinez Straits and being diverted to the north into the Sacramento Valley. Further to the north at Red Bluff, a strong bimodal distribution is observed for winds from the north and south. Here the influence of both up and down valley flow is strongly evident. The decrease in the frequency of southerly flow at this location in comparison with the Sacramento wind rose reflects the distance of this station from the major break in the Coast Range and the concomitant decrease in the influence of maritime air. The flow from the north at Red Bluff is indicative of prevailing north and northwesterly flow over much of the northern half of California in response to synoptic or large scale pressure patterns. In the absence of local influences such as valley winds, flow from the northwest quadrant is evident at major stations throughout this portion of the state.

Figures 4.4-3 and 4.4-4 provide the annual wind roses for Fallon and Lovelock, Nevada, located to the southeast of the Susanville District. These data are indicative of stations located east of the major mountain ranges located in California and are indicative of conditions in the plateau portions of the Susanville District which comprise the bulk of the land area in this region. The data show a trimodal distribution at each station with southerly flow occurring most frequently at Fallon and a secondary maxima for winds from the west and north. At Lovelock, flow from the north constitutes the primary maximum, with a secondary maxima from the south and west. The diverse nature of these roses shows the multitude of influences experienced in this portion of the country. Flow reaches these stations either directly over elevated terrain to the east or paralleling to the terrain from the north and south. As one progresses eastward away from the higher mountain ranges, flow from the west becomes a secondary maxima, as in the absence of local channeling effects, flow tends to parallel major ranges lying to the west.

The wind roses presented in Figures 4.4-1 through 4.4-4 can be compared on a regional basis with other data not available in STAR form in Figure 4.4-5. These data provide the prevailing flow at Susanville located within the Susanville District. These data show a clear preponderance of flow from the south and south-

west and most strongly resemble the wind rose presented in Figure 4.4-3 for Fallon, Nevada. These data indicate that flow is channeling into the Susanville District through the high passes in the Sierra and Cascade Ranges which comprise the western border of the District. As indicated earlier, stations on the leeward side of major mountain ranges tend to experience the channeling effect of winds moving through this terrain and into the region.

Seasonal

Seasonal wind roses for Sacramento, Red Bluff, Fallon and Lovelock are provided in Figures 4.4-6 through 4.4-9. Figure 4.4-6 indicates the seasonal distribution at Sacramento which lies to the southwest of the Susanville District. During spring, summer and fall, southwest and south-southwesterly flow dominate at Sacramento while southeasterly winds are prevalent during the winter months. A secondary maximum occurs for north-northwesterly flow during all seasons. These drainage winds are most often observed during the winter season. The data available for Sacramento shows the preponderance of upvalley and seabreeze flow during warm season months with the prevailing northwesterly flow dominating during the cooler season. Northwesterly flow occurs during all seasons of the year but is least frequent during the summer season.

At Red Bluff, Figure 4.4-7 indicates that each seasonal rose shows a strong bimodal distribution of wind direction. During the fall, winter and spring, there is a clear preference for north through north-northwesterly flow, the prevailing flow throughout the Central Valley of California. In these seasons the secondary flow is from the south through south-southeast. These southerly winds, the result of maritime air moving northward through the Sacramento Valley, also dominate the distribution in the summer.

East of the major mountain ranges in California, data are available once again for Fallon and Lovelock, Nevada. Figure 4.4-8 provides seasonal wind roses for Fallon. The data indicate a strong seasonal difference at this station with southerly flow clearly dominating during the winter and fall months with northwesterly flow being much more prevalent during spring and summer. The southerly flow during the cooler season months at Fallon is indicative of prefrontal flow conditions as well as drainage winds at this station. The northwesterly flow during the summer season months is indicative of regional trends observed during the seasons in response to flow around the semi-permanent eastern Pacific high pressure system. This seasonal preference at Fallon should be indicative of conditions observed throughout much of the eastern portion of the Susanville District. However, once again in the absence of data specifically for stations within the Susanville District, the reader is cautioned in the use of these data.

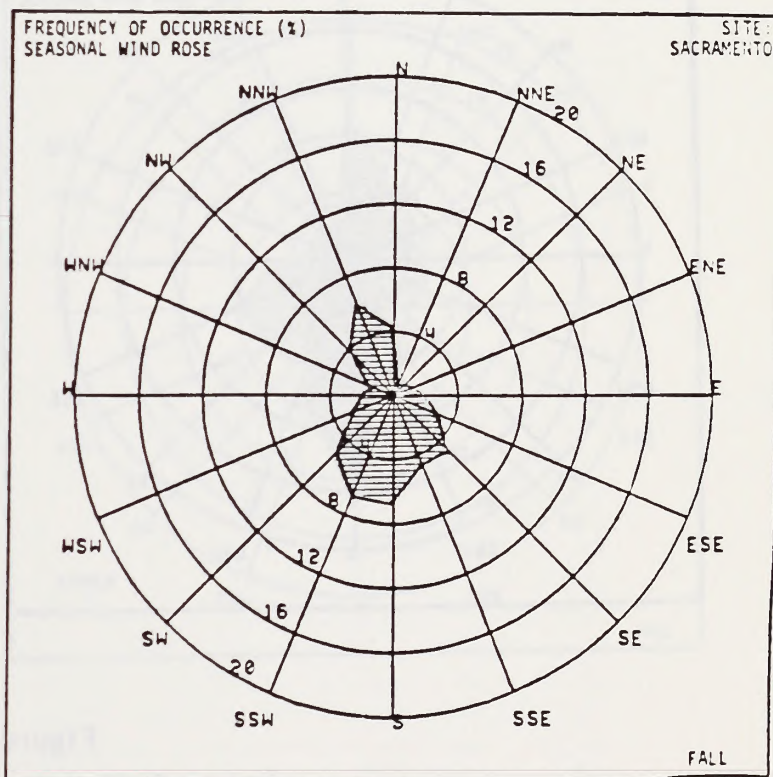
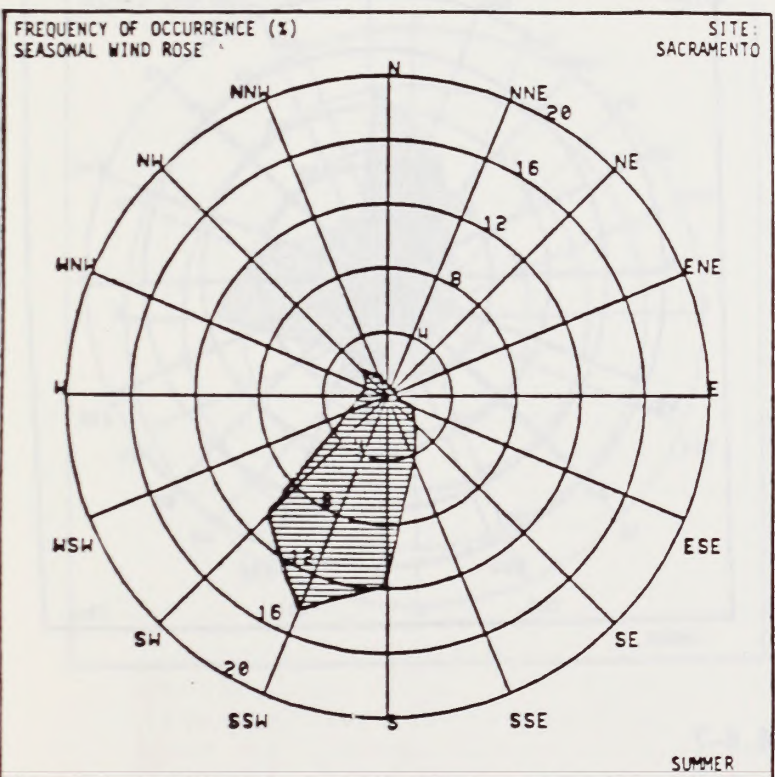
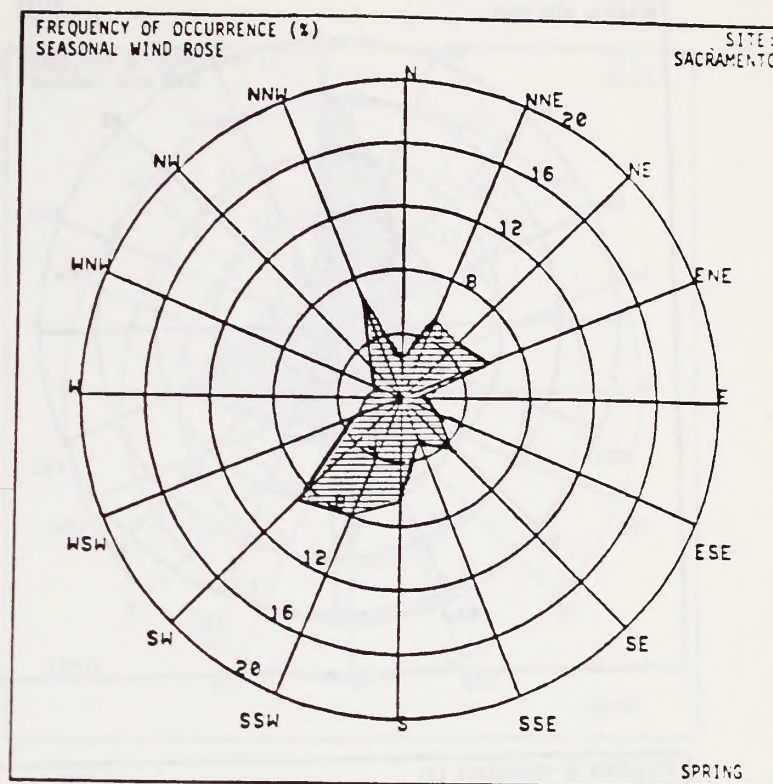
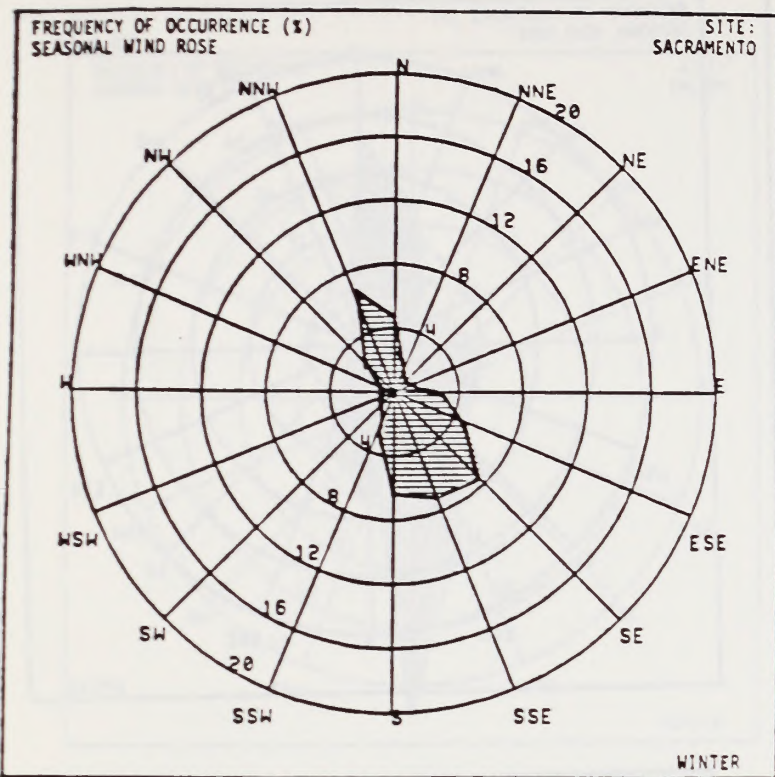

Figure 4.4-6
Seasonal Wind Roses for Sacramento

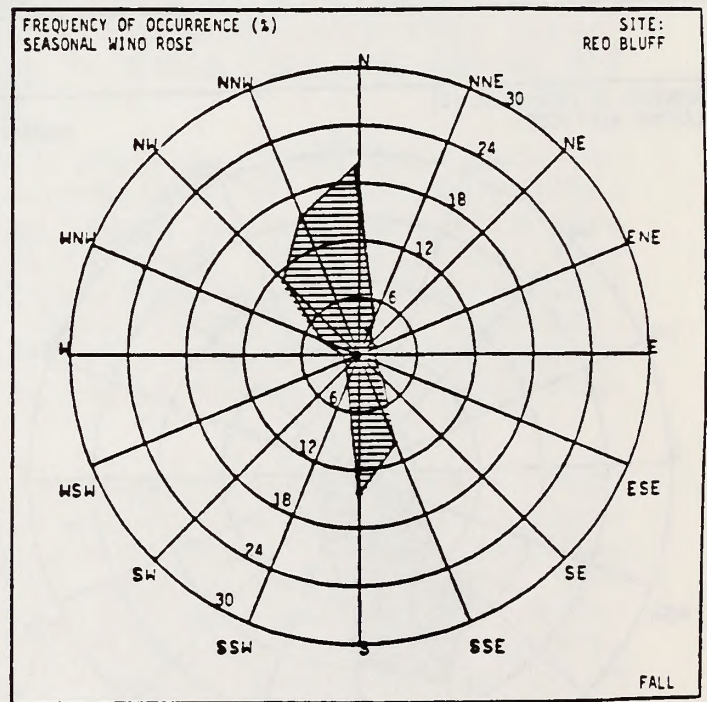
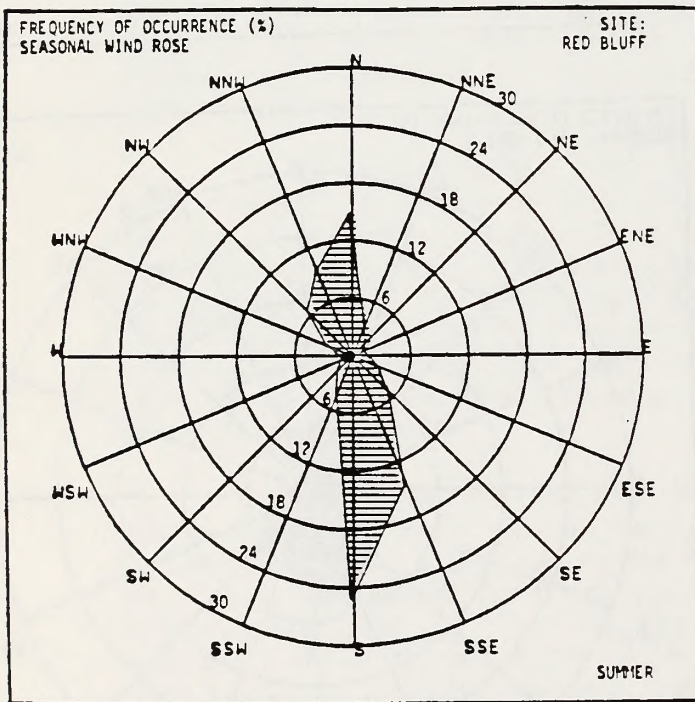
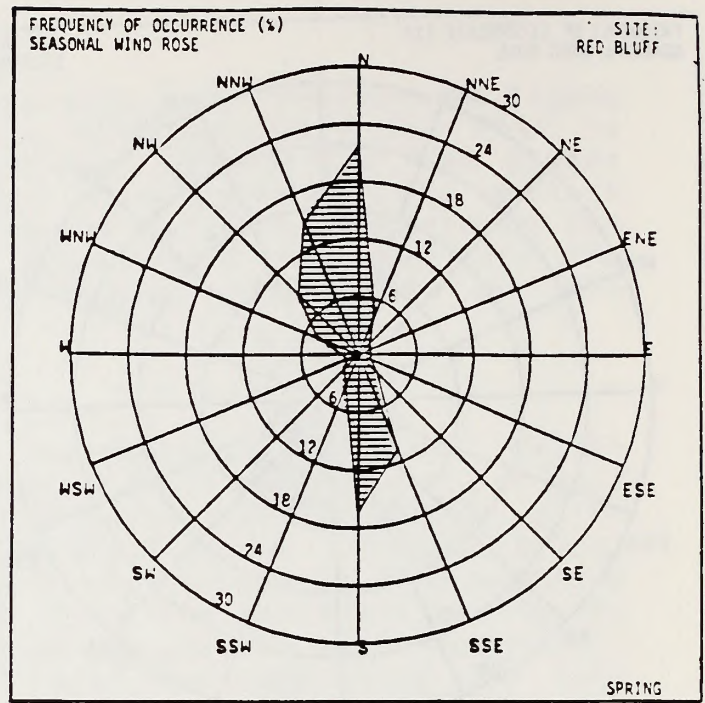
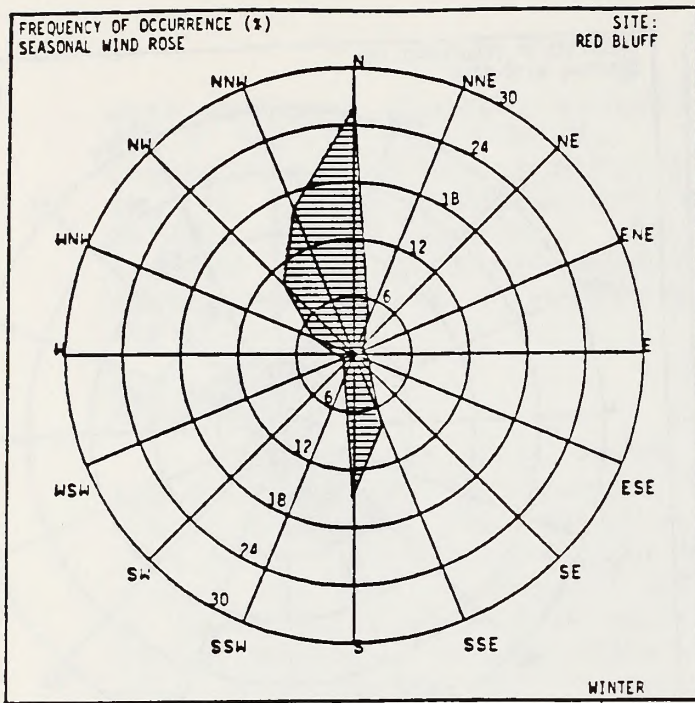

Figure 4.4-7
Seasonal Wind Roses for Red Bluff

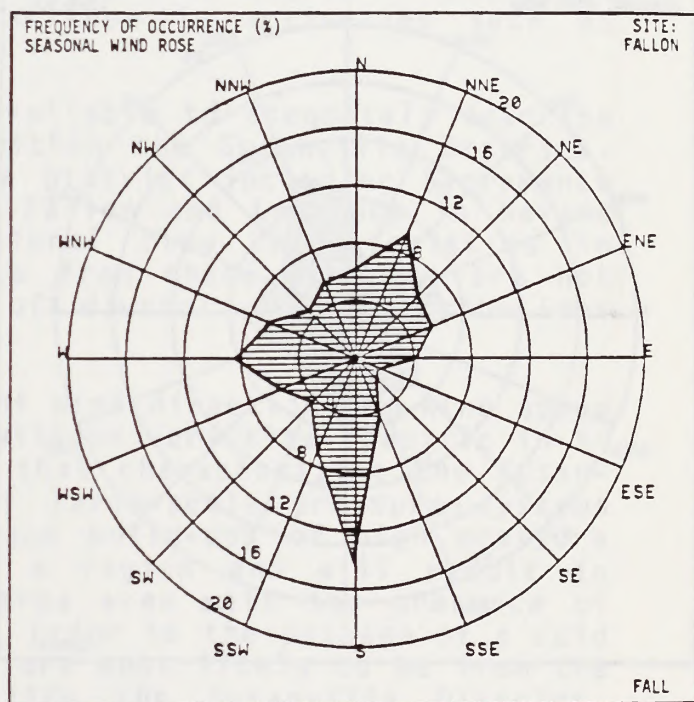
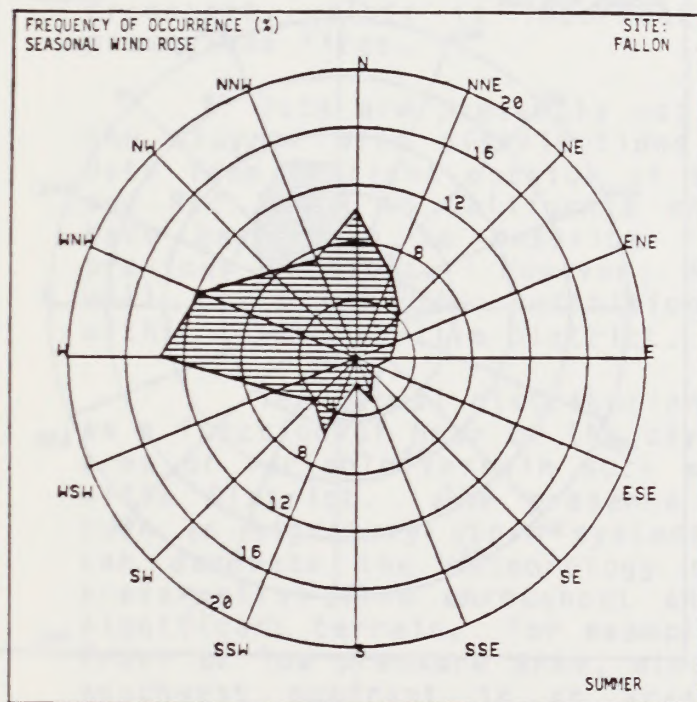
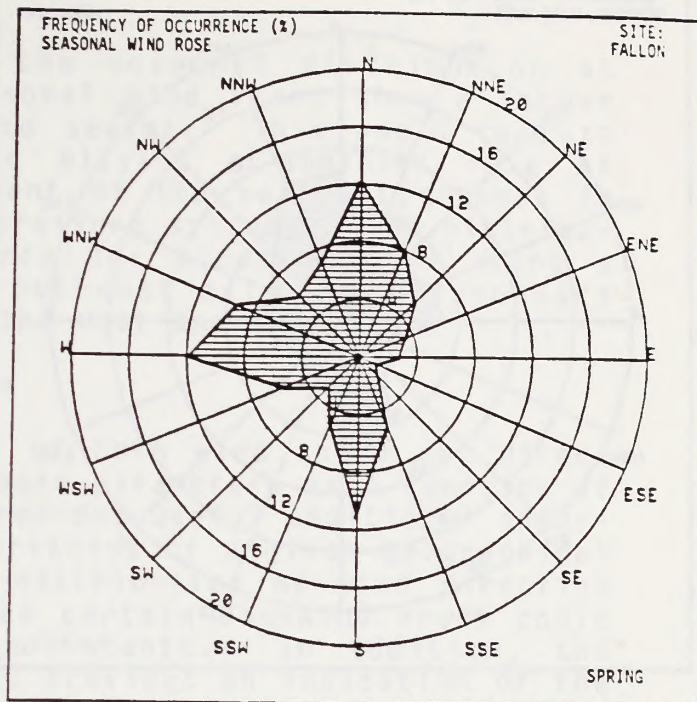
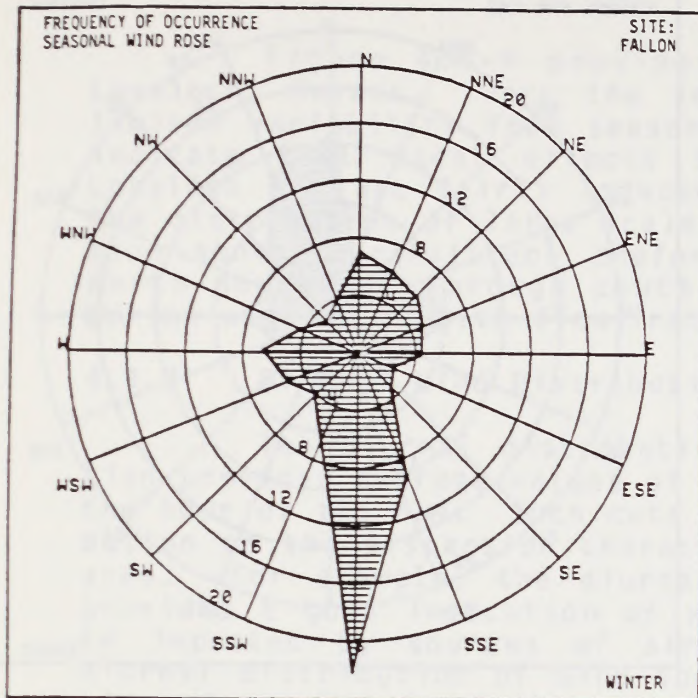

Figure 4.4-8
Seasonal Wind Roses for Fallon

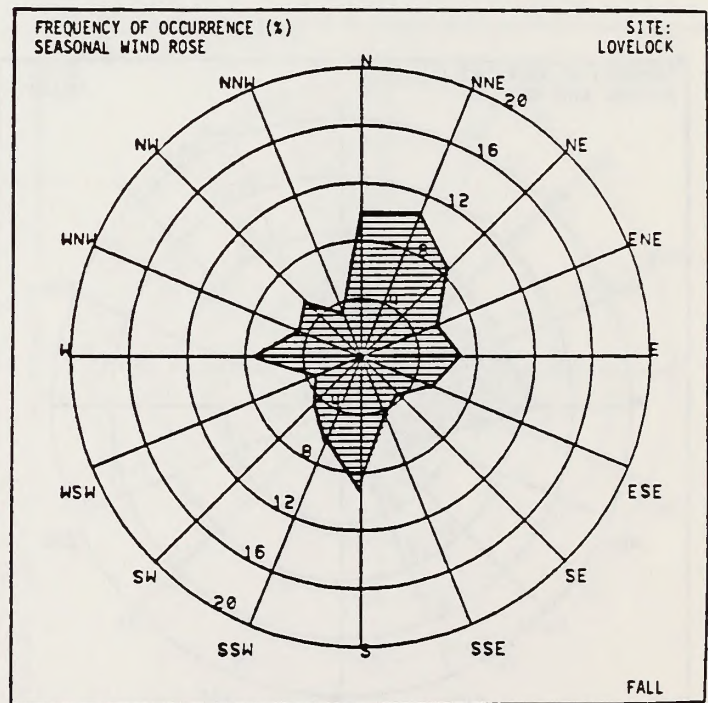
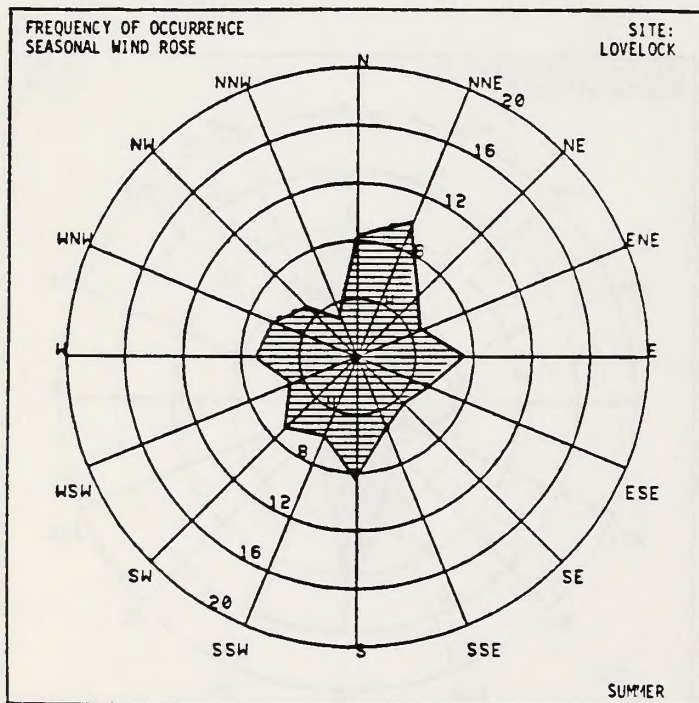
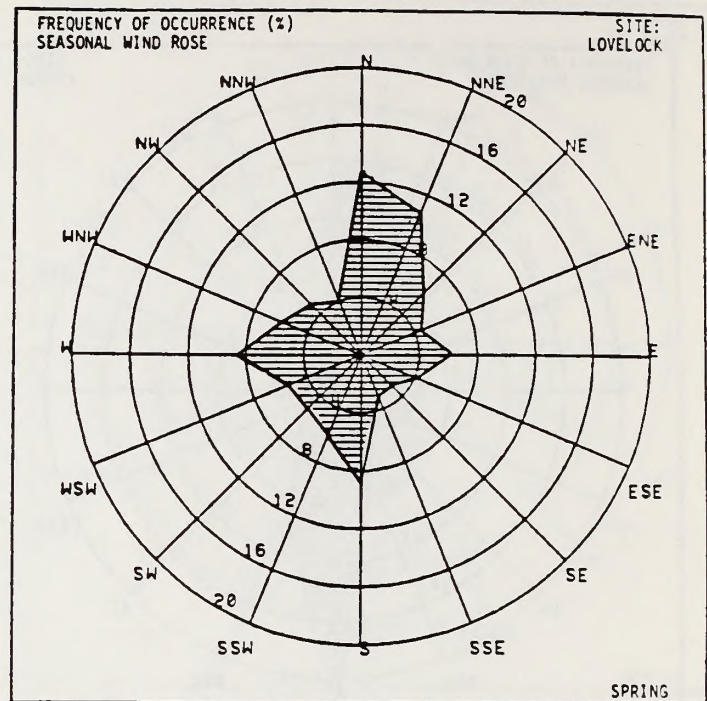
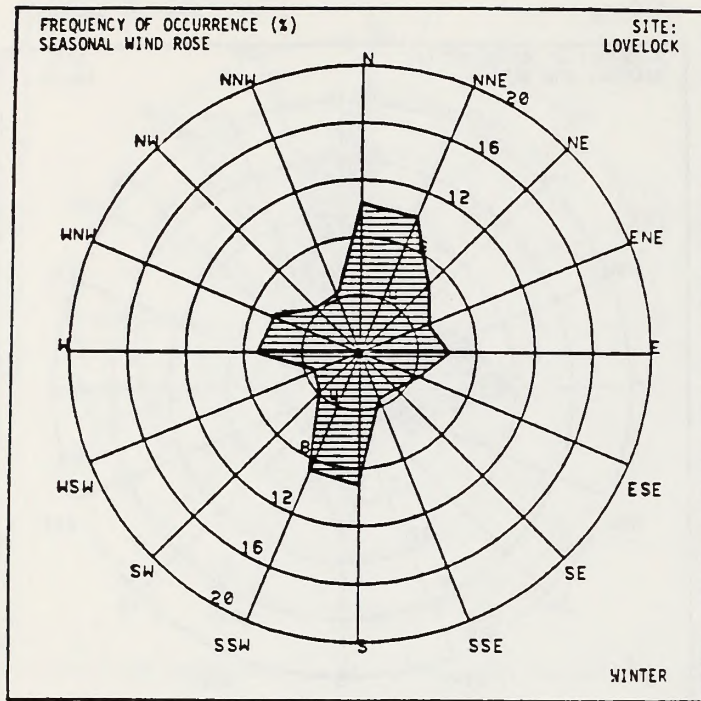

Figure 4.4-9
Seasonal Wind Roses for Lovelock

Figure 4.4-9 provides the seasonal distribution at Lovelock, Nevada. Here the seasonal wind roses show a rather limited variability from season to season. This would tend to indicate that local effects are playing a dominant role at Lovelock and are fairly independent of the seasonal changes in the distribution of large scale pressure systems. The distribution shows a consistent preference for winds aligned along a north-northeast through south-southwest axis, with secondary maxima associated with flow from the west and east.

4.4.2 Diurnal Wind Distribution

The diurnal distribution of both wind speed and direction provides average values of these parameters as a function of the hour of the day. Such data provides useful additional information on the dispersion characteristics of a given geographical area. For example, the diurnal distribution of wind direction provides a good indication of when certain downwind areas could be impacted by sources of air pollutants. In addition, the diurnal distribution of wind speed provides an indication of the time of day when best dispersion conditions can be expected based upon average wind speeds and the associated degree of pollutant transport. This is important to know in activities such as prescribed fires.

Data are presently not available to adequately describe the diurnal wind distributions within the Susanville District. Data from stations outside of the District including Sacramento and Red Bluff in California and Fallon and Lovelock in Nevada have been used to describe regional flow characteristics in previous sections. However, data from these stations are not well suited to the definition of diurnal wind distributions within the Susanville District.

The actual distribution of wind direction and wind speed as a function of hour of the day will be very site-specific in an area of variable terrain such as that characterizing the Susanville District. The presence of large-scale pressure systems such as migratory storm systems and build-ups of high pressure can dominate the meteorology of a region and will result in preferential flow throughout an area even with the presence of significant terrain. For example, prior to the passage of a cold front or low pressure area, winds are most likely to be from the southwest quadrant in an area like the Susanville District. Conversely, with the passage of these systems prevailing flow from the northwest quadrant would once again begin to dominate. Even in the presence of such formidable pressure systems local terrain effects, however, will play a role and will influence the actual preferred channeling of winds in a given area.

During a fairly significant portion of the time the diurnal distribution of wind direction and wind speed will be strongly influenced by local meteorological effects and the influence of terrain. For example, heterogenous heating effects

on the surface of the earth generally result in downslope drainage flow at night and upslope surface-induced heating flow during the day. For this reason, the preferred wind direction in a given area can be deduced largely on the basis of terrain. Wind speeds tend to be generally lightest during the night reaching their maximum during the afternoon hours when surface heating effects result in coupling with higher levels of the atmosphere where wind speeds are stronger. These effects tend to be relatively site-specific but are fairly predictable on a day-to-day basis and can be used as a guide in defining diurnal wind speed and wind direction distributions in a given area.

Figure 4.4-10 and 4.4-11 present diurnal wind direction and wind speed information from Red Bluff, California located in the Sacramento Valley southwest of the Susanville District. Once again, these data are not felt to be indicative of actual conditions observed in the Susanville District but do provide an example of diurnal trends at a regional site. The data indicate a dominance of northerly flow during the nighttime and early morning hours at Red Bluff, shifting to southerly or upvalley flow during the afternoon. The northerly flow is indicative of both drainage winds from higher terrain to the north as well as the prevailing down coastal flow prevalent in this portion of California. The transition to southerly flow results from a combination of upvalley flow as well as the influence of the seabreeze which reaches this region on many summer afternoons. The available data on wind speeds indicate that the strongest flows are associated with the development of southerly winds during the afternoon indicative of upvalley and seabreeze regime conditions. Wind speeds become fairly strong during the afternoon in the Sacramento Valley, particularly during the summer season. These data reflect the trends described in the preceding paragraphs relative to diurnal wind speeds and wind directions. Once again, actual diurnal trends in the Susanville District will be dependent upon local terrain and meteorological effects.

4.4.3 Wind Speed Distribution

The distribution of wind speed as a function of the frequency of occurrence of designated wind speed categories is routinely available for first order stations near the Susanville District. Figures 4.4-12 through 4.4-15 provide seasonal and annual distributions of wind speed as a function of six distinct categories including; (1) 0-3 knots (0-3.5 mph), (2) 4-6 knots (4.6 - 6.9 mph), (3) 7-10 knots (8.1-11.5 mph), (4) 11-16 knots (12.7 - 18.4 mph), (5) 17-21 knots (19.6 - 24.2 mph) and (6) greater than 21 knots (24.2 mph). The frequency of calms is also provided in each figure as well as conversion factors to facilitate the use of both English and metric units.

The figures indicate an interesting difference between the California stations located to the southwest of the Susanville District and the Nevada stations felt to be indicative of conditions over the bulk of the Susanville District. Figure 4.4-

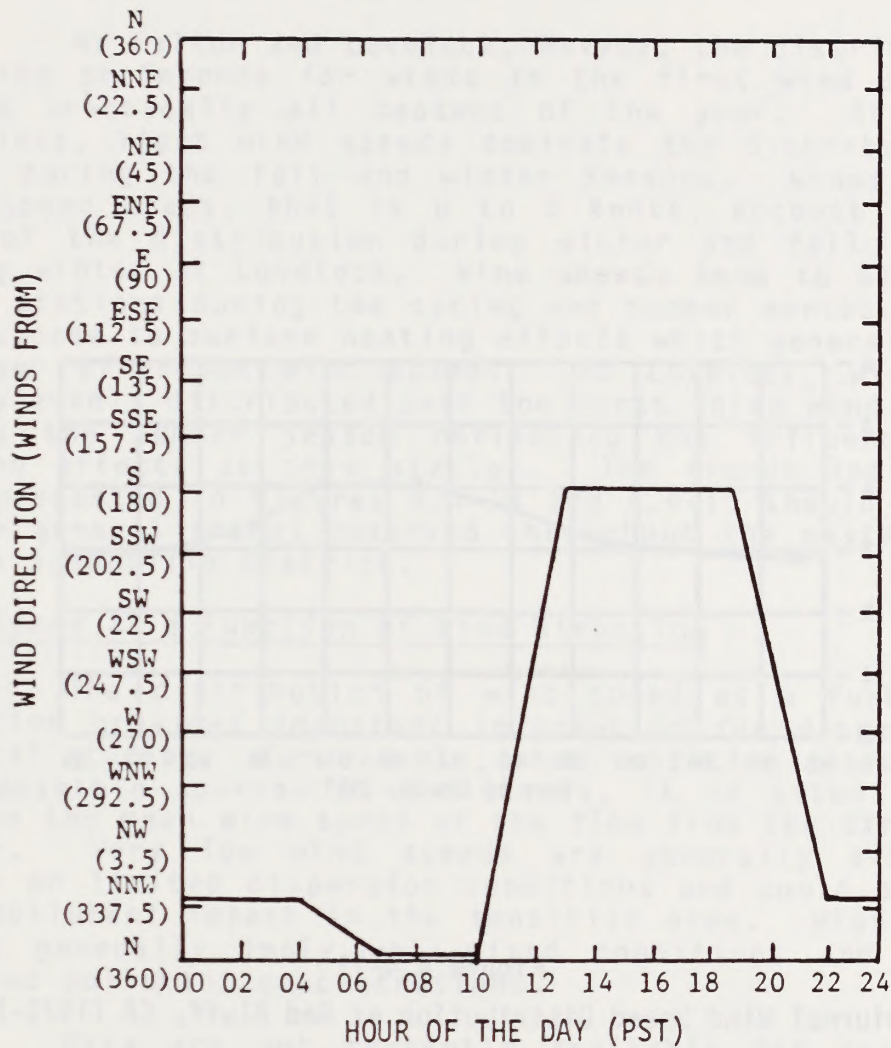

Figure 4.4-10
 Diurnal Wind Direction Distribution
 at Red Bluff, CA (1972-1976)

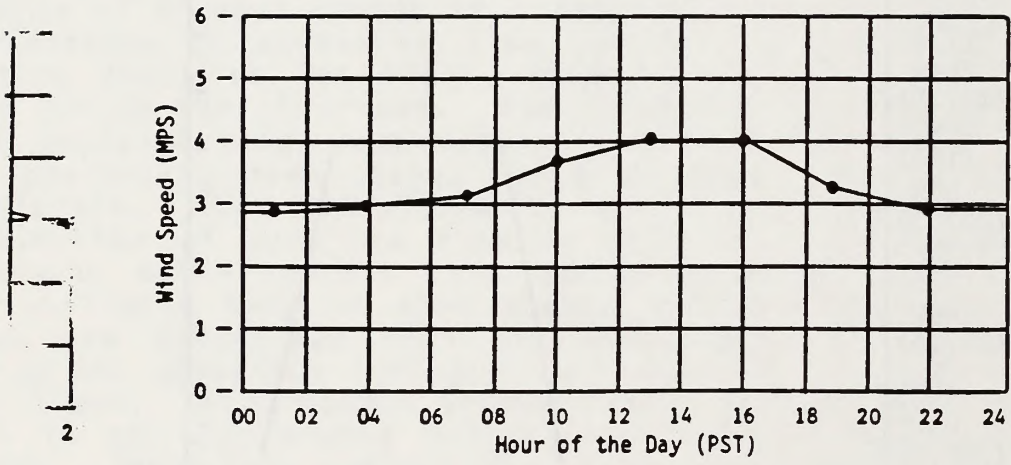

Figure 4.4-11

f. CA Diurnal Wind Speed Distribution at Red Bluff, CA (1972-1976)

12 and 4.4-13 for Sacramento and Red Bluff indicate a general preference for winds in the second wind speed class, that is, 4 to 6 knots. Wind speeds tend to be strongest at these stations during the summer months in response to surface heating effects and the influence of the seabreeze regime. Wind speeds are clearly lightest during fall and winter.

At Fallon and Lovelock, Nevada, the distribution shows a striking preference for winds in the first wind speed category during practically all seasons of the year. At these inland locations, light wind speeds dominate the distribution particularly during the fall and winter seasons. Winds in the first wind speed class, that is 0 to 3 knots, account for more than half of the distribution during winter and fall at Fallon and during winter at Lovelock. Wind speeds tend to be strongest at these stations during the spring and summer months. This occurs in response to surface heating effects which generally results in stronger afternoon wind speeds. At Lovelock, wind speeds are fairly evenly distributed over the first three wind speed classes during the summer season reflecting the influence of surface heating effects at this station. The trends indicated by the data presented in Figures 4.4-14 and 4.4-15 should be indicative of the general trends observed throughout the eastern two-thirds of the Susanville District.

Wind Speed as a Function of Wind Direction

The distribution of wind speed as a function of wind direction provides important information for dispersion meteorological studies. For example, when sensitive areas are situated near possible sources of pollutants, it is often beneficial to examine the mean wind speed of the flow from the direction of the source. Very low wind speeds are generally associated with stable or limited dispersion conditions and could serve to maximize pollutant impact in the sensitive area. High average wind speeds generally imply well-mixed conditions and would reduce downwind pollutant concentrations.

Data are not currently available for stations in the Susanville District which provide a breakdown on the wind speed as a function of wind direction. As indicated in previous sections, terrain and local meteorological effects will play an important role in the determination of the wind speed as a function of wind direction, as well as other dispersion meteorological parameters. For this reason, detailed available data from first order weather stations in the region such as Sacramento, Red Bluff, Fallon and Lovelock are not really appropriate for use in a description of the wind speed as a function of wind direction in the Susanville District.

On a traditional basis, wind speeds tend to be strongest for the most frequently occurring wind directions. The most frequently occurring wind directions generally are responsive to dominating synoptic scale influences, that is those imposed by

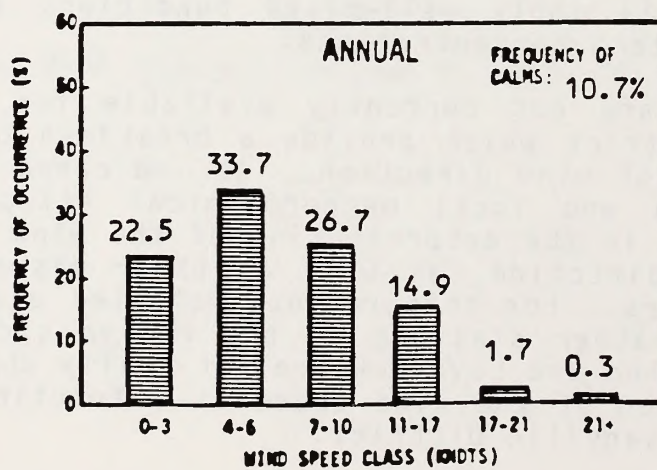
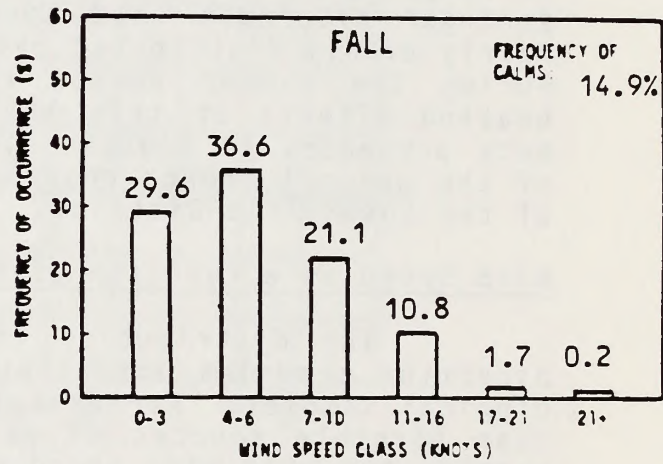
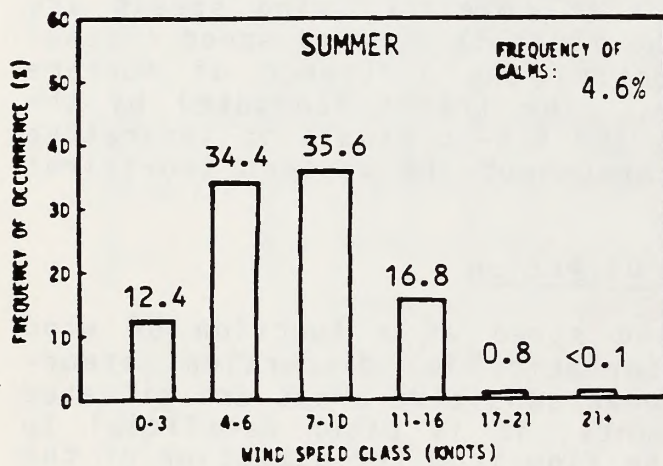
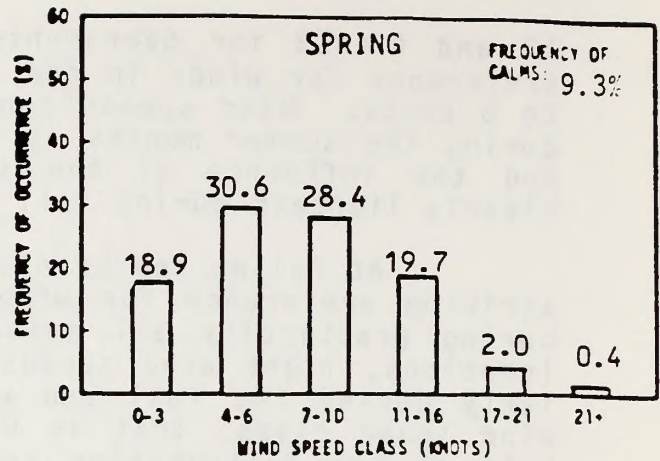
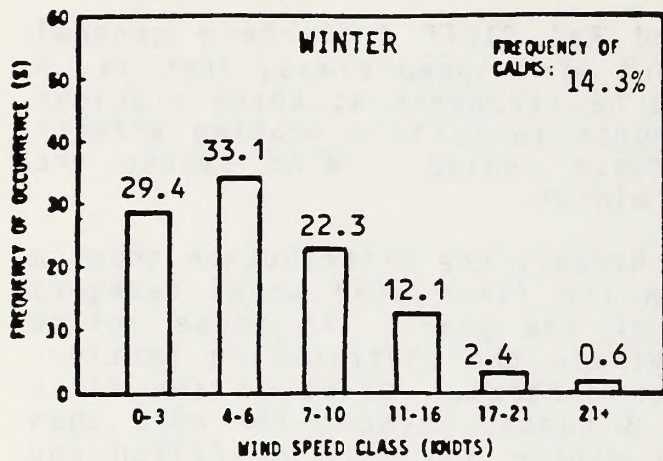

Figure 4.4-12
Annual-Seasonal Frequency of Occurrence of Key Wind Speed Classes
at Sacramento, California (1966-1970)

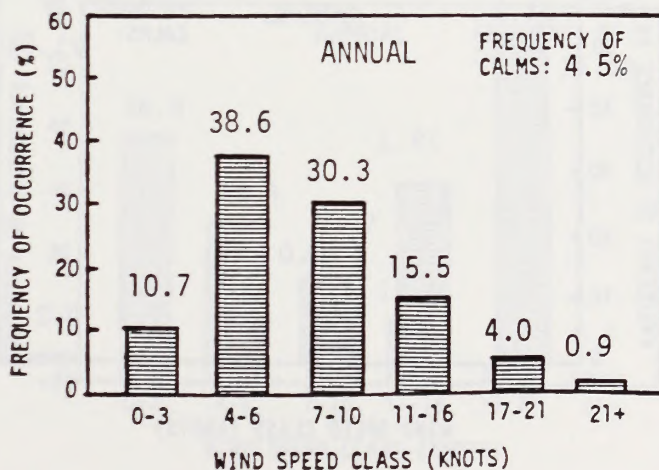
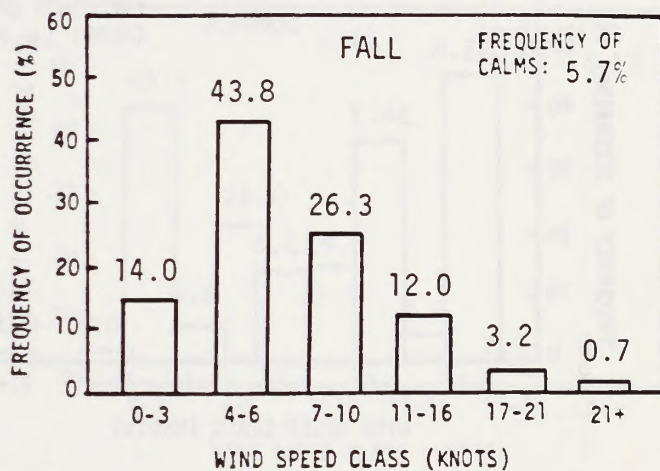
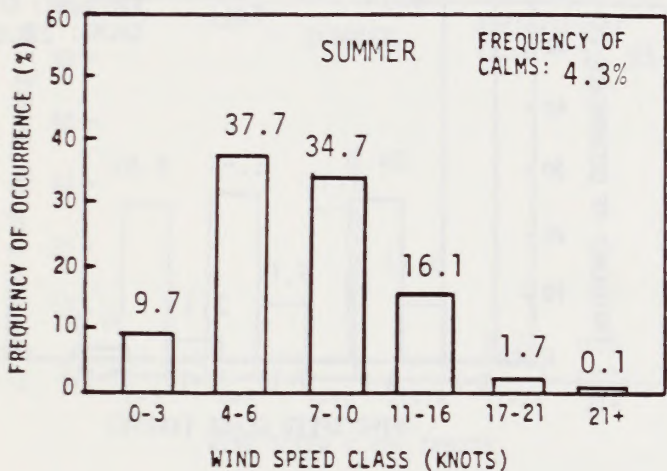
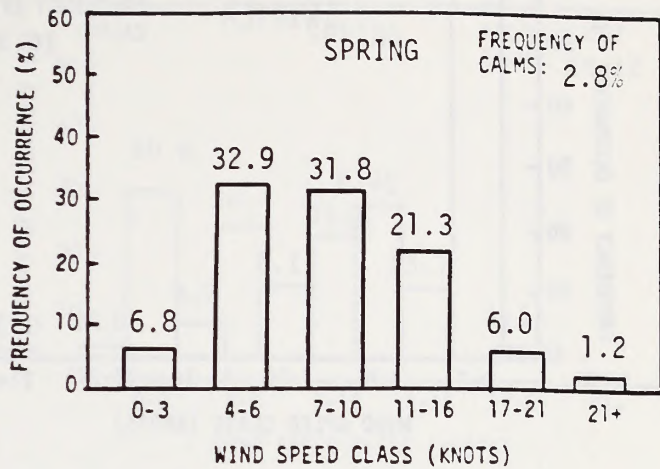
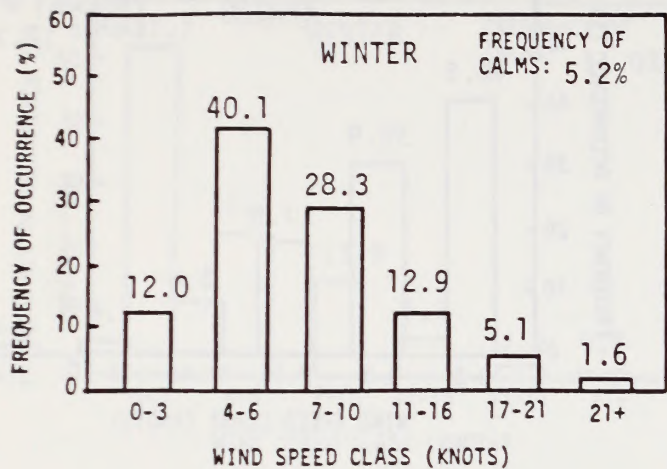

Figure 4.4-13
 Frequency of Occurrence of Key Wind Speed Classes
 at Red Bluff, California (1972-76)

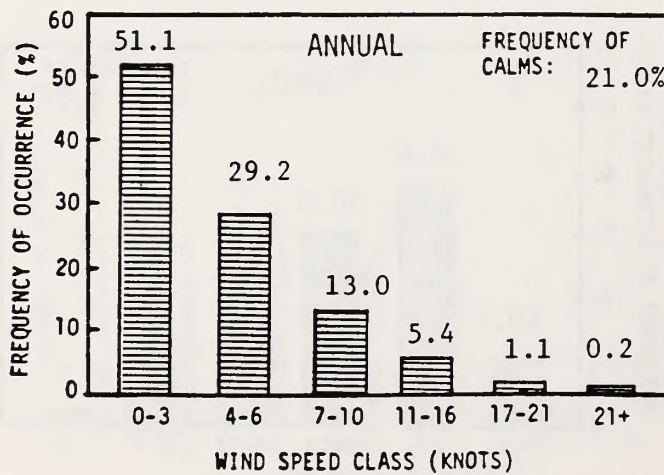
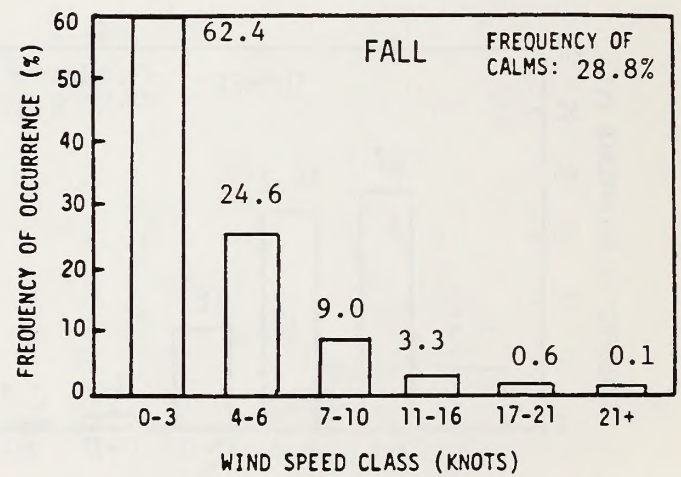
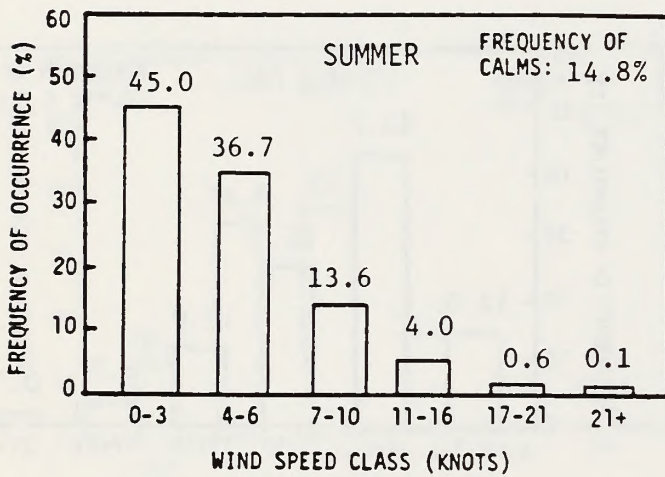
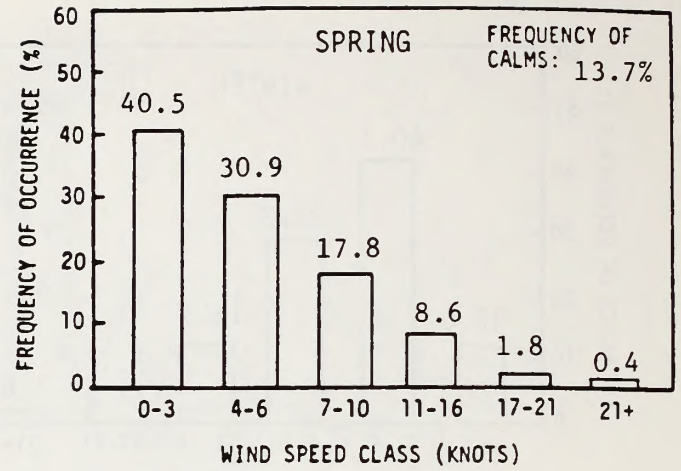
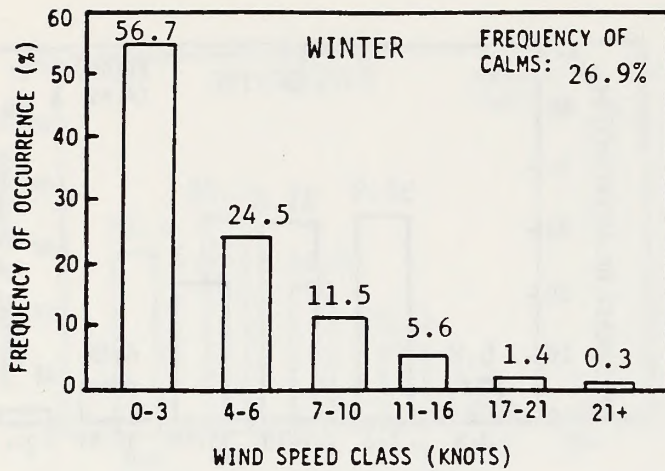

Figure 4.4-14
 Frequency of Occurrence of Key Wind Speed Classes
 at Fallon, Nevada (1966-1970)

Note: 1 MPS = 2.237 MPH = 1.944 Knots

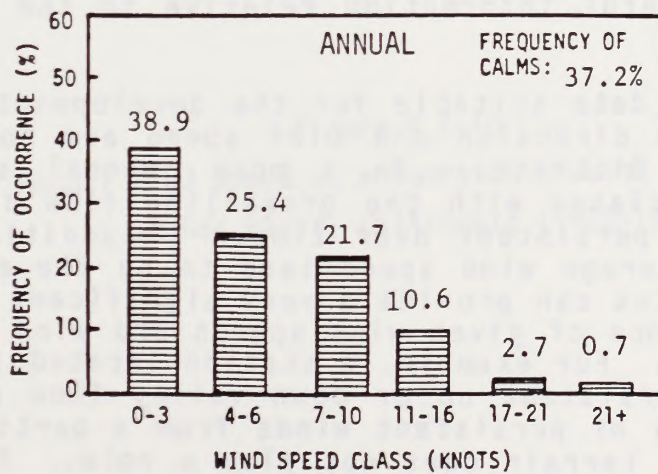
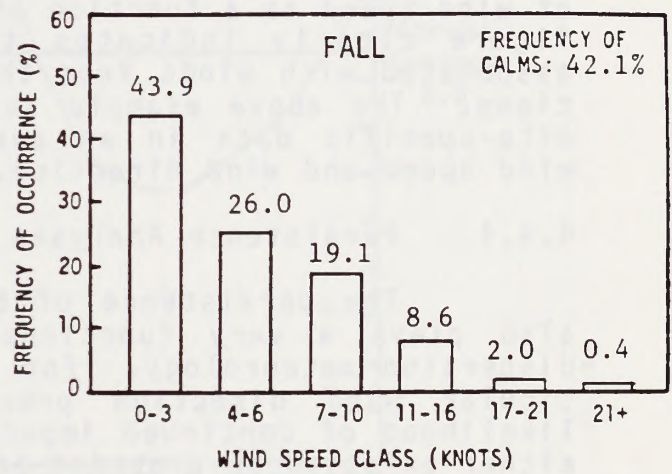
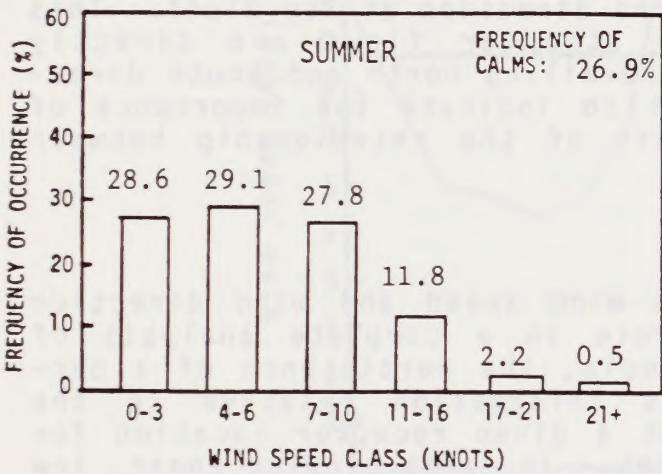
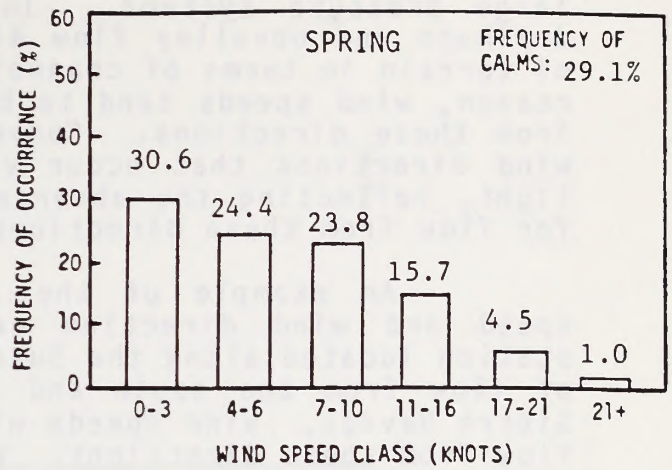
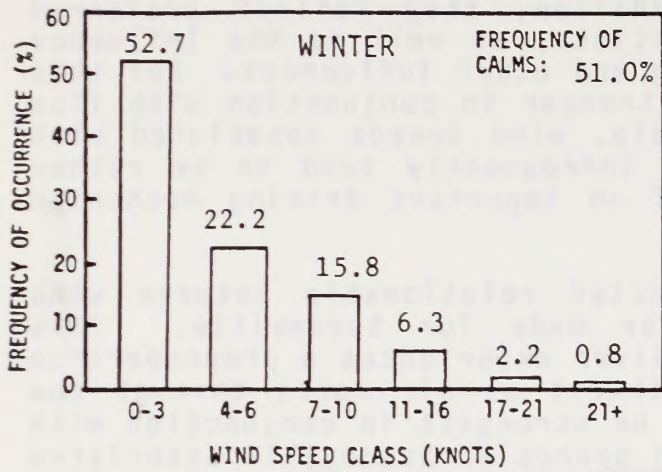

Figure 4.4-15
Frequency of Occurrence of Key Wind Speed Classes
at Lovelock, Nevada (1966-1970)

Note: L MPS - 2.237 MPH = 1.944 Knots

large pressure systems. In addition, they reflect preferred drainage and upvalley flow directions, as well as the influence of terrain in terms of channeling and other influences. For this reason, wind speeds tend to be stronger in conjunction with flow from these directions. Conversely, wind speeds associated with wind directions that occur very infrequently tend to be rather light, reflecting the absence of an important driving mechanism for flow from these directions.

An example of the expected relationship between wind speed and wind direction can be made for Susanville. This station located along the Susan River experiences a preponderance of flow from the south and southwest as air moves through the Sierra Nevada. Wind speeds will be strongest in conjunction with flow from these directions. Wind speeds at Susanville associated with flow from the northeast, on the other hand, should be fairly light as there is little driving mechanism to support flow from such a direction. Figure 4.4-16 provides an example distribution of wind speed as a function of wind direction at Red Bluff. This figure clearly indicates that stronger flows are directly associated with winds from the prevailing north and south directions. The above example serves to indicate the importance of site-specific data in an analysis of the relationship between wind speed and wind direction.

4.4.4 Persistence Analyses

The persistence of both wind speed and wind direction also plays a very functional role in a complete analysis of dispersion meteorology. For example, the persistence of a particular wind direction provides information relative to the likelihood of continued impact at a given receptor location for either existing or proposed sources. In terms of wind speed, low wind speeds can often provide a maximum impact in a given region particularly if they persist for any length of time. Therefore, the persistence of calms or lower wind speed classes can also provide very useful information relative to the overall dispersion potential.

Hourly data suitable for the development of persistence tables for wind direction and wind speed are not available for the Susanville District. In a more general sense, the wind directions associated with the prevailing flow in a region tend to be the most persistent over time. In addition, wind speeds close to the average wind speed tend to be the most persistent. Terrain influences can provide a very significant impact in terms of the persistence of given wind speeds and wind directions at a particular site. For example, a station located in a valley will tend to have persistent up or down valley flow and will show a higher frequency of persistent winds from a particular direction in a site where terrain does not play a role. For this reason, persistence analyses are very site-specific and will vary considerably for given locations within the Susanville District.

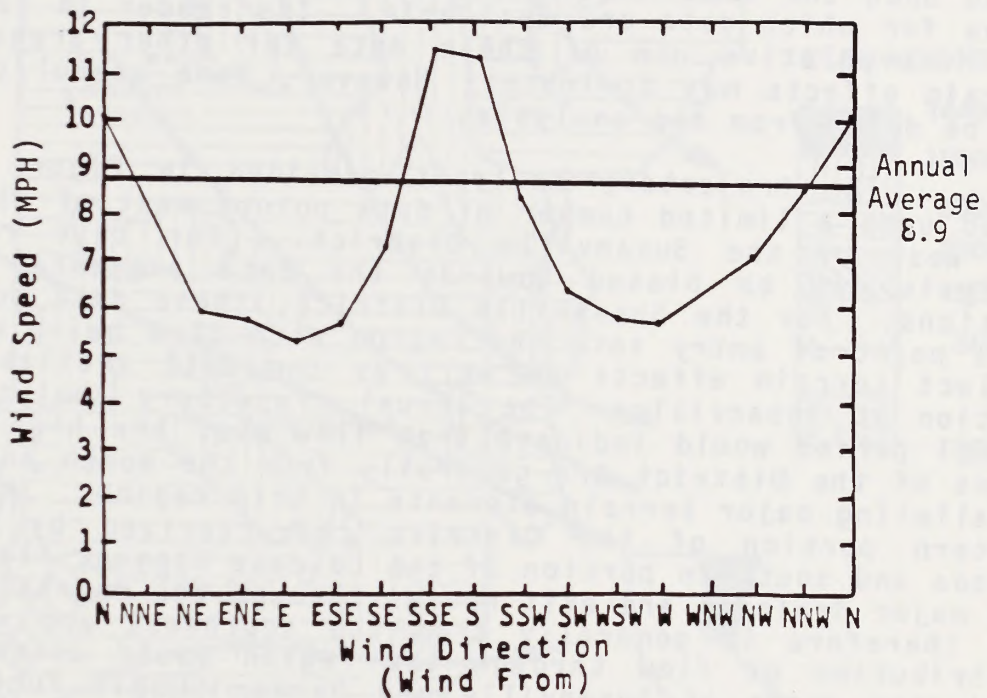

Figure 4.4-16
 Annual Wind Speed as a Function of Wind Direction
 at Red Bluff, California (1972-1976)

4.4.5 Trajectory Analyses

Trajectory analyses are used in dispersion meteorology to describe regional transport. Trajectory analyses are developed through the identification of prevailing flow at key stations to establish the mean flow over a large geographical area. These data are then useful in determining the probable large scale transport of pollutants.

It is not felt that the available data on prevailing flow is sufficient to definitively determine the actual trajectory of air parcels throughout this large area. However, Figure 4.4-17 provides an annual flow diagram for the region based upon the most frequently occurring wind direction at stations for which data are available. The reader is cautioned in the interpolative use of these data for other areas as local terrain effects may dominate. However, some useful conclusions can be drawn from the analysis.

The trajectory analysis provided in Figure 4.4-17 is based upon a limited number of data points most of which lie to the west of the Susanville District. For this reason, the analysis may be biased towards the data presented for these stations. For the Susanville District, these data points serve as a point of entry into the region with flow being modified to reflect terrain effects as well as the data available for the station at Susanville. The annual trajectory analysis for the annual period would indicate that flow over the high basin portions of the District are generally from the north and northwest paralleling major terrain elements in this region. In the southwestern portion of the District characterized by the Sierra Nevada and southern portion of the Cascade Ranges, flow parallels the major drainage and exit routes through the mountainous region and therefore is generally from the southwest and west. This distribution of flow through the region would account for the indicated winds at Susanville and Donner Summit further to the south while available data for Lovelock in Nevada indicates a preponderance of flow from the north which is well-aligned with the indicated distribution over the remainder of the Susanville District. Once again, the reader is cautioned in the use of these information as actual wind distributions at any particular site in the Susanville District will be heavily dependent upon local terrain effects.

4.4.6 Winds Aloft

Upper level winds provide a measure of the mean transport above the surface boundary layer. However, upper air data are only available for a very few NWS station locations and, for this reason, most major pollutant studies require the collection of onsite data to provide a measure of winds aloft. In California, upper air data are only routinely collected by the NWS at Oakland, Santa Monica and San Diego. Data are also collected at Medford, Oregon.

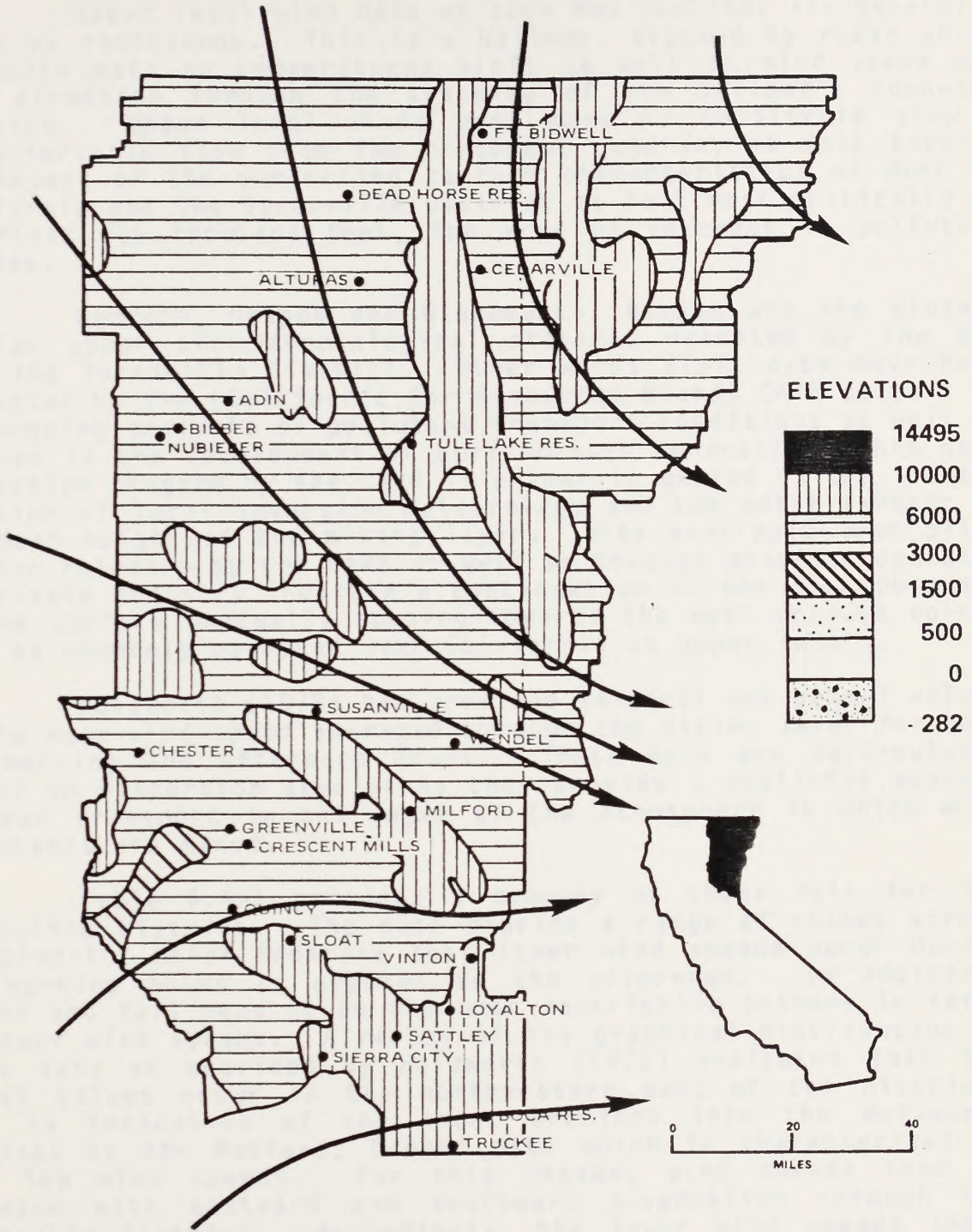

Figure 4.4-17
Annual Trajectory Analysis
for the Susanville District

Upper level wind data at such NWS stations are generally taken by radiosonde. This is a balloon, tracked by radar which transmits data on temperatures aloft as well as wind speed and wind direction through the tracking of the balloon's downwind position. Upper level winds over most of California show a characteristic flow from the northwest quadrant at most levels. The impact of the dominating terrain characteristics of much of California and the Susanville District is felt most critically in the first few thousand feet, the area of interest in pollution studies.

Medford, Oregon and Winnemucca, Nevada are the closest regular upper air meteorological stations operated by the NWS near the Susanville District. Other winds aloft data have been collected by the (California Air Resources Board) CARB as part of its ongoing analysis of pollutant transport conditions as well as for use in the development of burn/no-burn forecasts. This data collection program by the CARB is primarily geared to the identification of local inversion meteorology and the establishment of the mean height of the mixing layer. Data available from pilot balloon releases by the CARB as well as through programs operated by private industry indicate a continuation of the flow observed at the surface gradually turning towards the west through northwest as commonly observed over California at upper levels.

Holzworth (1972) has provided seasonal and annual values of the mean wind speed averaged through the mixing layer for both the morning and afternoon hours. These data are particularly useful in dispersion studies as they provide a realistic measure of mean transport in the layer of the atmosphere in which most pollutants are mixed.

Table 4.4-1 provides a summary of these data for the Susanville District. The data provide a range of values across the District which indicate that lower wind speeds occur during the morning hours as opposed to the afternoon. In addition, winter and fall tend to be the most restrictive seasons in terms of lower wind speeds. A review of the graphical distribution of these data as provided by Holzworth (1972) indicates that the lowest values occur in the northwestern part of the District. This is indicative of the input provided into the Holzworth analyses by the Medford, Oregon data which is characterized by very low wind speeds. For this reason, wind speeds tend to increase with eastward and southward progression through the Susanville District. Accordingly, the lower wind speeds indicated in Table 4.4-1 are most likely to occur in the northwest while the highest wind speeds will occur over the Nevada portion of the Susanville District.

The CARB data do not include data taken within the Susanville District. However, data available from Red Bluff in the Sacramento Valley indicated that wind speeds tend to be weak during summer afternoons in a comparison with other regions.

Table 4.4-1
 Seasonal and Annual Average Wind Speeds (MPH)
 in the Mean Mixing Layer Over the Susanville District
 (1960-1964)

	Morning	Afternoon
Winter	4.5 - 5.8	6.7 - 8.9
Spring	6.7 - 7.4	11.2 - 13.6
Summer	4.5	11.2 - 11.9
Fall	4.5 - 4.9	8.9 - 9.6
Annual	4.5 - 5.8	8.9 - 11.2

1 mps = 0.447 mph

However, these data may not be indicative of conditions in the more mountainous rugged Susanville District where an analysis of data provided by Holzworth indicates that wind speeds tend to be lightest during winter and fall.

4.5 ATMOSPHERIC STABILITY

The definition of atmospheric stability throughout the Susanville District is a critical component of the dispersion meteorological analysis. Section 4.2.2 provides a detailed discussion of atmospheric stability and its role in defining the dispersion of airborne effluents. Figure 4.5-1, which also appears in Section 4.2.2, summarizes the dispersion characteristics associated with the various stability categories for the traditional dispersion scenarios. This section provides analyses that are designed to identify specific characteristics of atmospheric stability. These analyses include:

- o Seasonal and Annual Distributions
- o Diurnal Distributions
- o Persistence Analyses
- o Stability Wind Roses

These analyses describe a key component of the dispersion characteristics of the Susanville District. Data are unfortunately available for only a few key stations in the region and the reader is cautioned in the use of these analyses, particularly in areas of rugged terrain or other locations not well represented by the available data.

4.5.1 Seasonal and Annual Stability Distributions

Annual stability distributions provide a means of quantifying the atmospheric dispersive power of an area in an easily comparative form. The seasonal variations in stability reflect the extent to which the dispersive power of the atmosphere changes with the seasons.

The ability of the local atmosphere to disperse airborne effluents from specific source types can be discussed in terms of atmospheric stability. When the atmosphere is stably stratified, the impact of ground level, non-buoyant emissions, will be greatest as both vertical and lateral diffusion are restricted. Examples of such emissions include automobile exhaust and fugitive dust. Typical similar sources which might impact BLM lands include range management activities and the use of unpaved surface roads. The lower atmosphere is most likely to be stable on calm clear nights when cold air tends to collect at lower elevations. Emissions from tall stacks under such conditions will have little or no impact at ground level as the plume remains relatively intact aloft. Fall and winter are the seasons when such conditions occur most frequently in California and in most areas of the United States. The impact of ground level sources is therefore at a maximum during these seasons.

Intense surface heating results in considerable convective activity and unstable conditions. Under such conditions, vertical diffusion is considerable and "fumigation" can occur as

Stability Category A-C; Looping

Stability Category D; Coning

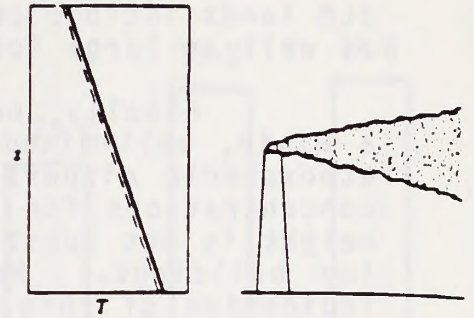
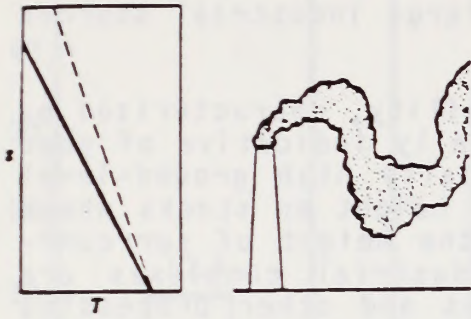

Stability Category E-G; Fanning

Stability Categories As Noted; Lofting

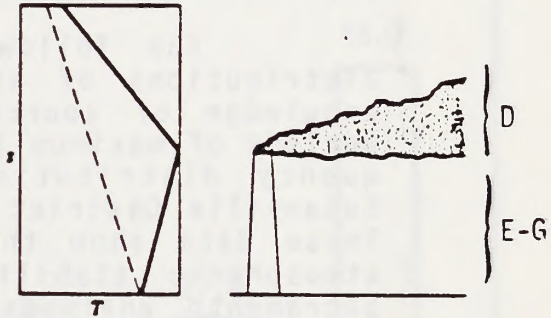
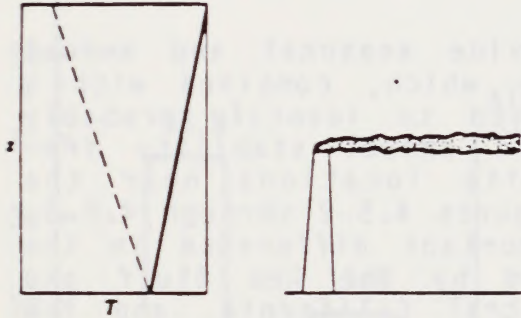

Stability Categories As Noted; Fumigation

Stability Categories As Noted; Trapping Inversion

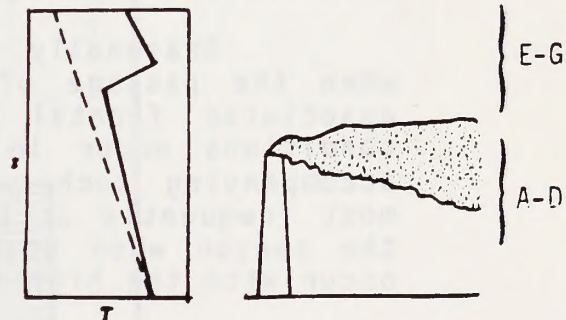
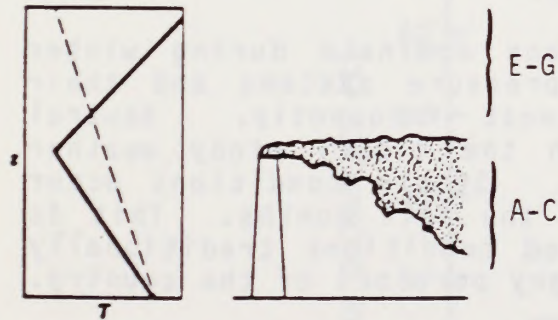

Figure 4.5-1
Typical Plume Behavior*

* Plume behavior influenced by the temperature lapse rate above and below the release height. The dashed lines in the profiles are the adiabatic lapse rates, included for reference, while the solid lines indicate the actual lapse rate. The Pasquill stability categories are also provided.

emissions from elevated sources are brought rapidly to the surface creating maximum ground-level concentrations. Examples of large elevated pollutant sources which could potentially impact BLM lands include power plants and other large industrial sources as well as large forest fires.

Finally, neutral atmospheric stability, characterized by a windy, well-mixed atmosphere, and generally indicative of good atmospheric dispersion, can result in locally high ground-level concentrations for stacks of intermediate height or stacks whose height is not substantially greater than the height of surrounding buildings. Most moderate sized industrial complexes are indicative of this source type; refineries and other processing industries serve as typical examples. In such cases, strong winds can bring the plume rapidly to the surface, resulting in high ground-level pollutant concentrations in a condition known as "downwash". Neutral conditions may also result in the re-entrainment of loose dust and soil particles associated with deserts and overgrazed arid lands. Reduced visibility and increased atmospheric particulate loading may occur in nearby populated areas as a result.

The following discussion provide seasonal and annual distributions of atmospheric stability which, combined with a knowledge of source types, can be used to identify probable periods of maximum impact. Seasonal and annual stability frequency distributions for various site locations near the Susanville District are provided in Figures 4.5-2 through 4.5-5. These data show that there is an important difference in the atmospheric stability data as defined by the Red Bluff and Sacramento analyses indicative of Central California, and the Fallon and Lovelock, Nevada analyses indicative of the eastern portions of the Susanville District.

Sacramento and Red Bluff both show a maximum for stable conditions. However, neutral conditions occur almost as frequently as these two categories, accounting for between 70 and 80 percent of the annual distribution. Unstable conditions occur with the lowest frequency at each site.

Seasonally, neutral conditions dominate during winter when the passage of migratory low pressure systems and their associated frontal systems occurs most frequently. Neutral conditions occur in association with the cloudy windy weather accompanying such pressure patterns. Stable conditions occur most frequently at both sites during the fall months. This is the season when stable low wind speed conditions traditionally occur with the highest frequency in many portions of the country.

At Fallon and Lovelock, Nevada, stable conditions clearly dominate the distribution accounting for nearly half of the annual distribution at Fallon. Neutral conditions occur much less frequently here than in Central California reflecting the reduced frequency of cloudy, windy and rainy conditions conducive

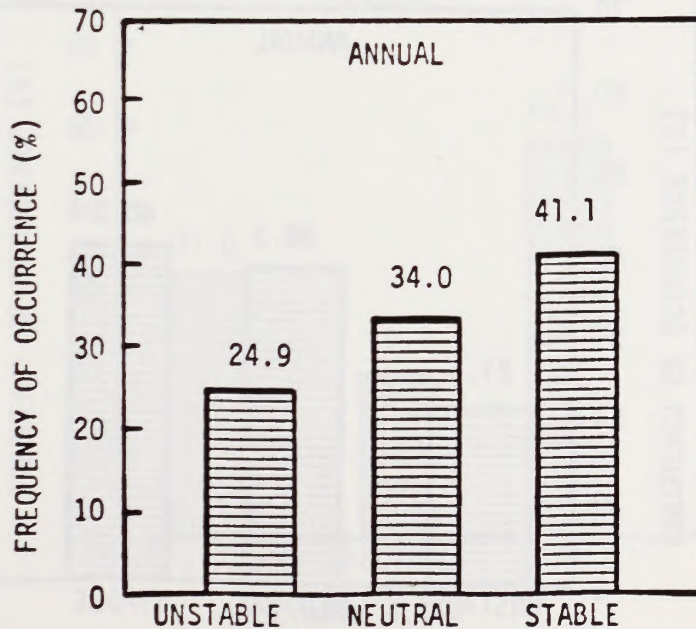
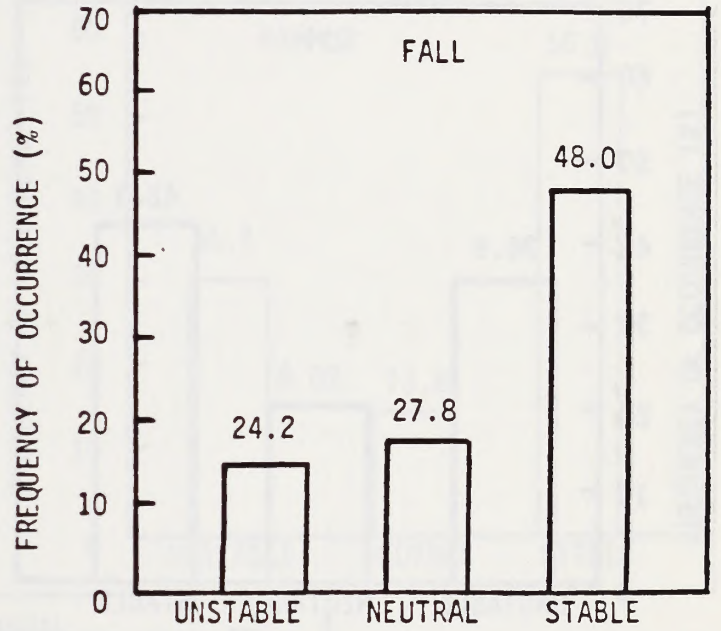
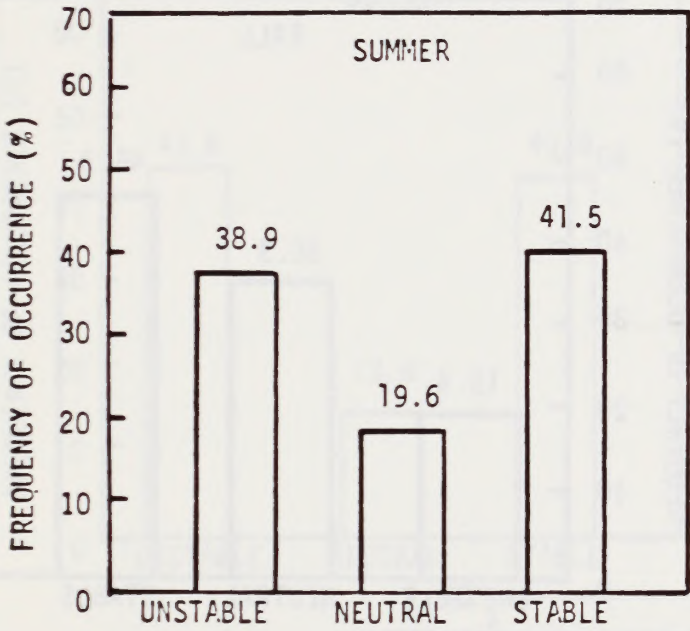
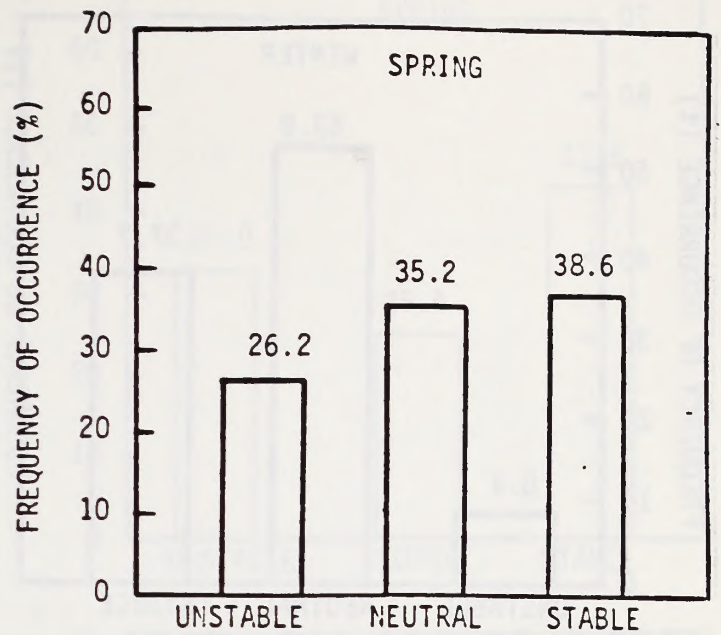
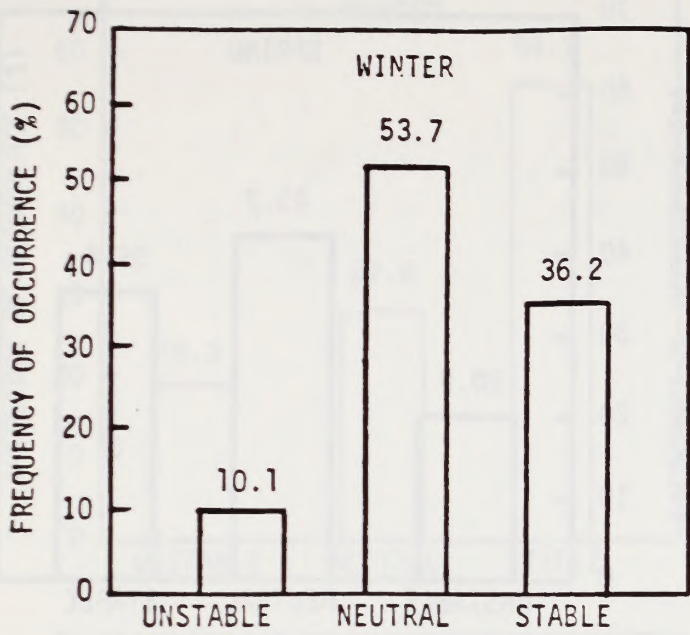

Figure 4.5-2

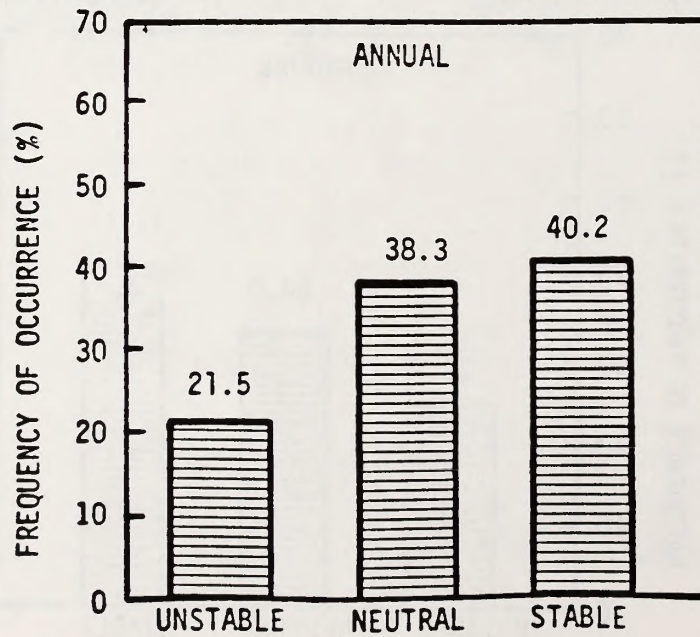
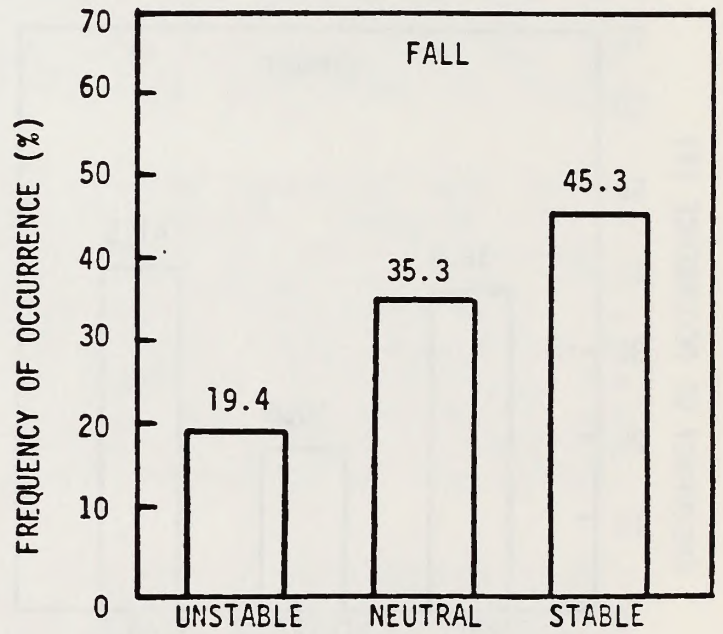
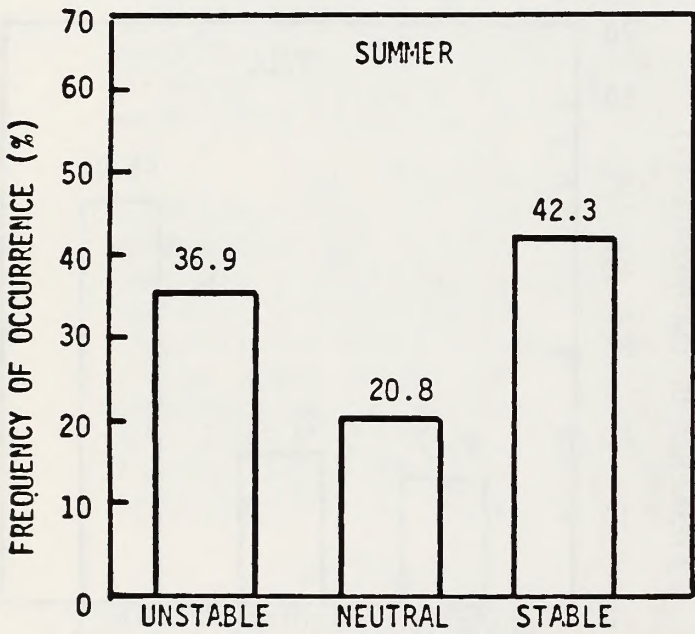
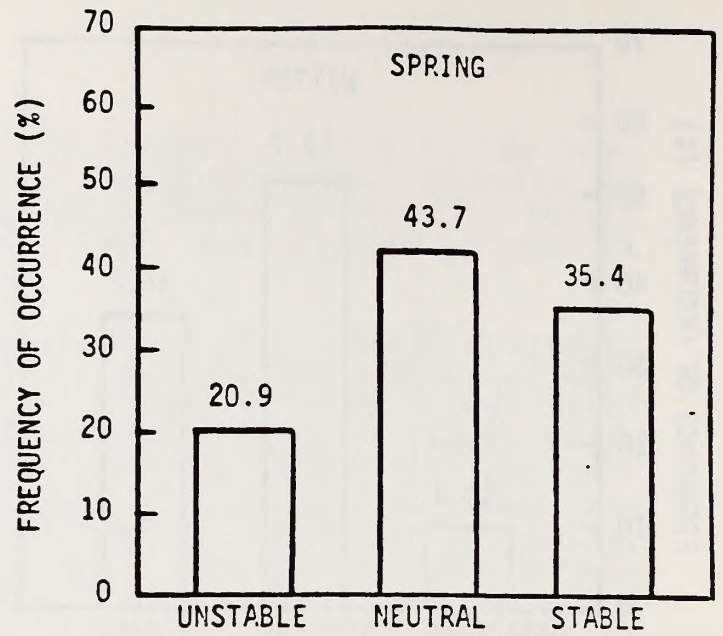
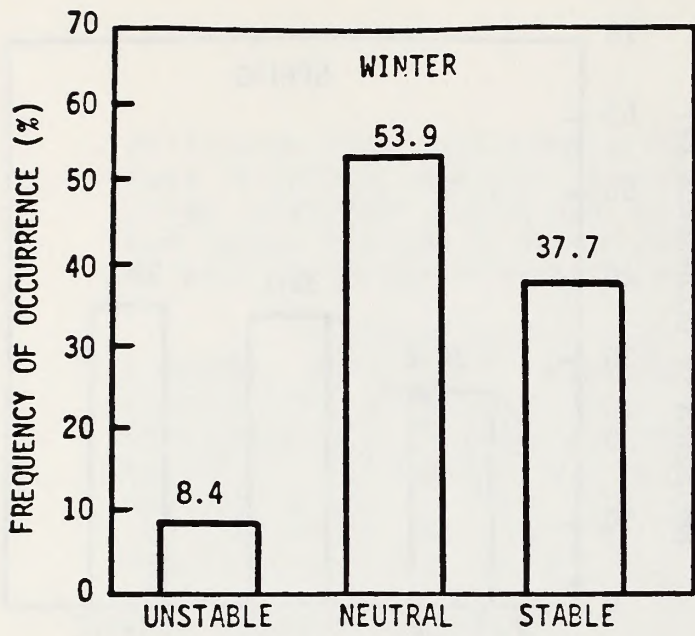

Figure 4.5.3

Seasonal/Annual Distribution of Atmospheric Stability-Red Bluff, CA (1972-76)

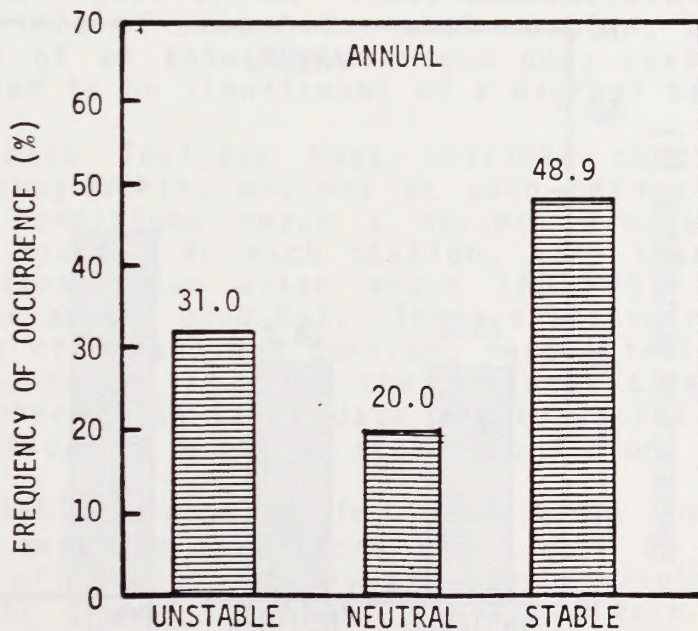
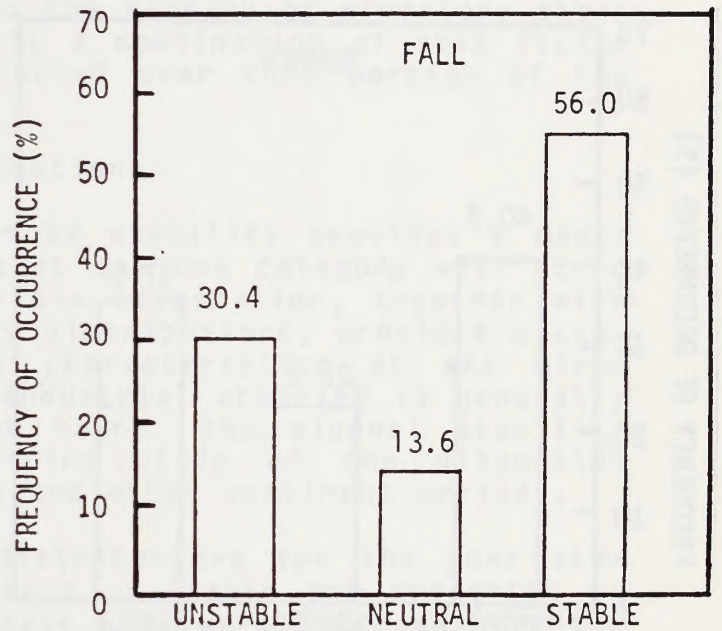
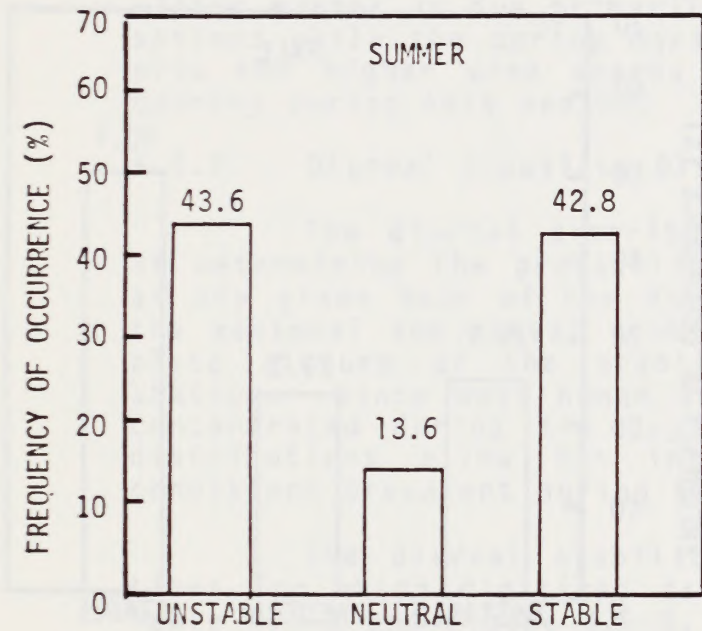
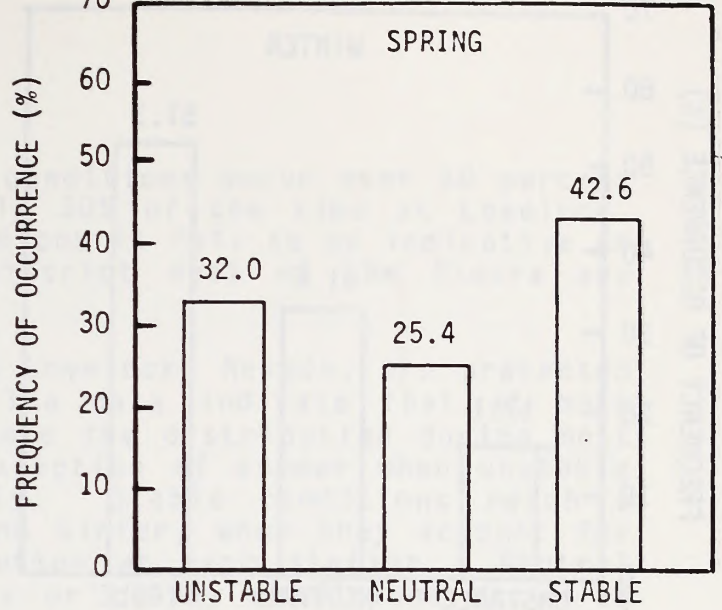
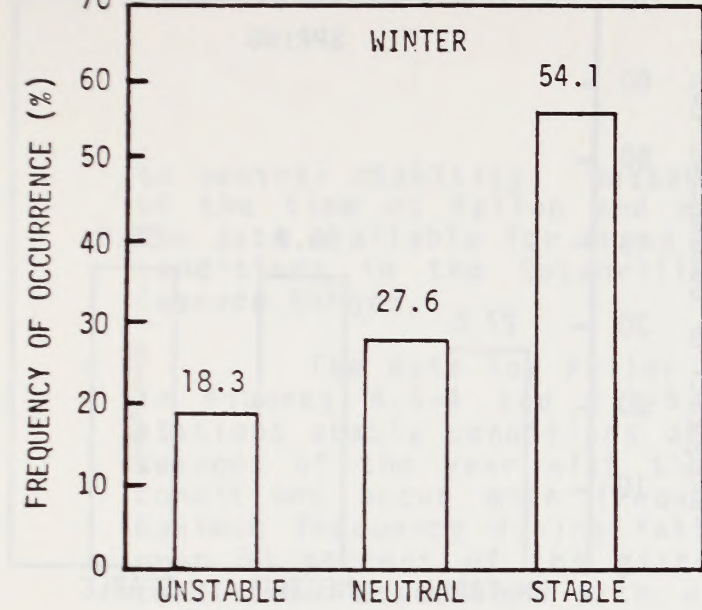

Figure 4.5-4
 Seasonal/Annual Distribution of Atmospheric Stability
 Fallon, Nevada (1966-1970) 198

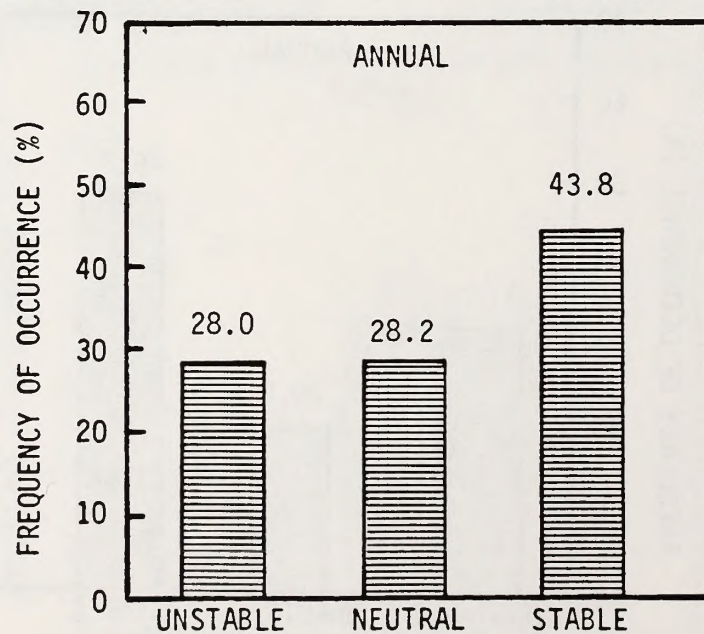
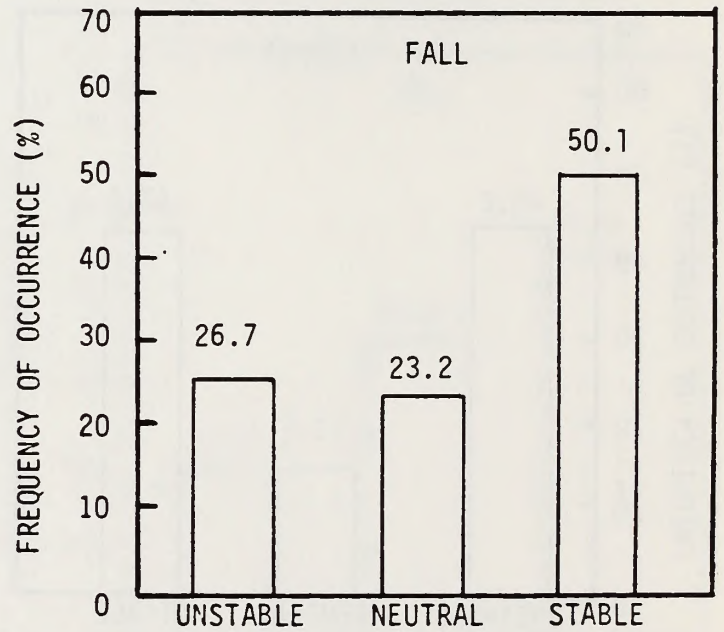
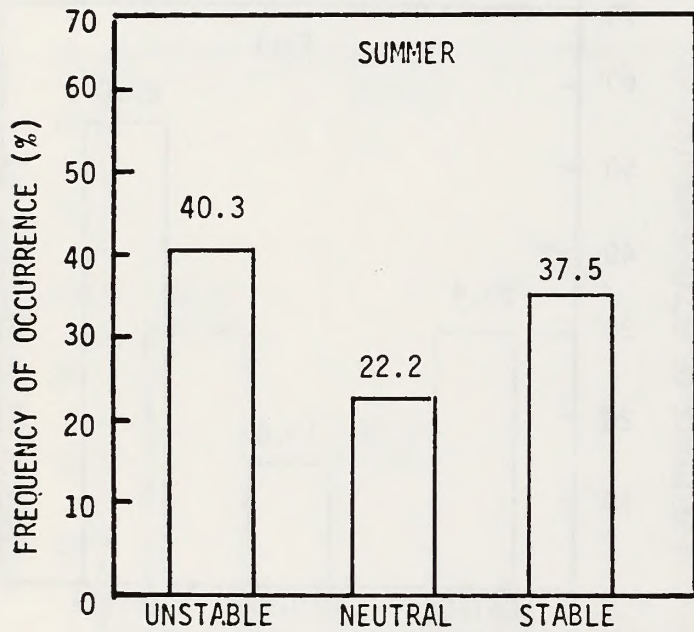
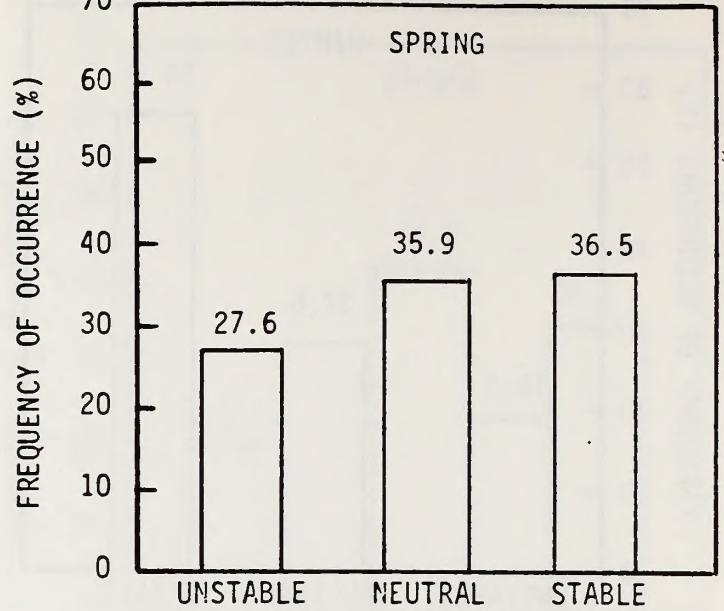
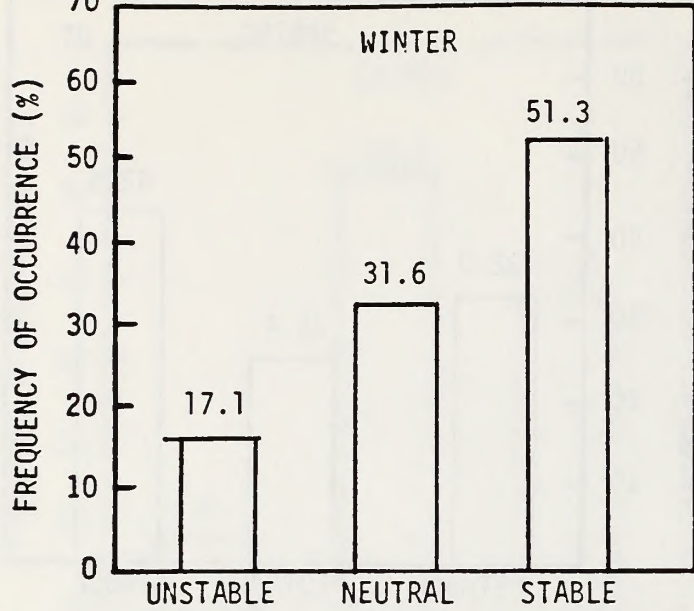

Figure 4.5-5
Seasonal/Annual Distribution of Atmospheric Stability
Lovellock, Nevada (1966-1970)

to neutral stability. Unstable conditions occur over 30 percent of the time at Fallon and nearly 30% of the time at Lovelock. The data available for these stations is felt to be indicative of conditions in the Susanville District east of the Sierra and Cascade Ranges.

The data for Fallon and Lovelock, Nevada, are presented in Figures 4.5-4 and 4.5-5. The data indicate that at both stations stable conditions dominate the distribution during most seasons of the year with the exception of summer when unstable conditions occur more frequently. Stable conditions reach a maximum frequency during fall and winter, when they account for over 50 percent of the distribution at each station. Neutral conditions associated with windy or cloudy conditions occur as expected with a maximum frequency during winter and spring. The winter maxima is due primarily to the passage of migratory storm systems while the spring maxima is a combination of this factor plus the higher wind speeds observed over this portion of the country during this season.

4.5.2 Diurnal Stability Distributions

The diurnal distribution of stability provides a means of determining the probability that any one category will occur at any given hour of the day. This information, together with the seasonal and annual stability distributions, provides a complete picture of the stability characteristics at any given station. Since most human and industrial activity is generally concentrated during the daylight hours, the diurnal stability distributions allow for intensified study of the dispersion conditions prevalent during those and other pertinent periods.

The diurnal stability distributions for the four stations for which digitized data were available are presented in Table 4.5-1 and Figure 4.5-6. These data were averaged over the respective periods of record for each station, and as such are representative of an annually averaged day; seasonal variations are not expected to be significant on a diurnal basis.

The data indicate that unstable conditions reach a maximum frequency during mid-day at each of the three stations while stable conditions reach a maximum frequency during the early morning hours. At each station, very sharp increases in stable conditions occur after about 1600 PST and very sharp decreases occur around 0800 PST. These times correspond with the average limits of sunset and sunrise, respectively, on an annual basis. The technique used by the National Climatic Center to develop atmospheric stability data precludes the development of unstable conditions at night or stable conditions during the day.

The table presented in Table 4.5-1 and Figure 4.5-6 indicate that unstable conditions occur over 60 percent of the time at Red Bluff during mid-day and approximately 80 percent of the time at the Nevada stations. This reflects the preference

Table 4.5-1
Diurnal Frequency Distribution of Stability
in the Susanville District

Hour	Red Bluff 1972-1976			Lovelock 1966-1970			Fallon 1966-1970		
	U	N	S	U	N	S	U	N	S
1	0.0	26.0	74.0	0.0	17.2	82.8	0.0	10.9	89.1
2	0.0	*	*	0.0	*	*	0.0	9.5	90.5
3	0.0	*	*	0.0	*	*	0.0	9.2	90.8
4	0.0	27.3	72.7	0.0	16.7	83.3	0.0	8.9	91.1
5	0.0	*	*	0.0	*	*	0.0	8.6	91.4
6	0.0	*	*	0.0	*	*	0.0	9.5	90.5
7	26.2	45.6	28.1	41.3	24.6	34.1	27.0	14.2	63.8
8	*	*	0.0	*	*	0.0	48.3	15.0	36.8
9	*	*	0.0	*	*	0.0	68.4	17.9	13.6
10	51.5	48.4	0.0	76.7	23.3	0.0	81.1	18.8	0.0
11	*	*	0.0	*	*	0.0	80.6	19.4	0.0
12	*	*	0.0	*	*	0.0	80.9	19.2	0.0
13	61.4	38.6	0.0	70.7	29.3	0.0	79.9	20.1	0.0
14	*	*	0.0	*	*	0.0	77.0	23.1	0.0
15	*	*	0.0	*	*	0.0	72.9	27.2	0.0
16	32.6	59.8	7.6	35.2	48.4	16.4	63.8	36.2	0.0
17	0.0	*	*	0.0	*	*	43.2	40.5	16.3
18	0.0	*	*	0.0	*	*	25.6	40.0	35.1
19	0.0	33.9	66.1	0.0	39.0	61.0	2.7	41.5	55.8
20	0.0	*	*	0.0	*	*	0.0	24.8	75.2
21	0.0	*	*	0.0	*	*	0.0	20.3	79.7
22	0.0	26.4	73.6	0.0	27.0	73.0	0.0	18.3	81.7
23	0.0	*	*	0.0	*	*	0.0	73.8	86.2
24	0.0	*	*	0.0	*	*	0.0	11.4	88.6

U = Unstable N = Neutral S = Stable
* = Eight observations per day

Red Bluff
(1972-1976)

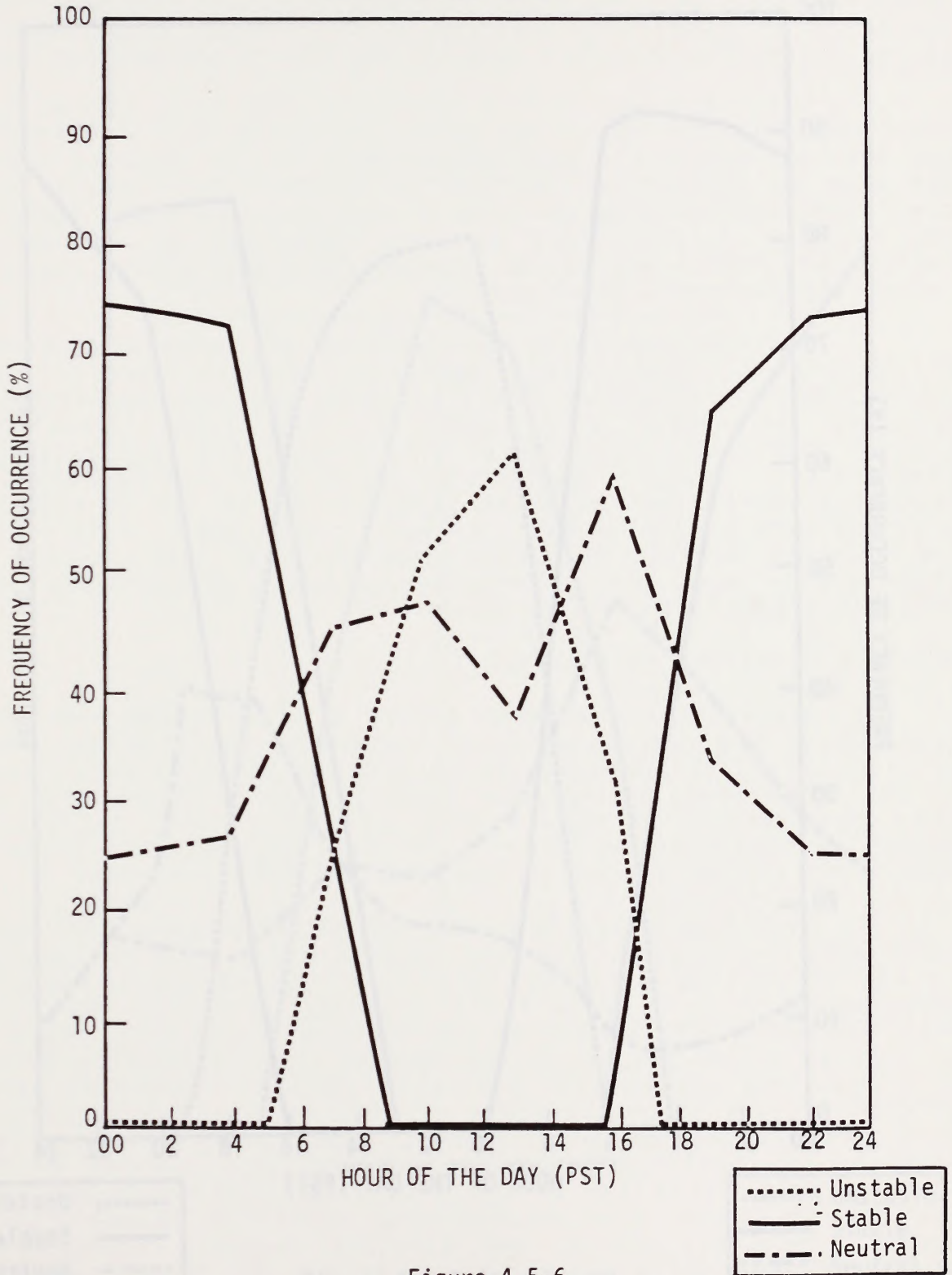

Figure 4.5-6
Diurnal Distribution of Atmospheric Stability
in the Susanville District

FALLON
(1966-1970)

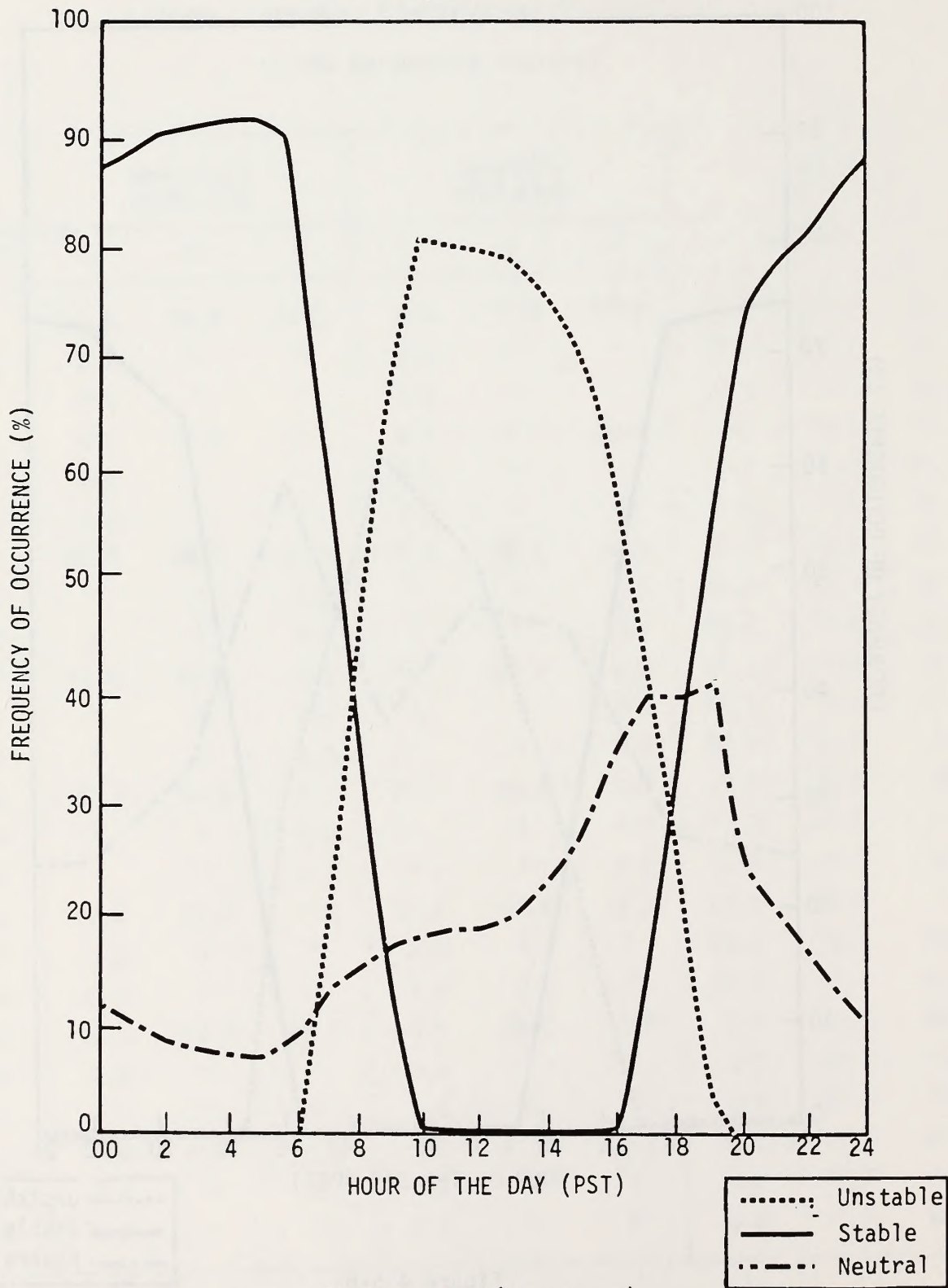

Figure 4.5-6 (Continued)
Diurnal Distribution of Atmospheric Stability
in the Susanville District

LOCKLOCK
(1966-1970)

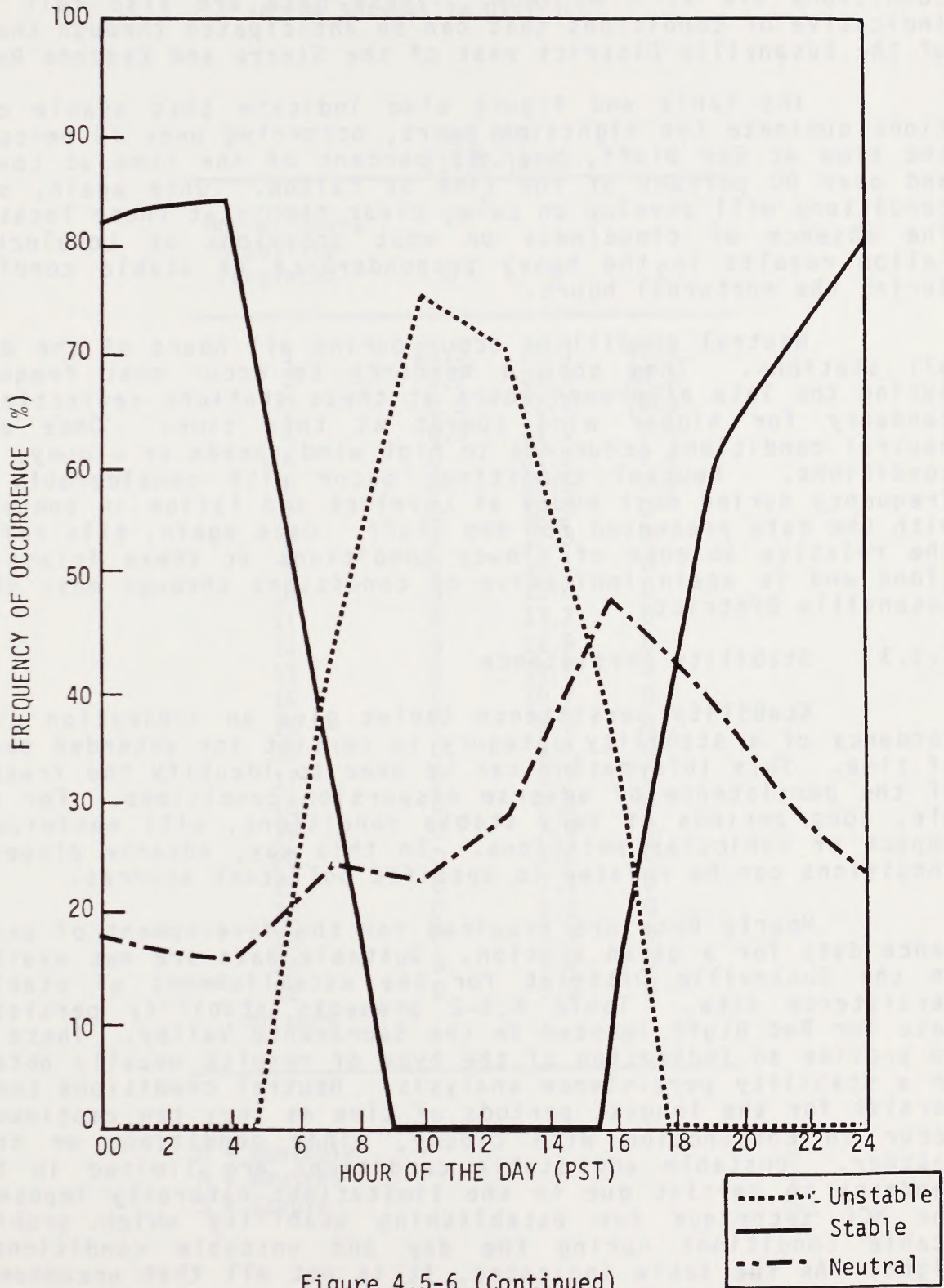

Figure 4.5-6 (Continued)
Diurnal Distribution of Atmospheric Stability
in the Susanville District

for the development of unstable conditions during mid-day as strong surface heating effects under cloudless skies results in considerable convective activity. This is particularly true at dry inland stations such as Lovelock and Fallon where cloudy conditions are at a minimum. These data are also felt to be indicative of conditions that can be anticipated through the bulk of the Susanville District east of the Sierra and Cascade Ranges.

The table and figure also indicate that stable conditions dominate the nighttime hours, occurring over 70 percent of the time at Red Bluff, over 80 percent of the time at Lovelock and over 90 percent of the time at Fallon. Once again, stable conditions will develop on calm, clear nights at these locations. The absence of cloudiness on most occasions at Lovelock and Fallon results in the heavy preponderance of stable conditions during the nocturnal hours.

Neutral conditions occur during all hours of the day at all stations. They show a tendency to occur most frequently during the late afternoon hours at these stations reflecting the tendency for higher wind speeds at this time. Once again, neutral conditions occur due to high wind speeds or cloudy, rainy conditions. Neutral conditions occur with considerably less frequency during most hours at Lovelock and Fallon in comparison with the data presented for Red Bluff. Once again, this reflects the relative absence of cloudy conditions at these inland stations and is again indicative of conditions through most of the Susanville District.

4.5.3 Stability Persistence

Stability persistence tables give an indication of the tendency of a stability category to persist for extended periods of time. This information can be used to identify the frequency of the persistence of adverse dispersion conditions. For example, long periods of very stable conditions, will maximize the impact of vehicular emissions. In this way, adverse dispersion conditions can be related to specific pollutant sources.

Hourly data are required for the development of persistence data for a given station. Suitable data are not available in the Susanville District for the establishment of stability persistence data. Table 4.5-2 presents stability persistence data for Red Bluff located in the Sacramento Valley. These data do provide an indication of the type of results usually obtained in a stability persistence analysis. Neutral conditions tend to persist for the longest periods of time as they can continuously occur in conjunction with cloudy, windy conditions or stormy weather. Unstable and stable conditions are limited in their tendency to persist due to the limitations naturally imposed by the NCC technique for establishing stability which prohibits stable conditions during the day and unstable conditions at night. As the table indicates, it is not all that uncommon for neutral conditions to persist for a day or more. Such persis-

Table 4.5-2
 Persistence of Stability Class
 (Percentage of Total Observations)
 in the Susanville District

No. of Hours Stability Persisted	Red Bluff (1972-1976)		
	U	N	S
1	21.5	38.3	40.4
2	9.7	31.9	28.3
3	2.3	27.4	18.5
4	0.3	24.1	8.6
5	0	21.8	2.4
6	0	20.5	0.2
7	0	18.9	0
8	0	17.3	0
9	0	16.1	0
10	0	15.0	0
11	0	13.7	0
12	0	12.9	0
13	0	11.7	0
14	0	10.7	0
15	0	9.8	0
16	0	9.4	0
17	0	8.7	0
18	0	8.3	0
19	0	7.9	0
20	0	7.6	0
21	0	7.3	0
22	0	6.3	0
23	0	5.5	0
24	0	5.2	0
25	0	5.0	0
or more			

U = Unstable
 N = Neutral
 S = Stable

tence should not occur as frequently in the dryer more inland Susanville District; however, the table does provide an indication of typical stability persistence data.

4.5.4 Stability Wind Roses

Stability wind roses provide information useful for determining land use alternatives in terms of the probable transport and dispersion of airborne pollutants. The data are presented for three major classes which represent a combination of the Pasquill categories; (1) unstable (A-C), (2) neutral (D) and (3) stable (E-G). As noted earlier, maximum ground level pollution impacts vary with each stability category as well as with source emission types and levels.

Once again, stable conditions are generally characterized by light winds, hence, wind roses for this stability category are valuable in determining probable levels and areas of maximum impact from the low-level, non-buoyant emissions associated with many rural land uses, such as grazing and farming. Alternatively, neutral conditions with high wind speeds or unstable conditions can result in maximum impacts from elevated plume sources associated with heavier industrial activity.

Figures 4.5-7 through 4.5-9 provide stability wind roses as well as the annual wind rose for Red Bluff, Lovelock and Fallon near the Susanville District. As indicated earlier, stability class I refers to unstable conditions, stability class II refers to neutral conditions, and stable conditions are represented by stability class III. Each of the stability wind roses can be summed for comparison with the annual wind rose also depicted on each figure.

Figure 4.5-7 indicates that at Red Bluff the neutral wind rose agrees very closely with the annual wind rose. The unstable and stable wind roses are much more directionally dependent and reflect the influence of terrain and mesoscale features. Unstable conditions are generally associated with winds from the northeast quadrant. The overall frequency of unstable conditions, however, is quite low. Light upslope flow conditions represented by winds from the east and northeast at Red Bluff are primarily associated with unstable conditions. Stable conditions, on the other hand, reflect the influence of drainage flow from the southwest at Red Bluff as cool air drains into the Central Valley from the Coast Range lying to the west. The strong influence of terrain on the stable and unstable roses is indicative of conditions that can be expected in the Susanville District. Figure 4.4-8 indicates that at Fallon little directional preference is apparent for the various stability roses. This indicates that at this station terrain induced flow is not playing a dominating role in the distribution of winds as a function of stability class. Figure 4.4-9, which provides the stability roses for Lovelock does indicate a preference for drainage flow for winds from the west and north as

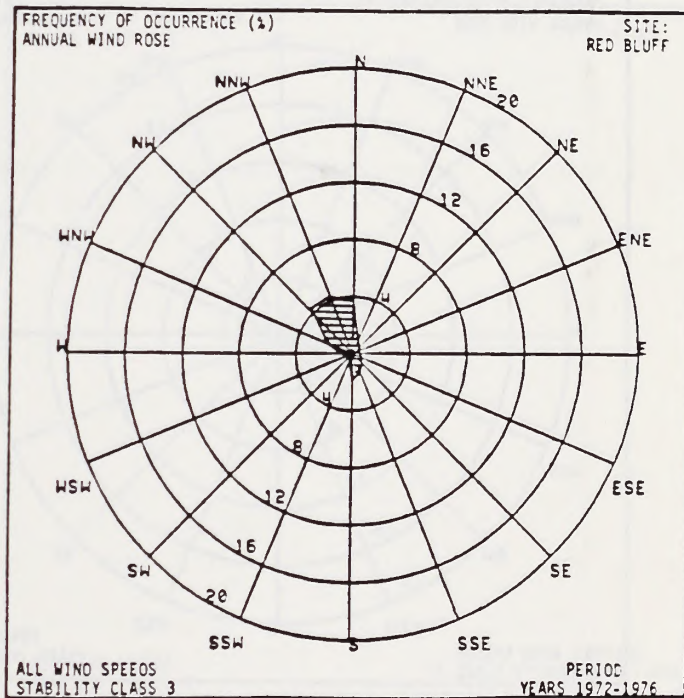
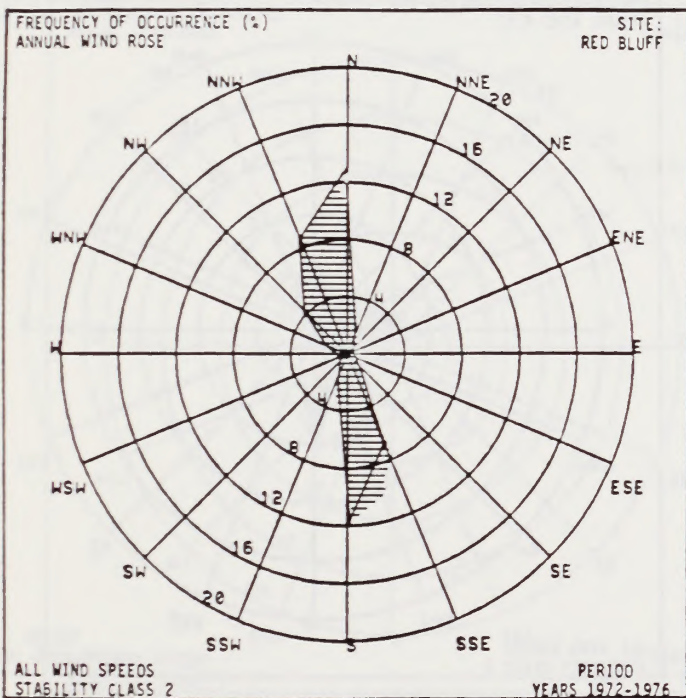
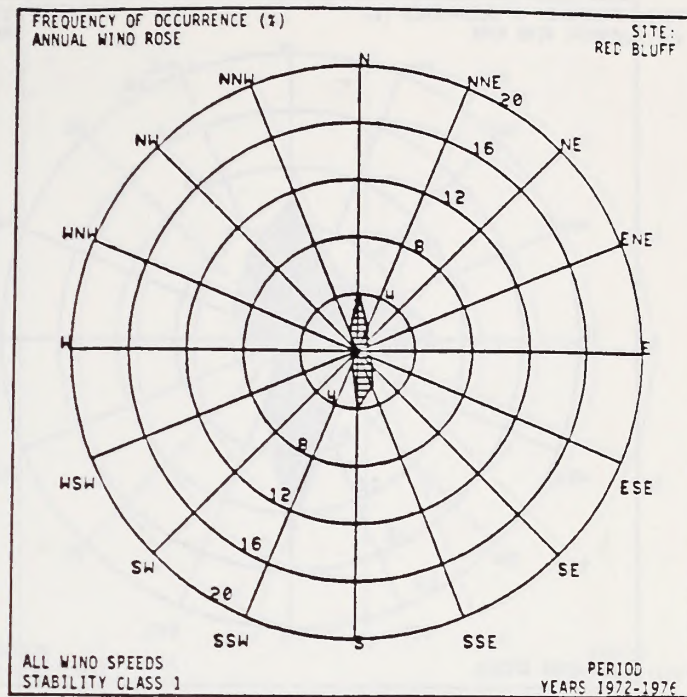
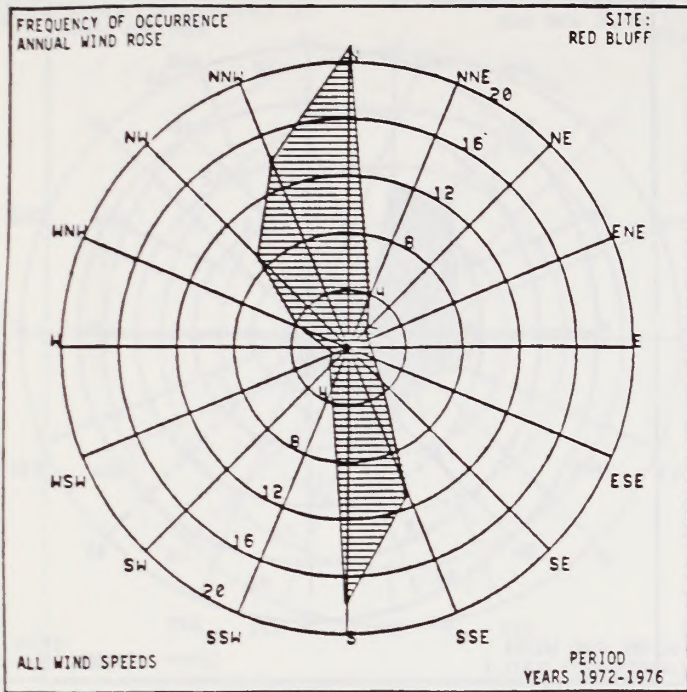

Figure 4.5-7
Stability Wind Roses for Red Bluff

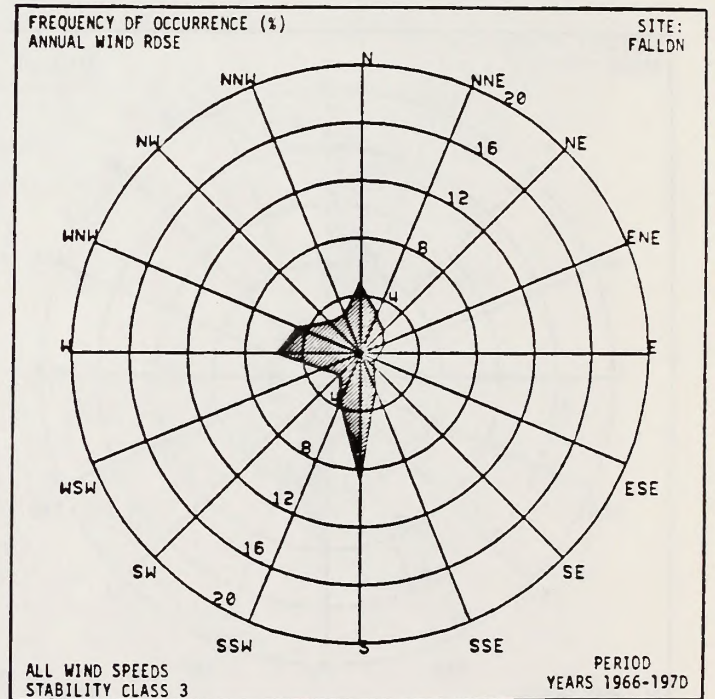
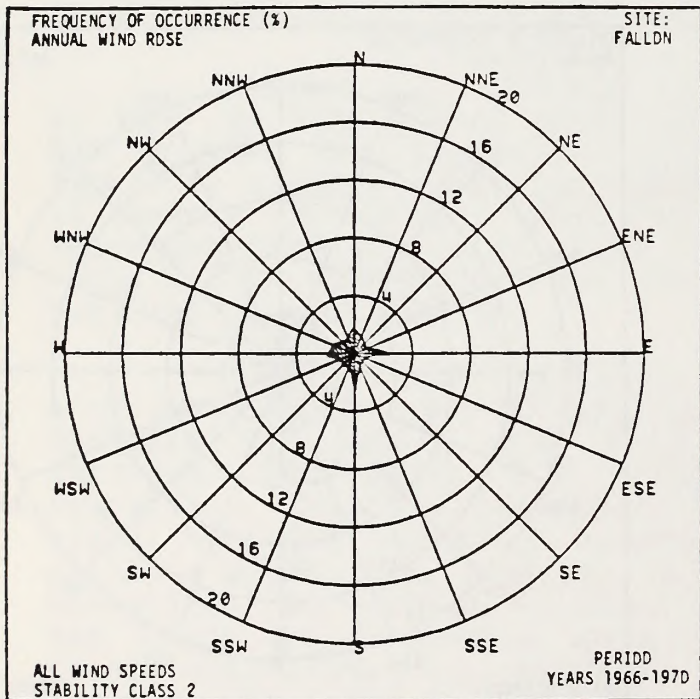
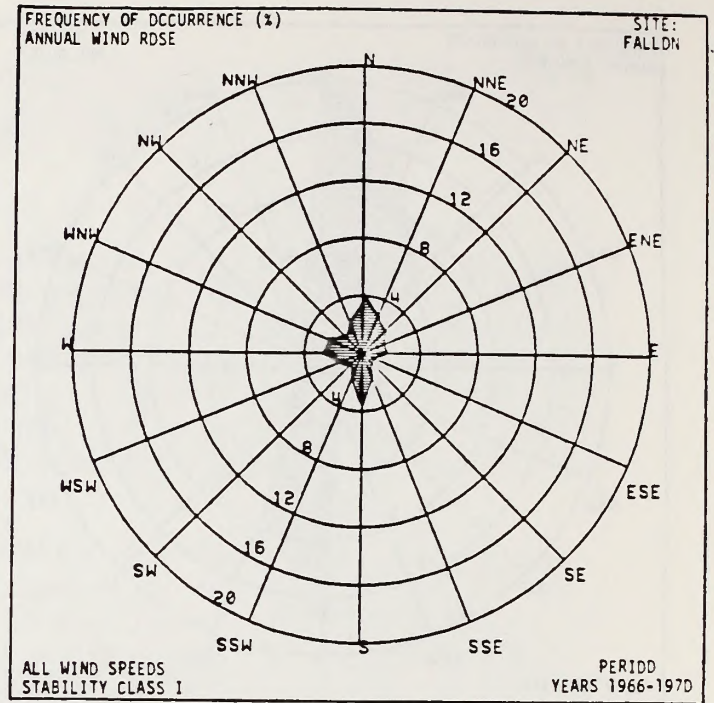
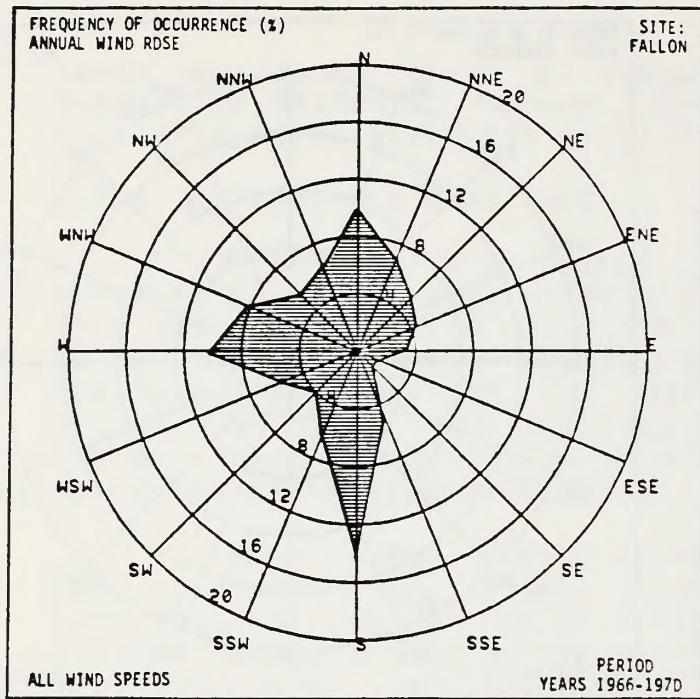

Figure 4.5-8
Stability Wind Roses for Fallon

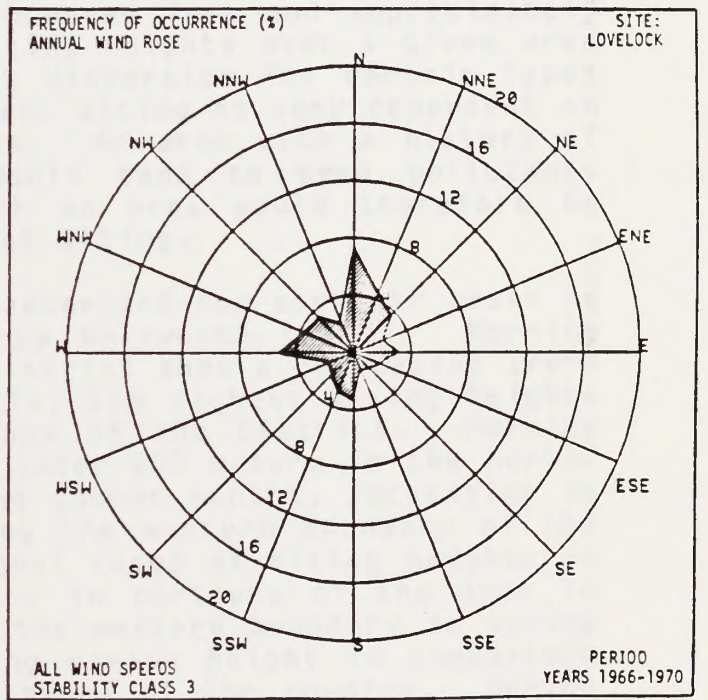
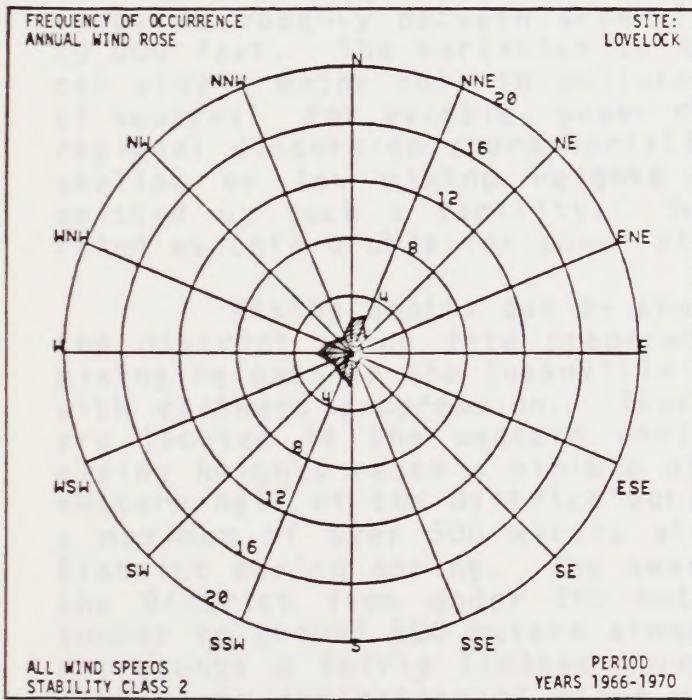
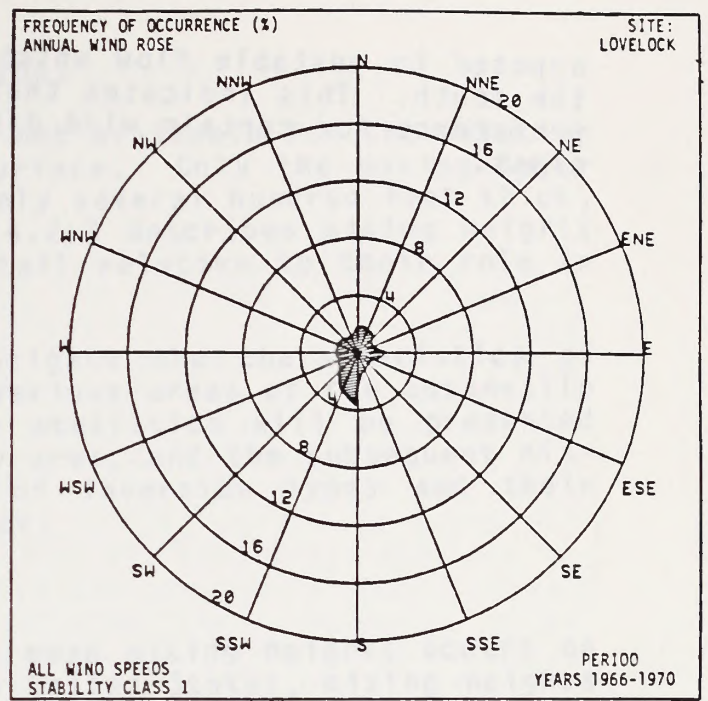
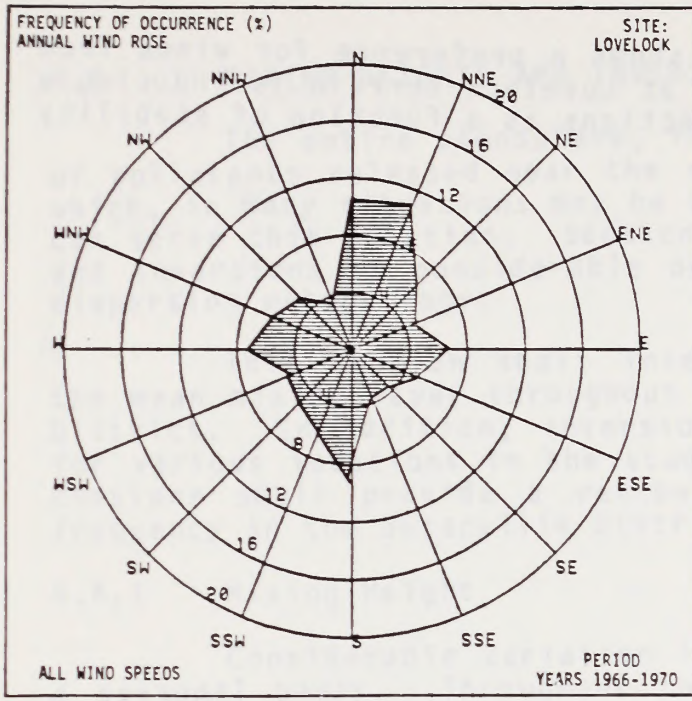

Figure 4.5-9
Stability Wind Roses for Lovelock

opposed to unstable flow which shows a preference for winds from the south. This indicates that at Lovelock terrain is inducing a preference for certain wind directions as a function of stability class.



4.6 MIXING HEIGHTS AND INVERSIONS

The entire atmosphere, is not available for the dilution of pollutants released near the surface. Only the mixing layer which, in many situations may be only several hundred feet thick, can serve this function. Section 4.2.3 describes mixing heights and inversions in considerable detail relative to their role in dispersion meteorology.

This section shall investigate the characteristics of the mean mixing layer throughout various areas of the Susanville District. In addition, inversion statistics will be presented for various locations in the study area, and the subsequent discussions shall provide a review of inversion types and their frequency in the Susanville District.

4.6.1 Mixing Height

Considerable variation in mean mixing heights occurs on a seasonal basis. Throughout the United States, mixing heights vary from several hundred feet on winter mornings to well over 13,000 feet on summer afternoons. In California, the mean annual range is roughly between several hundred feet and approximately 10,000 feet. The variation in mixing heights over a given area can play a major role in pollutant dispersion for certain types of sources. For example, power plant siting is very dependent on regional dispersion characteristics. An area with a history of shallow or low mixing heights would tend to trap pollutants emitted by such a facility. Such an area would therefore be rated as unfavorable for power plant siting.

Mixing depths can be characterized for each air basin in the district using data prepared by Holzworth (1972). Morning mixing heights in the Susanville District show a decreasing trend with eastward progression. That is, the highest mixing heights are located in the western portions of the District. Morning mixing heights reach a minimum of under 200 meters in the north-eastern half of the District during summer months, increasing to a maximum of over 500 meters along the western boundary of the District during spring. The seasonal range of mixing heights in the District from under 200 meters in portions of the area in summer to around 500 meters along the western boundary in spring represents a fairly limited morning mixing height in comparison with those indicative of other portions of the country. During the afternoons, the trends observed during the morning hours are reversed. In this case, mixing heights now begin to increase with eastward progression through the District. This reflects the effects of surface heating particularly during the warmer season months in areas to the east of the Sierra Nevada and Cascade Ranges. Afternoon mixing heights are lowest in the winter, being approximately 1000 meters along the western edge of the Susanville District, and reaching a maximum value of over 3000 meters in the Nevada portion of the District during summer. There is a steep gradient of mixing height, that is, change of

mixing height as a function of travel distance, during summer and autumn afternoons. In the summer, values range from around 2400 meters in the Sierra Nevada and Cascades to over 3200 meters in portions of Nevada.

The CARB (1974) has conducted upper air observations for winds and temperatures aloft at Sacramento, Red Bluff, Salinas, Fresno, Ukiah, Thermal and Riverside. The length of the data base presented in this report is less than three years in every case. The Sacramento and Red Bluff data provide additional information relative to mixing height characteristics in the Susanville District. Figures 4.6-1 and 4.6-2 provide a comparison of the mean spring morning mixing heights as defined using CARB and Holzworth data, respectively. The major difference exhibited by Figures 4.6-1 and 4.6-2 is the latitudinal alignment of the ARB isopleths in Northern California as opposed to the longitudinal alignment depicted by Holzworth. The ARB data also shows somewhat lower morning mixing heights along the southwestern border of the Susanville District as opposed to data presented by Holzworth. However, the ARB data, as well as the Holzworth data, are based upon information available from stations outside the confines of the Susanville District and for this reason either set of data should be used judiciously.

The CARB data does provide some interesting highlights relative to morning mixing heights at Sacramento and Red Bluff which may shed some light on conditions in portions of the Susanville District:

- (1) The lowest average mixing heights observed as part of the CARB monitoring program included data available from Red Bluff and Sacramento during the summer season.
- (2) Mixing heights were rather high at these stations during the winter months.
- (3) During other seasons, mixing heights at these locations are unremarkable.

The data indicate that the maritime influence of the seabreeze during summer has the effect of limiting mixing heights at these inland valley stations. However, the presence of the Cascade and Sierra Nevada Ranges will limit the influence of this regime in the Susanville District during summer and these trends may not be indicative of conditions in the District. During winter, however, the excellent mixing heights at Red Bluff and Sacramento are indicative of the greatly improved ventilation observed throughout much of Northern California during this season. These data are felt to be indicative of trends observed in the area for the winter months.

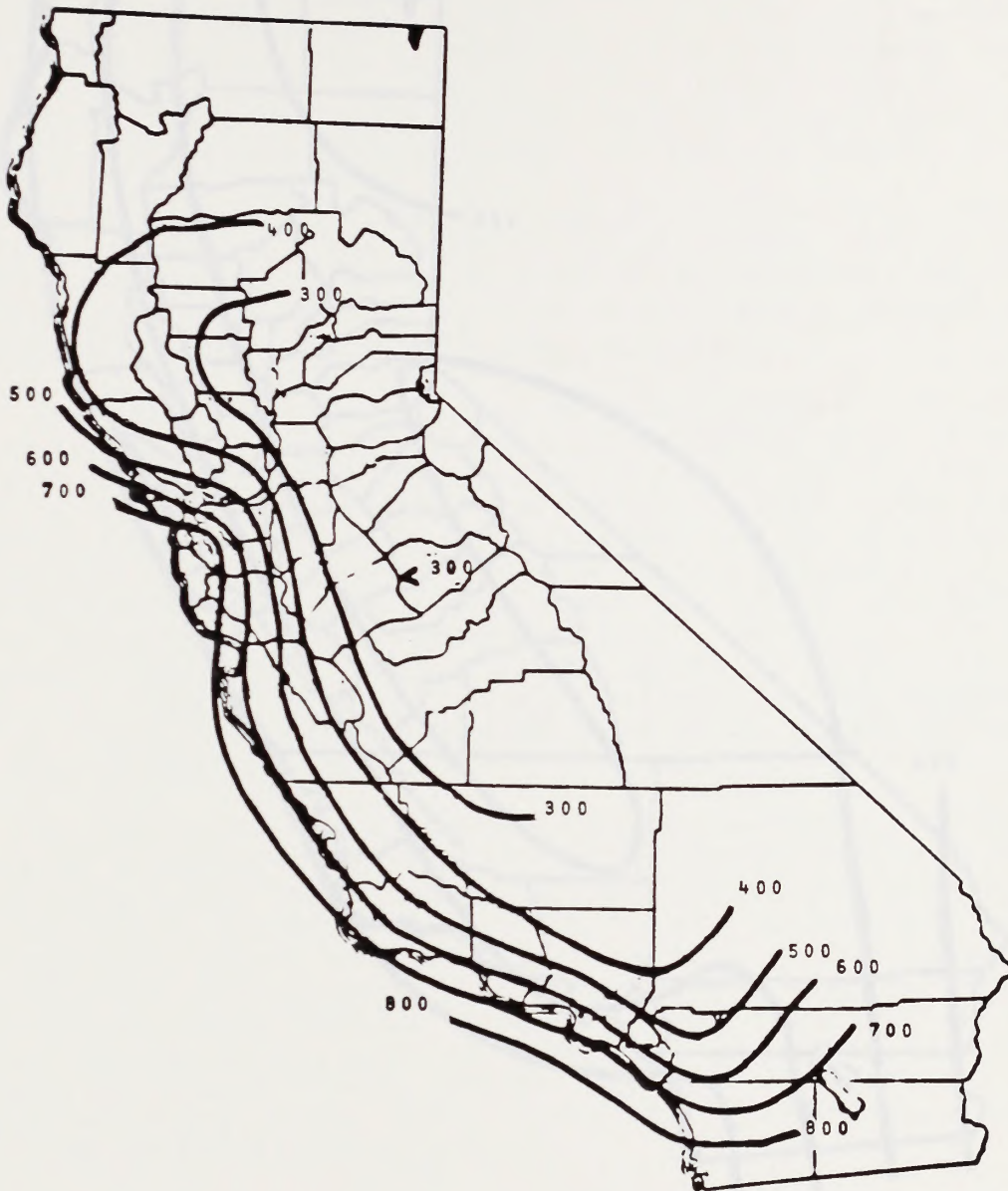

Figure 4.6-1
 Isopleths of Mean Spring Morning
 Mixing Heights (m) (with ARB Data)

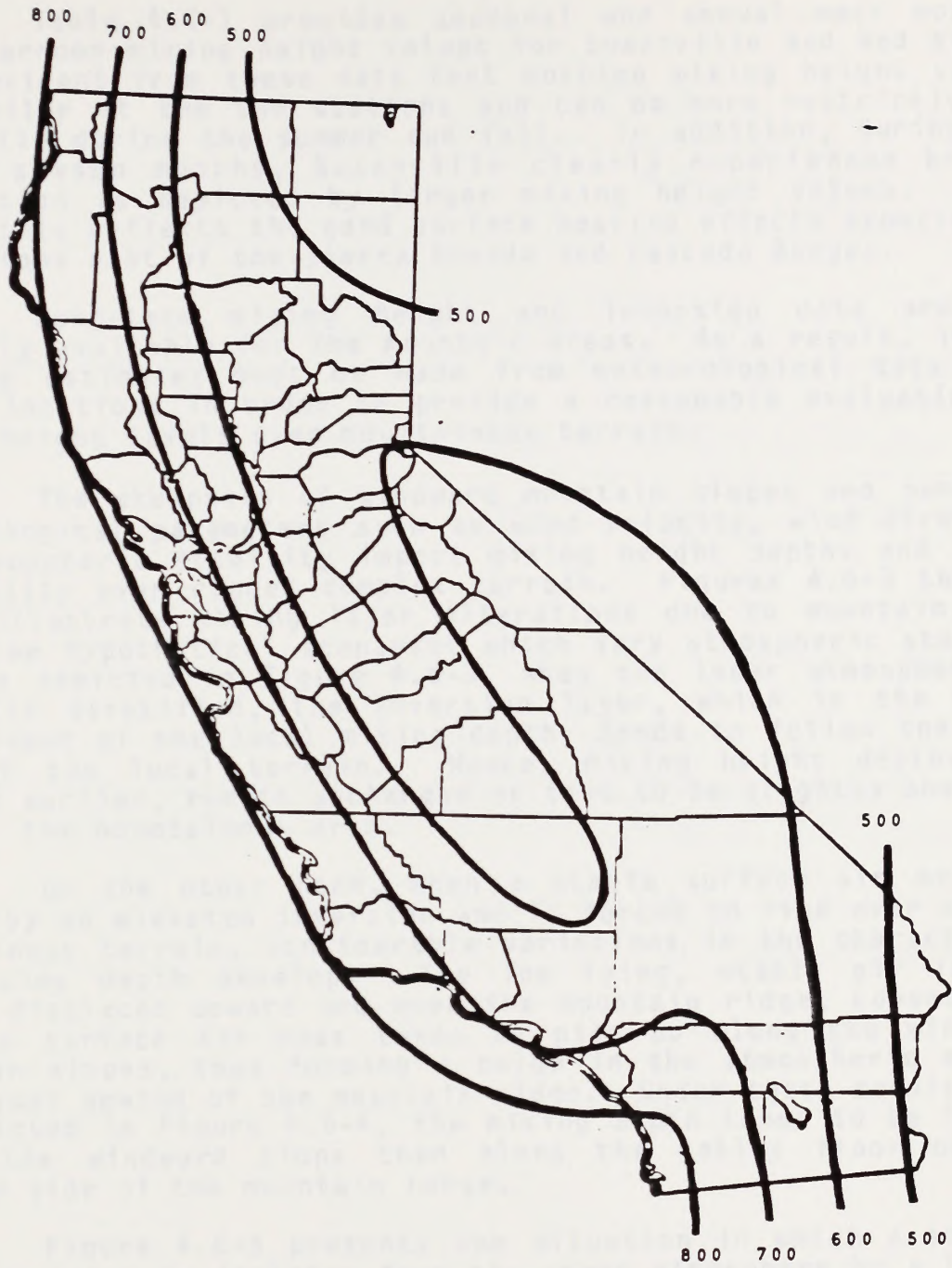

Figure 4.6-2
Isopleths of Mean Spring Morning
Mixing Heights (m) (from Holzworth)

Table 4.6-1 provides seasonal and annual mean morning and afternoon mixing height values for Susanville and Red Bluff. It is evident from these data that morning mixing height values are similar at the two stations and can be more restrictive at Susanville during the summer and fall. In addition, during the warmer season months, Susanville clearly experiences better ventilation as depicted by larger mixing height values. Once again, this reflects the good surface heating effects experienced at stations east of the Sierra Nevada and Cascade Ranges.

Long-term mixing height and inversion data are not currently available for the mountain areas. As a result, interpolative estimates must be made from meteorological data from nearby locations in order to provide a reasonable evaluation of mixing height levels over mountainous terrain.

The steepness of windward mountain slopes and numerous meteorological parameters such as wind velocity, wind direction and atmospheric stability impact mixing height depths and their variability over rugged complex terrain. Figures 4.6-3 through 4.6-5 illustrate mixing layer alterations due to mountain flow for three hypothetical scenarios which vary atmospheric stability. As depicted in Figure 4.6-3, when the lower atmosphere is neutrally stratified, the inversion layer, which is the major determinant of the local mixing depth, tends to follow the contour of the local terrain. Hence, mixing height depths, as defined earlier, remain unchanged or tend to be slightly shallower over the mountainous area.

On the other hand, when a stable surface air mass is capped by an elevated inversion and is forced to rise over abrupt mountainous terrain, considerable variations in the characteristic mixing depth develop. The low lying, stable air is not easily displaced upward and over the mountain ridge; consequently, the surface air mass tends to pile up along the windward mountain slopes, thus forming a bulge in the atmospheric mixing layer just upwind of the mountain ridge. Under these conditions, as depicted in Figure 4.6-4, the mixing depth tends to be larger along the windward slope than along the valley floor or the leeward side of the mountain range.

Figure 4.6-5 presents the situation in which a surface unstable layer is isolated from the upper atmosphere by a lifted inversion. As flow moves over rugged terrain, dramatic changes in the mixing layer can occur. Basically, the low lying, unstable air is forced to ascend into and through the inhibiting inversion layer as surface air flow is swept up the steep western slopes of the Sierra Nevada. This forced convective activity sometimes has the potential to completely wipe out the local inversion layer (or considerably weaken the stable layers) thus promoting considerable mixing of the lower lying air masses. Under such conditions, considerable cloudiness can develop and, at times, much precipitation. This is indicative of summer season conditions resulting in convective thundershower activity.

Table 4.6-1
 Mean Morning and Afternoon Values of
 Mixing Height (Meters)* in the Susanville District

	Morning/Afternoon				
	Winter	Spring	Summer	Fall	Annual
Susanville ¹	$\frac{400}{1000}$	$\frac{520}{2000}$	$\frac{220}{2700}$	$\frac{300}{1800}$	$\frac{360}{1875}$
Red Bluff ^{1,2}	$\frac{405}{940}$	$\frac{398}{1950}$	$\frac{309}{1900}$	$\frac{395}{1700}$	$\frac{377}{1623}$

* 1 meter = 3.28 feet

1. Mixing heights determined from interpolation of seasonal mixing height analysis from Holzworth's "Mixing Heights, Wind Speeds, and Potential for Urban Air Pollution Throughout the Contiguous United States."
2. Morning mixing heights based on Air Resources Board data covering a period from 1971-1974.

E-3

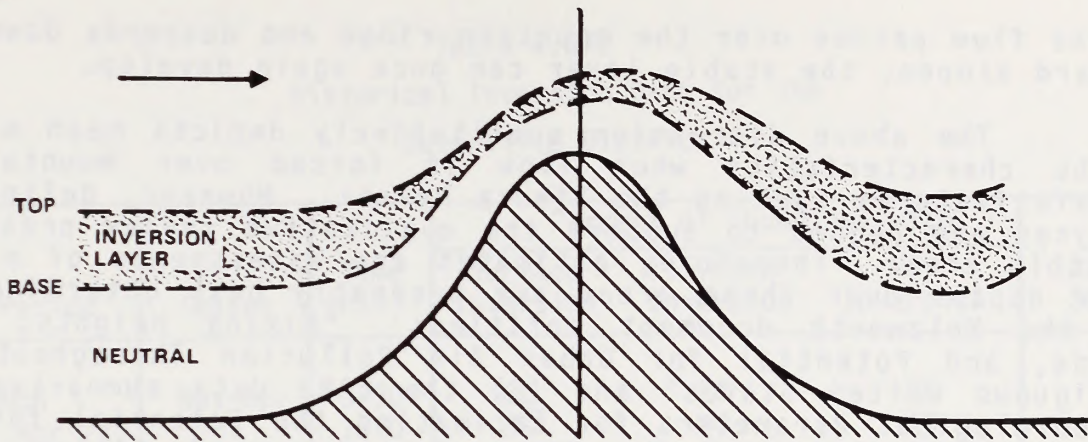

Figure 4.6-3
Depth of the Mixing Layer in Mountainous Terrain with Neutral Flow

E-4

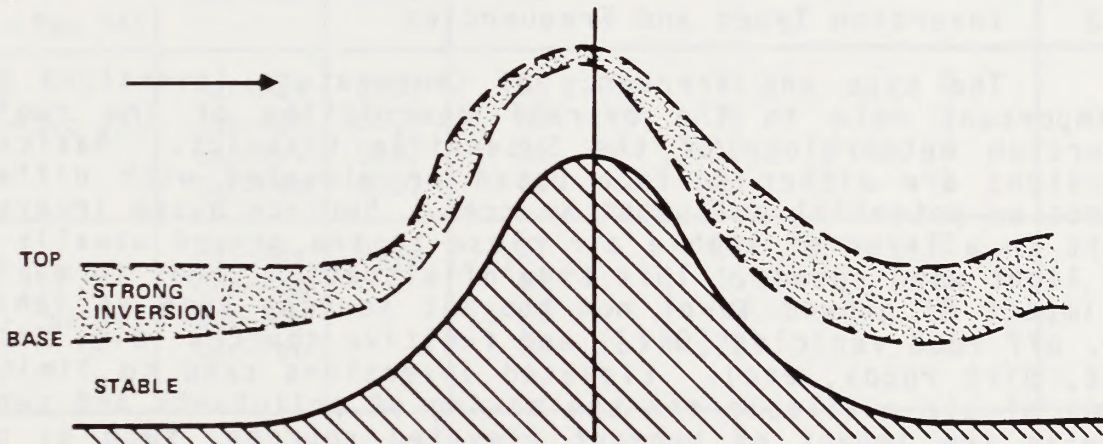

Figure 4.6-4
Depth of the Mixing Layer in Mountainous Terrain with Stable Flow

E-5

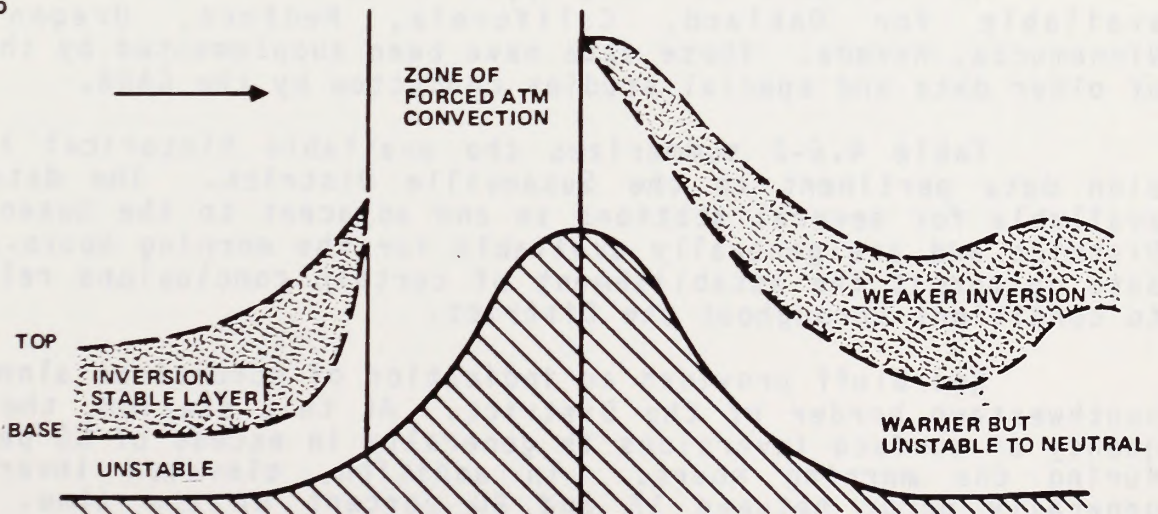

Figure 4.6-5
Depth of the Mixing Layer in Mountainous Terrain with Unstable Flow

As the flow passes over the mountain ridge and descends down the leeward slopes, the stable layer can once again develop.

The above discussion qualitatively depicts mean mixing height characteristics when flow is forced over mountainous terrain features such as the Sierra Nevada. However, definitive analyses are needed to support the qualitative review presented for this area. Therefore, estimates and assessments of mixing layer depths over these areas are presently best determined by (1) the Holzworth document entitled: "Mixing Heights, Wind Speeds, and Potential for Urban Air Pollution Throughout the Contiguous United States" and (2) the CARB data summarized in "Meteorological Parameters for Estimating the Potential for Air Pollution in California." Seasonal and annual mixing depth contour maps provided by the Holzworth publication are depicted in Appendix C. These figures also present an excellent means for comparing California mixing depth characteristics with other areas of the United States.

4.6.2 Inversion Types and Frequencies

The type and frequency of temperature inversions plays an important role in the overall description of the regional dispersion meteorology of the Susanville District. Basically, inversions are either surface based or elevated with differing impacts on potential pollutant sources. Surface based inversions result in a layer of stable air close to the ground usually with very light wind speeds. This type of situation tends to maximize the impact of ground level non-buoyant sources such as vehicles (e.g. off road vehicles [ORV]) and fugitive sources (e.g. storage tanks, dirt roads, etc). Elevated inversions tend to limit the volume of air available for the mixing of pollutants and tend to maximize the impact of buoyant elevated sources, such as power facilities, refineries, etc. The following paragraphs provide a review of the type and frequency of inversions experienced in the Susanville District.

As indicated earlier, upper air data are only routinely available for Oakland, California, Medford, Oregon and Winnemucca, Nevada. These data have been supplemented by the use of older data and special studies conducted by the CARB.

Table 4.6-2 summarizes the available historical inversion data pertinent to the Susanville District. The data are available for several stations in and adjacent to the Susanville District and are generally available for the morning hours. The data do permit the establishment of certain conclusions relative to conditions throughout the District.

Red Bluff provides an indication of conditions along the southwestern border of the District. At this station, the frequency of surface inversions is generally in excess of 80 percent during the morning hours. In addition, elevated inversions generally occur between 15 and 20 percent of the time. The

Table 4.6-2
Historical Inversion Data for the
Susanville District

Location/Period	Season	Time (PST)	Percent of Soundings with			Total Number of Soundings
			Surface Inversion	Elevated Inversion	No Inversion	
LAKE ALMANOR (Nov 71 - Apr 72)	Nov-Apr	0730	61	24	16	46
		1530	36	24	40	42
		2330	71	9	20	35
ALTURAS (May-Jun 72)	May-Jun	0400	100	0	0	40
MONTAGUE (Dec 73 - Feb 74)	Dec-Feb	0645	100	0	0	40
RED BLUFF (Oct 71 - Dec 73)	Mar-May	0500	85	13	2	177
	Jun-Aug	0500	83	16	1	122
	Sep-Nov	0500	81	16	3	203
	Dec-Feb	0500	86	13	1	152
UKIAH (Oct-Nov 71) (Nov 72 - Jun 74)	May-May	0500	87	11	2	173
	Jun-Aug		84	16	0	119
	Sep-Nov		89	9	2	129
	Dec-Feb		80	20	0	131

frequency of cases where no inversions were observed was very low.

Lake Almanor provides an indication of conditions along the slopes of the Sierra Nevada which comprises the western boundary of the southern portion of the District. At this location, the frequency of surface inversions during the morning hours was just over 60 percent with elevated inversions occurring 25 percent of the time. No inversions were observed 15 percent of the time which is indicative of conditions in more mountainous terrain where inversions occur with somewhat less frequency than at lowland valley stations.

Data are also available from Montague and Medford. These give an indication of conditions in the mountainous northwestern portion of the Susanville District. Once again, Medford shows a frequency of surface inversions of nearly 70 percent during the morning hours with elevated inversions accounting for another 6 percent. Finally, 25 percent of the time no inversions are present at this station. The available data from Montague are very limited but show a 100 percent frequency of occurrence of surface inversions during the morning hours. Montague is a lowland valley station and the pooling of cold air as a result of nocturnal drainage flow results in the high frequency of surface inversions observed at this station during the early morning hours.

Finally, data are available for Alturas which is located in the Susanville District. Once again, the limited amount of data available for this station indicates a high frequency of morning surface inversions indicative of conditions in an inland or valley location. The Alturas data, while limited, are felt to be indicative of conditions to the east of the Cascade and Sierra Nevada Ranges which comprises the bulk of the District.

4.7 TYPICAL AND WORST-CASE CONDITIONS

Previous sections have thoroughly examined and discussed the factors affecting the atmospheric dispersion characteristics of the Susanville District. This permits the identification of typical and worst-case conditions for a variety of typical sources found in the Susanville District. This analysis will provide a basis for determining an initial evaluation of the typical and worst-case impact of various land use alternatives using simplistic modeling techniques as described in Section 4.9.

4.7.1 Typical Dispersion Conditions

Typical dispersion conditions define the most commonly occurring combination of the key dispersion parameters, i.e., wind speed, wind direction and atmospheric stability class. This information is useful particularly in first cut or screening level of effort air quality modeling analyses as described in Section 4.9. In such cases, it is desirable to have a rough estimate of the most commonly occurring dispersion conditions in order to get an indication of the typical impact of an existing or proposed source.

Table 4.7-1 provides a description of the most frequently occurring dispersion parameters for sites near the Susanville District for which the necessary data are available. These include Sacramento, Red Bluff, Fallon and Lovelock. The data in Table 4.7-1 provide the most frequently occurring wind direction, wind speed and stability category information suitable for characterizing dispersion meteorological conditions. As such, it is suitable for use in screening level of effort or simplistic modeling calculations to provide a preliminary estimate of existing or proposed pollutant source impacts. The reader is cautioned, however, that dispersion analyses require site specific meteorological data and a more thorough review than that provided by the type of information contained in the table.

4.7.2 Worst-Case Dispersion Conditions

Worst-case dispersion conditions are used by dispersion meteorologists in a screening level of effort to determine the probable maximum impact of an existing or proposed facility. The results of such a review provide an indication as to whether more detailed and sophisticated analyses are required. Once again, as with typical conditions, the worst-case can be defined in terms of the primary dispersion parameters, atmospheric stability class, wind speed and wind direction. The reader is again cautioned in the use of the following information as site-specific data and more detailed analyses are desirable to accurately gage pollutant impact.

In an effort to identify the historical worst-case conditions occurring in California, it was necessary to create a table of five pollutant sources with typical exit characteris-

Table 4.7-1
 Description of Typical Meteorological Conditions⁽¹⁾
 Throughout the Susanville District

Station	Direction	Wind Speed (MPH)	Stability Category ⁽²⁾
Sacramento	SW	7.5	3
Red Bluff	N	8.9	3
Fallon	S	5.2	3
Lovelock	NNE	6.0	3

(1) As defined by the most frequently occurring value on an annual basis - parameters are not interrelated, i.e., the indicated wind speed is for the total data base and is not the average for the most frequently occurring wind direction.

(2) 1 - Unstable (Pasquill Classes A, B, C)
 2 - Neutral (Pasquill Class D)
 3 - Stable (Pasquill Classes E, F, G)

tics. Table 5.4-1 summarizes typical emission characteristics for fugitive dust, automobiles, oil recovery operations, oil refineries and large power plants. In addition, a traditional worst-case scenario often used by dispersion meteorologists is described. Although the primary pollutants generated from each of these sources may vary, the short-term characteristics of these gases and/or particulates in the atmosphere may be assumed to be highly similar. The five sources listed in Table 5.4-1 represent ground level, non-buoyant; ground level, slightly buoyant; low-level, buoyant; intermediate-level, buoyant; and elevated, buoyant emissions, respectively. Table 4.7-2 lists the worst-case dispersion conditions for each of these sources.

Table 4.7-3 provides the annual frequency of the selected worst-case scenarios for several stations throughout the Susanville District. The table indicates that the selected scenarios for the cross section of sources occur with considerable variability across the area. In addition, the frequency of the scenario selected for one type of source may occur with a substantially different frequency than that selected for another source. This highlights the importance of attaching the probability of occurrence to the selected worst-case meteorological condition for the source in question. The difference in measurement technique is also evident in the data collected at the PGE sites, where the temperature difference technique is used to measure atmospheric stability. These data show a substantially higher frequency of the unstable conditions in a comparison with those observed at the first order NWS stations. All of this highlights the care which must be used in providing an accurate analysis of the probable impact of the source, and the need to involve professional dispersion meteorologists in such programs.

Mixing height, an important parameter in the definition of both typical and worst-case conditions has not been included in the above analysis. This is often difficult to do as real time mixing height data are not generally available concurrently with surface wind speed, wind direction and atmospheric stability class data to provide for meaningful analysis. However, typical mixing heights can be obtained from the data presented in Section 4.6.1, while historical worst-case mixing heights are discussed by Holzworth in his publication "Meteorological Episodes of Slowest Dilution in Contiguous United States".

Table 4.7-2
Worst-Case Dispersion Conditions
For a Cross-Section of Typical Sources

Source ⁽¹⁾	Wind Speed (MPH)	Stability Class (Pasquill Class) ⁽²⁾
Fugitive Dust	1.1	D
Automobiles	1.1	D
Oil Recovery Operations	26.8	C
Oil Refinery	6.7	A
Power Plant	6.7	A
Traditional ⁽³⁾ Worst-Case	2.3	F

1. Reference Table 5.4-1 for a description of the exit characteristics for the sources listed below.
2. Section 4.5 provides a complete discussion of atmospheric stability.
3. In theoretical or "back of the envelope" calculations, this case is often used by meteorologists to describe worst-case conditions.

Table 4.7-3
Annual Frequency (%) of Worst-Case Meteorological Conditions⁽¹⁾
Throughout the Susanville District

Stability Class and Wind Speed (MPH)	Sacramento	Red Bluff	Fallon	Lovelock
F and 2.3	13.9	5.8	32.8	23.8
D and 1.1	7.4	7.4	2.0	2.6
C and 26.8	Neg.*	Neg.*	Neg.*	Neg.*
A and 6.7	0.5	0.5	1.5	0.9

(1) As defined for the sources indicated in Table 4.7-2 and described in Table 5.4-1.

* Neg. = Negligible but non-zero.

4.8 AIR BASIN ANALYSIS

The State of California encompasses an extremely large land area which exhibits a wide variety of geographic and topographic features (see Section 2). As air masses migrate into California, the prevailing winds and dispersion characteristics are greatly influenced by terrain. The degree and nature of the influence can be characterized for geographically and/or meteorologically homogeneous areas. Such zones of similar atmospheric dispersion characteristics can be identified as air basins. Figure 4.8-1 provides the results of an air basin analysis for California while Figure 4.8-2 presents a summary map of the air basins located within the Susanville District of California. The figures represent an original analysis independent of political boundaries and are, therefore, slightly different than the CARB air basin map for the State. The latter figure is also provided as Overlay F.

Air basins provide a means of isolating particular areas of the state that generally exhibit similar atmospheric flow, ventilation mechanisms and dispersion potential. As presented in the figure, these areas include:

- o North Coastal Air Basin
- o North Coastal Mountain Air Basin
- o North East Hills Air Basin
- o Mountain Area Air Basin
- o Sacramento Valley Air Basin
- o San Joaquin Valley Air Basin
- o San Francisco Bay Area Air Basin
- o Central Coast Air Basin
- o Central Coastal Mountains Air Basin
- o South Coastal Air Basin
- o South Coastal Mountains Air Basin
- o Great Basin Valley Air Basin
- o South East Desert Air Basin

The development and use of an air basin classification scheme requires one to visualize the atmosphere as a moving fluid washing over mountain ridges and spilling into valleys and through canyon areas. As indicated above, physically and meteorologically homogeneous areas can be then identified and used in dispersion analyses. Regional terrain characteristics generally establish the boundaries of such areas. Terrain features are dominant in establishing air basins as mountain ranges and valleys obstruct or alter regional flow and, hence, dispersion conditions. Figure 4.8-1 illustrates the importance of terrain features in defining meaningful air basins.

While air basins are characteristically defined by major regional terrain features, the climatological and dispersion meteorological conditions existing in the area in question also provide considerable information relative to the identification of homogeneous air basins. An area can be homogeneous from a

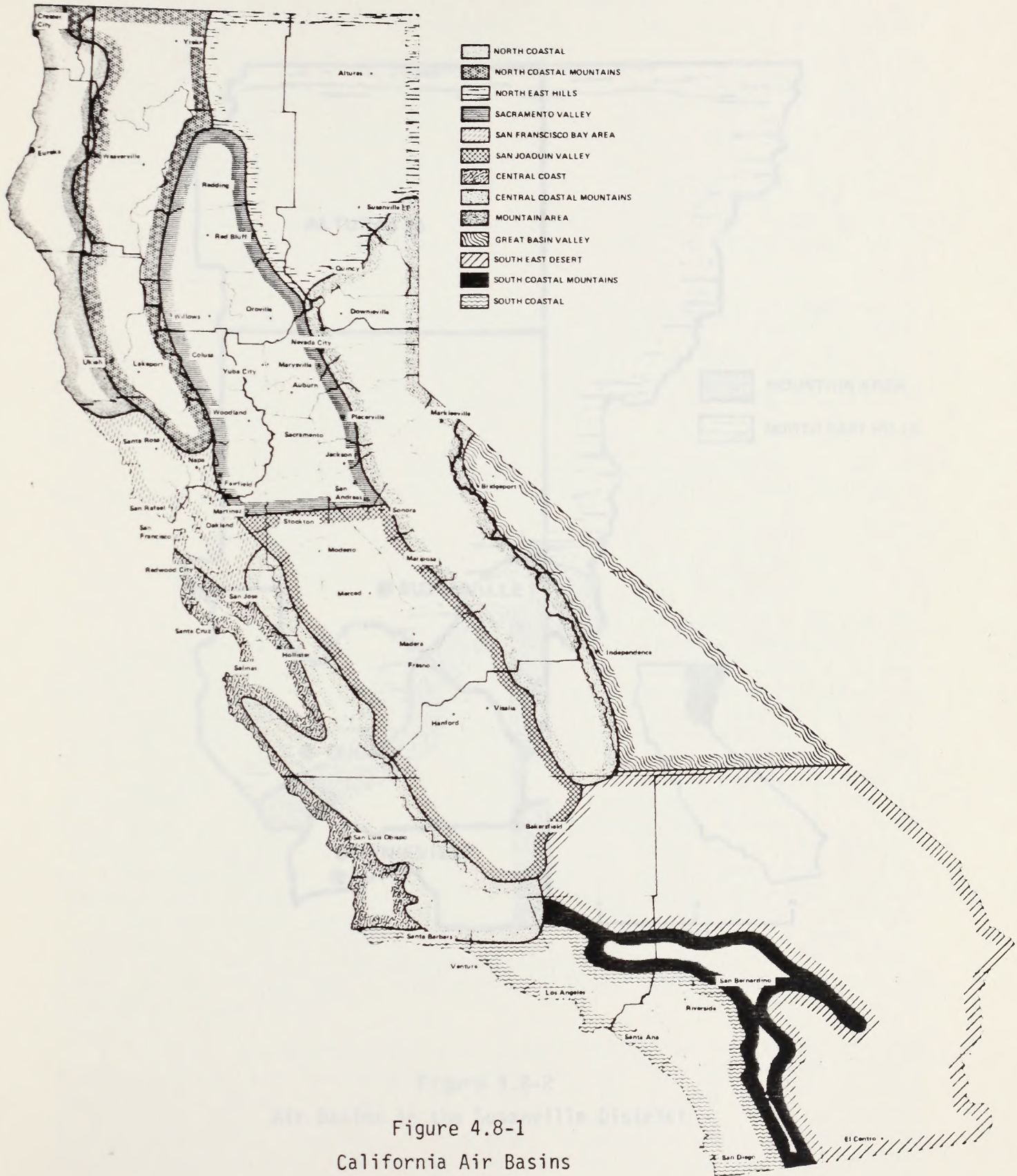

Figure 4.8-1
California Air Basins

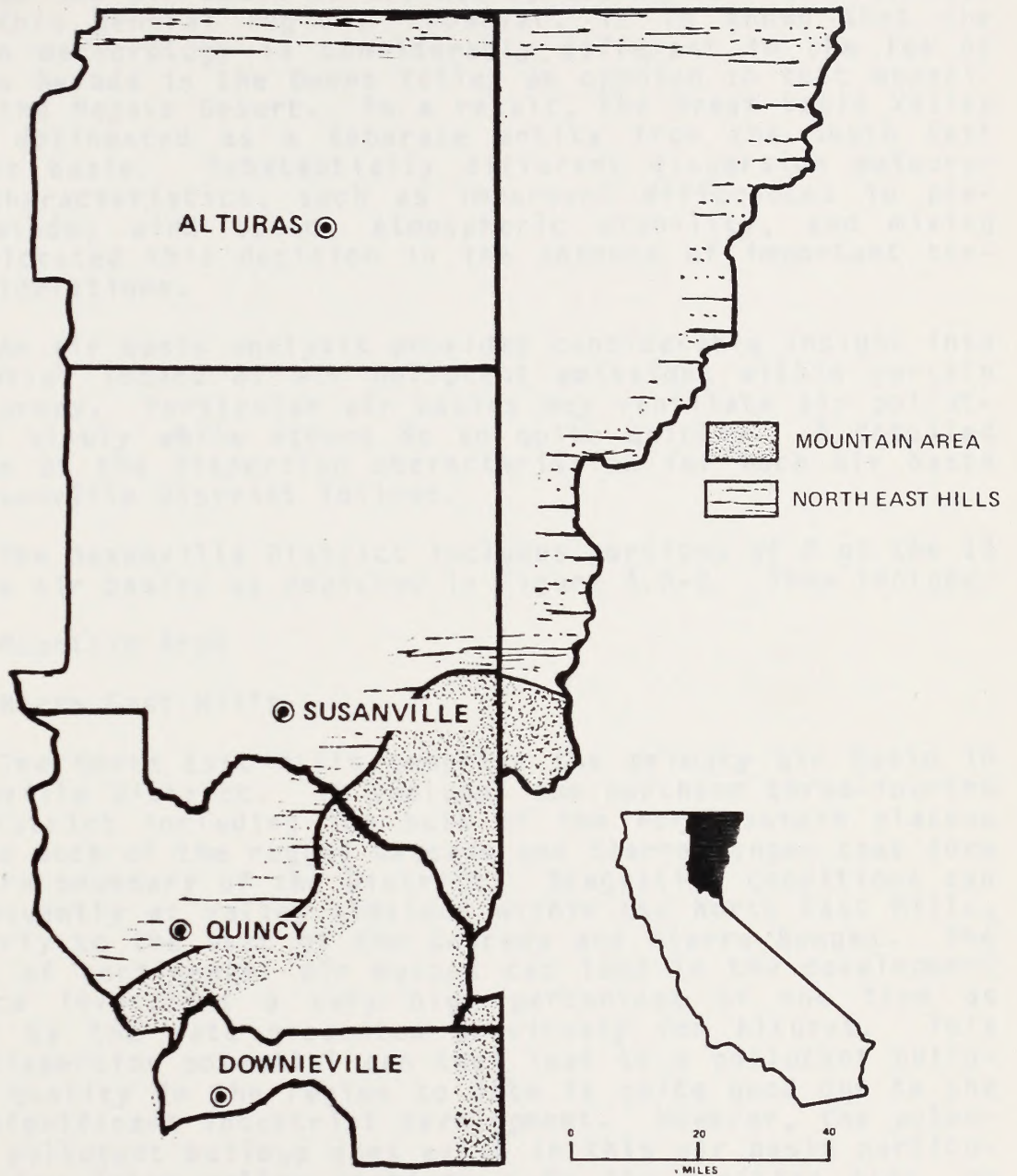

Figure 4.8-2
Air Basins in the Susanville District

terrain standpoint but may vary significantly in terms of the actual dispersion meteorology. For example, in California, a case could be made for including the Mojave Desert and Owens Valley into one air basin as defined by the terrain characteristics of this general region. However, it is known that the dispersion meteorology is considerably different in the lee of the Sierra Nevada in the Owens Valley as opposed to that experienced in the Mojave Desert. As a result, the Great Basin Valley has been delineated as a separate entity from the South East Desert air basin. Substantially different dispersion meteorological characteristics, such as important differences in prevailing winds, wind speed, atmospheric stability, and mixing heights dictated this decision in the absence of important terrain considerations.

An air basin analysis provides considerable insight into the potential impact of air pollutant emissions within certain regional areas. Particular air basins may ventilate air pollutants very slowly while others do so quite quickly. A detailed discussion of the dispersion characteristics for each air basin in the Susanville District follows.

The Susanville District includes portions of 2 of the 13 California air basins as depicted in Figure 4.8-2. They include:

- o Mountain Area
- o North East Hills

The North East Hills comprise the primary air basin in the Susanville District. It includes the northern three-fourths of the District including the bulk of the northeastern plateau region and much of the rugged Cascade and Sierra Ranges that form the western boundary of the District. Stagnating conditions can occur frequently at valley stations within the North East Hills, particularly to the east of the Cascade and Sierra Ranges. The influence of continental air masses can lead to the development of surface inversions a very high percentage of the time as indicated by the data presented previously for Alturas. This limited dispersion potential can then lead to a pollutant buildup. Air quality in the region to date is quite good due to the lack of significant industrial development. However, the potential for pollutant buildup does exist in this air basin particularly at low lying valley stations. On the positive side, no significant terrain blocks eastward movement and for this reason pollutant buildups would rapidly dissipate under normal west to east flow conditions.

The Mountain Area air basin includes portions of the Sierra Nevada and the southeastern one-quarter of the District. The Mountain Area air basin is comprised by rugged terrain particularly in the Sierra Nevada. Many locations in this air basin are higher than the mean elevated inversion levels generally experienced to the west over the Central Valley of California.

However, many minor air basins do exist in the mountain areas and some isolated areas are surrounded by towering mountains. In such areas, including Tahoe and Lake Almanor, dispersion of air contaminants can be greatly inhibited. On the other hand at mountain peaks and other well-exposed locations, the ventilation characteristics are generally excellent since the wind flow is basically uninhibited by surrounding physiographic features.

4.9 FIRE WEATHER

The primary purpose for the utilization of open burning is to quickly eliminate choking underbrush, for example, in the management of forested lands, or to dispose of waste vegetative growth in the management of agricultural areas. These goals must be accomplished while causing a minimum impact upon ambient air quality in the surrounding region. For this reason, it is desirable prescribed burns be fired as rapidly as safety and the objectives of the burn will permit in order to maximize the atmosphere's dispersive capabilities by getting the resulting smoke well above the surface layer.

Meteorology plays a very important role in the identification of proper periods during which to burn with a minimum impact on surrounding air quality. Burn versus no-burn days are forecasted daily by the CARB for each of the designated air basins in California. Forecasts for the following day are usually available by 1500 PST. If the issuance of a forecast is delayed, they are to be available by no later than 0745 PST on the day in question. The CARB uses some very basic criteria in making decisions relative to open burning in each of California's air basins. The forecasting criteria are designed to isolate those days on which the burning of large surface areas will have a minimum impact on local air quality, based upon the atmosphere's ability to disperse pollutants. Factors which impact this are the stability of the atmosphere, the presence of either surface or elevated inversions and the mean wind speed and wind direction. Previous sections have provided a review of the dispersion meteorology of the Susanville District and reference is made to that discussion for more details relative to these parameters.

The dispersion of smoke generated from open burning is restricted by such features as stable atmospheric conditions, an elevated inversion which restricts the volume of air available for mixing, as well as low wind speeds which result in little movement of the pollutants once they are emitted. These meteorological considerations work hand in hand with the nature of the local terrain. Areas which are in a valley or a bowl and are surrounded by important terrain features tend to trap emitted pollutants near the source particularly when restrictive meteorological conditions combine with such terrain effects. Accordingly, the CARB forecasting criteria include a review of the anticipated strength of the morning surface inversion, the relative stability of the atmosphere from the surface to roughly 3,000 feet, the wind speed at the expected plume height, as well as the probable wind direction. Burning is not permitted on days when wind speeds are light, the atmosphere is stable, strong surface or elevated inversions exist, or if wind directions will tend to blow smoke toward populated areas.

Section 6.5.2 will provide a review of the regulatory constraints involved in open outdoor burning including the acqui-

sition of permits. Once a permit is obtained, the basic decision whether or not to burn is based upon acquiring the burn/no-burn forecast from the CARB in Sacramento. In addition to this, local rules of thumb, from Section 5153 of the Forest Service Manual for the California Region, should be used as guidelines as to the proper management of the burn in terms of meteorological conditions. The following provides an example of typical considerations:

- o The wind direction at the probable plume height should be such that the plume will move away from Smoke Sensitive Areas (SSA) (i.e., heavily populated or high use areas susceptible to excessive accumulations of emissions into the air as a result of concentration of sources and climatological and topographic restraints on ventilation). The California Division of Forestry (CDF) has designated SSA's in California which should be subjected to minimum impact by any burn contemplated by BLM managers. Figure 4.9-1 provides a review of the location of such areas in the state. These regions include most of the populous areas of the state, as well as areas in rugged terrain subject to considerable recreational use.
- o Generally, low wind speeds should be avoided, particularly where SSA's may be impacted or residual smoke may be entrained into nighttime downslope flow. Low winds provide less dilution and slow plume transport.
- o Wind speeds should generally be greater than 15 miles per hour at the venting height to maximize dispersion.
- o Surface inversions should be avoided due to the potential for trapping the smoke near the surface. However, if the plume is carried above the inversion, the downward dispersion of contaminants will be inhibited by the surface based inversion.
- o If the burn will be less than 12 hours, it is beneficial to start in the morning as this will tend to maximize the buoyant effects associated with the burn. However, morning fires are not permitted if fire-weather indexes will rise above the safe level during the burn.
- o If the burn is to last more than 12 hours, it may be beneficial to start at night as this may minimize adverse smouldering effects, experienced following the burn. This is effective for higher elevation, heavy full burns, above the usual valley bottom inversion. More stable night air is compensated by the strong convective column phase of the burn.
- o Burning so that smoke rises into the base of a precipitating cloud system is advantageous from an air quality

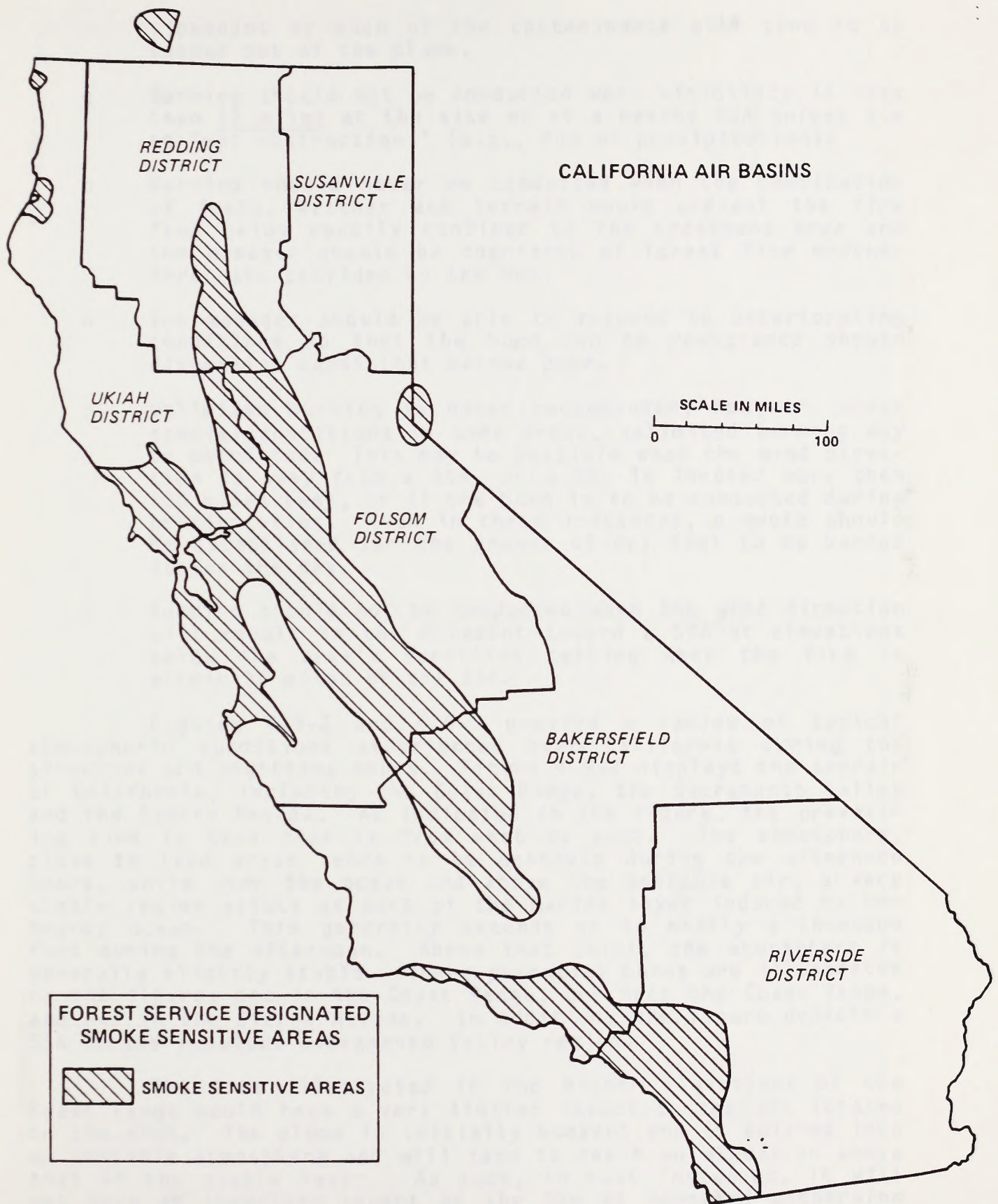

Figure 4.9-1

viewpoint as much of the contaminants will tend to be washed out of the plume.

- o Burning should not be conducted when visibility is less than 11 miles at the site or at a nearby SSA unless due to "wet obstructions" (e.g., fog or precipitation).
- o Burning should never be conducted when the combination of fuels, weather and terrain would prevent the fire from being readily confined to the treatment area and the manager should be cognizant of forest fire weather forecasts provided by the NWS.
- o The manager should be able to respond to deteriorating conditions so that the burn can be downgraded should dispersion conditions become poor.
- o Unlimited burning is never recommended; however, under special conditions in some areas, unlimited burning may be permitted. This may be possible when the wind direction is away from a SSA, or a SSA is located more than 100 miles away, or if the burn is to be conducted during precipitation. Even in these instances, a quota should be established for the amount of dry fuel to be burned during the day.
- o Burning should not be conducted when the wind direction will result in the movement toward a SSA at elevations below the area's specified ceiling when the fire is within 30 miles of the SSA.

Figures 4.9-2 and 4.9-3 provide a review of typical atmospheric conditions experienced over California during the afternoon and nighttime hours. Figure 4.9-2 displays the terrain of California, including the Coast Range, the Sacramento Valley and the Sierra Nevada. As indicated in the figure, the prevailing wind in this area is from west to east. The atmosphere, close to land areas tends to be unstable during the afternoon hours, while over the ocean and above the unstable air, a very stable regime exists as part of the marine layer induced by the nearby ocean. This generally extends up to nearly a thousand feet during the afternoon. Above that point, the atmosphere is generally slightly stable. Three potential burns are illustrated on the figure; one in the Coast Range, one near the Coast Range, and one in the Sierra Nevada. In addition, the figure depicts a SSA in the populous Sacramento Valley region.

The fire illustrated in the higher elevations of the Coast Range would have a very limited impact in the SSA located to the east. The plume is initially buoyant and is emitted into an unstable atmosphere and will tend to reach an elevation above that of the stable layer. As such, in most instances, it will not have an important impact on the SSA as downward dispersion will be inhibited. The burn illustrated in the lee of the Coast

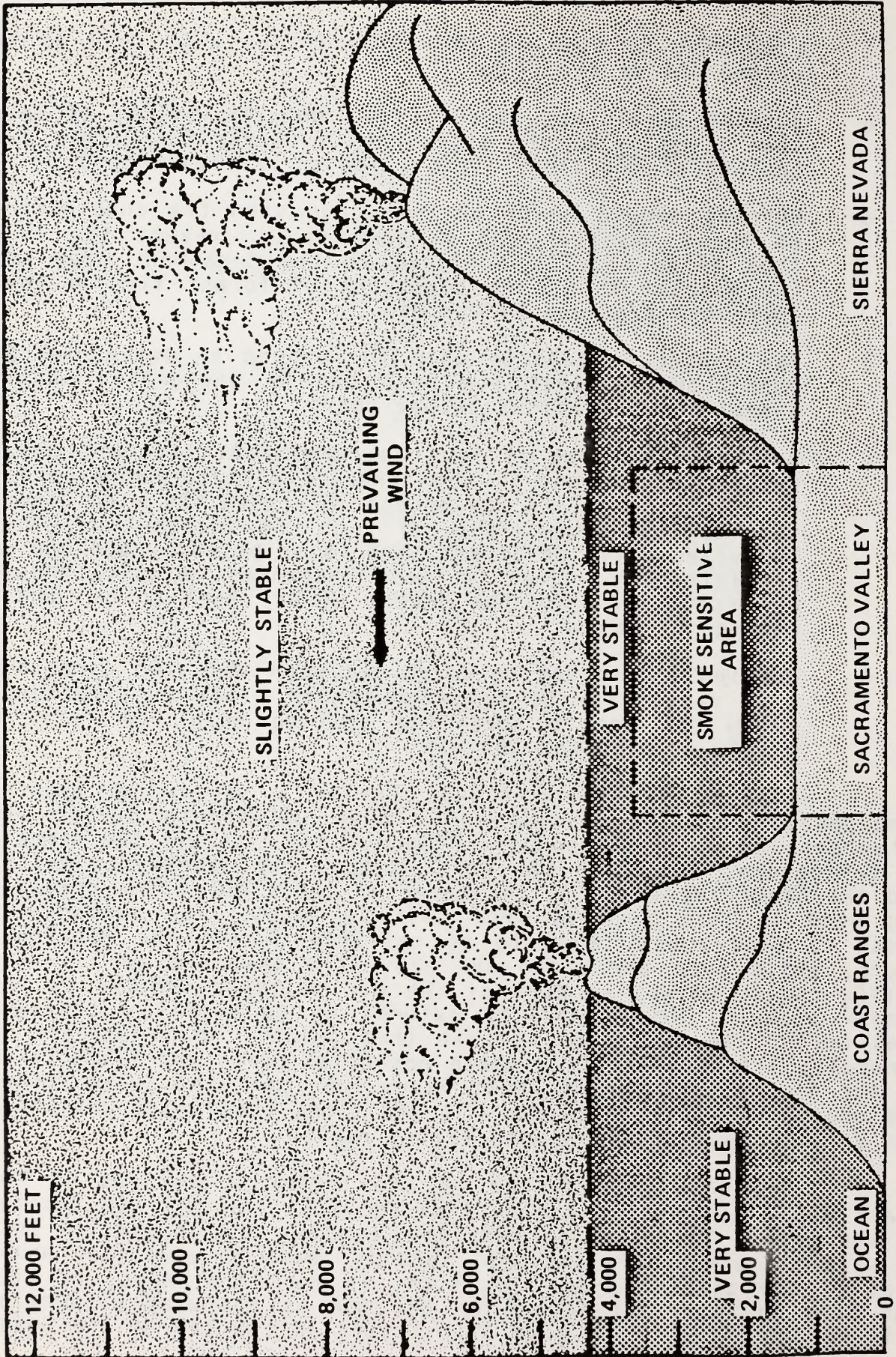

Figure 4.9-3
 Typical Nighttime Dispersion Conditions and the Impact on Burning

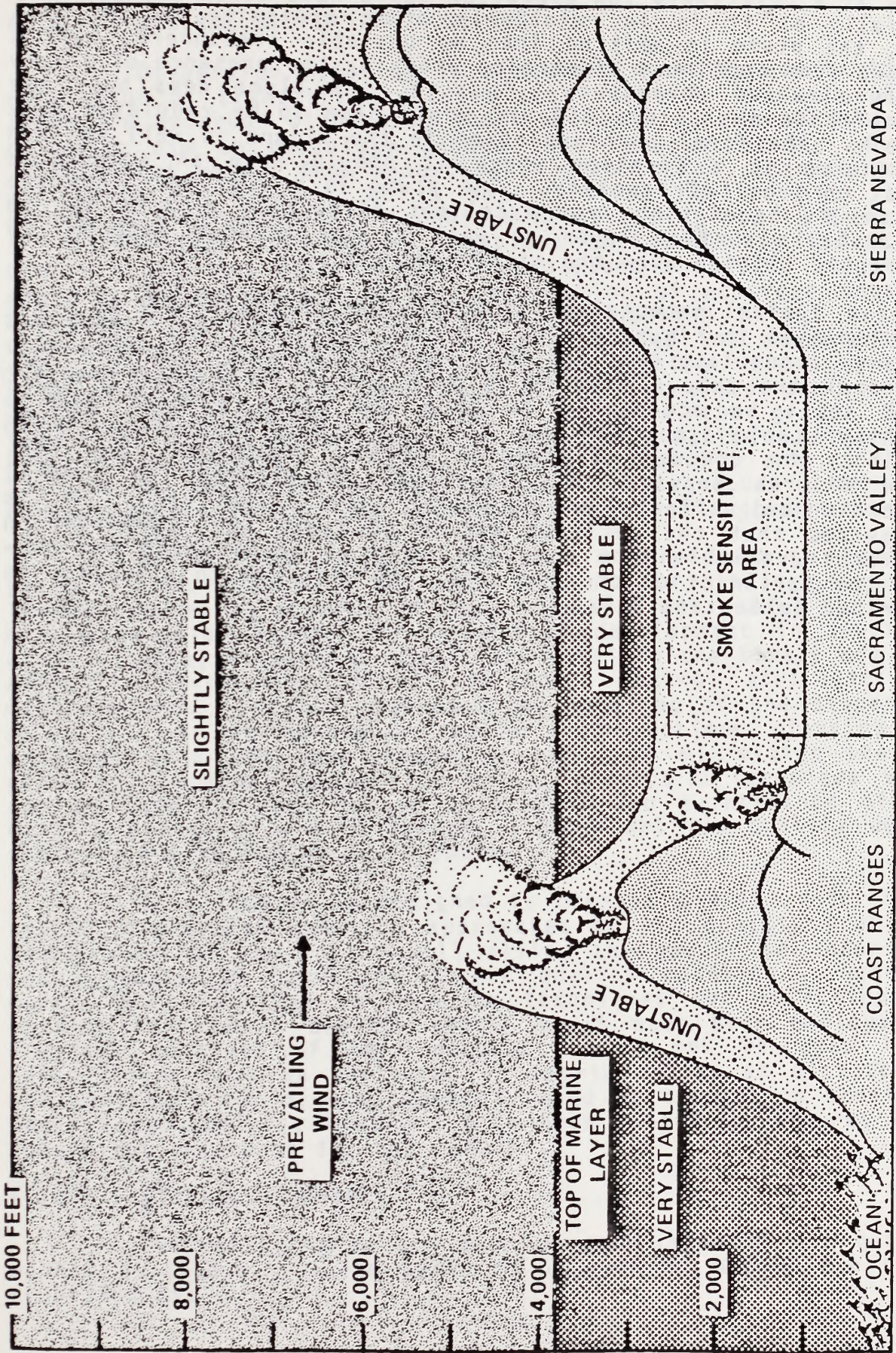

Figure 4.9-2

Typical Afternoon Dispersion Conditions and the Impact on Burning

Range at a relatively low elevation would have to be managed very carefully as it is in relatively close proximity to the SSA. Here, the plume is emitted into an unstable atmosphere, but is limited from continued dispersion aloft by the presence of a very stable elevated inversion. As such, the plume does have the potential to impact the SSA and would have to be regulated very closely. The final burn indicated in the figure is well up into the Sierra at a location where it should have an acceptable impact on local air quality. The plume is moving away from the SSA and is benefiting from excellent dispersion effects due to the unstable surface layer as well as the effects imparted by orographic lifting over the higher terrain.

Typical meteorological conditions in California at night are displayed in Figure 4.9-3. In this instance, very stable air tends to accumulate over the SSA, and burning would not be recommended in the zone. Burning at mountaintop locations, however, would still be acceptable as they are being emitted into a slightly stable atmosphere and the very stable layer below would prohibit the downward dispersion of the plume into the SSA. These figures provide only idealized descriptions of typical meteorological effects on potential burn situations. It is emphasized that the decision should be based upon burn/no-burn forecasts available from the CARB, even in areas which are outside the jurisdiction of regulatory agencies due to elevation as described in Section 6.5.2.

4.10 GENERAL DISPERSION MODELING

Dispersion modeling is a mathematical representation or simulation of transport processes that occur in the atmosphere. There are numerous dispersion modeling techniques available, all of which aim to calculate ground level concentrations of pollutants that result from industrial, agricultural, transportation and urban emissions. It is important to realize that there exists no single modeling technique capable of properly depicting all conceivable dispersion situations that occur in the atmosphere. Likewise, meteorological conditions impacting dispersion are complex and depend on the interaction of numerous physical processes. Therefore, any successful modeling effort must be directed by individuals with broad knowledge and experience in air pollution meteorology, as well as expertise in data processing techniques. The judgement of well trained professional analysts is essential to properly evaluate the ground level impact of pollutant emissions. Without detailed validation/calibration efforts, air quality modeling results are generally felt to be good only within an order of magnitude under many circumstances, such as applications in areas of rugged terrain.

Air quality models have been widely used to identify potential violations of National Ambient Air Quality Standards (NAAQS). Modeling studies of the atmosphere are useful in determining emission limits for industrial development in specified areas. Hence, dispersion models are vital to the timely and cost effective development of air pollution control strategies for most regions. Ideally, mathematical modeling of the dispersion potential of the atmosphere would allow optimum planning for proposed land use development in terms of minimizing the air pollution impact. Dispersion models provide a technique which can be used to help ensure attainment and maintenance of air quality standards and to prevent significant air quality deterioration due to future development.

This section is designed to present a basic understanding of dispersion modeling approaches to air quality problems. The subsections to follow will allow the reader to understand the concepts of mathematical air quality modeling. Numerous models are described as well as techniques for selecting the optimum approach. English units, which have been employed in previous sections of this document, will not be used here. Calculations must be performed in metric units, as dictated by the equations and figures commonly used in dispersion modeling. English conversions, however, have been placed on figures as a convenient reference for the reader.

4.10.1 Classes of Models

Basically, there are four general types of air quality models available. These types of dispersion models are characterized as:

- Gaussian
- Numerical
- Statistical or Empirical
- Physical

Within each of these classes, there exists a large number of individual computational algorithms, each with its own specific application. For example, numerous air quality models have been developed based upon the Gaussian or log-normal solution to the fluid transport equation. Each particular model or algorithm is designed to handle a specific air quality and atmospheric scenario while computing pollution impacts through the use of the Gaussian diffusion equation. The models may, for example, consider different atmospheric parameters, terrain features, and various degrees of data resolution. The well-known EPA dispersion models such as the Climatological Dispersion Model (CDM), the Air Quality Display Model (AQDM), the Valley Model, and the Texas Climatological Model (TCM) are commonly referred to as individual models but in fact are all variations of the basic Gaussian model. In many cases, the only real difference between models is the degree of detail considered in the input and output of data.

Gaussian models are considered to be the state of the art technique for estimating the impact of non-reactive pollutants. These types of models assume instantaneous transport of effluents downwind of the emission source. However, numerical models are more appropriate than Gaussian models for source applications which involve reactive pollutants. Most numerical models employ numerous interactive steps allowing for downwind adjustments to time dependent chemical and thermal processes that take place in the plume. Statistical or empirical techniques are frequently employed in situations where an incomplete scientific understanding of the physical and chemical processes of the plume behavior makes the use of the Gaussian and numerical modeling approaches impractical. Physical modeling, the fourth generic type, involves the use of a wind tunnel or other fluid modeling facilities necessary to investigate dispersion in very confined, specialized environments isolated to only a few square kilometers. Physical modeling is a complex process which requires a high level of technical expertise.

4.10.2 Model Suitability and Application

The level of analysis for which a particular dispersion model is well suited depends on several factors. These include:

- The detail and accuracy of the data base (i.e., emission inventory, baseline air quality and meteorological data)
- The local topographic and meteorological complexities
- The technical competence of the individuals directing the modeling effort

- Available financial and computational resources

Air quality models require a data base which includes emission source characteristics, meteorological parameters and baseline air quality levels (and at times, local topographic data and temporal statistics). Models that require detailed and precise input data should not be applied when such data are unavailable.

Most dispersion models are intended for use only in areas of relatively simple topography. Specific modeling analyses for major topographic features and complex meteorological scenarios may start with a simplistic preliminary screening analyses using the Gaussian or other straightforward approach to define the level of impact. If these analyses point to a potentially important impact then more sophisticated modeling approaches must be implemented.

Applications of the various classes of air quality models previously mentioned require a two step approach with various levels of sophistication. The first level consists of general techniques that provide relatively simple and conservative estimates of air quality impact of a specific source or source category. This initial screening level, provides an understanding of air pollution impact due to a particular source(s) in the area in question. The major objective at this stage is to identify potential violations of air quality standards. This is done by using simple analytical techniques to isolate areas of projected maximum ground level concentrations for comparison with the most limiting standards, and is the level of effort the District Offices should strive to accomplish.

The second level of effort involves the use of analytical techniques which provide a more detailed treatment of physical and chemical processes once a potential problem has been identified. This step requires a more detailed and precise data base which will result in a more accurate estimate of source impact. At this point, an exhaustive data base specific to the study area is incorporated into the modeling analysis. For example, temporal variations in the baseline meteorology, air quality and emissions data can be input to the model. Emission inventory data can also be more accurately assessed in terms of such aspects as temporal variability.

The screening level approach to air quality modeling is highly recommended in all initial applications of dispersion models. If a problem is identified, then more sophisticated analyses are indicated. In any case, a multi-step approach to modeling is vital in accurately establishing regional air quality impact.

A specific plan of attack is required for each dispersion problem that is encountered. It is not the purpose of this section to recommend specific models for specific air quality

impact situations, but rather to provide a foundation or framework in which to approach the basic air quality modeling problem, which may be used as a screening level to determine if further analysis is needed.

4.10.3 The Gaussian Model

Gaussian based models are considered to be the state of the art technique for estimating concentrations of non-reactive pollutants such as sulfur dioxide and particulate matter for most point source emissions. Numerous experiments have been conducted to study the shape of plumes. The publication "Meteorology and Atomic Energy" lists over twenty experiments, many of which have been conducted by the Atomic Energy Commission (now ERDA-Energy Research and Development Administration). In general, most investigators have been satisfied that a Gaussian distribution is a good mathematical approximation of plume behavior over time periods on the order of five minutes to one hour. Figure 4.10-1 illustrates the Gaussian plume distribution in the horizontal and the vertical.

The Gaussian model provides reasonable estimates in flat or gently rolling terrain. However, Gaussian based models are extremely inaccurate for air quality impact assessments in areas comprised of extremely rugged and varying terrain, such as hilly or mountainous regions. For such situations, statistical or physical modeling methods are best employed, since the dispersion potential of the atmosphere can then be characterized by empirical data obtained by local monitoring programs.

Properly used, a Gaussian model is unequalled as a practical diffusion modeling tool in terms of simplicity, flexibility and the successful correlation between predicted and measured values. For these reasons, the Gaussian model is used in this section to illustrate several simple modeling problems. All variables which will be used to solve the Gaussian equation will now be defined:

- $C(x,y,z)$ is the concentration at a point (x,y,z) .
- \bar{x} is the mean
- σ_y, σ_z are the standard deviations in the y and z directions
- Q is the emission rate
- \bar{u} is the mean wind speed and
- H is the height of the plume centerline when it becomes essentially level.

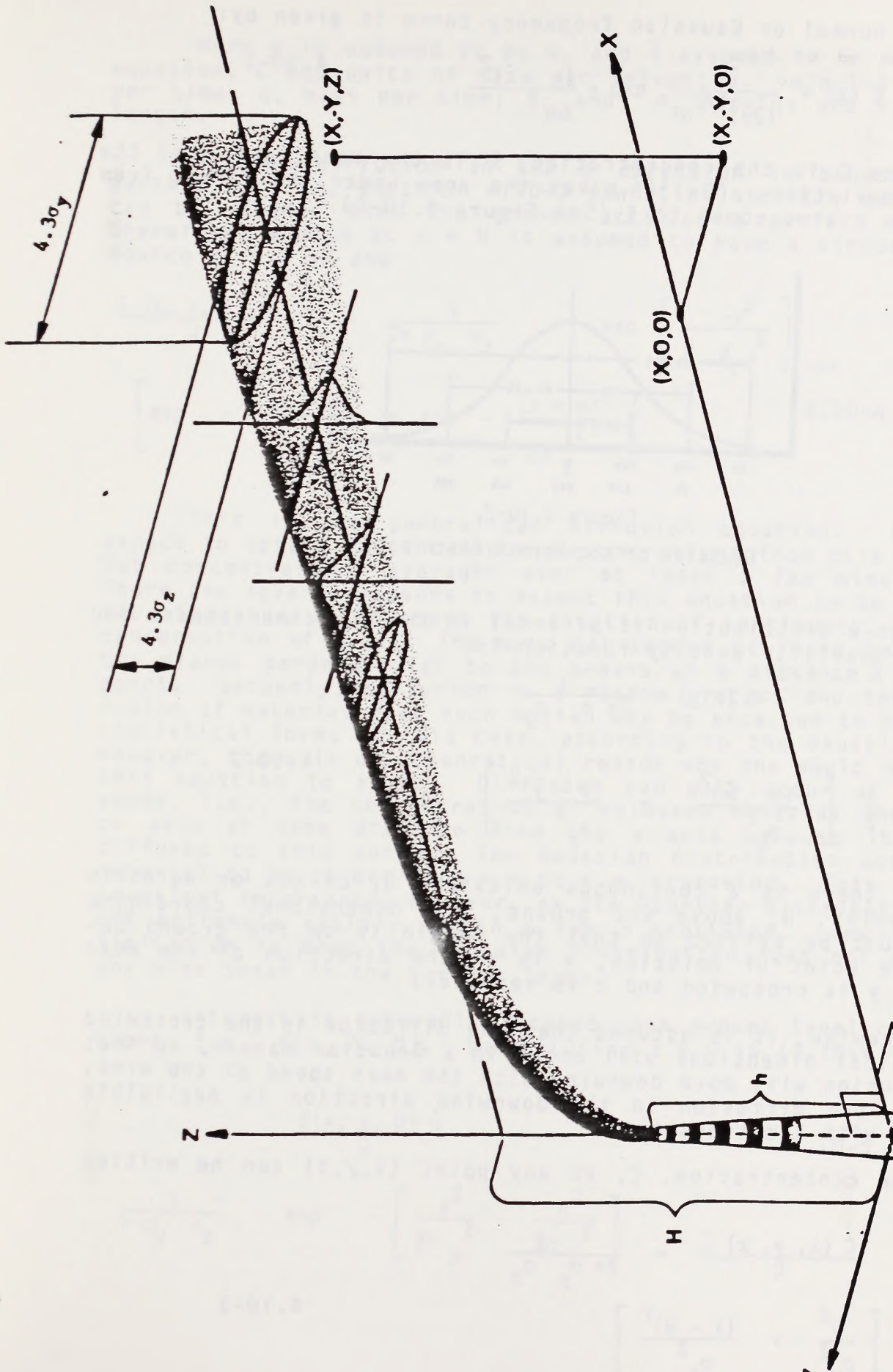

Figure 4.10-1
 Coordinate System Showing
 GAUSSIAN Distribution in the Horizontal and Vertical

The normal or Gaussian frequency curve is given by:

$$C(x) = \frac{1}{(2\pi)^{1/2}\sigma} \exp - \frac{(x - \bar{x})^2}{2\sigma^2} \quad 4.10-1$$

Where C is the concentration, \bar{x} , is the mean, and σ is the standard deviation. $(2\pi)^{1/2}$ makes the area under the curve, from $x = -\infty$ to $+\infty$, equal to 1 (See Figure 4.10-2).

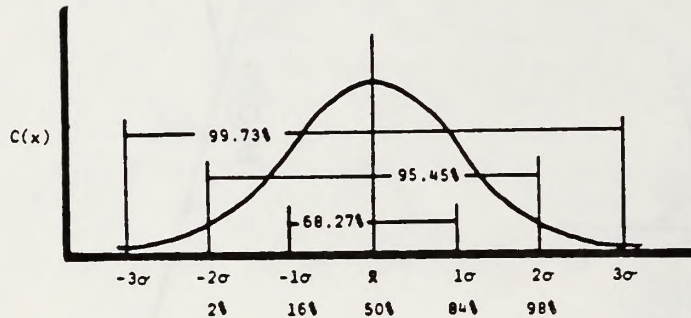

Figure 4.10-2

Gaussian or Log-Normal Distribution

When a distribution is binormal in the two dimensions x and y, the probability density function is:

$$C(x,y) = \frac{1}{2\pi \sigma_x \sigma_y}$$

$$\exp - \frac{1}{2} \left[\frac{(x - \bar{x})^2}{\sigma_x^2} + \frac{(y - \bar{y})^2}{\sigma_y^2} \right] \quad 4.10-2$$

If there is a continuous emission, Q, of gas or aerosols from a point, H, above the ground, a 3 dimensional coordinate system must be defined so that the origin is on the ground beneath the point of emission, x is in the direction of the mean wind, \bar{u} , y is crosswind and z is vertical.

Likewise, it is assumed that the diffusion in the crosswind and vertical dimensions will occur in a Gaussian manner, so that the pollution will move downwind with the mean speed of the wind, and that the diffusion in the downwind direction is negligible compared with the transport.

The concentration, C, at any point (x,y,z) can be written as:

$$\frac{C(x,y,z) \bar{u}}{Q} = \frac{1}{2\pi \sigma_y \sigma_z}$$

$$\exp - \frac{1}{2} \left[\frac{y^2}{\sigma_y^2} + \frac{(z - H)^2}{\sigma_z^2} \right] \quad 4.10-3$$

Here y is assumed to be 0, and \bar{z} assumed to be H . In this equation, C has units of mass per volume; \bar{u} , velocity or length per time; Q , mass per time; σ_y and σ_z length; and y, z , and H , length.

Because diffusion in the z direction is bounded by the earth's surface, equation 4.10-3 cannot be strictly used. If it can be assumed that the ground acts as a perfect reflector, therefore, source at $z = H$ is assumed to have a virtual "image" source at $z = -H$ and

$$\frac{C(x, y, z) \bar{u}}{Q} = \frac{1}{2\pi \sigma_y \sigma_z} \exp \left[\frac{-y^2}{2 \sigma_y^2} \right] \left[\exp - \frac{(z - H)^2}{2 \sigma_z^2} + \exp - \frac{(z + H)^2}{2 \sigma_z^2} \right] \quad 4.10-4$$

This is the generalized diffusion equation. We cannot expect to obtain instantaneous concentrations from this equation, but concentrations averaged over at least a few minutes time. There are several reasons to expect this equation to be valid for the atmosphere. It obeys the equation of continuity, i.e., the conservation of mass. The mass Q/l second is found between any two planes perpendicular to the x -axis at a distance \bar{u}/l second apart. Secondly, diffusion is a random process and the distribution of material from such motion may be expected to be in some statistical form; in this case, according to the Gaussian curve. However, there is one theoretical reason why one would not expect this equation to apply. Diffusion can only occur at a finite speed, i.e., the concentration of released material should drop to zero at some distance from the x axis because it has not diffused to this point. The Gaussian distribution assumes the material to be spread from $-\infty$ to $+\infty$ crosswind. This is not of practical importance, however, as the Gaussian distribution drops off extremely rapidly within a few σ crosswind. One practical limitation is that the Gaussian distribution does not allow for any wind shear in the surface layer.

Interest is generally focused upon ground level concentrations, i.e., $C(x, Y, 0)$. Substituting $z = 0$ in (4.10-4) yields:

$$\frac{C(x, y, 0) \bar{u}}{Q} = \frac{1}{\pi \sigma_y \sigma_z} \exp \left[\frac{-y^2}{2 \sigma_y^2} - \frac{H^2}{2 \sigma_z^2} \right] \quad 4.10-5$$

It will be noted that the 2 in the denominator in (4.10-4) is eliminated in (4.10-5) because of the 2

resulting from $2 \exp - \frac{H^2}{2\sigma_z^2}$ occurring in the numerator.

If the source is at ground level ($H = 0$), there is further simplification. Similarly, if one is interested only in center-line concentrations (directly downwind) then $y = 0$, and equation (4.10-5) may again be simplified.

This (4.10-5) is the basic equation for calculating the ground level concentration from a continuous point source. The usual units for the variables are:

$C(x, y, 0)$	gms/m ³
\bar{u}	m/sec
Q	gms/sec
$\sigma_y, \sigma_z, y, H,$	meters

As seen from Equation 4.10-5, the plume concentration (C) at various downwind distances (x) from the emission source is largely dependent upon horizontal and vertical dispersion coefficients (σ_y or σ_z). Figure 4.10-1 illustrates the coordinate system for a typical plume and visually describes the significance of the dispersion coefficients in the y and z directions.

Stability

The values of both σ_y and σ_z will depend upon the turbulent structure of the atmosphere. If measures of horizontal and vertical motions of the air are made as with a bivane, the resulting records may be used to estimate σ_y and σ_z (see Pasquill, 1961). If wind fluctuation measurements are not available, estimates of σ_y and σ_z may be made by first estimating the stability of the atmosphere from wind measurements at the standard height of 10 meters, and estimates of net radiation (Pasquill, 1961). Stability categories (in six classes) are given in Table 4.10-1 in terms of insolation during daytime (radiation received from the sun) and amount of cloud cover at night. Strong insolation corresponds to a solar altitude (above the horizon) greater than 60° with clear skies, and slight insolation corresponds to a solar altitude from 15° to 35° with clear skies. Table 170, Solar Altitude, and Azimuth in the Smithsonian Meteorological Tables (List, 1951) is a considerable aid in determining insolation. Cloudiness will generally decrease insolation and should be considered along with a solar altitude in determining insolation. Insolation that would be strong with clear skies may be reduced to moderate with broken middle clouds and to slight with broken low clouds. Night refers to the period from one hour before sunset to one hour after sunrise. The neutral category, (D), should be assumed for overcast conditions during day or night.

Table 4.10-1
Key to Stability Categories

Surface Wind Speed (at 10 m) m/sec	Insolation			Night	
	Strong	Moderate	Slight	Thinly Overcast or $\geq 4/8$ Low Cloud	$\leq 3/8$ Cloud
< 2	A	A-B	B	-	-
2-3	A-B	B	C	E	F
3-5	B	B-C	C	D	E
5-6	C	C-D	D	D	D
> 6	C	D	D	D	D

The neutral category, D, should be assumed for overcast conditions during day or night.

Estimation of Vertical and Horizontal Dispersion

Having determined the stability class from Table 4.10-1, the measures of diffusion in the vertical, σ_z , and in the horizontal, σ_y , may be estimated as a function of downwind distance from the source, (x), using Figures 4.10-3 and 4.10-4. These values of σ_z and σ_y are valid for concentrations, (C), averaged over a few minutes time, and apply to open level country with no allowance made for turbulence due to buildings or topography. With very light winds on a clear night, the vertical spread may be less than the values for class F.

When conditions are such that the vertical structure of temperature indicates a definite limit to the vertical convection, particularly under unstable conditions, the σ_z should be allowed to increase only to $0.47h_1$ where h_1 is the limit of convection. At the distance x_1 where $\sigma_z = 0.47 h_1$, the plume is still assumed to have a Gaussian vertical distribution. It can be assumed that by the time the plume travels twice this distance ($2x_1$), the plume has become uniformly distributed between the earth's surface and the limit of convection. A value of σ_z equal to $0.8h_1$ may be used and the exponential term dropped at distances equal to or greater than $2x_1$ and will make the concentration value computed by the equation, equal to that from a plume uniformly distributed in the vertical.

Estimation of Wind Speed

For mean wind speed, (\bar{u}), the value measured at 10 meters elevation (surface wind) should be used for x up to about 1 km for surface sources or short stacks. For greater distances or elevated sources, a mean speed through the vertical extent of the plume (about $2\sigma_z$) should be used. A speed midway between the surface and geostrophic speeds should be reasonable.

Calculation of Centerline Concentration From a Ground Level Source

For most practical purposes it will be sufficient to calculate the centerline concentration for the distances 100 m, 1 km, 10 km, and 100 km and plot these against downwind distance x, on log/log graph paper for interpolation of concentration for other distances. (For unstable or stable cases it is desirable to include several other distances.) This may be done using the equation:

$$C = \frac{Q}{\pi u \sigma_y \sigma_z} = \frac{3.18 \times 10^{-1} Q}{u \sigma_y \sigma_z} \quad 4.10-6$$

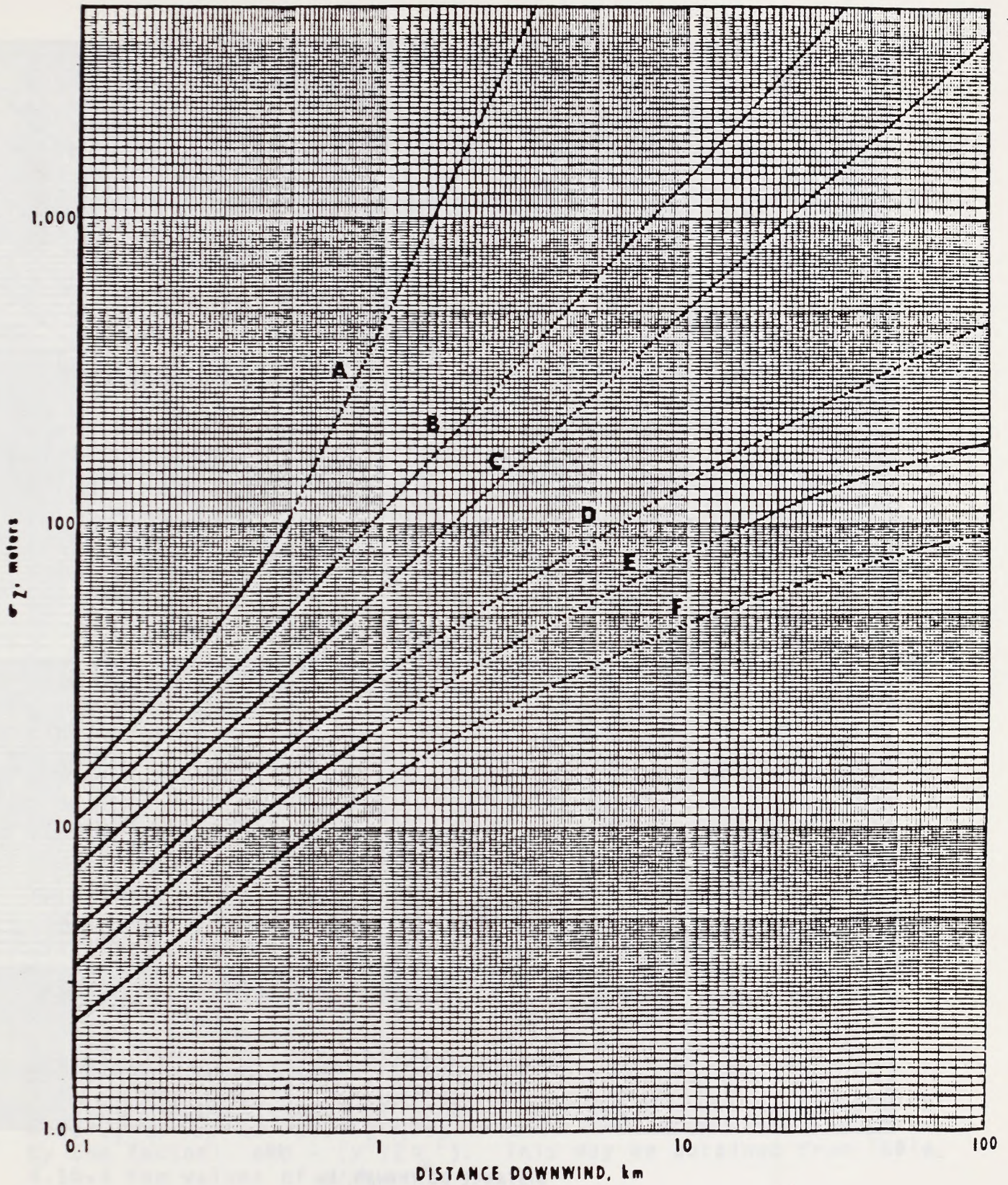

Figure 4.10-3

Vertical Dispersion Coefficient as a Function
of Downwind Distance from the Source

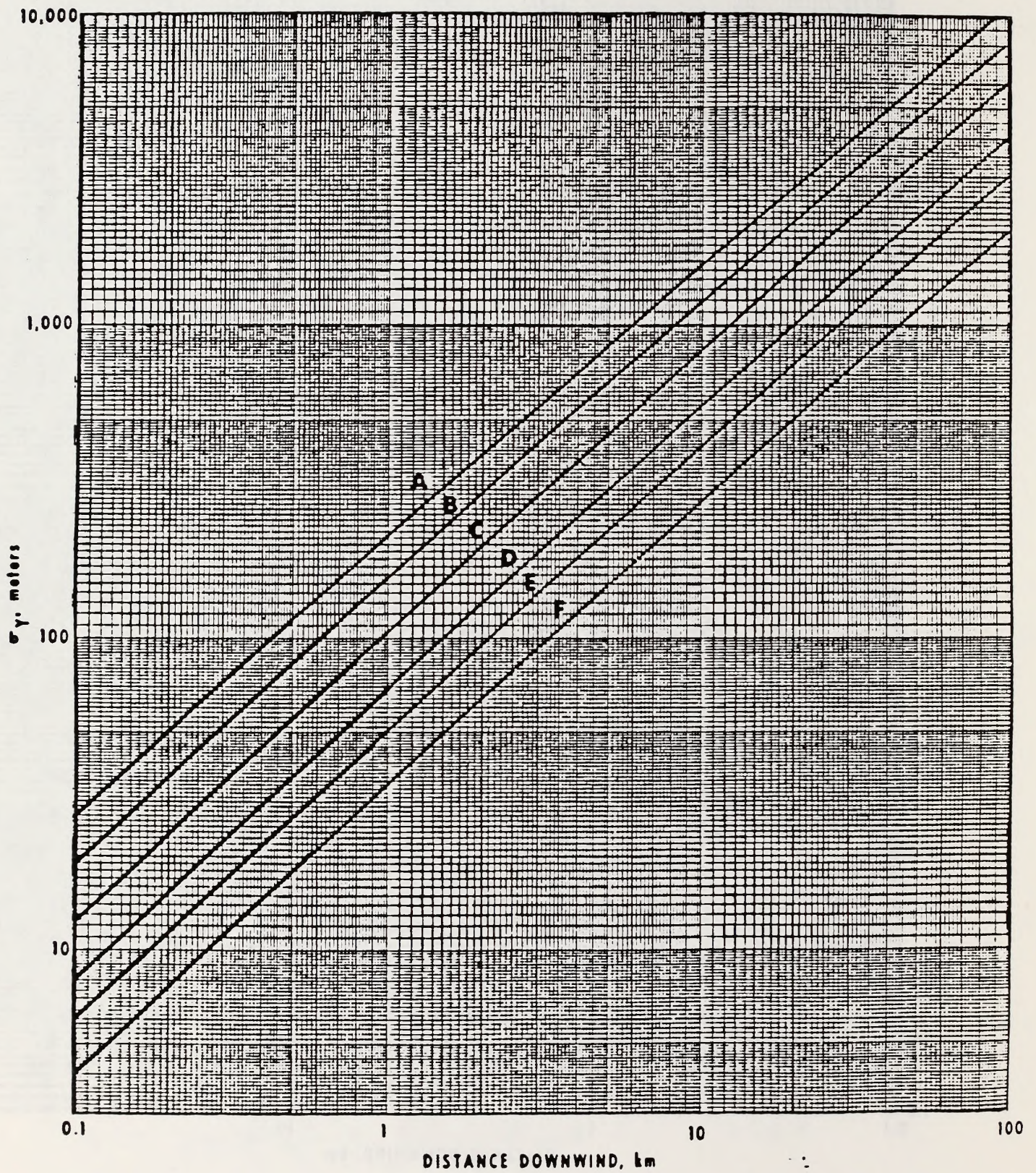

Figure 4.10-4

Horizontal Dispersion Coefficient as a Function of Downwind Distance from the Source

The zero subscript of C, concentration, indicates emission from a ground-level source. If there is a limit to convection (h), concentrations should also be calculated for distances x_1 and x_2 using $\sigma_z = 0.47h_1$ and $\sigma_z = 0.8 h_1$ respectively. Line segments connecting the calculated concentrations for the various distances will give a plot of concentration with distance.

Calculation of Ground-Level Centerline Concentration From an Elevated Source

Concentrations from an elevated source may be calculated from:

$$C = \frac{Q}{\pi u \sigma_y \sigma_z} \exp - \frac{H^2}{2 \sigma_z^2} \quad 4.10-7$$

where H is the effective height i.e., the physical stack height plus plume rise, of the elevated source.

Values of $\exp - H^2/2 \sigma_z^2$ are found in Table 4.10-2. A is the ratio of H/σ_z and B, the expression in the body of the table, is the computed value of the exponential. The E represents $\times 10$ to the power indicated by the following two digits. For example, if A = 3.55, the value of the exponential is 0.183×10^{-2} .

It is possible under light wind situations at nights that the plume from an elevated source will remain aloft with no significant vertical diffusion, in which case the ground-level concentrations would be zero. Vertical spread can then be started at a downwind position corresponding to the wind speed and the estimated time for breakdown of the stable situation.

Graphs for Estimation of Diffusion

Hilsmeier and Gifford (1962) have presented graphs of relative concentration times wind speed (Cu/Q) below the plume centerline, versus downwind distance for various stability classes. Figure 4.10-5 give Cu/Q as a function of x for a ground-level source whereas Figures 4.10-6 through 4.10-8 are for the indicated elevated sources.

Calculation of Off Axis Concentrations

Off-Axis concentrations may be calculated from equation 4.10-1, or by correcting ground-level centerline concentrations by the factor: $\exp - (y^2/2 \sigma_y^2)$. This may be obtained from Table 4.10-3 for values of y/σ_y .

Plotting Ground-Level Concentration Isoleths

Table 4.10-2

$$\text{Values of } \exp - \frac{H^2}{2\sigma_z^2}$$

A	B = exp - 1/2(A) ²									
	0.00	0.01	0.02	0.03	0.04	0.05	0.06	0.07	0.08	0.09
0.00	0.100E 01	0.100E 01	0.100E 01	0.100E 01	0.999E 00	0.999E 00	0.998E 00	0.998E 00	0.997E 00	0.995E 00
0.10	0.995E 00	0.994E 00	0.993E 00	0.992E 00	0.990E 00	0.988E 00	0.987E 00	0.986E 00	0.984E 00	0.982E 00
0.20	0.980E 00	0.978E 00	0.976E 00	0.974E 00	0.972E 00	0.969E 00	0.967E 00	0.964E 00	0.962E 00	0.959E 00
0.30	0.956E 00	0.953E 00	0.950E 00	0.947E 00	0.944E 00	0.941E 00	0.937E 00	0.934E 00	0.930E 00	0.927E 00
0.40	0.923E 00	0.919E 00	0.916E 00	0.912E 00	0.908E 00	0.904E 00	0.900E 00	0.895E 00	0.891E 00	0.887E 00
0.50	0.882E 00	0.878E 00	0.874E 00	0.869E 00	0.864E 00	0.860E 00	0.855E 00	0.850E 00	0.845E 00	0.840E 00
0.60	0.835E 00	0.830E 00	0.825E 00	0.820E 00	0.815E 00	0.810E 00	0.804E 00	0.799E 00	0.794E 00	0.788E 00
0.70	0.783E 00	0.777E 00	0.772E 00	0.766E 00	0.760E 00	0.755E 00	0.749E 00	0.743E 00	0.738E 00	0.732E 00
0.80	0.726E 00	0.720E 00	0.714E 00	0.709E 00	0.703E 00	0.697E 00	0.691E 00	0.685E 00	0.679E 00	0.673E 00
0.90	0.667E 00	0.661E 00	0.655E 00	0.649E 00	0.643E 00	0.637E 00	0.631E 00	0.625E 00	0.619E 00	0.613E 00
1.00	0.607E 00	0.600E 00	0.594E 00	0.588E 00	0.582E 00	0.576E 00	0.570E 00	0.564E 00	0.558E 00	0.552E 00
1.10	0.546E 00	0.540E 00	0.534E 00	0.528E 00	0.522E 00	0.516E 00	0.510E 00	0.504E 00	0.498E 00	0.493E 00
1.20	0.487E 00	0.481E 00	0.475E 00	0.469E 00	0.464E 00	0.458E 00	0.452E 00	0.446E 00	0.441E 00	0.435E 00
1.30	0.430E 00	0.424E 00	0.418E 00	0.413E 00	0.407E 00	0.402E 00	0.397E 00	0.391E 00	0.386E 00	0.381E 00
1.40	0.375E 00	0.370E 00	0.365E 00	0.360E 00	0.355E 00	0.350E 00	0.344E 00	0.339E 00	0.334E 00	0.330E 00
1.50	0.325E 00	0.320E 00	0.315E 00	0.310E 00	0.306E 00	0.301E 00	0.296E 00	0.292E 00	0.287E 00	0.283E 00
1.60	0.278E 00	0.274E 00	0.269E 00	0.265E 00	0.261E 00	0.256E 00	0.252E 00	0.248E 00	0.244E 00	0.240E 00
1.70	0.236E 00	0.232E 00	0.228E 00	0.224E 00	0.220E 00	0.216E 00	0.213E 00	0.209E 00	0.205E 00	0.201E 00
1.80	0.198E 00	0.194E 00	0.191E 00	0.187E 00	0.184E 00	0.181E 00	0.177E 00	0.174E 00	0.171E 00	0.168E 00
1.90	0.164E 00	0.161E 00	0.158E 00	0.155E 00	0.152E 00	0.149E 00	0.146E 00	0.144E 00	0.141E 00	0.138E 00
2.00	0.135E 00	0.133E 00	0.130E 00	0.127E 00	0.125E 00	0.122E 00	0.120E 00	0.117E 00	0.115E 00	0.113E 00
2.10	0.110E 00	0.108E 00	0.106E 00	0.103E 00	0.101E 00	0.991E-01	0.970E-01	0.949E-01	0.929E-01	0.909E-01
2.20	0.889E-01	0.870E-01	0.851E-01	0.832E-01	0.814E-01	0.796E-01	0.778E-01	0.760E-01	0.743E-01	0.727E-01
2.30	0.710E-01	0.694E-01	0.678E-01	0.662E-01	0.647E-01	0.632E-01	0.617E-01	0.603E-01	0.589E-01	0.575E-01
2.40	0.561E-01	0.548E-01	0.535E-01	0.522E-01	0.510E-01	0.497E-01	0.485E-01	0.473E-01	0.462E-01	0.450E-01
2.50	0.439E-01	0.428E-01	0.418E-01	0.407E-01	0.397E-01	0.387E-01	0.377E-01	0.368E-01	0.359E-01	0.349E-01
2.60	0.340E-01	0.332E-01	0.323E-01	0.315E-01	0.307E-01	0.299E-01	0.291E-01	0.283E-01	0.276E-01	0.268E-01
2.70	0.261E-01	0.254E-01	0.247E-01	0.241E-01	0.234E-01	0.228E-01	0.222E-01	0.216E-01	0.210E-01	0.204E-01
2.80	0.198E-01	0.193E-01	0.188E-01	0.182E-01	0.177E-01	0.172E-01	0.167E-01	0.163E-01	0.158E-01	0.154E-01
2.90	0.149E-01	0.145E-01	0.141E-01	0.137E-01	0.133E-01	0.129E-01	0.125E-01	0.121E-01	0.118E-01	0.114E-01
3.00	0.111E-01	0.108E-01	0.105E-01	0.101E-01	0.984E-02	0.955E-02	0.926E-02	0.898E-02	0.871E-02	0.845E-02
3.10	0.819E-02	0.794E-02	0.769E-02	0.746E-02	0.723E-02	0.700E-02	0.679E-02	0.658E-02	0.637E-02	0.617E-02
3.20	0.598E-02	0.579E-02	0.560E-02	0.543E-02	0.525E-02	0.509E-02	0.492E-02	0.477E-02	0.461E-02	0.446E-02
3.30	0.432E-02	0.418E-02	0.404E-02	0.391E-02	0.378E-02	0.366E-02	0.354E-02	0.342E-02	0.331E-02	0.320E-02
3.40	0.309E-02	0.299E-02	0.289E-02	0.279E-02	0.269E-02	0.260E-02	0.251E-02	0.243E-02	0.235E-02	0.227E-02
3.50	0.214E-02	0.211E-02	0.204E-02	0.197E-02	0.190E-02	0.183E-02	0.177E-02	0.171E-02	0.165E-02	0.159E-02
3.60	0.153E-02	0.148E-02	0.143E-02	0.138E-02	0.133E-02	0.128E-02	0.123E-02	0.119E-02	0.115E-02	0.110E-02
3.70	0.106E-02	0.103E-02	0.989E-03	0.952E-03	0.918E-03	0.884E-03	0.851E-03	0.820E-03	0.789E-03	0.760E-03
3.80	0.732E-03	0.704E-03	0.678E-03	0.653E-03	0.628E-03	0.604E-03	0.582E-03	0.560E-03	0.538E-03	0.518E-03
3.90	0.498E-03	0.479E-03	0.460E-03	0.443E-03	0.428E-03	0.409E-03	0.393E-03	0.378E-03	0.363E-03	0.349E-03
4.00	0.335E-03	0.322E-03	0.310E-03	0.297E-03	0.286E-03	0.274E-03	0.263E-03	0.253E-03	0.243E-03	0.233E-03
4.10	0.224E-03	0.215E-03	0.206E-03	0.198E-03	0.190E-03	0.182E-03	0.175E-03	0.168E-03	0.161E-03	0.154E-03
4.20	0.148E-03	0.142E-03	0.136E-03	0.130E-03	0.125E-03	0.120E-03	0.115E-03	0.110E-03	0.105E-03	0.101E-03
4.30	0.966E-04	0.925E-04	0.888E-04	0.849E-04	0.813E-04	0.778E-04	0.745E-04	0.713E-04	0.683E-04	0.653E-04
4.40	0.625E-04	0.598E-04	0.572E-04	0.548E-04	0.524E-04	0.501E-04	0.479E-04	0.458E-04	0.438E-04	0.419E-04
4.50	0.401E-04	0.383E-04	0.366E-04	0.350E-04	0.334E-04	0.320E-04	0.305E-04	0.292E-04	0.279E-04	0.266E-04
4.60	0.254E-04	0.243E-04	0.232E-04	0.221E-04	0.211E-04	0.202E-04	0.193E-04	0.184E-04	0.175E-04	0.167E-04
4.70	0.160E-04	0.152E-04	0.145E-04	0.139E-04	0.132E-04	0.126E-04	0.120E-04	0.115E-04	0.109E-04	0.104E-04
4.80	0.993E-05	0.946E-05	0.902E-05	0.859E-05	0.819E-05	0.780E-05	0.743E-05	0.708E-05	0.674E-05	0.642E-05
4.90	0.611E-05	0.582E-05	0.554E-05	0.528E-05	0.502E-05	0.478E-05	0.455E-05	0.433E-05	0.412E-05	0.392E-05

Table 4.10-2 (Continued)

$$B = \exp - \frac{1}{2}(A)^2$$

A	0.00	0.01	0.02	0.03	0.04	0.05	0.06	0.07	0.08	0.09
5.00	0.373E-05	0.354E-05	0.337E-05	0.321E-05	0.305E-05	0.290E-05	0.276E-05	0.262E-05	0.249E-05	0.237E-05
5.10	0.225E-05	0.214E-05	0.203E-05	0.193E-05	0.183E-05	0.174E-05	0.165E-05	0.157E-05	0.149E-05	0.142E-05
5.20	0.134E-05	0.128E-05	0.121E-05	0.115E-05	0.109E-05	0.103E-05	0.982E-06	0.932E-06	0.884E-06	0.838E-06
5.30	0.795E-06	0.754E-06	0.715E-06	0.678E-06	0.643E-06	0.609E-06	0.577E-06	0.547E-06	0.519E-06	0.491E-06
5.40	0.466E-06	0.441E-06	0.418E-06	0.396E-06	0.375E-06	0.355E-06	0.336E-06	0.318E-06	0.301E-06	0.285E-06
5.50	0.270E-06	0.255E-06	0.242E-06	0.229E-06	0.216E-06	0.205E-06	0.194E-06	0.183E-06	0.173E-06	0.164E-06
5.60	0.155E-06	0.147E-06	0.139E-06	0.131E-06	0.124E-06	0.117E-06	0.111E-06	0.104E-06	0.987E-07	0.932E-07
5.70	0.881E-07	0.832E-07	0.786E-07	0.742E-07	0.701E-07	0.662E-07	0.625E-07	0.590E-07	0.556E-07	0.525E-07
5.80	0.496E-07	0.468E-07	0.441E-07	0.416E-07	0.393E-07	0.370E-07	0.349E-07	0.329E-07	0.311E-07	0.293E-07
5.90	0.276E-07	0.260E-07	0.245E-07	0.231E-07	0.218E-07	0.205E-07	0.193E-07	0.182E-07	0.172E-07	0.162E-07
6.00	0.152E-07	0.143E-07	0.135E-07	0.127E-07	0.120E-07	0.113E-07	0.106E-07	0.998E-08	0.939E-08	0.884E-08
6.10	0.837E-08	0.782E-08	0.736E-08	0.692E-08	0.651E-08	0.612E-08	0.574E-08	0.541E-08	0.509E-08	0.478E-08
6.20	0.450E-08	0.423E-08	0.397E-08	0.373E-08	0.351E-08	0.329E-08	0.309E-08	0.291E-08	0.273E-08	0.256E-08
6.30	0.241E-08	0.226E-08	0.212E-08	0.199E-08	0.187E-08	0.175E-08	0.165E-08	0.154E-08	0.145E-08	0.136E-08
6.40	0.128E-08	0.120E-08	0.112E-08	0.105E-08	0.987E-09	0.925E-09	0.867E-09	0.813E-09	0.762E-09	0.714E-09
6.50	0.669E-09	0.627E-09	0.587E-09	0.550E-09	0.516E-09	0.483E-09	0.452E-09	0.424E-09	0.397E-09	0.371E-09
6.60	0.348E-09	0.325E-09	0.305E-09	0.285E-09	0.267E-09	0.250E-09	0.234E-09	0.218E-09	0.204E-09	0.191E-09
6.70	0.179E-09	0.167E-09	0.156E-09	0.146E-09	0.137E-09	0.128E-09	0.119E-09	0.112E-09	0.104E-09	0.974E-10
6.80	0.910E-10	0.850E-10	0.794E-10	0.742E-10	0.693E-10	0.647E-10	0.604E-10	0.564E-10	0.527E-10	0.492E-10
6.90	0.459E-10	0.428E-10	0.400E-10	0.373E-10	0.348E-10	0.325E-10	0.303E-10	0.282E-10	0.263E-10	0.246E-10
7.00	0.229E-10	0.213E-10	0.199E-10	0.186E-10	0.173E-10	0.161E-10	0.150E-10	0.140E-10	0.130E-10	0.121E-10
7.10	0.113E-10	0.105E-10	0.981E-11	0.914E-11	0.851E-11	0.792E-11	0.738E-11	0.687E-11	0.639E-11	0.595E-11
7.20	0.553E-11	0.515E-11	0.479E-11	0.446E-11	0.415E-11	0.386E-11	0.359E-11	0.334E-11	0.310E-11	0.288E-11
7.30	0.268E-11	0.249E-11	0.232E-11	0.215E-11	0.200E-11	0.186E-11	0.173E-11	0.160E-11	0.149E-11	0.138E-11
7.40	0.129E-11	0.119E-11	0.111E-11	0.103E-11	0.955E-12	0.887E-12	0.823E-12	0.764E-12	0.709E-12	0.658E-12
7.50	0.610E-12	0.566E-12	0.525E-12	0.487E-12	0.452E-12	0.419E-12	0.388E-12	0.360E-12	0.334E-12	0.309E-12
7.60	0.287E-12	0.266E-12	0.246E-12	0.228E-12	0.211E-12	0.196E-12	0.181E-12	0.168E-12	0.156E-12	0.144E-12
7.70	0.133E-12	0.124E-12	0.114E-12	0.106E-12	0.980E-13	0.907E-13	0.839E-13	0.777E-13	0.718E-13	0.663E-13
7.80	0.615E-13	0.569E-13	0.526E-13	0.486E-13	0.450E-13	0.418E-13	0.388E-13	0.359E-13	0.328E-13	0.303E-13
7.90	0.280E-13	0.259E-13	0.239E-13	0.221E-13	0.204E-13	0.189E-13	0.174E-13	0.161E-13	0.149E-13	0.137E-13
8.00	0.127E-13	0.117E-13	0.108E-13	0.996E-14	0.919E-14	0.848E-14	0.782E-14	0.722E-14	0.666E-14	0.614E-14
8.10	0.566E-14	0.522E-14	0.481E-14	0.444E-14	0.409E-14	0.377E-14	0.348E-14	0.320E-14	0.295E-14	0.272E-14
8.20	0.251E-14	0.231E-14	0.213E-14	0.196E-14	0.180E-14	0.166E-14	0.153E-14	0.141E-14	0.130E-14	0.119E-14
8.30	0.110E-14	0.101E-14	0.930E-15	0.856E-15	0.787E-15	0.724E-15	0.666E-15	0.613E-15	0.564E-15	0.518E-15
8.40	0.477E-15	0.438E-15	0.403E-15	0.370E-15	0.340E-15	0.313E-15	0.287E-15	0.264E-15	0.243E-15	0.223E-15
8.50	0.205E-15	0.188E-15	0.173E-15	0.159E-15	0.146E-15	0.134E-15	0.123E-15	0.113E-15	0.103E-15	0.949E-16
8.60	0.871E-16	0.799E-16	0.733E-16	0.672E-16	0.617E-16	0.566E-16	0.519E-16	0.476E-16	0.436E-16	0.400E-16
8.70	0.367E-16	0.336E-16	0.308E-16	0.282E-16	0.259E-16	0.237E-16	0.217E-16	0.199E-16	0.182E-16	0.167E-16
8.80	0.153E-16	0.140E-16	0.128E-16	0.117E-16	0.107E-16	0.983E-17	0.900E-17	0.823E-17	0.753E-17	0.689E-17
8.90	0.631E-17	0.577E-17	0.528E-17	0.483E-17	0.441E-17	0.404E-17	0.369E-17	0.337E-17	0.308E-17	0.282E-17
9.00	0.258E-17	0.235E-17	0.215E-17	0.197E-17	0.180E-17	0.164E-17	0.150E-17	0.137E-17	0.125E-17	0.114E-17
9.10	0.104E-17	0.952E-18	0.869E-18	0.793E-18	0.724E-18	0.661E-18	0.603E-18	0.550E-18	0.502E-18	0.458E-18
9.20	0.418E-18	0.381E-18	0.347E-18	0.317E-18	0.289E-18	0.263E-18	0.240E-18	0.219E-18	0.199E-18	0.182E-18
9.30	0.166E-18	0.151E-18	0.137E-18	0.125E-18	0.114E-18	0.104E-18	0.946E-19	0.861E-19	0.784E-19	0.714E-19
9.40	0.650E-19	0.592E-19	0.538E-19	0.490E-19	0.446E-19	0.406E-19	0.369E-19	0.336E-19	0.305E-19	0.278E-19
9.50	0.253E-19	0.230E-19	0.209E-19	0.190E-19	0.173E-19	0.157E-19	0.143E-19	0.130E-19	0.118E-19	0.107E-19
9.60	0.972E-20	0.883E-20	0.802E-20	0.727E-20	0.662E-20	0.601E-20	0.545E-20	0.493E-20	0.445E-20	0.400E-20
9.70	0.370E-20	0.336E-20	0.305E-20	0.277E-20	0.251E-20	0.228E-20	0.207E-20	0.187E-20	0.170E-20	0.154E-20
9.80	0.140E-20	0.127E-20	0.115E-20	0.104E-20	0.943E-21	0.855E-21	0.775E-21	0.702E-21	0.636E-21	0.576E-21
9.90	0.522E-21	0.472E-21	0.428E-21	0.387E-21	0.351E-21	0.318E-21	0.288E-21	0.260E-21	0.236E-21	0.213E-21

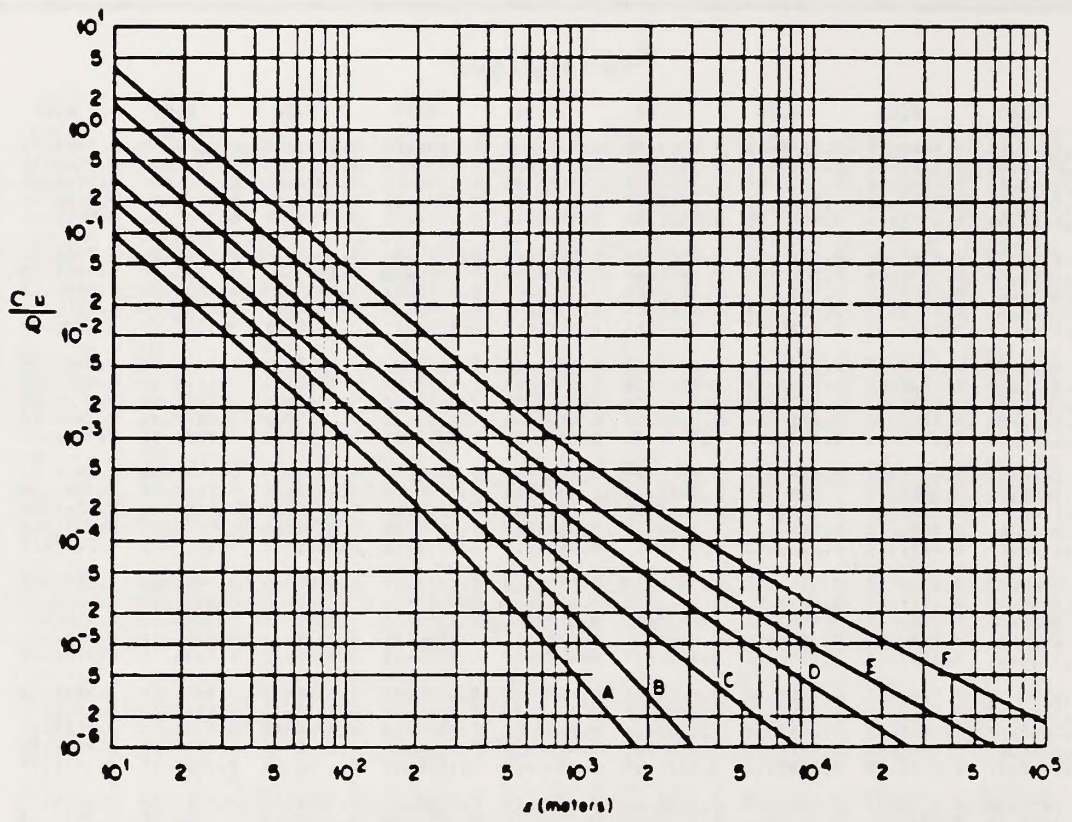

Figure 4.10-5

Values of $\frac{C_u}{Q}$ for a Ground Level Source

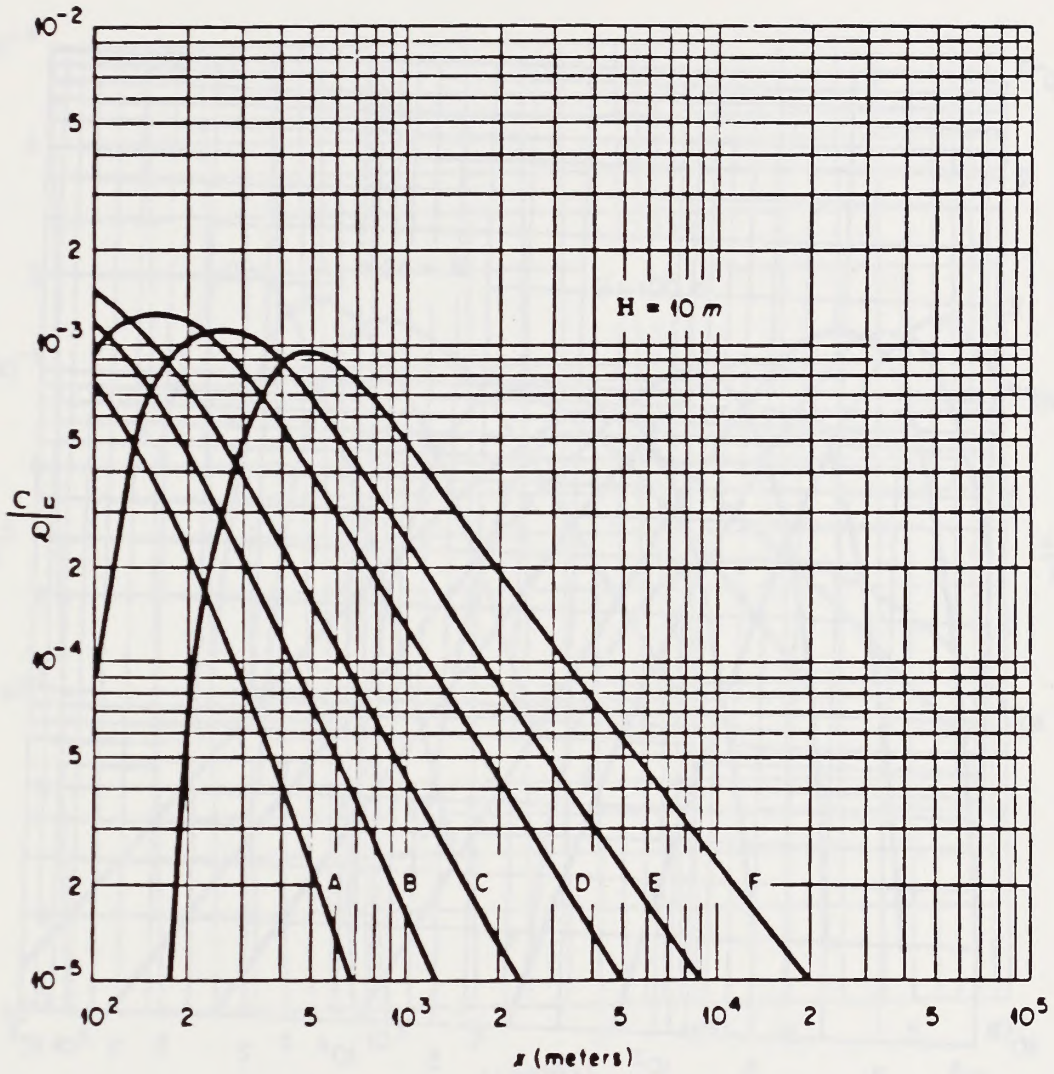

Figure 4.10-6

Values of $\frac{C_u}{Q}$ for $H = 10$ meters

1 meter = 39.37 inches

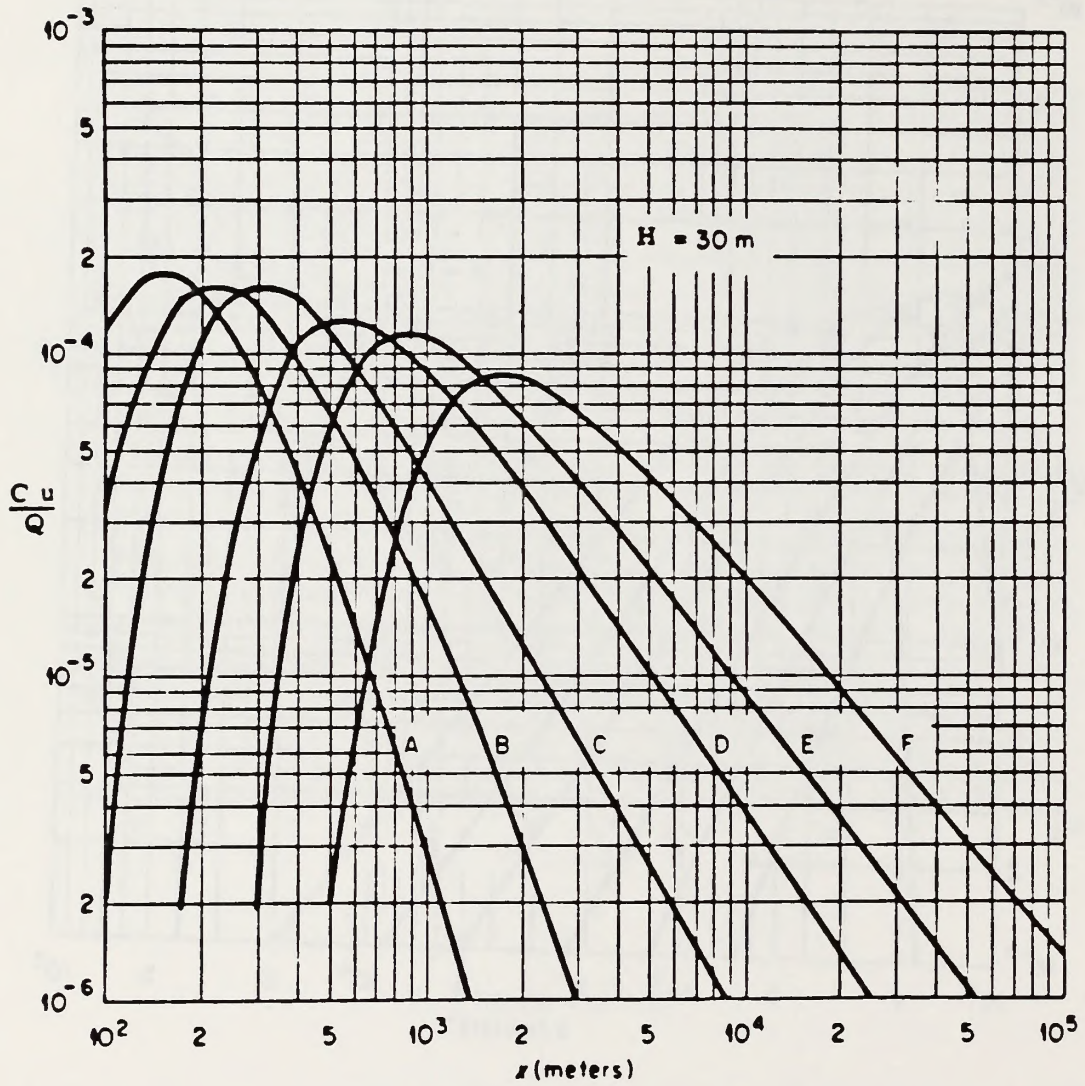

Figure 4.10-7

Values of $\frac{C_u}{C_0}$ for $H = 30$ meters

1 meter = 39.37 inches

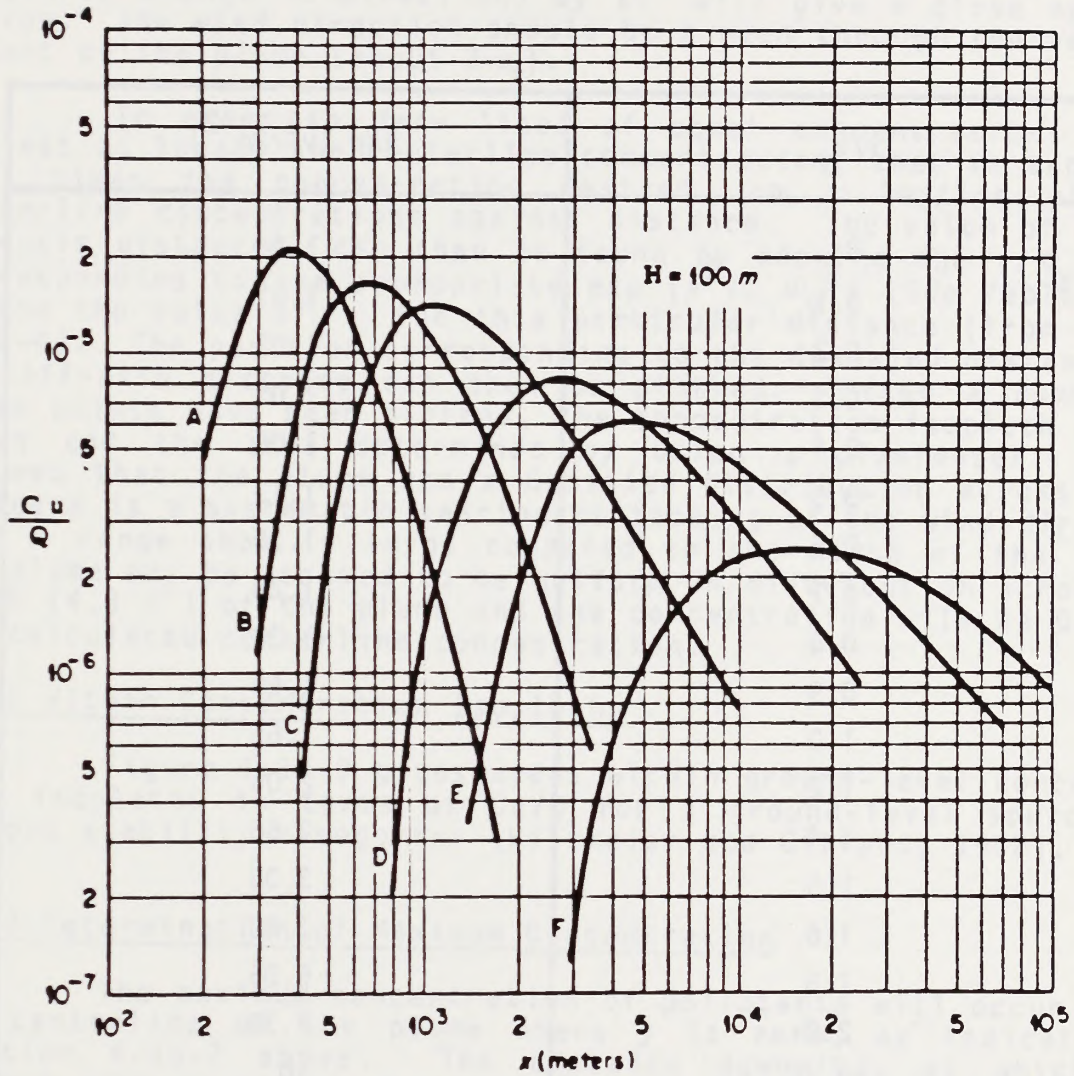

Figure 4.10-8

Values of $\frac{C_u}{Q}$ for $H = 100$ meters

1 meter = 39.37 inches

Table 4.10-3

Values of $\text{Exp} (y^2/2\sigma_y^2)$ for y/σ_y

y/σ_y	$\text{exp} (y^2/2\sigma_y^2)$
0	1.00
0.1	1.01
0.2	1.02
0.3	1.05
0.4	1.08
0.5	1.13
0.6	1.20
0.7	1.28
0.8	1.38
0.9	1.50
1.0	1.65
1.2	2.05
1.4	2.66
1.5	3.08
1.6	3.60
1.8	5.05
2.0	7.39
2.15	10
3.04	10^2
3.72	10^3
4.29	10^4
4.80	10^5

It may be of interest in a given application to plot the position of the centerline of the plume and to determine areas covered by concentrations greater than a given magnitude. First the axial position of the plume must be known. The mean wind direction will determine the position. The surface wind may be used up to 1 km. Between 1 km and 100 km, the average of the surface direction and the geostrophic direction backed (counterclockwise change in direction) by 10° will give a close approximation. The wind direction should be a mean through the vertical extent of the plume (about $2\sigma_z$).

In order to draw lines of equal concentration, it is easiest to locate the centerline concentration, that is $\exp(y^2/2\sigma_y^2)$ times the concentration desired, on a log/log plot of centerline concentrations against distance. The value of y (the off-axis distance), can then be found by knowing the y/σ_y value corresponding to the appropriate $\exp(y^2/2\sigma_y^2)$ (See Table 4.10-3) and the value of σ_y for this particular distance (from Figure 4.10-4). The position corresponding to the downwind distance and the off-axis distance can then be plotted. After a number of these points have been plotted, the concentration isopleth may be drawn and the area determined by using a planimeter. This assumes that the plume has a Gaussian distribution across wind. If there is a systematic veering or backing of the wind direction over a range that is large compared to the width of the trace, the plume may be assumed to be uniform in distribution across the width (4.3σ) of the plume and the concentration will be 0.58 of the calculated centerline concentration.

Areas Within Concentration Isopleths

Figure 4.10-9 gives areas within ground-level concentration isopleths in terms of C_u/Q for a ground-level source for various stability categories (Hilsmeier and Gifford, 1962).

Rapid Determination of Maximum Concentration

The maximum concentration of pollutants will occur along the centerline of the plume where y is zero, as indicated in equation 4.10-7 above. The distance downwind, at which the maximum concentration occurs at ground level, is a function of effective source height and stability. Figure 4.10-10 is a nomogram from which the relative value of the maximum concentration can be determined given the stability and effective source height. If the relative value of that concentration is multiplied by Q/\bar{u} , the maximum concentration for a specific set of conditions is obtained. The nomogram is designed for source strength expressed in grams/sec and wind speed in meters/sec.

Accuracy of Computations

The method will, in general, give only approximate estimates of concentrations, especially if wind fluctuation measurements are not available and estimates of dispersion are

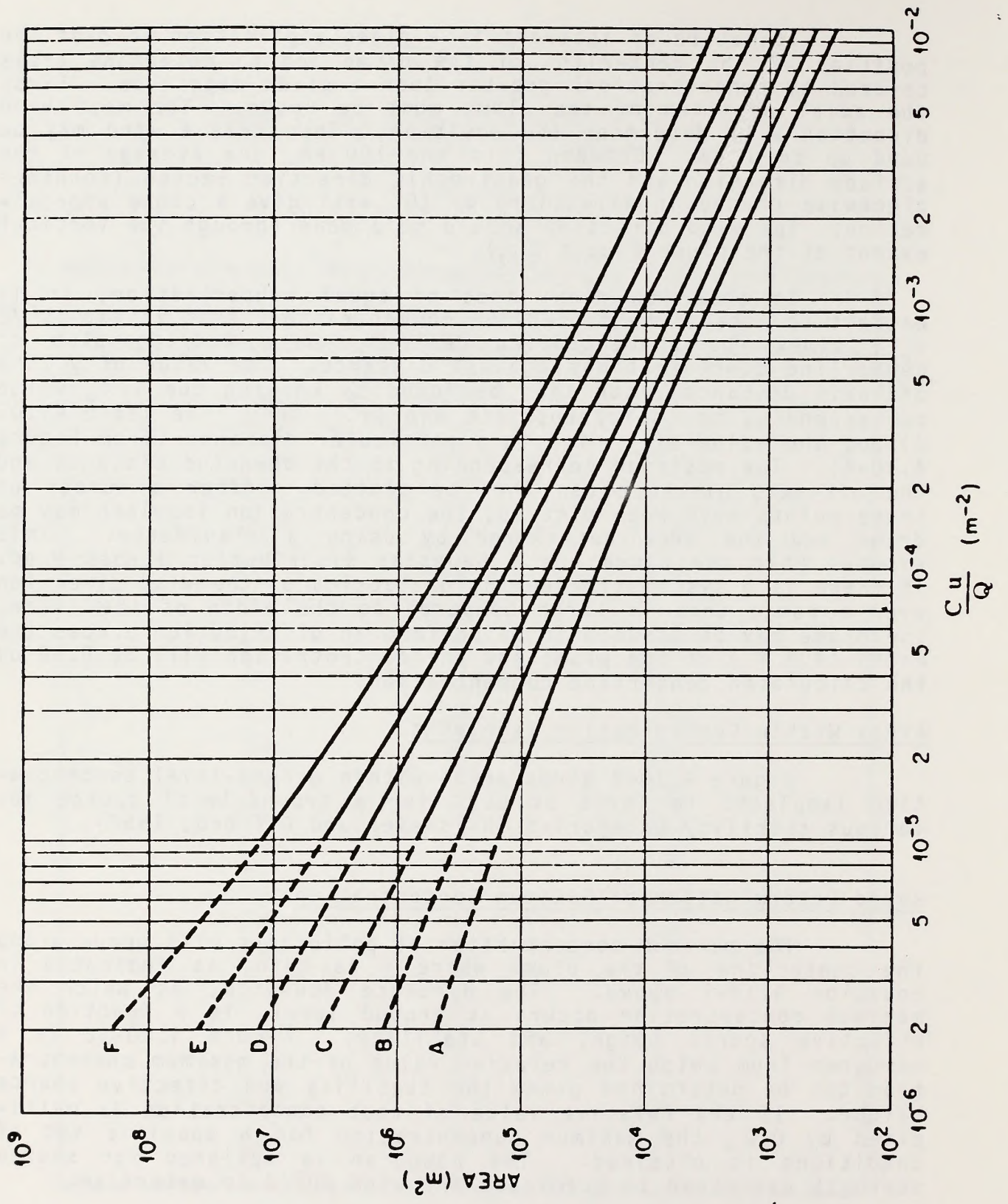

Figure 4.10-9
 Area Within Ground Level Concentration Isopleths for
 Values of Cu/Q and Atmospheric Stability

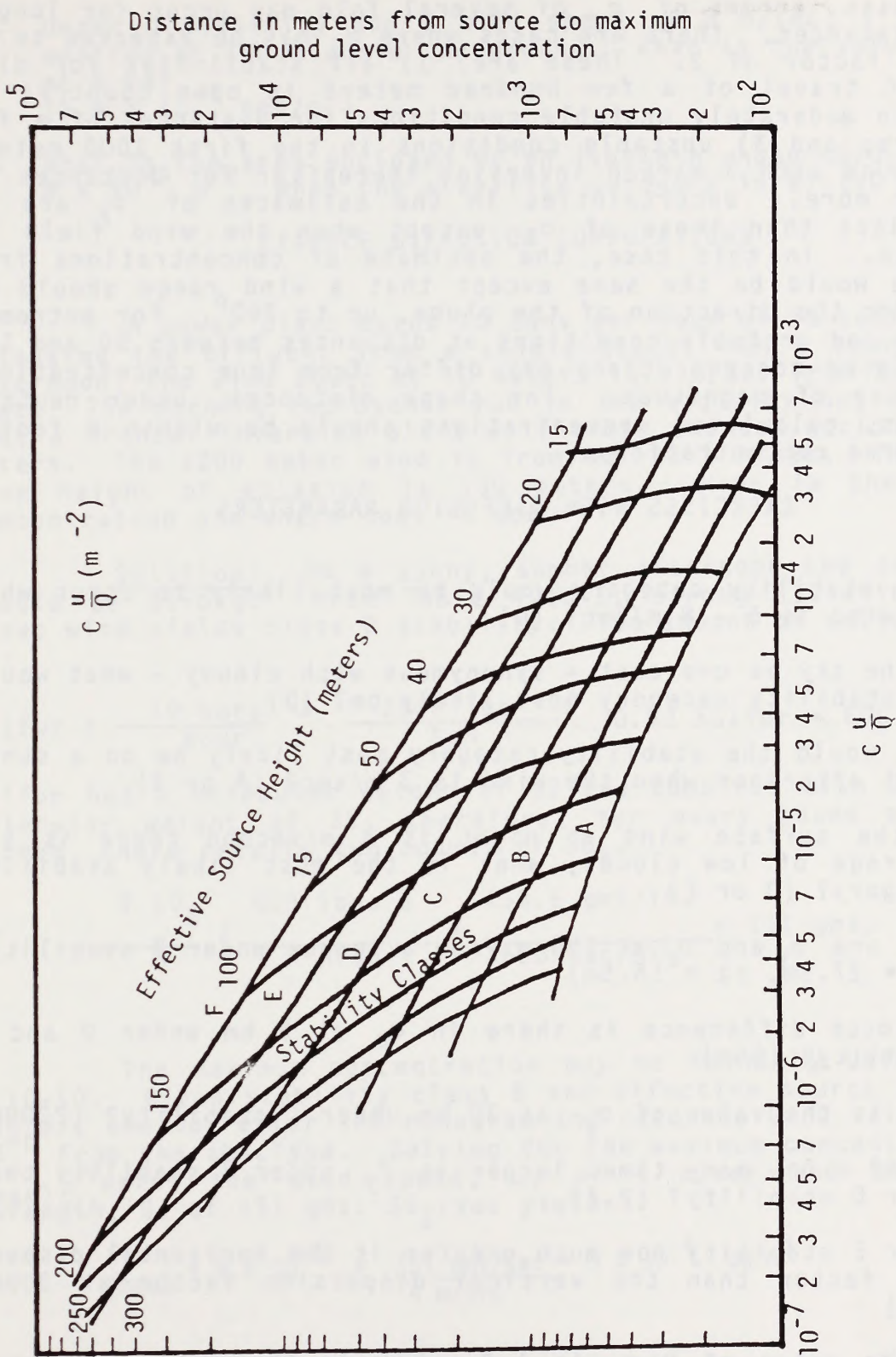

Figure 4.10-10
 Distance from Source and Relative Value of Maximum Concentrations for
 Various Source Heights and Stability Classes

1 meter = 39.37 inches

obtained from Figures 4.10-3 and 4.10-4. In the unstable and stable cases, errors of σ_z of several fold may occur for longer travel distances. There are cases where σ_z may be expected to be within a factor of 2. These are: 1) all stabilities for distances of travel of a few hundred meters in open country; 2) neutral to moderately unstable conditions for distances of a few kilometers; and 3) unstable conditions in the first 1000 meters above ground with a marked inversion thereafter for distances of 10 km or more. Uncertainties in the estimates of σ_y are in general less than those of σ_z except when the wind field is indefinite. In this case, the estimate of concentrations from the plume would be the same except that a wind range should be allowed for the direction of the plume, up to 360° . For extremes of stable and unstable conditions at distances between 50 and 100 km calculated concentrations may differ from true concentrations by an order of magnitude. For these distances, under neutral conditions, calculated concentrations should be within a factor of 5 of true concentrations.

EXERCISES WITH DIFFUSION PARAMETERS

1. What stability category would be most likely to occur when the wind is 6 - 8 m/sec? (D)
2. If the sky is overcast - synonymous with cloudy - what would the stability category most likely be? (D)
3. What would the stability category most likely be on a sunny April afternoon when the wind is 3 m/sec? (A or B)
4. If the surface wind at night is 3 m/second there is 5/8 coverage of low clouds, what is the most likely stability category? (D or E)
5. What are σ_y and σ_z at 150 m from a source under B stability? ($\sigma_y = 27.5\text{m}$, $\sigma_z = 15.5\text{m}$)
6. How much difference is there in σ_z at 5 km under D and F stability? (55m)
7. What is the value of σ_y at 30 km under C stability? (2200m)
8. At 300 m how many times larger is σ_y under B stability than under D stability? (2.4)
9. Under E stability how much greater is the horizontal dispersion factor than the vertical dispersion factor at 300m? (7.7)
10. If the value of H/σ_z is 1.8, what is the value of $\exp - 1/2 (H/\sigma_z)^2$? (1.6)
11. The value of $\exp - 1/2(H/\sigma_z)^2$ is 2.2×10^{-3} . What is H/σ_z ? (3.49)

12. Under D stability and a wind speed of 5 m/sec, a plume is emitted at 100 m above the ground. What is the value of C/Q at 4 km?
(1.4×10^{-6} sec/m³)
13. What is the area enclosed by an isopleth whose Cu/Q₄ value is 4×10^{-4} m⁻², when the stability category is B? (10⁴ m²)

EXAMPLE DIFFUSION COMPUTATIONS

#1 A power plant burns 10 tons per hour of 3% sulfur coal, releasing the effluent from a single stack. On a sunny summer afternoon, the wind speed at 10 meters is 4 m/sec from the north-east. The morning radiosonde run in the vicinity has indicated that a frontal inversion aloft will limit the convection to 1500 meters. The 1200 meter wind is from 30° at 5 m/sec. The effective height of emission is 150 meters. What is the maximum concentration and where does it occur?

Solution: On a sunny, summer afternoon the insolation should be strong. From Table 4.10-1, strong isolation and 4 m/sec wind yields class B stability. The amount of sulfur burned is:

$$\text{Sulfur} = \frac{10 \text{ tons}}{\text{hour}} \times \frac{2000 \text{ lbs}}{\text{ton}} \times 0.03 \text{ sulfur} = 600 \text{ lbs/hr.}$$

Sulfur has a molecular weight of 32 and combines with O₂ with a molecular weight of 32; therefore, for every pound of sulfur burned, there results two pounds of SO₂.

$$Q = \frac{2 \text{ SO}_2}{\text{S}} \times \frac{600 \text{ lbs. S}}{\text{hr.}} \times \frac{453.6 \text{ gms/lb.}}{3600 \text{ sec/hr}} = 151 \text{ gms. SO}_2^2/\text{sec.}$$

The maximum concentration may be found by using Figure 4.10-10. Given stability class B and effective source height of 150 m., one may enter the nomogram and read the Cu/Q value of 8×10^{-6} from the abscissa. Solving for the maximum concentration, C (max), using the wind speed, u, of 4 m/sec and the source strength, Q, of 151 gms. SO₂/sec yields.

$$C (\text{max}) = 8 \times 10^{-6} \times \frac{151 \text{ gms/sec}}{4 \text{ m/sec}} = 3 \times 10^{-4} \text{ gm/m}^3$$

The distance from the power plant at which the maximum concentration occurs under these meteorological conditions can be read from the ordinate in Figure 4.10-10. This distance is 1000m.

#2 Using the conditions in the above problem, draw a graph of centerline sulfur dioxide concentrations beneath the plume with distance from 100 meters to 100 km.

Solution: Since the frontal inversion limits the convection to $h_1 = 1500$ meters, the distance where $\sigma_z = 0.47 h_1 = 700$ meters is $x_1 = 5.5$ km. At distances equal to or greater than $2 x_1 = 11.0$ km, $\sigma_z = 0.8 h_1 = 1200$ meters. Equation 4.10-7 is used to find concentration as a function of distance.

$$C = \frac{151}{\pi u \sigma_y \sigma_z} \exp - \frac{1}{2} \frac{H^2}{\sigma_z^2}$$

In this case $H = 150$ meters. Solutions for this equation are given in Table 4.10-4. The values of concentrations in Table 4.10-4 are plotted against distance in Figure 4.10-11.

#3 Draw a graph of concentration versus cross-wind distance at a downwind distance of 800 meters for the conditions of problems 1 and 2.

Solution: From problem 2, the centerline concentration at 800 meters is 2.9×10^{-4} gms/m³. To determine the concentrations at distances y from the x axis, the centerline concentration must be multiplied by the factor $\exp -1/2(y/\sigma_y)^2$. $\sigma_y = 120$ meters at $x = 800$ meters. Values for this computation are given in Table 4.10-5.

The preceding exercises illustrate one of the simplest approaches to air quality modeling. Numerous levels of sophistication can be incorporated into the basic Gaussian modeling approach to determine pollution concentrations at downwind receptor locations. As mentioned before, the next level incorporates mathematical simulations of plume rise. Plume rise is mainly a function of momentum and thermal buoyancy. Terms related to one or both of these factors are included in nearly all plume rise formulas. For cold stacks (JETS), those with emissions of less than 10 to 20°F above ambient, momentum is probably the most important factor. On the other hand, for hot stacks, when gases are warmer than 200°F, buoyancy is the most important aspect of the plume rise formula. Numerous plume rise formulas have been proposed by a multitude of qualified investigators. No one formula provides the best estimate for all types of stacks and atmospheric conditions. The most widely accepted plume rise formulas were derived by Holland (1953) and Briggs (1969). The basics of their plume rise simulation formulae are applied by most Environmental Protection Agency (EPA) accepted air quality models.

Table 4.10-4
Solutions for Problem #2

Col. a	Col. b	Col. c	Col. d	Col. e	Col. f	Col. g
x (km)	u (m/sec)	σ_y m	σ_z m	H/σ_z	$\exp - \frac{1}{2} \left(\frac{H}{\sigma_z} \right)^2$	C gms/m ³
0.3	4	52	30	5.0	3×10^{-6}	2.3×10^{-8}
0.5	4	77	53	2.83	1.7×10^{-2}	5.0×10^{-5}
0.8	4	120	93	1.61	0.27	2.9×10^{-4}
1	4	150	125	1.20	0.48	3.1×10^{-4}
2.8	4.5	375	700	0.21	0.98	4.0×10^{-5}
5.6	4.5	700	1200	0.125	0.98	1.25×10^{-5}
10	4.5	1200	1200	0.125	0.98	7.3×10^{-6}
100	4.5	8400	1200	0.125	0.98	1.04×10^{-6}

Col. c from Figure 4.10-4

Col. d from Figure 4.10-3

Col. e 150 m over value in Col. d

Col. f Value in Table 4.10-2 corresponding to H/σ_z in Col. e

Col. g Solution to equation 4.10-7

Table 4.10-5

y (m)	y/σ_y	$\exp - \frac{1}{2} (y/\sigma_y)^2$	C(y) gms/m ³
+ 100	0.834	0.7	2.03×10^{-4}
+ 200	1.67	0.25	7.25×10^{-5}
+ 300	2.5	4.2×10^{-2}	1.22×10^{-5}
+ 400	3.33	3.7×10^{-3}	1.07×10^{-6}

This is graphed in Figure 4.10-12

1 m = 3.281 feet
 1 km = 0.6214 miles
 1 m/s = 3.281 feet/second
 1 gm/m³ = 6.243×10^{-7} lbs/feet³

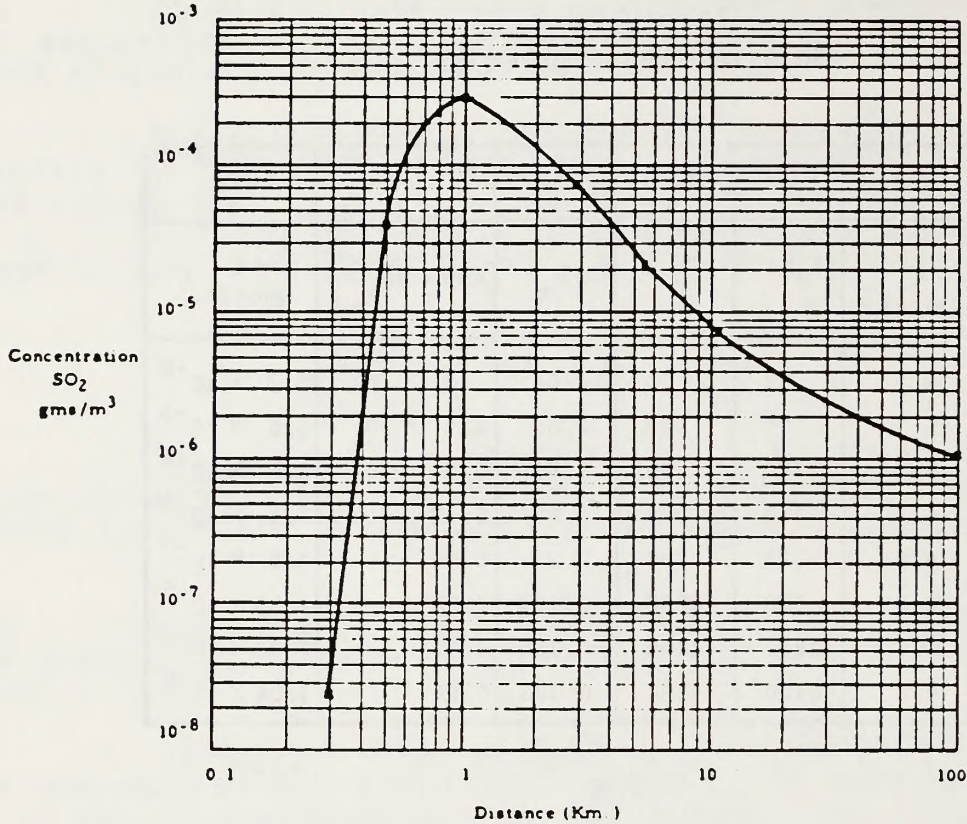

Figure 4.10-11
 Concentration of SO₂ (gm/m³) as a Function of Distance
 (km). (Problem 2)

$$1 \text{ gm/m}^3 = 6.243 \times 10^{-7} \text{ lbs/ft}^3$$

$$1 \text{ km} = 0.6214 \text{ mi}$$

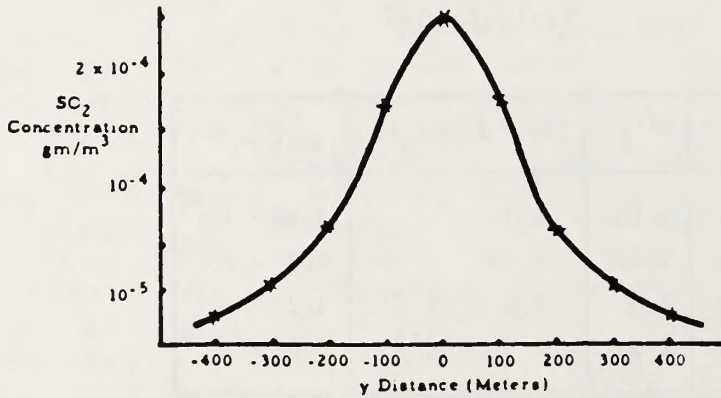

Figure 4.9-12
 Concentration of SO₂ (gm/m³) Across Wind at a Distance of 800 Meters
 (Problem 3)

$$1 \text{ gm/m}^3 = 6.243 \times 10^{-7} \text{ lbs/ft}^3$$

$$1 \text{ m} = 1.094 \text{ yds}$$

Briggs in his recent publication, Plume Rise (1969), has presented both a critical review of the subject and a series of equations applicable to a wide range of atmospheric and emission conditions. These equations are being employed by an increasing number of meteorologists and are used almost exclusively within EPA. An important result of this study is that the rise of buoyant plumes from fossil-fuel plants with a heat emission of 20 megawatts (MW) - 4.7×10^6 cal/sec - or more can be calculated from the following equations under neutral and unstable conditions.

$$\Delta H = 1.6 F^{1/3} u^{-1} x^{2/3} \quad 4.10-8$$

$$\Delta H = 1.6 F^{1/3} u^{-1} (10 h_s)^{2/3} \quad 4.10-9$$

where:

ΔH = plume rise

F = buoyancy flux

u = average wind at stack level

x = horizontal distance downwind of the stack

h_s = physical stack height

Equation 4.10-8 should be applied out to a distance of $10 h_s$ from the stack and equation 4.10-9 can be used for greater distances.

The buoyancy flux term, F , may be calculated from:

$$F = \frac{g Q_H}{\pi c_p \rho T} \approx 3.7 \times 10^{-5} \frac{m^4/sec^3}{cal/sec} Q_H \quad 4.10-10$$

where:

g = gravitational acceleration

Q_H = heat emission from the stack, cal/sec

c_p = specific heat of air at constant pressure

ρ = average density of ambient air

T = average temperature of ambient air

Alternatively, if the stack gases have nearly the same specific heat and molecular weight as air, the buoyancy flux may be determined from:

$$F = \frac{\Delta T}{T_s} g v_s r^2 \quad 4.10-11$$

Notation has been previously defined.

In stable stratification, equation 4.10-8 holds approximately to a distance $x = 2.4 u s^{-1/2}$. S may be defined as a stability parameter:

$$s = \frac{g}{T} \frac{\partial \theta}{\partial z} \quad 4.10-12$$

where:

$$\frac{\partial \theta}{\partial z} = \text{lapse rate of potential temperature}$$

Beyond this point the plume levels off at about

$$\Delta H = 2.4 \left(\frac{F}{u s} \right)^{1/3} \quad 4.10-13$$

However, if the wind is so light that the plume rises vertically, the final rise can be calculated from:

$$\Delta H = 5.0 F^{1/4} s^{-3/8} \quad 4.10-14$$

For other buoyant sources, emitting less than 20 MW of heat, a conservative estimate will be given by equation 4.10-8 up to a distance of:

$$x = 3x^* \quad 4.10-15$$

where:

$$x^* = 0.52 \left[\frac{\text{sec}^{6/5}}{\text{ft.}^{6/5}} \right] F^{2/5} h_s^{3/5} \quad 4.10-16$$

which is the distance at which atmospheric turbulence begins to dominate entrainment.

Sophisticated modeling more complex than the simple Gaussian are often required. These sophisticated algorithms applied to the basic Gaussian approach include the computation of downwind ground level concentrations as a function of stability class and wind speed. Such an approach would incorporate wind speeds as a function of stability class. Further sophistication in the Gaussian modeling approach would incorporate relative frequency distributions of wind speeds, wind direction and stability class. This type of model would be useful in isolating long-term air pollution concentrations in the study area.

There is a limitless number of levels of sophistication with regard to the Gaussian model. The accuracy and refinement of each generation of the model depends upon the quality and

resolution of the data base used. As the problem becomes more complex, more sophisticated numerical models must be employed particularly in instances where terrain or conversion effects become important. Such modeling is beyond the scope of this document, however the EPA may be contacted for more information on dispersion models such as the Climatological Dispersion Model (CDM), the Air Quality Display Model (AQDM), the Valley Model, and the Texas Climatological Model (TCM).

4.11 ASSISTANCE IN DISPERSION METEOROLOGICAL PROBLEMS

References

o Abstracts

Meteorological and Geostrophysical Abstracts
American Meteorological Society
45 Beacon Street
Boston 8, Mass.

o Periodicals

Bulletin of the American Meteorological Society
American Meteorological Society (See above)

Journal of Applied Meteorology
American Meteorological Society

Journal of the Atmospheric Sciences (formerly
Journal of Meteorology)
American Meteorological Society

Monthly Weather Review
U.S. Dept. of Commerce
Weather Bureau, Washington, D.C.

Quarterly Journal of the Royal Meteorological
Society
Royal Meteorological Society
49 Cromwell Road
London, S.W. 7

o Books

American Meteorological Society, On Atmospheric
Pollution,
Meteorological Monographs, 1, 4, Nov. 1951.

Geiger, R. (Transplanted by Scripta Technica Inc.)
The Climate Near the Ground.
Rev. ed., Harvard University Press
Cambridge, Mass. 1965.

Professional Meteorological Consultants

Professional meteorologists advertise their services in the Professional Directory section of the Bulletin of the American Meteorological Society. In the May 1979 Bulletin, 83 such firms and individuals were listed. The American Meteorological Society has in the last several years instituted a program of certifying consulting meteorologists. Of the 83 professional services listings in the Bulletin, 40 list Certified Consulting Meteorologists.

Local U.S. National Weather Service Office

A wealth of meteorological information and experience is available at the local city or airport Weather Service Office pertaining to local climatology, peculiarities in local micro-meteorological conditions including topographic effects, and exposure and operating characteristics of meteorological instruments. The Air Stagnation Advisories are received here by teletype from the National Meteorological Center. Often the public telephones the Weather Service with air pollution complaints which the meteorologists may have traced back to a specific source by examining local wind circulations. Through personal contact with the meteorologist-in-charge (MIC), specific, localized forecasts may be arranged to support a short-term air pollution investigation or sampling program.

Contract Work

Many universities do contract work for private organizations and for government agencies on meteorological problems.

4.12 GLOSSARY OF TERMS

Adiabatic	A thermodynamic change of state of a system in which there is no transfer of heat or mass across the boundaries of the system. In an adiabatic process, compression always results in warming, expansion in cooling.
Adiabatic Diagram	A thermodynamic diagram with temperature as abscissa and pressure to the power 0.286 as ordinate, increasing downward.
Advection Inversion	A type of inversion which occurs over an area due to the horizontal transport of a stable layer (e.g., marine inversion noted along coastal California are the result of the advection of cool, stable air from the nearby Pacific.
Aerodynamic	Pertaining to forces acting upon any moving solid or liquid body other than a stationary object relative to a gas. (especially air).
Air Basin	An area created by topographic boundaries which serves to contain air pollutants emitted into the area by pollution sources and to restrict air exchange with other air basins.
Air Flow Pattern	The typical movement of air currents as graphed on wind roses.
Air Parcel	An imaginary body of air to which may be assigned any or all of the basic dynamic and thermodynamic properties of atmospheric air.
Algorithm	A procedure for solving a problem (as in mathematics) that frequently involves repetition of an operation.
Backing	According to general internationally accepted usage, a change in wind direction in a counterclockwise sense.
Bimodal	A distribution having two maxima.
Black Body	A body which absorbs all incident electromagnetic radiation; i.e., one which neither reflects nor transmits any incident radiation.
Buoyancy Flux	An empirical term used in plume rise calculations to define the heat content of an industrial source.

Burn/No-Burn	Used to determine when weather conditions forecasts favor the rapid dispersion of pollutants created by the burning of agricultural wastes and other industrial operations.
Calm	A period when the air is motionless. In the United States, the wind is reported as calm if it has a speed of less than one mile per hour (or one knot).
Centerline Concentration	The concentration of gaseous pollutants or aerosols at the center of the plume.
Channeling	The effect of terrain, particularly valleys, in modifying the prevailing winds along the path of lowest terrain heights.
Cold Stacks (Jets)	Cold, non-buoyant sources with emission temperatures less than 10 to 20°F above ambient temperatures.
Condensation Levels	The level at which a parcel of moist air lifted dry adiabatically would become saturated.
Coning	When the vertical temperature gradient is between dry adiabatic and isothermal, slight instability occurs with both horizontal and vertical mixing. An industrial plume tends to become cone shaped, hence the name.
Constant Level Balloons	A balloon designed to float at a constant pressure level.
Convective Thundershowers	Showers caused when layers of air are forced to rise rapidly.
Diffusion	In meteorology, the exchange of fluid parcels between regions in space, in the apparently random motions of a scale too small to be treated by the equations of motion.
Digitized Data	Data which is recorded in a computer acceptable format (as opposed to analog or strip chart data).
Dispersion Modeling	The mathematical representation or simulation of transport processes that occur in the atmosphere.
Dispersion Potential	The ability of a system such as the atmosphere, to dilute the concentration of a substance or pollutant by molecular and turbulent motion; e.g., smoke in the air.

Diurnal	Daily, especially pertaining to actions which are completed within twenty-four hours and which recur every twenty-four hours.
Downwash	The condition resulting when strong winds push a plume rapidly to the surface, resulting in high ground-level pollution concentrations. The phenomenon is usually observed in the lee of buildings.
Drainage Flow	The movement of cold air off high ground, caused by gravity and typical of mountainous regions.
Dry Adiabatic Rate	The rate of decrease of temperature with lapse height when dry air is lifted adiabatically (due to expansion as it is lifted to lower pressure).
Effective Stack	The physical stack height plus plume rise, i.e., the point above ground at which the gaseous effluent becomes essentially level.
Elevated Inversion	An inversion layer above the immediate surface. Such an inversion inhibits dispersion of buoyant pollutants, such as those given off by power facilities and refineries.
Empirical	An approach based upon observation and experimentation.
Environmental Lapse Rate	The actual rate of decrease of temperature with elevation at a given time and place.
Exit Characteristics	Parameters pertaining to a gas exiting from a stack including gas temperature, exit velocity, emission rate, stack height, and stack diameter.
Fanning	When the atmosphere is stably stratified, an industrial plume will spread horizontally but little if any vertically.
Fire Management	The practice of controlling range undergrowth, such as chaparral, through controlled burning.
Fire Weather	The state of the weather with respect to its effect upon the kindling and spreading of forest fires.
Fluid Dynamics	The level of physics that treats the action of force on fluids and gases in motion or at rest.

Freezing Level	The lowest altitude in the atmosphere over a given location at which the air temperature is 32°F.
Front	The transition zone between two air masses of different density.
Frontal Inversion	A temperature inversion encountered in the atmosphere, upon vertical ascent through a sloping front.
Fugitive Dust	Solid air borne particles emitted from any source other than a stack.
Fugitive Source	A source emitting pollutants other than from a stack.
Fumigation	The rapid mixing of a fanning plume down to the ground, such as during inversion breakup.
Gaussian Diffusion Equation	An equation used to evaluate the concentration of gases or aerosols assuming a Gaussian or normal distribution.
Horizontal Dispersion Coefficient	The horizontal standard deviation of plume pollutant concentration. The parameter varies as a function of downwind distance and atmospheric stability.
Induced Flow	A flow of air caused by uneven heating of terrain and its associated air parcels.
Insolation	Solar radiation received at the earth's surface.
Inversion	A departure from the usual decrease or increase with altitude of the value of an atmospheric property (almost always of temperature). In a temperature inversion, temperature increases with altitude. A temperature inversion is stable, allowing little turbulent exchange to occur.
Inversion Layer	That layer of air which departs from the usual decrease in temperature with increasing altitude.
Isopleth	A line of equal or constant value of a given quantity, with respect to either space or time.
Isothermal	Of equal or constant temperature, with respect to either space or time.

Jet (Low-Level)	A high-speed wind that attains its velocity through channeling due to terrain configuration such as a narrow mountain pass or canyon.
K-Theory	K-theory or gradient transport theory assumes that turbulent diffusion is proportional to the local mean concentration gradient.
Land Breeze	A coastal breeze blowing from land to sea, caused by the temperature difference when the sea surface is warmer than the adjacent land.
Lapse Rate	The decrease of an atmospheric variable (almost always temperature) with height.
Line Source	A source of pollutants occurring at a reasonably continuous rate along a fixed line (e.g., highway).
Lofting	Lofting of an industrial plume occurs when there is a superadiabatic layer above a surface inversion. It is a condition which encourages diffusion upward but not downward because of the presence of a stable layer below.
Looping	The looping of an industrial plume occurs with a superadiabatic lapse rate.
Mixing Height/ Depth	Height (Depth) of the layer of air where well-mixed conditions exist, usually the height of the first significant inversion above the surface.
Mixing Layer	That thin layer of the troposphere available for the dispersion of pollutants released near the surface.
Momentum Exchange	The turbulent transfer of momentum; the product of mass and velocity.
Mountain Flow	The regular flow of air around portions of raised terrain. Air will stream toward and up mountain slopes during the day and downward and away during the night.
Neutral Atmospheric Stability	Neutral stratification of the atmosphere, i.e., the lapse rate is equal to the dry-adiabatic lapse rate, therefore, a parcel of air displaced vertically will experience no buoyant acceleration.

Nocturnal Air Flow	A flow pattern characteristic of clear nights and rapid radiational cooling, which tends to stabilize the atmosphere promoting air flow from higher terrain towards low lying areas.
Nucleation	The condensation out of molecules on airborne particles.
Numerical Modeling	The development of a means of computing the future state of the atmosphere from the basic theoretical equations which govern that state.
Orographic	Of, pertaining to, or caused by mountains.
Pasquill's Stability Categories	Stability classes as defined by Dr. F. Pasquill of the British Meteorological Service, including extremely unstable, unstable, slightly unstable, neutral, slightly stable, and stable.
Persistence	Time period over which a certain parameter is maintained.
Physical Modeling	Physical modeling is based upon the actual simulation of events in the real atmosphere or in a scale model.
Physical Stack Height	Actual height of a stack, i.e., a pollutant source.
Plume	A large, conspicuous cloud of smoke, dust, or water vapor arising from a stack.
Plume Rise	The velocity and heat of an industrial source will cause it to rise to a certain height. The difference between this height and the physical stack height is called plume rise.
Positive Net Radiation	Amount of incoming solar radiation in excess of outgoing terrestrial radiation.
Prevailing Wind(s)	The wind direction(s) most frequently observed during a given period.
Profile	A graph of the value of a scalar quantity (such as temperature) versus a horizontal, vertical, or time scale.
Pseudo-Adiabatic Rate	The rate of decrease of temperature with Lapse height of an air parcel lifted at saturation through the atmosphere. Less than the dry adiabatic lapse rate.

Radiational Cooling	Cooling of the earth's surface and surrounding air accomplished (mainly at night) whenever the earth's surface experiences a net loss of heat.
Radiational Inversion	An inversion at the surface due to radiation cooling.
Radiosonde	A balloon-borne instrument used for measuring and transmitting weather data, such as pressure, temperature and humidity.
Re-entrainment	The mixing of environmental air into an organized air current of which it formally was a member.
Regime	The character of the seasonal distribution of a weather phenomenon at any place; e.g., the summer sea breeze regime.
Screening Level	A simplistic approach designed to determine the need for additional, more detailed analyses.
Sky Cover	The amount of sky covered or concealed by clouds or other obscuring phenomena.
Slope Winds	Winds caused by uneven surface heating and cooling in areas of rugged terrain.
Smoke Sensitive Area	An area which, due to high population density, recreational value or scenic beauty, is considered particularly sensitive to smoke plumes from forest management burning.
Solar Altitude	The elevation angle of the sun above the horizon.
Solar Insolation	Solar radiation received at the earth's surface.
Sorption	The deposition of molecules due to collision with an object.
Sounding	Any penetration of the natural environment for scientific observation. In meteorology, commonly refers to the environmental lapse rate.
Stability	A measure of the extent to which vertical and horizontal mixing will take place. Commonly measured as unstable, neutral or stable.
Stable	The lapse rate is less than the dry adiabatic lapse rate and vertical motion is suppressed.

STAR (<u>S</u> tability <u>A</u> rRay)	A description of a type of meteorological program developed by the National Climatic Center in Asheville, North Carolina. The program provides joint frequency distributions of wind speed, wind direction, and atmospheric stability class.
Stability Wind Roses	Diagrams designed to show the distribution of wind direction experienced at a given location over a desired time period for a given atmospheric stability class.
Stack	Any chimney, flue, conduit, or duct arranged to conduct emissions to the outside air.
Statistical Modeling	Statistical modeling is based upon the stochastic nature of turbulence and describes diffusion as an ensemble average of many particles emitted from a source.
Sub-Adiabatic	A lapse rate which is less than the dry adiabatic lapse rate (5.5°F per 1,000 feet).
Subsidence Inversion	A temperature inversion produced by the warming of a layer of descending air. The effect is the creation of a limited mixing volume below the stable layer.
Super-Adiabatic	A lapse rate which is greater than the dry adiabatic lapse rate.
Surface Based Inversion	An inversion layer of stable air close to the ground. Such an inversion inhibits dispersion of fugitive dust and other non-buoyant sources of pollutants.
Surface Boundary Layer	The thin layer of air immediately adjacent to the earth's surface.
Surface Data	Observations of the weather from a point at the surface of the earth, as opposed to upper-air or winds-aloft observations.
Surface Roughness	Irregularities of the earth's surface (provided by trees, buildings, etc.) which increases air turbidity, and consequently, pollutant dispersion.
Synoptic Scale Winds	Strong winds created by weather patterns of high and low pressure systems in: the lower troposphere.

Temperature Profile	A graph of temperature versus a horizontal, vertical, or time scale.
Temperature Sounding	Upper-air observations of temperature as taken by a radiosonde.
Thermal Buoyancy	The impetus provided by heat for an emission to rise or remain suspended in the atmosphere.
Thermal Low	An area of low atmospheric pressure due to high temperatures caused by intensive heating at the earth's surface.
Transport	The rate by which a substance or quantity, such as heat, suspended particles, etc., is carried past a fixed point.
Trapping	When an inversion occurs aloft such as a frontal or subsidence inversion, a plume released beneath the inversion will be trapped beneath it.
Trajectory Analyses	The depiction of regional wind direction patterns at the surface of the earth, as generated from the most frequent wind direction occurring at each of several stations in an area for selected averaging periods.
Tropopause	The boundary between the troposphere and the stratosphere.
Troposphere	The lowest 10 to 20 km (6-12 miles) of the atmosphere. It is characterized by decreasing temperature with height, appreciable vertical wind motion, appreciable water vapor content, and weather.
Typical Conditions	The most commonly occurring combination of the key dispersion factors - wind speed, wind direction, and atmospheric stability class. Knowledge of the most commonly occurring dispersion conditions provides some indication of the effect of an existing or proposed pollution source.
Unstable	The environmental lapse rate is greater than the dry adiabatic lapse rate and vertical turbulence is enhanced.
Valley Winds	A wind which ascends a mountain valley during the day.
Veering	According to general international usage, a change in wind direction in a clockwise sense.

Ventilate	To cause to circulate as in the dispersion of air pollutants.
Vertical Circulation	The movement or mixing of air along a vertical axis.
Vertical Dispersion Coefficient	The vertical standard deviation of plume pollutant concentration. The parameter varies as a function of downwind distance and atmospheric stability.
Vertical Temperature Profile	A graph of temperature versus altitude.
Vertical Wind Profile	A graph of the variation of mean wind speed with height in the surface boundary layer.
Virtual Source	The theoretical location of a point source with respect to an actual area source which would result in plume dispersion at the actual point of emission indicative of the area source.
Wind Tunnel	A small scale model of the atmosphere which permits experimentation in the laboratory.
Winds Aloft	Wind speeds and directions at various levels in the atmosphere above the surface.
Worst-case Conditions	That combination of wind speed, wind direction, and atmospheric stability class that would result in the greatest possible pollutant impact of an existing or proposed source.

BIBLIOGRAPHY

- Argonne National Laboratory, "Report to the USEPA on the Specialists Conference on EPA Modeling Guidelines", Energy and Environmental Systems Division, Chicago, Illinois, February, 1977.
- Briggs, G.A., Some Recent Analyses of Plume Rise Observations. pp. 1029-1032 in Proceedings of the Second International Clean Air Congress. Ed. by H.M. Englund and W.T. Berry. Academic Press, New York. 1971.
- California Air Resources Board, "Climate of the Sacramento Valley Air Basin", undated.
- Church, P.E.; "Dilution of Waster Stack Gases in the Atmosphere", Ind. Eng. Chem. 41, 12, 2753-2756, Dec. 1949.
- Court, A. Wind Roses. Weather, 18: 106-110. April 1963.
- Estoque, M.A. "The Sea Breeze as a Function of the Prevailing Synoptic Situation". Meteorology Division, Univ. of Hawaii, Scientific Report No. 1, Contract No. AF 19(604)-7484, October, 1961.
- Franson, Gary, "A Study of the Inversion and Mixing Heights at Fresno, Ca.", undated.
- Gifford, F.A., Jr. Uses of Routine Meteorological Observations for Estimating Atmospheric Dispersion. Nuclear Safety. 2:4. 1961.
- Hewson, E.W.; Bierly, E.W.; and Gil, G.C. "Topographic Influences on the Behavior of Stack Effluents". Proceedings of the American Power Conference, 23, 358-370, 1961.
- Hewson, E.W.; "Meteorological Measuring Techniques and Methods for Air Pollution Studies" in Industrial Hygiene and Toxicology, Vol. 3. L. Silverman (Ed.) New York, Interscience.
- Hilsmeier, W.F., and Gifford, F.A., Jr. Graphs for Estimating Atmospheric Diffusion, ORO-545, Atomic Energy Commission. Oak Ridge, Tennessee. 1962. 10pp.
- Holland, J.Z. A Meteorological Survey of the Oak Ridge Area. AEC, Washington, Report ORO-99. 554-559, 1953.
- Holzworth, G.C., "Is Valley Weather Conducive to Air Pollution," 1978.

- Holzworth, G.C. Mixing Heights, Wind Speeds, and Potential for Urban Air Pollution Throughout the Contiguous United States. OAP, Publication No. AP-101, January 1972.
- List, R.J. Smithsonian Meteorological Tables. Sixth Revised Edition. 497-505. Smithsonian Institution, Washington, D.C. 1951.
- Pasquill, F. Atmospheric Diffusion, Van Nostrand, London, 1962.
- Pasquill, F. The Estimation of the Dispersion of Windborne Material. The Meteorological Magazine. 90: 1063. 33-49. 1961.
- Samuel J. Williamson, "Fundamentals of Air Pollution", Addison Wesley Publishing Co., Reading, Massachusetts, 1973.
- Science Applications, Inc., "Air Quality Models, Required Data Characterization", Prepared for Electric Power Research Institute by Westlake Village, California, May, 1976.
- Shultz, Richard H., "Notes on Diffusion Modeling", Trinity Consultants, Dallas, Texas, May, 1976.
- Singer, I.A.; and Raynot, G.S. "Analysis of Meteorological Tower Data, April 1950 - March 1952, Brookhaven National Laboratory", AFCRC TR-57-220, Brookhaven National Laboratory, June 1957.
- Sutton, O.G. Micrometeorology, New York, McGraw - Hill p.267, 1953.
- U.S. Atomic Energy Commission, "Meteorology and Atomic Energy, 1968", National Technical Information Service, U.S. Department of Commerce, Springfield, Virginia, 22161.
- U.S. Environmental Protection Agency, "Air Pollution Meteorology", Control Programs Development Division, Research Triangle Park, North Carolina, 1973.
- U.S. Environmental Protection Agency, "Draft - Workbook for the Comparison of Air Quality Models", Monitoring and Data Analysis Division Office of Air Quality Planning and Standards, Research Triangle Park, North Carolina, November, 1977.
- U.S. Environmental Protection Agency, "Air Pollution Meteorology", Control Programs Development Division, Research Triangle Park, North Carolina, 1973.
- U.S. Environmental Protection Agency, "Guidelines Series", OAQPS #1.2-080 October 1977, Office of Air Quality Planning and Standards, Research Triangle Park, North Carolina.

U.S. Environmental Protection Agency, "Some Topics Relating to the Modeling of Dispersion in the Boundary Layer", EPA-650/4-75-015, Office of Research and Development, Washington, D.C., April, 1975.

Yansky, G.R., E.H. Markee, Jr., and A.P. Richter, Climatology of the National Reactor Testing Station, Environmental Science Services Administration (January 1966).

5.0 BASELINE AIR QUALITY EMISSION LEVELS

5.1 FORMATION OF AIR POLLUTANTS

5.1.1 Introduction

Polluted atmospheres generally are associated with man's industrial and domestic activities. However, many of the major gaseous pollutants are also emitted by nature. Taken on a worldwide basis, the total mass of trace gases emitted by nature exceeds those emitted by man by several orders of magnitude. Nonetheless, man's activities do adversely affect the quality of the atmosphere, particularly in dense urban areas and near large emission sources. For many of the pollutants, serious long-term worldwide effects are feared. The effects may be immediate and obvious, such as poor visibility, eye irritation, and objectionable odors; or the effects may be noticeable only through longer periods of observation, such as in corrosion. More subtle effects require sophisticated statistical studies to determine such things as human health effects and changes in the earth's energy balance.

Table 5.1-1 compares typical concentrations of pollutants (Cadle, 1970) with those found in uncontaminated areas. It can be seen that the ratio of concentration of polluted air to clean air ranges from fractional to 1000-fold. Table 5.1-2 by Robinson and Robbins (1972) summarizes the worldwide sources, atmospheric concentrations, residence times, and removal reactions for eight principal gaseous air pollutants. Except for sulfur dioxide, emissions from natural sources exceed those from pollution sources. Figure 5.1-1 and 5.1-2 show the relationship between outdoor and indoor pollution levels for sulfur dioxide and carbon monoxide. Measurements such as these indicate serious penetration into homes near strong pollution sources (Benson, et. al., 1972).

5.1.2 The Gaseous Compounds of Carbon

The gaseous compounds of carbon found in natural and polluted atmospheres comprise a broad spectrum of the compounds of organic chemistry. Because carbon can form bonds with elements such as hydrogen, oxygen, nitrogen, and sulfur and at the same time combine with itself to form a series of straight and branched chain, cyclic, and combined cyclic-chain systems, an almost infinite number of compounds are possible. Many gaseous carbon compounds such as methane (marsh gas), carbon dioxide, carbon monoxide, the terpenes (Table 5.1-3 [Rasmussen, 1972]), and other volatile plant materials are emitted in nature through biological processes, volcanic action, forest fires, natural gas seepage, etc. In areas inhabited by man, the emissions of commerce, industry and transportation are largely concentrated in urban areas and generate high local concentrations of volatile solvents and fossil fuel combustion products.

Table 5.1-1
 Comparison of Trace Gas Concentrations (ppm)

	<i>Clean air</i>	<i>Polluted air</i>	<i>Ratio polluted-to-clean</i>
CO ₂	320	400	1.3
CO	0.1	40-70	400-700
CH ₄	1.5	2.5	1.3
N ₂ O	0.25	(?)	—
NO _x (NO ₂)	0.001	0.2	200
O ₃	0.02	0.5	25
SO ₂	0.0002	0.2	1000
NH ₃	0.01	0.02	2

Table 5.1-2

Summary of Sources, Concentrations, and Major Reactions of Atmospheric Trace Gases

Contaminant	Major pollution sources	Natural sources	Estimated emissions (tons)		Atmospheric background concentrations	Calculated atmospheric residence time	Removal reactions and sinks	Remarks
			Pollution	Natural				
O ₃	Combustion of coal and oil	Volcanoes	146 × 10 ⁶	No estimate	0.2 ppb	4 days	Oxidation to sulfate by ozone or, after absorption, by solid and liquid aerosols	Photochemical oxidation with NO _x and HC may be the process needed to give rapid transformation of SO ₂ to SO ₄
H ₂ S	Chemical processes, sewage treatment	Volcanoes, biological action in swamp areas	3 × 10 ⁶	100 × 10 ⁶	0.2 ppb	2 days	Oxidation to SO ₂	Only one set of background concentrations available
CO	Auto exhaust and other combustion	Forest fires, oceans, terpene reactions	304 × 10 ⁶	33 × 10 ⁶	0.1 ppm	<3 years	Probably soil organisms	Ocean contributions to natural source probably low
NO, NO ₂	Combustion	Bacterial action in soil (?)	53 × 10 ⁶	NO: 430 × 10 ⁶ NO ₂ : 658 × 10 ⁶	NO: 0.2-2 ppb NO ₂ : 0.5-4 ppb	5 days	Oxidation to nitrate after sorption by solid and liquid aerosols, hydrocarbon photochemical reactions	Very little work done on natural processes
NH ₃	Waste treatment	Biological decay	4 × 10 ⁶	1160 × 10 ⁶	6 ppb to 20 ppb	7 days	Reaction with SO ₂ to form (NH ₄) ₂ SO ₄ oxidation to nitrate	Formation of ammonium salts is major NH ₃ sink
N ₂ O	None	Biological action in soil	None	500 × 10 ⁶	0.25 ppm	4 years	Photodissociation in stratosphere, biological action in soil	No information on proposed absorption of N ₂ O by vegetation
Hydrocarbons	Combustion exhaust, chemical processes	Biological processes	88 × 10 ⁶	CH ₄ : 1.6 × 10 ⁶ Terpenes: 200 × 10 ⁶	CH ₄ : 1.5 ppm non CH ₄ : <1 ppb	4 years (CH ₄)	Photochemical reaction with NO, NO ₂ , O ₃ ; large sink necessary for CH ₄	"Reactive" hydrocarbon emissions from pollution = 27 × 10 ⁶ tons
CO ₂	Combustion	Biological decay, release from oceans	1.4 × 10 ¹⁰	10 ¹¹	320 ppm	2-4 years	Biological adsorption and photosynthesis, absorption in oceans	Atmospheric concentrations increasing by 0.7 ppm/year

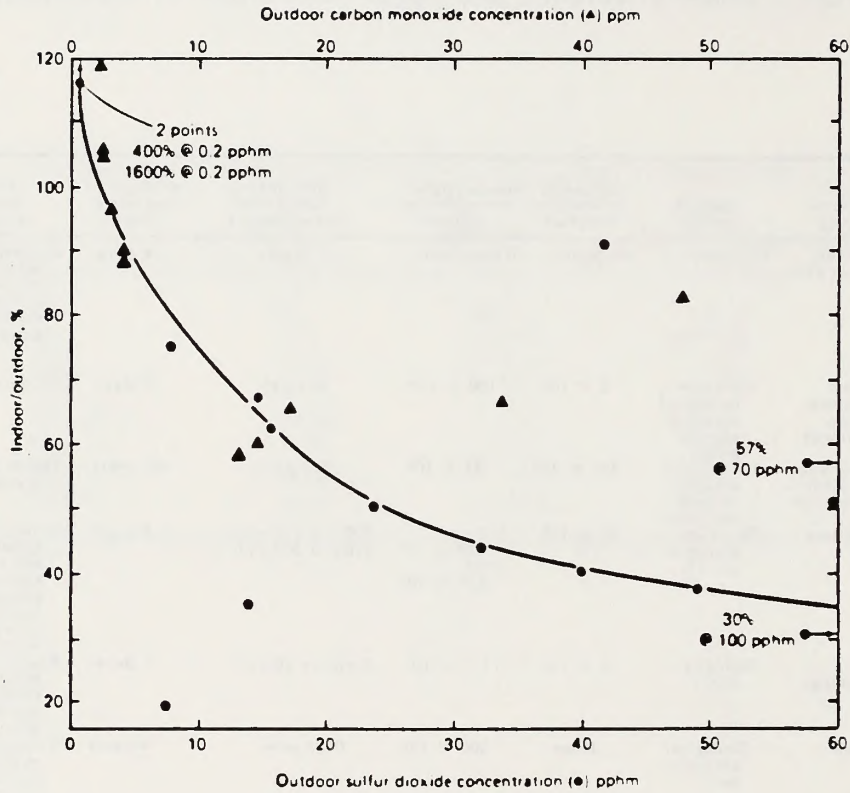

Figure 5.1-1
 Indoor concentrations of sulfur dioxide
 and carbon monoxide as a function of
 outdoor concentrations.

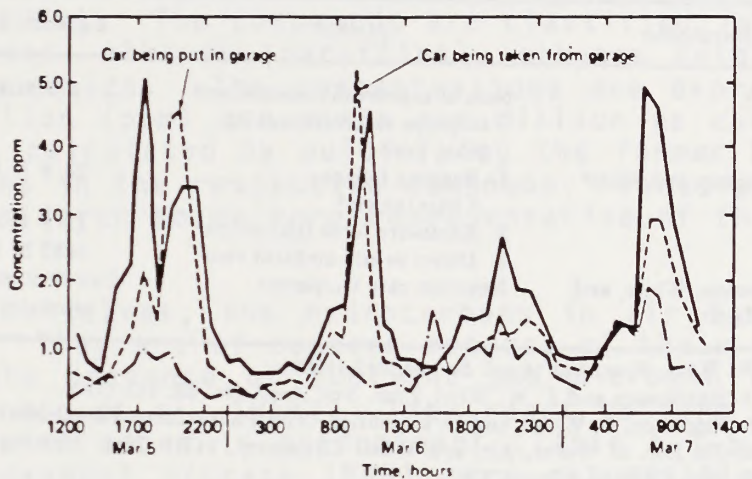

Figure 5.1-2

Carbon monoxide concentrations in house with gas range and furnace and with attached garage. Solid line, kitchen; dashed line, family room; dotdashed line, outside.

Table 5.1-3
Worldwide Terpene Emission Estimates

<i>Investigator</i>	<i>Method</i>	<i>Estimate in tons</i>
Went ^a	Sum of sagebrush emission and terpenes as percentage of plant tissues	175 × 10 ⁴
Rasmussen and Went ^b	1. Bagging foliage 1 liter/10 cm ²	23.4 × 10 ^{4d}
	2. Enclosure forbs 0.65 m ³ /m ³	13.5 × 10 ^{4d}
	3. Direct <i>in situ</i> ambient conc.	432 × 10 ⁴
Ripperton, White, and Jeffries ^c	Reaction rate O ₃ /pinene	2 to 10 × previous estimates

^a F. W. Went, *Proc. Nat. Acad. Sci.* **46**, 212 (1960).

^b R. A. Rasmussen and F. W. Went, *Proc. Nat. Acad. Sci.* **53**, 215 (1965).

^c L. A. Ripperton, O. White, and H. E. Jeffries, "Gas Phase Ozone-Pinene Reactions," pp. 54-56. Div. of Water, Air, and Waste Chemistry, 147th Nat. Meeting Amer. Chem. Soc., Chicago, Illinois, 1967.

^d Not corrected for vertical foliage area over ground area.

Table 5.1-4
Estimates of Hydrocarbon Emissions, 1940-1970 (10⁶ tons/year)
(United States)

<i>Source category</i>	<i>1940</i>	<i>1950</i>	<i>1960</i>	<i>1968</i>	<i>1969</i>	<i>1970</i>
Fuel combustion in stationary sources	1.4	1.3	1.0	1.0	0.9	0.6
Transportation	7.5	11.8	18.0	20.2	19.8	19.5
Solid waste disposal	0.7	0.9	1.3	2.0	2.0	2.0
Industrial process losses	3.3	5.2	4.3	4.4	4.7	5.5
Agricultural burning	1.9	2.1	2.5	2.8	2.8	2.8
Miscellaneous	4.5	4.2	4.4	4.9	5.0	4.4
Total	19.1	25.6	31.6	35.2	35.2	34.7
Total controllable ^a	14.7	21.4	27.2	30.3	30.2	30.3

^a Miscellaneous sources not included.

5.1.2.1 The Hydrocarbons

Table 5.1-4 shows the emissions of hydrocarbons in the United States since 1940 (Cavender et al, 1973). Transportation is by far the principal emitting source, and these data indicate that its emissions seem to have peaked starting in 1968. Table 5.1-5 gives the average concentration for about 30 hydrocarbon compounds identified and measured in Los Angeles, California air (LAAPCD, 1970-72). More than 60 hydrocarbons have been identified, but the total number possible is very large and is limited only by the sensitivity and selectivity of the analytical method used (USEPA, 1970). The compounds are classified into four major functional types: alkanes (paraffins), alkenes (olefins), acetylenes, and aromatics. The concentrations are expressed in both parts per million (ppm) and parts per million as carbon (ppm C). The latter is calculated by multiplying the former by the number of carbon atoms in the respective compound. Parts per million as carbon is considered to be more representative of the hydrocarbon burden of the air.

In themselves, the hydrocarbons in air have relatively low toxicity. They are of concern because of their photochemical activity in the presence of sunlight and nitrogen oxides (Tuesday, 1971; Gordon et al, 1968). They react to form photochemical oxidants of which ozone is predominant (Table 5.1-6). Oxidants, including peroxyacyl nitrate (PAN), are responsible for much of the plant damage and eye irritation associated with smog. Methane has very low photochemical activity. As a consequence, hydrocarbon concentrations are often measured separately as methane on the one hand and non-methane hydrocarbons on the other (Figure 5.1-3). Methane will vary from 40% to 80% of the total hydrocarbons in an urban atmosphere (Figure 5.1-4 (Altshuller et al, 1973)).

Strictly speaking, hydrocarbons are the compounds of hydrogen and carbon. At least two of the techniques used for measuring "total" hydrocarbons in air include many other classes of organic compounds. The nondispersive infrared method (NDIR), for example, measures compounds containing carbon-hydrogen bonds. This includes most organic compounds. The flame ionization method measures anything that reacts to form ions in a hydrogen flame. Pure hydrocarbons give higher specific responses, but without prior separation; the longer chain alcohols, aldehydes, esters, acids, etc., also give responses.

5.1.2.2 The Oxygenated Hydrocarbons

The oxygenated hydrocarbons, like the hydrocarbons, include an almost infinite number of compounds. They are classified as alcohols, phenols, ethers, aldehydes, ketones, esters, peroxides, and organic acids (Roberts and Caserio, 1967).

Some minor amounts of oxygenated hydrocarbons are emitted as solvent vapors from the chemical, paint and plastics

Table 5.1-5
Average Hydrocarbon Composition from
218 Ambient Air Samples Taken in Los
Angeles, California

<i>Compound</i>	<i>Concentration</i>	
	<i>ppm</i>	<i>ppm (as carbon)</i>
Methane	3.22	3.22
Ethane	0.098	0.20
Propane	0.049	0.15
Isobutane	0.013	0.05
<i>n</i> -Butane	0.064	0.26
Isopentane	0.043	0.21
<i>n</i> -Pentane	0.035	0.18
2,2-Dimethylbutane	0.0012	0.01
2,3-Dimethylbutane	0.014	0.08
Cyclopentane	0.004	0.02
3-Methylpentane	0.008	0.05
<i>n</i> -Hexane	0.012	0.07
Total alkanes (excluding methane)	0.3412	1.28
Ethylene	0.060	0.12
Propene	0.018	0.05
1-Butene + isobutylene	0.007	0.03
<i>trans</i> -2-Butene	0.0014	0.01
<i>cis</i> -2-Butene	0.0012	Negligible
1-Pentene	0.002	0.01
2-Methyl-1-butene	0.002	0.01
<i>trans</i> -2-Pentene	0.003	0.02
<i>cis</i> -2-Pentene	0.0013	0.01
2-Methyl-2-butene	0.004	0.02
Propadiene	0.0001	Negligible
1,3-Butadiene	0.002	0.01
Total alkenes	0.1020	0.29
Acetylene	0.039	0.08
Methylacetylene	0.0014	Negligible
Total acetylenes	0.0404	0.08
Benzene	0.032	0.19
Toluene	0.053	0.37
Total aromatics	0.085	0.56
Total	3.7886	5.43

Table 5.1-6
Ozone Levels Generated in Photooxidation of Various
Hydrocarbons with Oxides of Nitrogen

<i>Hydrocarbon</i>	<i>Ozone level, ppm</i>	<i>Time, min</i>
Isobutene	1.00	28
2-Methyl-1,3-butadiene	0.80	45
<i>trans</i> -2-Butene	0.73	35
3-Heptene	0.72	60
2-Ethyl-1-butene	0.72	80
1,3-Pentadiene	0.70	45
Propylene	0.68	75
1,3-Butadiene	0.65	45
2,3-Dimethyl-1,3-butadiene	0.65	45
2,3-Dimethyl-2-butene	0.64	70
1-Pentene	0.62	45
1-Butene	0.58	45
<i>cis</i> -2-Butene	0.55	35
2,4,4-Trimethyl-2-pentene	0.55	50
1,5-Hexadiene	0.52	85
2-Methylpentane	0.50	170
1,5-Cyclooctadiene	0.48	65
Cyclohexene	0.45	35
2-Methylheptane	0.45	180
2-Methyl-2-butene	0.45	38
2,2,4-Trimethylpentane	0.20	80
3-Methylpentane	0.22	100
1,2-Butadiene	0.20	60
Cyclohexane	0.20	80
Pentane	0.18	100
Methane	0.0	—

* Hydrocarbon concentration (initial) 3 ppm; oxide of nitrogen (NO or NO₂, initial) 1 ppm.

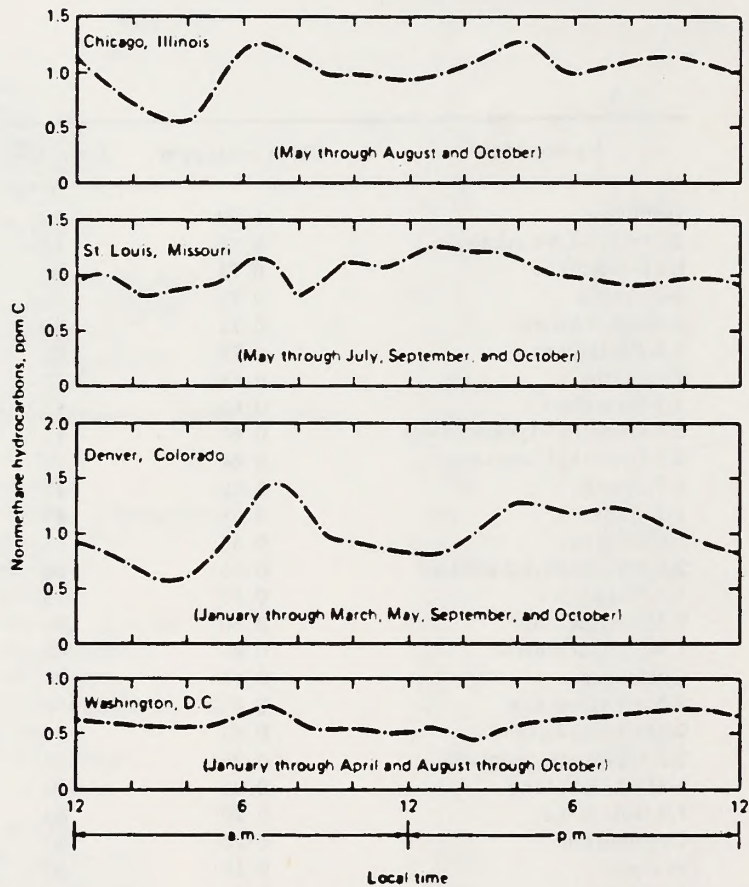

Figure 5.1-3

Nonmethane hydrocarbons as measured by a flame ionization analyzer, averaged by hour of day over several months for various cities.

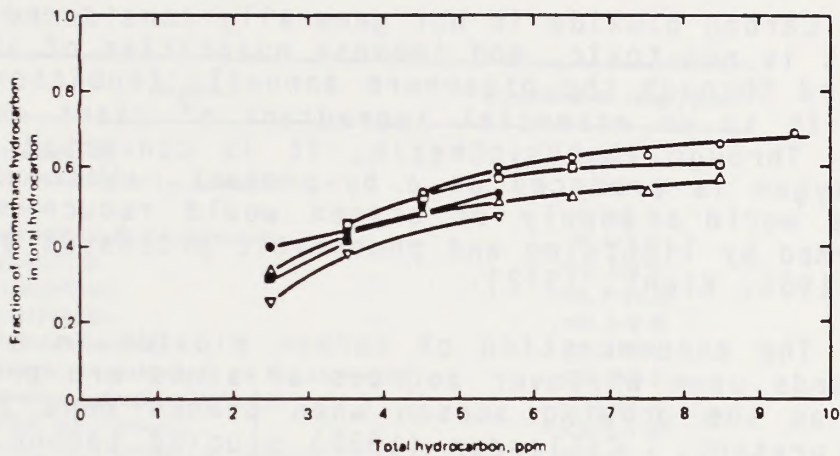

Figure 5.1-4

Nonmethane hydrocarbon fraction to total hydrocarbon for selected locations. ○: Los Angeles, California, 1967; □: Azusa, California, 1967; △: Los Angeles, California, 1968; ▽: Los Angeles, California, 1968---Sundays; ◆: Brooklyn, New York, 1969; ■: Bayonne, New Jersey, 1968

industries. The greater quantities of primary emissions are more usually associated with the automobile. Table 5.1-7 (Seizinger and Dimitriades, 1972) lists some typical oxygenates found in automobile exhaust. The aldehydes are the preponderant oxygenates in emissions but are emitted in minor amounts when compared to hydrocarbon, carbon dioxide, carbon monoxide and nitrogen oxide emissions. Many oxygenated compounds are formed as secondary products from photochemical reactions (Tuesday, 1971).

5.1.2.3 The Oxides of Carbon

Carbon Dioxide

Carbon dioxide is not generally considered an air pollutant. It is non-toxic, and immense quantities of it (10^{12} tons) are cycled through the biosphere annually (Robinson and Robbins, 1972). It is an essential ingredient of plant and animal life cycles. Through photosynthesis, it is converted to plant tissues; oxygen is produced as a by-product. Without photosynthesis, the world's supply of oxygen would reduce drastically to that formed by lightning and photolytic processes acting on water (Mason, 1966; Riehl, 1972).

The concentration of carbon dioxide in air is variable and depends upon whatever sources or sinks are present and such factors as the growing season when plants tend to deplete the amounts present. Callendar (1958) studied carbon dioxide measurements from 1870 to 1955 (Figure 5.1-5). A nineteenth century base value of 290 ppm was established and is generally accepted. Present day values have been set at 320 ppm with an annual growth rate of about 0.7 ppm (Robinson and Robbins, 1972).

Worldwide combustion of fossil fuel is a primary cause of the relatively rapid increase in carbon dioxide in the atmosphere. Robinson and Robbins (1972) have reviewed the sources, sinks and effects of carbon dioxide. Table 5.1-8 shows carbon dioxide emissions projected to the year 2000. A relative increase of nearly 300% in emissions over those of 1965 is predicted. Robinson and Robbins (1972) assume that half the carbon dioxide emitted remains in the atmosphere. This would result in an increase to about 370 ppm.

Carbon dioxide contributes to what is called a "greenhouse" effect in the atmosphere. As in a greenhouse, radiation penetrates the atmosphere and is absorbed by the earth. The earth also radiates energy into space at a reduced level and at longer wavelengths; otherwise, the earth's temperature would continue to increase in temperature indefinitely. A balance is maintained between the incoming and outgoing energy. Figure 5.1-6 (Sellers, 1965) shows two radiation envelopes: one at 6000°K to indicate the radiation coming in from the sun; the other at 300°K to indicate the energy radiating from the earth at longer wavelengths. Carbon dioxide absorbs radiation strongly from this envelope and consequently contributes to a warming, or

Table 5.1-7
Oxygenates in Exhaust from Simple Hydrocarbon Fuels

Oxygenate	Concentration range, ppm ^a
Acetaldehyde	0.8-4.9
Propionaldehyde (+ acetone) ^b	2.3-14.0
Acrolein	0.2-5.3
Crotonaldehyde (+ toluene) ^c	0.1-7.0
Tiglaldehyde	<0.1-0.7
Benzaldehyde	<0.1-13.5
Tolualdehyde	<0.1-2.6
Ethylbenzaldehyde	<0.1-0.2
<i>o</i> -Hydroxybenzaldehyde (+ C ₁₀ aromatic) ^d	<0.1-3.5
Acetone (+ propionaldehyde) ^b	2.3-14.0
Methyl ethyl ketone	<0.1-1.0
Methyl vinyl ketone (+ benzene) ^e	0.1-42.6
Methyl propyl (or isopropyl) ketone	<0.1-0.8
3-Methyl-3-buten-2-one	<0.1-0.8
4-Methyl-3-penten-2-one	<0.1-1.5
Acetophenone	<0.1-0.4
Methanol	0.1-0.6
Ethanol	<0.1-0.6
C ₆ alcohol (+ C ₈ aromatic) ^f	<0.1-1.1
2-Buten-1-ol (+ C ₆ H ₆ O)	<0.1-3.6
Benzyl alcohol	<0.1-0.6
Phenol + cresol(s)	<0.1-6.7
2,2,4,4-Tetramethyltetrahydrofuran	<0.1-6.4
Benzofuran	<0.1-2.8
Methyl phenyl ether	<0.1
Methyl formate	<0.1-0.7
Nitromethane	<0.8-5.0
C ₄ H ₈ O	<0.1
C ₆ H ₈ O	<0.1-0.2
C ₈ H ₁₀ O	<0.1-0.3

- ^a Values represent concentration levels in exhaust from all test fuels.
- ^b Data represent unresolved mixture of propionaldehyde + acetone. Chromatographic peak shape suggests acetone to be the predominant component.
- ^c Toluene is the predominant component.
- ^d The C₁₀ aromatic hydrocarbon is the predominant component.
- ^e Benzene is the predominant component.
- ^f The aromatic hydrocarbon is the predominant component.

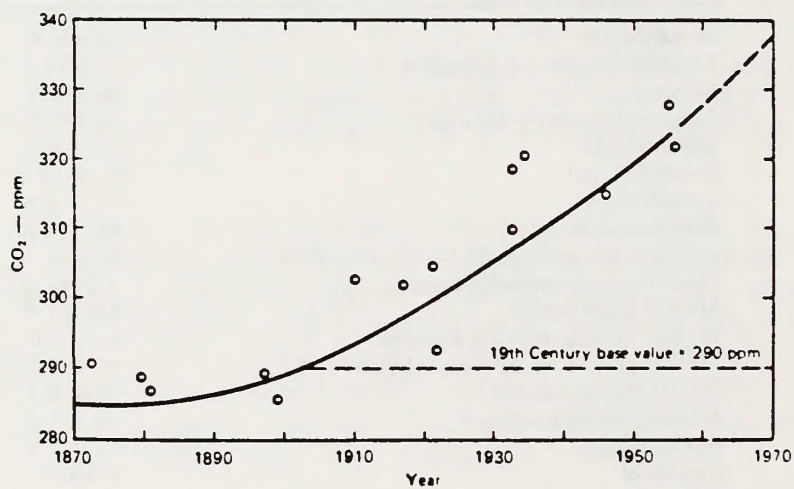

Figure 5.1-5
Average CO₂ concentration in North Atlantic region 1870-1956.

Table 5.1-8
 Projected CO₂ Emissions: 1965-2000

	<i>Emissions, 10⁶ tons/year</i>				
	<i>1965</i>	<i>1970</i>	<i>1980</i>	<i>1990</i>	<i>2000</i>
Coal	7.33	7.40	7.55	7.70	7.85
Petroleum	4.03	5.28	8.57	13.90	22.50
Natural gas	1.19	1.62	2.79	4.80	8.27
Incineration	0.46	0.51	0.61	0.73	0.88
Wood fuel	0.68	0.68	0.68	0.68	0.68
Forest fires	0.39	0.39	0.39	0.39	0.39
Total	14.08	15.88	20.59	28.20	40.57
Relative change	100%	113%	146%	200%	288%

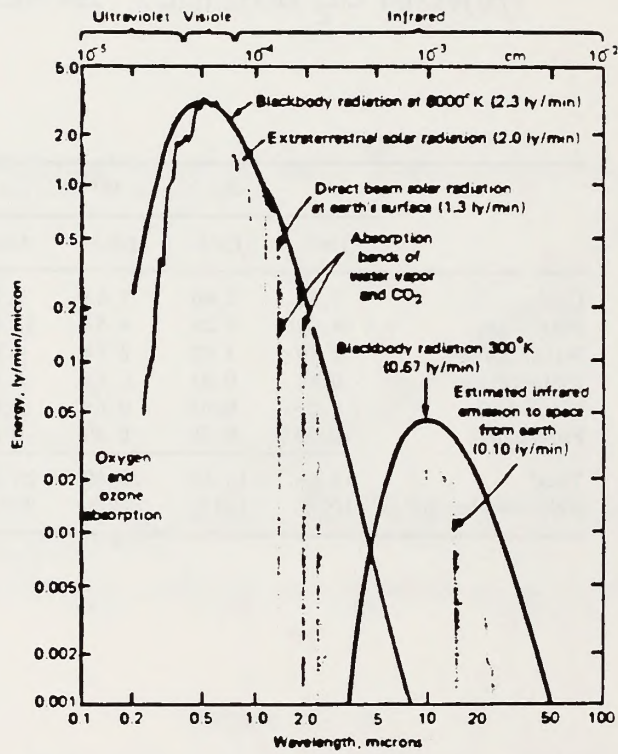

Figure 5.1-6
Spectra of Solar and Earth Radiation

greenhouse, effect. The temperature increase theoretically resulting from an increase of concentration to 370 ppm would be 0.5°C (Manabe and Wetherald, 1967). In reality the earth's energy balance is much more complicated. Water vapor, which absorbs strongly in the infrared, the amount of clouds which reflect sunlight, and global atmospheric circulation patterns all play important roles (Robinson and Robbins, 1972; Sellers, 1965). An increase in the reflectivity of the earth's atmosphere caused by an increase in suspended particulate matter (McCormick and Ludwig, 1967) or an increase in cloud cover could offset the warming tendency of carbon dioxide.

Carbon Monoxide

Carbon monoxide is a colorless, odorless, and tasteless gas which is slightly lighter than air. It is considered a dangerous asphyxiant because it combines strongly with the hemoglobin of the blood and reduces the blood's ability to carry oxygen to cell tissues. Untold numbers of deaths have been caused by carbon monoxide in coal mines, fires and non-ventilated places. A healthy working person can work eight hours a day, 40 hours a week, without noticeable adverse effects at carbon monoxide concentrations of 25 ppm (the threshold limit value).

Carbon monoxide is a product of incomplete combustion of carbon and its compounds. It is emitted by fossil fuel combustion sources in greater quantities than all other pollutant sources combined. Table 5.1-9 summarizes the estimates of emissions in the United States (Cavender et al, 1973). The automobile is by far the largest single pollution emission source. Figure 5.1-7 shows that maximum carbon monoxide concentrations found at eight Continuous Air Monitoring Program (CAMP) stations in the United States (Chang and Weinstock, 1973).

Recent carbon isotope studies conducted at the Argonne National Laboratory (Stevens et al, 1972) showed that nature produces huge quantities of carbon monoxide: from 3 to 640×10^9 tons/year as compared to 0.275×10^9 tons/year from worldwide pollution sources (Table 5.1-2). The principal natural source is believed to be the result of the photochemical oxidation of methane through an OH radical mechanism (Stevens et al, 1972; Weinstock, 1972). Other natural sources include the decomposition of chlorophyll to give relatively high concentrations of carbon monoxide particularly in the fall (0.2 to 0.5×10^9 tons/year). Volcanoes, natural gas, forest fires, bacterial action in the oceans (0.15×10^9 tons/year) are other sources. The estimated total amount of carbon monoxide emissions from natural sources, given in Table 5.1-2, are, consequently, low by 30- to 50-fold, and the residence time of carbon monoxide in air needs to be reduced by a factor of 0.1 to 0.3 per year (Weinstock, 1972; Maugh, 1972).

The background concentration of carbon monoxide is estimated from data gathered in the Pacific (Robinson and Robbins, 1972; 1970) to be approximately 0.1 ppm. Table 5.1-10

Table 5.1-9
 Estimates of Carbon Monoxide Emissions
 (United States) 1940-1970 (10⁶ tons/year)

<i>Source category</i>	<i>1940</i>	<i>1950</i>	<i>1960</i>	<i>1968</i>	<i>1969</i>	<i>1970</i>
Fuel combustion in stationary sources	6.2	5.6	2.6	2.0	1.8	0.8
Transportation	34.9	55.4	83.5	113.0	112.0	111.0
Solid waste disposal	1.8	2.6	5.1	8.0	7.9	7.2
Industrial process losses	14.4	18.9	17.7	8.5	12.0	11.4
Agricultural burning	9.1	10.4	12.4	13.9	13.8	13.8
Miscellaneous	19.0	10.0	6.4	5.0	6.3	3.0
Total	85.4	103.0	128.0	150.0	154.0	147.0
Total controllable*	66.4	92.9	121.0	145.0	148.0	144.0

* Miscellaneous sources not included.

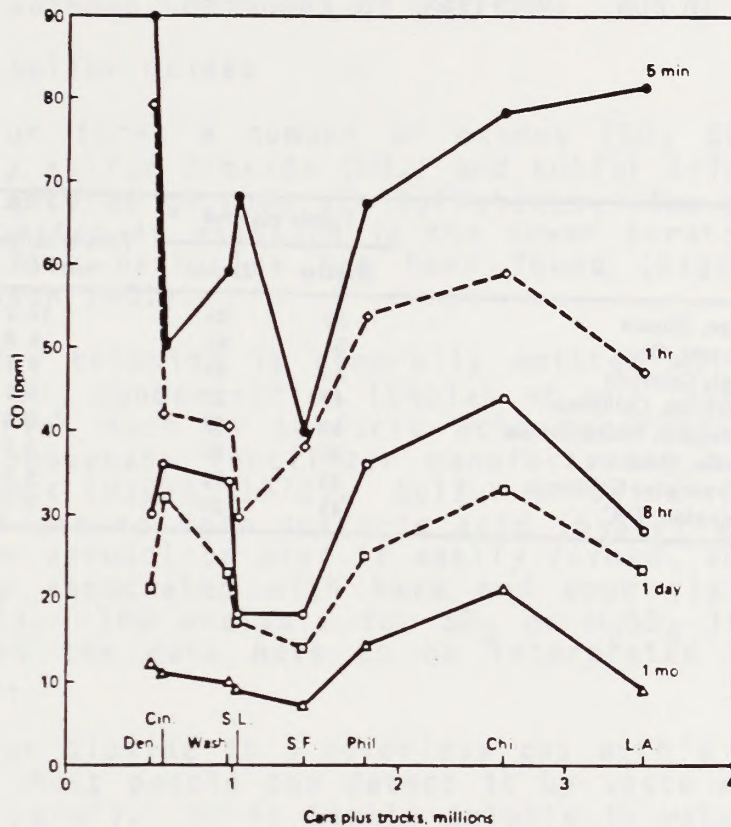

Figure 5.1-7

Maximum CO concentrations at Continuous Air Monitoring Program (CAMP) stations. 1962-1963 maxima vs cars plus trucks. Denver (Den.), Colorado; Cincinnati (Cin.), Ohio; Washington (Wash.), D.C.; St. Louis (S.L.), Missouri; San Francisco (S.F.), California; Philadelphia (Phil.), Pennsylvania; Chicago (Chi.), Illinois; Los Angeles (L.A.), California.

Table 5.1-10

Carbon Monoxide Concentrations in Representative United States Cities.
Hourly Maxima in ppm. 1962-1967

	<i>Yearly maxima</i>		<i>Theoretical geometric mean (17, 51)</i>
	<i>Highest</i>	<i>Lowest</i>	
Chicago, Illinois	59	28	13.2
Cincinnati, Ohio	34	20	4.8
Denver, Colorado	55	40	6.7
Los Angeles, California	47	35	9.7
Philadelphia, Pennsylvania	54	37	6.9
St. Louis, Missouri	29	25	5.5
San Francisco, California	38	22	4.8
Washington, D.C.	41	25	3.5

shows the range of maximum hourly average values for the years of 1962-1967 for eight major United States cities (USEPA, 1970; Faith and Atkisson, 1972). The theoretical geometric mean hourly concentrations for the entire period are also shown. CO concentrations are more than ten times the level of concentrations of other major pollutants.

5.1.3 The Gaseous Compounds of Sulfur

5.1.3.1 The Sulfur Oxides

Sulfur forms a number of oxides (SO , SO_2 , S_2O_3 , SO_3 , S_2O_7) but only sulfur dioxide (SO_2) and sulfur trioxide (SO_3) are of any importance as gaseous air pollutants. The peroxide, S_2O_7 , has been suggested as existing in the lower stratosphere where a layer of sulfate particles has been found (Bigg et al, 1970; Junge and Manson 1961).

Sulfur trioxide is generally emitted with SO_2 at about 1%-5% of the SO_2 concentration (Cholak et al, 1958; Tice, 1962). A few industries such as sulfuric acid manufacturing, electroplating and phosphate fertilizer manufacturing may emit higher relative amounts (USEPA, 1972). Sulfur trioxide rapidly combines with water in air to form sulfuric acid (H_2SO_4) which has a low dew point. An aerosol or mist is easily formed, and SO_3 or H_2SO_4 is frequently associated with haze and poor visibility in air (Figure 5.1-8). The analysis for SO_3 or H_2SO_4 in air is quite difficult, and the data have to be interpreted with some care (USEPA, 1972).

Sulfur dioxide is a colorless gas with a pungent, irritating odor. Most people can detect it by taste at 0.3 to 1 ppm (780 to 2620 $\mu\text{g}/\text{m}^3$). It is highly soluble in water: 11.3 gm/100 ml as compared to 0.169 gm/100 ml for carbon dioxide, forming weakly acidic sulfurous acid (H_2SO_3). In clean air, it oxidizes slowly to sulfur trioxide. It is oxidized more readily by atmospheric oxygen in aqueous aerosols. Heavy metal ions in solution catalyze the reaction which stops when aerosols become acidic. Atmospheric ammonia neutralizes the acid to form ammonium sulfate, which is commonly found in atmospheric particles (Johnstone and Coughanowr, 1958, 1960). In moist air and in the presence of nitrogen oxides, hydrocarbons, and particulates, sulfur dioxide reacts much more rapidly (Urone, 1972; Urone and Schroeder, 1969).

Today, sulfur dioxide remains one of the major atmospheric pollutants. Its worldwide emissions have been estimated at 146 megatons/year by Robinson and Robbins (Table 5.1-2) and more recently as 100 (150 as sulfate) megatons per year by Kellogg et al. (1972) who predict emissions of about 275 megatons per year for the year of 2000. Estimated United States sulfur dioxide emissions for 1970 were 33.9 megatons (Table 5.1-11). Fuel combustion and stationary sources and industrial emissions accounted for 70% and 18% of this figure, respectively (Cavender,

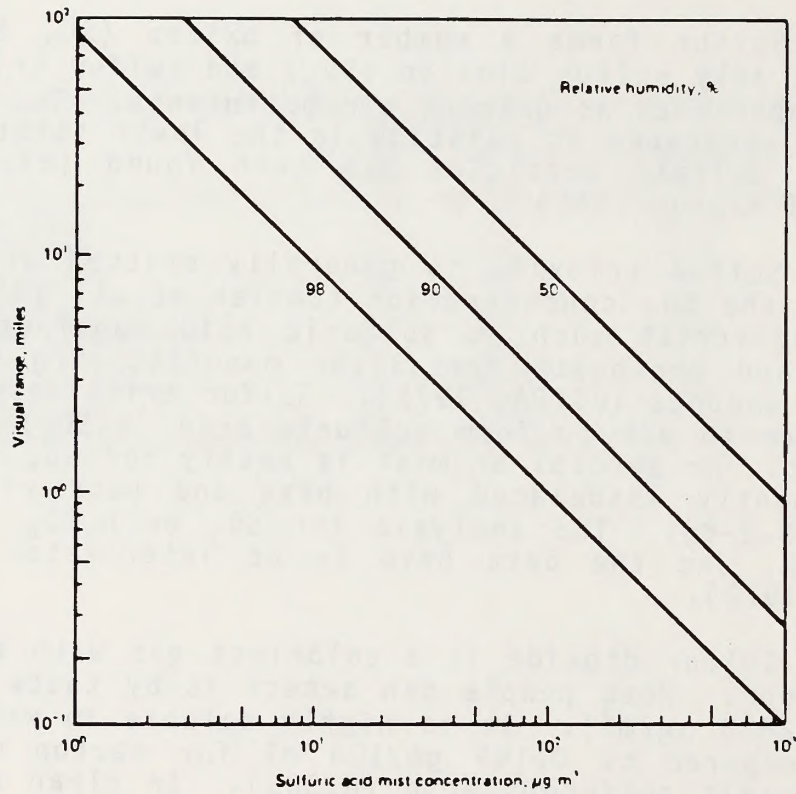

Figure 5.1-3

Calculated visibility (visual range) in miles at various sulfuric acid mist concentrations and different relative humidities.

Table 5.1-11

Estimates of Sulfur Oxide Emissions (United States)
1940-1970 (10^6 tons/year)

<i>Source category</i>	<i>1940</i>	<i>1950</i>	<i>1960</i>	<i>1968</i>	<i>1969</i>	<i>1970</i>
Fuel combustion in stationary sources	16.8	18.3	17.5	24.7	25.0	26.5
Transportation	0.7	1.0	0.7	1.1	1.1	1.0
Solid waste disposal	Neg ^a	0.1	0.1	0.1	0.2	0.1
Industrial process losses	3.8	4.2	4.7	5.1	5.9	6.0
Agricultural burning	Neg	Neg	Neg	Neg	Neg	Neg
Miscellaneous	0.2	0.2	0.3	0.3	0.2	0.3
Total	21.5	23.8	23.3	31.3	32.4	33.9
Total controllable ^b	21.3	23.6	23.0	31.0	32.2	33.6

^a Negligible (less than 0.05×10^6 tons/year).

^b Miscellaneous sources not included.

Table 5.1-12

Sulfur Dioxide Concentrations in Representative
United States Cities Hourly Maxima, ppm, 1962-1967

	<i>Yearly maxima</i>		<i>Theoretical geometric mean (17, 51)</i>
	<i>Highest</i>	<i>Lowest</i>	
Chicago, Illinois	1.69	0.86	0.111
Cincinnati, Ohio	0.57	0.41	0.018
Denver, Colorado	0.36	0.17	0.014
Los Angeles, California	0.29	0.13	0.014
Philadelphia, Pennsylvania	1.03	0.66	0.060
St. Louis, Missouri	0.96	0.55	0.031
San Francisco, California	0.26	0.11	0.006
Washington, D.C.	0.62	0.35	0.042

et al, 1973). Intensive efforts are being made to control sulfur dioxide emissions by either removing sulfur from coal and oil or removing sulfur dioxide at the combustion source (USEPA, 1969).

Ambient air concentrations of sulfur dioxide are routinely measured in many cities and have been the subject of a large number of studies. Table 5.1-12 give typical data obtained from the United States Continuous Air Monitoring Program (CAMP). Figure 5.1-9 shows the frequency distribution of sulfur dioxide measurements made in selected United States cities. An approximate log-normal distribution is shown by the straight portions of the lines. This confirms to some extent the model developed by Larsen and others (Larsen, 1969; USEPA, 1969; Larsen, 1971).

5.1.3.2 Reduced Sulfur Compounds

Hydrogen Sulfide

Hydrogen sulfide (H_2S) is a toxic, foul smelling gas well known for its rotten egglike odor. It can be detected at concentrations as low as 0.5 ppb ($7 \mu g/m^3$) (A.D. Little, Inc., 1968). Its natural emission sources include anaerobic biological decay processes on land, in marshes and in the oceans. Volcanoes and natural hot water springs also emit hydrogen sulfide. A total of approximately 100 megatons (268 when expressed as sulfate) is estimated to be emitted in nature (Table 5.1-2) (Kellogg et al, 1972). However this estimate has been made with strong reservations. The analysis of very low concentrations in air is subject to error because some of the hydrogen sulfide is oxidized to sulfur dioxide during the sampling process (Kellogg et al, 1972).

Approximately three megatons of H_2S are estimated to be emitted each year by pollution sources (Robinson and Robbins, 1972) (Table 5.1-2). One of the larger single sources is the kraft pulp industry which uses a sulfide process to extract cellulose from wood (Blosser, 1972). Because of the strong odor of sulfides, such facilities can be detected by their odor 40 miles or more downwind, unless emissions are carefully controlled. Other hydrogen sulfide pollution sources include the rayon industry, coke ovens and the oil refining industry. The processing of "sour" crude oil results in the emission of hydrogen sulfide and other volatile organic sulfides. Hydrogen sulfide emissions from industrial processes are sometimes used as fuel for boilers or are released in burning flares. In either case, they are burned to sulfur dioxide and emitted to the air. Today, many modern refineries recover their sour gasses and process them to form sulfuric acid or elemental sulfur (Faith et al, 1965).

Hydrogen sulfide concentrations in urban air are rarely higher than 0.1 ppm ($140 \mu g/m^3$). Cholak (1952) analyzed Cincinnati air over a period of five years, and rarely found hydrogen sulfide to exceed 0.01 ppm ($14 \mu g/m^3$). A survey in Houston,

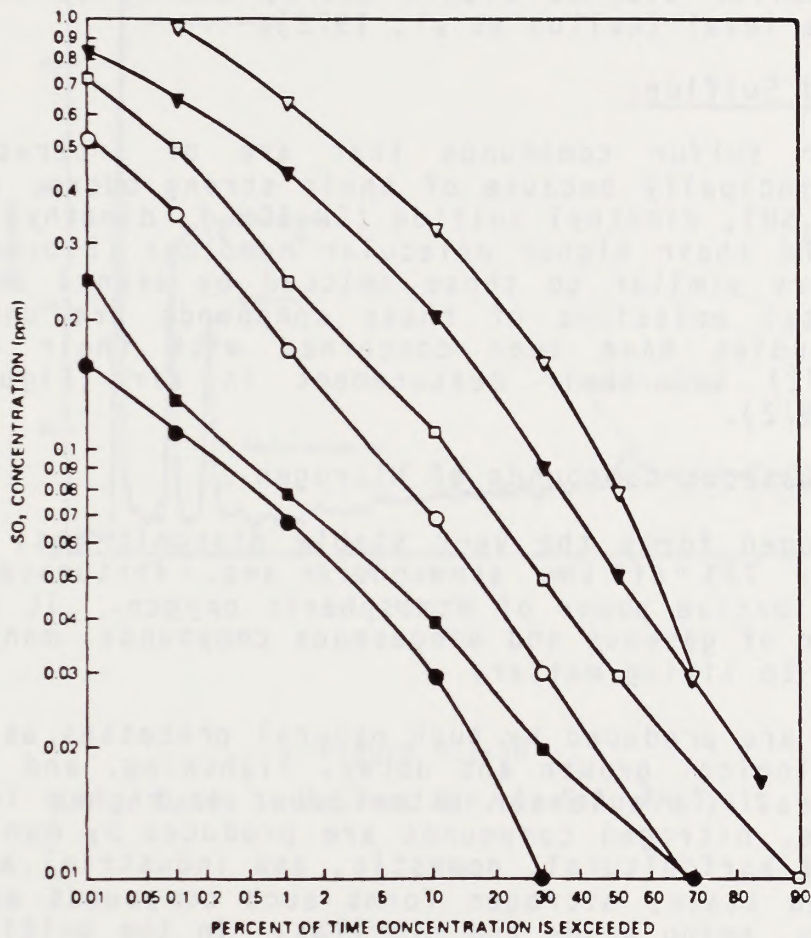

Figure 5.1-9

Frequency distribution of sulfur dioxide levels in selected United States cities, 1962-1967. ∇ , Chicago, Illinois; \blacktriangledown , Philadelphia, Pennsylvania; \square , St. Louis, Missouri; \blacksquare , Cincinnati, Ohio; \circ , Los Angeles, California; \bullet , San Francisco, California.

Texas showed average values of 0.02 ppm in the most highly polluted section of the city. The highest level measured was 0.28 ppm ($390 \mu\text{g}/\text{m}^3$) (Faith and Atkisson, 1972; SRI, 1957). Katz (1955) found relatively high levels in Windsor, Ontario with a mean concentration of approximately 0.1 ppm and a maximum of 0.6 ppm ($835 \mu\text{g}/\text{m}^3$).

Hydrogen sulfide blackens lead-based paints. A level of 0.1 ppm is said to produce blackening of such paints within 1 hour (Faith and Atkisson, 1972). In air, hydrogen sulfide is oxidized to sulfur dioxide within hours, adding to the ambient sulfur dioxide level (Kellog et al, 1972).

Mercaptans and Sulfides

Other sulfur compounds that are of interest in air pollution, principally because of their strong odors, are methyl mercaptan (CH_3SH), dimethyl sulfide (CH_3SCH_3), dimethyl disulfide (CH_3SSCH_3), and their higher molecular homologs (Blosser, 1972). They have odors similar to those emitted by skunks and rotting cabbage. Total emissions of these compounds are unknown. A number of studies have been concerned with their evaluation (Schmall, 1972) and their measurement in air (Figure 5.1-10 (Rasmussen, 1972)).

5.1.4 The Gaseous Compounds of Nitrogen

Nitrogen forms the very stable diatomic gas, N_2 , which makes up over 78% of the atmosphere and, fortunately, helps temper the oxidative power of atmospheric oxygen. It also forms a large number of gaseous and nongaseous compounds, many of which are essential to living matter.

They are produced by such natural processes as bacterial fixation, biological growth and decay, lightning, and forest and grassland fires. To a lesser extent, but in higher local urban concentrations, nitrogen compounds are produced by man through a wide number of agricultural, domestic, and industrial activities. In the reduced state, nitrogen forms such compounds as ammonia, amides, amines, amino acids and nitriles. In the oxidized state, it forms seven oxides and a large number of nitro, nitroso, nitrite and nitrate derivatives (Cotton and Wilkinson, 1966).

5.1.4.1 The Oxides of Nitrogen

The oxides of nitrogen include nitrous oxide (N_2O), nitric oxide (NO), nitrogen dioxide (NO_2), nitrogen trioxide (NO_3), nitrogen sesquioxide (N_2O_3), nitrogen tetroxide (N_2O_4), and nitrogen pentoxide (N_2O_5). They and two of their hydrates, nitrous acid (HNO_2) and nitric oxide (NO), and nitrogen dioxide (NO_2) are found in appreciable quantities. The latter two, NO and NO_2 , are often analyzed together in air and are referred to as "nitrogen oxides" and given the symbol " NO_x ". Nitrous oxide

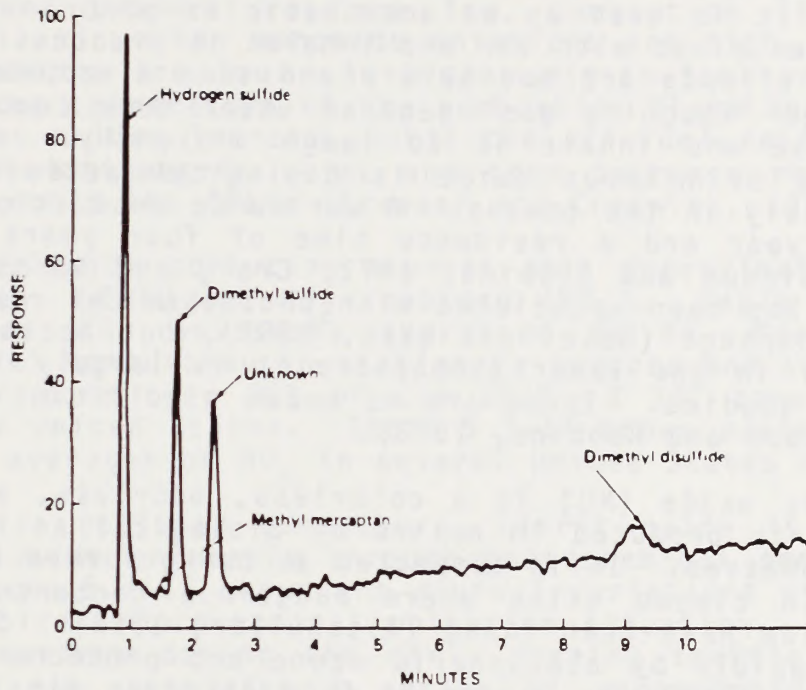

Figure 5.1-10
Sulfur Gases in Ambient Air, In-Situ Analysis

(N₂O) is not included in the "NO" measurement, but it is possible for the higher oxides to be^x included if they happen to be present (APHA, 1972).

Nitrous oxide (N₂O) is a colorless, slightly sweet, nontoxic gas present in the natural environment in relatively large amounts (0.25 ppm) when compared to the concentrations of the other trace gases except carbon dioxide, methane, and the noble gases. It is used as an anesthetic in minor surgery and dentistry. When mixed with air and inhaled it produces a loss of feeling. Its effects are not severe and soon disappear. It is commonly called "laughing gas" because under some conditions it can cause those who inhale it to laugh violently. The major natural source of nitrous oxide is biological activity in the soil and possibly in the oceans. A worldwide production rate of 10⁹ tons per year and a residence time of four years has been estimated (Robinson and Robbins, 1972; Craig and Gordon, 1963). Nitrous oxide has been associated with photochemical reactions in the upper atmosphere (Bates and Hays, 1967), but because of its low reactivity in the lower atmosphere it is largely ignored in air pollution studies. There are no known significant pollution sources (Robinson and Robbins, 1972).

Nitric oxide (NO) is a colorless, odorless, and tasteless gas. It is produced in nature by biological action and by combustion processes. It is suspected as being formed and rapidly oxidized in closed silos where dangerous concentrations of nitrogen dioxide have been found (Altshuller, 1958). In air, it is oxidized rapidly by atmospheric ozone and photochemical processes and more slowly by oxygen to form nitrogen dioxide (NO₂). Worldwide natural emissions are estimated by Robinson and Robbins (1972) to be 430 X 10⁶ tons per year. Background concentrations are variable and difficult to measure. They are estimated to range from 0.25 to 6 ppb. The residence time in air is about five days (Robinson and Robbins, 1972).

As a pollutant, nitric oxide is produced largely by fuel combustion in both stationary and mobile sources such as the automobile. In the high temperatures of the combustion zone, nitrogen reacts with oxygen to form nitric oxide:

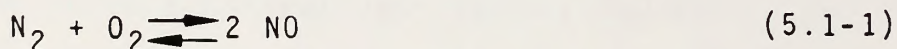

The reaction is endothermic and proceeds to the right at high temperatures. At low temperatures, the equilibrium lies almost completely to the left, but the rate of recombination is extremely slow. Consequently, the amount of NO emitted is a function of the flame structure and temperature as well as the rate at which the combustion mixture cools. If the cooling rate is rapid, equilibrium is not maintained and the NO concentration, although thermodynamically unstable, remains high (Trayser and Creswick, 1970; Hall and Blacet, 1952). The proper catalyst can, of course, expedite its decomposition to nitrogen and oxygen. In exhaust gases, where higher concentrations and temperatures

prevail, some of the nitric oxide is oxidized to nitrogen dioxide. This generally varies from 0.5% to 10% of the nitric oxide present (USEPA, 1971).

Figure 5.1-11 shows the relative amounts of nitrogen oxides, hydrocarbons, and carbon monoxide in the exhaust of an automobile as a function of the ratio of the air-to-fuel mixture used for the engine. At low air-to-fuel ratios ("rich" mixtures), flame temperatures are low, combustion is incomplete, hydrocarbon and carbon monoxide emissions are high, and nitrogen oxides emissions are low. At higher air-to-fuel ratios ("lean" mixtures) the temperature of the combustion flame becomes hotter, the nitrogen oxides increase until the air-fuel ratio is greater than the stoichiometric point and then decrease rapidly as the excess air cools the flame (Trayser and Creswick, 1970).

Worldwide pollution sources emit approximately 53×10^6 tons per year of NO and NO_2 combined (NO_x). Table 5.1-13 gives estimates of NO_x emissions expressed as NO_2 for the United States. Fuel combustion in stationary sources and transportation account for more than 95% of the 22.7×10^6 tons emitted per year in the United States. Table 5.1-14 shows maximum and minimum hourly averages of NO_x in several United States cities.

In a polluted atmosphere, nitric oxide is oxidized to nitrogen dioxide primarily through photochemical secondary reactions. Figure 5.1-12 shows the diurnal variations of NO , NO_2 , and O_3 in a typical photochemical pollution situation. Nitric oxide reaches a maximum during the early morning traffic rush hours. The rising sun initiates a series of photochemical reactions which convert the nitric oxide to nitrogen dioxide. Within a few hours the nitrogen dioxide reaches a maximum during which it photochemically reacts to form ozone and other oxidants. Both the nitrogen dioxide and the ozone eventually disappear through the formation of nitrated organic compounds, peroxides, aerosols, and other terminal products. The cycle is repeated the following day. If the air mass is not swept away or is brought back by a reversing wind, the residual gases add to the new day's pollutants (Tuesday, 1971).

Nitrogen dioxide is a reddish-brown gas with a pungent, irritating odor. At concentrations higher than those found in the atmosphere, it forms a colorless dimer, nitrogen tetroxide (N_2O_4). Natural emissions are due primarily to biological decay involving nitrates being reduced to nitrites, followed by conversion to nitrous acid (HNO_2), decomposition to nitric oxide and oxidation to nitrogen dioxide. Natural emissions are estimated to be 658×10^6 tons per year.

Nitrogen dioxide is one of the more invidious pollutants. It is irritating and corrosive in itself, but more importantly, it serves as an energy trap by absorbing sunlight to form nitric oxide and atomic oxygen:

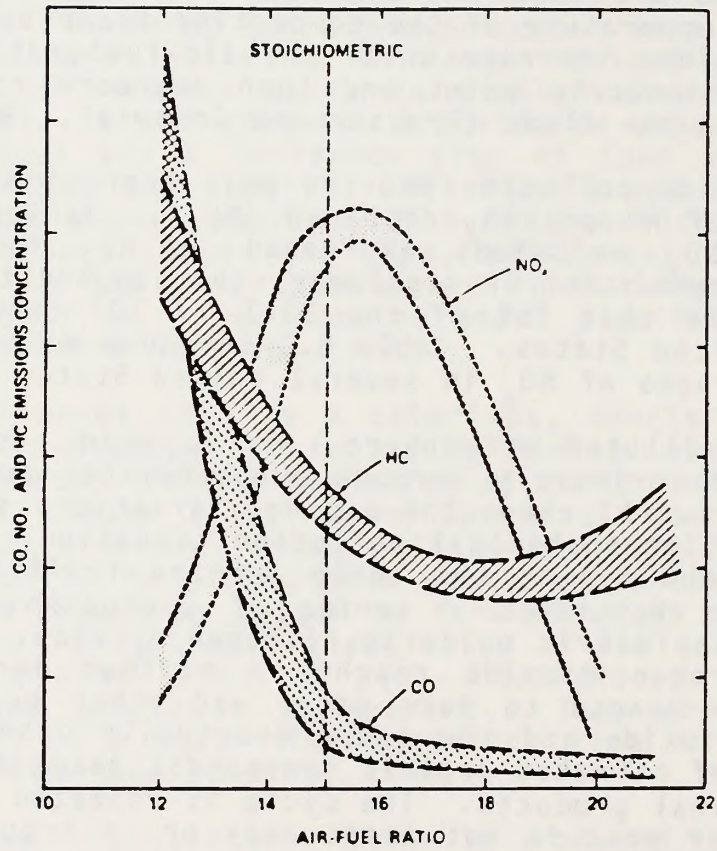

Figure 5.1-11
Effects of air-fuel ratio on exhaust composition
(approximate ranges, not to scale).

Table 5.1-13
 Estimates of Nitrogen Oxide (NO_x) Emissions
 (United States), 1940-1970 (10⁶ tons/year)

Source category	1940	1950	1960	1968	1969	1970
Fuel combustion in stationary sources	3.5	4.3	5.2	9.7	10.2	10.0
Transportation	3.2	5.2	8.0	10.6	11.2	11.7
Solid waste disposal	0.1	0.2	0.2	0.4	0.4	0.4
Industrial process losses	Neg ^a	0.1	0.1	0.2	0.2	0.2
Agricultural burning	0.2	0.2	0.3	0.3	0.3	0.3
Miscellaneous	0.8	0.4	0.2	0.2	0.2	0.1
Total	7.9	10.4	14.0	21.3	22.5	22.7
Total controllable ^b	7.1	10.0	13.8	21.1	22.3	22.6

^a Negligible (less than 0.05×10^6 tons/year).

^b Miscellaneous sources not included.

Table 5.1-14
 Nitrogen Oxide (NO_x) Concentrations in Representative
 United States Cities Hourly Maxima, ppm, 1962-1968

	Yearly maxima		Geometric mean
	Highest	Lowest	
Chicago, Illinois	1.06	0.69	0.75
Cincinnati, Ohio	1.42	0.45	0.83
Denver, Colorado ^a	0.72	0.56	0.62
Los Angeles, California	1.35	0.98	1.24
Philadelphia, Pennsylvania	1.79	0.97	1.53
St. Louis, Missouri ^b	0.92	0.44	0.57
Washington, D.C.	1.30	0.68	0.83

^a 1965-1968

^b 1964-1968

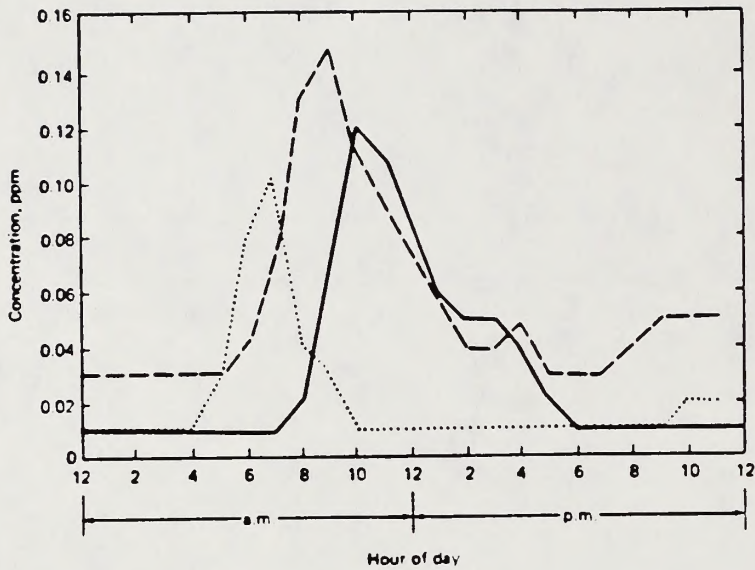

Figure 5.1-12

Typical diurnal variation of NO, NO₂, and O₃ concentrations in Los Angeles, California. Solid line, ozone; long dashed line, nitrogen dioxide; dotted line, nitric oxide.

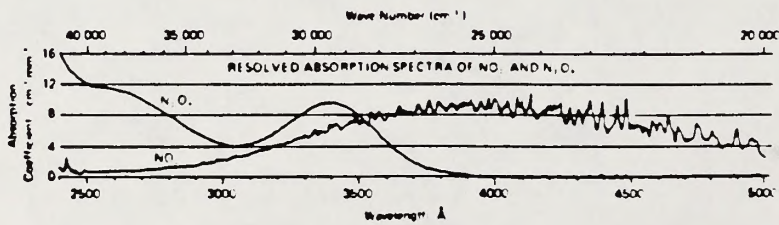
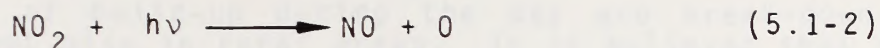

Figure 5.1-13

Absorption coefficients ($1/p \log_{10} |o/|$) of NO₂ and N₂O₄ vs wavelength and wave number, measured at 25°C.



The atomic oxygen is very reactive, forming ozone with oxygen, and initiating a number of secondary photochemical chain reactions. Nitrogen dioxide absorbs light strongly in the yellow to blue end of the visible spectrum and the near ultraviolet. Figure 5.1-13 (Hall and Blacet, 1952) shows the absorption spectrum of nitrogen dioxide, and Figure 5.1-14 (USEPA, 1971) indicates the amount of light absorbed in terms of parts per million - mile concentrations. A mile thick layer of air containing 0.1 ppm of NO_2 reduces the ultraviolet light reaching the ground by more than 25%. Viewed through a horizontal layer of 10 miles, the same concentration reduces the blue and ultraviolet light more than 90% (Figure 5.1-14). The yellow-brown haze often seen hovering over a city is in a large part due to nitrogen dioxide and the aerosols it helps generate (Carlson and Ahlquist, 1969).

Nitrogen trioxide (NO_3) and nitrogen pentoxide (N_2O_5) have been postulated as intermediates in the photochemical oxidation of hydrocarbons and sulfur dioxide (Urone, 1972; Louw, 1973; Gay and Bufalini, 1971; Schuck et al, 1966). They are not commonly observed; their concentrations are expected to be small and difficult to measure in air in the presence of NO , NO_2 and their various photochemical reaction products. The pentoxide hydrolyzes readily with water vapor in the air to form nitric acid vapor (HNO_3) which has been detected in the stratosphere by spectroscopic means (Cadle and Allen, 1970). Peroxyacetyl nitrate (PAN), an eye-irritating photochemical reaction product from hydrocarbons and nitrogen oxides, has been identified and measured in air (Hall and Blacet, 1952; Hanst, 1971). Atmospheric concentrations as high as 0.1 ppm ($500 \mu\text{g}/\text{m}^3$) have been reported (USEPA, 1971).

5.1.5 Ozone and Oxidants

Ozone, O_3 , is a bluish gas about 1.6 times as heavy as air and highly reactive. It is formed at high altitudes by photochemical reactions involving molecular and atomic oxygen (Cotton and Wilkinson, 1966). Its concentration in the atmosphere depends upon the altitude; being greatest in the stratosphere. At 20 km, its concentration is 0.20 ppm. Its concentration in rural areas, away from pollution sources, is approximately 0.02 ppm (USEPA, 1970). Very minor amounts of ozone are formed during lightning and thunderstorms. Ozone strongly absorbs ultraviolet light in the wavelength region of 2000-3500 Å and very weakly at about 6000 Å. Its absorption of the energetic portion of the ultraviolet light prevents serious damage to living tissues (USEPA, 1970).

Ozone and other oxidants such as PAN (Stephens, 1961) and hydrogen peroxide (Bufalini et al, 1972) are formed in polluted atmospheres as a result of a rather wide variety of photochemical reactions (Tuesday, 1971; Leighton, 1961). High ozone levels have been found not only in urban areas, where it follows

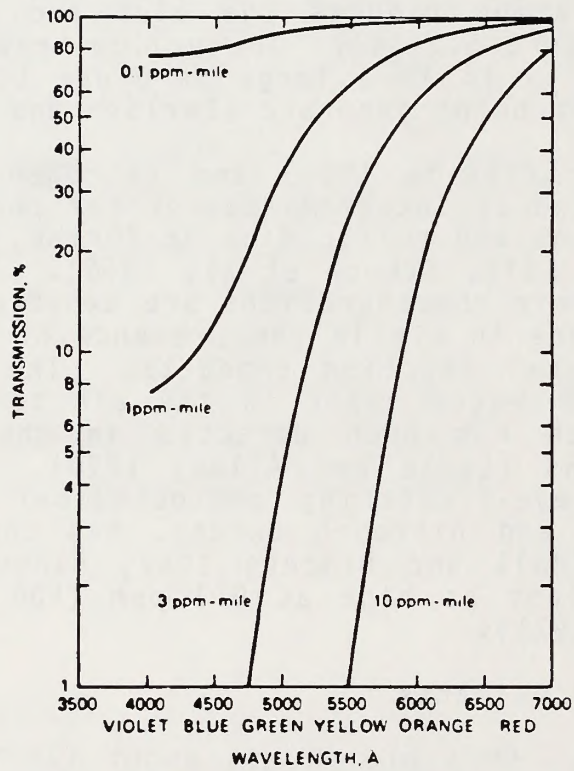

Figure 5.1-14
 Transmittance of Visible Light at Different NO_2
 Concentrations and Viewing Distances

a trend of build-up during the day and break-down during the night, but also in rural areas. It is believed that ozone or its precursors are being transported long distances or there may be a natural source within rural areas.

The overall effect of ozone is a stinging of the eyes and mucous membranes. This reaction was first noticed in Pasadena, California, a suburb of Los Angeles. Shortly thereafter, polluted atmospheres were labeled as "Los Angeles" type because of their general oxidative character. "London" (England) type smogs (i.e., smoke plus fog) were reductive in nature because of their higher concentrations of sulfur dioxide and soot from the burning of coal. Figure 5.1-12 shows the diurnal variation of nitrogen oxides and ozone in a typical Los Angeles type of photochemical pollution. However, since London has cleared its air with a vigorous smoke abatement program, it is experiencing Los Angeles type of pollution as shown by Figure 5.1-15 (Derwent and Stewart, 1973).

To prevent possible serious health effects, an ambient air quality standard maximum 1-hour concentration of 240 g/m^3 (0.12 ppm) has been adopted. Alert levels were set at 200 g/m^3 (0.1 ppm). Figure 5.1-16 shows the number of times that the alert level was exceeded in Los Angeles, California for 1967 thru 1971 (Sagersky, 1973). A study of oxidant levels in the San Francisco, California Bay Area show a trend to smaller annual oxidant levels (Cramer, 1973). However greater efforts are needed to reduce these values. Two studies have shown that indoor air follows outdoor air concentrations rather closely (Mueller, et al, 1973; Thompson et al, 1973).

A number of areas have been measuring total oxidant and ozone concentrations above the alert levels (USEPA). There is reason to believe that the "oxidative" conditions in these instances are not the same as those found in larger cities. Riperton, et al. (1971), for example, have found evidence for tropospheric photochemical production of ozone.

Chesick (1972) and others (IDA, 1973) have been concerned over the effect that high-flying jet planes would have on the upper atmosphere. Water vapor and nitrogen oxides emitted from the jet exhausts conceivably could react with ozone and reduce its insulating quality for strong ultra-violet rays.

5.1.6 Particulate Matter

The particulate matter commonly found dispersed in the atmosphere is composed of many substances: flourides, beryllium, lead, and asbestos (all toxic), aerosols, dust and other matter such as wood waste generated by forest fires. Combustion also produces particles. Particles larger than 10 μm result from many mechanical processes such as wind erosion, grinding and spraying. Trees produce terpenes which can result in organic particles and oceans produce salt particles as well. Only three general classes of physical properties can reasonably be said to apply to all particulate matter. These properties all involve the interface

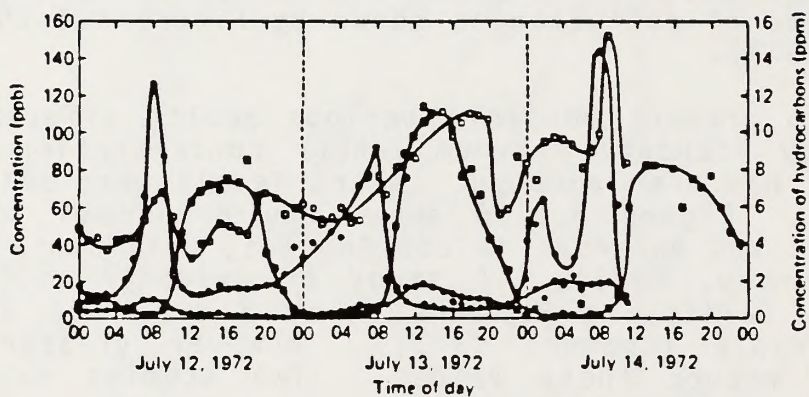

Figure 5.1-15

Diurnal variations of air pollutants measured in London, England from July 12 to July 14, 1972. ■, Ozone, ppb; ●, nitric oxide, ppb; □, nitrogen dioxide, ppb; ○, hydrocarbons, ppm.

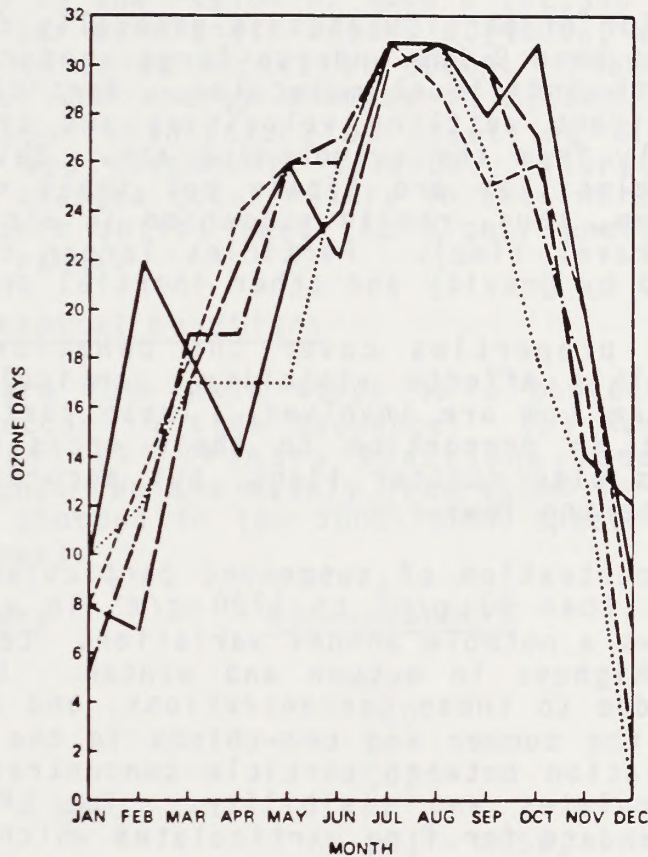

Figure 5.1-16

The number of days each month in Los Angeles County, California during which the ozone concentration has risen to 0.1 ppm or above. Solid line: 1967; short dashed line: 1968; long dashed line: 1969, dashed-dotted line: 1970; dotted line: 1971.

between particles and their surroundings, and include (1) surface properties, (2) motion, and (3) optical properties.

Surface properties include sorption, nucleation and adhesion, among others. Sorption is the deposition of molecules due to collision with an object. If the molecules are in a supersaturated atmosphere, the deposited molecules can attract other molecules causing them to condense out around the original deposit. This is nucleation.

The motion of particulates is generally defined by size. Particles of less than $0.1\mu\text{m}$ undergo large random motions caused by collisions with individual molecules. Particles larger than $1\mu\text{m}$ have significant settling velocities and their motion can vary significantly from the surrounding air. Between $0.1\mu\text{m}$ and $1\mu\text{m}$, settling velocities are finite but small compared to air motion. These can, thus, remain suspended in air for long periods (and long travel time). Particles larger than $5\text{-}10\mu\text{m}$ are generally removed by gravity and other inertial processes.

Optical properties cover the behavior of particles toward light. This affects visibility, particularly when particles larger than $1\mu\text{m}$ are involved. These particles intercept or scatter light in proportion to their cross-sectional area. Smaller particles also scatter light, but according to far more complicated scattering laws.

The concentration of suspended particulate matter which ranges from less than $60\mu\text{g}/\text{m}^3$ to $1700\mu\text{g}/\text{m}^3$ in various American cities often shows a notable annual variation. Levels are lowest in summer and highest in autumn and winter. Losses of solar radiation occur due to these concentrations, and can run as high as one-third in the summer and two-thirds in the winter. There is also a correlation between particle concentrations and rainfall, and particulates and visibility. The EPA is presently considering a standard for fine particulates which are felt to be the most important in terms of (1) the respirable fraction, (2) the catalytic conversion to secondary contaminants and (3) visibility impairment.

Although raw auto exhaust contains some particulate matter (smoke particles), this is not sufficient to degrade visibility significantly when diluted several thousandfold with air. However, aerosols can be formed by irradiation of dilute auto exhaust or of hydrocarbon/ NO_x mixtures. Aerosol formation is much enhanced by the addition of sulfur dioxide to the mixture. This suggests that sulfuric acid plays a role since H_2SO_4 is not only very nonvolatile but it also will absorb water.

5.1.7 Atmospheric Chemistry of Air Pollution

The solution of many air pollution problems involves knowledge of the chemistry of the atmosphere, when it may be termed "clean" and when it is "dirty." Also, the nature of air

pollutants as they react as a whole must be determined. In general, the two classes of polluted smogs are called either the London type - a reducing smog where contaminants form nuclei for condensation of water vapor into fogs--or the Los Angeles type - an oxidizing smog where contaminants are photolysed to irritants.

- Solar Radiation

The sun approaches a perfect black body radiator most closely in the region of 6000°K (12,300°F). Its maximum energy per wavelength occurs at 4500Å, while its maximum photon emission occurs at 6000Å. Photons produce many chemical and energy changes in matter at the molecular level upon absorption, by upsetting vibrational, rotational and electronic balance. Vibrational and rotational changes occur mainly in the infrared region while electronic shifts need the higher energy of the ultra-violet range.

- Photochemical Reactions

There are four main steps in a photochemical reaction which occur in time sequence: (1) Radiation, (2) Absorption, (3) Primary Reactions, and (4) Secondary reactions. We are mainly interested in substances which absorb photons in the 3000-7000Å spectral region (visible range).

Absorbers

Non-absorbers

O ₂	N ₂
O ₃	H ₂ O
NO ₂	CO
SO ₂	CO ₂
HNO ₂ - HNO ₃	NO ₂
RCH ₃	SO ₃ - H ₂ SO ₄
RCO	RCH
RCOO	RCOH
Particulates	RCOOH

(R denotes a radical)

- Oxygen

The most important photochemical reactions involve the very reactive single oxygen atom.

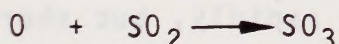
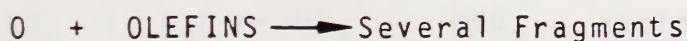
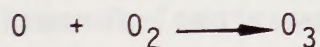

These atoms are produced by two main reactions:

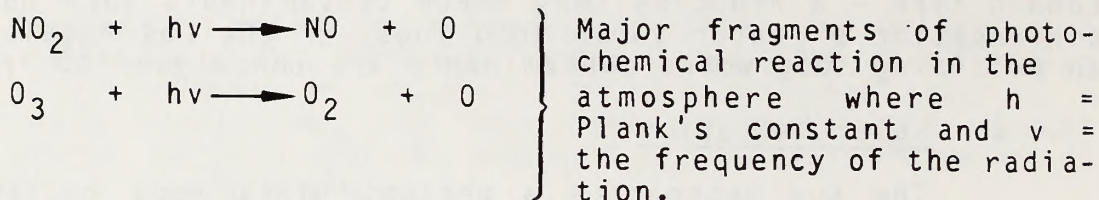

Oxygen atoms are produced at the rate of 150 pphm hr⁻¹, but because of their reactivity, their stationary concentration in air is usually only 1-2 ppht (parts per hundred thousand).

• Ozone

Ozone is very important as a reactant in photochemical type smog. It is produced through the photolysis of nitrogen dioxide and the reactive oxygen atom.

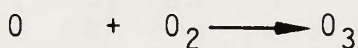

Ozone is a strong oxidizer and its main atmospheric reactions are:

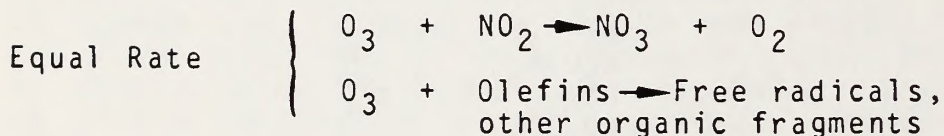
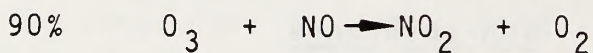

Sulfur Dioxide

Sulfur dioxide is the major sulfur containing compound formed during fuel combustion. Hydrogen sulfide is easily oxidized to sulfur dioxide in air, especially in the presence of sunlight. In sunlight, sulfur dioxide reacts with either atomic or molecular oxygen to form an aerosol, particularly if water vapor is present. This aerosol is dilute sulfuric acid when uncontaminated with particulates, which are found in reducing type smogs. Sulfur dioxide also reacts with organics to form various sulfonic acids which are also irritants. Relative humidity plays a very important role in the photochemical reactions of sulfur dioxide by determining particulate-aerosol formations.

Organic Compound Reactions

The range of classes of organic compounds emitted from various processes and industries is very wide. Most of the higher molecular weight products settle rapidly, but short carbon

chain molecules tend to be more reactive as ionic character outweighs the usual covalent nature of organic materials and they are very important as irritant precursors. Absorption of photons often leads to dissociation into free radicals - short fragments with extra electrons which are extremely reactive. Olefins, aldehydes, ketones, peroxides, are classes which easily absorb photons and form free radicals, and are among the usual products of combustion, especially from oil base fuels.

Nitrogen Oxide Reactions

Oxides of nitrogen are formed in practically all combustion processes in air, but the diurnal peaks and valleys of concentration are a matter of concern in air pollution studies due to the high buildup in the morning hours within urban areas as vehicular traffic reaches a peak. The sequence of reactions

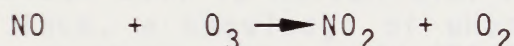
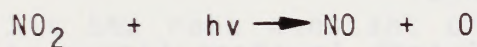

is the fastest, most important, and results in the highest concentrations of actual and potential irritant concentrations in air pollution - atmospheric chemistry. Second in importance, photochemically, is olefin photolysis and ozone - organic molecule interaction. Other nitrogen oxide reactions of less importance are:

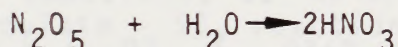

Non-photochemical Reactions

A secondary reaction following photochemical reaction which is very important is :

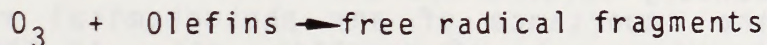

Olefins are the most important beginning class of organic compounds for production of irritants and phytotoxicants.

Reaction with water vapor:

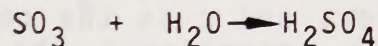
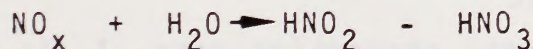

Other inorganic and organic classes of compounds are also emitted to the atmosphere such as flourides which quickly react with various surfaces, ammonia which forms acids, hydrogen sulfide which reacts with organics and forms sulfates, carbon monoxide which slowly oxidizes to carbon dioxide and organic amines which oxidize to acids. The above reactions are generally not of importance except in small localized areas.

Particulate Material Reactions

Particulate matter consists of an entirely different size category than we have examined thus far. As such, it provides reactive surfaces and can act as a third body and catalyst. Interaction with a particulate surface can cause either an energy level change or complete chemical change.

Examples of the former are:

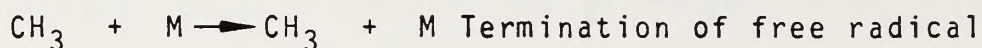

Examples of the latter are:

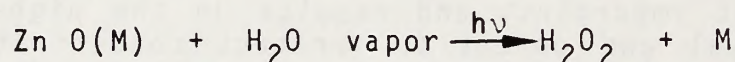

where:

λ = is the wavelength and

M = represents an energy-accepting third body

Catalyzed by photons:

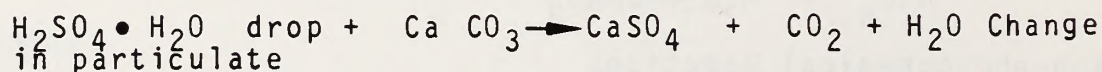
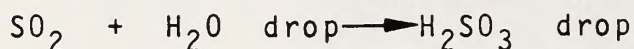

Kinetics in Atmospheric Chemistry

Without becoming involved in the rigors of kinetic theory, a few elementary definitions should be stated. The basis for determining the importance of any photochemical reaction, stationary concentration, rate of reaction, etc., is the Stark-Einstein Law which states that one photon must be absorbed to initiate photolysis. From this theory is derived the important equation:

$$k_a = \frac{I_a}{j c}$$

Where k_a is the specific absorption rate, I_a is the rate of absorption, j is a conversion factor, and c is the concentration of the absorbing substance. k_a represents the average fraction of absorbing molecules which receive photons per unit

time. Primary quantum yield is very important as it tells us what percent of molecules that absorb photons will actually react to the absorbed energy via a specific process. Absorption of a photon may result either in energy level change, shown by fluorescence, or chemical change, shown by dissociation or direct reaction. The rate of formation of excited molecules A' is given by:

$$+ \frac{d(A')}{dt} = I_a = k_a (A) = k_a c \quad \text{where}$$

(A) = c, the concentration of the absorber.

For secondary photochemical reactions rate constant is important. For a bimolecular reaction $A + B \rightarrow C + D$, the decrease in concentration of A will be:

$$- \frac{d(A)}{dt} = k_1 (A) (B)$$

where K, is the rate constant of the reaction. In general, the larger the rate constant, the more probable and more important part the reaction plays in the atmosphere.

Thus, a knowledge of what general reactions take place in the atmosphere under different meteorological conditions, can help answer questions concerning the relative importance of contaminating substances. From a meteorological point of view, relative humidity and percent possible sunshine are the most important parameters to consider. This is because nitrogen dioxide-olefin photolysis and the reactions which follow are sunshine dependent and the sulfur dioxide-particulate reactions are largely humidity dependent. Further consideration involves precipitation which functions as a removal method, and low wind speed which causes the atmosphere to function as a stable reaction vessel. Extremes of temperature either help catalyze photochemical reactions, as in Los Angeles, or enhance fog formation of particulate - SO₂ reactions, as in London.

The state of knowledge of atmospheric chemical reactions and interactions leaves a good bit to be desired as the subject is very complex. Experiments in all the areas discussed are increasing our knowledge and the total picture is slowly emerging.

A pollutant can be roughly defined as a harmful chemical or waste material which is discharged into the atmosphere or water. Pollutants add stress to the biosphere, thereby affecting the quantity, quality or diversification of populations. State and local governments have regulated air pollutants for many years, but the first federal legislation was not seen until 1955, with the establishment of an air pollution research program. Public awareness of air pollutant hazards has increased tremendously since that time, and culminated in the enactment of the 1977 Clean Air Act Amendments. As stated in the Act, the purpose of this legislation is "to protect and enhance the quality of the Nation's air resources so as to promote the public health and welfare" (CAAA, 1977). Falling under the umbrella of public health and welfare is not only man, but all air quality related values, including soils, vegetation, wildlife, watersheds, archaeology, and visibility. In general, all aquatic and terrestrial flora and fauna and their habitats must be evaluated to determine threshold levels, or the point at which a pollutant can no longer be tolerated by a population. Section 5.1 detailed the formation of air pollutants. This section will describe the effect of these pollutants on the environment.

As depicted in Section 2, the majority of BLM lands are situated within the 3000-6000 foot elevation range; however, areas as low as 1500 to 3000 feet and as high as 6000 to 10,000 feet are also found within the Susanville District. The major vegetation types concentrated in these areas include Pine, Douglas Fir, Fir, Lodgepole and Whitbark Pine, Redwood, Saltbush grass and sagebrush. While pollutant effects have been felt severely by California's agricultural crops, these will not be discussed to the extent of the aforementioned vegetation types, as they are not of primary importance to the BLM. Effects on fisheries and native animals will also be discussed to the extent that they have been researched. It is also valuable to note that effects of air pollutants have been seen in archeological sites, such as ancient Grecian ruins, and in geology throughout Europe and the Eastern United States. Although these later effects have not been seen or researched in California, they may become a serious future concern.

Particulates

Within the BLM lands in the Susanville District, man-made emission densities for particulates range from 2000-3500 tons per year. Particulates may be defined as dispersed matter in the liquid or solid phase. A few of the wide variety of chemical constituents of particulate matter are listed in Table 5.2-1. Individual particles range from 0.005 to 500 μ m in diameter. While emission control devices can remove up to 99% of stack particulate emissions, their efficiency becomes considerably lower for particles in the size range of 0-5 μ m. These particles, therefore, are more readily emitted and can be trans-

Table 5.2-1
General Manifestations of Trace Elements in Animals

Element	Target organs or characteristics of toxicity	Comments
Arsenic	Has been associated with increased incidence of lung cancer.	Non-accumulative in animals but has affinity for hair, nails, and skin.
Barium	Has strong stimulating effect on all muscles in acute poisoning.	Poorly absorbed with generally little retention in tissue.
Beryllium	Characteristic granulomatous changes of lung tissue is brought about by long-term exposure.	Via inhalation, beryllium is correlated with an interference in the passage of oxygen.
Cadmium	Is linked with the incidence of hypertension in experimental animals.	Accumulative in all animals and toxic to all systems and functions in humans and animals.
Cobalt	Causes changes in lungs typical of pneumoconiosis. Also causes induction of polycythemia in many species.	With increasing age, the body burden of cobalt diminishes.
Copper	Associated with induction of haemolytic disease, especially in certain species.	In excess, results in some accumulation in the tissue, especially in the liver.
Chromium	Hexavalent compounds extremely toxic to body tissue. Insoluble forms retained in lung tissue.	In particular, the respiratory tract and fat tissue accumulate this metal.
Fluoride	Contributes to dental fluorosis in animals.	Deposits in bone tissue.
Lead	Newly absorbed lead is mostly retained in the body as lead triphosphate, especially in liver, kidneys, pancreas, and aorta.	Has strong affinity to accumulate in bone tissue.
Manganese	Acute intoxication involves changes in the respiratory system, whereas chronic poisoning affects the central nervous system.	Most amounts taken into the body are retained, especially in liver and lymph nodes.
Mercury	Organic forms have effects on brain tissue. The inorganic form is more linked to damage to liver and kidneys.	Can bioaccumulate in tissues of animals.
Molybdenum	Associated with degenerative changes in liver cells.	Can accumulate in tissues.
Nickel	Associated with cancer of lungs.	Very poorly absorbed from gut.
Selenium	Associated with alkali disease in cattle.	Is converted in the body into a volatile compound which is eliminated through breath and sweat.
Vanadium	Is found to inhibit the synthesis of cholesterol and other lipids. Other complications leading to cardiovascular diseases are also prevalent.	Vanadium salts are poorly absorbed from the gastrointestinal tract.
Zinc	Intoxication produces either lung or intestinal tract manifestations.	Absorbed or injected zinc is incorporated at varying rates into different tissue, indicating varying rates of zinc turnover.

Source: Dvorak, 1978

ported over great distances. Also, this size range is easily passed into the lungs of man and animals, making these smaller particles the most deleterious.

The effect that particulate matter will evoke depends largely on its chemical composition. In general, most trace elements deposited on soil will remain in the surface layers, except in very acidic or sandy soils. While this accumulation serves to protect groundwaters from contamination in the short term, in time, natural processes such as surface runoff, erosion, and windblown dust may serve to contaminate aquatic biota. One of the most important factors in determining potential soil effects is the concentration of naturally occurring endogenous trace elements. Impacts of added particulates will be more severe in areas where endogenous concentrations are currently close to the tolerance limit for any population member. On the other hand, benefit in a deficient area may be gained by the addition of essential trace elements, such as copper, boron, molybdenum, zinc and manganese, (Dvorak, 1978).

Effects on vegetation will vary considerably. Visible effects range from chlorosis, necrosis and discoloration to stunting and deformation. These may be linked to changes in enzymatic reactions or metabolic processes, such as photosynthesis and respiration and will depend not only on the chemical composition of the particulate matter, but also on the exposure concentration, and plant species. In a natural vegetation area, such as the forests of the Susanville District, where the majority of the vegetation is recycled rather than consumed, concentration build-up will exceed that found in agricultural areas.

As trace elements collect in the edible plants the entire food chain will be impacted. Herbivorous wildlife are affected through ingestion and also by the loss of sensitive plant species within their habitat. These factors may contribute to reduced numbers of wildlife species or possibly the elimination of certain species from the affected environment. Ingestion, along with inhalation, are the two modes of entry of trace elements into animals. Several effects of these elements are detailed in Table 5.2-1.

Sulfur Dioxide

All land areas within the Susanville District, as shown in Figure 5.3-2, are unclassified or better than national standards for SO_2 . However, this classification does not preclude effects from being seen within this area. Sources of SO_2 and sulfur compounds include high sulfur fuel combustion (SO_2), anaerobic decomposition of plants material (H_2S), and the industrial production of sulfuric acid. Coal-fired power plants alone account for 40% of total U.S. sulfur-compound emissions. Highest levels of exposure from such plants may be expected in the Western U.S., where scrubbers are not used (Dvorak, 1977). Since

many BLM land areas contain major coal reserves, this may be an area of great concern in the future.

The effects of gaseous air pollutants such as SO_2 on plants and animals are typically classified according to the exposure. Acute effects are those related to exposures of short duration (up to one month) and comparatively high concentrations. Chronic effects are evoked when organisms are exposed to low-level concentrations for periods of one month to several years. Long-term effects are the result of exposures lasting for decades or longer. These are characterized by abnormal changes in the ecosystem or subtle physiological changes in the organism. Acute injury to vegetation from SO_2 exposure is characterized by collapsed marginal or intercostal leaf areas, which later become dried and bleached to an ivory color in many species, or brownish red or brown in other species. Chronic injury is seen as leaf yellowing from the margins to intercostal areas. Both acute and chronic injuries can result in death of the plant. Long-term injury may also occur without visible symptoms, but may be implied by subtle changes in the ecosystem (Dvorak, 1976).

Sensitivity to SO_2 will vary according to the plant species and microclimate in which it exists. Several vegetation types native to BLM lands in the Susanville District have been listed in Table 5.2-2, according to the sensitivity level as determined by the reference. Plants may also be affected in the following ways: increased respiration, decreased protein content and metabolism, decreased sugar, vitamin and starch content, decreased glucosidase activity and altered terpene activity.

Studies concerning SO_2 and SO_2 with NO_2 effects on desert-type vegetation of the Southwestern U.S. have been conducted by Hill, et al. (1974). The area studied included Utah and New Mexico at elevations of 4500 to 6500 feet. Using concentrations of 0.5 to 11 ppm SO_2 + 0.1 to 5 ppm NO_2 for 2-hour fumigation periods, the study ranked sensitivity according to Table 5.2-3. Studies have been ranked together as no synergistic effects were found. Common injuries appeared as leaf necrosis and interveinal patches of necrotic tissue on broad leaves. Color of injured tissue varied from tan, gray brown and yellow to rusty brown depending on the species. With desert plants, often the entire leaf was injured. Results of the study suggested that middle-aged and older leaves were more sensitive than younger, expanding leaves and years with unusually high rainfall could cause more severe injury to desert type vegetation (Hill, 1974).

Caldwell, et al (1976) also studied SO_2 effects on southwestern U.S. desert vegetation. Fumigation studies were conducted in the Catalina Mountains near Tucson at 7700 ft. Results were similar to those by Hill et al; (1974) however, Caldwell noted that SO_2 will injure vegetation to a maximum distance of 30 to 40 miles. Past that point, the plume will be too dilute to cause any effects. The most resistant species (Douglas Fir, Pinon Pine, and Arizona Ponderosa) all grow in

Table 5.2-2
 SO₂ Injury to California Native Vegetation

Common Name	Sensitivity	Reference
Pine, Jack & Red	Sensitive	Davis & Wilhour (1976)
Douglas Fir	Intermediate	Davis & Wilhour (1976)
Fir, Basalm & Grand	Intermediate	Davis & Wilhour (1976)
Pine, Lodgepole	Intermediate	Davis & Wilhour (1976)
Pine, Ponderosa	Intermediate	Davis & Wilhour (1976)
Pine, Western White	Intermediate	Davis & Wilhour (1976)
Fir, Silver	Resistant	Davis & Wilhour (1976)
Fir, White	Resistant	Davis & Wilhour (1976)
Pine, Limber	Resistant	USDA (1973)
Pine, Mugs	Resistant	Davis & Wilhour (1976)
Pine, Pinton	Resistant	Davis & Wilhour (1976)
Fir, Subalpine	Sensitive	Davis & Wilhour (1976)
Pine, Short Leaf	Intermediate	Treshow (1970)
Sagebrush, Big	Intermediate	Davis & Wilhour (1976)

Source: Dvorak, 1978

Table 5.2-3
Percent of the Total Leaf Area Injured by Different Concentrations
of SO₂ in Two-Hour Field Fumigation Studies

Species	Average percent injury						Number of replications					
	SO ₂						.5 ppm	1 ppm	2 ppm	4 ppm	6 ppm	10 ppm
	.5 ppm	1 ppm	2 ppm	4 ppm	6 ppm	10 ppm						
Abies concolor (White fir)		0		0	0			1		1	3	
Abies lasiocarpa (Alpine fir)					0	22					5	2
Acer glabrum (Rocky Mountain maple)		0		10	60			1		1	1	
Achillea millefolium (Yarrow)		0	0	0	16	38		1	1	2	5	2
Agoseris glauca (Mountain dandelion)		0	0	10	15			3	2	7	6	
Agropyron caninum (Wheatgrass)			0	0	0	78			1	1	5	2
Agropyron desertorum (Crested wheatgrass)					20						1	
Ambrosia sp. (Ragweed)		0	0	0	1	1		1	3	4	2	1
Amelanchier utahensis (Utah serviceberry)	0	0.2	3	22	33	80	1	3	3	1	3	1
Antennaria sp. (Pussytoes)			0	0					1	1		
Arabis pulchra (Rockcress)				0						1		
Artemisia ludoviciana (Louisiana sage)		0		0	21			2		1	4	
Artemisia tridentata (Big sagebrush)			0	4	9	2			2	5	7	3
Aster chilensis (aster)		0	0	1	5			3	1	6	4	
Astragalus utahensis (Locoweed)		2	0	30	50			1	1	2	2	
Atriplex canescens (Fourwing saltbush)				0	0					1	1	
Atriplex confertifolia (Shadscale)				0	0					1	1	
Betula occidentalis (River birch)				50						1		
Bouteloua barbata (Six-weeks grama grass)		0	0	0	0			3	2	7	9	
Bouteloua gracilis (Blue grama grass)					0						1	
Bromus ciliatus (Fringed brome)		0	0	0	13	96		2	3	5	2	1
Bromus inermis (Smooth brome)						0.6						1
Bromus tectorum (Cheatgrass)			0	0	0	10			1	3	3	1
Cercocarpus ledifolius (Curl-leaf mountain mahogany)					0.4	25					5	1
Cercocarpus montanus (Mountain mahogany)				5						2		
Chenopodium fremontii (Goosefoot)		0	2	5	7			5	3	5	6	
Chrysothamnus nauseosus (Big rubber rabbitbrush)				0	1	40				3	3	1
Chrysothamnus stenophyllus (Little-leaf rabbitbrush)				0						1		
Chrysothamnus viscidiflorus (Sticky-flower rabbitbrush)		0		0	5			2		1	2	
Cirsium undulatum (Thistle)		0		6	14			2		4	4	
Clematis ligusticifolia (Western virgin's bower)				0	0.2					1	1	
Cleome sp. (Beeplant)				0						1		
Cowania mexicana (Cliffrose)					0	3					1	1
Cryptantha humilis (Catseye)				0	15	80				1	1	2
Cynoglossum officinalis (Houndstongue)		0	0.4	8	16			5	4	15	7	
Descurainia californica (Tansy mustard)				0		40				1		1
Ephedra viridis (Mormon tea)		0		0	2	95		2		2	4	1
Equisetum sp. (Horsetail)		0	0	0	0			1	1	2	1	
Eriogonum racemosum (Buckwheat)		0		43	19			1		2	3	
Euphorbia serpyllifolia (Spurge)		0	0	12	15			5	2	9	10	
Eurotia lanata (Winterfat)				6	0					1	2	
Geranium richardsonii (White geranium)			3	7	86				2	2	2	
Gilia aggregata (Scarlet glia)			0.8	3	14				1	2	2	

Table 5.2-3 (cont.)

Species	Average percent injury						Number of replications					
	SO ₂						.5 ppm	1 ppm	2 ppm	4 ppm	6 ppm	10 ppm
	.5 ppm	1 ppm	2 ppm	4 ppm	6 ppm	10 ppm						
Gutierrezia sarothrae (Snakeweed)			0	0	21	78			4	2	13	3
Hackelia floribunda (Stickseed)		0		0				1		1		
Haplopappus nuttallii (Goldenweed)					0	100					1	1
Hedysarum boreale (Sweet vetch)			0	0	40	75			2	1	1	1
Hilaria jamesii (Galleta)		0	0	0	0	0		3	2	5	9	1
Hymenoxys richardsonii (Hymenoxys)				0						1		
Juniperus osteosperma (Utah juniper)					0	28					1	2
Juniperus scopulorum (Rocky Mountain juniper)		0		0	0	25		1		1	4	1
Lepidium sp. (Peppergrass)		0						1				
Machaeranthera canescens (Spiny-leafed aster)				25						1		
Mahonia repens (Oregon grape)		0		0	0			1		1	2	
Malacothrix sonchoides (Desert dandelion)				0						2		
Munroa squarrosa (False buffalograss)		0	0	0	0			3	2	7	9	
Oenothera sp. (Evening primrose)		6	12	5	3			3	1	3	1	
Opuntia sp. (Prickly pear cactus)					0						1	
Oryzopsis hymenoides (Indian ricegrass)	0.2	2	2	17	29	90	4	9	8	14	17	1
Oryzopsis micrantha (Ricegrass)				4						1		
Pachystima myrsinites (Mountain lover)					0						1	
Penstemon sp. (Penstemon)				15		70				1		1
Phacelia corrugata (Scorpion weed)				0						2		
Picea pungens (Blue spruce)			0	0	0				1	2	3	
Pinus edulis (Pinyon pine)				0	0.06	2				4	9	4
Pinus ponderosa (Ponderosa pine)				0	0	1				2	3	1
Poa pratensis (Kentucky blue grass)			0	0	7				1	5	3	
Populus angustifolia (Narrowleaf cottonwood)	0	0	2	11	20		3	6	2	5	2	
Populus tremuloides (Quaking aspen)	0	0	0	12	7	0	1	2	3	11	8	1
Pseudotsuga taxifolia (Douglas fir)				0	0.8					5	4	
Quercus gambelii (Gambel oak)					0	8					1	1
Rhus trilobata (Squawbush)					0.3	0					1	1
Rosa woodsii (Wild rose)		0	1	15	90	60		6	3	5	2	1
Salsola kali (Russian thistle)				7	3					3	2	
Senecio streptanthifolius (Groundsel)				0	8					3	1	
Silene menziesii (Catchfly)				0						1		
Sitanion hystrix (Squirreltail)			0						1			
Sphaeralcea sp. (Cutleaf globe mallow)			0	0.03	17	40				2	4	3
Sphaeralcea parvifolia (Globe mallow)	20	22	43	38	30		2	7	3	7	2	
Sporobolus cryptandrus (Sand dropseed)		0	0	0	0	0		3	2	8	7	1
Stipa occidentalis (Needlegrass)					0	73					4	2
Symphoricarpos oreophilus (Snowberry)		0.3	6	18	32			4	4	6	3	
Tragopogon dubius (Goatsbeard)			0	4	8				2	2	3	
Trisetum spicatum (Trisetum)						90						1
Viola sp. (Viola)					25						2	
Yucca sp. (Yucca)						0						1
Zygadenus paniculatus (Death camas)			0	0	13				1	1	2	

higher elevations and the three most sensitive species, (Gooding's Willow, Cocklebury, and Sunflower), all grow in low, wet areas. Humidity plays a role in determining the threshold value for SO_2 injury. Higher humidities tend to lower the SO_2 levels needed to create a response. Generally, injury was proportional to new growth and smaller, less developed individuals were more sensitive. Symptoms were visible within one and one-half days after fumigation. High temperature and wind increased symptom maturation (Caldwell, 1976).

Plants, in general, are more sensitive than animals to SO_2 injury; however, animals are impacted indirectly by changes in habitat or food species. Direct effects in animals also occur. Sulfur is known to inactivate enzymes, thus altering protein synthesis. Enzymes such as diastase, peroxidase and catalase are particularly sensitive. In man, the effects may be increased airway resistance, decreased mucus flow rate, increased susceptibility to respiratory infection and chronic respiratory disease. Six to ten exposures of 0.2 ppm for 10 seconds each has produced altered electro-encephalograms. Recent population studies indicate that, at lower concentrations, inhaled sulfuric acid and specific sulfates produce even greater irritability than from SO_2 (Coffin and Knelson 1976).

Studies by Colucci (1976) show deleterious effects to pulmonary function in laboratory animals with acute exposures of 6.75 ppm for two to three hours. Pulmonary dysfunction occurred with chronic concentrations of 4.86 ppm for several months. Epidemiological studies indicate that chronic exposures of 0.04 ppm can adversely affect human populations. It follows that animals with higher ventilation rates or more exposed mucosal tissue per body size would be more sensitive (Dvorak, 1976). Results of Colucci's studies may be reviewed in Table 5.2-4.

Another integral part of SO_2 emissions concerns the combination of SO_2 and nitric oxide as acid precipitation. The acidification of many freshwater lakes and streams has become an area of extreme concern in Northern Europe and Northeastern North America. The acidity of precipitation has been on the rise in this area since the early 1900's because of increased emissions of acid-forming sulfur and nitrogen compounds. This acidic precipitation can lower the pH of soils and natural waters causing mineral leaching and damage to many aspects of the biosphere.

Studies by Hendrey, et al (1976) show that the acidification of freshwaters produces many changes in the aquatic environment. In six Swedish lakes, where pH had decreased by 1.4 to 1.7 units during a forty-year period, bacterial activity had apparently decreased, leaving dense amounts of fungal hyphae on sediment surfaces. Decreased pH was believed to be the cause for the shift in dominance of organisms from bacteria to fungi, with the consequent decrease in oxygen consumption and interference with nutrient recycling by microdecomposers (Hendrey, 1976).

Table 5.2-4
Summary of Toxicological Experiments with Sulfur Dioxide (SO₂)^a

Species	Concentration (10 ⁵ µg/m ³)	Duration	Effects
Monkey	<0.034	78 weeks	None
Donkey	<0.078 <0.78		None Impaired bronchial clearance
Dog	0.13	21 hours/day for 620 days	None
Monkey	0.13	78 weeks	None
Guinea pig	<0.13	22 hours/day for 365 days	None
Dog	0.13	21 hours/day for 225 days	Increased pulmonary resistance
Rat	0.026-0.079	12 hours/day for 4 months	None
Mouse	0.18 -0.26	7 days	Increased sensitivity to pneumonia infection
Rabbit	0.26	3-10 days	Increased S-sulfonate clearance
Mouse	0.26	Up to 72 hours	Lesions in respiratory tract
Rat	0.26	6 hours/day, 5 days/week for 113 days	None
	2.6	6 hours/day, 5 days/week, for 22 days	40% mortality
	~15	6 hours/day, 5 days/week, for 12 days	~90% mortality
Guinea pig	0.26	6 hours/day for 20 days	None
Cat	0.52		Increase in pulmonary flow resistance
Rabbit	~0.52	14 and 62 hours	Formation of S-sulfonate
Mouse	13	5 min/day, 5 days/week for 300 days	Accelerated onset of neoplasia
Hamster	14	3 hours/day for 75 days	Increased pulmonary infection
Dog	13-14	2 hours/2 times/week for 4 to 5 months	Change in goblet cells of bronchi and bronchioles
Rat	13-78		Change in goblet cell release
Rat	26	Up to 6 weeks	None
	52	Up to 6 weeks	Bronchial damage
	104	Up to 6 weeks	Death within 22 days
Rat	78	6 hours/day for 10 days	Increased acid phosphatase activity
Rat	78	2 hours	Gastric inhibition
Mouse	≤78	10 exposures of 10 minutes, with 3 or 7 minutes recovery between exposures	Initial decrease in respiratory rate, then progressive return to preexposure rate; desensitization to successive exposures.
Mouse	Various		Sensitized mice to pneumonia infection

^aData extracted from summary of Colluci (1976) and presented in order of increasing concentration, except where there is more than one entry for a single experiment.

Source: Dvorak, 1978

The interference with microdecomposer activities impacts on invertebrates, as food availability and variety is decreased (Hendrey, 1976). Devastating effects have been seen in fish species. In Norway, huge amounts of adult salmon and trout have been killed in connection with spring snow melt or heavy autumn rains. Sweden has reported the extinction of the salmonid population, and severe effects in the roach, perch, and pike communities. Metal smelters in Sudbury, Canada, which emit 2.64 million tons of SO_2 annually, have been thought to be the cause of the rapid disappearance of lake trout, lake herring, white suckers, and other species in the La Coche mountain region during the 1960's. PH values as low as 4.5 were not uncommon in this region. In the Adirondack Mountains of New York State, intensive studies revealed pH levels less than five to be present in 51% of the higher elevation lakes, and 90% of these lakes were devoid of fish life. Species such as brook trout, lake trout, white sucker, brown bullhead and several cyprinid species were completely eliminated over a period of forty years. Cause of death at pH levels less than three may be the result of a coagulation of mucous on gill surfaces and subsequent anoxia. At pH levels of four to five, the cause may be a disturbance of the normal ion and acid-base balance. It appears that small fish are more sensitive than larger members of the same species. Smaller fish have a larger gill surface area per unit weight, which hastens ion fluxes. Age-specific mortality has not been clearly defined although there are indications that age may play a role in some species (Schofield, 1976).

The effect of acid precipitation on soils may be beneficial as well as harmful. Because it increases the amounts of sulfur and nitrogen, the added nutrient benefit may outweigh any deleterious effects. However, leaching of valuable soil minerals, such as calcium and manganese, and other cations, has been linked to acid precipitation. Inasmuch as soil structure, texture, and cation exchange capacity vary so widely, it is difficult to determine completely the effect that increased acid will create without first classifying the soil type. Susceptibility, as discussed by Malmer (1976), varies as follows. Natural soils with high pH and base saturation are usually highly resistant, along with soils rich in clay and organic colloids. On the other hand, acid and sandy soils and soil types that are transitional between brown earths and podsols will be more seriously affected by increased acidity. It is relevant also to bear in mind that acid precipitation may carry many other pollutants to the soil, which may increase or counteract expected effects (Malmer, 1976).

As soils are affected, biological effects will be seen on forest vegetation. Some species of lichens, which have the capacity to fix molecular nitrogen from the air, are quite sensitive to SO_2 and lose their nitrogen-fixing ability when subjected to acid precipitation. However, this may not be harmful to forest trees as they are not obligate nitrate plants. The addition of acid rain is also expected to cause the release of aluminum and heavy metal ions from the soil, which are toxic to many

plants. It is also felt that nitrogen is accumulating in forest soil, and this accumulated nitrogen is expected to be transformed to nitrate and leached after clearfelling or forest fires. The results of this net acidification during a short period of time is not clearly known. However, it is expected that this condition will contribute to a decreased growth rate of trees (Tamm, 1976). Although effects of acid precipitation have not been established in California, it is being monitored presently in the Ukiah District in order to evaluate trends for future consideration.

Nitrogen Oxides

Like SO_2 , coal-fired power plants are a major source of nitrogen oxides. These plants are responsible for 11% of the total nitrogen oxide emissions in the U.S. Other sources of atmospheric nitrogen include ammonia (NH_3) from biodecay and fertilizers, nitrogen oxides (chiefly NO and NO_2) from biochemical reactions within the soil, and also high-temperature combustion processes. Taken on a global scale, most NO_x is produced by bacteria, about 50×10^7 tons per year as compared to man-made sources which account for 5×10^7 tons per year. In the Susanville District, typical emissions densities for oxides of nitrogen are within the range of 3,000 to 2,000 tons per year (TPY).

Soils and plant life have not shown any detrimental effects of increased atmospheric nitrates at their present level (Noggle et al, 1978). In fact, atmospheric nitrate is beneficial because it restores the small quantities of nitrates lost in a mature ecosystem.

Animals and man, however, can be adversely affected by nitrous oxides as they are quite destructive to lung tissue. NO_2 is relatively insoluble in water and therefore is not scrubbed by tracheal and bronchial linings. This results in greater penetration into the lungs, interference with bacterial activity of macrophages, increased susceptibility to infection, bronchial inflammation, and loss of cilia. Long-term, low-level doses may result in an emphysema-type injury, decreased pulmonary compliance, and increased lung weight (Kavet and Brown).

Predicted worst-case NO_x emissions from a 2100 MWe generating station within about a one-half mile radius exceed 5.3 ppm for a short time period. Table 5.2-5 gives an indication of the adverse effects possible even at this level. Epidemiological studies indicate that humans may be adversely affected by chronic exposures to 0.53 of NO_2 . The effectiveness of extrapolating these data to wildlife in the region is uncertain (Dvorak, 1978).

It is known that NO_2 in combination with SO_2 can produce severe effects at levels where SO_2 or NO_2 alone would not produce a visible response. Since coal combustion in power plants accounts for approximately 40% of total sulfur compound emissions and about 11% of total nitrogen oxide emissions in the continen-

Table 5.2-5
Summary of Toxicological Experiments with Nitrogen Oxides (NO_x)^a

Species	Concentration (10 ⁵ µg/m ³)	Duration	Effects
<u>Acute exposures</u>			
Guinea pig	0.01-0.20	4 to 24 hours/day for up to 14 days	Elevated protein in urine
Guinea pig	0.04	Up to 21 days	Increased average area per alveolar wall cell
Mouse	0.02-0.30	Up to 17 hours	Impaired bacterial defense
Monkey	0.2 -1.0	2 hours	Decreased tidal volume, progressive histopathological damage
Rat	0.30-0.34	48 hours	Increase in Type II pneumocytes
Rabbit	0.16-1.2	3 hours	Impaired bacterial defense at all levels of exposure
Hamster	0.60-0.70	7 to 10 days	Bronchiolitic lesions
<u>Chronic exposures</u>			
Mouse	0.01	Up to 12 months	Reduction of functional lung tissue
Monkey	0.02	493 days	Slight to moderate emphysema
Monkey	0.04	14 months	Hypertrophy of bronchiolar epithe- lium in bronchiole
Rat	0.02	14 months	Marginal changes in epithelium
Guinea pig	0.02	6 months	Higher mortality
Rat	~0.06	9 months	Decrease in lung compliance
Rat	0.04	Lifetime	"Emphysema-like" injury suggested
Rat	0.04	Up to 360 days	Increase in number of cells prepar- ing to divide
Rat	0.34	Up to 7 days	
Rat	0.12	6 weeks	Interstitial edema, vascular congestion
Rat	0.20	90 days	Decreased body size
Rat	0.30	90 days	Decreased body size
Mouse	~0.80	Up to 8 weeks	Epithelial damage near terminal bronchioles
Hamster	0.9-1.1	10 weeks	Respiratory rate increased, hyper- plasia and hypertrophy in termi- nal and respiratory bronchioles

^aData extracted from summary of Ziskind and Hausknecht (1976) and presented in order of increasing concentration, except where there is more than one entry for a single experiment.

Source: Dvorak, 1978

tal U.S., it is important to look to these immediate areas for pollutant responses.

Carbon Monoxide

All land areas within the Susanville District are unclassified or better than national standards for carbon monoxide as shown in Figure 5.3-4.

The toxic properties of carbon monoxide have been known to man for quite some time. Unfortunately, studies involving environmental aspects such as soils, wildlife, vegetation and archaeology have not been published to the same extent as many other air pollutants. For this reason, carbon monoxide effects on man and mammals alone will be discussed.

Ninety-five percent of carbon monoxide emissions may be attributed to automobile exhaust and, because they are released near the ground, these emissions do not undergo substantial diffusion. This fact coupled with CO's lack of involvement in further atmospheric reactions to form secondary pollutants, accounts for the very high levels in urban areas. The situation is complicated further in that CO measurements in urban areas may be critically underestimated. Studies were conducted by Cortese and Spengler (1976) in the Boston area to determine the ability to represent carbon monoxide exposure by fixed monitoring stations. In this experiment, 66 non-smoking individuals carried portable CO samplers at breathing levels for the period October 1974 through February 1975. Results showed that four of the 66 volunteers, who commuted to work daily, were exposed to 37 ppm CO because of faulty automobile exhaust systems. This level is in excess of the National Ambient Air Quality Standard for one-hour 35 ppm. Considering the other volunteers, concentration of 5 to 20 ppm occurred 85% of the time, 5% were greater than 23 ppm and 1% were over 31 ppm. Comparison of these levels to fixed location monitors in the area, show that the mean one-hour personal exposure concentration (25.3 ppm) was 1.6 times greater than the fixed monitoring concentration (15.6 ppm) for all area stations. This difference may be due to the fact that CO concentrations at breathing level may diminish by 5 to 15% by the time they reach the usual monitoring height of 15 feet (Cortese, et al, 1976). This study would indicate that CO concentrations, as monitored, may actually be significantly higher in urban areas or on heavily traveled roadways.

Effects on small mammals may be derived through studies by Mordellet-Dambrine (1978) and Finelli, et al (1976). Mordellet-Dambrini ventilated guinea pigs and rats with 2.84% CO. After two minutes, tracheal pressure variations were seen and blood pressure and heart rate decreased within one to two minutes, respectively. Rats appeared to be more sensitive than guinea pigs to CO inhalation. It was postulated that their higher heart rate could trigger the higher sensitivity level (Mordellet-Dambrini, 1978).

Finelli, et al (1976) studied the effects of clean air, exhaust emissions with a catalytic converter, and carbon monoxide emissions on 20 male rats for a period of four weeks. CO levels of 57.5, 172.5 and 517.7 mg/m³ were used. During the exposure period, 18 animals were killed, and there was a dramatic loss in heart, spleen and body weight. A trend of lower serum cholesterol levels was significant in the rats exposed to the highest CO levels. These effects were not seen in the group exposed to the exhaust equipped with the catalytic converter as CO amounts had been greatly reduced (Finelli, 1976).

Parallel studies have shown that adult rats exposed to automobile exhaust without catalytic converters may also exhibit elevated hematocrit and hemoglobin, cardiac hypertrophy, loss in body weight and increased levels of serum lactate dehydrogenase. Low levels have also caused increased serum and aortic cholesterol in rabbits. This may be a factor in the development of arteriosclerosis in humans (Finelli, 1976). Also in humans, it is known to affect the heart, brain and muscle tissue most seriously because CO has a high affinity for hemoglobin and thus limits the amount of oxygen available to all body tissues, these three being extremely sensitive to oxygen deficiencies. CO has also been associated with reduced ability to perform vigilance tasks and reduced exercise tolerance (Cortese, 1976).

Any of these symptoms may also be seen in species native to the Susanville District. Possibly, symptoms may be more severe in animals with higher heart rates and more lung tissue relative to body weight. However, care should be taken in extrapolation of data.

Hydrocarbons

Hydrocarbon emissions in the Susanville District range from 500 tons per year in Sierra County to almost 5,500 tons per year in Plumas County. As in the case for carbon monoxide, studies involving hydrocarbons as an air pollutant are not as numerous as those concerning many other air pollutants.

There are three basic sources of hydrocarbons: animal, mineral and vegetable, such as municipally operated sewage treatment systems, industrial discharges from oil-dependent industries and decaying vegetation. Over 90% of major discharges of petroleum hydrocarbons escape from pipelines, tank ships, tank barges, marine facilities and onshore production storage facilities (Boyd, 1976).

At the 1977 American Petroleum Oil Spill Conference, it was reported that in California, concentrations of petroleum hydrocarbons were found in almost all benthic and sandy intertidal sediment samples collected in the Southern California borderland (Reed, 1977). As hydrocarbons collect in soils and water, an effect will be seen on algae and photoplankton. Retardation

of algae growth and inhibition of photosynthesis has been linked to the presence of petroleum hydrocarbons. A reported growth stimulation in photoplankton may be due to the slight carcinogenic stimulatory activity of low HC levels (Vandermuelen, 1976).

Effects of hydrocarbons on fish have been well documented by Adams (1975). Studies indicate that recreational vehicles, such as snowmobiles and motor boats, add dangerously high amounts of hydrocarbons to lakes. Death of fish may occur at levels of a few ppm and feeding, homing and reproduction are disrupted at levels of 10 to 100 ppb. These exhaust hydrocarbons concentrate in fatty tissue such as lateral line muscle and visceral fat. These compounds remain in the tissues and are passed to higher animals through the food chain (Adams, 1975). Further discussion of hydrocarbon effects on fish will be included in a subsequent section as this experiment also involved lead values.

Ozone

Hydrocarbons and nitric oxides in the presence of sunlight are known to produce ozone. Automobile exhaust, therefore, may be considered as a primary source of the precursors which give rise to oxidant. High ozone levels have been found not only in the urban environment but also in rural areas, on mountain tops, and at night. The reason for this ozone build-up is not fully known; however, it is believed that ozone or its precursors are being transported long distances or there may be a natural source of hydrocarbons and nitric oxides within forests and swamps, such as terpenes and methane. All areas within the Suanville District are unclassified or better than national standards.

Ozone is known to reduce photosynthesis in plants, thereby reducing the nutrient value of the plant. Studies of air pollution damage to the forests of the Sierra Nevada Mountains by Williams et al (1974), indicated widespread oxidant-caused injury to conifers. Especially susceptible were the ponderosa and Jeffery pine as measured by the extent and intensity of chlorotic mottle on current year needles. Since ozone is dose-accumulative for a variety of sensitive plants, a concentration of 0.06 ppm over a five-month growing season would produce chlorotic mottle on current year needles of the ponderosa pine. It should be noted that this quoted level is within the federal standard of 0.12 ppm (Williams, 1977).

Results of the 1974 Sierra Nevada field survey showed ozone injury to be most abundant in the mixed conifer forest types located from 6000-8000 ft. in elevation. However, injuries at mid-elevation, (4000-6000 feet), where many BLM lands are located, tended to be more severe. These studies indicate that ozone injury is dependent on elevation. At mid elevations, where inversion levels are often found, injuries will be most severe. At higher levels, where ozone is quite abundant, injuries are

more prevalent (Williams, 1977). Injuries to other species are detailed in Table 5.2-6.

The California Department of Agriculture yearly assesses damage to vegetation as caused by air pollution. In their 1970 summary, Millecan (1971) details the history of ozone damage to California forests. In the early 1950's in the San Bernardino National Forest, several pines began to turn chlorotic and drop needles. Ponderosa and Jeffery pine were particularly involved. In 1963, it was first suggested that ozone might be the cause. Later, in 1969, aerial surveys by the Forest Service and University of California at Riverside revealed the extent of ozone damage. More than 161,000 acres of the ponderosa and Jeffery pines in the San Bernardino National Forest, an estimated two-thirds of the trees, were damaged by ozone. Of these, 3% were dead, another 15% were severely affected, and 82% were moderately or lightly affected (Millecan, 1971). Damage estimates have also been assessed by the Statewide Air Pollution Research Center of the University of California. Figure 5.2-1 reveals the extent of oxidant injury as seen in 1974. Elevations over 8000 feet were not considered in this study.

The Forest Service has been assessing ozone injury since 1974. A recent survey by Pronos et al (1978) revealed the extent of ozone injury in the Sierra and Sequoia National Forests as depicted in Figure 5.2-2. The worst injuries found were considered to be moderate and these were generally found at elevations of 4000 to 7000 feet on the Front Range mountains west of the San Joaquin Valley and along major river drainages. However, a quick comparison of this data to photochemical levels found in the San Bernardino National Forest show that the ozone levels of the southern Sierra do not even approach the levels found in Southern California forests as shown in Table 5.2-7 (Pronos, 1978).

Impacts of ozone on man, animals and other air quality related values have not been studied to the same extent as with vegetation. However, ozone has been found to attack the cell membrane, breaking double bonds and removing hydrogen atoms. In humans, this process acts as a bronchoconstrictor, whereby less air reaches the lungs. There is increased coughing and breathlessness, and lung elasticity is decreased. Also, there is damage to alveolar macrophages in the presence of high concentrations of ozone, increasing the susceptibility to infection and cases of pulmonary edema. With wildlife, we can expect these effects to be seen to an even greater degree, as injury in most cases is more severe in animals with more respiratory tissue per body weight.

Lead

The thirty-day standard for lead is 1.5 ug/m^3 . Within the Suanville District, no violations of this standard were recorded in 1977. Environmental sources of lead include the petroleum, paint and ceramic industries, and coal combustion.

Table 5.2-6
Site Characteristics and Extent of Ozone Injury

Location	Elevation (meters)	Topography	Site	Species with symptoms	Land use
Delilah LO	1564	Ridge	Flat, Dry	Ponderosa (PP)	National Forest (NF)
Mt. Sampson	1623	Ridge	Steep	PP	NF, Private
McKensie Ridge	1600	Ridge	Dry	Black Oak (BO)	
			Flat, Dry	PP, BO	NF
Converse Basin	1577	Basin	Mesic	PP, Sugar Pine (SP)	NF
				Giant Sequoia (GS)	
Hume Lake	1577	Basin	Mesic	PP, SP, Jeffery Pine (JP)	NF
Boyerden Cave	970	Canyon Bottom	Dry, Steep	PP	NF, National Park (NP)
Park Ridge	2199	Ridge	Steep, Rocky, Moist	PP, JP, SP, White Fir (WF)	NP
Buck Rock	2578	Ridge	Steep, Rocky	JP	NF
Weaver Lake	2669	Flat	Dry	Lodgepole Pine?	
				JP, Lodgepole Pine?	NF
Whitaker Expt. Forest	1638	West Slope	Moist	PP, BO, WF, SP, GS	Univ. of Calif.
Pinehurst	1095	West Slope	Dry	PP, BO, WF	NF, Private
Badger F.S.	1000	Flat	Dry	PP, BO	NF, County, Private
Sierra Glenn	970	Flat	Dry	PP	Private, County, State
Eshom Creek	1517	Variable	Moist	PP, BO	NF
Eshom Point	1517	Ridge	Dry	PP, BO	NF
Skagway Grove, Muir Grove	1517	Flat	Moist, Rocky	JP	NP
Lodgepole RS	2038	Flat	Moist, Rocky	JP, LP	NP
Crystal Cave	1456	Flat	Mesic	PP, BO, WF	NP
Giant Forest	1911	Flat	Mesic	JP, BO	NP
Colony Mill RS	1638	Ridge	Dry	PP, WF, BO	NP
Moro Rock	1880	South Slope	Mesic	PP	NP
Crescent Meadow	1914	Meadow	Mesic	JP	NP
Milk Ranch Peak	1897	South Slope	Dry	PP, WF, SP, BO	NP
Mineral King	2254	Canyon Bottom	Mesic	JP	NF

Source: Williams, 1977

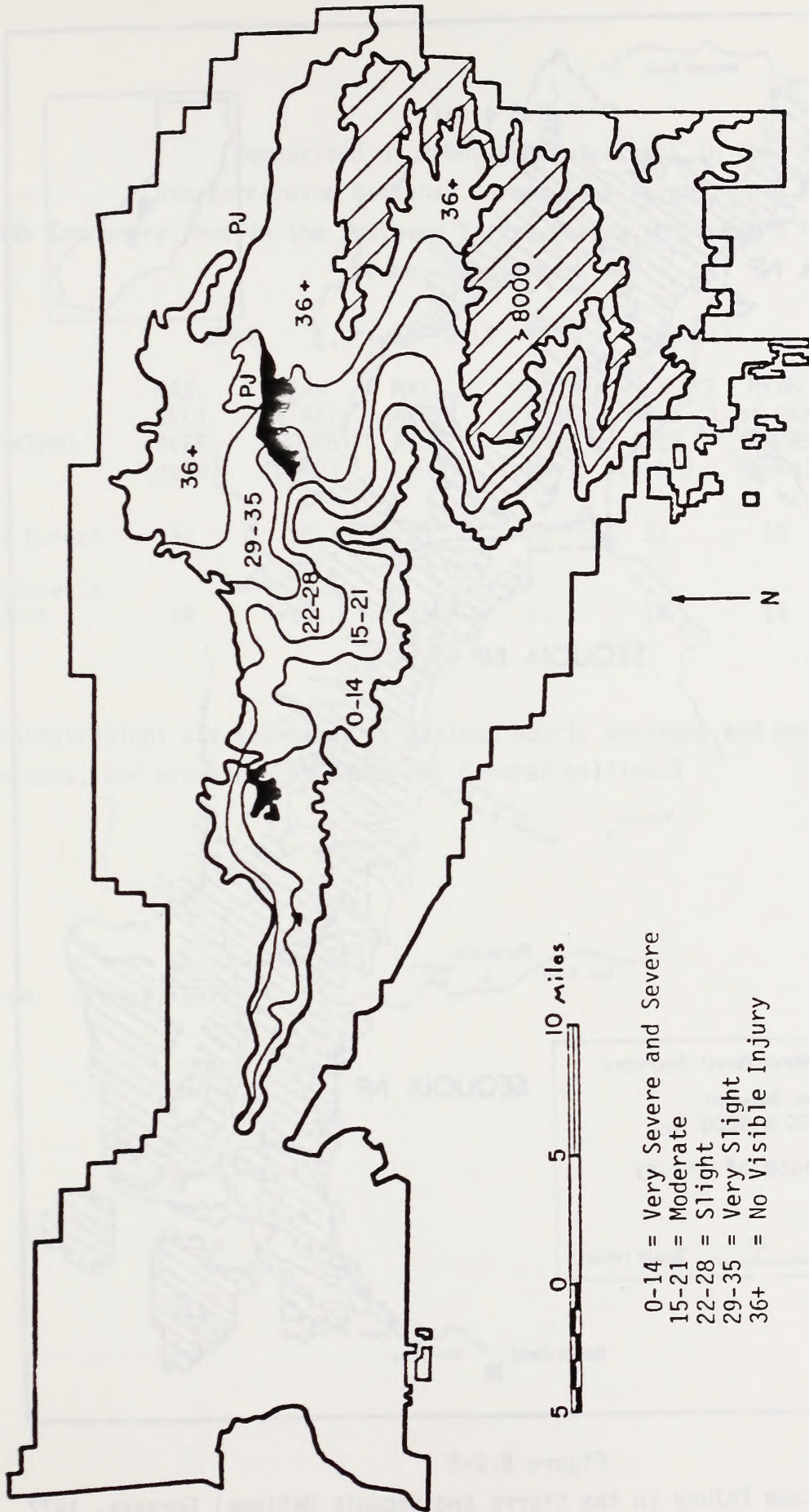

- 0-14 = Very Severe and Severe
- 15-21 = Moderate
- 22-28 = Slight
- 29-35 = Very Slight
- 36+ = No Visible Injury

Figure 5.2-1

Preliminary Map of the Extent and Severity of Oxidant Injury to Ponderosa and Jeffrey Pines in the San Bernardino National Forest (1974)

Source: Taylor, 1974

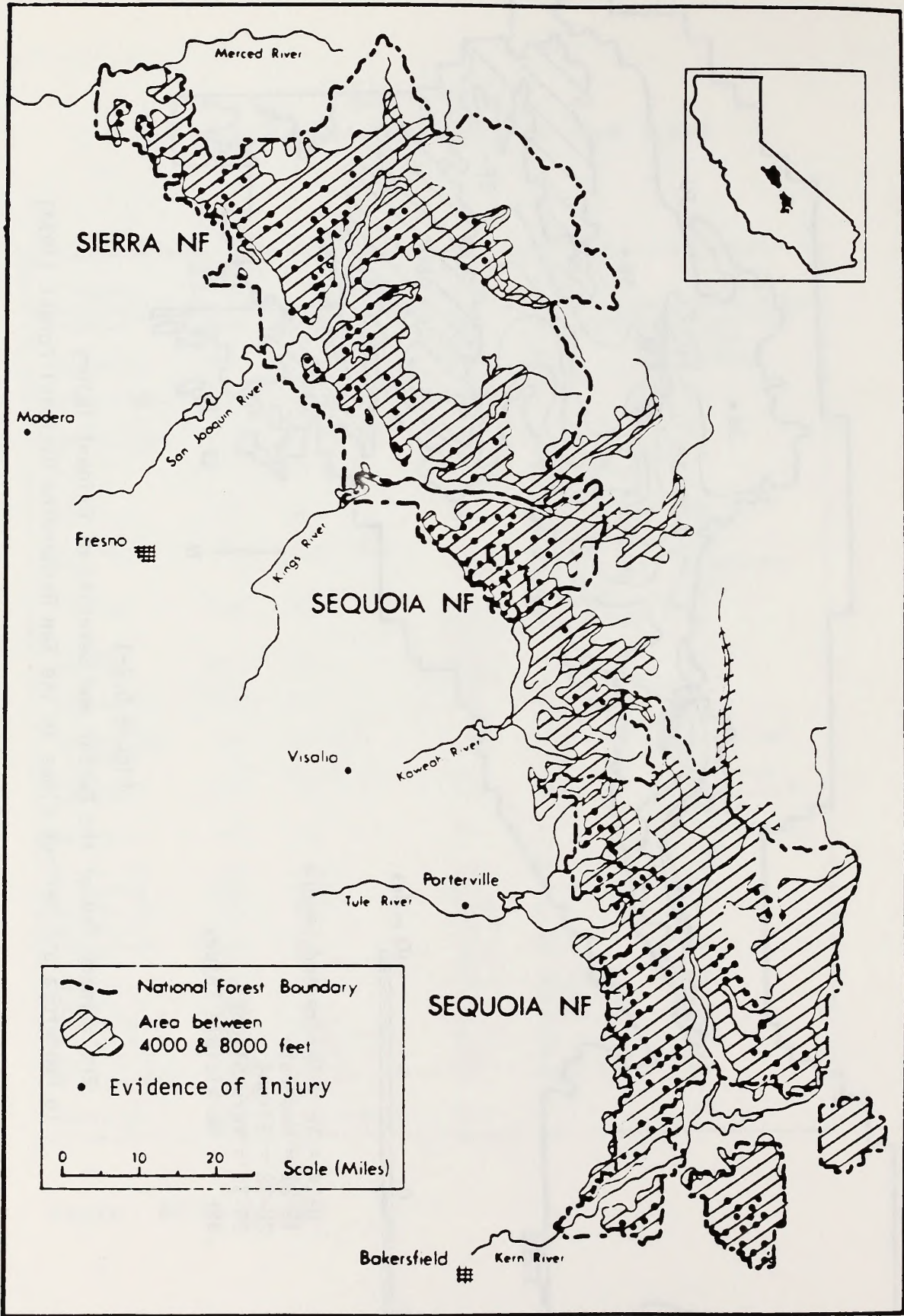

Figure 5.2-2

Location of Ozone Injury in the Sierra and Sequoia National Forests, 1977

Source: Pronos, 1978

Table 5.2-7

Comparison of Ozone Concentrations in the
 San Bernardino National Forest (Sky Forest, 5640 feet)
 With Concentrations in the Southern Sierra Nevada (Whitaker's Forest, 5400 feet)
 June - September 1977

LOCATION	JUNE		JULY		AUGUST		SEPTMEBER	
	MAX. HRLY. AVER. (pphm)	MEAN of MAX. HOURS (pphm)	MAX. HRLY. AVER. (pphm)	MEAN of MAX. HOURS (pphm)	MAX. HRLY. AVER. (pphm)	MEAN of MAX. HOURS (pphm)	MAX. HRLY. AVER. (pphm)	MEAN of MAX. HOURS (pphm)
Sky Forest	32	20	30	22	33	19	24	14
Whitaker's Forest	14	10	15	11	14	11	13	9

(Concentrations are expressed as maximum hourly averages and means of maximum hourly averages, and are shown as parts per hundred million.)

Source: Pronos, 1978

Lead has become a serious environmental pollutant to the agricultural industry and is a major concern in the vicinity of major roads, as lead collects and accumulates in the soil. To date, plants show no toxic effects, and lead absorption by plants is insignificant. Concern, however, stems from the rise in lead content of plants and in animal feed, for these accumulations will affect the entire food chain (Keller, 1977)

As lead accumulates in the soil, long-term changes in productivity, decomposition, nutrient cycling, and insect and microbial activities may be seen. In the case of the Hubbard Brook Experimental Forest in Central New Hampshire, lead is accumulating at the rate of 0.67 pounds per half acre per year. Sources of lead measured include precipitation, winter snow and stream water. The soil and especially forest floor humus was found to be the major sink for lead, while lead uptake in vegetation was quite low. The entire system, however, is functioning to remove lead from the atmosphere and hydrologic systems and place it in the soil system. With this current input rate, the doubling time for lead concentration in forest humus would be only 50 years and since lead deposits from the atmosphere have a mean residence time of 5000 years, long-term concentration should be carefully evaluated (Siccama, et al, 1978).

Effects of lead accumulations on fish have been studied by several investigators. Hodsons, et al (1978) has shown that lead uptake in rainbow trout is a function of the pH of the water. Blood lead concentrations increased by a factor of 2.1 as pH decreased by 1.0 unit. Consequently, lead sensitivity increased with low pH levels. The author suggested that low pH increases the permeability of the gills. Sublethal concentration of lead for a period of three to six months may cause spinal deformities. Lead is also known to cause behavioral changes in fish at 70 ppb and death at 0.3 ppm. Therefore, pH should be monitored in streams known to have high lead values (Hodson, 1978).

Badsha and Sainsbury (1977) have studied first year whittings in the Severn Estuary and feel that bioaccumulations are functions of the food chain rather than respiration and gills. Therefore, bottom feeders would be expected to accumulate relatively higher lead amounts than other types of predators. Once ingested, lead is not rejected and slowly increases (Badsha, et al, 1977). Effects on fresh water fish may be quite similar according to experiments by Rehwoldt, et al (1978) in the fresh water stretch of the Hudson River system. In this study several species of fish were caught and lead levels were compared to those of preserved samples. Results are given in Table 5.2-8 and indicate that lead levels are time independent in a relatively clean system such as the Mid-Hudson (Rehwoldt, 1978).

Studies by Adams (1975) involve the effects of lead and hydrocarbons on brook trout. Increasing amounts of these two

Table 5.2-8
Average Values (m/g) for Lead in Dry Weight

<u>Common Name</u>	<u>Source</u> *	<u>Pb</u>
Alewife	MC 10 (1976)	0.30
	VC 2 (1953)	0.61
Atlantic Sturgeon	MC (1976)	0.82
	NYS 5 (1924)	0.71
Fundulus	MC 21 (1976)	0.51
	VC 4 (1953)	0.62
	NYS 3 (1936)	0.41
	AMNH (2) (1973)	1.10
Small Mouth Bass	MC 11 (1976)	1.06
	NYS 3 (1936)	0.99
Spottail Shiner	MC 17 (1936)	0.59
	VC 5 (1953)	0.69
	AMNH 2 (1973)	0.77
Striped Bass	MC 14 (1976)	0.92
	NYS 2 (1936)	0.40
	AMNH 5 (1973)	0.21
Sunfish	MC 23 (1976)	0.25
White Perch	MC 26 (1976)	1.06
	VC 2 (1953)	1.02
	NYS 1 (1936)	0.80

* MC Marist College
 VC Vassar College
 NYS New York State Museum and Science Service
 AMNH American Museum of Natural History

Number after source is sample size
 Number in paranthesis is year caught

Source: Rehwoldt, et.al., (1978)

pollutants are released to the aquatic environment by snowmobiles and outboard motors each year and are attracting much attention. Towle's Pond in Freeport, Maine, served as the site for several experiments. Water samples in November 1971 showed 4.1 ppb lead and no detectable hydrocarbons as a baseline concentration. Through the winter seasons of 1971 and 1972, 56.8 liters of gasoline were burned in snowmobiles operating on the pond. During ice-out, lead levels increased to 88 ppb in 1972 and 135 ppb in 1973. These lead levels decreased rapidly within 72 hours of ice-out and returned to near normal within six days. Lead levels in exposed fish were 15.7 and 8.8 times those of control fish in 1972 and 1973, respectively. Four fish died during the first six hours of the 1973 experiment. Cause of death has been attributed to low oxygen levels in the pond during that period. Hydrocarbon levels ranged from 1 to 10 ppm and an oil slick was visible on the pond for one week after ice-out each year. Levels in exposed fish ranged from 0.1 to 1 ppm. Laboratory study revealed highest lead levels occur in the digestive tract (3.3 times that in control groups) and lowest in the gills, which may further indicate that bottom predators may be seriously affected by increasing lead levels. Elevated lead levels were also found in muscle skin and gills (Adams, 1975).

The pathological effects of lead in small mammals are detailed in reports by Roberts, et al (1978). Two abandoned metaliferous mines in Wales were chosen as the sites for soil, vegetation and mammal tissue measurements to determine lead accumulations. The area was typified by sparse natural vegetation, with a limited range of species, as few populations could survive the heavy metal concentrations in the soil. Table 5.2-9 indicates the lead amounts found in the soil, vegetation and invertebrate populations. Small mammals were caught in the area and examined for lead content. Vegetarian feeders were found to have the highest level concentrations and insectivorous mammals the least. In these mammals, bone and kidney tissues had the highest lead concentration, and the liver, brain, and muscle tissues had the least. This supports the generally accepted idea that the skeleton is the main long-term storage site for lead (Roberts, 1978).

Mice were fed lead acetate at levels of 0.1% and 4.0% in experiments by Eyden, et al (1978), to determine toxicity. The animals suffered weight reductions, increased sperm abnormalities, early hair loss, lethargy and reductions in mean survival time. Symptoms were dose-dependent and the authors suggested that death may be attributed to internal organ malfunction resulting from enzyme interference, lack of nervous or hormonal infection from depressed immunological competence (Eyden, 1978).

Lead is also known to accumulate in humans within the blood, bones, urine, aorta, teeth, kidneys and liver. It has been associated with anemia, arteriosclerosis, diseases of the central nervous system, bone deterioration, kidney failure, chromosome aberrations, and brain damage. It is also known that

Table 5.2-9

LEAD CONCENTRATIONS ($\mu\text{g/g}$ dry weight) IN SOIL, VEGETATION AND INVERTEBRATES (mean \pm standard error, number of samples in brackets)

	Vegetation Lead	Invertebrates Lead	Surface Soil Lead
Mine A	120 \pm 5.40(8)	61.9 \pm 14.5(6)	8430 \pm 2050(9)
Control	20.8 \pm 3.89(8) ⁺	18.4 \pm 1.87(6) ⁺	96.3 \pm 24.4(10) ⁺
Mine B	249 \pm 33.7(9)	81.7 \pm 18.6(5)	14010 \pm 6160(7)
Control	28.9 \pm 2.73(9) ⁺	22.3 \pm 4.79(6) ⁺	78.0 \pm 10.1(8) ⁺

⁺ Denotes statistical significance at $p < 0.001$ (NS = $p > 0.05$).

Source: Roberts, 1978

lead will pass through the placenta in pregnant women. Most serious effects may be seen in young children, ages one to four, as this is the time for normal development of the central nervous system and bone tissue. Yankel et al (1977) observed blood lead levels in young children living near a lead smelter in northern Idaho and found amounts as high as 70 mg Pb/100ml. Ambient air, soil and dust lead levels were attributed to be the major cause for the elevated lead levels. Air exposure alone explained 55% of the variance (Yankel, 1977).

This section has detailed the effects of various pollutants on air quality related values. Whenever possible, environmental concerns typical of the Susanville District were stressed. Where data was lacking, similar species or areas were described. Relating these data to the Susanville District may help to point out critical areas for immediate study or future areas of concern.

5.3 BASELINE AMBIENT AIR QUALITY

The Susanville District encompasses portions of two air basins as described in Section 4.8 - Northeast Plateau and Mountain Counties. Air quality monitoring in the district is concentrated in major cities for most of the pollutants, with an expanded network for the monitoring of total suspended particulates (TSP). The existing monitoring network is shown in subsequent figures in conjunction with the pollutant-specific attainment status for each county.

The California Air Resources Board (CARB), in accordance with the requirements of the Clean Air Act Amendments of 1977, has classified each county in terms of attainment of the National Ambient Air Quality Standards (NAAQS). Air quality regulations are discussed in considerable detail in Section 6; however, a review of the attainment status of counties within the Susanville District provides an excellent means for defining baseline ambient air quality. Figures 5.3-1 through 5.3-5 show the current status for each pollutant as designated for counties in the Susanville District. The figures illustrate which areas have been designated as non-attainment, cannot be classified, or better than national standards for total suspended particulates and sulfur dioxide. For oxidant, carbon monoxide, and nitrogen dioxide, areas with sufficient data and poor air quality would be designated as non-attainment. Those areas with good air quality or insufficient data have been categorized as "cannot be classified or better than national standards." Since the unclassified areas denote the lack of sufficient baseline air quality data, these maps also indicate which counties require additional monitoring stations to determine their status and thus their problem areas.

Baseline Levels

Ambient air quality values for 1975 for selected stations can be found in Appendix D while long-term baseline data are presented in Appendix E. Values are available for total suspended particulates only, as other pollutants were not monitored in the Susanville District during this time period. The listings include the number of observations, the yearly high and the arithmetic and geometric means with their standard deviations. The frequency with which standards are equalled or exceeded is also provided for each station.

1977 baseline ambient air quality data for total suspended particulates have been summarized in Figures 5.3-6. This parameter has been selected for graphical presentation and detailed analysis as it is the most readily available air quality data and provides a good representation of the effects of both industrial and agricultural (or outdoor) sources.

Data is presented as contours of annual average values based upon available data for monitoring stations at locations as

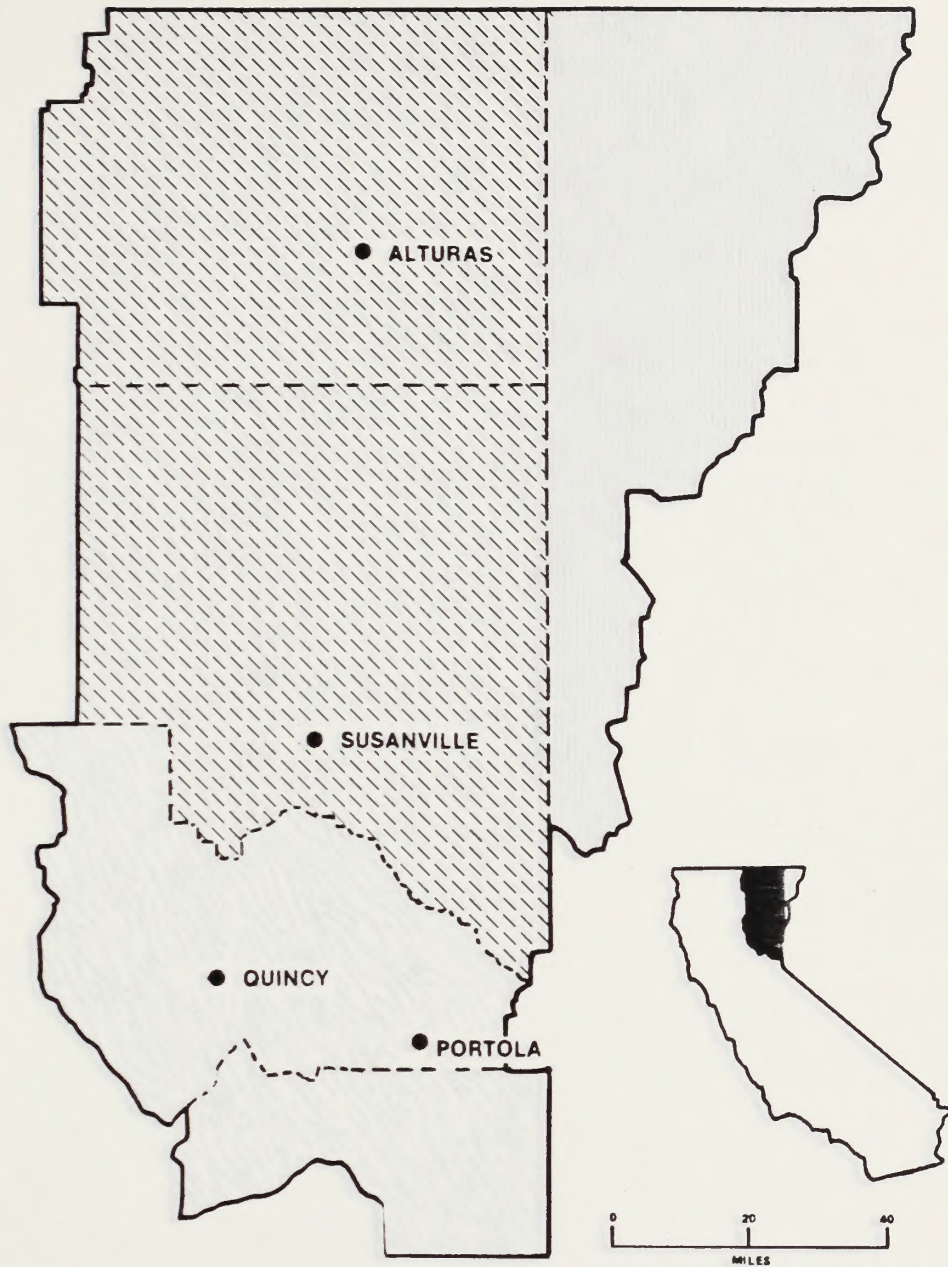

- Better than National Standards
- Cannot be Classified

Figure 5.3-1
Susanville District TSP Classifications

Source: Federal Register, March 1979

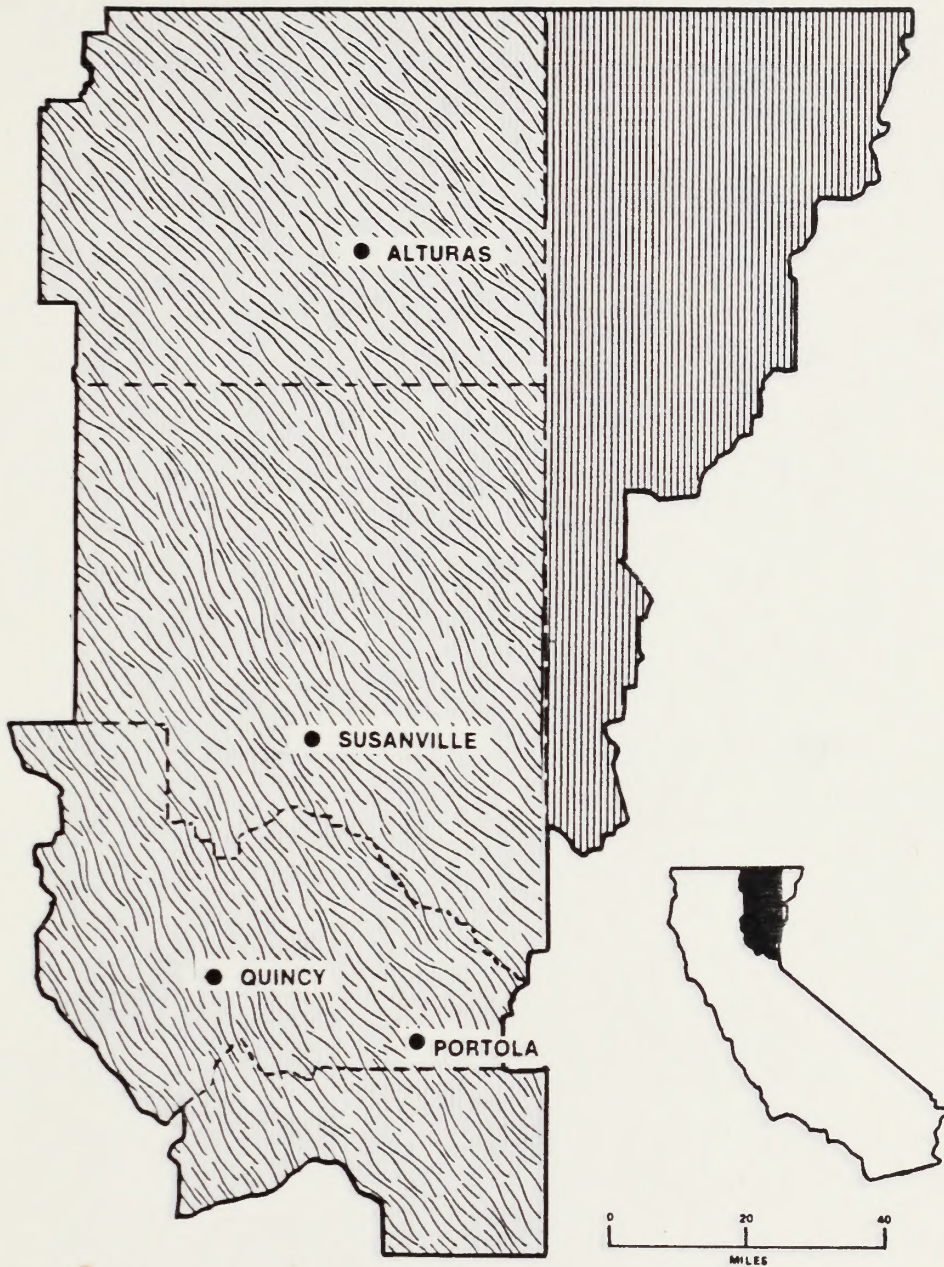



-  Cannot be Classified
-  Better than National Standards

Figure 5.3-2
Susanville District SO₂ Classifications

Source: Federal Register, 1979



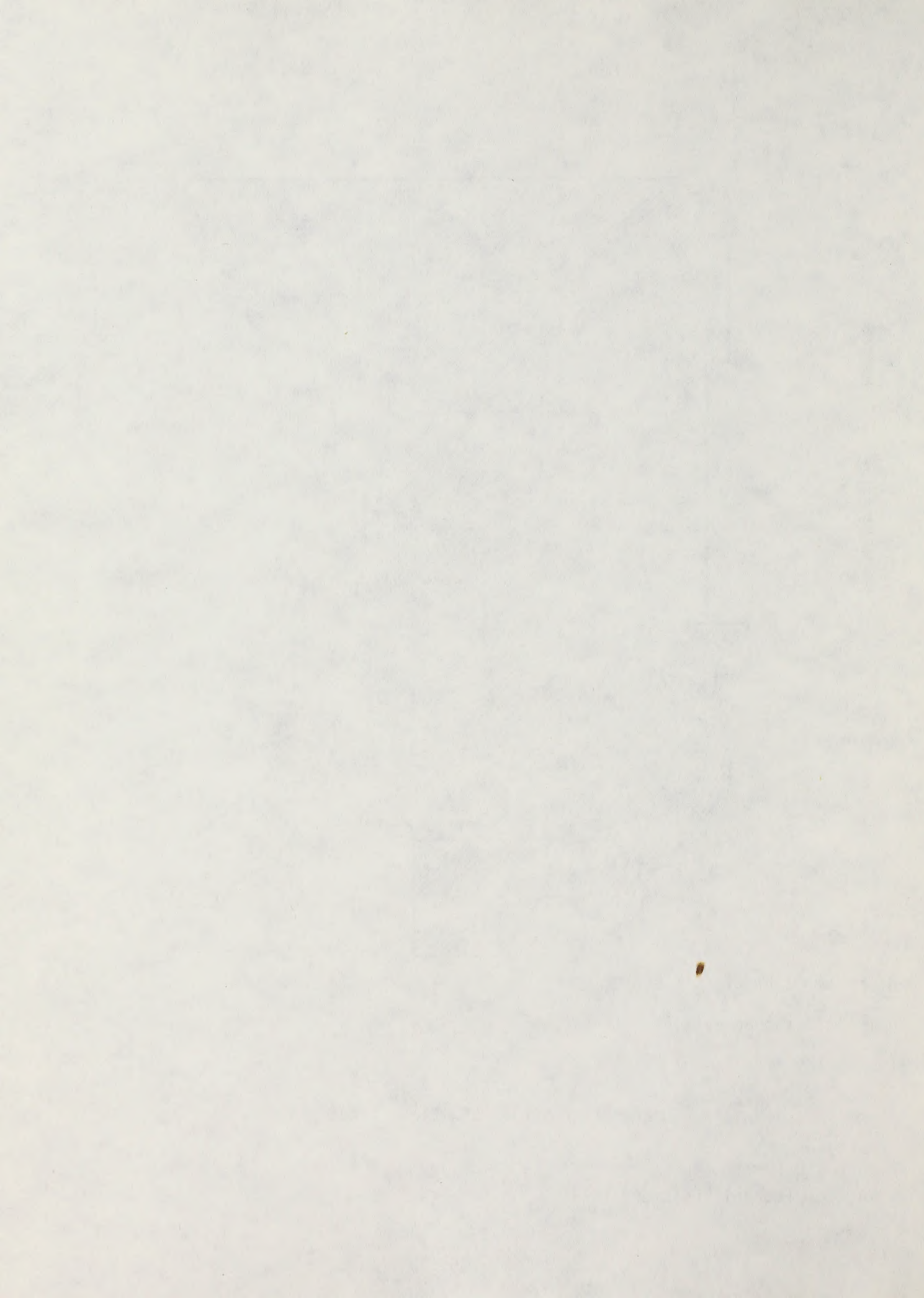
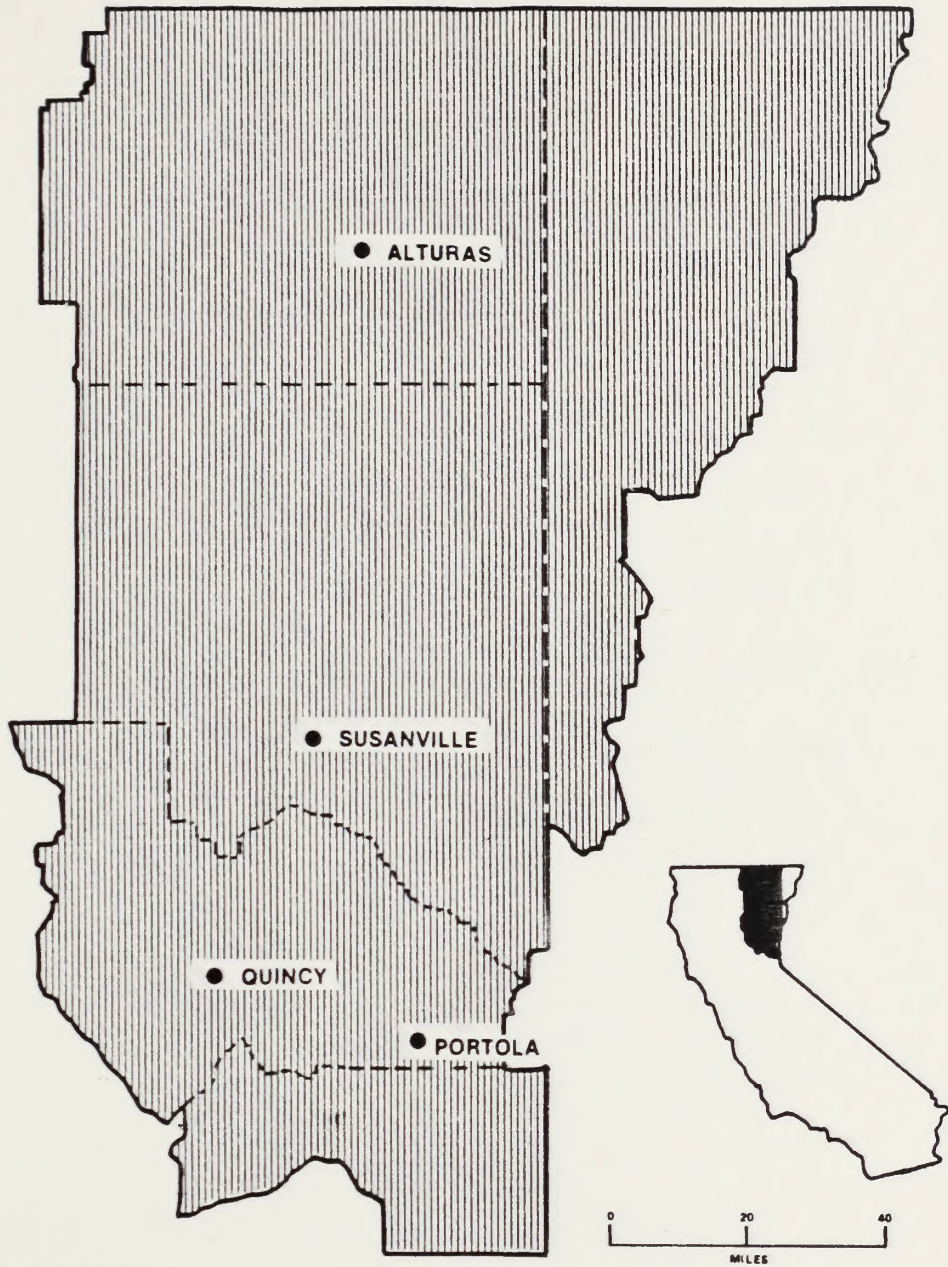

Cannot be Classified or
Better than National Standards

Figure 5.3-3
Susanville District NO₂ Classifications

Source: Federal Register, March 1979

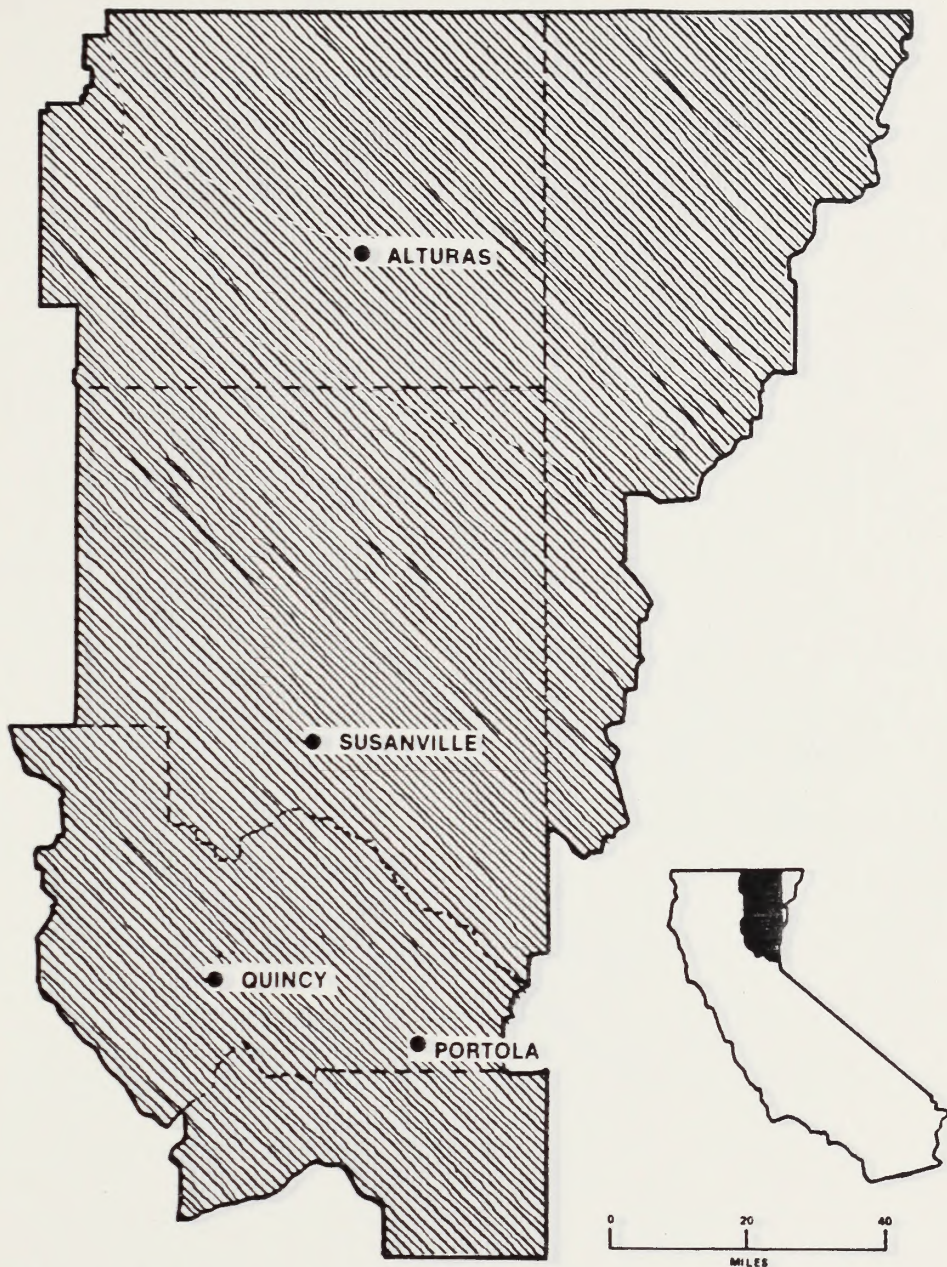

 Cannot be Classified or Better than National Standards

Figure 5.3-4

Susanville District CO Classifications

Source: Federal Register, March 1979



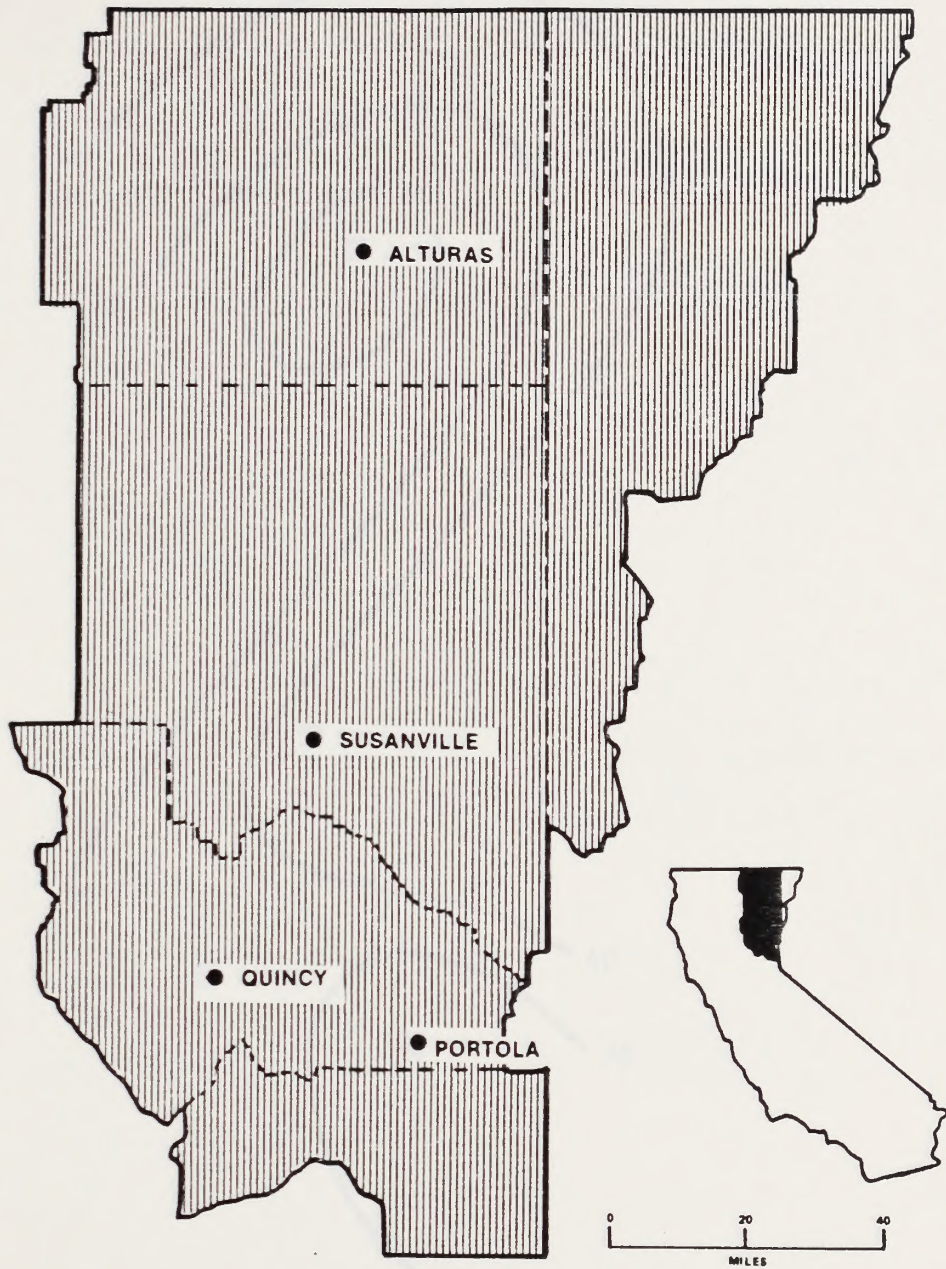

 Cannot be Classified or
 Better than National Standards

Figure 5.3-5
 Susanville District Oxidant Classifications

Source: Federal Register, March 1979

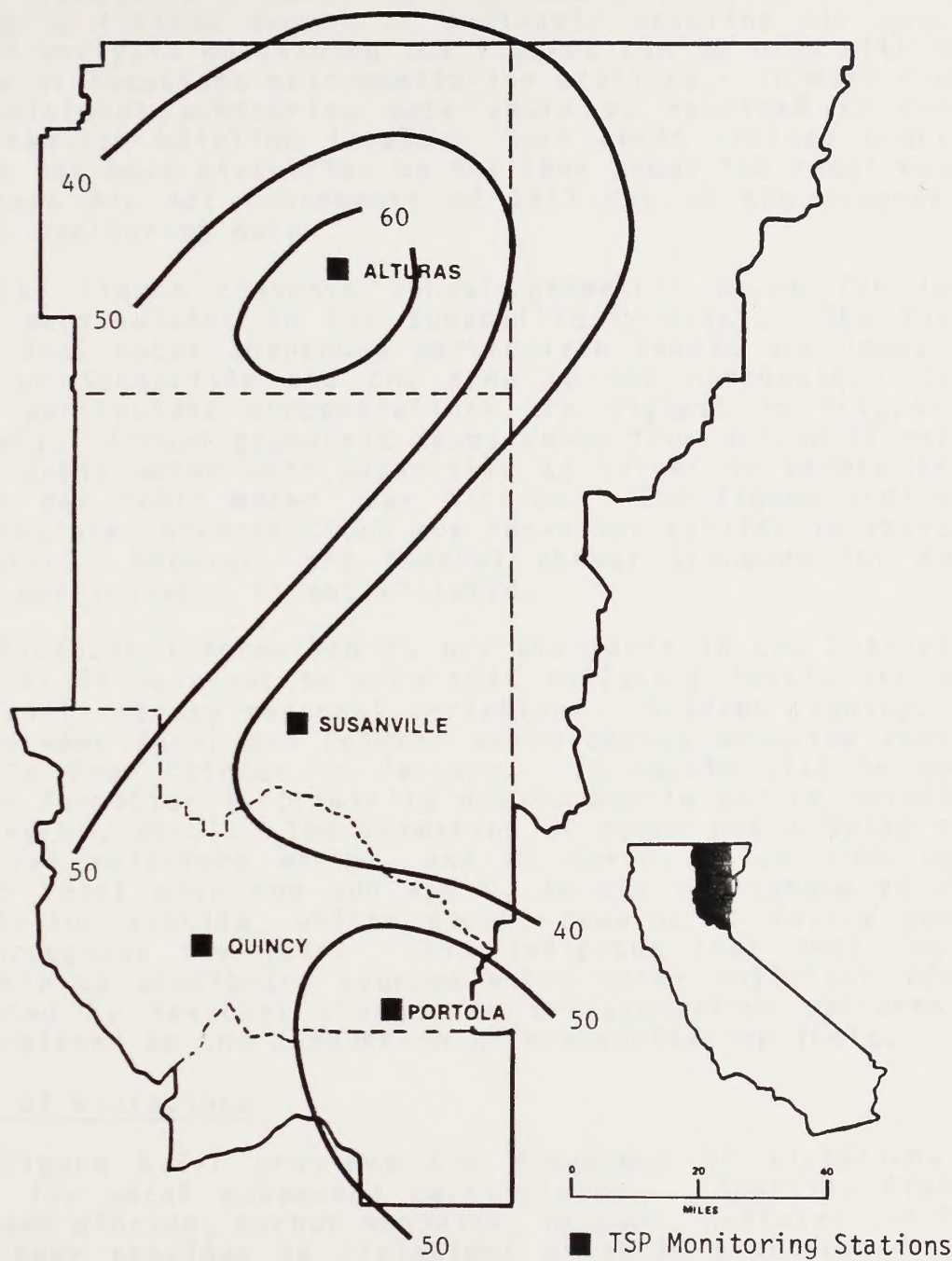

Figure 5.3-6
 Annual Geometric Means ($\mu\text{g}/\text{m}^3$)
 for Total Suspended Particulates in the Susanville District

NATIONAL AMBIENT AIR QUALITY STANDARD FOR TSP = $75 \mu\text{G}/\text{M}^3$ ANNUAL GEOMETRIC MEAN
 CALIFORNIA TSP STANDARD = $60 \text{ G}/\text{M}^3$ ANNUAL GEOMETRIC MEAN.

Source: CARB, 1977

depicted in the figure. The reader is cautioned in the use of this and subsequent figures that contours have been provided based upon a limited amount of available baseline air quality data. The analysis containing the figures can be used with most confidence at locations near monitoring stations. In more remote areas, additional monitoring data would be required to confidently establish baseline levels. Such areas include counties which have not been classified by the CARB under the requirements of the Clean Air Act Amendments of 1977 due to the absence of sufficient monitoring data.

The figure presents annual geometric means for total suspended particulates in the Susanville District. The figure indicates that total suspended particulate levels are lowest in the City of Susanville and the area to the northeast. Total suspended particulate concentrations are highest in Alturas in Modoc County. Annual geometric means range from around 32 micrograms per cubic meter near Susanville to values in excess of 60 micrograms per cubic meter near Alturas. The figure indicates that particulate concentrations are above the California standard near Alturas. However, the federal annual standard for total suspended particulates is not violated.

Although information is not available in the Susanville District, it is relevant to note that pollutant levels are subject to fairly strong seasonal variations. Oxidant readings are highest between April and October while carbon monoxide reaches peak levels from October to January. It should also be noted that ozone formation is primarily due to mobile source emissions (autos, trucks, etc.). The formation of ozone has a delay time from initial emissions of NO_2 and HC during which time these pollutants react with the sun and O_2 in the atmosphere to form ozone. Sulfur dioxide, unlike ozone, remains at fairly steady levels throughout the year. This indicates that most SO_2 is attributable to stationary sources while other pollutant levels are affected by seasonal changes in transportation patterns as they are related to the combustion of transportation fuels.

Frequency of Violations

Figure 5.3-7 provides the frequency of violations of standards for total suspended particulates. Specific figures for nitrogen dioxide, carbon monoxide, oxidant, sulfates and lead have not been provided as violations of these standards in the Susanville District were found to be zero.

Figure 5.3-7 provides the frequency of violations of the California twenty-four-hour standard for total suspended particulates ($100 \mu\text{g}/\text{m}^3$). The figure indicates that the standard has been violated in the northwestern section of the District. The frequency of violations ranges from 0% at Portola, Quincy and Susanville to almost 12% at Alturas. This pattern reflects the one described for baseline total suspended particulate levels as described by the annual geometric mean depicted in Figure 5.3-6.

The high value in this area is largely due to industrial development and associated dust.

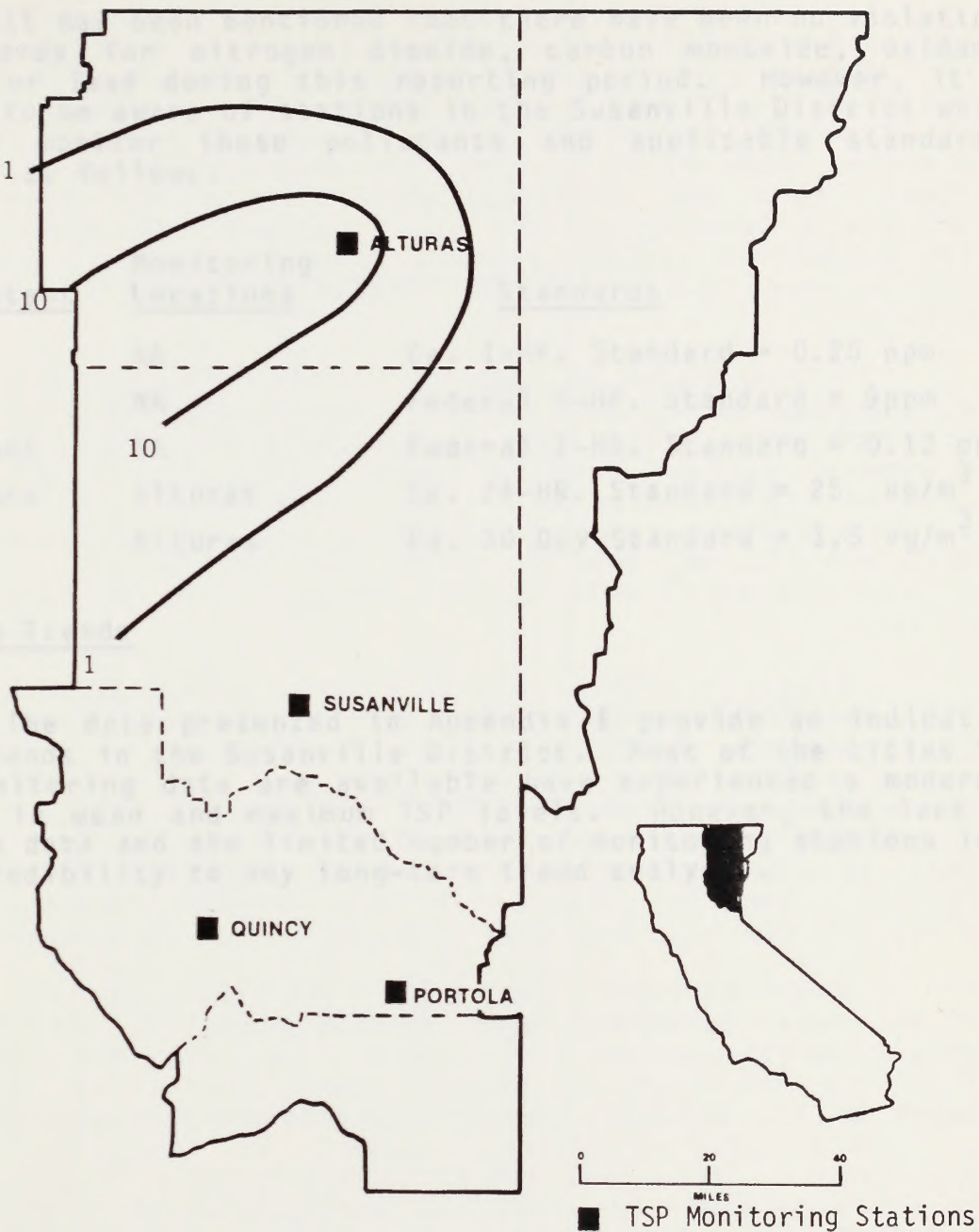

Figure 5.3-7

Frequency (%) of Violations of the California
24-Hour Standard (1) for Total Suspended Particulates

(1) CALIFORNIA 24-HOUR STANDARD FOR TOTAL SUSPENDED PARTICULATES = 100 G/M^3

Source: CARB, 1977

The high value in this area is largely due to industrial development and wind-blown dust.

It has been mentioned that there have been no violations of standards for nitrogen dioxide, carbon monoxide, oxidant, sulfates or lead during this reporting period. However, it is relevant to be aware of stations in the Susanville District which currently monitor these pollutants and applicable standards. These are as follows:

<u>Pollutant</u>	<u>Monitoring Locations</u>	<u>Standards</u>
NO ₂	NA	Ca. 1-HR. Standard = 0.25 ppm
CO	NA	Federal 8-HR. Standard = 9ppm
Oxidant	NA	Federal 1-HR. Standard = 0.12 ppm
Sulfate	Alturas	Ca. 24-HR. Standard = 25 $\mu\text{g}/\text{m}^3$
Lead	Alturas	Ca. 30 Day Standard = 1.5 $\mu\text{g}/\text{m}^3$

Long-Term Trends

The data presented in Appendix E provide an indication of TSP trends in the Susanville District. Most of the cities for which monitoring data are available have experienced a moderate increase in mean and maximum TSP levels. However, the lack of long-term data and the limited number of monitoring stations lend little credibility to any long-term trend analysis.

5.4 POINT AND AREA SOURCES IN THE SUSANVILLE DISTRICT

As will be discussed in Section 6 in more detail, the Susanville District includes four counties, each comprising an Air Pollution Control District (APCD). Counties in the Susanville District by AQCR include Modoc, Lassen, Plumas, Sierra and part of Nevada County in California and also parts of Humboldt and Washoe Counties in Nevada. The area includes a diverse range of agricultural and industrial activities and settlement patterns which are a function of the wide geographical variety. Industrial activities include asphalt, gravel, cement, lumber, forest products, open burning dumps, highway construction, and power stations.

A wide range of sources and their associated stack and flow characteristics are noted in the Susanville District. The electrical power plants tend to have multiple (2-10) stacks which are several hundred feet in height. The stacks are typically 11-20 feet in diameter with flow rates from 10,000 to 875,000 actual cubic feet per minute (ACFM). Primary emissions from such plants are CO, NO_x and SO_x (from fuel combustion). Plants of such size typically emit several thousand tons of each pollutant per year.

Other industrial plants (sugar, refractories, glass and so on) usually have only 2-4 stacks which range from 15 to 200 feet in height. These have typical diameters of 2-10 feet and flow rates from 200 to 70,000 cubic feet per minute, an entire order of magnitude smaller than the typical electrical plant. The pollutants most commonly emitted are HC, TSP and CO. Pollutant amounts are generally several hundred (200-800) tons, annually. Chemical plants can emit several thousand tons per year of TSP and SO_x, but this is larger than the average plant.

Other emitters, more common to the Susanville District, such as lumber companies, open burning dumps and food processing plants generally do not have stacks. Emissions are commonly TSP and CO, in the range of 100-500 tons, annually. (A detailed summary of the District's point sources is provided in Appendix F). Table 5.4-1 provides a summary of typical source exit characteristics for a variety of source types. These data can be used for simplistic or screening level modeling as discussed in more detail in Section 4.9.

Area sources comprise three principal types: solid waste disposal, fuel sources other than factories (such as residences and institutions or transportation) and evaporative losses from solvents and gasses. Major emitters are residential and institutional fuel burning (particularly natural gas), onsite residential incineration, gasoline and diesel fuel used in transportation and depending on the county, solvent evaporative losses. Appendix G provides a complete listing of area source totals on a countywide basis for the Susanville District. Figures 5.4-1

Table 5.4-1
Exit Characteristics For
A Cross-Section of Typical Sources

Source	Primary Pollutant(s)	Emission Type	Typical Upward Exit Velocity	Typical Exit Temp.	Typical Exit Height	Typical Exit Diameter
Fugitive Dust	TSP	Ground-level, non-buoyant	Zero	Ambient	4 to 10m (mechanical lift)	N/A
Automobiles	NO _x , CO, HC	Ground-level, slightly buoyant	Zero	150°C to 200°C	0.5m	0.6 to 1.5m
Oil Recovery Operations (Steam Generators)	SO ₂ , NO _x	Low-level, buoyant	2 to 6 m/s	200°C to 300°C	3 to 7m	1 to 1.5m
Oil Refinery	SO ₂ , NO _x , CO	Intermediate Level buoyant	6 to 8 m/s	200°C to 400°C	20 to 30m	1 to 2m
Power Plant	SO ₂ , NO _x , TSP	Elevated, buoyant	8 to 15 m/s	200°C to 500°C	120 to 180m	4 to 10m

N/A = Not Applicable

through 5.4-5 indicate the density of emissions for each of the primary pollutants in the Susanville District. The counties of the Susanville District with the highest emission totals are Plumas and Lassen.

Figure 5.4-1 indicates that particulate emissions are heaviest in Plumas County where in excess of 3,000 tons per year are emitted by both point and area sources. Other counties with relatively heavy emissions include Lassen and Modoc where emissions range between 1,000 and 2,000 tons per year. As indicated in Appendix F, the largest contributor to the relatively heavy annual totals in Plumas County is Feather River Lumber Company.

Sulfur dioxide emissions are presented in Figure 5.4-2 for the Susanville District. Counties with the heaviest annual emission rates for both point and area sources are Plumas and Lassen Counties where emissions range between 100 and 150 tons per year. The bulk of these emissions are due to area sources, especially transportation.

Figure 5.4-3 provides annual emissions densities for oxides of nitrogen in the Susanville District. Once again, emissions are heaviest in Lassen and Plumas Counties where annual rates are between 1,000 and 2,000 tons. Area sources contribute substantially to NO_x emissions as they generally far outweigh combustion emissions^x due to major point sources, such as Eagle Lake Lumber Company in Susanville.

Annual emissions of carbon monoxide are presented in Figure 5.4-4. Heaviest emissions occur in Plumas County. As with oxides of nitrogen, various sources contribute heavily to carbon monoxide levels. Contributing major point sources include Feather River, Chaney California, Essex, and Plumas Lumber Companies.

Finally, Figure 5.4-5 provides emission densities for hydrocarbons for counties in the Susanville District. Once again, heaviest emissions occur in Plumas County due almost exclusively from area sources. Totals are greater than 5,000 tons per year.

Figures 5.3-1 through 5.3-5 indicate the attainment status of the various counties in the District. It is evident that all areas of the District are subject to Prevention of Significant Deterioration (PSD) regulations (as will be discussed in Section 6) for TSP, SO_2 , NO_2 , CO, HC and oxidant. At this time there are no areas in the Susanville District which have been designated as nonattainment areas. If, however, this status would be designated to some county in the future, that area would then be subject to nonattainment rules for that pollutant.

Since all BLM lands in the Susanville District are subject to PSD regulations, depending upon BLM projected usages

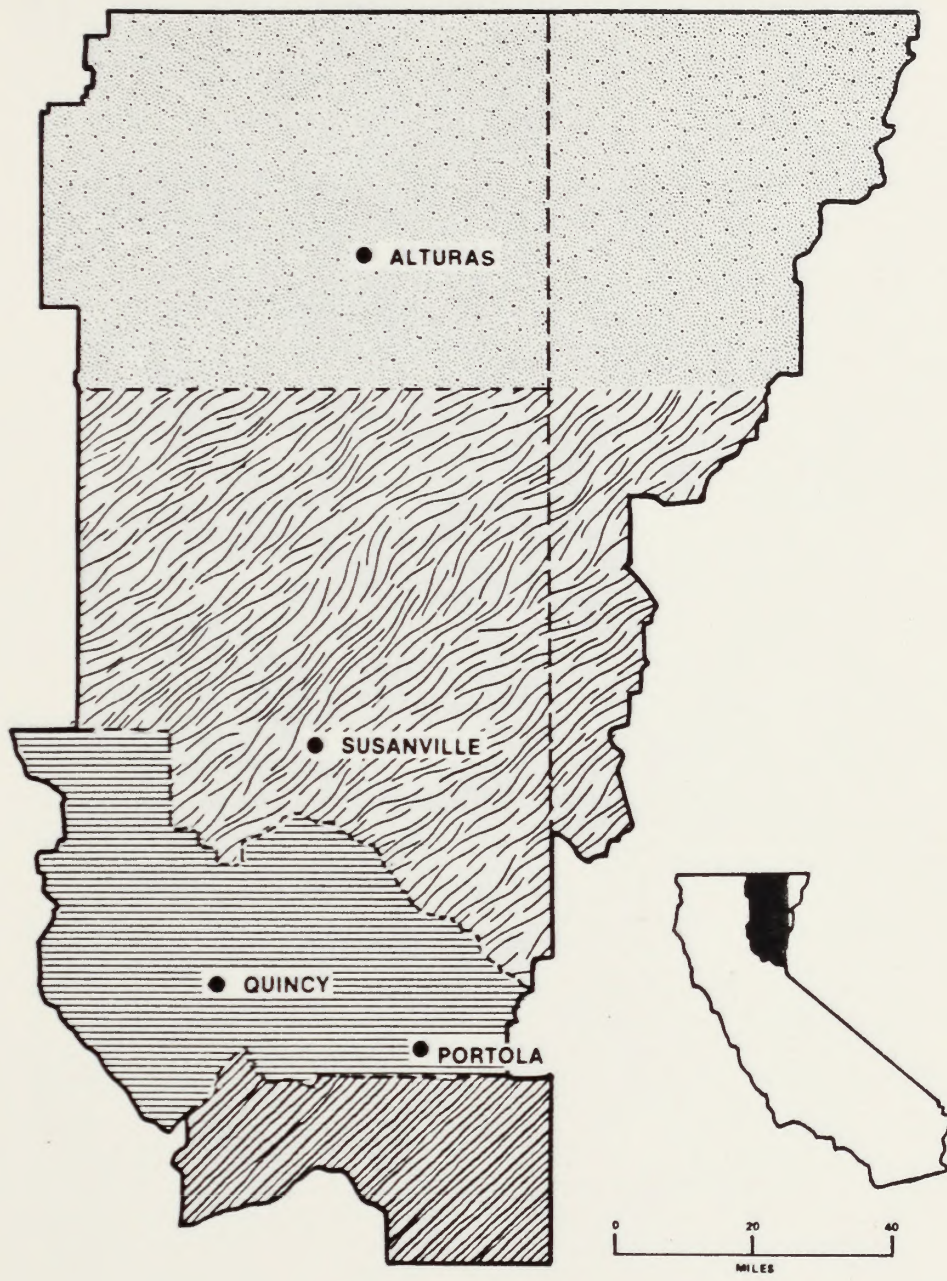





-  0 - 500
-  500 - 1500
-  1500 - 3000
-  3000 - 4000

Figure 5.4-1
 Total Emissions of TSP
 (Tons/Year)
 in the Susanville District

Source: NEDS, 1975

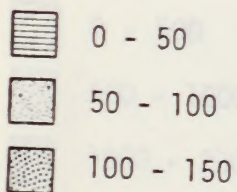
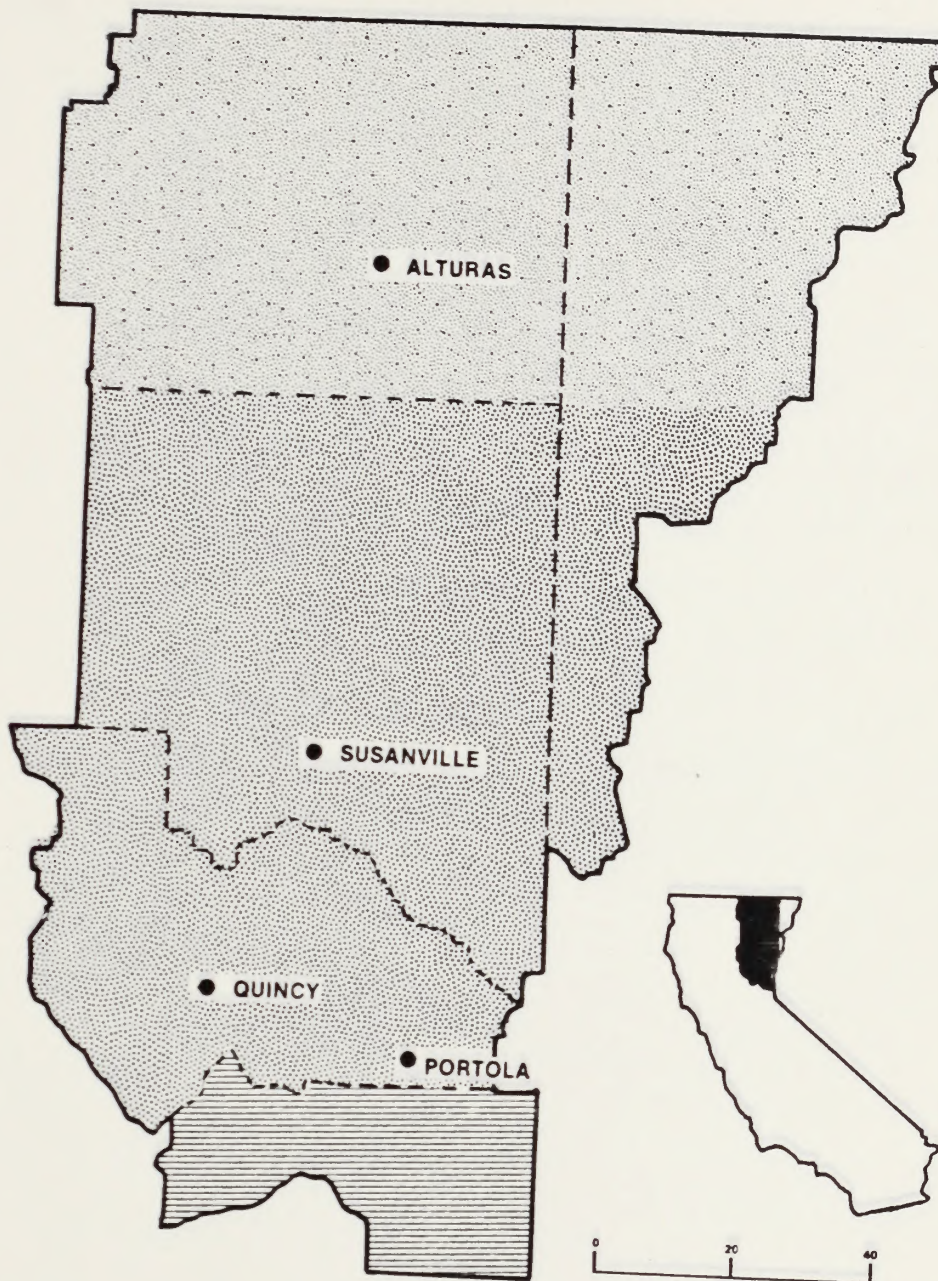
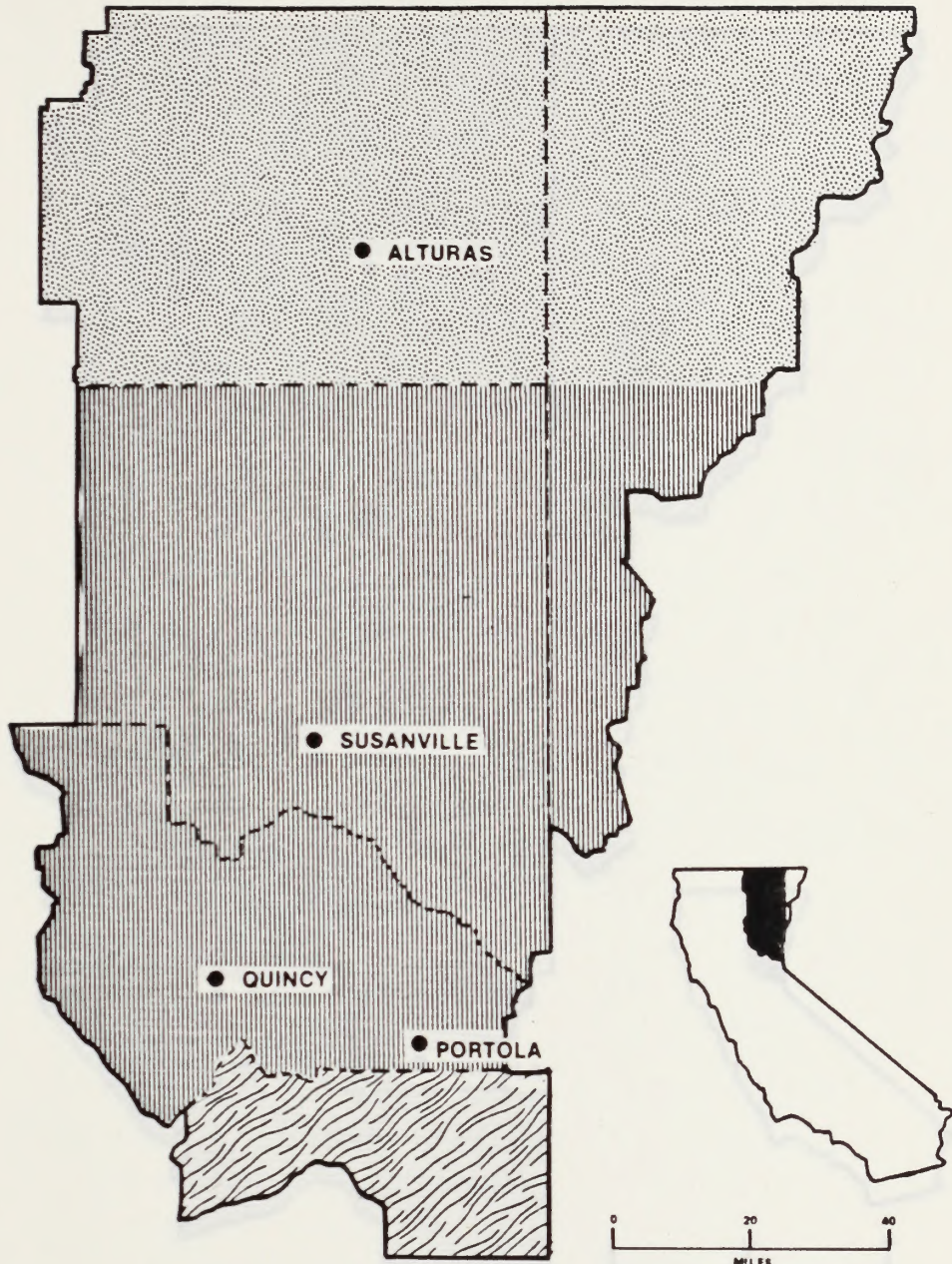

Figure 5.4-2
 Total Emissions of Sulfur Dioxide
 (Tons/Year)
 in the Susanville District

Source: NEDS, 1975





-  0 - 500
-  500 - 1000
-  1000 - 2000

Figure 5.4-3
 Total Emissions of Oxides of Nitrogen
 (Tons/Year)
 in the Susanville District

Source: NEDS, 1975

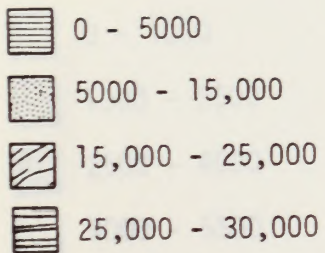
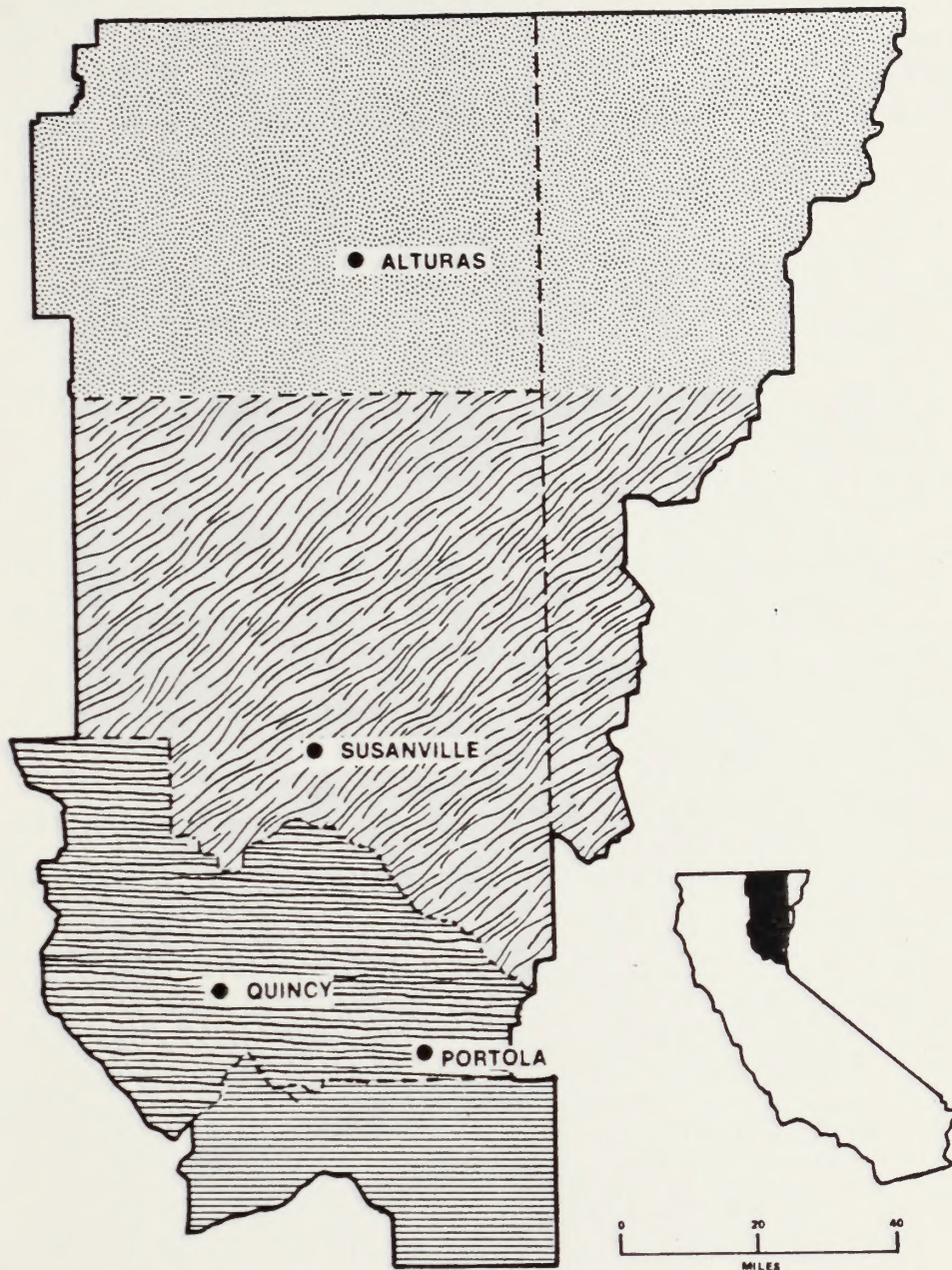
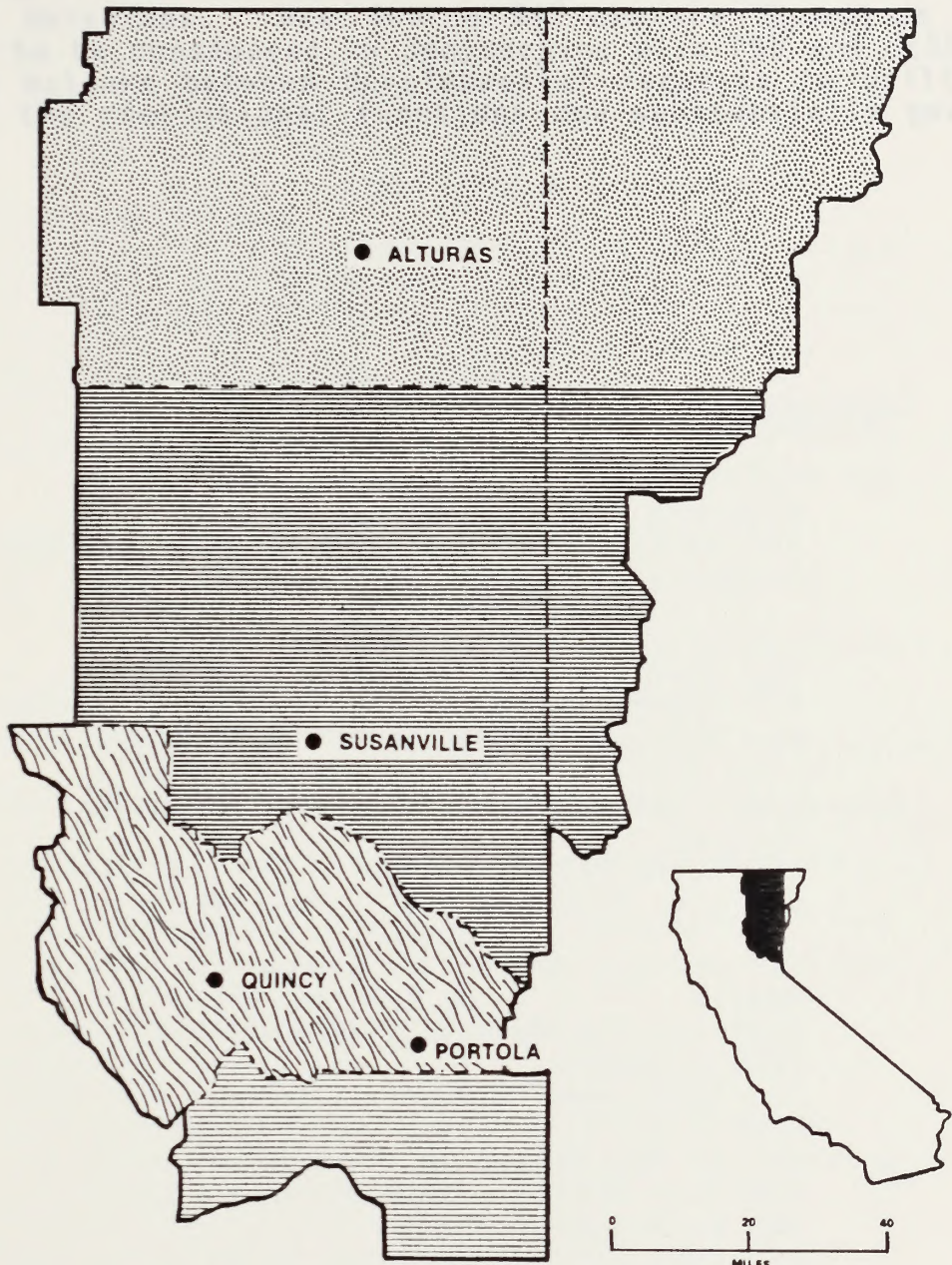

Figure 5.4-4
 Total Emissions of Carbon Monoxide
 (Tons/Year)
 in the Susanville District

Source: NEDS, 1975



-  0 - 1000
-  1000 - 2500
-  2500 - 4000
-  4000 - 5500

Figure 5.4-5
 Total Emissions of Hydrocarbons
 (Tons/Year)
 in the Susanville District

Source: NEDS, 1975

of these lands, the PSD increments will limit the amount of new construction possible in these areas, the type and size of proposed facilities and abatement equipment to be used to control projected emissions. New Source Performance Standards (NSPS) will have to be considered in conjunction with PSD and NESHAPS to provide a balance between developmental requests to utilize BLM lands and the recreational functions now substantially governing land use.

5.5 ASSISTANCE IN AIR POLLUTION PROBLEMS

REFERENCES

Abstracts

Air Pollution Control Association Abstracts
Air Pollution Control Association
4400 Fifth Avenue,
Pittsburgh, Pennsylvania

Public Health Engineering Abstracts
Superintendent of Documents
U.S. Government Printing Office
Washington, D.C.

Periodicals

Air Engineering
Business News Publishing Company
450 W. Fort Street
Detroit, Michigan

American City
The American City Magazine Corporation
470 Fourth Avenue,
New York, New York

American Industrial Hygiene Association
Journal
14125 Prevost
Detroit, Michigan

American Journal of Public Health and Nations'
Health
American Public Health Association, Inc.
1790 Broadway
New York, New York

Archives of Environmental Health
American Medical Association
535 N. Dearborn Street
Chicago, Illinois

Atmospheric Environment
Pergamon Press
122 East 55th Street
New York, New York

Atmospheric Pollution Bulletin
Warren Spring Laboratory
Gunnels Wood Road
Stevenage, England

- Chemical Engineering
McGraw-Hill Publishing Company, Inc.
330 W. 42nd Street
New York, New York
- Chemical Engineering Progress
American Institute of Chemical Engineers
345 47th Street
New York, New York
- Chemical Reviews
American Chemical Society
20th and Northampton Streets
Easton, Pennsylvania
- Environmental Health Series
National Centre for Air Pollution Control
4676 Columbia Parkway
Cincinnati, Ohio 45226
- Heating, Piping and Air Conditioning
Keeney Publishing Company
6 North Michigan Avenue
Chicago, Illinois
- Industrial and Engineering Chemistry
American Chemical Society
1155 Sixteenth Street, N.W.
Washington, D.C.
- Industrial Hygiene Foundation of America,
Transactions Bulletin
Industrial Hygiene Foundation of
America, Inc.
4400 Fifth Avenue
Pittsburgh, Pennsylvania
- Industrial Medicine and Surgery
Industrial Medicine Publishing Company
P.O. Box 306
Miami, Florida 33144
- Industrial Water and Wastes
Scranton Publishing Company, Inc.
35 E. Wacker Drive
Chicago, Illinois
- Journal of the Air Pollution Control
Association
Air Pollution Control Association
4400 Fifth Avenue
Pittsburgh, Pennsylvania

Journal of Colloid Science
Academic Press, Inc.
111 Fifth Avenue
New York, New York

Mechanical Engineering
American Society of Mechanical Engineers
345 E. 47th Street
New York, New York

The Oil and Gas Journal
211 South Cheyenne Avenue
Tulsa, Oklahoma

Public Health Reports
U.S. Department of Health, Education and
Welfare
Public Health Service, Superintendent of
Documents
U.S. Government Printing Office
Washington, D.C. 20402

Public Works
Public Works Journal Corporation
200 South Broad Street
Ridgewood, New Jersey

Smokeless Air
National Society for Clean Air
Field House, Breams Building
London E.C., England

Transaction of the American Society of
Mechanical Engineers
Journal of Engineering for Power (Series
A of the Transactions of the ASME)
Journal of Engineering for Industry
(Series B)
Journal of Heat Transfer (Series C)
Journal of Basic Engineering (Series D)
Journal of Applied Mechanics (Series E)
American Society of Mechanical Engineers
345 East 47th Street
New York 17, New York

Transactions of Institution of Chemical
Engineers
Institution of Chemical Engineers
16 Belgrave Square
London S.W., England

Environmental Science and Technology
American Chemical Society
1155 Sixteenth Street N.W.
Washington, D.C. 20036

Books

Encyclopedia of Instrumentation for Industrial Hygiene, University of Michigan, Ann Arbor, 1956.

Frenkiel, F.N.; and Sheppard, P.A. Editors, Atmospheric Diffusion and Air Pollution, Academic Press, London, 1959.

Publications

Air Pollution Abatement Manual Manufacturing Chemists' Association, Inc.
1625 Eye Street, N.W. Washington, D.C.

The Air Pollution Bibliography
The Library of Congress Technical Information Division Washington, D.C.

Air Pollution Control Association Abstracts,
Air Pollution Control Association
4400 Fifth Avenue
Pittsburgh, Pennsylvania

Applied Science and Tehcnology Index
The H.W. Wilson Company
950 University Avenue
New York, New York

Battelle Technical Review
Battelle Memorial Institute
505 King Avenue
Columbus, Ohio

Chemical Abstracts
American Chemical Society
1155 Sixteenth Street, N.W.
Washington, D.C.

Engineering Index
Engineering Index, Inc.
345 East 47th Street
New York, New York

Environmental Effects on Materials and Equipment
Prevention of Deterioration Center
National Academy of Sciences
National Research Council
2101 Constitution Avenue, N.W.
Washington, D.C.

Meteorological and Geostrophysical Abstracts
American Meteorological Society
45 Beacon Street
Boston, Massachusetts

Monthly Catalog of United States
Government Publications
Superintendent of Documents
U.S. Government Printing Office
Washington, D.C.

Public Health Engineering Abstracts
Superintendent of Documents
U.S. Government Printing Office
Washington, D.C.

Quarterly Cumulative Index Medicus
American Medical Association
535 N. Dearborn Street
Chicago, Illinois

Readers' Guide to Periodical Literature
The H.W. Wilson Company
950 University Avenue
New York, New York

Clearinghouse Announcements in Science and
Technology
Category 68. Environmental Pollution and
Control.
CFSTI U.S. Dept. Commerce
Springfield, Va. 22151

Bibliographies

Air Pollution Publications - A Selected
Bibliography 1955 - 1963. Public Health
Service Publication No. 979.

Air Pollution Publications - A Selected
Bibliography 1963-1966. Public Health
Service Publication No. 979

Environmental Health Series Reports -
References and Abstracts. Public Health
Service, National Center for Air
Pollution Control, 1966.

Reference List of Publications. Section 1 Air
Pollution, Public Health Service,
National Center for Air Pollution
Control. 1964

Carbon Monoxide - A Bibliography with Abstracts. U.S. Dept. HEW, Public Health Service. Publication No. 1503. 1966.

Sulfur Oxides and other Compounds - A Bibliography with Abstracts, U.S. Dept. HEW Public Health Service, Publication No. 1093. 1965

Nitrogen Oxides: An Annotated Bibliography
NAPCA Pub. No. AP-72, August 1970.

Hydrocarbons and Air Pollution: An Annotated Bibliography. NAPCA PUB. No. AP-75 (Parts I, II), October 1970.

Photochemical Oxidants and Air Pollution: An Annotated Bibliography. Pub. No AP-88 (Parts 1, 2), March 1971.

World Meteorological Organization-List of Available Publications
WMO Publications Center
UNIPUB Inc.
P.O. Box 433
New York, N.Y. 10016

Professional Meteorological Consultants

Professional meteorologists advertise their services in the Professional Directory section of the Bulletin of the American Meteorological Society. In the May 1979 Bulletin, 83 such firms and individuals were listed. The American Meteorological Society has in the last several years instituted a program of certifying consulting meteorologists. Of the 83 professional services listings in the Bulletin, 40 list Certified Consulting Meteorologists.

Local U.S. National Weather Service Office

The Air Stagnation Advisories are received here by teletype from the National Meteorological Center. Often the public telephones the Weather Service with air pollution complaints which the meteorologists may have traced back to a specific source by examining local wind circulations. Through personal contact with the meteorologist-in-charge (MIC) specific, localized forecasts may be arranged to support a short-term air pollution investigation or sampling program.

USEPA

The USEPA provides a complete information service to all individuals, groups, companies, etc. This includes information on regulations, publications as well as expert advice.

Contract Work

Many universities do contract work for private organizations and for government agencies on meteorological problems and also on air pollution surveys.

5.6 GLOSSARY OF TERMS

Acetylenes	A group of unsaturated hydrocarbons whose carbon atoms possess a triple bond.
Acid	A compound that turns blue litmus paper red, generally tastes sour and most often is corrosive; in solution it produces hydrogen ions or protons which can be replaced by metal to form a salt. Acids usually contain hydrogen, neutralized alkalis and form well defined salts.
Adhesion	The force of attraction between unlike molecules, causing adjoining or attachment.
Aerosol	A system of colloidal particles dispersed in a gas.
Affinity	A natural liking or reaction; the phylogenetic relationship between two organisms or groups of organisms resulting in a resemblance in general plan or structure; the force by which atoms are held together in chemical compounds.
Alcohol	C_2H_6O or C_2H_5OH , a volatile, colorless pungent liquid; often used as a generic term which includes ethyl alcohol, methol alcohol, amyl alcohol and glycerin.
Aldehyde	Dehydrogenated alcohol.
Alert Levels	A concentration of pollution which dictates the issuance or notification by State Regulatory Agencies to the general public that a threat to human health may occur due to elevated pollution levels.
Algae	Simple aquatic plants without leaves, stems or roots sometimes having brown or reddish pigments.
Alkanes	The group of hydrocarbons in the methane series, also called saturated hydrocarbons or parafins (C-H).
Alkenes	A group of hydrocarbons with one double bond; also called olefins or unsaturated hydrocarbons (C=C).
Amides	Organic compounds that contain the CO NH_2 radical or an acid radical in replacement for one hydrogen atom of an ammonia molecule.

Amines	Ammonia bases, that is, chemical substances resulting from replacing ammonia hydrogen atoms with alkyl groups $[(CH_3)_x-N-Hy]$; amines are products of animal or vegetable decomposition.
Amino Acids	Fundamental structural units of proteins; they are fatty acids in which one hydrogen atom has been replaced by an amino group.
Amphibole	Any of the complex group of the hydrous silicate materials containing chiefly calcium, magnesium, sodium, iron and aluminum, and including hornblend, asbestos, etc.
Anaerobic	Living in the absence of air or free oxygen.
Anoxia	Without oxygen, lack of oxygen for body use.
Aortic	The conveyance of blood from the left ventricle of the heart to all of the body except the lungs.
Aqueous	Water acting as a solvent in a solution; a fluid resembling water.
Aromatics	Any unsaturated hydrocarbon with cyclic molecules resembling benzene, C_6H_6 , in chemical behavior, so named because of the fragrant odor of many in the class.
Arteriosclerosis	An arterial disease characterized by an inelasticity and thickening of the vessel walls, with lessened blood flow.
Asbestos	A fibrous amphibole used for making fire-proof articles.
Asphyxiant	An agent or substance which causes death or loss of consciousness by the impairment of normal breathing.
Biosphere	That portion of the world and its atmosphere in which humans, animals and plants can survive.
Broncho-constrictor	An agent that causes the contraction of the muscles which control the pharynx.
Carcinogenic	Refers to a substance that is known to induce cancer.

Catalase	The enzyme responsible for the decomposition and oxidation of hydrogen peroxide into water and oxygen.
Catalyst	A substance which accelerates or promotes a chemical action by a reagent which itself remains unchanged.
Catalytic Convertor	A device attached to an automobiles internal combustion engine which chemically alters emissions from the engine prior to release through the exhaust system. The catalytic convertor was introduced on modern-day automobiles in the mid-1970's in an effort to reduce harmful automobile exhaust emissions and promote a cleaner environment.
Cation	Ions of positive charge deposited on the cathode.
Cellulose	The complex carbohydrate substance that forms the material of cell walls of plants.
Chlorotic Mottle	Brown or red spots on the surface of a leaf caused by chemical pollution.
Chlorosis	A diseased condition in green plants marked by yellowing or blanching.
Cholestrol	A sterol, $C_{27}H_{45}OH$, occurring in all animal fat and oils, bile, gall stones, nerve tissue, blood, etc.
Chrysotile	A fibrous variety of serpentine; asbestos.
Colloid	A substnace in a state of matter characterized by having small power of diffusion.
Cyprinid	Any fish belonging to the minnow family; carplike in form or structure.
Diastase	The enzyme responsible for starch utilization.
Deformation	The act of marring the natural form or shape of an object; distortion.
Discoloration	The act or fact of changing or spoiling the color of an object; a fade or a stain.
Dissociation	The breaking up of a compound into its simpler constituents by means of heat or electricity.

Ecosystem	A habitable environment existing naturally or created artificially.
Edema	Effusion of serous fluid into the interstices of cells, in tissue spaces or into body cavities.
Emission Density	Emissions per unit area.
Endogenous	Originating or developing internally or within.
Endothermic	Noting or pertaining to a chemical change that is accompanied by an absorption of heat.
Enzyme	A protein substance secreted in animals or by plants whose function is catalytic, promoting chemical reactions for metabolic or physiological processes.
Ester	A compound produced by the reaction between an acid and an alcohol with the elimination of a molecule of water.
Ether	A series of compounds formed by dehydration of alcohols.
Fauna	Collective animal life of any particular geographical area or time.
Fixation	The act of making stable in consistence or condition; reduction from fluidity or volatility to a more permanent state.
Flora	Collected plant life of any particular area or time.
Flourescence	Emitting radiation (such as light) as a result of, and only during the time of, exposure to radiation from another source.
Glucosidase	The enzyme that catalyzes glucose.
Greenhouse Effect	Most of the infrared radiation emitted by the earth is absorbed by carbon dioxide and water in the atmosphere. Part of the infrared radiation absorbed is re-radiated back to earth. This trapping and recycling of terrestrial radiation, which makes the earth warmer than it would be otherwise, is known as Greenhouse Effect, because it was once thought that greenhouses remain warm by the same process.

Heavy Metal	A metal which is made up of elements having large atomic weights.
Hematocrit	A centrifuge for separating the cells of the blood from the plasma.
Hemoglobin	The protein coloring matter of the red blood corpuscles, serving to convey oxygen to the tissues and occurring in reduced form in venous blood and in combination with oxygen in arterial blood.
Herbivorous	Feeding on plants.
Homolog	An object corresponding in structure and in origin, but not necessarily in function, to another object; chemicals of the same type, but which differ by a fixed increment in certain constituents.
Humus	The dark organic material in soil produced by the decomposition of vegetable or animal matter.
Hydrate	Compounds with large amounts of water as part of their molecular structure and without rearrangement of the atoms of the H ₂ O group; hydration is the chemical union of water and any substance.
Hydrolyze	To subject or be subjected to decomposition in which a compound is split into other compounds by taking up the elements of water.
Hypertrophy	An abnormal enlargement of a part or organ.
Hyphai	One of the thread-like elements of the vegetative part of fungi.
Inertial	Matter having the property by which it retains its state of rest or its velocity along a straight line so long as it is not acted upon by an external force.
Insectivorous	Adapted to feeding on insects.
Intercostal Leaf Area	Leaf area between the ribs.
Irradiation	The act of having been heated with radiant energy; the act of having been exposed to radiation.

Irritant	A biological, chemical or physical agent that stimulates a characteristic function or elicits a response, especially an inflammatory response.
Ketones	A group of organic compounds characterized by a carbonyl radical (C=O) united with two hydrocarbon radicals; usually colorless, pungent substances.
Leach	A process by which a liquid filters through another substance.
Lichen	A plant composed of an algae and fungi growing together.
Macrophage	A large cell that characteristically engulfs a foreign material and consumes debris and foreign bodies.
Marginal Leaf Area	Leaf edges.
Mercaptan	Compound analogous to alcohol containing sulfur in place of oxygen (R-S-H).
Metabolism	The chemical activity that takes place in the cells of living organisms involving two fundamental procedures, catabolism and anabolism, simultaneously at work; the former refers to the breaking up of substances into constituent parts, the latter, building up of the substances from simpler ones.
Microdecomposer	Bacteria which breakdown waste material in soil and in water as a prelude to the initiation of a nutrient recycling process.
Necrosis	Death or decay of tissue.
Nitriles	Any of a class of organic compounds with the general formula $RC \equiv N$.
Nucleation	Any process by which a phase change (condensation, sublimation, freezing) is initiated at certain loci (points).
Olefins	Members of a hydrocarbon group characterized by the formula $C_n H_{2n}$ and including ethylene, propylene and ⁿ butylene; they are highly reactive and can be formed by destructive distillation of coal petroleum.
Organic Acids	Acids which are usually derived from natural or living sources.

Oxidizer	A substance which causes the conversion of an element into its oxide (which is accompanied by an increase in oxidation number as opposed to a reducing agent which promotes a decrease in oxidation number); a substance which promotes the covering of an element with a coating of oxide or rust.
Pathological	Caused by or involving disease.
Peroxidase	A type or class of oxidoreductase enzymes that causes the oxidation of a compound by the decomposition of hydrogen peroxide or an organic peroxide.
Peroxides	A class of compounds containing oxygen and other elements, with the O_2 group having a valence of two (-) and acting like a radical.
Phenol	A white crystalline solid obtained from the distillation of tar; it is poisonous and corrosive with a characteristically pungent odor.
Photochemical	Refers to the effects of radiation, visible or ultraviolet, upon chemical reactions.
Photon	A quantum of energy; a fundamental bundle of radiation whose energy is directly proportional to the frequency of the radiation.
Photoplankton	The aggregate of passively floating or drifting organisms in a body of water which derive most of their energy from light.
Photosynthesis	The process by which green plants, containing chlorophyll, with the aid of energy from the sun, manufacture carbohydrates from water and carbon dioxide.
Phototoxicant	A substance that is poisonous to plants.
Podsal	An infertile, acidic forest soil having an ash-colored upper layer depleted of colloids and of iron and aluminum compounds, and a brownish lower layer in which these colloids and compounds have accumulated.
Precursor	A person or object that goes before and indicates the approach or something else.
Primary Pollutant	A pollutant in the form that it is released from its source is considered a primary pol-

	lutant as opposed to a secondary pollutant which has undergone chemical change after being emitted to the atmosphere.
Progenitor	An original or model for later developments; predecessor; precursor.
Pulmonary	Of or pertaining to the lungs.
Pulmonary Fibrosis	A condition marked by an increase of interstitial fibrous tissue in the lungs.
Radical	A combination of atoms that stay together and take part in the chemical reaction as a unit or a group as if it were a single element.
Reactant	Any substance that undergoes a chemical change in a given reaction.
Reactivity	Pertaining to or characterized by reaction.
Secondary Pollutant	A pollutant is considered a secondary pollutant if a chemical change has occurred subsequent to its release from its source.
Serpentine	A common mineral, hydrous magnesium silicate, usually oily green and sometimes spotted, occurring in many varieties, used for architectural and decorative purposes.
Serum Lactate Dehydrogenase	A class of oxide reductase enzymes that catalyze the removal of hydrogen from the esters or salts of lactic acid.
Sink	A lower state or condition.
Sorption	The binding of one substance by another by any mechanism, such as absorption, adsorption or persorption.
Source	A place from which something comes, arises or is obtained.
Spectroscopy	A procedure for observing the spectrum of light or radiation from any source. Spectroscopy permits the examination and measurement of the spectrum of radiant energy.
Stark-Einstein Law	A law of chemistry which states that one proton must be absorbed by a substance to initiate chemical decomposition.

Stoichiometry	Branch of chemistry dealing with weights and proportions of elements in chemical combination and the methods of determining them.
Stunting	Stopping or slowing down of the growth or development of an object.
Sulfate	Chemical compounds (such as SO_3) created by the photochemical reaction of sulfur dioxide. Sulfates are secondary pollutants with important health and visibility effects.
Sulfide	A binary compound of sulfur with the valence of two (-); also a salt of hydrosulfuric acid.
Synergism	The principal that a cooperative action between two agents - chemical and mechanical for instance - results in an effect greater than the sum of the two effects taken independently.
Terpene	A series of hydrocarbons of the general formula $C_{10}H_{16}$ found in resins.
Thermodynamics	Deals with the principals of conversion of heat into other forms of energy and vice versa.
Toxicity	The quality, relative degree or specific degree of being toxic or poisonous.
Unclassifiable	With respect to air quality, unclassifiable refers to those areas of the country which cannot be a designated attainment or non-attainment area due to insufficient baseline air quality information.
Volatile	Easily vaporized; tending to evaporate at ordinary temperatures and pressure conditions.

BIBLIOGRAPHY

- Adams, E.S. "Effects of Lead and Hydrocarbons from Snowmobile Exhaust on Brook Trout", Transactions of American Fisheries Society, 104(2) April, 1975, pp. 363-373.
- Altshuller, A.P., W.A. Lonneman, and S.L. Kopczynski, J. Air Pollut. Contr. Ass. 23, 597 (1973).
- Altshuller, A.P., Tellus 10, 479 (1958).
- Badsha, K.S. and M. Sainsbury, "Uptake of Zinc, Lead and Cadmium by Young Whiting in the Severn Estuary", Marine Pollution Bulletin 8(7), July 1977, pp. 164-166.
- Bates, D.R., and P.B. Hays, Planet. Space Sci. 15, 189 (1967).
- Benson, F.B., Henderson, and D.E. Caldwell, "Indoor-Outdoor Air Pollution Relationships: A Literature Review," United States Environmental Protection Agency No. AP-112. Research Triangle Park, North Carolina, 1972.
- Bigg, E.K., A. Ono, and W.J. Thompson, Tellus 22, 550 (1970)
- Blosser, R.O., Tappi 55, 8 (1972).
- Boyd, B.D. "The Statistical Picture Regarding Discharges of Petroleum Hydrocarbons in and around United States Waters", American Institute of Biological Sciences, 1976, pp. 37-53.
- Bufalini, J.J., B.W. Gay, Jr., and K.L. Brubaker, Environ. Sci. Technol. 6, 816 (1972).
- Bureau of National Affairs, 1977 Clean Air Act Amendment, Sec. 101, 4b, 1977 p. 3.
- Cadle, R.D., and E.R. Allen, Science 167, 243 (1970).
- Caldwell, R.L., et al. "A Screening Study to Determine the Symptomology and Relative Susceptibility of Selected Native Trees and Shrubs to Sulfur Dioxide", Final Report, University of Arizona.
- California Air Resources Board, Summary of 1977 California Air Quality Data.
- California Air Resources Board, "Ten Year Summary of California Air Quality Data, 1963-1972", January, 1974.
- California Air Resources Board, "Three Year Summary of California Air Quality, 1973-1975", Technical Services Division, January 1977.

- California Air Resources Board, "Recommended Area Designations" a Report to the EPA, Region IX as per Section 107(d)(1) of the Clean Air Act, December 1977.
- Callendar, G.S., *Tellus* 10, 243 (1958).
- Carlson, R.J., and N.C. Ahlquist, *Atmos. Environ.* 3, 653 (1969).
- Cavender, J.H., Kircher, D.S., and Hoffman, A.J., "Nationwide Air Pollution Trends," United States Environmental Protection Agency No. AP-115. Research Triangle Park, North Carolina, 1973.
- Chang, T.Y., and Weinstock, B. J. *Air Pollut. Contr. Ass.* 23 691 (1973).
- Cheswick, J. *Chem. Educ.* 49, 755 (1972).
- Cholak, J., L.J. Schafer, and R.F. Hoffer, *Arch. Ind. Hyg. Occup. Med.* 6, 314 (1952).
- Cholak, J., L.J., Schafer, W.J. Younker, and D.W. Yeager, *Amer. Ind. Hyg. Ass., J.* 19, 371 (1958).
- Coffin, D.L. and J.H. Knelson. "Effects of SO₂ and Sulfate Aerosol Particles on Human Health", *AMBIO*, 1976, pp. 239-242.
- Cortese, A.D. and Spengler, John D. "Ability of Fixed Monitoring Stations to Represent Personal Carbon Monoxide Exposure", *Air Pollution Control Association*, 26(12), December 1976, pp. 1144-1150.
- Cotton, F.A. and G. Wilkinson, "Advanced Inorganic Chemistry," 2nd ed., pp. 323-357. Wiley (Interscience), New York, New York, 1966.
- Craig, H., and L.I. Gordon, *Geochim. Cosmochim. Acta* 27, 949 (1963).
- Cramer, J., *Atmos. Environ.* 7, 241 (1973).
- Derwent, R.G. and H.N.M. Stewart, *Nature (London)* 241, 342 (1973).
- Dvorak, A.J., et al, *Impacts of Coal-Fired Power Plants on Fish, Wildlife, and Their Habitats*, U.S. Dept. of Interior, 1978.
- Eyden, B.P. et al. "Long-term Effects of Dietary Lead Acetate on Survival, Body Weight and Seminal Cytology in Miée", *Bulletin of Environmental Contamination and Toxicology* 19(3), 1978, pp. 266-272.

- Faith, W.L. and A.A. Atkisson, Jr., "Air Pollution," 2nd ed., pp. 163-205. Wiley (Interscience), New York, New York, 1972.
- Faith, W.L., D.B. Keyes, and R.L. Clark, "Industrial Chemicals," 3rd ed., p. 741. Wiley, New York, New York, 1965.
- Finelli, V.N. et al. "Biological Effects of Carbon Monoxide vs. Whole Emissions from Engine with Catalyst", Air Pollution Control Association, 26(3) March 1976, pp. 231-233.
- Gay, B.W., and J.J. Bufalini, Environ. Sci. Technol. 5, 422 (1971).
- Gordon, R.J., M. Mayrsohn, and R.M. Ingels, Environ. Sci. Technol. 2, 1117 (1968).
- Hall, Jr., T.C. and F.E. Blacet, J. Chem. Phys. 20, 1745 (1952).
- Hanst, P.L., J. Air Pollut. Contr. Ass. 21, 269 (1971).
- Hendrey, G.R., et al. "Acid Precipitation: Some Hydrobiological Changes". AMBIO, 1976, pp. 224-227.
- Hill, A.C., et al. "Sensitivity of Native Desert Vegetation To SO₂ and to SO₂ and NO₂ Combined", Air Pollution Association Journal, Vol. 24, No. 2, February 1974, pp. 153-157.
- Hodson, P.V., et al. "pH - Induced Changes in Blood Lead of Lead-Exposed Rainbow Trout", Journal of the Fisheries Research Board of Canada, 35(4), April, 1978, pp. 437-445.
- Institute For Defense Analyses, "Effect of Stratospheric Ozone Depletion on the Solar Ultraviolet Radiation Incident on the Surface of the Earth." Sci. Tech. Div., Washington, D.C., 1973.
- Intersociety Committee, "Methods of Air Sampling and Analysis," pp. 329-336. Amer. Pub. Health Ass., Washington, D.C., 1972.
- Johnstone, H.F., and D.R., Coughanowr, Ind. Eng. Chem. 50, 1169 (1958) 52, 861 (1960).
- Junge, C.E. and J.E. Manson, J. Geophys. Res. 66, 2163 (1961).
- Katz, M., Air Repair 4, 176 (1955).
- Kavet, R.I. and J.D. Brown. "Reaction of the Lung to Air Pollution Exposure", Life Sciences, 15: 849-861.
- Keller, P. "The Lead Poisoning of Agriculturally Useful Areas in Switzerland as a Result of Lead Additives to Gasoline", Schweizerische Landwirtschaftliche Monatshefte (55), 1977, pp. 253-260.

- Larsen, R.I., "A Mathematical Model for Relating Air Quality Measurements to Air Quality Standards," U.S. Environmental Protection Agency No. AP-89, Research Triangle Park, North Carolina, 1971.
- Larsen, R.I., J. Air Pollut. Contr. Ass. 19, 24 (1969).
- Leighton, P.A., "Photochemistry of Air Pollution." Academic Press, New York, New York, 1961.
- Little, A.D., Inc., "Research on Chemical Odors, Part I: Odor Thresholds for 53 Commercial Chemicals." Mfg. Chem. Ass., Washington, D.C., 1968.
- Los Angeles County Air Pollution Control District, "Laboratory Data," Los Angeles, California, 1970-1972.
- Louw, R., J. van Ham, and H. Nieboer, J. Air Pollut. Contr. Ass. 23, 716 (1973).
- Malmer, N. "Acid Precipitation: Chemical Changes in the Soil", AMBIO, 1976, pp. 231-234.
- Manabe, S. and R.T. Wetherald, J. Atmos. Sci. 24, 241 (1967).
- Mason, B., "Principles of Geochemistry," 3rd ed., pp. 208-223. Wiley, New York, New York, 1966.
- Maugh, T.H., II, Science 177, 338 (1972).
- McCormick, R.A. and J.H. Ludwig, Science 156, 1358 (1967).
- Millecan, A.A. "A Survey and Assessment of Air Pollution Damage to California Vegetation in 1970", California Department of Agriculture, June, 1971.
- Millecan, A.A. "A Survey of Air Pollution Damage to California Vegetation, 1970 through 1974", California Department of Agriculture, April, 1976.
- Mordelet-Dambrine, M. "Comparison of Tracheal Pressure and Circulatory Modifications Induced in Guinea Pigs and Rats by Carbon Monoxide Inhalation", Comparative Biochemistry and Physiology, 59A(1) 1978, PP. 65-68.
- Mueller, F.X., L. Loeb, and W.H. Mapes, Environ. Sci. Technol. 7, 342 (1973).
- Murchio, J., H. R. Weak, W. Popendorf and W. C. Cooper, "Report on Asbestos in Clear Creek Recreation Area", V.C. Berkeley School of Pub. Hlth, Dept. of Geol, and Geophysics, 1978.
- Noggle, J.C., et al. Air Poll. Control Assn 71st Annual Meeting, 1978, abstract only.

- Pacific Gas & Electric, "Assessment of Vegetation Stress and Damage Near the Geysers Power Plant Units." Report 420-79.3, February 13, 1979, San Francisco, California.
- Pronos, J., et al. "An Elevation of Ozone Injury to Pines in the Southern Sierra Nevada", U.S. Forest Service, December 1976.
- Rasmussen, R.A., J. Air Pollut. Contr. Ass. 22, 537 (1972).
- Rasmussen, R.A., Amer. Lab. 4 (12), 55 (1972).
- Reed, W.E. "Petroleum and Anthropogenic Influence on the Composition of Sediments from the Southern California Bight", American Petroleum Institute Publication 4284, 1977, pp. 183-188.
- Rehwooldt, R.E., et al. "Residues in Hudson River Fish", Bulletin of Environmental Contamination and Toxicology 19(3) 1978, pp. 335-339.
- Riehl, H., "Introduction to the Atmosphere," 2nd ed. McGraw-Hill, New York, New York, 1972.
- Ripperton, L.A., H. Jeffries, and J.J.B. Worth, Environ. Sci. Technol. 5, 246 (1971).
- Roberts, J.D. and M.C. Casserio, "Basic Principles of Organic Chemistry." Bnejamin, New York, New York, 1967.
- Roberts, R.D. et al. "Lead Contamination of Small Mammals from Abandoned Metalliferous Mines", Environmental Pollution 15(1), January 1978, pp. 61-69.
- Robinson E. and Robbins, R.C. in "Air Pollution Control" (W. Strauss, ed.,) Part II, pp. 1-93. Wiley (Interscience), New York, New York, 1972.
- Robinson, E. and R.C. Robbins, Ann. N.Y. Acad. Sci. 174, 89 (1970).
- Sabersky, R.H., D.A. Sinema, and F.H. Shair, Environ. Sci. Technol. 7, 347 (1973).
- Schmall, R.A., "Atmospheric Quality Protection literature Review--1972," Tech. Bull. No. 65. National Council of the Paper Industry for Air and Stream Improvement, New York, New York, 1972.
- Schofield, C.L. "Acid Precipitation Effects on Fish", AMBIO, 1976, pp. 228-230.

- Schuck, E.A., J.N. Pitts, and J.K. Swan, *Int. J. Air Water Pollut.* 10, 689 (1966).
- Seizinger, D.E. and Dimitriades, B. J. *Air Pollut. Contr. Ass.* 22, 47 (1972).
- Sellers, W.D., "Physical Climatology," p. 20. Univ. of Chicago Press, Chicago, Illinois, 1965.
- Siccama, T.G. and W.H. Smith, "Lead Accumulations in a Northern Hardwood Forest", *Environmental Science and Technology* 12(5), May 1978, pp. 593-4.
- Southwest Research Institute, "Air Pollution Survey of Houston Area," Tech. Rep. No.4. Chamber of Commerce, Houston, Texas, 1957.
- Stephens, E.R., in "Chemical Reactions in the Lower and Upper Atmosphere," Stanford Research Institute (foreword by Richard D. Cadle), pp. 51-69. Wiley (Interscience), New York, New York, 1961.
- Stern, A.C., *Air Pollution: Vol I.* Academic Press, San Francisco, 1976.
- Stevens, C.M., L. Krout, D. Walling, and A. Venters, *Earth Planet. Sci. Lett.* 16, 147 (1972).
- Tamm, C.O. "Acid Precipitation: Biological Effects in Soil and On Forest Vegetation", *AMBIO*, 1976, pp. 235-238.
- Taylor, O.C., "Oxidant Air Pollution Effects on a Western Coniferous Forest Ecosystem, Annual Progress Report", Statewide Air Pollution Research Center, University of California, Riverside California, 1974.
- Thompson, C.R., E.G. Hansel, and G. Kats, J. *Air Pollut. Contr. Ass.* 23, 881 (1973).
- Tice, E.A. *J. Air Pollut. Contr. Ass.* 12, 553 (1962).
- Trayser, D.A., and F.A. Creswick, *Battelle Res. Outlook* 2 (3), 12 (1970).
- Tuesday, C.S. ed., "Chemical Reactions in Urban Atmospheres." Amer. Elsevier, New York, New York, 1971.
- Urone, P., in "Proceedings of International Symposium on Air Pollution," pp. 505-520. Union of Japanese Scientists and Engineers, Tokyo, Japan, 1972.
- U.S. Environmental Protection Agency, "Air Quality Criteria for Carbon Monoxide," No. AP-62. Research Triangle Park,, North Carolina, 1970.

- U.S. Environmental Protection Agency, "Air Quality Criteria for Hydrocarbons," No. AP-64. Research Triangle Park, North Carolina, 1970.
- U.S. Environmental Protection Agency, "Air Quality Criteria for Nitrogen Oxides," No. AP-84. Research Triangle Park, North Carolina, 1971.
- U.S. Environmental Protection Agency, "Air Quality Criteria for Photochemical Oxidants," No. AP-63. Research Triangle Park, North Carolina, 1970.
- U.S. Environmental Protection Agency, "Air Quality Criteria for Sulfur Oxides," No. AP-50. Research Triangle Park, North Carolina, 1969.
- U.S. Environmental Protection Agency, "Control Techniques for Sulfur Oxide Air Pollutants," No. AP-52. Research Triangle Park, North Carolina, 1969.
- U.S. Environmental Protection Agency, "National Ambient Air Quality Standards: States Attainment Status", March, 1978.
- U.S. Environmental Protection Agency, National Emissions Data System, Monitoring and Data Analysis Division, Office of Air Quality Planning and Standards, Research Triangle park, North Carolina 27711
- U.S. Environmental Protection Agency, Region IV. Air Pollution Control Office, Atlanta, Georgia (private communication).
- U.S. Environmental Protection Agency, "Validation of Improved Chemical Methods for Sulfur Oxides Measurements from Stationary Sources," No R2-72-105. J. N. Driscoll, Program Manager, Walden Research Corp., Nat. Tech. Inform. Serv., Springfield, Virginia, 1972.
- Vandermeulen, J.H. "Effects of Petroleum Hydrocarbons on Algal Physiology: Review and Progress Report", Society for Experimental Biology Seminar Series 2, 1976, pp. 107-125.
- Weinstock, B., Science 176, 290 (1972).
- Williams, W.T., et al. "Air Pollution Damage to the Sierra Nevada Mountains of California", Journal of the Air Pollution Control Association, 3/77, Vol. 27, No. 3, pp. 230-234.
- Yankel, A.J. et al. "The Siver Valley Lead Study: The Relationship between Childhood Blood Lead Levels and Environmental Exposure", Air Pollution Control Association Journal 28(8), August 1977, pp. 763-767.

6. AIR QUALITY REGULATIONS

6.1 EXECUTIVE SUMMARY

6.1.1 Background

The Clean Air Act, as amended in 1977, is the primary legislative tool for improving and monitoring air quality in the United States. Many requirements of the act apply to BLM activities, as well as to those of the Fish and Wildlife Service, the National Park Service and the National Forest Service.

The Clean Air Act was originally passed in 1955 and numerous amendments have been initiated over the past 25 years. Under the 1970 amendments, for example, specific limits for pollutant levels were established including dates for compliance. These pollutant levels, called the National Ambient Air Quality Standards (NAAQS) were based upon air "quality" effects on health. The 1970 Act mandated the states to formulate plans to achieve compliance with the ambient standards. These plans, known as State Implementation Plans (SIPs), required state transportation control plans, emissions limits for specific categories of sources, and permit rules for new or modified sources of air pollution.

Once these plans were adopted by the state, and approved by the EPA, they were binding as law. The state then had the jurisdictional authority to enforce the regulations under the plan. If a state was found by the EPA to be deficient in its administration of the plan, the EPA was able to intervene and administer the plan until it felt that the state could once again resume adequate control of the program(s). It should be noted that this concept has remained in the latest amendments to the Act.

On August 7, 1977, Congress again passed amendments to the Clean Air Act (CAAA). These amendments significantly altered approaches to maintaining and achieving the adopted Air Quality Standards. The three most substantial alterations to the act are considered to be (1) New Source Review Requirement (NSR) (2) Prevention of Significant Deterioration (PSD), and (3) the requirement that states, by July 1979, again design programs (SIP) for achieving the NAAQS. Note that items (1) and (2) are an integral part of the State plan (3);.

The CAAA also extended the original deadlines for achieving the NAAQS to December 1982, with provisions for extending compliance to 1987 for areas with severe oxidant and/or carbon monoxide problems. Furthermore congress empowered EPA to implement sanctions if a state did not have an acceptable SIP by July 1979. The major sanctions that the EPA is able to impose are: ban construction of major sources in a non-attainment areas, and withholding Federal funding for projects such as highway and sewage facilities. As part of an acceptable SIP; a state

which requests an extension of the ozone and/or carbon monoxide compliance date, must implement a statewide motor vehicle inspection and maintenance (I/M) program.

A number of areas in California have requested an extension to the oxidant and CO NAAQS to 1987 (e.g., Los Angeles, San Diego, etc.). However, due to the reluctance of the California Legislature to adopt a statewide I/M program, the California SIP is in jeopardy of being rejected. As of July 1, 1979, new major sources (and certain modifications to existing major sources) are prohibited from locating in non-attainment areas of the state. Additionally, if the Legislature does not adopt an I/M program prior to the time (s) EPA's conditional approval(s) expire, then Federal Highway & Sewage funding will also be withheld.

6.1.2 Permit Rules for New or Modified Sources

Since 1970, the Clean Air Act has required that any new, or modified source(s) of air pollution undergo a preconstruction review. The purpose of this review is to ensure that such sources would not violate any ambient standard or contribute to any existing violations of these standards. This review is known as New Source Review, and has been expanded by the Amendments of 1977.

6.1.2.1 Nonattainment Areas

In nonattainment areas (areas that do not meet the NAAQS), states are required to develop permit rules which meet the requirements of the CAAA. Specifically, these permit rules must require the following: (1) new or modified source locating in a non-attainment area obtain a high degree of emission control (called Lowest Achievable Emission Rate or LAER) for the problem pollutant(s) and (2) obtain emission reductions of that pollutant, called emission offsets or tradeoffs. Tradeoffs are generally obtained by retrofitting existing sources with air pollution control equipment, or by "retiring" older units.

Because of the permit moratorium for nonattainment areas, sources wishing to locate in such areas may not receive permits until the nonattainment portion of the SIP has been approved by the EPA.

The State of California has numerous non-attainment areas; and as such a majority of the State Implementation Plan consists of "plans" or "tactics" to bring the affected regions (air basins) into compliance with the NAAQS.

6.1.2.2 Attainment Areas and Prevention of Significant Deterioration Review

In attainment areas (areas in which the air quality is better than the NAAQS), the Clean Air Act amendments require SIPs to contain a special permit program for new or modified sources.

This permit program, is called Prevention of Significant Deterioration of Air Quality. As a result of this requirement, the EPA, on June 19, 1978, promulgated the Prevention of Significant Deterioration (PSD) regulations. The basic intent of these regulations is to keep "clean air clean." This is accomplished by placing ambient air quality limitations for SO₂ and particulate matter in addition to the NAAQS which have been established for these pollutants. The increase in ambient concentration of these two pollutants from a given baseline concentration is limited by what are called "increments." These increments differ depending on the class designation of the area in which the new or modified source is attempting to locate (see Figure 6.1-1).

The Clean Air Act and the PSD regulations established three "classes" of clean air areas. Each class has been assigned numerical increments for particulate matter and sulfur dioxide concentrations and increments will be set in the near future for all other criteria pollutants. These increments indicate the limit of ambient concentration increase above baseline concentration which will be allowed in each particular "class" area.

Class I increments allow only minor air quality increases; Class II increments allow a moderate amount of deterioration, and Class III increments allow the most air quality deterioration; although violations of the NAAQS are never permitted. Class I areas include national memorials and national wilderness areas exceeding 6,000 acres in size.

Sources subject to PSD must use Best Available Control Technology (BACT) on the proposed new sources or modified source and furthermore, must demonstrate that the emissions will not result in concentrations in excess of the PSD increments for SO₂ and particulate matter. The most important aspect of these regulations is that increment consumption is viewed from a cumulative viewpoint. That is, if a source consumes part of the increment, then the next source to apply for a permit(s) must work within the remaining portion of the increment. Thus, it is possible for the increment to be "used up" in a particular area. Increment consumption is granted on a first-come, first-serve basis.

6.1.2.3 Role of the Federal Land Manager in the Permit Review Process

Federal Land Managers (FLM) have input to the PSD permitting process if a project will have an impact on a Class I area. Once a source makes an application to the EPA, the EPA must make a determination as to the probable impacts the project will have. As early as possible, the EPA must contact the appropriate FLM if it is thought that the project will have an impact on a Class I area. The FLM may then review all air quality studies performed in conjunction with the EPA permit application within the 60 day review period. If the FLM finds that the facility would have an adverse impact on the "air quality related

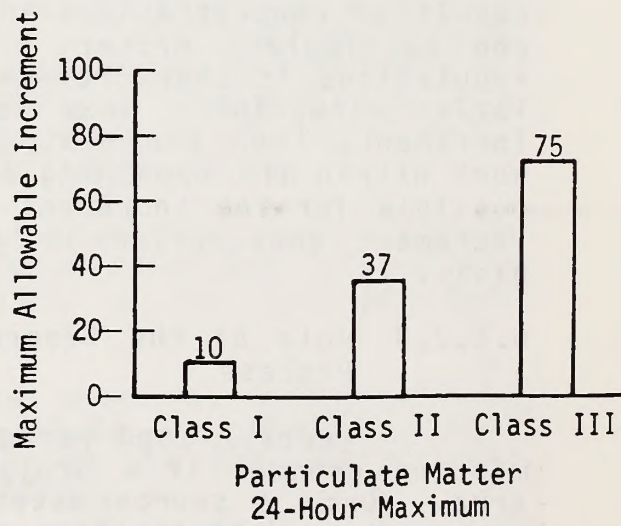
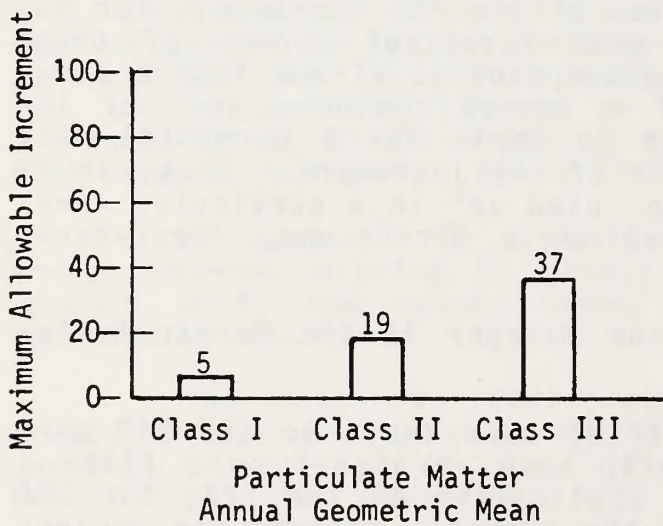
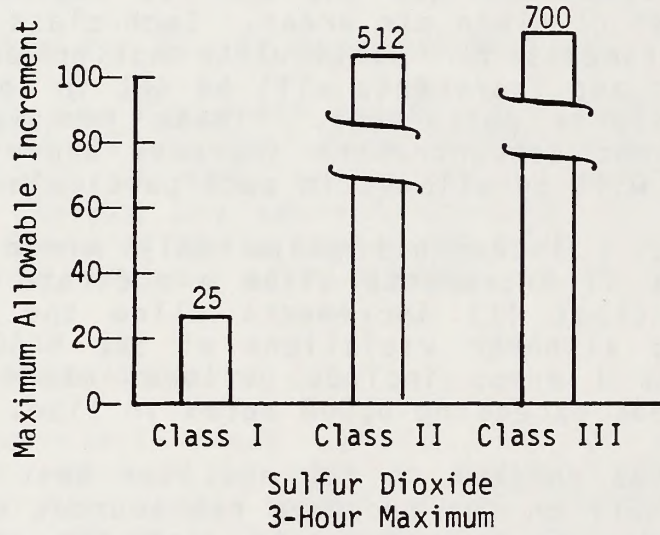
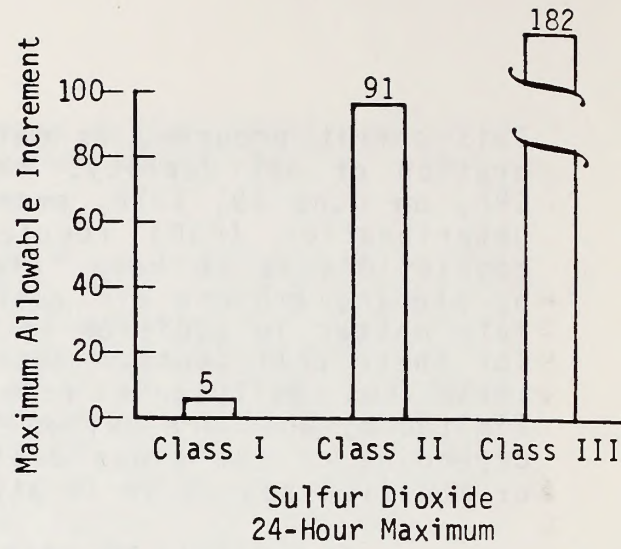
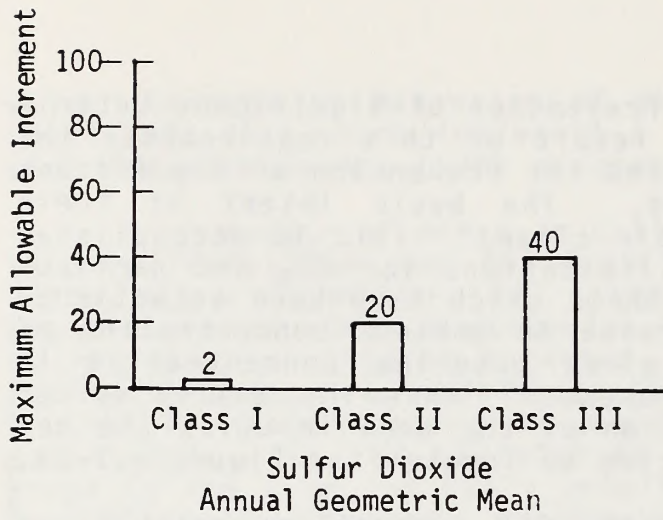

Figure 6.1-1
Prevention of Significant Deterioration
Maximum Allowable Increments as a Function of Class Designation
($\mu\text{g}/\text{m}^3$)

values" of the land area, a permit cannot be issued. The source must then demonstrate that no adverse impact would occur. Denial by the FLM may be made even if the Class I increments are demonstrated not to be exceeded by the project.

It is important to note that if the FLM proposes activities on land within his jurisdiction, the available increment must not be exceeded. This may inhibit future land management decisions, and should be considered in the early part of the decision process.

6.1.2.4 Role of the Federal Land Manager in Class Redesignation Procedures

The FLM also has a minor role in the process of redesignating a particular class area (for example, a Class II area to be redesignated to a Class I area). Redesignations may only be proposed by the state or by an Indian Governing Body; if the area to be redesignated contains federal lands, the FLM is to be notified of the proposal. The FLM will be allowed to comment on the proposal, and if he is opposed to it but the state wishes to continue to pursue it, he must be provided with an explanation of the reasons why the state feels it should be redesignated. The FLM may also provide input at the public hearing which is required for all redesignations; however, the state has the ultimate authority.

6.1.3 Visibility Protection

The 1977 Amendments added to the Clean Air Act a section entitled "Visibility Protection for Federal Class I Areas". This section declares as a national goal "the prevention of any future, and the remedying of any existing, impairment of visibility in mandatory Class I Federal areas" where impairment results from man-made air pollution. Such a list of Mandatory Class I federal areas was first published in the November 3, 1977 Federal Register and was revised on Nov. 30, 1979. Those areas so designated are presented in Table 6.4-2 and Figure 6.4-1, respectively. The Amendments also required that by February 1978, the Secretary of Interior, in consultation with the States and the FLM's, identify any mandatory Class I areas where visibility contributes significant values to that particular area. These areas were published in the February 24, 1978 Federal Register. As such, all Class I areas are areas in which visibility is an important value. The EPA, by February 1979, was to have completed a study and report to Congress on available methods for implementing this national goal. This document was noticed in the Nov. 30, 1979 Federal Register and was not available in time to be addressed in this report. Additionally, the EPA was authorized to promulgate regulations requiring retrofits on specified pieces of equipment so that visibility would be maintained, or enhanced. The FLM must be consulted with regard to these regulations.

6.1.4 Emission Standards

The Clean Air Act gave the EPA the authority to promulgate emission standards for specific categories of equipment. It also gave EPA the authority to designate certain pollutants as "hazardous", and to set emission standards for such hazardous pollutants for specific categories of equipment.

The EPA has promulgated New Source Performance Standards (NSPS) and National Emission Standards for Hazardous Air Pollutants (NESHAPS). The NSPS standards presently consist of emission limits of pollutants for 28 sources categories. The NESHAPS have been established for mercury, beryllium, asbestos, vinyl and chloride (a NESHAPS for benzene has been proposed).

6.1.5 State Regulations

6.1.5.1 Permit Rules

As previously discussed, a major intent of the Clean Air Act was to establish procedures for permit rules; and require states to adopt such rules as part of their SIP. Until such time as these rules are approved by the EPA, and incorporated in the SIP, the EPA still retains permitting authority over affected sources.

The lead state agency in California is the Air Resources Board (ARB). ARB is responsible for coordinating the SIP and has exclusive authority over mobile sources. Additionally, it monitors local agency (County Air Pollution Control Districts) activities over stationary sources, and also conducts compliance tests.

ARB also adopts moral rules governing all sources, and encourages the local districts to adopt similar rules, so that there is a degree of uniformity throughout the state. Note, however, as discussed in Section 6.5, local districts tend to adopt rules which reflect the nature of the area (i.e., industrial vs. rural).

As defined in the Clean Air Act Amendments of 1977, the Federal Land Manager (FLM) for the BLM has the responsibility to protect the air quality related values of lands within his jurisdiction. This responsibility must be addressed in a number of programs including protection of visibility, fire management, oil and gas leasing, land use planning of Federal lands, issuance of right-of-way permits, and the preparation of Environmental Impact Statements (EIS's) attendant to such permits. Land management by the BLM is primarily concerned with recreational areas (e.g., wilderness areas) but the concerns of the land manager are certainly not limited to these aspects. For example, oil wells, or gas pipelines which are on Federal lands, come under the jurisdiction of the FLM. In order for the Manager to issue a BLM permit for such activities, he must ascertain that the owner or operator of the project has obtained all necessary state, local and federal permits. These include environmental permits in many cases. Thus, it is imperative for the FLM to be familiar with the legislative and regulatory aspects of air quality in addition to the baseline meteorology and air quality with which the permit is concerned. An understanding of the rudiments of the air quality review processes in California can be helpful in the preparation of future EIS's, since many applicants are required by law to prepare air quality assessments to obtain project approval. Such assessments could be used by the FLM in preparation of an EIS and in making a final decision.

In recent years, the role of the FLM in the protection of air quality has increased. Recent federal legislation has provided increasingly stringent restrictions to protect the clean air resource from further deterioration by new or modified sources. The 1977 Amendments require the FLM to take an active role in the EPA's PSD permit process, specifically, the Clean Air Act has given the FLM the authority to comment on projects which impact the air quality in areas designated as Class I (i.e., national parks, monuments or wilderness areas in excess of 6,000 acres, or any other area designated by the State as a Class I Area). In the words of the Act, the FLM must actively protect the "air quality related values including visibility" of such lands and may oppose programs felt to be deleterious to Class I areas.

The Act also authorizes the FLM to take an affirmative role in visibility protection in these areas, as well as taking part in altering the Class designation of any area incorporating federal lands.

Because "air quality related values" are one of the concerns of the FLM, it is necessary that the managers be familiar with the implications of clean air legislation as it affects federal lands. Section 6.3 discusses the federal legislative history concerning air pollution, discusses provisions of

the 1977 Amendments pertinent to federal land areas and visibility protection, and also indicates where the FLM may participate in the implementation of such provisions.

6.3 HISTORY OF AIR QUALITY LEGISLATION

Public concern for the nations air quality and for the effect that polluted air has on human health and welfare led to the passage of National Air Pollution Legislation in 1955. Amendments to this legislation were passed in 1963, 1965, 1967, 1970 and 1977 (Table 6.3-1 is a list of clean air legislation enacted by the Federal Government). Prior to the 1970 amendments, the responsibility for air quality was held by the states with the Federal Government providing little more than financial and technical assistance. Some progress toward cleaner air was achieved; however, in the opinion of a significant portion of the population, it was insufficient. As a result, the 1970 Amendments introduced the Federal Government as a regulatory force. The States remained responsible for developing air quality Implementation Plans but, under the 1970 Amendments, specific limits were set and certain pollutant concentration levels had to be achieved by stipulated dates. The specific concentration levels are called the National Ambient Air Quality Standards (NAAQS).

Two types of NAAQS were mandated by the Amendments of 1970. Primary standards set levels which allow an adequate margin of safety for public health while Secondary standards specify levels which protect the public welfare from any known or anticipated adverse effects associated with a pollutant's presence in the ambient air. Secondary effects on public welfare refer to impacts on soils, water, crops, visibility, as well as effects on economic values and on personal comfort and well being. Table 6.3-2 shows the standards at current levels. As can be seen, the secondary standards are, in most cases, more stringent, due primarily to the wide range of items included under 'public welfare' which the secondary standards must protect.

The 1977 Amendments attempted to deal with controversies that had developed concerning achievement of the regulations and the overall achievement of the goals of the Clean Air Act. The energy shortage and the cost and development of air quality control equipment on both stationary and mobile sources caused industry to seek delays in achieving mandatory standards. Environmental organizations, through the use of the judicial system, had forced the EPA to promulgate legislation to prevent the significant deterioration of air quality in regions of the country where the air was cleaner than the established standards. Promulgation of the original PSD regulations brought opposition from persons concerned about such issues as industrial growth, employment, the economy and EPA authority. These and other concerns influenced the Congress to consider amending the Clean Air Act; to establish new deadlines for achieving certain standards, and to resolve the PSD issue.

Table 6.3-1
Clean Air Legislation Enacted by the Federal Government

Date	Public Law	Purpose of Law
6/55	84-159	Provide research and technical assistance relating to air pollution control.
9/59	86-365	Extend the Federal Air Pollution Control Law PL 84-159.
6/60	86-493	Direct the Surgeon General to study and report on health effects of automobile emissions.
12/63	88-206	Improve, strengthen and accelerate programs for the prevention and abatement of air pollution.
10/65	89-272	(Title: Motor Vehicle Air Pollution Control Act). Require standards for automobile emissions and authorize research in solid waste disposal programs.
10/66	89-675	(Title: Clean Air Act Amendments of 1966). Authorize grants to air pollution control agencies for maintenance of control programs.
11/67	90-148	(Title: Air Quality Act of 1967). Authorize planning grants, expand research relating to fuels, and authorize air quality standards.
12/69	91-190	(Title: National Environmental Policy Act). Establish the Council on Environmental Quality, direct Federal agencies to consider environmental quality regulations.
12/70	91-604	(Title: Clean Air Act Amendments of 1970). Provide a more effective program to improve the quality of air.
6/74	93-319	(Title: Energy Supply and Environmental Coordination Act). Provide means of dealing with the energy shortage.
8/77	95-95	(Title: Clean Air Act Amendments of 1977). Requires BACT review on a much expanded basis. Established PSD requirements. Required visibility be considered.

Table 6.3-2

National Primary and Secondary Ambient Air Quality Standards

Air Contaminant	Averaging Time	Federal Primary Standard	Federal Secondary Standard
Nitrogen Dioxide ^{1/}	Annual Average	100 $\mu\text{g}/\text{m}^3$ (0.05 ppm)	100 $\mu\text{g}/\text{m}^3$ (0.05 ppm)
Sulfur Dioxide	Annual Average	80 $\mu\text{g}/\text{m}^3$ (0.03 ppm)	- - -
	24-Hour	365 $\mu\text{g}/\text{m}^3$ (0.14 ppm)	- - -
	3-Hour	- - -	1300 $\mu\text{g}/\text{m}^3$ (0.5 ppm)
Suspended Particulate	Annual Geometric Mean	75 $\mu\text{g}/\text{m}^3$	60 $\mu\text{g}/\text{m}^3$
	24-Hour	260 $\mu\text{g}/\text{m}^3$	150 $\mu\text{g}/\text{m}^3$
Hydrocarbons (corrected for Methane)	3-Hour 6-9 a.m.	160 $\mu\text{g}/\text{m}^3$ (0.24 ppm) ^{2/}	160 $\mu\text{g}/\text{m}^3$ (0.24 ppm)
Photochemical Ozone (oxidant)	1-Hour	240 $\mu\text{g}/\text{m}^3$ (0.12 ppm)	240 $\mu\text{g}/\text{m}^3$ (0.12 ppm)
Carbon Monoxide	8-Hour	10 mg/m^3 (9 ppm)	10 mg/m^3 (9 ppm)
	1-Hour	40 mg/m^3 (35 ppm)	40 mg/m^3 (35 ppm)
Lead	30-Day	1.5 $\mu\text{g}/\text{m}^3$	- - -

Source: 38 Code of Federal Regulations 25678, September 14, 1973

NOTE: ppm = parts per million
 $\mu\text{g}/\text{m}^3$ = micrograms per cubic meter
 mg/m^3 = milligrams per cubic meter

^{1/} Nitrogen dioxide is the only one of the nitrogen oxides considered in the ambient standards.

^{2/} Maximum 3-hour concentration between 6-9 a.m.

6.4 SUMMARY OF THE CLEAN AIR ACT AMENDMENTS OF 1977, AND RELATED REGULATIONS

President Carter signed the Clean Air Act Amendments of 1977 (PL 95-95) into law on August 7, 1977. The Amendments add to the Clean Air Act Part C, concerning the Prevention of Significant Deterioration (PSD) of air quality and visibility enhancement. Part B adds a section on ozone protection. Part D adds provisions for State Implementation Plan requirements for non-attainment areas. In general, the PSD section establishes a scheme for protecting areas with air quality cleaner than minimum national standards and requires the EPA to promulgate a permit regulation for new or modified sources in such areas. Such regulations were promulgated on June 19, 1978 and will be discussed more fully below. These regulations are generally more comprehensive than those originally promulgated by the EPA in 1974.

The amendments continue the use of two major control schemes designed by the 1970 amendments: National Ambient Air Quality Standards (NAAQS) and New Source Performance Standards (NSPS). In the five year period from January 1971 through January 1976, the EPA promulgated emission limits, or NSPS, for 19 source categories. The amendments of 1977 increased the 19 source categories to 28. Additionally, the 1977 Amendments require EPA to update NSPS every four years.

6.4.1 National Ambient Air Quality Standards (NAAQS)

As mentioned above, the Clean Air Act amendments of 1970 mandated the EPA to promulgate primary and secondary NAAQS. The 1977 Amendments require that the EPA complete, by December 31, 1980, and at five-year intervals thereafter, a thorough review of air quality criteria, and that the National Ambient Air Quality Standards, if appropriate, be revised. The EPA is also mandated to promulgate a NAAQS for NO₂ concentrations over a measurement period of not more than three hours. It was originally due by August, 1978, but the EPA has not as yet issued such a regulation. If the EPA finds that there is no significant evidence that such a standard is needed to protect public health, such a standard will not be required to be promulgated (the Nov. 30, 1979 Federal Register indicated this decision would be made by May 1, 1980).

6.4.2 Designation of Attainment Status

The Clean Air Act Amendments of 1977 required that by December 6, 1977, every State submit to the EPA a listing of the attainment status of its Air Quality Control Regions (AQCR's) for each of the six pollutants for which a NAAQS has been established. In the March 19, 1979 and Sept 11th and 12th, 1979 issues of the Federal Register, a re-listing of all nonattainment areas, by state, were published. If an area has air quality better than the NAAQS for SO₂ and TSP, it will be designated as

an attainment area; if air quality is worse than the NAAQS, it will be designated as a nonattainment area. AQCR's may be subdivided with areas designated as "attainment", as well as areas being designated as "nonattainment". Areas for which there is insufficient information to determine whether the standards have been met will be designated as "unable to classify." Attainment/nonattainment designations will be made on a pollutant-specific basis. Thus, an area may be an attainment area for one pollutant, and a nonattainment area for another pollutant.

6.4.3 State Implementation Plans

The 1977 Amendments retained the use of the State Implementation Plan (SIP) which was originally introduced in the 1970 Amendments. All SIPs will have to be revised to implement the standards and regulations mandated by the Amendments. The SIPs as originally devised in the 1970 Amendments required transportation control plans, emission limits for specific categories of sources, and permit rules for new or modified sources of pollution. The goal of these plans, as stated above, was to ensure that the NAAQS would be met in all areas of the country.

As stated previously, the 1977 Amendments expand upon the SIP requirements, and differentiate between two different plan types:

- o Areas in which the NAAQS are being met (attainment areas)
- o Areas in which one or more of the NAAQS are being violated (nonattainment areas)

Thus, a state may have to address both concepts in developing its State Implementation Plan.

6.4.3.1 Nonattainment Areas

Under the new Amendments, states containing nonattainment areas must have submitted to the EPA by July 1, 1979, an approvable implementation plan which provides for attainment of primary standards by December 31, 1979. The plan must provide for the implementation of "reasonably available control measures" on existing stationary sources to be determined by the State. If, despite these "reasonable available control measures", a state cannot attain primary standards for carbon monoxide or photochemical oxidant before the 1982 deadline, it may request an extension to 1987. To be eligible for an extension, a vehicle inspection and maintenance program must be adopted by that state.

The Amendments also made specific requirements regarding permit rules. Since 1970, the Clean Air Act has required that any new or modified source of air pollution must undergo a pre-construction review. The purpose of this review is to ensure

that such sources would not violate any ambient standard or contribute to any existing violations of these standards. This review is known as New Source Review.

The Amendments require that in nonattainment areas, the SIP must also contain permit requirements for the review of new or modified sources which would include the requirement for such sources to achieve a "Lowest Achievable Emission Rate" (LAER) for that particular source and pollutant, and to secure emission offsets for that particular pollutant in the locality of the project.

Most importantly, the Amendments impose a permit moratorium. No permits may be issued in a nonattainment area (neither by the State nor the EPA) after July 1, 1979 unless an SIP for that area has been approved by the EPA. Thus, sources wishing to locate in such areas may not receive permits until the nonattainment portion of the SIP for that area has been approved by the EPA. Numerous states did not comply with the SIP time frames established by the Clean Air Act Amendments, and on Nov 23, 1979, EPA announced that conditional approvals for SIP's would not be extended past the time the states were originally given to correct any SIP deficiencies. No second conditional approvals would be given, and in those cases where a state has failed to meet a scheduled commitment date - the SIP would be rejected, and the sanctions authorized under the act would be imposed.

The lead state agency in California is the Air Resources Board (ARB). ARB is responsible for coordinating the SIP and has exclusive authority over mobile sources. Additionally, it monitors local agency (County Air Pollution Control Districts) activities over stationary sources, and also conducts compliance tests.

ARB also adopts moral rules governing all sources, and encourages the local districts to adopt similar rules, so that there is a degree of uniformity throughout the state. Note, however, as discussed in Section 6.5, local districts tend to adopt rules which reflect the nature of the area (i.e., industrial vs. rural).

6.4.3.2 Attainment Areas

o Prevention of Significant Deterioration (PSD)

The 1977 Amendments kept active the concept of PSD. This is a permit rule which must be incorporated into SIPs for attainment areas. It applies to specific sources which are named in the Clean Air Act and the EPA's subsequent regulation. It is essentially a New Source Review rule for those sources in attainment areas, or in those areas which have been designated as "unable to be classified", according to Section 107 of the Clean Air Act as amended.

Unlike the nonattainment areas, there is no permit moratorium imposed. The failure of a state to adopt into their SIP a permit rule incorporating the PSD requirements of the Clean Air Act, does not impose a moratorium on permits. Thus, if a SIP is not approved by the EPA in an attainment area, sources will be required to obtain such permits from the EPA, as well as obtaining any permits required by the State. When the State adopts a PSD-type rule which is approved by the EPA, then the State has the jurisdictional authority to administer it, and a source need only obtain the State permit.

The basic intent of the PSD regulations is to keep "clean air clean". This is accomplished by placing limitations on the amount that pollutant concentrations can be increased above what is termed "baseline concentration". This will be discussed in further detail below.

o Classification of Attainment Areas under PSD

The Clean Air Act, and the subsequent PSD regulations designate all attainment areas as either Class I, II or III, depending on the degree of deterioration that is to be allowed. Limits are assigned to increases in pollution concentrations for SO₂ and particulate matter for each classification (See Table 6.4-1). Class I increments allow only minor pollutant concentration increases while Class III increments allow the most concentration increases. However, in no instance may the NAAQS be exceeded.

Congress specified that certain areas were to be automatically designated Class I. These areas include national memorials, parks and wilderness areas exceeding 6,000 acres in size, already in existence by the date of enactment. A list of the Class I areas for California are presented in Table 6.4-2 and illustrated in Figure 6.4-1 (this may be viewed in conjunction with overlay G). These areas may not be redesignated.

Under PSD regulations, the remaining areas are all presently Class II. These areas may be redesignated by the states to either Class I or Class III, following the procedures outlined in the regulations, and which will be discussed in the FLM's role in the Redesignation of Area Classifications. All new Wilderness Areas must be designated as either Class I or II.

o Applicability and Review Requirements

On June 19, 1978, the EPA promulgated the requirements for PSD as required in the Clean Air Act Amendments of

Table 6.4-1
 Prevention of Significant Deterioration
 Maximum Allowable Increments
 (In Micrograms Per Cubic Meter)

Pollutant	Class I	Class II	Class III
Particulate Matter			
Annual Geometric Mean	5	19	37
24-Hour Maximum*	10	37	75
Sulfur Dioxide			
Annual Arithmetic Mean	2	20	40
24-Hour Maximum*	5	91	182
3-Hour Maximum*	25	512	700

*May be exceeded once per year

Table 6.4-2
Mandatory Class I Areas Under 1977
Clean Air Act Amendments for California

National Parks

Kings Canyon
Lassen Volcanic
Redwood
Sequoia
Yosemite

National Wilderness Areas Over 6,000 Acres

Agua Tibia
Caribou
Cucamonga
Death Valley
Desolation
Dome Land
Emigrant
Hoover
Joshua Tree
John Muir
Kaiser
Lava Beds
Marble Mountain
Minarets
Mokelumne
Pinnacles
Point Reyes
Salmon Trinity Alps
San Gabriel
San Jacinto
San Rafael
South Warner
Thousand Lakes
Ventana
Yolla-Bolly Middle Eel

1977. THE FOLLOWING DISCUSSION IS BASED ON THE PSD REQUIREMENTS AS CONTAINED THEREIN. Appendix A contains a summary analysis of the data as of 1977 as listed by the State of California.



Figure 6.4-1
Mandatory Class I Areas in the Susanville District

1977. THE FOLLOWING DISCUSSION IS BASED ON THE PSD REQUIREMENTS AS CONTAINED THEREIN. Appendix H contains a summary analysis of the June 18, 1979 decision by the United States Court of Appeals, D.C. Circuit regarding Alabama Power Co. versus USEPA. This case will significantly impact PSD regulations as indicated in the Appendix. It should be noted that in December, 1979, the Court issued its final decision regarding the PSD regulations, however, due to time constraints an analysis of that decision is not incorporated in this report.

The CAAA of 1977 gave detailed requirements to assist states in the modification of their SIP's to conform with the Amendments. Twenty-eight source categories have been specified as subject to the PSD regulations and are listed in Table 6.4-3. A source included in the 28 source categories having potential emissions (uncontrolled) greater than 100 tons/yr for a pollutant is a major PSD source for that pollutant, (provided the area in which the source is locating is attainment for that pollutant; otherwise, it is subject to nonattainment rules).

In addition to the 28 categories specified, there is also a "catch-all" category. Sources having potential (uncontrolled) emissions greater than 250 tons/yr are major PSD sources for that pollutant (provided, once more, that the area in which the source is locating is an attainment area for that pollutant).

Major PSD sources must apply Best Available Control Technology (BACT) for each applicable pollutant and undergo an air quality analysis. BACT means an emission limit or control technology representing the maximum degree of reduction with respect to a particular source and pollutant, taking into account: energy, environmental and economic impacts, and technical feasibility. This determination is made by the EPA, but demonstration made by the Applicant will be considered.

If, after application of BACT, the pollutant levels are greater than 50 tons/yr, 1,000 lbs/day or 100 lbs/hr (whichever is the most stringent), an air quality analysis must be performed. The PSD regulations require that a source demonstrate that no violations of NAAQS for NO₂, CO and HC will occur (assumed that the area under consideration is in attainment for these pollutants). While NO₂, CO and HC concentrations can, in effect, be increased to the respective NAAQS, SO₂ and particulate matter, increases are limited by "increments" above the "baseline concentration". The "increments" are defined by the PSD Class designation for the area in which the source is located.

Table 6.4-3

PSD Major Stationary Sources

Potential Emission of Any Pollutant Greater than 100 tons/yr

Fossil-Fuel Fired Steam Electric Plants
(More than 250 MMBTU/Hr Input)

Coal Cleaning Plants (with Thermal Dryers)

Kraft Pulp Mills

Portland Cement Plants

Primary Zinc Smelters

Iron and Steel Mill Plants

Primary Aluminum Ore Reduction Plants

Primary Copper Smelters

Municipal Incinerators

(Capable of Charging More than 250 Tons Refuse/Day)

Hydrofluoric, Sulfur and Nitric Acid Plants

Petroleum Refineries

Lime Plants

Phosphate Rock Processing Plants

Coke Oven Batteries

Sulfur Recovery Plants

Carbon Black Plants (Furnace Process)

Primary Lead Smelters

Fuel Conversion Plants

Sintering Plants

Secondary Metal Production Plants

Chemical Process Plants

Fossil Fuel Boilers (or Combinations Thereof)

(With Total Storage Capacity Exceeding 300 Thousand BBLs)

Taconite Ore Processing Plants

Glass Fiber Processing Plants

Charcoal Products Plants

and

Notwithstanding the sources above, any source which emits or has potential to emit 250 tons/yr or more of any pollutant regulated under the act.

Baseline concentration is essentially the air quality, or concentration level of SO₂ and particulate matter that "existed" on August 7, 1977. Thus, the emissions from a proposed source are "modeled" via computer simulation, and a concentration prediction is obtained. The SO₂ and/or particulate matter concentration obtained must not exceed the incremental PSD limit for the area in which the source is locating; furthermore the concentration obtained (or "used") is applied against the increment. This means increment consumption is cumulative. That is, if emissions from the source result in SO₂ and particulate concentrations which consume part of the increment allowed from the "baseline concentration", then the next source(s) to apply for PSD permits must work within the remaining increment (See Figure 6.4-2).

It should be noted that SO₂ and particulate concentrations are prohibited from exceeding the NAAQS. Thus, if a "baseline concentration" is close to the NAAQS, and the additional "increment" defined by the values in Table 6.4-1 would exceed the NAAQS, the then NAAQS becomes the upper limit, and the increment is "reduced" accordingly.

Federal Land Manager's Role in Class I Area Reviews

o Denial; impact on air quality related values

FLM's have input to the PSD permitting process if a project is believed to have an impact on a Class I area. Once a PSD application is submitted, the EPA must contact the appropriate FLM if it is believed that the project will have any air quality impact on a Class I area.

If the FLM finds that emissions from a proposed facility would have an adverse impact on "air quality related values" (which include visibility) of the land area (even though allowable Class I increments would not be exceeded), he can recommend to the EPA that the permit be denied. If the EPA concurs with the FLM's demonstration, a permit will not be issued.

o Class I variances

Conversely, in a situation where Class I increments are predicted to be exceeded, the applicant may appeal to the FLM. The applicant must demonstrate to the FLM that the emissions from the facility will not adversely impact air quality related values. If the FLM concurs with this demonstration, he must certify this concurrence, and the state may then authorize the EPA to issue a permit which would allow the facility to comply with less stringent air quality increments. In such cases,

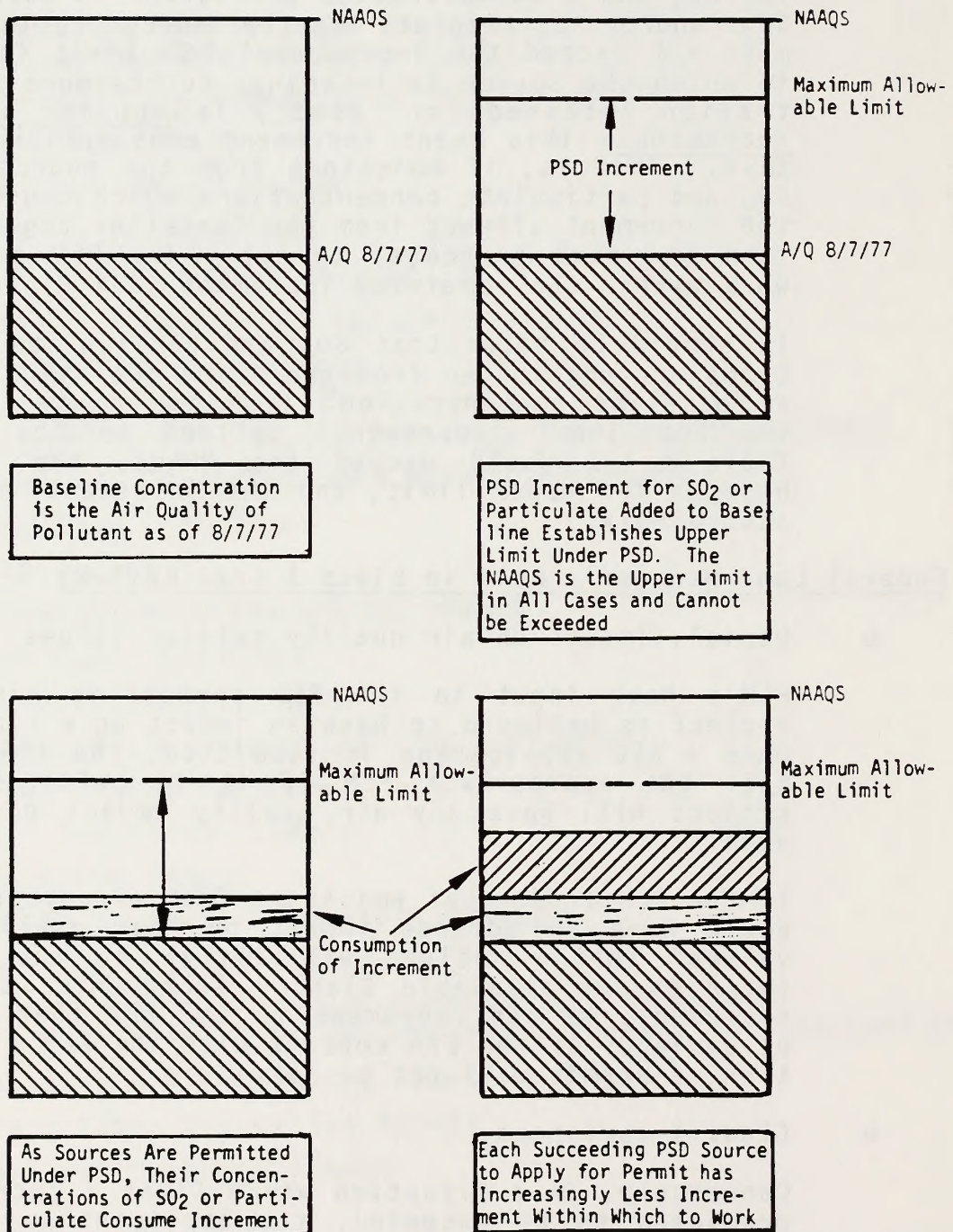

Figure 6.4-2
 Determination of Maximum Allowable Ambient
 Limit Under PSD Increment

the maximum increments imposed are the same as the Class II values, except for the three-hour SO₂ increment limit which is not to exceed 325 µg/m³ (The Class II three-hour SO₂ increment is 512 µg/m³.)

- o SO₂ variance by Governor with FLM's concurrence.

In situations where the Class I increments are predicted to be exceeded, and the source would exceed the relaxed SO₂ increments as described above, the applicant may appeal to the Governor to receive a variance for sulfur dioxide only. (Particulate matter variances cannot be made.) In making this appeal, the applicant must demonstrate that neither the 24-hour nor the 3-hour SO₂ increment limits can be achieved. The annual SO₂ increment of 20 µg/m³ must be met, however. Additionally the applicant must also demonstrate that the project will not adversely affect the air quality related values of the affected area. The FLM, again, has input in this process and is required to make a recommendation to the Governor who can agree or disagree with the FLM recommendation. In addition, a public hearing must be held. After considering the public input, the Governor, may grant a variance. The EPA can then issue a permit, and the source would then be permitted to exceed the SO₂ increments presented in Table 6.4-4 for no more than 18 days per year.

- o Variance by the Governor with the President's concurrence

If, in the above process, the FLM does not concur, the permit can not be approved, unless the Governor overrides the FLM's veto. The Governor is authorized to override this veto and recommend a variance. In such a situation, the recommendations of both the FLM and the Governor are sent to the President. The President may approve the Governor's recommendation if he finds the variance to be in the national interest. If the variance is approved, the EPA may issue a permit, and the source would then be permitted to exceed the SO₂ increments presented in Table 6.4-4 for no more than 18 days per year.

The procedure discussed above is outlined in Figure 6.4-3.

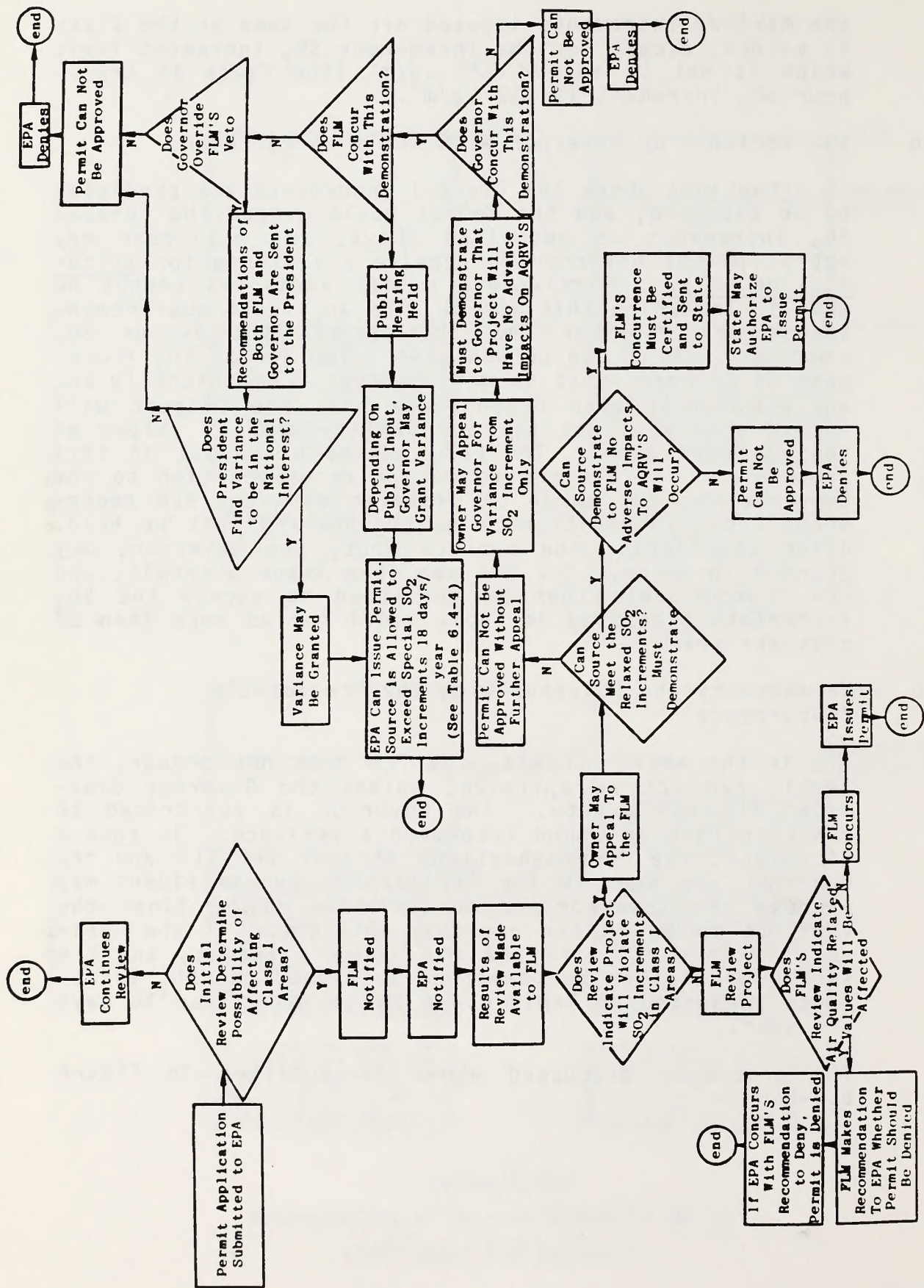

Figure 6.4-3
The PSD Permit Application Process

Table 6.4-4

Maximum Allowable Increase ($\mu\text{gm}/^3$)
Under Class I SO_2 Variances

<u>Period of Exposure</u>	<u>Terrain</u>	<u>Areas</u>
	<u>Low</u>	<u>High</u>
24-hour maximum	36	62
3-hour maximum	130	221

o Air Quality Related Values

The only "air quality related value" specifically cited in the 1977 Amendments is visibility. Other values may include fish and wildlife resources, vegetation, archaeological sites and soil impacts. The EPA has yet to provide general guidelines regarding the evaluation of impacts of proposed emitting sources on "air quality related values" and until such guidance is available, determinations are to be made on a case-by-case basis. The FLM reviewing the permit can recommend conditions which would ensure protection of air quality related values. For example, a condition that the facility monitor the impacts of its emissions, and reduce their level if adverse effects begin to occur.

FLM role in Redesignation of Area Classifications

A state may redesignate any area to Class I. States are also permitted to redesignate certain areas to Class III except the following areas greater than 10,000 acres in size: present national monuments, primitive areas, recreation areas, wild and scenic rivers, wildlife refuges, lakeshores and seashores, and future national parks and wilderness areas. Redesignation of an area to Class III is a complicated process requiring approval by the governor, public notices and hearings, consultation with the state legislature, and approval by a majority of potentially affected local residents.

Detailed analysis is required prior to public hearing including health, environmental, economic, social and energy impacts of the proposal. Redesignation of areas within Indian reservations may only be done by the applicable Indian governing body.

The EPA Administrator may disapprove a proposed redesignation only if the redesignation does not meet the procedural requirements of Part C of the Act. If federal lands are included in the proposed redesignation area, the FLM is to submit recom-

mendations on the proposal, but the state's decision, if it differs, is binding. The EPA may be requested to resolve disputes between states and Indian tribes on proposed redesignations. The redesignation process is summarized in Figure 6.4-4.

6.4.4 Visibility Protection

The 1977 Amendments added to the Clean Air Act a section entitled "Visibility Protection for Federal Class I Areas". This section declares as a National goal "the prevention of any future, and the remedying of any existing, impairment of visibility in mandatory Class I Federal areas" where impairment results from man-made air pollution. The Amendments also required that by February 1978, the Secretary of Interior, in consultation with the states and the FLM's, are to identify any mandatory Class I areas where visibility contributes significant values to the area. These areas were published in the February 24, 1978 Federal Register. As such, all Class I areas in Wyoming are areas in which visibility is considered to be an "important" value. As stated previously, the EPA was to have conducted a study on visibility (by Feb 1979), and promulgate regulations on visibility by August, 1979.

These regulations, in essence, are to provide guidelines to the states on the various techniques and methods to be used to achieve the National goal for visibility. Such a goal would be stated, in all probability, as a "visibility standard".

The regulations would identify "impaired visibility areas" and would require each SIP in such areas to adopt emission limits on sources of pollution, compliance schedules and other measures necessary to achieve the visibility standard. These measures will include what the Clean Air Act terms "Best Available Retrofit Technology" (BART). Thus, SIPs must impose BART on specific sources named in the Clean Air Act. These sources consist of the sources in the 28 PSD categories, which have potential (uncontrolled) emissions greater than 250 tons/yr of any pollutant. In addition to these measures, the SIPs must develop long-term strategies for achieving the visibility standard.

The EPA is allowed to exempt sources from BART; such exemptions can be made if the EPA feels that such sources will not contribute to visibility impairment. The EPA may not however, give this source-wide exemption to fossil-fuel fired power plants greater than 750 MW. These units would be included in the States' regulations and BART must apply. Exemptions for these units may only be made on a case-by-case basis, where the owner of such units demonstrates to the EPA that the unit of concern would not contribute to impairment of visibility. :

Any exemption that the EPA makes regarding these sources and their inclusion in the SIP, must go through the FLM. The

Figure 6.4-4
Redesignation Procedure

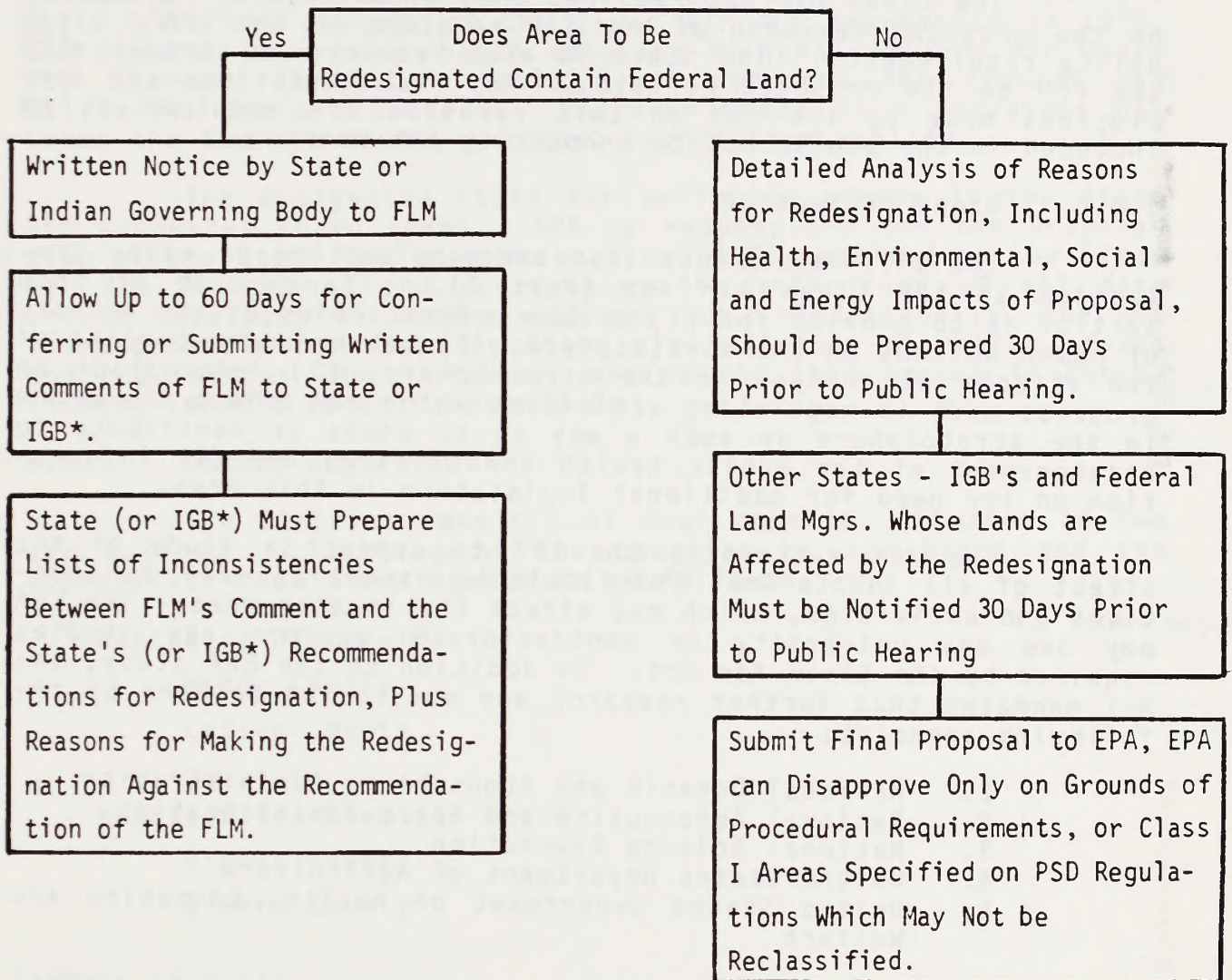

* Indian Governing Body

Clean Air Act mandates that the FLM's concurrence must be obtained in order for any exemption of this type to be effective. (Section 169A(c)(3) of the Clean Air Act).

The Clean Air Act requires that a public hearing be held on the proposed revision of any SIP relating to the EPA's visibility requirements. The State is also required to consult with the FLM on the proposed revision. Any recommendations and conclusions made by the FLM on this revision are required to be included in the public notice announcing the hearing.

6.4.5 Ozone Protection

The 1977 Amendments also added a section on ozone protection to the Clean Air Act (Part B). The purpose of this section is to provide for (1) better understanding of the effects of human actions on the stratosphere; (2) better understanding of the effects of changes in the stratosphere; (3) information on progress made in regulating activities which may affect the ozone in the stratosphere in such a way as to cause or contribute to endangerment of the public health and welfare; and (4) information on the need for additional legislation in this area.

The Act authorizes the EPA to conduct a study of the effect of all substances, (particularly ozone) as well as practices and activities, which may affect the stratosphere. The EPA may use any university or contractor to perform the studies required by the Clean Air Act. In addition to the EPA study, the Act mandates that further research and monitoring be done by the following agencies:

1. National Oceanic and Atmospheric Administration
2. National Aeronautics and Space Administration
3. National Science Foundation
4. United States Department of Agriculture
5. United States Department of Health, Education and Welfare

Authorization is given to the EPA to write regulations to control any substance which the EPA believes, based on their studies, would affect the stratosphere, particularly in the formation of the ozone. This would include chlorofluorocarbon emissions from aerosol cans and emissions from airplanes, cars, etc. These regulations must take into account the feasibility and the costs of achieving these controls. However, such regulations may exempt medical use products for which the EPA determines there is no suitable substitute.

:

6.5 STATE AND COUNTY REGULATIONS

6.5.1 State Ambient Air Quality Standards

The State of California began establishing Air Quality Standards in 1969 under the provisions of the Mulford-Carrell Act. With the passage of the Clean Air Act Amendments in 1970, the Federal Government began adopting National Ambient Air Quality Standard (NAAQS). Table 6.5-1 compares the Federal and California State Standards. Wherever there is a variation between the two standards, the most restrictive applies.

The designated State air pollution agency is the State Air Resources Board (ARB). ARB is responsible for the preparation of the State Implementation Plan (SIP) required by the Clean Air Act Amendments and coordinates the activities of all districts necessary to comply with the Act. Additionally, the ARB is responsible for adopting State air pollution standards, rules and regulations (Model Rules), and is the lead agency in establishing Vehicle Emission Standards.

6.5.2 County Regulations

The District consists of four counties situated in two air basins. A listing of the counties by air basin and the appropriate regulatory agency is as follows:

Northeast Plateau Basin

Modoc County

Lassen County

Mountain Counties Air Basin

Plumas County

Sierra County

The counties in this BLM District have very low density populations and hence do not have elaborate rules/regulations. The following discussions provide an overview of the current regulatory requirements.

6.5.3 Permit Rules

As discussed previously, the intent of the Clean Air Act in establishing procedures for permit rules is to require states to adopt such rules and incorporate them in the SIP. Until such time as these rules are approved by EPA, as part of the SIP review, EPA still remains the lead permitting authority. Due to the fact that California currently does not have an approved SIP,

Table 6.5-1
Ambient Air Quality Standards

Pollutant	Averaging Time	California Standards ¹		National Standards ²		
		Concentration ³	Method ⁴	Primary ^{3, 5}	Secondary ^{3, 6}	Method ⁷
Oxidant (Ozone)	1 hour	0.10 ppm (200 ug/m ³)	Ultraviolet Photometry	240 ug/m ³ (0.12 ppm)	Same as Primary Std.	Chemiluminescent Method
Carbon Monoxide	12 hour	10 ppm (11 mg/m ³)	Non-Dispersive Infrared Spectroscopy	—	Same as Primary Standards	Non-Dispersive Infrared Spectroscopy
	8 hour	—		10 mg/m ³ (9 ppm)		
	1 hour	40 ppm (46 mg/m ³)		40 mg/m ³ (35 ppm)		
Nitrogen Dioxide	Annual Average	—	Saltzman Method	100 ug/m ³ (0.05 ppm)	Same as Primary Standards	Proposed: Modified J-H Saltzman (O ₃ corr.) Chemiluminescent
	1 hour	0.25 ppm (470 ug/m ³)		—		
Sulfur Dioxide	Annual Average	—	Conductimetric Method	80 ug/m ³ (0.03 ppm)	—	Pararosaniline Method
	24 hour	0.05 ppm (131 ug/m ³) ⁹		365 ug/m ³ (0.14 ppm)	—	
	3 hour	—		—	1300 ug/m ³ (0.5 ppm)	
	1 hour	0.5 ppm (1310 ug/m ³)		—	—	
Suspended Particulate Matter	Annual Geometric Mean	60 ug/m ³	High Volume Sampling	75 ug/m ³	60 ug/m ³	High Volume Sampling
	24 hour	100 ug/m ³		260 ug/m ³	150 ug/m ³	
Sulfates	24 hour	25 ug/m ³	AHL Method No. 61	—	—	—
Lead	30 Day Average	1.5 ug/m ³	AHL Method No. 54	1.5 ug/m ³	—	High Volume Sampling
Hydrogen Sulfide	1 hour	0.03 ppm (42 ug/m ³)	Cadmium Hydroxide Straction Method	—	—	—
Hydrocarbons (Corrected for Methane)	3 hour (6-9 a.m.)	—	—	160 ug/m ³ (0.24 ppm)	Same as Primary Standards	Flame Ionization Detection Using Gas Chromatography
Ethylene	8 hour	0.1 ppm	—	—	—	—
	1 hour	0.5 ppm				
Visibility Reducing Particles	1 observation	In sufficient amount to (8) reduce the prevailing visibility to less than 10 miles when the relative humidity is less than 70%		—	—	—
APPLICABLE ONLY IN THE LAKE TAHOE AIR BASIN:						
Carbon Monoxide	8 hour	6 ppm (7 mg/m ³)	NDIR	—	—	—
Visibility Reducing Particles	1 observation	In sufficient amount to (8) reduce the prevailing visibility to less than 30 miles when the relative humidity is less than 70%		—	—	—

Table 6.5-1 (Cont.)

NOTES:

1. California standards are values that are not to be equaled or exceeded.
2. National standards, other than those based on annual averages or annual geometric means, are not to be exceeded more than once per year.
3. Concentration expressed first in units in which it was promulgated. Equivalent units given in parentheses are based upon a reference temperature of 25°C and a reference pressure of 760 mm of mercury. All measurements of air quality are to be corrected to a reference temperature of 25°C and a reference pressure of 760 mm of Hg (1,013.2 millibar); ppm in this table refers to ppm by volume, or micromoles of pollutant per mole of gas.
4. Any equivalent procedure which can be shown to the satisfaction of the Air Resources Board to give equivalent results at or near the level of the air quality standard may be used.
5. National Primary Standards: The levels of air quality necessary, with an adequate margin of safety, to protect the public health. Each state must attain the primary standards no later than three years after that state's implementation plan is approved by the Environmental Protection Agency (EPA).
6. National Secondary Standards: The levels of air quality necessary to protect the public welfare from any known or anticipated adverse effects of a pollutant. Each state must attain the secondary standards within a "reasonable time" after implementation plan is approved by the EPA.
7. Reference method as described by the EPA. An "equivalent method" of measurement may be used but must have a "consistent relationship to the reference method" and must be approved by the EPA.
8. Prevailing visibility is defined as the greatest visibility which is attained or surpassed around at least half of the horizon circle, but not necessarily in continuous sectors.
9. At locations where the state standards for oxidant and/or suspended particulate matter are violated. Federal standards apply elsewhere.

applicants who are required to obtain a PSD permit, must obtain approval from EPA, as well as obtaining State/Local approval.

In nonattainment areas, however, no permits may be issued until the EPA has approved the SIP. As discussed previously, because of the fact that "portions" of California have requested extensions on meeting the NAAQS for oxidants and CO and due to the fact that California does not have a vehicle inspection program, the SIP must be rejected by the EPA. Accordingly, effective July 1, 1979 no new major sources are allowed to be constructed in non-attainment areas, and furthermore the state is in jeopardy of losing Federal Highway and Sewage Treatment Funding.

At the present time, many counties have rewritten their permit rules to conform with a model or guideline rule which has been developed by the ARB. Although there are individual differences between the various districts' rules regarding cut-off limits for review, control technology, etc., the basic content of the rules follows the ARB Model Rule. Thus a description of the provisions of the Model Rule often times will suffice to describe the general district requirements.

At the present time, these rewritten rules have been submitted to the ARB by the local districts. ARB is in the process of reviewing these rules to see if they conform with the Model Rule. After ARB reviews the local rule, and concurs with it, it then submits it to the EPA for review and inclusion in the SIP. A local District may not submit directly to the EPA; only the State may submit individual rules to the EPA for inclusion in the SIP.

6.5.3.1 Description of Model Rule/Districts' Rules

The ARB model rules were developed to ensure compliance with the Clean Air Act and to have a sense of uniformity throughout the State. A large majority of the local districts have adopted the rules with some minor variations between local APCD's.

The Models Rule/District Rules currently apply in both attainment and nonattainment areas (a state PSD rule will eventually be developed and be used to control sources in attainment areas). All sources, regardless of emission levels, must first demonstrate compliance with all district rules and regulations (emission limits, etc.). It must also demonstrate that all company-owned sources in the State are in compliance with all emission limitations and standards which are part of the SIP approved by the EPA.

As required by the Model Rule if the emissions from the source are greater than 250 lbs/day for any pollutant, BACT is required for all pollutants. (This may differ between districts to some degree.)

If, after application of BACT, emissions of any pollutant are greater than 250 lbs/day, the source must meet specific requirements which differ according to two different scenarios as illustrated below:

o Sources Locating in Nonattainment Areas

Offsets must be obtained for pollutants, in ratios greater than 1.2:1. These offsets must be obtained within 15 miles of the source under question. If they are obtained at distances greater than 15 miles, the ratio will be determined via computer models.

o Sources Locating in Areas which are Attainment or Show Infrequent Violations

Offsets are required only to the degree needed to prevent a new violation or to prevent the degradation of an existing one.

6.5.3.2 California's Air Conservation Program (ACP)

In 1976, the ARB began writing a proposed guideline permit rule affecting new or modified sources locating in attainment areas of the State. It was the State's version of the EPA's PSD program, and was called the California Air Conservation Program (ACP). The ARB had drafted a rule incorporating a four-level classification system of lands, as opposed to the EPA's three-class increment system.

However, since the Clean Air Act Amendments of 1977 drastically changed the PSD requirements for states, and with the rush of activity associated with nonattainment planning, the ACP for the State was temporarily dropped.

Activity resumed recently on drafting the California version of PSD. However, at this time, the rule is being written to be equivalent to the EPA's present PSD regulations, and will not contain extensive additions, or differences, as in the original version. The ARB's purpose in their actions is to draft a rule that the local districts can easily adopt and which would be easily approvable by the EPA. The rule would then be part of the SIP, and could be enforced by the local districts.

Subsequent to inclusion in the SIP, the ARB will then commence work on a new version of the ACP which would eventually replace the PSD regulation. Thus, the PSD regulation serves only as an interim measure in order to obtain full State jurisdictional authority to administer permit programs in attainment areas. The ACP will, in essence, be a more detailed PSD regulation which is tailored to the air quality concerns and needs of California. It is not known at this time whether the ACP will

include the utilization of the national Class I, II, and III increment or another suitable increment standard.

6.5.3.3 Emission Regulation

The information in the following section is categorized by the pollutant causing event or by the pollutant. Each category is followed by a discussion that describes either the typical regulation as adopted by all or a vast majority of the Air Pollution Control Districts (APCDs), or the regulations as adopted by individual or groups of APCDs. The discussions are not intended to be all-inclusive; for more detailed information and for special incidences, refer to the county rules and regulations directly.

Visible Emissions

This regulation prohibits the discharge of air pollutants for more than three minutes in any hour which is as dark or darker than No. 1 on the Ringelmann Chart as published by the U.S. Bureau of Mines. Generally, the following exceptions are allowed:

- o Smoke from fires for prevention of a fire or health hazard which cannot be altered by any other means.
- o Smoke from fires for instruction of public and industrial employees in methods of fighting fire.
- o Agricultural operations used in the growing of crops or raising of fowl, animals or bees.
- o The use of an orchard or citrus grove heater which does not produce unconsumed solid carbonaceous matter at a rate in excess of one (1) gram per minutes.
- o Emissions which fail to meet the requirement solely because of the presence of uncombined water.

The Ringelmann Chart is actually a series of charts, numbered from 0 to 5, that simulate various smoke densities by presenting different percentages of black. The charts are commonly referred to by number, thus a Ringelmann No. 1 is equivalent to 20 percent black; a Ringelmann No. 5 is equivalent to 100 percent black. They are used for measuring the opacity of smoke generated from stacks and other sources by matching with the actual effluent the various numbers, or densities, indicated by the charts. Persons can be trained and certified to use the Ringelmann method using visual judgment without the use of the charts.

:

Incinerator Burning

Except for the burning of residential rubbish, a person may not burn any combustible or flammable waste in any incinerator within the boundaries of the respective APCD except in a multiple-chamber incinerator, or in equipment found by the Air Pollution Officer to be equally effective for the purpose of air pollution control.

Particulate Matter

These regulations limit the amount of particulate matter that can be discharged from a source. The limit is usually expressed in units of volume (grains per cubic foot of exhaust gas by the allowable rate of particulate emission based on the process weight of 1 lb/hr. The rate varies by APCD.

A person may not release or discharge into the atmosphere from any source or single processing unit dust, condensed fumes, or particulate matter emissions in excess of 0.1 grains per cubic foot of gas at standard conditions, except for incinerators and Wood Fired Boilers which shall meet 0.2 grains per cubic foot of gas at standard conditions. Combustion contaminants shall be calculated at 12 percent of carbon dioxide (CO₂) at standard conditions. The regulations define a "Wood Fired Boiler" as any boiler used for steam generation from which the products of combustion are directed through a flue or chimney and which derives at least 80 percent of its fuel input heat content from wood, or wood associated waste.

Sulfur Compounds

The Plumas County APCD has adopted the following emissions for sulfur compounds:

"A person shall not discharge into the atmosphere from any single source of emission whatsoever, any one or more of the contaminants, in any sulfur combination thereof, exceeding in concentration at the point of discharge:"

- o Sulfur compounds calculated as sulfur dioxide SO₂ 0.2 percent, by volume.
- o Total reduced sulfur: Pending further investigation into a rule which will be applicable to the Mountain Counties Air Basin.

Reduction of Animal Matter

This prohibits the reduction of animal matter in a source unless all generated emissions are incinerated at temperatures of not less than 1200°F for a period of not less than 0.3 seconds or processed in a manner determined by the Air Pollution

Control Officer to be equally or more effective for the purpose of air pollution control.

Nuisances

This regulation generally prohibits any source from emitting air contaminants or other material which cause injury, detriment, nuisance or property. The working of this regulation varies with the overall detail of the county or district regulations. In some cases nuisances such as odors are separated out and dealt with directly. For example, Plumas County APCD has the following exception: ... The rule does not apply to odors emanating from agricultural operations necessary for the growing of crops or raising of fowl or animals.

Orchard Heaters

The California Air Resources Board has issued a model rule which regulates the usage of orchard heaters. A majority of the districts have adopted this rule, which requires the following:

- o The heater must be approved by the CARB, and
- o Typical emission limit: one gram/minute of unconsumed solid carbonaceous material.

Miscellaneous Regulations

Other common regulations usually, but not always, included by counties and districts contain prohibitions on emissions from organic solvents, new source performance standards, emission standards for hazardous air pollutants, regulations on organic liquid loading, and regulations on loading gasoline into stationary tanks.

The respective Districts prohibit open outdoor fires for the purpose of disposal or burning of petroleum waste, demolition debris, tires, tar, trees, wood waste, or other combustible or flammable solid or liquid waste, or for metal salvage or burning of motor vehicle bodies. There are, however, exceptions to this general rule. For example, Plumas County has the following:

- o Any public fire officer is allowed to set or permit a fire when such fire is, in his opinion, necessary for any of the following purposes:
 - (a) For the purpose of the prevention of a fire hazard which cannot be abated by any other means, or
 - (b) The instruction of public employees and/or volunteer firemen in the methods of fighting fire, or

- (c) Set, pursuant to permit, on property used for industrial purposes for the purpose of instruction of employees in the methods of fighting fires, or
- (d) To set or cause to be set backfires necessary to save life or valuable property pursuant to Section 4426 of the Public Resources Code.

The regulations also require that burning permits be obtained prior to the use of open outdoor fires. These permits are to be prepared by the designated agency and/or the appropriate APCD. In most instances, the California Department of Forestry (CDF) serves as the designated agency for burning in forested areas throughout the state and, therefore, is responsible for the issuance of permits.

While the CDF serves as the designated agency for the issuance of burning permits in California, this responsibility can be further delegated to other agencies. In some instances, the BLM has been given authority by the CDF to issue permits for land areas managed by the Department of Interior. These include the Susanville and Bodie Planning Units. In these instances, BLM area managers are directly responsible for the issuance of permits and for coordination with other agencies. However, unless this authority has been properly delegated, BLM area managers are not responsible for permitting for open out door burning.

BLM area managers responsible for the administration of Department of Interior lands in California must be cognizant of the procedures necessary prior to any burning activities in these areas. The principal points of contact for the BLM area managers include the local APCD, THE CARB, the National Weather Service (NW) and the CDF. The latter agency should serve as an initial point of contact for area managers faced with the problem of burning on federal lands for the first time. CDF personnel can explain permit issuance procedures to BLM personnel and it is good practice for BLM land managers to become very familiar with this process. Table 6.5-2 provides a list of all CDF contacts within California suitable for use by BLM land managers.

The requirements for a burning permit apply to all land areas in the state with a few exceptions. Open burning for agricultural operations in the growing of crops or the raising of fowl or animals, as well as disease or pest prevention are exempt from permitting requirements above an elevation of 3,000 feet MSL. Most burning on BLM lands will be for forest management or range improvement activity and therefore would be exempt to permitting requirements above 6,000 feet MSL. Below this level, a permit will probably be required for burning on BLM lands. Other special aspects of permitting requirements include the permission to burn between the period of January through May for range management, even on no-burn days if 50 percent of the land area has been chemically treated. In addition, BLM land planners can notify the CARB seven days in advance for a major burn at an

Table 6.5-2

STATE OF CALIFORNIA
THE RESOURCES AGENCY
DEPARTMENT OF FORESTRY

DIRECTORY

Administrative Unit	Administrative Officer	Title	Street Address	Post Office	Telephone No.	P. O. Box
State Headquarters	Lewis A. Moran	Director	1416 Ninth Street	Sacramento 95814	916-445-3976	
	Larry E. Richey	Deputy Director	1416 Ninth Street	Sacramento 95814	916-445-2921	
	Frank Tonkelson	Deputy Director	1416 Ninth Street	Sacramento 95814	916-445-6650	
I. North Coast Headquarters	George Grogan	Chief	135 Ridgeway Avenue	Santa Rosa 95401	707-542-1331	Box 670
	Richard Day	Assistant Chief	135 Ridgeway Avenue	Santa Rosa 95401	707-542-1331	Box 670
Humboldt-Dei Norte Lake-Napa Mendocino Sonoma	Wm Harrington	State Forest Ranger	118 Fortuna Blvd.	Fortuna 95540	707-725-4413	Box 516
	Byron Carmiglia	State Forest Ranger	1572 Railroad Avenue	St. Helena 94574	707-963-3601	Box 73
	Thomas Nell	State Forest Ranger	17501 N. Highway 101	Willits 95480	707-459-5561	
	Frank Crossfield	State Forest Ranger	2560 W. College Ave.	Santa Rosa 95401	707-546-1544	
	Gary Todd	Chief	1000 Cypress Street	Redding 96001	916-246-6311	Box 2238
II. Sierra Cascade Headquarters	Ross Dunwoody	Assistant Chief	1000 Cypress Street	Redding 96001	916-246-6311	Box 2238
Butte Lessen-Modoc Nevada-Tuba-Placer Shasta-Trinity Siskiyou Tehama-Glenn	Robert Paulus	State Forest Ranger	176 Nelson Avenue	Oroville 95965	916-533-6365	
	Jack Burke	State Forest Ranger	Highway 36	Susanville 96130	916-257-4171	
	John Ogden	State Forest Ranger	13760 Lincoln Way	Auburn 95603	916-885-3722	
	Howard Bromwell	State Forest Ranger	1050 Parkview Avenue	Redding 96001	916-243-1436	
	Richard Miralles	State Forest Ranger	Fair Lane Road	Yreka 96097	916-842-3516	Box 128
	Robert Kersteins	State Forest Ranger	604 Antelope Blvd.	Red Bluff 96080	916-527-2213	Box 1210
IV. South Sierra Headquarters	Gervise Nash	Chief	1234 East Shaw Avenue	Fresno 93710	209-222-3714	
	Don Petersen	Assistant Chief	1234 East Shaw Avenue	Fresno 93710	209-222-3714	
Amador-El Dorado Fresno-Kings Madra-Mariposa Tulare Tuolumne-Calaveras	Ralph Smith	State Forest Ranger	2840 Mt. Diablah Road	Camino 95709	916-644-2345	
	Carl Armstrong	State Forest Ranger	210 So. Academy Ave.	Sanger 95657	209-485-7500	
	John Morrow	State Forest Ranger	5366 N. Highway 49	Mariposa 95338	209-966-3622	
	Raymond H. Banks	State Forest Ranger	1968 S. Lovers Lane	Visalia 93277	209-732-5954	
	James Taylor	State Forest Ranger	785 El Dorado St.	San Andreas 95249	209-754-3831	Star Rt. 1
	John Hastings	Chief	2221 Garden Road	Monterey 93940	408-372-4536	
V. Central Coast Headquarters	Richard Bawcom	Assistant Chief	2221 Garden Road	Monterey 93940	408-372-4536	
	Thomas Perkins	State Forest Ranger	401 Canal Street	King City 93930	408-385-5412	
San Benito-Monterey San Luis Obispo San Mateo-Santa Cruz Santa Clara	Theodore Maddehl	State Forest Ranger	Morro Road	San Luis Obispo 93401	805-543-4244	Box 151
	Robert Voss	State Forest Ranger	6059 Highway 9	Felton 95018	408-335-5355	Drawer F-2
	Leroy Taylor	State Forest Ranger	15670 Monterey St.	Morgan Hill 95037	408-779-2121	
VI. Southern California Headquarters	Joseph C. Springer	Chief	2524 Mulberry Street	Riverside 92501	714-781-4140	Box 1067
	James Chambers	Assistant Chief	2524 Mulberry Street	Riverside 92501	714-781-4140	Box 1067
	Carl Downs	State Forest Ranger	180 S. Water Street	Orange 92666	714-538-3551	Box 86
	Ivan Phillips	State Forest Ranger	210 W. San Jacinto	Bishop 93514	714-387-2401	Rt. 2, Box 22L
	David Flake	State Forest Ranger	3800 Sierra Way	Perris 92370	714-657-3183	Box 248
San Bernardino San Diego	Rex Griggs	State Forest Ranger	2249 Jamacha Road	San Bernardino 92405	714-882-1227	
	James Dykes	State Forest Ranger	2249 Jamacha Road	El Cajon 92020	714-442-0874	
California Department of Forestry Fire Academy	James Simmons	State Forest Ranger		Yone 95640	209-274-2426	Rt. 1, Box 69

altitude below 6,000 feet MSL. The agency will then provide a special forecast 48-hours prior to the burn and daily thereafter as a special service.

Once again, the CDF will serve as a designated agency for permitting for most BLM lands in California. Other points of contact for BLM land managers include the CARB for burn/no-burn decisions for land areas at altitudes below 6,000 feet MSL. In addition, close contact must also be maintained with the NWS relative to fire weather forecasts such that all burning can be strictly controlled during dangerously dry periods. These are the key contacts. It is important to proceed with an attitude of cooperation with all agencies to insure safe outdoor burning as well as to limit the possible impacts on ambient air quality by the resultant smoke. BLM land managers will be required to keep a record of the amount of acreage and the tonnage of material burned daily as the APCD's will request this information in preparing their required quarterly reports to the CARB regarding burning permits.

Individual counties will prohibit such burning unless the appropriate permit from CDF or other designated agency has been obtained. In addition, the individual APCD's or county air pollution control officer may designate a particular day as a "burn day" or "no-burn day" dependent upon the meteorological conditions within his jurisdiction and time of year. Persons with the appropriate permits may commence their outdoor burning subject to the conditions of their permits on days designated "burn days".

6.6 GLOSSARY OF TERMS

Air Pollution Control District	In California, the county regulatory body responsible for the administration of air pollution regulations.
Air Quality Related Values	Under the Prevention of Significant Deterioration Regulations for Class I areas, the effect of potential pollutant emissions on such variables of soils, vegetation and, most importantly, visibility must be reviewed.
Attainment Areas	The term attainment area means for any air pollutant an area which is shown by monitored data or which is calculated by air quality modeling to comply with any National Ambient Air Quality Standard for such a pollutant.
Baseline Concentration	The ambient concentration level reflecting actual air quality as of August 7, 1977 minus any contribution from major stationary sources and major modifications on which construction commenced on or after January 6, 1975.
Best Available Control Technology (BACT)	An emission limitation (including a visible emissions standard) based on the maximum degree of reduction for each pollutant subject to regulation under the Act which would be emitted from any proposed major stationary source or major modification which the Administrator, on a case by case basis, taking into account energy, environmental and economic impacts and other costs determined to be achievable for such source or modification through application of production processes or available methods, systems and techniques including fuel cleaning or treatment or innovative fuel combustion techniques for control of such pollutant. BACT must always be at least as stringent as the Applicable New Source Performance Standard.
Best Available Retrofit Technology (BART)	Same as Best Available Control Technology with specific application to existing sources.
Burn Day	A burn day is any day on which a designated person or agency determines that certain specified burning is allowed.
Class Designation	The designation of the country as either Class I, II or III under the rules for the Prevention of Significant Deterioration. Class I

areas reflect the most stringent requirements while Class III areas are the most lenient.

Clean Air Act
(CAA)

The body of air quality legislation promulgated 1955 in with Amendments in 1963, 1965, 1967, 1970, and 1977, and codified in 42USC740/et seq., which are designed to regulate the nations air quality for the purpose of protecting human health and welfare.

Clean Air Act
Amendments
of 1977

They represent the latest in a series of expanding regulatory requirements designed to protect the air quality resource in the United States. The Amendments of 1977 (PL95-190) introduced key concepts including the Prevention of Significant Deterioration, the use of Best Available Control Technology and the protection of ambient visibility levels.

Criteria
Pollutants

That group of pollutants for which National Ambient Air Quality Standards have been promulgated based upon an analysis of the effects of such pollutants upon human health and welfare. Currently, SO₂, NO_x, CO, HC, TSP, lead and photochemical oxidants are criteria pollutants.

Designated
Agency

The governmental agency with final authority relative to air quality regulations.

Federal Land
Manager

Federal Land Manager means with respect to any lands in the United States, the Secretary of the Department with authority over such lands.

Increments

The maximum allowable increase in a specific pollutant concentration over and above existing "baseline concentrations" as specified in Section 163 of the CAA or as limited by the difference between Air Quality Standards and baseline concentrations for that pollutant.

Indian
Governing Body

The term means the governing body of any tribe, band or group of Indians subject to the jurisdiction of the United States and recognized by the United States as possessing power of self government.

Lowest Achievable
Emission Rate
(LAER)

The emission control technology applicable to source located in a nonattainment area is established based upon the term Lowest Achievable Emission Rate. This term means that level of emissions which reflects the most stringent emission limitation that is contained in the Implementation Plan of any state

or the most stringent emission limitation which is achieved in practice on such class or category of source which ever is more stringent.

Mandatory Class I Area	The term means Federal areas which may not be designated as other than Class I areas under the Clean Air Act Amendments of 1977. These areas are specified in Section 162(a) of the Act.
Modification	Any physical change in the method of operation or an addition to a stationary source, which increases the potential emission rate of any pollutant regulated under the Act by either 100 tons/year or more for any source category identified by the New Source Performance Standards or by 250 tons/year or more for any stationary source.
National Ambient Air Quality Standards (NAAQS)	The Clean Air Act Amendments of 1970 required that specific pollutant concentration levels be identified for the protection of human health (i.e., Primary Standard) and welfare (i.e., Secondary Standards) for each of the criteria pollutants. These specific pollutant levels comprise the National Ambient Air Quality Standards.
National Emissions Standards for Hazardous Air Pollutants (NESHAPS)	Standards promulgated for air pollutants for which no ambient air quality standard is applicable and which in the judgement of the Administrator cause or contribute to air pollution which may reasonably be anticipated to result in an increase in mortality or an increase in serious irreversible or incapacitating reversible illness.
New Source	Any new structure, building, facility, equipment, installation or operation which is located on one or more continuous or adjacent properties and which is owned or operated by the same person.
New Source Performance Standards (NSPS)	National Standards promulgated by the USEPA which set emissions limitations for standards of performance for each of 28 separate categories of stationary sources.
New Source Review	No major emitting facility on which construction is commenced after the date of the enactment of the Clean Air Act Amendments of 1977 may be constructed in any area unless the formal permit application process has been

	completed in accordance with regulations required by Section 165 of the Clean Air Act Amendments of 1977.
No Burn Day	A no burn day is any day on which a designated person or agency determines that certain specified burning is not permitted.
Nonattainment Areas	The term nonattainment area means, for any air pollutant, an area which is showed by monitored data or, which is calculated by air quality modeling, to exceed any National Ambient Air Quality Standard for such pollutant.
Offsets	Sources locating in nonattainment areas, must obtain emission reductions from other existing sources in the region that more than offset the increase in emissions from the new source. Such offsets must produce a positive net air quality benefit resulting in reasonable further progress toward attainment of the applicable standard.
Permit Moratorium	The cessation of the air quality permitting process pending the resolution of mandatory regulatory activity.
Potential Emissions	Potential Emissions refer to the maximum emission of pollutants in the absence of air pollutant control equipment.
Pre-Construction Review	No major emitting facility on which construction is commenced after the date of the enactment of the Clean Air Act Amendments of 1977 may be constructed in any area unless the formal permit application process has been completed in accordance with regulations required by Section 165 of the Clean Air Act Amendments of 1977.
Prevention of Significant Deterioration	Specific requirements contained in the Clean Air Act Amendments of 1977 (i.e. Part C, Sections 160 through 169) designed to protect the air quality resource in regions of the country where present baseline pollutant levels are below the National Ambient Air Quality Standards.
Primary Standards	Standards promulgated as part of the National Ambient Air Quality Standards which set pollutant levels which provide an adequate margin of safety for public health.

Reasonably Available Control Technology (RACT)	The least stringent in the control technology heirarchy applicable to existing sources which require a level of control necessary to insure compliance with existing emissions regulations.
Retrofitting	The installation of additional control technology on existing sources of air pollutants.
Secondary Standards	Standards promulgated as part of the National Ambient Air Quality Standards which specify levels which protect the human welfare from known or anticipated adverse effects associated with a pollutants presence in the ambient air.
State Implementation (SIP)	The concept of State Implementation Plans was introduced in the 1970 Clean Air Act AmendPlan ments. There purpose is to insure that the NAAQS are met in all areas of the country and require a transportation control plan, emissions limits for specific categories for sources and permit rules for new or modified sources of pollutants.

BIBLIOGRAPHY

The Clean Air Act (42 U.S.C. 1857 et seq.)

Easton, E.B. and F.J. O'Donnel, "The Clean Air Act Amendments of 1977." Journal of Air Pollution Control Association, Vol. 27, No. 10, October 1977, p. 943-947.

Goldsmith, B.J. and R.J. Mahoney, "Implications of the 1977 Clean Air Act Amendments for Stationary Sources", Environmental Science and Technology, Vol. 12, No. 2, Feb. 1976, p. 144-149.

High, M.D. "Status Report on Federal Regulations for New Source Performance Standards". Journal of Air Pollution Control Association, Vol. 26, No. 5 May 1976, p. 471--479.

Ninety-Fifth Congress, "Clean Air Act Amendments of 1977" (Public Law 95-95; 91 STAT. 685), August 7, 1977.

Plumas County Air Pollution Control District, Rules & Regulations, Quincy, CA, December 12, 1976.

Stern, A.C. "Prevention of Significant Deterioration - A Critical Review", Journal of Air Pollution Control Association, Vol. 27, No. 5, May 1977, p. 440-453.

7. MONITORING RECOMMENDATIONS

7.1 GENERAL REQUIREMENTS

Possible alternatives for future land development of BLM lands within the Susanville District may require the preparation of extensive environmental research reports and impact analyses. In light of this fact, it is important to isolate areas currently under BLM administration that lack substantial onsite data necessary for the preparation of air quality and meteorological analyses. Additionally, areas within the Susanville District that require enhancement of the current existing data base must be identified so that transport and diffusion analyses can be accurately performed.

The ultimate objective is to be able to define air transport and dispersion characteristics and associated baseline ambient air quality levels within the Susanville District. An accurate and current data base provides the means to achieve this objective and enhances credibility of regional environmental impact statements. It is of vital importance to all organizations concerned with future land development within the Susanville District, that the most accurate and complete environmental impact statements be developed.

A review of the previous sections describing regional air quality, dispersion meteorology and baseline climatology for the Susanville District indicates that certain areas lack the satisfactory historical data base necessary to provide a definitive characterization of these topical items which are essential in environmental analyses. Climatological data are generally adequate for all portions of the Susanville District. Ambient air quality data are generally not available in sufficient detail to provide a good understanding of pollutant baseline levels. Detailed dispersion meteorological data are available at a few select locations near the District and represent the least resolved data base of all the major air quality components. Data are available to provide an assessment of regional dispersion for most of the Susanville District; however, the extent of the current data base available for site-specific dispersion analyses on lands under BLM administration is generally not satisfactory.

Lands within the Susanville District currently under BLM jurisdiction entail one basic geographical area. As depicted in Figure 7.1-1, the BLM lands in the Susanville District are located east of the Cascade and Sierra Nevada Ranges.

Alternative future land uses for these areas may include construction or expansion of energy related facilities, other commercial industrialization, recreation, agriculture, forestry and many others. The development of BLM administered lands for these alternatives may require extensive and elaborate environmental impact assessments including air quality, dispersion meteorology and climatology. The most accurate environmental

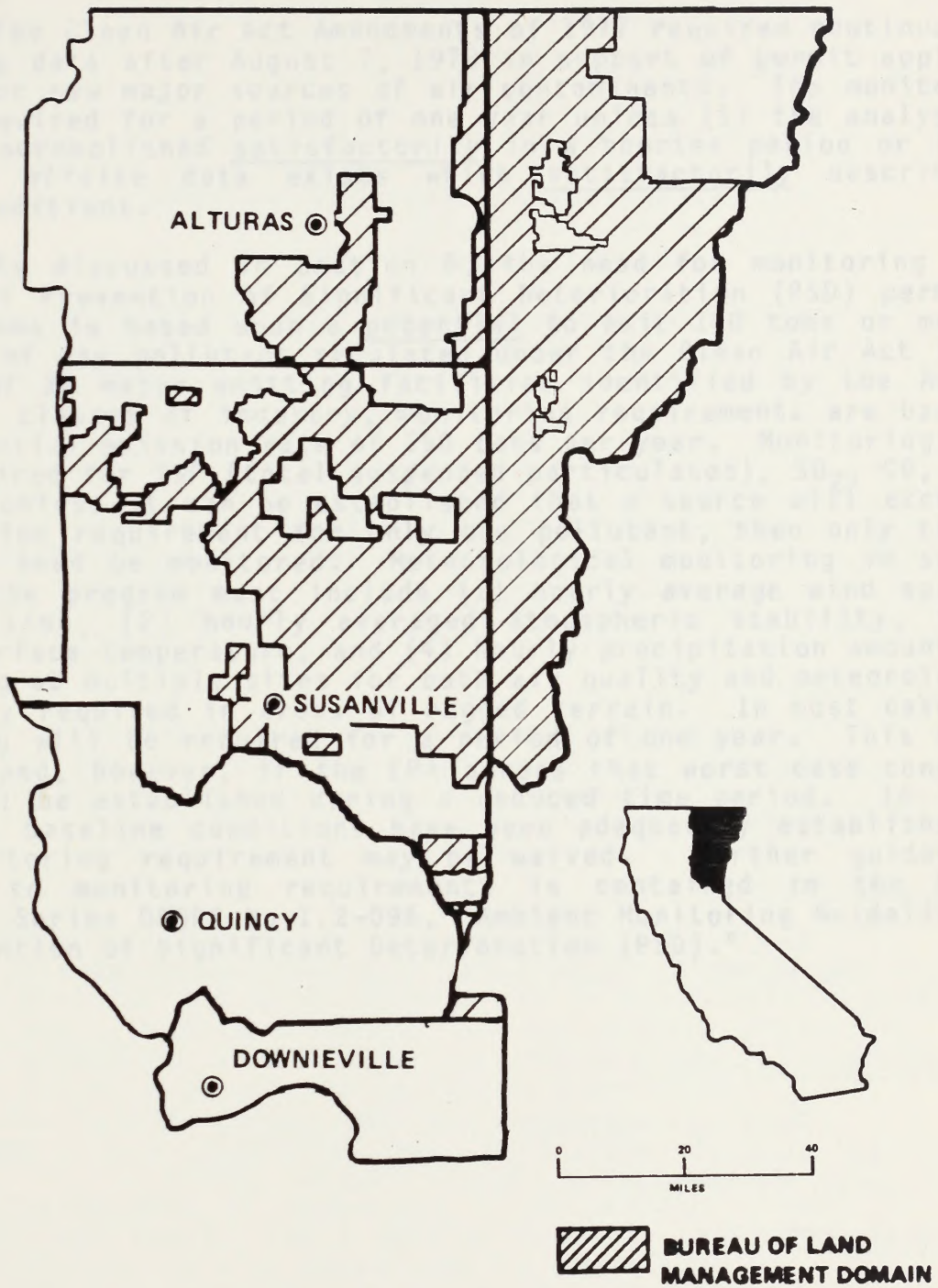

Figure 7.1-1
BLM Lands in the Susanville District

impact assessment is derived from a highly detailed site-specific data base. Hence, the adequacy of the air quality data base for specific areas of concern must be identified.

The Clean Air Act Amendments of 1977 required continuous monitoring data after August 7, 1978 in support of permit applications for new major sources of air contaminants. The monitoring is required for a period of one year unless (1) the analysis could be accomplished satisfactorily in a shorter period or (2) available offsite data exists which satisfactorily describes onsite conditions.

As discussed in Section 6, the need for monitoring in support of Prevention of Significant Deterioration (PSD) permit applications is based upon a potential to emit 100 tons or more per year of any pollutant regulated under the Clean Air Act for any one of 28 major emitting facilities identified by the Act. For other classes of industry, monitoring requirements are based on a potential emission rate of 250 tons per year. Monitoring is then required for TSP (total suspended particulates), SO₂, CO, O₃ and NO₂, unless it can be established that a source will exceed the emission requirement for only one pollutant, then only that pollutant need be monitored. Meteorological monitoring in support of the program must include (1) hourly average wind speed and direction, (2) hourly averaged atmospheric stability, (3) hourly surface temperature, and (4) hourly precipitation amounts. Monitoring at multiple sites for both air quality and meteorology is usually required in areas of rugged terrain. In most cases, monitoring will be required for a period of one year. This may be shortened, however, if the EPA agrees that worst case conditions will be established during a reduced time period. In the case that baseline conditions have been adequately established, this monitoring requirement may be waived. Further guidance relative to monitoring requirements is contained in the EPA Guideline Series OAQPS No 1.2-096, "Ambient Monitoring Guidelines for Prevention of Significant Deterioration (PSD)."

7.2 INSTRUMENTATION

This section provides a brief review of instrumentation that is commonly used to monitor the various air quality and meteorological parameters. A summary of costs associated with the management and operation of monitoring programs is also provided.

7.2.1 General Requirements

The purchase of an instrument requires the consideration of two classes of requirements:

1. General Instrumentation
2. Specific Objectives

There are many instrumentation requirements that will obviously depend on the specific objectives of the study for which the instrument is needed. There are, however, a number of instrument requirements that should be considered before the purchase of any instrument. The purpose of this section is to describe these general requirements so that a buyer will be able to distinguish between the instrumentation attributes that are important, and those that are only "window dressing". The EPA may be contacted for further guidance on instrumentation and methods of procedure.

Reliability

Reliability is possibly the most important criterion for an instrument in continuous use. Regardless of how accurately an instrument is calibrated and read, it must be reliable to give reproducible results.

Quality Control

Quality control are those activities performed to insure that equipment is maintained and calibrated within specifications.

Quality Assurance

Quality assurance is the method which verifies that quality control activities are performed, e.g., adherence to schedule, documentation, double checks, etc.

Accuracy

Accuracy is defined as the closeness of the instrument output reading to the true value of the parameter. The qualifications of an accurate instrument are as follows:

1. It is properly calibrated under known conditions
2. It has characteristics that are unchanging with time

3. The reactions of the instrument (dynamic response) to changes in the measured parameter are known to within the limits of error requirements.

Precision

Precision is generally defined as the degree of closeness of a series of readings of an unchanging parameter. There often is confusion between the terms accuracy and precision. One way of clarifying their meanings is through the use of the "bulls eye" analogy. Figure 7.2-1 depicts this analogy.

Sensitivity

Sensitivity is defined as the smallest change in the measured variable that causes a detectable change in the output of the instrument.

Simplicity

The lack of instrumentation experience among most observers makes this attribute a must for most meteorological and air quality instrumentation. The qualifications of a simple instrument are as follows:

1. Operational adjustments of the instrument should be simple
2. A simply written Standard Operating Procedures (SOP) manual should accompany the instrument
3. Adjustments that are not intended to be made by the purchaser should require a special tool.

Durability

Obviously, an instrument should be durable enough to survive vibrations and shock encountered in transportation, rough handling, etc. A meteorological or air quality instrument, in addition, should be able to perform reliably in all seasons of the year, and in a smoggy and corrosive atmosphere.

Convenience

Convenience of operation is definitely a must for an operational instrument. As a general rule, an instrument that is simple to operate is also convenient to operate.

Other requirements such as time constants, damping ratio, etc. are objective oriented, and will be covered in a later section.

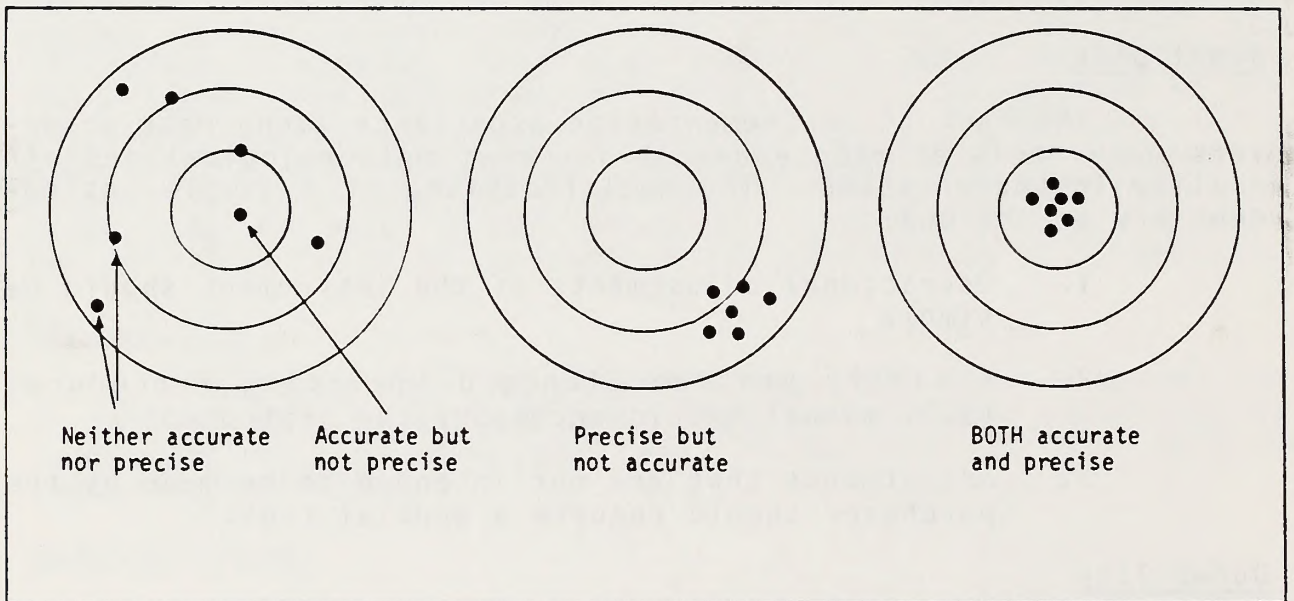

Figure 7.2-1
 The Relationship Between
 Instrument Accuracy and Precision .

7.2.2 Meteorological Instruments

Measurement of atmospheric variables that affect the diffusion and transport of air pollutants is a necessity in nearly every air pollution investigation. Suitable measurements may be available from existing instrumentation at Weather Service city offices, airport stations, or from universities or industries with meteorological installations. Frequently, however, existing instrumentation does not give detailed enough measurements, is not representative of the area in question, or does not measure the variables desired (such as turbulence) and additional instruments must be operated.

Of primary importance in air pollution meteorology is the measurement of wind, including both velocity (direction and speed) and the turbulence. The stability of the lower layers of the atmosphere in which the pollution diffuses is important and may be determined from an analysis of the turbulence characteristics of the atmosphere or the temperature lapse rate.

Of secondary importance is the measurement of humidity (which may affect atmospheric reactions), temperature, precipitation (of importance in washout of pollutants), and solar radiation (which affects photochemical reactions in the atmosphere). Particularly for research studies, it may also be desirable to measure meteorological elements affected by pollutants, such as visibility, solar radiation, and illumination (radiation in the visible range).

Wind Measurements - Surface Instrumentation

- Wind Speed

Generally, wind speed sensors are broken down into the following categories:

- a. Rotational Anemometers
 - 1) Vertical Shaft
 - 2) Horizontal Shaft
- b. Pressure Anemometers
 - 1) Flat Plate Type Anemometer
 - 2) Tube Type Anemometer
- c. Bridled Cup Anemometer
- d. Special Types
 - 1) Hot Wire Anemometer
 - 2) Sonic Anemometer
 - 3) Bivane
 - 4) Vertical/Horizontal (UVW) Anemometer

Pressure anemometers, hot wire and sonic anemometers have enjoyed extensive use in research type operations, but they

all have disadvantages which have prohibited their use in operational type situations, such as air pollution surveys. The rotational type anemometers are the most common type of wind speed sensor in use today mainly because they are the only types that satisfy all of the following desirable operational features:

- a. Essentially linear relationship between the sensor output and the wind speed;
- b. Calibration unaffected by changes in atmospheric temperature, pressure or humidity;
- c. Able to measure a wide range of wind speeds (<2 to 200 mph [.9 to 90 m/s]).
- d. Long term calibration stability, or calibrations that remain unchanged after 10 years continuous operation;
- e. Output of the sensor easily adapted to remote indication;
- f. Recording of the wind speed data easily adaptable to either analog or digital form; and
- g. Generally an extremely small maintenance requirement.

Figure 7.2-2 provides a visual review of routinely available anemometers.

- Wind Direction

Wind direction sensors are visually presented in Figure 7.2-3 (a-p). They include; (1) flat plate vanes (a, b, c, d, g, i, k, l), (2) splayed vanes (e, f, h, p) and (3) aerodynamic shaped vanes (j, m, n, o).

The splayed vane of Figure 7.2-3 has, mainly because of its durability and reliability, found widespread use in its role as the main wind direction sensor for the National Weather Service. It should be noted that wind direction data obtained from the National Weather Service should be used only as an indication of average wind direction.

A bi-directional vane is designed to rotate around a vertical axis to measure the azimuth angle of the wind, as does a conventional wind vane. It also can move in the vertical to measure the elevation angle of the wind. Because the vertical motions of the atmosphere are frequently of a different character than the horizontal motions (anisotropic turbulence), measurement of both the horizontal and vertical motions are desirable. This is particularly true under stable conditions when the



Climet Inst. Co. (a)



R.M. Young Co. (b)

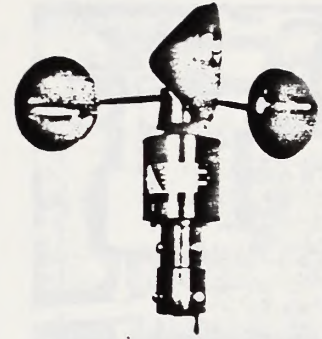

Belfort Inst. Co. (c)



Henry J. Green Co. (d)



Electric Speed Indicator Co. (e)

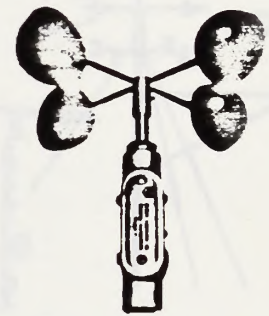

Science Associates Inc. (f)

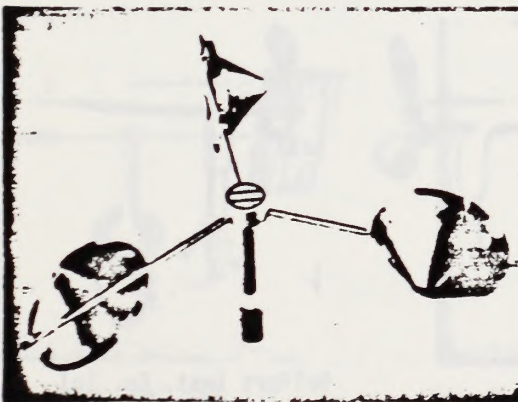

Teledyne-Geotech (Bkmm & Whtly) (g)



Teledyne-Geotech (Bkmm & Whtly) (h)

Figure 7.2-2
Cup Anemometers

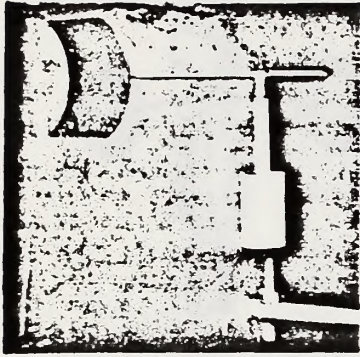

Climet Inst. Co. (a)

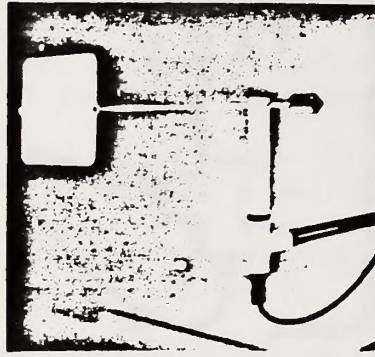

R.M. Young Co. (b)



Belfort Inst. Co. (c)

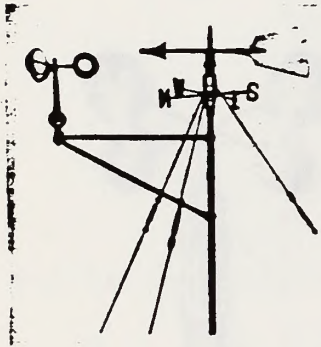

Science Associates Inc. (g)



Epic Co. (h)

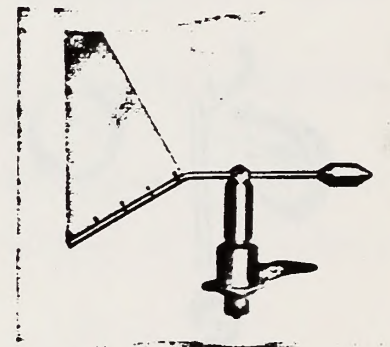

Epic Co. (i)



Teledyne-Geotech (l)



Bendix Co. (m)



Belfort Inst. Co. (n)

Figure 7.2-3
Wind Vanes



Wong Lab. (d)

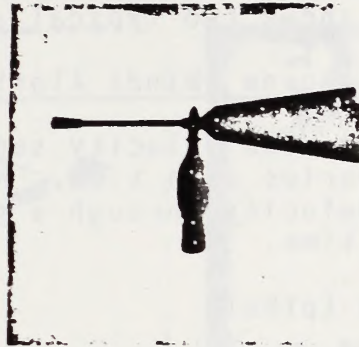

Electric Speed Indicator Co. (e)

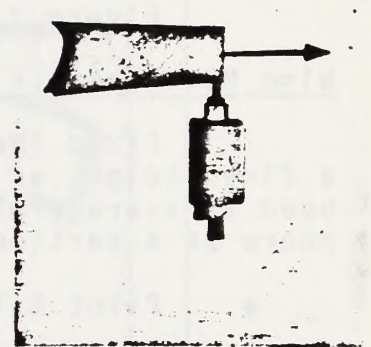

Science Associates Inc. (f)



Teledyne-Geotech (j)

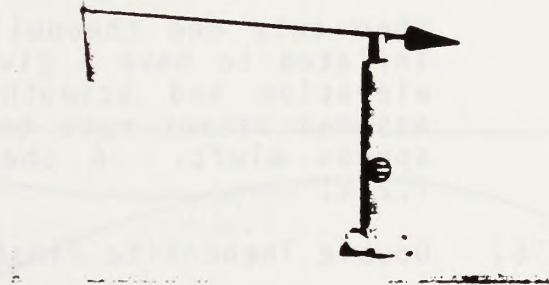

Teledyne-Geotech (k)



Raim Inst. Co. (o)



Epic Co. (p)

Figure 7.2-3 (Cont.)
Wind Vanes

vertical motion is almost absent, but horizontal changes in wind direction may be appreciable. Micro-potentiometers are usually used to produce an analog record of both angles. The total wind speed can be measured by replacing the counterweight with a propeller anemometer. Figure 7.2-4 shows two typical anemometer bivanes.

Wind Measurements - Airborne (Winds Aloft)

Fixed location wind velocity sensors measure the wind at a fixed height as it varies with time. Most airborne sensors are used to average wind velocity through a given depth of the atmosphere at a particular time.

- Pilot Balloon (pibal)

This method of measuring wind velocity uses a gas-filled free balloon (Figure 7.2-5) which is tracked visually through a theodolite. The theodolite is an optical system used to measure the azimuth and elevation angle of the balloon.

- a. Single Theodolite Pibals

When only one theodolite is used, the balloon is inflated to have a given amount of free lift. The elevation and azimuth angles are used with the assumed ascent rate to compute wind directions and speeds aloft. A theodolite is shown in Figure 7.2-6.

- b. Double Theodolite Pibals

By this method, the ascent rate of the balloon is not assumed, but calculated from the elevation and azimuth angles of the two theodolite observations taken simultaneously. The two theodolites are set a known distance apart (the baseline). Two types of pilot balloons frequently used reach 3000 ft. within 5 minutes and 8 minutes, respectively, after release. If detailed structure of winds with height is to be determined, readings of azimuth and elevation angle must be read every 15 or 30 seconds.

- Rawinsonde

This method of measuring wind velocity aloft also uses a gas-filled free balloon, but it is tracked either by radio direction finding apparatus, or by radar. The former method is that most frequently used in the U.S. The radio transmitter carried by the free balloon is usually used to transmit pressure, temperature and humidity information to the ground (radiosonde). The

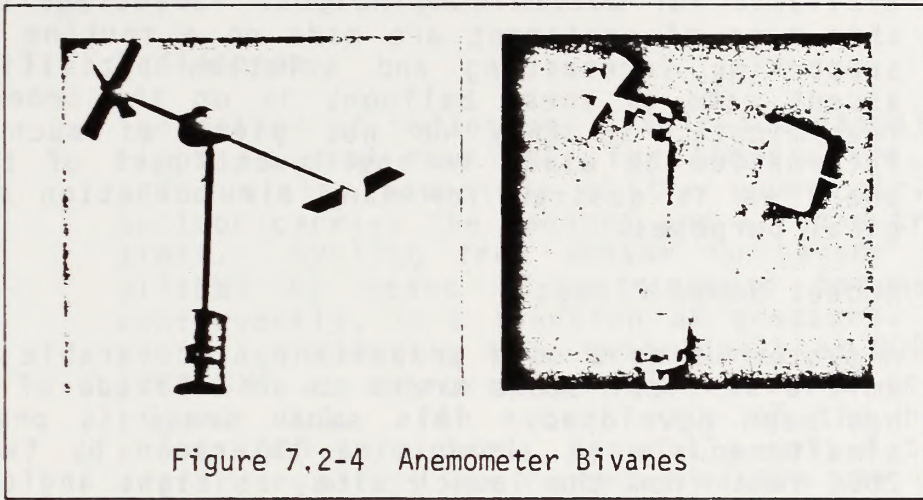

Figure 7.2-4 Anemometer Bivanes

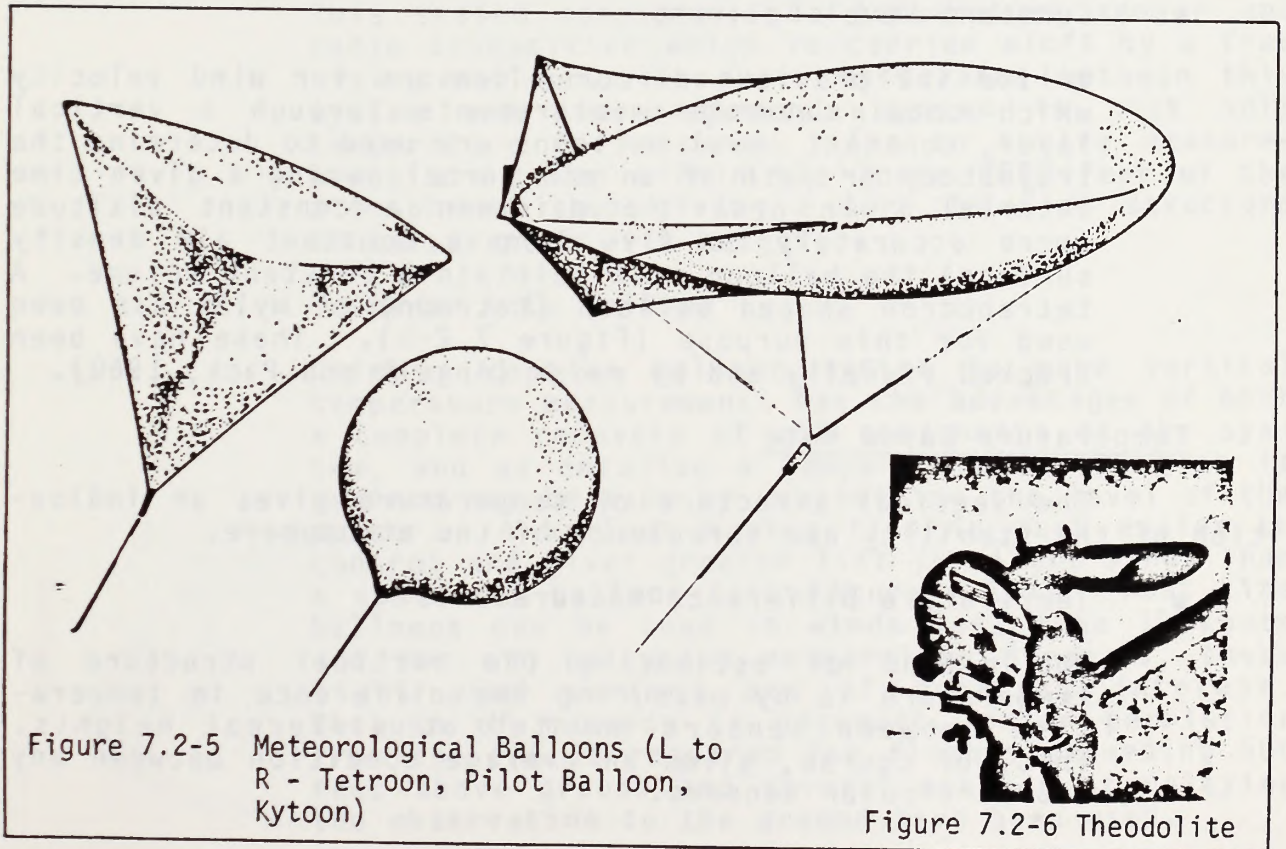

Figure 7.2-5 Meteorological Balloons (L to R - Tetraon, Pilot Balloon, Kytoon)

Figure 7.2-6 Theodolite

radio direction finding equipment determines the elevation angles and azimuth angles of the transmitter. The height is determined by evaluation of the temperature pressure sounding. Using radar, the slant range is available for determining height. Soundings taken with this type of equipment are made on a routine basis for supporting forecasting and aviation activities. The ascent rate of these balloons is on the order of 1000 feet/minute, so they do not yield as much detailed information on winds in the lowest part of the atmosphere as is desired for many air pollution meteorological purposes.

- Rocket Smoke Plumes

A system using a cold propellant, recoverable rocket to emit a vertical smoke trail to an altitude of 1200 feet has been developed. This smoke trail is photographed simultaneously at short time intervals by two cameras 2000 feet from the launch site, at right angles to each other. The difference in position of the smoke trail from two successive photographs is a measure of one component (north-south for example) of the wind and can be determined at any number of heights from ground level to 1200 feet. Another similar system has been reported by Cooke (1962).

- Constant Level Balloons

Unlike the previous airborne sensors for wind velocity which obtain average measurements through a vertical layer, constant level balloons are used to determine the trajectory or path of an air parcel during a given time interval. In order to maintain a constant altitude (more accurately to fly along a constant air density surface) the balloon must maintain a constant volume. A tetrahedron shaped balloon (tetroon) of mylar has been used for this purpose (Figure 7.2-5). These have been tracked visually and by radar (Angell and Pack, 1960).

Temperature Lapse Rate

The vertical structure of temperature gives an indication of the stability and turbulence of the atmosphere.

- Temperature Difference Measurements

One method of estimating the vertical structure of temperature is by measuring the difference in temperature between sensors mounted at different heights. This, of course, gives an average condition between any two particular sensors.

- Balloon-borne Sensors

Temperature sensors may be lifted by either free or captive balloons. By these methods, temperature, not temperature difference, is measured.

1. Radiosonde

The method of radiosonde (radio-soundings) observations is used routinely for temperature, pressure and humidity soundings of the upper air. A free balloon carries the sensors and a radio transmitter aloft. Cycling from sensor to sensor is accomplished by means of an aneroid barometer, and consequently, is a function of pressure. Observations are normally made twice daily at 0000 GMT and 1200 GMT at approximately 70 stations in the contiguous U.S. The ascent rate of the balloon is about 1000 ft/minute. Generally only 4 to 6 temperature readings are recorded within the lower 3000 feet, so the vertical temperature information is not too detailed, but it is still of considerable use when more detailed information is not available.

2. T-Sonde

This system consists of a temperature sensor and radio transmitter which is carried aloft by a free rising balloon. The main difference between this system and the radiosonde system is that only temperature is measured. Ten to twelve measurements are taken within the lower 3000 feet of the atmosphere, thus giving a more detailed structure of temperature with height.

3. Tethered Kite Balloon

Using a captive balloon system to make vertical temperature measurements has the advantages of both a complete recovery of all components of the system, and as detailed a temperature sounding as is desired may be made by controlling the level of the sensor. A balloon having fins is much easier to control and gives greater lift in slight winds than a spherical balloon (see Figure 7.2-5). Most kite balloons can be used in winds less than 15 knots and for air pollution meteorology purposes, these light wind periods are of greatest interest. Because of hazards to aircraft, prior permission from the FAA is required for flights exceeding 500 feet above ground and several methods of relaying the observation to the ground have been used.

- Aircraft Borne Sensors

In some cases, light aircraft or helicopters have been used for obtaining temperature lapse rate measurements. Although there are complete systems commercially available for this method of temperature lapse rate measurement, one can use standard temperature sensors (thermistors, resistance thermometers, etc.) and recorders, as long as exposure guidelines are followed.

Precipitation

Because large particles and water soluble gases may be removed from the atmosphere by falling precipitation, measurements of this element may be needed. Chemical or radioactive analysis of rainwater may also be desired.

- Standard Rain Gauge

The standard rain gauge consists of a metal funnel 8 inches in diameter, a measuring tube having 1/10 the cross-sectional area of the funnel, and a large container 8 inches in diameter (Figure 7.2-7). Normally, precipitation is funneled into the measuring tube and the depth of water in the tube is measured using a dip stick having a special scale (because of the reduction in area). Measurements with this instrument, because they are made manually, yield only accumulated amount since the last measurement.

Humidity

Because of its influence upon certain chemical reactions in the atmosphere and its influence upon visibility, it may be desirable to measure humidity in connection with an air pollution investigation. Also, some air pollutants affect receptors differently with different humidities, so measurement may be important in this respect.

- Hygrothermograph

This instrument measures both temperature and humidity by activating pen arms to give a continuous record of each element on a strip chart. The chart generally can be used for 7 days. The humidity sensor generally uses human hairs which lengthen as relative humidity increases and shorten with humidity decreases. Temperature measurements are usually made with a bourdon tube which is a curved metal tube containing an organic liquid. The system changes curvature with changes in temperature, activating the pen arm. A hygrothermograph is shown in Figure 7.2-8.

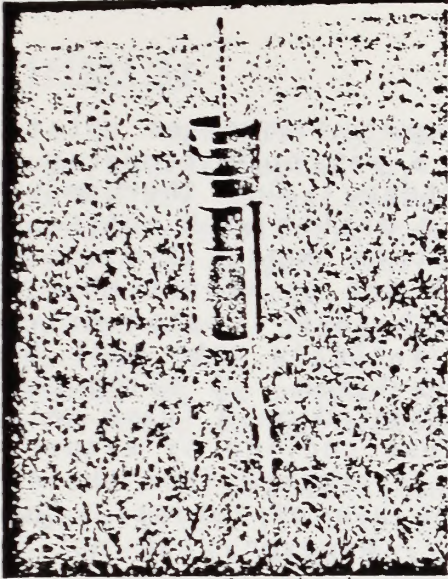

Figure 7.2-7 - Standard Rain Gauge

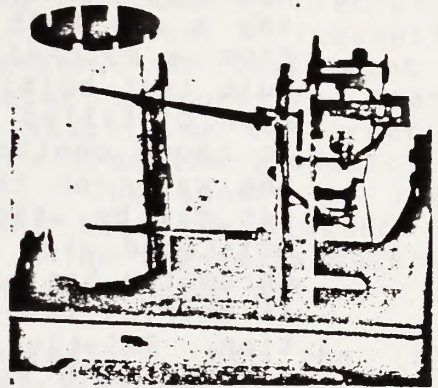

Figure 7.2-8 - Hygrothermograph

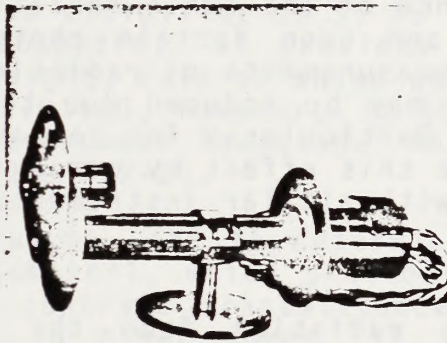

Figure 7.2-10 - Pyrheliometer

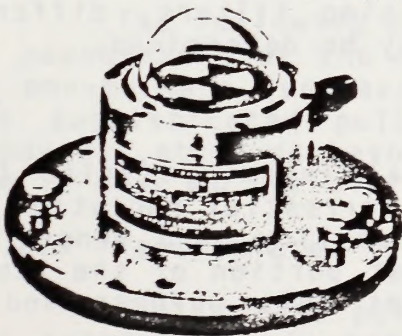

Figure 7.2-9
"Black and White" Pyranometer



Figure 7.2-11 - Equatorial Mount

- Psychrometers

Humidity measurement by a psychrometer involves obtaining a dry bulb temperature and a wet bulb temperature from a matched set of thermometers. One thermometer bulb (wet bulb) is covered with a muslin wick moistened with distilled water. There must be enough air motion to cause cooling of the wet bulb due to evaporation of the water on the wick. To obtain this a motor driven fan may be used to draw air at a steady rate past the moistened wick while a reading is taken. A sling psychrometer has both thermometers mounted on a frame which is whirled through the air to cause cooling by evaporation. Relative humidity is then determined from the dry and wet bulb readings through the use of tables. Continuous measurements of humidity, however, can not be obtained using psychrometers.

Radiation

The influence of the sun's radiation upon the turbulence of the atmosphere and upon certain photochemical reactions is sufficient to make measurements of radiation quite important. In addition, radiation may be reduced due to particulate pollution in the atmosphere. Particularly for research purposes, it may be desirable to measure this effect by comparisons between urban and non-urban stations with similar instruments.

- Total Radiation

The direct radiation from the sun plus the diffuse radiation from the sky may be measured by pyranometers. These instruments are mounted so that the sensor is horizontal and can receive the radiation throughout the hemisphere defined by the horizon. The instrument illustrated in Figure 7.2-9 is of this type.

- Direct Solar Radiation

The direct solar radiation may be measured continuously by using the pyrheliometer shown in Figure 7.2-10 mounted upon an equatorial mount (Figure 7.2-11) to keep it pointed toward the sun. By using filters, different spectral regions of radiation may be determined.

- Net Radiation

The difference between the total incoming (solar plus sky) radiation and the outgoing terrestrial radiation may be useful in determining the stability, and hence, the turbulent character of the lowest portion of the atmosphere. A net radiometer serves this purpose and is shown in Figure 7.2-12.

Visibility

Visibility, in addition to being affected by precipitation, is affected by humidity and air pollution. Frequently, visibility is estimated by a human observer. An instrument to measure visibility, called a transmissometer, measures the transmission of light over a fixed baseline, usually on the order of 500 to 700 feet. An intense light source from the projector is focused on a photocell in the detector. The amount of light reaching the photocell over the constant baseline distance is assumed to be proportional to visibility. The transmissometer is restricted to estimating visibility in one direction only.

A transmissometer is also limited in that the light transmission it detects is affected mainly by liquid droplets in the air. It does not detect, to any great efficiency, the particulate matter in the atmosphere. The projector is shown in Figure 7.2-13 and the detector in Figure 7.2-14. A relatively new instrument, called a nephelometer, has been developed which measures the amount of light scattered by impurities, (mainly dust) and thus indicates visibility as it is affected by particulate matter in the atmosphere. It provides for continuous output, operating day or night, rain or shine and is relatively easy to calibrate. It is limited, however, in that measurements may be taken only at the instrument location. An integrating nephelometer is shown in Figure 7.2-15.

Another instrument used to determine visibility is the Vista Ranger (telephotometer), which provides radiance values of a target and the sky, contrast transmittance and data regarding target chromaticity. In other words, it is a telescope type instrument which looks at the sky and a target (such as a mountain peak) and measures the brightness contrast between the two and transmits information on the true color of what is seen. Measurements can be made over long path lengths (tens of Km) and provide quantitative and continuous output. The Vista Ranger, however, can be used only during daytime and readings are more accurate during times of higher sun angle and relatively clear skies.

7.2.3 Air Quality Instruments

The following paragraphs discuss sampling techniques for the measurement of the criteria pollutants TSP, SO₂, NO₂, CO, O₃ and non-methane (unreactive) hydrocarbons (NMHC).² Sampling for more sophisticated pollutant species (e.g., sulfates, organic compounds, etc.) is beyond the realm of the discussion and reference is made to the bibliography for a more detailed discussion.

7.2.3.1 Particulates

Particulate pollutants are divided generally into dust that settles in air and dust that remains suspended as an aerosol. The physical consideration determining the class into which a particle falls is the particle diameter.

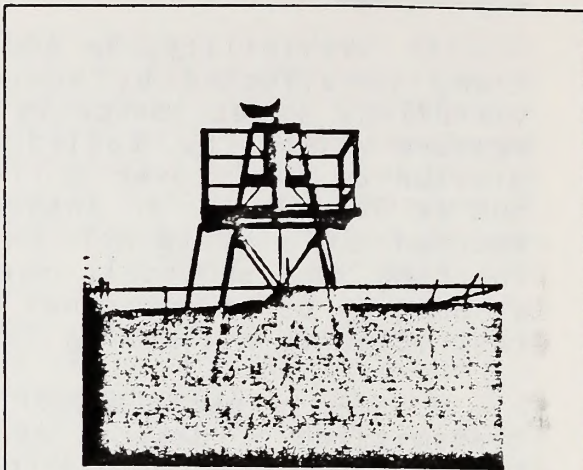
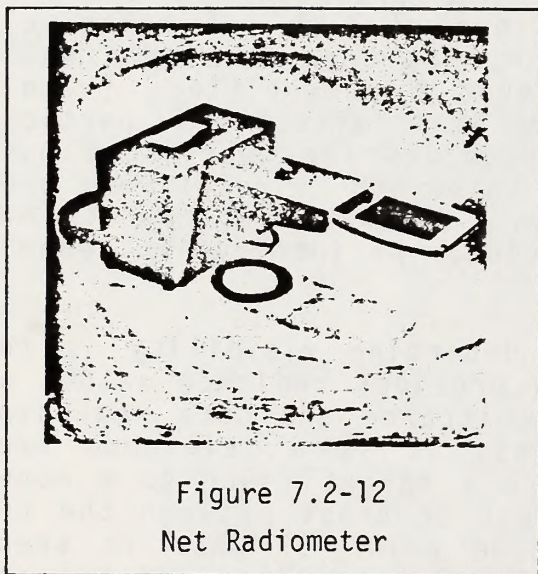

Figure 7.2-13
Transmissometer Detector

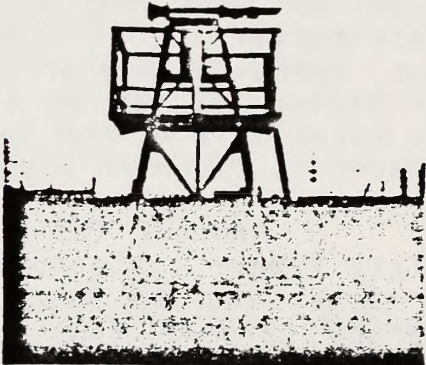

Figure 7.2-14
Transmissometer Receiver

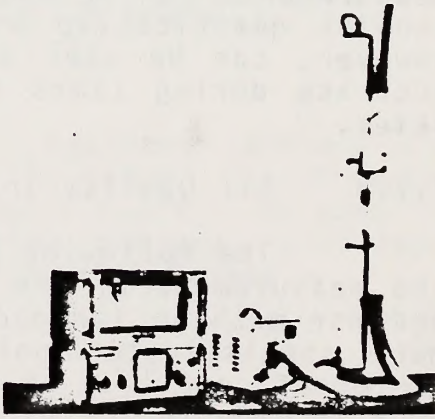

Figure 7.2-15
Integrating Nephelometer

As a matter of working definition, particles larger than 10 inch diameter are usually thought of as "settleable" while those of a smaller diameter are referred to as "suspended".

Instruments designed to collect either class of particulates are ordinarily chemically passive physical collectors whose function is merely to permit measurement of the collected material without regard to the composition. Generally, the particulates encountered include various mineral dusts (i.e. metallic oxides, sand, carbon particles, flyash fibers and pollen). These particulates can be collected using equipment based on one or more of the following principles.

Dust Sampling by Gravity Settling (Dustfall)

Particles generally larger than 10 in diameter, which are known to settle from air and collect on horizontal surfaces, can be sampled merely by placing an open container in an outdoor area that is free from overhead obstructions. These collectors are ordinarily constructed of polyethylene, glass, or stainless steel, since the inside walls must be inert to atmospheric oxidative flaking, which would contribute to sample weight. In addition, identical dustfall containers should be employed in the same sampling network or where a comparison of results will be made. Figure 7.2-16 presents a simple dustfall collector.

In sampling rather large areas, such as entire communities, it is common to employ at least one dustfall container for every 10 square miles. On the other hand, when dustfall sampling is intended to measure the effect of a given industry or industrial complex, containers may be placed as close as a few hundred feet apart.

This basic working principal is the foundation for the atmospheric deposition station located in the Ukiah District. There are 40 to 60 similar stations nationwide measuring the following elements: SO_4^{2-} , NO_3^- , PO_4^{3-} , CO, NH_4^+ , K^+ , Na^+ , Ca^{++} , Mg^{++} , and pH including total and free acidity and alkalinity and electrical conductivity. The objectives of this program are to measure atmospheric deposition, through precipitation and particulate settling, identifying spatial and temporal trends, to evaluate the importance of natural phenomena (volcanos, soil erosion, etc.) and human activities (power plants, industrial emissions, etc.) as they contribute to the total atmospheric deposition and finally, to research the effect these elements will have on activities such as agricultural, forest, range, fisheries and wildlife management.

Dust Sampling by High-Volume Filtration (The High Volume Sampler)

The high-volume (hi-vol) sampler (see Figure 7.2-17) employs the sloping roof of the shelter as a means for causing air entering the sampler under the eaves of the roof to change direction at least 90° before entering the horizontal filter.

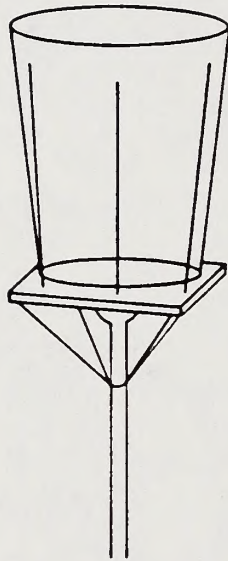

Figure 7.2-16
Simple Dustfall Collector

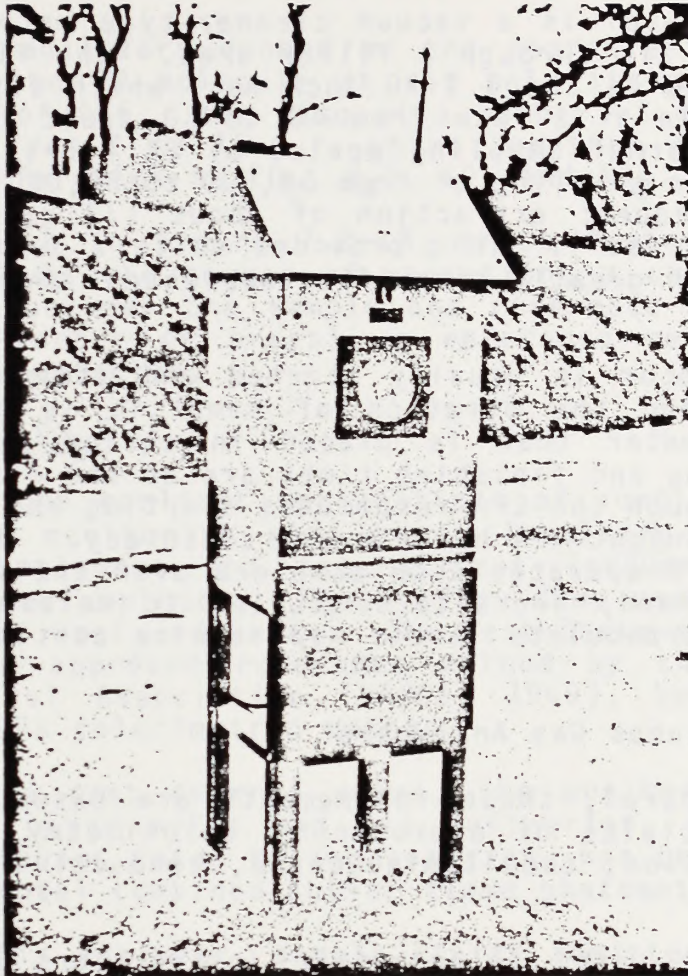

Figure 7.2-17
High Volume (hi-vol) Air Sampler

Particles that remain entrained in the air sample prior to horizontal filtration have, in so doing, satisfied the definition of truly suspended dust or dust that is not subject to settling under the influence of gravitational force.

The hi-vol is a vacuum cleaner-type motor that is used to draw sample air through a filter area. The filter most frequently employed is the 8 X 10 inch mat, which allows collection of an air sample at a rate from 40 to 60 cubic feet per minute (cfm) over a normal sampling period of 24 hours. These conditions permit the sampling of from 58,000 to 86,000 ft³ of ambient air, with consequent extraction of about 1/2 gram of suspended particulate (aerosol). This provides quite a substantial weight of sample, which greatly simplifies subsequent chemical or physical analysis.

The motor is usually started and stopped by a simple clock timer, and the duration of sampling is measured by an elapsed time meter that is placed in series with the Hi-Vol motor. Starting and finishing times are at the discretion of the operator, although the EPA recommends starting and finishing from midnight to midnight--24 hours every sixth day. The National Air Sampling Network operates such samplers over the entire country. On the other hand, short-term studies to determine day-to-day variation in particulate levels may require continuous daily 24-hour sampling.

7.2.3.2 Continuous Gas Analyzers

In general, these instruments are based on one of the following principles of operation: colorimetry, atomic or molecular absorption, chemiluminescence, conductivity, coulometry, or combustion.

In the past, colorimetric instructions have been used with varying degrees of success to monitor air by adapting classical color-forming reactions to such plumbing and electronics as were required to produce continuous recorded data. More recently, however, the realm of solid-state physics has produced gas-sensing equipment that respond to physical rather than chemical properties at even the lowest levels of gaseous air contaminants.

Therefore, emphasis is placed on the more recent physical instrumentation for the individual air contaminants. Future development in continuous air monitoring systems will probably be along the lines of physics rather than solution or chemical measurement.

Carbon Monoxide

Automated continuous methods for CO include applications of gas chromatography, nondispersive infrared absorption, catalytic oxidation, and displacement of Hg from HgO to produce mercury vapor.

The most commonly used instruments for CO measurement are those which use the principle of nondispersive infrared, employing either a long path (40 in) or, more recently, a 10 cm (0.39 in) path of infrared radiation.

These analyzers depend on the characteristic energy of absorption of the CO molecule at not only its absorption wavelength maximum of 4.6 μ but also at a number of equally specific lines ranging from 2 to 15 μ , which together differentiate CO from such interferences as CO₂, H₂O, SO₂ and NO₂.

As shown in Figure 7.2-18, these instruments employ a heated filament as the source of radiation, a chopper to alternate radiation between the sample and reference cells, a sample cell (usually copper or brass), a reference cell of the same material, and a detector.

Sulfur Dioxide (SO₂)

Among the earliest applications of continuous analyzers to ambient air monitoring were those involving measurement of SO₂. Both continuous and intermittent (sequential) sampling methods have been employed. These often made use of the colorimetric method of West and Gaeke. The West-Gaeke method was first adopted as the approved reference method by the National Air Pollution Control Association (NAPCA, 1969), before being replaced by the EPA colorimetric method.

For the past several years, the monitoring of sources such as kraft paper mills and oil refineries, whose emissions require a continuous total sulfur analyzer, has been accomplished by means of a total combined-sulfur flame photometer.

In this analyzer, sample air is admitted into a hydrogen-rich air flame. Specificity to sulfur arises from the use of a narrowband interference filter that shields the photomultiplier tube detector from all but the 394 m emission energy of flame-excited sulfur atoms.

Nitrogen Dioxide (NO₂)

Traditionally, continuous analyzers for NO₂ have employed the Griess-Saltzman modified colorimetric method. Recently, several continuous NO₂-measuring instruments operating on the principle of chemiluminescence have been marketed. Here, a photomultiplier detector is used to measure the luminescence produced in the gas phase reaction between ozone and NO.

This method directly measures NO rather than NO₂. It is mentioned here because it forms the basis for a reliable differential measurement of NO₂ through the use of a reducing medium such as stainless steel at 230°C, to convert NO₂ to NO. Subsequent reaction of NO, thus formed, with ozone produces chemilumi-

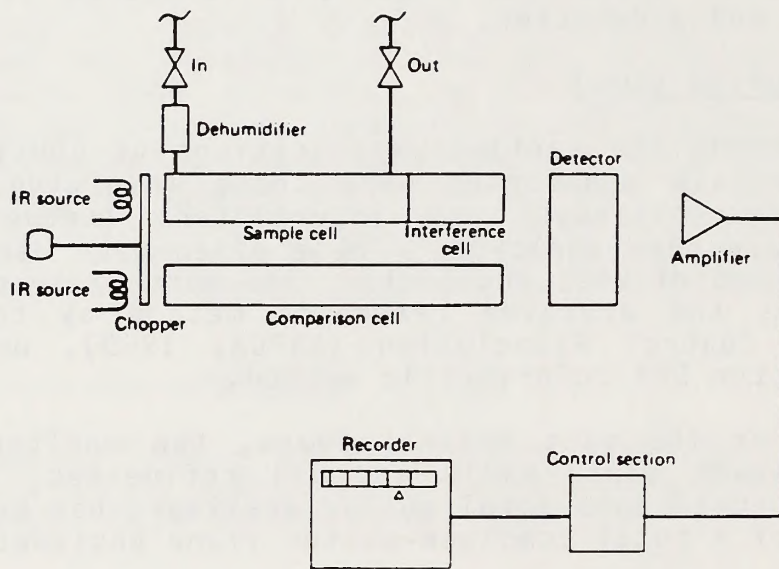

Figure 7.2-18
Diagram of Nondispersive Infrared Analyzer

nescence equivalent to NO_x , where $\text{NO}_2 = \text{NO} - \text{NO}$. The sensitivity of this method is reported as 0.01 ppm. To date, sufficient field experience has been obtained to indicate the overall reliability of the instrument over long periods of operation.

Ozone

The first chemiluminescence approach to a specific ozone determination probably was developed by Regener (1960). Regener found that, when air containing ozone contacts the surface of a plate prepared by absorbing rhodamine B on silica gel, a luminescence is produced from the chemical reaction. The intensity of the luminescence is proportional to the concentration of ozone present to concentrations as low as 0.001 ppm.

Regener's detector was found to be subject to a number of interferences, such as NO_2 . It was soon followed by the Nederbracht (1965) detector, which employs the chemiluminescence of the ethylene reaction with ozone.

A number of commercially available analyzers have now been marketed. It appears that the ozone-ethylene chemiluminescent reaction, having been adopted by the EPA as a standard method for ozone, will soon become the basis for the common continuous ozone field analyzer. Figure 7.2-19 presents a schematic of a continuous chemiluminescence ozone meter.

Hydrocarbons

Commercial instruments that automatically measure hydrocarbons fall into two main categories:

1. The total hydrocarbon continuous monitor, and
2. The semicontinuous nonmethane hydrocarbon monitor.

Briefly, automatic monitoring of hydrocarbon levels depends on the fact that most organic compounds easily pyrolyze when introduced into an air-hydrogen flame. This pyrolysis produces ions that are collected either by the metal of the flame jet itself (charged negative) or by a cylindrical collecting grid (positively charged) that surrounds the flame. The sensitivity to organic materials varies slightly depending on the number and kind of ions. As a general rule, however, detector response is in proportion to the number of carbon atoms in the chain of the organic molecule. Thus, propane (three carbon atoms) gives roughly three times the intensity of response as does methane, and so on.

This "nonselectivity" is both an advantage and a disadvantage, depending on the information expected from the air analysis. Nonselectivity toward hydrocarbons, but selectivity in the sense that other compounds do not cause response, provides this continuous instrument with the capability of measuring the

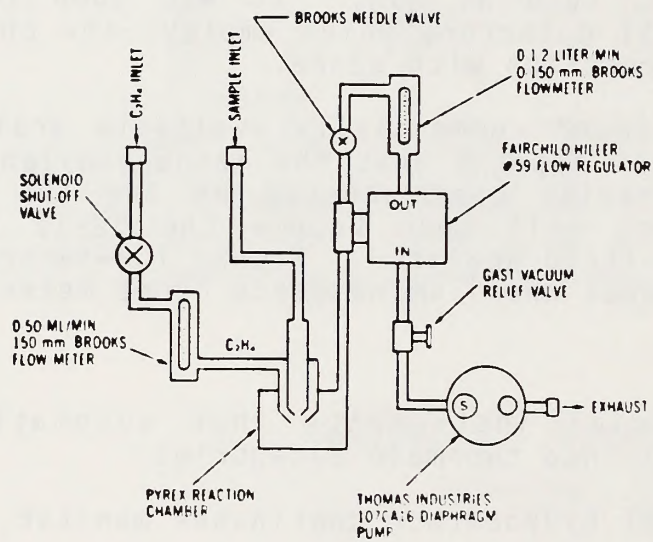

Figure 7.2-19
 Diagram of Air-Ethylene System for
 Continuous Chemiluminescent Ozone Meter

whole general class of organic compounds without concern for interference. When the instrument response is calibrated using methane, the continuous strip chart readout is then a record of the real-time variation in ambient hydrocarbons as though they were 100% methane.

The Federal ambient air quality standard of 0.24 ppm (6:00 to 9:00 a.m.) average for nonmethane hydrocarbons necessitates the selective measurement of this class of compounds in preference to total hydrocarbons, especially when elevated levels of ozone are either known or suspected.

This analysis is accomplished by a differential measurement using the following procedure. First, small measured volumes of air are delivered intermittently (4 to 12 times/hr) to a flame ionization detector to measure total hydrocarbons. Following this measurement, another similar sample volume is admitted into a stripper column, which removes the relatively heavy non-methane hydrocarbons and water. The effluent from this column, consisting of methane and CO, then enters a gas chromatograph for separation. The methane, which exits first, passes unchanged through a catalytic reduction tube and into the detector, where it is recognized as methane. Carbon monoxide, which exits next, passes through a platinum-hydrogen reducing atmosphere, and emerges as methane. It is thus detectable by the ionizing flame where it is electronically recognized as CO.

Nonmethane levels for these sequential samples results from subtracting the signal of the methane hydrocarbons from the total hydrocarbons where nonmethane HC = total HC - methane HC.

7.2.4 Monitoring Program Operation

Monitoring programs require a diversity of skills for the successful management of a complete program. Key components of a monitoring program include:

- Site Selection
- System Design
- Equipment Selection and Purchase
- Initial Calibration and Installation
- Onsite Surveillance, Maintenance and Repair
- Quarterly Calibration
- Data Handling, Reduction, Summarization and Analysis
- Quality Assurance
- Report Preparation

The costs associated with air quality and meteorological monitoring programs can be enormous. Therefore, it is important to isolate the specific data requirements necessary for a particular study area.

Tables 7.2-1 and 7.2-2 recommend various types of air monitoring and meteorological instrumentation that can provide

Table 7.2-1
Summary of Air Quality Monitoring Equipment

Parameter	Manufacturer or Source	Model	Cost	Instrument Type and Comments
Total Suspended Particulates	General Metal Works, Inc. 8368 Bridgetown Rd. Clevel, Ohio 45002	Various	\$500→\$1000	High-Volume Sampler. Options include flow control, timer/programmer, particle sizing, calibration kit.
TSP	Misco Scientific	Various	\$500→\$1000	High-Volume Sampler. Similar options. Special designs available.
TSP	Sierra Instruments	#305 & various	\$500→\$1000	High-Volume Sampler. Similar options.
Lead	Chemical analysis of TSP filters.	Same monitors as above.		
Sulfates	Chemical analysis of TSP filters.	Same monitors as above.		
Ozone	Dasibi Environmental Corp. 616 E. Colorado St. Glendale, CA. 91205	1003-AH	\$4000.00	Chemiluminescent Analyzer. Probably the best, UV absorption principle.
Ozone	Monitor Labs, Inc. 4202 Sorrento Valley Blvd. San Diego, CA. 92121	8410E	\$3025.00	Chemiluminescent Analyzer.
Ozone	Meloy Labs, Inc. 6715 Electronic Dr. Springfield, VA. 22151	0A 325-2R	\$3130.00	Chemiluminescent Analyzer.
Ozone	Bendix P. O. Drawer 831 Lewisburg, W. Va. 24901	8002	\$3950.00	Chemiluminescent Analyzer.
Ozone	Beckman Instruments, Inc. 2500 Harbor Blvd. Fullerton, CA. 92634	950 A	\$3645.00	Chemiluminescent Analyzer.

Table 7.2-1
Summary of Air Quality Monitoring Equipment
(Continued)

Parameter	Manufacturer or Source	Model	Cost	Instrument Type and Comments
SO ₂	TECO (Thermo Electron Corp.) 108 South Street Hopkinton, MA. 01748	43	\$6850.00	Pulsed Fluorescent Analyzer
SO ₂	Monitor Labs	8450E	\$4900.00	Flame Photometric Detection (FPD) Analyzer
SO ₂	MeLoy Labs	SA 285-E	\$4950.00	FPD Analyzer (4 linear ranges)
SO ₂	Bendix	8300	\$5885.00	FPD Analyzer
SO ₂	Beckman	953	\$6750.00	Chopped Fluorescence Analyzer
SO ₂	Phillips	PW 9755/02	\$6800.00	Coulometric Titration Analyzer
NO/NO ₂ /NO _x	Monitor Labs	8440 E	\$5375.00	Chemiluminescent Analyzer
NO/NO ₂ /NO _x	Bendix	8101 C	\$5870.00	Chemiluminescent Analyzer
NO/NO ₂ /NO _x	TECO	14 B/E	\$5775.00	Chemiluminescent Analyzer
NO/NO ₂ /NO _x	MeLoy Labs	NA 530-R	\$7500.00	Chemiluminescent Analyzer
NO/NO ₂ /NO _x	Beckman	952 A	\$5890.00	Chemiluminescent Analyzer
Methane (CH ₄) & total HC (THC)	Bendix	8201, 8202	\$5490.00	Flame Ionization Detection (FID) Analyzer
Methane (CH ₄) & total HC (THC)	MeLoy Labs	HC 500-2C	\$3780.00	FID Analyzer

Table 7.2-1
Summary of Air Quality Monitoring Equipment
(Continued)

Parameter	Manufacturer or Source	Model	Cost	Instrument Type and Comments
Methane(CH ₄) & total HC (THC)	Mine Safety Appliances (MSA) Co. 400 Penn Center Blvd. Pittsburgh, PA 15235	11-2	\$7200.00	Dual FID Analyzer
CO	Bendix	8501-5CA	\$6295.00	NDIR Analyzer
CO	MSA	Lira M202S	\$4270.00	NDIR Analyzer
CO, CH _y , HC, Ethylene	Beckman	6800 with options	\$10-\$15K	Out of production. Gas Chromatograph
CO, CH _y , HC Ethylene	Byron	Cannot locate any information.		
CO, CH _y , HC Ethylene	Bendix	Special Order	\$9K-\$12K	Any combinations available.
H ₂ S	(1) SO _x scrubber, then convert H ₂ S to SO ₂ for SO ₂ specific monitors. (2) Direct measurement using total sulphur analyzers with SO _x scrubbers.			
H ₂ S	Meloy Labs	SA 285-E	\$5100.00	FPD (2) Analyzer
H ₂ S	TECO	45	\$8550.00	FPD (1) Analyzer
H ₂ S	Philips	PW 9780/00	\$7000.00	FPD (2) Analyzer

Table 7.2-2
Summary of Meteorological Monitoring Equipment

Parameter	Manufacturer or Source	Model	Cost	Instrument Type and Comments
Wind Speed/ Wind Direction	Meteorology Research, Inc. (MRI) 464 West Woodbury Rd. Altadena, CA. 91001	1071	\$2500.00	Anemometer. Mechanical Station; includes temperature, built-in recorder. Options.
WS/WD	MRI	1074-2	\$3000.00	Anemometer. WS/WD sensors in one housing. Options. With signal processors.
WS/WD	MRI	1022	\$2800.00	Anemometer. Individual sensors. Options. With signal processors.
WS/WD	MRI	1053	\$4800.00	Anemometer. Measures azimuth, elevation, sigmas and WS. With signal processors.
WS/WD	Climatronics Corp. 1324 Motor Parkway Hauppauge, N.Y. 11787	EWS	\$2300.00	Anemometer. AC/DC powered. Includes temperature, recorder. Options.
WS/WD	Bendix Corp. Dept. 81 1400 Taylor Ave. Baltimore, MD. 21204	120	\$850.00	Anemometer. Aerovane. Translator Model 135 is \$900.00.
WS/WD	Met-One, Inc. 154 San Lazaro Sunnyvale, CA. 94086	WS→#010 WD→#020	\$1500.00	Anemometer. Micromet quality. With signal processors.
WS/WD	Met-One	WS→#014 WD→#024	\$1100.00	Anemometer. AC/DC portable system. With signal processors.
WS/WD	Texas Electronics, Inc. P. O. Box 7225 Dallas, TX. 75209	446A	\$1800.00	Anemometer. AC/DC with recorders and signal translator.

Table 7.2-2
Summary of Meteorological Monitoring Equipment
(Continued)

Parameter	Manufacturer or Source	Model	~ Cost	Instrument Type and Comments
WS/WD	Texas Electronics, Inc.	450LC-5	\$2500.00	Anemometer. Includes signal translators and recorders.
WS/WD	R. M. Young Company 2801 Aero-Park Drive Traverse City, MI. 49684	12002	\$1200.00	Anemometer. Gill microvane/anemometer.* Includes signal translator.
WS/WD	R. M. Young Company	21003	\$1800.00	Anemometer. Gill anemometer bivane.* Includes signal translator.
WS/WD	R. M. Young Company	35003	\$1500.00	Anemometer. Gill propeller vane.* Includes signal translator.
Temperature	MRI**	840-1	\$900.00	Thermometer. Power aspirated. Includes signal translator.
T	MRI	815-1	\$650.00	Thermometer. Naturally aspirated. Includes signal translator.
T	Met-One**	Shield→#076 Sensor→#060A	\$650.00	Thermometer. Power aspirated. Includes signal translator.
T	Met-One	Shield→#071 Sensor→#063	\$550.00	Thermometer. Vane aspirated. Includes signal translator.
T	Texas Electronics	R2-1015	\$500.00	Thermometer. Naturally aspirated. Includes signal translator and recorder.

* Fragile - not for rugged environments.
** Also can supply ΔT systems.

Table 7.2-2
 Summary of Meteorological Monitoring Equipment
 (Continued)

Parameters	Manufacturer or Source	Model	Cost	Instrument Type and Comments
T	R. M. Young Company**	Shield #43103A Sensor #78-0039-0007	\$550.00	Thermometer. Naturally aspirated. Includes signal conditioner.
T	R. M. Young Company	Shield #4304A Sensor #78-0039-0007	\$750.00	Thermometer. Power aspirated. Includes signal conditioner.
Precipitation	MRI	304	\$900.00	Rain gauge. Built-in recorder, battery operated.
Precipitation	MRI	302	\$600.00	Rain gauge. Includes signal conditioner. (No recorder.)
Precipitation	Climatronics	100097	\$650.00	Rain gauge. Includes signal translator.
Precipitation	Texas Electronics	R2-1014P	\$700.00	Rain gauge. Includes signal translator and recorder.
Visibility	MRI	1590	\$4000.00 to \$4500.00	Integrating nephelometer. Dependent on visual range requirements.
Visibility	MRI	3030	\$4300.00	Vista Ranger. Measurer over large path (tens of km). Quantitative & continuous output.

reliable data necessary for air quality/meteorological analyses. The cost associated with these particular types of instrumentation as presented in the tables include the purchase price only. Table 7.2-3 provides a review of total program costs as a function of the various components as detailed above. The range of cost varies from a simplistic approach (e.g., particulate sampling) to the sophisticated (e.g., full PSD permit support monitoring of gaseous, particulate and meteorological parameters). The prices vary from approximately \$10,000 to \$200,000 for a year of monitoring. A sophisticated, multiple site program can easily cost over one million dollars.

Figure 7.2-20 presents a schedule for the completion of a one-year monitoring program which indicates a 16 month period from project inception to completion. This schedule assumes that no problems arise. Realistically, it often takes two years to obtain one year of data.



Table 7.2-3
 Summary of Monitoring Program Costs

Site Selection	~\$1000
System Design	~\$ 500 - \$3000
Equipment Selection and Purchase	~\$2000 - \$100,000
Installation and Initial Calibration	~\$ 500 - \$5000
Onsite Surveillance, Maintenance and Repair	~\$5000 - \$50,000
Quarterly Calibrations	~\$ 500 - \$5000
Data Handling, Reduction, Summarization and Analysis	~\$1000 - \$10,000
Quality Assurance	~\$ 500 - \$5000
Report Preparation	~\$1000 - \$10,000

Figure 7.2-20
Proposed Project Schedule

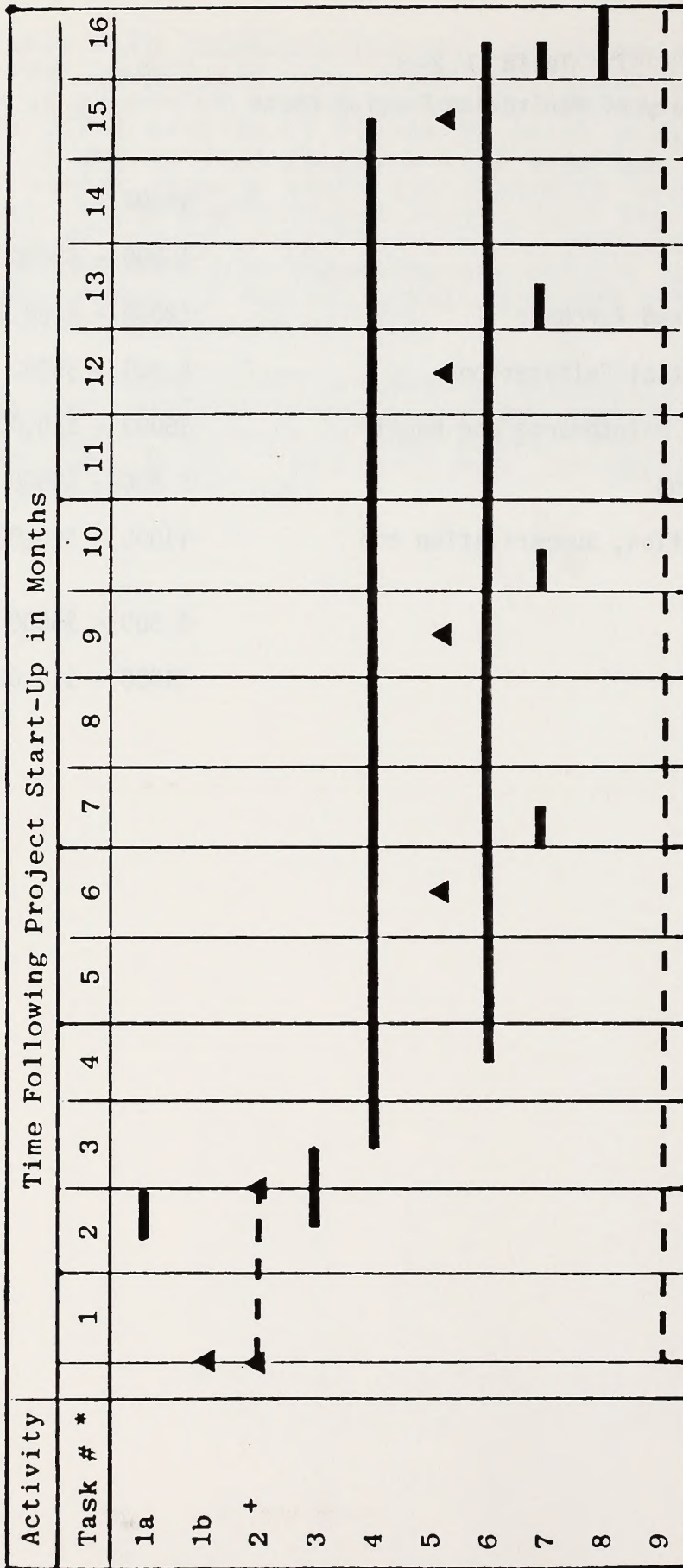

Tasks

- * 1. Task Organization
 - a) Job Procedure (JP) and Quality Assurance (QA) Manuals
 - b) Site Visit
- + 2. Equipment Ordering and Initial Calibration
- 3. Installation and Initial Calibration
- 4. Onsite Surveillance
- 5. Quarterly Calibrations
- 6. Data Reduction
- 7. Quarterly Reports
- 8. Final (Annual) Report
- 9. Task Management

7.3 SUSANVILLE DISTRICT MONITORING REQUIREMENTS

Many areas within the Susanville District lack substantial air quality, dispersion meteorology and climatological data necessary for Environmental Impact Statement (EIS) development and would require onsite air quality and/or meteorological monitoring programs to supply supportive data for future analyses. Table 7.3-1 provides an evaluation of the adequacy of the current data base for air quality impact analyses for lands currently under BLM jurisdiction. A satisfactory rating indicates that sufficient data exists within the particular area to provide site-specific information necessary to accurately describe the air quality/meteorological baseline. An unsatisfactory rating indicates that insufficient site-specific data are available for use in future EIS level analyses.

As outlined in Table 7.3-1, climatological data are available for all BLM lands in the Susanville District. These data are generally adequate for accurate site-specific assessments. On the other hand, considerable data resolution would be necessary for site-specific dispersion meteorology and air quality assessments for the various BLM land areas in the Susanville District.

Future Monitoring

The monitoring requirements required in support of air quality permit applications are an obligation of the Applicant. The data have been presented to inform the Federal Land Manager (FLM) of monitoring requirements, as the role of the FLM in the protection of air quality has increased in recent years. The 1977 Amendments require the FLM To take an active role in EPA's PSD permit process. In addition, the FLM must actively protect the "air quality related values", primarily visibility, of Class I Areas (i.e., national parks, monuments and wilderness areas [See Section 6.4]).

The FLM is charged with ensuring "reasonable progress" toward meeting the national goal of remedying impairment to visibility in Class I Areas. To do this, a visibility baseline must be established. BLM is presently entering into a Cooperative Agreement with the EPA which will begin visibility baseline studies for Class I areas in California. This program will be an expansion of the EPA's Western Fine Particulate Network which includes forty stations uniformly distributed throughout Montana, North Dakota, Wyoming, South Dakota, Utah, Colorado, Arizona and New Mexico. The purpose of this study is to determine the impacts of western energy resource development. Particulate samples are taken twice weekly and undergo mass concentration and trace element analysis.

The visibility monitoring program will include two initial site locations. One site will be located in the Susanville District and one within a desert area of the Riverside

Table 7.3-1

Summary of the Adequacy of Climatological,
Dispersion Meteorological and Air Quality Data
for BLM Lands in the Susanville District

Parameters	Data Adequacy
Climatology	
Temperature	Satisfactory
Precipitation	Satisfactory
Others	Satisfactory
Dispersion Meteorology	
Wind Speed	Unsatisfactory
Wind Direction	Unsatisfactory
Stability	Unsatisfactory
Winds Aloft	Unsatisfactory
Mixing Height	Unsatisfactory
Air Quality	
TSP	Unsatisfactory ¹
SO ₂	Unsatisfactory ²
NO ₂	Unsatisfactory ²
O ₃ ^x	Unsatisfactory ²
CO	Unsatisfactory ²
Visibility	Unsatisfactory

Satisfactory - Sufficient site-specific data to accurately describe a particular parameter for future EIS analyses.

Unsatisfactory - Insufficient site-specific data to accurately describe a particular parameter for future EIS analyses.

¹ Satisfactory in Plumas and Sierra Counties.

² While data are not sufficient for categorization, the area is felt to be better than standards for this pollutant.

District as mandated by the EPA. The objective of the program is to measure visibility, aerosol characteristics and climatology in remote areas influenced by industrial expansion and population growth. The program is also to differentiate between natural and man-made contributions to visibility degradation.

In addition to sophisticated visibility measurements by telephotometers, nephelometers and color photography, size segregated particulate sampling will be conducted with subsequent trace element analysis. The measurement program will be supported by basic meteorological monitoring including wind speed and direction, temperature and relative humidity.

Baseline visibility is poorly defined in the Susanville District. However, monitoring programs should emphasize those areas that incorporate or are adjacent to Class I areas.

7.4 GLOSSARY OF TERMS

Accuracy	The closeness of the instrument output to the true value of the parameter.
Anisotropic Turbulence	Turbulence which is directionally dependent.
Bi-Vane	A wind direction instrument designed to rotate around a vertical axis to measure the azimuth and elevation angle of the wind.
Chemiluminescence	The use of a filter multiplier detector to measure the luminescence produced in a gas phase reaction between two species.
Chromatograph	Analyzers used for the separation and measurement of volatile compounds and of compounds that can be quantitatively converted into volatile derivatives.
Colorimetry	The exhaustive quantitative electrolysis of a species being measured by electrolytic generation of a color free agent which reacts quantitatively with the measured species.
Conductivity	The property or power of conducting or transmitting heat, electricity, etc.
Constant Level Balloons	Constant level balloons are used to determine the trajectory of an air parcel at a desired pressure level during a given time interval.
Coulometry	Coulometric analysis is based on exhaustive quantitative electrolysis of the species being measured by electrolytic generation of an agent which reacts quantitatively with measured species.
Durability	The ability of an instrument to survive vibrations and shock encountered in transportation, rough handling and normal operating conditions.
Dustfall	The simple collection of dust due to gravitational settling.
Dynamic Response	The real time reaction of an instrument.
Flame Ionization	The ionization of gas samples through their introduction into an air hydrogen flame. Species specific ions are then measured by a detector which measures ion intensity resulting from the flame ionization of any organic compound.

Flame Photometry	The use of a hydrogen rich air flame to induce the emission of excited atoms specific to the pollutant being measured.
Griess-Saltzman Method	A continuous colorimetric method for NO ₂ detection.
High-Volume	The collection of particulate matter on a filter medium through the collection of an air sample at a continuous standard rate.
Hydrothermograph	An instrument for the measurement of temperature and humidity through the use of human hairs which increase or shorten as a function of atmospheric moisture content.
Nephelometer	An instrument which indicates visibility impairment due to the presence of particulate matter in the atmosphere.
Net Radiation	The difference between the total incoming radiation and the outgoing terrestrial radiation.
Net Radiometer	An instrument for the measurement of net radiation.
Nondispersive Infrared Absorption	The use of the principle whereby gaseous compounds absorb infrared radiation at specific wave lengths. In nondispersive absorption, a detector is exposed to a wide wave length band of radiation.
Pilot Balloon	A method for the measurement of wind velocity and wind direction as a function of height using a gas filled free balloon.
Precision	The degree of closeness of a series of readings of an unchanging parameter.
Psychrometer	An instrument which combines a dry bulb and wet bulb thermometer for the subsequent calculation of humidity.
Pyranometer	An instrument used to measure direct radiation.
Pyrheliometer	An instrument used for the continuous measurement of direct solar radiation.
Radiosonde	The use of a free balloon to carry meteorological sensors and a radio transmitter aloft.

Rawinsonde	A method of measuring winds aloft using a gas filled free balloon and radio direction finding apparatus, usually radar.
Reliability	The ability of an air quality or meteorological instrument to provide reproduceable results.
Sensitivity	The smallest change in the measured variable that causes a detectable change in the output of the instrument.
Simplicity	Describes an instrument that can be operated by an individual through the use of Standard Operating Procedures.
T-Sonde	The use of a free balloon to carry a temperature sensor and radio transmitter aloft.
Theodolite	An optical system used to measure the azimuth and elevation angle of a pilot balloon.
Total Radiation	The direct radiation from the sun plus the diffuse radiation from the sky.
Transmissometer	An instrument used for the measurement of visibility through the measurement of the transmission of light over a fixed baseline. Usually on the order of 500 - 700 feet.
UVW Anemometer	An anemometer designed to measure wind speed in the horizontal (x and y directions) and vertical.

BIBLIOGRAPHY

- Angell, J.K. and Pack, H.J., "Analysis of Some Preliminary Low Level Constant Level Balloon, (Tetroon) Flights." Monthly Weather Review, 88, pages 235-248, 1960.
- Cooke, T.H. "A Smoke Trail Technique for Measuring Wind" - Quarterly Journal of the Royal Meteorological Society, 88, pages 83-88, 1962.
- U.S. Department of Health, Education and Welfare, "Air Quality Criteria for Sulfur Oxides" Chapter 2, page 21, Washington, D.C., January, 1969.
- U.S. Environmental Protection Agency, "Ambient Monitoring Guidelines for Prevention of Significant Deterioration (PSD)", EPA 450/Q-78-019, May, 1978 (OAQPS No 1.2-096).
- U.S. Environmental Protection Agency, "Air Pollution Meteorology", Control Programs Development Division, Research Triangle Park, North Carolina, 1973.
- Warner, Peter O., Analysis of Air Pollutants, John Wiley and Sons, 1976.

BLM Library
Bldg. 50
Denver Federal Center
P.O. Box 25047
Denver, Colorado 80225

CALIFORNIA STATE OFFICE

CENTRAL LIBRARY COPY

... AMENDMENTS

... VILLE DISTRICT

... VILLE DISTRICT

OVERLAY A
BLM LANDS SUSANVILLE DISTRICT

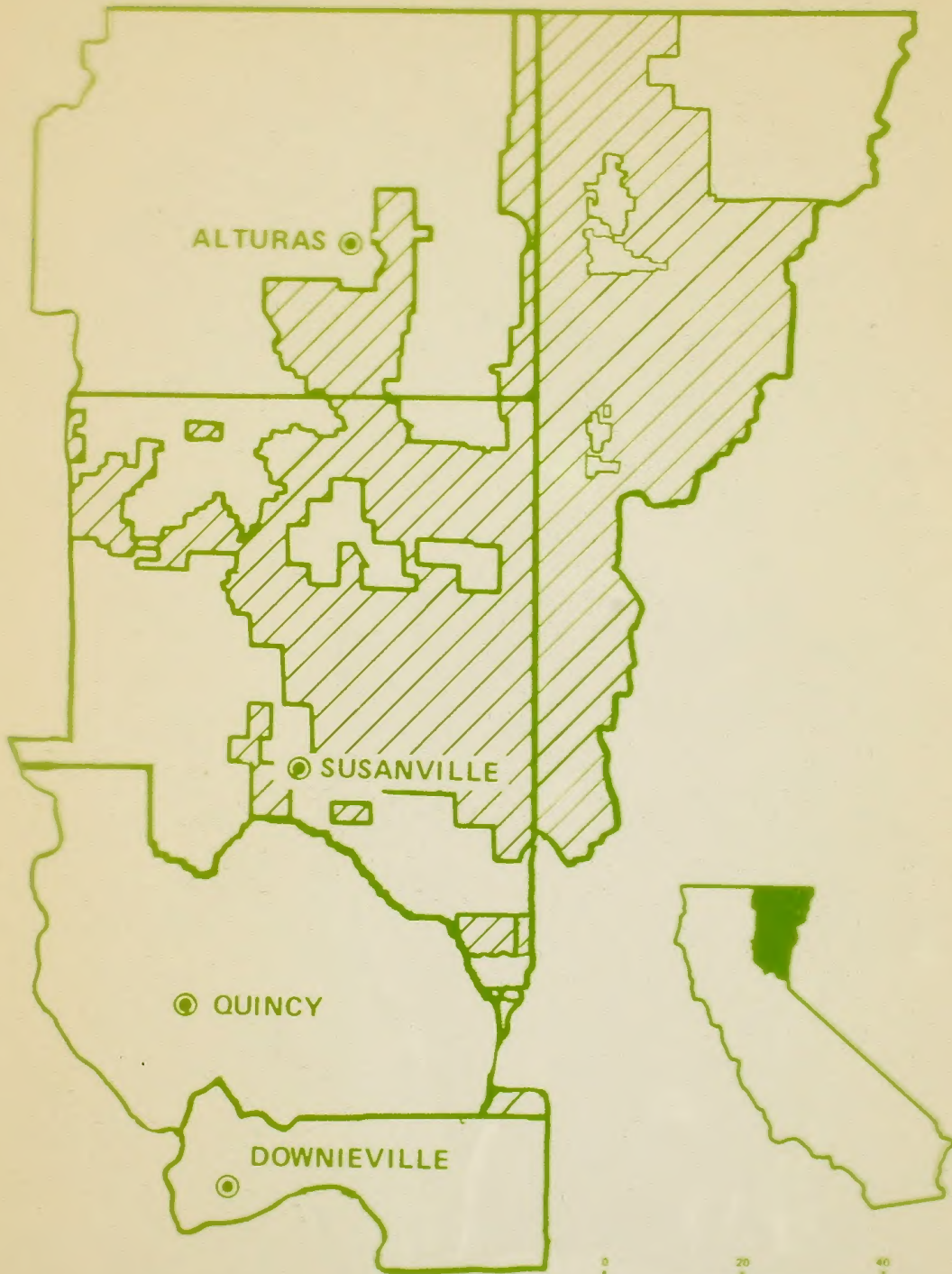

 BUREAU OF LAND
MANAGEMENT DOMAIN

OVERLAY B SUSANVILLE DISTRICT TOPOGRAPHY

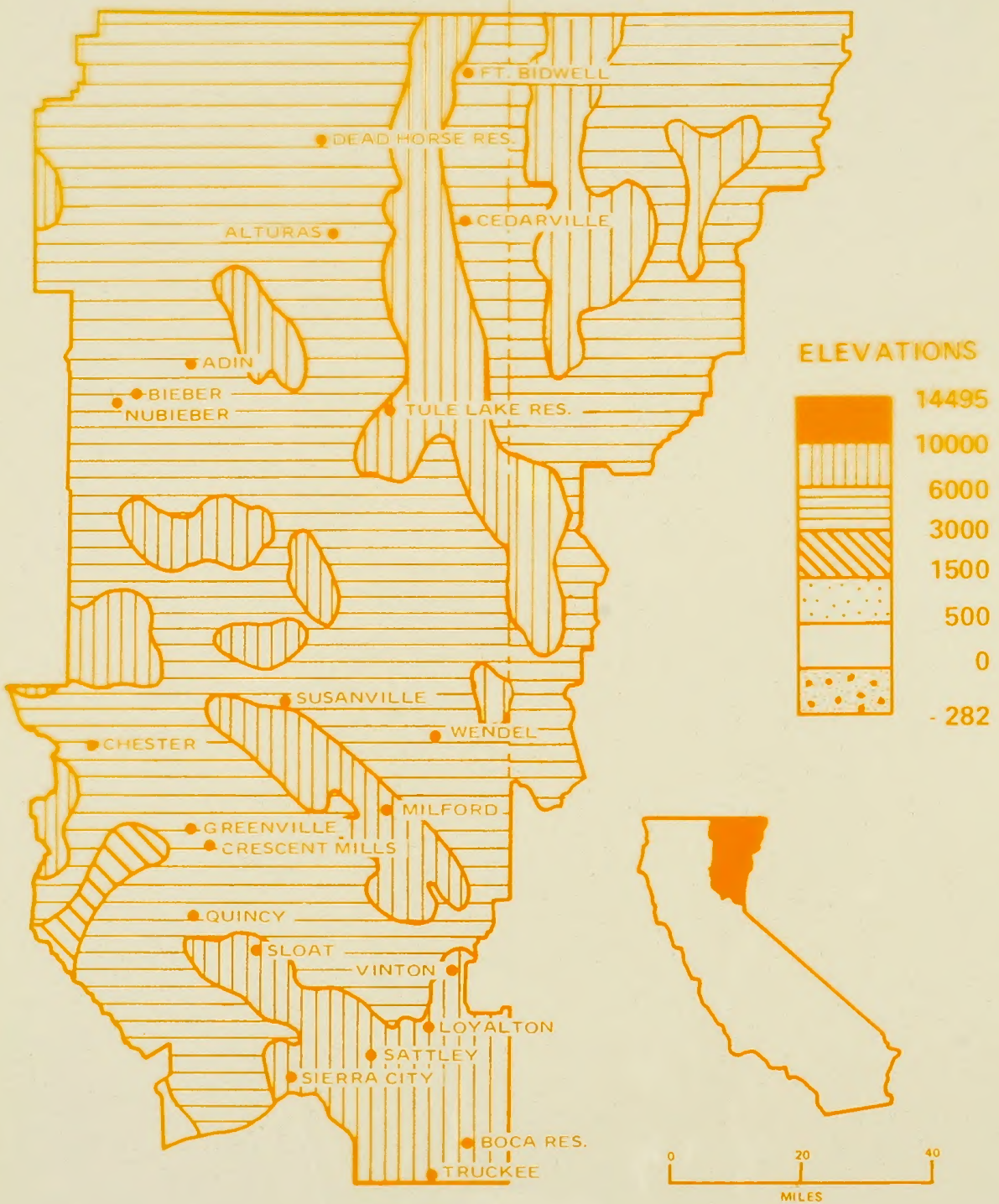

OVERLAY C
CLIMATIC ZONES FOR SUSANVILLE DISTRICT

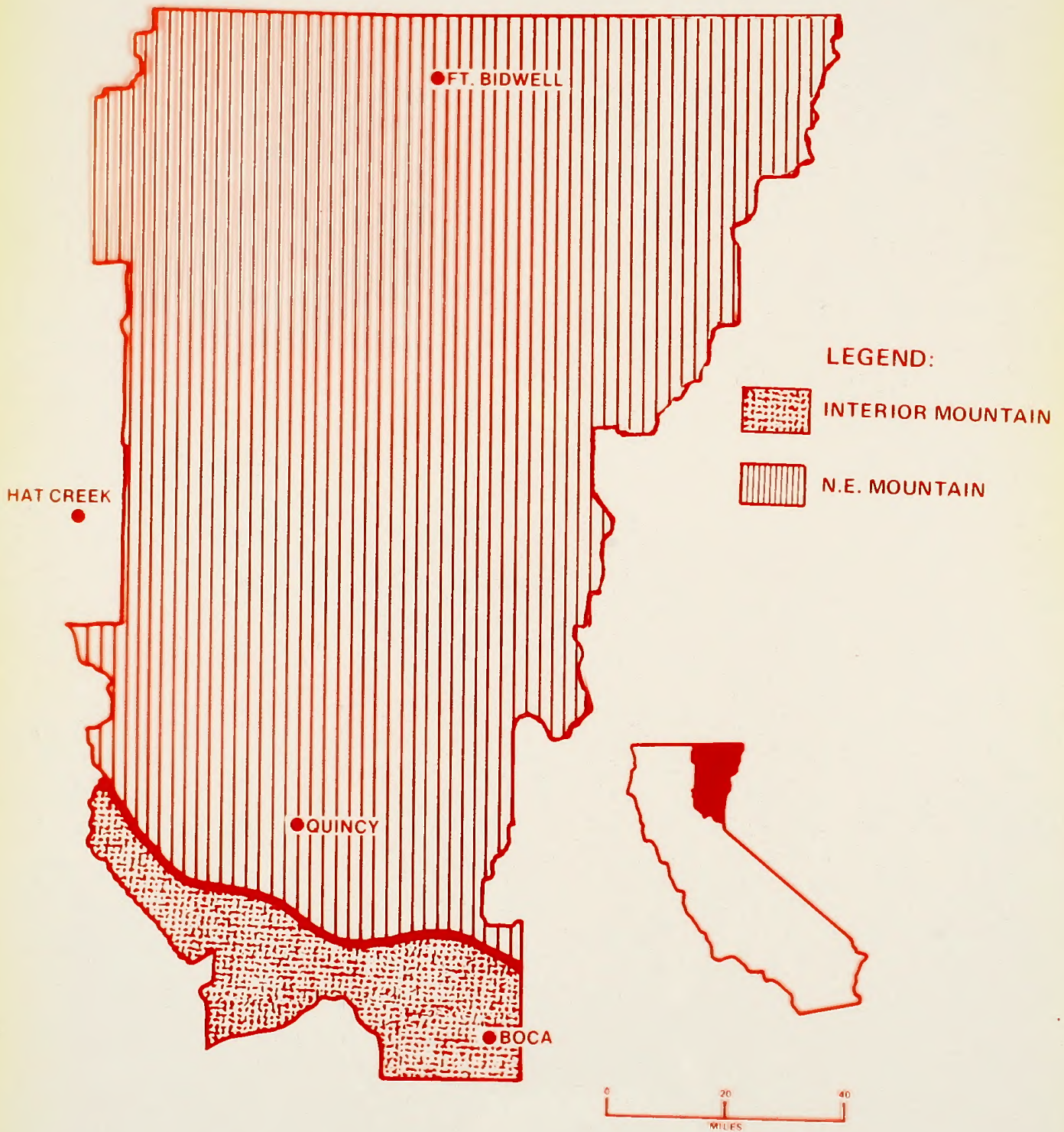

OVERLAY D
MEAN ANNUAL TEMPERATURE CONTOURS (°F)



OVERLAY E
MEAN ANNUAL PRECIPITATION (INCHES)

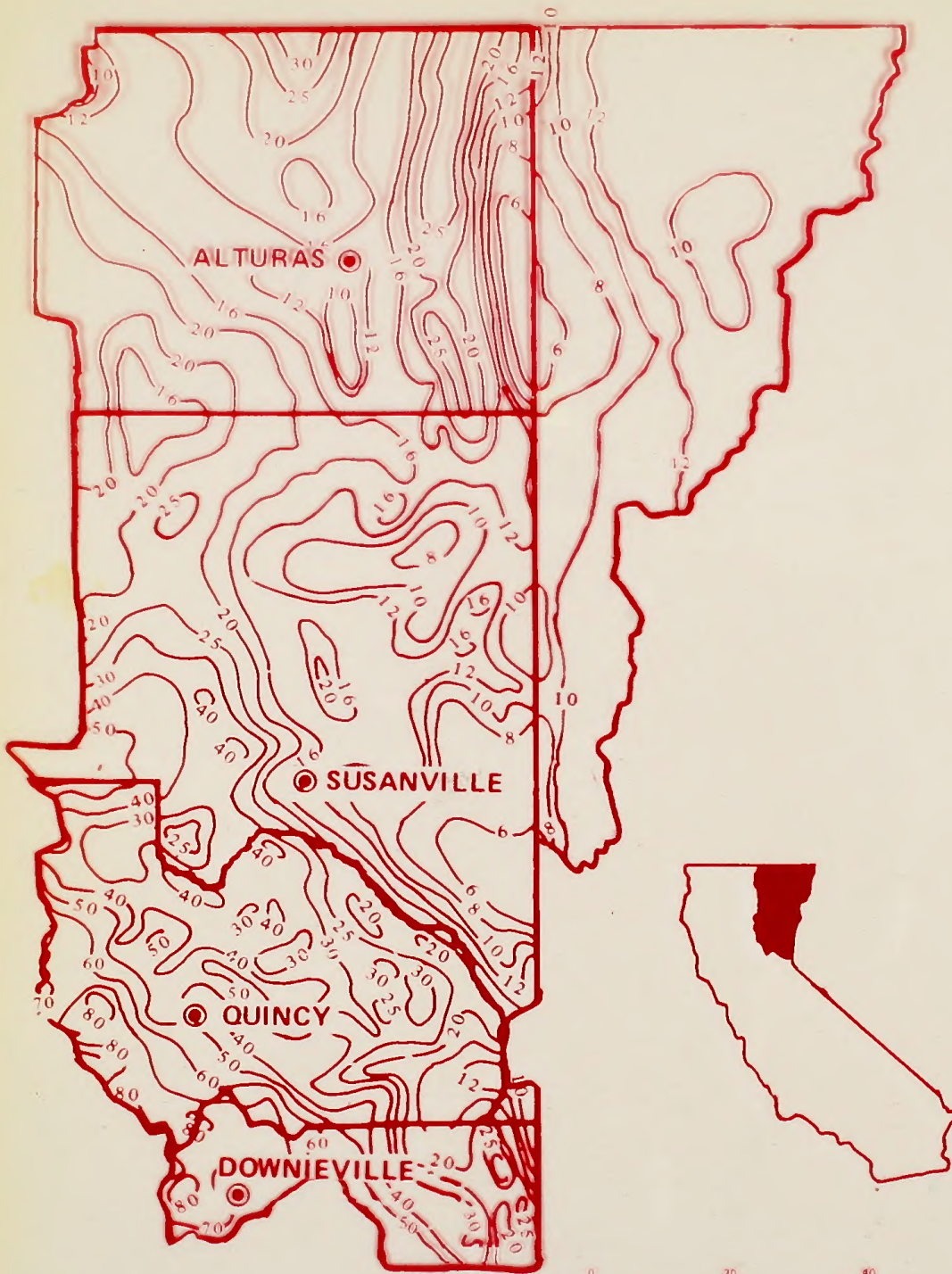

OVERLAY F
CALIFORNIA AIR BASINS IN THE SUSANVILLE DISTRICT

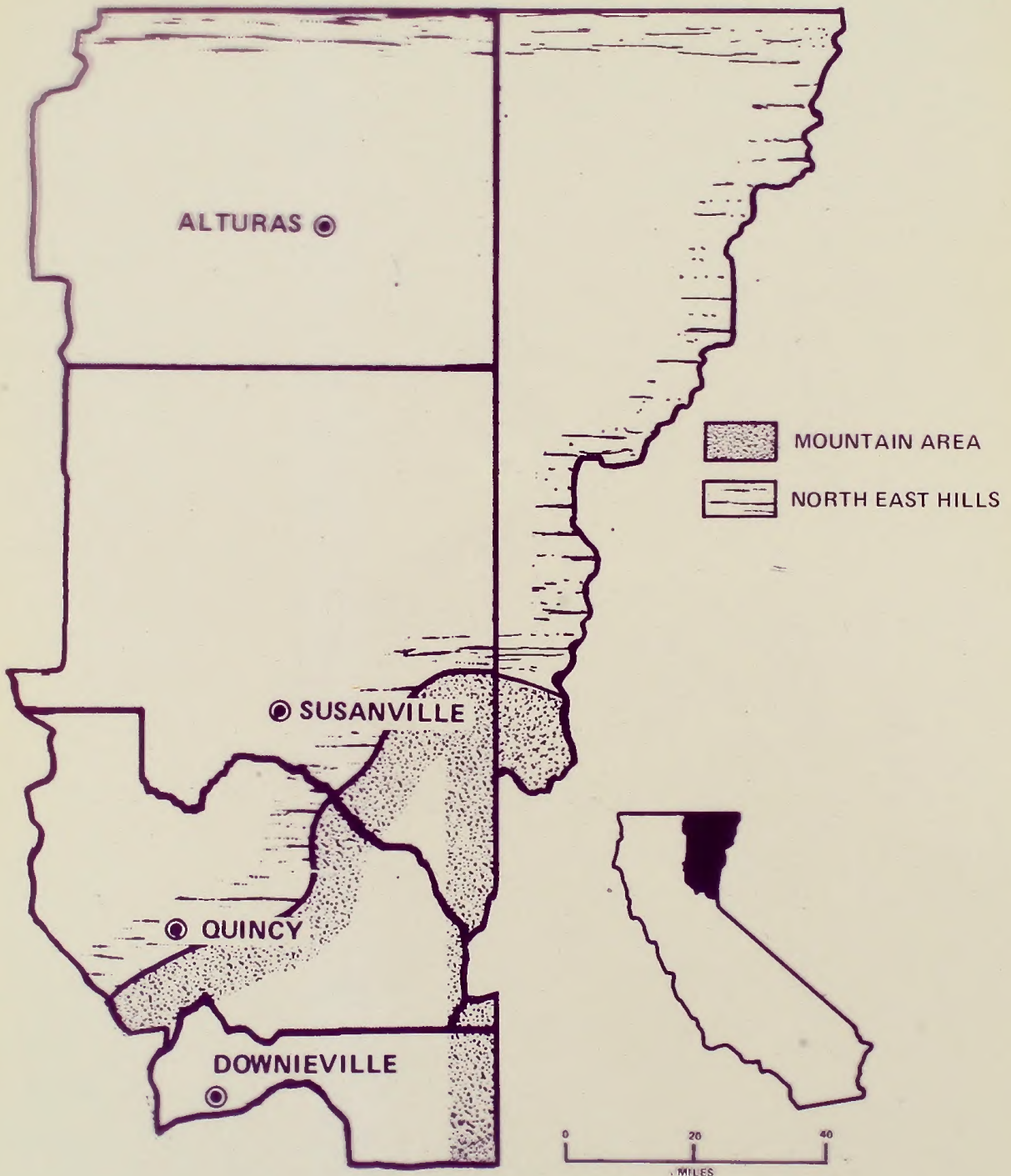

OVERLAY G
MANDATORY CLASS I AREAS UNDER 1977 CLEAN AIR ACT AMENDMENTS



VERLY G
CLEAN AIR ACT AMENDMENTS
DISTRICT
DISTRICT

COLUMBIAN BROWN CLASP NO. 97B
Westvaco—USEnvelope Division
10 x 13

BORROWER'S CARD

QC 882 .S873 1980 v.1

Baseline meteorology and air
quality in the Susanville

BORROWER	OFFICE	DATE RETURNED

(Continued on reverse)

QC 882 .S873 1980 v.1

Baseline meteorology and air
quality in the Susanville

