

3 1430 02617437 7

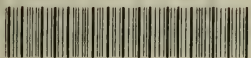

a31430026174377b

UNIV. OF MD. COLLEGE PARK

*National Trust*  
*for*  
*Historic Preservation*



LIBRARY

ARCH

NTL

TH

145

146

Vol 2



Digitized by the Internet Archive  
in 2011 with funding from  
LYRASIS members and Sloan Foundation



# PART III.

## TRUSSED ROOFS AND ROOF TRUSSES.

(IN PREPARATION )

### TABLE OF CONTENTS.

#### INTRODUCTION.

	CHAPTER I.
Definitions. Types of Wooden Trusses.	
	CHAPTER II.
Types of Steel Trusses.	
	CHAPTER III.
Layout of Trussed Roofs.	
	CHAPTER IV.
Bracing of Roofs and Trusses.	
	CHAPTER V.
Open Timber Roofs and Church Roofs.	
	CHAPTER VI.
Vaulted and Domed Roofs and Ceilings.	
	CHAPTER VII.
Computing the Truss Loads.	
	CHAPTER VIII.
Stress Diagrams for Vertical Loads.	
	CHAPTER IX.
Stress Diagrams for Wind and Snow.	
	CHAPTER X.
Stresses found by Computation.	
	CHAPTER XI.
Rules and Tables for Proportioning the members to the stresses.	
	CHAPTER XII.
Joints in Wooden Trusses—Rules and Tables for.	
	CHAPTER XIII.
Joints in Steel Trusses.	
	CHAPTER XIV.
Examples of trussed Roofs and Roof Trusses.	

# BUILDING CONSTRUCTION

AND SUPERINTENDENCE.

---

BY F. E. KIDDER, C. E., PH.D.,  
ARCHITECT.

*Fellow American Institute of Architects.  
Author of "The Architects' and Builders' Pocket Book."*

---

PART II.  
FIFTH EDITION.  
CARPENTERS' WORK.  
*525 Illustrations.*

---

New York :  
WILLIAM T. COMSTOCK,  
23 Warren Street.  
1905.

3754

COPYRIGHT,  
F. E. KIDDER.  
1898.

---

COPYRIGHT,  
F. E. KIDDER.  
1899.

---

COPYRIGHT,  
F. E. KIDDER.  
1900.

---

COPYRIGHT,  
F. E. KIDDER.  
1902.

---

COPYRIGHT,  
F. E. KIDDER.  
1905.

---



## PREFACE.

---

IT has been the aim of the Author, in preparing this work, to furnish a series of books that shall be of practical value to all who have to do with building operations, and especially to architects, draughtsmen and builders. In this volume an attempt has been made to describe those materials and methods of construction that come within the ordinary province of the carpenter, or are usually included in the carpenter's specifications.

In treating the various subjects that come within the scope of the book, the descriptive method used in Part I., with numerous illustrations, has been followed, as this appears to be the most practical method of accomplishing the end in view. But little space has been given to methods of determining the strength of materials, these having already been sufficiently covered in various works treating particularly of such matters, the especial aim of the author being rather to show how the various kinds of work should be done, what materials should be used and how the parts of buildings should be put together.

To do this in a manner that would be of sufficient practical value to warrant its being done at all, has required the making of a large number of detail drawings, which, while they have greatly increased the labor of preparation and delayed the publication, will, the author dares to believe, prove of great assistance to the young architect and draughtsman, and he trusts of some value to experienced architects and builders.

The illustrations may not be considered as models of draughtsmanship, but on a small scale are such as are usually required in making working drawings and in explaining the method of construction to be pursued. It is hoped that their value may be in proportion to the labor and thought that have been expended upon them.

The various materials employed by the carpenter, or with which he usually has to do, have also been carefully considered, with the view of enabling the architect and builder to employ them wisely, and to distinguish between the various kinds and qualities.

An especial effort has been made, in describing different forms of construction, not to follow entirely the methods of one section of the country, but rather to give the different methods pursued by different architects and in different localities, contrast them, and bring out their relative advantages. In this the author has been greatly assisted by many prominent architects, and by his own experience in both the Eastern and Western portions of the country.

The method of paragraphing the subjects followed in Part I. has been retained, partly for convenience in making cross references and also for greater convenience in the class room. Much pains have been taken to make the Index as complete as possible, using the most suggestive terms, so that any subject may readily be found.

In referring to the supervision of the work the author has attempted to call attention to the defects commonly found in building materials and to inferior methods of construction, and various ways in which the work is often slighted.

The general duties of a superintendent have been so well set forth in Mr. T. M. Clark's well-known work, "Building Superintendence," that it seems unwise to go more fully into this part of the subject, especially as the best preparation for efficient supervision is a thorough knowledge of how the work should be done, and that the author has tried to impart.

There are so many patented articles and devices used in connection with the carpenter's work that are not only desirable, but often absolutely necessary to the proper equipment of a building, and with which, therefore, the architect should be acquainted, that it has been necessary to describe or refer to quite a number, but only such have been recommended as have been thoroughly investigated, or which the author has successfully used in his own practice.

In conclusion, the author wishes to acknowledge the great assistance he has received from various architects, and especially from Prof. C. A. Martin, of Cornell University, in regard to various details of construction, and also from several manufacturers of Builders' hardware for information and illustrations.

The author will appreciate any suggestions that may be made looking to the improvement of future editions, or any corrections of errors that may be discovered.

F. E. KIDDER.

*Denver, August 1, 1898.*

# TABLE OF CONTENTS.

## CHAPTER I.

- The Building and Finishing Woods of the United States..... 9**  
Their characteristics, properties and uses—Selection of timber—Decay of timber—Preservation of timber—Kiln-drying—Varieties of timber—Imported woods—Merchant sizes—Market prices.

## CHAPTER II.

- Wood Framing.—Ordinary Construction..... 46**  
Framing timber—Framing of wooden buildings—Framing of floors, girders, wall anchors; supports for partitions—Roof framing construction—Superintendence.

## CHAPTER III.

- Sheathing, Windows and Outside Door Frames..... 106**  
Sheathing of walls and roof—Cellar frames—Types of windows; construction of window frames in frame and brick walls; patent windows, casement windows, pivoted windows, bay windows—Sash, store fronts—Glass and glazing; stock windows—Outside door frames—Superintendence.

## CHAPTER IV.

- Outside Finish, Gutters, Shingle Roofs..... 151**  
Eaves and gable finish, verge boards, gutters and conductors—Wall shingling and siding—Sheathing papers—Joining wooden and stone walls—Porches—Dormers—Wooden skylights—Shingle roofs, flashing and counter flashing—Tin roofs—Superintendence.

## CHAPTER V.

- Interior Woodwork, Rough Work, Doors, Standing Finish, Floors, Stairs..... 204**  
Under floors—Deafening of floors and partitions; deafening materials—Back-plastering, sheathing lath—Furring for finish and plastering, furring for chimney breasts—Grounds and corner beads, metal corner beads—Interior finish, operations in joinery, joints, mouldings—Doors and door frames—Finish of doors and windows—Inside shutters, sliding blinds, rolling and Venetian blinds—Wainscoting, base, chair rail, picture mouldings, etc.—Paneling, wooden beams, cornices, columns, etc.—Stairs, arrangement, construction and finish, posts and railing—Fixtures and fittings, bookcases and drawers—Dimensions for furniture—Upper floors material and laying, parquetry—Superintendence.

## CHAPTER VI.

<b>Builders' Hardware</b> .....	323
Rough hardware, bolts, nails, screws—Finished hardware—Door trimmings, hinges, butts, spring butts, sliding door hangers, locks, knobs, bolts, door checks, transom fixtures—Ornamental hardware—Window trimmings, pulleys, sash cords and chains, sash fasts and locks, sash lifts—French window trimmings—Trimmings for shutters, outside blinds and windows; trimmings for cupboards and drawers—Prices of hardware.	

## CHAPTER VII.

<b>Heavy Framing</b> .....	419
Bowled floors—Framing of galleries—Framing of stores and warehouses, post and girder connections—Bracing of posts and girders—Framing for area walls—Floors supported by trusses—Girders, compound wooden girders, trussed girders—Mill construction—Superintendence.	

## CHAPTER VIII.

<b>Specifications</b> .....	462
Carpenters' work for frame and brick buildings, glass—Joiners' work—Stairs—Hardware and trimmings.	
<b>Appendix A</b> .....	505
<i>Patented devices</i> used in connection with carpenters' work—Rolling partitions—Revolving doors—Dumb waiters—The Cutler Mail Chute.	
<b>Appendix B</b> .....	523
<i>Tables of the Strength of Materials</i> .—Strength of iron and steel rods, wood and cast iron columns, gas pipe columns—Strength of wooden beams—Maximum span for floor joists.	

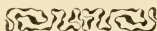

## CHAPTER I.

# THE BUILDING AND FINISHING WOODS OF THE UNITED STATES.

---

**1. Characteristics, Properties and Uses.**—The abundance and consequent cheapness of wood in the United States, the ease with which it can be procured and worked, together with its strength, lightness and durability, have caused it to enter largely into the construction of all but the most costly buildings, and it will probably continue to be for many years the most widely useful material of construction.

In spite of the many substitutes for it in the shape of metal, stones, plaster, paper and other materials, the per capita consumption of wood in this country has increased at the rate of from 20 to 25 per cent. for every decade since 1860.

Considering its wide and extensive use in buildings, it is evidently important that the architect should be well informed in regard to its properties, characteristics, manufacture, treatment and adaptability, that he may use it wisely and economically.

There are so many variable conditions, however, that affect the value of wood for constructional and finishing purposes that it is quite impossible for any one but a specialist to acquire a thorough knowledge of the subject, and in a work of this character it is only possible to treat the subject somewhat superficially.

### THE TREE.

**2.** All wood used in the United States for building construction and finishing comes from what are known as *exogenous trees*, or those which increase in size by the formation of new wood each year on its outer surface.

All of these trees are covered with a more or less scaly material called bark, which envelopes the wood and is removed in the process of manufacture into lumber.

The wood of these trees is made up of bundles of long tubes, cells or fibres, with their long axis generally parallel to the stem of the tree. Crossing these fibres in a radial direction from the pith to the

bark are other fibres which are known as pith fibres or medullary rays, and which serve the purpose of binding the whole together. Besides these wood fibres there are resin ducts scattered through the wood of the pines and spruces, and in the wood of the broad-leaved trees hollow ducts or vessels.

The various fibres and vessels above mentioned differ in both their shape and disposition in different kinds of trees, and consequently give rise to differences in the structure of the wood, and it is often only by a microscopical examination of the structure that the different varieties of the same kind of woods can be determined.

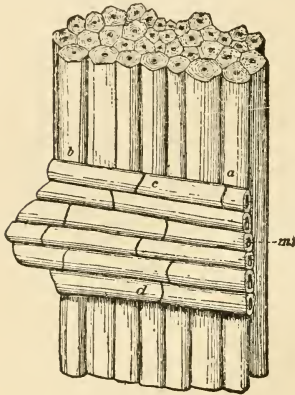

Fig. 1.

The structure of the wood determines to a large extent its appearance when finished, and also has a marked influence upon its physical and mechanical properties.

Fig. 1 shows a bundle of wood fibres, *a b*, highly magnified, with the pith or medullary rays, *c d*, running at right angles to them.

Fig. 2 shows a block of oak, not magnified, in which the medullary rays are very prominent. These medullary rays occur in all woods, but in the soft woods they are not generally noticed. They give the peculiar silver-mottled effect seen in quarter-sawed oak, and add much to the appearance of most of the hard woods. They also form a large part of the wood of all trees—in pine over 15,000 of these pith rays occur on a square inch of tangential section, and even in oak the very large rays, which are readily visible to the eye, repre-

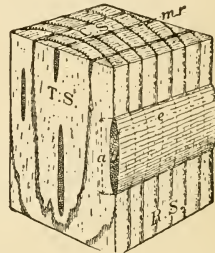

Fig. 2.—Block of Oak. C. S., cross section; R. S., radial section; T. S., tangential section; m. r., medullary or pith ray; a, height; b, width, and c, length of a pith ray.

sent scarcely a hundredth part of the number which the microscope reveals.

Besides affecting the appearance of the wood the medullary rays also greatly affect the shrinkage and checking of the wood in seasoning, and have much to do with the strength of the wood.

**3. Growth of the Tree.**—The process of growth of exogenous trees in a temperate climate is as follows:

“In the spring the roots absorb juices from the soil, which are converted into sap and ascend through the cellular tubes to form the leaves. At the upper surface of the leaves the sap gives off moisture, absorbs carbon from the air and becomes denser; after the leaves are full grown vegetation is suspended until autumn, when the sap in its altered state descends chiefly between the wood and the bark, where it deposits a layer of new wood (the annual ring for that year), a portion at the same time being absorbed by the bark. The new wood thus formed covers all parts of the stem and branches.”

As the tree increases with age the inner layers become choked or filled with the secretory substance peculiar to the tree and fall out of use, except as they serve the mechanical function of keeping the tree from breaking under its own weight or from the force of the wind. This process of growth, therefore, produces two kinds of wood in the same tree, viz., the *sapwood* and the *heartwood*.

Practically speaking, the sapwood of trees is that portion of the wood where the cells are open to the upward passage of the sap. It varies in width and in the number of rings which it contains, even in different parts of the same tree. It also varies considerably in different kinds of trees; it is small in the hard woods and in the long leaf and white pines, and great in loblolly and Norway pines. The sapwood possesses but little strength and is subject to rapid decay, owing to the great quantity of fermentable matter contained in it.

**4. The Annual Rings—Spring and Summer Wood.**—The layers of wood that are formed each year appear as rings on the cross section of the log, and by counting them the age of that portion of the tree may be determined.

The width of these yearly rings varies greatly in different trees and also in different parts of the same tree. The average width of the rings in well grown old white pine will vary from  $\frac{1}{12}$  to  $\frac{1}{18}$  inch, while in the slower growing long-leaf pine it may be  $\frac{1}{25}$  to  $\frac{1}{30}$  of an inch. While these rings are approximately circular in shape, it is very seldom that they are a true circle; usually they are oval in shape, and at the stump they commonly form quite an irregular figure

"The greater regularity or irregularity of the annual rings has much to do with the technical qualities of the timber."

*Spring and Summer Wood.*—If the annual rings are examined closely it will be noticed that each ring is made up of an inner, softer, light-colored portion, and an outer, firmer and darker colored portion. Being formed in the fore part of the season, the inner, light-colored part is termed *spring wood*, the outer, darker portion being the *summer wood* of the ring.

The summer wood is much firmer and heavier than the spring wood, and hence the greater the proportion of summer wood to the total volume the greater will be both the weight and strength of the timber.

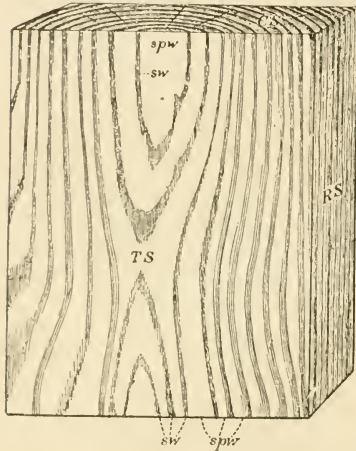

Fig. 3.—Board of Pine. CS, cross section; RS, radial section; TS, tangential section; sw, summer wood; spw, spring wood.

The darker color of the summer wood also influences the shade of color of the entire piece of wood, and in the pines this color effect affords a valuable aid in distinguishing the heavy and strong from the light and soft woods.

"In some trees like the hard pines the dark summer wood appears as a distinct band, so that the yearly ring is composed of

two sharply-defined bands—an inner, the spring wood, and an outer, the summer wood. But in some cases, even in hard pines, and normally in the wood of white pines, the spring wood passes gradually into the darker summer wood, so that a sharply-defined line occurs only where the spring wood abuts against the summer wood of its inner neighbor. It is this clearly-defined line which enables the eye to distinguish even the very narrow rings in old pines and spruces."

In a pine board, sawed from near the centre of the log, the spring and summer woods will appear about as shown in Fig. 3, an inner, lighter strip and its outer, darker neighbor always corresponding to one annual ring. If the tree was perfectly straight and the rings of



uniform thickness, the spring and summer wood would appear on the face of the board as parallel bands, but, owing to the irregularity of the growth, the two kinds of wood usually form a variety of pleasing patterns on the face of bastard boards.

Where a saw cut passes through a bump or crook of the log, irregular concentric circlets and ovals are produced, and on almost all bastard boards arrow or V-shaped forms occur.

**5. Hard and Soft Woods.**—Although no dividing line between these two classes of woods is universally recognized, the “hard woods” are generally classed as those cut from broad-leaved trees and the “soft woods” as those from coniferous or needle-leaved trees, such as the pines, spruce and cedar.

“Though alike in their manner of growth, and therefore similar in their general make-up, conifers and broad-leaved trees differ markedly in the details of their structure and the character of their wood. The wood of all conifers is very simple in its structure, the fibres composing the main part of the wood being all alike and their arrangement regular.

“The wood of broad-leaved trees is complex in structure; it is made up of several different kinds of cells and fibres and lacks the regularity of arrangement peculiar to the conifers.”\*

#### PHYSICAL PROPERTIES AND CHARACTERISTICS.

**6. Grain of Wood.**—In common usage wood is said to be “coarse grained” when its annual rings are wide and “fine grained” when they are narrow. The term “fine grained” is also sometimes applied to those woods which are capable of high polish, and this depends chiefly on the hardness of the wood. When the direction of the fibres is parallel to the axis of the stem or limb the wood is “straight grained,” and when the course of the fibres is spiral or twisted around the tree the wood is “cross grained.” Sometimes the fibres take the shape of fine waves, when the wood is said to be wavy or “curly” grain. The latter is frequently seen in maple.

Generally the surface of the tree under the bark is not uniform and smooth, but has more or less elevations or depressions, and the same is also true of the layers in the interior. In some woods these depressions or elevations are maintained in only a few layers, while in others they increase from year to year. On tangent boards of such woods the section of these pits and prominences appear as circlets and give rise to beautiful figures. In maple the tendency to

\* Filbert Roth, Bulletin No. 10, U. S. Department of Agriculture.

preserve any particular contour is very great, and as the depressions and elevations are usually small and very numerous, they appear on the face of the boards as very fine circlets, and hence the term "bird's-eye" maple.

The branches or limbs of a tree also affect the grain and the appearance of a board cut through or near them.

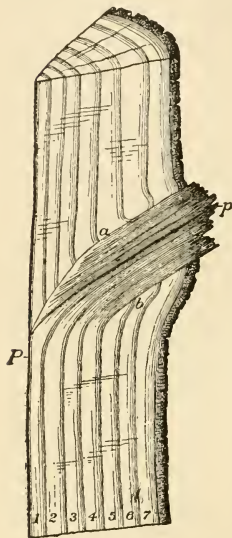

Fig. 4.—Section of Wood Showing Position of the Grain at Base of a Limb. *P*, pith of both stem and limb; 1-7, seven yearly layers of wood; *a*, *b*, kno. or basal part of a limb which lived four years, then died and broke off near the stem, leaving the part to the left of *a*, *b* a "sound" knot, the part to the right a "dead" knot, which would soon be entirely covered by the growing stem.

"At the junction of a branch with the stem of the tree the fibres on the upper and lower sides of the branch behave differently. On the lower side they run from the stem into the limb, forming an uninterrupted strand or tissue and a perfect union [as shown in Fig. 4]. On the upper side the fibres bend aside and are not continuous into the limb."

Owing to this arrangement of the fibres the cleft made in splitting never runs into the knot if started above the limb, but is apt to enter the knot if started below.

When limbs die, decay and break off the remaining stubs are surrounded and finally covered by the growth of the trunk.

So long as these knots preserve their natural color they are not classed as dead, but are nevertheless dead from the point where they cease to be united with the living wood.

Dead knots in pine and spruce almost always become loose, so that when the log is sawed into boards the sections of the knots drop out.

**7. Color and Odor.**—The color of wood lends to its beauty, aids in its identification and is of great assistance in judging of its quality. Each different variety of wood has its own peculiar color, at least for the heartwood, and this when known offers a reliable mark of distinction.

Newly-formed wood, like that of the outer few rings, has little

color. In all trees the sapwood is generally light, and in the hard woods there is often a great difference in the color of the sapwood and heartwood.

The color of good timber should be uniform throughout the heartwood; when it is blotchy or varies much in color from the heart outward, or becomes pale suddenly toward the limit of the sapwood, it is probably diseased.

“When wood is attacked by fungi it becomes more opaque, loses its brightness, and in practice is designated ‘dead’ in distinction to ‘live’ or bright timber.

“Exposure to air darkens all wood; direct sunlight and occasional moistening hasten this change and cause it to penetrate deeper. Prolonged immersion has the same effect, pine wood becoming a dark gray, while oak changes to a blackish brown.”

The odor of wood is caused by chemical substances contained in it, but which form no part of the wood substance itself. Exposure to weather reduces and often changes the odor, but most of the soft woods exhale apparently as much odor as ever when a fresh surface is exposed.

Many kinds of wood are distinguished by strong and peculiar odors, which aid in identifying the variety, and in some cases give the wood a peculiar value.

Decomposition is usually accompanied by pronounced odors; decaying poplar emits a disagreeable odor, while red oak often becomes fragrant, its smell resembling that of heliotrope.

**8. Resonance.**—If a piece of timber is struck with a hammer a sound is emitted which varies in pitch and character with the shape and size of the stick, and also with the kind and condition of the wood.

A dull, heavy sound indicates decay in the timber. Knots and irregularities in structure also affect the character of the sound emitted.

Thin boards may also be set vibrating by sound waves produced in the air. This property is utilized in the construction of many musical instruments and in architecture in the construction of sounding boards for reinforcing the voice of a speaker or the music of a choir or orchestra.

The ability of a properly shaped sounding board to respond freely to all the notes of an instrument or of the human voice depends first on the structure of the wood and next on the uniformity of the same

throughout the board. Sounding boards should be made as thin as practicable, and the wood should be free from knots, cross grain or resinous tracts and thoroughly and carefully seasoned.

"Spruce is the favored resonance wood; it is used for sounding boards both in pianos and violins."

**9. Weight of Wood.**—The weight of any particular piece of wood depends upon two main factors: The proportion of wood substance contained in the piece and the amount of water contained in the wood.

The weight of the wood substance is practically the same in all woods, viz., about 1.6 times as heavy as water. As the wood cells, however, are in most cases filled with air, this reduces the weight of the wood and causes it to float. When wood is immersed in water for a long time the water soaks into the cells, and when most of them become filled the wood sinks.

When the wall of the wood fibre is very thick the wood sinks whether the cells are empty or not. As the proportion of wood substance in the dark bands of summer wood is much greater than in the lighter colored spring woods, it follows that those woods which contain the greater proportion of summer wood are the heaviest.

The difference in the weight of green wood and that which has been seasoned is due to the quantity of sap contained in the cells of the green wood.

In a thrifty young pine the wood is lightest at the centre of the tree and grows gradually heavier toward the bark; in an old oak the reverse is true.

The weight of wood is in itself an important quality. It assists in distinguishing different woods, and light weight, when coupled with great strength and stiffness, makes the wood especially valuable for many purposes. To a large extent, also, weight indicates the strength of wood, at least of the same species.

"For any given species of timber, and for any given degree of dryness, the strength is almost directly proportionate to the weight."

The weight of kiln-dried wood of different species is given by Mr. Roth as follows:

APPROXIMATE WEIGHT OF KILN-DRIED WOOD OF DIFFERENT SPECIES.

	SPECIFIC WEIGHT.	WEIGHT OF—	
		1 CUBIC FOOT.	1,000 FEET OF LUMBER.
(a) Very heavy woods:		Pounds.	Pounds.
Hickory, oak, persimmon, osage orange, black locust, hackberry, blue beech, best of elm and ash.....	0.70-0.80	42-48	3,700
(b) Heavy woods:			
Ash, elm, cherry, birch, maple, beech, walnut, sour gum, coffee tree, honey locust, best of Southern pine and tamarack.....	.60- .70	36-42	3,200
(c) Woods of medium weight:			
Southern pine, pitch pine, tamarack, Douglas spruce, western hemlock, sweet gum, soft maple, sycamore, sassafras, mulberry, light grades of birch and cherry.....	.50- .60	30-36	2,700
(d) Light woods:			
Norway and bull pine, red cedar, cypress, hemlock, the heavier spruce and fir, redwood, basswood, chestnut, butternut, tulip, catalpa, buckeye, heavier grades of poplar....	.40- .50	24-30	2,200
(e) Very light woods:			
White pine, spruce, fir, white cedar, poplar....	.30- .40	18-24	1,800

The weight of ordinary lumber as found in lumber yards will generally average 33 per cent. heavier than the above values.

**10. Moisture in Wood.\***—“Water may occur in wood in three conditions: (1) It forms over 90 per cent. of the life-giving contents of the living cells; (2) it saturates the walls of all cells, and (3) it entirely, or at least partly, fills the cavities of the lifeless cells, fibres and vessels. In the sapwood of pine it occurs in all three forms; in the heartwood it merely saturates the walls.

“Of 100 pounds of water associated with 100 pounds of dry-wood substance in 200 pounds of fresh sapwood of white pine about 35 pounds are needed to saturate the cell walls, less than 5 pounds are contained in the living cells and the remaining 60 pounds partly fill the cavities of the wood fibres. This latter forms the sap as ordinarily understood. It is water brought from the soil, containing small quantities of mineral salts, and in certain species of trees, as

\* This section is taken largely from Bulletin No. 10, U. S. Department of Agriculture.

the maple and birch, it also contains at certain times a small percentage of sugar and other organic matter. These organic substances are the dissolved reserve food, stored during winter in the pith rays of the wood and bark; generally but a mere trace of them is to be found. From this it appears that the solids contained in the sap, such as albumen, gum, sugar, etc., cannot exercise the influence on the strength of the wood that is sometimes claimed for them."

In all exogenous trees the wood next to the bark contains the most water and the centre of the tree the least. In trees forming heartwood the change from a moist to a drier condition is usually quite abrupt at the sapwood limit; thus in long-leaf pine the wood of the outer 1 inch of the tree may contain 50 per cent. of water, that of the next inch only 35 per cent. and that of the heartwood only 20 per cent.

Different trees, even of the same kind and from the same place, differ as to the amount of water they contain. A thrifty tree contains more water than a stunted one, and a young tree more than an old one, while the wood of all trees varies in its moisture relations with the season of the year.

In the living tree of certain species, and at certain seasons, the sap will flow when the tree is tapped, but from boards, timber, etc., the water does not flow out under normal conditions, but must be evaporated.

When the tree contains clefts or shakes water will sometimes flow from them when the tree is sawed into lumber. From very sappy wood water is forced out whenever the wood is warmed.

Before the living wood can be made suitable for building or other mechanical purposes most of the moisture which it contains must be eliminated. If the sap is not expelled or dried up it putrefies and causes decay. After a tree is cut, if left in a dry place, the moisture will gradually evaporate, and as this takes place the wood shrinks and often cracks; hence it is desirable that the wood should shrink all it will before it is put into a building or a piece of furniture.

**II. Seasoning of Timber.**—This is simply evaporating the sap and moisture contained in the green wood either by natural or artificial means.

After the log is converted into lumber, the boards, planks or timbers are "stacked" in the lumber yard for seasoning. In building the stacks the pieces are laid in courses or layers, usually about 6 feet wide, and inch strips are placed between the layers so that the air may circulate through the stack. It requires a long time for wood

to season in the open air, and it never becomes sufficiently dry to answer for fine interior finishing or for furniture.

Framing lumber, however, is seldom dried in any other way, and it is seldom that it is allowed to stay in the yard for more than three or four months, consequently most of the lumber used in the frame, floors and partitions of ordinary buildings is generally comparatively green, and the seasoning must be completed in the building. It is the shrinkage of the lumber due to this final seasoning that causes most of the cracks in the interior of buildings having wooden floors and partitions. To prevent these cracks it is very desirable that the building should be commenced in the spring, so that the frame may season during the warm, dry weather of summer.

For special cases, where it is very desirable to have well-seasoned lumber, as for truss timbers or beams supporting brickwork, a search through the lumber yards will often result in finding a few pieces that have been seasoning for several years. The railway corporations and many large manufacturing concerns keep a large stock of lumber constantly on hand, so that it may be kept in the stack several years before using.

**12. Kiln-Drying.**—As it is impossible to season wood by natural means so that it will not shrink when put in a building that is to be kept warm and dry, it is necessary to dry all lumber that is to be used for finishing or in the manufacture of furniture by artificial means.

For this purpose a tight chamber called a dry kiln is constructed, and a constant current of air heated from 150° to 180° F. is made to pass over the lumber.

Pine, spruce, cypress, cedar, etc., may be put in the kiln fresh from the saw, allowing four days for 1-inch boards. Hard woods, especially oak, ash, maple, birch and sycamore, should be air-seasoned from three to six months to allow the first shrinkage to take place gradually before it is put in the kiln, and should then be exposed to the above temperatures for from six to ten days for 1-inch lumber.

Steaming lumber is often resorted to in order to prevent checking and "case-hardening," and also to make it bend more easily when bent pieces are required.

"The rapidity with which water is evaporated, that is the rate of drying, depends on the size and shape of the piece and on the structure of the wood.

"An inch board dries more than four times as fast as a 4-inch plank and more than twenty times as fast as a 10-inch timber.

White pine dries faster than oak. Water also evaporates faster from a cross section than from a longitudinal section and twice as fast from a radial section as from a tangential section."

Dry wood when soaked in water soon regains its original volume, and wood that has been kiln-dried at once takes up water from the air, even in the driest weather; hence the necessity of having the building dry before delivering the finishing lumber and of keeping it dry thereafter.

This property of wood of absorbing moisture may be lessened by boiling and steaming, and also by exposure in dry air to a temperature of 300° F. for a short time, but cannot be entirely overcome.

*Case-Hardening.*—Rapidly dried in the kiln, the wood of oak and other hard woods "case-harden," that is, the outer part dries and shrinks before the interior has a chance to do the same, and thus forms a firm shell or case of shrunken, commonly checked wood around the interior. This shell does not prevent the interior from

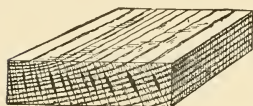

Fig. 5—"Honeycombed" Board. The checks or cracks form along the pith rays.

drying, but when this drying occurs the interior is commonly checked along the medullary rays, as shown in Fig. 5. In practice this occurrence can be prevented by steaming the lumber in the kiln, and still better by drying the wood in the open air or in a shed before placing in the kiln.

Since only the first shrinkage is apt

to check the wood, any kind of lumber which has once been air-dried (from three to six months for 1-inch stuff) may be subjected to kiln heat without any danger.

**13. Measure of Dryness.**—The only reliable measure of dryness is that of weight. Professor J. B. Johnson, engineer in charge of the U. S. Timber Tests, offers the following recommendation, which appears to have much practical value:

It would be well for architects to specify definite maximum percentages of moisture which would be allowed in lumber to be used in various kinds of interior finishing work instead of the usual specification of "thoroughly seasoned lumber" or "kiln-dried lumber." As such terms as these usually have to be interpreted by the judgment of different individuals, and as the legal determination of the fact always rests upon the testimony of various witnesses, each having his own interpretation of the meaning of such terms, it follows that the standards so established are extremely indefinite and unsatisfactory. *If the architect would specify a particular percentage of moisture* for flooring, for instance, by saying that it should not contain more than 10 per cent. of its weight in water, this is a specification which is



perfectly definite and the fulfillment of which is easily determined. Thus, when the flooring is delivered at the building, the architect may select a half dozen flooring boards from the lot and cut sections from their central portions about 1 foot long and take them to the nearest grocery or drug store and have them carefully weighed. He can then dry them out by putting them into an ordinary cook stove oven and keeping them there for a few hours at a temperature somewhat greater than boiling. He can then weigh them again, quickly, before they have re-absorbed atmospheric moisture, wrapping them up carefully if it is necessary to carry them any distance for the purpose of weighing. *The difference between the two weights divided by the dry weight gives the percentage of moisture in terms of the dry weight.* (Thus, if a piece weighs 44 ounces when first weighed and 40 ounces when taken from the oven, the percentage of moisture would be  $4 \div 40$ , or 10.)

Since the moisture in the air in inhabited buildings is rarely less than 10 per cent., this may be taken as the standard moisture for "thoroughly seasoned lumber." Twelve per cent. of moisture would probably not be detrimental, and in buildings that are not warmed above  $68^{\circ}$  F., even 15 per cent. may be allowed.

As a check on the fulfillment of the specifications, kiln-dried lumber should be tested for moisture immediately upon its delivery, for if the building is in the least damp the lumber will quickly absorb additional moisture from the air.

Framing timber and outside finishing lumber may be considered as well seasoned when it only contains 15 per cent. of moisture.

**14. Shrinkage of Wood.**—When a short piece of wood fibre, such as that shown in Fig. 6, is dried, it shrinks, its walls grow thinner

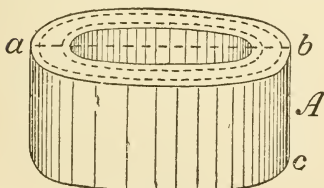

Fig. 6.

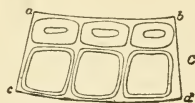

Fig. 7.—Warping of Wood.

(as indicated by the dotted lines), its width,  $a b$ , becomes smaller and the cavity larger, but the height or length,  $b c$ , remains the same.

The thinner the walls of the fibre the less also is the shrinkage.

The end walls of the fibres also shrink in the same way as the sides, but as the length is often a hundred or more times as great as the diameter, the effect of the longitudinal shrinkage is inappreciable.

A thin cross section of several fibres shrinks in the same way, the

walls of each fibre become thinner and the whole piece contracts in proportion. Where the cells are very similar in size and thickness the piece shrinks by about the same amount on all sides, but if the piece is made up of fibres, some of which have thin and others thick walls, then the row of thick-walled cells, shrinking much more than the row of thin-walled cells, the piece becomes unevenly shrunk or warped, as shown in Fig. 7. Not only is the wood warped, but the force which led to this warping continues to strain the interior parts of the piece in different directions.

"Since in all our woods cells with thick walls and cells with thin walls are more or less intermixed, and especially as the spring wood and summer wood nearly always differ from each other in this respect, strains and tendencies to warp are always active when wood dries out."

The pith or medullary rays also have a marked effect upon the shrinkage of wood.

As was shown in Section 2, the cells of the pith rays have their length at right angles to the direction of the wood fibres; hence as the pith rays dry they pull on the longitudinal fibres and try to shorten them, and, being resisted by the rigidity of the fibres, the pith ray is greatly strained. The fibres also shrink at right angles to the pith rays, and the latter in opposing this prevent the former from shrinking as much as they otherwise would. Thus the structure is subjected to two severe strains at right angles to each other, and it is principally owing to these strains that whenever the wood dries rapidly the pith rays separate and checks result, which, whether visible or not, are detrimental in the use of the wood.

"The contraction of the pith rays parallel to the length of the board is probably one of the causes of the small amount of longitudinal shrinkage which has been observed in boards."\*

**15. Effect of Shrinkage.**—Owing to the opposing of the shrinking of the fibres in a radial direction by the pith rays, all woods shrink more in a tangential direction, or around the rings, than in a radial direction, and this greater tangential shrinkage affects every phase of woodworking.

The effect of seasoning upon a log is shown at *A*, Fig. 8. The external portions of the wood shrink the most and the heartwood but little, and the wood splits in radial lines from the centre parallel with the medullary rays, but maintains its original diameter.

\* This longitudinal shrinkage, however, is so very slight that in practice it is customary to assume that the length of a timber is not affected by shrinkage.

Sawed in half, the log shrinks as shown at *B*, and if converted into boards by sawing in the usual way, the boards take the forms shown at *D*, all owing to the greater tangential shrinkage of the wood.

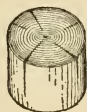

*A* If the log is cut into four square timbers, one edge being in the centre, the pieces will shrink to the shape shown in Fig. 9. It will be seen that in this case the diagonal, *d c*, remains unchanged, but the thickness of the timber each way is less and the angles are no longer square. Timbers sawn in this way, however, are much less liable to check than when sawn as shown at *C*, Fig. 3.

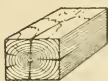

*C* Timbers sawn as in Fig. 9 are known as quartered wood. A round shaft turned from a quartered timber before the latter had seasoned would shrink as shown in Fig. 10.



Fig. 8.—Effects of Shrinkage.

There is also a great difference in the effects of shrinkage in different woods. The soft woods, such as pine, spruce, cypress, redwood, etc., with their very regular structure, dry and shrink evenly and suffer much less in seasoning than the hard woods. Among the latter oak is the most difficult to

dry without injury.

Small-sized split ware and quarter-sawed boards season better than ordinary boards and planks.

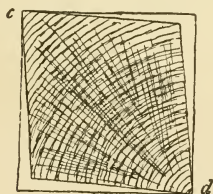

Fig. 9.



Fig. 10.

To avoid warping and checking all high-grade stock is carefully seasoned before manufacture.

When boards or planks which have shrunk to a curved form have to be used to form a flat board, they should be sawn lengthways into

strips and glued together, the alternate strips being reversed as in Fig. 11. In this way the curvature in each piece becomes very slight, and the reversal of the alternate pieces causes each piece to be a check upon the shrinkage of its neighbors.



Fig. 11.

In constructing fine cabinet work large and thick pieces of wood should be avoided, and if required should be made up of a number of thin pieces glued together; large surfaces should be made in panels, or of smaller pieces covered with veneer.

Large timbers, when used for posts, are less liable to check if a 1-inch or 1½-inch hole is bored longitudinally through the timber. This hole should be connected with the outer air by ½-inch holes near the top and bottom of the post.

Large wooden beams and girders may be largely kept from twisting and checking by cutting the beam in halves through the heart of the log and bolting the two pieces together *with the heart sides outward*, as shown in Fig. 12.

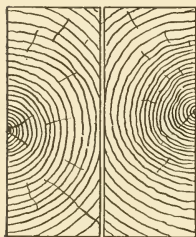

Fig. 12.

Although only the first shrinkage is apt to check the wood, repeated swelling due to changes of moisture increases the injuries produced in the first seasoning, so that wood should always be protected from moisture when once it is dry.

*Bent Wood.*—Steaming wood permits it to be bent more easily, and if the wood is bent before seasoning and kept in position until seasoned, it retains its bent shape and firmly opposes any attempt at subsequent straightening.

**16. Amount of Shrinkage.**—The shrinkage of wood varies for different species and even in different parts of the same tree; hence any figures that may be given for the shrinkage of wood must be regarded as mere approximations. Sapwood, as a rule, shrinks more than heartwood of the same weight, but very heavy heartwood may shrink more than lighter sapwood. Quarter-sawed boards shrink less in width than those that are bastard sawed, but more in thickness.

The following table, given by Mr. Roth in the Government bulletin before referred to, is probably as reliable as any data that can be given:

APPROXIMATE SHRINKAGE OF A BOARD OR SET OF BOARDS 100 INCHES WIDE, DRYING IN THE OPEN AIR.

VARIETY OF WOOD.	SHRINKAGE.
	Inches.
All light conifers (soft pine, spruce, cedar, cypress).....	3
Heavy conifers (hard pine, tamarack), honey locust, box elder.....	4
Ash, elm, walnut, poplar, maple, beech, sycamore, cherry.....	5
Basswood, birch, chestnut, horse chestnut, blue beech, young locust..	6
Hickory, young oak, especially red oak.....	Up to 10

SHAKES.

17. When large trees are converted into timber it sometimes occurs that parts of a board or plank separate from each other and become two pieces, and occasionally the wood is so "shaky" as to render it utterly useless as timber. This separation of the wood is due to "shakes" which are formed in the living tree.

These shakes are of two kinds: A. *Heart or star shakes*, which are splits or clefts occurring in the centre of the tree, as shown in Fig. 13. They are common in nearly every kind of tree, but unless the cracks are very large they do no great harm. B. *Cup shakes* or cracks separating one layer from another, as shown in Figs. 14 and 15. It has been commonly supposed that they are produced by the wrenching of the tree during heavy wind storms, but a recent English

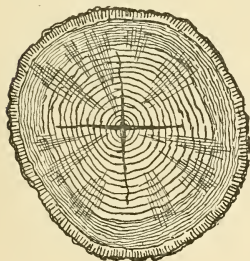

Fig. 13.

writer believes that they, and also the heart shakes, are produced by the expanding of the sapwood.

Cup shakes often injure oak, hard pine, mahogany, walnut and elm, and are the chief defect in hemlock timber. Trees less than 10 inches in diameter are not subject to shakes.

CONVERSION OF TIMBER.

18. *Bastard-Sawing*.—All boards and planks, except those intended for flooring, furniture or fine interior finish, are sawn from the

log by gang or circular saws, which cut the log into slices, as shown in Fig. 16, and the edges are then trimmed by a circular saw, the edgings being worked up into laths or used for kindling. Boards sawn from the log in this way are called "bastard-sawed." The

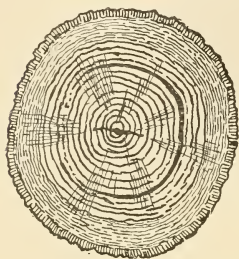

Fig. 14.

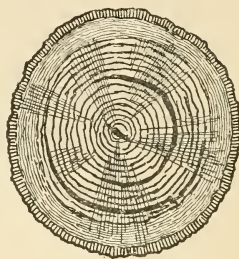

Fig. 15.

face of a bastard-sawed board, except on a few boards that are cut from the centre of the log, will generally have the appearance shown in Fig. 2, by which the manner of sawing can be readily determined. About 25 per cent. of the boards thus sawed which come from near the centre of the log will show the annual rings running across the

end of the board, and on the face the rings of spring and summer wood will appear as parallel lines, as shown on the edge of the board in Fig. 2. Such boards are commonly called "quarter-sawed,"\* and in some mills quarter-sawed boards are obtained by picking out these pieces.

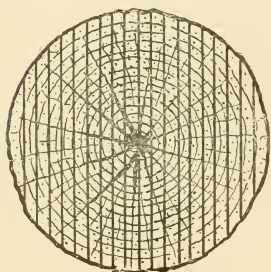

Fig. 16.

19. *Quarter-Sawed Lumber.*—Real quarter-sawed lumber, however, is obtained by first quartering the log and then sawing up each quarter at an angle of  $45^\circ$  with the diameter, as

shown in Fig. 17. In this way there is but little waste, and most of the boards are cut at right angles to the annual rings, and moreover

\*"The expressions quarter-sawed, rift-sawed, vertical-grained, straight-grained and edge-grained, as applied to manufactured wood, mean identically the same thing."—*Northwestern Lumberman*. When the lines of summer wood appear perfectly straight and parallel it is sometimes called "comb-grain."

the saw cuts often split the medullary rays, giving a handsome silver grain, as in quartered oak and sycamore. It is more trouble and takes more time to saw lumber in this way, and there is a little more waste; hence quarter-sawed lumber costs more than that which is bastard-sawed, but it possesses advantages which more than compensate for the extra cost.

At the present time hard pine is about the only soft wood that is quarter-sawed (except for clapboards), and the product is used almost exclusively for flooring.

Oak for flooring and finishing purposes is generally quarter-sawed, and many of the other hard woods are sawed in this way.

Quarter-sawed lumber wears better, warps and shrinks less, and in most hard woods looks handsomer than the bastard-sawed.

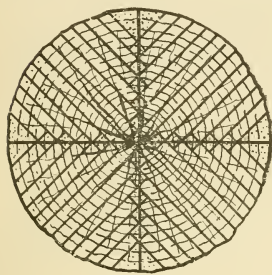

Fig. 17.

The finest furniture is now made of quarter-sawed lumber, the finest finishing is quarter-sawed, as is also the best clapboarding and the best flooring.

Framing timber, such as planks and dimension lumber, is almost invariably bastard-sawed when intended for building purposes.

For railway ties and the construction of cars and carts, the lumber is often sawn by first quartering the log and then squaring the quarters, so that in such lumber one edge of each piece is from the heart of the log. This is done to prevent checking and warping.

**20. Merchant Sizes.**—With a few exceptions framing timber is always sawn to even dimensions and lengths, as 4x6, 6x8, 10x12, etc.

Floor joist and planks are sawn 2, 3 and 4 inches thick, and 14-inch joist are usually also sawn 2½ inches thick. A few mills saw 15-inch joist, and in New England 5-inch studding and 2x7 rafters are common, but in the West odd widths are not generally carried in stock.

Outside and inside finishing wood of the common kinds are usually sawn 1, 1¼, 1½, 2 and 2½ inches in thickness. Flooring is usually sawn 1 and 1¼ inch thick, so as to finish to ¾ and 1¼ inch. Ceiling (or matched sheathing, as it is called in New England) is sawn to finish ¾, ⅝, ¾ and 7⁄8 inch in thickness.

The more expensive finishing woods are most generally used in ¾ and ⅝-inch boards and in *vencers*.

"A veneer is a thin strip cut from a board by a shaving machine, thirty veneers being allowed to each board of an inch thickness, the boards of the most costly woods running about 2 feet wide and 10 feet in length."

**Measurement of Lumber.**—Framing timber, planks and boards are always sold by "board measure," that is, the number of superficial feet the piece would contain if sawn into boards 1 inch thick. Matched flooring and ceiling are measured by the size of the board from which the flooring or ceiling is worked.

Boards less than an inch thick are measured by the square foot, the price depending upon the thickness. Veneers are always sold by the square foot. Lattice and mouldings are sold by the lineal foot, but the price of the latter depends upon the thickness as well as the width. Laths, shingles and clapboards are sold by the thousand.

Lumber of all kinds generally comes from the mill in even foot lengths, as 10, 12, 14, 16 feet, etc., and lengths between these measurements must be cut to waste.

#### STRENGTH OF TIMBER, AS AFFECTED BY ITS PHYSICAL CHARACTERISTICS.

21. The method of calculating the strength of timber under the different kinds of strains to which it may be subjected will be found fully explained in the "Architects' and Builders' Pocket Book," and will not be considered here. There are, however, certain variable conditions in timber which it is impossible to recognize in a formula, but which often need to be taken into account when it is desired to utilize the maximum strength of the wood. These conditions are not generally explained in the handbooks, and may appropriately be considered in a work of this character.

*Effects of Moisture.*—In making the "United States Timber Tests" on long-leaf Southern pine an actual moisture determination was made for every test of strength. Most of the tests were also made either in pairs or sets of three, the wood for each set being taken from the same tree and being as nearly identical as possible, with the exception that one piece was tested while green and another was seasoned before testing. These tests were so numerous and thorough that Professor Johnson considers that it may be stated as probably a universal fact "*that all kinds of timber are about twice as strong when thoroughly seasoned as they are in a green state.*"

"It has also been shown that the maximum strength corresponds to about 5 or 6 per cent. moisture, the strength at absolute dryness being somewhat reduced."



The moisture in fairly well-seasoned timber is about 15 per cent.

**22. Weight.**—*For any given species of timber, and for any given degree of dryness, the strength is almost directly proportionate to the weight.* This is considered to be due to the fact that the weight (for the same percentage of moisture) indicates the density, and consequently the proportionate number of fibres—that wood which has the most fibres would naturally be supposed to have the greatest strength.

*The strongest portion* of a young tree is the heart. The strongest portion of a very old tree is about midway between the heart and sap. The upper portion of a tree is also slightly weaker than the lower portion.

**Knots.**—The weakening effect of a knot is about as much in compression as in tension. Large knots should be regarded, therefore, as sufficient cause for the rejection of timber columns as much as for the rejection of timber beams.

“The best single test of timber is the test of a short column or the crushing endwise test.”

“There is no evidence that timber loses its strength from age or use alone,”\* although it is well known that little more than one-half the breaking load of a beam, if left on the beam continuously, will ultimately break it.

**23. Selection of Timber for Special Purposes.**—In selecting wood or timber for a special use that species should be chosen which appears to meet most fully the particular requirements of the case. Thus, for framing timbers, woods that are abundant and consequently cheap, and which can be obtained in large dimensions, are generally chosen, although in some instances extra strength and durability are more important considerations.

For outside finishing, ease of working and freedom from warping and checking are the principal requirements.

For wood that is to be buried in the ground in whole or in part, or to be used for piling, durability should be the chief consideration, although the question of cost must also often be considered.

For floors the wearing quality is the main consideration, while for fine interior finishing and cabinet work the color and grain of the wood generally control the choice.

The following list indicates those woods which are usually considered as best adapted to the particular requirements met with in building construction and finishing:

---

\* Professor J. B. Johnson, in Proceedings of the Twenty-third Annual Convention, A. I. A.

*For light framing*, for dwellings, tenement houses, etc.: Spruce, white pine, Northern yellow pine and hemlock give good satisfaction and are generally used on account of their lightness and cheapness.

*For posts, girders, truss timbers and heavy framing*: Georgia pine, Oregon pine or white oak are to be preferred. Next to these are the short-leaved Southern pine, Canadian red pine, or Norway pine, as it is often called, and the best qualities of spruce.

*For very long truss timbers and for flagstuffs, etc.*: Oregon pine and Georgia pine\* are about the only available woods; good-sized timbers of these woods can be obtained up to 60 feet in length.

*For outside finishing*: White pine, redwood or cypress should be used.

*For shingles*: Redwood, cypress, cedar and white pine, in the order named.

*For siding and clapboards*: Redwood, cypress and white pine are the best woods; spruce and Oregon pine are also used, but are not as satisfactory as the other woods.

*For posts and sleepers set in the ground*: White cedar, chestnut, redwood, cypress and black locust.

*For piles and cribbage*: Oak, elm, Southern hard pine, Oregon pine, Norway pine, cypress, spruce, white pine and hemlock, in the order given; only the first three should be used in salt water.

*For sash, solid doors*, as a base for veneers and for all joiners' work that is to be painted: Clear white pine gives the best satisfaction, although poplar (whitewood) is often used on account of economy; cypress is also well adapted for sash and solid doors.

*For thresholds and floors*, or wherever hardness and resistance to wearing is required: White oak, maple, Georgia pine, all quarter-sawed.

*For linen chests and closets*: Florida or Alabama red cedar.

*For interior finish*: Redwood, cypress and white pine and any of the hard woods are suitable. They are generally selected to please the especial taste of the owner, and all are sufficiently durable. Every hard wood needs to be thoroughly seasoned and kiln-dried, and all hard wood doors or sash should have a core of pine, covered with a  $\frac{3}{16}$ -inch veneer of hard wood.

#### DECAY OF TIMBER.

24. All wood is equally durable under certain conditions. Kept dry or submerged it lasts indefinitely, but under other conditions it may decay very rapidly.

\*The term "Georgia pine" in this work refers always to the long-leaf yellow pine.

The general causes of the decay in timber are the presence of sap, exposure to alternate wet and dryness, or to moisture accompanied by heat and want of ventilation.

Dryness and ventilation are the best preventatives of decay of timber used in general construction, and wood kept dry has been known to last for centuries, although it finally becomes brittle and loses its strength. Water also seems to act as a preservative, and some kinds of timber *constantly* immersed in water *not in motion* may endure for an indefinite period. Piles and cribbage resting on them are the only forms of building construction that come under this condition, and it is essential to their preservation that they be *entirely below the water line*, as nothing produces decay so rapidly as alternations of moisture and dryness.

"Rot in timber is decomposition or putrefaction, generally occasioned by damp, and which proceeds by the emission of gases, chiefly carbonic acid and hydrogen."

There are two kinds of rot to which the woodwork in buildings is subject, *dry rot* and *wet rot*. "The chief difference between them seems to be that *wet rot* occurs where the gases evolved can escape. By it the tissues of the wood, especially the sappy portions, are decomposed. Dry rot, on the contrary, occurs in confined places where the gases cannot escape, but enter into new combinations, forming fungi which feed upon and destroy the timber."

*Wet rot* occurs only when the wood is kept damp or is subject to alternate dryness and moisture, and cannot take place if the wood is once thoroughly seasoned and the absorption of further moisture prevented. Wet rot communicates itself to the sound portions of the wood only by actual contact, and if all the rotten wood is cut away and the balance of the timber kept dry it will not be further affected.

25. "*Dry rot* is generally caused by want of ventilation. Confined air, without much moisture, encourages the growth of the fungus, which eats into the timber, renders it brittle and so reduces the cohesion of the fibres that they are reduced to powder. It generally commences in the sapwood.

"An excess of moisture prevents the growth of the fungus, but moderate warmth, combined with damp and want of air, accelerates it. In the first stage of rottenness the timber swells and changes color, is often covered with fungus or mouldiness and emits a musty smell."\*

\* "Notes on Building Construction," Part III.

When the fungus first appears on the sides and ends of timbers it covers the surface with a fine, delicate vegetation, called by shipwrights mildew. These fine shoots afterward collect together, and the appearance may then be compared to hoar frost, and increases rapidly, assuming gradually a more compact form, like the external coat of a mushroom, but spreads alike over wood, brickwork, stone and plastering in the form of leaves, being larger or smaller, most probably, in proportion to the nutriment the wood affords. The colors of the fungus are various, sometimes white, grayish white, with violet, often yellowish brown, or a deep shade of fine rich brown.\*

The positions in which dry rot are most likely to occur are when imbedded solidly in damp plaster or masonry, as the ends of beams built into a wall, bottoms of posts imbedded in concrete, sleepers bedded in damp mortar or concrete, beams surrounded solidly with fireproof materials, beams in damp, close and imperfectly ventilated cellars, and wainscot or other finish fixed to damp walls.

Anything which absorbs moisture and confines it in contact with wood is likely to accelerate decay, particularly if accompanied with heat.

Wet or unseasoned lumber, covered with paint, tar, plaster, or any material which prevents the moisture from drying out, is quite sure to be attacked by rot. Sapwood is also more subject to decay than heartwood, and doubly so where the latter is protected by resinous substances, as in pine and cedar.

Dry rot is especially dangerous, in that it not only eats up the entire timber in which it originates, but the germs of the fungi producing it spread themselves to all adjacent woodwork without necessary contact between the affected and the sound wood. When dry rot is discovered the affected pieces should be immediately removed, if possible, and all adjoining woodwork thoroughly scraped and washed with strong acids and *provision made for thorough ventilation*. If the rot is on the outside of the timber, and has not penetrated far, it may be scraped away and treated with strong acids, and if kept well ventilated the rot may be stopped. Fortunately dry rot is not very prevalent in our Northern States, but in some of the Southern States great caution has to be exercised to prevent it.

**26. Preservation of Timber.**—For ordinary building construction the best means for preserving timber from decay is to have it thoroughly seasoned and well ventilated, and if these conditions are secured there will be little danger of rot.

For the majority of buildings designed by the architect it is prac-

---

\* "Notes on Building Construction," Part III.

tically impossible to obtain thoroughly seasoned lumber, but much can be done to secure ventilation.

Large beams and girders are better built up and cased, and posts should be bored longitudinally, as described in Section 15.

When built into masonry walls a space should be left around the timber to provide ventilation.

Wherever beams have to be enclosed air-tight it is desirable that some means of ventilation be provided if possible, particularly if the wood be not thoroughly seasoned or there is any chance of its becoming damp. In all outside woodwork care should be taken to form the joints so as not to afford a lodgment for moisture. All woodwork exposed to the atmosphere is generally protected by paint or oil, but they should not be applied while the wood is wet or damp, nor, if practicable, while it is green. All woodwork in contact with outside masonry should have the back painted.

Posts to be set in the ground should either be dipped in coal tar or else the parts to be buried should be charred. Timber that is to be used in sea water for wharfs, etc., and in places where it will be subject to moisture, but not kept constantly wet, such as piles and sleepers, should be impregnated with creosote under a pressure of from 30 to 40 pounds per square inch. There are several processes for preserving timber, but filling the pores with creosote is admitted to be equal to any, and for protecting wood against the teredo or ship worm it is at present admitted to be the most valuable process.

#### VARIETIES OF TIMBER USED IN THE UNITED STATES.—THEIR CHARACTERISTICS AND USES.

**27. A. Coniferous Woods.**—These woods include nearly all of the soft woods, and furnish nearly all of our framing timber and the larger part of that used for finishing.

**Pines.**—The pine is used more extensively for building purposes than any other kind of wood; it is the principal wood in common carpentry and also in heavy construction. It usually grows to a great height, with few branches and straight cylindrical stems, thus affording boards and timbers of considerable size and length. It also forms vast forests, which greatly facilitate cutting and shipping.

There are at least ten varieties of pine that are used for building purposes, but only the following are used to any great extent:

**Soft Pines.**—*Eastern White Pine* (*Pinus strobus*), also called "soft pine."—Obtained principally from Maine, Canada and the

States bordering on the Great Lakes. This tree was formerly the most important timber tree of the Union, furnishing the best quality of soft pine. The supply has been so far exhausted that this wood is now only used for finishing purposes, except in a few States of the North and middle West.

The wood, when of a good quality, is creamy white in color, soft and straight grained, light in weight, and is very easily cut. It contains very little resin, and is durable only in dry air. In transverse strength it is the weakest of all woods used in building, with the exceptions of hemlock and redwood. It also swells or shrinks seriously when the hygrometric state of the atmosphere changes greatly; on the other hand it possesses the advantages of being very straight grained, free from knots, and very easily worked. Its most valuable characteristic, however, is its freedom from warping and cracking in seasoning. It probably stays in place (stands) better than any other wood, and is the best wood to use for solid doors, sash or light framing of any kind. It is also the best base for veneered work, and is remarkably well adapted to patternmaker's use. It is the best of all the Northern woods for outside finish, when protected by paint, and is the most desirable wood for all kinds of joiner's work that is to be painted. The best qualities are so expensive, however, that white-wood and other woods are now often used as a substitute.

*Sugar Pine* (*Pinus lambertiana*).—A very large tree forming extensive forests in Oregon and California. It much resembles the white pine and is used for the same purposes, although its standing and working qualities are not quite equal to the Eastern pine. This wood is also used locally for framing purposes.

*Western White Pine*.—Two varieties of white pine grow to a considerable extent in the Rocky Mountain region. They are used locally for framing timber and sheathing, but are unfit for finishing, as they are very knotty and warp badly. In Colorado this wood is designated as "native pine." That which comes from New Mexico is of a slightly better quality, and is sometimes used for ceiling and outside finishing, but is greatly inferior to either the Eastern or sugar pine.

**28. Hard Pines.**—*Norway Pine* (*Pinus resinosa*) is found from Canada to the Pacific coast, but does not reach far south in the United States. In Canada it is very commonly known as red pine. It attains a height of from 70 to 80 feet, with a diameter of 2 feet at the base, the trunk continuing of uniform diameter for two-thirds of its length. The wood is fine grained and white with a reddish tinge,

somewhat soft, but quite strong and durable, its strength being about equal to that of spruce. It is used principally for framing timber.

*Southern Hard Pines.*—There are ten varieties of pine which grow in the Southern States, and which are popularly known as yellow pine, hard pine, pitch pine and Georgia pine. All of these varieties contain a considerable quantity of pitch, and all are heavier than the Northern pines. Of the ten varieties above mentioned but three are manufactured into lumber to any extent; these are:

*Georgia Pine*, or long-leaved Southern yellow pine (*Pinus australis*, *Pinus palustris*).—This is the wood generally referred to when "yellow pine" or "Georgia pine" is specified. It is the most valuable of all the Southern pines, both on account of its superior strength and durability and also on account of its large size, which enables very long timbers to be cut from it. This tree sometimes attains a height of 150 feet and a diameter of 4 feet. It has but little sapwood, and the heartwood is of very uniform quality, its resinous matter being very regularly distributed and the grain of the wood being very fine and close. Though not so tough and elastic as white oak, the long-leaved pine, especially that from Georgia, successfully rivals it in stiffness. "If a beam of each kind of timber, equal in dimensions, be supported at the ends, the oak beam will depart most from its 'mold,' but will break under about the same load."

This variety of pine is principally obtained from the States of Virginia, North Carolina and Georgia. It is almost the only wood used for building purposes in those localities, and is largely used throughout the Eastern and Middle States for heavy framing timbers, posts and girders. The wood is also much used for interior finish, for which purpose, however, it should be finished in varnish or hard oil, as it contains too much pitch to take paint well.

*Loblolly Pine* (*Pinus taeda*), known in the West as Texas pine.—This is the common lumber pine from Virginia to South Carolina, and is found extensively in Arkansas and Texas. It is a large-sized tree and forms extensive forests; often confounded with the long-leaf pine, but the wood is wider ringed, coarser, lighter, softer and contains more sapwood. Largely used for heavy framing timber in Texas and the States directly north; also used for interior finishing, but is not quite as handsome as the Georgia pine.

*Short-leaf Pine* (*Pinus echinata*).—Resembles loblolly pine, and often approaches in its wood the Norway pine. It furnishes the common lumber pine of Missouri and Arkansas.

**Effect of Tapping Pitch Pines.**—It has been generally believed, and is often found stated in books, that the tapping of pitch pine for turpentine is injurious to the strength of the timber. Recent tests made by the Forestry Division of the United States Department of Agriculture, however, have shown conclusively that this belief is erroneous. Not only is the strength not affected by tapping, but the chemical qualities are not changed, so that there is no reason whatever to believe that tapping in any way affects the durability of the lumber. Furthermore, the agent of the division, who had charge of the work, was unable to find a single person who could readily discern any difference between bled and unbled timber.

**Oregon Pine** (*Abies Douglasii*, *Pseudotsuga Douglasii*), sometimes called Douglass fir.—This tree really belongs to the spruce family, but as its wood more closely resembles that of the pine, it is most commonly known as Oregon pine. It is a noble tree, attaining a height of 300 feet and occasionally a diameter of 6 feet, and forming immense forests in the extreme Northwest of America. The wood is very variable, being usually coarse grained and heavy, with very pronounced summer wood, hard and strong, but often fine grained and light. It is largely used throughout the West for heavy framing, and is especially valuable for truss timbers, posts and for joist exceeding 24 feet in span.

Nearly all of the flagstaves at the Columbian Exposition were of this wood. From various tests that have been made in California on the strength and stiffness of this wood, it would appear to be about nine-tenths as strong and about five-sixths as stiff as the best long-leaf pine; it is much lighter in weight, however, and easier to work.

The wood is also used for siding, and to some extent for finishing lumber, but for these purposes it is greatly inferior to the Eastern or sugar pine, or to redwood. Most of the Oregon pine found in the Western markets is shipped from Washington, and it is often sold under the name of Washington fir. It is seldom carried in stock east of the Rocky Mountains on account of the high price of the timber due to the long haul.

**29. Spruce.**—There are three varieties of spruce used for building purposes in the United States. There is very little difference between them, and all three varieties are sold under the common name of spruce.

*The White Spruce* (*Abies alba*) is the variety most generally found in the lumber yards of New England. The wood is of a whitish color, light in weight, soft, stiff, moderately strong, contains little



resin, has no distinct heartwood and very much resembles white pine. It warps and twists much more than pine, and is on that account not a good wood for posts, girders and truss timbers. It makes excellent floor joist and studding, however, and is more largely used in New England for framing than any other wood, but cannot be obtained in very great lengths or large sizes.

Next to the Southern hard pines, and the Oregon and Norway pines, the author considers the spruce the best framing timber that we have.

Spruce is also largely used in the Eastern States for flooring and siding or clapboards, and for dressed sheathing, laths, furring stock, etc.

A poorer variety of white spruce is also found in the Rocky Mountains, but is only used locally.

*The Black Spruce (Abies nigra)* grows principally in Lower Canada and the rougher portions of the Northern States. Its wood has the same appearance as that of the white spruce, the difference in color being only in the bark and leaves. The black spruce is said to produce the largest and best timber.

*The Red Spruce (Abies rubra)*, or Newfoundland red pine, as it is sometimes called, grows in the northeast portions of North America, and furnishes a timber of about the same quality and size as the black spruce.

**Hemlock (*Abies canadensis*).**—This is a variety of spruce or fir found all along the northern boundary of the United States and in Canada; trees medium to large size. The wood is of a light reddish-gray color, free from resin ducts, moderately durable, commonly cross grained, rough and splintery, and holds nails firmly. It is used largely in New England for small scantlings and sheathing (or boarding, as it is called there); it is very liable to cup shakes, which greatly injures it for framing timbers.

Another variety of hemlock abounds in the Puget Sound region, where it is sold under the name of "Alaska pine." The tree is larger in size, and the wood is claimed to be heavier and harder than the Eastern variety and of superior quality.

**30. Cedar.**—A light, soft wood, stiff, but not strong, of fine texture and a grayish-brown or red in color. The wood seasons rapidly, shrinks and checks but little, and is very durable. Used largely for posts, ties and sleepers, and in building construction for shingles.

There are four varieties of white cedar in the United States, the

trees being generally scattered, and seldom forming forests. These trees are used principally for making posts, ties and shingles.

*The Canoe Cedar (Thuya gigantea)* (red cedar of the West) grows to a very large tree in Oregon and Washington, and, besides furnishing great quantities of shingles, it is quite extensively used in the State of Washington for outside finishing.

It makes the best of siding and mouldings and other work that is to be painted. As an interior finish it is not so good, although it has been much used for this purpose. It has a well-marked grain and takes a good natural finish, but, being soft, it is easily marred, and grows dark with age. It is much used for making sash and doors. The latter are found to be equal to the best white pine stock doors and are sold at the same price.\*

*Florida or Alabama Red Cedar (Juniperous virginiana)*; a small tree found on dry, sterile, rough country. The color of the heartwood is red, while that of the sapwood is white. The wood has a strong characteristic odor and a bitter taste, which preserves it from the attacks of insects, especially moths, and on this account it is used largely in fitting up linen chests and closets, drawers, etc. It is a very expensive wood, and is generally used in thin boards and veneers.

**Redwood** (*Sequoia sempervirens*).—This tree, which belongs to the cedar family, is found only in California and the Sierra Nevada Mountains, where it grows to an immense size.

The wood is very straight grained, soft, free from knots, and can be obtained in very wide pieces. The grain is very coarse and the color a light red, turning to brownish-red on exposure. It has a handsome appearance when polished, but is so soft that it mars very easily, and it is difficult to work without breaking the edges. On this account it is not likely to be popular for inside finish, although otherwise it is well adapted for such use.

Redwood possesses two very distinct peculiarities, which make it very valuable for certain purposes. The most important of these is its resistance to fire, which is very remarkable in a wood. It catches fire very slowly, and will not burn except under the most favorable conditions. Owing to this fact, and also to its abundance, about 95 per cent. of all the outside walls of all the ordinary buildings in San Francisco are covered with redwood siding and the roofs with shingles. The other peculiarity of this wood is that it shrinks or swells less than any other wood and seems to last longer in wet and damp places than other woods. In San Francisco it is used for the

\* Mr. George W. Bullard, Proceedings American Institute of Architects. 1895, p. 99.

foundations of houses and for the basements and sub-basements of five and six-story wooden buildings, of which the city is largely composed.

Outside of California redwood is used principally for shingles, for which it is probably the best material that we have, and for siding, ceiling and shelving, and to a limited extent for inside finish. Owing to the cost of transportation, it can hardly compete in the East with other and better woods, except for shingles.

**31. Cypress** (*Taxodium distichum*).—The cypress is a large deciduous tree occupying much of the swamp and overflow land along the coast and rivers of the Southern States. "There are numerous species of cypress, and as many qualities as there are species, that grown near the coast of the Gulf of Mexico and being known as Gulf Cypress being admittedly the best."

The wood is soft, light, straight grained, free from knots and easily worked, and is imperishable where covered with water. Its color is somewhat like that of olive wood, though it is not as fine grained nor as handsome. It makes a very pretty finish, however, when varnished and rubbed down. This wood is very durable and especially adapted for use in damp situations, such as for shingles, siding, eaves troughs or gutters, water tables, sills, sleepers, etc., and for tanks, tubs and vats. It appears to be less injuriously affected by damp than any other wood except redwood or cedar. It also possesses the quality of not warping to any extent, and it is claimed that for making sash, doors and blinds it is equal to white pine. It probably makes the most durable shingle, as there are instances where cypress shingles have been in continued use for 100 years. It can be obtained in wide, clear boards, and is excellent for pantry fittings, etc. If it were not for its softness it would make one of the best finishing woods. It is cheaper than clear pine, except in the very Northern and Western States.

**32. Broad-Leaved Woods.**—*Ash*.—Wood heavy, hard, strong, stiff, quite tough, not durable in contact with soil, straight grained and coarse in texture. The finished wood very much resembles bastard-sawed oak, except that the grain is much coarser and the wood more porous. It shrinks moderately, seasons with little injury, stands well and takes a good polish.

In buildings ash is used principally for inside finishing, stairs and cabinet work. It is also extensively used in the manufacture of furniture and the construction of wagons, farm implements, etc. It is about the cheapest of the hard woods, is easier to work than oak,

and when thoroughly kiln-dried can be used for making solid doors.

While there are six varieties of ash in the United States, but two varieties are known in the lumber markets, viz., *white ash* and *black ash*. The wood of the former has about the same color as white oak, while the black ash is of a brown color. The difference in the grain is not recognizable.

"The trees of the several species of ash are rapid growers, of small to medium height, with stout trunks. They form no forests, but occur scattered in almost all our broad-leaved forests."

**Oak.**—"The oaks are medium to large-sized trees forming the predominant part of a large portion of our broad-leaved forests, so that these are generally 'oak forests,' though they always contain a considerable proportion of other kinds of trees. Three well-marked kinds, white, red and live oak, are distinguished and kept separate in the market. Of the two principal kinds white oak is the stronger, tougher, less porous and more durable. Red oak is usually of coarser texture, more porous, often brittle, less durable and even more troublesome in seasoning than white oak. The red oaks everywhere accompany the white oaks, and, like the latter, are usually represented by several species in any given locality. Live oak, once largely employed in ship building, possesses all the good qualities (except that of size) of white oak, even to a greater degree. It is one of the heaviest, hardest and most durable timbers in this country, but is now too expensive to use for building purposes."

The wood of white oak is light straw color; that of red oak is tinged with red, the difference in the color of the woods being increased by varnishing. Both the white and red oak shrink and crack badly in seasoning, and all finishing lumber should be thoroughly kiln-dried, after which it stands well.

Both kinds are extensively used for inside finishing, cabinet work and furniture.

When used for doors the wood should be sawn into veneers not exceeding  $\frac{3}{8}$  inch thick and glued to a pine core. The silver grain in oak is obtained by quarter-sawing. White oak is also largely used for finished flooring in dwellings, for which purpose it should be quarter-sawed and cut into strips not exceeding  $2\frac{1}{4}$  inches on the face. It is also occasionally used in construction for posts and bolsters, or where hardness or stiffness are required, but its high price is limiting its use in construction every year.

For finishing purposes red oak answers practically as well as white oak, and at the present time is sold at the same price. The two

varieties should be used separately, however, as when finished there is a pronounced difference in their color.

**33. Beech.**—A medium-sized tree, common, sometimes forming forests; most abundant in the Ohio and Mississippi basin, but found from Maine to Wisconsin and southward to Florida.

The wood of the beech is heavy, hard, stiff and strong, of rather a coarse texture and white to light brown in color. It shrinks and checks considerably in drying, but works and stands well and takes a good polish. The beech is used for furniture and flooring, and to a limited extent for inside finishing.

**Birch.**—The birches are medium-sized trees, forming extensive forests northward and occur scattered in all broad-leaved forests of the Eastern United States.

The wood is heavy, hard, strong and of fine texture; the sapwood is whitish in color, the heartwood in shades of brown with red and yellow. It is very handsome when finished, takes a good polish and has a satiny lustre; shrinks considerably in drying but works and stands well.

Birch is now quite extensively used for inside finishing, and is one of our handsomest hard woods. The figured North Carolina birch ranks among our most expensive native woods.

The banquet hall of the Auditorium Hotel in Chicago is finished in birch.

Birch is often used to imitate cherry and mahogany, the grain of these woods being much the same.

Two varieties of birch are distinguished in the market: red birch and white (canoe) birch, the wood of the latter being lighter than that of the red birch.

**Butternut (White Walnut).**—A medium-sized tree, largest and most common in the Ohio Basin, but found from Maine to Minnesota and southward to Georgia and Alabama. The wood is very similar to black walnut, but lighter and of a light brown color, quite soft and strong. It stands well, works easily and is well suited for inside finish, its cost, as a rule, being a little less than that of the other hard woods excepting ash.

**34. Cherry.**—The lumber-furnishing cherry tree of this country is the wild black cherry, a small to medium-sized tree scattered through many of the broad-leaved woods of the western slope of the Alleghenies, but found from Maine to Florida and west to Texas.

The wood is heavy, hard, strong, of fine texture; sapwood yellowish-white, heartwood reddish to brown. It shrinks considerably, but

works and stands well, takes a good polish and is much esteemed for its beauty. Used principally for fine interior finish, cabinet work and furniture; often stained to imitate mahogany. It cannot be obtained in wide boards, and, the grain being fine, it is most suitable for work that is much cut up or moulded.

**Chestnut.**—A medium-sized tree very common in the Alleghenies and in some portions of New England. The wood is light, moderately soft, stiff, not strong and of a coarse texture, resembling ash; the sapwood light, the heartwood darker brown. It shrinks and checks considerably in drying, but works easily, stands well and is very durable. Used locally for interior finishing and also for railway ties, sleepers and heavy construction.

**Elm.**—A medium to large-size tree found scattered in all the broad-leaved forests of this country, and sometimes quite abundant. The wood is heavy, hard, strong and very tough, moderately durable in contact with the soil; commonly cross grained, difficult to split and shape, warps and checks considerably in drying, but stands well if properly handled and is capable of a high polish. The heartwood is of a brown color with shades of gray and red; texture coarse to fine. Elm has only been used to a slight extent in buildings, but its use for interior finish is gaining; much of the wood has a beautifully figured grain, and it is used in the manufacture of all kinds of furniture. The wood appears to be well adapted to staining where colored effects are desired.

**35. Gum.**—There are two varieties of this wood, the "sour" gum and the "sweet" or red gum. The latter is the variety most commonly seen in furniture and buildings. The sweet gum is a large-sized tree, very abundant in the South. The wood is rather heavy and soft, quite stiff and strong, tough, commonly cross grained but of fine texture; the heartwood is reddish brown in color. The wood shrinks and warps considerably, and has a bad reputation in this respect, but by proper handling can be made to stay in place as well as other woods. It is rather a handsome wood and is much used in the manufacture of mantels, cabinet work and furniture.

It is also used locally for framing timber; in some portions of Kentucky it is the common framing lumber.

**Maple.**—There are several varieties of maple in the United States, but most of the maple in the market comes from the *sugar* maple (hard maple, rock maple), which is most abundant in Minnesota and in the region of the Great Lakes.

The wood is heavy, hard, strong, stiff and tough, of fine texture and

frequently with a wavy or "curly" grain; creamy white in color, with shades of light brown in the heart.

It shrinks moderately, seasons, works and stands well, wears smoothly and takes a fine grain. The curly, or bird's-eye maple, is one of the handsomest of our hard woods, and at the present time is extensively used for fine interior finishing; it seems to be particularly appropriate for the finish of chambers, and some of the handsomest chamber sets are made of maple. The curly maple has to be selected and costs more than the plain maple.

**36. Poplar or Whitewood.**—The lumber commonly known by these names comes principally from the tulip tree, which is often called yellow poplar. It is a large tree, quite common in the Ohio Basin and in some portions of the South.

The wood is usually light, quite soft, stiff but not strong, of fine texture and remarkably free from knots; the color varies from almost white to a pale yellow.

It is extensively used in the Eastern and Middle States for inside finish of the cheaper grade, cabinet work and turned posts. It is also especially adapted for shelving, as it can be obtained in very wide boards entirely free from knots.

Whitewood can be finished in its natural color, but is generally stained in imitation of cherry or some other close-grained wood, and when skillfully done it is difficult to detect the imitation. On account of its close grain and great lateral cohesion of its fibres, it is well adapted for carving that is to be painted.

The wood shrinks considerably in seasoning and warps badly. A solid door of whitewood is quite sure to warp or spring unless made of thoroughly seasoned and kiln-dried lumber. For first-class work whitewood doors should be made by veneering on a pine core, as is done with hard woods.

**Sycamore.**—A large tree, of rapid growth, common and largest in the Ohio and Mississippi valleys, but found in nearly all parts of the Eastern United States. The wood is moderately heavy, quite hard, stiff, strong, tough, usually cross grained, of coarse texture and white to light brown in color. It is hard to work, shrinks moderately, warps and checks considerably, but stands well when properly treated. It is a handsome wood and is used considerably for finishing lumber.

**Black Walnut.**—A large tree, with a stout trunk, formerly quite abundant throughout the Allegheny region; occurs from New England to Texas and from Michigan to Florida. The finest figured walnut trees are found on the slopes of the Blue Ridge and Cumber-

land Mountains. The wood is heavy, hard, strong and of coarse texture; the narrow sapwood is white, the heartwood chocolate brown. It shrinks moderately in drying, works and stands well, takes a good polish and is exceedingly well adapted for inside finish and furniture. At one time it was in great demand for this purpose and is again coming into favor. It is now used principally in the form of thin stuff and veneers. The finer grades of walnut have a beautiful figure and are carefully selected before cutting; they are sold chiefly in the form of veneers and used in the manufacture of furniture.

#### IMPORTED WOODS.

37. A great variety of fine woods are brought into this country each year for interior finishing and furniture work. Of these, mahogany, French burl, rosewood, Circassian walnut and satin wood are the most common, although all are very costly and hence used only for the best grades of work.

*Mahogany* is the only imported wood much used for the finish of buildings. The heartwood is of a light red color with a handsome grain, and at the present time is the most popular wood for fine interiors, both public and private. The wood is peculiarly marked with short, straight lines or dashes, by which it can be distinguished from other woods stained to imitate it.

The mahogany now used in this country comes principally from Mexico and Cuba. Formerly large quantities were shipped from St. Domingo and Honduras, but wood from these localities is now seldom seen. The Honduras variety was designated by the term *baywood* to distinguish it from the St. Domingo or *Spanish* mahogany, and the same term is now used to designate the soft and inferior grades that come from Mexico. There is a great difference in the color of the Mexican mahogany, some pieces being almost white in places, while other pieces are of a deep red color. All of it turns darker in color when finished, and also with age. The wood is shipped to this country in logs and is then sawn into boards or veneers by the importers. The finest Mexican mahogany is called "Frontera," from the name of the shipping place. Mahogany is too expensive to use in large pieces and is principally used in the shape of veneers. When a superior piece of work is required, figured or selected mahogany of a uniform dark color should be specified. Mahogany is easily worked and takes a high polish. There is no wood that stays in place better when thoroughly dried and glued.



*White Mahogany* (*Prima vera*) has about the same grain as the real mahogany, but is of a creamy white color. It is obtained from the west coast of Mexico, and ranks among the more expensive woods.

*Satin wood* and *French burl* are among the most expensive woods and are used for finishing only in the finest buildings. Satin wood comes from the West India islands and French burl from Persia. The latter is really a walnut, the burl being a wart or knot that forms on the side of the tree while it is young. Circassian walnut comes from the Black Sea.

**38. Market Prices of Various Woods.**—The price of woods of all kinds varies not only with the locality but also with the condition of business, and is often controlled by "combinations" of the lumber dealers. The following prices, therefore, should be considered as comparative only:

*Framing Timber.*—In nearly all localities framing timber of medium sizes and lengths can be bought for about \$16 per thousand feet (M); large sizes and lengths over 16 feet generally cost from \$2 to \$4 per M more.

*Georgia Pine* costs about \$25 per M in Boston, \$20 in New York, \$22 to \$25 in Philadelphia and Chicago, \$20 in Kansas City, \$25 in Denver and \$15 in the South.

*Oregon Pine* costs about \$15 on the Pacific coast, \$32 in Denver.

*White Pine* for finishing costs from \$25 to \$80 per thousand, according to quality; *whitewood*, east of the Rocky Mountains, varies from \$25 to \$50; *cypress* costs from \$28 to \$40; *redwood* boards, of the best quality, cost at the present time in Denver \$50 per M.

The hard woods used for interior finishing now sell at the following prices in New York City: Mahogany, 16 to 18 cents (per foot); white mahogany, 18 to 20 cents; red birch, 4 cents; cherry, 8 to 12 cents; quartered oak, 9 cents; black walnut, 10 cents; maple, 5 cents; ash, 3½ cents; English brown oak (imported), satin wood and Circassian walnut sell at about 50 cents per square foot each.

CHAPTER II.

WOOD FRAMING—ORDINARY  
CONSTRUCTION.

---

Although it is not necessary for the architect, draughtsman or superintendent to be able to lay out the frame of a building, cut the timber and put it together, it *is* necessary that he should have a thorough knowledge of the way in which it should be done, and how all the joints or connections should be made, as otherwise he can not be sure that the work is done as it should be.

In the Eastern States it is customary for the architect to show the complete framing of wooden buildings by a separate set of drawings, and to make separate framing plans for the floors and roofs of brick buildings, but in the West the framing is often left to the care of the builder, the sizes of the timber being specified and the direction the floor joists are to run being indicated by dotted lines on the plan. Such a practice should be discouraged, as it is much better for all concerned that a complete set of framing plans be furnished by the architect.

The young architect should also bear in mind that the courts invariably hold the architect responsible for the safety of the building, as far as it depends upon the plans and specifications, and hence nothing of importance should be left to the discretion of the builder, unless perchance he is one in which the utmost confidence may be placed.

**39. Framing Timber.**—*Technical Terms.*—To design the framing of a building in a practical and economical manner, it is necessary for the architect or draughtsman to be familiar with the kinds of wood used for framing in the locality in which the building is to be built, and their relative cost, and also with the commercial sizes to which lumber is sawn. Information on these points is given in Sections 20, 23 and 38, but it should be supplemented by inquiries of local contractors or lumber merchants.

The various pieces of timber used in framing buildings have distinguishing names with which it is also necessary to be familiar; thus, floor beams are called "joists," the pieces which support the

roof boarding are called "rafters" and the uprights in a wooden wall or partition "studding" or "studs."

Beams which support the floor joists between walls or partitions are called "girders," and similar beams under the rafters of a pitch roof are called "purlins." Small timbers, such as 2x4 inches, 2x6 inches, 3x4 inches, 4x4 inches, etc., are sometimes called "scantlings." Pieces 4x6 inches and over in cross section are almost always designated as "timbers."

There are also various other names for timbers used in special positions, which will be mentioned in describing the construction of which they form a part.

40. *Sizes.*—Floor joists, rafters and studding are commonly made 2 inches thick, the depth depending upon the span of the joists or rafters or the height of the studding.

As the strength of a rectangular beam increases as the *square of the depth* and only directly as the breadth, it is more economical of material to use a deep beam rather than a thick one. Thus, for the same span a 2x10-inch joist has the same strength as a 3x8-inch or 5½x6-inch joist, but it contains less lumber. The deeper beam is also much stiffer, the stiffness being in proportion to the *cube* of the depth, so that a 2x10-inch and a 3¾x8-inch beam have the same stiffness (other conditions being equal), although the latter contains 55 per cent. more lumber than the former. When the depth of a joist exceeds 12 inches, however, the thickness should be increased to 2½ or 3 inches, as a 2x14-inch joist is liable to fail by buckling sideways.

Large timbers are generally made more nearly square, for the reason that it is difficult in most woods to get great depth with 6 or 8 inches in thickness; hence, for girders and purlins, 8x10 inches, 10x12 inches and 12x14 inches are common sizes; 16-inch timbers are seldom used, although they can sometimes be obtained. Posts, on the other hand, should be either round or as nearly square as the conditions will permit, the square post being the most economical section for timber.

#### OUTSIDE WALLS OF WOODEN BUILDINGS.

41. In the framing of the walls of wooden buildings two distinct methods may be followed; these are distinguished by the terms "balloon" framing and "braced" or "old-fashioned" framing.

*The braced, or full frame*, as it is sometimes called, was the only kind in vogue previous to about the year 1850. In this method of

framing the sills, posts, girts and plate are made of heavy timbers, and are all mortised and pinned together and also braced by 4x4 or 4x6 timbers, mortised and pinned to post, sill and girt. The common studding is also mortised to the sills, girts and plate. To frame a building in this way it is necessary to cut all the pieces and make all the mortise holes on the ground, and then fit them together and raise a whole side at a time, or at least one story of it.

In Colonial days the posts and girts were often made of hewn timbers 8 and 10 inches square, so that they projected into the rooms, and it required a great many men to raise the walls when the fitting was completed.

The braced frame, when carefully fitted and pinned, is very substantial and is much more slow burning than the balloon frame, and vermin cannot go through the walls from one story to another. It is also very difficult to "rack" such a frame, and all posts must be plumb and parallel or the braces will not fit.

**The Balloon Frame** is composed of much lighter pieces, and is more quickly erected and at much less expense. The method of procedure in erecting a balloon frame is to first lay the sill, which is generally 4x6 inches, halved together at the angles, and after the floor is laid the corner posts, which are generally 4x6, although sometimes 4x4, are set up and secured temporarily in place by means of "stay laths," or pieces of boards nailed diagonally to post and sill. The common or filling in studding are then set up, with their lower ends spiked to the sill, and stayed in place by nailing a board temporarily across the studding on the inside. The filling in pieces extend the whole height from sill to plate, and the second floor joists are supported by notching a 1x7 board, called a false girt or ribbon, into their inside edge at the proper height to receive the joist. The ends of the joist are also placed against a stud, wherever practicable, and spiked to it.

After the second floor is on, the top of the studding is cut to a line and a 2x4 spiked on top, and then another 2x4 on top of that, the two pieces always breaking joint. If the common studding comes in lengths that will not reach to the plate they are spliced out with short pieces set on top and the joint "fished" by nailing short pieces of boards on each side.

Fig. 18 shows a portion of the framework of a two-story house constructed in the manner described above. In the better class of buildings the frame is braced at the corners by means of 1x6 boards, let in flush with the outside of the studding and nailed at each inter

section with two or three ten-penny nails, as shown in the figure. In many cheap buildings these braces are omitted, but unless the sheathing is put on diagonally they should always be used. In the balloon frame the timbers are held together entirely by nails and spikes, thus permitting the frame to be rapidly put up. For the timbers and studding thirty and twenty-penny spikes should be used, and for the 1-inch stuff ten-penny nails. Cut nails are to be preferred, as they hold better than wire nails.

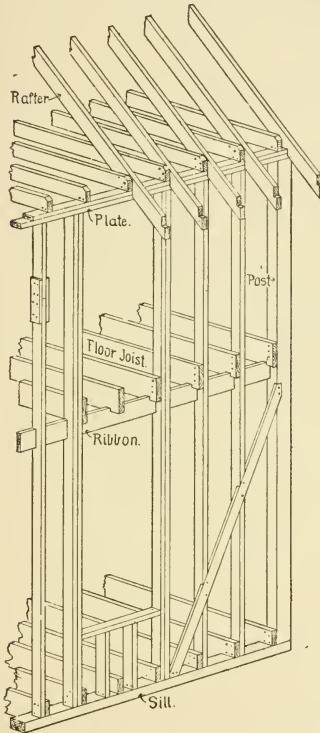

Fig. 13.

houses built to sell, and is the general method in vogue in the Northwest. Such a frame, however, is less rigid than the braced frame and is more quickly consumed by fire.

**42. Combination Frame.**—The better class of wooden buildings are now framed on a sort of combination of the balloon and

In both methods of framing the studding is doubled each side of the window and door openings. In the balloon frame it is necessary that the double studs shall extend the full height of the wall, and hence it is desirable to have the windows in the second story directly over those in the first story. In the full frame, however, the common studding only extends the height of one story, and it makes no difference in regard to the construction where the windows are placed.

The balloon frame is much cheaper than the braced frame, and as it is concealed when the house is sheathed and plastered, balloon framing is generally employed for



43. **Dimensions and Details.**—*Sills.*—Where the sill rests on a brick or stone wall, and the cellar openings are narrow, a 6x6 sill answers very well, but if the sill rests on posts, or there are wide openings beneath, the sills must have sufficient strength to support the walls and floors above the opening. It should also be remem-

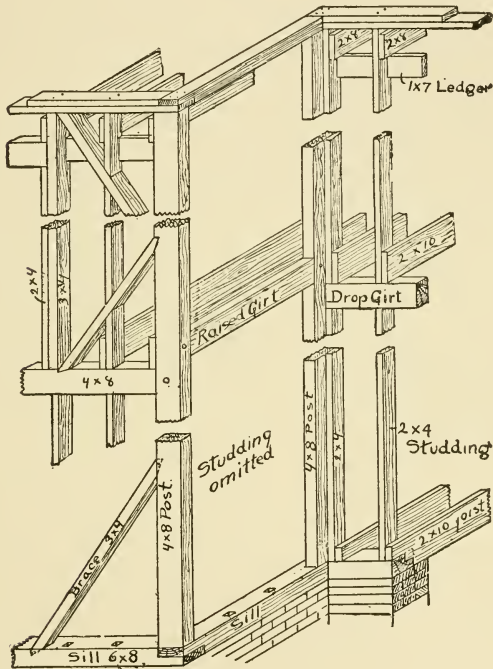

Fig 20.

bered that in this method of framing a good deal of the sill is cut away by mortising, as shown in Fig. 21, thereby greatly lessening its strength. In all large or heavy buildings the sill should be at least 6x8 inches and laid with the board side on the wall.

The sills should always be imbedded in cement mortar and should set in at least 1 inch from the outside face of the wall. They should

be halved and pinned at the angles\* and wherever splices occur, but when practicable they should be in one length from angle to angle; they must, of course, extend all around the house. In commencing the frame of a wooden building the sills are the first timbers to be cut and put in place.

If the basement is 5 feet or more above grade, the sill should also be bolted to the masonry by  $\frac{3}{4}$ -inch bolts 30 inches long, solidly bedded in the wall and extending through the sill, with the nut turned up tight. The sills of buildings having the first story of brick or stone should also be secured in this way.

*Studding.*—For frame buildings of medium size 2x4-inch studding is almost invariably used; for churches, schools, etc., 2x5 or 2x6 studding should be used. In the cheaper class of buildings the studding is generally set 16 inches on centres, but a much better

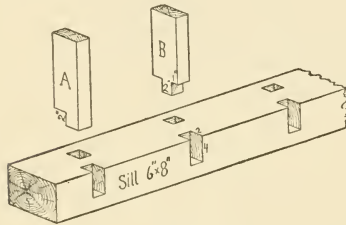

Fig. 21.

building is obtained if the spacing is made 12 inches. All studding for buildings that are to be plastered should be sized, by passing through a planer, to a uniform width. The lower end of the studding should be mortised into the sill, either as shown at *a* or at *b*, Fig. 21; the latter method is the better of the two and

should always be used for 5-inch or 6-inch studding.

44. *Posts, Girts and Braces.*—One dimension of these pieces is always governed by the width of the studding. When 4-inch studding is used the posts may be 4x6 or 4x8 inches, the girts 4x8 inches and the braces 3x4 inches. For wider studding the thickness of the posts and girts must be the same as the width of the studding. The posts at interior angles should always be 2 inches wider in one dimension than in the other to give a nailing for the sheathing.

The connection of the girts with the post should be made as shown in Fig. 22, and the braces should be mortised and pinned as shown in Fig. 23, although they are too often merely spiked. All pins used in framing should be made of hard wood and should be  $\frac{3}{4}$  inch diameter for girts and  $\frac{3}{8}$  inch for braces.

\* In New England the sills are often mortised and tenoned at the angles, but it is doubtful if any particular advantage is gained thereby unless the sills are very large.



When the attic floor joists come a short distance below the plate they are usually supported on a 1x7 board, called a "ledger board," "ribbon" or "false girt," let into the studding, as shown in Fig. 20. When there is a wide opening in the second story, however, a solid girt must be substituted, as shown in Fig. 19, to provide sufficient strength to support the floor and roof. Where there is room, it is desirable to truss over all openings exceeding 4 feet in width.

*Plate.*—If the attic joists rest on top of the plate, then the plate cannot be wider than the studding unless it projects on the outside, but if the plate is above the attic joist, as in Fig. 20, a wider plate may be used, say 4x6 inches; the wider the plate the greater is the resistance offered to the thrust of the rafters and the consequent springing of the wall. Whatever size is used, it is better to build the plate up out of pieces 2 inches thick, spiked together, than to use solid timber, as the built up plate will warp or twist less and can be more strongly spiked, and the joints more firmly spliced.

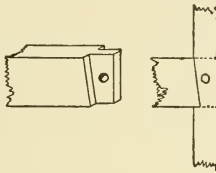

Fig. 22.

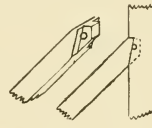

Fig. 23.

**45. Laying Out.**—The framing of the outside walls of a wooden building is generally shown by a set of elevation drawings showing each side of the building in the manner illustrated in Fig. 19. In making these drawings the draughtsman will find that the work can be more easily and quickly done by drawing them on the dull side of tracing cloth or paper laid over the finished elevations. The sills, posts, girts and plates should first be drawn, then the studding framing the door and window openings, next the braces and lastly the filling in studding. The latter are often indicated by a single line.

The sizes of all special timbers should be carefully marked on the drawings, and the location of the *centre* of all openings should be given. The size and height of the window openings is best designated by giving the size of the glass and the height of the finished stool above the floor, as shown in Fig. 19. The height of the plates and girts should also be correctly given, and the pitch of the roof in terms of rise to run.

In locating the braces it should be remembered that a brace is most effective when at an angle of  $45^\circ$ , and should be connected with the post at from one-third to one-half the height of the story. Every dimension necessary for the complete construction of the frame should be found on the framing drawings.

No drawings that an architect has to make require greater thought and exactness than the framing plans, for upon them depend the proper construction of the building and often its safety, and moreover any error in the figures generally leads to considerable expense through waste of material and labor, and for any such expense the architect is in most cases responsible.

### FLOORS.

**46. Wooden Buildings.**—The floors of wooden buildings are usually constructed of 2-inch planks called "joists," which are set on edge and spaced either 12 or 16 inches apart from centres. These joists are supported, in the first floor, by the sills at the outer ends and by a wooden girder or brick wall near the middle, the girder or wall being generally placed directly under the "bearing partitions" in the first story.

The second floor joists are supported by the girts at the outer ends (as shown in Figs. 18 and 20) and by the partitions in the centre of the building.

The attic floor joists may either rest directly on the wall plate, as shown in Fig. 18, or on a false girt, as shown in Fig. 20, according to the design. The inner ends of the joists are supported by the second story partitions.

In a one-and-a-half-story house the attic joists are supported at their outer ends by being spiked to the sides of the rafters.

*Sizing and Crowning.*—The first step toward framing the floors is the sizing and crowning of the joists. For spans of 16 feet or over all floor joists should be crowned or the top dressed to the arc of a circle, with a rise of  $\frac{1}{4}$  of an inch in the centre for every 16 feet of span. This must be done by hand with a hatchet and plane. The ends of the joists are then sized, so that the distance from the bearing to the top of the joist will be the same in each beam, thus insuring an even surface on top. Ordinary timbers often vary  $\frac{1}{4}$  to  $\frac{1}{2}$  an inch in size, and if they were not sized at the ends their tops would not be in the same plane. The object of the crowning is to offset the inevitable deflection or sagging of the joist, and thus secure a level floor.

In the Eastern States the bottom of the floor joists is almost always cross-furred with  $1\frac{1}{2}$ -inch strips, so that any irregularity in the depth of the joists is easily overcome. In many of the Western States, however, this is very seldom, if ever, done, and all the joists have to be dressed to a uniform width, if they do not come so. A little irregularity in a ceiling can be overcome in plastering.

*The spacing of the floor beams* should not exceed 16 inches from centres, and, where the ceilings are not furred, it is better to space them 12 inches from centres.

**47. Details of Framing.**—*Framing of Joists to Sill.*—The connection of the floor joists to the sill should be such that the sill will support the joist and without weakening the latter more than ab-

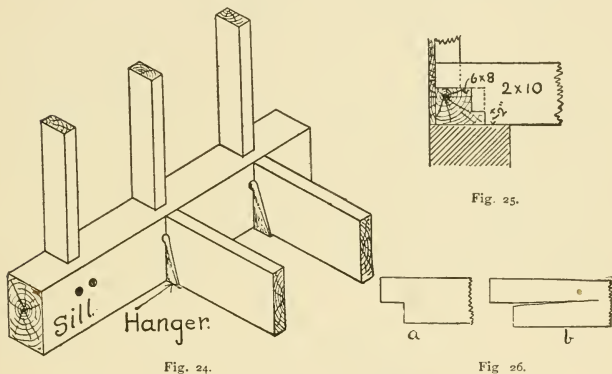

solutely necessary; then if the foundation wall settles the joists will not move unless the sill does.

The ideal connection of joists and sill is by hanging the joists in a Goetz or Duplex Hanger, as shown in Fig. 24. This retains the full strength of the joist and suspends it securely from the sill.

The next best method, and the one more generally employed, is shown in Fig. 25. In cheap buildings, where only 4x6 sills are used, the floor joists are often cut as at *a*, Fig. 26, and the sill is not mortised. This is very poor construction, as it greatly weakens the beam, so that comparatively light loads will produce cracks as shown at *b*. A floor joist cut as at *a*, Fig. 26, and supported as at *a*, Fig. 27, will sustain less than half of the load it would carry if reversed and supported as at *b*.

The outer ends of the second floor joists are merely sized to a uniform depth and spiked to the top of the girt if a solid girt is used. Where a false girt is used the joist should have a notch about  $\frac{3}{4}$  inch deep cut in the bottom to fit over the top of the girt, as shown in Fig. 18. Wherever practicable the joists should be placed so as to come against the sides of the studding and the two spiked together. The outer ends of the attic joists, if they rest on the plate, are merely spiked to it; if they rest on a false girt they are notched the same as shown for the second floor joists and spiked to the studding.



Fig. 27.

*Framing of Joist to Girder.*—When the inner ends of the joists are supported on a wooden girder it is cheaper and stronger to let the joists rest on top of the girder, but this often interferes with the head-room in the cellar and it permits of more settlement from shrinkage than if a flush girder were used. If the joists are framed flush into the girder, as in Fig. 28, they must be of ample size, and the girder must have sufficient width to offset the weakening effect of the mortise holes. The end of the joists should be cut as shown at *a* and *a*

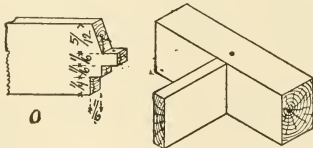

Fig. 28.

spike driven down through the top of the girder into the tenon. These proportions (which are in terms of the depth) give the greatest strength for both the beam and girder. Any cutting into a beam or girder should always be as near the centre line or neutral axis as possible, as the nearer the cut is to the edge of the beam, and particularly the lower edge, the greater is its weakening effect on the beam.

Joist hangers such as are shown in Fig. 43 would, of course, be preferable to the mortise joint, but they are not often used in frame buildings. In those of the better class, however, it would be well to

specify them, as they make much stronger construction, and the saving in labor largely offsets the cost of the hangers.

Fig. 29 shows the girder dropped 2 inches, thereby affording greater strength in the beam, but with the disadvantage of project-

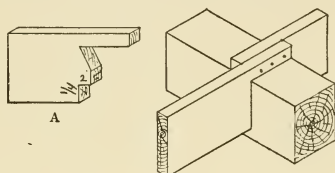

Fig. 29.

ing below the ceiling; *A* shows the proper proportions for framing the end of the beam.

**48. Framing Around Stair Wells, Chimneys, Etc.—**Should be done as shown in Fig. 30. The tail beams should be framed into the header and spiked, and the tenons on the header

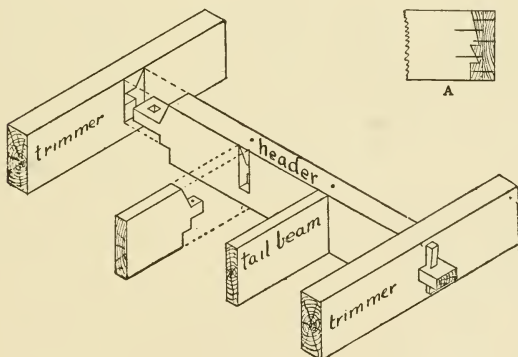

Fig. 30.

should project beyond the trimmer, so that a wedge-shaped pin may be driven in, thus bringing the pieces tightly together.

In the West the headers are generally built up of plank, the inner one being mortised to receive the tail beam, which is framed as at *A*, and the header securely spiked to it. Another plank is then spiked to the first, and often another to that. Where large timbers are not

readily obtained this answers very well for dwellings and light framing. For heavy framing all headers and tail beams should be hung in irons, as described under brick buildings. No floor joist should

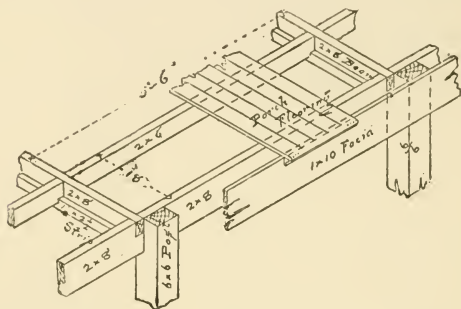

Fig. 31.

be permitted to enter the wall of any flue, but the joists should be framed around the chimney as in Fig. 35.

**49. Porch Floors** should be framed with the joists parallel with the walls of the house, so that the floor boards will be at right angles to the walls, and pitch outward an inch in 6 feet. It is also customary to drop the porch floor about 6 inches below the floor of the building.



Fig. 32.

Fig 31, from an article on isometric drawing by Charles E. Illsley, architect, in the *Inland Architect*, gives a clear representation of the proper framing of a porch floor, although brick piers would be more durable than the wooden posts shown in the figure.

If the porch is over 6 feet wide or the supports are farther apart, the size of the cross timbers should be increased accordingly.

**50. Bridging.**—After the floor joists are leveled and secured in place, and before the floor boards are laid, they should be bridged in the centre for spans between 8 and 16 feet, and twice for spans from 18 to 24 feet, by rows of cross bridging, as shown in Fig. 32. For dwelling house floors 1x3-inch bridging is sufficient; for 14-inch beams 2x3-inch stuff should be used. The pieces should be cut on a mitre and the

exact length, and each end of each piece nailed with two ten-penny nails. Both ends of the bridging should be nailed at the same time and before the joists are loaded in any way; the bridging should also be continuous and in straight lines across the room.

It should not be supposed that bridging enables a floor to carry a greater distributed load than it would support without bridging, for such is not the case, except in so far as it prevents the joists from twisting or buckling sideways. The principal benefit derived from bridging is in case of a concentrated load, such as the leg of a heavy piece of furniture, and also from suddenly applied loads, as jumping, moving of heavy articles, etc.

In such cases the beam immediately beneath the weight is materially assisted through the bridging by the beams on each side of it.

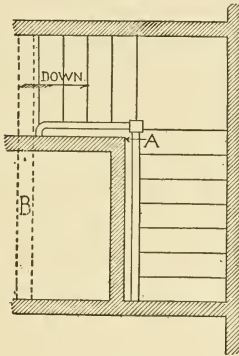

Fig. 33.

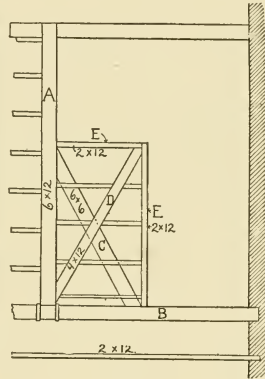

Fig. 34.

Mr. R. G. Hatfield found by testing a model floor, constructed one-eighth full size, that it required three times the load to produce *the same deflection* in a bridge beam than it did when not bridged.

**51. Framing a Projecting Corner.**—It often happens, in dwellings and tenement houses, that the stairs are built as shown by the plan, Fig. 33, and it is desirable to extend the upper floor into the stair well without any vertical support at the corner *A*. If there is a partition or girder under the dotted lines *B*, and the floor joists run at right angles to it, the projecting portion can be easily supported by merely extending the floor joists the desired distance beyond the supporting partition.

Very often, however, the joists run the other way and there is no support below, so that the corner must be made self-supporting, and just how to make it so is sometimes a puzzle to the young architect or draughtsman. Probably the best method of doing it is that shown by the partial framing plan (Fig. 34).

The trimmer *B* and header *A* are first framed in the usual way, then a heavy timber (*C*), of about half the depth of the floor joists, is framed diagonally between *A* and *B*, with its under side flush with the joists. This forms a support, at its centre, for the cantilever *L*, which in turn supports the outer end of the pieces *E*, *E*. The piece *D* should be made the full depth of the joists and notched over the piece *C*. Short pieces of joist are then cut in between the timbers *A*, *D* and *E*, and the floor is then ready for the flooring and lathing.

There are many places where this method of framing may be employed, particularly in tower stairways. The same method could be carried out with iron framing, omitting the short pieces of joists. If the projection is very great, however, and the floor is a heavy one, it will be better to support the corner directly, either by a post or rod.

**52. Laying Out.**—The framing of floors may be most conveniently drawn on tracing cloth or thin bond paper laid over the corresponding floor plan. The framing plan should show the interior supports or partitions in the story below and the framing around all openings, chimneys, etc. Provision should also be made for the support of all partitions that do not come over one below (see Sections 65 and 66) and for nailing the ends of the floor boards where they come against walls or partitions. Any necessary framing for hot air pipes and floor registers and the position of the same should be shown, and also the location of the bridging.

The size and position of all special timbers, including the beams that support partitions and all headers and trimmers, should be accurately figured, and also the size and position of all openings. In short, the framing plans should afford all information necessary for erecting the frame of the building without consulting the other plans.

If there is any special construction or peculiarity of framing required it should be indicated by three-quarter or inch scale details on the margin.

Fig. 35 shows the framing of a part of the second floor of a wooden dwelling laid out in the above manner. For large buildings the framing plans may be drawn to a scale of  $\frac{1}{8}$  inch to the foot and the common joists indicated by a single line. All special timbers should be colored yellow on the drawings to make them more prominent.





the top of a window or door opening is 2 feet or more below the bottom of the joists there is sufficient room to turn a brick arch over the opening to support the joists, but when the top of the rough opening

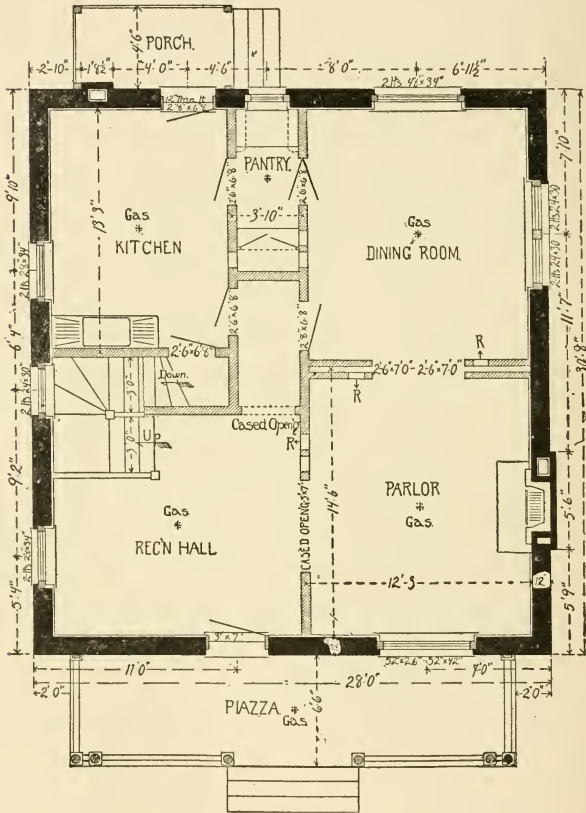

Fig. 36.

comes within 14 inches of the joists, as is usually the case with basement windows, the joists should either be framed into a header, as shown in Fig. 37, or a steel beam should be placed over the opening.



laths or furring strips; in cheap wooden buildings the under flooring is sometimes nailed to the girt and the joist omitted, but this is not good practice, as it gives no nailing for the upper flooring. In all other respects the laying out of the framing is the same as described for wooden buildings. Fig. 37 shows the framing plan of the first floor of a small brick building shown in Fig. 36, which includes all the features usually met with in brick dwellings and tenement houses.

In this case it was necessary to drop the girder 6 inches below the top of joists to give room for the boots on the hot air pipes. This is a point that should not be overlooked when laying out the framing of buildings that are to be heated by hot air.

For buildings other than dwellings heavier framing than that which has been described is often required, and, although the principles involved are the same, the details are often somewhat different. Many of these details are as applicable to wooden as to brick buildings, but as they do not as frequently occur in wooden buildings it seemed best to describe them here.

**54. Details of Floor Construction.—Wall Support and Anchors.**—The usual method of building in the outer ends of the

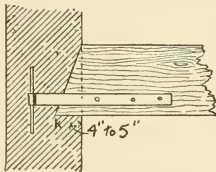

FIG. 38.

joists in ordinary brick buildings is to cut the end of the joists to a bevel and let the lower edge rest from 4 to 5 inches on the wall, as shown in Fig. 38, and every fourth or fifth joist is tied to the wall by iron anchors to prevent the wall falling outward or the joists from pulling away from it. The object in splaying the end of the joist is to permit the joist to fall, in case of a fire, without lifting the brick above or throwing the wall. In very cheap work the ends of the joists are often left square, but this should never be permitted. The anchors should be made long enough to extend within 4 inches of the outside of the wall, and should always be spiked to the *side* of the joist *near the bottom*, as shown in the figure. The nearer the anchor is placed to the top of the joist the greater will be its tendency to pull in the wall in case the joist falls.

Various forms of anchors are used for securing the joists to the wall, that shown at *a*, Fig. 39, being the most common and about as good as anv. The anchor shown at *b* answers equally as well, but

costs a very little more. Anchors like *a* and *b* are spiked to the sides of the floor joist and built into the wall, as shown in Fig. 38.

If the wall is a side or rear wall, where the appearance is not of much consequence, it is better to have the anchor pass clear through the wall, with a plate on the outside, as such an anchor gets a much better hold on the wall than is possible when it is built into the middle of the wall. The cheapest form of anchor for this purpose is that shown at *c*, which has a thin plate of iron doweled and upset on the outer end. This style of anchor may also be used for building into the middle of the wall.

For anchoring the ends of girders, or where a particularly strong anchor is desired, the form shown at *d* is undoubtedly the best. This anchor is made from a  $\frac{3}{4}$ -inch bolt, flattened out for spiking to the joist and provided with a cast iron star washer. It possesses the advantage of having a nut on the outer end, which can be tightened up if desired after the wall is built.

For anchoring walls that are parallel to the joists the anchor must be spiked to the top of the joist, and should either be long enough to reach over two joist, or a piece of  $1\frac{1}{4}$ -inch board should be let into the top of three or four joists and the anchor spiked to it.

After the floor joists are set in place and the anchors spiked to them, the brick masons fill between the ends of the joists and around the anchors with brickwork.

55. While this method of supporting and tying the ends of the joists gives ample strength for ordinary floor construction, it has two serious objections, viz., no ventilation is provided around the end of the joist and the method of anchoring is apt to destroy the wall in case of fire.

The lack of ventilation is liable to cause dry rot in the wood, especially if it is not well seasoned. Theoretically, therefore, an air space should be left around the end of the joist, but this is rather difficult to do, especially if the wall is not furred. The only practical

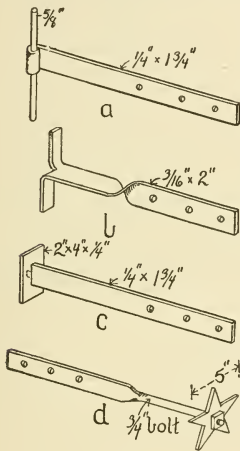

Fig. 39.

device for securing ventilation around the joist (when built into the wall) that the author is acquainted with is the Goetz Box Anchor, shown in Fig. 40. This holds the joist in position and at the same time affords an air space, as shown in plan, Fig. 41.

The second objection given above may also be avoided by using these anchors. The boxes have a lug cast on the bottom, as shown

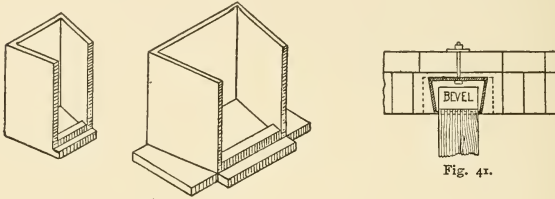

Fig. 40.

Fig. 41.

in the figure, and a corresponding notch is cut in the bottom of the joist, so that when the joist is in place it is securely fastened to the box, and, the latter being dovetailed into the wall, affords a sufficient anchor. Large beams or girders may be further secured by anchoring the box to the wall by a bolt passed through a hole in the back, as in Fig. 41. Should the joist fall, in case of fire, it releases itself from the box without pulling the wall.

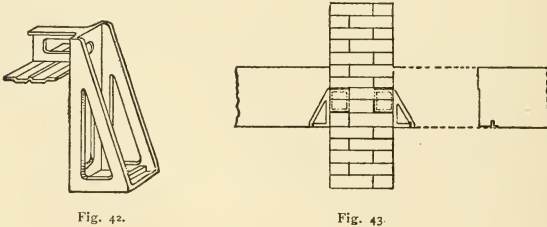

Fig. 42.

Fig. 43.

Another device for permitting the joists to fall without injury to the wall is the wall hanger, of which one type (the Duplex) is shown in Fig. 42. By the use of wall hangers the joists are hung from the wall without entering it. The bracket shown on the back of the hanger is built into the wall, and a lug on the bottom of the hanger holds the joist; every fourth or fifth hanger is also bolted to the wall. These hangers possess the advantage that they do not weaken the

wall at the floor levels, and in case the joists fall there is little danger of the wall falling also. There is also no danger of dry rot.

Wall hangers are especially desirable for party and partition walls, as where joists enter the wall on both sides they greatly weaken the wall, while when hung in hangers the wall is as strong at the floor level as elsewhere. (See Fig. 43.) As a rule, the box anchor or wall hanger is only used in large brick buildings, and particularly mercantile buildings.

The importance of anchoring the floors to the walls, and thus preventing the latter from being thrown outward, either from settlement in the foundation or from pressure exerted against the inside of the wall, cannot be overestimated and should never be overlooked.

When the first tier of joist is not more than 3 feet above the ground it is not necessary that they be tied to the wall, except in storage buildings or where the first story is over 15 feet high, but all other floors and all flat roofs should be securely anchored to all outside walls, sides as well as ends, at least once in every six feet.

In some localities the outer ends of the floor joists are supported on ledges corbeled out on the inside of the wall. For a description of this method of support the reader is referred to Part I., page 220.

**56. Wall Plate.**—Brick buildings with pitch roofs require a wooden wall plate to receive the ends of the rafters; the plate also greatly stiffens the wall to resist the thrust of the rafters. It should be made of two thicknesses of plank, 8 inches wide for an 8 or 9-inch wall and 12 inches wide for thicker walls, and should be bolted to the top of the wall by  $\frac{3}{4}$ -inch or  $\frac{5}{8}$ -inch bolts at least 2 feet long, imbedded in the brickwork. On the lower end of the bolt a large washer of wrought iron should be placed to hold the bolt in the wall. The planks should break joint, and where possible the plate should form an unbroken tie around the building. Before bolting the plates in position they should be bedded in mortar. For small dwellings a single plank is sufficient, but it should extend from angle to angle. The rafters are spiked to the plate, as in wooden buildings, and often the attic joists rest on the plate and are spiked to it. (See Figs. 78 and 83.) When the plate is above the attic floor diagonal ties or braces should be spiked to the rafters and to the floor joists, as in Fig. 78, to prevent the roof from spreading the walls.

The rafters of flat roofs are built into the wall in the same way as the floor joists, and the wall carried 12 or 18 inches above the roof.

**57. Framing of Headers and Trimmers.**—The ordinary method of framing around openings, by mortise and tenon joint, was

shown in Fig. 30. This method answers very well where the floors are not apt to be heavily loaded or the openings very large. In first-class dwellings, however, and all larger buildings, the author recommends that all headers over 4 feet long be supported at the ends by iron hangers or stirrups instead of by mortising. In heavy construction the saving in the extra amount of lumber required by the old method will offset the cost of the hanger. The full strength of the header, at the end, is obtained, and in case of fire such a joint would stand much longer than the mortise and tenon joint.

Most building laws also require that headers over 4 feet long, in all buildings except dwellings, shall be hung in hangers or stirrups.

For dwellings and light construction the author recommends the use of the Goetz and Duplex Hangers, shown in Fig. 44, or of the Lane Hanger, shown on page 461.

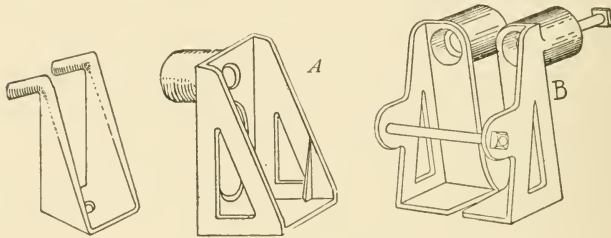

Fig. 44.

These hangers are made in a great variety of sizes to suit any size of timber, and are now carried in stock in most of the larger cities. They are supported by inserting the lugs into holes bored near the centre of the trimmer, and thus possess the advantage over stirrup hangers that they are affected by only about one-half the shrinkage in the trimmer, while the ordinary stirrup iron is supported at the *top* of the timber, and consequently the bottom of the stirrup must settle, and the header with it, by the amount of the shrinkage in the trimmer. Unless the trimmer is well seasoned this dropping of the header, due to the shrinkage of the trimmer, will be sufficient to crack and distort plastered ceilings. Even where the joist hangers are used pins should be taken to secure well-seasoned timber.

With the Goetz Hangers the beam supported is tied to the hanger by a spike, driven through a hole in the bottom of the hanger into the beam; for large timbers lag screws may be used. The Duplex Hanger of the smaller sizes holds the joist by means of lugs on the



sides, as shown in the cut at *A*; the larger hangers have a bolt which passes sideways through the end of the joist, as at *B*. The Duplex Hanger may also be bolted to the trimmer, as shown in Fig. 45, thus absolutely preventing any possibility of the trimmers spreading. If the headers are very long the tail beams also should be hung in hangers, as shown in Fig. 46. Where the headers are short the tail beams are generally mortised into the header in the usual way.

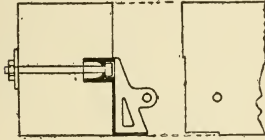

Fig. 45.

58. *Stirrup Irons*.—Until within a very few years stirrup irons, such as are shown in Figs. 47, 48 and 49, were used exclusively for supporting the ends of beams where a mortise and tenon joint was not desirable. The only objection to stirrup irons is the dropping of the header

due to shrinkage and the fact that they are not generally carried in stock. They can easily be made, however, by any blacksmith, and a few shops make them to sell to the trade. When made to order they should cost about  $4\frac{1}{2}$  cents per pound. In warehouses, where the ceilings are not plastered, the stirrup iron is possibly still to be preferred to the hangers above described, as with the stirrup there can be no weakening of the trimmer.

Stirrup hangers should be made from  $\frac{3}{8}$  to  $\frac{5}{8}$ -inch thick and from 2 inches to 4 inches wide, according to the size and length of the timber they support. They may be made double, as shown in Fig. 47, or single, as shown in Fig. 49. When single the end of the hanger should turn down at least  $1\frac{1}{2}$  inches over the other side of the trimmer. As stirrup irons are ordinarily used, the end of the header

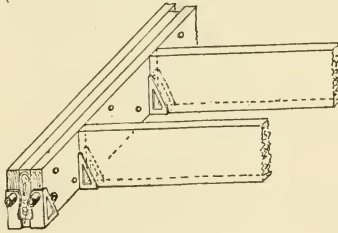

Fig. 46.

is simply spiked to the trimmer to keep the latter from spreading until the floor is laid, the latter being depended upon finally to keep the trimmers from spreading, and thus permitting the header to drop.

A much better method, and one quite common in Boston, is to tie the end of the header to the trimmer by a  $\frac{3}{4}$  or  $\frac{1}{2}$ -inch "joint bolt," which is an ordinary square-headed bolt about 18 inches long. A

hole slightly larger than the bolt is bored through the trimmer and into the end of the header. A square hole is then cut into the side of the header, as at *A*, Fig. 48, just large enough to slip in the nut, which is pushed in opposite the bolt hole and the bolt then pushed in, the screw end started in the nut and the bolt then screwed up by turning the head. This brings the two timbers tightly together and gives a perfectly dead weight on the hanger.

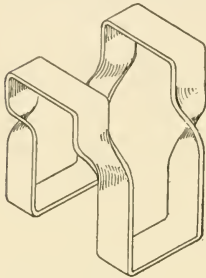

Fig. 47.

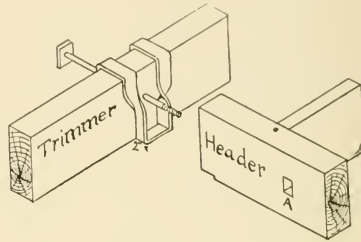

Fig. 48.

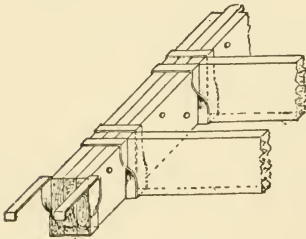

Fig. 49.

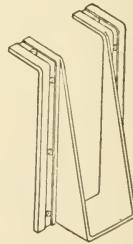

Fig. 50.—Van Dorn Hanger.

The following table shows the size of iron bar recommended for stirrups, and also the safe strength of the stirrup:

SIZE OF IRON.	SIZE OF JOIST SUPPORTED.	SAFE STRENGTH OF STIRRUP.
$\frac{1}{2}$ x 2 inches.	2x 8 to 3x10	10,000 pounds.
$\frac{3}{4}$ x 2 " "	4x10 to 4x12	18,000 " "
$\frac{1}{2}$ x 3 " "	6x12 to 3x14	22,000 " "
$\frac{3}{4}$ x 3 " "	8x12 to 4x14	30,000 " "
$\frac{1}{2}$ x 4 " "	6x14	36,000 " "
$\frac{3}{4}$ x 4 " "	8x14	40,000 " "
$\frac{1}{2}$ x 4 " "	10x14	45,000 " "

Fig. 50 shows a new style of hanger recently placed on the market. It is forged from rolled steel and should make a very strong hanger, but would be improved by hooking the top plates over the back of the beam. The hanger is designed to be fastened to the trimmer by spikes.

**59. Fitch Plate Girders.**—It sometimes occurs in dwellings that it is necessary to use very long trimmers or headers around stair wells, and in most cases it is desirable that they shall be of the same depth as the floor joists. In such cases it is difficult to get sufficient stiffness without using iron or steel. Where steel beams are too expensive to use, a compromise may be made by using a fitch plate

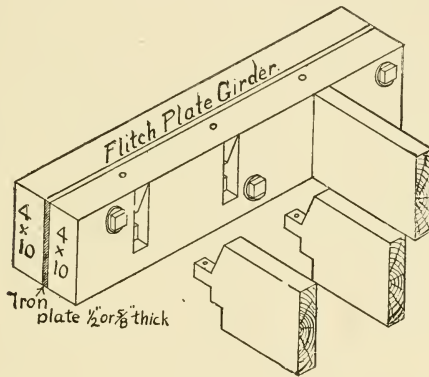

Fig. 51.

girder, which is a beam built up of two pieces of timber bolted to each side of a steel beam or plate, as shown in Fig. 51.

For such beams as may be required in dwellings a piece of boiler iron plate, of the same length and depth as the timber, and from  $\frac{3}{8}$  to  $\frac{1}{2}$  inch thick, will generally answer.

The total thickness of the timber should be about twelve times that of the plate.

The pieces should be bolted together by  $\frac{3}{4}$ -inch bolts, spaced 18 inches to 2 feet apart, and 2 inches from the edge. It will generally be better to keep the iron  $\frac{1}{2}$  inch narrower than the timbers, to allow for shrinkage in the latter.

The *safe distributed load* may be calculated by the formula

$W = \frac{2D^2}{L} (fb + 750t)$ ;  $D$  being the depth of the iron in inches,  $b$  the total breadth of the timber,  $t$  the thickness of the iron,  $L$  the clear span in feet and  $f$  the coefficient of strength for the timber (100 for Georgia pine, 70 for spruce, 60 for white pine). Such a beam will be much stiffer than a wooden beam of the same strength, and considerably cheaper than a steel beam, especially when the furring of the beam for plastering is taken into account.

Fitch plate beams may also be used for supporting brick walls, but for this purpose they are not as desirable as steel beams.

*Example.*—What is the safe distributed load for a fitch plate girder, built up of two 3x12 spruce beams and a  $\frac{1}{2}$ x11 $\frac{1}{2}$ -inch plate, the clear span being 16 feet?

*Answer.*— $W = 2 \times \frac{(11\frac{1}{2})^2}{16} (70 \times 6 + 750 \times \frac{1}{2}) = 13,142$  pounds.

**60. Girders.**—In brick dwellings girders are generally used only for supporting the first floor, and in the same way as described in Section 47. In heavier buildings the load on the girders becomes so great that it is necessary to utilize the full section of the girder, and very often steel beams are required.

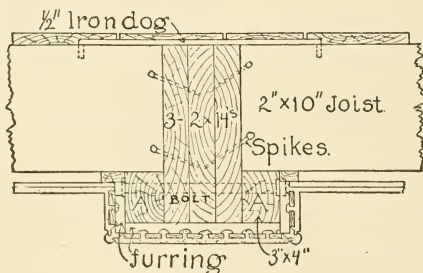

Fig. 52.

In mercantile buildings and warehouses it is customary to drop the girders below the beams, so as to avoid framing the beams into them.

*Heavy Wooden Girders.*—When heavy wooden girders must be kept flush with the joists the latter should be supported by joist hangers or stirrups.

Generally, however, it is necessary to make the girder deeper than the floor joists, in which case the latter may be supported by bolting long pieces of 3-inch hard pine plank to the bottom of the girder, as shown in Fig. 52.

The depth of these pieces should be at least 4 inches for 10-inch joists, 5 inches for 12-inch joists and 6 inches for 14-inch joists. Three-quarter-inch bolts, spaced from 16 to 20 inches, may be used for 10-inch joists, and  $\frac{3}{8}$ -inch bolts, spaced 20 and 16 inches respectively, for 12 and 14-inch joists. The bolts should be placed a little above the centre of the bearing strips, and the ends of the joists should be spiked to the sides of the girder, as shown in the figure.

The joists may also be supported on  $3\frac{1}{2} \times 4$  inch angle bars, bolted to the girder, as shown in Fig. 53. This method is undoubtedly better than that shown in Fig. 52, as there will not be as much settlement from shrinkage, and there is also less bending moment in the bolts.

In a great many small cities and towns, however, such angles are not carried in stock, and the expense of getting them will prohibit their use. Ordinary bolts can be readily obtained in almost any locality and at a comparatively small price.

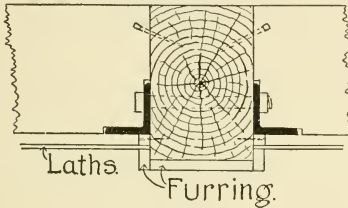

Fig. 53.

The use of angle bars also necessitates furring or strapping the ceilings, as laths cannot be nailed to the metal.

Figs. 52 and 53 also show the manner of strapping the girders for lathing.

In designing the girders it should be remembered that deep girders are more economical than shallow ones, and when framed flush, or nearly so, on top, they prevent passage of fire through the floors.

*Built-up Wooden Girders.*—In many localities it is impossible to obtain large timbers without making a special order for them from the mills, while planks of almost any size can be readily obtained, and generally at a less price per thousand feet. In such cases the girders may be built up of several planks placed side by side, as in Fig. 52, and bolted together. The planks, however, should always break joints over a support. The bolts need not be larger than  $\frac{3}{8}$  inch in diameter, and spaced 2 feet on centres, in staggered rows, two bolts being placed at each end of the girder. Where each plank is the full length of the girder, the only use of the bolts is to keep the planks together and to distribute the load on all the planks.

The author believes that girders built up in this way are better

than solid girders, and of equal if not greater strength. They certainly are not as likely to warp, and there is less chance of using decayed timber.

**61. Steel Beam Girders.**—When it is desired to keep steel girders flush with the floor joists the latter may be supported by bolting a plank to the side of the beam and inserting joist hangers into holes bored in the plank, as shown in Fig. 54. For ordinary construction this is probably the cheapest and simplest method of framing, as the planks also afford nailing for the furring strips.

Another method of supporting the ends of the floor joists is to rivet angle irons to the sides of the beam, as shown in Fig. 64. With this method there can be no settlement of the joists from shrinkage, but either method may be recommended. On account of the almost

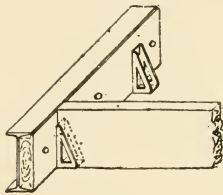

Fig. 54.

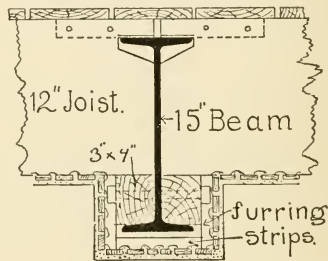

Fig. 55.

inevitable shrinkage of the joists, it is better that the depth of the steel beam be 1 inch less than that of the wooden beams, so that the top of the steel beams may be dropped 1 inch.

When the steel beam is deeper than the floor joists the latter may be supported by bolting 3x4 hard pine strips to the beam, as shown in Fig. 55. As the strips have a bearing on the lower flange of the beam, they need not be more than 4 inches deep, even for 14-inch joists. Angle irons may also be used for supporting the joists, but the wood strips are generally preferred where the ceiling is to be plastered, as they are much more easily furred for lathing or casing.

Whichever of these methods of supporting the joists is used, enough bolts or rivets should be used to sustain the load carried by the strips or angles. [Each  $\frac{3}{4}$ -inch bolt may be allowed to support 3,000 pounds on each side of the girder, and each  $\frac{7}{8}$  inch bolt 4,000 pounds.]

**62. Stiffening a Weak Floor.**—A floor that sags or springs considerably under moving loads may be made much stiffer by taking up a couple of floor boards every 6 feet in the length of the floor and fitting slightly wedge-shaped blocks between the beams, in a continuous line, as shown in Fig. 56. The blocks should be made of 3-inch plank, of the full depth of the floor joist, and cut so that the grain of the wood will be at right angles to the joist, that they may not become loose as the wood shrinks.

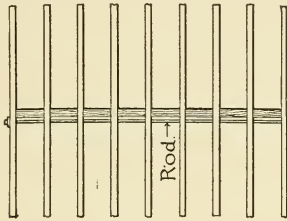

Fig. 56.

Before putting the blocks in place holes should be bored through the centres of the beams and a  $1\frac{1}{4}$ -inch rod passed through all the beams, the rod having a head at one end and a nut on the other. After the rod is in the blocks should be fitted closely in place and the nut then screwed up until the floor becomes crowned, owing to the shape of the blocks. A floor crowned in this way acts like a truss, and will be much stiffer under a moving load than when simply bridged in the ordinary way, although the strength of the floor, to support a distributed load, such as grain or large boxes of merchandise, is in no way increased. If the floor and ceiling must be kept perfectly level the top of the beams will, of course, either have to be dressed off or the floor furred to a level, and the ceiling will also have to be furred.

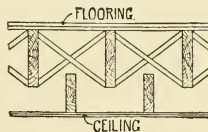

Fig. 57.

**63. Floors with Independent Ceiling Joist.**—Floors have frequently been constructed with independent timbers for the floor and ceiling, the ceiling joists being placed between the floor joists, as shown by the cross section, Fig. 57.

The object of using two sets of joists is to prevent the passage of sound, and sometimes, as in dance halls, to prevent the vibration of the floor being communicated to the ceiling. While this construc-

tion is undoubtedly the most perfect (when wood must be used) for accomplishing these objects, it is very objectionable from the standpoint of fire protection, as it affords free passage for flames in both directions, and the material is so disposed as to be rapidly consumed. It should, therefore, never be used in public buildings unless protected underneath by metal lath and plaster, and above by some fire-proof material, such as "Salamander," laid between the floor boards. It is probably hardly necessary to say that this is not an economical construction, as it requires much more lumber to obtain the same degree of stiffness for both floor and ceiling, when divided into two beams, than it does when all the wood is in one beam.

It has also been quite a common custom in the construction of school house floors, in some sections of the country, to lay 2x4-inch scantlings on top of the floor beams, and at right angles to them, for the purpose of ventilating the rooms through the floors into the vent shafts.

Such construction should never, under any circumstances, be adopted, as it forms a veritable fire trap in case a fire should be started in the room above.

#### PARTITIONS.

64. The partitions in buildings of ordinary construction are usually built of 2x4-inch studding, spaced either 12 or 16 inches on centres, giving five or four railings to the lath respectively. For bearing partitions, and also where the stories exceed 9 feet 6 inches in height, the spacing should not exceed 12 inches, as 16-inch spacing does not give sufficient stiffness for first-class buildings. For partitions exceeding 11 feet in height 5 or 6-inch studding should be used. A partition built of 2x5-inch studding, spaced 16 inches on centres, is much stiffer than one built of 2x4-inch studding 12 inches on centres, although the latter contains the more lumber. A spacing of 16 inches, however, does not make as stiff a job of plastering, and for this reason a spacing of 12 inches is to be preferred in the better class of houses, no matter what the size of the studding may be. Five or 6-inch studding also gives much better accommodation for furnace pipes and soil pipes than the 4-inch studding.

65. **Supports for Partitions.**—In putting up the partitions it is important to build them so that there shall be as little settlement from shrinkage as possible. The *ordinary* method of building partitions, particularly in buildings not superintended by an architect, is that shown in Fig. 58, which shows the studding of a first story par-



tion and the bottom of the second story partition. From an inspection of this figure it will be seen that there are 37 inches of horizontal wood between the top of the basement piers and the bottom of the second story studding, and, as ordinary spruce or white pine timber will shrink across the grain about  $\frac{1}{2}$  inch per foot, it would probably be found at the end of one or two years that the second story partition had settled  $1\frac{1}{2}$  inches, and of course the third story or attic joists would settle with it. The shrinkage of timber endways is imperceptible. If the first and second floor joists were supported at the outer ends as shown in Fig. 20 there would be but 14 inches of horizontal timber between the foundation wall and the second floor joist,

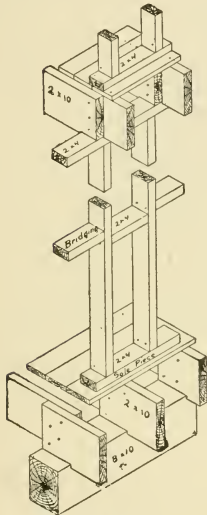

Fig. 58.

which allows of a shrinkage of only about  $\frac{1}{2}$  inch, so that the inner ends of the second floor joists in a wooden building will be about  $\frac{3}{4}$  inch lower than the outer ends when the timber has had time to shrink. In a brick building the difference in height between the outer and inner ends of the second floor joists will be still greater, as the settlement of brickwork in the height of one story is hardly noticeable. It is from this cause more than from any other that cracks in the plastering of dwellings are so common, and that the doors in partitions running parallel with the joists will not shut after a year or two. It is not always possible to overcome all settlement from shrinkage, but any considerable settlement can generally be avoided, and

this is one of the points in which architects' houses should excel those of the speculative builder. If the girder supporting the first floor had been framed flush with the joists and the second story studding had been supported on the cap of the first story partition, as shown in Figs. 59 and 60, there would have been only about 15 inches of horizontal wood below the second floor, so that both ends of the joists would settle about the same. Hence in all cases where a partition in the second story comes over one below, *the second story studding should rest on the cap of the lower partition, and the lower studding should rest directly on the girder, if there*

is one. If the partitions run the same way as the floor joists they should be constructed as shown in Fig. 60, the floor joists next the partition being kept away 2 inches to afford nailings for the upper floor boards.

When the partition does not come over a girder or over a partition it is obvious that it must be supported in some way by the floor timbers. When the partition runs *parallel with the joists* it is often supported by placing a double joist in the floor directly under the parti-

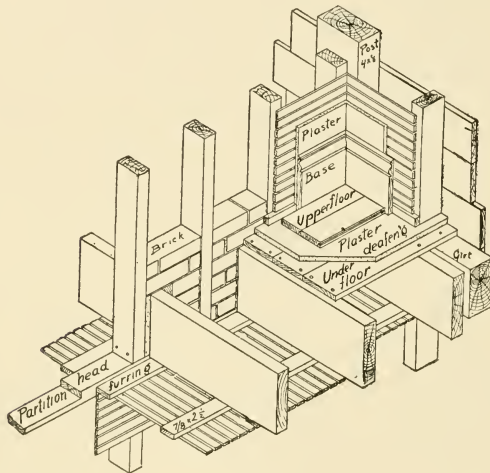

Fig. 59.

tion. This method is objectionable, however, for two reasons: (a) If the beam is not at least 3 inches wider than the partition it does not give a nailing for the ends of the upper floor boards; and (b) if there are any pipes to run up in the partition, as is often the case in first story partitions, the beam must be badly cut into to let them by. For these reasons it is better to use two joists spaced about 6 inches apart and bridged every 16 or 18 inches with plank bridging, as shown in Fig. 61, the grain of the bridging *always* being horizontal. This gives a good nailing for the floor boards and permits of hot air pipes being carried up in the partition without cutting any timber.

The two joists which support the partition should each be at least 3 inches thick, and in some cases it may be necessary to make them 4 inches thick, as any bending of the joists will cause the partition to settle by a corresponding amount; and if the partition bearing

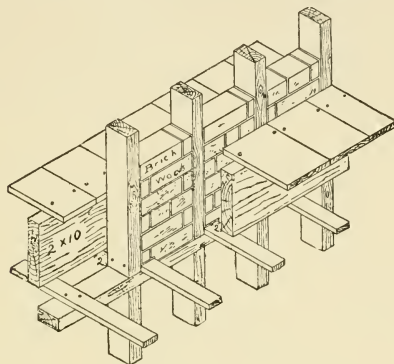

Fig. 60.

joists bend more than the other floor joists it will produce a bad appearance in the ceiling.

Wherever a partition rests on top of the beams or flooring it will, of course, settle by an amount equal to the shrinkage of the joists, and in brick buildings this is often sufficient to cause a crack to appear at the angle formed by the partition and outside wall.

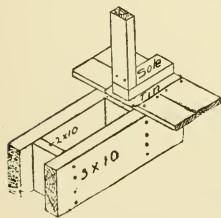

Fig. 61.

In first-class brick dwellings, therefore, the only sure provision against cracks is to support all partitions either on steel beams or in the manner shown in Fig. 62, when they cannot be supported on partition caps. Steel beams undoubtedly make the best support, but where they cannot be used, either on account of the cost or the ne-

cessity of placing pipes in the partition, the effect of shrinkage may be overcome by screwing iron plates 4 inches wide and  $\frac{3}{8}$  or  $\frac{1}{2}$  inch thick to the bottom of the joists by 4-inch lag screws (as shown in Fig. 62) for the studding to rest on.

If the joists are then made of ample strength there can be no

settlement in the partitions, and consequently no cracks in the plaster from that cause. When the partitions are supported in this way the ceilings should be furred with 1-inch strips for lathing.

When steel beams are used they should be at least 1 inch less in depth than the wooden beam to allow for shrinkage in the latter.

When the partition runs *crossways* of the joists it is generally supported simply by a sole piece laid across the joists or on top of the under floor, as in Fig. 58, and in such case the joists must be stiff enough to support the *concentrated* weight from the partition. It

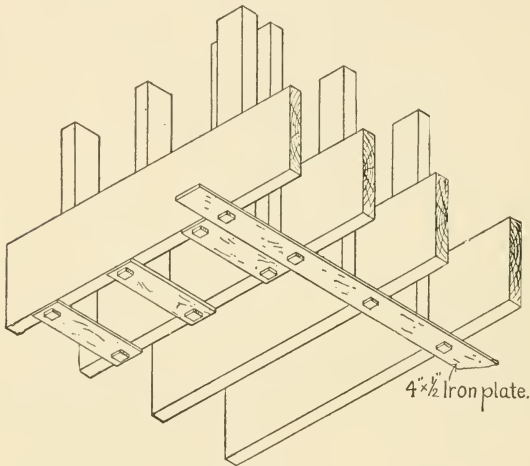

Fig. 62.

should be remembered that the weight of a partition running crossways of the joists and near the middle of the span has *twice* the destructive effect that a distributed load would have, and no relief can in this case be gained by bridging. If there should be wide openings in such a partition, the floor joists under the studding at the side of the openings should be increased in proportion to the weight coming upon them. This is an important point in construction and one often overlooked.

66. The effect of the shrinkage of the joists on a partition supported in this way is, of course, the same as in the case above mentioned, and it can be avoided in the same way. If a steel beam

is used to support the partition, however, it will be necessary to frame the joists into it, either as shown in Fig. 63 or Fig. 54.

In first-class brick dwellings all first story partitions should be supported either by steel beams or brick walls. If the first story partition supports another in the second story, the beam must, of course, have sufficient strength and stiffness to support all the partitions above it without undue deflection.

It is also desirable, in brick buildings at least, to support the partitions and floor joists around stairways with steel beams, as shown in Fig. 64.

When the partition is continuous with one below, as is most generally the case, the studs should be halved over the beam, to the

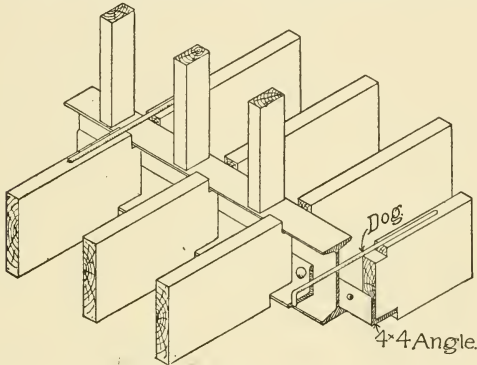

Fig. 63.

partition head below, so as to give a nailing for the laths and to prevent cracks in the plastering.

It sometimes seems necessary to support part of a second story partition on a partition cap and part on the floor joist, but this can generally be avoided by using the plates shown in Fig. 62.

**67. Trussed Partitions.**—Where a partition runs parallel with the joists, and comes over a room below of considerable width, it may be prevented from sagging by trussing, as shown in Fig. 65. The extra cost of trussing is very small, and by it sagging can be entirely prevented; and if the rods and braces are properly proportioned, the partition may be used to support floors or other partitions above. When built the partition should be slightly crowned, as the truss is sure to settle a little when the timbers have

seasoned When trussing is employed care should be taken to see that the supports under the ends of the truss are ample.

Trussing, however, will not prevent settlement from shrinkage unless the bottom member of the truss is thoroughly seasoned.

**68. Partition Heads.**—The top of all wooden partitions generally consists of a piece of studding called the cap, which is spiked to the upper end of the studding before the partition is raised. When the partition runs at right angles to the floor beams above the cap is fitted against the underside of the joists. When the par-

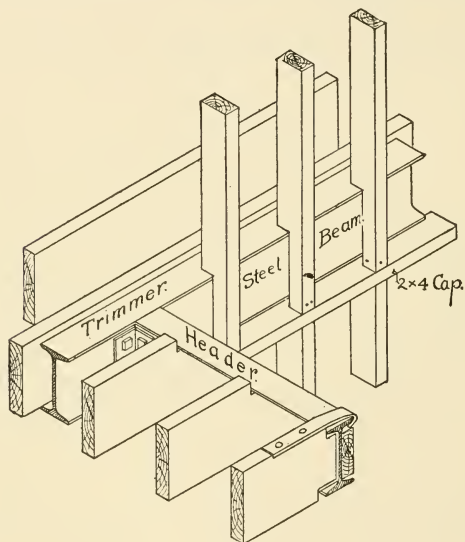

Fig. 64.

tion is parallel with the floor beams above, and the latter are "strapped" underneath, the cap is nailed to the underside of the strapping, or furring, as shown in Fig. 60.

If the ceiling is not strapped, then the cap should be secured about every 3 feet by means of cross pieces, C, Fig. 66, spiked between the joists and to the top of the cap. Pieces of boards about 3 inches wider than the cap are then spiked on top of the latter to receive the ends of the laths.

In cheap work the cap *A*, Fig. 66, is sometimes omitted, and the board *B* is nailed directly to the studding, the latter being cut so that the underside of the board will be level with the bottom of the joists. The cross pieces, *C*, are then nailed above the board.

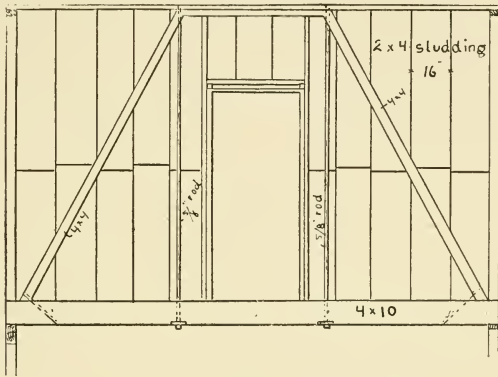

Fig. 65.

Where the span of the floor beams is more than 12 feet, the cap of all bearing partitions should be 3 inches thick, and if the span is over 16 feet and the studding 16 inches on centers, the cap should be 4 inches thick. In first-class work it is customary to specify Georgia pine or Oregon pine for the partition caps, as these woods are much stiffer than spruce or white pine, and not so apt to warp.

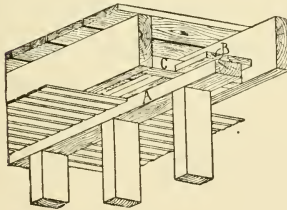

Fig. 66.

During the construction of the building precaution should be taken to see that the end of a heavy timber, or the studs at the sides of a wide opening, are properly supported when they come over a space between the studs below.

**69. Corners.**—The corners of all intersecting partitions should in all cases be made solid, either as at *a*, Fig. 67, or as at *b*. The arrangement shown at *a* is the best, but *b* answers very well if the stud *c* is nailed to the horizontal bridging between the other two. In

no case should the laths be permitted to run by the end of a partition. Where the partition joins an outside wooden wall the corner should be made solid in the same way. When the partition comes near the middle of the wall, a 4x6 or 4x8 post should be set in the wall opposite the partition, as shown in Fig. 59.

Where wooden partitions join a brick wall it is a good plan to bolt

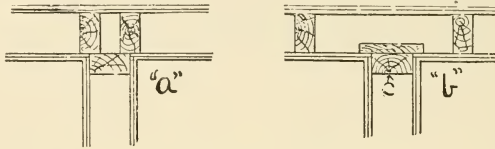

Fig. 67.

the last stud to the wall once or twice in the height of the story by  $\frac{3}{4}$ -inch bolts embedded in the wall as it is built. Doing this strengthens the wall and tends to prevent cracks in the angle formed by the partition and wall.

**Trussing Over Openings.**—At the sides of all openings in partitions the studding should be doubled, and the partition over the opening trussed as shown either in Fig. 68 or Fig. 69.

When the opening does not exceed 3 feet, and there is no weight resting on the partition cap, the trussing may be omitted. The “head” of the opening should always be formed of two pieces, kept 1 inch apart as shown in the figure, so that if the upper one sags it will not affect the lower one to which the door finish is nailed.

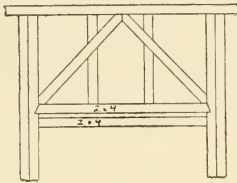

Fig. 68.

**Bridging.**—All partitions should be bridged at least once in their height with 2-inch bridging the full width of the studding. The pieces should be placed horizontally, as shown in Fig. 58. Bridging stiffens the partition considerably and also prevents the passage of fire or vermin. When a partition is ceiled or wainscoted *flush* with the plaster it is necessary to cut in bridging between the studding to receive the nails.

**70. Sliding Door Partitions.**—These are made double, the studding being kept about 4 inches apart. When 2x3 studding can be obtained it is frequently used for these partitions, otherwise 2x4 studding must be used, either placed flatways or edgeways. The former method is



hardly stiff enough for stories exceeding  $9\frac{1}{2}$  feet in height, and should never be used for first-class work. If the partition is a bearing partition, one side may be made thicker than the other to carry the floor above. It is customary in the better class of buildings to sheath the inside of the partition with thin matched boarding to prevent the plaster from getting on the tracks or in any way interfering with the

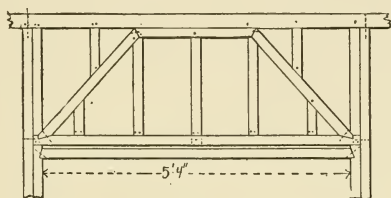

Fig. 69.

working of the doors; this sheathing should be put on when the partition is set up.

*Staggered Partitions.*—It is desirable that partitions separating two tenements, stores or apartments, shall transmit sound as little as possible. The transmission of sound can be prevented considerably by filling the partition between the laths with mineral wool or with soft bricks laid up in mortar. The best way in which to accomplish this object, however, is to build the partition with two sets of studding, staggered as shown in Fig. 70, and kept entirely separate and independent of each other. If the two sides of the partition do not connect in any way, or touch each other, there will be very little sound transmitted through the partition. By tacking Cabot's deafening



Fig. 70.

“Quilt” to one set of studding the deadening will be nearly, if not absolutely, perfect, and the quilt will also, it is claimed, retard the progress of fire. Heavy felt paper may be used instead of the “Quilt,” but the author believes that the “Quilt” is the better material for the purpose.\*

\*For a description of this “Quilt” see Chapter V.

*Hot Air Pipes and Plumbing Pipes.*—The position of all hot air and plumbing pipes should be carefully considered in making the plans, and provision for them made in framing the partition and floors. When a 4-inch soil pipe is carried in a partition the studding must be either 5 or 6 inches wide, or else the partition must be furred out around the pipes.

**71. Fire Stops.**—The architect who is mindful of the interests of his client should always take such precautions as he can to make his building not only strong and durable, but also as slow burning and inaccessible to vermin as may be practicable. This can be done to a considerable extent without much additional cost. One of the best preventatives to the progress of fire is to stop all spaces between the floor joists and in the partitions with soft brick or fireproof tiles laid in mortar, as shown in Figs. 59 and 60. The spaces between the ends of the first story joists and over all dropped girders should be filled with brickwork in the same way. This will prevent the rapid passage of fire between the joists from one side of the building to the other and up in the partitions. If the partitions are bridged, and one or two courses of brickwork laid on top of the bridging, an additional stop to fire rising in them is provided. If a fire can be prevented from ascending in the partitions and spreading between the joists for fifteen or twenty minutes after it is discovered it can generally be controlled without destroying the building. Partitions which rest on the floor, with no partition below, should have a piece of tin 3 or 4 inches wider than the partition placed under the sole piece, as shown in Fig. 61. If the building is balloon frame, 2x4 bridging should be cut in between the studding of the outside walls, just below the ledger board or false girt, and brickwork laid on top to at least 5 inches above the top of the joists. This will not only prevent fire from ascending in the walls, but will prevent the ledger board from being quickly burnt through. The space between the timbers around smoke flues and all similar places, where fire or mice could pass through, should be filled solid with mortar or mineral wool. In general fire will not make much headway where there is no draught, and every pains should be taken to prevent the passage of flames through the concealed portions of the building. Mineral wool is a very efficient article for stopping the progress of flames and vermin, also of sound and heat.

## ROOF CONSTRUCTION.

**72. Pitch Roof.**—The proper construction of a roof depends in a great measure upon the shape of the roof, the size and arrangement of the building and the use that is to be made of the enclosed space or “attic.”

The shape of the roof will be governed principally by the size and plan of the building, the external effect sought and whether or not the roof space is to be finished.

Before describing the methods of construction, it seems desirable to consider briefly the various shapes of roofs and to define the principal parts.

All roofs which have an inclination of  $20^{\circ}$  or more with a horizontal plane are called “pitch” roofs, and those whose inclination is less than this are called “flat” roofs.

The “pitch” of a roof is the angle of inclination which the rafters make with a horizontal plane; it is sometimes expressed in degrees, but more often by the proportion which the height in the centre bears to the span, or by the rise in inches for each foot of half span. The last method is the simplest and least likely to be misunderstood, and is preferred by the author.

Below is given the rise and angle for the most common pitches :

Two-thirds pitch.....	rise, 16 ins. in 1 ft.;	angle, $53^{\circ} 52'$
Half pitch (square pitch).....	“ 12 ins. in 1 ft.;	“ $45^{\circ}$
One-third pitch.....	“ 8 ins. in 1 ft.;	“ $33^{\circ} 41'$
One-fourth pitch.....	“ 6 ins. in 1 ft.;	“ $26^{\circ} 34'$
.....	“ 7 ins. in 1 ft.;	“ $30^{\circ} 15'$

In deciding on the pitch of the roof for any given building the following conditions should be considered : Appearance (in connection with the style of architecture), climate, nature of the covering and cost. In dwellings, churches, etc., external appearances generally determines the pitch, while for factories, sheds, etc., the last two conditions are usually the controlling ones.

High pitched roofs are considered best adapted to climates which have considerable rain and snow, as in our Northern States, while a low pitch with heavy projections seems most suited to warm climates.

The most economical pitch for small buildings is that which has a rise of about 9 or 10 inches to the foot ; and for trussed roofs, about  $30^{\circ}$ . Shingle roofs should have a pitch of at least 6 inches to the foot, except on sheds and porches, where it may, if necessary, be reduced to  $4\frac{1}{2}$  inches. Roofs covered with slates of large size may be made as flat as 5 inches to the foot, but a steeper pitch is to be pre-

ferred. Clay or metal tiles should in general have a pitch of at least 7 inches to the foot, and for a desirable effect a square pitch is necessary. The relation of the pitch to the roof covering will be more fully considered in Part III.

**73. Types of Roofs.**—The simplest roof is the “lean-to,” or shed roof, shown in Fig. 71, which has but one slope. This roof is used principally on sheds, one story projections and porches.

The roof shown in Fig. 72 is called a “gable,” or “V” roof. This is the easiest roof to build, next to the shed roof, and for small dwellings the most practical roof.

The type of roof shown in Fig. 73 is called a “gambrel,” or “curb” roof; it is very commonly seen on the buildings of the

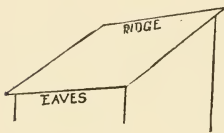

Fig. 71.

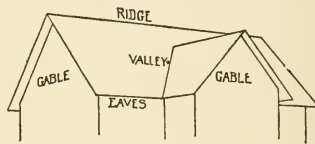

Fig. 72.

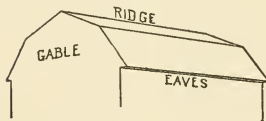

Fig. 73.

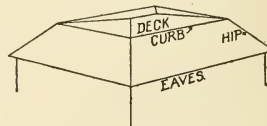

Fig. 74.

Colonial period, and was evidently adopted because of its giving ample attic space, without the great height of the V roof. It is best adapted to comparatively wide buildings with finished attics. For the same span it requires less lumber and covering material than the V roof, while it gives about the same amount of available space inside.

The “mansard,” or “French” roof, is like the gambrel roof, except that the first pitch is steeper than in the gambrel roof. The mansard roof also generally slopes from all four sides of the building.

When the roof slopes back from the ends of the building, the same as at the sides (see Fig. 75), it is called a “hipped” roof, and when it terminates in a flat roof, as in Fig. 74, it is called a “deck” roof.

Considering the saving in the gable walls, a hip roof is cheaper than a gable roof, and when the width of the building is over 30 feet a deck roof is still cheaper. Hip and deck roofs are most com-

monly used on large buildings. Mansard roofs are often used on large dwellings, and also on hotels and office buildings.

**74. Ordinary Roof Construction.**—The common method of framing wooden roofs is illustrated by Fig. 75. The timbers which support the boarding are called rafters; they are supported at or near their lower end by the wall plate, and at their upper end by the ridge pole or by another rafter. At all ridges or valleys larger timbers are placed to receive the ends of the roof boarding, and also of the short pieces of rafters. The timbers under the hips and valleys are called hip and valley rafters, respectively, and the rafters which cut against them are called "jack rafters." When the length of the rafters is over 18 feet it is desirable to support them somewhere near their

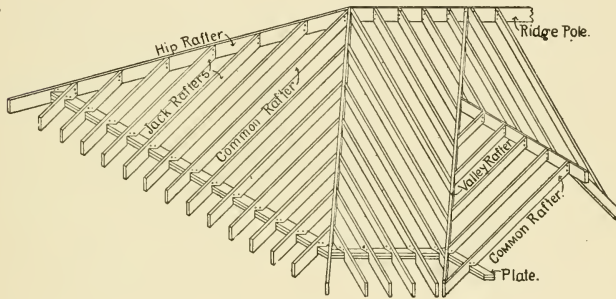

Fig. 75.

centre. In dwellings this is generally done by means of studding or partitions, and sometimes by "collar" beams; in larger buildings the centre support is furnished by means of purlins resting either on trusses or on posts set over the interior walls or columns.

**75. Laying Out the Roof Plan.**—To lay out a pitch roof for an irregularly-shaped building so that it will look well and properly sustain itself and the pressures liable to come upon it requires some little experience. The method which the author has always followed in designing a pitch roof where the building is of irregular plan is to draw an outline plan of the walls of the building, and on this construct the greatest rectangle that will be contained within it. This rectangle can then be covered with a hip roof and the various projections subordinated to it.

Thus in Fig. 76 we have the outline of a building which is to be

covered with a pitch roof: The greatest rectangle that can be drawn within these lines is indicated by the letters *a, b, c, d*. From the corners of this rectangle draw lines at  $45^\circ$  until they intersect, and join the two intersecting points. The  $45^\circ$  lines represent the hips of a roof, and the connecting line will be the plan of the ridge, and the length and position of these lines in the roof plan will be the same for any degree of inclination of the roof, provided all portions of the roof have the same pitch. Having obtained the lines of the main body of the roof we proceed to draw the roof lines of the various projections, first drawing them all for hip roofs and afterward erasing the hip lines and extending the ridge if a gable is preferred. The lines of the main hips below where the subordinate

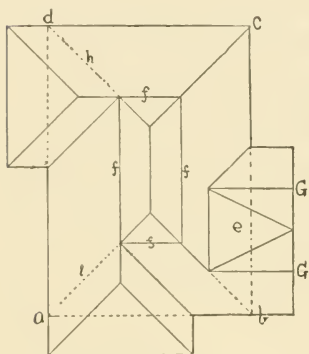

Fig. 76.

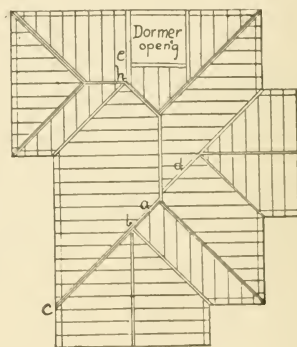

Fig. 77.

ridges intersect them, as at *h* and *i*, should also be erased. If the width of a projection is so great that its ridge would come too high up on the main roof it can be roofed by a double gable, as at *G G*, or two three-quarter gables. The portion of the roof *e* between the gables will, of course, have a much less pitch than that of the gable roofs, but it can not usually be seen from the ground.

Should a deck be desired on the roof it can be indicated by drawing a rectangle, *f f*, between the hip lines at any desired point above the subordinate ridges.

Although the roof plan shown in Fig. 76 is a comparatively simple one, the method used in laying it out can be extended to the most complicated plan, provided the plate is all on the same level. If

part of the roof starts from a different level than the plan must be worked out in connection with the elevations.

**76. Framing Plan.**—After the lines of the roof have been decided upon a plan should be drawn of the framing timbers. In drawing this the first step should be to draw all the hips and valleys and then the common and jack rafters, leaving proper opening for chimneys, dormers, etc. Unless there is some special reason for doing otherwise the common rafters should be drawn perpendicular to the walls or ridge, as this brings a large part of the weight of the roof directly on to the walls, and the boards, being put on horizontally, offer a support or stage for the workmen.

Fig. 77 shows the framing plan of an ordinary house roof, the common and jack rafters being indicated by single lines, spaced 16 inches apart.

The spacing of the common rafters varies much with the custom of the locality; in some places 16 inches is the usual spacing, and in others a spacing of from 20 inches to 2 and even 3 feet is adopted. When the spacing is only 16 inches the rafters are often lathed on their under side, but when over that distance apart they must be furred for lathing. It will require less lumber to obtain the same strength and stiffness in the roof when the rafters are spaced 2 feet apart than when they are only 16 inches apart, even including the furring strips. In Boston the usual spacing for dwellings is 20 inches, and in Denver, Colo., it is 16 inches, but in the latter place the attic lathing is applied directly to the rafters, while in Boston the laths are nailed to furring strips. The Boston method gives the straightest work and the most economical construction as far as material is concerned, but it involves a little more labor than the Denver method.

**77. Details of Construction.**—If the roof is less than 30 feet in span, and the plate is securely tied by the attic floor beams, no interior support will be needed, as the roof can always be framed so as to be entirely supported by the walls. The size of the common rafters should be at least 2x6 inches for lengths of 12 feet, 2x8 for lengths from 12 to 18 feet and 2x10 for lengths over 18 feet. As a rule it is cheaper to reduce the span of the rafters to 10 or 12 feet by using purlins or partitions for supports than to use heavier rafters.

Each rafter should have a bearing on the wall plate of at least  $2\frac{1}{2}$  inches for 6-inch rafters, and 3 or 4 inches for 8 and 10-inch rafters; they should also be securely spiked to the plate.

At the ridge the rafters should be spiked to a plank, as shown in Fig. 75. Very often this plank is omitted, and the upper ends of each

pair of rafters are spiked together, or secured by a short piece of board nailed across the ends, as shown in Fig. 79. While this method gives sufficient strength, it is more apt to give a crooked ridge than the former method.

The upper edge of all hip rafters should be beveled to fit the plane of the roof on each side of it.

If the wall plate is 3 feet or more above the attic floor, the rafters or plate should be tied to the floor beams by inclined braces or ties, as shown in Fig. 78. These ties may be of 1-inch boards, but should be securely nailed at each end with ten-penny nails and spaced not more than 3 feet apart. They should not be placed at a greater angle than  $45^{\circ}$  with the floor beams, and the longer the tie the more effective it will be.

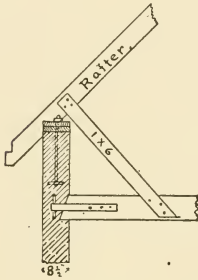

Fig. 78.

In a roof such as is shown in Fig. 77, with an extreme width of the principal rectangle of 30 feet or less, the only pieces which require especial strength are the valley rafters. These timbers have to support nearly all the weight of the roof above them, and should be calculated accordingly. One of each pair of valley rafters should be extended to the main ridge, or to a hip rafter, as shown at *d* or *b*, Fig. 77, and also in Fig. 75, otherwise there would be no support for the upper

end of the valley, unless supported by a post in the attic. In roofs of moderate size, when the main hips are intercepted by a subordinate ridge, as at *h* and *b*, it is customary to stop the hip at the ridge and spike the two together, but in large roofs the hip should be extended to the plate, as at *b c*, and the rafters cut against it.

A roof framed as in Fig. 77 will be entirely self-supporting without interior supports. The hip rafters, in roofs having a secure plate well tied, are supported by the common rafters, and do not need to be of extra size, except that it gives a better chance for nailing and for beveling the top to make them 2 inches deeper than the jack rafters. Openings for dormers should have double or tripple rafters at each side and a header at the top, proportioned according to the width of the opening and the area of roof to be supported.



**78. Size of Special Timbers to be Calculated.**—It is impossible to give any rules for the size of special timbers, such as valleys, headers, etc., either in roofs or floors, other than those for the strength of beams. It is often the custom merely to make such timbers double or tripple the size of the common rafters or joists, but such a practice is not much better than guesswork, and the young architect should early accustom himself to calculate the necessary size of such timbers for the weight they will have to support.

In computing the strength of inclined beams to support a vertical load it will be sufficiently accurate to take the horizontal projection of the beam for the span, using the same formulæ as given for horizontal beams.

*Collar Beams.*—A pitch roof is greatly strengthened by nailing collar or horizontal beams across each pair of rafters at a height of 8 or 9 feet above the attic floor, as shown in Fig. 79. These prevent

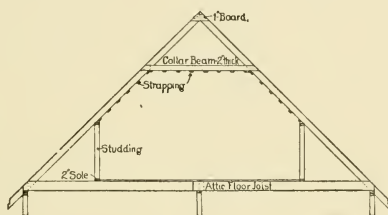

Fig. 79.

the rafters from sagging, and, if the attic is to be finished, will also serve as ceiling beams.

The rafters are also usually strengthened by studding set out 3 or 4 feet from the plate to form the walls of the attic rooms.

**79. Mansard and Curb Roofs.**—The form of curb roof known as the "mansard" roof is supposed to have been invented by Francois Mansard, a distinguished French architect of the seventeenth century. This shape of roof afterward became very common in France, and is therefore often referred to in this country as the "French" roof. Curb roofs were very commonly used on the early Colonial buildings of this country, but they were quite different in their proportions from the French type. The Colonial curb roofs also received the name of "gambrel" roofs.

By means of a mansard or curb roof the same amount of available space may be obtained more cheaply than by means of a gable

roof, and the outward thrust on the walls is not as great with a mansard roof as with a pitch roof.

On the other hand, mansard roofs, where they stop on top of the wall, have the disadvantage that the gutter is not so easily freed from snow, and such roofs are also considered more inflammable than roofs of one-half or less pitch.

The New York and Chicago building laws require that roofs whose inclination with a horizontal is greater than  $60^\circ$  shall be of fireproof construction, except (in New York) on dwellings less than 35 feet in height.

The curb roof is frequently used in this country on dwellings, and particularly on those in the Colonial style. The mansard roof was the prevailing type of roof on pretentious dwellings thirty years ago, but is now little used except on city dwellings built in blocks, and on public buildings, for which it seems to be particularly appropriate.

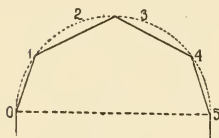

Fig. 80.

As regards the proportion or pitch of mansard roofs there appears to be no recognized rule.

Rivington's "Notes on Building Construction," Part II., gives the method shown in Fig. 80 for determining the outline of the roof. A semicircle is described on a horizontal line connecting the wall plates, and is divided into five equal parts. The chords, 0 1 and 4 5, give the lower lines of the roof, and the upper lines are obtained by drawing chords from 1 and 4 to the center of the semicircle.

If the angles of the roof lay in the line of a parabola, instead of a semicircle, the beams would, theoretically, be in equilibrium; that is, the outward thrust of the upper rafters would be just balanced by the inward pressure of the lower ones, but as any inequality in the loading, or the least wind pressure, would immediately disturb the equilibrium, this consideration is not of much practical importance.

As a matter of fact, the outline of both mansard and curb roofs is generally determined by the consideration of external effect, although the pitch of the upper portion will depend somewhat upon the roof covering, a rise of 6 inches to the foot being the least that should be given to roofs that are to be covered with slate or shingles.

For curb roofs the outlines shown in Fig. 81 may be considered as representative of modern American practice. Diagram *A* is the

outline of one end of the Governor Brooks house, at Medford, Mass., which was built in 1764, and is fairly typical of the roof outlines of that period. Diagrams *B* and *D* are taken from modern Colonial houses having two stories below the roof, and diagram *C* gives the outline of a one-story house designed by Mr. W. R. Emerson, who has been particularly successful with this style of architecture. Diagram *E* shows the outline of the wings of the Garden City Hotel, Garden City, L. I., designed by Messrs. McKim, Mead & White, architects.

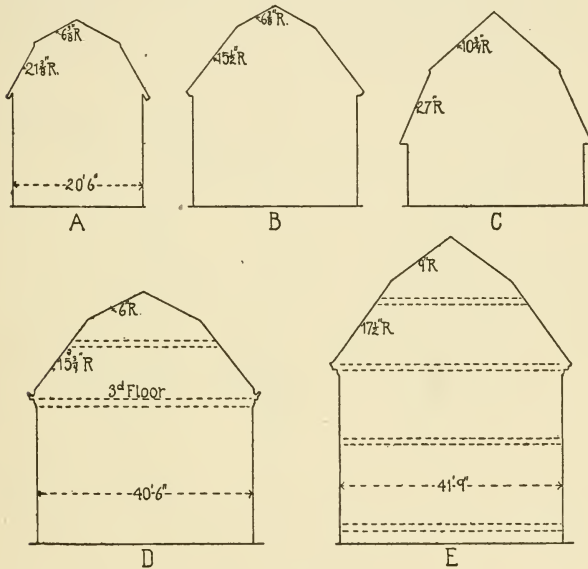

Fig. 81.

The numbers shown in connection with the roof lines indicate the rise of the roof in one foot of horizontal projection.

Diagrams *A*, *B*, *C* and *D*, Fig. 82, and section *C*, Fig. 84, are representative outlines of mansard roofs as used on dwellings in this country thirty years ago, and diagram *E* is typical of the modern mansard roof, the curved outlines being now seldom used.

City houses built in blocks, when surmounted by a mansard or steep-pitch roof, generally terminate in an ornamental cresting, as

shown at *E*, the main roof being covered with tin or grave roofing and pitching toward the rear of the house. Very frequently a balustrade or parapet is placed above the wall cornice and in front of the base of the roof. Mansard and curb roofs are almost invariably pierced by dormers.

**80. Construction of Curb and Mansard Roofs.**—The construction of curb roofs is usually quite simple, the common method being about as indicated in Fig. 83. The wall plate may be either just below the attic joists, as shown, or it may be above the joists, but is seldom more than  $2\frac{1}{2}$  feet above the joists, as it is desirable that the dormer windows shall come above the plate. If the plate is above the attic floor joists, the latter should be anchored to the

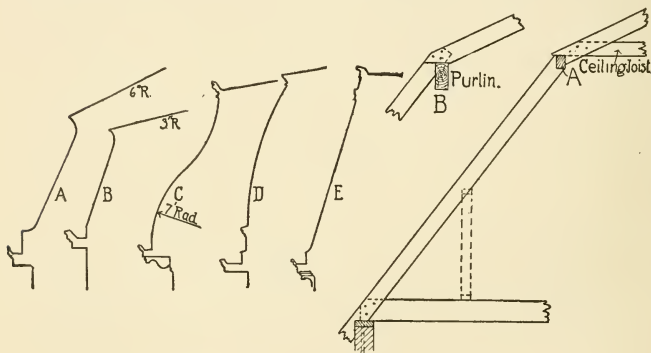

Fig. 82.

Fig. 83.

wall if of brick, or well spiked if of frame, and the wall plate bolted to the wall, or well spiked to the top of the studding if of frame, as the plate is depended upon to resist the outward thrust of the lower rafters.

Where the two sets of rafters meet at the curb, a plate or purlin, at least 4x6 inches, should be placed, and the upper end of the lower rafters cut so that the latter will support the plate; this plate should receive the upper rafters, and, if the height of attic story will permit, the ceiling joist also.

If the attic ceiling comes below the curb plate the rafters may be supported by a purlin, as shown at *B*. These purlins should be tied together across the roof at least once in 14 feet. A roof framed as shown in Fig. 83, and without any cross partitions, would be likely

to collapse under a severe gale or from a heavy weight of snow on one side only; hence, if the roof space is not divided in length by cross partitions, bracing should be employed. As a general thing such roofs are further stiffened by dwarf partitions, as shown by the dotted lines.

The construction of mansard roofs will depend, in a great measure, upon the outline. Fig. 84 shows the construction of two of the most common shapes. In both of these drawings the weight of the roof is carried directly to the wall plate, the 2x4 uprights, in Section C, being considered merely as a partition or furring, which could be entirely omitted if desired. The curve of the roof should always

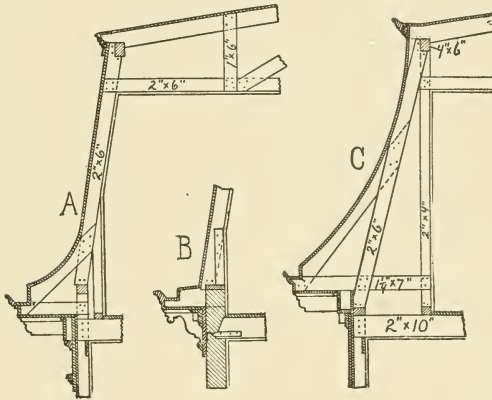

Fig. 84.

be formed on 2-inch furring pieces built out from straight rafters, which should take the weight of the roof and always rest on the wall plate. The wall plates should not be more than  $2\frac{1}{2}$  feet above the floor joist, and should be so secured that they cannot spread.

Mansard roofs are generally accompanied by heavy projecting cornices, which, if of wood, may be formed as shown in Fig. 84. The cornice at *B* is supported by plank "lookouts" built into the wall and secured by spikes driven through the plate. These lookouts may be from 2 to 3 feet apart.

**81. Framing of Conical Roofs.**—Small conical roofs, such as are frequently used on small circular towers, are best framed as

shown in Fig. 85. The plate should be cut out of wide planks, and always made of two thickness put together so as to break joint; when well spiked together, they thus form a continuous ring to resist the outward thrust of the rafters. The rafters should be spaced at even distances apart, about 3 feet at the bottom, and circular ribs cut in between about every 20 inches to 2 feet on the slant. If the diameter is 10 feet or more only part of the rafters need be carried to the peak,

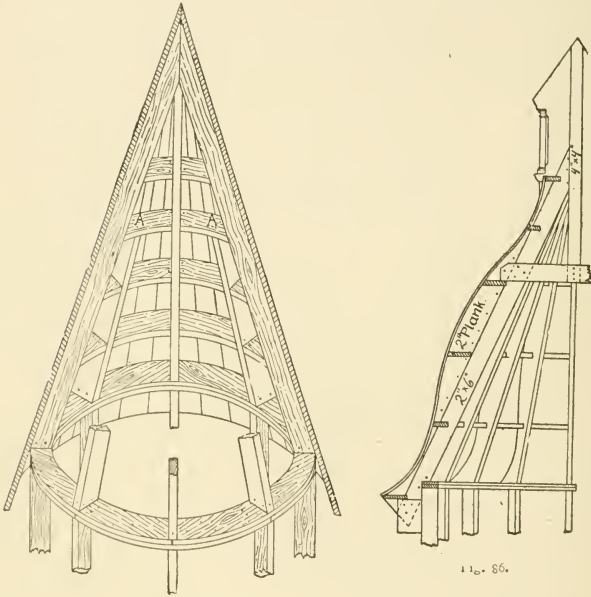

Fig. 85.

the others being terminated under one of the circular ribs, as shown at *A*. For small roofs it is necessary to cut the boards to a wedge shape and put them on vertically, nailing to the circular ribs. Larger roofs may be covered by using  $\frac{3}{4}$ -inch boards and bending them around the roof, at an angle of  $45^\circ$ , with the plate. In this way the boards do not have to be cut to a pattern, and the ribs or sweeps are not required, except for securing the upper ends of the short rafters, as the boards are nailed to the rafters.

*Bell-shaped Roofs.*—If the vertical section of the roof is bell shaped, instead of conical, furring pieces cut to the desired curve should be spiked to the top of straight rafters, as shown in Fig. 86, and circular ribs cut in between, as in conical roofs. If the roof is very high, or has a finial, the upper end of the rafters should cut against a centre pole, having as many sides as there are rafters. This pole stiffens the roof and forms a support for the finial. It is also well to brace the lower end of the pole by cross pieces spiked to the rafters and to the pole.

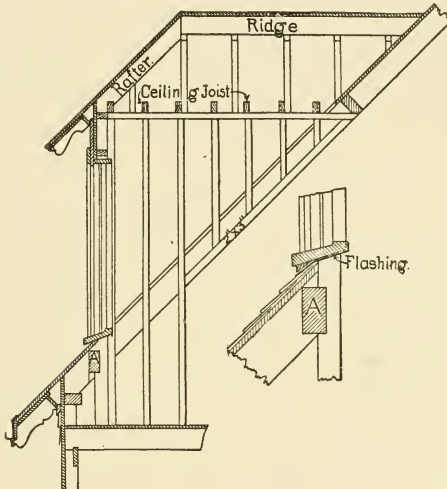

Fig. 87.

**82. Dormers.**—These should be framed as shown in the section drawing, Fig. 87. An opening of the proper size to receive the dormer should be framed in the roof, as shown in Fig. 77, and the studs of the dormer should be notched out 1 inch over the roof boarding and trimmer rafter and extended to the floor. Notching the studding on to the roof prevents the roof from sagging or breaking away from the sides of the dormer and thus causing a leak, and the studding being extended to the floor also stiffens the trimmer and gives a homogeneous surface to lath on, without fear of plaster cracks. An enlarged section through the dormer sill is also given in Fig. 87,

showing the way in which the flashing should be placed. The flashing should be laid over the upper course of shingles, and a wedge-shaped piece fitted between the sill and flashing and toe-nailed into sill. This keeps the flashing in place and nearly conceals it. The upper end of the flashing should be securely nailed to the back of the sill.

On mansard roofs the front of the dormer generally comes over the wall, the front studding thus resting on the wall plate; the studding forming the sides may, in this case, be spiked to the top of the trimmer rafters.

**83. Roofs Exceeding 30 Feet in Width.**—When the span of a roof exceeds 30 feet either trussing or interior supports should be used, so that the unsupported length of the rafters shall not exceed

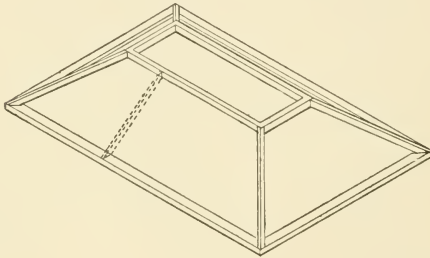

Fig. 88.

12 feet. The roofs of dwellings can generally be sufficiently supported by carrying up partitions and by the use of collar beams. It often happens, however, that it is desired to use the attic space in a large house for a ball room or for some similar purpose in which posts or other supports for the roof would be very objectionable; in such cases the roof can generally be supported in the following manner:

*Hip-Roof Trussing.*—Any room not exceeding 40x60 feet can be safely covered by a hip roof without trusses or interior supports of any kind, provided the plate can be made continuous around the four sides of the main roof. Fig. 88 represents the plate, hip rafters and deck beams of a hip roof, terminated by a deck. It can readily be seen that such a construction is practically a truss in itself, and if the



several pieces are properly proportioned and connected it will carry an enormous weight and exert only a vertical pressure on the walls.

As ordinarily constructed the hips and plates of such a roof are made light and practically do not carry any load at all, but if all the common and jack rafters were spiked to the deck beams and hip rafters, so securely that there would be no tendency of the rafters to slide or push out at the bottom, the whole weight of the roof would then be thrown largely on the hips, and there would be no outward thrust on the plate. The thrust of the hips would be taken up by the plate and the walls under the plate would sustain the vertical load. The hips and deck beams must be of such size that they will not sag under their load, and the planks forming the plate must be fastened so securely, by tie irons at the angles, that the hip rafters cannot force them apart. No dependence should be placed upon the common rafters for supporting the hips and deck beams. If it is desired to carry the roof to a ridge it can be extended above the deck beams, the latter forming a new plate, as it were. In such a case, however, there should be collar beams between the deck beams to prevent their being pushed in.

Such a roof is entirely practicable, and the author has often employed this principle in constructing hip and octagon roofs. If carefully built and proportioned this construction can be used where there is no ceiling at the plate level, but in such cases the plate should be made as wide as possible and not less than 12 inches when 30 feet long. It is obvious that if the angles of the plate should give way the whole roof would fall.

If there are projections and minor roofs they can be built on to the main roof and will strengthen it against spreading, but the main frame must be built as in Fig. 88, with the plate *continuous* around it. If the plate is interrupted by chimneys, it should be connected by iron ties, passing either through or around the chimney.

84. *A Simple Method of Roof Bracing.*—When it is desired to support the rafters of a roof without using trusses, a method of framing, such as is shown in Fig. 89, can often be adopted with advantage. Purlins are placed under the centre of the rafters, and these are supported by braces as shown, and pieces of boards or plank are nailed to the rafters and against the purlins, as at *A*. The braces should be spaced about 8 or 10 feet apart and the purlins proportioned according to the length of the rafters and distance between the braces. If there are no ceiling joists then tie-beams must be used, spaced the same distance apart as the braces, to keep

the plates from spreading, and the plate must be of such width that it will not bend horizontally between the tie-beams. Such construction is well adapted for the roofs of pavilions, depot platforms, etc., when the span is from 30 to 35 feet, and centre posts are not objectionable.

**85. Superintendence of the Frame Work.**—*Wooden Buildings.*—If complete framing plans have been furnished for the walls, floors and roof, the superintendence of this part of the work will be quite an easy matter, as the work is fully exposed and open to inspection.

*The Lumber.*—The first point to be attended to is the inspection of the lumber, to see that it is of the kind and quality specified and of the proper dimensions. The superintendent should be sufficiently

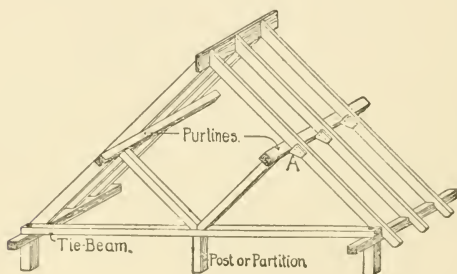

Fig. 89.

familiar with the various woods specified to distinguish the different kinds at a glance. The difference in the texture or color of white pine, Norway pine, Oregon pine, hemlock, spruce and hard pine is usually sufficient to readily determine the kind of wood, although there will occasionally be pieces of hemlock which it is hard to distinguish from spruce, and Norway pine sometimes resembles white pine quite closely. If one is familiar with the peculiar odors of these different woods, it will often help in distinguishing them, a fresh sliwer being cut for the purpose.

To distinguish the different varieties of spruce and hard pine is not so easy, and if two varieties of the same species are in the market, one of which is particularly desired, it will probably be necessary to ascertain from the lumber yard which variety was furnished or to call in expert advice. The defects to be looked for are shakes,

longitudinal cracks, bad knots, and pieces that are badly warped Shakey pieces (see Section 17) should always be rejected. Small longitudinal cracks in large timbers are to be expected; they do no very great harm, especially if in the top or bottom of the timber; in thin pieces, such as 2-inch joists, however, longitudinal cracks, especially if below the centre, are sufficient cause for rejection. Pieces that are badly warped should be rejected and also pieces with large or dead knots. Small sound knots are admissible in ordinary framing lumber, as it is difficult to get such lumber that is free from them. Large timbers, with a considerable proportion of sap wood, should not be used where they are subject to great strain, or where ample ventilation is not afforded.

In regard to size, framing timber will generally measure from  $\frac{1}{4}$  to  $\frac{1}{2}$  inch scant of the nominal dimensions, and such difference must be expected and allowed, unless one cares to pay for having the lumber sawn to order.

*Bedding the Sill.*—The first step in the erection of the frame of a wooden building is the placing of the sill, and the superintendent should see that it is properly bedded in mortar if on a brick or stone wall. It is good practice, although not a common one, to paint the bottom of the sill before laying to keep out the dampness, the sides and top being left unpainted for the moisture to dry out.

*Size and Position of Openings.*—As the framework progresses the superintendent should verify the principal dimensions to see that they agree with the drawings, for, while the builder can be held responsible for his mistakes, it is very annoying, to say the least, to discover after the frame is up that the building does not correspond with the plan, and the owner is usually inclined to think that the architect should have prevented the error.

The most frequent mistakes that occur are in locating the door and window openings, and those for the chimneys. The openings for the chimneys, especially, should be measured to see that they are large enough for the chimney to pass through without coming within 2 inch of the headers and trimmers. They should also be exactly located, as the variation of an inch will often affect the appearance of the room to which they belong.

*Support for Partitions.*—When the floor joists are being placed the superintendent should see that the timbers which are to support partitions are of the designated size and put in their proper places. He should also look at the framing around all openings to see that the

header and trimmers are of the proper size, and that the pieces have been properly mortised together, or supported by stirrups, whichever way may be specified.

*Plumbing, Mortising, etc.*—While the outside frame is being erected the superintendent should see that the posts are plumb, the girts placed at the proper height, all the braces put in, and the whole properly mortised and pinned together.

*Roof.*—The principal points to be looked after in the roof frame are the pitch, the way the valley rafters are put in, and the size and position of the dormer openings.

Carpenters are sometimes liable to get the pitch a little less than that indicated on the drawings, as the flatter the pitch the less lumber is required, hence the necessity of seeing that the pitch is the same as that indicated on the drawings. It can easily be determined by means of a two-foot rule and a plumb.

The superintendent should also see that the valley rafters are extended to the ridge, or to a hip, as explained in Section 77, as this is not always done.

In order that the studding of the dormers may be notched on to the rafters, as explained in Section 82, it is necessary that the trimmer rafters be spaced very accurately, and the superintendent will do well to carefully verify the measurements.

All parts of the roof should be well spiked together, and particularly at the plate, ridge, hip and valleys. The ridge should be perfectly straight and level and exactly in the centre. The tops of the rafters should also all lie in the same plane and not be hunched up or sagging.

*Partitions.*—The superintendent should see that all partitions are set in their proper place, and that the studding is straight and plumb and of uniform width. Crooked studding may be straightened by cutting with a saw on the bulging side and then spiking together, or the stud may be cut in two and a cross piece or header put in between the adjacent studs. The bearing of the partitions should be examined to see that it corresponds with the specifications, and the superintendent should see that the studs at the sides of the door openings are strongly supported. Very often such studs, which, if in a bearing partition, are quite heavily loaded, will come over the centre of the space between the studs below, the whole weight, perhaps, being borne by a 2x4 cap. In such a case a brace should be put in below or the plate reinforced. The superintendent should also examine all corners to see that they have been made solid for lathing.

and see that provision is made for running furnace pipes and that all openings are properly trussed.

*Bridging.*—As soon as practicable after the floor joists have been placed, and before the under flooring is laid or the partitions built, the floor bridging should be put in and securely nailed with two ten-penny nails in each end of each piece.

*Brick Buildings.*—The framing of the floors, roof and partitions of brick buildings is the same as for wooden buildings, with the exception of the wall plate and the anchoring of the floor joists. As has been explained in Sections 54 and 55, the anchoring of the floor joists to the walls in brick buildings is a very important matter, and should be carefully looked after by the superintendent, who should also see that the bolts for the wall plates are built into the wall at the proper height. If the partition studs are to be bolted to the wall the superintendent should see that they are provided by the carpenter and built in by the brick mason at the proper time, otherwise they are very apt to be overlooked.

While many of these points seem very simple, unless the superintendent fixes them well in his mind and realizes their importance, he will be likely to find, as the building progresses, that he neglected to look after them at the proper time, and that some things have been overlooked or not properly done that he might, by a little thought and care, have had done properly. If, as is the usual custom, the architect supervises his own work, inspecting it once every day or every second or third day, as may be required, he will find it a great aid in his work to make a memorandum from the specifications before visiting the work of the things to be looked after, and then examine them in order when he is at the building.

### CHAPTER III.

## SHEATHING, WINDOWS AND OUTSIDE DOOR FRAMES.

**86. Rough Boarding.**—*Wooden Buildings.*—As soon as the walls of a frame building are up they should be slightly covered with common boarding, or “sheathing” as it is called in many localities. For this purpose the cheapest kind of lumber may be used; hemlock, spruce and Western white pine being most commonly used in the North, hard pine in the Gulf States, and red wood and Oregon pine on the Pacific coast. For the better class of buildings the boards should be dressed on one side to bring them to a uniform thickness, and they should be free from shakes and large knot holes.

When the braced frame is used it is customary to sheath the first story before the second story studding is set up. The sheathing or boarding should be nailed at each bearing with two ten-penny nails, although eight-penny nails are often used. If the building is built with a balloon frame, without braces, it is necessary to put the boarding on *diagonally* in order to secure sufficient rigidity in the frame. With the braced frame diagonal sheathing is not necessary, although it makes a better job than when laid horizontally, and all towers, cupolas, etc., should be sheathed in this way.

*Roof Boarding.*—In covering the roof either of wood or brick buildings two different methods are pursued: in the first the roof is tightly covered with dressed boarding, like the walls, and in the second narrow boards, sometimes called “laths,” are nailed to the rafters horizontally, and with a space of 2 or 3 inches between them. The latter method is considered to make the more durable roof, as it affords ventilation to the shingles and causes them to last longer. But if the attic is to be finished such a roof is very hot in summer and cold in winter, and most architects prefer to cover the roof with boarding laid close together and then lay tarred paper over the boarding and under the shingles or slate; this not only better protects the attic space from changes in temperature, but also prevents fine snow from sifting in under the slates or shingles. The specifications should distinctly mention whether the boards are to be laid close together or laid open, as well as the kind and quality of the boards.

For shingle roofs it is not absolutely necessary that the boards be dressed one side if they are of a uniform thickness, but the dressed sheathing makes a neater job and costs but a very little more.

Roofs that are to be tinned should be covered with *matched* boards, dressed one side, so as to give a smooth surface for the tin, and all knot holes should be covered with a piece of heavy galvanized iron. All rough edges should also be smoothed off with a plane. The necessity for these precautions is to prevent the tin being injured by the turned up edges of the boards when walking on the roof, or breaking through where the knot holes occur.

**87. Outside Frames.**—The first carpenter's or joiner's work usually required in connection with either a frame or brick building

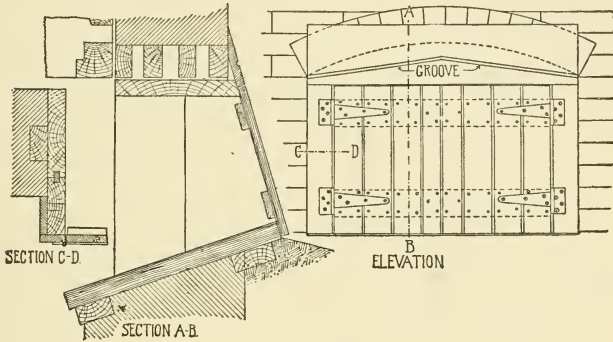

Fig. 90.

is the making of the basement window frames, coal chute, and outside basement door frames, if there are to be any, as these are generally built into the wall as it progresses.

**Coal Chute.**—As nearly every house that is heated by hot air, steam or hot water must have a coal bin in the basement, an opening for putting in the coal is a necessity. Very often an ordinary cellar window is utilized for this purpose, but where there is room it is better to construct a regular coal chute, as the ordinary window frame soon becomes marred and gets loose and the glass is frequently broken. Especially is this the case where soft coal in large lumps is used.

The author has found the construction indicated by the section and elevation drawings, Fig. 90, the most satisfactory and durable, and it presents a fairly neat appearance. The frame is made entirely

of plank, those forming the bottom running *across* the wall instead of longitudinally with it, as in the sill of a window frame. The bottom of the frame should project 6 inches beyond the outside of the wall, so that the doors may have a slope outward, and also to afford greater facility in putting in the coal. The outside of the plank frame should be cased with  $\frac{3}{4}$ -inch finished lumber, as shown in section *CD*, and the doors made of ceiling,\* strongly battened and put together with screws or clinched nails. They should be hung with T-hinges, and may be fastened with hooks and staples on the inside. Pieces of studding should be nailed to the ends and bottom of the frame to hold it in the wall.

**88. Cellar Window Frames.**—These are almost invariably

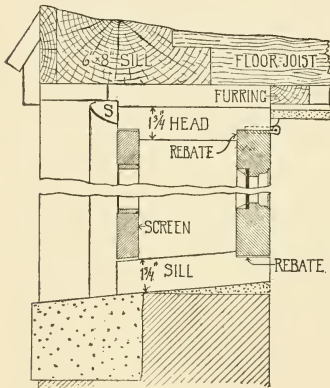

Fig. 91.

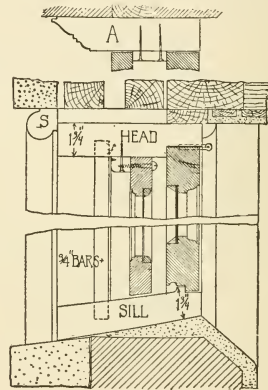

Fig. 92.

made of planks, and are usually fitted with a single sash from 16 inches to 2 feet in height and from 30 inches to 3 feet wide, hinged at the top to open in.

Fig. 91 shows sections through the sill and head of a cellar window of a frame house, as ordinarily constructed, although in the very cheapest work the jambs and heads are sometimes made without rebates, a strip called a "stop" being nailed to the frame for the sash to strike against. A moulding, *S*, is generally nailed to the outside edge of the frame to make a closer joint between the frame and the

\* The term "ceiling" as used in this book refers to matched and beaded boards; in Boston and possibly elsewhere, the term "sheathing" is used to denote the same thing.



mason work. This moulding may be of various shapes, but a better joint is made by having a quirk on the outer edge. In all frames built into stone or brickwork this moulding is called the "staff-bead," or, in some localities, the "brick mould." The head and sill should project beyond the sides or "jambs," so as to form lugs for securing the frame to the wall, and the jambs should be let into them  $\frac{1}{4}$  inch.

The frame shown in Fig. 92 shows a better construction in one or two respects. The most important of these is the shape of the sill, which makes a tighter joint than that shown in Fig. 91. This frame is also provided with vertical iron bars, placed about 4 inches apart, as a security from burglars, and the fly screen is put in from the inside. The sides of the frame have the same section as the head.

The detail at *A* shows a section sometimes used for the jambs and head of cellar frames. Where the jamb is in one piece, however, it is apt to warp away from the masonry, and, in the opinion of the author, is not as good construction as where a separate staff-bead is used. It is a good idea with all plank frames to nail 2x2-inch strips to the back of the jambs, as shown at *A*, for holding the frame securely in the wall.

**89. Types of Windows.**—Before proceeding further with the details of window construction, it may be well to consider briefly the various types of windows commonly found in American buildings.

The most usual style of window in this country is the "double hung" window, which has two sash, each one-half the height of the window and each hung with cords and weights, to slide up and down. The essential features of this window are the same in both frame and brick buildings, although the difference in the character of the walls necessitates some difference in the construction of the frames.

Drawing *A*, Fig. 93, shows an elevation of a double hung window in a frame building, with two styles of head finish, and drawing *B* shows an elevation of the same window placed in a brick wall.

There are also several variations of this type of window, a very common one in brick buildings being that shown at *C*. Where the window has a circular head there are two methods of constructing the upper part of the frame and sash. One is to make all but the outside portion of the frame square, with square solid corners to the upper sash, so that it will slide up and down, and be finished on the inside the same as if the window had a square head. The other method is to make a solid circular head to the frame, so that it will finish circular on the inside. The latter method generally gives the

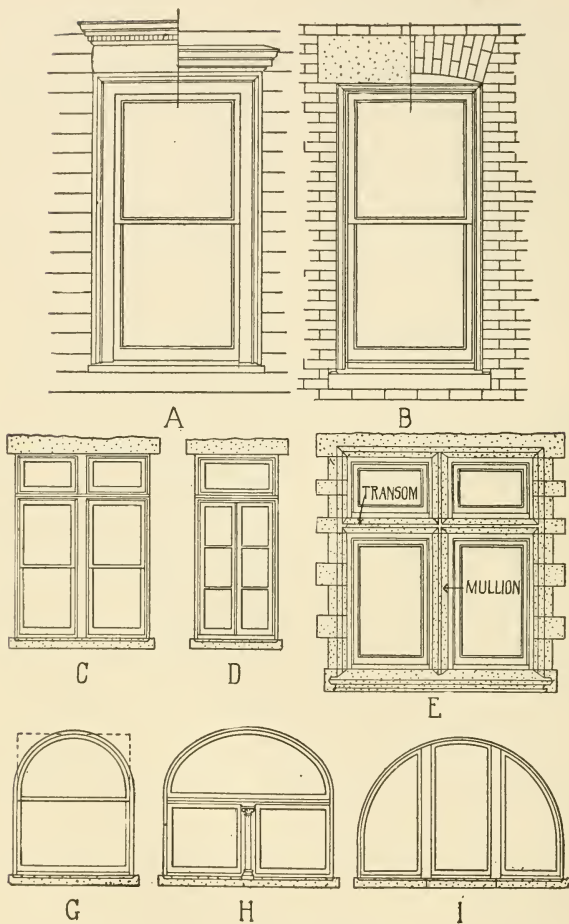

Fig. 93—Types of Windows.

better appearance on the inside, especially where there are no curtains or draperies to the window, but it has a serious objection in that

the lower sash can only slide to the springing of the circle, and the upper sash, having but a small portion of its sides straight, does not usually work well. For these reasons it is generally better to adopt the former method of construction for circular head windows in residences, hotels, club buildings, etc.

Frequently in brick buildings the top of the upper light of glass, and also the outside of the frame, is cut to a segment of a circle, in which case it is called a "segment head" window. Segment head windows are usually finished square on the inside.

Double hung windows are also often made with the division between the sashes at some point above the middle, so as to bring the meeting rail above the height of the eye when looking from the inside; when this is done it is necessary to make a pocket above the head of the frame for the lower sash to slide into, if it is to slide its full height.

Double hung windows are also frequently used in pairs, as shown at *C*, and sometimes three or four windows are included in the same frame. A window such as is shown at *C* is called a "mullion" window or a double window, the vertical division between the windows being called a "mullion." This window also has a "transom," which is the horizontal division between the double hung sash and the small sash, or "transom lights," above. Transoms are frequently used where there are no mullions, and *vice versa*.

Stone mullions and transoms are also frequently used to divide windows, as shown in drawing *E*, which also represents a special type of the double hung window.

Next to the double hung window, in regard to general use, comes the casement or "French" window shown at *D*. This window has the sashes divided vertically, each being hinged at the sides like a pair of doors. Transoms are frequently, although not necessarily, used with this style of window. The casement window is the common type of window in Europe, but it has serious objections which make it undesirable for general use. The most important of these objections are that if the sash swings in, it is difficult to make them storm proof, and they also interfere with the shades and draperies, and if they swing out, fly screens cannot be used on the windows.

Besides these two types of windows there are also several varieties of windows in which the sash are pivoted, either at the centre of the sides or at the top and bottom. Windows of the shape shown at *L* are frequently seen in large buildings. The sash in these windows, if they open at all, are usually pivoted top and bottom.

Then, there are the tracery windows used in churches, which may be of a great variety of shapes and proportions.

**90. Construction of Windows.**—*Material.*—In general a window may be said to consist of three parts—the frame, the sash and the inside finish—and each part is usually described separately in the specifications. The material for all those portions of the frame which are exposed to the weather should be clear Eastern or Northern white pine, sugar pine, cypress or red wood, white pine being generally preferred.

The piece called the “pulley stile” is frequently made of hard pine, and sometimes of hard wood, because such woods wear better under the friction of the sash in sliding up and down. Whether of hard or soft wood, the pulley stile should never be painted, but simply oiled or stained.

The concealed portions of the frame are usually made of spruce, the cheaper grades of white pine, or of the most common wood of the locality. All of the material should be well seasoned, and frames that are to be placed in masonry walls should be painted or oiled *all over* before they are set to keep out the dampness.

Occasionally the window frames of public buildings are made of cast iron, and quite frequently in office and mercantile buildings the outside of the wood frame is covered with cast bronze or bronze plated iron.

**91. Details of Double Hung Window Frames.**—*Windows in Frame Buildings.*—The common method of constructing the window frames in wooden buildings is shown by horizontal and vertical sections in Fig. 94. Such frames are frequently called *skeleton frames* in distinction from the box frames used in brick and stone buildings. The essential parts of such a frame are the pulley stile, *A*, the parting strip, *E*, the outside casing, *B*, the stop bead, *S*, and the head and sill. A band moulding, *C*, sometimes called the “outside architrave,” is also necessary if the casing is flush with the boarding, but where it sets outside of the boarding the moulding is often omitted. The inside casing or trim, *D*, is a part of the inside finish, and not usually considered as a part of the frame. Very frequently, in cheap work, the tongue on the outer edge of the pulley stile, at *R*, is omitted and the casing, *B*, simply nailed to the pulley stile. This tongue, however, is a very important feature, as it prevents the pulley stile from warping or springing, and permits the sash to slide more freely.

The construction shown in Fig. 94 may be considered as the very cheapest, and is not recommended for good work.

In all first-class dwellings the sill should be made of the shape shown in Fig. 95; that is, with a rebate at *K* for the bottom rail of the sash to shut against, and a ground casing, *G C*, should be nailed to the inside edge of the pulley stile. It is not common, however, for builders to include these two features unless they are specified. The ground casing stiffens the pulley stile and keeps it straight, and gives a better nailing for the finish. If  $1\frac{3}{4}$ -inch sash are to be used, as is desirable in first-class work, and the studding is 4 inches wide, the outside casing should be placed outside of the boarding, so as to give a wider pulley stile. This also gives room for a strip, *S*, to which the guide for the fly screen, *F*, may be fastened. When there

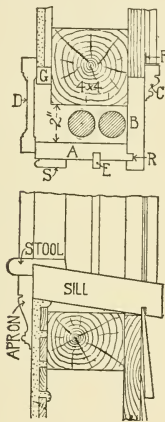

Fig. 94.

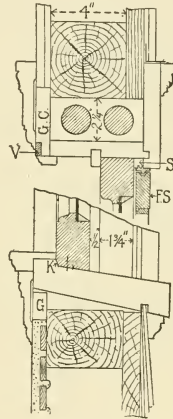

Fig. 95.

are to be outside blinds, with swivel slats, and also outside fly screens, some such arrangement as this is almost necessary. If the inside finish is to be of hard wood, the ground casing should be rebated for a thin strip, *V*, which should be put in after the plastering is dry. With the outside casing set outside the boarding the band mould or architrave is not really necessary, unless  $\frac{3}{8}$ -inch shingles are used on the walls, but it relieves the plainness of the frame, and is generally used on good work.

In frames made as in Fig. 95, it is also desirable to hang a "pendulum" or thin partition between the weights to prevent their interfering in passing up and down. This pendulum is made of a

strip of  $\frac{3}{8}$ -inch pine, as shown in Fig. 98, and is hung from the top so that it may be swung to one side for getting at both weights through one pocket. In all double hung window frames a piece about 18 inches high and  $2\frac{1}{4}$  inches wide, with beveled ends, should be cut out of the lower part of the pulley stile to give access to the weights. This piece is called the "pocket," and is held in place by a screw at the lower end, and by a brad, or dove-tailed arrangement, at the upper end.

Fig. 96 shows a section through the head and sill of a still more elaborate frame. The sill has an additional rebate under the sash, with the idea of preventing the lower sash from getting "stuck," and also of keeping out rain and snow. This rebate is seldom seen, however, except, perhaps, in a few localities. The rebate at *N* is intended to form a stop for the bottom of the blinds, and is a desirable feature. This detail shows a heavy outside architrave, the inner edge being flush with the blinds and forming a rebate for them to shut into. This construction gives a very neat finish to the window. This detail also shows a different arrangement of the window stool, which is dropped  $\frac{1}{2}$  an inch below the top of the sill and the stop bead carried across the sill. This makes a neat finish, but does not give as wide a stool as the construction shown in Figs. 94 and 95. If the finish is to be painted the sill is brought flush with the inside of the ground casing, and the piece *V* is omitted. With

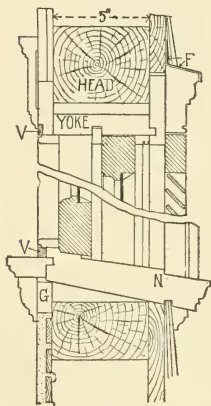

Fig. 96.

hard wood finish the stop bead and the piece *V* are made of the same wood as the finish. In first-class buildings the stop bead should be fastened with round headed screws, which may be of any desired finish; in common work they are fastened with small finish nails.

*Thicknesses.*—All parts of the window frame except the sill and yoke are commonly made of  $\frac{3}{4}$ -inch stuff. For large windows the pulley stiles should be  $1\frac{1}{8}$  inches thick, and if no strip is inserted between the outer sash and the casing, the latter should also be  $1\frac{1}{8}$  inches thick. In wooden buildings the sill should always be at least  $1\frac{3}{4}$  inches thick. Sometimes a sub-sill is placed under the regular sill, but this is not common, and in ordinary construction has no

advantage. The parting strip, *E*, is usually made  $\frac{3}{8}$  of an inch thick for  $1\frac{3}{8}$ -inch sash, and  $\frac{1}{2}$  inch thick for  $1\frac{1}{4}$  or  $2\frac{1}{4}$ -inch sash. The yoke is made from  $\frac{1}{4}$  inch to  $1\frac{3}{4}$  inches thick, according to the custom of the locality. A thickness of  $1\frac{1}{8}$  inches is just as good as  $1\frac{3}{4}$  inches. The stool moulding is generally made  $\frac{3}{8}$  inch thick in moderate priced houses in the Eastern States, but in the West  $\frac{3}{8}$ -inch boards are very seldom thicker than  $\frac{3}{4}$  of an inch when dressed, and  $1\frac{1}{8}$ -inch stools are used there altogether. The depth of the weight box should be 2 inches for  $1\frac{3}{8}$ -inch sash of moderate size; for plate glass windows, and large windows with double strength glass, the minimum depth should be  $2\frac{1}{2}$  inches.

**92. Sheathing Paper and Flashing.**—When the outside casing is set flush with the boarding the band mould or outside architrave, *C*, should be put on after the frame is fixed in place, and the sheathing paper should be extended on to the casing and *C* nailed over it, and also over the joint between the casing and the boarding. If the casing sets outside the boarding the sheathing paper should be put on around the opening before the frame is set and the outside casing nailed over it.

*Flashing.*—When the band moulding or the casing is tightly nailed over sheathing paper no flashing is needed on the sides when the wall is covered with siding or clapboards, and if good thick and tough paper is used it may be omitted for shingles, although it is much safer to flash each course of shingles with pieces of tin, as shown in the figures. The top of the frame, however, should always be flashed, no matter how the frame is made, unless the shingles project over the casing. The best materials for this flashing are lead or zinc, although tin is often used. The flashing should be turned over the edge of the casing or band moulding, as at *F*, Fig. 96, and securely tacked or bradded. The bottom of the sill should be rebated for the shingles or clapboards, as shown in the figures.

**93. Double Hung Window Frames in Brick Walls.**—About the only difference in the construction of the window frames in a brick building from those in a wooden building, is that an additional board, *B L*, Figs. 97 and 98, is nailed to the back of the frame to form a box for the weights, and a moulding or strip, *S*, is nailed to the outside casing to make a finish with the brickwork. From the fact that a complete box is formed for the weights, frames made as in Figs. 97 and 98 are commonly called "box frames." The pulley stile, *P*, and outside casing, *O C*, are the same as in a wooden building, and so also is the yoke. The sill of box frames, where

stone sills are used, is frequently made as thin as  $1\frac{1}{4}$  inches, and the outside edge is generally set flush with the outside of the outside casing. In cheap work, also, the rebate in the sill at *R* is often omitted. In all good work, however, the sill should be at least  $1\frac{3}{8}$  inches thick, and always rebated. A thickness of  $1\frac{3}{4}$  inches is desirable in large windows, and in some localities the wood sills are made as thick as  $2\frac{1}{4}$  inches. Some architects also show the sills projecting to the outer edge of the staff bead, *S*, but in the author's opinion there is no advantage in this, except that a narrower stone sill

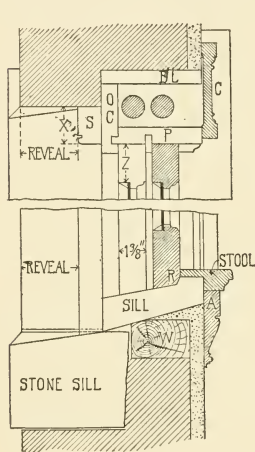

Fig. 97.

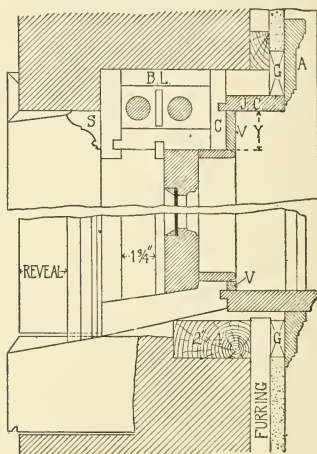

Fig. 98.

may be used, and a wide sill is more apt to "curl up" than a narrow one.

The piece, *S*, is called the "staff bead" in the Eastern States, and is there usually made of the general shape shown in Fig. 98, although a three-quarter bead is frequently used. Staff beads are generally worked out of  $1\frac{3}{8}$ -inch stuff. In the Western States this piece is more generally termed a "brick mould," and for dwellings and ordinary brick buildings it is commonly made of the shape shown in Fig. 97,  $1\frac{1}{8}$  inches thick and 2 inches wide. When this shape of the staff bead or brick mould is used, the piece, *O C*, is sometimes called the "blind stop," but its more general name is the outside casing. The



section of brick mould shown in Fig. 97 is best adapted to windows that are to be fitted with outside blinds. The board, *B L*, is called the back lining.

The distance, *X*, Fig. 97, may be varied to suit the taste of the designer, but is most commonly made 2 inches. The distance, *Z*, is also generally made 2 inches, so that when *X* and *Z* are each 2 inches, the width of the opening will be just 8 inches more than the width of the glass for two-light windows, which is very convenient in figuring the plans and taking off the length of the sills and caps.

In an 8 or 9-inch brick wall the frame is usually set so that the inner edge of the pulley stile will just come flush with the plastering, and with  $1\frac{3}{4}$ -inch sash it is generally necessary to clip the backs of the front bricks. In thicker walls the outside casing is generally set in just the width of a brick, and sub-jamb and casings used, as shown in Fig. 98.

If a 9-inch wall is furred, there will be plenty of room for  $1\frac{3}{4}$ -inch sash without clipping the bricks, and also for a ground casing, the same as shown on the frame in Fig. 95.

The piece, *J C*, Fig. 98, is called the "sub-jamb," or "jamb casing," the latter term being perhaps the more common. The piece, *C*, is sometimes called the "sub-casing," or "inside casing," but the term "box casing" would appear to be better, as it can then not be confounded with the piece *A*, which is also called the casing in many localities.

The covering piece, *V*, is only used where the finish is to be of hard wood, or to be varnished. It has no specific name, but is generally called a veneer. The etched portions of the drawings in these figures (with the exception of the sash and wall) belong to the inside finish. The distance, *Y*, Fig. 98, may be varied from  $\frac{1}{2}$  to  $3\frac{1}{2}$  inches, but is commonly made about  $2\frac{1}{2}$  inches. Under the sill of all box frames a piece of joist should be built into the wall, to which the wood sill may be nailed, and to receive the ground, *G*, or the apron, if there is no ground.

The thickness of the various parts of a box frame are usually the same as for a skeleton frame, except that the sill is sometimes made thinner, as above noted. For large windows, and in first-class buildings, the outside casing should be  $1\frac{1}{8}$  inches thick, and also the pulley stile.

Fig. 99 shows sections through the sill and jamb of a style of window that is quite common in some parts of Pennsylvania, where it is known as a "plank front" frame. This frame shows little reveal,

and is frequently used without an outside lintel, the outer brick being laid on top of the frame, which, as may be noticed, is quite heavy.

This detail also shows a wood sill, which, while not as durable as a stone sill, will last for a long time if kept painted. The detail also shows paneled shutters on the outside of the window. These shutters are quite common in old work; they were usually made with flush panels on the outside, and moulded on the inside. If either shutters or blinds are used on the outside of a window in a brick wall, the hinges should be of such a shape that the shutters or blinds will open back flat against the face of the wall. Where box frames do not set

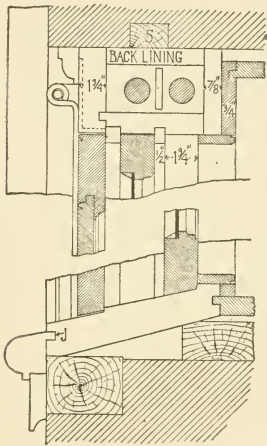

Fig. 99.

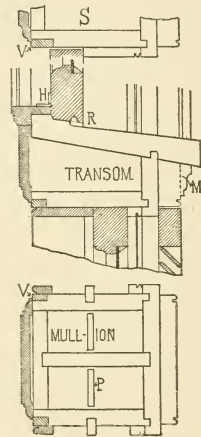

Fig. 100.

into the wall, a piece of wood, about  $1\frac{1}{2} \times 2$  inches, should be nailed to the back lining, as shown at *S*, Fig. 99, to keep the frame from being pushed in or out.

**94. Details of Mullions and Transoms.** — Fig. 100 shows the usual method of constructing the mullions and transoms of double hung frames in wooden buildings, the details given being adapted to the frame shown in Fig. 96. The outside architrave is continued under the sill of the transom, and the moulded part, *M*, may be cut into dentiles if desired. The transom sash is shown over the inner of the sliding sash, which is the best position where the sash

is to open. The best way of opening transom sashes is to hinge them at the bottom, as shown at *H*, as the joint can be made quite tight in this way, while if they are hinged at the top, it is difficult to make the lower joint weather proof. The groove in the bottom rail of the transom sash, and the rebate in the sill, as shown at *R*, are desirable features. Mullions are commonly made the same as a double jamb,

with a partition in the middle to separate the weights. For  $1\frac{3}{4}$ -inch sash, hung with round weights, the least width of a mullion between outer faces of pulley stiles should be 7 inches. The partial section at *S* is taken through the pulley stile above the transom.

Fig. 101 shows sections of box frames adapted to stone transoms and mullions, wooden transoms and mullions in box frames being constructed essentially as shown in Fig. 100.

Where stone or brick mullions are used, a separate frame is required each side of the mullion, but the stone transom usually projects only through the outside casing, the jambs or boxes extending the full height of the window. The upper section in Fig. 101 is taken through the side of the frame above the transom. The transom sash, if stationary, may be put next the outside casing, but if it is to be hung at the bottom, the best place for it is at the inside of the frame, as shown in the figure.

In Fig. 101, a panel set flush with the box casing veneer is shown for the finish of the mullion, but if preferred,

the mullion boxes may be finished the same as the jambs, with sub-jambs extending to the face of the plaster. The method shown, however, obstructs the light less and gives the appearance of one window, while the boxed mullion gives the appearance of two or more windows set side by side. When the stone mullion is not as thick as the wall, steel beams should be placed over the window to

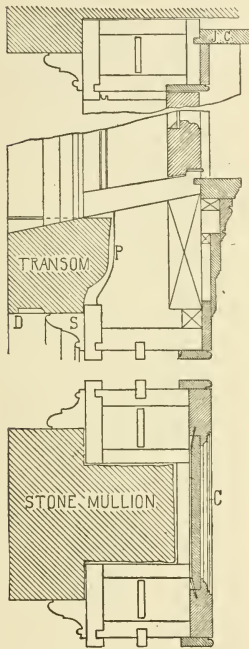

Fig. 101.

carry the weight of the wall above. The "reveal" of a window has no effect upon the construction of the frame, but the greater the reveal the less will be the depth of the inside finish.

95. **Transom Frames with Single Light Below the Transom.** — *Type E.* — The type of window shown at *E* (Fig. 93) is

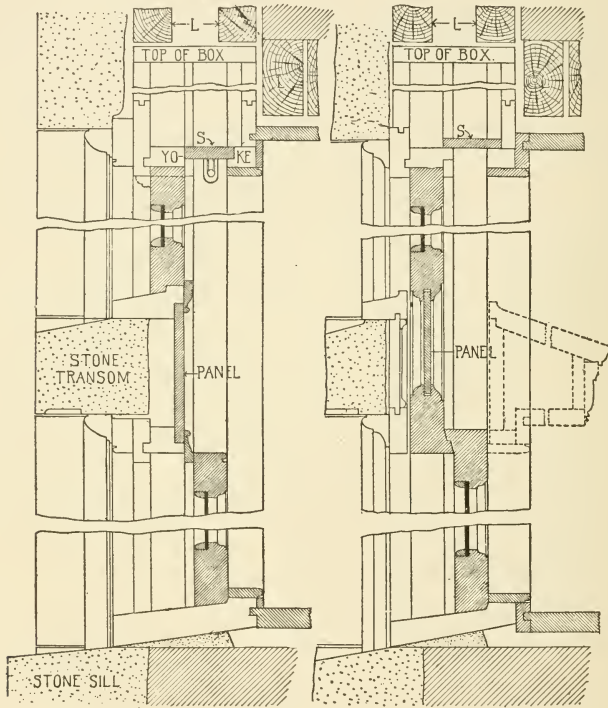

Fig. 102.

Fig. 103.

now quite frequently used in this country, both with and without the mullion. It differs from the ordinary transom window in having only one sash below the transom, thereby necessitating an entirely different construction of the frame. Such windows, to be of practical

utility, should be constructed so that the lower sash will slide up a distance equal to its height, or nearly so, and the transom should be accessible for cleaning the outside of the sash.

Two quite different methods of construction are shown in Figs. 102 and 103, both of which have the same appearance from the outside. Both frames are constructed with boxes at the side for weights, as in an ordinary box frame, and the lower sash in both is operated exactly as in a double hung window, except that a pocket is required above the yoke to permit the sash to slide up the full height of the lower opening. This pocket is formed by extending the pulley stiles and weight boxes the full height, and covering them front and back with matched boarding, the yoke being cut in between the pulley stiles. Over the opening in the yoke a board, *S*, is fitted, which is pushed up by the sash and drops again as the sash is lowered. This board is called the "follower."

In the arrangement of the upper sash, the two details shown differ widely. In the window shown in Fig. 102 the upper sash is constructed like any transom sash, and the inside of the transom is finished by a shallow panel, the panel moulds being cut between the parting strips. If the lower sash is not more than 4 feet high, and the transom has but a 4-inch reveal, the transom sash may be stationary, as the glass can be cleaned by standing on the sill and reaching above the transom. If the lower opening is more than 4 feet high, or the transom has an 8-inch reveal, then the transom sash should be hinged so that it can be opened, the best way of doing this being to make the outside casing wider, as shown by the dotted lines, and the sash  $\frac{1}{2}$  an inch narrower, so that it will swing in by the parting strips, the sash being hinged at the bottom. In the drawing the transom sash is shown stationary. The author has used this construction with very satisfactory results.

The construction shown in Fig. 103 is very frequently used, and appears to be a very practical solution of the problem. This construction is the same as that of an ordinary double-hung window, with a head pocket, except that a transom is placed *in front* of the upper sash and the lower portion of the upper sash has a wood panel. By this arrangement both sashes slide up and down in the usual way, and the outside transom is merely for appearance, without the constructive functions of a transom.

The back of the stone transom is covered by a panel, with about  $\frac{1}{16}$  of an inch space between the panel and the outer sash. The only ob-

jections that the author can see to this construction is that ice might possibly form between the transom panel and the upper sash, and the difficulty of cleaning the glass in the upper sash, for when the sash is lowered so as to reach over it, the bottom of the glass would be behind the transom and inaccessible, although it might perhaps be reached from below. When the glass must be cleaned from the inside, the construction shown in Fig. 102, with the transom sash hung, would appear to be the most desirable. The dotted lines back of the transom show how a box transom may be built inside; it is very doubtful if this extra finish would add to the appearance, and it increases the difficulty of cleaning the glass.

Fig. 104 shows the elevation of a window similar to that shown at *E*,

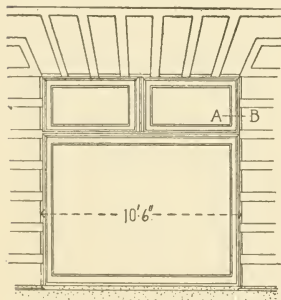

Fig. 104.

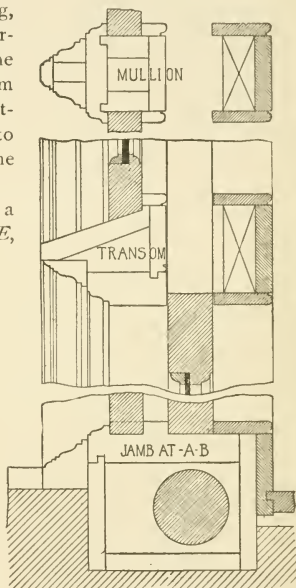

Fig. 105.

Fig 93, but with the upper lights divided by a wood mullion. This window is one of several used in the first story of the Odd Fellows' Temple, Philadelphia, Messrs. Hazlehurst & Huckel, architects. The lower light being very wide, gives a fine view from the inside and a good appearance from the outside. The construction of the window is shown in Fig. 105, the lower sash sliding up into a pocket above the head, and the transom sash being fixed. It will be seen that the general construction is very similar to that shown in Fig. 102, the

principal difference being that the transom is all of wood and the parts of the frame are heavier.

**96. Patent Double Hung Windows with Revolving Sash.**—Although the ordinary double hung window has been found superior, on the whole, to any other device for furnishing light and ventilation, it has two defects, one of which becomes quite serious in the upper stories of buildings. These defects are that the outside

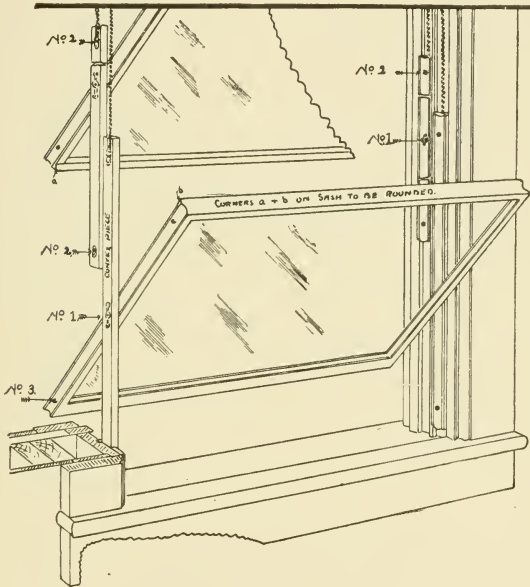

Fig. 106.—Bolles' Patent Revolving Sash.

of the glass is not easily cleaned, and only one-half of the opening can be utilized for ventilation at a time (unless there is a pocket above the head). Several devices have been patented for overcoming these objections, the most successful of which appears to the author to be those which permit each sash to revolve on a centre, thus permitting the outside of the glass to be easily cleaned from the inside, and also affording greater ventilation in warm weather.

**Bolles' Patent Revolving Sash.**—Of these patented windows, that which appears to have proved the most practicable, or which, at least, has found the greatest favor, is known as the Bolles' Patent Revolving Sash.

This window has been quite extensively used in New York and neighboring States with very satisfactory results.

The revolving arrangement can be fitted to any double hung window frame, as it affects only the sash. Each sash is pivoted at the centre of gravity of the sides, the sash being made narrower than the width between the stop beads and pivoted to a separate convex strip, which slides up and down in the frame, in precisely the same way as an ordinary window, the sash chain or cord being attached to the strips, as shown in Fig. 106. The inner surface of the strips is convex, and accurately fits into a corresponding concave groove in the sides of the sash, making a perfectly water-tight joint. The back of the sliding strips are pressed against the pulley stile by specially designed expansion pins, fitted with springs, and the pivots are also fitted with springs which hold the sash and sliding strips firmly against each other, no matter in what position the sash may be placed.

It is claimed that by means of the expansion pins, above described, the sashes are held as firmly and run as smoothly as in the old style window and are equally as tight. To turn either sash—reverse it, or place it in a slanting or horizontal position—all that is necessary is to push the bottom rail outward, the binding action of the springs being sufficient to hold the sash in any desired position. The sliding strips (preferably of straight grain white pine), may be made at the mill furnishing the sash, or can be procured from the Bolles' Revolving Co., who also furnish all of the necessary fittings and complete working plans for shaping the stiles and applying the fittings. The side pulleys should be placed as high as possible (overhead pulleys are preferred). The cord and weight are the same as in the ordinary window; parting strip to extend  $\frac{1}{8}$ -inch. This device is also used on transoms and large non-sliding sash. The mechanism of this sash and its operation is shown in Fig. 106.

**97. Heydebrand Safety Window.**—Another patented revolving window that has been used to a considerable extent, is the Heydebrand Safety Window. In this window the sash cord, chain or ribbon, instead of being attached directly to the sashes, is attached to a pivot, which is screwed to the centre of each sash. These pivots slide up and down in grooves in the pulley stile, carrying the sash



with them, as in an ordinary window. In the lower half of the window the parting strip is omitted, and the outside casing is kept back of the face of the pulley stile. The lower half of the inside stop head is hinged so that it can be swung in, thus permitting the lower sash to swing on its pivot. The

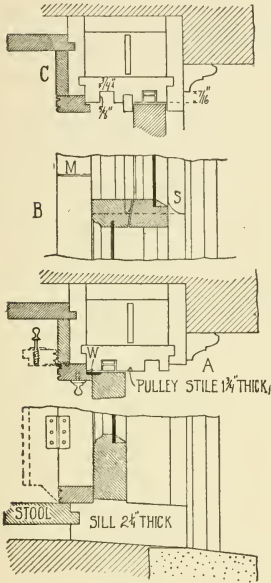

Fig. 107.

upper sash can also be drawn down opposite the lower sash and then revolved in the same way, or the lower sash may first be pushed to the top of the window, and the upper sash drawn down, and then reversed, but neither sash can be revolved in the upper part of the frame. The action of the sashes requires a specially constructed frame, the details of which are shown in Fig. 107.

The pulley stile is made  $1\frac{1}{4}$  inches thick, with a groove for the parting strip extending to the centre of the meeting rails, and  $\frac{3}{8} \times \frac{3}{4}$ -inch grooves for the pivots extending to within 1 inch of the sill. At the proper height a bearing is inserted in the pivot grooves for the pivots to turn on.

The stop bead is double rabbeted and is cut in two at *M* (detail *B*), the lower portion being hinged to swing in, as shown by dotted lines in detail *A*.

### 98. Casement Frames.—Win-

dows in which the sash are hinged at the sides, to swing in or out like a door, are called *casement* windows. When the windows are 6 or 7 feet high and the sash are divided into two folds, the sill coming nearly to the floor, they are frequently termed *French* windows.

It is very difficult, and in fact almost impossible, to construct a casement window so that the rain cannot beat in, unless the sash are hung to swing out; and if the sash open outward it is impracticable to use outside fly screens. If the window is in an exposed position it will be much better to have the sash swing out, even if it does necessitate inside screens.

The construction of a casement window frame is very much like

that of a door frame, the difference being in the arrangement of the wood sill and in the rebate for the sash.

Fig. 108 represents a section through the jamb, sill and meeting stiles of a casement window in which the sash are to swing out, showing the English method of forming the rebates. In ordinary work in this country, the half-round rebate, *B*, is generally omitted, and also the astragal mould at *A*, the meeting stiles having an ordinary rebate. Fig. 110 shows a style of casement frame often used in the

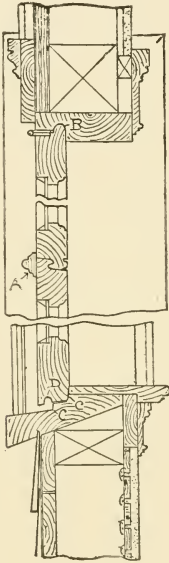

Fig. 108.

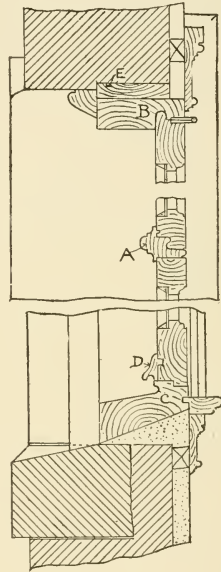

Fig. 109.

East. The rebate for the bottom of the sash is the same as in the previous example, but the side rebates are different. The hollow in the edge of the stop bead is made with the idea that if rain is driven through the rebates it will stop in this space and descend to the sill, where an outlet should be provided for it. It should be noticed that with a frame of this pattern the sash can only open a little more than  $90^\circ$ . If it is desired to swing the sash back against the wall, the edge of the frame must be kept out nearly to the face of the wall. The

strip of board shown on the back inside edge of the frame is nailed to the frame for the purpose of holding it more securely in place, and may be in short lengths. The shape of the staff bead is purely a matter of design; often it is "stuck" on the frame, but there are some advantages in making it in a separate piece, as shown in the figure. The dotted lines across the transom bar show how it may be built of two pieces of plank.

Figs. 109 and 111 show two details for casement frames with the sash opening in. The former is the English method, and is generally considered the best, although the sill detail shown in Fig. 111 is an excellent one; this joint is designed on the idea that if water penetrates to the groove, *G*, the force will be diminished by the increased

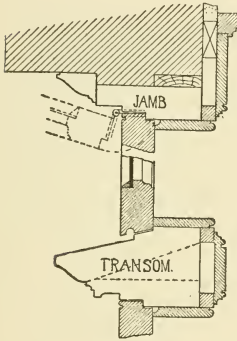

Fig. 110.

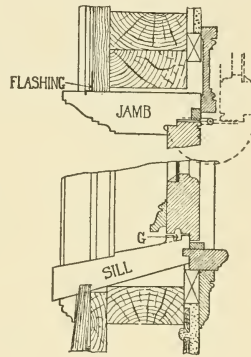

Fig. 111.

area of the space, so that the water will collect in the bottom of the groove and pass out through little holes bored through the outer lip.

The outside finish of the frame shown in Fig. 111 is merely offered as a suggestion, and is not an essential part of the construction, the most important constructive features of these two details being the connections with the jambs and sill. Casement window frames and sash should always be at least  $1\frac{3}{4}$  inches thick, and when in a brick or stone wall should be well secured to the masonry.

When casement windows are less than 5 feet high, and more than 3 feet wide, it is better construction to have a narrow mullion between the sash than to have the sash rebated together.

**99. Pivoted Windows.**—*A. Pivoted at the Sides.*—In many places where windows with a single sash are used, it will be found

better and more economical to pivot them at the centre of the sides than to hang them on hinges. In audience rooms, especially, this is a very good arrangement for small windows, and even sash 8 and 10 feet high are often pivoted in this way. By swinging the sash out at the bottom, and in at the top, the danger from leakage is not much greater than in a double-hung window. The frames for such windows should always be made of plank; they should not be rebated, but made as shown in Fig. 112, with stops, *S S*, nailed partly to the frame and partly to the sash, as shown. Both stops are cut on a bevel near the centre of the window, the upper part of the outside stops being nailed to the frame and the lower part to the sash, while the reverse is the case with the inner stop. The sill joint should be as shown in Fig. 108.

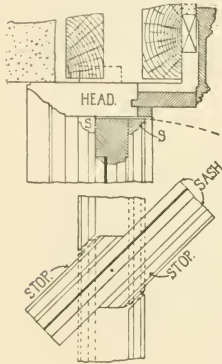

Fig. 112.

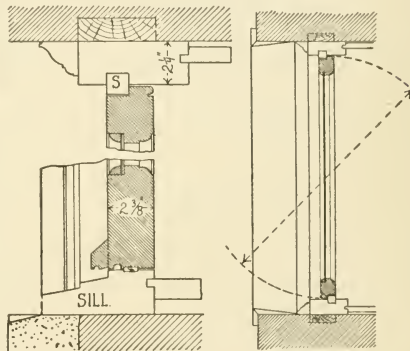

Fig. 113.

*B. Windows Pivoted Top and Bottom.*—Large plate glass windows, when of a single light, are generally pivoted at the top and bottom, and when the sash is of an unsymmetrical shape, as in the case of the outer sash in the window shown at I, Fig. 93, this is about the only practical way of opening the window.

The frames for such windows should be made of plank, and the joint between the bottom rail of the sash and the wood sill should be arranged in a similar manner to that shown for casement sash which open inward.

Fig. 113 shows the detail of the large single light windows in the Odd Fellows' Temple, Philadelphia, and the manner of stopping the

sash at the sides appears to the author to be about as good as can be devised. The stop, *S*, is placed flush with the outside of the sash at one side of the window, and flush with the inside of the sash at the other side, as shown in the plan. Such windows are also constructed in a manner similar to that shown in Fig. 112, with one stop nailed to the inside of the sash and the other to the outside, and the upper stops cut at the centre. Windows up to 5 or 6 feet wide may be pivoted in this way, but the sash should be made quite heavy, and never less than  $2\frac{1}{4}$  inches thick.

**100. Bay Windows.**—As bay windows are commonly constructed there is a solid pier at the angles, and the windows proper are made the same as if in a straight wall. When the bay is of masonry, and it is desired to have the angle between the windows as small as possible,

iron or stone angles or mullions are used. Very frequently an iron post is set into the angle to support the lintels above, and is cased with stone or terra cotta on the outside. Fig. 114 shows a section through an angle constructed in this way, which may be of value to the younger architects in showing the manner of securing the frames and the terra cotta casing.

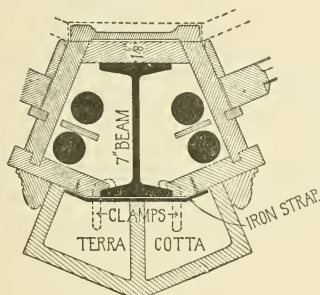

Fig. 114.

*Shallow Bay Windows* are also often built within the thickness of the wall in brick or stone

buildings, and in such cases the whole bay is formed by the window proper. Fig. 115 shows a half elevation and plan of two styles of such windows. In the one at the left casement sash are employed, and in the one at the right the side window is double hung, while the centre sash is stationary, or it can be pivoted top and bottom. Enlarged sections, on the lines *A*, *B*, *C*, etc., are shown in Fig. 116. The aim in such windows is to make the woodwork as light as is practicable, and hence the pockets for weights are dispensed with in the double-hung window and sash balances used instead of weights, although by making the angle about 3 inches wider pockets could be obtained.

The lead strip shown in Section *E* is a good suggestion for protecting the joint under the wood sill of any window from the weather,

and, although not often used, would be desirable in all first-class residences. The inside finish of the head and sill would be essentially the same in both of the windows shown.

When such windows extend through two stories the wall under the

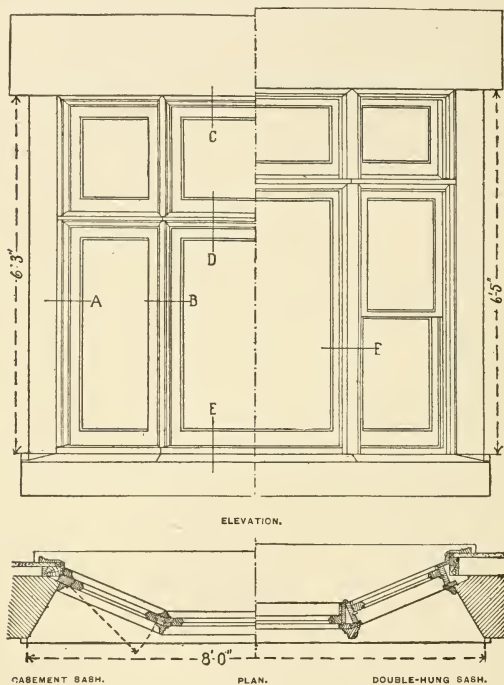

Fig. 115.

upper windows need not be more than 6 inches thick, thus increasing the size of the room.

Stone lintels over such windows should either be of the full thickness of the wall or should be supported by an iron lintel, with a wide plate at the bottom flush with the stone.

**101. Sash.**—The movable frames which receive the glass in any style of window are called "sash," and are made in essentially the

same manner throughout the country, and for various kinds of windows. Fig. 117 shows an elevation of the sash for a double-hung window and enlarged sections through the rails.

The pieces forming the top and bottom of the sashes are called "rails," and the side pieces are the "stiles." The small bars dividing the sash into lights are usually called "muntins," although sometimes called sash bars. The latter term, however, is more frequently applied to the bars which divide the large windows used in store fronts. The different pieces of glass are commonly called lights, and a window is spoken of as one-light, two-light, four-light, etc., accord-

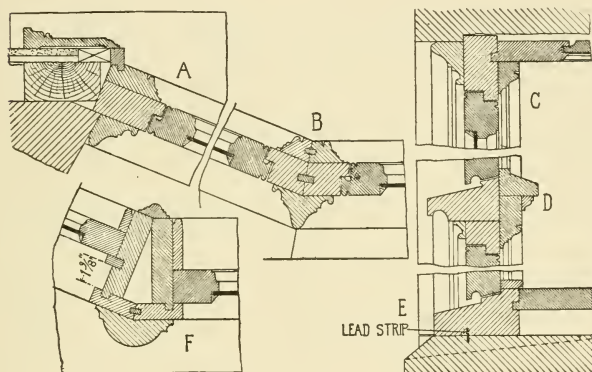

Fig. 116.—Detail of Bay Windows.

ing to the number of "panes" of glass in the *whole* window. Formerly windows of ordinary size were made with as many as eight and twelve lights, owing to the greater cost of large pieces of glass, but now such windows are generally made with only one light in each sash, which is called a "two-light window" when double hung. The sash in factory windows, etc., are still made with eight, twelve or eighteen lights, and small lights are sometimes used in dwellings for architectural effect. Glass is now so cheap, however, and it is so much easier to clean windows having but one light to each sash, that the large lights are generally preferred.

As a rule, the size of a window is indicated by the size of the glass and the number of lights. Nearly all lumber dealers carry several sizes of sash in stock, already glazed, and such sashes are called

"stock sash." They cost a little less than custom-made sash, and are generally used in the cheaper class of buildings.

The common thicknesses of sash are  $1\frac{3}{8}$ -inch and  $1\frac{1}{4}$  inch, but the former should only be used in the cheapest class of buildings. The usual proportions of the rails and stiles in such sash are given in Fig. 117. In New England the width  $A$  is generally only  $1\frac{3}{4}$  inches and the width  $C$  only  $2\frac{1}{4}$  inches, but in the Middle and Western States the dimensions given are almost universal.

In stock windows and in custom-made windows, unless otherwise indicated, the width,  $B$ , of the meeting rail is made 1 inch. In wide

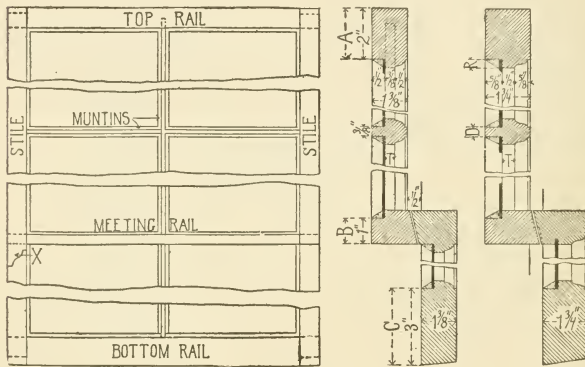

Fig. 117.—Sash Details.

windows these rails are quite sure to spring, and should therefore either be made heavier or made of oak. The stiles are always made of the same section as the top rail.

Two details are shown for the meeting rail of the lower sash. Both appear to be commonly used, even in stock sash. In the  $1\frac{3}{8}$ -inch sash the lower meeting rail is shown rebated for the glass, and in the  $1\frac{1}{4}$ -inch sash it is grooved to receive the glass. The former section contains the more wood, and hence is the stiffer of the two, but of course it offers greater obstruction to the vision. Occasionally the joint between the meeting rails is lapped, as shown by the dotted lines on the section of the  $1\frac{3}{4}$ -inch sash, but this is not as desirable a joint as the straight bevel.

In all kinds of sash the rails are mortised and tenoned into the



stiles, and the thickness of the tenon is usually the width of the fillet *T*, shown in the sections. In thicker sash than those shown it should be about one-third of the thickness of the sash. The shape of the moulding on the inside of the sash may be varied to suit the individual taste, but should be of a shape that will permit of "coping" to advantage at the joints, the mouldings shown being about the best in this respect.

The weakest portion of a double-hung sash is the meeting rails and where they are tenoned to the stiles, and it is not infrequent that the tenon is pulled out of the mortise in raising or closing the window. To avoid this the stiles are sometimes extended below and above the meeting rails, as shown at *X* in the elevation drawing. This permits of making a strong joint, and is to be recommended for offices, tenements, etc. Such an extension, of course, prevents the sash from being raised or lowered its entire height, but in large windows this is of no great consequence.

Sash for plate or leaded glass should never be less than  $1\frac{3}{4}$  inch thick, and  $2\frac{1}{4}$  inches is to be preferred. For very large windows  $2\frac{3}{4}$ -inch sash are sometimes used.

Single and double-strength glass is generally secured by tin "points" and putty. Plate glass is generally secured by a wood strip, as shown in Fig. 105.

Wooden sash should be made from the best quality of white pine, cypress or redwood, clear, straight-grained white pine being generally preferred. Hard wood sash are sometimes used, but they are more likely to warp than pine sash, and where a hard wood finish is desired it is best to veneer a pine sash.

**102. Store Window Sash.**—Store windows only 5 or 6 feet wide between posts or piers usually have the glass set in a stationary sash, which is made in essentially the same way as smaller sash, and either  $1\frac{3}{4}$  or  $2\frac{1}{4}$  inches thick. If double-strength glass is used the sash is generally divided into large lights by wood muntins about  $\frac{3}{4}$  inch or 1 inch wide between the glass.

When plate glass is used the lower light is generally the full width of the sash and from 6 to 7 feet high, with a wood muntin or transom bar across the top, or if the light above is also of plate glass, and it is desired to give the appearance of a one-light window, an iron muntin, or sash bar, of the section shown at *C*, Fig. 118, and covered with thin nickel-plated brass over wood, is placed between the lights. Such small bars are only suitable for lights not over 6 feet wide.

In the principal retail stores of large cities it has become the custom to make the entire front of the store one large window, with lights of

plate glass from 6 to 10 feet wide and 7 or 8 feet high, with other lights about 3 or 4 feet high above them. In such store fronts framed sash are not used, but small posts or sash bars are set up between the lights, extending from the sill to the top of the window, and other similar bars are cut between them at the height of the lower light, thus making a framework to hold the glass.

As the desire of the ordinary merchant is to have as much plate glass as possible, the columns which support the wall above are usually set 4 or more inches inside of the wall line, and the plate glass not more than  $1\frac{1}{2}$  inches inside of the line, and sometimes flush with it,

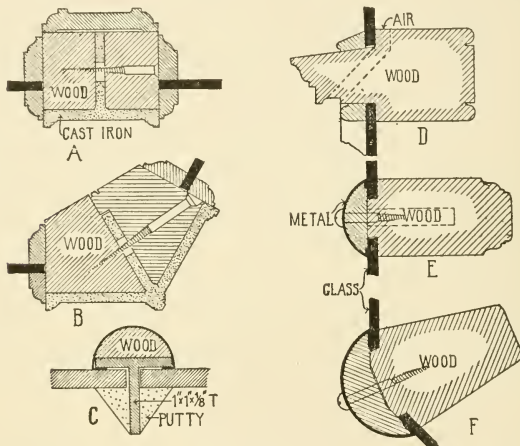

Fig. 118.—Sash Bars.

so that the window may be placed in front of the column and extend unbroken, except by the entrances, from corner to corner.

It is also the fashion to make the bars which separate the lights of glass of the least size which will give sufficient strength to hold the glass and prevent the window from being blown in. In the better class of stores the outside of the sash bars is usually covered with ornamental metal, and quite often iron bars are placed between the wood to give the necessary strength and to prevent warping.

Fig. 118 shows types of sash bars in most common use in large windows, although they may be varied in size and in the detail of the mouldings. Sections *A*, *B*, *D*, *E* and *F* are drawn to one-fourth of the usual size.

Sections *A* and *B* are quite common in Chicago. The strength of the bar is afforded by a cast iron T, of which only the front is exposed. The front is generally copper plated and oxidized, and often ornamented by relief work. The T is filled out to a square by pieces of thoroughly seasoned wood, screwed or bolted together as shown. Wooden stops are then screwed to the wood core to hold the glass, or iron stops may be used if preferred, but hard wood is probably better. The usual size of sash bars of this pattern appears to be 3 inches wide and  $2\frac{1}{2}$  inches deep, exclusive of the inside casing and stops, but they can be reduced to  $2\frac{1}{2}$  inches wide and made 3 inches deep. The section at *B* is for an angle in the window. When the angle is a right angle the cast web may be omitted and the facing screwed to a solid piece of wood.

Sections *E* and *F* are quite extensively used in all large cities, and as a rule will be found cheaper than the cast iron bars. In these bars the whole construction is of wood, which should be of the best quality of white pine or cypress, the glass being held by a half-round strip screwed to the bar. The half-round is covered on the outside with thin brass or copper, which may be nickel plated or oxidized, the metal extending over the edge about  $\frac{1}{4}$  inch to hold it in place. Such bars have the appearance of being of solid metal. They are carried in stock in sizes of 2,  $2\frac{1}{2}$  and 3 inches, or can be made to order. They can also be adapted to any angle in the manner shown at *F*.

The wooden bar forming the support is, of course, made by the carpenter, and should be about  $2 \times 3\frac{3}{4}$  inches. It may be plain or moulded, as desired.

Sometimes a wrought iron bar about  $\frac{3}{8} \times 3$  inches is placed in the centre of the wood bar, corresponding to the web of the T, detail *A*, and the metal-covered bar is screwed into the edge of the iron bar, as shown by the dotted lines. This adds much to the expense and does not appear to be necessary if the wooden bars are made of the size above indicated.

The cross bars are generally made of the same section as the upright bars, although it is not necessary to do so.

The detail at *D* shows a wooden transom bar which has been used in connection with the upright bar *E* with very good effect.

Whatever may be the shape of the bars, the upright bars should always extend from sill to head in one length, and the horizontal bars should be cut between them.

With bars of the shape shown at *D*, *E* and *F*, it is of course necessary to set the glass from the outside, and it is generally considered

best that all glass should be set from the outside, although where fixed sash are used in store fronts the glass is often, for convenience, set from the inside.

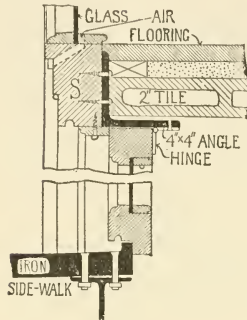

Fig. 119.

Fig. 119 shows a section through the sill and "bulkhead" of a store window, where the bulkhead is of fireproof construction. If the rest of the store front is faced with iron, the front of the sill may also be treated in the same way, the facing being screwed to the wood,

Considerable difficulty is often experienced with store windows in preventing their becoming covered with frost in cold weather. For this reason small inlets for air are often provided in the sill and transom, as shown in Fig. 119 and at *D*, Fig. 118, to afford ventila-

tion and to permit of the escape of moisture that may gather on the inside of the glass.

#### WINDOW GLASS AND GLAZING.

**103. Glazing.**—The glazing of windows originally belonged to the painters' trade, and when glass has been broken it is still customary to go to a painter to get it replaced, but when new windows are to be glazed it is so much more convenient to glaze them at the mill or factory where the sash are made that this has now, the author believes, become the universal custom, and hence the glass and glazing is usually included in the carpenter's specifications.

Common window glass is almost always set with putty and secured with triangular pieces of zinc called glaziers' points, driven into the wood over the glass and covered by the putty. In the best work a thin layer of putty is first put in the rebate of the sash, the glass placed on it and pushed down to a solid bearing. This is called "back puttying." The points are then driven about 8 or 10 inches apart, and the putty applied over the glass and points so as to fill the rebate. Outside windows should always be glazed on the outside of the sash. Plate glass should be back puttied and secured by wooden beads, and also all door lights.

*Leaded glass* is generally furnished and set by parties that make a business of ornamental or "stained" glass. It is quite common for the architect to fix a certain sum of money, in the specifications, to be allowed by the carpenter for the leaded glass, and to be expended under the direction of the architect, although where clear glass is used it is just as well to show the pattern on the drawings and specify it in the same manner as any other work. If colored glass is to be used, however, it is best to make a definite allowance and then entrust the work to a good art glass worker.

**Sheet Glass.**—Common window glass is technically known as sheet or cylinder glass. "It is made by the workmen dipping a tube with an enlarged end in the molten glass or 'metal' until from 7 to 10 pounds are gathered up. Then it is blown out slightly, taken on a blowing tube and still further manipulated, until a cylinder about 15 inches in diameter and 45 inches long is formed. This cylinder has the two ends trimmed off, is then cut longitudinally and gradually warmed, when it is placed on a large flat stone supported by a carriage, where it is heated until it softens sufficiently to open out flat; the carriage is then pushed into the annealing chamber and the sheet taken off."

*Grades and Qualities of Sheet Glass.*—Sheet glass is graded as double or single strength, French, German or American make, and as first, second or third quality, the strength and quality always affecting the price.

Previous to about the year 1875 nearly all of the window glass used in this country was imported from France or Germany, but since then American glass has been gradually taking the place of imported glass, until at the present time little, if any, imported sheet glass is used, except in the portions of the country bordering on the Atlantic. In Boston, German glass is used entirely when first-quality glass is furnished, as only the second and third qualities of American glass are carried in that market (with the exception of special brands, such as Chambers' "Eagle Brand"). The German glass, so called, sold in the Eastern markets is really made in Belgium, but is still sold under the old name. There is now no true French or German sheet glass carried in this country, and when either are specified Belgium or American glass is furnished.

The Belgium glass is generally considered as superior to the American glass, but it is very doubtful if there is any practical difference between the two in the better grades. Since the adoption of the new

tariff the price of German glass in the Eastern cities is about the same as that of American glass.

All common sheet glass, without regard to quality, is graded according to thickness, as "single strength" or "double strength." The double-strength glass is supposed to have a nearly uniform thickness of  $\frac{1}{8}$  inch, while the single-strength may be as thin as  $\frac{1}{16}$  inch. The thickness of single-strength glass, however, is generally far from uniform.

All lights over 24 inches wide should be double strength, and in the better class of buildings it is best not to use single-strength glass at all.

Both single and double-strength glass are sorted into three grades or qualities, the classification depending upon color, brilliancy and flaws.

In the common American glass the best quality is designated as AA, the second as A and the third as B. The AA quality is supposed to be as good glass as can be made by the cylinder process. As even this glass, however, is not entirely free from defects, it is very difficult for any one but an expert to tell exactly whether certain lights of glass are first or second quality. The second and third qualities are only suitable for cellar windows, stables, factories, conservatories, etc. For residences, schools, apartment buildings, etc., nothing poorer than first quality should be specified.

*Sizes.*—The regular stock sizes vary by inches from 6 to 16 inches, and above that by even inches up to 60 inches in width and 70 inches in height for double strength and 30x50 inches for single strength.

*Cost.*—The prices for sheet glass, as for all other clear glass, varies with the size, strength and quality. It is determined by a schedule, or price list, fixed from time to time by the glass companies, from which a very large discount is made, fluctuations in prices being regulated by the discount, the list generally remaining unchanged for a number of years. The only way of ascertaining the price of a light of glass of a given size is by means of the price list and discount.

The price per square foot increases rapidly as the size of the glass increases, so that it is much cheaper to divide a large window into eight or twelve lights than into two lights. Compared with the cost of the building, however, the glass is a small item, and in the better class of buildings each sash is usually glazed with a single light of glass. In factories, workshops, etc., where there is usually a great amount of glass surface, the size of the lights is not of so much importance, while the saving by using small lights is quite an item;

hence twelve and even sixteen-light windows are generally used in such buildings.

The following table shows quite clearly the relative cost per square foot for different sizes of American glass, the prices given being about an average for the whole country at the present time (1897):

COMPARATIVE COST PER SQUARE FOOT OF AMERICAN SHEET GLASS.

GRADE.	SIZE OF LIGHT IN INCHES.						
	10x12	15x20	24x34	30x36	36x40	40x60	60x70
	PRICE IN CENTS.						
Double strength:							
First quality.....	7.6	8.6	12.8	15.8	15.8	20.4	43
Second quality.....	6.8	7.8	11.6	14.4	14.4	18.4	41.8
Single strength:							
First quality.....	5.6	6.4	9.6	12			
Second quality.....	5.2	5.8	8.4	10.8			

From this table it can be seen that to glaze a given area with 10x12-inch lights will cost only one-half what it would with 30x36-inch lights, and only about one-third the cost of 40x60-inch lights. Two lights 30x70 inches cost but little more than half as much as one light 60x70 inches. Two lights of glass of the same area but different dimensions, however, will cost practically the same.

The comparative cost of German and American sheet glass is indicated by the table in Section 104.

**Special Brands of Sheet Glass.**—There are a few American firms that make a better quality of sheet glass than that which is ordinarily found in the market, and they designate their product by special trade marks.

One of these special brands of common window glass is "Chambers' Eagle Brand," which is made in three qualities, designated as "Three Star," "Two Star" and "Star," and in both single and double strength. The Three Star, double strength, is claimed to be superior to the ordinary AA glass, and it has this advantage, which most architects will appreciate, that each sheet bears a label showing the brand and quality. This enables the architect to be sure that he is getting the kind of glass specified. The cost of this glass is practically the same as that of ordinary American glass of corresponding grade.

The Chambers Glass Co. also make a special grade of window glass known as "Chambers' Eagle Brand" 26-ounce crystal sheet glass.

This glass is made by the cylinder process, but under improved methods ; it is a little thicker than the double-strength glass and of greater brilliancy and transparency. This is probably the best glass made, next to plate glass, and either it or plate glass should be specified for all first-class residences, hotels, office buildings, etc. For ordinary sizes it costs about 90 per cent. more than first quality double strength and about one-half as much as plate glass. It is made in regular sizes up to 48x52 inches, and each sheet is labeled with the trade mark. There are also other brands of "crystal sheet" glass, which are of about the same quality.

*Defects of Sheet Glass.*—All sheet glass, when looked upon from the outside, has a wavy, watery appearance, like the surface of a lake slightly agitated by the wind, and when the sunshine falls upon it the irregularity of the surface is greatly emphasized. This characteristic of sheet glass is due to its being made in the shape of a cylinder and then stretched or flattened out into a sheet, and cannot be wholly avoided. Besides this universal defect, the cheaper grades are often stringy or blistered, or sulphured, or smoked, or stained, so that, in looking through the glass, objects seen at a distance are deformed and distorted.

**104. Plate Glass.**—For lights of glass over 60x70 inches in size it is necessary to use plate glass, and owing to the watery and uneven appearance of cylinder glass, plate glass, which is perfectly clear and transparent, is becoming more largely used every year for windows of ordinary size, especially in fine residences, hotels and office buildings.

The process of manufacture of plate glass is entirely different from that of sheet glass. In making plate glass the metal, which is prepared with great care, is melted in large pots and then cast on a perfectly flat cast iron table. "The width and thickness of the plate is determined by means of metal strips called 'guns,' which are fastened on, and on which a heavy metal roller travels. The ends of the guns are tapered, so that when the roller is at one extremity it and the guns form three sides of a shallow rectangular dish. The molten metal is poured on and the roller passed along slowly, forcing the metal in front of it and rolling out the sheet."

The sheet is then annealed, and forms what is known as "rough plate," which is used for vault lights, skylights, floor lights and the like.

"For polished plate the rough plate is carefully examined for flaws, which are cut out, leaving the largest size sheet practicable ; then



the plate is fastened to a revolving stone by means of plaster of Paris, and two heavy shoes, shod with cast iron, are mounted over it. The stone is then revolved and sand and water fed on to the surface; the shoes revolve also, going over all parts of the plate and grinding it down to a true plane. Then emery powder is fed on in successive degrees of fineness until the plate is made absolutely smooth and all grit removed. Then new rubbers, shod with very fine felt, are put on and liquid rouge is added for the polishing. When one side is completed the other side is similarly treated, the plate losing about 40 per cent. in weight by the operation."

*Qualities of Polished Plate Glass.*—There are practically but three qualities of polished plate glass now on the American market, viz.: French plate and two grades of American plate—first, silvering quality, which is used for mirrors exclusively, and second, glazing quality.

French plate is now only used in this country for mirrors, for which purpose it is generally considered superior to the American glass, although the silvering quality American glass is rapidly supplanting the French glass; and the manufacturers claim it to be equal to the latter in every respect.

French plate may be distinguished from American plate by the color when looked at endways, the French glass showing perfectly clear and white, while the American glass has a decidedly bluish color. American glass is said to resist the weather better than the French glass.

The usual thickness of American polished plate glass is  $\frac{1}{4}$  inch, but there is also made a thinner plate, commonly known as  $\frac{3}{16}$ -inch plate, which is just like the regular glazing plate, except that it is thinner. It is ground from the same thickness of rough plate as regular plate glass. It is used principally in thin sash, such as are used in railway coaches, and where the saving in weight is a consideration.

American glazing plate glass is made in but one quality, the only variation being in the thickness.

*Cost.*—The cost of plate glass varies with the size of the lights, but not so great an extent as with sheet glass. At the present time the net price of American polished plate, glazing quality, is about 48 cents per square foot up to 10 square feet; 66 cents from 10 to 40 square feet, and 80 cents for sheets containing 120 square feet. For larger sheets the price increases rapidly up to \$2.50 per square foot for the largest size.

The price, however, can only be accurately determined by means of the official price list and the discount, which at present varies from

75 to 80 per cent., according to locality. Three-sixteenths-inch plate costs from 10 to 15 per cent. more than the regular plate, because of the extra expense in grinding it down. French plate costs about 50 per cent. more than the American plate.

*Sizes.*—Glazing plate is made in stock sizes varying by even numbers from 6x6 inches up to 144x200 inches, or 138x208 inches.

**Comparative Cost of Different Kinds of Window Glass.\***—The following table gives as close an idea of the comparative cost of the different kinds and qualities of glass used in this country for glazing as it is possible to arrive at, the prices for the sizes given being the present net average price :

KIND OF GLASS.	SIZE OF LIGHT IN INCHES.			
	24x32	30x36	36x40	48x60
<i>American Plate.</i>				
Glazing quality .....	\$2.56	\$3.60	\$4.80	\$13.00
26-ounce crystal sheet.....	1.20	1.96	3.00	12.50
<i>German (Belgium) Sheet.</i>				
Double strength, 1st quality.....	.68	1.04	1.57	5.89
Single strength, 1st quality.....	.50	.77	1.17	
<i>American Sheet.</i>				
Double strength, 1st quality.....	.64	.99	1.58	6.67
“ “ 2d quality.....	.58	.89	1.44	6.31
Single strength, 1st quality.....	.48	.73		
“ “ 2d quality.....	.40	.67		

It will be seen from this table that the relative difference in the cost of plate and sheet glass decreases rapidly as the size of the light increases.

**105. Stock Windows.**—Nearly all lumber dealers carry in stock certain sizes of sash, which are commonly known as “stock sash ;” the two sash for a double-hung window form a “stock window.” As these stock sash or windows are made in great quantities, they can be made and sold cheaper than custom-made sash (sash made to order), and hence are extensively used in the construction of the cheaper class of buildings, and especially in the smaller cities and towns. The fact that they can be obtained at any time without delay also operates frequently to the selection of stock windows.

Stock sash are not usually as well made as custom-made sash should be, nor are they usually glazed with the best quality of glass,

\* The prices in this table are based on a discount of 80 per cent. for plate glass, 60 per cent. for American sheet glass and 50 per cent. for 26-ounce crystal sheet.

and for these reasons they should not be used in first-class buildings. For many buildings, however, they may be used with reasonable satisfaction, and with a considerable saving in the cost of the building, so that it is well for the average architect to know about them.

The sizes and details of stock windows vary in different localities, and if the architect has occasion to use them he should obtain a catalogue from a lumber dealer, giving the stock sizes carried in that locality.

As a rule, double-hung windows may be obtained with two, four, eight and twelve lights to the window, and in two thicknesses of sash. Two-light windows are generally made for glass sizes from 16x24 inches to 30x40 inches; four-light windows, from 10x20 inches to 15x32 inches; eight-light windows, from 9x12 inches to 14x24 inches, and twelve-light windows, from 8x10 inches to 12x24 inches.

The nominal thickness of stock sash varies in different localities. In the Western and Northwestern States the stock thicknesses are  $1\frac{3}{8}$  inch and  $1\frac{1}{4}$  inch, although not all dealers carry the  $1\frac{3}{8}$ -inch thickness. In Pennsylvania stock sash are made in  $1\frac{1}{4}$  and  $1\frac{1}{2}$ -inch thicknesses, and in Boston four and twelve-light windows are made in  $1\frac{1}{4}$ ,  $1\frac{3}{8}$  and  $1\frac{1}{2}$ -inch thicknesses, while the two-light and eight-light windows are made only in one thickness,  $1\frac{1}{2}$  inch. The Western sash generally run about  $\frac{1}{16}$  inch scant. Almost all stock windows are made for  $\frac{3}{8}$ -inch parting strips.

Besides the sash for double-hung windows, single sash for cellar windows and skylight and hot-bed sashes are also generally carried in stock.

Cellar sash are usually made in one, two and three lights, the size of the glass generally varying from 7x9 inches to 12x18 inches. These sash are generally made only in one thickness,  $1\frac{1}{4}$  inch.

Stock sash are almost invariably sold already glazed, and, as a rule, both single and double-strength windows are carried in stock, but with only one quality of glass. In specifying or ordering stock sash, therefore, it is necessary to specify the number of lights to the window, the size of the lights, the thickness of the sash, and whether single or double-strength glass is wanted.

In the Middle and Western States two-light stock windows are 4 inches wider and 6 inches higher than the width and combined height of the glass, with a slight increase in the width for four, eight and twelve lights. In New England all stock sash are made  $3\frac{1}{8}$  inches wider and 5 inches higher than the glass.

**106. Outside Door Frames.**—The frames for all outside doors, whether in wooden or brick walls, should be made out of plank not less than  $1\frac{3}{4}$  inches thick and rebated on the inner edge for the door. In wooden walls the outside of the frame is finished with casings corresponding with those on the windows. In brick or stone walls a staff bead or brick mould is generally nailed to the outer edge of the frame, but sometimes the frame itself is moulded and the staff bead dispensed with.

Where the doors open inward the inner edge of the frame should be set flush with the plaster. In dwellings provision should always be made for hanging a screen door on the outside of the frame.

Fig. 120 shows the usual construction of the outside door frames in wooden buildings. If the screen door is to be hung to the outside

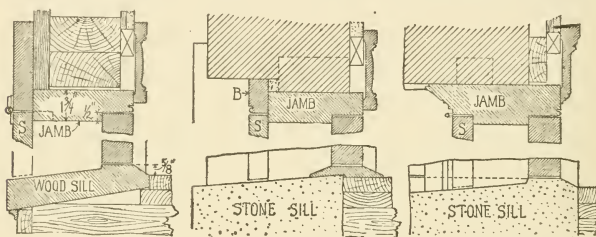

Fig. 120.

Fig. 121.

Fig. 122.

casing the latter should be  $1\frac{1}{8}$  inch thick. Sometimes the outer edge of the frame is rebated for the screen door, as shown by the dotted lines, and when the frame has a transom bar this method of hanging the door is the better of the two, and in all cases it has a neater appearance.

The shape of the sill shown in Fig. 120 is undoubtedly the best, but very often a plain plank is used and a narrow threshold placed under the door, as shown in Fig. 121.

Fig. 121 shows the usual method of making the outside door frames for common brick buildings in the West. The jambs and head are usually made out of 6-inch plank, with a  $1\frac{1}{8}$ -inch brick mould (*B*), to which the screen door is hung. If the brick mould or staff bead is of different shape the screen door should set in a rebate in the outer edge of the frame.

The dotted lines back of the jamb indicate short pieces of 2x4 studding nailed to the frame to hold it in place.

In dwellings a plain stone sill with a wooden threshold is generally used.

Fig. 122 shows a moulded jamb quite common in certain portions of the country. It is the opinion of the author, however, that a separate staff bead is better, as well as a little less expensive. There is no particular advantage in making the frame more than  $5\frac{3}{4}$  inches wide (not including the moulding) other than that a wide frame is generally held more securely in the wall. In public buildings, and sometimes in residences, the stone sill is cut to the shape shown in Fig. 122, and no wood threshold is used. This is a much better arrangement than that shown in Fig. 121, as the wood threshold often curls up, permitting the water to be driven under it, and of course the wood is not as durable as the stone.

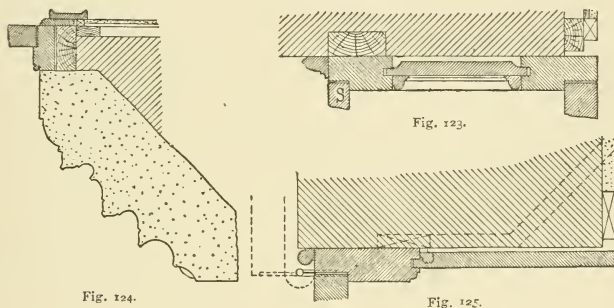

Stone sills of the shape shown in Fig. 122 are frequently termed "thresholds." The top of the threshold, whether of wood or stone, should be from  $\frac{5}{8}$  to  $\frac{3}{4}$  inch above the finished floor to permit the door to clear a carpet or rug on the inside.

In brick or stone dwellings having outer walls 12 inches thick or over it is quite common to make the door frame with paneled jambs and head, as shown in Fig. 123. In stone buildings the wide frame saves something in the width of the stone reveal, and in both stone and brick buildings permits of the use of a thinner lintel over the opening. The stiles of the panels should be made  $1\frac{3}{4}$  inch thick, as in solid frames.

In public buildings, especially where the reveals are of stone, the door frames are often made only  $5\frac{1}{2}$  inches wide and set nearly flush with the stonework, as shown in Fig. 124. By this method the wall

opening is made of practically the same width as the doors, and the apparent depth of the reveal, or thickness of the wall, is greatly increased. In such buildings screen doors are not generally used. If the doors are to swing outward, as should be the case in all public buildings, the door frame should be set nearly flush with the outside face of the wall, as shown in Fig. 125, so that the door may swing back against the face of the wall, unless there is a very deep reveal, in which case a narrow jamb, rebated on the outside, may be set on the inside of the wall, and the door can swing against the reveal.

If the frame is set as in Fig. 125 it may be finished on the inside either by a plain board or panel, or the jamb may be plastered out to the frame, as is often done in churches. If the jamb is plastered a  $\frac{3}{4}$ -inch strip of pine should be nailed to the back of the frame to form a ground for the plastering, and to receive a small moulding placed in the angle formed by the frame and plaster. The dotted lines in Fig. 125 show the manner of finishing the jamb with plaster.

Transom bars over doors are generally made of solid plank, housed into the jambs about  $\frac{1}{2}$  inch and rebated for the door on the under side, the upper side being made as for a window sill. The outer edge of the transom bar in dwellings should project sufficiently to catch the screen door, but should not cut into the staff bead.

The material for outside door frames should be clear, well-seasoned white pine, redwood or cypress. If a hard wood finish is desired  $\frac{1}{2}$ -inch veneers over a pine core should be used. Outside veneered frames, however, do not stand well unless there is a deep reveal or the doorway is protected by a porch.

**107. Securing the Frames to the Wall.**—It is important that the door frame in a brick or stone wall be well secured to the masonry, otherwise the swinging and slamming of the door will soon loosen the frame from the wall. The most common method of securing the frame is to spike it to wooden blocks of the size of a brick, built into the wall. This does very well when the work is new, but after the wood bricks have seasoned and shrunk the frame often works loose.

A better method is to spike blocks of wood to the back of the frame, if the frame is built in place, as shown by the dotted lines in Figs. 121-123, and even these will not hold the frame firmly unless the brick or stonework is solidly built around them. The author strongly favors the use of iron anchors for securing the frame, and especially when the doors are large and heavy. Two iron anchors of the shape shown in Fig. 126, screwed to the back of each jamb, will

hold the frame securely, and they are not affected by shrinkage. If there is no wood threshold the bottom of the jambs should *always* be secured to the stone sill by means of iron dowels, either made as in Fig. 126 or let into the bottom of the jamb, and even where there is a wood threshold it is a good idea to use the dowels.

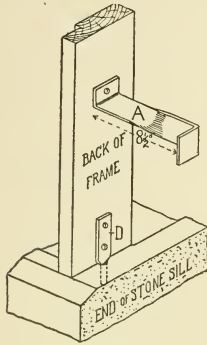

Fig. 126.

**108. Bulkhead Over Outside Cellular Stairs.**—An outside entrance to the cellar is almost a necessity in buildings that have a heating apparatus in the basement. This entrance is sometimes provided by means of a door opening at the ground level on to a landing of the cellar stairs, but more often it is provided by means of an outside stairway below the surface of the ground. In the Northern States this stairway should be covered to keep out the rain and snow, and also to make the cellar warmer in winter. As a rule, the stairway, sometimes called a "rollway," or "hatchway," is placed at the rear of the building, so as not to be conspicuous, and if there is

no window directly above in the first story, it is a good plan to build a shed or porch over the stairs, with a door at the head. When this is not practicable the stairs must be covered with "trap doors." This is generally accomplished in the manner shown by Fig. 127. A rough plank frame, *A, B, C, D*, is bolted to the side walls by  $\frac{3}{4}$ -inch bolts, about 18 or 20 inches long, which are built into the wall as it is laid, the nuts on the head of the bolts being sunk flush with the frame. The lower piece of the frame *B* is usually dressed and forms the upper step. When the underpinning is of brick the side walls above the ground are usually made 8 inches thick, and a single 2x8-inch plank is used for the frame.

After the frame is secured it is covered with matched pine boards or ceiling, and batted doors are hung to the frame by heavy strap hinges, as shown in the drawing. When a skeleton frame is used pieces of plank, *N, N*, should be placed under the hinges to receive the screws.

The only points in the construction of the ordinary "bulkhead" which will require especial attention are to see that the frame is bedded in mortar and securely bolted down, that the doors are nailed with clout nails well clinched, that the hinges are of proper size and

well secured, and that provision is made to keep water out of the stairway.

The cleats for the doors should be  $1\frac{1}{2}$  inches thick and  $5\frac{1}{2}$  inches wide, with a mortise cut in the edges of the frame to receive them. It is a good idea to bolt the hinges to the doors with  $\frac{3}{16}$ -inch carriage bolts, as nails are apt to work loose in time.

In the majority of buildings no especial provision is made for keeping the rain water from entering around the doors, but for all first-class residences, especially in those States which have a good deal of wet weather, the architect should make such provision in his speci-

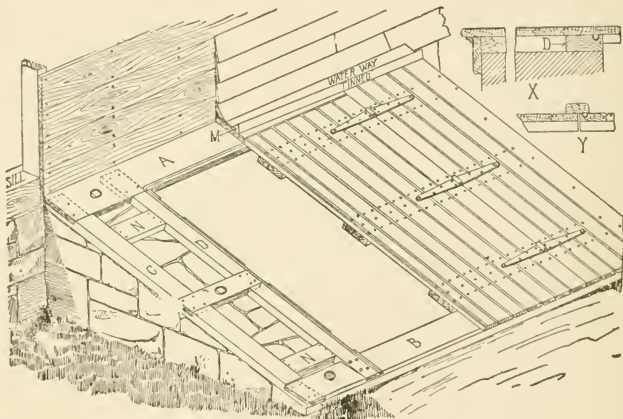

Fig. 127.—Outside Cellarway or Bulkhead.

cation. A beveled cleat, *M*, should be nailed to the casing above the doors, pitching to each side, and this cleat and the space back of it should be covered with lead, zinc or tin, which should extend at least 2 inches up on the sheathing back of the water table or siding. This will prevent the water that runs down on the wall from entering the joint above the doors. A small groove should also be made around the inner edge of the frame, as shown in the perspective, and also in section *X*, to carry off what little water may enter the joints. The meeting joints of the door may be protected by a batten, and a groove made in the edge of the standing door under the batten, as shown at *Y*. With these precautions but little water will



enter around the doors, and they will not be as likely to freeze up in winter.

**109. Superintendence.**—The superintendence of the work described in this chapter will ordinarily be a very simple matter, especially if the work has been explicitly specified and detailed.

In regard to the rough boarding, the only inspection needed will be as to the quality of the lumber and the nailing, and to see that it is put on as specified, *i. e.*, close or open and horizontal or diagonally.

Each board should have two nails at every bearing, preferably ten-penny nails, although eight-penny nails are commonly used. The superintendent should also see that the boarding under tin roofs has all projecting edges eased off, and if there are any small knot holes that they are covered with pieces of galvanized iron; large knot holes should not be permitted. (See Section 86.)

The frames should be examined as soon as they are delivered at the building, to see that they are made strictly in accordance with the details and that the lumber used is of the required quality and thickness. The particular points about the construction of the frames to be examined are those which are unusual in common work, such as the ploughing of the pulley stile into the outside casing and the rebating of the sill. The superintendent should also see that the back of the frames is painted before they are set, if this is specified (as it should be in good work). In brick buildings he should see that a piece of 2x4-inch studding is built into the wall under the window frames (see Section 93), and that the frames are set plumb and are well braced during the building of the wall. In brick and stone walls the frames are easily pushed in or out until they are walled in, and after the wall is up they cannot easily be corrected, consequently it is quite a common thing to see frames that are out of plumb (showing a narrower or wider reveal at the top than at the bottom). The pulley stiles should also be braced by a board set in between them to prevent the sides of the frames from being "sprung" toward each other by the brickwork.

In wooden buildings there is not much chance for the frames to move after they are once set and nailed, and it is only necessary to see that they are plumbed before nailing and that sheathing paper is put back of the outside casing when the casing is placed over the sheathing.

The plumbing and securing of the door frames in brick or stone walls should be carefully looked after, as it is even more important that these should be plumb and rigid than it is for the window frames

If a door frame is not plumb the door will not swing properly, and the slamming of the door soon loosens a frame that is not well anchored (see Section 107).

When the sashes are delivered they should be examined to see that they are of the specified thickness and that the glass is of the kind specified. Plate glass can easily be distinguished from other glass both by thickness and reflection, and, as there is practically but one quality, there is little chance of an inferior article being substituted. When sheet glass is specified it is not so easy to determine the quality, although single and double-strength glass can generally be readily distinguished, and first-quality glass should be free from flaws and streaks. If one of the special brands of glass is specified there will be no difficulty in seeing that it is furnished, as each light (in the first quality) is labeled with the trade mark.

All sashes and outside frames should be primed or oiled as soon as possible after they are delivered at the building.

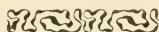

## CHAPTER IV.

### OUTSIDE FINISH, GUTTERS, SHINGLE ROOFS.

**II.** After a wooden building is sheathed or boarded the next step is generally to finish the eaves and gables, so that the roof covering can be put on, and thus protect the building from the weather. While part of the workmen are covering the roof others are usually employed in setting the windows and outside door frames and putting up the outside finish, preparatory to covering the walls with siding or shingles.

Sometimes the roof is shingled before the gable ends are finished, the shingles being kept back from the ends of the roof and filled out after the raking cornice is put in place. The gutter or eaves, however, must be finished, at least on top, before the roofers can commence work, and it is also necessary that all of the outside casings, corner boards, etc., be fixed in place before the walls can be covered.

**Outside Finish.**—The material for outside finish should be soft white pine, cypress or redwood, the last-named wood, however, being seldom used east of the Rocky Mountains, except for piazza posts or parts of large dimensions.

In the better class of buildings clear, well-seasoned stock is generally specified, but on cottages a few small knots are often permitted.

The various parts of the finish should be grooved and tongued together, wherever practicable, and the tongue painted with white lead and oil just before joining the pieces. All joints should be made so as to be protected from the weather as much as possible, and the pieces should be fastened with nails or screws without gluing. All nail heads should be sunk beneath the surface of the finish and the holes filled with putty.

**III. Eaves and Gutters.**—*Details of Construction.*—The principal considerations of a practical nature in designing the eaves of a building, and particularly of a dwelling, are to make proper provisions for carrying off the water that falls on the roof, whether in the shape of rain or snow, and providing sufficient projection to protect the walls from water dripping from the eaves. The projection and finish of the eaves also have a very decided effect upon the architec-

tural character of the building, and it is more often this consideration that determines the projection and finish.

Occasionally the eaves of dwellings are finished simply by a gutter with a small moulding underneath, the entire projection not exceeding 6 or 7 inches. When finished in this way they are called "close eaves." Close eaves, although they may answer the purpose in some localities, are not as satisfactory as projecting eaves, and are now seldom used except on dormers.

The holding and conducting away of the water is provided for by means of *gutters*. These may be made of wood, tin, galvanized iron or copper, and of various shapes. In England cast iron gutters are largely used in

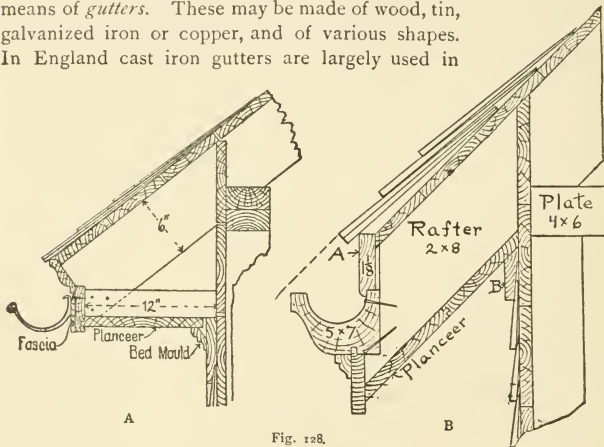

connection with wooden eaves, but the author has not heard of their being used in this country.

*Wooden Gutters.*—In New England wooden gutters are most commonly used on dwellings, and they have been found to be very durable. These gutters are worked out of solid pine or cypress, the common shape being that shown in Figs. 128 and 129. Several sizes of gutters are carried in stock by the larger lumber dealers of Boston and other New England cities, but the more common sizes are 4x6, 5x7 and 5x8 inches. In making the gutters the core is taken out in such a way as to be utilized in making wooden down spouts, or conductors.

When the length of the gutter between angles does not exceed 16 feet it may be made of one piece of wood; for greater lengths two

or more pieces are butted closely together and the joint covered with sheet lead tacked to the two pieces of gutter.

Cypress is the best wood for such gutters, with the possible exception of redwood, but white pine gutters have also been very extensively used in New England.

In nearly all other sections of the country the gutters are made of either tin, galvanized iron or copper; tin being used principally for lining a wooden form. The shape of metal gutters may be varied to suit the pitch of the roof or the taste of the designer, as, with the exception of cheap hanging gutters, metal gutters are not carried in

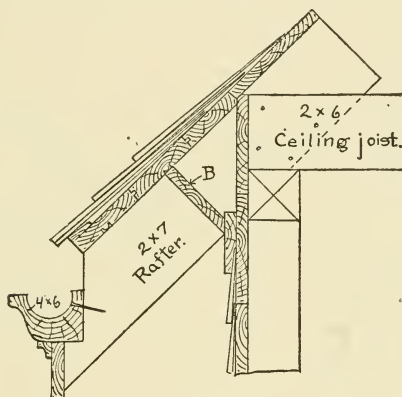

Fig. 129.

stock, but made to order as required. Metal gutters will be described in connection with the examples of eave construction.

**112. Examples of Wooden Eave Construction.**— The manner of finishing the eaves of buildings varies with the style of the building, and also somewhat in different localities, and even the same architect will vary his details more or less for each building that he designs, but all the common forms of wooden eave construction may be represented by four or five types. Brick and stone buildings, when erected in large cities, are generally finished with a stone, terra cotta or metal cornice, as wooden cornices are not usually permitted within the fire limits, and are also not as durable as the other materials, but outside of the fire limits brick buildings with pitch roofs are generally finished with wooden eaves in the same manner as

wooden buildings. On the cheaper class of buildings the construction shown in Fig. 128, A and B, is probably more commonly seen than any other, the wooden gutter being used in the New England States and a tin or galvanized gutter in other sections of the country. The planceer may either be nailed to the bottom of the rafters, as shown at B, or may be carried in level, as shown at A. This form of cornice is generally termed a *box cornice*, as the rafter ends are "boxed" in. When an open metal gutter is placed under the eaves of a box cornice, as at A, this construction answers its purpose very well, but when a wooden gutter is used, as at B,

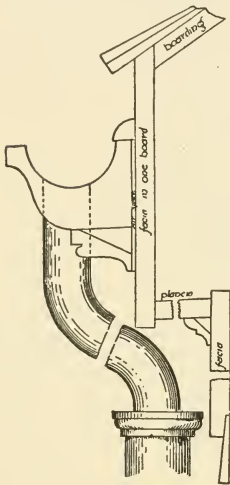

Fig. 129a.

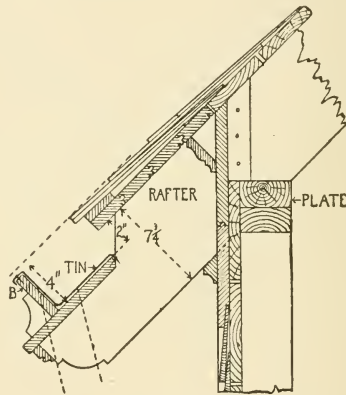

Fig. 130.

it has been found that in the Northern States during many days in winter snow is apt to lodge in the gutter, and the snow on the roof melting a little during the middle of the day, runs down to the snow in the gutter, where it freezes again, and in this way the ice *backs up* over the gutter and under the first two or three courses of shingles and drips down inside of the boxing, and sometimes inside of the walls, and the only way in which this can be prevented with a cornice like that shown at B is to tin the gutter and 2 or 3 feet up on the roof, which looks very unsightly.

Where wooden gutters are to be used, the best method of constructing the eaves, from a practical standpoint, is undoubtedly that

shown in Fig. 129. In this construction the rafters are exposed and there is an open space above the back of the gutter, so that there is little danger of ice backing up on to the roof. The rafter ends may be plain or ornamented, as desired, and if it is desired to use heavier material for the exposed ends than is necessary for the whole rafter, the rafters may be cut off on a line with the outside of the wall and false rafter ends spiked to them and to the plate, as shown in Fig. 131.

In the Northern States, and wherever the building is much exposed to the wind, a board (*B*, Fig. 129) should be cut between the rafters and let into them about  $\frac{1}{4}$  inch to keep the attic warm and to prevent snow from being driven through the cracks.

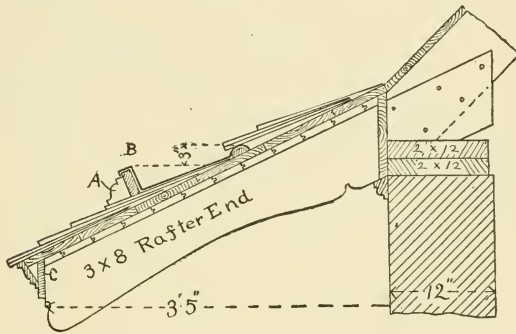

Fig. 131.

Where it is not practicable to leave an open space above the gutter the method of applying the gutter shown in Fig. 129*a* is believed to be the best.

In the Northern States when gutters are placed under the edge of the roof, as in Figs. 128, 129 and 132, the outer edge should be kept just a little below the line of the roof so that the snow may slide off without striking the gutter. Very often the first course of shingles is raised  $\frac{1}{2}$  inch above the roof boarding, as shown in Figs. 128 and 129.

The projection of the eaves may, of course, be made to suit the taste of the designer, but with common box cornices the back of the fascia is generally set about 12 inches from the wall line. Open cornices generally have a projection of from 18 inches to 4 feet, the heavy projection being used principally for the effect of the shadow, and in warm climates to make the rooms cooler.

**113. Tin-Lined Gutters.**—In many localities a form of gutter like that shown in Fig. 131 is most commonly used. This gutter is formed by setting a strip of board, *B*, 3 or 4 inches wide on top of the shingles a few inches from the edge of the roof, with brackets, *A*, placed against it about every 24 inches to keep it in position. The V-shaped gutter thus formed is lined with tin, which should be tacked to the upper edge of the board *B*, and the upper edge of the tin should be turned over a half-round cleat nailed to the roof boards. The top of this cleat should be at least  $2\frac{1}{2}$  inches vertically above

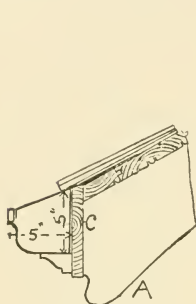

Fig. 132.

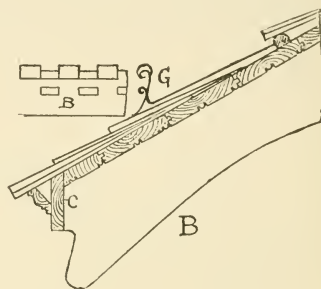

Fig. 133.

the edge of the board *B*, and on steep roofs it is better to make the distance 3 or 4 inches.

Fig. 133 shows a similar gutter made entirely of galvanized iron or copper.

Either of these gutters may be placed on any projecting eaves, whether open underneath or boxed in.

The only objections to this type of gutter that the author has met with are that they retain more or less snow, thus permitting the water to back up on the roof in cold climates, and the slight projection of the roof below the gutter catches some rain, and thus gives a slight drip. Such gutters also rather detract from the appearance of the roof. When used they should always be placed outside the wall line.

Fig. 130 shows a form of eaves construction which is very similar to that shown in Fig. 129, the only practical difference being in the form of gutter used. The gutter in Fig. 130 is made in about the same way as the gutter described above, but instead of being placed on the roof is dropped below it. The board *B* should be  $1\frac{1}{2}$  inches



thick ; the brackets may be of any desired shape. This makes a very desirable cornice for medium-priced houses, especially in the Northern States, but it requires at least 8-inch rafters to form the gutter.

Tin-lined gutters are also very commonly formed in the top of a heavy box cornice, especially when the roof is quite flat or when the cornice is at the base of a French roof. Fig. 137 shows the manner in which the gutter is generally formed, and Fig. 82 shows the same method applied to cornices surmounted by Mansard roofs. Such gutters should be of ample size, with a good pitch to the bottom, and the tin should be carried to a considerable distance above the gutter.

For lining gutters copper is the most durable material, but on account of its cost is seldom used except on the most costly buildings, tin being used instead. Only the best quality of roofing tin should

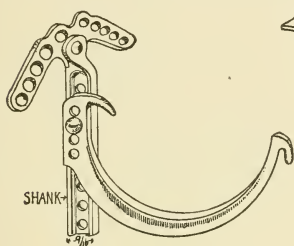

Fig. 134.

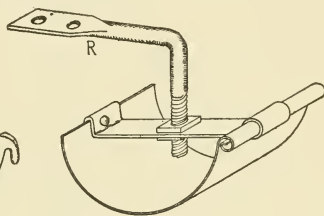

Fig. 135.

Eave Trough Hangers.

be used, and it is always better to use the IX thickness, as it is less easily punctured. The tin should be painted on the under side before it is put in place, and should be painted on the exposed side afterward.

**114. Eave Troughs and Galvanized Iron Gutters.**—In most instances the simplest method of taking care of the water from the roof is to place a galvanized iron or copper gutter under the outer edge, and in large cities this method is probably more often followed than any other. In small places where there are no shops for making gutters tin-lined gutters or wooden gutters are the cheapest.

Gutters placed on the outer edge of the eaves may be made of many shapes, the simplest being in the form of a half-round trough, as shown in Fig. 128, *A*, and Fig. 135. These troughs are usually either hung from the edge of the roof by a hanger such as is shown in Fig. 135 or supported by iron brackets, as shown in Figs. 128A

and 134. The troughs are usually made of galvanized iron and of the shape shown in Fig. 135, this being a stock pattern. On sheds and very cheap buildings tin gutters are frequently used, but they are far from durable and cannot be recommended. Where some pretense to ornamentation is made, as in Fig. 136, the gutter may be made of 16-ounce cold rolled copper, which, while much more expensive, will last almost forever.

When eave troughs are used the author recommends that the Berger Hanger, of which one pattern is shown in Fig. 134, be specified (unless an ornamental bracket is preferred), as such hangers are far superior to the cheap affairs ordinarily used by tanners. The Berger

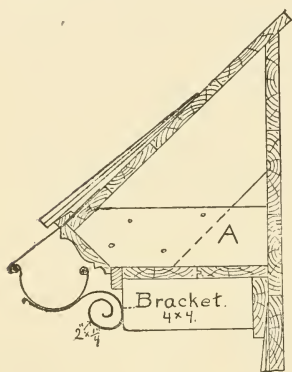

Fig. 136.

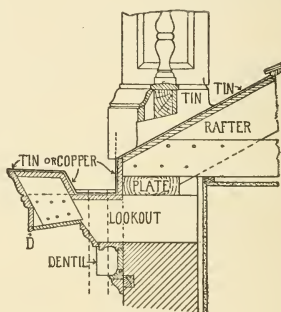

Fig. 137.

Hanger is made in two parts—the shank and the hook—which are bolted together. Several styles of shanks are made so that they may be screwed to the fascia or to the side of the rafter, or nailed to the top of the roof boarding. The hook is made 4, 5, 6, 7 and 8 inches wide. By means of the holes in the shank and hanger the height of the hook on the shank may be varied from  $\frac{1}{8}$  inch to  $2\frac{1}{2}$  inches, so as to give a fall to the gutter. These hangers can be applied to any cornice, old or new, and the hook may be readily adjusted at any time. They cost only about 6 cents apiece.

When no particular hanger is specified, one similar to that shown in Fig. 135 is generally used, as it costs 2 or 3 cents less than the Berger Hanger. Such hangers, however, are very flimsy affairs, and not suitable for good buildings.

Eave troughs, when made of good material, with slip joints, make a very practical gutter, and one which cannot very well get out of order, and if a leak occurs it will not damage the building. They are not very ornamental, however, and their use is therefore generally confined to cottages, stables, porches, etc.

Next to the eave trough, the simplest metal gutter for the edge of a roof is that shown in Fig. 132. This form of gutter is very extensively used. It makes a neat finish and answers its purpose very

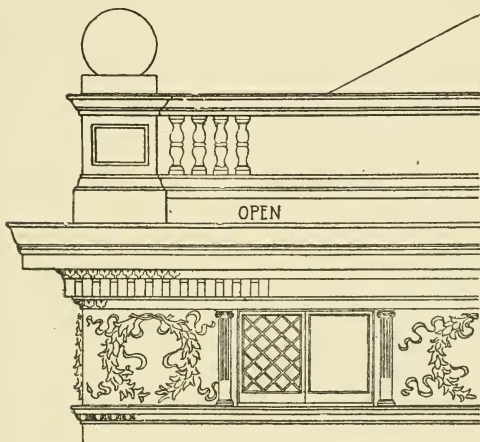

Fig. 138. -Cornice. F. R. Comstock, Architect.

satisfactorily when provided with a sufficient fall to the outlets. It is rather more expensive in most localities than a wooden or tin-lined gutter. When used it should be made either of galvanized iron of not larger gauge than No. 26 (24 is to be preferred) or of 16-ounce cold rolled copper. All end joints should be soldered and riveted unless the gutter is very long, when one or more expansion joints should be provided. The back of the gutter should be turned up on the roof at least 3 inches.

About the only trouble that the author has experienced with this type of gutter is that when applied to overhanging eaves it is usually necessary to make the gutter level, and when this is done the gutter after a time gets clogged with dirt and leaves, thus preventing the water from draining perfectly and permitting it to freeze in the win-

ter months, thereby often opening the joints in the gutter. Where the lengths of gutter are short and the cornice has a good projection the want of a pitch to the gutter does not give serious trouble, but where the lengths are long or the projection very slight the gutter should always have a fall to the outlet of at least 1 inch in 20 feet. With a single gutter this fall is obtained by making the back of the gutter higher at the low end than at the other. The author has found that metal workers seldom give any pitch to such gutters unless it is specified.

When a metal gutter forms the crown member of a box cornice, as in Figs. 140 and 141, it is almost necessary that the exposed face of the gutter shall be level. To secure this, and also a pitch to the gutter, it is customary to make a false front for the gutter, as shown in the drawings. This front is set level, but the gutter proper has a pitch of an inch or more, as may be desired. Wherever metal gutters are used on brick cornices this arrangement should *always* be adopted.

There is a slight objection to having the gutter at the very edge of a heavy projecting eaves, in that it requires a heavy goose-neck or a long piece of pipe to connect the gutter with the top of the conductor, and such connecting pipes, being necessarily quite conspicuous, often mar the appearance of the building. For this reason many architects prefer with such cornices to place the gutter on top of the roof, as in Figs. 131 and 133, as by this arrangement a much shorter connecting pipe may be used, and it is also much less conspicuous.

When drawing the detail of gutter and cornice the draughtsman should always consider how the gutter is to be connected with the outlet pipe, and locate the gutter so that a neat and practical connection may be made. The outlet pipe should always cut through the bottom of the gutter, but may be cut on a slant if more convenient.

**115. Wooden Cornices on Brick Buildings.**—Wooden cornices, when used on brick or stone buildings, are built in practically the same way as on wooden buildings, except that in brick buildings it is frequently necessary to build plank brackets, or "lookouts," into the wall to support the woodwork. Ordinarily, on brick dwellings, the wall fascia comes down but 1 or 2 inches on to the brickwork and is nailed to the plate, but occasionally it is desirable to cover up a foot or more of brickwork, as in Figs. 137 and 139, in which case it is necessary to build nailing strips into the wall at the proper height to hold the finish.

The varieties of cornice construction are innumerable, and their shape is more a matter of taste than of construction, the gutter, as has already been stated, being the principal constructive feature.

As an aid to the architect in deciding upon the style of cornice to be adopted, and in detailing the same, a number of details are given of various styles of cornices, which, with those already referred to, may be considered as covering every type of wooden cornice.

Figs. 137-141 show various styles of box cornices, *i. e.*, those in which the supporting timbers are concealed.

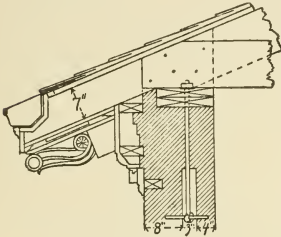

Fig. 139.

Fig. 137 shows the manner in which a classical cornice like that shown in Fig. 138 is generally constructed. The finish, and also the gutter, is nailed to plank lookouts built into the wall about every 24 inches. With wooden walls these lookouts are spiked to the side of the studding. The shape of the mouldings may be varied to suit individual taste, but the pieces should be put together about as shown, and a drip should always be provided at the point *D*. The bottom of the gutter should be inclined toward the outlets, and the tin should be carried well up on the roof, as shown.

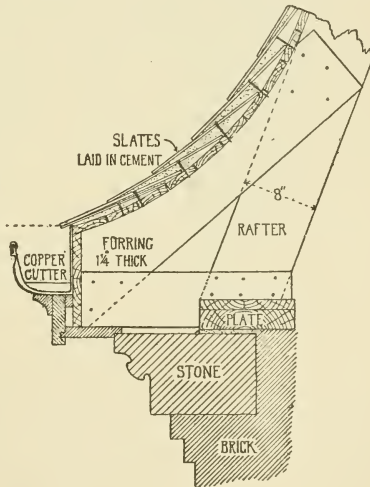

Fig. 140.

When the gutter is surmounted by a balustrade especial pains must be taken in tinning about the posts, and the bottom rail of the balustrade should be kept at least 2 inches above the roof.

In the Northern States snow is quite sure to lie back of such balustrades, and the roof should be tinned for a considerable distance behind the railing, as shown in the figure.

Fig. 139 shows a section of the cornice of the Burnham Athenæum, Champaign, Ill., Mr. J. A. Schweinfurth, architect. The soffit of the cornice is paneled and the brackets are spaced from 2 to 3 feet apart. This makes a very suitable cornice for a classical building with a low pitch roof.

Fig. 140 shows a common method of forming a wooden cornice at

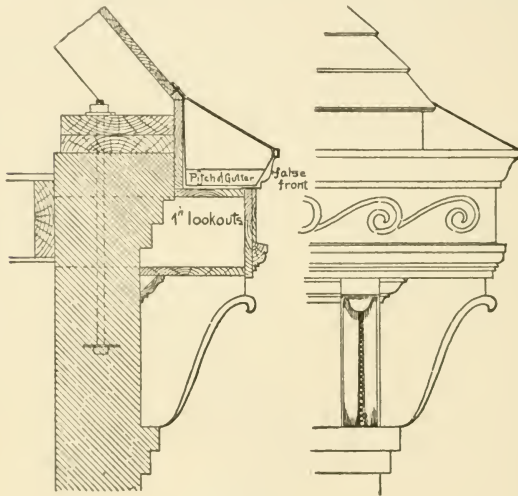

Fig. 141.

the base of a Mansard or gambrel roof, where the walls are of brick. The double gutter shown has already been described, and should always be used on such cornices. The wall plate should, of course, be bolted to the wall in the manner shown in Fig. 139.

Fig. 141 shows a box cornice used by the author on a brick city residence in Denver, Col. A stone or terra cotta cornice would have been more appropriate, but could not be afforded. The gutter is the same in construction as that shown in Fig. 140, the crown moulding being level, while the bottom of the gutter has a fall of about 1 inch.

Fig. 142 shows a section of the cornice on a grammar school building designed for the city of Boston by Mr. E. M. Wheelwright. The especial feature of this cornice is the manner in which the rafter ends are supported, it being in this respect rather unique. Usually the rafter ends are made self-supporting, as cantilevers, and in this case the only necessity for the lower brackets and beam is to satisfy the eye rather than to support the rafter ends. For a heavy building,

however, such a cornice seems very effective, and would probably stand longer in case of fire.

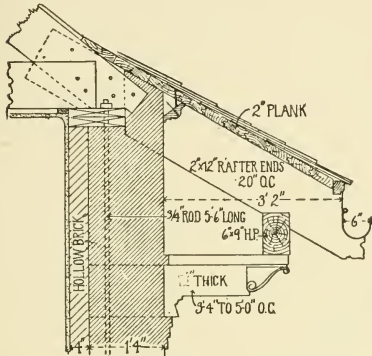

Fig. 142.

Open wooden cornices, *i. e.*, those in which the rafter ends are exposed, appear to be very popular at the present time, and they certainly make the best construction, both in durability and safety from fire.

Elaborate cornices generally have the rafter ends made of white or

Southern pine, dressed for painting or varnishing and spaced at regular intervals. They are supported on the wall plate and by spiking their upper ends to the common rafters or to planks cut between. The roof boarding over the projection must be of sufficient thickness that the shingle or slate nails will not go through. A covering of  $1\frac{3}{4}$ -inch planks matched and beaded is undoubtedly the best as it affords a good "hold" for the nails and is slow burning. On dwellings, however, it is more common to cover the rafter ends with  $\frac{3}{4}$ -inch white or Southern pine ceiling, dressed side down, with the usual roof boarding or sheathing laid on top. A single thickness of  $\frac{3}{8}$ -inch ceiling is hardly sufficient to make a good job, although it has been used for shingled roofs. The rafter ends are generally sawn to a pattern, and they have a better appearance when 3 or 4 inches thick.

Fig. 143, from a house at Germantown, Pa., Frank Miles Day & Bro., architects, shows rather an unusual method of forming the gutter in an open cornice, with a tile roof. The idea was evidently to conceal the gutter and permit of a thin edge to the roof. As shown

in the elevation, a portion of each tile was placed across the gutter, and, aside from the looks, the author would regard this as a very important precaution, as these tiles will prevent snow from lodging in the gutter, while without them such a gutter would be likely to fill solid with snow and ice.

**116. Conductors.**—The pipes which conduct the water from the gutter to the ground or drain are variously termed “conductors,” “leaders” or “down-spouts,” the first term probably being in most general use.

In the New England States, and possibly in some others, wooden conductors are often used on dwellings, but in most localities metal conductors alone are used.

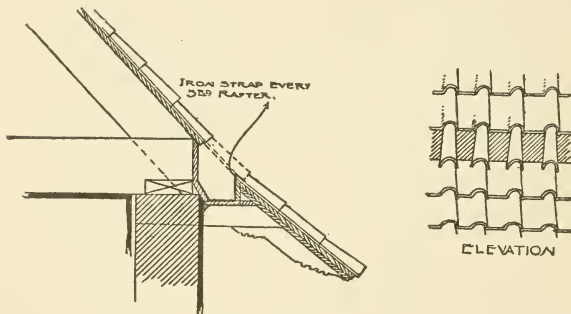

Fig. 143.

The wooden conductors used in New England are made of two semi-cylinders of wood, about  $\frac{5}{8}$  inch thick, grooved and splined at the edges. These semi-cylinders are cut from the hollow portion of wooden gutters, so that the material practically costs but little. They are made of white pine or cypress, the latter wood being far the more durable, and from  $1\frac{1}{2}$  inches to 3 inches inside diameter. They are usually painted the same color as the trimmings of the house. Fig. 144 shows a patented section, made in Boston, of three pieces, with wall iron attached. Except for the danger of being split by the water choking up and freezing, cypress gutters are fully as durable as galvanized iron pipes, and much more durable than tin pipes. These conductors may be finished at the top by a wooden moulding, turned in two parts and nailed to the pipe; at the bottom they are usually cut off square about 12 inches above the ground. If they



are to be connected with the drain, the lower end may be inserted in a piece of iron soil pipe.

*Metal conductors* are usually made of galvanized iron, although tin is sometimes used on buildings of very moderate cost, and copper on public buildings and the best class of private buildings.

Tin conductors are soon eaten through by rust and are not at all economical in the long run; they are also easily dented.

Copper is the most durable of all materials and should be used when the rest of the construction will warrant the expense.

Galvanized iron, however, makes a very durable conductor, when kept painted, and if made of suitable thickness is not easily dented. For ordinary conditions No. 27 iron is sufficiently heavy, but where the pipe is exposed to hard usage, No. 20 or No. 22 iron should be used.\* Copper conductors are usually made of either 14-ounce or

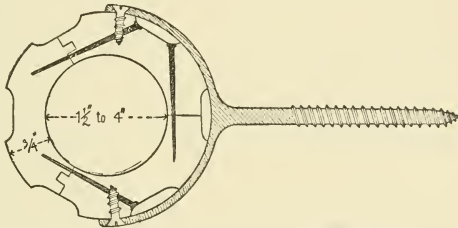

Fig. 144.—Stearn's Patent Cypress Conductor and Malleable Wall Irons.

16-ounce cold rolled copper. With both metals the joints should be both soldered and riveted. Metal conductors may be round, octagon or rectangular in section, but should contain some provision for expansion in case of freezing solid, as often happens. A corrugated round pipe makes an excellent conductor and the square or octagon shapes permit of some expansion, but a plain round pipe permits of none. Corrugated round and rectangular pipes are carried in stock in many cities, but it costs but little more to have the pipes made to order, and many metal workers make their own conductor pipes. When made to order they may of course be moulded to suit the taste of the architect.

The section at *A*, Fig. 145, shows quite a common section for cus-

\*The thickness of all sheet iron and steel is measured by the United States Standard Gauge, which varies in numbers from 7 to 30, the larger number being always the thinnest. See table in Appendix.

tom-made pipes, while the section at *B* is the stock pattern. Rectangular conductors generally look better than round ones, and are hence more often used where a fine appearance is desired.

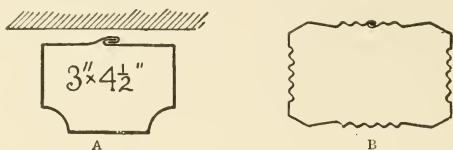

Fig. 145.

The stock sizes for metal conductors are 2, 3, 4, 5 and 6 inches for round pipes, and  $1\frac{3}{8} \times 2\frac{1}{8}$ ,  $2\frac{1}{2} \times 3\frac{1}{8}$ ,  $3\frac{1}{8} \times 4\frac{3}{4}$  and  $3\frac{3}{4} \times 5\frac{3}{4}$  inches for corrugated rectangular pipes. Special pipes may be made of any size.

On good work metal conductors are usually finished at the top with ornamental caps, which may be made of various shapes, a common one being shown in Fig. 146.

Conductors should be secured to the wall by malleable iron fittings made for the purpose; these are usually driven or screwed into the wall about 5 feet apart, and screwed to a wooden conductor, or wired to a metal one.

*Goose-Necks.*—The connection between a wooden conductor and the gutter is usually made by a lead pipe, called a “goose-neck,” from its often being bent to that shape. For 3-inch conductors  $2\frac{1}{2}$ -inch pipe should be used, and for 4-inch conductors 3 inch pipe. Lead goose-necks are occasionally used with metal conductors, but more often a piece of pipe, either straight or curved, is used to make the connection; in fact the author has never seen a lead “goose-neck” in the West. When the conductors have ornamental caps the connecting pipe is merely placed inside of the cap. The goose-neck or pipe should be soldered to a tin or metal gutter—generally a short piece of pipe is soldered to the gutter, and the connecting pipe slipped over it.

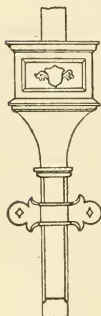

Fig. 146.

*Waste from Conductors.*—Wherever possible the conductors should be connected with the sewer by means of earthenware drain pipes, laid below the frost line and securely trapped. The trap should also be provided with a clean-out.

When the conductors cannot be connected with the sewer, dry

wells filled with stones may be sunk 10 to 20 feet from the building and drains laid to these.

On isolated dwellings, troughs of stone, cement or wood, laid above the ground, may be used to carry the water away from the walls, but in no case should the water from the conductors be allowed to run down on the foundation walls.

**117. Conductors Carried Inside the Walls.**—It is often

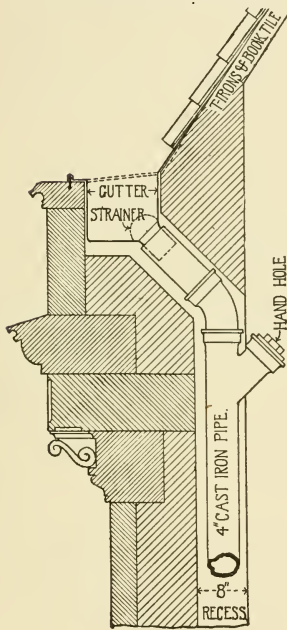

Fig. 147.

desirable and sometimes necessary to place the conductors on the inside of the wall. In such cases 4-inch cast iron soil pipe should be used (cast iron does not rust or corrode as badly as wrought iron) with joints caulked and soldered. Especial pains should also be taken to protect the pipes from frost, and if possible they should be perfectly straight and perpendicular. When practicable it is a good idea to fur the outer wall so that the conductor may be kept entirely inside of the wall line; when this is not practicable, a recess should be left in the wall for the pipe, but there should never be less than 9 inches of wall between the pipes and the outer air, and it is advisable that the space around the pipe be packed with mineral wool. When the building is heated by steam, a steam pipe may either be run up beside the conductor, or a Y may be placed in the conductor in the cellar

and a steam pipe connected with it.

The upper end of the conductor should always be protected by a galvanized wire screen, to keep out leaves and other solid substances, and, where practicable, a hand hole should be provided near the top. Fig. 147 shows a detail for an inside conductor in a building designed by Frederick W. Perkins, architect.

**118. Gable Finish.**—The gable ends of the roof on wooden

buildings are usually finished to correspond with the eaves. If the eaves have a close finish, a similar finish is carried up "on the rake" of the gables. When a box finish is used for the eaves, the "raking cornice" is usually boxed out to correspond. Rake mouldings of the same section as the eave mouldings will not mitre at the intersection (*i. e.*, if the eave mouldings are plumb), and to make a proper intersection the rake moulding should be worked to fit the eave moulding, as shown in Fig. 148.

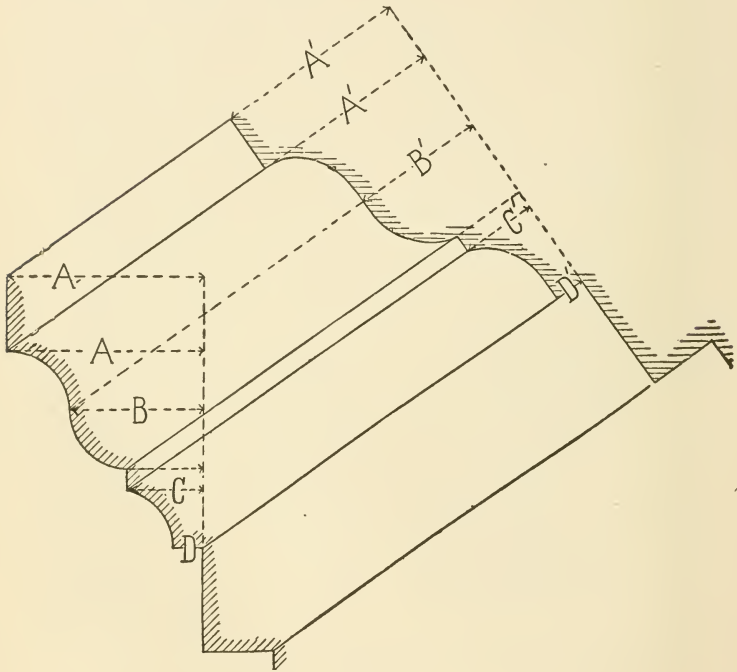

Fig. 148.

The rake moulding is obtained by drawing lines parallel to the pitch of the roof from the angles of the eave moulding, and making the projection  $A'$ ,  $B'$ , etc., of the same length as the corresponding projections of the eave mould.

A moulding obtained in this way will not make a true mitre, but it is the best that can be done. When the eave moulding is set at right angles to the roof, as shown in Fig. 153, a rake moulding of the same section will mitre perfectly. A moulding set in that way, however, does not look as well as when vertical.

In classical buildings, the cornice, with the exception of the crown mould, is always carried across the end of the building, and the raking cornice finishes on top of it. In Colonial work, and particularly on buildings with a gambrel roof, the cornice was often returned a short distance, at the gable ends, to make a stop for the gable finish, as shown in Fig. 149, and this method is still often followed.

The correct method of returning the cornice under a gable is

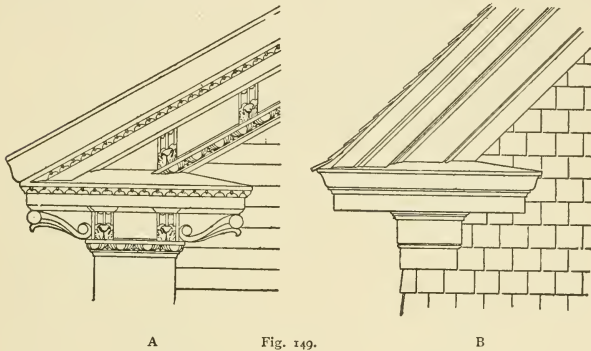

A

Fig. 149.

B

that shown at *A*, but the method shown at *B* is more often adopted on wooden buildings. The top of the return should be set on a bevel and covered with metal.

The gable finish when boxed is supported by spiking lookouts, 2 or 3 feet apart to the wall, and nailing a plank to their outer ends, as shown in Figs. 153 and 154*a*. The roof boarding and mouldings are then nailed to the outer plank, and the planceer or soffit is nailed to the under side of the lookouts.

When the eaves are finished with the rafter ends exposed, the gable ends are usually finished either with ornamental rafters, projecting 16 or more inches from the wall, as in Fig. 150, or by verge boards. The ornamental rafters may be supported by heavy brackets at the bottom, and by the ridge at the top, or by lookouts; generally

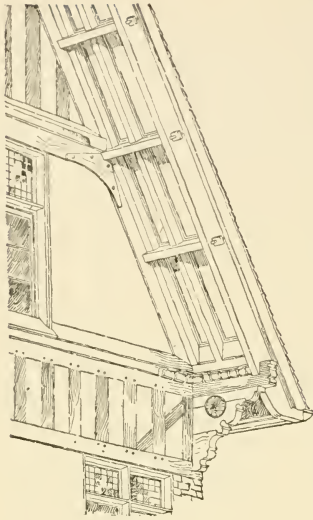

Fig. 150.

quently made plain, with chamfered edges. They should be made at least  $1\frac{1}{8}$  inches thick when the panel moulds are "planted" on, and not less than  $1\frac{3}{4}$  inches thick when carved or chamfered. When more than 12 inches wide they should be framed for regular panel work with  $1\frac{3}{4}$ -inch rails and stiles.

both are used, as in Fig. 150, and the lookouts are tenoned and pinned to the outer rafters.

**119. Verge Boards.**—Verge boards (sometimes called barge boards) are almost invariably used on frame buildings of the English Gothic or Tudor styles of architecture, and they may be used with almost any style of finish except the classical.

They are often highly ornamented by carving or panel work, although they are fre-

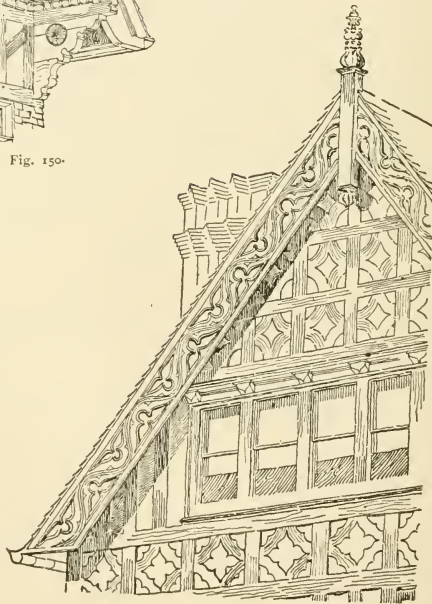

Fig. 151.

Verge boards are applied and supported in many ways, some of the more common being shown in Figs. 151-155. With open eaves the

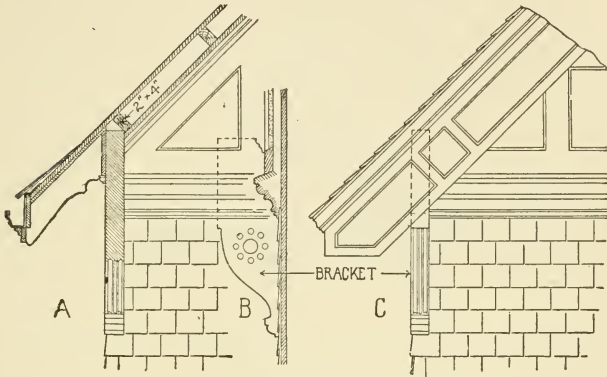

Fig. 152.

verge boards are generally, although not always, supported at their lower end by wooden brackets, which also serve to stop the gable mouldings, or belt courses, as shown in Figs. 150 and 152, the bracket being used more to stop the gable finish than for an actual support.

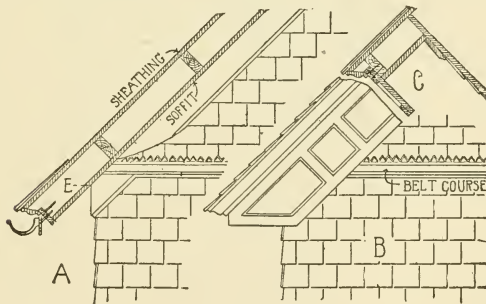

Fig. 153.

With an eaves finish like that shown at *A*, Fig. 153, with the soffit of the eaves and raking cornice in the same plane, the verge board

may be supported as shown in Section *C* without brackets, in which case the belt courses on the gable, if any, should be placed above

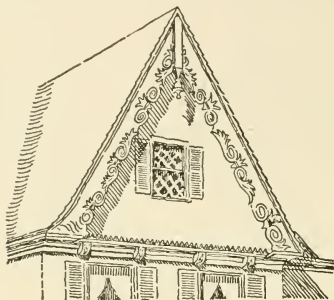

Fig. 154.

the point *E*, unless they are to be carried around the sides of the building. The wall under the soffit should be finished with a board

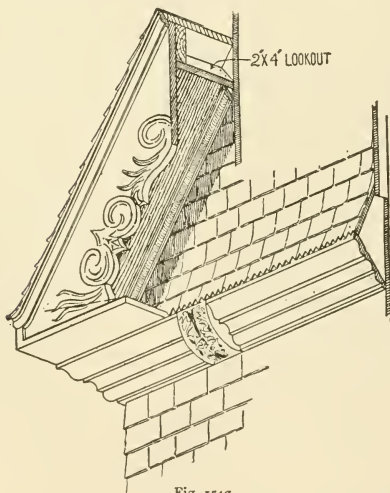

Fig. 154a.

to correspond with the fascia under the eaves. The projection of verge boards is seldom less than 14 inches.



Fig. 154 shows a rather peculiar method of stopping the verge boards, with close eaves; a ledge or shelf being formed to close the lower end, as shown in the enlarged detail, Fig. 154a, and the eave mouldings being returned under it, to form a belt course. Fig. 155 shows a very similar construction used in connection with a horizontal soffit to the eaves; in this case it is the only suitable method of stopping the verge board. The top of the ledges or shelves shown in these figures should be pitched outward and covered with tin or zinc.

*On brick and stone buildings* of a public or enduring character, and on all city buildings, the gable walls are generally carried above the roof and coped with stone or terra cotta, but on dwellings not within the fire limits the gables are usually finished the same as on wooden buildings, the lookouts which support the raking cornice

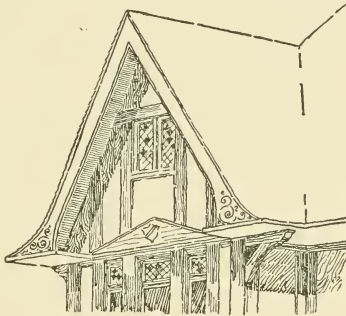

Fig. 155.

being built into the brick or stonework. Wooden cornices are much cheaper than stone or terra cotta cornices or coping, and on suburban residences they seem more appropriate and are sufficiently durable. A plank should be bolted to the top of the wall to receive the sheathing and to stay the wall. If the finish is very deep it will also be necessary to build bond timbers or wooden bricks into the wall at intervals to nail the finish to.

#### 120. Water Table, Corner Boards and Belt Courses.—

At the bottom of all wooden walls and just above the masonry wall there should be an offset or water table to throw the water which runs down the wall away from the mason work. Fig. 156 shows a section of water table that is much used and which answers every

purpose. The flashing shown by heavy line is often omitted, as it is not necessary if the siding is tightly fitted on the board *b*.

Very often, when stone walls are used for the underpinning, the wooden sill is placed 3 or 4 inches in from the face of the wall, thus giving a greater projection to the water table, but the construction is essentially the same.

**Corner Boards.**—When a wooden wall is covered with siding or clapboards, it is necessary to finish all the angles of the building with boards, put on vertically, for the siding to butt against. These boards are called "corner boards," and when plain are usually from 4 to 5 inches wide on external angles, and 2 or 3 inches wide at internal angles. On "Colonial houses" the corner boards are frequently made in the shape of pilasters, from 10 inches to 18 inches wide and  $1\frac{3}{4}$  inches thick.

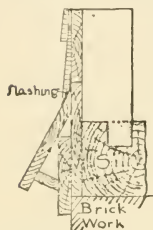

Fig. 156.—Water Table.

When the walls are shingled corner boards are not needed, and are therefore seldom, if ever, used.

**Belt Courses.**—Wooden belt courses are frequently placed on the walls, or across the gable ends of wooden buildings, and occasionally on brick buildings. They are generally built up of thin stuff, as shown in Figs. 152 and 154*a*, nailed to forms or furring blocks, which are nailed to the sheathing of a wooden house, or to bond timbers or lookouts on a brick one. They may be constructed in any shape, to suit individual taste, but the top should always pitch outward so that the water will run off freely, and a good drip should be provided at the outer edge. Where the top joins the wall it should be flashed with tin, lead, zinc or copper, about 4 inches wide, and very often the entire top is covered with tin or zinc. On shingled walls the shingles are usually brought out over the belt course, as in Fig. 154*a*, in which case flashing is not required.

## COVERING OF WOODEN WALLS.

**121. Siding or Clapboards.**—The walls of wooden buildings are usually covered either with shingles, siding or clapboards. In most localities it costs less to cover a wall with siding or clapboards than with shingles, and hence when the cost is an important item siding is generally used. When of good material and properly used, siding or clapboards make a good and durable wall covering, and, as they have a more finished appearance than shingles, many persons prefer them on that account.

Clapboards, in the strict use of the term, are a peculiar product of the New England States, and especially of Maine, the author never having heard of their manufacture in other localities, unless it be in the provinces. The clapboards made in Maine are 4 feet long, 6 inches wide,  $\frac{1}{2}$  inch thick at the butt and about  $\frac{3}{8}$  inch thick at the other edge, a cross section resembling that of the beveled siding shown in Fig. 157.

These clapboards are cut from the log by a circular saw, which cuts from the circumference to the centre, the log being hung as if in a lathe, being revolved the proper distance every time the saw takes off a board. Every board is of necessity perfectly quarter sawed, hence there is very little shrinkage and warping in them. When covering a building with clapboards the New England carpenters commence at the top and work down, as the clapboards can be laid faster in that way and with much less expense in staging. Clapboards should be free from knots or sap and should be closely butted at the end joints. The best Eastern clapboards are made out of

white pine, although more clapboards are now made of spruce, and even hemlock clapboards are sometimes seen.

*Siding.*—Outside of the New England States "siding" is used instead of clapboards for wall covering, and it is also coming into use in some portions of New England.

The common siding has a similar section to that of clapboards, but is a little thicker, and is

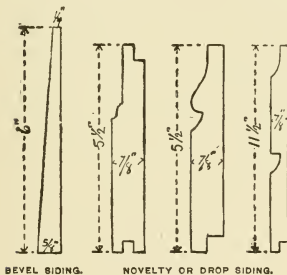

Fig. 157.

sawed from the log in the same manner as boards, and in lengths of from 10 to 16 feet. The ordinary siding, too, is not quarter sawed.

Siding has the advantage over clapboards in that there is usually much less waste in cutting, short splicing is avoided, and there are less joints. The common bevel siding is applied in the same way as clapboards, working from the top downward; the end joints should be carefully butted, and for the best work the ends should be dipped in white lead and oil and should come over a stud. Six-inch siding or clapboards are usually laid with an exposure to the weather of  $4\frac{1}{2}$  inches. In some localities beveled siding is furnished in 4, 5 and 6-inch widths, but 6 inches is the ordinary width, the common section being that shown in Fig. 157.

In Boston, and possibly elsewhere, a rebated siding, as shown at *B*, Fig. 158, is carried in stock. Rebated siding possesses the advantage that the nails pass through only one piece of siding, and in case of shrinkage there is no danger of the clapboards splitting as there is when the nail passes through two pieces, as shown at *A*. It is also claimed that the rebated siding gives tighter joints, and that it can be laid more rapidly and with greater accuracy; it also lays close to the boarding, thus preventing any danger of splitting. The rebate is  $\frac{5}{8}$  inch deep; 5-inch siding showing  $4\frac{3}{8}$  inches to the weather.

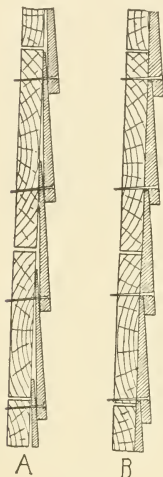

Fig. 158.

Beside the bevel siding various styles of moulded siding, usually called drop or novelty siding, are used (see Fig. 157). These are made from  $\frac{3}{4}$ -inch boards and have only about  $\frac{1}{8}$ -inch lap or cover. Such siding could be stuck to order at a slight additional expense.

The most durable woods for siding or clapboards are cypress and redwood, and one or the other of these woods can probably be obtained in most localities. Next to these woods soft pine makes the best siding. The harder pines are too brittle for beveled siding, as they split in nailing. Clear spruce is very largely used, but is not as good as the woods above mentioned. The best siding is quarter sawed; then there are generally a first and second quality, not quarter sawed, the second quality usually containing more or less sap, and in spruce a few small knots. Siding is often nailed directly to the studding without any sheathing or boarding between, especially in the Western States, but this should never be done except on summer cottages. A building covered in this way is very cold in winter and hot in summer, as well as much less rigid.

**122. Wall Shingling.**—Previous to about the year 1880 clapboards or siding appear to have been considered the only suitable covering for the walls of frame buildings of any pretensions, but with the advent of the modern country house shingles came rapidly into favor for covering the walls of dwellings, and even of public buildings, when of frame; many dwellings being completely covered with shingles from sill to ridge.

The choice of shingles or siding for wall covering is generally determined by the effect desired. As a rule, shingling a wall costs a trifle more than covering it with beveled siding or clapboards, but the difference is not usually a very big item. Shingles undoubtedly make a much warmer wall than clapboards, as where shingles are used there are usually three thicknesses at all points, while with siding there is practically but one thickness.

Probably the particular reason why shingles have been so much in favor for covering country and suburban buildings is that they are especially adapted to oil or creosote stains, by which an effect is produced that is not possible with siding or clapboards.

The shingles used for wall covering are of the same kind as those used on the roof (for description of shingles see Section 129), except that for the walls they are often cut to an ornamental pattern. For ornamental work it is best to use dimension shingles (shingles all of the same width), but for plain work this is not necessary, and even where the butts of the shingles are cut to a wave pattern random widths may be used. It is desirable, however, that wall shingles should not be wider than 8 inches nor narrower than  $3\frac{1}{2}$  inches.

The manner of applying the shingles to a wall is the same as on a roof, but a greater exposure of the butt is permissible, wall shingles generally being laid from 5 to 6 inches to the weather.

In finishing external angles the shingles are usually lapped over each other alternately, as shown in Fig. 153. At the sides of the window frames the joint should be flashed with either sheathing paper, tin or zinc, as explained in Section 92.

**123. Sheathing Paper.\***—It is well known that frame buildings,

\* The following, although necessarily restricted to a few lines, will give a general idea of the cost of different kinds and grades of sheathing papers, the price given being a fair average for the material applied to an outside wall or roof:

	Price per 100 Square Feet.
Common Tarred Felts (15 lbs. per square) .....	30 cents.
Red Rosin-Sized Sheathing, best grades .....	35 "
Manahan's Parchment Sheathing, single-ply .....	26 "
"    "    "    double-ply .....	40 "
"    Ship-rigging Tar Sheathing, 2-ply .....	75 "
" Neponset " Black (Waterproof) Building Paper .....	45 "
"    Red Rope Roofing Fabric .....	\$1.10
Sheathing Papers with Asphalt Centre .....	40 to 50 "
Johns' Asbestos Building Felt, 10 lbs. per square .....	42 "
"    "    "    "    14 lbs. per square .....	53 "
Cabot's Sheathing Quilt, single-ply .....	\$1.05
"    "    "    double-ply .....	\$1.25
Sawyer's Century Sheathing Quilt (Felt coated one side with a water and vermin-proof compound .....	\$1.25

when merely sheathed and clapboarded or shingled on the outside, and simply lathed and plastered on the inside, are almost sure to be hot in summer and cold in winter, and as the wood shrinks, as it is quite sure to do, cracks are made through which the wind finds its way. For these reasons some extra provision should be made for keeping out the wind and the heat and cold, and it is generally admitted that there is no material that will do this at so small an expense as properly prepared paper. The papers made for this purpose are commonly known as sheathing paper or building paper. There are a great variety of sheathing papers manufactured, many of them of great excellence, and even the best are comparatively inexpensive (costing only about \$1.00 per one hundred square feet), so that only the better qualities of paper should be specified.

The qualities which good sheathing paper should possess are toughness and impenetrability to air and water; they should not be brittle nor have a strong odor, and for the convenience of the builder should be clean to handle. There are so many papers made that possess these qualities that it is deemed inexpedient to mention particular brands, but the architect should decide for himself from the samples with which he has probably been furnished as to what paper is best adapted to his particular conditions, and then specify that brand (giving also the manufacturer's name), rather than to leave it to the selection of the builder, who will be quite sure to be guided by the price rather than by the quality.

Tarred or saturated papers are not now considered desirable either for wall sheathing or for placing on a roof, as they soon become brittle, emit a strong odor and are very disagreeable to handle. There are some papers, however, like Manahan's Parchment Sheathing, which contain a very little tar, sufficient, it is claimed, to make them an antiseptic for all fungoid growth and dust germs, but not enough to give any undesirable qualities.

The old-fashioned rosin-sized sheathing is soft and spongy, and absorbs and holds steam and moisture, and hence is not desirable for outside sheathing.

Sheathing paper is usually applied just previous to putting on the siding or shingles. It is generally placed horizontally on the walls, and should lap about 2 inches and over the paper previously placed around the windows and doors.

If Cabot's Sheathing Quilt is to be placed under clapboards or siding, laths should be nailed vertically over the quilt opposite each stud and the siding nailed on the laths, otherwise it will be difficult

to get them on evenly, owing to the thickness and the elastic quality of the "quilt." Shingles, however, may be applied directly over the quilt.

The sheathing paper and the putting of it on should be included in the carpenter's specifications.

**124. Joining a Wooden to a Stone Wall.**—Suburban and country residences are often built with part of the walls of frame and part of stone, and as the young architect may be puzzled as to just how the walls should be joined we give an illustration (Fig. 159) of the method adopted in a house by Mr. Cass Gilbert, built some years ago.\*

It should be noticed that the stud *A* forms an anchor to keep the wall in place, sideways, and that the sheathing paper on the wooden

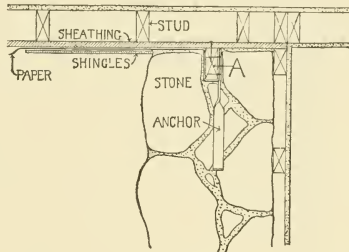

Fig. 159.

wall is extended around this stud, and the joint between the stone and the paper is filled with cement. The outer edge of this joint is concaved for the shingles to fit into. The stud *A* should also be anchored to the stone wall, so that in case of settlement the two will not separate.

**125. Porches.**—The building of a porch involves two kinds of work, the rough work which supports the floor and roof and the finished work, which is the part exposed to the eye.

The framing of porch floors has been described in Section 49. The rafters of the roof are supported by a plate or beam spanning from post to post or from post to wall, and usually enclosed by the cornice or by a false beam built up of  $\frac{3}{4}$ -inch pine boards. When the finished posts are round they usually form the support for the roof; if the posts are square a rough post is often set up to support the

\* This illustration was first published in the *American Architect* of March 14, 1885.

plate and a finished post built around it. Hollow posts should never be used to support any great weight.

Porches may be built and finished in so many different ways that it is impossible, in a work of this character, to allude to more than a few general features.

To begin with, the floor should rest on a solid foundation, brick or stone piers being the best, and all vertical wooden supports should be set with the fibres running vertically. All joints should be made so as not to be exposed to the weather, and the various parts should be neatly joined and well nailed together.

Porches built against brick or stone walls should have the upper portion secured to the wall by  $\frac{3}{4}$ -inch bolts set in the wall as it is built.

*Flooring.*—For the flooring hard pine should be used, and for first-class work the boards should be not over 4 inches wide,  $1\frac{1}{8}$  inches thick and quarter sawed, and, of course, free from knots or sap.

In regard to using matched flooring custom varies in different portions of the country. In the New England States it is customary to lay porch floors with open joints, the boards having square edges and being set about  $\frac{3}{16}$  of an inch apart, the nails being driven through the top. In other sections of the country matched flooring is generally used and nailed in the joints (blind nailed). The author is inclined to favor the open joint flooring, especially in localities where there is much rain or snow, although in climates like that of Colorado the tight flooring is perhaps more satisfactory. When the boards are matched they should have the tongue painted with thick white lead and oil just before the boards are laid, and the floor should pitch from the wall outward, about 1 inch in 8 feet, so that water will not stand on it.

When the sides of the porch are enclosed with a solid wall it is a good idea to run a narrow strip around the outside edge of the floor with a groove worked in and graded to form a gutter, and with holes bored through to let out the water.

When the porch is open the outer edges of the floor are finished with a nosing and cove, as shown in Fig. 161. Very often the ends or sides of the floor boards are rounded and the cove moulding placed underneath, and with open floors this is the best way, but with tight floors a solid moulding nailed to the edge of the floor, as in Fig. 161, makes a neater job.

The steps, if of wood, should be supported on plank strings set from 16 to 20 inches apart and resting on a flat stone or foundation



wall at the bottom. The treads should be  $1\frac{1}{4}$  inches thick, with the front edge rounded for a nosing, and the ends (when open) finished with a nosing planted on and mitred at the corners; a cove moulding is usually placed under the nosing. The ends of the steps are generally finished with a triangular panel, the panel being solid or made of lattice, according as it is small or large.

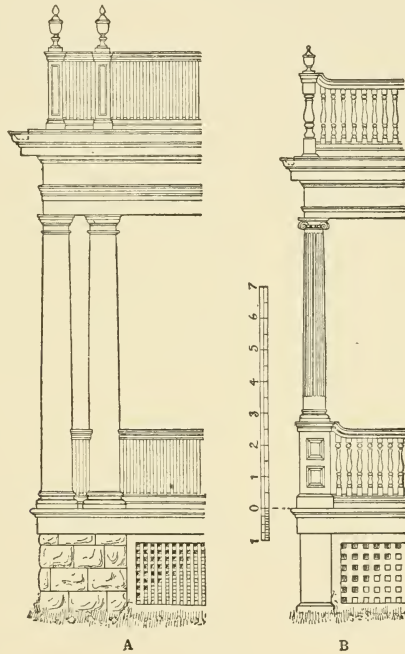

Fig. 160.

The sides and front of the porch beneath the floor, when of wood, are generally finished with wide pine casings with lattice work in the panels. There are two methods of forming this lattice work, the cheaper and more common one being to use lattice strips of stock size ( $\frac{1}{4} \times 1\frac{1}{8}$  inches) nailed over each other, as shown in Fig. 160, *A*, the vertical strips being on the outside. The strips should be set

so that the openings will be square and equal to the width of the strips, and the strips should be nailed together where they cross.

The other method is to use strips  $\frac{3}{4}$  inch thick and about  $2\frac{1}{2}$  inches wide and halve them together at the intersections, giving the appearance shown at *B*. This style of lattice undoubtedly looks more substantial than the other, but it costs two or three times as much. In putting up the lattice it is customary to nail the strips to the rough work of the porch and then nail the casings over the strips, but it is better, with a porch like that shown at *A*, to frame the casings together and to nail the strips to the back of the frame thus formed, so that it can be taken out should occasion require.

**126. Superstructure.**—In regard to the superstructure, the construction or putting together of the finish will depend a great deal upon the style of the porch, many porches being finished with cornice and gable to correspond with those on the house.

At the present time porches of the colonial or classical type are very much in vogue. These usually have turned posts which rest either on a pedestal or on the floor, as shown in Fig. 160. The choice of style is largely a matter of taste. When a post stands on a pedestal its diameter is decreased, and hence it can be turned from a smaller stick, and the decrease in the diameter also lessens the height of the cornice above, the proportions of the column and cornice being approximately those given by Vignola.

Posts less than 12 feet high are almost always turned from a solid timber, redwood or cypress being the best woods for the purpose, as they can be obtained in large sizes and free from knots, besides standing well.

The caps and bases are commonly turned out of pieces of planks with the grain horizontal. To make a neat job, the timber from which the post is turned should be at least 1 inch larger than the diameter of the column, so that the fillet at the top and bottom can be turned on the post. The columns will crack and check less if they are bored longitudinally through the centre.

The rails and balusters may be of such size and shape as suits the designer. Rails less than 4x4 inches in cross-section are usually "stuck" from a single piece of wood; when larger than this it is best to build them up.

It is a good idea to bevel the top of the rails slightly so that water will not stand on them, and a beveled top to the lower rail holds the balusters more securely. For residences not too pretentious in style plain balusters  $1\frac{1}{4}$  inches square, or  $\frac{3}{8} \times 1\frac{1}{4}$  inches when set about  $1\frac{1}{4}$

inches apart, make a neat and inexpensive railing. The builders of the better colonial residences generally used balusters 4 or 5 inches in diameter and a correspondingly heavy rail, as shown at *B*, Fig. 161, and such balustrades are still used. They are, of course, much

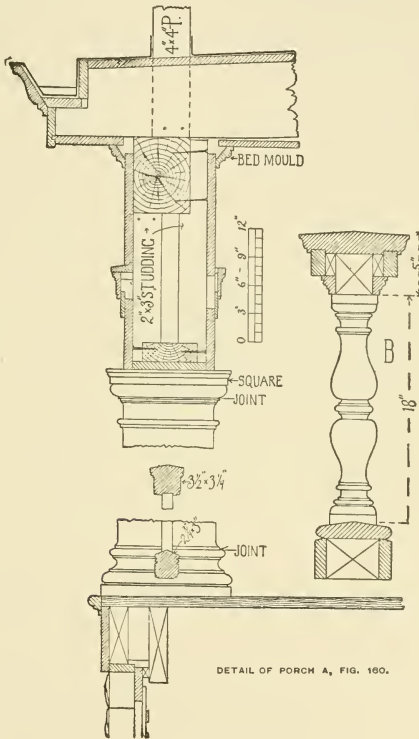

DETAIL OF PORCH A, FIG. 160.

Fig. 161.

more expensive than the other railing shown. The common size for turned balusters for porch or piazza railings is  $1\frac{3}{4}$  inches. The usual height of the rail from the floor is 2 feet 6 inches. The lower rail should be kept 2 inches above the floor to facilitate sweeping, blocks

being placed under the rail at distances of 4 or 5 feet to keep it from sagging.

When short posts are used they are usually nailed to the floor, and if they do not come at an angle of the porch should be further strengthened by iron angles screwed to the floor and post.

The construction of the cornice of porches such as have been described is illustrated by the enlarged section, Fig. 161. It should be noticed that the plate which supports the rafters is placed directly under the rafters and is supported over the columns by uprights formed of studding. The lower plate is suspended from the upper one between the posts, but when the fascia is on the cornice is really self supporting.

It is always desirable to provide the porch roof with gutters and conductors. When the roof is flat the gutter may be formed in the roof as shown. A pitch of  $\frac{3}{8}$  of an inch to the foot is sufficient for a tin roof.

If there is a railing above a tin roof the best method of securing the posts, if square and built up, is to extend a rough scantling from the plate 12 inches or more above the roof and turn the tin up around it, soldering the tin at the corners. The finished post is then set over it and is securely held, and without chance of leaks through the roof.

If turned posts are to be used they may be extended through the roof in the same way and the top of the tin turned into a saw-cut in the post, which should then be filled with putty, or a block of wood about  $1\frac{3}{8}$  inches thick and 1 inch larger than the post may be nailed over the tin roof and then covered with tin, which should be soldered to the roofing. The post may then be toe-nailed to this block. Angle posts are braced sufficiently by the railing without extending through the roof, but where intermediate posts are used it is best to carry them to the plate.

*Movable Floor.*—If the porch roof is to be used as a balcony it should be covered with tin or copper, and a movable flooring, made of slats and cleats, laid over it. The slats should be of 4-inch square-edged flooring, laid  $\frac{1}{4}$  inch apart and nailed to  $1\frac{3}{8}$ -inch or  $1\frac{3}{4}$ -inch cleats, which should be blocked up from the tin, but not fastened in any way. This flooring should be made in sections convenient for handling.

Although not a matter of construction, a very common mistake made in designing residence porches that face the South or West is that the bottom of the cornice is placed too high above

the floor, so that the roof does not protect from the sun during the afternoon.

Unless the porch is very deep the clear opening above the floor should not be more than 8 feet if the porch faces the West. On the east side of the house this is not a matter of consequence.

**127. Dormers.**—Dormers are of two kinds—those built entirely on the roof, as in Figs. 163-166, and those which form a continuation of the wall, as in Fig. 162.

On isolated or suburban residences the former are more common, although on story-and-a-half houses the latter are often used. Dormers of the latter kind are very common on the fronts of public

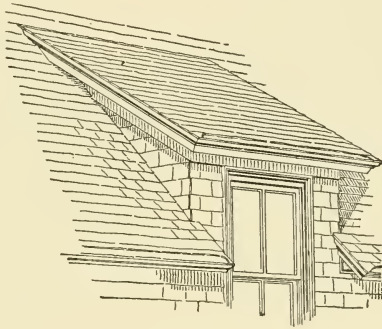

Fig. 162.

buildings and city residences, but they are usually built either of masonry or metal, and often with elaborate gables, pilasters, etc.

There are so many different styles of dormers, and so many different ways of roofing and finishing them, that it is impossible to much more than allude to them. As a rule, the eaves and roof are made to correspond with those of the building, except that where the eaves overhang the main roof there is no necessity for a gutter.

To be of practical utility the window sill should be not more than  $2\frac{1}{2}$  feet, nor the top of the window less than  $5\frac{1}{2}$  feet, above the floor.

A few examples of common types of dormers are shown in Figs. 162-166. The simplest method of roofing a dormer, when the main roof rises high enough, is that shown in Fig. 162. The roof of the dormer should have a pitch of at least  $30^\circ$ , and the outer edge should be provided with a gutter and conductor.

For dormers placed on the roof a gable or hip roof has generally the best appearance, and for these the style of finish shown in Fig. 163 is about the cheapest. On houses of the colonial type dormers similar to that shown in Fig. 164, or with a semicircular roof and gable, are often used, and frequently a single dormer of this type is placed between two of the type shown in Fig. 163. When the gable end is semicircular the roof is generally of the same shape and covered with tin or copper, but when the gable is finished as in Fig. 164, a pitch roof covered with slate or shingles is often used, the

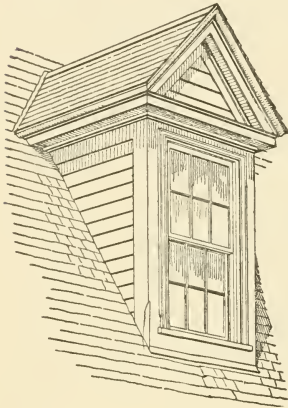

Fig. 163.

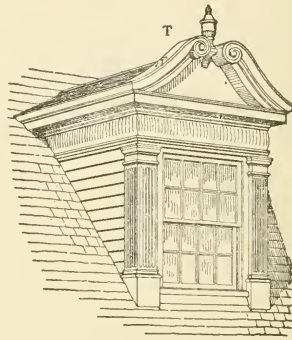

Fig. 164.

gable cornice being made about 10 or 12 inches wide on top and covered with tin or copper, as shown at *T*, and the roof dropped behind it, as with masonry walls.

Figs. 165 and 166 show types of dormers often used on shingled houses. These admit of a great variety of treatment.

Fig. 165 illustrates a style of shingled valleys that has become quite common on this style of building. The valleys, instead of being formed as described in Section 133, are rounded so that the courses of shingles may be made continuous from the main roof to the dormer. The juncture of the sides of the dormer with the main roof are also sometimes shingled in a similar manner.

The framing of the sides and roof of all of these dormers is very much the same, the description given in Section 82 applying to nearly all wooden dormers.

**128. Wooden Skylights.**—Large skylights, and those having a gable or hipped roof, can be made much better of galvanized iron or copper than of wood, but small skylights or glazed scuttles, when necessary for lighting an attic room, may be constructed of the latter material when not within the fire district.

Such skylights usually consist of a glazed sash through which light is admitted, and the frame on which the sash rests and to which it is usually hinged.

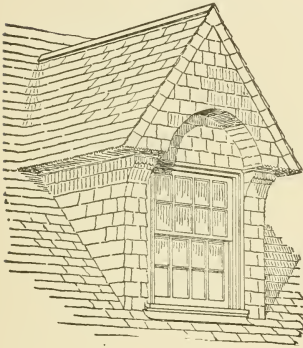

Fig. 165.

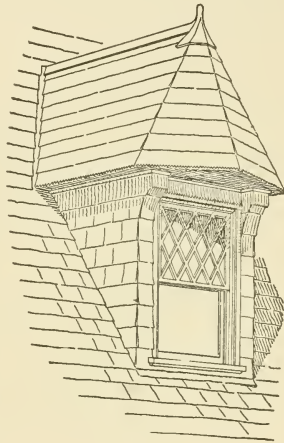

Fig. 166.

When on a pitched roof, the skylight or sash is usually placed parallel with and about 8 inches above the roof. The proper method of constructing such a skylight is shown in section in Fig. 167. An opening is first framed in the roof by means of header and trimmer rafters and the frame spiked to the inside of the opening. This frame should be made of 2-inch or 2½-inch plank 11½ inches wide. Quite often the frame is made of 6-inch or 8-inch rough plank nailed on top of the roof, the inside flush with the rough opening, and the opening and frame cased with finished boards or ceiling. This method, however, is not as good as the one shown, as the wide planks add to the stiffness of the frame and opening and prevent the two from separating.

The sash is framed together in the same way as window sash, but

should have no cross bars or muntins, and the lower rail should be made so that the glass will pass over it. The rails and stiles should be 2 inches wider than the thickness of the frame, and a  $\frac{3}{4}$ -inch strip should be nailed to the under side of the stiles, outside of the frame, to protect the joint.

For economy in the glass, and also to stiffen the sash, the latter is usually divided into lights, about 12 inches wide, by longitudinal muntins or sash bars, as shown in the isometric view. The glass is usually set in putty at the top and sides, but at the bottom the top

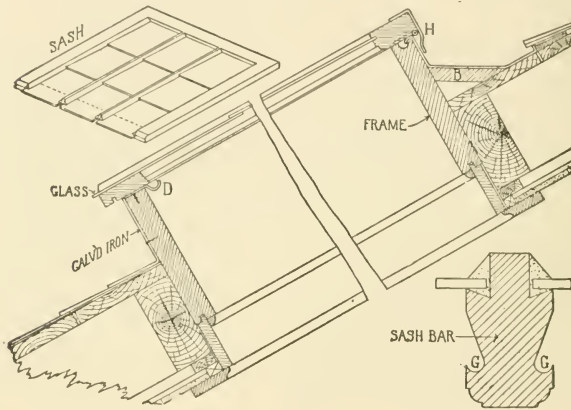

Fig. 167.

of the glass is left free to shed water. If the length of the sash is not more than 36 inches each light should be of one piece of glass. When it is greater than this the lights may be glazed with two or more pieces lapped over each other (about  $1\frac{1}{2}$  inches), as shown in the section.

Greenhouse roofs are glazed in this way, the divisions often being 8 or 10 feet long and glazed with small lights of glass. The thickness of the sash should not be less than  $1\frac{3}{4}$  inches, and if the frame opening is greater than 3x4 feet the thickness should be increased.

The most important items in connection with a skylight of the kind shown are the flashing and provision for taking care of the condensation that always forms on the under side of the glass, if the room below is warmed or occupied.



Behind the top of the frame a gutter should be formed as shown, the board *B* being cut so as to be highest at the middle and falling to each side. The lining of this gutter should extend well up on the roof, and should be turned over the edge of the frame into a groove which should be graded to drain off the water at the sides. If the sash is to open it should be hinged at the top and a strip of lead nailed to the top rail, as shown at *H*, to form a counter flashing. If the sash is stationary a simple fillet may be nailed to the under side of the sash above the frame. The sides of the frame should be

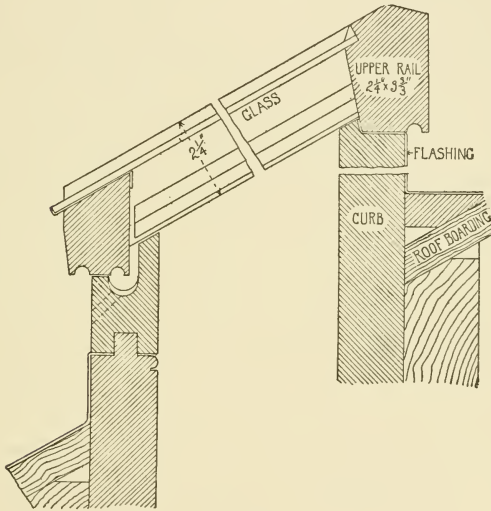

Fig 167a.

flushed with tin (or zinc) shingles the same as around a chimney, the flashing being carried to the top of the frame.

At the bottom of the frame it is better to use a wide piece of galvanized iron for the flashing, as this will stay in place better than tin or zinc.

For taking care of the water of condensation a small gutter should be formed in the flashing, as shown at *D*. As the water forms on the glass it runs down until it strikes the lower rail and then drops into the gutter.

For a small skylight the water in the gutter will evaporate so that it will not overflow, but on larger skylights provision should be made for draining off the water by means of a small pipe carried through the frame.

On large skylights, also, if made of wood, the sash bars should have a cross section like that shown by the enlarged section, gutters being formed at *G* to receive water that may run down on the sides of the bars. These gutters should empty into the gutter under the lower rail. Unless some such provision is made for receiving the condensation, much trouble will be experienced by water dripping on the floor.

The sash is usually fastened by a flat iron bar, provided with holes to slip over a pin, so as to both secure the window and to hold it open at certain distances. The frame and sash should be made of clear, well-seasoned cypress, white pine or redwood.

When a skylight of the style described above is placed on a flat roof it may be made in the same way, only making the frame higher at one end than at the other, so that the sash will have an inclination of about 2 inches to the foot. On flat roofs the frame or curb may be set on top of the roof.

Fig. 167*a* shows another detail, which is in some respects superior for large skylights.

*Scuttles* in a roof should have a frame and be flashed in the same way as described for skylights, and the corner should set down over the frame and be covered with tin or copper.

**129. Shingled Roofs.**—Shingles have always been the common roofing material of the United States, and probably will continue to be for a number of years. While shingles are inflammable and not as durable as tiles or slates, the better qualities are sufficiently durable for the ordinary residence, and they may be treated so as not to take fire easily. They are also admirably adapted to color treatment, by means of stains, and many architects prefer them to slate on residences for this reason. The low cost of a shingle roof, as compared with a slate or tile roof, however, is probably the chief factor in their selection.

The best shingles are considered to be those made from cypress, redwood or cedar, in the order mentioned. Cypress shingles are probably more durable than redwood shingles, but their advantage in durability is offset by the slow-burning qualities of redwood, and also by the richer color of the latter wood, so that there is not much choice between the two woods.

The most common wood for shingles, however, is the cedar, which is considerably cheaper than cypress or redwood, and sufficiently durable when dipped in oil or stain. The old-fashioned split pine shingles were very durable, but the pine shingles now sold are inferior to cedar. Spruce shingles are also sold in some localities, but are not suitable for good work.

Practically all of the shingles now used have rough surfaces as they come from the saw.

Cedar and redwood shingles as commonly sawn are 16 inches long, while cypress shingles are usually 18 inches long, and may, therefore, have a greater exposure to the weather. Redwood shingles and the cedar shingles from the States of Washington and Oregon (which furnish most of the shingles used west of the Mississippi) are  $\frac{5}{16}$  inch thick at the butt; cypress shingles are usually sawn thicker, those used in Boston being  $\frac{7}{16}$  inch and  $\frac{1}{2}$  inch thick.

Ordinary roofing shingles are of random widths, varying from 2 $\frac{1}{2}$  to 14 and sometimes 16 inches; they are put up in bundles, usually four to the thousand. A "thousand" common shingles means the equivalent of 1,000 shingles 4 inches wide.

When shingles are to be laid to form a pattern, it is desirable and often necessary that they shall all be of the same width. For this purpose shingles of certain widths are bunched together and sold as "*dimension shingles*." The most common width for dimension shingles is 6 inches, although 4-inch and 5-inch shingles are carried in stock in many localities.

Dimension shingles are generally of the best quality and cost a little more than random widths.

In most cities dimension shingles with the butt sawn to various patterns are also carried in stock. Any suitable pattern can, however, be sawn from dimension shingles at a small expense.

*Grading of Shingles.*—Shingles are variously graded and marked by the manufacturers, the grades and marks differing for the different woods and in different localities.

The best quality of shingles should be free from sap, shakes and knots. The Washington and Oregon cedar is almost entirely free from all of these defects. In pine and cypress shingles small sound knots are permitted when not nearer than 8 inches to the butt end.

Unless the architect is familiar with the markings of the shingles in the local market, it is best to specify "the best quality," rather than the "first quality," as the terms are not synonymous, the best

quality often being marked "Extra" or "Prime," while "first quality" may really be used to designate a quality not so good.

*Durability.*—In regard to the durability of shingles, an instance is on record where cypress shingles remained on the roof of a Virginia mansion, in a good state of preservation, for 104 years. Redwood shingles should remain in good condition for from 25 to 50 years, and if dipped in oil would probably last longer. Cedar shingles should last from 12 to 15 years with ordinary treatment, and if dipped in oil or creosote should last 25 years.

*Paper Lining.*—The roofs of all buildings that are to be plastered (at least in the Northern States) should be covered under the shingles by a layer of good strong waterproof paper. It is true that such a lining is apt to diminish the durability of the shingles (unless they are dipped all over) by causing them to sweat and rot on the under side, but this disadvantage is more than offset, in the Northern States, by the additional warmth obtained, and by preventing fine snow that may sift under the shingles from going farther.

Tarred felt has been much used for this purpose and answers very well, but there are waterproof papers which are more durable, as well as cleaner and better to handle.

**130. Laying the Shingles.**—Shingles are generally put on by the carpenter, although in the larger cities there are persons who make a specialty of shingling roofs; but it is doubtful if, as a rule, they do the work as well as a regular carpenter.

The men that put on the shingles also usually do all flashing, except counter flashing, and the flashing material is ordinarily furnished by the tinner.

In shingling a roof the workmen always commence at the eaves, or lowest edge, and lay the shingles in courses, either to a line or straight-edge. The first or lowest course should always be a double or triple one (usually double); the other courses are laid single. Each shingle should be secured by two 3-penny nails, driven about 8 inches from the butt, and if a very durable roof is desired galvanized nails should be used. (Cedar, cypress or redwood shingles will usually remain in good condition long after the nails have been destroyed by rust.)

The courses of shingles should lap over each other so that a little less than one-third of the length of the shingle will be exposed to the weather.

Unless the roof is very steep 16-inch shingles should not be laid more than  $4\frac{1}{2}$  inches "to the weather," nor 18-inch shingles more than  $5\frac{1}{2}$  inches to the weather.

Of course the more the shingles are laid to the weather the greater area a thousand shingles will cover, and hence it is to the contractor's advantage to lay them as much to the weather as he thinks is safe; for this reason the specifications should always state how much of the shingle is to be exposed.

The following table shows the area that 1,000 shingles (random widths) will cover when laid with different exposures, allowing nothing for waste:

Laid $4\frac{1}{4}$ inches to the weather, 1,000 will cover 118 sq. ft., or 847 to a "square."
" $4\frac{1}{2}$ " " " " " 125 " or 800 " "
" $4\frac{3}{4}$ " " " " " 131 " or 758 " "
" 5 " " " " " 138 " or 720 " "
" $5\frac{1}{2}$ " " " " " 152 " or 655 " "
" 6 " " " " " 166 " or 600 " "

This table, of course, applies to either walls or roof.

The shingles in the different courses should be laid so as to break joint at least 1 inch, and as much more as possible. They should

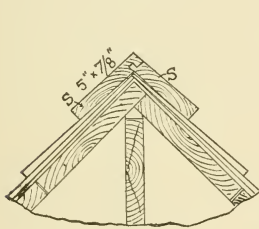

Fig. 168.

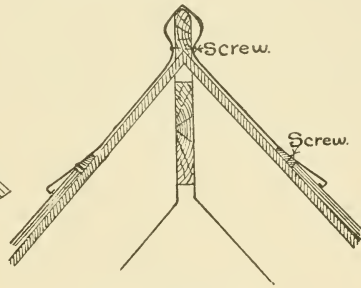

Fig. 169.—Ridge Cresting.

not be laid too tightly together, as this will make them bulge when they become wet.

**131. Ridges and Hips.**—The ridge of a shingle roof is commonly finished by sawing off the tops of the shingles and nailing two boards called *saddle boards* over them, as shown in Fig. 166, and in section in Fig. 168. If an ornamental cresting is desired it may be sawn out of a plank, set on edge, with the bottom edge formed to set *over* the saddle boards. In large cities it is quite a common custom to finish the ridge of suburban dwellings with a galvanized iron cresting, as shown in Fig. 169.

The *hips* of a shingle roof may be finished in three ways: *A*, by

means of a wooden or metal hip roll; *B*, by close shingling and flashing, and *C*, by shingling parallel with the hips.

In the first method wide shingles are selected for the hips, and they are cut off on the slant of the hip, a wooden moulding of the shape shown in Fig. 170*a*, or a metal hip roll, of the shape shown in Fig. 170*b*, being set over the joint. Wooden hip rolls may be worked

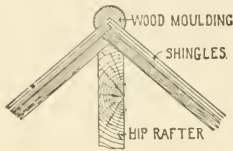
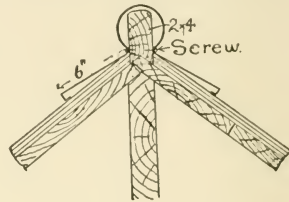
Fig. 170*a*.Fig. 170*b*.—Metal Hip Roll.

out of  $1\frac{3}{4}$  or  $2\frac{1}{4}$ -inch stock. They are often turned in ornamental patterns to represent tiles. When galvanized iron or copper hip rolls are used it is best to nail a wooden hip pole to the roof, under the metal roll, and the latter should be nailed to it. In a great deal of work, however, this wooden pole is omitted, the metal being simply nailed to the roof through the flanges.

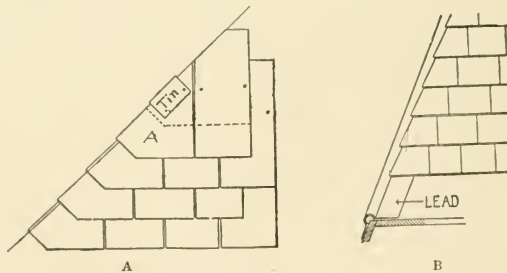

Fig. 171.

In making a close hip wide shingles should be selected and cut to a pattern, as shown at *A*, Fig. 171, and over each pair of hip shingles a piece of tin or zinc, 5x5 inches, bent to the proper angle, should be nailed, so that it will come just above the bottom of the next shingle. This tin makes the hip tight and prevents the shingles from splitting and being blown off. The edges of the hip shingles should be lapped

alternately over each other as shown. This makes a tight and very neat looking hip. On very steep roofs the shingles need not be cut at right angles to the hip, but the butts carried out straight, using the tin shingles as above.

A modification of this method, sometimes adopted, especially on spires, is to form the hips by a  $1\frac{1}{4}$ -inch wood bead, nailed to the boarding on the line of the hip, and covered with long strips of tin or sheet lead, 10 inches wide, turned over the bead and spread out on the roof (as at B), the edges of the shingles being lapped over the flashing and laid close against the  $1\frac{1}{4}$ -inch bead. When care is taken to have the beads perfectly straight this makes a very pretty hip.

The third and cheapest method, sometimes called the "Boston

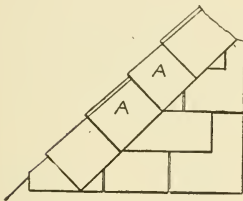

Fig. 172.

Hip," is to lay a course of 4 or 5-inch shingles parallel with the hip and over the other shingles, as shown in Fig. 172, the hip shingles lapping each other alternately, as shown at A, A. The hips and ridges of a roof are not very apt to leak, but unless the shingles are well secured they are liable to be blown off. With a hip roll it is easier to make the hips *straight* than by the other methods.

**132. Deck Mouldings.**—When a shingle roof terminates under a deck roof covered with tin or copper, the best method of finishing the edge of the deck roof is by means of a galvanized iron or copper moulding, extending on to the shingle roof as shown in Fig. 173, the tin or copper roofing being locked and soldered to the top of the moulding. A wooden crown moulding may be used in place of the metal moulding, the roofing extending over the top, but it does not make as good a job as the metal mould.

If a railing or cresting of any kind is to be put around the edge of a deck, or tinned roof, it should be secured to the roof by nailing blocks of wood of the proper size to receive the uprights *over* the tin or copper roofing, and then covering the blocks with tin or copper, soldered to the roofing. The uprights may then be screwed to the wooden blocks by brass screws.

The angle formed in a gambrel roof is generally finished as shown in Fig. 174, a small moulding being used, as it is not intended to be conspicuous.

**133. Flashings.**—If a good quality of shingles are used and or-

dinary care exercised in laying them, there should be no danger of a leak on a plane roof surface. The places where leaks most frequently occur, and with which especial pains should be taken, are those around chimneys, dormers or skylights, and in the valleys.

The only way in which these places can be made tight is by the use of *flashings*, *i. e.*, pieces of sheet tin, zinc, copper or lead.

For shingle roofs I. C. tin or 14-ounce zinc is generally used for flashings, and 3-pound or 4-pound sheet lead for counter flashings, although in much cheap work tin is used for the counter flashing.

The use of zinc for flashings appears to be confined to the Eastern States, where it is considered greatly superior to tin, and is very commonly used. The roofers in Colorado claim that in that State there is a certain amount of alkali in the rain water which eats away the zinc but does not affect tin. Whether this is true or not the author does not know, but no zinc is used there for flashings, and in general tin appears to be the common flashing material throughout the country. One of the best (stamped) brands of tin should be specified, and it will be more durable if painted on the under side before using.

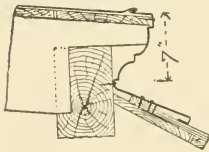

Fig. 173.

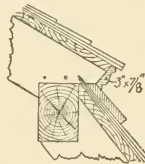

Fig. 174.



Fig. 175.

For slate roofs 16-ounce copper should be used, as it is much more durable than tin or zinc, but for shingle roofs it would hardly be in keeping.

For all counter flashings built or let into mason work sheet lead should always be specified.

For open valleys on large roofs the author has often used galvanized iron, frequently in the shape shown in Fig. 175, the ridge at the centre being formed to prevent the possibility of nails being driven through the iron by the workmen walking in the valley. Tin valleys are often punctured in that way.

*Valleys.*—There are two methods in common use of forming the valleys. The first, and the one most generally used with shingle roofs, is to line the valley with long strips of tin or zinc, laid the



whole length of the valley and locked and soldered together at the joints. The lining is then nailed to the roof boarding, at the edges, about every 12 inches.

The shingles are laid over the edges of the lining from 4 to 6 inches, leaving an *open* valley 6 or 8 inches wide, as at *A*, Fig. 176. On roofs having a pitch of 45 degrees or more the lining should be at least 18 inches wide, and on roofs of less pitch at least 20 inches wide.

The second method gives what is called a "close" valley. Trapezoidal pieces of tin or zinc are cut out, usually 15 inches at the top, 10 inches at the bottom, and 9 inches long for 16-inch shingles, and shingled into each course of shingles, the flashings being bent in the middle to extend up on each side of the valley, and the shingles laid close in to the valley, so that when completed the valley has the ap-

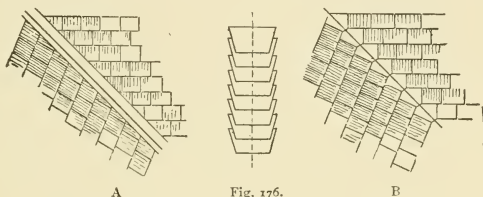

pearance shown at *B*. Close valleys look rather neater than open valleys, and on a steep roof they make tight work, but open valleys are the more common for shingle roofs, and when the pitch is less than 45 degrees are the safer to use.

Flashing against wooden dormers or any wooden wall should be done by working "tin shingles" about 7 inches square into each course; these "shingles" should be bent in the middle at right angles so that one half can be worked under the shingles on the roof and the other half under the shingles or siding on the wall, forming a sort of valley. If the pitch of the roof is less than 45 degrees the flashing should extend at least 4 inches on to the roof.\*

The best method of flashing under the dormer window sills, which is a bad place for leaks, was explained in Section 82.

#### 134. *Flashing Against Brick or Stone Work.*—Flashing against

\*The common size of tin shingles for flashing is 5x7 inches, the shingles being laid lengthways on the roof and turned up  $2\frac{1}{2}$  inches. This is the smallest size that should be used, and in exposed places or on rather flat roofs they should be larger, say 7x7 inches, or  $7 \times 7\frac{1}{2}$  inches, so that they may be cut from a sheet of 24x28-inch tin without waste.

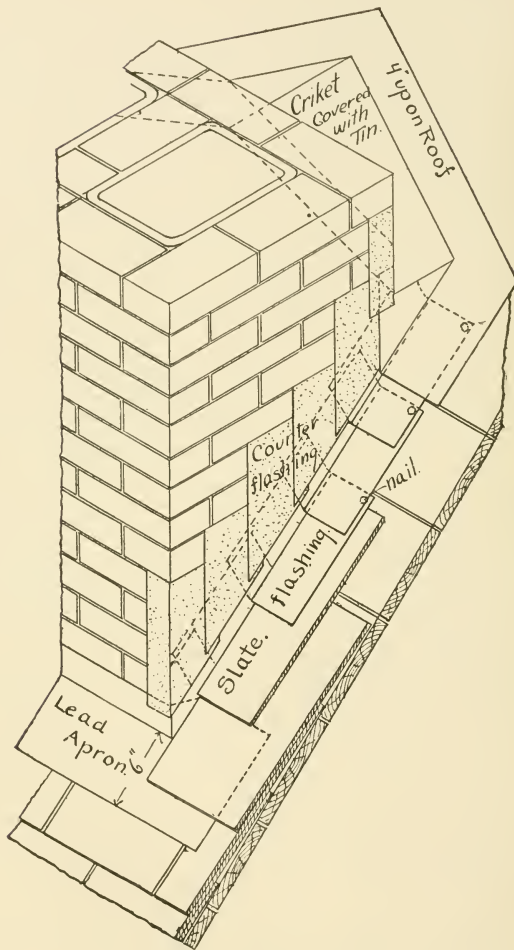

Fig. 177.—Flashing of Chimney.

chimneys, or where the roof abuts against any brick or stone wall is done in the same manner as against wooden walls, except that the flashings should be not less than 7 inches wide, and they should be covered by "*counter flashings*."

These counter flashings consist of pieces of metal, preferably 3 or 4-pound sheet lead, wedged or built into the joints of the mason work and turned down *over* the flashings. They should be placed at least 6 inches above the roof, and in places where snow is likely to lodge correspondingly higher. It is much better to build the counter flashings into the joints of the mason work as the latter is laid, as the flashings are more securely held and a tighter joint can be made. When not built in, the joint should be raked out and the counter flashings inserted and wedged with metal, and the joint tightly pointed with elastic cement. The bottom of the counter flashing should be not more than 1 inch above the roof.

Behind the chimney a "cricket" or  $\Lambda$  should be built and covered with metal to prevent snow and water from lodging there. Fig. 177 shows a portion of a chimney flashed in the method above described, which is the same for either shingles or slates.

Back of towers, or any place where snow is liable to collect, the flashing should be carried high enough both on the roof and wall that the water from the melting snow will not rise above it, and the joints should be locked and soldered like an open valley.

Where a shingle roof comes against a stone or brick gable wall, finished with a stone or terra cotta coping, the bottom of the coping should be kept at least 4 inches above the shingles, and the flashing should extend to within  $\frac{1}{2}$  inch of the coping. The counter flashing should be laid in the joint before the coping is set, and the coping should project over it.

Where there is a large stone, as a kneeler, or finial, a groove should be cut in the back of the stone, on a line with the bottom of the coping, and the counter flashing wedged into the groove and pointed with elastic cement. Such places on large roofs are frequently a source of trouble, and the flashing and counter flashing should be done with the greatest care.

The curbs of skylights and all parts rising from or coming against the roof should be carefully flashed. If the young architect wishes to establish a reputation for tight roofs he must be very particular to specify suitable flashing and counter flashing, and of ample width, as the builder will not be likely to put in more than is required.

**135. Tin Roofs.**—It is not the purpose of the author in this part to describe other methods of roofing than by shingles, as he proposes to treat the subject, which is an important one, in another volume, but as porch roofs are very commonly covered with tin, a short description of such roofs may be serviceable here.

Before applying the tin all uneven edges of the boarding should be smoothed off and the boarding covered with at least one thickness of sheathing paper or dry (not tarred) felt, more to form a cushion than for any other purpose. If there are knot holes in the boarding they should be covered with pieces of heavy galvanized iron. The tin should be of one of the best brands (only those which have the trade mark stamped on each sheet should be used) and should be painted on the under side before laying.

*Laying.*—When tin is laid on a flat roof it is customary to use "flat seams," that is the four edges of the tin sheets are turned over so as to lock together, as shown in Fig. 178, and after fastening to the roof the seams are pounded flat and soldered, thus making one large sheet of tin covering the roof. Occasionally a double-lock seam is used, but for ordinary purposes the single lock shown is sufficient. The tin is usually laid in courses across the roof, using

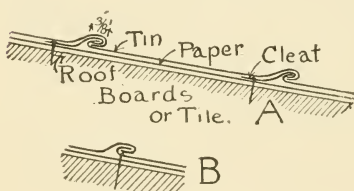

Fig. 178.

20x28-inch sheets, the side seams being made first, and the next course is locked to the one below it. Each course should be fastened to the roof at the top, the common method of fastening being to nail the sheets to the roof by short wire nails

driven under the turned-over edge of the tin as shown at *B*.

This method of fastening, however, is objectionable, from the fact that it causes the tin to form in waves as it expands, and there is also some danger of the tin, when expanding, drawing the nails. A better method of fastening the sheets to the roof is by means of strips of tin about  $1\frac{1}{2} \times 4$  inches, called "cleats." These cleats are locked over the upper edge of the sheet about every 14 inches and then nailed to the roof, as shown at *A*; when the next sheet (above) is laid the cleat is concealed. These cleats permit the roofing to expand and rise some without straining the tin or drawing the nails, and are recommended for good work. For very large roofs, however, provision for expansion should be made by standing seams, but

as these are not common on residences, except occasionally on pitch roofs, we will not describe them here.

After the sheets are all laid the seams are pounded down with a wooden mallet and all the joints well soldered. For soldering only rosin should be used as a flux, as acid, which is easier to use, is liable to destroy the tin. Before the roof is painted all rosin should be wiped or scraped off. The outer edges of the tin roofing should be turned over the upper edge of the wooden cornice and nailed about every 2 or 3 inches, or if it connects with a metal gutter the two should be locked and soldered together. Whenever a tin roof abuts against a wall or chimney the tin should be turned up a sufficient distance to prevent water from rising over it (at least 4 inches), and against a brick wall it should be counter flashed with sheet lead, as described in Section 134. When against wooden walls the roofing should be turned up against the boarding and the siding or shingles laid over it. The tin should also be turned up against all balcony posts (see Section 126) and the edges at the angles well soldered.

All tin roofs should be painted within a few days after they are laid, either with red lead in linseed oil or a good asphaltum paint.

A tin or copper roof should never be used as a floor without covering with a movable floor made of slats, as described in Section 126.

Copper roofs are laid in the same way as tin roofs, and the above remarks apply as well to copper as to tin, except that it is not customary to paint copper roofing.

**136. Superintendence.**—The superintendence of the various details of wooden construction described in this chapter is ordinarily quite a simple matter, although the work should be carefully inspected every two or three days to see that the material is of the quality specified and that the work is being executed according to the full-size details. The superintendent should see that where look-out or furring blocks are required they are not spaced too far apart and are well nailed, and that the finish is properly secured. He should also see that the various members are put together so that the joints will not be exposed to the weather, and wherever a particularly tight joint is required, that the parts are painted with white lead, slightly thinned with linseed oil. It is better to use white lead and screws for all work exposed to the weather than glue. It is also important to see that the shingles or clapboards are thoroughly nailed. It is not uncommon for shingles to be blown from the roof for lack of proper nailing. It will also be well to measure the ex-

posure of the shingles to see that it corresponds with the specifications.

Where gutters are formed for lining with tin, the superintendent should not forget to see that the bottom of the gutter has a sufficient fall and in the right direction. If the position of the conductors is not indicated on the drawings he should locate them before the gutters are formed. He should be sure that the kind of sheathing paper specified is put on the walls and roof, and properly lapped, and that a tight joint is made around all windows.

The portion of the outside work that will require the closest inspection is that of the metal work and flashing. Many builders and metal workers are so used to doing a certain grade of work that when anything better is specified they are apt to overlook it, if given a chance, and to go ahead in the usual way. As a general thing the cheapest tin, the lightest galvanized iron and the least of it that will possibly answer, is used where the contractors have their own way, so that the specifications should always provide for a particular brand of tin, one that is stamped on every sheet, and for a certain thickness (gauge number) of galvanized iron, and it is the duty of the superintendent to see that these are supplied. He should also be careful to see that the tin or iron is painted on the under side before putting in place, that the metal is of the width specified or shown by the drawings, particularly in the valleys, and that all joints are well soldered.

The flashing is a point that requires the closest scrutiny, as if this is poorly done there will be great danger of leaks, and a leaky roof will injure the architect's reputation and be a source of great annoyance. In some parts of the country the counter flashing around the chimneys, or where a roof joins a brick or stone wall, is often omitted, or, if done at all, is done with tin and in a very slovenly way. It is always safest and best to specify lead counter flashings, and that they shall be built in, as then there is little chance for a poor job. The flashings behind the chimney are also often left perfectly level, which causes the tin to rust and often to leak. Wide chimneys should always have a cricket behind them, and narrow ones should have the flashing pitched at least an inch to one side. Another common fault in flashing is that the tin shingles are not cut large enough, and hence can only be turned up against the chimney or wall about 2 inches. For this reason it is best to specify the size of the tin shingles that are to be used. (See foot note, p. 197.)

When counter flashing is put in after the walls are built, the superintendent should see that it is firmly wedged into the joints and that

the latter are pointed with cement. The flashing against gable walls that extend above the roof (see Section 134), should be given especial attention, as these places are even more apt to leak than around the chimneys. If the architect wishes to be sure that he will have no trouble with leaks, he must not pass the flashing by with a glance, but examine it carefully and in all parts, as a single defect may cause a great amount of trouble.

On large roofs, or roofs that are much cut up, the superintendent should caution the workmen about leaving shingle nails in the gutters and valleys, as they are frequently the source of leaks through workmen stepping on them and pushing them through the tin or copper. This danger appears to be greater on large roofs than on small ones.

With a tin roof the points that will need to be watched are the quality of the tin, the fastening to the roof, and that acid is not used for a flux in soldering. Many of these points seem trivial, and the inexperienced architect is apt to think that the builder will look after them for his own reputation, while he (the architect) is more interested in the ornamental part of the work, and in seeing how it "is coming out." While there are builders who care for their reputation, there are also a great many who appear to think that anything that will pass is good enough, and who, if they do not willfully slight the work, are very careless, to say the least, and, as the owner looks to the architect to see that the work is well done, the latter will find that it is for his own interest to inspect every portion of the work very carefully and see that everything is carried out as specified, even if the builder does say that he is "too particular," and that "it is all nonsense."

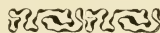

## CHAPTER V.

### INTERIOR WOODWORK.

---

#### ROUGH WORK, DOORS, STANDING FINISH, FLOORS, STAIRS.

The under floors are generally laid as soon as the joists are in place and bridged, and all bearing partitions are set at the same time, at least enough to support the floor timbers, but all other rough interior woodwork is usually left until the building is enclosed and protected from the weather.

**137. Under Floors.**—In some sections of the country it is customary to lay a rough under floor in every building having wooden floors, while in other sections under floors are seldom seen except in the very best buildings. The saving in omitting the under floor, however, is usually very slight, while the benefits to the building in having it are considerable. In the first place an under floor, especially if laid diagonally, greatly stiffens the building during the construction, and it is not only a great convenience to the workmen, but also allows the laying of the upper floor to be put off until the building is nearly finished. Moreover, without an under floor it is impossible to have any efficient deafening unless boards are cut in between the joists. For these reasons it is advisable to specify under flooring wherever the limit of cost will permit, even if some ornamentation has to be omitted.

The cheapest kind of lumber may be used (hemlock is generally used in the Eastern and Northern States and native pine in the Western States) so long as it is sound, but the boards should be dressed one side to a uniform thickness, and the narrower they are the better. In the better class of buildings the boards should be laid diagonally with the joists, pieces of scantling being cut between the joists at the walls to support the ends of the boards. It costs a little more to lay under flooring in this way on account of the waste at the ends, but it greatly stiffens the building and gives a much smoother surface to the upper floor, especially when the flooring is matched. The boards should be laid close together, nailed over every bearing with two 8-penny nails, driven through the top, and should extend



close to the brick walls or to the outside boarding of a wooden house, and should be cut around the studding.

*Preparations for Tile Floors.*—When a tile or mosaic floor is to be laid on wooden beams it is necessary to have a good bed of concrete under the tiles, and to support the concrete rough boards are cut in between the floor beams, resting on  $\frac{3}{8}$ -inch strips nailed to the sides of the beams. The top of the boards should be at least 4 inches below the top of the tiling, and 5 inches is better. The top of the beams should also be beveled on both sides to an edge at the centre. When wooden walls or partitions are to have a tile wainscoting it is customary to lath with expanded metal or some other form of stiff metal lath, and to hold the lath pieces of 2x3 or 2x4-inch scantling should be nailed horizontally between the studding and about 12 inches on centres.

**138. Deafening of Floors.**—In nearly all inhabited buildings it is desirable to prevent the conduction of sounds from one room to

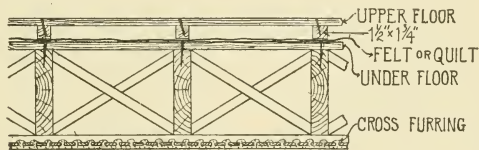

Fig. 178.

another through the floors or walls, and in school houses, office buildings and apartment houses sound-proof construction should be considered as necessary. The usual method of attempting to prevent the passage of sound through the floors is by lining the floors with some material that is expected to absorb and dissipate the sound waves. As commonly practiced, however, this method is usually only partially successful, owing partly to the failure of the lining to fully accomplish its object, but more to the solid connection maintained between the floor and ceiling by means of the *nails* and joists.

The author is of the opinion that perfect insulation from sound waves can be obtained only when the upper floor and the ceiling beneath have no direct connection by rigid bodies, either by contact or by nailing.

The most effective sound-proof construction is undoubtedly that described in Section 63, where two sets of joists are used. Owing to the great danger of such construction in case of fire, however, it is

not to be recommended except in rare instances, and then only when the ceiling is fireproofed, and all communication with vertical air spaces cut off.

The next most effective wooden construction, in the opinion of the author, is that in which the upper and under flooring is separated by an efficient deafening material, and in which *no nails* connect the two. Such a construction is shown in Fig. 178, the cleats to which the upper flooring is laid being merely laid on top of the deafening and not nailed. This could be further improved by filling the space between the cleats with mineral wool, and by a layer of mineral wool 1 or 2 inches thick on top of the lathing.

As already stated, however, the common custom is to merely lay a thickness of deafening material between the upper and under flooring, and nail the upper flooring through it and the under floor into the joists, and while this method is not perfect, if a good deafener is used it partially accomplishes its object.

**139. Deafening Materials.**—At this point it is deemed best to describe the more common materials used for deafening, *i. e.*, for absorbing and dissipating the sound waves. Most of these materials



Fig. 179.

are of the nature of paper felts, while some resemble carpet lining. All of these are put up in rolls or bales, usually 3 feet wide and containing 500 square feet.

*Cabot's Sheathing Quilt.*—This consists of a felted matting of eel-grass held in place between two layers of strong manilla paper by quilting, its appearance being as shown in Fig. 179. "The long, flat fibres of eel-grass cross each other at every angle and form within each layer of quilt innumerable minute dead-air spaces, making a soft, elastic cushion, which gives the most perfect conditions for non-conduction." Eel-grass was chosen for the filling because of its long, flat fibre, which makes it especially adapted for felting, and also because of its great durability,\* its resistance to fire, and because, owing to the large percentage of iodine which it contains, it is repellent to rats and vermin.

This quilt is made in single and double ply, each being put up in bales of 500 square feet, and costing in Boston \$4.50 and \$5.50 per bale, respectively. It is also now made with a covering of asbestos,

\* A sample of eel-grass 250 years old, and in a perfect state of preservation, may be seen at Mr. Cabot's office.

thus rendering it thoroughly fireproof. To obtain the best results in floor deafening the double-ply should be used, and in the manner shown in Fig. 178, the floor *floating*, as it were, upon the quilt. The material is also very efficient for heat insulation, and when used for this purpose there is no objection to the nails passing through it.

*Felt Papers.*—There are a great many felt papers made for lining floors, and a few are made fireproof by means of chemicals. As a rule these felts are cheaper than Cabot's "Quilt" (although the saving in an ordinary residence would be but little), and even among the felts there is quite a difference in cost. In choosing a felt paper for lining the architect should select one that is soft and elastic, so as to form a cushion, and the thicker the felt, provided it has the above qualities, the greater will be its non-conduction. The conducting property of a hard vibrant substance, however, is but little affected by its thickness. Some felts are made waterproof by having an asphalt centre, which is an advantage in case of fire or leaks, but it is

doubtful if such felts obstruct the passage of sound as well as felts without the asphalt centre.

*Bird's Florian Fireproof Paper.*—This is a deafening felt made by the manufacturers of the "Neponset" waterproof sheathing papers, which the author believes to be a very good article.

The material itself is rather hard and thin, but it is pressed in such a way as to form small indentations or air cells, as shown in Fig. 180, which make it elastic

and break up the sound waves. The fact that it is also non-combustible makes it of especial value where absolute non-conduction of sound is not necessary. The cost of this material in Boston is about \$2.28 per 500 square feet.

*Asbestos Sheathing.*—Sheathing papers or building felts made of asbestos are used to some extent for floor lining and for covering the outside walls of wooden buildings, principally on account of their fireproof quality. The best known of asbestos building papers are those made by the H. W. Johns Manufacturing Co. This company makes three thicknesses of asbestos building felt—thin, medium and

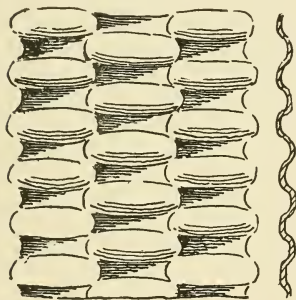

Fig. 180.

heavy—and for floor lining only the heavy or two layers of the medium should be used, two layers probably being better than one heavy layer. Asbestos felt would appear to have about the same effect in retarding the passage of sound waves as other felt papers of the same thickness, while in dwellings its fireproof quality is a decided advantage; it is also waterproof, and rats and vermin do not attack it. Asbestos felt naturally costs more than wood or paper felts, the cost of John's heavy felt being about 42 cents per 100 square feet, and of the medium 30 cents.

**140. Mineral Wool.**—There are at least two kinds of mineral wool made in this country. The more common kind is made by converting the slag of blast furnaces (the best being from slag that does not contain iron), mixed with certain rocks while in a melted condition, to a fibrous state.

Its appearance is much like that of wool, being soft and fibrous, but in no other respect are the materials alike. Mineral wool made from slag appears in a variety of colors, principally white, but often yellow or gray, and occasionally quite dark. The color, however, is said to be no indication of the quality, as all of the peculiar properties of the material are present in equal proportions in any of the shades. The other kind of mineral wool is known as *rock wool*, and is made from granite rock raised to 3,000 degrees of temperature. It is claimed to be absolutely free from sulphur and the only odorless wool manufactured; it has been approved by the U. S. War Department. Its color is white and its general appearance is the same as that made from slag. The peculiar nature of both kinds is that of a mass of very fine, pliant, but inelastic, vitreous fibres interlacing each other in every direction and forming an innumerable number of minute air cells. Its great value in the insulation and protection of buildings lies in the number of air cells which it contains, combined with its resistance to heat or fire. In common slag wool 92 per cent. of the volume consists of air held in minute cells, while in the best grade the proportion of air reaches as high as 96 per cent. This confined air makes it one of the best, if not the best, of the non-conductors of heat, and to a less degree of sound. Aside from these qualities it is very durable, contains nothing that can decay or become musty and is almost a sure protection against rats and vermin. Being itself incombustible it greatly retards the burning of wooden floors or partitions which have the spaces filled with it. The greatest value of this material is as an insulator of heat, but it is also a valuable non-conductor of sound. In the opinion of the author,

however, it can be considered only as a "muffler" of the sound waves, as he can think of no practical way in which it can be used so as to entirely *separate* the floor and ceiling, as it would be crushed by laying the floor cleats upon it. As a muffler or filling between the beams, however, there is probably nothing that is superior. As previously stated, the author considers that the most complete insulation from sound (without separate beams) would be obtained by floating the flooring on Cabot's Quilt or a very thick felt, with the spaces between the floor cleats filled with mineral wool.

Mineral wool, when used alone as floor deafening, may be laid on boards cut in between the joists, or on top of sheathing lath when that is used. The thickness of the wool should be at least 2 inches. Mineral wool is particularly desirable for filling the spaces between the studding of outside walls and partitions and between the rafters of the roof. It may be used to great advantage in partitions around bathrooms or water closets, and around water pipes when placed in partitions. In outside walls and attic roofs, as a protection from the heat of summer or the cold of winter, it is of the greatest value. By lathing the under side of the rafters with sheathing lath, and filling on top with 2 or 3 inches of mineral or rock wool, the comfort of the room below will be greatly increased. Flat roofs over inhabited rooms may be covered with rough boards and  $1\frac{3}{4}$ -inch cleats nailed on top, as in Fig. 178, and the spaces filled with wool, and the roof sheathing then nailed to the cleats. This would not only greatly increase the comfort of the rooms, but greatly retard the progress of fire from the outside. (When insulating against heat, nails driven through the insulating material do no harm.) When using mineral wool in floors it should be packed in closely, but not jammed so as to break the fibres, which are naturally very brittle. In partitions it is packed between the lathing, so as to fill the space completely, the wool being put in after the lathing has reached a height of 2 or 3 feet, then more laths put on, the space filled, and so on to the top; it should not be dropped from any considerable height, for the breaking up of the fibres destroys the insulating qualities of the material. In fact the tendency of mineral wool to settle and consolidate is the only drawback, except cost, to its use for insulation. The wool behind the lathing will not prevent the plaster from keying.

Mineral wool is sold by the pound, and in estimating the quantity of wool required, 1 pound per square foot of filling, 1 inch thick, should be allowed for ordinary wool and  $\frac{3}{4}$  pound for selected wool. The price of the ordinary wool is about \$1.25 per hundred pounds, and of selected wool \$2.

**141. Fire and Mice Stops.**—In every good residence provision should be made for preventing mice from going through the spaces between the studding and between the floor joists, and much may be done with a very little additional expense to prevent the rapid destruction of the building in case of fire.

Any material that will stop the progress of fire will also stop the passage of mice, but provisions may be made for stopping mice that are not sufficient to stop fire.

When mice stops alone are to be provided, tin will be found the most convenient material, and it should be used so that it will be absolutely impossible for mice to ascend from the cellar into the outside walls or into the partitions, and the second story walls and partitions should be protected in the same way. If the building has an under floor the boards should be extended close against the outside sheathing of a wooden building and against the walls of a brick or stone building, and carefully cut around all studding. If there is no under floor the finished flooring (if laid before plastering) should be extended in the same way. The space between the outside studding and between the sheathing and plaster should then be covered with tin, turned up 1 inch against the studs and sheathing and tacked, and every space, no matter how small, must be protected in this way or else solidly filled with brick and mortar or with mineral wool.

If the partitions are set on top of the flooring, a strip of tin 2 inches wider than the sole piece should be laid under it, as shown in Fig. 61.

If the studding rests on top of a partition cap below, a strip of tin may be laid between the studs on top of the under floor and turned up 1 inch against them. A better precaution, however, is to fill between the studding on top of the partition cap with five or six courses of salmon brick and mortar, as shown in Figs. 59 and 60, as this also forms an efficient fire stop. Where the chimneys are furred, or studded around, the space from the chimney to the back of the lathing should be closed with tin or brickwork. On brick walls that are furred by strapping, the easiest way to form a stop is to plaster between the strapping and flush with it for a distance of 10 or 12 inches just above and below the floor joists.

In localities where salmon bricks can be bought for \$4 or \$5 a thousand it will be about as cheap to fill the spaces between the studding with bricks and mortar as with tin. If asbestos sheathing is used as a lining between the flooring it may be fitted around the studding in place of the tin, but should be turned up against the

sheathing and studding and tacked. When the owner is willing to go to the expense, it will be much better to fill the spaces between the studding, both in walls and partitions, the entire height with mineral wool, and thus gain the advantage of sound and heat insulation and slow combustion, as well as stopping mice.

If the architect undertakes to provide mice stops at all he should see that the work is done thoroughly, as mice can go through a very small hole, and if a few holes are left the work done will be almost useless.

*Fire stops* have been described in Section 71, but the work is generally done after the building is roofed in and while the carpenter is getting ready for the lathers. If the walls and partitions are fire stopped it is best to complete the work by laying a fireproof or incombustible lining between the flooring, as described in Section 138.

The work described in the last four sections will not add to the appearance of the building, and to see that it is thoroughly done will require close inspection, but when faithfully carried out it greatly enhances the value of the building as a place to live in, as well as adding to its security, and may possibly save a great loss from fire. It is in many points such as these, that are not apparent from a casual inspection, that architects' houses usually are, and always should be, superior to those of the speculative builder.

**142. Back Plastering.**—This term is commonly used to designate plastering that is applied between the studding or rafters to make the building warmer and to keep out the wind. Before the introduction of the present high grades of sheathing papers, back plastering was quite common in the better class of dwellings in the Northern States, but it is now used to a much less extent, as the same object can be more cheaply, and the author believes more efficiently, attained by means of high-grade sheathing papers or Cabot's Quilt.

On the sloping roofs of attic rooms, however, it may be used with much advantage in conjunction with the sheathing paper, and even on the walls it will add much to the comfort of a frame dwelling if properly applied.

Where ordinary sheathing is used to cover the frame and rafters, back plastering should be applied by nailing two vertical rows of laths in each space between the studding or rafters, to the inside of the sheathing, and then lathing horizontally on these strips and plastering one heavy coat of haired mortar in the usual manner. In lathing between rafters 20 inches on centres, three rows of vertical laths

should be used. The plastering should be applied so as to come well on to the rafters or studding, leaving no spaces that are not protected.

**143. Byrkit's Patent Sheathing Lath.**—If back plastering of the walls or roof are contemplated it is better, and fully as cheap in many localities, to use the Byrkit Patent Sheathing Lath for the outside sheathing, placing the keys on the inside, and the plastering can then be applied directly to the sheathing. This sheathing lath, a full-size section of which is shown in Fig. 181, has now been in use for about ten years and is highly endorsed by architects who have used it. It is made by special machinery from pine, hemlock, cypress and spruce sheathing in random lengths and in 4, 6 and 8 inch widths, the 4-inch being the best to use, as it affords less opportunity for shrinkage and buckling.

The strips are tongued and grooved so that when put together they form a solid surface. Machines for making this lath have been placed in over 250 mills, principally in the Northwestern States and

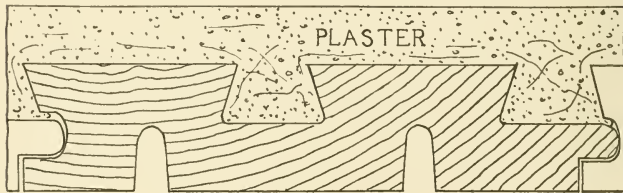

Fig. 181.

along the Mississippi River, and it is carried in stock in all the larger cities of those sections of the country. As it is very light (weighing only about  $1\frac{1}{4}$  pounds per square foot), it may be sent a long distance at a small charge for freight.

The cost at the mills varies from \$8 to \$12 per thousand feet, according to the locality, and when in the building the cost should not exceed 15 cents per square yard, including nails and labor. The principal use of this lath appears to be on the outside walls of frame buildings, the lath being applied to the *inside* of the studding in place of the ordinary wood laths and the sheathing on the outside of the studding being omitted, siding only being used on the outside. This construction, while greatly superior to common laths without sheathing, cannot be recommended except for summer cottages and a very cheap class of buildings, unless it be in comparatively mild climates.



This lath, however, is intended for use in place of ordinary laths *wherever* the latter are commonly used, as on walls, ceilings and partitions, and can be used to advantage in places where ordinary lath cannot be used without furring or in construction for which the latter is not suitable. Besides its use for back plastering it may be used for an under floor, where an open beam ceiling is desired, for sheathing outside walls to be finished with "rough cast" and for making solid partitions of short lengths (as between closets), by nailing back to back, horizontally and diagonally, and clinching the nails. Such a partition would be very slow burning. When used on sliding door

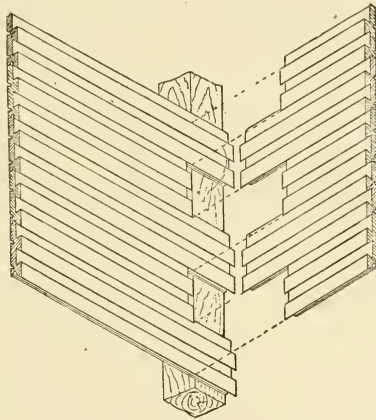

Fig. 182.

partitions there is no necessity for lining the pockets, as, being tight, nothing can get into the pocket. In fact there are many places about the average building where this lath might well be used, even if not used for lathing throughout.

From information furnished the author by architects who have used this lath, it appears to answer all of the purposes of the ordinary lath, besides making the partitions much stronger and increasing the stiffness or rigidity of a frame building, and under an attic roof or on outside walls it keeps out more cold than the ordinary lath and plaster. The plastering will not come off, and cracks no

more than on ordinary wooden laths, and a less quantity is required for covering a given surface. To obtain the best results for inside work 4-inch lath should be used, interlocked at all angles as in Fig. 182, and the plastering should be three-coat work, the scratch coat being allowed to dry out before the brown coat is applied.

For unsupported partitions of wide span the lath may be put on diagonally from the supports to the centre, thus materially relieving the centre of the beams under the partition and diminishing the tendency to sag.

This lathing should be included in the carpenter's specifications on account of the tools, etc., required in putting it on.

**144. Furring.**—This term is commonly used to designate work that is built out from the constructive members to receive lathing or metal work and sometimes sheathing or finished woodwork. It is

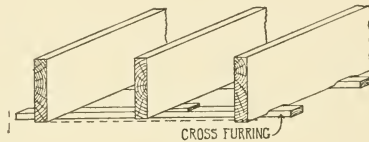

Fig. 183.

also sometimes called "false work," as the surfaces which it forms are hollow and do not indicate the actual construction.

In fireproof buildings all furring should be done in tile or metal, as described in Section 357, Part I., but in all other buildings the cheaper grades of wood are used for the furring and in small pieces, as they generally have to support nothing heavier than lath and plaster.

There is usually but little furring on the outside of buildings; the blocking for the cornice or belts and the furring for metal work or for curved roofs being about all that is generally required. On the inside, however, considerable furring is often required for the lathing in the way of strapping the walls and ceilings, furring out brick and stone walls, and in forming false beams, arches, coves, cornices, etc.

This inside furring is usually done immediately after the roofing is on and while the outside of the building (if of wood) is being finished.

For furring stock cheap grades of pine or spruce are used in the Northern and Western States, pine being preferable because it warps

and twists less. The stock may be rough, but where it is used for cross furring, etc., it is better to have it dressed to an even thickness, which adds but little to the cost.

*Cross-Furring of Ceilings.*—In many sections of the country it is the common custom to “cross-fur” the ceilings or under side of the floor joists with 2 or  $2\frac{1}{2} \times \frac{1}{3}$ -inch strips, as shown in Figs. 59 and 60, but this custom is not universal (see Sections 46 and 76), and if the floor beams were all dressed to a pattern there would not be much advantage in cross-furring. As it is, the principal advantage of cross-furring is that it is more practicable to get a level ceiling by it, and the floor beams may be spaced from 14 to 18 inches apart, while the bearings for the laths may be spaced either 12 or 16 inches, as desired, without much additional cost. Even if the bottom of the beams were all on a level when set, some will bend more than others, and, as the

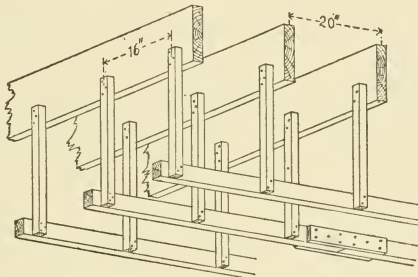

Fig. 184.

furring is put on some time after the beams are set, this unequal deflection may be in part overcome. On the other hand cross-furring leaves a space between the bottom of the floor joists and the laths sufficient for the passage of vermin and of fire.

When the ceiling is to be cross-furred no particular care is taken to have the floor joists level on the bottom, as any inequality may easily be overcome when putting on the furring strips. This is done by cutting the bottom of the beams that are lower than the average and blocking up those that are high, as shown in Fig. 183. In putting up the furring a strip is first put up at one side or at the centre of the ceiling and carefully leveled from end to end, and the other strips are all leveled from that by means of a long straight-edge and a carpenter's level. The usual size of the strips is 1x2 inches; if the joists or rafters are more than 18 inches apart the strips should be

1½x2 inches. In all first-class buildings the strips should be spaced 12 inches on centres, although 16 inches is the more common spacing because it is a little cheaper. The strips should be well nailed at every bearing with 10-penny nails (cut nails hold best). Where the under side of the roof forms the attic ceiling the rafters are cross-furred in the same way as the floor joists.

**145. Suspended Ceilings Under Flat Roofs.**—In the Eastern States the ceiling joists under a flat roof are seldom built into or supported by the walls, but are hung from the roof joists in the manner shown in Fig. 184, and carefully leveled as they are put up. It should be noticed that the ceiling joists run at right angles to the roof joists, and if the spacing of the former is different from that of the latter this is necessary. If the spacing of the two sets of joists is the same the ceiling joists may be hung directly beneath the roof joists, using 1x3-inch boards for the suspending pieces. The putting up of this work is generally specified under the head of furring.

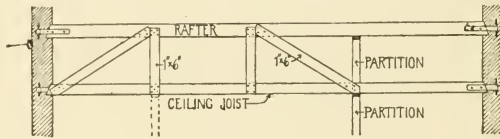

Fig. 185.

When the walls are of brick and the bricks are laid from an outside scaffolding this method of supporting the ceiling is possibly the most economical, but when the walls are laid from the inside, as is the custom in the Western States, the author believes that it is better to build the ceiling joists into the wall and tie them in the same way as the floor joists. Where the span is not greater than 13 feet, 2x6-inch joists will be stiff enough, but for greater spans it will be more economical to use 2x4-inch or 2x6-inch joists and truss them from the roof joists, as in Fig. 185. By trussing each pair of joists the roof may be made very stiff and with less timber than is required by the method shown in Fig. 184, and there is less "kindling wood" in the roof space.\* If the ceiling joists are anchored to the wall, as should be the case, they also greatly strengthen the building. Where the ceiling joists are built into the wall they are supported by the interior partitions and another set of studding placed on top of the cap to support the roof joists.

\* This trussing or bracing should be specified in connection with the roof framing.

The ceiling joists are also utilized by the brick masons for a scaffold, a temporary partition being set under them about 5 feet from the wall (as shown by the dotted lines) and allowed to remain until the joists are permanently braced. In frame buildings the ends of the ceiling joists may be supported by a false girt. Where the rooms under a flat roof are inhabited a space between the ceiling and the roof adds greatly to the comfort of the rooms, and it is desirable that the average height of this space should be at least 2 feet. This space also affords opportunity for running pipes and wires above the ceiling joists. Of course the greater the height of the air space the greater becomes the expense of suspending the ceiling. In Colorado suspended ceilings are seldom, if ever, seen.

The ceiling joists, whether suspended or built in, are usually cross-furred if the other ceilings are, although this is not really necessary with the suspended ceiling.

**146. Furring of Walls.**—Except in the dry climate of the Rocky Mountain region it is customary to furr all outside brick walls (that are not built hollow) with 1x2-inch strips, nailed to the walls vertically and set 12 or 16 inches on centres. These strips can generally be secured by nailing into the joints of the brickwork, using two nails close together if necessary. Very often thin strips of wood are built into the inside of the wall at intervals of 2 feet to form nailings for the furring. These strips, when used, should not be more than  $\frac{3}{8}$  of an inch thick, and their use is not desirable and should not be permitted in buildings over two stories in height. (See Section 255, Part I.) Where stone walls are to be furred or "strapped" it is necessary to "plug" the walls to form the nailings. This "plugging" is done by raking out the mortar and driving in wooden plugs about  $\frac{3}{8}$  inch in diameter and 4 or 5 inches long. The plugs should not be more than 2 feet apart in the length of the furring strips.

To plug a wall takes considerable time, and unless the walls are quite high it is usually about as cheap to set 2x4-inch studding inside of the wall, securing it to the floors at top and bottom, although this of course takes up a little more space than the "strapping."

Whichever method is pursued the furring should be put up plumb and true, so that the walls when lathed and plastered will form a true plane. Inside brick or stone walls are better not furred, as the furring necessarily leaves an air space which affords room for the passage of flames and vermin, and the plaster can be applied to brick or stonework as well as to lathing.

Where there are to be inside shutters it is often necessary to "fur

out" or thicken the wall to form the pockets. If this increase in thickness is 2 inches or more, the furring should be done by independent studding and should be particularly described in the specifications. All studding for furring should be bridged for stiffness and to keep it in place, as described in Section 69.

**147. Furring Around Chimneys.**—In the Eastern States it is customary to fur around all chimneys with 2x3-inch or 2x4-inch studding, usually set flatways (except in outside walls), as shown in Fig. 186. The object of this is to form a nailing for the base, chair rail or picture moulding, and also to prevent the cracks that are almost sure to occur where a wooden wall joins a brick one. The studding should be kept at least 1 inch from the brickwork, and should be set plumb, bridged at least once, and the angles made square. If the chimney comes in a brick wall it is also usually furred around in the same way.

Fig. 187 shows the way in which a chimney which it is desired to

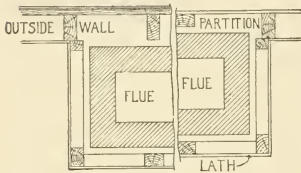

Fig. 186.

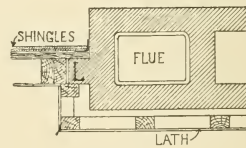

Fig. 187.

have project on the outside of a frame wall should be built; a 4-inch lug being carried up on each side of the chimney, as at *L*, and the boarding and wall covering extending over it. While this construction can easily be made tight, it weakens the wall very much by cutting the girts and plate, and should only be used with caution and not near an angle of the building.

When there is a fireplace the furring is set so as to form a breast wide enough to receive the mantel and an opening is left large enough to receive the facing around the fireplace opening, the facing being usually set flush with the plaster (see Fig. 169*a*, Part I.). Where there is a thimble for a stove pipe, a square opening should be framed in the studding opposite the opening, and at least 10 inches larger than the diameter of the pipe. The thimble is generally set so as to project  $\frac{1}{2}$  inch from the brickwork, and the back of the recess is plastered directly on the chimney, while the sides are cased with wood, as shown in Fig. 188. This recess has a bad appear-

ance, and a better way to do is to cover it with expanded or sheet metal lath, with a round hole for the thimble to pass through. A thimble 8 inches long can then be used and the breast plastered without a recess. The sides of the studding back of the plastering should also be covered with tin, so that there will be no danger from fire.

In some of the Western States furring around the chimneys is almost invariably omitted, and the author, after several years' experience with both methods, is of the opinion that, except against outside frame walls, it is better to use fire clay flue lining and then plaster directly on the brickwork. Where the chimney is furred it is difficult to completely stop the space at the floor levels, and if fire does occur it has a chance to make considerable headway before discovery. With flue lining, and the outside of the chimney plastered to the floor, there is no objection to nailing the base or other mouldings to the chimney, so that the only objection to this method is in the probability of cracks occurring in the angle with the woodwork. By building the chimney as shown in Fig. 189, and covering the flush side with metal lath, lapped on to the studding, there will not be much likelihood of cracks.

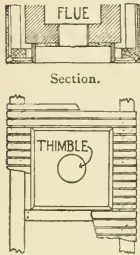

Fig. 188—Elevation.

If the chimney is to be wainscoted the wainscoting must be kept outside of the plaster. Where the chimneys are plastered the breasts for fireplaces must be carried up in brick, but in many localities this is fully as cheap as furring and lathing, and certainly more fireproof.

When rooms are to be finished in the attic the studding at the sides and the collar or ceiling beams (see Fig. 79) are usually specified under the head of furring, and, unless they are required to support the roof, are put up after the roof is completed.

*When rooms are to be finished in the attic the studding at the sides and the collar or ceiling beams (see Fig. 79) are usually specified under the head of furring, and, unless they are required to support the roof, are put up after the roof is completed.*

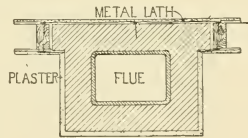

Fig. 189.

**148. Special Furring.**—Besides the usual cross-furring there is generally more or less special furring required in forming false beams, arches, cornices, coved ceilings, rounded corners, etc., and in preparing solid beams and posts for plastering.

Wherever a solid beam, post or lintel is to be plastered on wooden lath, the timber should be furred with strips at least  $\frac{3}{4}$  inch thick to

afford a clinch for the plaster, and on vertical surfaces these strips should always be put on so that the laths will be horizontal, as in Figs. 52 and 55. Where it is impracticable to use furring strips metal lath (such as expanded metal or the Bostwick lath) should be used, as in no case should wooden laths be nailed against a solid

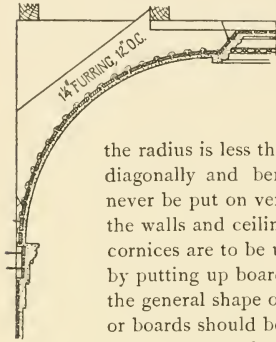

Fig. 190.

timber. Round corners in partitions should have the studs set not over 10 or 12 inches apart, and they should be bridged every 3 feet with solid bridging cut to the curvature of the corner. When the radius is less than 3 feet the laths are usually put on diagonally and bent around the corner. They should never be put on vertically. When the angles formed by the walls and ceiling are to be coved, or heavy plaster cornices are to be used, it is necessary to fur for the same by putting up boards cut to the shape of the cove or to the general shape of the cornice. These furring blocks or boards should be at least a full inch in thickness, and if very large, at least  $1\frac{1}{4}$  inches thick. They should also be set 12 inches on centres, as the close spacing makes a much better job of lathing and a firmer ground for receiving the plaster. For plaster cornices the blocks should be cut so as to require as little stucco work as possible (see Section 349, Part I.) and

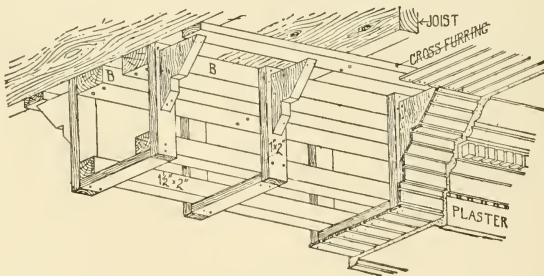

Fig. 191.

then lathed, as in Fig. 190. In forming false beams for plastering a skeleton is generally built, as shown in Fig. 191, which is suspended from planks *B, B*, spiked to the under side of the floor or ceiling



beams above, or to blocks let in between them. If the beams are quite shallow solid blocks of plank may be cut of the proper shape to receive the lathing and nailed to the under side of the joists or to the cross-furring. Where the depth of the beam is 12 inches or more, however, the construction shown in Fig. 191 is much the best. If the beams are to be cased with wood solid blocking is generally employed for furring, as shown in Fig. 283.

False arches are usually formed in a similiar manner, except that the vertical pieces, being longer, should be  $1\frac{3}{4}$  inches thick, and a curved rib should be cut to form the edge of the soffit and to receive the laths, as in Fig. 192.

The essential points in regard to all furring are that it shall be strongly secured and be put up *perfectly straight and true*. This is of especial importance in connection with beams and cornices, as any

irregularity can not well be overcome in the plastering, and the least deflection is readily discovered by the eye. It is also desirable that the blocks or strips that receive the laths shall not be spaced more than 12 inches on centres. The exact shape of the furring for beams, coves, cornices, etc., should be shown by full-size details or large scale drawings.

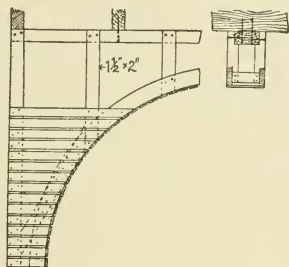

Fig. 192.

**149. Grounds.**—These are usually narrow strips nailed to the walls, furring or studding, around openings to stop the plastering, and also to form a guide for the workman. They are also placed behind baseboards, wainscoting, etc. The position of the ground around the windows is shown in many of the window frame details, Chapter III., by the piece marked *G*, and around door frames by the same letter in Fig. 234; in Figs. 120–122 it is indicated by diagonal lines. Grounds should always be set so that their face will be flush with the plastering and back  $\frac{1}{2}$  inch from the outer edge of the finish (so that the latter will lap that much on to the plaster), and should be *perfectly straight and plumb*. As the plasterer is supposed to bring the plastering to the face of the grounds, if the grounds are not straight or plumb the plastering will not be. It is also obvious that the thickness of the grounds regulates the thickness of the plaster. Where the plastering

is applied to wooden laths the grounds should be  $\frac{3}{4}$  inch thick for two-coat work, and  $\frac{7}{8}$  inch for three-coat work. Where the plastering is applied directly to brickwork or tiling,  $\frac{5}{8}$ -inch grounds are generally used, and also for most of the metal laths. The thickness of the grounds should be given in the specifications; the usual width of the grounds is about  $1\frac{1}{4}$  inches.

For first-class work grounds should be put behind the base, chair rail, wooden cornices and all inside finish to insure that the plastering will be straight. On brick walls grounds also afford a nailing for the wood finish. When the window and door "trim" or casings is made up of several members it is often necessary to put on wide grounds to form a back for the finish. The ground behind the base should be put so as to receive the upper edge of the base and the bottom of the base mouldings, as in Figs. 234 and 269, and it is also desirable to have another ground at the bottom.

In a great many cheaply built buildings the grounds are entirely omitted, except where necessary to form nailings for the wainscoting, the plastering being simply brought to the edge of the door and window frames and carried to the floor, without much regard as to whether it is straight or not. The result of this kind of work is that when the finish is put up the plastering is found to make a wave line behind it, and the irregularity is frequently so great as to cause the finish to be in "wind." The only practical way in which the finish can be made to fit nicely against the plastering is by the use of grounds, and they should always be specified. The woods commonly used for grounds are spruce and the cheaper grades of white pine.

**150. Corner Beads.**—There are two kinds of corner beads used on buildings; A, those which are put up before plastering, and B, those which are nailed to a projecting angle outside of the plastering. The latter kind are included in the interior finish, and will be described under the name of angle beads.

The corner bead proper is really a ground for a projecting angle, as it forms a guide for the plasterer as well as affording a solid corner. The common sections of wooden corner beads and those usually carried in stock are the first two shown in Fig. 193. A much better section is in that shown at B, as it holds the plaster and prevents its crumbling at the edges. It is also about the only section that can be successfully applied to a brick corner. It may be made either  $\frac{7}{8}$  inch or  $1\frac{1}{8}$  inches thick, the latter thickness being best when the bead is to be used on brickwork.

The use of corner beads varies in different localities, in the New

England States they are quite generally used, while they appear to be seldom if ever used in the far Western States. They afford, however, the best protection for a projecting angle, and the author



Fig. 193.—Corner Beads.

believes that it would be better if they were more generally used. The beads should be made of white pine, and should be perfectly straight and plumb.

**151. Metal Corner Beads.**—Within the past three years corner beads made of rolled steel have been patented and placed on the market. The advantages sought in these metal corner beads are to obtain a smaller bead, thereby making a more slightly corner and to hold the plaster so that it cannot crack or crumble away at the angle. They can also be made perfectly straight and can be papered over better than the wooden bead.

To the present time four different patterns have been patented, the *Union*, the *Marsh*, the *Parker* and the *Empire*, all aiming to obtain the same result.

The superiority of one pattern over the others will probably be determined by its adaptation to practical use or the facility with which it can be applied.

At the present time but two of these corner beads, the *Union* and the *Empire*, are on the market; the *Parker* having been absorbed by the owners of the *Empire*, while the *Marsh* has been practically withdrawn.

The *Union* Metal Corner Bead, shown in Figs. 194–196, *A*, has been used quite extensively during the past two years in New England, New York and Philadelphia, and appears to be a meritorious and practical device, especially when applied to wood furring or studding. It is made of No. 24 rolled steel, perforated and cut into strips and bent on a die to the shape shown in Fig. 195 and then galvanized, the zinc coating soldering the sides together where they touch. This bead is made in sizes for  $\frac{3}{8}$ ,  $\frac{5}{8}$  and  $\frac{3}{4}$ -inch grounds and in lengths of 6, 7, 8, 9 and 10 feet;



Fig. 194.

it can be obtained bent to any radius for arches. It is shipped in bundles containing from 60 to 100 feet and weighing from 7 to 20 pounds, according to size and length. The cost of the bead varies from 4 to 5 cents per foot, according to locality.

On woodwork it is secured by nailing through the small holes in the flanges, and can be put up as rapidly as a wooden bead.

On some kinds of brick or tile work it may be secured in the same way, but owing to the nails coming so near the angle they are apt to break the brick or to push out the mortar, so that on brickwork and

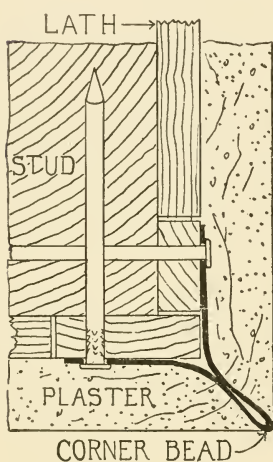

Fig. 195.—Union Metal Corner Bead.  
Full-size Section,  $\frac{3}{4}$ -inch Grounds.

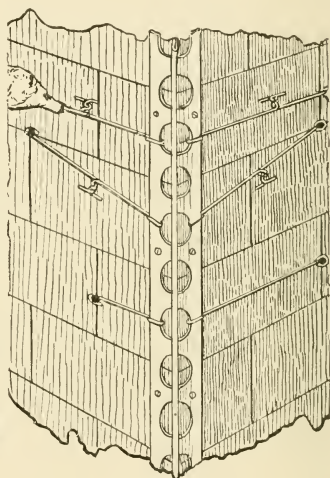

Fig. 196.—Union Metal Corner Bead.

dense tiling better results are usually obtained by securing the bead by means of short pieces of wire hooked to the bead and bent around the head of a nail, driven at a convenient place in the brick or tile work. By using two pieces of wire and twisting the ends together, as shown in Fig. 196, any degree of tightness may be obtained.

The wires for this purpose are furnished with the bead, and the makers claim that a mechanic with helper will put up 300 feet per day in this way and get a straight line.

For irregular brickwork the makers advise that the  $\frac{3}{4}$ -inch bead be

used. When  $\frac{3}{4}$ -inch grounds are used on woodwork the bead may be nailed over laths, as shown in Fig. 195.

This bead appears to have an advantage over those with the edge formed of a single thickness of metal, in that a folded edge is more easily made and kept straight than a raw edge.

The *Parker Corner Bead* was made of a single strip of steel,  $1\frac{1}{4}$  inches wide, perforated to allow the mortar to pass through it, and bent laterally to an angle of 45 degrees. The metal strip was then fastened to strips of wood to facilitate putting it up. This bead, however, has been superseded by the Empire.

The *Empire Steel Corner Plate*, shown in Fig. 198, is especially designed for use on brick and tile corners, although it can be applied equally as well on wood.

The plate is made of No. 16 Bessemer steel (being the scrap from bicycle chain links), not galvanized, and in lengths of from 8 to 12 feet, which are not only perfectly straight, but cannot easily be bent.

The plate is attached to the walls by means of angle irons, which have a key punched out on the side that can readily be en-

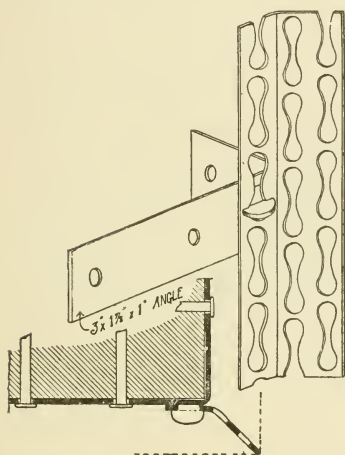

Fig. 198.—Empire Corner Plate, Half Full Size.

gaged in the plate and which at the same time holds it firmly in place. These angles are keyed to the plate before it is put up, at such distances as may be necessary—about 20 inches on an average—and are then nailed to the wall or studding.

The nail holes in the angles are at a sufficient distance from the corner as not to break the bricks or tile, and to get a good hold; moreover, the nails being driven on both sides of the corner, the angle cannot possibly be detached without drawing the nails. The plate should be put up by commencing at the top and working downward, blocking the angles where necessary to keep the alignment.

On woodwork the perforated plate is nailed directly to the wood without using the angle irons.

The manufacturers of this corner bead have also devised a method of ornamenting the edge of the plate by cast brass beadings or ornamental strips in almost any design that may be desired. The cost of this corner plate, including the angle irons, is 6 cents per foot in Philadelphia and adjacent cities, where it is meeting with much favor.

*The Marsh Metallic Corner Bead* consists of a  $\frac{5}{16}$ -inch galvanized steel rod, grooved to hold the plaster, which is held at the desired distance from the rough corner by means of metal clips which are made in forms suitable for applying to brick, wood or steel. This bead gives a rounded corner of about  $\frac{3}{16}$  inch radius. The author understands that it is not now on the market.

When specifying metal corner beads, more satisfactory results will probably be obtained, especially in the smaller towns and cities, if they are included in the carpenter's specifications, as it is important that they be set true and perfectly plumb, and a carpenter is, as a rule, more skillful at such work than other mechanics.

Either a wooden or metal corner bead affords a considerable saving in time to the plasterer, as the bead forms a guide for the trowel, and the plaster has only to be brought to it. To form an "aris" corner in plaster, square and plumb, costs from 4 to 6 cents per foot, so that when a corner bead, and especially a metal bead, is put up by the carpenter, the plasterer should make an allowance on account of it in making up his estimate.

**152. Closing the Building for Plastering.**—When the grounds and corner beads are in place the building should be ready for plastering, as no finished work should be put up before plastering if a first-class job is desired.

Before the plasterer commences work the carpenter should close all outside openings by hanging temporary doors at the entrances and covering the window openings with muslin or old sash. If the weather is not too cold muslin is the best material for closing the window openings, as it allows a sufficient circulation of air to carry off the moisture produced by the drying of the plastering without a decided draught. In very cold weather part of the openings should either be tightly boarded up or filled with temporary sash. (Old sash, when available, are often used.) Store fronts should be boarded up on the outside, so that the front may be finished without removing the boards.

The architect should not allow the permanent sash to be put in until the building is plastered and dried out, as the moisture from the plastering is sure to swell them, and, even if tightly fitted, they are

sure to shrink after a time so as to be very loose. The sash also get more or less stained with plastering, which is never entirely removed.

#### INTERIOR FINISH—JOINERS' WORK.

**153.** Under the heading of interior finish is included all the finished woodwork used inside of a building and put up so as to form an integral part of it; this term also generally includes all work put up after the building is plastered. For distinguishing between the finish that is affixed to the walls, as casings, baseboards, wainscoting, beams, cornices, etc., and cases, cupboards, drawers, shelves, etc., the former is often referred to as the "*standing finish*," while the latter is classed as "fittings." Fittings or fixtures for stores, etc., are generally put in by the tenant, and are not usually included in the contract for the interior finish, but in dwellings everything necessary to complete the building ready for occupancy should be included in the specifications along with the standing finish.

As the primary object of the standing finish is to cover up the rough work and make a finish where the plaster joins the frames, or else to protect the plaster walls, an ornamental appearance is the chief requirement of the work, and to this end smooth surfaces—free from knots, sap or other defects—close joints and freedom from warping and shrinking are necessary, rather than strength and durability.

**154. Finishing Woods.**—The cost and usually the character and quality of the inside finish depends greatly upon whether it is to be of *soft* or *hard* wood, and whether it is to be painted or varnished. As stated in Section 5, the soft woods are commercially classified as those belonging to the conifers, while the hard woods come from the broad-leaved trees. Carpenters, however, usually classify whitewood (poplar), redwood and cypress as soft woods, while hard pine is frequently called a hard wood. Very frequently the term "hard wood finish" is used to designate all work that is finished in varnish in distinction from painted work, although the term "natural finish" is more accurate when any of the pines are used.

For finish of any kind the soft woods are always cheaper than hard woods, even when the price of the lumber is the same. This is principally for the reason that the soft woods (and here we include redwood and cypress) can be used in the solid for making doors, sash, etc.; the greater ease with which these woods can be worked also affects the price, although not to a very great extent.

The difference in the cost of casing a door in clear white pine or oak is not very great (about 75 cents a side for 5½-inch casings), but

when it comes to the doors, a veneered door (and veneering is necessary for most of the hard woods) costs three or four times as much as a solid pine door. Among the hard woods, too, there is quite a difference in the cost of finishing, some of the hard woods, on account of their scarcity, being very expensive (see Section 38), while others, particularly ash and chestnut, are no more expensive than clear pine. Painted work also costs, as a rule, less than varnished work, for the reason that cheaper grades of lumber may be used, and the same care is usually not exercised in putting it up and keeping it clean.

For finish that is to be painted, the first consideration is that it shall stand well, and next to this are freedom from knots and pitch and low cost. These conditions are most fully found in the white pine from the Northern and Eastern States and the sugar pine of the Pacific Coast. Whitewood (poplar) is also extensively used in some localities, particularly for carved work, columns and mantels, and for shelving, etc., as it can be obtained in large dimensions and remarkably free from knots; its softness and uniform grain make it also well adapted for carving that is to be painted. This wood, however, does not stand as well as pine. In a great many localities hard pine is cheaper than white pine, but it contains too much pitch to take paint well. Oregon pine and spruce are also used to some extent for finishing, but they are inferior to soft pine, and the author cannot recommend them for any but the cheapest work.

For interior work that is to be stained or finished in its natural color, the color or grain of the wood most influences the selection when the cost is not a controlling feature.

Aside from the appearance of the wood, however, its hardness is a very important quality, as the softer woods mar and get dented easily, which greatly injures the appearance of the work, and dents cannot be removed. It is for this reason that soft pine, whitewood, redwood and cypress are inferior to oak, ash, beech or maple, although otherwise they make a very attractive finish when properly treated. Redwood, moreover, is very brittle, and the edges break easily.

In regard to their cost, the various woods used for finishing rank in about the following order, commencing with the cheapest, the relative cost varying somewhat with the locality: Whitewood, hard pine, clear white pine, cypress, redwood, ash, chestnut, butternut, red oak, white oak, beech, birch, maple, bird's-eye maple, cherry, mahogany.

Aside from the cost, the last eight woods are usually considered the handsomest and most desirable, although for certain rooms the



other woods are nearly, if not equally, as well adapted. For public waiting rooms and large rooms where a rich finish would hardly be expected, cypress and hard pine are very appropriate and extensively used.

Ash is quite extensively used in churches and large buildings, as it is cheaper than oak and may be used for solid doors. In dwellings all of the woods mentioned are more or less used, hard pine, for varnishing, being frequently used in the kitchen, servants' quarters, etc., and the other woods as the taste and means of the owner dictates or permits. Where a showy but cheap natural finish is desired, whitewood stained in imitation of cherry is often used. Ash is frequently stained in red and greens for the color effect, and the oaks are usually colored slightly in the filling coat. Ash can be colored or stained with ammonia so as to very closely imitate old oak.

The other woods are generally finished in the natural color, although the oil or varnish gives most of them a deeper tone.

The characteristics and qualities of the various woods have been described in Chapter I.

All hard woods and all soft woods that are to be varnished should always be kiln-dried just before they are sent to the building (see Section 12), and it is desirable that *all* of the inside finish should be kiln-dried, but it is not the general custom to kiln-dry woods that are to be painted.

The various woods to be used in finishing the different portions of the building should be explicitly specified before describing the character of the finish.

Except occasionally in wainscoting and in inlaid work, all the exposed finish in a room, including the door frames and doors and the inside of the sashes, should be of the same wood.

**155. Operations in Joinery.**—A large portion of what formerly constituted joiner's work is now done at the mills or woodworking shops, so that the joiner's trade as distinguished from the carpenter's is now confined, in this country at least, to those who work at the cabinet maker's bench or in the shop, the carpenters, as a rule, doing that portion of the work that has to be done at the building. This work consists principally of smoothing and cleaning, joining and putting up the work, the stairs being usually built by a separate class of workmen.

*Smoothing and Polishing.*—All mouldings, except in rare instances where a small quantity and a special pattern are required, are now run or "stuck" by machinery at a moulding mill, and all plane sur-

faces are usually mill planed. Moulding and planing by machinery is usually done by revolving knives, under which the work is drawn by fluted cylinders whose edges, in order to obtain a firm grip of the piece, press so strongly against it as to cause slight transverse indentations on the prominent portions, which injure its appearance very seriously, unless the marks are subsequently smoothed off. Plane surfaces also often have small ridges running parallel with the grain, and the surface is rough, especially with the harder woods.

In very cheap work the finish is put up as it comes from the machine, with the indentations and rough surfaces, but for buildings where a good finish is desired, the specifications should require that all finishing lumber be smoothed and sandpapered before putting up, as, unless it is specified, the carpenter may refuse to do it.

In the case of mouldings, the smoothing is usually done with sandpaper, although the raised flat surfaces should be smoothed with a plane. All plane surfaces, such as the face of bases, casings, beaded ceiling, etc., should be smoothed with a smoothing plane, and the hard woods should be scraped with a piece of hard steel made for the purpose.

Most of the large woodworking establishments have machines which polish the plane surfaces by passing them between steel rollers, one of which is covered with fine sandpaper. Work finished in this way is superior to that smoothed by hand, but very little polished work is sent to the building, except where it is worked or put together at the shop. Paneled and stair work, cases, mantels, etc., are generally made at a shop, and such work is always smoothed before being put together.

**156. Joining the Work.**—A very important requirement of interior finish is that the joints shall be as tight and inconspicuous as possible, and, in fact, it was in the character of the joints and in the smooth surfaces and the smaller dimensions of the pieces that the distinction between joinery and carpentry arose.

The various joints made in connecting interior finish and fittings may be classified under one or more of the following kinds, viz.: butt joints, tongue and grooved joints, splined joints, mitred joints, coped joints, covered or housed joints, glued and blocked joints, and dovetailing, and the work is said to be butted, matched, mitred, coped, housed or rebated, glued and blocked, or dovetailed, according to the kind of joint that is made. Very frequently two of these operations are combined in a single joint.

*Butt Joints.*—A butt joint is made by simply butting one piece

against the other, as at *A* and *B*, Fig. 199. This is the easiest joint to make, but is objectionable, particularly in varnished work, in that any shrinkage in the board *b*, or in either or both of the boards at *B*, will cause the joint to open, as shown by dotted lines, and of course the greater the width or thickness *d*, or the wider the boards in *B*, the greater will be the shrinkage. Another objection to this joint is that it is difficult to keep the surfaces joined in exactly the same plane, also when casings are joined, as at *A*, the end wood is exposed on the side, although the last objection can be overcome by placing a back band around the outer edge of the casings.

The principal instances in which butt joints are used in interior finishing are in joining plain or O. G. window casings, and where block and pilaster finish is used. (See Figs. 234 and 237). The butt joint is also used in flooring.

*Tongued and Grooved Joint.*—This is a form of butt joint in which one surface or edge is grooved, while the other has a tongue worked

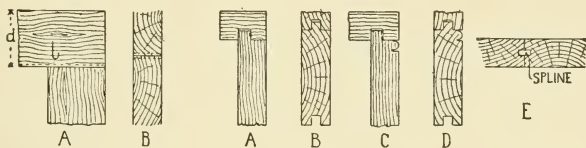

Fig. 199.—Butt Joints.

Fig. 200.—Tongued and Groove Joints.

on it to fit into the groove, as shown at *A* and *B*, Fig. 200. The object of the tongue and groove is to keep the surfaces joined flush with each other, and also when the end is tongued it prevents the board from warping; in case of shrinkage the tongue also prevents dust from passing through, but it does not prevent the appearance of an open joint. To overcome the bad effect produced by shrinkage, a bead is often worked next to the tongue, as in *C* and *D*, the joint then having the same appearance as the quirk on the other side of the bead, unless the shrinkage is very great. Boards tongued and grooved, as at *B*, are called "matched" boards, and when beaded are called matched and beaded: if there are two beads it is "double beaded," and if there is a bead at the centre it is "centre beaded." The tongue and groove is extensively used on flooring and sometimes on sheathing, while the matched and beaded joint should be used for ceiling.

A *splined joint* is practically the same as a tongued and grooved

joint, except that both edges are grooved, and the tongue or "spline," as it is called, is made of a separate piece, as at *E*. Splined joints are not as frequently used as the tongue and groove; in joining very thick stuff, as 3 or 4-inch planking, the spline is more economical of material, and in making a very fine joint it is superior to the tongue and groove.

**157. Mitre Joint.**—A mitre joint is made by beveling the parts joined so that the plane of the joint bisects the angle. It is used in making the external angles of bases, all horizontal mould-

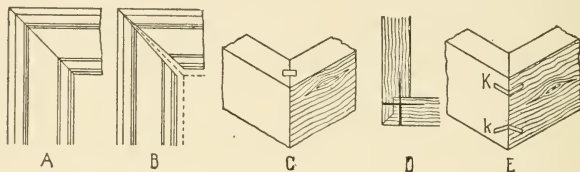

Fig. 201.—Mitre Joints.

ings, fine wainscoting, etc., and in fine cabinet work; also for making the angles where mouldings are carried around openings.

With a true mitre all parts of the mouldings intersect perfectly, as at *A* Fig. 201.

When skillfully done the mitre makes the handsomest joint, and in many places, as with panel moulds, it is the only joint that is practicable. A mitre joint, however, has the disadvantage that any shrinkage in the wood causes the joint to open at the inner edge, as

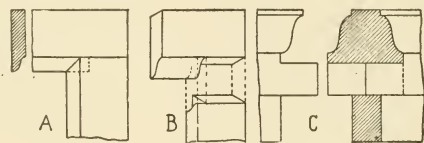

Fig. 202.—Coped Joints.

shown at *B*, where the dotted lines show the pieces when first joined, and the full lines show the pieces after they have shrunk. It is not uncommon to see door and window casings that have shrunk so as to open the joint a quarter of an inch. This, of course, looks very bad, and hence the mitre joint should only be used when the wood is thoroughly kiln-dried and not allowed to swell afterwards, as no mechanical device will prevent wood from shrinking.

*Mitre Joints for Bases, Wainscoting, Built Posts, etc.*—In the cheaper grades of work the pieces are simply mitred and glued or nailed together. Such a joint is not very strong, as the glue does not hold very strongly on the end wood, and neither do nails. When a plain mitre is used in cabinet work, the edges should be grooved and a hard wood dowel should be glued and driven in, as at *C*, Fig. 201.

A still better joint is that shown at *D*, as the parts can be securely nailed from both faces, and portions of the joint are parallel with the grain. Where internal angles are mitred and glued before putting up, the joint may be strengthened by inserting thin strips of hard wood, called “keys,” in the back of the joint, as shown at *E*. These may either be horizontal, as at *K*, or inclined, as at *k*, the latter being

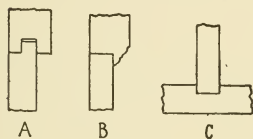

Fig. 203.

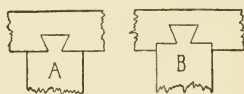

Fig. 204

the stronger. All of these joints, slightly modified, are applicable to acute and obtuse as well as to right angles.

For first-class work all mitre joints should be glued and further strengthened by dowels, blocks or brads. Mitre joints for casings are described in Section 168.

*Coped Joint.*—A coped joint is only used in connection with mouldings; it is made by cutting the end of one moulding to fit the profile of the other, as in Fig. 202. When nicely made a coped joint cannot be distinguished from a mitre joint, that is if the mouldings are alike and not too elaborate. When one moulding comes against another of a different pattern, the one which is stopped should be coped to the other.

Sash bars or muntins, the rails and stiles of sashes and of solid moulded doors and paneling, ogee casings, etc., are usually coped.

A coped joint has the advantage over the mitre joint in that any shrinkage in the piece that is coped does not open the joint, and if the other piece shrinks the joint does not open as badly as with a mitre joint. Only comparatively plain mouldings, however, can be successfully coped.

*Covered and Housed Joints.*—The author has used the term “cov-

ered joint" to designate those joints in which the edge of one part laps over on to the face of the other, usually from  $\frac{3}{8}$  to  $\frac{1}{2}$  inch.

When two pieces of finish are joined parallel with the grain a covered joint should be used when possible, as it permits the parts to shrink moderately without opening the joint. The joint is usually made by rebating or ploughing the edge of the projecting piece, as at *A* and *B*, Fig. 203. Rebated or ploughed joints are always used in making paneled work, and with raised mouldings, back bands, etc.

A *housed joint* is one in which the end or edge of one piece is wholly let into the side of the other, as at *C*, Fig. 203. Housed joints are used principally in joining the ends of stair treads and risers to the wall string, and to a closed string, and in uniting the angles of cisterns and tanks. It makes a strong as well as a neat

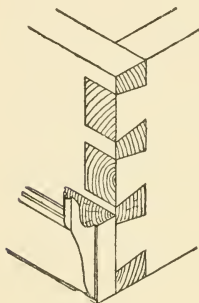

Fig. 205.—Common Dovetail.

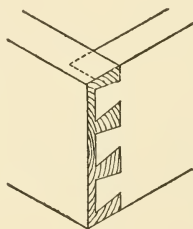

Fig. 206.—Lapped Dovetail.

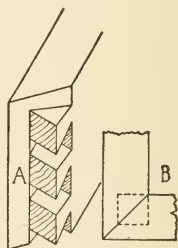

Fig. 207.—Secret Dovetail.

joint for such places. A ploughed joint like that at *A*, Fig. 200, is sometimes called a housed joint, but the author prefers to confine the latter term to a joint like that at *C*, Fig. 203.

**158. Dovetailing.**—A "dovetail" is a tenon or pin, made in the shape of a truncated wedge, the outer end being the wider, as shown in Figs. 204–206. Such a tenon, when fitted into a mortise or groove of corresponding shape, obviously cannot be drawn out without shearing the wood, hence a dovetail joint is very strong, irrespective of glue or nails. Dovetailing, however, is seldom used in joining standing finish, being confined principally to fittings, cabinet work and furniture. Still there are places in other kinds of work where the dovetail makes the best joint and should be used in preference to other joints.

Details *A* and *B*, Fig. 204, show dovetail joints suitable for re-entering angles in joiners' work. That at *A* is also used for securing the balusters of stairs to the treads.

Fig. 205 shows the *common dovetail* joint for external angles. This is the strongest joint, but is not used in cabinet work, except where the pin ends showing on the face can be covered with a moulding.

The joint shown in Fig. 206 is called a *lapped dovetail*, because the front laps over the ends of the pins so that they do not show on the face. This makes nearly as strong a joint as the common dovetail, and is largely used in uniting the front and sides of drawers.

For highly finished drawers and boxes the *mitre or secret dovetail*, shown in Fig. 207, is sometimes used by cabinet makers. Only one of the boards to form the angle is shown in detail, the other being made to fit the projections and indentations of the one shown. When put together this joint has the appearance of a mitre joint, but as the dovetails have only one-half as much holding surface, it is only about half as strong as the lapped dovetail, and the latter is to be preferred for large drawers. Dovetailed joints in joinery are always glued.

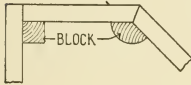

Fig. 208.

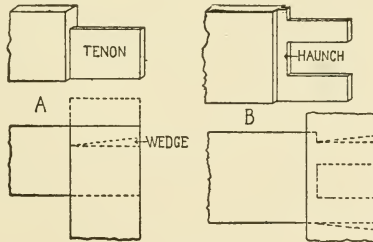

Fig. 209.

*Glued and Blocked Joint.*—Many joints in joinery and cabinet work are made by gluing the connecting parts together, and also gluing blocks of wood into the re-entering angle, as in Fig. 208, to further strengthen the joint and preserve the shape of the angle. Such work is said to be "blocked and glued," and as long as the glue holds it makes a strong joint.

For all sorts of curved surfaces small blocks are glued together and then covered with a veneer, or sometimes the wood is bent to the form required and blocks are glued on to the back to keep it so.

Glue is also used by itself to connect the edges of boards in making one wide board, and when the grain of the wood is carefully matched the joint can hardly be detected. If the boards are thoroughly dry and a good quality of glue is used, the joint will be as strong as the solid wood.

Glued joints, however, sometimes come apart through continual changes in temperature and humidity, or because the wood was not thoroughly dry, so that it is always best to strengthen the joints by dowels, or by a tongue and groove.

Glue is very extensively used in the best grade of joinery and in cabinet work, but it is best not to depend upon it entirely, except in the case of veneers, etc.

**159. Framing.**—All large pieces that are free to warp and twist, such as doors, shutters, sashes, etc., and interior panel work of every kind, should be "framed" together by making a frame of boards running parallel with the outside edges of the work. The space enclosed by the "frame" is usually filled with panels made of wood or glass. Wood panels may be set flush with the frame or sunk, as preferred. When the piece is very large—exceeding 2x3 feet—the frame should be divided into two or more panels by cross pieces, framed into the outer pieces. As the boards or planks used in forming the frame are usually not more than 6 inches wide, and often not more than 2 or 3 inches, the size of the frame is but little affected by shrinkage, while the shrinkage that would naturally occur in so wide a piece

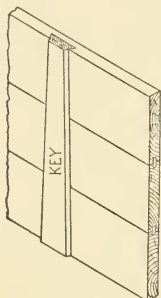

Fig. 210.

is taken up by the panels, which should be so arranged that the effects of shrinkage or swelling will not be apparent.

Framed work is also less likely to warp than any other arrangement of pieces, owing to the grain in the different parts of the frame running in different directions. The greater the number of panels, also, the less is the liability to warp.

The pieces forming the frame should always be joined by mortising and tenoning, which is similar to the same operation in carpentry, except that it has to be done with greater care and neatness.

The tenons should have a thickness from  $\frac{1}{4}$  to  $\frac{1}{3}$  that of the frame, and the breadth should be about  $\frac{2}{3}$  of the breadth of the piece, but no single tenon should be more than 4 inches wide, as a broad tenon may shrink considerably and get loose, besides necessitating a wide



mortise, which might weaken the frame too much. Hence when the wood is wide—generally if over 7 inches wide—a double tenon should be used, as at *B*, Fig. 209. This drawing also shows a haunch on the tenon, which is seldom used, however, except in the very best work.

When the mortise comes at the end of a stile or rail the tenon is usually cut as at *A*, and the piece containing the mortise should be left long, as shown by the dotted lines, and not cut off until the glue is hard.

The tenon should be secured in the mortise by wedging and gluing, as shown by the dotted lines, the mortise being cut a little large to accommodate the wedges. In cheap doors the tenons are often secured by pins which show on the face, but this method of fastening is inferior to the wedged joint.



Fig. 211.

160.—When plain surfaces of boarding of considerable extent are required for wainscoting, dadoes, etc., they should be built up of narrow boards—3 to 4 inches wide—carefully jointed, doweled and glued together edge to edge, and keyed on the back by tapering pieces of kiln-dried hard wood let into a wide dovetail groove, as shown in Fig. 210. These keys keep the surface of the boards in the same plane and allow the work to shrink and expand with changes in the humidity of the room. They should be driven tight but not glued.

In fitting the boards together they should be placed so that the direction of the annual rings in each piece is reversed.

Very often the edges of the boards are grooved and a hard wood strip or “spline” let in the whole length to strengthen the joint, but dowels are superior for the reason that a groove leaves a thin tongue of wood on each side of the board, which is liable to curl and thus cause the joint to open, as in Fig. 211. When dowels are used no such defect is likely to occur, as the edges of the boards are not cut except at intervals where the dowels are placed, and then only by holes just large enough to receive them.

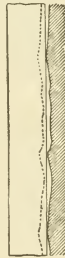

Fig. 212.

When it is desired that a dado shall appear like one wide board of hard wood, a backing of pine should be glued up, as described above, and the face then covered with a thin veneer of the finished wood. In the very best work two thicknesses of veneering are used, as described in Section 178.

Occasionally doors are designed to appear as if made of a single

plank of wood—generally of some expensive hard wood. To obtain this effect and at the same time have a door that will not warp, the door must be framed and filled with flush panels and then veneered with two thicknesses of very fine veneer, as described in Section 165.

*Scribing.*—This is the operation of bringing the edge of a piece of wood, usually a long strip, to fit close to an irregular surface, as in fitting the edge of a board to a plastered wall that is not a true plane or to rough stonework. It is done by placing the board so that it will be parallel to its intended position and as near to the irregular surface as convenient, and then setting a carpenter's compass so as

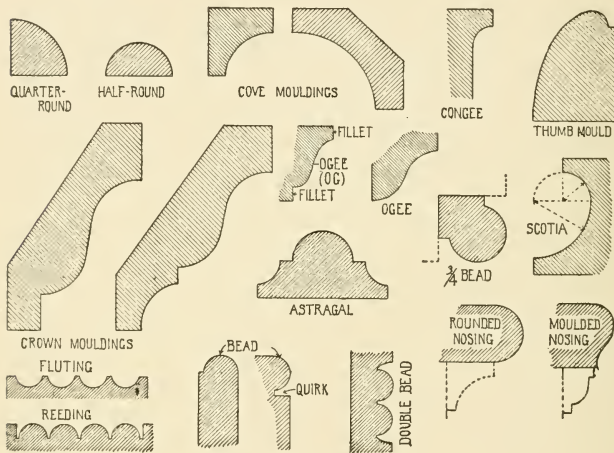

Fig. 213.

to cut off just enough to give the proper width to the board; one point is drawn along the irregular surface while the other is made to scratch a line on the face of the board, as shown by the dotted line, Fig. 212. This line will, of course, be exactly parallel to the profile of the surface, and when the board is cut it will fit exactly in position.

*Putting up the Finish.*—This is the last operation performed by the joiner, and as it varies with different kinds of work, it will be described in connection with the finish.

**161. Mouldings.**—Although the mouldings used in connection with the interior or exterior finish of the better class of buildings are

usually made in accordance with the architect's full-size details, and hence are seldom exactly alike in any two buildings, yet there are certain shapes that are so commonly used as to have specific names, while class names have been given to mouldings used for particular purposes, irrespective of the shape of the members. As these names are in common use among builders and architects, and are often used in the specifications, it seems advisable to define them before entering upon a description of the finish.

*Names of Mouldings.\**—In Fig. 213 are shown sections of such mouldings as are used with so little variation that a name may be given to them. These mouldings may vary in size†, but the shape is always practically the same.

Most of these terms require no further explanation. The quirk is

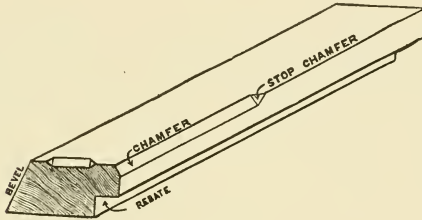

Fig. 214.

not a moulding proper, but is the little groove formed at the side of a moulding that is sunk below the surface, being most commonly used with the bead or torus. Beads are extensively used in interior finishing, often with the quirk, to conceal a joint. When several of them are used together in the centre of a board they are called "reeding." The term "fillet" is used to designate a narrow, flat surface—usually not more than  $\frac{3}{8}$  inch wide—on each side of a moulding or separating mouldings. Fluting may have either rounded or square channels, the rounded being generally understood. Moulded nosings may be of almost any shape, but are generally rounded on top. Besides these names which indicate the shape of the mould-

\* All of the mouldings used in connection with the Five Orders of Architecture have specific names, but many of them are practically obsolete, and only such names are given here as are in common use.

† The mouldings shown in Figs. 213 and 215 are drawn from one-third to one-half of the more common size.

ing there are also two terms—"solid" moulding and "sprung" moulding—which apply to mouldings of different outlines.

A *solid moulding* is one in which the wood fills the space behind the moulding proper, usually to a right angle. A *sprung moulding* is one worked from a board or thin piece so that the back is parallel to a line tangent to the face, and when the moulding is set in its proper position against a board there will be a space behind it. The crown mouldings shown and the larger cove moulding are "sprung mouldings," while the others are solid mouldings. Bed mouldings (see Fig. 215) are usually sprung mouldings unless quite small. Besides mouldings proper, there are also the *bevel*, *chamfer* and *rebate*, shown in Fig. 214, that are extensively used in joinery.

*Kinds of Mouldings.*—These are mouldings used for distinct purposes; they may, and usually do, vary much in their profile, but the

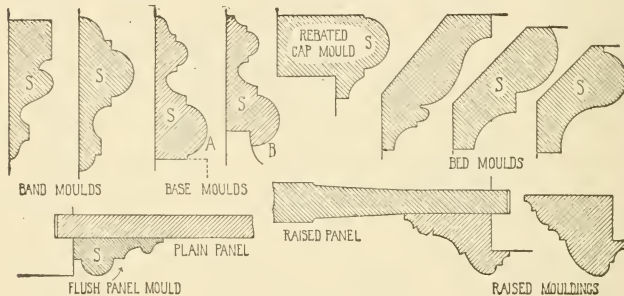

Fig. 215.

general shape is usually about the same for each kind of moulding. Those terms which are generally recognized by carpenters and millmen are illustrated in Fig. 215.

A *band mould*\* is one that is nailed or glued to the face of other parts of the finish. A *bed mould* is one used in the angle formed by a soffit and vertical surface. *Raised mouldings* are used principally in connection with panel work and are almost always of the general shape shown. Flush panel mouldings are made in a variety of patterns, but one with a quirk next to the stile or rail is best, as it will not show the effects of slight shrinkage.

\*The term "mould" for moulding is here used because it is almost universally used by mechanics when a prefix is added.

The base mould, *A*, square at the bottom, may be used when a plain board is used for the base. If the base is moulded a rebated base mould is preferable. Base mouldings should be comparatively thin at the top so that they may be sprung to fit the plastering if the latter is not perfectly straight.

Mouldings are said to be "planted on" when they are nailed or glued to the face of a wider moulding or board. Band mouldings are always planted on. The term "stuck moulding" is sometimes used to designate a moulding that is worked on the edge of a board or plank, but the work "stuck" more commonly refers to the making of the moulding, *i. e.*, passing through the machine.

*Stock Mouldings.*—A great many mouldings are carried in stock by the larger lumber dealers, and a book is published by a central publishing company giving the full-size sections of the mouldings usually kept on hand.

Most of the mouldings shown in Fig. 213, and those marked *S* in Fig. 215, are stock mouldings. When only small quantities of mouldings are needed it is cheaper to use stock patterns, and they can usually be made to answer for the exterior finish of moderate priced houses. The speculative builder uses them altogether as a rule. For the interior finish and on the exterior of the better class of buildings the architect usually prefers to design the mouldings himself, and in such case he should specify that "all mouldings are to be stuck according to the full-size details."

*Price.*—Mouldings are universally sold by the lineal foot, the price for the same wood varying with the number of square inches in the cross section of the piece *from which the moulding is worked.*

Hence in writing specifications for estimates, if the full-size details are not to be furnished at that time, the architect should specify the size of the wood from which the various mouldings are to be worked, and then the contractor can estimate as accurately as if he had the profile, as the latter does not usually affect the cost.

When several mouldings are used together each piece is called a member, and the number of members with their size should be specified.

Almost any moulding that the architect chooses to design can be made by machinery, but those which are "under cut" are more difficult to work than those that are not.

**162. Detailing the Finish.**—As most of the individual mouldings with which interior finish is ornamented are usually quite small, they can be properly shown only by full-size details, while to study the

relation and proportions of the parts, drawings made to a scale of  $\frac{1}{2}$  or  $\frac{3}{4}$  of an inch to the foot (usually called "scale details") are of the greatest assistance, and in the case of elaborate work, such as staircases, mantels, sideboards and other fittings, are quite indispensable. As a rule the architect will obtain the best results with the least labor by drawing all special finish to one of the scales above mentioned and then showing the profile of the mouldings by full-size sections, without attempting to draw the entire object full size. All important dimensions should be indicated in figures on the scale details the same as on a plan. All carving should also be drawn full size, but where it is symmetrical but one-half need be shown.

Nearly all work that is built in or made a part of the building has to be made to fit the constructional portions, and as these usually vary slightly from the plan, even when the work has been very carefully done, it is customary for the person that is responsible for the proper execution of the finish to make careful measurements of the building after the grounds are set, and from these measurements to lay out the work, if it is to be put together at the shop, full size, making it as near as possible like the architect's drawings, but so that it will perfectly fit the place where it is to go. Thus it is seldom that elaborate work is put together directly from the architect's drawings, although when completed it may appear so, and hence much time is often wasted by the architect or his draughtsman in making drawings that, except for the sections, are of no practical use.

Mouldings, however, are usually made exactly in accordance with the architect's sections, the knives being made to fit the drawings, and drawings for turned work are usually carefully followed, hence the necessity for carefulness in making such drawings.

In making the full-size sections the draughtsman usually has first in mind the effect that will be produced by their shades and shadows (as it is these alone that give values to the mouldings), but it is fully of as much importance to design the work so that when put together its appearance will not be spoiled by the first shrinkage or swelling that takes place, and this it must be remembered cannot wholly be avoided in woodwork.

Methods for overcoming the effects of shrinkage will be considered in describing the finish, but the following general rule for good joiner's work should always be kept in mind, viz.: always use narrow boards in place of wide ones, and wherever practicable always fix the work so that it will be free to expand or contract. Open joints and split panels or boards spoil the appearance of the finest work and injure the reputation of the architect.

The experienced architect or draughtsman may also do much to keep down the cost of the work by drawing his mouldings so as to require the least amount of material without sacrificing their appearance. Nearly all of the finishing woods are sawn to thicknesses of  $\frac{1}{2}$ ,  $\frac{3}{4}$ , 1,  $1\frac{1}{4}$  and 2 inches, and when dressed both sides they lose  $\frac{1}{8}$  inch in thickness. When run through the moulding machine or planer this thickness is again reduced by about  $\frac{1}{16}$  of an inch, so that all moulded members should be drawn either  $\frac{5}{16}$ ,  $\frac{9}{16}$ ,  $1\frac{1}{8}$ ,  $1\frac{1}{16}$ ,  $1\frac{5}{16}$  or  $1\frac{3}{4}$  inches thick to utilize the wood economically. The nominal size of mouldings is that of the rough lumber; "inch stuff" when worked into mouldings being actually but  $\frac{3}{8}$  of an inch thick, although it is

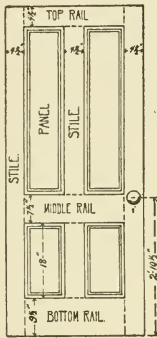

Fig. 216.

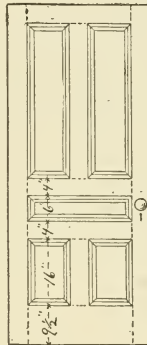

Fig. 217.

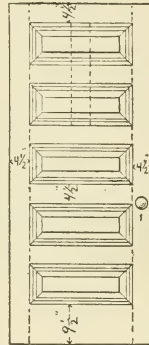

Fig. 218.

charged as if an inch thick. In the same way a 6-inch board is usually a quarter of an inch narrower, and stock casings are often measured  $\frac{1}{2}$  inch wider than their actual width.

DESCRIPTION OF THE FINISH.

**163. Doors.**—These are not always classed as a part of the interior finish, but they form a very important part of the interior woodwork and often give more trouble than the standing finish.

*Stock Doors.*—In houses costing less than \$4,000 it is generally necessary to use "stock doors." These are made of pine, and sometimes of whitewood, of certain regular sizes and thicknesses, and are always kept in stock by lumber dealers. Three qualities of stock doors are usually kept on hand, viz.: A, B and C; the A doors, which are the best, being of clear stock and usually well made. B

doors contain a few small knots, and perhaps some sapwood, but will answer for common painted work. C doors should never be specified, as they are unsuited for any but the cheapest class of work. Cypress doors of different designs are also carried in stock in some Eastern cities.

There is a difference in the construction of stock doors. The better class of doors have the tenons glued and *wedged*, as in custom work, while a cheaper kind are merely glued and pinned with wooden dowels which show on the face.

From the fact that stock doors are kept on hand in a storehouse for some time it is impossible to keep them thoroughly dry, so that they are quite sure to shrink when subjected to furnace heat, and if made of whitewood they are also quite liable to warp or "spring."

*Size and Thickness of Doors.*—Stock doors are made  $1\frac{1}{8}$ ,  $1\frac{3}{8}$  and  $1\frac{3}{4}$  inches thick. The first are sometimes used for closet doors, but the  $1\frac{3}{8}$ -inch thickness is generally used for all inside doors less than 3 feet in width and 7 feet in height. Sliding doors, however, should

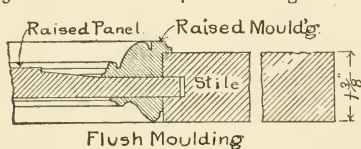

Fig. 219.

always be at least  $1\frac{3}{4}$  inches thick, and also all doors 3 feet or over in width or exceeding 7 feet in height, and all outside doors. The sizes of stock doors vary from 2 to 3 feet in width and from 6 feet 6 inches to 7 feet in height, being always made in even inches. The height in inches, above 6 feet, is seldom made less than the width in inches above 2 feet, thus 2 feet 8 inches by 6 feet 6 inches or 2 feet 10 inches by 6 feet 8-inch doors are not usually kept in stock.

*Construction.*—Stock doors are as a rule divided into four panels, as shown in Fig. 216, and (in the Eastern and Middle States) may be obtained with plain or raised panels, flush or raised mouldings, as desired. A four-panel door answers



Fig. 220.

very well for sizes not exceeding 2 feet 10 inches by 7 feet, but for larger sizes it is hardly stiff enough.

Five-panel doors, divided as shown in Fig. 217, are sometimes kept in stock. This makes a good strong door, well suited for tenements, schools and buildings of a public nature.

An objection to the ordinary four-panel door is that the middle



rail comes at the same height as the lock, so that the mortise for the latter cuts away a large part of the tenon, thereby weakening the door. In a door paneled as in Fig. 217 the lock comes opposite the middle panel and hence does not weaken the door to the same extent.

The rails of a door are always tenoned into the outer stiles, which extend the full length of the door, and the middle stile is tenoned into the rails. The panels are set in as shown in Fig. 219, which shows a raised panel and moulding on one side and a plain panel and

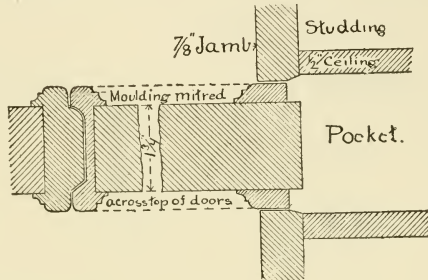

Fig. 221.

a flush moulding on the other side. The mouldings are usually fastened in place by small nails or brads, which should not penetrate the panels.

*O. G. Doors.*—The stock doors commonly sold throughout the West do not have a separate panel mould, but an ogee moulding is

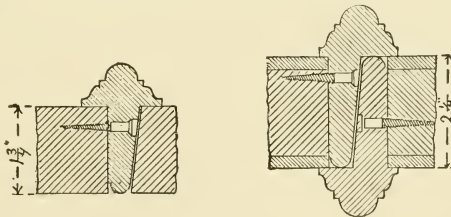

Fig. 222.

Fig. 223.

worked on the edges of the rails and stiles, as shown in Fig. 220, hence these doors are commonly called *O. G. doors*. They are a little cheaper than the moulded doors, but are not as good a door, as the panels are not held as securely, and they sometimes shrink so as to draw out of the groove.

In most of the larger cities several patterns of "front doors" are carried in stock which answer very well for cottages, but are seldom good enough for a house costing over \$2,500.

*Sliding Doors.*—When a stock or other door is to be used as a sliding door a meeting moulding, similar to that shown in Fig. 221, should be glued and bradded to the meeting edges of the doors and a small moulding, corresponding with the projecting portion of the meeting mouldings, should be carried across the top and down the back of the door. These mouldings fit against the jamb and prevent

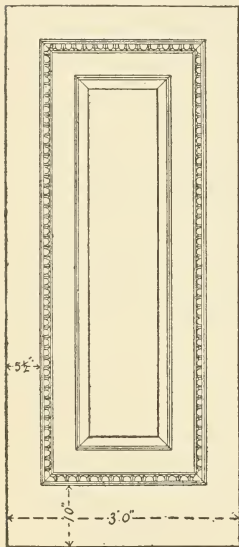

Fig. 224.

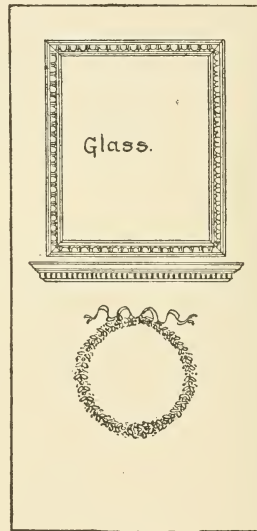

Fig. 225.

the face of the door from getting scratched. The tongue and groove on the meeting moulding may be either beveled or curved, as desired.

*Double doors*, hung with butts, often have the meeting rails rebated, which answers well for inside doors, but for outside doors it is better to screw an astragal or weather moulding to the edge of the standing part, as shown in Fig. 222. This protects the joint from the weather and also keeps the doors together better. With very heavy doors an astragal should be screwed to each door, as shown in

Fig. 223 The above suggestions apply either to stock or custom-made doors.

**164. Custom-Made Doors.**—These include all doors that are made to order from the architect's drawings. They should be made of stock that has been well air-seasoned and thoroughly kiln-dried, and, if of hard wood, should be veneered on a pine core. The specifications should describe all particulars of their manufacture, and inch or  $\frac{3}{4}$ -inch scale drawings should be made, with the width of the stiles, rails and panels carefully figured. All mouldings and ornamental work should be drawn full size.

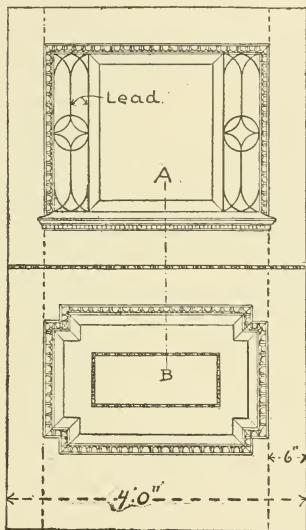

Fig. 226.

*Solid* doors are usually made in much the same way as stock doors, except that more care is taken with them, and they are kept perfectly dry. If the architect wishes to have the doors made in the best manner, he should also require that the tenons be made with haunches, as shown in Figs. 209 and 227, and that the panels be put in without bradding or gluing, as described in the following section.

When the doors are to be made to order the panels may be arranged as desired, although the cost of the door depends largely upon the number of panels. For solid doors, and for ordinary veneered doors, an arrangement of panels like that shown in Fig. 218 is very satisfactory, as it

makes a very strong and good proportioned door and the panels are not so wide as to cause excessive shrinkage. The two upper panels may be reversed, as shown by the dotted lines, if desired.

Fig. 224 shows a door having but a single panel, which may be used either as an inside door or as a front door. Figs. 225 and 226 show two designs for outside doors, the latter being cut in two horizontally, so that it is really two doors. This style of door is usually called a "Dutch" door. Doors with panels over 12 inches wide

must be made with much more care than doors with narrow panels. The thickness of doors with large panels, such as is shown in Figs. 224 and 226, should not be less than 2 inches for doors 3 feet 4 inches wide and under, and  $2\frac{1}{4}$  inches for doors over that width.

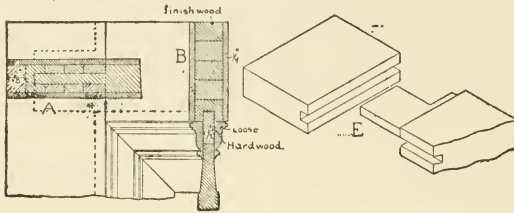

Fig. 227.

**165. Veneered Doors.**—Doors which are to show hard wood finish should be constructed as shown in Fig. 227, and pine doors, intended for a finely finished room, should be made in the same way. The stiles and rails are made by sawing  $\frac{3}{8}$  clear pine boards into strips as wide as the door is to be thick, less  $\frac{1}{2}$  inch, and carefully gluing them together, face to face, until the width of the stile or rail is obtained. The outer edge of the stiles is covered with a  $\frac{3}{8}$  strip of the finish wood. The core thus made is covered with a veneer of hard wood  $\frac{1}{4}$  of an inch thick. The rails are tenoned into the stiles in the usual way, except that a  $\frac{1}{2}$ -inch haunch is left the full width of the rail (less the groove for the panel tongue) which fits into the groove in the stile as shown by the isometric drawing *E*. The panels are not tongued into the stiles and rails, but a hard wood strip of the thickness of the panels is

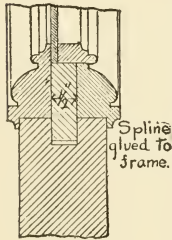

Fig. 228.

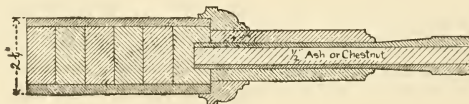

Fig. 229.

glued into them instead. Against this strip the panel mouldings are glued, thus leaving the panel loose and free to move. If the panels of solid pine doors were secured in this way there would be no chance

for the panels to crack. When the door contains a single glass panel a strip should be glued into the stiles and rails as if for a panel, but the inner panel mould should be cut off flush with the top of the strip and a separate moulding, wide enough to cover both the strip and the panel mould, should be tacked in to hold the glass, as shown in Figs. 228 and 230.

If the panels are very wide they also should be veneered, the grain of the core running at right angles to that of the veneer. Fig. 229 shows a section through the stile and panel of the door shown in Fig. 224, and Fig. 230 represents a section on line *A B*, Fig. 226.

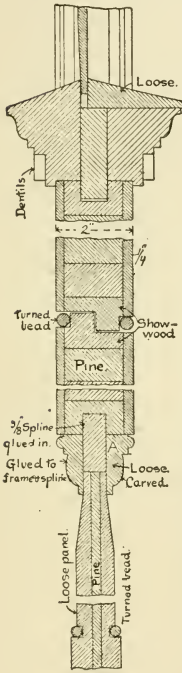

Fig. 230.

Fig. 231 shows a section through a door, made in two halves and glued together, the paneling on the opposite sides of the door being different.

When a door or wainscot is made to appear like one wide board or a number of boards glued together flush with each other, as in the door Fig. 225, a different method of veneering and building up must be employed. For such a door the frame is glued up in the usual way, and the flush panels are made by gluing a number of pieces of pine, ash or chestnut, 3 or 4 inches wide, together edgeways, taking care that the direction of the annual rings in each piece is reversed, as shown at *B B* in the horizontal section, Fig. 232, which shows the construction of the bottom portion of the door shown in Fig. 225. The edges of the strips are also doweled together, as shown in the section.

On the door thus formed are glued four veneers, each about  $\frac{1}{8}$  of an inch thick, two on each side, in such a way that the grain crosses; the grain of the core and the finish running in parallel directions. The inner or cross veneer is usually of oak.

The advantages of doweeling, in place of hard wood strips set in grooves the whole length of the edge, were explained in Section 160.

If the door is to be ornamented by carving below the surface the

core must be cut out after it is cross veneered, and a block of finish wood of the same color and grain as the veneer set in at the proper place to receive the carving, as shown at *A*, Fig. 232. If the carving is to be above the surface, as in Fig. 225, a piece of the finish wood is first sawed to the outline of the carving and then glued to the door, after which it is carved.



Fig. 231.

The above paragraphs and illustrations show how doors should be detailed and made, but it is impossible for the architect to be sure that they have been built as specified unless he can see them in process of construction at the shop. The contract for fine interior woodwork should therefore provide for a strict guarantee of the quality and durability of the work, and even then it is much better, both for the architect and his client, to let the work only to a firm having an established reputation for first-class work.

**166. Patented Doors.**—The methods of door construction thus far described are not protected by patents, and can be adopted by

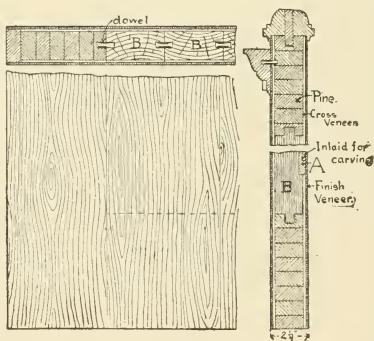

Fig. 232.

any one having the necessary facilities. There are, however, a few devices for doors that have been patented, and can therefore be used only by the patentees or under license.

Fig. 233 shows a section of stile (half full size) of a patent veneered door\*, the patent applying to the manner in which the veneer is ap-

\* Made by the Compound Door Company.

plied. The interlocking of the core and veneer doubles the gluing surface, thus preventing the veneer from peeling, warping or checking. This construction is especially desirable for outside veneered doors.

There are also special kinds of doors, such as flexible doors, or rolling partitions, revolving doors, etc. These are described in Appendix A. Special methods of hanging doors of several folds for closing wide openings are described in Section 213.

**167. Door Frames and Finish.**—The construction of inside door frames varies in different portions of the country. In the New England and some of the Middle States the frames are usually made out of  $1\frac{3}{4}$ -inch plank, rebated  $\frac{1}{2}$  inch for the door, and, in the better class of work, beaded on the edge, as shown at *D*, Fig. 234. The side pieces or jambs are housed or let into the head and nailed from the top. In some if not all of the Western States the frame is made

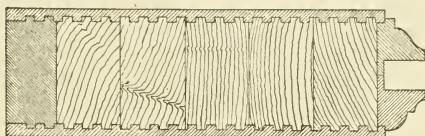

Fig. 233

of plain  $\frac{3}{4}$  or  $1\frac{1}{8}$ -inch boards housed together, and with a stop nailed or screwed to the frame for the door to strike against, as shown at *E*. The former method is probably the best for heavy doors, as it gives more depth of wood for the screws, but in wood partitions a frame such as is shown at *E*, if  $1\frac{1}{8}$  inches thick, can be made perfectly solid and will hold any ordinary door. Besides being the cheaper frame it has the advantage that the door can be changed to swing on the other side of the partition by reversing the stop bead, and the head of the frame is at the same level on both sides of the partition.

A frame such as is shown at *D* has the disadvantage that owing to the rebate the casing or trim will be  $\frac{1}{2}$  inch higher on one side of the partition than it is on the other, and if two doors come near together and swing on different sides of the partition the difference in the height of the head casings will be very noticeable. This may be overcome, however, by rebating both edges of the frame.

In setting the studding the rough opening should be of such a width that there will be about  $\frac{3}{4}$  or  $\frac{7}{8}$  of an inch between the back of

the frame and the stud to allow of plumbing the frame. Wedges are then driven back of the frame and the frame nailed to the studding.

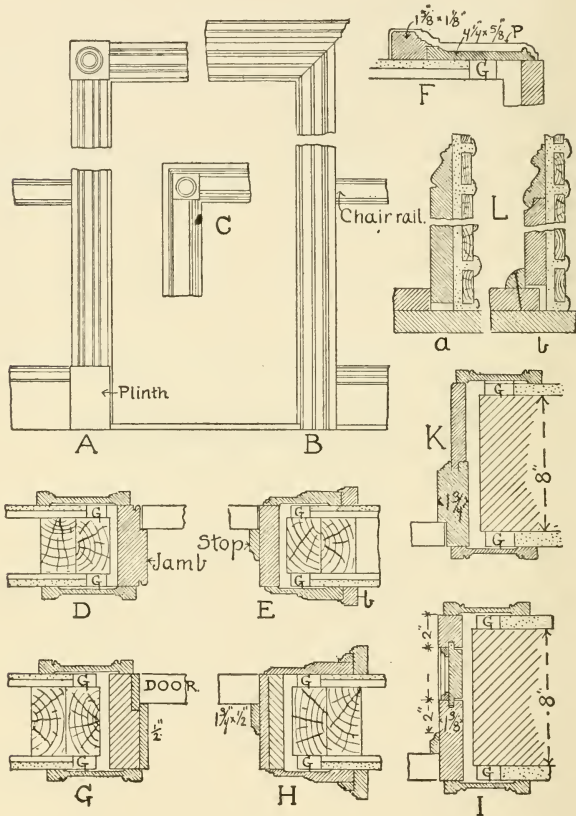

Fig. 234.

In cabinet work the frame should be  $1\frac{3}{4}$  inches thick to permit nailing behind the casing.

The width of the frame should be just equal to the distance between the faces of the grounds, which should be set perfectly plumb.



The grounds should also always be kept a little back from the edge of the studding, so that they will not be disturbed in driving the wedges back of the frame.

*Hard Wood Frames.*—The sections shown at *D* and *E* are for frames of soft wood. If the finish is to be of hard wood the frames should be veneered as shown in sections *G* and *H*, the veneering being  $\frac{1}{2}$  inch thick. If the rooms connected by the doorway are finished in different woods the same woods should be used on the frame, so that when the door is shut the frame will appear to be of the same wood as the finish. If the corner of the frame is to be beaded it will be necessary to veneer the edge of the frame also.

When the frame is made with the stop bead planted on, the entire thickness is often made of hard wood, especially if of the lower priced woods, but the veneered frame will stand better, and when the adjoining rooms are finished in different woods veneering is necessary.

*Panel Jambs.*—When the partitions are 10 inches or more in thickness, as would be the case when built of brick, the door frames should be built up, either in the form of panels, as shown at *I* (called paneled jambs), or in two parts, as shown at *K*; the latter is obviously the cheaper method, but does not look quite as well. If the finish is to be of hard wood the frame should be veneered and the panels and mouldings should be of hard wood. In churches and public buildings a narrow frame is often set on one side of the partition, as in *K*, and the rest of the jamb is plastered, a small moulding being placed in the angle made by the frame and plaster. (See also Section 106.)

*Frames for Double Action Doors.*—For double action doors the frames should be made of a plain board or plank with a hanging strip let into the hanging jamb of the same thickness as the door, as shown in Fig. 235. The other jamb and the head are usually left plain, unless there are double doors, when, of course, both jambs are alike.

*Sliding door frames* are usually made of plain  $\frac{3}{4}$ -inch boards with a moulded strip, similar to a "stop," bradded on each side of the pocket, as shown in Figs. 236 and 257.

**168. Finish.**—The finish on each side of a door opening and also about the window openings is variously designated by the terms *trim*, *casings* or *architraves*. [The term "casing" appears to be the most widely used, and has been adopted by the author. The term "architrave" is frequently used to designate the piece inside of the "back band."]

Various methods of finishing the door openings are also employed. The style of finish shown at *A*, Fig. 234, is termed "block" or "pilas-

ter" finish; square blocks being placed in the upper corners and the casings butting against them. The blocks are usually ornamented by turned rosettes or by carving. In this style of finish any shrinkage in the casings does not show, as they will not shrink lengthways, and, the block being made  $\frac{1}{8}$  inch thicker than the casings, any shrinkage in the block will hardly be perceptible. The blocks are also generally made  $\frac{1}{4}$  inch wider than the casings.

The style of finish shown at *B* is known as "mitred" finish. When mitred finish is used, especially if it is to be varnished, it is absolutely necessary that the wood be thoroughly dry, as any shrinkage in the casings will cause the mitre joints to open very perceptibly. In painted work this can be remedied by putty and another coat of paint, but in varnished work the crack cannot be hidden.

The casings may be composed of one or more members as desired,

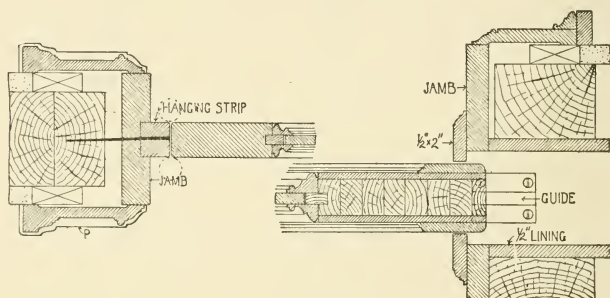

Fig. 235.

Fig. 236.

but if they are to be more than  $1\frac{3}{8}$  inch thick it is better to make them of two or even more members, as shown at *E* and *F*, Fig. 234. There is less chance for shrinkage where two pieces are used and it requires less stock.

In Section *E* the piece *b* is called the "back band," and it is rebated so as to fit over the casing or "architrave" about  $\frac{3}{8}$  of an inch. In varnished work the trim should be built up in this way rather than by simply planting a thin moulding over the casing, as it shows no joint at the back of the casing, and the rebated joint between the two members permits of a slight shrinkage without showing.

At *C* is shown a combination of the block and mitre finish, which is very suitable for ordinary hard wood work. A section of the finish is shown at *F*. The casing is made  $\frac{5}{8}$  of an inch thick by from 4 to

4½ inches wide, and has blocks in the upper corners of the same thickness as the casing. The back band extends around the block and is mitred at the corner. This does away with the mitre joint in the casing and does not look as heavy as the block finish.

Fig. 237 shows another method of constructing a door or window trim. In this case a flat moulding is planted or glued on to the casing and another moulding glued to the outer edge to cover the joint. At the corner the moulded portion of the casing is mitred, but the plain part has a straight joint as shown at *a*. Such a joint will open less, with the same amount of shrinkage, than a mitre joint.

In putting up the finish the architrave or casing should be kept about ¼ of an inch back from the edge of the frame, as shown in the sections.

The design or profile of the door or window finish may be varied to an almost infinite degree, and no especial attempt has been made

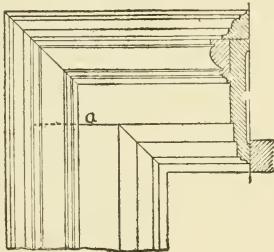

Fig. 237.

in these drawings to suggest mouldings, but merely to show the general methods of using them. Pilaster casings with corner blocks should as a rule have both edges alike. In Fig. 238 a few sections of casings that have been used by various architects are given as a suggestion to the draughtsman. A few designs for cornices or "caps" above the doors and windows are also given. At *A* is shown a simple cap, worked from a single ¾-inch

board, which makes a neat and inexpensive finish. When the picture moulding comes just above the top of the door or window casing, it will look much neater if the head casing is made wider than the others, so that the picture moulding may break over it, as at *C*.

Fig. 239 shows three different arrangements of pilaster casings with cornice. The detail at *B* is from Colonial work. The detail at *C* makes a neat and not very expensive finish, and one that has no mitre joints. The egg and dart mouldings may be machine work.

Fig. 240 shows still another design for a pilaster treatment, after the German style. For very elaborate finish, and especially in public buildings, the pilasters are often terminated by inverted consoles which support the cornice.

In Fig. 241 is shown a mitred casing with the back band broken

at the top, an arrangement quite frequently seen. Fig. 242 shows a heavy pilaster finish with a highly ornamented cornice. These last two examples are from Colonial mansions.

When a heavy pilaster is placed each side of the door or window openings it is generally better to set the pilaster 3 or 4 inches back from the edge of the jamb, with a narrow architrave around the opening, as in Fig. 242.

When the door and window openings are finished with a cornice the appearance of the room and of the wall decoration will be en-

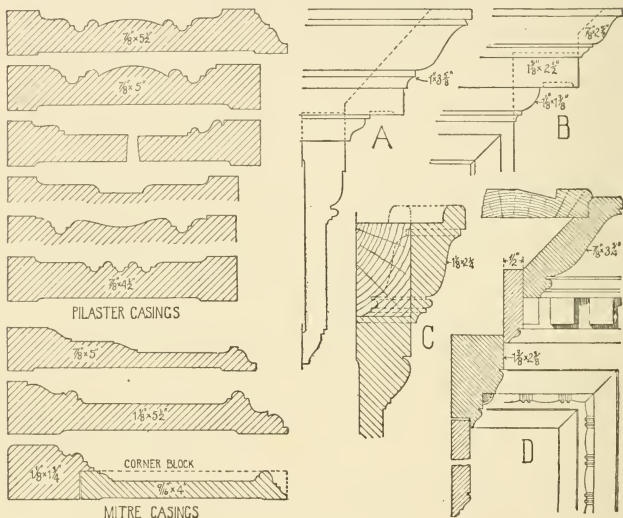

Fig. 238.

hanced if the cornice is on the same level above all of the openings; as the window heads are usually higher above the floor than the door heads, a little different arrangement of the finish is required to bring the cornices to the same level.

Fig. 243 shows a very simple arrangement that the author has used for overcoming this difficulty, with good effect. If the difference in the height of the doors and windows is more than 9 inches, however, it will be necessary to either place a transom over the doors or an ornamental panel, or else let the cornices be at different levels

When the room is wainscoted the draughtsman should not forget to consider how the cap and base is to stop against the door finish. Usually the trim is finished with a wide back band, as in Figs. 236 and 271, but where the cap of the wainscoting is quite heavy, as is often the case in public buildings, it is necessary to place a narrow pilaster or bracket just beside the door trim to stop the mouldings of the wainscoting, as shown in Fig. 275.

**169. Plinth Blocks.**—When the door casing is less than  $\frac{7}{8}$  inch thick the base does not finish well against it, and a “plinth block” should be placed at the bottom of the casing, as shown at *A*, Fig. 234, and also in Fig. 268. This block should be about  $\frac{1}{4}$  inch higher than the base and at least  $\frac{1}{4}$  of an inch thicker than the base or cas-

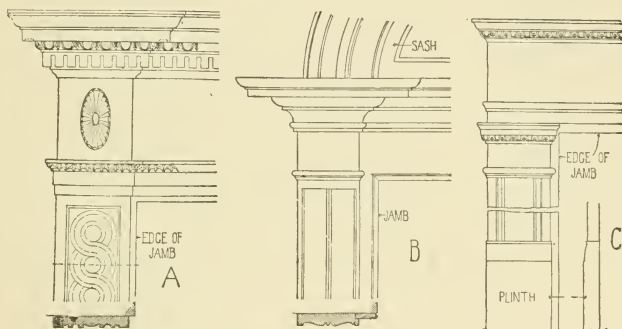

Fig. 239.

ing. With pilaster casings the plinth usually has a plain rectangular section, but with mitred casings the plinth has a section corresponding in outline with that of the casing, as shown at *P*, detail *F*, Fig. 234, and also in Fig. 235. With  $1\frac{1}{8}$ -inch casings or back bands, and a  $\frac{3}{8}$ -inch base, plinths are not necessary and are often omitted, even in the best work, according to the taste of the architect. Aside from stopping the base, however, the use of a plinth block avoids carrying the more delicate mouldings of the casing to the floor, where they are apt to become filled with dirt.

**170. Window Finish.**—The same trim or casing is always used around the windows as around the doors, and when the box or ground casing, or, if there is none, the edge of the pulley stile, is flush with the plaster, the finishing of the windows is exactly the same as around

the doors, except that the window trim usually stops on a "stool." The stool is most frequently made of the shape shown in Figs. 94, 95 and 97, being rebated to set over the wood sill. In the better class of work it is usually  $1\frac{1}{8}$  inches thick, and should be wide enough to stop the casings. Many architects prefer to tongue the stool into the back of the sill about  $\frac{1}{2}$  inch below the top of the latter, as shown in Figs. 96, 98 and 103. When this is done the stop bead is carried across the top of the stool as shown. Where jamb casings are required (see Section 93) the latter method makes perhaps the neatest finish, but in thin walls where there are no jamb casings the author prefers the former method, as it gives a wider stool. Under the stool a moulding or board called the "apron" is always placed to cover the ground or rough edge of the plaster, and also to help support the stool. The apron should be at least  $3\frac{1}{2}$  inches wide.

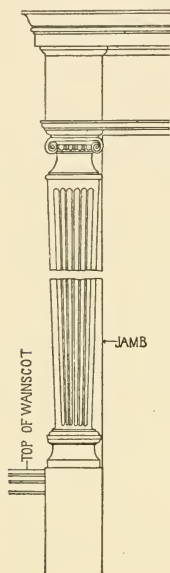

Fig. 240.

When the box casing (see Section 93) does not come flush with the plaster, jamb casings (sometimes called "linings" or "sub-jambs") are necessary to finish between the architrave and the frame, as shown in section in Fig. 98. The jamb casings are usually made of plain boards and the inner edge is generally just flush with the plaster. When a deeper recess is desired, however, the architrave may be set against the back of the jamb casing, as shown at *A*, Fig. 244, but this requires additional grounds, and is not as good a method as the more common one shown in Fig. 98. In a thin wall the stop beads may be brought flush with the casings when greater width is required, as at *B*. If the width of the jamb casing exceeds 6 or 7 inches it will look and stand better if paneled. Very often the jamb casings are splayed, as shown in Fig. 246 (a Colonial example), and occasionally they are moulded their

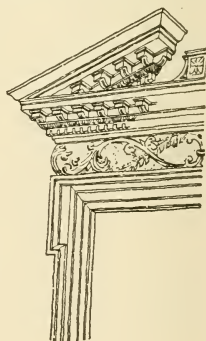

Fig. 241.

full width, as shown in Fig. 245. This finish is especially appropriate to deep mullioned windows.

*Panel Backs.*—In thick walls, whether solid or furred for shutters, the portion of wall between the window sill and the floor is often made of less thickness so as to form a recess to the floor. The inside of this wall is then generally paneled between the jamb casings, although it may be plastered and finished with a base and apron. Windows recessed in this way are said to have "panel backs."

With panel backs the architraves and jamb casings are carried to the floor and finished the same as around the doors. Two very simple panel backs are shown in Fig. 247, while Fig. 246 shows a section and partial elevation of a window with panel back, paneled jambs and inside shutters. The jambs, box casings and stop beads should always be of the same wood as the architrave or casing.

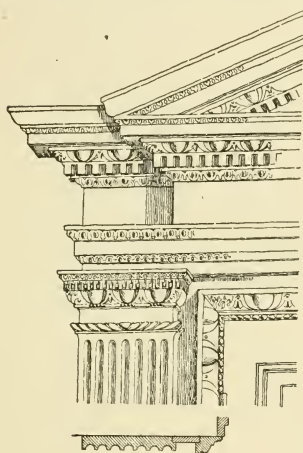

Fig. 242.

#### 171. Putting up the Finish.

—The manner in which inside finish is put up or fixed in place varies with the quality of work desired, and also greatly affects the appearance of the finish, particularly when finished in its natural color. In painted work and ordinary joiners' work the

different parts of the finish are nailed to the wall or grounds and to the edge of the frames with finish nails, which are sunk beneath the surface of the wood for putting. To conceal the nail holes as much as possible, for they cannot be entirely concealed by the putty even when the finish is painted, the nails should be driven in the quirks of the mouldings wherever practicable. Hard wood finish, if nailed, should be bored for the nails to prevent splitting of the wood.

In common work the contractor usually has the finish stuck in pieces of random lengths, 12 or 16 feet, and for the sake of economy is sometimes tempted to "splice" the architraves or casings with short pieces. The appearance of a spliced casing, however, is so bad that it is not considered admissible in good work. To provide

against it the specifications should provide that "no splicing of the architraves or casings will be allowed."

Nail holes in hard wood, even when puttied in the most skillful manner, greatly mar the appearance of the finish, so that in the best grades of work it is generally required that all the members of th

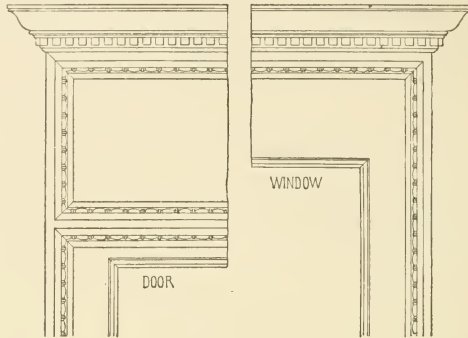

Fig. 243.

door and window trim shall be glued together on the bench and put up with as few nails as possible.

Very frequently the finish is painted on the back and filled, varnished and rubbed before fixing in place. This not only hastens the

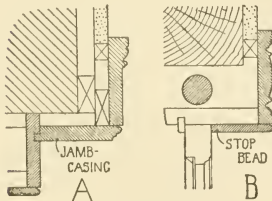

Fig. 244.

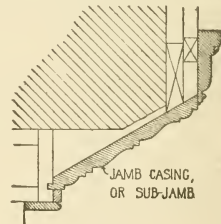

Fig. 245.

completion of the building, but causes the finish to "stand" better, especially the painting on the back. There is also the advantage in having the work finished at the factory, that the wood can be kept perfectly dry and in a room that is free from dust, the varnishers putting on the first coat of shellac as soon as the



woodworker has finished his part. In this class of work the side and head casings are joined together before putting up.

Where block or pilaster finish is used the corner blocks and plinths are secured to the casings by means of dowels, as shown in Fig. 248, glue being used in addition.

Mitred joints are always glued together, and should also have some additional fastening, such as dowels or a "spline." When the trim is composed of architrave and back band, the best construction for the joint is probably that shown in Fig. 249. This is also quite a common joint in the best Eastern work.

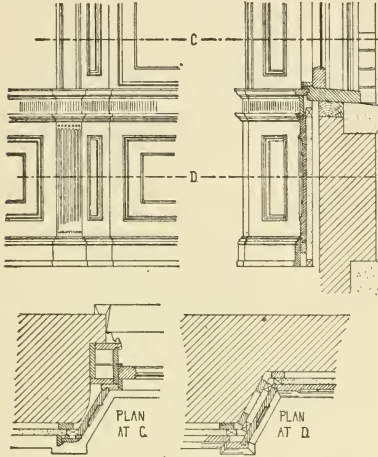

Fig. 246.

After the pieces are mitred the edges forming the joint are grooved and a hard wood strip or spline inserted. The joint is then glued and driven together and two steel mitre brads are driven in from the back, making a very solid joint. When the trim is in one piece the spline should not extend to the outer edge, as it would injure the appearance. Ordinary dowels may also be used in a mitre joint, but they are not as satisfactory as the spline.

In the very best work no nails are used, either in joining the pieces or in setting up the work, the finish being attached to the grounds by means of screws placed back of some loose moulding

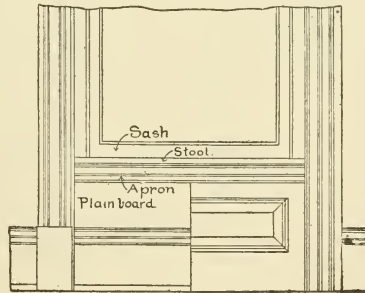

Fig. 247.

or below the finished floor. In this class of work also no large pieces of solid wood are used, the work being made of several pieces glued up, to prevent warping or splitting.

There are several establishments in this country that will in this way make all of the woodwork for the interior of a building in any portion of the globe, ship it ready finished to the building and send men to put it up, which latter work requires but a very short time.

Such work as the above is necessarily expensive, but it is sure to stand well and give satisfaction, and should always be specified when the best work is desired.

**172. Inside Shutters.**—At one time inside shutters were considered as one of the necessary fittings of a fine dwelling, and when

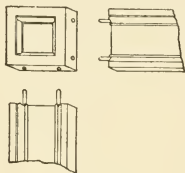

Fig. 248.

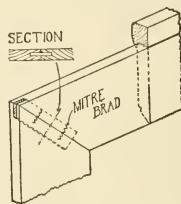
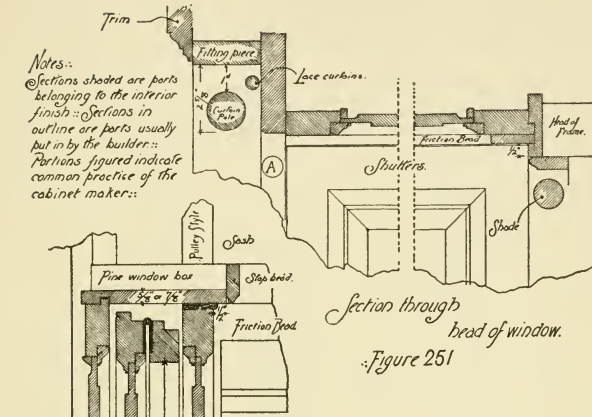

Fig. 249.

they are properly arranged they are very serviceable. When they interfere with the proper trimming of the windows by shades and draperies, however, they are more objectionable than desirable. When used in rooms that are to be nicely furnished, the jambs of the windows should therefore be made of sufficient depth, by furring the walls if necessary, that pockets may be provided for the shutters to swing into when open, and the arrangement of the finish should be such that when the shutters are folded back they will appear as a paneled jamb. To obtain the best effect the window should have a panel back, with paneled jambs to the floor.

Figs. 250 to 252, taken from an excellent article on "Interior Woodwork," by Mr. A. C. Nye, and published in the *American Architect* of January 23, 1892, show what is probably the most complete and desirable arrangement for inside shutters in dwellings. The different folds of the shutter should be hung so that they will all swing in the same direction, the middle leaf always occupying a position near the centre when the shutters are folded in the box. It is believed that this method of hanging cures the tendency that shutters have to spring out of the box.

Notes:  
 Sections shaded are parts belonging to the interior finish:: Sections in outline are parts usually put in by the builder:: Portions figured indicate common practice of the cabinet maker::



Section through head of window.  
 ..Figure 251

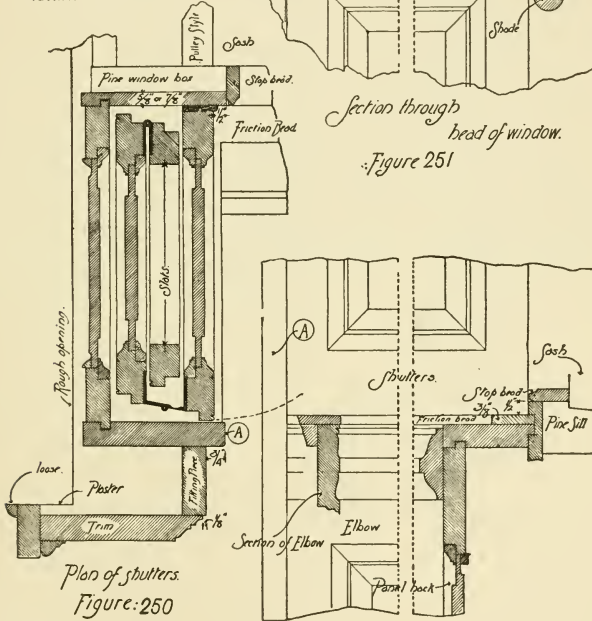

Plan of shutters  
 Figure: 250

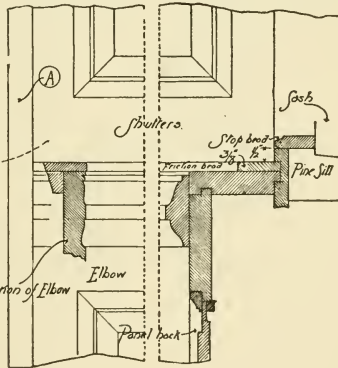

Section through window stool.  
 ..Figure 252

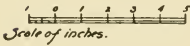

..ACN del.

One feature which may be noticed in Figs. 251 and 252, and which should always be provided, is that the top of the shutter is not carried to the soffit of the window, but is separated by a  $\frac{1}{4}$  or  $\frac{3}{8}$ -inch bead, and the bottom is similarly treated on the elbows and seat.

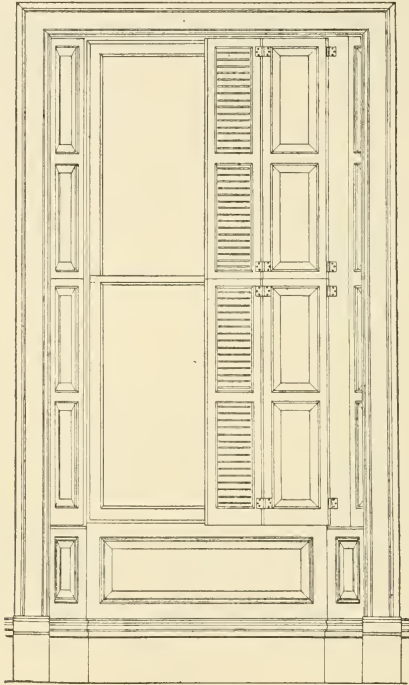

Fig. 253.

In laying out the drawing for the window, how and where the curtain poles are to be placed should be considered.

If they are to be set on the outside of the trim the casings may be set as close to the shutter box as the thickness of the wall will permit. If, however, it is desired that the curtain be kept inside the trim, or if the shutter box does not project sufficiently to clear the

plaster line of the wall, a fitting piece must be used, as shown in Figs. 250 and 251, and the curtain poles fastened to it. Should the fitting piece be wide enough to receive both the heavy pole for the drapery curtains and the small pole for the lace curtains the latter is placed directly behind the former. When the curtain poles are placed on a level with or a little below the soffit of the window light shows above them. To avoid this the fitting piece across the head should be kept  $2\frac{5}{8}$  inches above the soffit of the window and the poles placed as in Fig. 251.

When it is desired to reduce the thickness of the wall, the jambs may be splayed, as shown in section in Fig. 254, and in elevation in Fig. 253. The window finish may also be brought forward into the room if furring is objectionable, as shown in Fig. 257.

Where lace curtains or draperies are not considered necessary, the

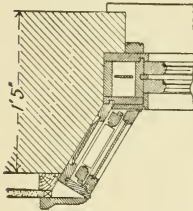

Fig. 254.—Curtain Pole.

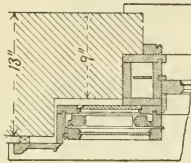

Fig. 255.

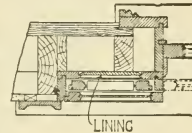

Fig. 256.

shutters may be arranged to fold back against a pocket in the face of the wall, as shown in Figs. 255 and 256. There are also numerous other arrangements that may be provided for shutters, but those illustrated appear to the author to be the best. The shutters themselves should be framed and paneled with rails and stiles  $1\frac{1}{8}$  inches thick (although sometimes made  $\frac{3}{4}$  inch or  $1\frac{1}{16}$  inches thick). They should be divided into at least two sections in height, as in Fig. 253, so that either the upper or lower half of the window may be closed at will. When the window is more than 6 feet high it is desirable to have three or four sections. Each section is also made in *folds* or leaves, usually four folds to windows 3 feet or less in width, and six folds for wider windows.\* The outer or hanging fold should always have solid panels, but the inner folds, especially in the upper section,

\* A fixed rule with certain manufacturers is that the minimum width of any fold shall be 6 inches and the maximum width 12 inches; the most desirable width seems to be between 8 and 9 inches.

are usually fitted with rolling slats. In the best blinds the rolling slats do not have a rod in front, but are fitted with metal bars at the ends, which cause them to work better and take up no space. Fig. 258 shows the standard section (one-half full size) of stiles and panels as made by the Willer Manufacturing Co. The folds should be hung so as to fold back in the manner indicated in the drawings. [For description of the hardware of trimmings see Chapter VI.] Shutters are usually made of the same wood as the finish of the room, although occasionally a different kind of wood is used. Better shut-

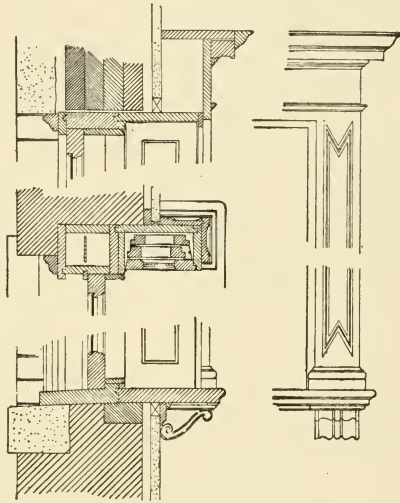

Fig. 257.

ters will generally be obtained by buying of parties that make a specialty of their manufacture.

**173. Sliding Blinds.**—Besides the folding shutters described in the preceding section, there are three other styles of inside window blinds, viz., sliding, rolling and Venetian, that are more or less used in place of shutters or cloth shades, and with which the architect should be familiar.

*Sliding blinds* are made in vertical sections to slide up and down between the jambs of the window in the same way as the sash. The

blinds may operate within the height of the window or they may run into a bottom pocket, or into a top pocket, or into both a top and bottom pocket, so that the window can at any time be either wholly or partly uncovered by the blinds.

The different sections operate independently of each other, each sliding by the others, so that any section may be raised or lowered without uncovering the other portions of the window.

The sections may be balanced by weights or held in place by springs that press against the guides or runways. For narrow windows the springs answer very well, but when the blinds are more than  $3\frac{1}{2}$  feet wide it is much better to balance them by weights, and balanced blinds will probably give better satisfaction even in narrower windows.

The number of sections to be used in any given window will depend upon the height of the window and the amount of money that can be expended, the cost increasing with the greater number of sec-

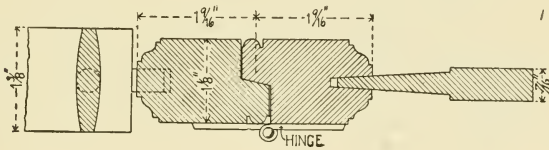

Fig. 258.

tions. For windows between  $4\frac{1}{2}$  and 6 feet in height three sections are recommended, and for windows over 6 feet in height four or six sections will give the best satisfaction. The total height of the sections should be such that the entire window between the sill and head may be closed, allowing the sections to lap over each other about 1 inch.

Each section should be divided into a number of divisions or panels, which should be between  $6\frac{1}{2}$  and  $9\frac{1}{2}$  inches in width, measured between the centres of the stiles. These divisions may be filled with panels or slats in any arrangement desired.

To use sliding blinds to the best advantage and without sacrificing the appearance of the window, the window frames or inside finish should be made to accommodate the kind of blind selected, as special arrangements are necessary for the runways, and in fine dwellings pockets should be provided for the blinds to shut into when not in use. When the wall is thick enough the best appearance will usually

be obtained by having a panel back between the casings and letting this form the front of the pocket for the blinds.

In chambers, school rooms, offices, etc., the pocket may be dispensed with, as by using three sections two-thirds of the window can be uncovered, which is usually all that is necessary, and the appearance of the blinds is not in such places objectionable. The usual thickness of sliding blinds is  $\frac{5}{8}$  inch, although they are made  $\frac{1}{2}$  inch

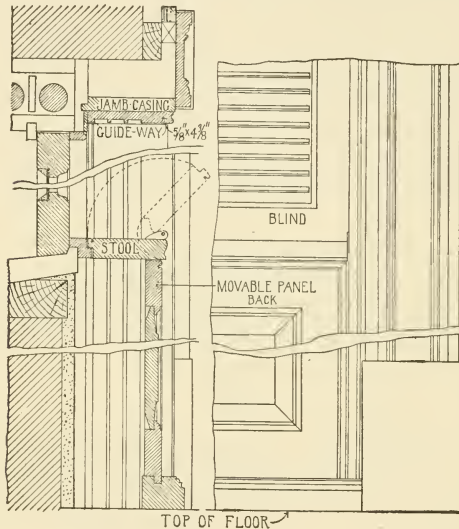

Fig. 259.—Detail for Sliding Blinds.

and 1 inch in thickness. The sections slide in a grooved runway, which should preferably be secured to the jamb casings or take the place of them, and in such a way that the stop beads for the sash may be removed without disturbing the runways.

Fig. 259 shows what is perhaps the best arrangement for inside sliding blinds of three sections, the sections all sliding into a pocket behind the panel back and a hinged stool being provided to cover the pocket when the window is uncovered. Four sections may be arranged in the same way by providing for an additional groove in the runway.



This detail is applicable to all makes of sliding blinds that are held in place by springs at the sides, although some makes may require a greater space between the grooves in the guideway. Weight-balanced blinds may also be fitted in the same way, but for these the pockets for the weights are generally placed in the guideway. Fig. 260 shows a section of the guideway as used with Poppert's weight sliding blind and the manner of applying where the window has a sub-jamb. In this detail the blinds stop on the stool; if a pocket beneath the stool is desired, the guideway should be extended to the floor and a panel back and hinged stool provided, as in Fig. 259. The Poppert blinds do not run in a groove, but are guided by ornamental metal guides, which run in narrow grooves in the guideway as shown.

When sliding blinds are used in frame buildings or in brick buildings with 9-inch walls, it is generally necessary to place the guideway against the pulley stile, allowing it to take the place of the stop bead,

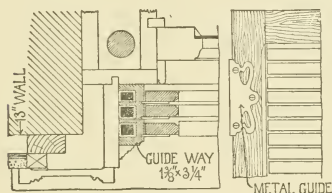

Fig. 260.—Poppert's Weight Sliding Blind.

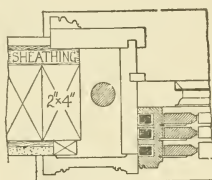

Fig. 261.

as shown in Fig. 261. In 9-inch brick walls, and often in old frame buildings, it will be necessary either to box out the casings or to project the guideway beyond the casings.\*

In new buildings the guideways should be put up when the building is finished, but the blinds themselves may be put in or removed at will. Sliding blinds may be made at any woodworking shop, but much better blinds for the same amount of money will be obtained by purchasing of those who make a specialty of them, besides obtaining better trimmings than one would be likely to get elsewhere.

**174. Rolling Blinds.**—These are made of slats strung on wires or ribbons so that they may be rolled on a coil placed in a pocket above the window head, the slats running in a groove at each side to keep them in position.

\*Details showing the construction of the guideway and finish for a great variety of arrangements will be found in the large catalogue of the Willer Manufacturing Co.

The slats are so arranged that air and light are admitted and a view from within can be obtained, although they cannot be seen through from without. They are made of various woods to match the standing finish.

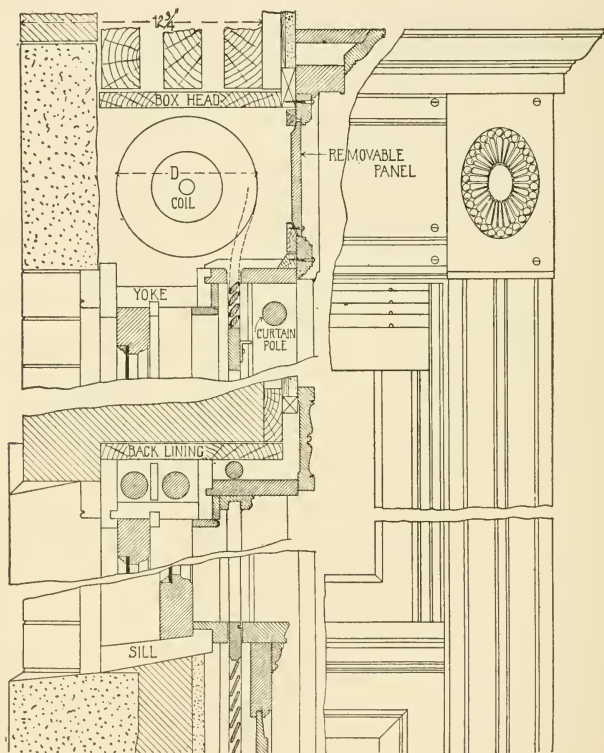

Fig. 262 —Detail for Rolling Blinds.

Rolling blinds do not require as deep a recess for the window as sliding blinds or shutters, but in frame walls with less than 8-inch studding it will be necessary to box out for the coil either inside or outside of the window. A single section of sliding blind fitted with

movable slats is sometimes used at the bottom of the window in connection with the rolling blind, the sliding section being arranged to drop into a pocket behind the panel back. This shortens the rolling portion and reduces the size of the coil.

Fig. 262 shows a section through the jamb, head and sill of a window in a 12-inch brick wall, fitted with Wilson's Rolling Venetian Blind, with the coil placed in a pocket behind the stone lintel, and a sliding section at the bottom. When it is not practicable to place the coil in the wall it may be enclosed in an inside cornice placed above the window.\*

The diameter of the coil,  $D$ , with the blinds rolled up, is 7 inches for a 5-foot blind;  $7\frac{1}{2}$  inches for a 6-foot blind, and  $8\frac{1}{2}$  inches for a 7-foot blind.

Provision should be made so that the casing in front of the coil may be readily removed for oiling the bearings, and it is desirable that the whole front of the box be put up with screws so that the coil can be set in place after the finishing is done or may be removed at any time. By framing the rails of the top panel, Fig. 262, into the corner blocks and putting the latter up with screws, the whole front of the pocket may be readily removed, while the joint will not be perceptible when the finish is in place.

Rolling blinds have been quite extensively used in very fine residences, and are preferred by many to other styles of blinds, but to secure the best results they should be arranged for when the building is built. They are patented, and can only be obtained from one or two manufacturers.

Rolling blinds may also be fitted to work outside of the sash, and may be made of steel as a protection from burglars.

**175. Venetian Blinds.**—The common or English type of Venetian blind consists of a series of thin wooden slats 2 or  $2\frac{1}{2}$  inches wide, arranged laterally in woven ladder tapes, suspended from the top and connected by cords which raise or lower the slats or tilt them as desired. It is practically a window shade hanging free, but made of wooden slats instead of cloth.

This blind is very extensively used in England and on the continent of Europe, and to a considerable extent in this country. It possesses an advantage over all other types of wooden blinds in that it may be easily fitted to any window, although it can be used to better advantage in windows having sub-jambes. The admission of

---

\* Details and descriptions of various arrangements for enclosing the coils will be found in the catalogue of James Godfrey Wilson, New York City.

light and air is almost perfectly regulated and controlled, as part of the slats may be opened while the others are closed, or the blind may be drawn up so as to uncover the larger portion of the window. [When drawn up a blind 7 feet high will take up a space of about 11 to 12 inches with 2-inch slats, and 10 to 11 inches with  $2\frac{1}{2}$ -inch slats.]

The common form of Venetian blind is made by several manufacturers in this country, and the general appearance, construction and manipulation is much the same in the different makes, the variations being in the method of hanging and applying to the window and in the quality of the materials and workmanship.

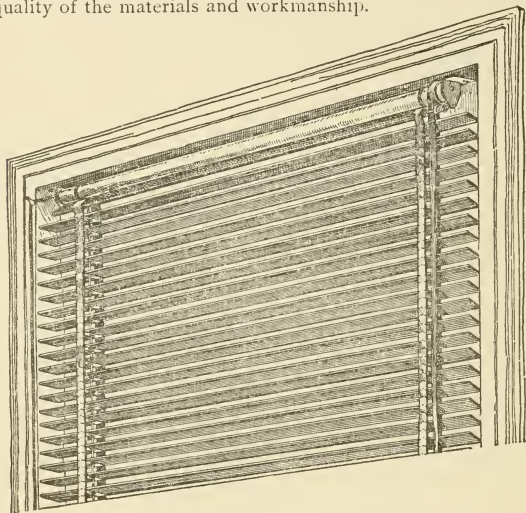

Fig. 263.—Wilson's Venetian Blinds, Showing Roller.

For the best blinds metallic ladders, hinged to shut up like the tape, are used, being more ornamental, and, it is claimed, more durable. In the manner of fixing the blind to the window finish each manufacturer has a special method. Thus the Victoria blind, Fig. 264, has a flat head piece 2 inches wide, which can be screwed to the stop bead at the top of the window when the latter is  $1\frac{3}{8}$  inches wide, or to the under side of the head casing, where there are sub-jambs. It may also be fastened to the face of the window casings by small brackets.

Most Venetian blinds, however, have a roller or rocking bar at the

top, of which one make is shown in Fig. 263, and to this roller or bar the cords for raising or tilting the slats are attached. These bars are usually attached only at the ends, which fit into sockets or hangers screwed to the side of the sub-jambs or to blocks set against the pulley stiles.

One make, "The Burlington," has sockets very much like those used for cloth shades, and which can be put up either on the stop beads, jamb casings or on the face of the casings.

The best methods of putting up Venetian blinds, however, of any make, are those shown in Figs. 265-267. In residences where there are sub-jambs it is well to form an open pocket behind the head casing, so that the rocking bar will be concealed and also to lessen the exposure of the blinds when drawn up. In other buildings this is not essential. The width, *W*, varies with different makes of blinds, 3 inches being usually sufficient for 2-inch slats, although a space of  $4\frac{1}{2}$  inches is much better, as a narrower space is apt to wear the tapes. In frame buildings and in 9-inch brick walls the method shown in Fig. 267 is believed by the author to be the reatest, unless a pocket is desired. By this method a block *B*, about  $\frac{5}{8}$  inch thick, is

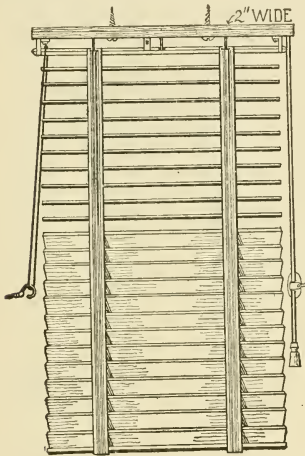

Fig. 264.—Victoria (Venetian) Blinds.

scREWED TO THE FACE OF THE pulley stile next to the inner sash, and the stop beads are cut against it. If the distance from the sash to the edge of the pulley stile is less than that shown in the drawing, the block may be allowed to project, as shown by the dotted lines, the blinds hanging free like a cloth shade; it is not necessary that they come between the stop beads. The dimensions given in Figs. 265 and 267 are for the Willer Venetian Blinds with 2-inch slats, *R* showing the position of the rocking bar. Fig. 266 shows the roller of the Wilson blinds.

Besides the common or English type, there are variations in the way of sliding Venetian blinds, in which the bottom piece slides up

and down in grooved runways attached to the jamb casings, and also a type in which the blind is balanced by weights, the action of the blind in other particulars being practically the same as in the common type.

**176. Selection of Inside Blinds.**—When making a choice of inside blinds for a given building the special advantages of the different kinds and the adaptability to the depth of the window and the character of the room should be carefully considered, and also the preference of the owner. For controlling the admission of light and air, there does not seem to be much choice between the sliding blind with movable slats and the Venetian blind, both of which are superior in these respects to shutters. On the other hand shutters afford a better protection from cold, and with thick walls they are

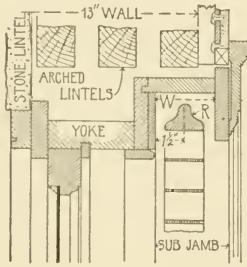

Fig. 265.

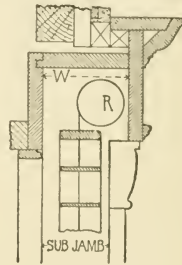

Fig. 266.

susceptible of a neater arrangement of the finish, and in dwellings, particularly, the appearance of the window from the inside is a very important consideration.

*The comparative cost of the different types of blinds for a window of average size (sash, 3x6½ feet), natural pine finish, is about as follows, considering the blinds alone and without regard to the cost of the frame or finish :*

Folding blinds, raised panels and patent movable slats.....	§ 7.50
Common folding blinds.....	6.00
Best quality of sliding blinds (with springs).....	7.50
Rolling blinds (Wilson's).....	10.00
English Venetian blinds.....	4.00
Willer's Favorite Sliding Venetian Blind.....	7.00

It should be remembered, however, that it will cost more to fit up the window for folding shutters, that is if paneled pockets are provided, than for either of the other kinds of blinds.

**177. Base or Skirting.**—In this country the board commonly placed around the walls of rooms just above the floor is more commonly designated as the “base,” although the English term “skirting” is used in some localities. When the base is not more than 8 inches wide it is generally made of a single board with the upper edge moulded, as at *a*, detail *L*, Fig. 234. When the height of the skirting, including the moulding, is more than 8 inches it is better construction to have the moulding stuck from a separate piece, as shown at *b*, Fig. 234, the moulding being rebated to fit over the top of the base. Bases 10 inches wide, however, are often made in one piece, as in Fig. 268. When the skirting is in more than one piece, the wide part

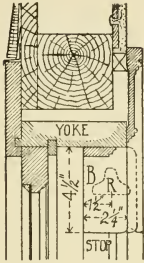

Fig. 267.

is called the “base” and the top member the “base moulding.” Quite often the skirting is made 18 or 20 inches wide so as to form a sort of wainscot. In such cases it should be made in three parts, as shown in Fig. 269, the top member or surbase intersecting with or being coped to the

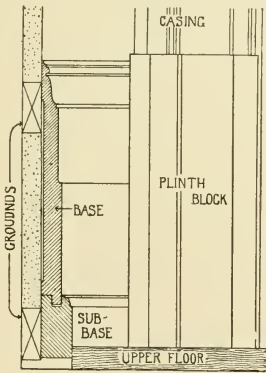

Fig. 268.

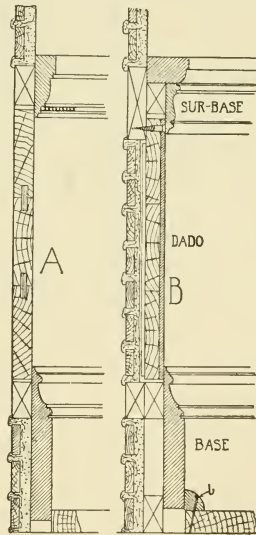
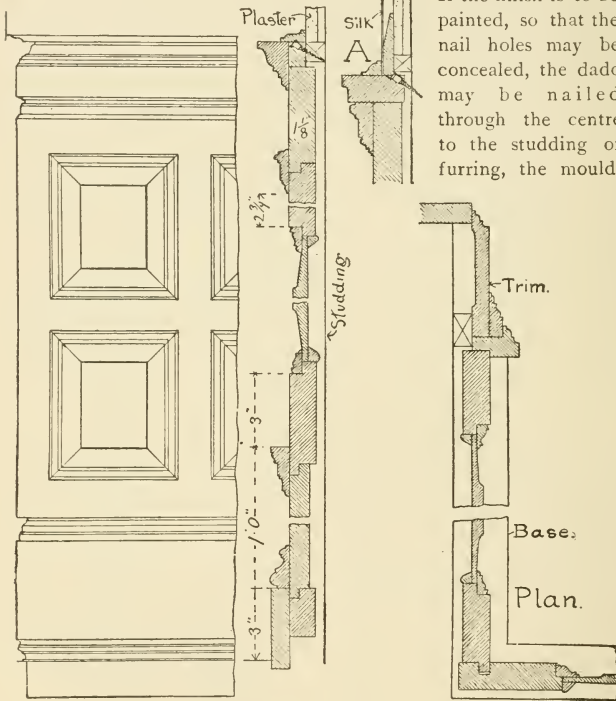

Fig. 269

window stool and apron, if they are the same height from the floor. The dado may either be placed between the grounds, as at *A*, or

outside of the plaster, as at *B*. For fine hard wood finish the construction shown at *B* is believed to be the best, the dado being built up with a pine backing keyed on the back side and veneered with the finish wood. It should be attached to the grounds only at the top, so that it may shrink or swell without cracking. It is a dangerous proceeding to fasten a wide board both at the top and bottom.



If the finish is to be painted, so that the nail holes may be concealed, the dado may be nailed through the centre to the studding or furring, the mould-

ings at the top and bottom being depended upon to hold the edges in position.

There are two methods of putting on the base: the first is to put on the base before the upper floor is laid, the bottom of the base being  $\frac{1}{2}$  inch below the top of the upper floor, so that if any shrinkage



takes place it will not leave an open joint at the angle. Another method is to keep the bottom of the base about  $\frac{1}{8}$  inch above the top of the upper floor, and put a quarter round or other moulding in the angle, as shown at *b*, Fig. 269. This moulding, or "carpet strip" as it is called, should be nailed to the floor, and *not* to the base, so that the base may shrink or the floor settle (owing to shrinkage in the floor timbers) without raising the moulding or splitting the base. When there is only a single floor it is necessary to use the "carpet strip," as the flooring cannot well be laid against the base. Where there is a double floor the former method is probably the best, although the carpet strip is often used, especially in the West.

A still better method of construction is that shown in Fig. 268, where a sub-base is used. The advantage of this method is that the sub-base can be put down perfectly straight and thus form a guide for the base. To avoid splitting if the wood shrinks, the base should be nailed only at the top.

Every room and closet, unless wainscoted, should have a base of some sort.

**178. Wainscoting.**—This term is commonly used to designate a wood or marble lining, or covering of the inside walls, whether of paneled work or of plain matched boarding. The wainscoting may be made any height that is desired, but the most common height for living rooms is from 2 feet 8 inches to 3 feet. Halls and bathrooms are often wainscoted to a height of 4 feet or 4 feet 6 inches. Behind the kitchen or pantry sink the wainscoting should be at least 5 feet high to receive the plumbing.

Some kinds of wainscoting are especially desirable in kitchens, bathrooms, back stairways, etc., as a protection to the walls. Paneled wainscoting is usually considered as especially appropriate for front halls, libraries and dining rooms, and in the principal rooms of most public buildings.

*Paneled wainscoting* may be arranged in almost innumerable ways, but the method of putting together is or always should be the same. It always should be got out and put together in the shop in lengths as long as can be conveniently handled. Thus one piece will extend from the mantel to the adjoining corner of the room, or the space between two door or window trims will be filled with one piece. When it is possible to do so these sections should be rebated into the finish of the doors, windows, etc., and the angles should be tongued together. The plan, Fig. 271, shows the way in which this should be done.

The wainscoting is sometimes set outside the plaster, but often the lath and plastering are omitted back of the wainscoting or the plastering is done between the studding, so that the wainscot shall not have so great a projection. If the wainscot sets outside of the plastering the projection of the cap will be 2 or 3 inches, necessitating a very heavy door and window finish. On outside walls, however, whether of brick or frame, the plastering should always be carried to the floor behind the wainscoting. On brick walls the plastering may be applied between the furring strips, and on frame walls cleats may be nailed to the sides of the studding so that the plaster will be flush with the face of the studs; this, however, involves some additional expense.

In the section and plan shown in Figs. 270 and 271 the plastering

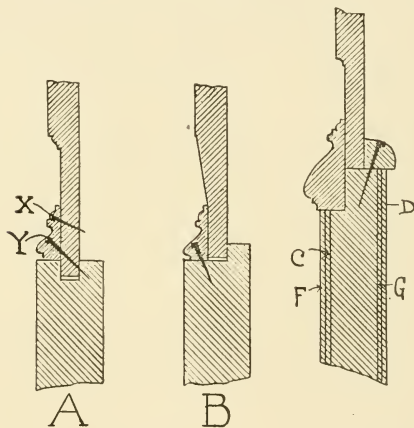

Fig. 272.

Fig. 273.

is stopped by a ground placed just back of the cap. As the wainscoting is glued together and often varnished before it is set up, it is impossible to bend it to fit any irregularities in the walls, and hence it is usual to allow of a space of  $\frac{3}{8}$  inch between the back of the paneling and the plaster or studding. The wainscoting should be fastened in place by screws put in from the top and beneath the floor line or behind the carpet strip. At the top should be a small, loose moulding that can be put on after the paneling is fixed in place and "scribed" to the wall. The usual thickness of the stiles and rails is  $1\frac{1}{2}$  inches.

Fig. 270 shows a vertical section and part of the elevation of wainscoting, 4 feet 6 inches high, set against the studding. This particular wainscot has a neck and a base 15 inches high.

If the wall above the wainscot is to be covered with silk or tapestry a pine slat from  $\frac{1}{8}$  to  $\frac{3}{8}$  inch thick is nailed to the plaster, as shown at detail *A*, Fig. 270, and on this slat the silk is tacked.

**179. Paneling.**—The ordinary joiner's method of making paneling is shown by *A*, Fig. 272, a groove being worked in the stile and the moulding being nailed to both the stile and the panel. If the nail is driven as at *Y*, neither the panel nor the moulding can move when shrinkage takes place, consequently the panel cracks. If nailed into the panel and not into the stile the shrinkage of the panel causes an opening to appear between the stile and the moulding unless the moulding is "raised" and rebated over the stile. A better method of making the paneling is shown at *B*. In this construction if the moulding is nailed into the stile and rail, without penetrating the panel, the panel is loose and can shrink without damage. If glue is used to hold the moulding, however, this method becomes as bad as the first.

Fig. 273 shows the cabinet maker's method, by which almost a perfect piece of work may be secured. In this method a rebate is first cut in the rail on the finish side. In this the moulding is *glued* solidly so it practically becomes a part of the rail. When the glue is dry the *varnished* panel is set in from the back and held in place by strips nailed to the rail. This leaves the panel loose and free to move should shrinkage take place. All first-class wainscoting should be built in this way.

In very fine cabinet work the panel frame would be veneered, as shown in Fig. 273, *C* being the mahogany or other choice wood veneer, *D* oak veneer, *E* the core, which may be of ash, pine or chestnut, and *F* and *G* oak veneers of the same thickness as the veneers *C* and *D*, but with the grain of the wood running at right angles to that of the core and the outer veneers. The core itself is also built up of  $\frac{3}{4}$ -inch strips glued together. The veneers used in this class of work do not exceed  $\frac{1}{8}$  inch in thickness.

**180. Matched Wainscoting.**—In kitchens, back halls, stores, school rooms, etc., the walls are often wainscoted or "ceiled" with matched boards, which are generally beaded on the edge and sometimes in the middle of the board. For good work this "ceiling,"\*

\*In some of the Eastern States called "sheathing."

as it is called, should be worked out of 4-inch or 3-inch boards, showing about  $3\frac{1}{4}$  inches or  $2\frac{1}{4}$  inches on the face. The ceiling is blind nailed in the same way as matched flooring, being put up one piece at a time, and generally extends to the floor, without a base. The cap moulding is often rebated to fit over the top of the ceiling. When the walls are to be ceiled in this way grounds must be put on

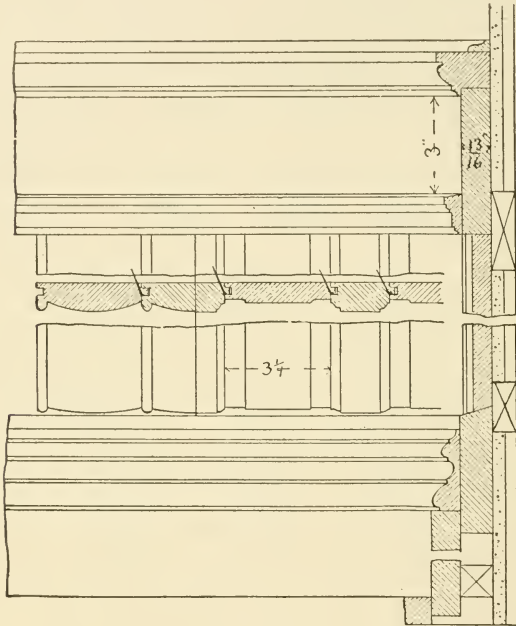

Fig. 274.

the studding, if the ceiling is to be set outside the plaster, to receive the nails. If the ceiling is set flush with the plaster bridging must be cut in between the studding for the same purpose. When something handsomer than beaded wainscoting is desired, and paneled work can not be afforded, moulded ceiling or sheathing may be used. The ceiling can be moulded to any pattern, and, if desired, the alternate pieces may be of a different pattern. Fig. 274 shows a section of a moulded wainscot and also one with two patterns alternating;

the latter arrangement may be designed so as to somewhat resemble paneling. When wainscoting such as this is used with a base moulding it will not do to simply nail the base against the wainscoting, as this would leave spaces between the base and the sunk portions of the ceiling, which look very bad and soon fill up with dirt. The proper construction is to stop the ceiling on a beveled board about  $\frac{1}{8}$  inch thicker than the ceiling and set about  $\frac{1}{2}$  inch above the top of the base, as shown in the section. Above the cap moulding it is a good idea to place a small

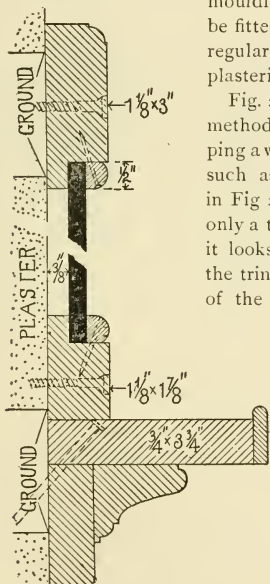

Fig. 276.

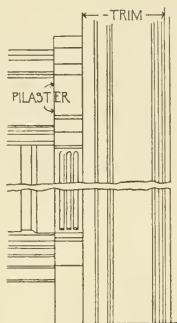

Fig. 275.

moulding that may be fitted to any irregularities in the plastering.

Fig. 275 shows a method of stopping a wainscoting, such as is shown in Fig. 274, at the door openings where only a thin casing is used. In dwellings it looks better to make the projection of the trim sufficient to stop the mouldings of the wainscot, as in Fig. 271, but in

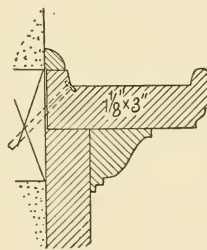

Fig. 277.

large buildings of a semi-public character the small pilaster looks very well and is much cheaper.

In school rooms fitted with blackboards the top of the wainscot is usually fitted with a shelf to receive the chalk and erasers, of which

two details are shown in Figs. 276 and 277. Fig. 276 also shows the manner in which slate blackboards should be fastened to the wall.

**181. Chair Rail.**—In dining rooms, and sometimes in halls that are not wainscoted, a moulding 4 or 5 inches wide is often carried around the room at the right height to receive the top of a chair back (about 3 feet 2 inches to centre.) This moulding is called a chair rail. It may be worked from a single board or be built up of two or more members, but the designer should always consider how it will stop against the door and window trim.

*Picture Moulding.*—It is now customary to specify a picture moulding to be put around all rooms in which pictures are likely to be

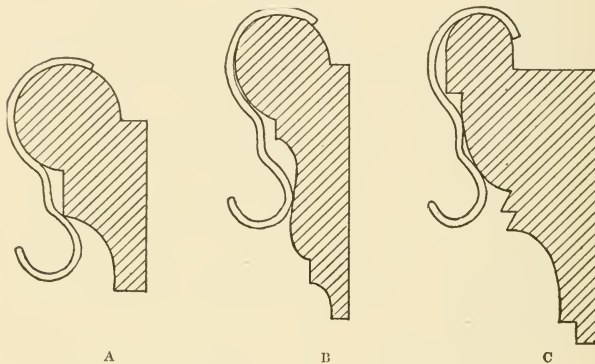

Fig. 278.—Picture Mouldings, Full Size.

hung, and mouldings for this purpose are carried in stock by the larger lumber dealers, the common pattern being shown at *A*, Fig. 278.

In the better class of work the picture moulding is generally designed to correspond with the other finish, but should be of a section that the ordinary picture hooks will fit. At *B* and *C*, Fig. 278, two sections are given as suggestions to the draughtsman. The moulding should be of the same wood as the standing finish, unless it is to be made a part of the wall decoration.

*Mouldings with Space for Wires.*—In office buildings it is a good idea to make provision for running telephone or telegraph wires, bell wires, etc., within a moulding placed near the top of the room. Where the hall partitions contain windows with transoms over the

doors, the heads of the door and window frames may be kept on a level and a moulding, similar to that shown in Fig. 279, run the whole length of the halls in place of a head casing, the side casings stopping under it.

*Angle Beads.*—When projecting angles have a plaster arris or edge it is customary to protect the angle by a turned bead, with a quarter cut out to fit over the plaster, as shown in Fig. 280. Angle beads are usually of the same wood as the standing finish, and from  $1\frac{1}{4}$  to  $1\frac{3}{4}$  inches in diameter and about 4 feet 6 inches long. Sometimes flat mouldings, similar to an O. G. stop, are nailed each side of the angle, as they afford better protection for the corner, but the turned bead is generally used in residences. Angle beads can hardly be considered as an ornament to a room, and the author much prefers the use of metal corner beads, which render the angle bead unnecessary.

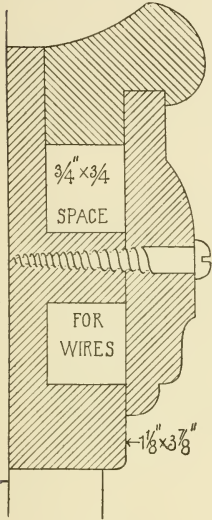

Fig. 279.

the best class of work they are glued together in long sections before putting up, being stiffened where necessary by pine blocks glued to the back of the cornice. To make a good job grounds should be put on the walls and ceiling before plastering at the proper place for nailing the upper and lower members.

When the cornice is glued together before putting up the moulding next the ceiling should be left loose, to be nailed on after the cornice is set in place.

Figs. 281 and 282 show two different styles of cornices. In the former the picture moulding is placed close under the cornice, of which it apparently forms a part. Attention is called to the way in which the dentils are made in Fig. 282. Instead of each dentil being

**182. Wooden Cornices, Ceiling Beams, Columns, etc.**

*Wooden cornices* are often used in the principal rooms of dwellings, and if without carving they cost about the same as plaster cornices. They should be put up after the plastering is thoroughly dry, and in



Fig. 280.

a separate piece they all form a part of the piece marked *a*, the spaces between the dentils being cut out. This insures against the dentils dropping off.

*Beams.*—The beams seen on the ceilings of dwellings are not usually solid, as they appear, but are a mere shell of thin stuff tongued and grooved together. Around the room is usually placed a half beam or cornice into which the principal beams are framed, and the smaller beams are in turn framed into the principals, as shown in Fig. 283, the side member of the small beams being usually, although not always, continued on the side of the larger beams. When made by cabinet makers the entire ceiling is often put together on the floor and raised in position against the plaster ceiling, where it is fastened.

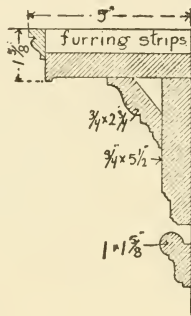

Fig. 281.

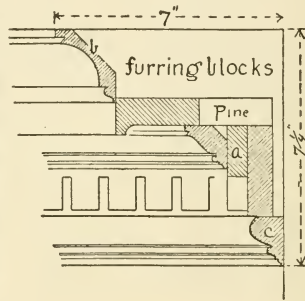

Fig. 282.

When put up by joiners most of the work is built in place, the beams themselves being usually glued together in lengths at the shop and put up separately. Whichever way they are put up the architect should require that grounds be put on the ceiling for securing the beams, as shown in Fig. 283, and for nailing the panel mould.

As the beams are hollow some method of strengthening them at the intersections is needed. Cabinet makers usually set in a pine block the full depth of the beam inside and sufficiently long to have strength when mortised out to receive the end of the beam tenoned into it. The end of this latter beam is also strengthened by a similar block on which the tenon is cut.

The outside or show wood should be mitred where the joint is made. In addition to the blocks placed at the points of intersection, others should be placed at intervals of about every 2 feet to give



stiffness to the whole structure. The moulding surrounding the panels between the beams should be left loose and set after the beams are in place, as also the moulding below the wall beams. The panels may be of plaster or wood; if of the latter they should be put together and finished in the shop and raised in position after the beams are up, and the loose moulding then nailed in place.

When the bottom of the beams are paneled, as in Fig. 283, pieces should be put in at the ends and intersections of the beams to form the end of the panels, as shown in Fig. 284, which represents a plan of the intersection of the smaller beams.

Sometimes the finished beams enclose solid beams which form a

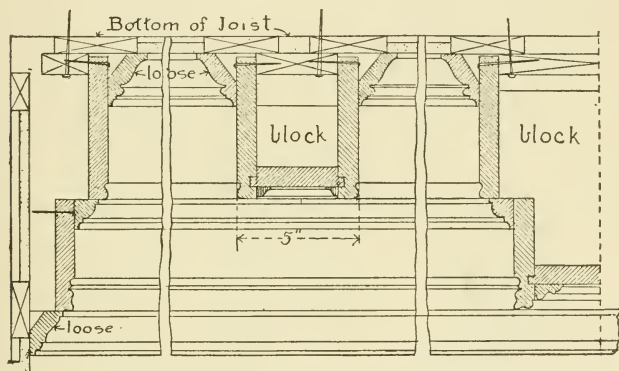

Fig. 283.

part of the floor construction, in which case it is generally necessary to build the beams in place. It is always better to put ceiling beams together in the shop, however, as much as possible.

Fig. 285\* shows how the column and entablature of one of the classic orders should be put together.

An octagonal post is first made by mitring and gluing the necessary number of planks together in such a manner that the centre of the post is hollow. If the finish wood is very expensive the planks are made thin and glued to a backing of pine or ash, which is not quite as well seasoned as the show wood, so that the shrinkage of the

\* This cut is taken by permission from an article by A. C. Nye, on "Interior Woodwork," published in the *American Architect* of October 22, 1892.

backing tends to close the joints in the show wood more tightly. The angles of the backing, or of the solid planks if no backing is used, should be splined together, as shown in section *B*. After the shell is glued up it is turned and fluted as if a solid timber.

In fluting the shaft, the flutes should be arranged so that the glue joint will come a little to one side of the centre of the flutes and not on the arris. "Practice has shown that when the joint is on the arris the thin edges necessarily resulting are likely to warp and the joint open. With the joint as shown there is no feather edge and a firm butt-joint can be made with little possibility of its opening."

The base is made of octagonal rings glued one on top of the other until the correct size is obtained, when it is turned into shape. The capital is so deeply carved in the example shown that thick pieces of wood are required at the outset, but the hollow space in the centre is retained. The shaft of the column should be rebated into cap and base.

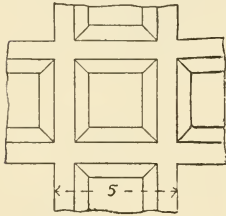

Fig. 284.

In the construction of the entablature a joint is made wherever possible, to diminish the liability to shrink. The frieze, being wide, is veneered, and the *congé* at *A* is made of a separate piece, which effects a considerable saving in material. The dentils are cut from one long strip of wood, and together with the blocks between them form a continuous length, which is fastened in place like any other moulding. The *cyma* at the top of the cornice is cut from a thick piece of wood, moulded on the flat and stiffened at intervals of about every 2 feet by blocks glued to the back.

## STAIRS.

183. While it is not necessary for an architect to be able to lay out the actual construction of a flight of stairs, or to tell just how the hand rail is to be worked, nevertheless he should be familiar with the general methods of constructing stairs, so that he can tell when they are properly built, and be able to plan the stairs in the buildings which he designs so that they may not only be ornamental, but also safe and comfortable. He should also be familiar with the various terms used in describing stairs, so that he can talk intelligently with the stair-builder and prepare a proper specification. The terms in general use amongst stair-builders are as follows: The term *staircase* is applied

to the whole set of stairs, including the landings, etc., leading from one story to another, or if several stories are connected by flights of stairs one above another, the whole series of stairs is included in the

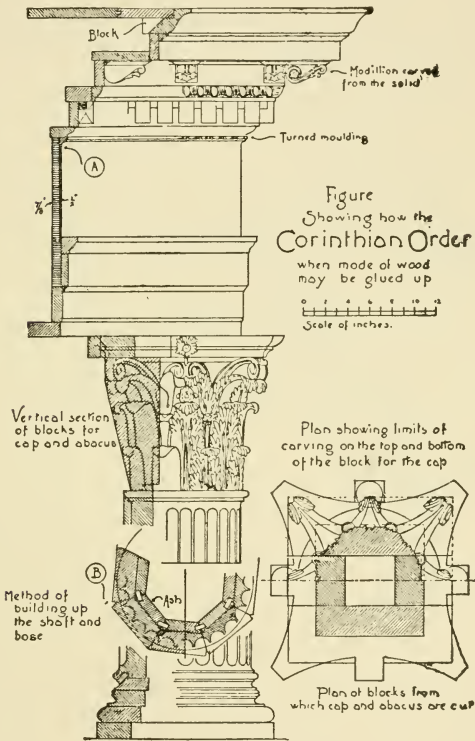

Fig. 285.

term. A *flight* of stairs is the portion of a staircase from the floor to a landing, or from one landing to another, or, if there is no landing, from one floor to the next. The *rise* of a stair is the height from the top of one step to the top of the next. The *run* is the horizon-

tal distance from the face of one riser to the face of the next.\* The *risers* are the upright boards, *R*, Fig. 286. The *treads* are the horizontal boards *T* which form the steps. The *nosings* include the projection of the treads beyond the riser and the small moulding placed in the angle. The *carriages* are the rough timbers which support the treads and risers. They are also sometimes called "strings" or "stringers." The *wall string* or *base* is the finished board placed against the wall corresponding with the base around the room. The *outside string* is the finished board on the outside edge of the stairs.

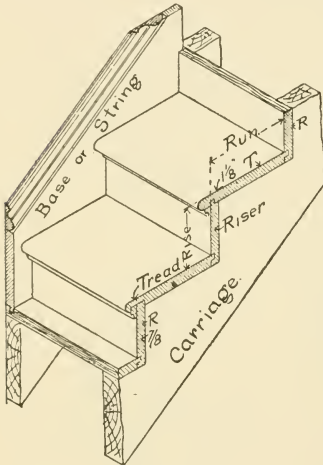

Fig. 286.

The *rise* of the stair should never be greater than 8 inches, and that only in inferior stairs. For grand staircases the rise is often made only  $5\frac{1}{2}$  or 6 inches, but to the average American this height is nearly if not quite as tiresome as an 8-inch rise. For ordinary use a rise of from 7 to  $7\frac{1}{2}$  inches makes a very comfortable stair. In schools and other buildings where the stairs are to be used largely by children the rise should be about 6 inches. The width of the run should be determined by the height of the rise; the less the rise the

The *newel* is the main post where the stairs begin; it is generally larger and more highly ornamented than the other posts. *Angle posts* are the posts used at the angles of a staircase or well. *Winders* are the steps which come in the angle of a flight of stairs, as *W W*, Figs. 290 and 292.

**Laying Out.**—In planning the stairs the architect must be governed to a great extent by the conditions imposed by the plan and arrangement of the building.

The first point to be considered will be the number of risers to be used, and then the width of the treads and the general arrangement of the stairs.

\* The terms "rise" and "run" are often used to designate the total rise or run of the stairs and not of the individual step, but, as they are much more useful terms when used as here defined, they will hereinafter be used with these meanings.

greater should be the run, and *vice versa*. A safe rule for this proportion is to make the sum of the rise and run equal to 17 or  $17\frac{1}{2}$  inches.\* Thus a 7-inch rise should have a 10 or  $10\frac{1}{2}$ -inch run and a  $7\frac{1}{2}$ -inch rise a  $9\frac{1}{2}$  or 10-inch run. The actual width of the tread will of course exceed the run by the projection of the nosing, which should be about  $1\frac{1}{2}$  inches.

The above rule applies only to steps with nosings. When there is no nosing, as is commonly the case with stone steps, the tread should be wider, seldom less than 12 inches.

The number of risers that will be required is determined by dividing the distance between the floor levels by the rise. It is seldom that the quotient will be without a fraction, and, as the risers should all be of the same height, it will be necessary to vary the assumed rise to conform to the number of risers adopted. Thus: supposing the distance between the top of the first and second floors of a building is 10 feet 9 inches and we wish to use a rise of about  $7\frac{1}{2}$  inches.

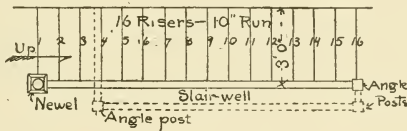

Fig. 287.

This rise is contained in 10 feet 9 inches (129 inches)  $17\frac{1}{2}$  times, so that we must use either 17 or 18 risers. The former would give a rise of  $7\frac{1}{4}$  inches and the latter a rise of  $7\frac{1}{8}$  inches. The run of the stair should be made either 10 or  $10\frac{1}{2}$  inches.

In figuring the stairs on the plan the number of risers only should be given, leaving the stair-builder to work out the rise from the actual height taken from the building, as this is apt to vary slightly from the height figured on the plans.

Besides the number of risers, the run and the width of the stairs from the wall to the centre of the rail should also be figured. For inferior stairs the width may be as little as 2 feet 9 inches, but never less than this. For the principal stairs in moderate-priced dwellings a width of 3 feet does very well, but 3 feet 6 inches is much better.

Having decided upon the number of risers and the run, the next

\* Another very good rule is that the product of the rise and run shall not be less than 70 nor more than 75. Still another rule, given the author by an experienced stair-builder, is that the sum of two risers and a tread shall be not less than 24 nor more than 25 inches.

step will be to arrange the stairs so that the requisite number of steps may be provided in the space available for them. This is often a difficult problem and one requiring considerable experience in planning for its satisfactory solution.

The simplest and cheapest method of building the stairs is to have a straight run, as shown in plan, Fig. 287, the dotted line showing the rail around the landing on the floor above. This frequently re-

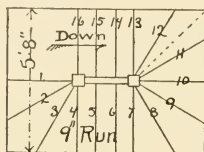

Fig. 288.

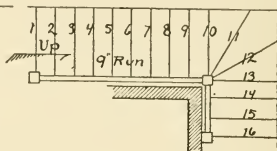

Fig. 289.

quires a longer space than is available, so that it is often necessary, especially in dwellings, to turn the stairs either at right angles or back on themselves to get the requisite number of steps into the space at hand.

For back stairways where the space is very limited the arrangement shown in Fig. 288 is generally adopted, as it occupies the minimum amount of space. If the rise does not exceed  $7\frac{1}{2}$  inches this makes a comfortable stairway, but when the rise is 8 inches it becomes

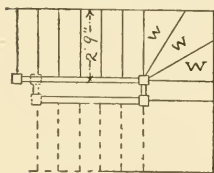

Fig. 290.

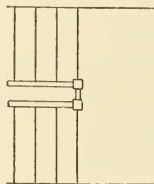

Fig. 291.

almost dangerous. Such stairs are very unhandy for carrying up furniture. Builders sometimes put four winders in the angles, as indicated by the dotted line; such an arrangement, however, is really dangerous, and the architect should never use more than three winders (two risers) in a space less than 3 feet 6 inches square. Fig. 289 shows a very common arrangement both for front and back stairs. When there is sufficient space the winders should be omitted and the straight flights lengthened to correspond.

In cottages, where the front stairs are built in this way, a closet or room often occupies the space usually devoted to the stair-well. With

such a plan the partition should be set back so that there will be a space of at least 2 inches between the outside of the rail and the partition, as shown in the figure. If the partition comes directly over the rail it is impossible to make a good finish of the latter, and there is also danger of one's hitting his head when ascending the stairs.

Fig. 290 shows an improvement over the stair shown in Fig. 288, although it of course occupies more space. The arrangement shown

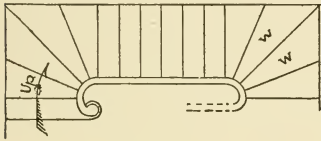

Fig. 290.

in Fig. 290 is sometimes termed an "open newel" staircase, while the stairs in Fig. 288 are termed "dog-legged."

Fig. 291 shows a full platform, which makes the easiest stair that can be designed, and if the platform is made wide

and fitted with a seat it makes a very ornamental feature. A staircase having a full platform is also much simpler of construction (*i. e.*, if the landing can be supported by partitions) than one with winders, or even with two platforms, and is also much firmer.

The various arrangements of stairs that may be made for ornamental effect in dwellings is almost unlimited, but in most cases they

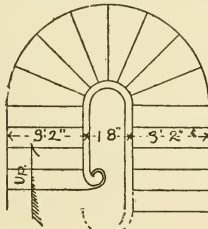

Fig. 293.

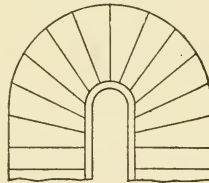

Fig. 294.

will be found to be made up of one or more of the arrangements here shown.

Previous to 1850 it was the fashion in this country to build circular or geometrical stairs, such as are shown in Figs. 292 and 293, for the principal staircase in the better class of houses. The latter plan is now seldom used, as it is a costly stair to build and not as easy or effective as the platform stair, shown in Fig. 291.

When winders must be used the objection to them may be largely overcome by using round corners, as shown in Fig. 292. This makes

the stairs much easier and also much more convenient for carrying up furniture. When it is necessary to use winders in public buildings they should wind around a circle of sufficient radius that the width of the treads at the narrow end shall be at least 4 inches, exclusive of the nosing.

*Balanced or Dancing Steps.*—Although winders are generally drawn as shown in Figs. 288–290, the stair-builder often builds them as shown in Fig. 295, the winders not radiating to the centre, but converging to different points, as also two or three steps on each side of the winders. This makes a much easier stair than the regular winders. The English term for steps arranged in this way is “balanced” or “dance” steps; there does not appear to be any term for this arrangement in common use among American stair-builders.

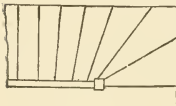

Fig. 295.

In geometrical stairs, such as those shown in Fig. 293, owing to the winding steps having the same rise as the others, but a much narrower tread at the inner end, the inclination of the line of nosings of the winders is much steeper than that of the other steps, which gives a sudden and ungraceful change to the inclination of the hand-rail. To avoid this and also to give some additional width at the narrow end of the tread the steps are “balanced,” as shown in Fig. 294, each riser converging to a different point.

**185. Head Room.**—The most common fault with stairs, particularly in dwellings, is the lack of sufficient head room. One should

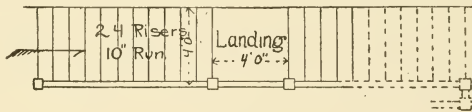

Fig. 296.

never calculate on less than  $6\frac{1}{2}$  feet from the under side of the floor opening to the top of the tread below, and 7 or 8 feet of head room is much better.

With the ordinary thickness of floors in dwellings the well room should extend over at least 12 risers when the rise is over  $7\frac{1}{2}$  inches, and 13 or 14 risers when it is less.

Where one flight is built directly above another the vertical distance between the two should not be less than 7 feet 6 inches in the clear, measured over the face of the riser.

The architect or draughtsman cannot be too careful in this par-



ticular, as expensive and otherwise well-arranged stairways are often greatly marred by too close head room.

When planning the stairs for buildings of a public nature the first consideration should be the comfort and safety of the people using them.

Landings should be provided every ten or twelve steps, which should be as long as the width of the stair, and winders should be entirely avoided, unless placed on a circle, as previously described. The rise of the stairs in public buildings should not exceed 7 inches. All sudden alterations in the length of flights should be avoided and *no flight of less than three risers* should be permitted. The use of single or isolated steps in public buildings is dangerous and is prohibited in most of our large cities.

*Width of Public Stairs.*—The width of the stairs should be proportioned to the greatest number of people that may possibly have occasion to use them at one time. The law regulating the construction of build-

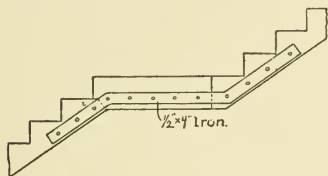

Fig. 297.

ings in the city of New York provides that "Stairways serving for the exit of fifty people must, if straight, be at least 4 feet wide between railings, or between walls, and if curved or winding, 5 feet wide, and for every additional fifty people to be accommodated 6 inches must be added to their width."

"In no case shall the risers of any stairs exceed  $7\frac{1}{2}$  inches in height, nor shall the treads, exclusive of nosings, be less than  $10\frac{1}{2}$  inches wide in straight stairs. In circular or winding stairs the width of the tread at the narrowest end shall not be less than 7 inches."

In general the stair shown in Fig. 291 is the best for public buildings, and next to this is the straight stair with a platform near the centre, as in Fig. 296.

Stairs should be well lighted, particularly at their approaches, and in hotels, factories and other buildings of a public nature a skylight should be placed above the stair-well, both for lighting and for ventilation.

**186. Construction.**—The foregoing observations apply in the main to all stairs, whether of wood, metal, stone or brick.

The construction of the stairs, however, varies with the kind of

material used, and as this book treats only of wooden construction, only the methods of constructing wooden stairs will be described.

In the construction of wooden stairs two distinct methods are employed, the advocates of each claiming that theirs is the best. Each method naturally possesses some advantage over the other, and while in most cases either method will give satisfactory results, there are often particular conditions under which one or the other is better adapted.

As there are no well-recognized terms for designating the different methods, it is necessary to describe in the specifications the particular manner in which the stairs are to be built.

By the first method, which might be designated as the *Boston method*, as it is the principal method used in that vicinity, the

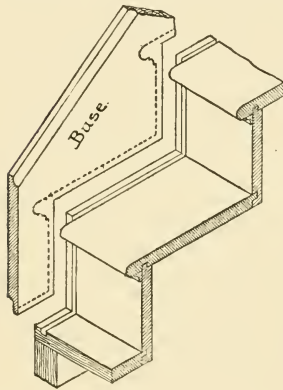

Fig. 298.

carriages and other supports for the finished stairs are put up by the stair-builder before the building is lathed, temporary treads being nailed to the carriages for the convenience of the workmen. The carriages are accurately cut from pine or spruce planks to fit the treads and risers and made to line perfectly true, level and square. As they carry the weight of the stairs and the loads which come upon them they should be securely fastened in place and the timber on which the bottom of the carriages rest should be of sufficient strength to carry the entire weight of the

flight above it. For first class work the carriages should be spaced 12 inches on centres, and in long flights a false riser should be spiked to the rise of the carriages every four or five steps, as shown in Fig. 308, the step being cut back to allow for the thickness of the board.

When a straight flight of stairs, with a platform, like that shown in Fig. 296, is to be built it is desirable to extend the platform posts to the floor timbers below, but if this cannot conveniently be done, and there is no partition under the outer carriage, the carriages may be supported or strengthened at the platform by pieces of flat iron, screwed or bolted to each carriage, as shown in Fig. 297. Stairs for

public buildings, factories, etc., however, should invariably have the platform posts carried down to a solid support.

After the plastering is dry, and while the other interior finish is being put up, the stair-builder puts in place the finished portions of the stairs *one piece at a time*. The treads and risers are all "got out" at the shop, the under sides of the treads being grooved to receive

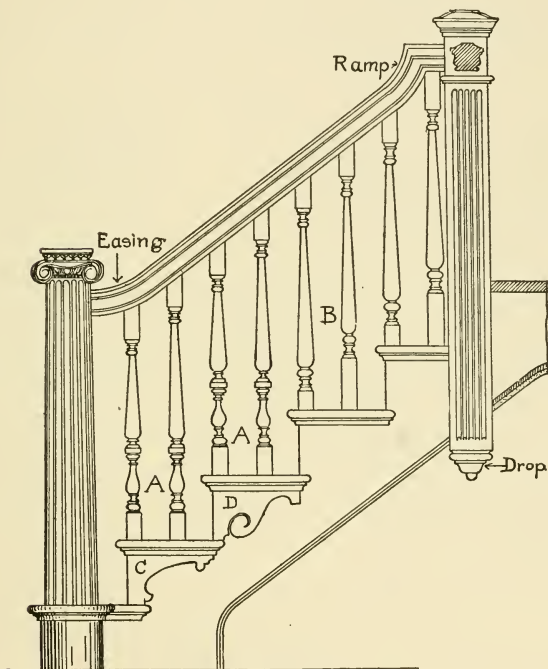

Fig. 299.—Open String.

a tongue worked on the upper edge of the riser and the bottom of the riser grooved to receive a tongue on the back edge of the tread, as shown in Fig. 298. The risers are first nailed to the carriages, commencing at the top, and then the treads are fitted into them and nailed. The wall string or base is roughly scribed to the profile of the stairs and the edge cut away at the back to form a tongue, which

is then driven into a groove cut in the ends of the treads and risers, as shown in the figure, the nosing being cut off so as to butt against the base. This permits of shrinkage in the base, without leaving an open joint at the intersection. Considerable care has to be exercised in cutting the groove for the base to get it at exactly the right distance from the wall line.

In this method no glue or blocking is used for holding the treads, risers or strings, but all parts are secured to the rough work by nails.

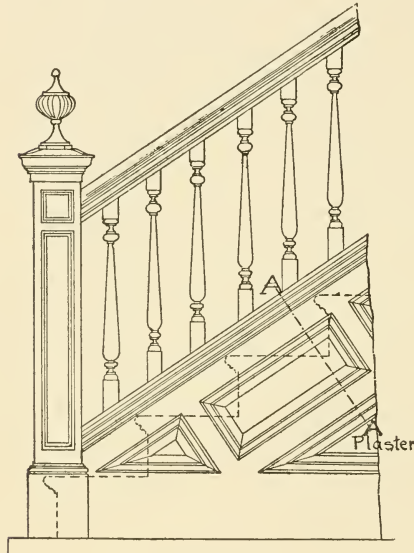
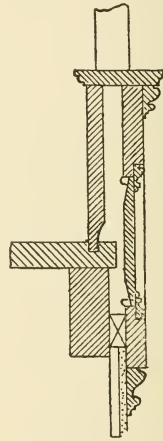

Fig. 300.—Closed or Curb.



Section on line  
A A, Fig. 300.

Fig. 301.

The outer face of the stair may be finished either as shown in Fig. 299 or as in Fig. 300. The former is called an *open string* and the latter a *closed or curb string*; the open string in this method of construction being the cheaper.

In "open string" stairs a plain board, cut to the profile of the stairs and mitred against the ends of the risers, is first nailed to the carriage or blocked out from it so as to cover the plaster, and the nosing is continued across the end of the tread by means of a solid moulding worked to the shape of the nosing and mitring with it, as

shown by the detail drawing, Fig. 303, the other end of the moulding being returned on itself. Before this moulding is fastened in place the balusters are dovetailed into the ends of the treads as shown at *F*.

If the stairs are to be finished with a "closed string" the string in this method of construction is made hollow, as shown by the section

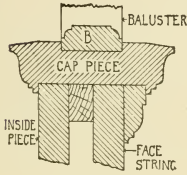

Fig. 302.

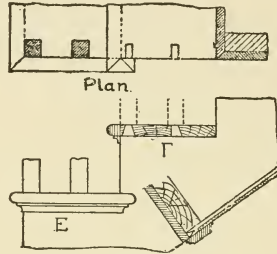

Fig. 303.

Fig. 301, the inner part being tongued into the treads and risers in the same way as the wall string. The outer string is then put up, being generally nailed to furring blocks, and the top member being next fastened in place to complete the string; the balusters being either mortised into it or simply cut on a bevel and nailed. As the string must

be quite wide it is generally paneled to prevent excessive shrinking. Fig. 302 shows another method of capping a curb string, which the author prefers to that shown in Fig. 301. The piece *B* is cut between the balusters and holds them in place.

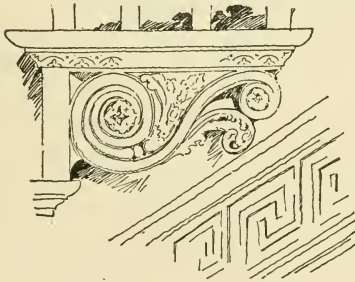

Fig. 304.

Open string stairs are often ornamented by planting thin brackets of wood on the face of the string before the nosing is put on, as in *C* and *D*, Fig. 299. They should be mitred with the end of the riser. In very ornamental work these brackets are usually carved, as shown in Fig. 304.

Stairs are sometimes finished as in Fig. 305, the back and under side of the steps being paneled to appear like solid steps.

The newel and angle posts, which are generally built up out of thin stuff, are put up before the string and the latter is housed into them.

Stair-builders will sometimes try to convince the architect that to secure a strong stair it is necessary to build in the angle posts when the carriages are put up, but if the stair-builder thoroughly understands his work the framework can be as solidly constructed without the posts, which may then be put up with the other finish work and thus escape being sub-

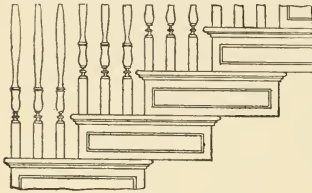

Fig. 305.

jected to the dampness invariably produced by the wet plastering. In inferior pine stairs the posts may be built in with the carriages and boxed to prevent being injured.

187. In the second method of construction, which may be called the *English method*\*, the finished portion of the stairs is all put together at the shop and carried bodily to the building and set in place on the carriages, which are often made as

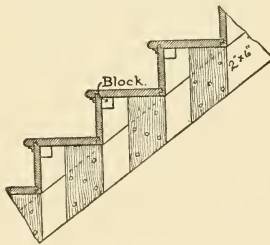

Fig. 306.

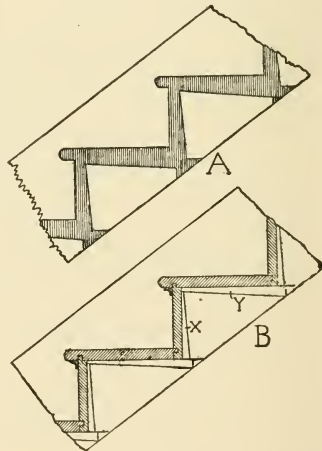

Fig. 307.

in Fig. 306. When built in this way the treads and risers are generally tongued together as before described, except that sometimes

\* The author is informed that this method is used almost exclusively in California, and to a considerable extent throughout the West.

the moulding under the nosing is also ploughed into the tread, and all glued together.

The connection of the treads and risers with the base (called in this construction the "wall string"), however, is made in an entirely different manner; the profile of the stair, including the nosing, is carefully traced on the string, which is then cut out as at *A*, Fig. 307, so that the ends of the treads and risers may be "housed" into it at least  $\frac{1}{2}$  inch, and then wedged and glued, as shown at *B*.

The treads and risers should also be blocked and glued together, as shown in Fig. 306.

The outer string is then put on and glued, and if a curb or close string the treads and risers are housed into it, as with the wall string, a single string  $1\frac{3}{4}$  inches thick often being used in that case.

When this method of construction is used the base or wall string should be at least  $1\frac{1}{2}$  inches thick, and it is better to have a curb string on the outside, the inside face being worked in the same way as the wall string.

For the inferior stairs in dwellings this makes the cheapest construction, and if well housed, blocked and glued, they will have sufficient

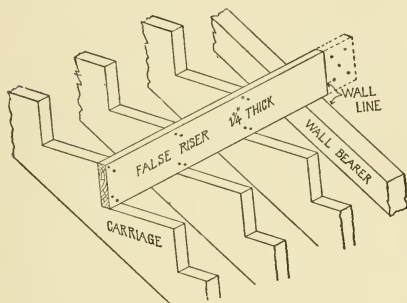

Fig. 308.

strength without carriages, when not over 3 feet wide, and the string on each side is solidly nailed to a partition. It is customary in such stairs, however, to put up 2x4 joist under the stairs to help support them and also to receive the lathing underneath.

When the stairs are put together in the shop the only way in which they can be accurately fitted to the carriages is by wedges driven from below, and this obviously can not be done after the soffit or under side of the stairs is plastered, so that the plastering, if there is any, must be done after the stairs are finished.

This is a very serious objection to the English method of construction, as no plastering should ever be done in a building after the finished work is in place, especially if the wood is to be varnished. If the stairs are put up without wedging they are pretty sure to squeak.

The author, therefore, in his own practice always specifies the Boston method of construction for all but inferior pine staircases, unless the stairs are to be paneled underneath, in which case a better job can usually be obtained by the English method of construction. Where plastering is necessary after the woodwork is completed, some kind of plaster board should be used for the ground, and then only a thin white coat will be required to finish it.

The treads in stairs for public buildings, if of wood, should be of oak (Georgia pine or Oregon pine will answer very well) and never less than  $1\frac{1}{2}$  inches thick, and  $1\frac{3}{4}$ -inch treads are often used.

When more than  $1\frac{1}{2}$  inches thick, however, it is a good idea to groove them on the bottom, as at *A*, Fig. 309, so that they will not warp.

There is still another method of stair building much used in Pennsylvania, which is a combination of the two methods above described. In this method the carriages or horses are cut to fit the steps, as shown in Fig. 308, and put up to line perfectly. To the wall, a 3x4 or 3x6 joist, called the "wall bearer," is nailed or spiked, so that the top will be about  $\frac{3}{4}$  inch below the back edge of the risers.

In long flights a false riser is nailed to every fifth or sixth riser of the carriages (the treads being cut short for the purpose) and fastened securely to the wall, the inner end being thrown a little higher than level. This braces and

stiffens the work very much. After the plastering is dry the wall string is set and nailed to the wall, having been previously housed out for the steps as in the English method.

The risers and treads are then driven into the wall string, commencing at the bottom, and nailed to the carriages

Wedges are also driven in and glued on top of the wall bearer to give additional support to the back edge of the steps, as shown in Fig. 309.

The inside of face string (if a curb string) is then tongued into a groove cut in the treads and risers, as in the Boston method. This method differs from the Boston method only in the wall bearer and string and in having the wedges on top of the wall bearer, and in this respect is probably superior to the first method described.

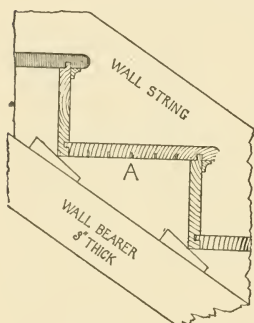

Fig. 309.



For the finest grades of work the material should all be painted on the back and filled and shellaced on the face before taking to the building, which should be thoroughly dried out beforehand.

**188. Posts and Railing.**—The stair posts, if made of hard wood, should be built up out of thin pieces. Turned posts of hard wood are not usually desirable, as if turned from a solid stick they are very apt to check, and if glued up to open at the glue joints. A newel, such as shown in Fig. 299, should be built up in the same way as the Corinthian column shown in Fig. 285. Angle posts should be extended below the outside string and should have an ornamental drop at the bottom.

In principal staircases the architect should provide for a half post where the rail terminates against a wall, as otherwise the stair-builder will fasten the rail to a wooden or iron plate screwed to the wall, which does not make as neat a finish as the half post.

*Hand-Railing.*—The section of the hand-rail is more a matter of

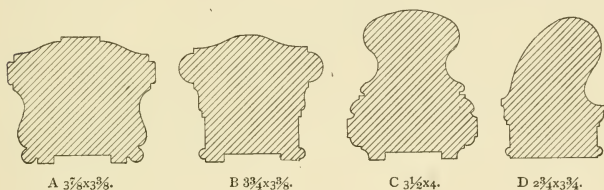

Fig. 310.

taste than of construction and may be designed to conform to the interior finish. As a rule, however, the section of the rail should contain at least 9 square inches,  $3\frac{1}{2} \times 3\frac{1}{2}$  inches being a very good size. Several good sections are shown in Fig. 310, the scale being one-fourth full size. The section at D is preferred by many for public buildings, but for residences one of the other sections seems more pleasing and appropriate.

A safe rule for the height of the rail is to make it about 2 feet 6 inches above the tread, on a line with the face of the riser. For grand staircases the height is sometimes reduced to 2 feet 4 inches, but for steep stairs it should never be less than 2 feet 6 inches. The rail should also be raised over winders, especially those of a steep pitch.

On the landings the height of rail should be equal to the height of the stair rail measured at the centre of the tread, the usual height in residences being 2 feet 8 inches to 2 feet 10 inches.

In ordinary stairs the rail is generally straight, joining the posts at

an oblique angle, as in Fig. 300. At the angle posts the rails, if made straight, will strike the post at different heights on the opposite sides of the post, and to overcome this the rail is often *ramped*, as shown

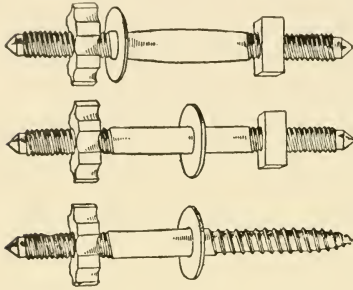

Fig. 311.

builder cannot be expected to put them in unless they are mentioned in the specifications or shown on the stair drawings.

*Wall Rails.*—Stairs which may be used by large numbers of people should have a rail on the wall side of the stair when 4 feet wide, and also all stairs built between partitions should have at least one wall rail. These rails are generally made with a round section of about  $2\frac{1}{4}$  inches in diameter, and should be fixed to the wall on iron or bronze brackets made for the purpose. The ends of the rails are sometimes left straight, but it is better to return them against the wall.

Stairways from theatres and large halls, when over 12 feet wide, should have a rail in the centre, strongly supported.

All end joints in rails and connections between rails and posts should be made by means of joint bolts or hand-rail screws, of which three patterns are shown in Fig. 311.

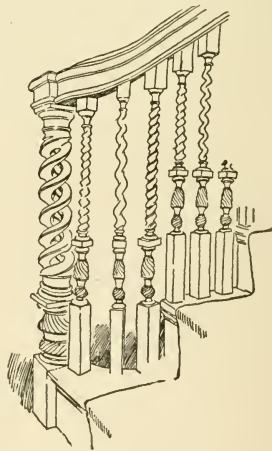

Fig. 312.

in Fig. 299, the height of the ramp being made such that the rails on each side of the post will come at the same height.

The lower end of the rail is also often finished with an *easing* (in English books termed *knee* or *kneeling*), as shown in the same figure.

Ramps and easings add much to the appearance of a stair, but they also add to the cost, and the stair-

*Balusters* are intended to support the hand rail and to prevent any one from falling over the ends of the steps; they may also be made an ornamental feature. They should be made of some kind of hard wood and may be of almost any size, although  $1\frac{1}{2}$  to  $1\frac{3}{4}$ -inch balusters are most largely used. They are generally square at the ends and turned or twisted between. Twisted balusters make a very handsome railing for residences, and were much used in Colonial

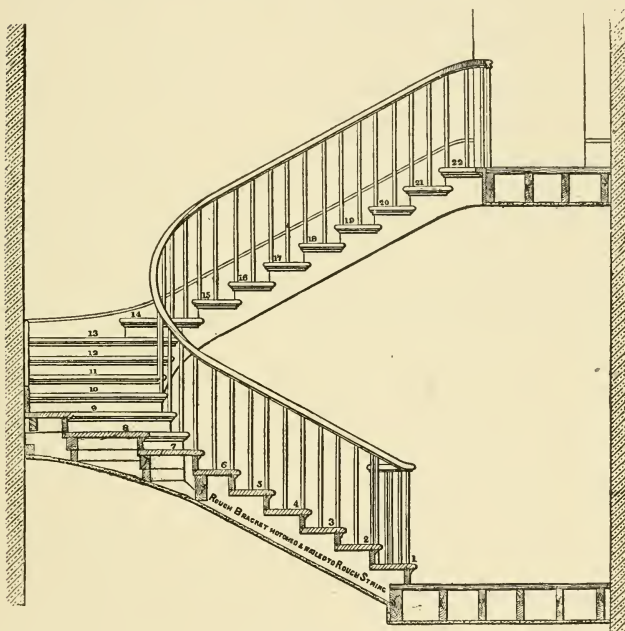

Fig. 313.

mansions. They can now be turned by machinery at a very moderate cost. Generally two or three patterns are used, as shown in Fig. 312. In open string stairs the balusters should be doweled into the treads at the bottom and nailed or screwed to the under side of the rail. If the top of the baluster is round it should be doweled into the rail.

Usually two balusters are placed on each step, one flush with the face of the riser and the other half way between the risers. When the run exceeds 10 inches three balusters to the tread give a much nicer appearance, and in residences three 1½-inch balusters look much better than two larger ones.

There are two methods of arranging the turned portion of the balusters in open string stairs. One is to keep the square base the same height on each step, varying the height of the turning as shown at *A*, Fig. 299, and also in Fig. 312, and the other is to make the turned part of the baluster of the same length in each, varying the height of the square part to conform to the rake of the stairs, as shown at *B*. With a close string every baluster is alike, although with this style of stair open panel work or heavy balusters and arches are often used instead of the ordinary balusters.

*Geometrical stairs* have no newel or angle posts. The flights are arranged around a well hole in the centre, as in the plan Fig. 293, and each step is supported by having one end housed into the wall string and the other end resting upon the outer string, but partly drawing support from the step below it. The face string is generally strengthened by a flat iron bar screwed to its under side. The hand-rail is uninterrupted in its course from top to bottom.

Fig. 313 shows a sectional elevation of a geometrical stair with winders.

#### FIXTURES AND FITTINGS.

**189.** Besides the standing finish there is usually in dwellings considerable work in the way of fixtures and fittings for pantries, closets, etc., to be provided, and also more or less work to be done in connection with the plumbing.

With modern plumbing, what little woodwork is required in connection with the fixtures is usually provided by the plumber, but it is well to specify that the carpenter shall put up all brackets and hang the water closet seats, etc., as a carpenter will usually do the work better than a plumber. The specifications should also provide for putting up finished cleats with moulded edges for all exposed plumbing pipes, and for fixing cleats under the marble slabs where they are set against wooden wainscoting.

Many architects also provide for a short hook strip in the bathroom, with about four solid bronze clothes hooks.

If the plumbing pipes are run in pockets in the wall they should be covered by a wide board or by panel work let flush into rebated strips and secured with iron or bronze buttons.

*Kitchen Sink.*—The specifications should also state how the kitchen sink is to be fitted up.

When slate or soapstone sinks are used there is usually no wood-work about them.

Ordinary iron sinks require a wooden frame to support them and a wooden cap to cover the edges. At one or both ends of the sink a drip board at least 18 inches long should be provided. The cap and drip board should be at least  $1\frac{1}{8}$  inches thick, and the drip board should be slightly inclined and grooved on top. If the space under the sink is left open an apron 4 inches wide is required under the cap to cover the rough frame.

*Closets.*—All bedroom closets should be fitted with strips and clothes hooks and at least one shelf. Large closets are often provided with a case of drawers with three or four wide shelves above them.

Every large residence should be provided with a *linen closet* fitted with a case of deep drawers and as many shelves, 16 inches wide and about as many inches apart, as there may be room for. It is also desirable to enclose the shelves with paneled doors as a protection from dust.

*Cedar Closet.*—The most complete residences are also provided with a "cedar closet," for the reception of articles that may be injured by moths. To be effective the entire inside of the closet, floor, walls and ceiling, should be lined with cedar, using  $\frac{1}{2}$  or  $\frac{5}{8}$ -inch ceiling, and the inside of the door should also be ceiled or veneered with the same wood. The closet is usually fitted with one or more cases of wide and deep drawers, with wide shelves above, enclosed by doors. The shelves and doors should be of cedar, but where economy is necessary the drawers may be of pine lined with thin cedar. Drawers lined in this way are sometimes placed in an ordinary closet, but as it is the odor as well as the bitter taste of the cedar that keeps away the moths, it is desirable that the entire closet be protected with it.

The cedar which should be used for this purpose is the Florida or Alabama red cedar. (See Section 30.)

Besides the above there are often one or more special closets whose fittings should be fully described. Detail drawings are not usually necessary for the above fittings, as they may be described with sufficient accuracy in the specifications.

**190. China Closet or Butler's Pantry.**—The arrangement and extent of the fittings for this closet or room will, of course, depend greatly upon the plan and the character of the house.

A reasonably complete china closet should have a counter shelf about 28 inches wide and 2 feet 8 inches from the floor across two

sides of the room. Below this shelf should be drawers to receive the table linen—one long one for table cloths and shorter ones for napkins, etc. One drawer should also be divided for knives, forks and spoons. If there is room one or two cupboards should also be provided beneath the counter shelf.

Above the wide shelf there should be a number of shelves 14 inches wide for china and glassware. These shelves should be enclosed with glass doors—sliding doors are generally considered the most convenient.

A well-equipped butler's pantry should also be provided, with a small sink for washing the china, glass and silver.

*The kitchen pantry* should be fitted with a counter shelf as long as the space will permit, with at least one case of drawers about 3 feet long and cupboards under and open shelves above. A strip for pot hooks is also often provided. Provision should also be made in the pantry for flour. Where flour is sold by the barrel, as is the case in the Eastern States, it is customary to arrange a cupboard under the counter shelf with a door large enough to admit the barrel and a lifting cover in the counter shelf for taking out the flour from the top.\*

In many of the extreme Western States flour and meal are sold only in cotton bags containing either 25 or 50 pounds, and in those States it is customary to put *flour bins* under the counter shelf—one for flour and one for meal. These bins are tight boxes about 18 inches wide, 16 inches deep and 2 feet 3 inches high, which are pivoted at the bottom so that the top may be brought forward for taking out the meal or flour and then pushed back under the shelf. Such bins are very convenient, but mice sometimes find their way into them, and for this reason many housekeepers prefer to keep their flour in tin cans made especially for the purpose. If such cans are to be used, provision should be made for them in the pantry.

*Kitchen Dresser.*—In many small houses there is room only for one closet, which is made to serve for both china closet and pantry. With such a plan it is desirable to have a dresser in the kitchen in which the kitchen utensils may be kept, and many housekeepers prefer a good dresser to a kitchen pantry. The dresser is usually made about 8 feet high and from 5 to 10 feet long, according to the size of the kitchen. It should have a counter shelf at least 20 inches wide, dividing it into upper and lower sections. The section below the counter shelf should have a place for flour, two or three drawers and

\* Pivoted clamps for flour barrels (Perfection barrel swings) have recently been placed on the market, by means of which the barrel can readily be swung out of the closet instead of reaching through a door in the shelf.

the remainder finished off for cupboards for pots and pans, with paneled doors. Above the counter shelf there should be about four shelves 12 or 14 inches wide. These shelves should always be enclosed with glazed doors, either arranged to slide by each other on brass tracks, or hung with hinges at the sides. The width of swinging doors should not exceed 18 inches, and a width of 15 inches is about the most convenient, the doors being arranged in pairs. Sliding doors may be from 18 inches to 2 feet wide. When the counter shelf is narrow it is a good idea to arrange for a drawer shelf immediately under the counter shelf, which may be drawn out when needed. As a dresser is really a piece of furniture, although generally fixed in place, it should be neatly made with paneled doors and ends, and finished on top with a simple cornice. The wood should be the same as the finish of the room.

To insure the best arrangement of doors, cupboards, drawers, etc.,

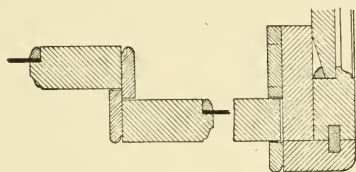

Fig. 314.—Detail of Sliding Cupboard Doors and Frame.

for the pantry, china closet or dresser, the architect should make scale drawings showing the fittings at the different sides of the rooms, with full-size sections for any special mouldings or details.

*Clothes Chute.*—In many residences a clothes chute

is provided, running from some place in the second story (from the bathroom when practicable) to the laundry. The chute is merely a vertical shaft or well about 16 inches by 2 feet inside, lined with matched ceiling and provided with doors in each story.

*Dumb Waiter.*—If a dumb waiter is required a shaft for it to operate in must be provided, with doors opening at the proper level in the different stories. The shaft should be ceiled inside and a pocket provided for the weights if one is necessary, with pocket pieces (to give access to the weights) secured with screws.

A description of dumb waiters, with the lifting apparatus, is given in the Appendix.

**191. Details of Cupboards, Drawers, Bookcases, etc.**—To properly detail a case of drawers, cupboard doors, etc., the draughtsman must be familiar with the different methods of constructing them. Cupboard doors are made in essentially the same way as other doors, except that they are usually thinner and have

narrower rails and stiles, with the panel mould worked on the solid. For a door 2 feet by  $4\frac{1}{2}$  feet or less, a thickness of  $1\frac{1}{8}$  inches is ample, while the stiles and rails should be about  $2\frac{1}{2}$  or 3 inches wide, the lower rail being usually made 1 inch wider than the others. The panels should not be over 12 inches wide, and 8 or 10 inches are better widths. A door 2 feet wide and over 3 feet high should have four panels.

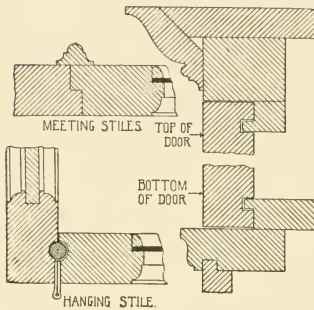

Fig. 315.

When doors are used in pairs the meeting rails are usually rebated and beaded.

If the doors are arranged to slide, a slight space must be left between the doors—about  $\frac{3}{16}$  inch—and a stop bead nailed to the edges, as shown in Fig. 314, to keep out dust. The outer edges of the door should also fit into a groove in the frame for the same reason.

When it is desired to make swinging doors dust proof, the edges of the doors should be fitted something as shown in Fig. 315, with the meeting stiles rebated and the joint covered with an astragal.

The ordinary method of hanging the doors, cases, cabinets, etc., is

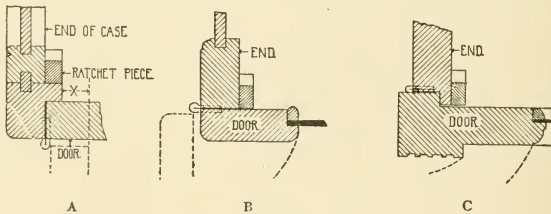

Fig. 316—Methods of Hanging Doors of Cases.

that shown at *A*, Fig. 316. On bookcases, or wherever it is desirable to utilize the full width of the opening, there is a serious defect in this method, in that when the door is open at right angles it reduces the opening by the width *X*, or nearly the entire thickness of the door. To obviate this the door may be hung as shown at *B* or *C*. The last detail is intended to represent the jamb of a bookcase



finished with pilasters at the angles, which are made a part of the doors instead of being fastened to the case, thus gaining the full length of the shelves when the door is open.

Very often, as on bookcases and fine cabinets, it is desirable that the hinge shall not be seen, and then the pivot or pin hinge is used.

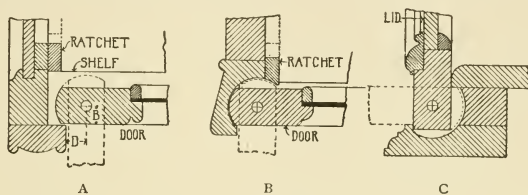

Fig. 317.

Bookcase doors are frequently pivoted, as shown at *A*, Fig. 317. In locating the pivot the distance *D* should be about  $\frac{1}{16}$  inch more than the distance *B*. For a bookcase, however, this method of pivoting the doors is decidedly objectionable for several reasons. First, it narrows the opening by the full width of the door; the shelves must be made narrower than with swinging doors and dust easily enters at the edge of the door. A much better arrangement is that shown at *B*, which leaves the full width and depth of the case available.

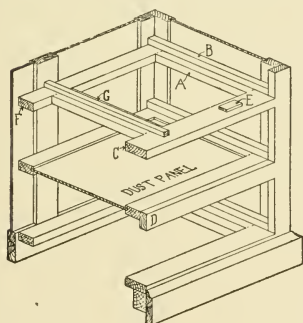

Fig. 318.

At *C* is shown what is probably the best method of hanging or pivoting the lid of a small desk or cabinet that opens down. By this arrangement the lid is made self-supporting when open, without the aid of elbow braces or chains, and the pivot hinge

can be made quite strong, while being at the same time concealed.

**192. Drawers.**—These occur in most of the fittings usually designed by the architect, and the better modes of construction should be familiar to every draughtsman.

The successful operation of a drawer depends both upon the construction of the drawer and of the case in which it works. The case

should be made so that there will be only sufficient contact with the drawers to support and guide them. Fig. 318 shows the usual construction of the case with the top omitted. The bottom edge of the drawer slides on the piece *A*, while the piece *B* guides it. The piece *C*, which separates the drawers, is usually but  $\frac{3}{4}$  or 1 inch thick. If a greater space is desired between the drawers a strip is glued to the edge as at *D*.

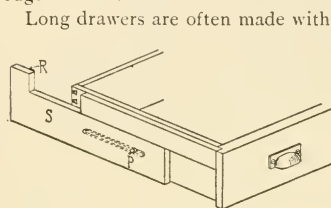

Fig. 319.

Long drawers are often made with a centre guide, as shown at *G*, blocks being glued to the bottom of the drawer to slide each side of the guide. Long and shallow drawers work much better with such a guide, and the guide also serves to support the bottom. In the best work a "dust panel" is placed in the frame between the

drawers so that when the drawer is removed from the pocket it is impossible to reach the contents of the drawer below; the panel also keeps out more or less dust.

When it is desirable that the drawer may be withdrawn its entire depth without falling, sliding pieces, *S*, may be arranged at each side of the drawer, in the manner shown by Fig. 319. As the drawer is

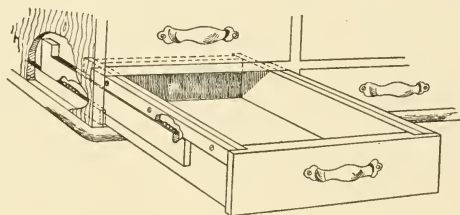

Fig. 320.

drawn out it slides first on the sliding piece *S*, and when half open a pin, *P*, engages in the sliding piece and draws it out. The piece *S* holds the drawer and keeps it from falling. The slide *S* is prevented from tipping by the shoulder *R*, which bears against the under side of the piece *A*, Fig. 318.

Fig. 320 shows the Kimball Ball-Bearing Drawer Slide, which is similar to the arrangement above described, but with the addition of

steel balls inserted in grooves, which decreases the friction. These slides are sold at a very moderate price, and are quite extensively used in libraries and public buildings; they are worthy of a more extended use in dwellings and for all drawers that are to be much used. The "Turner" anti-friction drawer slide works on the same principle but has wheels in place of balls. The author understands that the slide without the balls is not now protected by patent.

The construction of the drawer itself is quite simple, the variations being only as a rule in the front piece and in the joints.

The sides and back of the drawers are usually from  $\frac{7}{16}$  to  $\frac{5}{8}$  inch thick, and the bottom from  $\frac{3}{8}$  to  $\frac{1}{2}$  inch thick. The drawers slide on the bottom edges of the side pieces and the bottom is grooved into the front and sides. The back is commonly tenoned or grooved into the sides and rests on the bottom. The bottom should always have the grain of the wood running across the drawer, and should extend a little beyond the back piece to allow for shrinkage. It should not be fastened except at the front.

Drawers may be either plain front, panel front or lip front, as

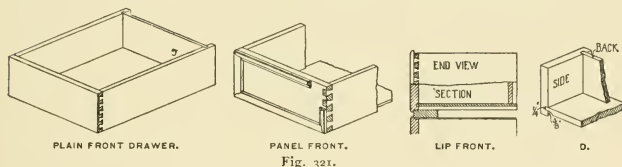

shown in Fig. 321. The panel front is usually formed by nailing or gluing a panel mould around the edges of a plain front, the drawer being pushed back until the moulding is flush with the front of the case. When the front and sides are connected by a full dovetail joint this makes a very strong and handsome drawer. The front of a "lip front" drawer is rebated around all four edges, so as to project about  $\frac{1}{4}$  inch over the face of the case to keep out dust. The lip front drawer should be used where the appearance is not of great consequence and where it is desirable to keep out dust as much as possible, such as drawers for linen, clothes, etc. Lip front and plain front drawers are usually lap dovetailed to the sides, as shown in the illustrations. Carpenters often simply rebate the ends of the front and nail the sides in the rebate, but this makes a bungling piece of work, and the nails are apt to split the sides.

In furniture work the back and sides of the drawers are usually dovetailed together, but in most mill work they are simply grooved

and nailed together, as at *D*. The groove in the side pieces for the bottom piece should be kept up  $\frac{3}{8}$  inch from the lower edge. If a greater thickness than  $\frac{1}{4}$  inch is necessary for the bottom piece, it may be cut away at the edges as shown.

Specifications for drawers should state the kind of front desired and how the parts are to be joined.

When a drawer is hung from a table top or shelf, the best arrangement for the slide is that shown in Fig. 322. When the slide is placed at the top of the drawer there is sure to be friction against the under side of the table top unless the drawer is loosely hung, which is also objectionable.

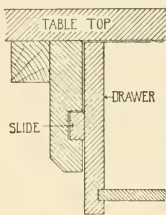

Fig. 322.

A drawer for a corner cabinet cannot of course be made to slide, but it may be pivoted to work as in Fig. 323.

*Mantels, Sideboards, etc.*—The details of mantels and sideboards depend almost entirely upon the design, and as this may vary indefinitely it is impossible to give any illustrations that would be of much value. In general the same principles of construction that have been given for cabinet work or finish apply to these fixtures.

**193. Dimensions for Furniture.**—For the convenience of draughtsmen when designing furniture or providing space for a special article, the following dimensions, furnished by Mr. Alvin C. Nye, are given :\*

*Chairs and Seats.*—The average figures taken from a variety of good chairs are : Height of the seat above the floor, 18 inches ; depth of the seat, 19 inches ; the top of the back above the floor, 38 inches. Usually the seat increases in depth as it decreases in height, while the back is higher and slopes more. Twenty inches inside is a comfortable depth for a seat of moderate size. Chair arms are about 9 inches above the seat. The slope of the back should not be more than one-fifth the depth of the seat. A lounge is 6 feet long and about 30 inches wide.

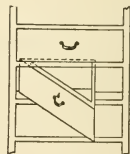

Fig. 323.

*Tables* vary in shape and size almost as much as chairs. Writing and dining tables are made 2 feet 5 inches high, and the species of sideboard called a carving table is made 3 feet high to the principal shelf, but tables for general use are 2 feet 6 inches high.

\*These dimensions were first published in the *American Architect* of November 10, 1894.

Dining tables are made to extend from 12 to 16 feet by means of slides within the frame. This frame should not be so deep as to interfere with the knees of any one sitting at the table ; that is, there must be about 2 feet clear space between it and the floor.

The smallest size practicable for the knee-holes of desks and library tables is 2 feet high by 1 foot 8 inches wide. The width to be increased as much as possible.

*Bedsteads* are classed as single, three-quarters and double. A single bed is 3 feet to 4 feet wide inside ; a three-quarter bed, 4 feet to 4 feet 6 inches ; a double bed, 5 feet. All bedsteads are 6 feet 6 inches to 6 feet 8 inches long inside. Footboards are from 2 feet 6 inches to 3 feet 6 inches, and headboards from 5 feet to 6 feet 6 inches high.

*Bureaus* vary in shape and size to such an extent that is impossible to say that any dimension is fixed.

Convenient sizes are : 3 feet 5 inches wide, body, 1 foot 6 inches deep, 2 feet 6 inches high ; or 4 feet wide, body, 1 foot 8 inches deep, 3 feet high.

Commodes are 1 foot 6 inches square on the top, and 2 feet 6 inches high.

Chiffoniers are 3 feet wide, 1 foot 8 inches deep, 4 feet 4 inches high.

Cheval glasses are made, if large, 6 feet 4 inches high, 3 feet 2 inches wide. If small, 5 feet high, 1 foot 8 inches wide. If medium, 5 feet 6 inches high, 2 feet wide.

Washstands of large sizes are 3 feet long, 1 foot 6 inches wide, and 2 feet 7 inches high. Small sizes are 2 feet 8 inches long.

Wardrobes may be 8 feet high, 2 feet deep, and 4 feet 6 inches wide. Or, 6 feet 9 inches high, 1 foot 5 inches deep, 3 feet wide.

Sideboards may be 5 feet to 6 feet long, and about 2 feet 2 inches deep.

Upright pianos vary from 4 feet 10 inches to 5 feet 6 inches in length ; from 4 feet to 4 feet 9 inches in height, and are about 2 feet 4 inches deep, over all.

Square pianos are about 6 feet 8 inches long by 3 feet 4 inches deep.

#### UPPER FLOORS.

**194.** When double floors are used, as should always be the case in the better class of dwellings, the upper or finished floor should not be put down until the plastering is thoroughly dry and most of the standing

finish in place, and when hard wood floors are used they should not be laid until all the other carpenter's work in the room is finished.

When there is to be only a single floor it is customary to lay the floors that are to be carpeted, before plastering, leaving the hard wood floors or those that are to be finished until after the plastering is dry.

*Woods Used for Flooring.*—For floors that are to be carpeted spruce boards are commonly used in New England, while in the Middle and Northwestern States pine is generally used. In the Trans-Mississippi States and in the Southern States hard pine is more commonly used. For kitchen floors, and wherever a good wearing floor is desired without going to the expense of hard woods, Southern yellow or Georgia pine may be used, culling out all boards containing sap or large streaks of dark turpentine, as the turpentine soon crumbles away, greatly marring the appearance of the floor. For floors that are subject to a great deal of wear, maple is generally considered the best wood, while for parlor and hall floors oak or parquetry flooring is generally preferred. Besides these woods, birch is used in some sections of the country, and it makes a very pretty flooring. For all floors that are not to be carpeted *quarter-sawed* flooring should be specified, as bastard boards will *sliver* and warp.

*Matched Flooring.*—If only a single floor is used it is absolutely necessary that the boards be matched to prevent currents of air from coming up from the spaces between the beams, and for oak or other ornamental floors it is also necessary that they be matched, so that they may be blind nailed. For other floors matching is not really necessary, and in New England it is not customary to match any but hard wood flooring. Instead of matching the spruce and hard pine flooring the boards are carefully jointed or planed so that their edges will come tightly together and the nails are driven in from the top and sunk with a nail set, if the floor is to be dressed off. This makes a better floor than the ordinary matched flooring. In the Western States nothing but matched flooring is seen, although a great amount of the flooring is so poorly matched that it cannot be made to come together without rejoining by hand.

*Widths and Thickness.*—For a floor that is not to be carpeted the width of the boards should not exceed 4 inches,\* and for a first-class oak, maple or birch floor 2½-inch flooring should be specified. For carpeted floors 6-inch widths will answer, if a good quality of soft

---

\* Flooring is commonly designated by the width of the board from which it is stuck, 4-inch jointed flooring, measuring about 3¾ inches, and matched flooring, 3-3-16 inches on top.

pine or well-seasoned spruce is used, otherwise 4-inch flooring should be specified, for if a 6-inch board warps much it will form ridges which will cause the carpet to wear at those places. Ordinary flooring is  $\frac{3}{8}$  of an inch thick, the bottom side being left rough, but for stores, public corridors and similar places  $1\frac{1}{8}$ -inch flooring should be used, both for stiffness and durability.

The better qualities of matched flooring are usually grooved on

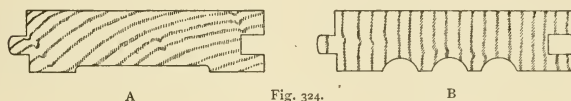

the under side, either as at *A* or *B*, Fig. 324, to make it conform to the floor and to prevent warping.

**195. Qualities of Flooring.**—Soft pine and spruce floorings are made in two qualities, first and second, the first quality being free from knots, while the second quality contains small sound knots. Second quality pine flooring will answer for floors that are to be carpeted, but only the first quality of spruce should be used for a good residence, if used at all.

Hard pine stock flooring is sorted into three qualities, quarter-sawed, first and second clear, and star. First and second clear flooring would be furnished for “first quality” unless “quarter-sawed” is specified.

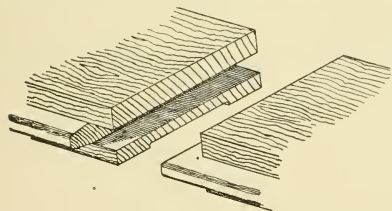

Even the quarter-sawed flooring commonly carried in stock is usually so poorly jointed and of uneven width, that it cannot be laid so as to

make a perfectly tight floor. If one wishes a perfect hard pine floor, the specifications should require that the flooring shall be stuck from clear quarter-sawed boards, *after* they have been kiln-dried, and in uniform widths.

There are a few mills in the Northwest that make a speciality of finely matched and polished maple flooring, and if the architect desires a fine floor he will do well to specify flooring from one of these mills.

Especial pains are taken with the matching of this flooring, the tongues being wedge-shaped or rounded, and the boards of a per-

fectly uniform width. The boards are thoroughly kiln-dried and the surface polished.

A few mills also make end-matched flooring, as shown in Fig. 325, which makes a more even joint than the butt joint, and does not have to be nailed through the top. With end-matched flooring it is not necessary to have the joints come over a joist. End-matched flooring is made principally in 3-inch widths, showing  $2\frac{1}{4}$  inches on top.

**196. Laying and Nailing.**—Floor boards should be laid in courses, beginning at one side of the room and each course, if matched, extending the full length of the room. The heading joints should always be cut so as to *come over a beam*, and in matched flooring they should break joint in every course.

In laying matched flooring the boards are generally *blind nailed* by driving the nails diagonally into the upper angle formed by the tongue and the outer edge of the board, as shown in Fig. 326, the



Fig. 326.

inner edge of the board being held by the tongue of the board against which it is driven. In laying the flooring in this way it is obvious that each board or course must be driven up and nailed before the next course can be nailed. The boards should be matched so that they will all be of exactly the same width and fit tightly together, and should be nailed at every bearing, using eight-penny floor nails for  $\frac{3}{4}$ -inch flooring and ten-penny nails for  $1\frac{1}{8}$ -inch flooring. At the butt joints the nails should be driven through the boards after the floor is laid.

In laying plain jointed flooring it is customary to make straight end joints through three or four courses before the joints are broken, and instead of laying one board at a time several boards are cut and laid in position without nailing and are then strained tightly together by means of flooring clamps or wedges, when the outer board is first nailed, and the other boards afterwards.

With jointed flooring the nails must be driven through the board and sunk with a nail set, if the floor is to be dressed off. A pencil line should be drawn with a straight-edge above the floor joists so that the nails will enter the joists and also be driven in straight lines across the floor; two ten-penny flooring nails should be driven at each bearing. Jointed flooring can be laid with closer joints than common matched flooring.



*Traversing.*—Floors that are to be finished in oil, wax or varnish should be *traversed* by hand, that is, planed crossways of the boards, so as to bring the floor to a perfectly plane surface. Special planes with long handles are made for this purpose. For floors that are to be carpeted it will be sufficient to simply plane off all ridges made by the edges of the boards.

*Kiln-Drying.*—All hard wood flooring, and all soft wood flooring that is to be finished, should be thoroughly kiln-dried (see Sections 12 and 13) and should be laid as soon as possible after it is delivered, and should not be delivered until the plastering is *thoroughly dry*.

Flooring that has been well kiln-dried is often put into a damp building and allowed to remain several days before it is laid; under such conditions the wood rapidly absorbs the moisture in the air and all the beneficial effects of drying are counteracted, so that when the

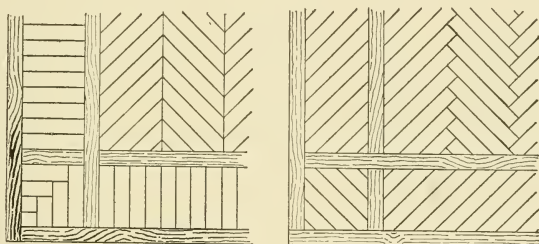

A

Fig. 327.

B

building gets well dried out the floor boards will be found to have shrunk, leaving wide cracks between the boards. This is an important matter in securing good floors and should be carefully guarded against by the superintendent.

*Hard Wood Floors in Patterns.*—Hard wood floors are sometimes laid with short pieces in ornamental patterns by the carpenter. Fig. 327 shows common patterns that may be laid with ordinary 3 inch matched flooring. The mitre joint shown at *A* is the cheaper, as it does not require matching the ends of the pieces. The joint shown at *B* has a more pleasing appearance, but requires that the ends be tongued and grooved. If the pattern is to be more elaborate than the one shown, it will be more satisfactory to use regular parquetry flooring.

**197. Parquetry.**—This consists of strips and blocks of hard wood, fastened together at the edges and on the back, in slabs of convenient size for laying.

As special machinery and facilities are required for making and joining the pieces, parquetry can be made economically only at works especially equipped for the purpose, and hence should be obtained from a regular manufacturer.

There are several firms in this country that make excellent parquetry, the product differing slightly in the manner in which the pieces are put together, and possibly in the quality of material and workmanship.

Parquetry is commonly made in  $\frac{5}{16}$ -inch and  $\frac{3}{8}$ -inch thicknesses, the latter being usually formed by gluing a  $\frac{1}{4}$ -inch face of hard wood to a pine or hard wood backing, although it is also made of solid pieces of hard wood tongued and grooved and glued together. The latter method, however, is more expensive and is but little, if at all, superior for the floors of dwellings.

The  $\frac{5}{16}$ -inch parquetry is made in slabs 12 or 18 inches wide and 3 or 4 feet long for the centres, and 6 to 24 inches wide and 12 feet long for borders.

The  $\frac{3}{8}$ -inch is made in blocks 12 to 18 inches square, or in slabs 12 to 18 inches wide and 4 feet long, according to the custom of the manufacturer.

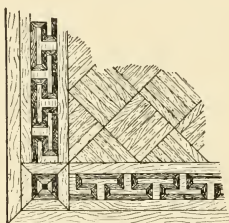

Fig 328.

Both thicknesses may be obtained in a great variety of stock patterns, or any design can be made to order.

A comparatively plain centre, with a border to correspond with the size and finish of the room, is usually the most pleasing.

The pattern, especially in the borders, is usually emphasized or picked out by woods of contrasting colors, nearly all of the hard woods being used for this purpose.

The centre of the floor, however, should usually be either of one kind of wood or of woods of nearly the same color, as oak and maple, these woods being considered the most satisfactory for flooring.

The cost of parquetry flooring varies with the thickness, the elaborateness of the design or pattern, and to some extent with the woods used.

A very handsome floor in parquetry and border,  $\frac{5}{16}$  inch thick,

can be obtained at an average cost of 20 cents per square foot (not including laying). The same pattern  $\frac{3}{8}$  inch thick will cost about twice as much.

*Laying.*—Thin parquetry is usually laid on top of the upper flooring where double flooring is used, and if only a border is provided the centre may be left depressed for the carpet, as the thin parquetry is of practically the same thickness as a good carpet. Thick parquetry is laid on top of an under floor. For either kind the under floor or foundation should be of narrow matched pine boards, well dried out and well nailed. If the floor is in a new building the boards upon which the parquetry is to be laid should be placed diagonally of the room. The upper surface must be made perfectly true and level by traversing, as any inequalities in the foundation will show in the surface of the parquetry. One thickness of good sheathing paper should then be evenly laid over the foundation and the parquetry laid on top, commencing either with the centre or with the border, as may seem best.

The thin parquetry is secured to the foundation by means of  $1\frac{1}{4}$ -inch wire brads if the under floor is of soft wood, or 1-inch brads if of hard wood.

The brads are driven through from the top and counter sunk for puttying, from fifteen to twenty brads to the square foot being used where the pattern is in small pieces. Gluing the parquetry to the under floor is not recommended. The  $\frac{3}{8}$ -inch parquetry usually has a groove in the edges of the blocks into which a slip tongue or spline is inserted, and the blocks are blind nailed as in common matched flooring.

After the parquetry is laid it must be planed, scraped and smoothed with No. 1 sandpaper, rubbing parallel to the grain to get a true and even surface. A special scraper is made for this kind of work, it being very important not to leave any tool marks on the surface of the floor, as the polishing brings them into great prominence.

To obtain a parquetry floor that will not open at the joints, it is essential that the material be thoroughly dry when laid, and almost as necessary that the building be kept artificially heated while the work is being done. Experience has shown that floors laid during those months when the heating apparatus is in use, stand much better than floors laid in the summer months.

**198. Superintendence.**—Although the interior finish of a building is not of such vital importance as the constructive portion, yet

the impressior. which a building makes upon the owner, or the occupants, is largely influenced by the character of the finish and the care exercised over minor details, and the architect or his superintendent should give as much care to the inspection of the finish as to any other portion of the work, and should especially look after all the little things to see that they have not been overlooked by the workmen or improperly done. The young architect should remember that every defect, whether in material or workmanship, is quite sure to be discovered in time, and may reflect seriously upon the person whose business it was to look out for and correct it.

*Inspection of Stock.*—As soon as the stock for the interior work is delivered at the building it should be closely examined for defects, such as sap, knots or pitch, and any defective pieces should be marked in such a way that there will be no chance of their being used. If the superintendent has not entire confidence in the work of the contractor, he should endeavor to ascertain personally if the finish has been dried as required by the specifications, or test it as described in Section 13.

*Doors.*—The doors will of course be made at the shop, and as it is not always possible to tell from the appearance of the completed door whether or not it has been made according to the specifications, a written guarantee should be required for all hard wood doors. A veneered door can be told by examining the edges of the door, where the thickness of the veneer can be seen. The ends of the doors will also generally show how the stiles have been glued up.

*Smoothing Up.*—After the stock for the joiners' work has been inspected it should be carefully smoothed up by hand (unless it has been done by special machinery at the mill), see Section 155, and the superintendent should see that this work is thoroughly done.

*Compare with Details.*—All mouldings, panel work, etc., should be carefully compared with the detail drawings to see that the latter have been carefully followed, and the placing of the door frames so that the doors will swing as shown on the plans should be looked after. It often happens that it is advisable to swing a door in a different direction from that indicated on the plan, owing to a register opening or radiator coming in the way. In such cases the superintendent should consult with the architect regarding the proper change to be made before the frame is set.

The superintendent should also take pains to see that the details for the fittings, etc., will work out properly to fit their allotted place in the building, and that all changes that may be required on account of alterations from the original plans are made.

*Door Frames.*—Door frames should be tested to see that the jambs are plumb and the head level. Frames are often set so that the head is not square with the jambs, which makes very unsightly work and should be guarded against. The superintendent should caution the foreman of the joiners to have the nails driven in the quirks of the mouldings, as far as possible, in putting up the finish.

*Splicing.*—When the casings or architraves for the doors and windows are sent to the building in random lengths, the superintendent should be watchful to see that the carpenter does not undertake to splice them (see Section 171), and it will be well to caution the foreman beforehand that this must not be done. Horizontal finish, such as the base, chair-rail, cornices and picture moulding, must occasionally be spliced, and the superintendent should see that the adjoining pieces are properly matched and jointed. Another thing that should be carefully watched is the putting up of the chair-rail and picture moulding. The joiner often puts these up "by his eye," which is sometimes not very true, so that when the walls are prepared or decorated it will be found that the mouldings are far from level, the fact being made conspicuous by the frieze or pattern of the paper or decoration. The superintendent should test all such mouldings by measuring from the floor or ceiling, or by a spirit level. Before the house is turned over to the painter the superintendent should try all the doors and windows to see that the former swing and shut properly, and that the latter move easily up and down without being loose enough to rattle, and that the sash are properly balanced and hung with the proper cord or ribbon. If any are found that do not work properly he should see that they are fixed before the painters or finishers commence work.

*Stairs.*—The erection of the stairs should be carefully watched to see that they are put up in accordance with the specifications and in a workmanlike manner. If they are built by the Boston method (see Section 186) the carriages should be examined to see that they are put so that the treads will be perfectly level and the risers all of the same height. The workmen sometimes make mistakes in cutting the carriages, and then try to make them answer by tipping them slightly or by adding to the upper and lower risers if they are too short, or cutting a little off from these risers if the carriages are too long. Such misfits should be carefully watched for and condemned immediately if detected, the cost of a new set of carriages being insignificant compared to the harm done to the stairs.

When built by the English method the wedging and blocking up of the finish work from the carriages should be carefully looked after.

As the work draws toward completion the superintendent should carefully read the specifications and make notes of everything that has not been done, or that he is not sure has been done properly, and should have any work that is not properly put up corrected.

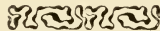

## CHAPTER VI.

### BUILDERS' HARDWARE.

Although it is practically impossible for the architect to keep posted on all that the market contains in the line of "builders' hardware," still it is necessary that he be familiar with the kinds and qualities of hardware in common use, so that he may be able to specify or select such hardware as is best adapted to his purpose and to distinguish between the different qualities. Builders' hardware

may be divided into two classes—rough hardware and finished hardware—the latter being usually designated as "shelf" hardware or trimmings.

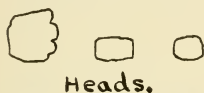

COMMON. CASING. FINISH.  
Fig. 329.—8d. Cut Nails.

#### ROUGH HARDWARE.

The principal forms of hardware in this class come under the head of nails, screws and bolts.

**199. Nails.**—Four kinds of nails are in common use, viz., plate or cut nails, wire nails, clinch nails and wrought nails.

*Cut Nails* are made from a strip of rolled iron of the thickness that the nail is to be and a little wider than the length of the nail, the fibre of the iron being crossways of the strip. Special machinery cuts the nails out in alternate wedge-shaped slices, after which the heads are stamped on them and the finished nails are dropped into the casks.

Cut nails are made in a variety of shapes to suit special uses. For ordinary use in building three shapes are made—common, finish and casing. Fig. 329 gives the exact size and shape of an 8d. nail of each kind. The common nails are used for rough work, finish nails for finished work and casing nails for flooring, matched ceiling and sometimes for pine casings, although the heads are rather too large for finish work.

*Brads* are thin nails with a small head, used for small finish, panel mouldings, etc. They vary from a quarter to 2 inches in length.

*Clout* nails are made with broad, flat heads, and are sold in sizes varying from  $\frac{3}{8}$  to  $2\frac{1}{2}$  inches in length. They are used chiefly for fastening gutters and metal work.

Special nails are also made for lathing, slating, shingling, etc.

*Wire Nails.*—These have of late years become as common as the cut nails, and are sold at about the same price. They are said to be stronger for driving than the cut nails, and not so liable to bend or break, especially when driven into hard woods, and they are also not

as liable to split the wood; for these reasons they are generally preferred by carpenters.

Wire nails are made from wire of the same size as the shank of the nail, by a machine which cuts the wire in even lengths, heads and points them, and also ribs them when desired. Fig. 330 gives full-size engravings of the various styles of wire nails in common use, the same classification in general being used as for the cut nails.

It should be noticed that the gauge of the wire and the shape of the head varies in the different varieties, and that some are barbed while others are plain.

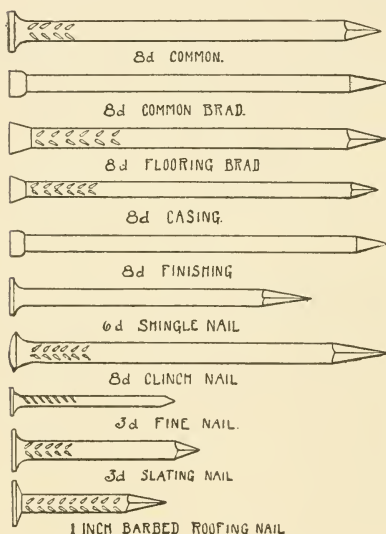

Fig. 330.—Wire Nails (Full Size).

*Clinch nails* are made from annealed cast iron, and are nearly as flexible as the hand-made wrought iron nails. *Wrought* nails are made by hand from the best wrought iron, and cost about four times as much as the clinch nail. Both of these nails are used only in places where it is desired to turn over the ends of the nails to form a clinch, as in the case of battens or cleats.



*Sizes.*—The length of nails is designated by pennies (ds.), which formerly represented the pennyweights of metal in the nail. This designation as to weight no longer holds good, but the designation is still retained and is practically uniform with the various manufacturers, both for cut and wire nails. The weights run from two to sixty pennies, with the lengths given in the following table, the gauge number being for wire nails :

LENGTH OF NAILS.

NAME.	LENGTH IN INCHES.	GAUGE.	NO. TO POUND.*
3d. fine.	$1\frac{1}{8}$	$15\frac{1}{2}$	600
3d. common.	$1\frac{1}{4}$	14	480
4d.	$1\frac{1}{2}$	13	300
5d.	$1\frac{3}{4}$	$12\frac{1}{2}$	200
6d.	2	$11\frac{1}{2}$	160
7d.	$2\frac{1}{4}$	$11\frac{1}{4}$	128
8d.	$2\frac{1}{2}$	$10\frac{1}{2}$	92
9d.	$2\frac{3}{4}$	$10\frac{1}{4}$	72
10d.	3	9	60
12d.	$3\frac{1}{4}$	8	44
16d.	$3\frac{3}{4}$	7	34
20d.	4	6	24
30d.	$4\frac{1}{2}$	5	18
40d.	5	$3\frac{1}{2}$	14
50d.	$5\frac{1}{2}$	3	12
60d.	6	2	10

The length of the various kinds of nails illustrated is the same for the corresponding penny, but the gauge number varies slightly.

*Sizes of Nails for Different Classes of Work.*—Contractors who value their reputation may be relied upon to use nails of proper size, but unfortunately there are many builders who, for the sake of saving a few cents, will use smaller nails than the work demands, and to insure against this it is well in certain classes of work to specify the sizes which are to be used. For framing, 20, 40 and 60d. nails (or spikes) are used, according to the size of the timber.

For sheathing and roof boarding, under floors and cross bridging, 10d. common nails should be used. For upper floors 10d. floor or casing nails should be used for jointed boards, and 9d. or 10d. for matched flooring, although 8d. are sometimes used. Ceiling is generally put up with 8d. casing nails when  $\frac{3}{4}$  inch thick, and 6d. nails when thinner stuff is used.

For inside finish 8d. down to 2d. finish nails or brads are used, according to the thickness and size of the mouldings. For pieces exceeding 1 inch in thickness 10d. should be used.

Clapboarding is generally put on with 6d. finish or casing nails ;

\* These quantities vary slightly with different manufacturers

4d. nails should be used for shingling and slating, and 3d. for lathing. For slating, galvanized nails should be used, and they are also better for shingling.

Whether wire or cut nails shall be used may generally be left to the builder, but in places where there is any danger of the nails being drawn out either by the warping of the boards or from the strain on the nail, *cut* nails should be used, as they have much greater holding power than the wire nails.

From comparative tests made at the Watertown Arsenal of the power required to draw nails when driven to their head in spruce timber, it was found that in the whole forty series of tests (each series comprising ten pairs of cut nails and wire nails of one size), com-

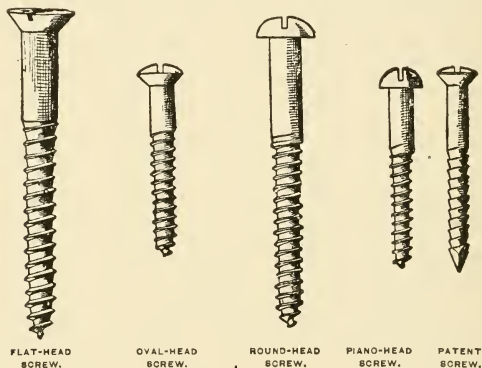

Fig. 331.

Fig. 332.

prising forty sizes of nails, the cut nails showed an average superiority in holding power of 60.5 per cent., the common nails showing an average superiority of 47.51 per cent., and the finishing nails an average of 72.22 per cent. In no series of tests did the wire nails hold as much as the cut nails.

*Copper and Brass Nails.*—Nails are also made of copper and cast brass. They are sometimes used in connection with boat building, refrigerator work, etc. One wing of the Physical Laboratory Building of Harvard College is put together entirely with brass and copper, no iron being used about the construction of the building, as the rooms were intended to be used for delicate electrical work.

**200. Screws.**—The substitution of screws for nails in building operations is a marked feature of modern work. All kinds of trim-

ming hardware are put on with screws, and a great deal of panel work, inside finish, etc., is put together with them. Stop beads, the casings of plumbing fixtures, etc., should be fastened with screws, and also all kinds of store and office fixtures, and cabinet work in general, except where the joints are glued. Screws are also largely used in making furniture. Screws possess the advantage over nails of presenting a neater appearance, greater holding power and ease in

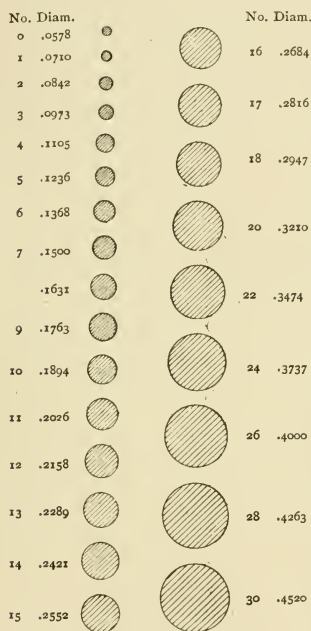

Fig. 333.—American Screw Gauge.

removing without injuring the material. By making holes for the screws with a bit there is also no danger of splitting the finish. The ordinary style of screw has a gimlet point by which it can be turned into the wood without the aid of a bit. The heads are made in four styles to suit different uses, as shown in Fig. 331.

Screws are made of iron, steel, brass, copper, bronze and phosphor bronze; the ordinary screw being of iron. Steel screws are comparatively little used on account of the cost. Brass, copper and bronze screws are used for putting on finished hardware of the same material, the heads being finished to correspond with the trimmings.

Iron screws are also finished with either a blue, bronze, lacquered or tinned surface, to match the cheaper class of trimmings. Blued screws are generally

used with japanned hardware and for stop beads, and wherever a cheap round-headed screw is desired. Silver and gold-plated screws are also manufactured for use in connection with similar hardware.

Iron wood screws are made in twenty different lengths, varying from  $\frac{1}{4}$  inch to 6 inches, and each length of screw has from six to eighteen varieties in thickness, there being in all thirty-one different gauges, so that altogether there are about 250 different sizes of ordinary wood screws in the market.

In ordering screws both the length and number of the gauge (diameter of the shank) should be given. Fig. 333 gives the exact section of the different gauges of American screws.

Fig. 332 shows a patent screw manufactured by the Russell & Erwin Mfg. Co. It has a diamond point and can be driven with a hammer its entire length into any hard wood, and then held by one or two turns as securely as the ordinary screw.

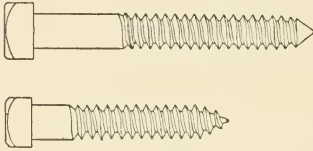

Fig. 334.—Lag and Coach Screws.

Bolts, which are much used by builders. Hand-rail screws are illustrated in Fig. 311.

Lag screws have a conical point, Fig. 334, with deep threads and a square head like the head of an ordinary bolt, and are turned by a wrench. They are made from  $\frac{5}{16}$  to 1 inch in diameter and from  $1\frac{1}{2}$  to 12 inches long. They are considerably used in framing in place of bolts.

Coach screws are similar to lag screws, except that they have a gimlet point, and are not usually made over  $\frac{3}{4}$  inch in diameter.

**Bolts.**—About the only shape of bolt used by builders is the common round bolt with square heads and nuts. Bolts up to 24 inches in length and  $1\frac{1}{2}$  inches in diameter are generally carried in stock by the larger hardware dealers; above that size they are usually made to order. Bolts with button heads, Fig. 335, either round or square under the head, are also carried in stock up to  $\frac{3}{4}$  inch in diameter, and are sometimes preferable to the ordinary square-head bolt.

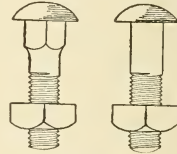

Fig. 335.—Button-Head Bolts.

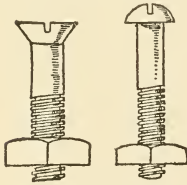

Fig. 336.—Stove Bolts.

Stove bolts are sometimes used in building operations. They are made with flat and round heads, as shown in Fig. 336, and in sizes varying from  $\frac{5}{8}$  to 7 inches in length and from  $\frac{5}{32}$  to  $\frac{5}{8}$  inch in diameter.

#### FINISHED HARDWARE.

**201. Materials and Finish.**—Most of the finished hardware used about buildings is made either of cast iron, brass or bronze, although wrought iron and steel are used to a limited extent.

*Iron.*—Nearly all of the cheaper grades of butts, knobs, locks, etc., are made of cast iron. This material answers very well as far as the durability is concerned, the principal objection to it on this score being its liability to break under a blow or jar. For this reason it is not suitable for bolts, although it is often used for the casing of bolts. It is also not well suited for butts, as it often breaks from an unequal strain or sudden jar.

*Finish of Iron Hardware.*—For the very cheapest class of work the iron is left just as it comes from the foundry, only being cleaned up a little with the file or brush.

The cheapest method of finishing iron hardware is by coating with ordinary black varnish or with japan, the quality of the japanning or varnish depending upon the grade of the goods. Japanning is practically indestructible where the iron is not exposed to scratches or rubbing, and for durability is to be preferred to any of the lacquers or imitation bronzes.

“Berlin bronze,” “Tucker bronze,” the so-called “Boston finish” and nearly all lacquered hardware is finished by heating the iron and immersing it in a bath composed of linseed oil and gum-anime or copal, to which is added powdered alloys of copper and bronze, to give the desired color. When the coating thus obtained is dry the iron is roasted in a kiln, which seems to dry the preparation into the pores of the metal, and leaves it with a smooth, shining surface, imitating more or less closely dull bronze. Hardware treated in this way cannot be polished afterwards, all polishing being done to the metal before it is lacquered.

**202. Plated Iron and Steel Hardware.**—Within the past ten years electroplated iron and steel trimmings have been very extensively used, the plating being now so nicely done that it is impossible to distinguish the finished surfaces from bronze metal.

Nickel-plated iron hardware may also be obtained. This finish, however, is unsuited for nice work, as the nickel will tarnish by exposure to the atmosphere, after which no amount of rubbing will restore it to its original appearance.

As a rule plated hardware is not desirable, except such portions as are not subject to wear, as the plating will wear off in a short time, exposing the black iron beneath. Again, bronze plating and oxidizing is often used on very inferior grades of cast iron hardware, particularly door-knobs, butts, drawer pulls, etc., thereby giving to the uninitiated the idea that he is purchasing a good article, when in fact it may be a very inferior one.

In specifying plated hardware, therefore, the architect should confine himself to those articles that are not subject to wear, and of which the base is known to be of good quality. Plated hardware should not be used where it will be exposed to the weather.

*Bower-Barff Finish.*—The most appropriate finish for iron hardware is that obtained by the Bower-Barff process, which converts the surface into magnetic oxide of iron (by means of heat and superheated steam), in which condition it is absolutely rustless. The color of the iron when polished is a lustrous ebony black, especially appropriate for offices and public buildings and some portions of fine dwellings.

All ornamental wrought iron hardware should be finished in this way.

The regular Bower-Barff process is quite expensive, and is controlled under license by a few firms, The Yale and Towne Co. being the sole licensees for builders' hardware or trimmings.

There are other methods of getting a similar effect on iron goods, and most manufacturers have some such method, but these do not, as a rule, give the rich black color of the regular process, nor are they generally considered quite equal in quality.

A good deal of dead black hardware is finished over bronze; while this looks well at first, it wears off after a time so that the bronze shows through.

**203. Brass.**—The terms brass and bronze are often confounded when speaking of hardware, although the materials are quite different in composition and usually in appearance.

Brass is an alloy of copper and zinc, while bronze is a composition of copper and tin. It has a bright yellowish appearance, and is susceptible of a high polish. It tarnishes very easily and is consequently generally protected by a coat of shellac, which, however, will not entirely prevent it from changing in color. The use of brass for hardware is confined principally to door-knobs, small hinges and bolts, which are usually finished in the natural color of the metal.

To keep brass knobs looking well will require more labor than for bronze.

*Bronze.*—Bronze is more largely used in the manufacture of finished hardware than any other metal. It can be cast with great ease and in the most delicate patterns, and may be finished in a great variety of styles and colors.

The general method of producing the different colors of bronze hardware is as follows: The casting, after being trimmed or chased

as may be necessary, is thoroughly cleaned by immersion in a strong acid bath, followed by one in a weak alkali and clear water. It is then suspended in a bath of hot acids specially prepared with various chemicals to produce certain changes in the color of the metal. When the desired shade is reached the casting is removed, dried in sawdust and rubbed down to an even tone on a buffing wheel. Almost any color or shade can be had with bronze by proper treatment.

The colors thus obtained, however, should not be considered as permanent, as they are merely laid on the surface. Copper, silver, gold and nickel finishes are obtained by plating either bronze metal or over iron and steel that has first been plated with bronze or copper. "Bronze hardware is sure to change in time, no matter how it may be finished, and generally the stronger tones are the least satisfactory in the end, fading out to unpleasant musty hues." For plain, smooth hardware the natural color of the bronze will prove the most satisfactory in the end, as it can always be kept bright by polishing.

The various finishes given to solid, or bronze-plated hardware, differ more or less in color and appearance with different manufacturers, and the manner of designating them also differs. They also vary in cost, the relative cost being somewhat in the following order, plain bronze being usually the cheapest and taken as the standard, and a fixed charge being added for the other finishes, according to the size of the article. The brackets indicate the same price.

{ Light bronze.	{ Old brass, shaded.
{ Brass, natural.	{ Copper, oxidized, streaked.
{ Dark bronze.	Silver, light or mottled.
{ Copper, red antique.	Gold, yellow, red or green tints.
{ Old brass, plain.	
{ Dead black, electroplate.	
{ Nickel.	
{ Silver, dark.	

Both bronze metal and bronze-plated iron goods are made plain and figured. In the cheaper grades of goods the figured or ornamented hardware, particularly door-knobs, is usually a little cheaper than the plain surfaces, and the author's experience has been that in a cheap grade the figured knobs show wear less than the plain knobs. In the better grades of hardware ornamentation adds to the price, although if the ornamentation is artistically designed, not in proportion to the improved appearance.

#### SPECIAL TRIMMINGS.

204. To describe all the special kinds of finished hardware used, or designed to be used, in buildings would be almost an endless task,

therefore only a description of such pieces as are in common use will be attempted.

For those who would like a thorough treatise on the subject, Mr Clarence Blackall's book on "Builders' Hardware"\* is recommended as giving the most complete description (up to the date of its publication) of the varieties and cost of hardware obtainable. Many of the following cuts are taken by permission from this work.

For most architects a careful perusal of the following pages, supplemented by the manufacturers' catalogues and an examination of the different styles and patterns at the local hardware dealers', will furnish all the information usually required. The most valuable information, however, can be obtained only by studying the mechanism of the different styles and observing the way in which they wear. When satisfactory hardware has once been found it will be better to keep to that than to experiment with other makes, although the *best grades* of any of the leading manufactures may be relied upon.

In describing the various pieces of hardware the author has deemed it best to take them up in the order in which they are related to the different parts of the building.

**Door Trimmings.**—The hardware for a single door consists usually of hinges, lock, knobs and escutcheon plates. Outside doors used by the public are also often provided with an overhead check. Double doors require in addition bolts for the standing leaf. Sliding doors are commonly hung on "hangers," and are fitted with lock, flush pull and cup escutcheon plates. Double-action doors should have push and kick plates instead of knobs, and a dead lock if a lock is necessary. Store doors usually have handles instead of knobs, and long escutcheon plates. Doors that are provided with an overhead check are often fitted with a pull handle on the inside and a push plate on the outside, and a dead lock.

Other trimmings may also be required for special conditions, but the above covers the trimmings commonly used. Each of the above kinds of hardware are made in a great variety of patterns and sizes, the more common of which we will try to describe.

**Hinges.**—Hinges proper are divided into two general classes by the hardware trade: First, those that are screwed to the *face* of the door or shutter, which are called hinges, and second, those which are screwed to the butt edge of the door and against the frame, and which are designated as *butts*. The latter are almost invariably used

---

\* Published by Macmillan & Co., New York. Price, \$5.



for hanging the doors in finished buildings, hinges being used principally on stable and out-house doors, blinds, shutters, trap doors, etc.

Spring hinges may also be divided in the same way into spring hinges and spring butts, although the latter are very commonly called hinges.

205. *Wrought Strap and T-Hinges.*—Hinges, proper, used for hanging doors are made exclusively of wrought metal, usually iron or steel, and in practically but two general shapes, viz., those shown in



Fig. 337.—Strap Hinge.

Figs. 337 and 338. For doors hung in a frame it is generally necessary to use the T-hinge on account of the narrow edge of the frame. Where there is room to use the strap hinge, as for trap doors, it should be preferred.

Strap and T-hinges are made in sizes varying by inches from 3 to 14 inches for the length of each leaf of the strap hinge, or of the long leaf of the T-hinge, a 6-inch hinge being the smallest that should be

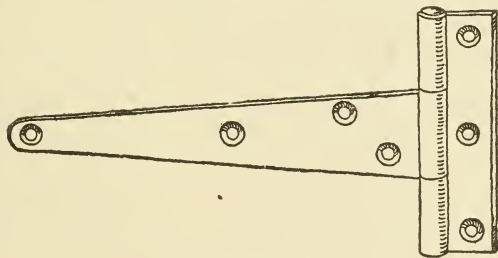

Fig. 338.—T-Hinge.

used for a full-size door. They may be obtained in the plain iron, japanned or galvanized. Wrought hinges cannot be broken without first bending and tearing the iron, and where strength and resistance to rough usage are alone desired, they are preferable to butts. These hinges, however, are more frequently used on battened doors or very thin framed doors, where a butt hinge can not very well be used.

Besides the common strap and T-hinges, shown in Figs. 337 and 338, the Stanley Works make a patent hinge (Hart's Patent) which

has two thicknesses of steel surrounding the pin, as shown in Fig. 339. It is claimed that this hinge has double the strength of the ordinary hinge. The Stanley Works also make corrugated hinges

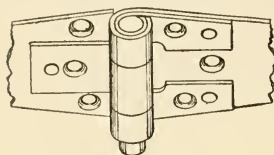

Fig. 339.

(Fig. 340), in which the metal is corrugated about the pin and also on the straps and around the screw holes, which greatly increases the strength of the hinge and prevents the metal from binding upon the pin. They are made of plain steel and with japanned, galvanized or bronzed

finish, and also of wrought brass. They cost a little more than the cheapest wrought hinges and about the same as heavy plain hinges.

This company also makes several patterns of ornamental corrugated hinges in both plated and polished wrought steel and in wrought brass, one pattern of which is shown in Fig. 341. These hinges have a very ornamental appearance, and may be used to advantage on finished work, more especially on cupboard doors, refrigerators, etc.

Single action spring hinges will be described in connection with screen doors.

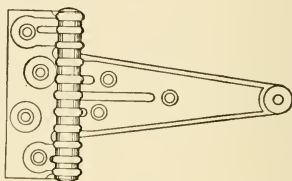

Fig. 340.

**206. Butts.**—All common hinges are made so that the two leaves cannot be separated, the pin being riveted in place, so that the door or shutter cannot be taken off without unscrewing the hinge. This

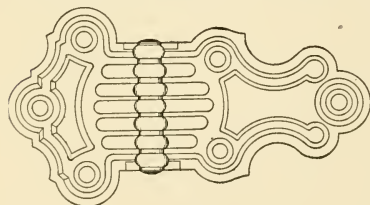

Fig. 341.

would be a very grave objection in the hinges of full-size doors for houses, etc., and the necessity of being able to remove the door without unscrewing the hinge, as well as the question of appearance and safety, has led to the universal custom of hanging

the doors in all finished buildings with hinges like those shown in Figs. 342 and 343, which permit of the door being taken off without removing the hinge. These hinges are called butts, as they are

screwed to the butt edge of the door and the face of the jamb. When the door is closed the leaves of the hinge, and consequently the screws, are concealed, so that the hinge cannot be removed.

Butts such as are shown in Fig. 342 are called *loose-pin butts*, and that shown in Fig. 343 is a *loose-joint butt*.

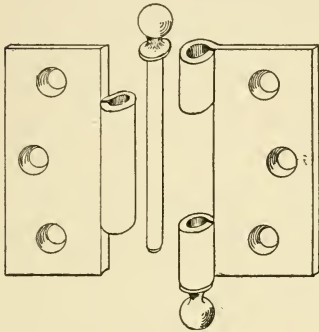

Fig. 342.—Loose-Pin Butt.

Loose-joint butts are finished with and without tips, but loose-pin butts always have them. When hung with the latter butt the door is removed by withdrawing the pins and slipping the hinges apart. With the loose-joint butt all that is necessary is to swing the door so that it will clear the trim, and lift it from the hinge.

The use of these butts varies in different localities. In Boston loose-joint butts are used almost exclusively, while in Western cities only loose-pin butts are used, a loose-joint butt being scarcely ever seen.

Loose-pin butts possess two advantages: The first and most important one is that the bearing surface is increased to a maximum, and as the pin is distinct from the leaves it can be made of a metal that will stand more wear than that of the butts.

The smallest butts have two bearings and three "knuckles," and those 4 inches high and over have four bearings and five knuckles.

The loose-joint butt has only one bearing.

The second advantage possessed by the loose-pin butt, and probably the one which most influences its use, is that as either leaf can be fastened to the jamb, the butt can be used on either a right or a left-hand door, which often saves much inconvenience when hanging the door.

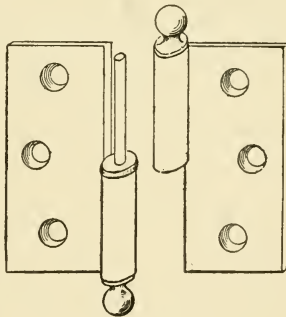

Fig. 343.—Loose-Joint Butt.

With loose-joint butts the part containing the pin must be screwed to the jamb, which necessitates making the butts in rights and lefts. *To tell whether a door is right or left-handed* is often confusing, but if the following simple rule be remembered no difficulty will be found. *Rule:* If the door swings *from* you to the *right*, it is right-handed; if it swings from you to the *left*, it is left-handed.

*For locks* the above rule applies only to doors that *open in*; if the door opens outward, a left-hand *reverse bevel* latch will be required for a right-hand door, and *vice versa*. Reverse bevel latches, however, are usually required only for locks in which the key can be used from the *outside only*, as front door and vestibule locks, rim night latches, etc.

There is another point about the loose-pin butt which is sometimes an advantage and sometimes the reverse, viz.: that by slipping out the pins the door can generally be opened, even when locked. The doors should therefore be hung so that the pins will not be within the reach of burglars or thieves. With the loose-joint butt it is impossible to open the door, when locked, without breaking the lock or butts

Where loose-joint butts are used great pains should be taken to hang the door so that both butts will bear evenly; in many instances it will be found that but one butt carries the weight of the door.

*Material.*—Butts are made of cast iron, malleable iron, wrought steel, bronze and brass. For the very best work solid bronze or brass butts or the Stanley bronze-plated steel butts should be used. The steel butts made by the Stanley Works are very heavily plated and finished so that they can not be detected (when on the door) from solid bronze metal, and the author believes are in all respects as desirable, if not more so (on account of greater strength), as solid bronze or brass butts for the inside doors of dry buildings. As butts are not subject to wear on their face, there is no danger of the plating wearing through.

Front doors, or doors hung in damp situations, should be hung with solid bronze or brass butts, or iron butts Bower-Barffed, or if these cannot be afforded, japanned butts answer very well.

The cheaper grades of butts are made of cast iron, either in the plain iron, japanned, lacquered or plated. A cast iron butt can not be considered as a first-class butt, no matter how expensively it may be finished, on account of the brittleness of the material. If a cheap butt must be used the japanned butt will generally be found to wear the best.

**207. Washers.**—Bronze or iron butts, especially if they have a loose joint, should have the bearing surfaces fitted with some form of steel washer, to reduce the wearing of the bearings. In loose-joint butts the washers are exposed as in Fig. 343; in loose-pin butts the more general custom is to countersink the washers in the hubs of the butt, so as not to show externally. With wrought steel butts washers are unnecessary except for very heavy doors.



Fig. 344.

The Stanley Works have recently patented a ball-bearing washer for their butts, to be used for very heavy doors, which greatly reduces the friction and increases the wearing quality. Two of these washers are used on loose-pin butts (see Fig. 345) and one on the loose-joint butts. The balls are made of the hardest steel and there is no danger of their crushing. An enlarged view of the washer is shown in Fig. 344.

The Yale bronze butts are fitted with self-lubricating steel washers, which are perforated and filled with a non-fluid lubricant, which prevents wear and creaking.

*Sizes.*—Butts are made in sizes varying by half inches from 3x3 to  $5\frac{1}{2} \times 5\frac{1}{2}$ , and above that by inches to 8x10 inches.

Larger than 6x6 inches are seldom used, as it is much better to increase the number of butts rather than the size.

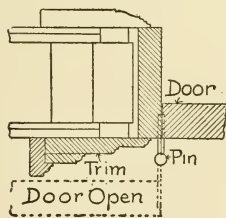

Fig. 346.

butts will not permit the door to spring in the middle.

† It sometimes happens that a 4x4 butt will not allow the door to

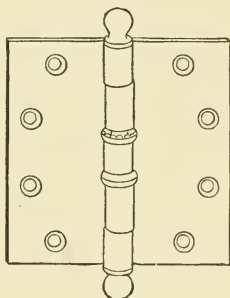

Fig. 345.

In specifying the sizes,  $3\frac{1}{2} \times 3\frac{1}{2}$ -inch butts may be used for  $1\frac{3}{8}$ -inch pine doors not over 2 feet 8 inches wide; 4x4 butts for doors  $1\frac{3}{4}$  inches thick and 7 feet high, and  $4\frac{1}{2}$  or 5-inch butts for heavier doors. Doors over 7 feet 6 inches high should be hung with three butts, and it would be better to hang a 7-foot door with three 4x4 butts than with two 5x5, as the three

swing back parallel with the wall without striking the trim of the door. For such cases butts wider than they are high are made, as  $4\frac{1}{2} \times 4$  and  $5 \times 4$ . The butts should always project beyond the face of the door sufficient to throw the door out beyond the trim, as shown in Fig. 346.

The outside doors of public buildings should always open outward, and should be hung so as to swing back out of the way, and provided with a hook or other means of keeping them open when desired.

**208. Double-Action Spring Butts.**—If it is desired that a door shall swing in both directions, it should be hung with double-action spring hinges. A door pivoted top and bottom near one edge would, of course, swing both ways, but as it is considerable trouble to close a door that does not have a stop, so that it will stay at the proper place, a spring is a practical necessity on all "fly" doors, both to close them and to keep them in the proper position when not being operated. Double-action hinges are especially desirable on

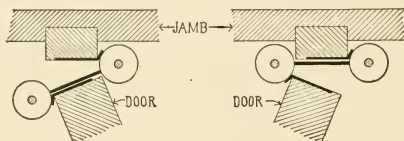

FIG. 347.

pantry doors opening into the dining room, and on vestibule doors in public buildings. They are sometimes used on outside doors of buildings of a semi-public character, but as a double-action door cannot be made tight, nor cannot be so well locked, it is better to use ordinary butts with an overhead door check on such doors.

There are many patterns of double-action hinges on the market, several of them being constructed on the same principle, but differing more or less in slight details and in the quality of the materials. The general principle of nearly all double-action spring butts is that of two pins, one on each side of the door, connected by a central plate which lies between the two leaves of the butt when the door is closed. This is illustrated by the two diagrams, Fig. 347, which show the position of leaves of the hinge for different positions of the door. The principal difference in the various makes of butts, aside from the quality of the materials and workmanship, lies in the arrangement of the spring or springs, which close the door and bring

it to its proper place after being opened. Most of the hinges have two springs (which may be either simple or compound), one around each pin, as shown in Fig. 348, which represents an old style hinge.

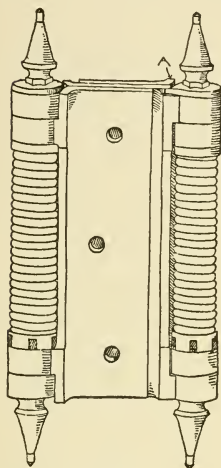

Fig. 348.

As the door is opened the spring about the pin on which the door swings is coiled tighter, and the reaction throws the door beyond the centre, bringing the strain on the other hinge, which reacts in the same way.

All high-class hinges of this type now have the springs concealed within hollow cylinders.

Of hinges of the type described above, the Bommer, American and Oxford are perhaps the most extensively used on good work.

The Bommer hinge is shown in Fig. 349. One flange is screwed to the jamb and the other to the edge of the door, a raised shoulder on the upper and lower edges of the flanges serving as a gauge to the carpenter in putting in the hinge and securing accuracy in fitting.

The peculiar feature of this hinge is the use in the large-sized hinges of compound spiral springs inside of the cylinders, which give a very light and elastic movement, com-

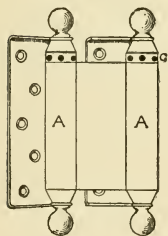

Fig. 349.—Bommer Spring Hinge.

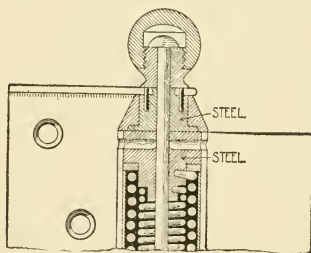

Fig. 350.—Section Through Cylinder of Bommer Hinge.

bined with great power. The construction of the washers also reduces the wear and friction to a minimum. A partial section through

one of the cylinders of the larger sizes, Fig. 350, gives an idea of the construction. This is not a cheap hinge, but may be depended upon to give perfect satisfaction, and to wear almost indefinitely.

These hinges are made of wrought steel, plated, and in bronze metal or brass, and in sizes to fit any door. The bronze and brass metal hinges have a continuous steel core or skeleton running from end to end, and the entire wear is upon this steel interior, not affecting in the least the bronze or brass exterior, and thus overcoming the disadvantages of bearings of soft bronze metal or brass. Single-

action hinges and special patterns for office gates and water closet doors are also made with the same kind of springs.

The American spring hinge is very much like the hinge shown in Fig. 348, except that the spring is encased in cylinders made with six knuckles, resembling the joint of a loose-pin butt. This is a very powerful hinge, suitable for very heavy doors.

The Oxford hinge somewhat resembles in its general appearance the Bommer hinge, but is a cheaper hinge and more suitable for light doors.

Fig. 351 shows the "Chicago" double-acting spring butt, which differs from those previously mentioned in that the force is derived entirely from a single strong coil, working in the thickness of the

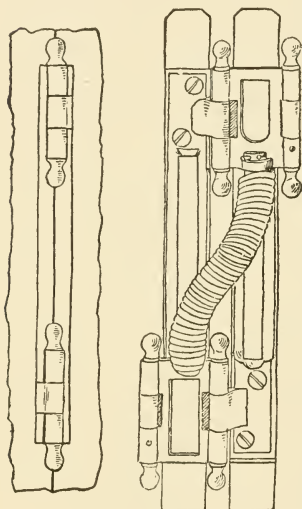

Fig. 351—Chicago Spring Butt.

door, and which is concealed when the door is closed. This hinge is made in japanned iron and bronze metal, and is very extensively used in the Western States. It is neat in appearance and has proved quite satisfactory for doors of average size.

The Oxford and Chicago spring butts are often used with one spring butt and one "blank" to a door, the blank working in the same way as the spring butt, but having no spring. The blank is used to reduce the cost.



209. *Pivot Hinges.*—In the opinion of the author, the handsomest hinge for double-acting doors is the New Idea double-acting spring hinge, shown in Figs. 352 and 354. This hinge is entirely dif-

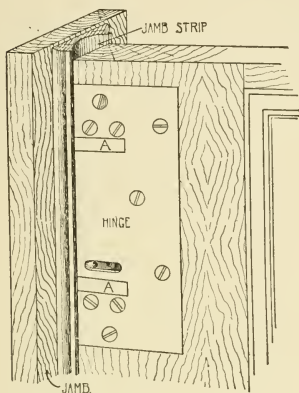

Fig. 352.

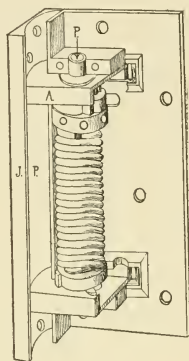

Fig. 353.

ferent in principle from all other spring hinges, as the door really swings on a pivot or pintle, which is supported by the arms (*A*) of the jamb plate, Fig. 353, and let into the door, so that nothing but the face plates and the arms of the jamb plate are exposed. With this hinge a concave jamb strip must be used, as shown in Fig. 352; this strip, however, is more ornamental than the plain strip commonly used, and the joint between the door and strip is much closer than is possible with other double-acting hinges.



Fig. 354.

The leaves of the hinge that are fastened to the door divide on the line of the pintle for convenience in applying; this also allows of two finishes on one hinge. Besides the plain hinge shown in Fig. 352, an ornamental hinge is made, as crudely indicated by Fig. 354, which is, in fact, a very handsome hinge. Aside from the ornamentation this pattern differs from the plain one in that the jamb plate has moulded edges which are exposed, the wooden jamb

strip being made of the same profile and cut against it. Although it has been advertised but little, this hinge appears to have met with much favor from architects.

Some years ago the Bardsley checking spring hinge was quite extensively used for double-acting doors in first-class buildings. This hinge is really two pivots, one fitting into a socket mortised into the top of the door, while the lower one works in connection with a spring encased in a cylinder and sunk in the door sill. The cylinder containing the spring is filled with oil, which prevents any jar or sudden movement. This device works very nicely, closing the door without slamming. The author understands, however, that it has been largely superseded by overhead checks of the liquid type.

The Russell & Erwin Manufacturing Co. also make a double-acting ball-bearing floor hinge with which both the top and bottom of the door are pivoted.

**210. Sliding Door Hangers.**—Sliding doors are now almost always hung from the top by hangers which roll on a track secured to the inside of the studding or hung from the header above the opening and pocket.

There are a great many styles of hangers and several kinds of tracks in the market, and it is often puzzling to the architect to know what to specify.

With any hanger that rolls on a track, the most important considerations, aside from strength, are the friction of the hanger on the axle, and, if on a fixed track, a practical arrangement for adjusting without taking off the door; the matter of noise is also

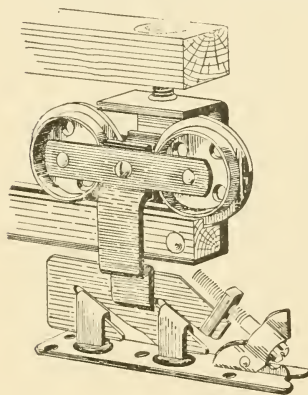

Le Roy Hanger.  
Fig. 355.

an important consideration with house door hangers. The track, also, is nearly if not fully of equal importance with the hanger; it should be straight and capable of adjustment in case the studding to which it is attached should settle.

In most of the hangers the friction is reduced by permitting the hanger to roll on the axle while the wheels of the hanger are rolling on the track, although several of the latest devices have ball or roller bearings.

One of the best combinations of track and hanger that the author has yet seen is that of the Le Roy Noiseless Ball-Bearing House Door Hanger, with adjustable track, shown by Fig. 355, a better view of the track being shown in Fig. 366. As will be seen the track consists of a grooved strip of hard wood  $1\frac{1}{4}$  inch by  $1\frac{3}{8}$  inch, which is riveted to a  $1\frac{3}{8}$  inch by  $1\frac{1}{2}$  inch steel angle. The track is secured to a wood header above by steel brackets riveted to the track and secured to the header by adjustable screws. For parlor doors the track is made stationary at the ends in the pockets, and is adjusted at the center of the opening. In this way any settlement in the partition can be readily overcome.



Fig. 355A.

The wheels of the hanger have a raised rim which fits into the groove in the track, so that they cannot possibly get off the track, and at the same time each wheel has a bearing on each side.

The wooden track practically does away with all noise, and the manner in which the door is suspended from the trolley causes it to hang perfectly. The axles of the wheels have ball-bearings which reduce the friction to a minimum.

The doors can also be slightly raised or lowered by an adjusting screw on the bottom of the hanger.

The wooden header shown in Fig. 355 is furnished with the track, so that the putting up of the track is a very simple matter.

This track and hanger requires a clear space of 4 inches between the studding, and a vertical height of  $8\frac{1}{4}$  inches from the top of the door to the top of the track header shown in Fig. 355.

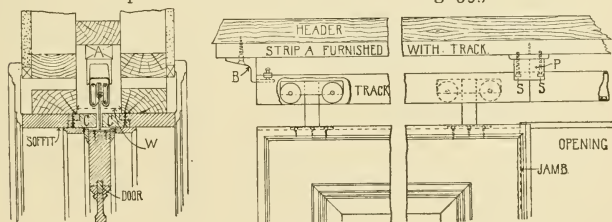

Fig. 356.

*Trolley Tracks.*—Another very satisfactory arrangement for hanging sliding doors is by means of a trolley track, similar to that shown by Fig. 355A. The trolleys or wheels which carry the door run inside

of the track as shown in Fig. 356. The track being of rolled steel possesses a great deal of strength, so that it requires but few supports and can readily be adjusted. With this track it is absolutely impossible for the wheels to get out of place, or for any dirt to get inside of the track. It also requires less space between the studding than other tracks, 3 inches being sufficient for doors  $1\frac{3}{4}$  inch thick. Several grades and kinds of hangers are made to suit different requirements.

The trolley track is especially well adapted for large doors or sliding partitions which have to slide some distance. In such cases it will be best to place the doors outside of the partition and incase the track in a false beam or cornice, so that it can be easily got at for adjustment.

Trolley tracks and hangers for a variety of purposes are made by the Coburn Trolley Track Manufacturing Co. and by the Wilcox Manufacturing Co, the principle of construction being practically the same in each, while differing in the details. (See also page 351.)

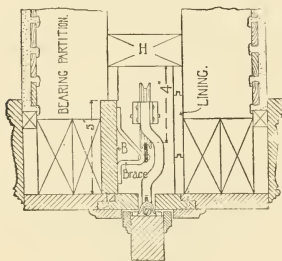

FIG. 357

perfectly level and securely nailed to the studding. A plank, *H*, should be securely nailed between the two lines of studs, a sufficient distance above the track to keep the space of uniform width, prevent the studs from springing and to protect the wheels and doors from dropping plaster. The track being of steel cannot warp, and being attached to but one side of the partition is not subject to derangement from unequal settling of the two sides of the partition.

The single track is now used by several manufacturers, that and the trolley track having almost displaced the double wooden track, unless it be in the cheaper buildings.

The hangers used on these tracks require an accessible and practicable means of adjustment, so that either the front or back edge of the door may be raised in case the bearing partition settles, and an

211. Next to the trolley track the author would place the single iron bar track, one type of which (the Lane) is shown in Fig. 357. The track is placed directly over the centre of the door and is attached to a board by means of iron brackets riveted to the track and screwed to the board or track plate. This track plate should be in one piece the full length of the track, and of well-seasoned pine, and should be put up

anti-friction provision for the wheels. The method of adjustment varies with each make of hanger, but a great many have an adjustment somewhat similar to that shown in Fig. 359, which works very well for the front edge of the door, but can not so readily be got at on the back edge. This adjustment also necessitates right and

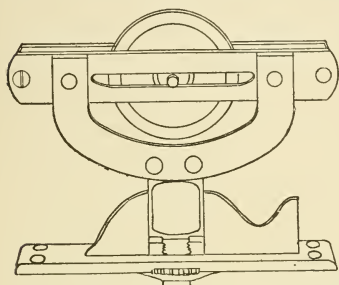

Fig. 358.—The Lundy Hanger.

left-hand hangers. Several hangers are adjusted by means of a serrated screw, as in Figs. 358 and 360.

Previous to the introduction of the roller and ball-bearing hangers the provision for anti-friction had generally consisted in permitting the axle of the wheels to roll in a slot in the hanger carriage, as shown in Fig. 358, and this has been found

to give very satisfactory results for parlor doors. If a door has to slide a long distance, however, this arrangement becomes impracticable on account of the great length of slot required. For ordinary parlor or barn doors, however, a sufficient length of slot can easily be provided, and hangers of this style are much to be preferred to cheap roller or ball-bearing hangers. In fact, it is generally admitted that there is no bearing so poor and unreliable as a poor quality ball-bearing. A ball-bearing hanger, therefore, that is sold for a less price than the standard hangers, should be looked upon with suspicion. Roller bearings are more durable, as the rollers, when of the same quality, have a greater crushing resistance.

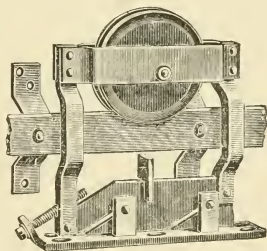

Fig. 359.—Lane Ball-Bearing Hanger.

Fig. 359 shows the Lane single rail, ball-bearing parlor door hanger, which is the same as their standard hanger except in the bearing, the Standard hanger having a slot bearing similar to that in the Lundy hanger. The ball-bearings in the Lane hanger have cups and cones carefully made and hardened, and polished steel balls guaranteed not to crush; the quality and workmanship being equal to that in high-grade bicycle bearings. This

bearing adds slightly to the cost of the hanger, as well as to its working quality and durability. Ball-bearing and roller-bearing hangers are, of course, adapted to any length of track.

The "New Model" Lane parlor door hanger, shown in Fig. 360, represents, perhaps, one of the best of the low-priced hangers, the reduction in cost being due to a less amount of material in it and somewhat less labor. It has roller bearings running on a hard steel bushing. The adjustment is made by means of a nut with serrated projections or flanges both above and below the fastening plate, so that the nut may be turned either from the edge of the door above the plate or from the side by removing the stop.

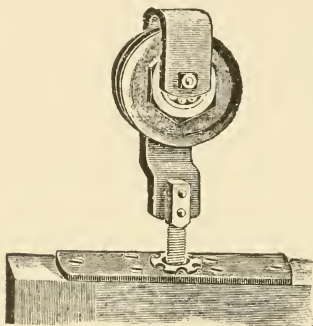

Fig. 360—Lane New Model Hanger.

When parlor door hangers were first introduced two tracks, generally of wood, were used for the hangers to run on, and several double-track hangers are still used. As has been stated, the principal objection to a double-track hanger is that the two sides of a sliding door partition are very apt to settle unequally, thus leaving the tracks at unequal heights and interfering with the proper working of the hanger. As long as the tracks are on a level, however, double-track hangers work fully as well as the single-track hangers, and if there were no chance of the partition settling, the double-track hangers would be preferable.

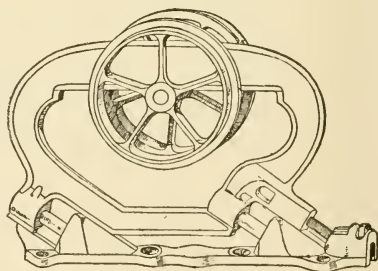

Fig. 361.—Richard's Hanger for Wood Tracks.

Fig. 361 illustrates one of the better types of double-track hangers. *Barn doors* are now generally hung from an overhead track in

much the same way as house doors, except that the hanger, being exposed, is commonly screwed to the inside of the door.

Most of the manufacturers of parlor door hangers also make barn door hangers that work in about the same way as their house door hangers. The Coburn trolley barn door hanger has the same form of track as that shown in Fig. 355, varying in size to correspond with size and weight of the door, and the hangers are of the same general pattern, although the manner of attaching to the door is entirely different, and a lateral adjustment is provided so as to move the door sideways in case it should warp and bind against the wall. The trolley track is especially suitable for places where the track is exposed, as nothing can possibly get into it and it requires no hood.

The Lane barn door hanger and track is very similar to their standard parlor door hanger, and works very satisfactorily.

Barn doors, when hung at the top, should be provided with one or more stay rollers at the bottom to prevent their being blown in.

**212. Trackless Hangers.**—Besides the class of sliding door hangers that roll on a track, there is also a distinct type of hangers which operate the door by means of a frame working on the principle of a parallelogram, the corners of which must always be at the same level. This frame is attached to the back edge of the door and the door slides by it.

The first hanger invented of this type was the *Prescott Brace Hanger*, which was placed on the market during the year 1880, and at once gained considerable popularity, due to the great ease and smoothness with which it works. Since then this hanger has been quite extensively used for hanging parlor doors, elevator doors and the large doors of stables, warehouses, freight sheds, etc. The form of hanger used for doors 4 feet and under is shown in Fig. 362. As may be seen, it consists essentially of two flat bars joined scissors fashion in the centre. The lower end of the bar *X* is fastened by an angle iron to the *face* of the jamb stud, as shown at *A*, and the lower end of *Y* is fastened to the back edge of the door in the same way. The upper end of each bar has a pulley which works between two parallel bars attached, one to the face of the jamb stud at *E*, and the other to the back edge of the door at *D*. The weight of the door comes principally upon the pivoted hinges at *A*, *B* and *C*. When the door is opened the hanger spreads out like a pair of shears, at the same time raising the door about  $\frac{1}{4}$  inch, and as the door is closed the hanger shuts up until the two bars are parallel. In practice, the hanger, when properly set, works to perfection. The door can

never bind, but can be operated by the slightest pressure in either direction. The doors are hung after the plastering is done.

An objection to the use of this hanger in parlor doors, however, is that it requires a wider pocket than the track hangers and it is necessary to remove the jambs in order to adjust it in case of settling.

Where the hanger is exposed, as on elevator doors, barn doors,

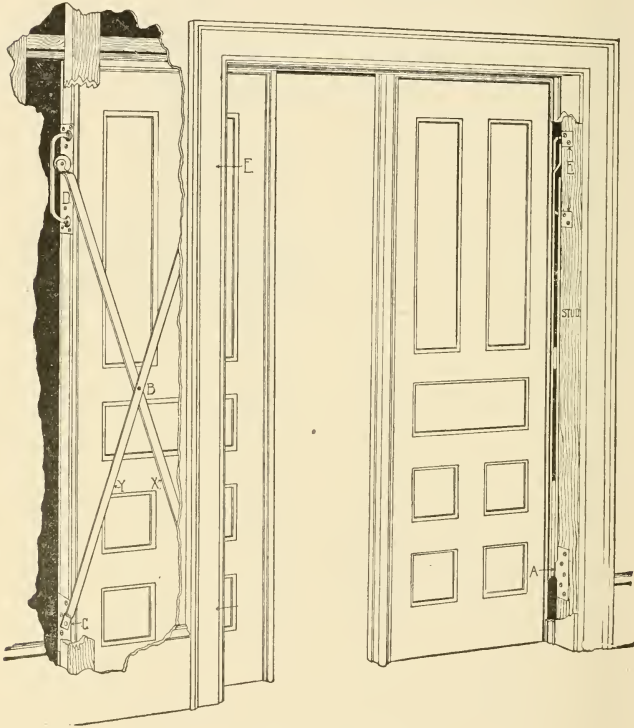

Fig. 362.—Prescott Door Hanger.

etc., it may be used to great advantage, as it works with the greatest ease, however large or heavy the door may be. This hanger has been found especially serviceable on elevator doors, as it permits of an opening the entire width of the car when desired. This is ob-



tained by hanging a door across half of the opening with ordinary butts, and closing the rest of the space by a door hung with Prescott hangers to the first. The sliding door can then be operated in the usual way for passengers, or both doors may be swung on the butts to give the full opening for taking in boxes, furniture, etc.

For wide doors a compound hanger, consisting of two single hang-

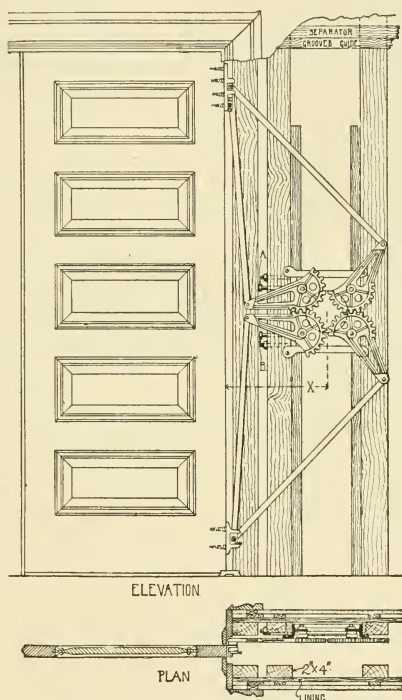

ers joined by bolts, is used, and for very heavy doors the bars are trussed, the operation being essentially the same as with the single hanger.

*The American Trackless Door Hanger*, shown in Fig. 363, is, the author believes, the latest device in the way of a trackless hanger,

and is especially designed for doors intended to slide into a pocket. As may be seen from the illustration, it consists of four arms pivoted at four points, the centre of the hanger being placed just one-half of the width of the door back from the jamb, so that when the door is pushed clear back, the position of the arms is exactly reversed. The arms work in the pocket between the door and the studding, as shown by the plan. The width of pocket between studding should be 3 inches plus thickness of doors.

The moving gear is attached to a rectangular cast iron frame, screwed to the studding in such a way that it can be adjusted or re-

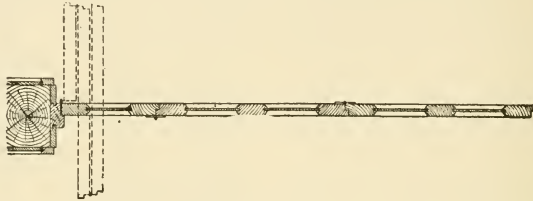

Fig. 364.

moved from the pocket without disturbing the plastering, the adjustment being done entirely by turning the two bolts *A* and *B*, which are easily accessible.

It is claimed that the operation of this hanger is noiseless and extremely easy, and that the hanger can be put up in less time than is required for overhead hangers. Trackless hangers have the advan-

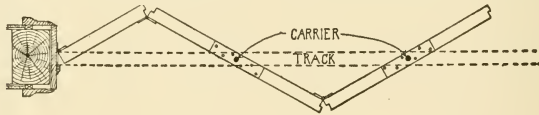

Fig. 365.

tage that no opening in the head jamb is required and no overhead work.

**213. Hanging Folding Doors.**—It is sometimes necessary to close wide openings between adjacent rooms with folding doors. The common custom in such cases has been to make the doors or folds which close the opening of uniform width, the outer doors being hung to the jambs and carrying the adjoining folds as with shutters. Where one door is hung to another, however, the doors are quite sure to sag, and to make the doors work easily a heavy castor should

be put under the carrying edge of each fold, so that the door may roll on the floor as it swings.

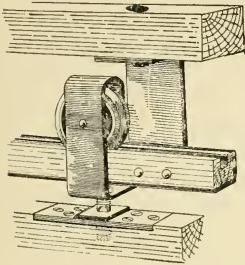

Fig. 366. Wilcox Swivel Hanger;  
Ball-Bearing.

For closing wide openings, separated by posts, the author has found it an advantage to divide the doors, as shown in Fig. 364, the folds next the jamb being but one-half the width of the middle folds. By making the outer folds narrow there is not the leverage on the jamb hinges that there is with wide doors, and the doors are not so apt to sag. When divided in this way the doors do not come as much in the way when open as they do when all

the folds are of equal width.

The butts for the folds next the jamb should be of the best quality of steel (plated as desired), and 5 or 6 inches high, but not more than 4 inches wide for a  $1\frac{3}{4}$ -inch door.

When there is room for a track above the doors, they may be suspended at their centres by swivel carriers rolling on an overhead track the same as used for parlor doors, the doors turning on the swivel as they are folded, as indicated in Fig. 365. The Wilcox Manufacturing Co. makes a special carrier for this purpose, which works very satisfactorily.

When doors are hung as in Fig. 365 it is necessary to use hinges

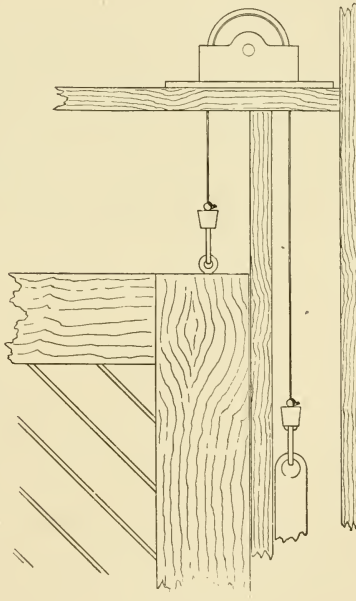

Fig. 366a.

similar to the one shown in Fig. 341, screwed to the face of the door, instead of butts, and at least three hinges to a fold.

**Balanced Doors.**—The outside doors of freight elevator shafts and also of freight sheds are usually hung to slide up and down, as there is not generally room for swinging doors. When the expense will permit, self-coiling steel shutters or doors are considered as the best means of closing such openings, but for ordinary mercantile buildings, large single doors balanced by weights are more commonly used.

Balanced doors should preferably be hung from overhead pulleys, as in Fig. 366a, with either metal bands or sash chains for connecting the weights with the door. The Gardner Sash-Balance Co. makes an 8-inch roller bearing overhead pulley, by means of which, and their metal sash ribbon, doors weighing up to 500 pounds may be raised or lowered with ease.

#### LOCKS.

**214.** There is such a variety of locks for securing the doors of buildings now manufactured and on sale by hardware dealers, that it will be impossible to describe all of the different patterns, and an attempt will be made to describe only the principal features common to most locks, with the manner in which they work, and some of the special styles of locks with which the architect should be familiar.

**Construction and Operation.**—In regard to their construction, locks may be classified as “tumbler locks” and “cylinder locks,” and as “rim locks” and “mortise locks.” Rim and mortise locks, however, differ only in the shape of the case, a rim lock being made to be fastened to the face of the door, while the mortise locks are set into a mortise cut in the stile of the door, the internal construction being the same in both locks.

*Tumbler Locks.*—Tumbler locks are the common kind of locks operated by an ordinary key, and so called because the security of the lock depends upon tumblers or levers, which must be raised to an exact position before the bolt can be thrown. These locks also differ a great deal in some of their details, and also in the manner in which they are made. Most of the locks in common use have cast iron cases and cast bolts, with only the springs and tumblers of wrought metal, and even the tumblers are of cast iron in some of the cheaper locks. In the very latest patterns of tumbler locks, all of the parts, including the case, are made of wrought metal by means of the drop forge which cuts and stamps the parts to the desired shape,

and as these locks merit a special description, they will be described in another section.

The ordinary tumbler lock consists essentially of the following parts: 1. The case, which contains the works, and to which the *wards* and *guides* are attached. 2. The bolt. 3. The levers. 4. The catch with its accompanying springs. 5. The hub, and 6 the key. The hub and catch are not a part of the locking apparatus, and many locks have no latch, but they form a very important part of the ordinary house door lock. The knobs and spindle might also be given as a part of the ordinary lock and latch, as they are necessary to operate the latch.

To enable one to understand the general principles upon which a tumbler lock is constructed, and also the features that effect the

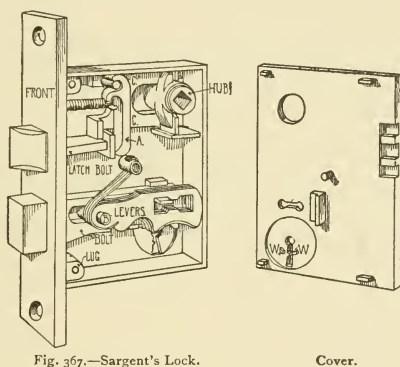

Fig. 367.—Sargent's Lock.

Cover.

quality of a lock, a short description of the various parts and the way in which they operate is given.

The case is usually made of cast iron, left comparatively rough for mottised locks, and finished, usually in japan, for rim locks. A few of the old style or cast locks have cases pressed out of cold rolled steel, but perfectly plain.

The cast case is made in the form of a shallow box, as in Fig. 367, with a flat cover, fastened in place by a screw. The front of the box is usually of a separate piece of brass or bronze metal, secured to the case by lugs and rivets. In the very cheapest locks the face is of iron cast with the case.

Most cases have a post, *B*, cast with the box part, and also guide for the latch bolt.

*Wards.*—On the inside of the cover of the case near the keyhole a small projection, *W*, Fig. 367, is commonly cast, necessitating a corresponding cut in the sides of the key to allow it to turn. This projection is called a ward. In ancient locks the wards were made quite elaborate, and much dependence was placed upon them for the security of the lock. While it is true that

wards prevent the use of any ordinary key not made to fit the lock, they do not interfere with the picking of the lock by an experienced lock picker, and in the better grades of locks they are now usually omitted.

Another device to prevent using any but the right key in the lock, often seen on cheap locks, is a projection on the side of the keyhole, as shown in Figs. 367 and 370.

The projection requires a corresponding depression in the face of the key, but as ordinarily made, this is no safeguard against burglars, as a thin key can be slipped by the projection, or the projection, being of cast iron, can easily be broken off. A professional lock-picker, however, generally uses pieces of stout wire to operate the lock, and against these wards and keyhole projections are no protection.

The bolt which secures the door is generally made quite heavy where it projects beyond the face plate, but is thinned down inside the lock so as to be as light as possible and to give space for the levers. The general shape of the common cast bolt is shown in Fig. 368. The notch *A* is where the key catches, the post *B* is the part which catches in the levers, and the slots *C* fit over a guide post on the case. Fig. 369 shows the dead bolt of the Yale locks with solid bronze head and steel tail piece forged together.

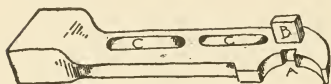

Fig. 368.—Cast Dead Bolt.

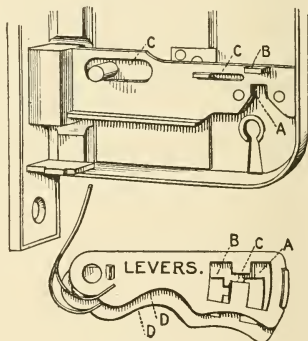

Fig. 369.—Dead Bolt and Levers of the Yale "Vulcan" Lock.

In all the best grades of cast locks the bolt is of brass or bronze, an iron bolt being too easily broken.

**215. Levers.**—The levers or tumblers, the terms being used synonymously, are flat pieces of iron, steel or brass, usually fitted with a spring (Fig. 369), which are so arranged in the lock that the bolt cannot be shot without lifting the levers, which can only be done by a key of the proper size and shape.

There are from one to five levers in an ordinary lock and they are usually placed one over the other and pivoted over the guide post, as shown in Fig. 367. The bolt post is so placed as to fit in the cut *A*, Fig. 369, when the bolt is thrown back, and in *B* when thrown open. The connecting gatings *C* are cut at different heights so that the levers must be lifted unequally in order to permit the bolt to move. When the key is turned in the lock the cuts in the bit of the key, which are made to match the levers, bear against the bellies *D*, lifting the levers simultaneously until the gatings are exactly on a line with each other. The key then catches in the notch in the bottom of the bolt, the bolt post passes through the gatings and the levers drop as the key turns, catching behind the bolt post and effectually preventing the bolt from being forced back.

There are many different arrangements of the levers and sometimes more than one set is used, but the general principle is the same in all lever locks. It is obvious from the above description that the more levers a lock has the greater will be the security afforded, and, in fact, the only real security afforded by the common tumbler lock is in the levers. A one-lever lock offers little security, while a three-lever lock offers ten times the security of a one-lever lock.

By transposing the levers and changing the height of the gatings a great many changes can be made, no two of which can be operated by the same key.

*The latch* is in reality a spring bolt with a beveled face intended to keep the door closed when shut into the jamb, and is operated by the knobs. There are three distinct kinds of latches in common use, the simple spring latch, the anti-friction latch and the stop or front door latch.

Nearly all of the later patterns of locks have an "easy spring" action for the latch bolt, which, although somewhat different in different makes, usually consists of an arrangement of two springs, only one of which is brought into action when the door closes, while both resist the turning of the knob. This permits the latch bolt to be easily pushed back, and at the same time holds the knob firmly.

This is more clearly shown by Fig. 370. When the latch bolt is thrown back by striking the plate on the door jamb it is resisted only by the light spiral spring around the shank of the bolt, but when the

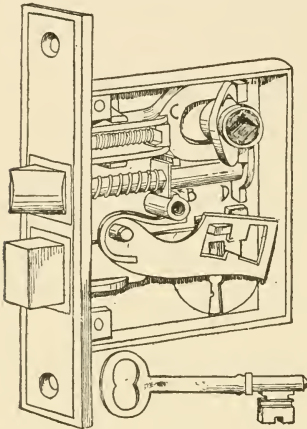

Fig. 370.—Lock and Latch.

hub is turned it moves forward the carriage *C*, and also the plate *D* on the end of the latch, thus bringing into play the stronger spring in the carriage and also the lighter one on the bolt.

In Fig. 371 (which represents the knob action of the Yale "Vulcan" locks) the spring *A* alone opposes the latch when pushed back, but when drawn back by the hub both of the springs *A* and *B* are acted on.

In the Sargent lock (Fig. 367) but one spring is used, the "easy" action being obtained by means of the long lever *A*, which offers but slight resist-

ance to the latch bolt, while the turning of the hub, which draws back the carriage *C*, is directly resisted by the strong spiral spring.

Most lever locks are now made with reversible latches, the latch shank being of such shape that it may be turned over so as to be used for either a right or a left-hand door.

*Anti-Friction Strike.*—The ordinary form of latch is made with a V-shaped bevel, the long side of the bevel striking against a plate on the door jamb. If the spring on the latch is at all stiff it requires considerable force to push the latch back, besides causing much wear on

the bevel of the latch. To overcome this the anti-friction strike was invented. Fig. 372 shows a form of anti-friction strike used by several manufacturers. The strike is about  $\frac{3}{16}$  of an inch thick and placed at the bottom of the latch (in some makes it is in the middle

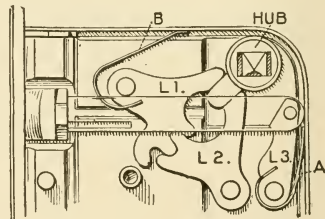

Fig. 371.—Latch of Yale "Vulcan" Lock.



of the latch). The strike is pivoted as shown and a peg on the strike works in a slot in the latch, which carries it back without friction on the sides. The anti-friction strike is not required where there is an easy spring action, although it is a desirable feature on front door locks and those for heavy doors.

The hub is a solid piece of metal (bronze in the better grade of locks) which receives the spindle and turns with it. Two arms or cams are usually cast on the hub, which draw back the carriage as the knob is turned. The hub of the Yale "Vulcan" locks is made of two pieces of forged steel, accurately fitting the flanged bearings of the case. This hub has an oblong opening for the spindle, as shown in Fig. 371, with the larger dimension horizontal, to allow for shrinking or swelling in the door, which is often the cause of the binding of knobs and spindles of the ordinary locks.

*Key.*—The general shape of the key for ordinary tumbler locks is that shown in Fig. 373, the best keys being made of steel and nickel plated. The portion of key marked *A* is called the bow, *B* is the shank and *C* the bit. The notches on the edge of the bit at *E* are made to fit the levers, while notches at *F* show that the keyhole is protected by wards.

For locks with a projection on the edge of the keyhole, the key has a groove in one side of the bit to fit the projection, as shown in Fig. 370.

**216. Wrought Metal Locks.**—Within the past two years ('96 and '97) locks made entirely from wrought materials by machinery and interchangeable in all parts have been placed on the market, which appear to mark a new step in the improvement of the ordinary lock.

At the present time the Yale "Vulcan" locks are, to the best knowledge of the author, the only locks that are made entirely of wrought metal, although the new Warner locks are all of wrought metal except the hub and bolt heads.

In both of these locks the case is pressed from cold-rolled steel, ribbed to give greater strength and stiffness. The posts and guides are riveted to the case, as is also the front.

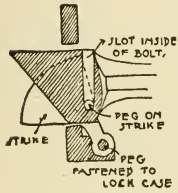

Fig. 372.—Anti-Friction Strike.

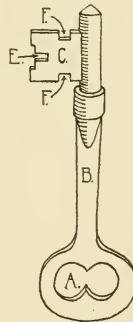

Fig. 373.

In the *Vulcan lock* (made by the Yale and Towne Manufacturing Co.) the front is formed of a base of wrought steel with beveled edges, over which is drawn a cover of wrought bronze, clinched over the edges and fitted so nicely as to appear like one piece of metal. The bolts also are all of wrought metal, the head consisting of a solid piece of wrought bronze or steel with the tail piece forged into it.

The exterior of the *Vulcan lock* is shown in Fig. 397, and the action of the dead and latch bolts in Figs. 369 and 371. The cycloid knob action of this lock is an entirely new principle in lock mechanism. These locks are made with great nicety, so that all the parts fit together perfectly, while the bearings are so broad that there can be but little, if any, wear on the various parts, more especially on the hub. The *Warner locks* are also very nicely made, and although the bearings are not as broad as in the *Vulcan locks*, they are a great advance over the common cast lock.

It is probable that within a few years machine-made locks, entirely of wrought metal, will wholly take the place of the ordinary cast lock, as with the proper machinery a better quality of lock can be made at no greater, and possibly at less expense.

**217. Grades of Locks.**—The value of a lock depends much upon the way in which the parts are planned, and as no two manufacturers use exactly the same arrangement, it is difficult to compare locks of different makes without considering them in detail. Nearly every manufacturer, however, makes different grades\* of locks, which may in general be described as follows :

First and cheapest grade.—Iron face and bolts, steel springs and a steel lever.

Second.—Locks with brass face and bolts, all the rest of iron, one lever.

Third.—Locks with bronze metal front and strike, bronze metal bolts, wrought steel inside works and nickel-plated forged steel key. (This is probably the best grade of one-tumbler locks.)

Fourth.—Same as third, with two, three or four levers. Each grade is usually made in  $3\frac{1}{2}$  and 4-inch sizes for inside knob locks.

As a rule, a 4-inch lock of the fourth grade with three levers is as good a lock as is needed for the inside doors of dwellings. Of course, even in this grade there are differences between the locks of different manufacturers, and between a cast lock and a high grade

\* The term "grade" is here used to designate differences in the materials used, and the number of levers and changes, rather than the quality of the work, as some manufacturers make their cheaper locks equally as well as the better grades.

machine-made lock. A lock that is made with fifty "changes" in the gatings is also to be preferred to one with only twelve or twenty-four changes, as there is less chance of any two keys in the building being alike.

For heavy doors, especially in office buildings, an anti-friction latch may be specified, although this latch does not appear to be as much used as formerly. When greater security than that afforded by a three-lever lock is desired, a "cylinder" lock should be specified.

**218. Varieties of Tumbler Locks.**—Tumbler locks are made of several different styles or patterns to suit different purposes. These are classified as knob latches, knob bolts, dead locks, store door locks, knob lock and latch, three-bolt chamber door lock, communicating door knob latch with thumb bolt, communicating door knob lock, front door and vestibule locks, sliding door locks, master keyed locks and sliding door locks.

Dead locks knob locks and hotel locks are made both rim and

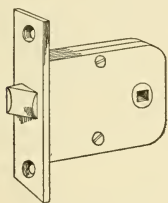

Fig. 374.—Knob Latch.

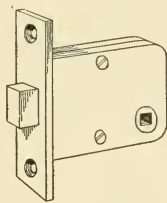

Fig. 375.—Knob Bolt.

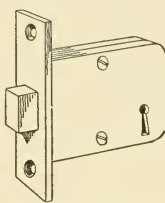

Fig. 376.—Dead Bolt.

mortise, and rim knob locks are also made with thumb bolts, but the other varieties are usually found only in mortise locks.

Front door, store door and the common mortise knob lock and latch may be obtained with either plain or rebated fronts, but the other patterns are made only with plain fronts, except that sliding door locks are made with astragal fronts.

A *rebated* lock is made the same as a plain front lock, except that the front is rebated, as in Fig. 382, to fit the rebated edge of the door. Rebated locks are used only on double doors, and are necessarily made in right and left hands.

*Knob Latch* (Fig. 374.)—This contains only the latch bolt and its accompanying mechanism, operated by knobs and spindle, and is used only where a lock is not desired—occasionally on closet doors.

*Knob Bolt*, Fig. 375, contains a simple dead bolt operated by a thumb knob from the inside of the door. Frequently used on out-

side doors and chamber doors for additional security, as it cannot be picked from the outside. Takes the place of the common surface bolt on account of neater appearance.

*Dead Lock* (Fig. 376.)—This is a simple lock without a latch, and is operated by a key from either side of the door. It is used principally on store doors, double-action doors, and where an additional lock is desired. For store doors a lock with a wide bolt and at least three tumblers should be used.

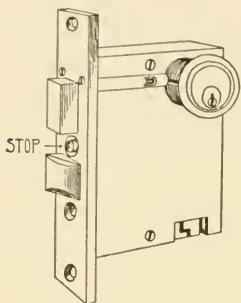

Fig. 377.

*Store Door Locks* (Fig. 377.)—The regular store door lock consists of a case containing a strong dead bolt operated by a key from both sides of the door, and also a latch bolt operated independently by a thumb latch from either side. The thumb latch and handle enables heavy doors to be more easily

swung than by knobs, and the door being usually locked only at night, a spring bolt is not necessary. Store door locks of the better grade are usually fitted with "cylinder escutcheons." The locks are made in several sizes, and may be had with stop work, by setting which the outer thumb latch is dogged so that no one can enter without a key.

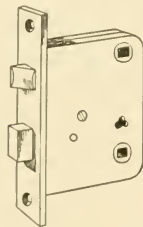

Fig. 378.—Knob Latch with Thumb Bolt.

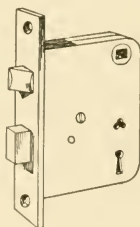

Fig. 379.—Knob Lock and Latch.

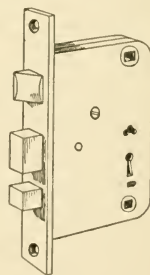

Fig. 380.—Three-Bolt Chamber Door Lock.

while those inside may leave freely. A store door lock with stops is practically a front door lock operated by a thumb latch instead of knobs, and is often used on outside church doors.

The Yale & Towne Manufacturing Co. also make a special store door lock for double-acting doors.

*Knob Lock and Latch* (Figs. 378 and 379).—This is the common form of lock and latch generally used on inside doors, the mechanism of which is described in Sections 214-15. Aside from the quality and mechanism, the variations in this lock consist principally in the size of the case and in the "back set."

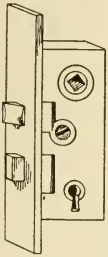

Fig. 381.

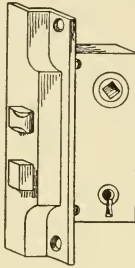

Fig. 382—Rebated Front.

The common sizes are  $3\frac{1}{2}$  and 4 inches or  $3\frac{3}{4}$  and  $4\frac{1}{4}$  inches, according to the make. The larger size should be specified for heavy doors.

The *back set* is the distance from the edge of the door to the centre of the hub. This distance varies in different makes of locks, and each manufacturer makes locks with different back sets to suit different conditions,

the distance being always given with the description of the lock. The more common back set is  $2\frac{3}{4}$  inches, although on  $3\frac{1}{2}$ -inch locks it is often but  $2\frac{3}{4}$  or  $2\frac{1}{2}$  inches. For doors with a narrow stile an upright lock (Fig. 381) may be had, with a back set of only  $1\frac{3}{8}$  inches or even 1 inch. When the back set is less than  $1\frac{3}{8}$  inches, however, a lever handle, such as shown in Fig. 398, should be used. If the stile of the door is very wide, a lock with a back set of 3 inches may be had, which gives greater clearance between the hand and the door jamb. When designing an ornamental door, the back set of the lock and also the size of the knob and escutcheon should be considered, that they may come well on the door and not be too wide for the stile or interfere with any mouldings.

The *Three-Bolt Chamber Door Lock*, Fig. 380, is an ordinary knob lock and latch with an additional bolt below the key bolt, operated from the inside by a thumb knob. This is a very desirable lock for the chamber doors of private residences.

For "*communicating doors*"—i. e., doors between two chambers or

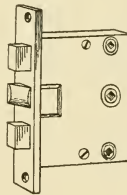

Fig. 383.—Communicating Door Latch.

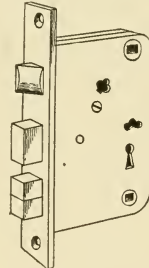

Fig. 384.—Communicating Door Lock.

offices—two styles of locks are used, the simplest (and cheapest) being the communicating door knob latch (Fig. 383), which has a latch bolt and two dead bolts, operated by thumb knobs, one on each side of the door so that the door may be perfectly secured from either side. This lock may also be used for water closet doors between rooms. The other style is the communicating door lock (Fig. 384), which is a knob lock and latch with the addition of two dead bolts operated one from each side of the door. The advantage of this lock over the latch is that the door may be locked with a key so that the occupants of the two rooms cannot communicate with each other without picking the lock. It is particularly adapted to communicating doors of hotels and lodging houses.

The Russell & Erwin Manufacturing Co. make a mortise knob lock with two key bolts, operated from disconnected key holes, so that when locked from one side it cannot be unlocked from the other. This differs from the lock shown in Fig. 383 only by the bolts being operated by a key instead of a thumb piece, which might be an advantage in some cases.

**220. Front Door and Vestibule Locks.**—The usual tumbler lock for front doors differs from the ordinary lock and latch in having a swivel spindle so that the knobs may be turned independently of each other, and a stop mechanism by which the outer knob may be set, so that the latch can be operated from the outside only by a key, while it is readily drawn by the knob on the inside. The dead bolt is operated by a key from both sides as with inside locks. There are thus two keyholes on the outside and one on the inside of the door. The latch and bolt keys are usually different. The Yale Standard front door lock is made so that both the latch and bolt may be operated by a single key.

The cheapest grade of front door locks do not have the swivel spindle, and when the latch is set it can be operated from the inside only by a thumb piece. Such locks are hardly suitable for good residences.

*Vestibule doors* of residences should be fitted with a “vestibule latch” made to match the front door lock and operated, when the outer knob is set, by the same latch key, the latch being similar to the front door lock, but with the dead bolt omitted.

The front and vestibule doors of nearly all first-class residences are now usually trimmed with “cylinder escutcheon” locks, with which one small key operates both the latch and dead bolt of the front door and the latch of the vestibule door.

Fig. 385 shows the general appearance of the Yale Paracentric front door lock and its corresponding vestibule latch; the Yale Standard (tumbler) lock differing only in the locking mechanism.

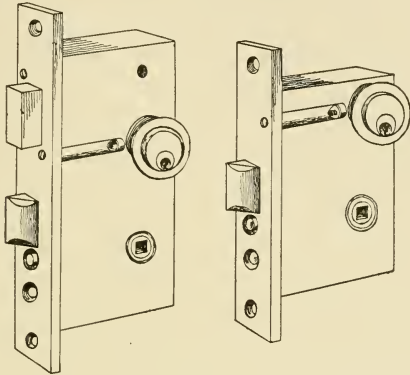

Fig. 385 — Yale Front Door Lock and Vestibule Latch.

*Sliding Door Locks and Pulls.*—The common form of sliding door lock is that shown in Fig. 386, the curved bolt being operated by a key from both sides. The flush pull is pushed into the case when

the door is closed, or may be pushed in by the hand, and is thrown out by pushing in the button *B*. The locking mechanism is usually quite simple, as for sliding doors in residences great security is not often required.

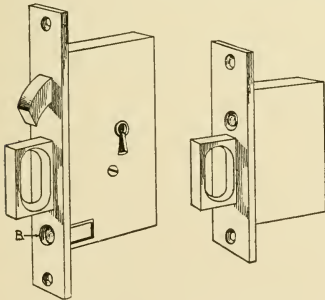

Fig. 386 — Sliding Door Lock.

Fig. 387.—Sliding Door Pull.

The Yale & Towne Manufacturing Co., and possibly others, make a form of sliding door lock and also a sliding door night latch, that offers as much security as any lock.

They also make a lock for communicating sliding doors, with bolts operated by thumb pieces. Sliding door locks for double doors are made with both straight and astragal fronts.

Locks for sliding doors are also made with an easy spring latch bolt operated by knobs and locked by a key. Knobs, however, cannot ordinarily be used on sliding doors, as they would strike against the frame, the ordinary trim for sliding doors being the cup escutcheon shown in plate, and an extension or jointed key is used that will not project beyond the face of the door.

If a lock bolt is not deemed necessary, a simple flush pull (Fig. 387) with blank escutcheon plates may be used.

**221. Master Keyed Locks.**—In office buildings, hotels and lodging houses, it is desirable that the person in charge shall be able to enter any room when not occupied by means of a single key that will operate all of the locks, while the regular keys shall not be interchangeable. Locks made on this principle are termed "master-keyed locks," the master key operating all of the locks in the set, while the "change key" will only operate the lock for which it is made.

All of the better grades of mortise knob tumbler locks can be had master keyed, at a slight advance in price, and most cylinder escutcheon locks can be had master keyed. The method adopted for master keying differs with different makes and grades of locks. In the cheaper grades master keying is accomplished by merely introducing different wards or obstructions either in the keyhole or in the path of the key, and making a skeleton key that will pass these obstructions. Such locks offer little security. Another method has been to have different keyholes for the master key and change key.

The best grades of tumbler locks are master keyed by means of auxiliary tumblers, which, when raised to the proper height by the master key, also set the remainder of the tumblers and enable the bolt to be shot, while the change key does not act on these auxiliary levers and must be bitted for each lock to correspond with the combination of levers, and hence will not interchange. Each lock, therefore, has all the security of an ordinary three-lever lock. Such locks, however, require careful adjustment and excellent workmanship, and are therefore somewhat expensive. Master keyed tumbler locks are made in sets of from 200 to 300, and by using different sets with different master keys, as many as 4,000 changes may be had.

Cylinder escutcheons may also be master keyed in sets and with a grand master key.

The system of master keying offering the greatest security, in the opinion of the author, is the Yale duplex master key system, which consists in every instance of *two* Yale escutcheons acting upon one and the same bolt. This gives two keyholes to each lock, the lower ones for the master key being set to the same combination through-



out the suite, while the upper ones are all different. By this system all of the security of the Yale lock is retained, while a single master key can be made to pass a series of locks of an almost indefinite number of changes.

*Hotel Locks.*—The especial requirements of hotel locks are that they shall be master-keyed and so arranged that while they may be secured from the inside the occupant cannot possibly be locked in. The best hotel tumbler locks have three bolts, a latch bolt operated both sides by knobs, a key bolt operated from *outside only* by both the "change" or room key, and the master key and a dead bolt operated from the inside by a thumb piece. The dead bolt cannot possibly be operated from without, and when the door is locked from within a curtain is thrown over the outer keyhole so that the key cannot be inserted.

For the cheaper class of hotels a common three-bolt chamber lock, master keyed, or a common knob lock and latch, master keyed and locked from the inside by the change key only, are commonly used.

**222. Cylinder Locks.**—This term is now quite generally used to designate those locks in which the bolt or latch, or both, are operated by means of a cylinder escutcheon, which is really separate from the lock proper. The first cylinder lock or escutcheon was invented by Linus Yale about the year 1860, and for a number of years the "Yale" lock was the only cylinder lock on the market. The great success of this lock has led to the adoption of somewhat similar escutcheons by other lock manufacturers, so that there are now four or five cylinder locks in common use.

The original Yale lock had a small flat key and a small narrow slit for the keyhole. About the year 1880 a corrugated key and keyhole was introduced which further increased the security of the lock and the possible number of changes. This has in turn been superseded by the Yale Paracentric escutcheon, which represents the highest development in key locks.

The construction and operation of this escutcheon, and also the general principle of cylinder escutcheons, are shown by the illustrations Figs. 388 and 389.

It will be seen that there are two barrels or cylinders, one rotating within the other, but eccentric with it. The lower cylinder is held from rotating by five sets of round pins, each set consisting of two pieces as shown in the section. When the key is drawn the pins are forced down into the lower cylinder so that it cannot be turned, but when the proper key is inserted in the lock all the pins are raised so

that the joint in each set will just come on a line with the top of the lower cylinder, and the cylinder can then be rotated. A cam on the back of the rotating cylinder works the bolt in the lock.

It is evident that as the inner cylinder is exactly fitted to the bore in the shell, an almost imperceptible variation in the height to which any one of the pins is raised will prevent the plug from turning, whence it follows that an immense number of locks can be made with such mechanism without duplication.



Fig. 388.

This arrangement of cylinders and pins is identical with that of the original Yale lock, the later improvements being in the shape of the key and keyhole. In the original Yale lock the keyhole was a narrow vertical slot, and it was possible for an

expert lock-picker to open the lock by tilting a key or pieces of wire up and down in the keyhole until the pins were brought to the proper position for opening. To prevent this the corrugated key and keyhole was devised, and the new paracentric escutcheon is so constructed that it is impossible to insert any but the proper key in

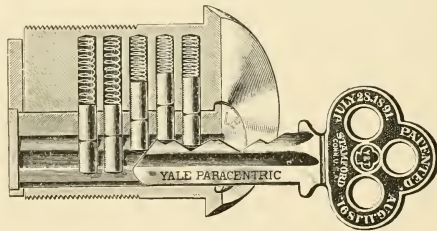

Fig. 389.

the keyhole or to use any picking instrument to operate the tumblers vertically, the shape of the keyhole shown on the face, Fig. 388, being continuous throughout the length of the lock.

An incidental advantage resulting from this change in the keyhole is that as it differs absolutely from every predecessor, no key heretofore made can enter one of these locks. The paracentric key is also a very difficult one to make, and the blanks can only be obtained from the manufacturers, hence the difficulty in duplicating a key.

As before stated, there are several other kinds of cylinder locks, a few of which somewhat resemble the old style Yale lock with corrugated keyhole. All of these locks offer greater security against picking or accidental interchange of keys than tumbler locks, and they are therefore considered as the best lock for front doors, office and store doors, drawers, lockers, and wherever special security is desired. A secondary advantage possessed by these locks, is the smallness and convenient size of the key.

**223. Office Locks.**—It is generally desirable that the outer door of offices shall be fitted with a cylinder escutcheon lock. The most convenient lock for an office door is believed to be a cylinder latch with stop work similar to the vestibule latch, Fig. 385, as it is of great convenience in enabling the door to be made fast when leaving, without being obliged to stop and use a key. To prevent any instrument

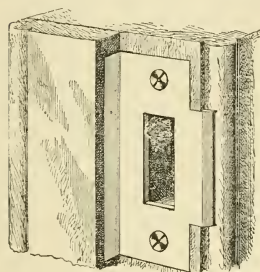

Fig. 390.—Yale Protected Strike.

from being forced through the wooden stop of the door jamb to the beveled edge of the bolt, and thus forcing it back, the Yale protected strike (Fig. 390) has been introduced, which gives to the latch all the security of a dead bolt. This strike is applicable to all latch bolts, but must be made to order to correspond to the exact thickness of the door. The Russell & Erwin Manufacturing Co. make a special office door latch with a supplemental bolt which automatically locks the main latch when the door is closed, so that it cannot possibly be forced back. In important office buildings all of the office doors are master keyed.

Another arrangement for office doors which is preferred by some, consists in using a good three-tumbler lock and putting on a supplemental cylinder rim night latch, which may be changed or a new cylinder obtained with a change of tenant. The advantage of this lies in the fact that duplicate keys are often given out, some of which may be lost or may not be returned when the office is vacated, and thus some unknown person may have access to the office. By changing the lock such possibility is avoided. If a single mortise cylinder latch is used, however, the same result may be obtained by purchasing a new cylinder, as the cylinders of each manufacturer are interchangeable.

**224. Night Latches.**—These consist of a latch operated from the outside by a key, and from the inside by a thumb knob or slide. A stop is always provided for holding back the latch when desired. They are made both rim and mortise, but the rim locks are generally used for the reason that they do not weaken the door and are more easily applied.

Night latches are very extensively used on office doors, club house doors and the rear outside doors of residences. They are always used in addition to an ordinary knob lock and latch. As they are used principally to give greater security, it is hardly worth while to put on a tumbler lock, hence nearly all the night latches now used have cylinder escutcheons. For ordinary purposes rim night latches are finished in black japan, but bronze metal cases are made for rooms where an ornamental finish is desired. The better grade of rim locks have the striking plates and front plate of lock extended so that they may be screwed to the jamb and edge of the door, thus necessitating breaking of the woodwork to force the door. The Yale & Towne Manufacturing Co. have recently introduced an oxidized copper rim lock which is made so that no screws are exposed when the door is closed, the case being attached to the door by an interlocking back plate screwed to the door and by two screws in the edge of the door. Rim night latches may be used on either right or left hand doors, but if the door opens outward a reverse bevel is required.

**225. Door Knobs and Escutcheons.**—Until within a comparatively few years the trimmings commonly used with mortise locks consisted of a pair of knobs, roses and escutcheons.

The rose was a round metal plate made to be screwed to the door and with a socket to receive the shank of the knob and prevent its wearing out the lock; it also made a finish over the hole in the door. The escutcheon was a small plate with a keyhole, Fig. 392, used to make a finish over the keyhole in the door. On outside doors they were often provided with a cover which dropped over the hole. Rim locks are often trimmed in the same way on the outside of the door, but on the inside no rose or escutcheon is needed. These trimmings are still used to a considerable extent in very cheap work, and also in very nice work, where a special effect is desired, but as a general thing the rose and escutcheon are now combined in one long plate, termed "escutcheon plate" or "combined escutcheon," for the reason that a long plate can be more securely fastened to the door, because the screw holes are placed above and below the lock, while

with the rose and small escutcheon one of the screws, and sometimes both, come opposite the lock case where there is but little wood to receive them. For ordinary trimmings the long escutcheon also has the neatest appearance and the difference in cost is but very slight.

As the term "escutcheon" is used to designate both the small keyhole plate and the long plate for knob and keyhole (and also the key mechanism of cylinder locks), it is not at all definite when used alone, hence in specifying, either the "combined rose and escutcheon,"

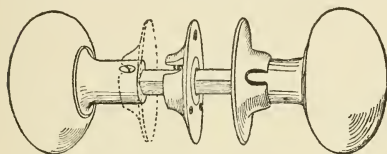

Fig. 391.—Knob With Spindle—Screw Partly Covered.

or the particular catalogue number desired should be given.

The Yale & Towne Manufacturing Company have adopted the term "key plate" to designate the old style escutcheon, and they make several ornamental patterns with and without covers for the keyhole, for use with glass knobs. The shape of the escutcheon does not as a rule effect the knobs and spindle, *i. e.* on plain goods.

The Yale & Towne Manufacturing Company have adopted the term "key plate" to designate the old style

*Knobs and Spindle.*—The common knob, spindle and rose is shown in Fig. 391. The knobs themselves are made of various materials and in different shapes, but all are fitted to a metal shank which receives the spindle. The spindle is the square iron bar which connects the knobs and transmits the knob motion to the hub of the lock or catch. The common method of attaching the shank to the spindle is by means of a screw (see Fig. 391) which passes entirely through the spindle. There are generally three screw holes in each end of the spindle to permit adjusting to

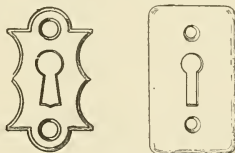

Fig. 392.

doors of different thickness. It is generally impossible, however, to adjust the knob shanks perfectly by screws alone, and hence small washers are depended upon for the closer adjustment between the end of the shank and the socket of the rose or escutcheon plate. The difficulty of getting a perfect adjustment of the knobs so that they will not rattle, and the tendency of the screws to work loose and drop out, have led to the invention of a number of devices for attaching the shank to the spindle without the use of screws passing through the spindle. Although many of these devices are ingenious

and possess much merit, but two or three are now used to any extent, and the common square spindle with a screw is much more extensively used than any other pattern. The Yale & Towne Manufacturing Co., are the only manufacturers, the author believes, that exclusively use a patent spindle. The Triplex spindle used by them consists of three triangular rods which, when united, form a square spindle to one end of which one knob is permanently pinned.



Fig. 393 - Swivel Spindle.

The other knob carries a set screw which bears on the spindle as shown in Fig. 394. The tightening of this screw forces the spindle into frictional engagement with the knob shank and holds the knob securely at any point, thus affording perfect adjustment without resort to washers, and eliminating all looseness and rattle of the knobs. Messrs. P. & F. Corbin and the Russell & Erwin Manufacturing Co. make screwless attachments for use with their cast bronze knobs, which accomplish practically the same result as the triplex spindle, although at slightly greater expense.

Front door and vestibule locks, in which the knobs turn independently of each other, are usually fitted with a swivel spindle, as shown in Fig. 393. With such locks the outer knob should be fixed to the spindle without screws, otherwise the shank can be removed from the outside of the door, the spindle pushed in and the inner latch follow turned back.

**226. Shape and Material of Door Knobs.**—The shape of a door knob depends somewhat upon the material of which it is made and whether it is a wrought or cast knob.

For mineral and cast metal knobs the more common shape is that of a flattened sphere, as shown in Fig. 394. Cast bronze knobs and Bower-Barffed iron knobs are also made ball shape, which usually adds a little more to the cost. Cast bronze metal knobs are also made egg shaped and in the form of a letter S.

Wrought bronze metal knobs are commonly made of the two general shapes shown in section, in Fig. 395. These knobs are known

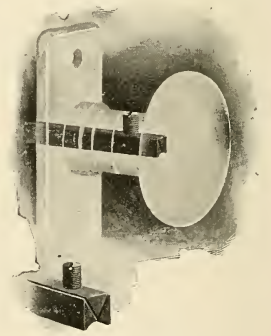

Fig. 394.—Yale Triplex Spindle.

to the trade as "spun knobs," they are made of two pieces of metal, shrunk together, and to the shank, as shown. Spun knobs are less expensive than cast knobs, and cannot be made without a bead or edge where the parts are joined, the bead on the edge of a knob being generally indicative of wrought metal, although some cast knobs have a lead on the edge, and many of the best wrought knobs are made in the shape shown in Fig. 394, the bronze being worked over a wrought steel shell. The common sizes of round knobs, whether flattened or spherical, are  $2\frac{1}{4}$  inches for inside knobs and  $2\frac{1}{2}$  inches for outside knobs.

*Material.*—The cheapest knobs are made of earthenware, porcelain and various compositions, and are commonly known as "mineral knobs" when of a mottled color, "jet knobs" when black and "porcelain knobs" when white. All of these knobs are sold with iron or bronze shanks and roses. The bronze is much the better, both in appearance and durability, and should always be specified (with these knobs) for everything but the most inferior work.

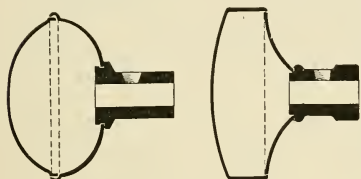

Fig. 395.

A good jet knob with bronze shank and wrought bronze escutcheon plate makes a neat trimming for cottages and the inferior parts of larger houses. It

is easily kept clean and does not change in color.

Wooden knobs, finished in the natural color, have been used to some extent, and may be obtained in most large cities. Their shape is usually that of a flat disc.

Glass knobs were at one time very popular, but owing to the difficulty of applying them and the fact that they were made hardly good enough for the best work and were too expensive for ordinary rooms, their use became extremely limited.

The Yale & Towne Manufacturing Co., however, have recently placed on the market a line of cut glass knobs which are free from all of the objections made to the old style knobs, and besides being very handsome, harmonize admirably with many schemes for interior decoration. These knobs have bronze shanks fitted to the triplex spindle, and are commonly trimmed with round roses and small key plates, although escutcheon plates may be used if desired. A few patterns of these knobs are illustrated in Plate V. They are made

of three general types, as follows: A plain round knob of flat form, a plain octagon form, a plain spherical or ball form—each type being cut in various ornamental patterns.

The more common material for door knobs at the present time is bronze metal, either wrought or cast, this material being susceptible of a great variety of shapes and finishes and of a very high grade of ornamentation. The principal finishes used are described in Section 203. Where the knobs are subject to much wear, a plain round cast knob, natural finish, generally gives the best satisfaction, as it is easy to the hand and is easily kept bright. Nearly all of the plated finishes

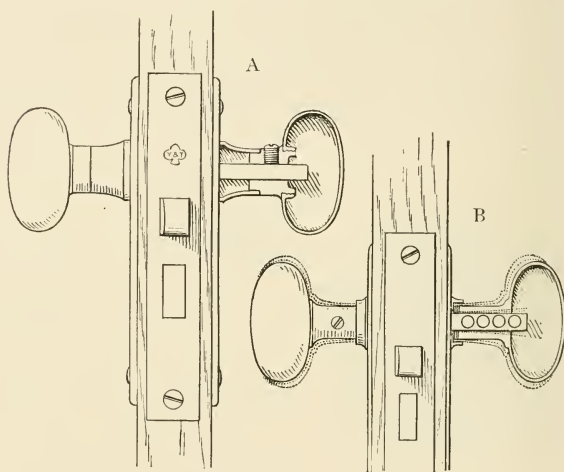

Fig. 396.

show the effects of wear after a time, although the ornamental goods may be used for a long time in residences without any perceptible change.

Iron knobs, finished by the Bower-Barff process are much used for public buildings.

**227. Escutcheon Plates.**—These are now made almost entirely of either wrought or cast bronze, plain, and in the various ornamental finishes. They vary in size from  $5\frac{1}{2} \times 1\frac{1}{2}$  to  $7\frac{1}{2} \times 2\frac{1}{4}$  inches for inside doors, and almost indefinitely for outside doors. When ornamented they are usually made in sets to match the ornamentation of the knob.



The plain escutcheons for  $3\frac{1}{2}$  or 4-inch locks are usually interchangeable for the same size of lock, and may be used with jet or porcelain knobs or any plain knob, although it is generally necessary to use a knob made by the same manufacturer, and different makes of locks and escutcheons are not usually interchangeable. The same escutcheon will not usually fit a  $3\frac{1}{2}$ -inch and a 4-inch lock on account of the position of the keyhole.

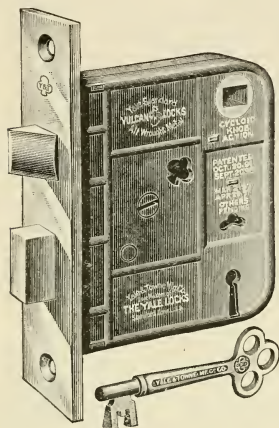

Fig. 397.—Vulcan Wrought Metal Lock.

Outside escutcheon plates for tumbler locks are usually made with covers for the keyhole, as in Plate I. Various shapes of ornamental escutcheons are shown in Plates I to IV.

Aside from the shape and ornamentation, there is an important difference in escutcheon plates in the bearing which they afford for the knob shank.

The common type of escutcheon plate has a very shallow socket for the shank of the knob to fit into, which brings the bearing near the surface of the door and permits of a slight tilting motion, as shown by the knobs at *B*, Fig. 396. The escutcheon plates, made by the Yale & Towne Manufacturing Co., have a long bracket bearing, as shown in the section at *A*, which supports the knob near the end of the spindle, and prevents the tilting motion.

**228. Hardware in Sets.**—Mortise locks with their trimmings are now largely sold in "sets," a set for a knob lock, consisting of one lock, a pair of knobs and two escutcheons, and corresponding sets are made for front doors, sliding doors, communicating doors, etc. The sets are also made up for different grades of locks and for different styles and grades of trimmings. The convenience of this arrangement lies in being able to specify both the lock and its trimmings by one number. In selecting goods in sets, however, the architect should carefully read the descrip-

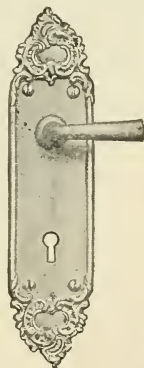

Fig. 398.  
Lever, Handle and  
Escutcheon.

tion of the lock or examine the lock itself as cheap locks are often put up with very attractive trimmings.

**229. Ornamental Trimmings.**—Within the past ten years the efforts of the leading manufacturers of builders hardware appear to



Fig. 399.—Latch and Handle.

Some very pretty hardware is also made of wrought metal by the "*repoussé*" process. This line is much cheaper than the cast hardware, and lacks the delicacy of the latter, but may be used with good effect in cottages and moderate priced residences.

The various ornamentations are grouped by the manufacturer

have been devoted principally to the production of artistic designs for the hardware trimmings of doors and windows, with the result that one can now readily obtain trimmings of high artistic value and of almost any school of ornament. In fact, the scope of the designs published by the leading manufacturers is so broad and varied as to meet almost every requirement of individual taste or preference while avoiding the commonplaceness resulting from a restricted line or inferior designs.

The more highly ornamented patterns are made of cast brass or bronze, plated with gold, silver or copper or left with a natural sand finish. Many very ornamental patterns are also made in cast iron, treated by the Power-Barff, or a corresponding process.



Fig. 400.  
Cremorne  
Bolt.

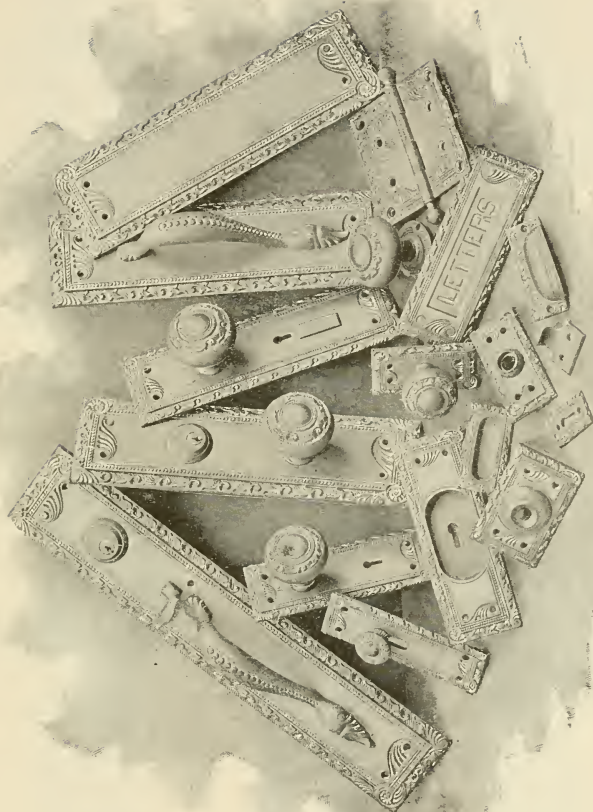

Group of Door and Window Trimmings—D Design.  
Sargent & Co., Manufacturers.

PLATE I.



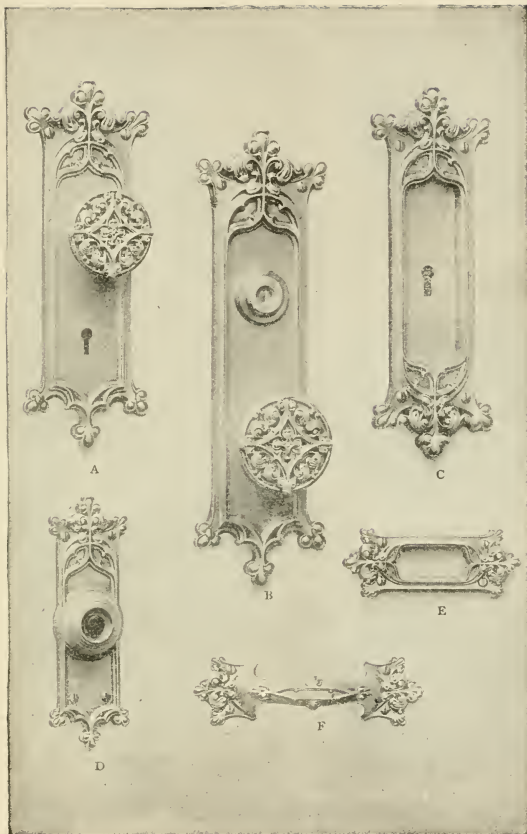

Ornamental Hardware.—Gothic Design.

Russell & Erwin Manufacturing Co.

- |  |                            |
|--|----------------------------|
| <i>A.</i> Inside Knob and Escutcheon.  | <i>D.</i> Push Button.     |
| <i>B.</i> Outside Knob and Escutcheon. | <i>E.</i> Flush Sash Lift. |
| <i>C.</i> Sliding Door Escutcheon.     | <i>F.</i> Bar Sash Lift.   |

PLATE III.





Ornamental Rim Lock.



Flat Round Knob.

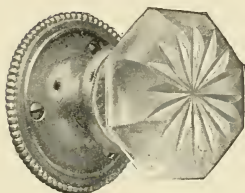

Octagon Knob.

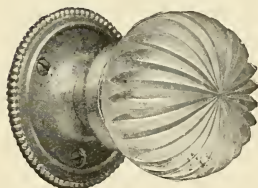

Ball Knob.  
Cut Glass Knobs.

Made by the Yale & Towne Manufacturing Co.

PLATE IV.





under an appropriate name or designated by letters, and each design usually includes the following trimmings: Front door knob, inside door knob, round or oval, escutcheon plates for front and vestibule doors, inside doors, communicating doors, chamber doors with thumb

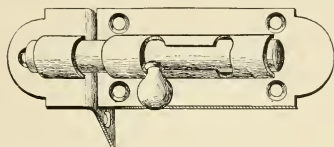

Fig. 401.—Barrel Bolt, Bent Staple.

bolt, cup escutcheons for sliding doors, push plates, push buttons, door pulls, sash lifts, mortise flush bolts. Many sets also include store door handles and escutcheons, lever handles, drawer pulls, shutter knobs, door knocker, letter box plate

and hinge plates, so that all of the hardware throughout the building, with the exception of the butts and locks, may have the same ornamentation. Lock fronts, butts and transom bars are usually left with a plain surface, finished to correspond with the finish of the trimmings, although butts of same the design can be obtained from

some manufacturers. To give an adequate idea of the extent and artistic quality of the product of the different hardware manufacturers in a work of this character would be impracticable, even if desirable.

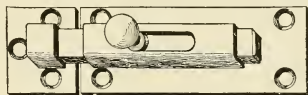

Fig. 401a.—Light Square Bolt.

The illustrations on pages 375-378 however, serve to show somewhat the character and artistic quality of the leading lines of such goods in the market. Plate I also serves to illustrate the various pieces included in each ornamentation.

In Plate II, an attempt has been made to give some idea of the relative cost of the different designs shown, the figures under each cut giving the relative price as compared with the plain bronze knob and escutcheon as a base.

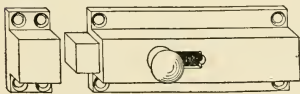
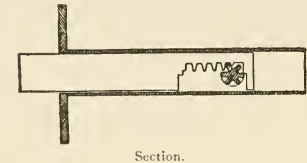

Fig. 402.—Square Case Bolt.

In Plate IV is shown a suggestion for the artistic treatment of a rim lock. On thin doors, cupboard and cabinet doors, rim locks possess advantages over mortise locks, and there is no reason why they should not be more extensively used than at present, unless it be the difficulty of obtaining them in ornamental patterns.

**230. Door Bolts.**—The greatest security against a door being opened from the outside, is undoubtedly obtained by means of bolts operated only from the inside of the door.

The simplest bolts are those which are made to screw to the inside of the door, and of these the most common is the barrel bolt, Fig. 401. The common barrel bolt, however, has a plain flat staple plate, and if a staple plate like that shown in the illustration (which is



Section.

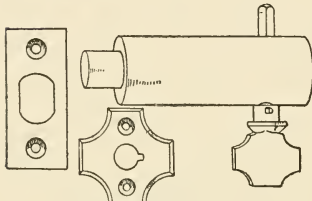

Fig. 403 Gem Bolt.

obviously much stronger) is desired, a "bent staple plate" should be specified. When made of wrought steel, the bolt shown in Fig. 401 is believed to be the strongest bolt made. Fig. 401*a* shows a light square bolt, and Fig. 402, a "square case" bolt, which differs from the square bolt in not having as long a slide, and the end of the case is closed. Square bolts of these patterns are not usually over 4 inches long, while barrel bolts are made 3, 4, 5, 6 and 8 inches long. Small barrel and square case bolts may be obtained in

solid bronze. Cast iron bolts are not very reliable, as being brittle, the bolt or case may be broken.

Bolts of the above description, however, do not have a very neat appearance in nicely finished rooms, and hence in such places mor-

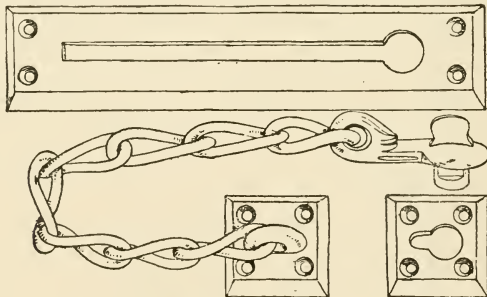

Fig. 404.—Chain Bolt.

tised bolts are preferred. The neatest mortise bolt is probably the knob bolt shown in Fig. 375, or an extra bolt in the lock, as in the three-bolt chamber door lock.

When the door is already fitted with a common knob lock, a cylinder mortise bolt, of which the well-known Gem bolt, Fig. 403, is one of the best examples, may be used to advantage. This bolt is very simple in its mechanism, as shown by the section drawing, and when fully thrown the bolt cannot be pushed back.

*Chain Bolts.*—These are sometimes used on front doors of dwellings; they permit the door to be opened a few inches to see who is at the door, while preventing it from being further opened.

Fig. 404 illustrates the typical chain bolt, which consists of a slotted plate to go on the face of the door, and a chain secured to the door jamb with a dog on the end of the chain which will slide freely in the slot of the plate. A holder is provided to which the chain can be attached when not in use. There are many varieties of these fasteners, all based on the same principle. They are generally of brass or bronze, finished to correspond with the rest of the trimmings.

**231. Bolts for Double Doors.**—When doors are hung in pairs it is necessary to secure one of the doors to the frame by means of bolts, and the other door is locked to it. The common method of securing the “standing leaf” is by means of bolts placed at the top and bottom of the door. Wherever a neat finish is desired, “flush” bolts are generally used which are either let into the edge of the door or into the inside face of the meeting stile. When the bolt is placed on the edge of the door it is, of course, inaccessible when the other door is closed and locked, hence the doors cannot be opened without the key. When placed on the face of the door, the doors may be opened from the inside by drawing the bolts and pulling both doors open: usually, however, it is not necessary to secure the door from being opened from within.

When the bolt is placed on the edge of the door, the bolt is usually operated by a flush thumb piece, sliding in a sunk slot in the face of the plate, and much trouble and vexation has been experienced with such bolts from the fact that the thumb piece is usually too small to afford adequate means of pushing or pulling them. This has been overcome by the lever device, shown in Fig. 405, which, while still flush with the plate, affords a good hold for operating the bolt, and by its long lever arm enables the bolt to be moved easily under any circumstances. This device is used on the Yale & Towne, and Russell & Erwin bolts, both flush and extension.

When a flush bolt is used on the face of the door it should have either a good sized knob, as in Figs. 406 and 407, or the lever device, shown in Fig. 405. The bolt shown in Fig. 406 is made by

the Stanley Works, and differs from the ordinary flush bolt in having a hooked plate, which adds both to the strength of the bolt and of the door.

Flush bolts are not usually made over 16 inches long, and when the door is over 7 feet high, it is much better to use an extension flush bolt, of which one form is shown in Fig. 407. The extension bolt differs from the flush mortise bolt, in that the bolt with its connecting rod is set in a hole bored in the thickness of the door, and

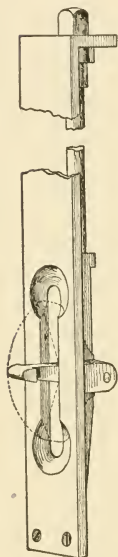

Fig. 405.

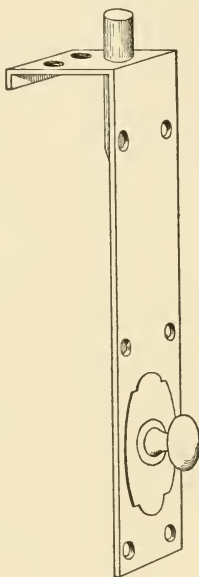

Fig. 406

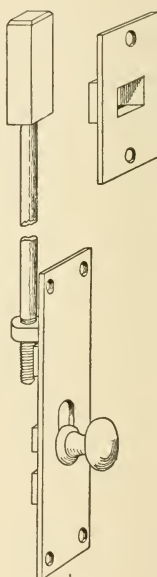

Fig 407.

the plate in which the knob or thumb piece slides is only about 6 inches long. The short plate looks much better than a very long plate and does not weaken the door as much by cutting away. Extension bolts are made with rods varying from 12 inches to 6 feet in length, and may be used either on the face or edge of the door. When used on the face of the door they are often provided with T-handles. The lengths of both flush bolts and extension bolts are

measured from the centre of the slide or lever to the end of the bolt. As a rule 10 or 12-inch bolts are placed in the bottom of the door, and the thumb piece or knob for the upper bolt should be about 5½ feet from the floor, no matter what the height of the door may be; the difference in the length of the rod adds but little to the cost.

Nearly all forms of flush bolts are provided with a spring which prevents the bolt from dropping when shot.

The face plate of both flush bolts and extension bolts may usually be obtained to match the finish of the knobs and escutcheons, and occasionally the ornamentation. The Stanley bolts are all made of wrought steel, planished or polished and plated; most of the other leading manufacturers make their best bolts with bronze metal plates and knobs.

For *store doors* it is customary to use large square bolts screwed to the inside face of the door, the upper bolt ("chain bolt") being a spring bolt provided with a chain to pull it down. The lower bolt ("foot bolt") is made so that the bolt can be pushed down with the foot, while a spring keeps it from dropping when raised. Store door bolts should be either of wrought steel or bronze metal. Cast iron bolts are not desirable, for the reason previously stated.

A special form of flush bolt, known as a "Flush Dutch Door Bolt," is made for connecting the two portions of a "Dutch door" (see Section 164.)

**232. Transom Fixtures.**—Transoms over doors or windows may be hung either at the top or bottom by common hinges, or pivoted in the centre horizontally. If the transom is to be hinged it is generally best to put the hinges at the bottom of the sash, especially over outside doors or windows, as better protection is afforded against wind and rain, and there is less trouble from draughts. It is also more trouble to enter through a transom hung at the bottom. There is an objection to hanging large transoms at the bottom, however, in that should the fixture which holds the transom open, give way, the transom will swing down against the door and very likely break the glass by the fall. Large outside transoms should therefore be centre hung (pivoted) with the bottom swinging out. It is, however, more difficult to screen a pivoted transom than one hinged at top or bottom. Transoms over inside doors are more easily operated when pivoted or hinged at the top.

For hanging the transom at top or bottom, 2 or 2½-inch "narrow butts" (Fig. 408) are commonly used. They may also be obtained with ball tips, as in Fig. 409, but should have a fast joint.

When pivoted at the centre of the ends, sash centres such as are shown in Fig. 410, make as good a pivot as any for transoms of ordinary size, and the common spring window bolt, Fig. 411, also answers the purpose very well where an especially fine appearance is not necessary. There are also two or three patterns of surface sash centres. In private residences it is well to pivot inside transoms so that they can be readily removed without using a screw driver.

Small pivoted transoms require only a catch at the top (one with

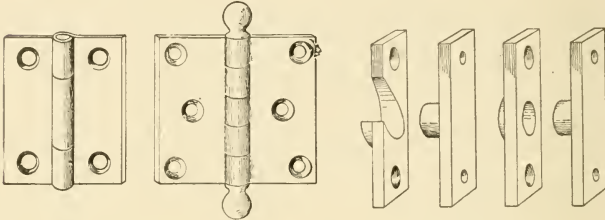

Fig. 408.

Fig. 409.

Fig. 410.—Sash Centres.

a ring pull is most convenient) to fasten them when closed, as no special fixture is required to control them when open. Large transoms, and pivoted transoms over outside doors should be fitted either with a "transom lifter" or the sash adjuster, shown in Fig. 436.

Transoms hung at the bottom are sometimes provided with a transom catch, which can be opened by a cord or pole, and with chains attached to the frame or sash which permit the transom to open only a certain distance. This arrangement, however, is not very satisfac-

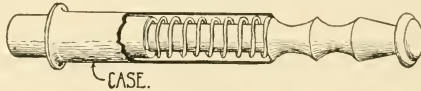

Fig. 411.—Spring Window Bolt.

tory, and it is much better to use a transom lifter of the type shown in Fig. 412. There are several transom lifts of this general type, differing from each other principally in the manner of locking or holding the rod and in the details of their joints. They may be used for transoms hung top or bottom or pivoted, and may be placed at either side of the door. About the neatest transom lifter that the author has seen, is the Yale, which has two steel grip plates which are forced against the rod by strong spiral springs and are released by turning a neat thumb knob. A superior transom lifter is also made by

the Payson Manufacturing Co. Common transom lifters are made with wrought iron rods and cast iron brackets and fittings, and are finished only with bronze paint. The better kinds, however, can be had either in bronzed steel or iron; bronze plated in various finishes on steel; Bower-Barff; or in solid bronze or brass to match any style of finish. The stock lengths are 3, 4, 5 and 6 feet, but they can be made up to 9 feet in length if so ordered. For lifters 5 feet long or over, the rod should be  $\frac{3}{8}$  inch in diameter.

**233. Screen Door Trimmings.**—Screen doors to be effective, must be provided with a spring to close them quickly when open. This spring may be either in the hinge or separate from it. Where a screen door will be in almost constant use, it is probably best to use a good quality of single action spring hinge (with a strong and elastic spring coil), with a simple pull handle for opening the door and a hook or bolt for securing from the inside.

A great many special spring hinges are made

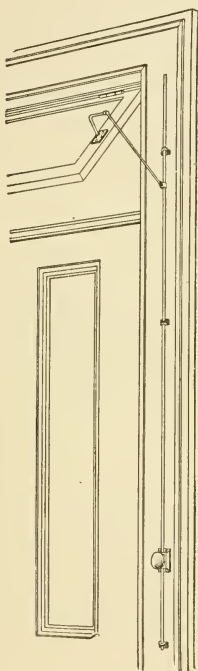

Fig. 412.—Transom Lifter.

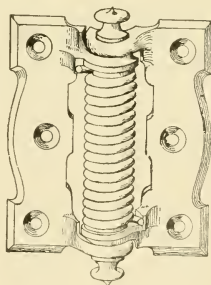

Fig. 413.—Columbia Spring Hinge.

for screen doors, most of which have the spring coil exposed, as in Fig. 413. Most of these hinges are made of cast iron, although a few are made of solid bronze or cast brass with brass springs; the latter makes a very serviceable hinge, although for the best residences, stores and offices the "Bommer," "Oxford" or "Gem" hinges in bronze or brass, are to be preferred. When exposed to the weather, steel hinges are apt to rust.

Many of the cheap spring hinges for screen doors are made so that when the door is revolved about 135 degrees the spring holds the door open instead of closing it. Such hinges are termed "hold-back," and while they are sometimes serviceable, they are not usually as good a hinge for closing the door as the type shown in Fig. 413.

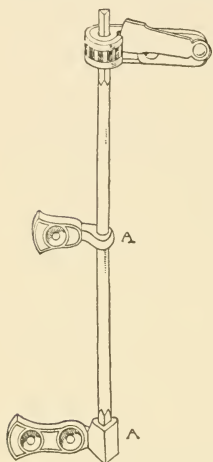

Fig. 414.—Torrey Door Spring.

On residences it is often more convenient to use a pair of plain butts, either 3x3-inch, or 3½x3½-inch, with the spring separate. The spring can then be detached, or the tension released at will.

For separate springs the "Torrey," Fig. 414, is very extensively used, and works very satisfactorily. The tension is adjusted or released by means of the cogs and catch at the top, a small wrench being furnished with the spring for turning the rod.

The "Perfect" door spring, Fig. 415, which is a strong steel spring coil about 17 inches long with a hook at each end, also makes a very good spring for screen doors, as it works nicely and can be very quickly detached. It is secured to the inside of the door at the top, and to the underside of top jamb near the side, by means of screw-

eyes. For the screen doors of residences a catch with stop work and a knob on outside and lever handle on inside, makes the most suitable trimming. Such catches are made especially for screen doors, as a reverse bevel is always required. One of the best catches that the author has seen, is the "Willer," Fig. 416, and a very similar flush catch used by the E. T. Burrowes Co., on their screen doors. The screen door catches usually found in hardware stores are very cheap affairs.



Fig. 415.—Perfect Coil Spring.

**234. Water Closet Doors.**—Where several water closets are placed in a large toilet room, each closet should be enclosed by thin partitions about 3 feet apart, and from 6 to 7 feet high, with a short door placed in front of the closet. These doors are usually hung with spring hinges, either set to close the door or hold it open as de-



sired. Single-action hinges are more frequently used, but double-action hinges may be used if desired; with the latter the door is always shut, except in entering or leaving. The single-action hinges are usually "surface" hinges, made to screw to the face of the door and frame, although the "Bommer" and "Draper" may be had with box flange, as in Fig. 417. Most of the better class of spring hinges

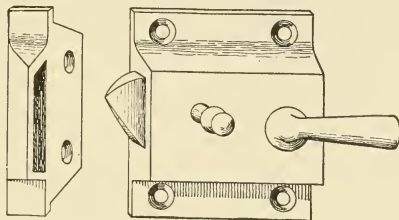
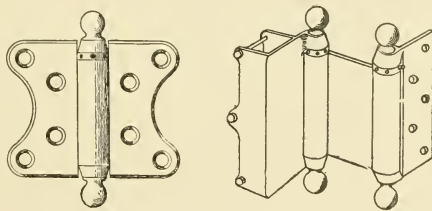

Fig. 416.—Willer Screen Door Catch.

are made in patterns especially adapted to water closet doors, all of the double-acting hinges being made with a box flange to fit over the edge of the marble jamb and where it is secured by bolts.

Draper's single-action spring hinge\* has a box flange with the inside made to adjust  $\frac{1}{4}$  of an inch, to allow for any variation in the thickness of the marble. Single-action hinges set to close



Single-Action Surface Hinge.

Double-Action Box Flange.

Fig. 417.—Bommer W. C. Hinges.

the door, should have a strike with rubber cushion on the jamb for the door to strike against. These may usually be obtained with the hinges. Doors hung with double-action hinges are not usually fitted with any lock or bolt, push plates only being placed on each side of the door. Doors with single-action hinges should have a pull handle

\* Sold by P. & F. Corbin,

on one side, and are usually fitted with a bolt on the inside; special "water closet bolts" are made for this purpose which have an indicator dial on the outside of the door, showing that the closet is occupied when the bolt is shot.

*Office gates* are also usually fitted with spring hinges, and special wide hinges for such gates are made in the "Bommer" line, for both single and double-action. The top rail, however, should not be more than 4 inches wide, when such hinges are to be used.

**235. Door Checks.**—Single-action doors fitted with a spring, whether in the hinge or separate from it, are sure to slam violently (if there is sufficient tension in the spring to close the door), and to avoid this very objectionable feature, several devices for checking the door while closing have been invented, and double-action spring hinges are nearly as often used to prevent the slamming of the door as to permit it being opened either way. Double-action doors, however, cannot be made very tight, and are objectionable in this respect for outside entrances.

It has been found that the most practical forms of door checks are those which are attached to the top of the door and frame, and which are known as "overhead checks."

There are two distinct kinds of door checks; A, those which simply check the door when closed by a spring or by hand, and B, those which both close the door and prevent its slamming. The former class are commonly used with single-action spring hinges, while the latter class are used with ordinary butts. Although several styles of door checks of class A have been patented, the "Eclipse Door Check," manufactured by Sargent & Co., appears to be the most popular and is quite extensively used. It consists of a piston secured to the head of the door frame and working in a cylinder attached to the top of the door. The piston rod is attached in such a way that lateral motion is prevented, while it can be accurately adjusted to meet the cylinder. When the door is opened, the cylinder is drawn entirely away from the piston, while the compression of the air in the cylinder when the door closes, prevents any slamming. The air escapes through openings in the end of the cylinder, so arranged as to be easily regulated. A special spring for closing the door is also made for doors hung with ordinary butts.

*Door Check With Spring.*—It is usually considered more desirable to combine the self-closing and checking features in one piece of mechanism, and two or three of such door checks have been placed on the market which work very satisfactorily. The first of these to

be patented, the author believes, was the "Norton Door Check," in which the checking apparatus consists of a cylinder with a piston working against an air cushion and a strong spiral spring which closes the door. When the door is opened the piston is drawn out, the spring is compressed and air enters the cylinder filling the space between its head and the piston. When the door is released, the spring tends to close it, but the air behind the piston prevents the door from closing too quickly or from slamming. The spring is made sufficiently strong to both close the door and to latch it after the air has escaped from the cylinder. The main part of the check is attached to the head casing of the door, while the arm connecting with the piston rod is attached to the inside of the top rail of the door.

A check and spring (the Columbia) working on practically the

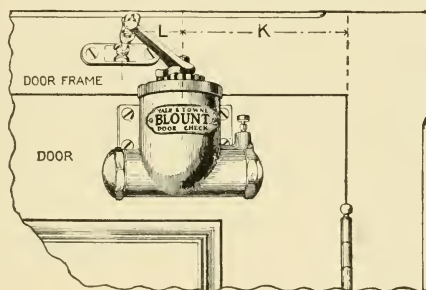

Fig. 418.—Blount Door Check

same principles as the Norton, but with the spring and cylinder differently arranged, is made by the Russell & Erwin Manufacturing Co.

It has been claimed that in all door checks depending upon an air cushion, the bearings will wear loose after having been used for a certain time, so that the air will escape too freely to make a reliable check, and several attempts have been made to produce a practical door check in which some liquid could be used for the cushion, and the author believes the liquid door check and spring to be the latest improvement in the way of a self-closing apparatus for heavy single-acting doors.

Of these liquid door checks, "The Blount,"\* Fig. 418, is believed to be the most satisfactory as well as the most compact and pleasing in appearance. The cylinder portion is attached to the inside of the

\* Yale & Towne Manufacturing Co., sole selling agents.

upper rail of the door from 4 to 6 inches from the hanging edge, and the end of the arm to the head casing.

The check opposes no appreciable resistance to opening the door, but when the door is released the tendency of the spring to close it is regulated by an automatic valve, so that as the door nears the jamb it almost comes to a standstill, and then quietly but positively closes by the operation of the spring.

Overhead door checks with spring, are being more extensively used every year for the entrance doors of public buildings, banks, stores, outside storm doors, etc., and also on the pantry or closet doors of private residences.

#### WINDOW TRIMMINGS.

**236. Double Hung Windows.**—The trimmings or hardware for double hung windows consist, usually, of pulleys, sash cord, chain or tape, the weights for balancing the sash, sash fasts, sash lifts and sash socket.

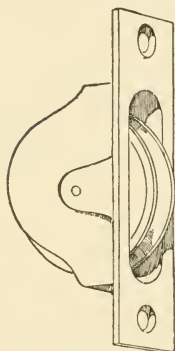

Fig. 419.—Ordinary Axle Pulley.

*Pulleys.*—These are of two styles, side pulleys and overhead pulleys, the former being the style commonly used, and in fact, the only style used previous to about the year 1890.

The general shape of the common side pulley is shown in Fig. 419, although the end of the face plate is as often round as square.

These pulleys consist of a cast or wrought iron frame with a finished face plate and a cast iron wheel working on an axle. Slide pulleys are fixed in a mortise cut into the pulley stile, and the face plate is usually the only portion that is finished.

Millions of very cheap iron pulleys are used every year, and unless the architect takes pains to specify the particular style and finish of pulleys he wishes used, he is quite likely to get a very inferior article. The essential points of a good pulley are that the wheel shall be of sufficient size, have a durable and smooth running axle with broad bearings and that the pulley shall have a neat appearance.

The common stock sizes of sash pulleys are  $1\frac{3}{4}$ , 2,  $2\frac{1}{4}$ ,  $2\frac{1}{2}$  and 3 inches, the size referring to the diameter of the wheel. The Gardner pulleys are made up to  $3\frac{1}{2}$  inches, and the Norris pulleys are made in  $2\frac{3}{4}$  and 4-inch sizes, but not  $3\frac{1}{2}$ -inch. The 2-inch wheel is sufficiently large for sash not exceeding 3x3 feet with double strength

glass, but for larger or heavier sashes, larger sizes should be used, principally for the purpose of throwing the sash cord further into the pocket so as to prevent the sash weight from striking the back of the pulley stile. One and three-fourth inch pulleys should not be specified except for very small windows.

For ordinary purposes a "steel axle" may be specified; in the better grades the axles are turned and are then called "noiseless" pulleys. For pulleys larger than 2 inches, it would be well to specify gun metal or phospho bronze pin, as these are less likely to break. There are also two or three kinds of anti-friction pulleys. The various grades of steel axle pulleys run about as follows: Plain face and wheel; lacquered or amber bronze face, plain wheel; bronze plated face (various finishes), nickel plated face, Bower-Barff face, bronze or brass face iron wheel; bronze or brass face, and bronze or brass face and wheel. A bronze or brass wheel would hardly be warranted except in very expensive work.

There are several variations in the shape of side axle pulleys, but they are mostly in the cheaper grades where special study has been made to reduce the labor of fitting them to the frame. Such pulleys are usually too cheap to specify. The principal variation from the common shape amongst good pulleys, is that of the Norris pulley, Fig. 420. In this pulley the face plate and case are cast in one piece, with a heavy beveled shoulder on the lower end which, when fitted into position, prevents the pulley from slipping down or out, so that the pulley does not depend upon screws to hold it in position.

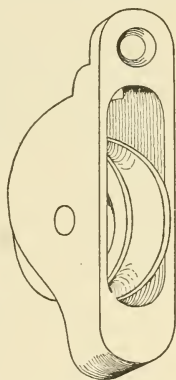

Fig. 420.—Norris Sash Pulley.

Sash pulleys are made by a great many different firms, but only a few make a specialty of the better grades. The manufacturers of the Norris pulleys make probably the greatest variety, several of their grades being of great excellence of construction. They are made for cord, tape or chain, the chain wheels having a groove especially designed to fit the usual shape of chains.

The Gardner Sash-Balance Co., also makes a large line of sash pulleys especially adapted to their sash ribbon.

**237. Overhead Pulleys.**—These pulleys differ from the side pulleys in that they are made to apply *above* the pulley stile, which

necessitates a different shape for the case. The first overhead pulley (Shull's) was patented in August, 1895, and was placed on the market early in the same year. Overhead pulleys certainly possess advantages over the side pulley, and their use will doubtless be largely extended in the near future.

The principal advantages are that they give 8 inches more play for

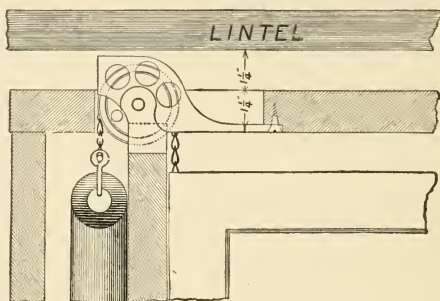

Fig. 421.—Queen Overhead Pulley.

the weights than the side pulley, and the wheel is not exposed, neither is there any opening to be seen. The face plate being mortised into the underside of the yoke, is not as conspicuous as when set in the pulley stile, and in a window fitted with shades, can hardly

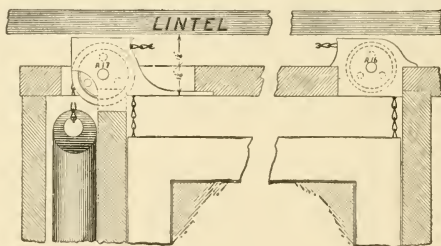

Fig. 422.—Queen Mullion Frame Pulleys.

be seen at all. Overhead pulleys cost no more than side pulleys of the same grade. The only serious objection that has been offered to the "Shull" pulley, is that more than the usual head-room above the top of the frame is required. This has been overcome in the Queen

pulley, which requires but  $1\frac{1}{4}$  inches between the yoke and lintel, as shown in Fig. 421, which space is usually allowed, even when side pulleys are used. Both the Shull and Queen pulleys are made for cord, tape or chain.

The Queen pulley is especially convenient for mullion windows, in which it is desired to do away with the pockets in the mullion, the pulleys being arranged as shown in Fig. 422, one weight balancing each sash.



Fig. 423.—Monarch Sash Chain.

**238. Sash Cords, Chains and Ribbons.**—Until within a few years past, linen or cotton cord was alone used for connecting the weights with the sashes of double hung windows, and cord is still more extensively used than either ribbons or chains. For windows of ordinary size a

good braided cord will wear for a long time, and this material will probably never be entirely displaced by metal.

The architect, however, should always specify the particular brand of cord to be used and also the size. The leading brands at present are the Samson spot cord and the Silver Lake sash cord, both of which are superior to the ordinary braided cords. The Samson cord offers one advantage that architects will appreciate, in that it has a colored strand woven through it, which shows in spots on the surface and thus enables the architect to tell at a glance that no other cord has been substituted. The Silver Lake sash cord is now marked every three feet. The following numbers should be specified for different heft of weights :

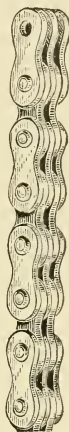

Fig. 424. Cable Chain.

For sash weights of . . . . .	10 to 15 lbs.	15 to 25 lbs.	25 to 35 lbs.	35 to 45 lbs.
Samson Spot Cord, No. 7	$(\frac{7}{32}$ -inch.)	8	$(\frac{1}{4}$ -inch.)	9
Silver Lake Cord, No. 7A	$(\frac{7}{32}$ -inch.)	8A	$(\frac{1}{4}$ -inch.)	9A
				$(\frac{9}{32}$ -inch.)

**Chains.**—For hanging sashes weighing over 40 pounds, only the largest size of Samson or Silver Lake Cord, shoe thread cord, or some form of sash chain or ribbon should be used, and the pulleys should be selected to fit the cord or chain. (See note on page 522 g.)

There are several styles of sash chains in the market, the style most largely used being the flat link chain, of which, perhaps, the best pattern is shown in Fig. 423. For suspending very heavy sashes, doors and gates, the cable chain, shown in Fig. 424, has been extensively used.

The manufacturers of the Norris pulleys, however, claim that a riveted chain having joints only one way is almost sure to break when even slightly twisted, and that it is better to use two chains of the link pattern running side by side over the same pulley.

The strongest sash chains are made of a bronze mixture which looks like copper, but is tougher and harder.

*Sash Ribbons.*—These are now also extensively used in hanging the sashes of the better class of buildings. The ribbons are made of steel and aluminum bronze or of some mixture of aluminum, and in  $\frac{3}{8}$ ,  $\frac{1}{2}$ ,  $\frac{5}{8}$ ,  $\frac{3}{4}$  and  $\frac{7}{8}$ -inch widths. They are claimed to be practically indestructible, and work easily and without noise. The  $\frac{3}{8}$ -inch ribbon may be used for sash weighing up to 100 pounds (50 pound weights). For a window 6 feet 10 inches high and 3 feet wide, glazed with plate glass, the ribbons with attachments will cost about 75 cents.

Sash ribbons are now manufactured by a number of firms who also make the necessary attachments for weight and sash.

For the best working of windows hung with ribbons, the following size pulleys should be used:

For sash weighing not over	40 pounds,	2	-inch.
"	"	60	" 2 $\frac{1}{2}$ "
"	"	100	" 2 $\frac{3}{4}$ "
"	"	150	" 3 "
"	"	250	" 3 $\frac{1}{2}$ "
"	"	300	" 4 "
"	"	350	" 4 $\frac{1}{2}$ "

**239. Weight of Sash and Glass.**—In figuring the weight of windows, the weight of the glass may be taken at  $3\frac{1}{2}$  pounds per square foot for plate glass,  $1\frac{1}{2}$  pounds for double strength glass and 1 pound for single strength glass.

For the weight of the wooden sash, add together the height and width of each sash (in feet) and multiply by 2.1 for  $2\frac{1}{4}$ -inch sash;  $1\frac{3}{4}$  for  $1\frac{3}{4}$ -inch sash, and  $1\frac{1}{2}$  for  $1\frac{3}{8}$ -inch sash.

The above data is sufficiently accurate for determining the size of sash cords and pulleys, but the weights should be determined by weighing each sash after it is glazed as the weight of the glass will vary considerably.

*Sash Weights.*—The weights ordinarily used for balancing windows are made of cast iron, in the form of a solid cylinder,  $1\frac{1}{2}$  or  $1\frac{3}{4}$  inches in diameter, with an eye cast in the upper end. The length varies with the weight.

Ordinary weights have very rough eyes for the sash cords. There are a few manufacturers in the East that make weights with a patent eye that will not cut the cord.



*Lead Weights.*—It often happens that for wide and low windows the weights if of iron would be so long that they would touch the bottom of the pocket before the bottom sash was fully raised. In such cases lead weights are usually resorted to, lead being 80 per cent. heavier than cast iron. By casting the weights *square*, whether of iron or lead, considerable saving can be made in the lengths.

The Raymond Lead Co., of Chicago, makes a specialty of compressed lead sash weights, with wrought and malleable iron fastenings centred so that the weight will hang perfectly plumb, and when lead weights are necessary the architect will do well to specify their weights.

In hanging the sashes the weights for the upper sash should be about  $\frac{1}{2}$  pound heavier than the sash, and for the lower sash  $\frac{1}{2}$  pound lighter.

**240. Sash Balances.**—Within a comparatively few years several devices have been patented for balancing sashes by means of springs instead of weights, but the author believes that only one type known as the "sash balance" has proved a practical success. The sash balance consists of a drum on which the cord or ribbon is wound, and containing a coiled steel clock spring which sustains the weight of the sash. The common type very much resembles in outward appearance the ordinary sash pulley, and is applied in practically the same way, the ribbon or cord being attached to the sashes in the same way as when used with weights.

While the sash balance in its best form works very satisfactorily, it will probably never supplant the weight and axle pulley for ordinary windows. There are many windows, however, for which sufficient pocket room for weights cannot be obtained without spoiling the effect desired or narrowing the glass, as in the bay window, Fig. 115, or where it is undesirable to break the frame into the brick jamb, and in such cases the sash balance is almost invaluable. For hanging the glass doors of show cases also, sash balances are usually preferable to weights. Sash balances are made in both side and top patterns, but the former are recommended wherever there is room at the side of the frame for the depth of mortise required. For windows of the sizes usually found in residences, the depth of the sash balance measured from the face of the pulley stile will vary from 3 to 4 inches, and this can usually be provided by cutting a small hole in the masonry or studding back of the frame if necessary.

"Tandem" and "quad" tandem" balances are made that will operate sash weighing up to 600 pounds. The tandem balances are

recommended for all sashes weighing over 30 pounds, as the strain being divided, there is less wear and liability to breakage, and less depth of pocket is required.

Sash balances require only a plank frame, and the consequent reduction in the cost of the frame offsets the extra cost of the balance.

In remodeling old buildings having plank frames without weights, sash balances will be found a great convenience, as they can easily be inserted in the old frames.

An advantage which all spring balances possess is that they act most strongly when the sash is down, enabling one to move a binding window more readily than if it were hung with weights, while when the sash is up the springs barely suffice to hold it in position, and do not offer resistance to drawing down. Sash hung with spring balances should be provided with self-locking sash lifts, otherwise the lower sash might slide up.

Of the various sash balances on the market, the Pullman and Caldwell are believed to be the most extensively used, and are undoubtedly reliable. The Pullman Sash Balance Co. makes a very extensive line of sash balances adapted to all possible uses.

**241. Sash Fastenings.**—There is such a great variety of sash fasts in the market that it will be possible to mention but a few. In general, sash fasts consist of two plates secured one to each meeting rail and provided with a bar, catch or cam that locks the two plates, and consequently the two sashes together.

The requirements of a good sash fast are that it shall be burglar-proof, draw the sashes tightly together so as to prevent rattling, be easy to operate and neat in appearance.

The principal point in regard to the burglar-proof quality of the fast is that it shall be constructed so that when locked the arm cannot be forced back by a knife blade inserted from the outside between the sashes. The arm or catch should also have sufficient strength that it will not readily be broken by prying up the lower sash, although any window can be opened by using sufficient force.

A great change has taken place in the design of the sash fasts in common use during the past fifteen years. Most of the older styles had a spring attached to the arm which forced it either open or shut, but spring sash fasts are now comparatively little used. The old-style fasts also, were not as a rule efficient for drawing the sashes together, while the later styles are made with this object especially in view.

Probably the most popular style of sash fast at the present time is the cam sash fast, shown in Fig. 425, which consists of two levers fastened to the lower sash and working on the cam principle.

When the upper lever is turned the lower or locking lever, *A*, is first thrown out until released from the hook on the upper sash, and then drawn around, and in toward the hub until both levers are on a

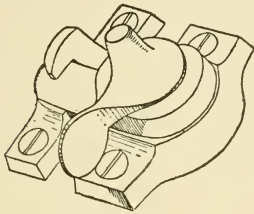

Cast Metal.

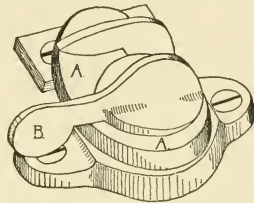

Wrought Metal.

Fig. 425.—Cam Sash Fast. (Ives.)

line with the edge of the sash, the upper lever moving through 180 degrees, while the lower lever is moved only 90 degrees. The fast is very simple in its construction, and there is nothing about it that can get out of order.

One great advantage of the "cam" sash fast is that there is considerable play, in and out, to the locking lever, so that if the sashes are at all loose the locking lever, by the action of the cam, draws

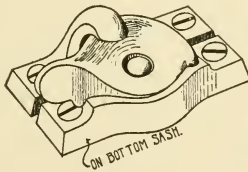

Fig. 426.—Fitch Sash Lock.

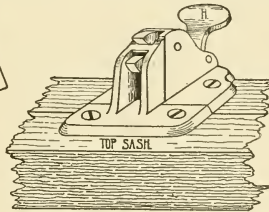

Fig. 427.—Gale Automatic Sash Lock.

them tightly together, and so prevents the sashes from rattling in a storm. The locking lever cannot be forced back from the outside.

The cam sash fast was first brought out by Hobart B. Ives & Co., but there are now several other cam sash fasts in the market that are made on practically the same principle and in very nearly the same

shape; most of these, however, are inferior to the Ives. The Ives fasts are made of both cast and wrought metal in two sizes and several different styles of finish. Fig. 426 shows an entirely new form of sash lock recently placed on the market, which is neat in appearance, very simple in construction and works nicely. This fast is so designed that it will both raise the upper sash and draw it into

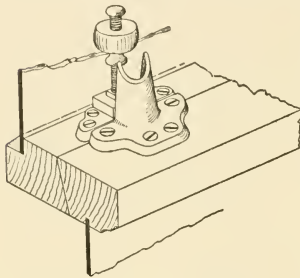

Fig. 428.—Yale Screw Sash Fast.

the lower one, the lever engaging in the hook plate on the upper sash even when the sash is dropped  $\frac{3}{8}$  of an inch. Two flat springs within the lever plate keep the lever either closed or open, although the security of the lock does not depend upon them.

The Yale & Towne Manufacturing Co. makes a sash fast (Fig. 428) that is rather a novelty, but which would appear to be especially desirable for windows that are not likely to be often opened, as it acts to draw the sashes firmly together and at the same time forcing them against the top and bottom of the frame. It does not appear to be quite as convenient for ordinary purposes as the fasts shown in Figs. 425 and 426. In order to obtain the best results from cam sash fasts, however, the plates require to be carefully adjusted on the frame, while the screw sash fast has considerable latitude. Several self-locking sash fasts have also been patented, but very few of them have become popular.

Fig. 427 shows what is believed to be the latest self-locking sash fast, and one that seems to be as good as any. The locking catch works by the action of gravity and the window cannot be closed without automatically locking the sashes. This lock would appear to be especially convenient for high windows where the meeting rails are 6 feet or more from the floor, as it can be locked by simply closing the sashes, and to unlock, it is only necessary to push up on the lever *H*.

There are also several ventilating sash locks which lock the window in different positions when partly open. The Pennington ven-

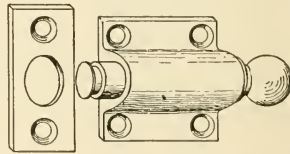

Fig. 429.—Ventilating Sash Bolt

tilating sash lock, and the Rollins automatic window lock are believed to be the only ones that have proved to be much of a success.

The simplest device for locking the sashes when partially open is the sash or ventilating bolt, Fig. 429, of which several patterns are made in solid bronze. A lug on the inside of the case keeps the bolt drawn when desired, and by slightly turning the knob the bolt is released and shoots into the strike. The bolt is placed on top of the meeting rail of the lower sash and the strike on the stile of the upper sash.\* Usually three strikes are placed on the upper sash at intervals of about 2 inches from the meeting rail, so that either sash may be opened 2 or 4 inches as desired. A regular sash fast may be used with this bolt if desired, as although the bolt will lock the sashes when closed, it will not prevent their rattling if loose.

For all first-class work sash fasts should be of bronze metal, but a great many iron fasts lacquered or bronze plated are used. The difference in cost for an ordinary residence, however, hardly warrants the use of the cheaper goods.

**242. Sash Lifts.**—These are applied to the bottom rail of the lower sash to afford a hold for the fingers when raising the sash.

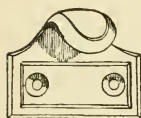

Fig. 430.—Ordinary Hook Sash Lift.

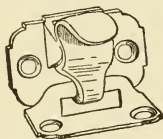

Fig. 430a.—Sash Lift and Lock.

They should always be specified for plate glass windows and for all sash 3 feet wide and over.

Sash lifts are of four kinds: 1. The flush sash lift (see *E*, Plate III.),

which is mortised into the rail of the sash so as to be flush, or nearly flush with it. 2. The hook sash lift, the most common style of which is shown in Fig. 430. This is about the most convenient shape to take hold of, and is the shape most largely used. 3. Bar sash lifts which are of the shape shown in Fig. *F*, Plate III., and may be obtained either plain or ornamented. For very heavy windows the flush or bar sash lifts are best, as several fingers can be inserted into the lift. The flush sash lifts are also neater in appearance. 4. Sash lifts and locks combined. One of the most practical styles of these combined sash lifts and locks is shown in Fig. 430a. The hook is fastened with a pivot and terminates in a second hook, which catches over a plate screwed on to the sill. The upper part of the lift is forced out by a spring. Flush lifts with lock catch may also be had if desired. These locks should be used where there is but one sash to the window, or when the sashes are hung with spring balances.

Fig. 431 shows a sash lift intended to go on the stile of the sash about half way up (made by the Willer Manufacturing Co.), that is very convenient for the ordinary windows of residences, as it can be used equally as well for raising or lowering the sash; it will be found especially convenient on the upper sash, as well to lower it as to raise it.

*Sash pull plates or sockets*, being small brass plates with a round hole or socket, are often screwed to the top rail of plate glass windows for pulling down the sash. A pole is used for this purpose with a hook, called a sash pull, on the end of it which fits into the socket on the sash.

The use of sash pulls and sockets prevents the sash from being racked and strained and are a great convenience. They should be of solid bronze on all but the very cheapest work.

*Stop Adjusters*—It is becoming the custom in good buildings to secure the stop beads of the windows, and also of sliding doors with screws passing through an elongated hole in a round plate or socket let into the stop. The elongated hole or slot is placed

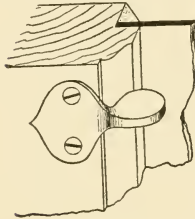

Fig. 431.—Willer Sash Lift.

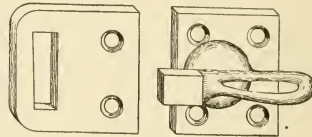

Fig. 432.—Turnbuckle for Casement Windows.

at right angles to the sash so that the stop can readily be moved in or out as the sash swells or shrinks. They may be obtained in all finishes with screws to match. They cost from  $12\frac{1}{2}$  to 25 cents a dozen in ordinary finishes.

**243. Single Casement Windows.**—These are best hung with a pair of light, loose-pin bronze metal, or Stanley bronze-plated or japanned butts. They may be secured with a common latch or bolt, or by a double extension bolt. For windows not more than 3 feet high and opening in, a simple casement latch or turnbuckle, like that shown in Fig. 432, will generally prove satisfactory, as the strike is so arranged as to force the sash tightly against the rebate, and so short a sash is not likely to spring very much.

When the sash is over 4 feet high, however, a double extension bolt or an espagnolette bolt should be used, as if the sash is secured

only in the centre it will be likely to spring badly at the top and bottom.

The mortise double extension bolt, shown in Fig. 433, makes a very neat finish and a very strong fastening.

The Cremorne bolt, shown in Fig. 400, page 374, is really a rim double-extension bolt, operated on the same principle, it makes a very handsome trimming for casement windows opening in or out.

Casement windows may also be fitted with a mortise lock and latch with lever handle, special narrow locks being made for the purpose.

**244. Double Casement Windows, or French windows**

usually have the meeting stiles rebated, so that when the swing leaf is secured it will also secure the standing leaf. The best fastening for a French window is believed to be either the mortise

double-extension bolt or the espagnolette bolt or bar. The latter is much used in France, and possesses an advantage over the extension bolt, in that it is arranged so as to draw the sash

firmly against the window frame, thus making more secure against the weather.

Fig. 434 shows a double-rim espagnolette bar, made by the Yale & Towne Manufacturing Co., which not only secures the

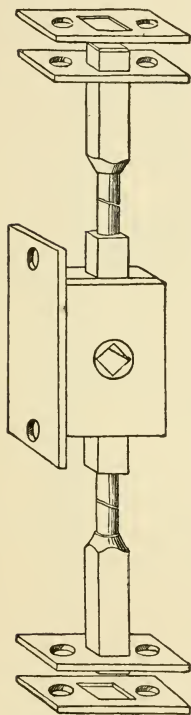

Fig. 433.—Double Extension Bolt.

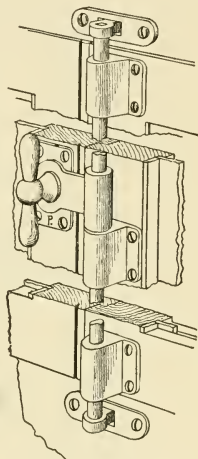

Fig. 434.—Double Rim Espagnolette Bar.

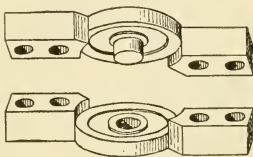

Fig. 435.—Heavy Sash Centre for Vertical Swing.

sashes but locks them together and draws them closely to their place. The operation of the bar is as follows: By turning the T-handle, the hasp is released from the locking plate, *P*, on the standing leaf, and by turning the handle back the bar is revolved and the hook is released from the strike at the top and bottom of the door.

A mortise espagnolette bar, working on the same principle is made by the Russell & Erwin Mfg. Co., and by P. & F. Corbir. If it is

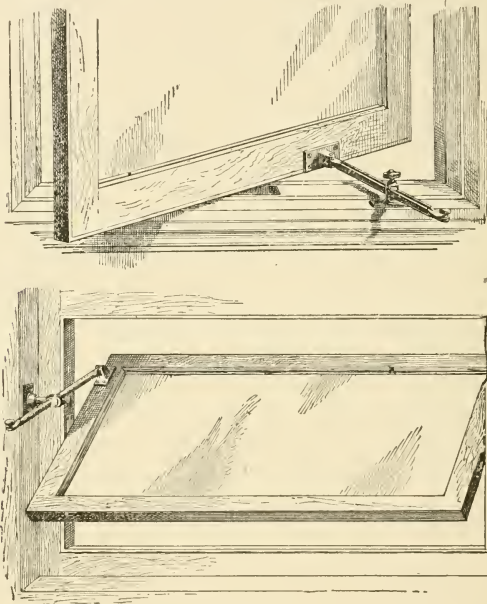

Fig. 436.—Sash Adjusters.

desired to secure the standing leaf independently of the other, a flush bolt may be used at the top and bottom, but as it is usually desirable to open both leaves of a French window when operated at all, it is more convenient to use a single double-extension bolt or espagnolette bar.

**245. Pivoted Windows.**—As stated in Section 99, it is often desirable to pivot windows consisting of a single sash and especially those that are of an irregular shape. For windows of moderate size,



pivoted at the sides, the sash centre shown in Fig. 410 may be used. Very heavy or large windows should be pivoted at the top and bottom, and for such windows the style of sash centre shown in Fig. 435 is preferable. This centre is made 4 and 5 inches long and  $\frac{1}{2}$  inch thick, and should be of bronze metal that it may not rust.

Windows pivoted top and bottom should be provided with a sash adjuster (of which one pattern, the Yale, is shown in Fig. 436), that

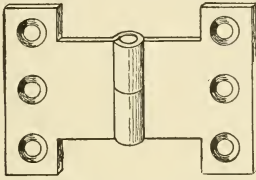

Fig. 437.—Parliament Butts.

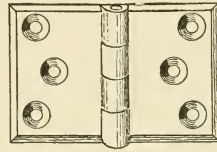

Fig. 438.—Surface Shutter Hinge.

will hold the sash in any position. Sash adjusters also make the best trimming for a window pivoted at the sides, unless the window is so high that the adjuster cannot be readily reached, when a transom lifter may be used.

The Howarth Reversible Sash and Sash Centre Co., makes an automatic spring sash centre that they claim will hold any sash in any desired position. The centres are made in different sizes,

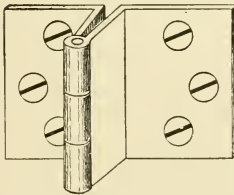

Fig. 439.—Three-fold Shutter Flap.

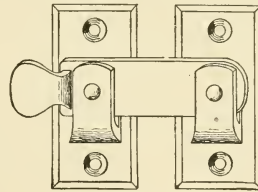

Fig. 440.—Shutter Bar.

adapted to the smallest or the largest plate glass window and for either vertical or horizontal swing.

**246. Shutter Trimmings.**—The usual trimmings for inside shutters are the hinges, shutter bar and knob. The outer or hanging fold may be hung with narrow blind butts ( $2 \times 1\frac{1}{2}$  inches) similar to the one in Fig. 408, but usually with three screws to a side and five knuckles. If it is necessary to throw the shutters out to clear the finish, parliament butts, Fig. 437 should be used. These come

in widths of  $2\frac{1}{2}$ , 3,  $3\frac{1}{2}$  and 4 inches. For hanging the folds to each other,  $1\frac{1}{4}$  or  $1\frac{1}{2}$ -inch surface hinges, similar to that shown in Fig. 438, are generally used.

When the shutters are divided into six folds, three to a side, the second fold should be hung with "three-fold shutter flaps" (Fig. 439), applied to the inside face of the shutters, as shown in Fig. 250.

The usual method of fastening shutters at the centre is by shutter bars of the general pattern shown in Fig. 440. These bars are made reversible so that they can be used for either hand. To pull the shutters from the pocket, a small knob of porcelain or bronze should be placed on the outer face of the hanging fold. Special "shutter knobs" are made for this purpose, and in diameters of  $\frac{3}{8}$ , 1 and  $1\frac{1}{8}$  inches. Sets of ornamental hardware usually contain shutter bars and knobs to match, and they are susceptible of very ornamental treatment.

247. Trimmings for Outside Blinds.—*Hinges.*—The kind of

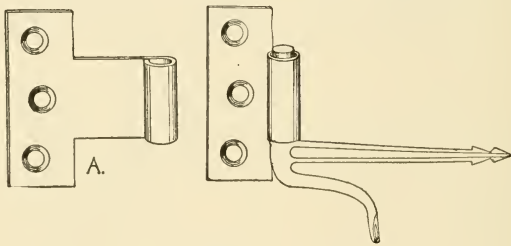

Fig. 441.—Wrought Steel Blind Hinge.

hinges to be used with outside blinds will depend to some extent upon how the blind is hung to the window frame.

In New England the blinds are generally hung on the outside of the casing, and the hinges consist of a half hinge on the edge of the blind and a hook driven into the face of the casing. Fig. 441 shows the more common type of such hinges, the position of the parts being that assumed when the blind is thrown open. Two sizes of plates are made, 2 and  $2\frac{1}{2}$ -inch, the latter affording a more secure attachment.

If there is a moulding on the casing, a wider hinge plate and longer hook must be used to throw the blind beyond the moulding, and hinges with 2 and 4-inch "throw" are made for this purpose, the hinge plate being of the shape shown at *A*. The hinge with

4-inch throw may be used on brick buildings, with 4-inch reveal to the windows. These hinges are very simple and inexpensive, and being made of steel will not break.

Fig. 442 shows a style of wrought steel hinge much used in New York City, where blinds are usually set flush with the outside casing. The angle plate is screwed to the outside face of the blind and serves to strengthen the latter as well as to give a firm attachment. The bend near the eye is to give a throw to the hinge. A similar hinge with a 4-inch throw is made for windows in brick buildings.

An objection that may be offered to all of these hinges is that the blind swings readily on them in any position, and a catch is required to hold them open and another to secure them when closed.

The more recent improvements in blind hinges, therefore, are in the way of hold back or

"gravity" hinges as they are called, which lock the blind when thrown open, and prevent its slamming. There are several patterns of these gravity hinges in use, particularly in the Western States, and as a rule they have proved very satisfactory. Probably the simplest

pattern is that shown in Fig. 443, which is forged from steel plates and hence is non-breakable and very inexpensive. When the blind is thrown back, the hook *A*, engages in the hole *H*, and securely locks the blind. To close the blind it is lifted bodily until the hook clears the hole, when

it is readily swung too. The hook *B*, prevents the blind from being raised entirely from the hinge, and the two parts can be separated only when the blind is exactly at right angles with the house. The top and bottom hinges are exactly alike, and they can be used either right or left hand.

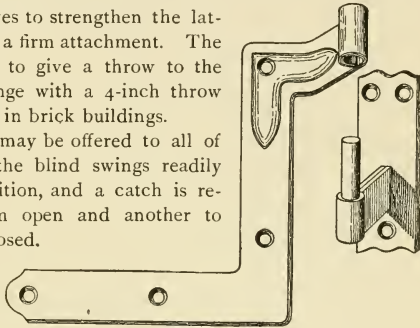

Fig. 442.—Wrought Blind Hinge. New York Style.

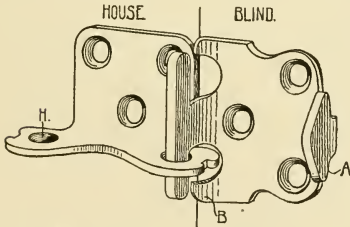

Fig. 443.—Stanley Gravity Blind Hinge.

The Stanley Works also make a heavier wrought steel hinge, which locks the blind by the action of gravity, and has also the unusual feature (for gravity hinges) of enabling the hinge to be unlocked without lifting the blind.

All other gravity hinges with which the author is acquainted, are made of malleable iron. Fig. 444 shows one of the latest patterns.

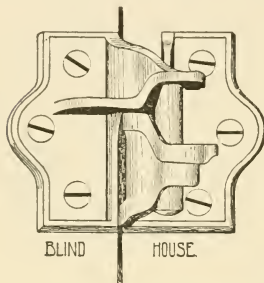

Fig. 444—Ideal Blind Hinge.

One object in making this hinge was to obtain a hinge that would not project into the window opening when the blind is thrown back, thus leaving the entire opening between the architrave or casings clear for storm windows. A good feature of this hinge is that the screw holes are well back from the edge of the casing.

Both of these types of gravity hinges are made for blinds hung flush with the outside casings or architraves, as in Fig. 96, and they throw the blind only about  $\frac{3}{4}$ -inch away

from the house. Several forms of malleable iron gravity blind hinges, designed for brick buildings, are used in the Western States, the Clark and Shepard giving perhaps as good satisfaction as any.

*Awning Hinges.*—Two or three styles of blind hinges have been patented which permit the blinds to be thrown out at the bottom like an awning, as well as to open and close in the ordinary way. One style, the automatic blind awning fixture, has been very extensively used about Boston, and seldom fails to give satisfaction. The fixtures are sold with side bars to hold the bottom of the blind away from the building, and also with a device for fastening the blinds together. It permits the blinds to be used either way at will, and the operation is very simple.

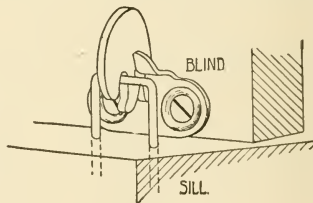

Fig. 445.

**248. Blind Fast.**—When gravity hinges are used, the only fastening required is a catch to secure the blind when closed. Fig. 443 shows the catch sold with the hinge, Fig. 443, which, although very simple, works nicely. The catch is screwed to the inside of the bot-

tom rail of the blind; when the blind is closed, the plate *A*, catches automatically over a staple driven into the sill. Fig. 446 shows an improved catch made by the same firm, which works on the same principle, but cannot be as easily opened from the outside. There are several other catches quite similar to these.

For blinds hung with hinges similar to those shown in Figs. 441 and 442, it is necessary to use a catch that will secure the blind either when open or when closed. Most of the catches for securing the blind in both positions are made to go underneath the blind; there are a great many patterns, but as a rule, the simplest catch is the most satisfactory. The catch shown in Fig. 447 is very much used in New England, and gives general satisfaction. The end of the wire is screwed into the bottom of the blind, and the staple *S*, is also driven into the blind. The hook *H*, is driven into the window sill and engages the fast when the blind is closed. The back catch is driven into the wall to engage the fast when the blind is thrown back.

Underneath catches can, of course, only be used when there is a space of at least  $\frac{5}{8}$ -inch between the blind and the sill. If the blind fits into a rebate in the sill, as in Fig. 96, a mortise blind fast, or one

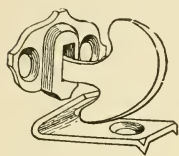

Fig. 446.

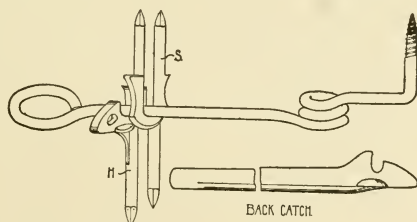

Fig. 447.—Stanley's Wire Blind Fast

made to screw through the blind, must be used. Fig. 448 shows Hyde's patent gravity blind fast, which is made to drive through a hole bored through the bottom rail. It has double lock levers, and the inner one cannot be operated from the outside when the blind is closed. A common staple is used for the sill catch.

To close a blind hung with the ordinary gravity or hold back hinge, or with a simple hinge and back catch, it is necessary to reach

far out of the window to raise the blind bodily or to release the catch. To overcome this difficulty, several devices have been patented which operate either from the hanging stile of the blind or from the sill, and are intended to secure the blind whether open or shut; others adjust the blind to any position and hold it there, while still others

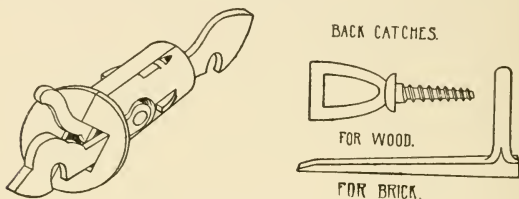

Fig. 448—Hyde's Gravity Lock Blind Fast.

are designed to operate the blinds without opening the window. Very few of the devices of the first and second class appear to be used to any extent, but a practical device that will open or close the blind and lock it securely without opening the window, is certainly a very desirable equipment for residences. Several devices that accomplish this purpose have been patented, but the author knows of none that has proved a practical success.

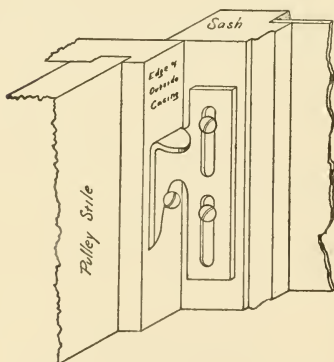

Fig. 449.—Moore's Storm Window Fastener.

**249. Trimmings for Storm Sash.**—In many of the very Northern States it is a quite general custom to place a single storm sash or outside window over the whole window opening to keep out the cold during the winter months.

In many cases the storm sash is permanently secured to the window frames by screws, the sash being put up in the fall and taken down in the spring. The use of screws, however, involves considerable labor and leaves unsightly holes in the outside casings, so that it is desirable to use some fastening

that will enable the sash to be quickly and easily put up, and that will not look bad on the house.

The simplest fastening that the author has seen is the one shown in Fig. 449, which is fastened to the inside of the storm sash while the hook slips over the shank of a round headed blued screw, placed in the edge of the outside casing or blind stop. The wedge shape of the hook enables the storm sash to be brought tight against the casing, and also facilitates putting up and removing the sash. Two of these fastenings should be used on each side of the sash.

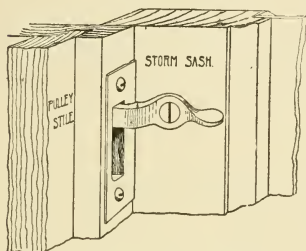
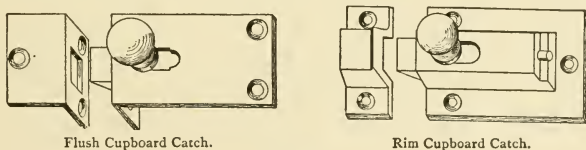

Fig. 450 — Willer Storm Sash Fastener.

Fig. 450 shows another simple device for fastening storm sash or outside screens. The "button" is screwed to the inside face of the storm sash, and when turned the outer end fits into a mortise in the edge of the casing, which is covered with a

brass plate. The plate has a spring lap bent into the mortise, which keeps the button in position. The window may be hung at one side with loose joint butts (which should have a short thick pin, fitting rather loosely), with one of these buttons used on the other side, or two buttons may be used on each side. The buttons are made in cast iron, copper finish with brass plate, and in bronze metal with



Flush Cupboard Catch.

Fig. 451.

Rim Cupboard Catch.

brass plate, the bronze being preferable. Where outside screens covering the entire window are used, this button may be used on both the screen and storm sash, the buttons being adjusted to the same socket plates.

**250. Cupboard Trimmings.**—The small cupboard doors of pantries are usually trimmed with narrow fast joint butts of the pattern shown in Figs. 408 and 409. In the cheaper residences iron butts,

laquered, are commonly used, but brass or bronze, or bronze-plated butts look much neater.

Two general styles of fastenings are used, viz.: the cupboard "catch" and the cupboard "turn." The principal difference between them is that in the "catch" the latch is drawn back by sliding the knob, while the latch of the "turn" is drawn back by turning the knob. Cupboard catches are made both flush and rim, as in Fig. 451, but the turn is only made in the rim pattern. Several ornamental cupboard turns may be found in the market especially suitable for the glass doors of the china closet. The Russell & Erwin catches

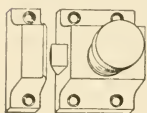

Fig. 452.—Cupboard Turn.



Fig. 453.—Elbow Catch.

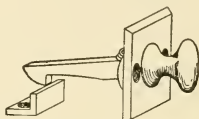

Fig. 454.—Lever Catch.

and turns are made with both the common latch and an anti-friction latch.

Where cupboard doors are used in pairs, the standing leaf is usually

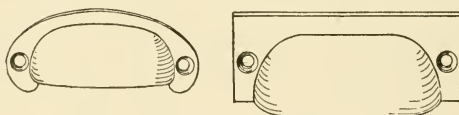

Fig. 455.—Drawer Pulls.

secured by an elbow catch (Fig. 453) placed on the back of the door with the strike fastened to a shelf or to the top of the cupboard.

Fig. 454 shows a lever cupboard catch that works rather better than the surface catch, where there is a shelf about opposite the middle of the door.

*Drawer pulls* are made in a variety of shapes and sizes, the more common shapes, perhaps, being those shown in Fig. 455. Fig. 456 shows a style of pull with a plate for a label, that is known as a "druggist's drawer pull." The drawers of cabinets and furniture are commonly trimmed with "drop

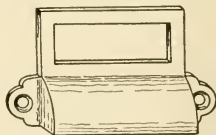

Fig. 456.—Druggist's Drawer Pull.



drawer pulls," consisting of a drop handle attached to a plate that is bolted to the front of the drawer. They are made in a variety of patterns and usually in brass or bronze metal. The common drawer pull is sold more largely in cast or wrought iron, laquered or bronze-plated, although it may be obtained in solid bronze. An ornamental pull is shown in the group, Plate I.

For *clothes hooks* there is nothing better than the triple cast iron clothes hook, japanned finish, except the same shaped hook in brass or bronze. A special upright hook is made for hats. It should be remembered that any iron hook on which damp clothes or cloths are to be hung will rust after a while, hence the hooks in bathrooms, toilet rooms, etc., should be of bronze or brass. The japanned finish for iron will resist rust longer than the other finishes except the Bower-Barff.

**251. Prices of Hardware.**—Unfortunately the cost of finished hardware, like nearly everything else that goes into a building, must generally be considered by the architect in preparing his specifications. It should be remembered, however, that the cheapest hardware is not as a rule, the most economical, and very seldom gives satisfaction. Extra finishes, of course, are merely for ornament, but the difference between cast iron and bronze, or between cast iron and steel, is not one of appearance and expense only, but of toughness and durability, and often in the wear and working of the article. Trimmings of an inferior quality should be avoided as far as possible, and as a matter of fact, the saving between a fairly good article and an inferior one amounts to a very small sum for an ordinary residence.

For convenience in making an approximate estimate of the hardware trimmings, and for comparison between the different grades of goods, prices for the more common of plain trimmings are given below. When it comes to ornamental trimmings the variation in ornamentation and finish are so great that it would require a small book to cover them.

These prices are intended to represent about what the contractor has to pay, and not the retail price. The discounts from manufacturers price lists vary to such an extent, and are often so complicated, that as a rule the catalogue price gives little idea of the actual cost.

*Cost of Butts and Hinges. Per Pair.*

4x4 cast iron butts, ball tipped, japanned finish, 20 cents.

4x4 cast iron butts, ball tipped, bronze-plated, 35 cents; same with steel washers, 40 cents.

5x5 cast iron butts, ball tipped, japanned finish, 27 cents; same bronze-plated, 55 cents; with steel washers, 60 cents.

4x4 Stanley steel butts, ball tipped, japanned finish, 25 cents; same bronze-plated and planished, 30 cents; same bronze-plated and polished, 40 cents; same Bower-Barffed, 60 cents; with steel washers add 25 cents for loose-pin butts, and 5 cents for loose-joint butts.

4x4 Stanley loose-pin butts, raised ornamentation, old copper sand finish, 70 cents.

4½x4½ Stanley steel butts, ball tipped, japanned finish, 30 cents; same bronze-plated and polished, 50 cents.

For Stanley ball-bearing butts, add 50 cents for 4x4 loose-pin butts, and 35 cents for 4x4 loose-joint butts; and 60 cents, and 40 cents respectively for 4½x4½ and larger butts.

5x5 Stanley steel butts, loose-pin, polished and bronzed, 65 cents; loose-joint butts with steel washers, 5 cents extra.

2½x2½ light loose-pin butts, solid bronze, 25 cents.

Two or 2½-inch wrought narrow butts, coppered, 7 cents; same in solid brass or bronze, ball tipped, 25 cents.

Double-action spring butts, for 2 feet 6 inches by 7 feet by 1¾-inch door, japanned finish, \$2.50; plain bronze, \$5.00.

By using one blank, 50 cents may be saved with japanned finish, and \$1.00 in plain bronze.

Bommer double-action hinges (no blanks), \$2.60, japanned; \$7.00 in bronze.

#### *Inside Door Locks (without trimmings).\**

3½-inch mortise cast knob lock, cheapest one-lever, bronze face and bolt, 25 cents.

Sargent's best one-lever, cast lock, 4¼-inch, with steel levers, fifty changes, 60 cents.

Sargent three-lever, 4¼-inch, bronze face and bolt, steel levers, 66 cents.

Sargent three-bolt chamber door lock, one-lever, bronze face and bolts, 95 cents.

Junior lock, one lever, 3½-inch, 23 cents; Vulcan lock, 3½-inch, three levers, 66 cents; Vulcan lock, 4-inch, 75 cents; Vulcan three-bolt chamber door lock, \$1.45; Vulcan communicating door latch (Fig. 383), \$1.33.

Hotel lever locks, master keyed, cost from \$1.25 to \$4.00 each; cylinder escutcheon hotel locks, master keyed, from \$3.25 to \$5.00 each.

\* All locks in this list have bronze face and bolts.

Master keying of lever or tumbler locks costs from \$1.50 to \$3.00 per dozen locks, over the same locks not master keyed.

*Front Door Locks with Trimmings. Single Door.*

A good three-lever front door lock, swivel spindle and ornamental wrought bronze trimmings, may be bought for \$2.95 complete. Vestibule latch and trimmings to match, \$2.70.

The best lever front door locks with heavy plain cast bronze trimmings, cost about \$5.75. Complete vestibule latch and trimmings to match, \$4.00.

Cheapest cylinder escutcheon, front door lock with wrought bronze trimmings, \$5.25 complete; vestibule latch and trimmings to match, \$4.60.

Columbia or Harvard front door lock, best quality, with neat ornamental bronze trimmings, \$6.75; vestibule latch and trimmings to match, \$5.00.

Yale Paracentric front door lock, with plain bronze trimmings, \$7.80; vestibule latch and trimmings to match, \$7.00.

*Store Door Locks. Plain Front.*

Good three-lever store door lock with heavy figured bronze-plated latch, handles and plates, \$1.80; same with heavy bronze trimmings, \$3.50.

Cylinder escutcheon store door locks with heavy bronze latch and plates, from \$5.00 to \$6.80 a set; same with stop work in the lock, from \$7.00 to \$8.80.

Rebated front locks cost about 12 per cent. more than the plain front locks.

*Night Latches and Office Locks.*

The cheapest cylinder escutcheon rim night latch, japanned finish, costs about 80 cents.

Columbia rim night latch, japanned case, bronze bolt and turn knob, \$1.20; same in all bronze, \$1.65.

Yale rim night latch, No. 22, japanned case, 90 cents.

Yale Paracentric rim night latch (screwless), No. 42, case oxidized copper, bronze knob and cylinder, \$1.50.

Mortise night latches, all exposed parts bronze, Harvard or Columbia, about \$1.90; Yale Paracentric, No. 66, \$2.10.

Columbia master keyed office door latches, with automatic lock to latch, \$5.00.

Yale Paracentric mortise office latch, not master keyed, \$3.70; master keyed surety system, \$4.20; same with duplex master key system, \$4.25.

*Knobs, Roses and Escutcheons.*

The best jet knobs, with figured bronze roses and keyhole plates, or with  $1\frac{1}{2} \times 5\frac{1}{2}$ -inch escutcheon plates, cost about 35 cents per door.

Figured bronze knobs with  $1\frac{1}{2} \times 5\frac{1}{2}$ -inch escutcheon plates, cost about 60 cents per door, and common spun bronze knobs with plain wrought escutcheon plates, can be bought for the same price. A cheap, but rather pretty pressed knob and escutcheons in old copper, sand finish, can be bought for about 60 cents per door.

The Yale spun bronze knobs, natural finish, triplex spindle and  $5\frac{1}{2} \times 1\frac{1}{2}$ -inch escutcheon plates cost about 55 cents per door.

A plain flattened round knob (Fig. 396*B*), with a good rounded edge escutcheon plate can be bought for 90 cents per door in plain bronze or in iron Bower-Barffed. The same shape in Yale knob with triplex spindle (Fig. 396*A*), and  $6 \times 2\frac{1}{8}$ -inch beveled edge escutcheon plate costs \$1.40 per door\* in natural bronze.

The above figures are for  $2\frac{1}{4}$ -inch knobs, and escutcheon plates for  $3\frac{1}{2}$ -inch locks. Escutcheon plates for larger locks cost a little more.

Common glass knobs with bronze roses and keyhole plates cost about 75 cents per door, and a good wooden knob about the same price.

Yale cut glass knobs with bronze roses and keyhole plates, cost from \$2.85 to \$9.50 a door, according to amount of cutting.

*Bolts, Transom Lifters and Door Checks.*

Flush bolts, 12-inch, bronze metal front and bolt, 70 cents; 12-inch, bronze metal with lever, (Fig. 405), \$2.50; 12-inch, Stanley, bronze-plated (Fig. 406), 90 cents.

Extension bolts, bronze metal, T-handle, 24-inch, 85 cents; bronze metal with lever (Fig. 405), \$1.60; Stanley bronze-plated, with knob, 70 cents.

Chain and foot bolts for store doors cost about 50 cents each in cast iron, imitation bronze; 65 cents in japanned steel, and \$1.00 in bronze metal.

Transom lifters, 3 feet, coppered (not plated), 30 cents; bronze-plated, 45 cents; Bower-Barffed, \$1.25.

Pneumatic or liquid door checks with springs, for  $3 \times 7\frac{1}{2}$  feet by  $1\frac{3}{4}$ -inch door, cost about \$5.00.

*Window Trimmings.*

Sash fasts of the cam or Fitch pattern cost about 15 cents each in

\* This is the knob used as a base for the figures on Plate II.

iron; 18 cents in wrought bronze metal, and 25 to 30 cents in cast bronze, natural finish.

Ventilating sash bolts, bronze metal, cost about 25 cents each.

Sash lifts of the hook pattern, cost from  $3\frac{1}{2}$  to 10 cents each in bronze metal; a very good lift can be obtained for 8 cents. The hook sash lift and lock costs about 30 cents in bronze.

Flush sash lifts cost from 4 to 30 cents in plain bronze, the cheaper being of wrought metal.

Sash sockets, plain bronze, cost about 30 cents a dozen; a bronze-plated hook, 20 cents, and a solid bronze hook, 35 cents.

Window stop adjusters cost about 14 cents a dozen in blued steel, and 18 cents in plain solid bronze.

Sash adjusters, real bronze, 18 inches,  $\frac{3}{4}$ -inch round rod, \$1.50; lighter pattern, plated, 50 cents.

#### *Miscellaneous.*

Clothes hooks, wire, japanned, 12 cents a dozen; double, cast iron, japanned, 25 cents a dozen; cast bronze, \$1.75 to \$2.00 a dozen.

Coat and hat hooks, tall, plated, about \$2.00 a dozen; real bronze, about \$10.00 a dozen.

Letter plates for outside doors, Berlin bronze, 25 cents; solid bronze, 60 cents to \$1.00.

Cupboard catches, real bronze, flush, 30 cents; rim, 18 cents.

Cupboard turns,  $1\frac{3}{4}$ -inch, plated, 18 cents; real bronze, 30 cents;  $2\frac{1}{8}$ -inch, real bronze, 35 cents.

**252. Putting on and Superintendence.**—The putting on of the hardware, when applied to woodwork, should always be included in the carpenter's specifications.

To apply the hardware trimmings so that they will work properly, or the best that they are capable of, requires some skill and much care, and, as a rule, the better the hardware the greater care should be exercised in putting it on. The first hardware to be applied is usually the sash pulleys and the cords and weights. The only way in which the sashes can be properly balanced is by weighing each sash, which, although tedious, is necessary for a good job. The next in order are the butts and mortise locks. The putting on of the butts is apparently a simple matter, but it is one that requires considerable care to get them so that the weight of the door will be borne evenly by each butt (see Section 206), and so that the door will hang perfectly true. If one butt is set further out than the other, the door will not remain in its position when opened, but will either swing

back into the jamb or around against the wall. The mortise for locks should be cut of the exact size for the front, and so that the case will not bind in the door. The usual height for locks is from 2 feet 10 inches to 3 feet from the floor to the centre of the hub.

Sometimes it is necessary to vary this distance on account of the arrangement of panels. (See page 361.)

The balance of the trimmings should not be applied until the wood-work is finished, painted or varnished, as if put on before the painters or finishers are through, the exposed parts are quite sure to be daubed with paint or varnish, which cannot usually be removed without injury to the hardware. In putting on the escutcheon plates, care is required to place them so that the spindle and keyholes will be exactly opposite each other, otherwise the spindle and key will bind in the lock. The knobs should also be carefully adjusted, so that they will not slip back and forth through the lock. Swivel spindles require particular care in adjusting, for if the swivel does not come exactly at the centre of the lock, the knobs will not work properly. In putting on the striking plate for the lock, carpenters sometimes place them either a little too high or too low, so that the bolts or latch will not enter the holes provided for them. As the partitions are apt to settle more or less, the striking plates should be set so that the centres of the holes will be opposite the centres of the bolt and latch, thus affording a little play for settlement.

Sash fasts are also often carelessly set, so that they will not lock easily, or will not draw the sashes closely together.

All finishing hardware is now packed with screws finished to match. These screws are often rather small for the work required of them, and their holding power is often still further diminished by the carpenter driving them in with a hammer. This should not be permitted; every screw should be turned in its full length with a screw driver, and so that the head will fit neatly into the screw hole.

If the specifications are written on the second method, described in the next section, the superintendence will consist principally in seeing that the goods furnished are of the kind specified, and that they are properly put on.

Some hardware, notably the Yale goods, is stamped or marked so that the architect can tell the make at a glance, but a great deal of hardware can only be told (except by an expert) by the label on the box in which it is packed. This is especially true of plated goods, and of many makes of locks. It is very difficult to distinguish some plated hardware from solid bronze by merely looking at it, and plated

cast iron from plated steel. The superintendent should also remember that there are many imitations of the Bower-Barff finish.

Plated goods can be distinguished by scratching with a file on the back, but it is not so easy to tell plated cast iron from plated steel. The labels on the boxes, however, will usually be a sufficient guide.

Many manufacturers of tumbler locks make several grades, which cannot easily be distinguished from each other, except by examining the inside parts, so that the maker's name on a lock cannot always be taken as an indication of the quality.

Unfortunately most builders do not appreciate the importance of good hardware, and are apt to try to work in inferior articles.

When the doors are about to be hung, the superintendent should examine the doors, finish and specifications, to see that butts of proper size to enable the door to swing back (see Section 207), have been specified, and that the butts are of proper size for the weight and thickness of the door. If these points have been overlooked, they should be corrected before the butts are put on, even if a small "extra" is incurred.

Finally every door and window should be tried to see that they lock and swing perfectly, and that the sashes are properly balanced.

If the specifications make an allowance for certain portions of the hardware, the selection should be made by the architect or owner, preferably both together, and it is important that the architect shall have a pretty good idea of the actual cost of hardware, otherwise he may be imposed upon.

**253. Hardware Specifications.**—When artistic hardware of a high grade is to be used, and especially for large buildings, it is best not to include the hardware trimmings in the general contract, but to buy it direct from the manufacturers or dealers, selecting from samples. In this way the owner gets just what he wishes and with the least bother. In such case the carpenter's specifications should provide for putting on the hardware.

When it is not practicable to separate the hardware trimmings from the general contract, one of two methods may be used for specifying it.

The first, and one that is largely followed by architects, is to specify that the builder shall allow a certain amount of money for the door and window trimmings, exclusive of the cost of putting on, the architect or owner to have the privilege of selecting and ordering the hardware wherever he may choose, and the bill to be paid by the builder, to the amount of the allowance. This enables the architect

to put off selecting the hardware until the building is nearly ready for it, and gives the owner a chance to select the style of hardware he prefers. The allowance may be so much per door and window or in a lump sum, but the latter will usually prove the more satisfactory. The only objection to this method is that the architect, to be on the safe side, generally makes the allowance a little more than the hardware which he would specify would actually cost the builder, so that the owner usually pays a little more for his hardware by this method than he would by the other. Then also the trouble of selecting the hardware is often more than that of describing the goods to be used.

The amount of the allowance will of course depend upon the class of goods to be used, and the number of the doors and windows. In making up his estimate, the architect may be guided by the prices given in Section 251, for plain goods; for ornamental hardware he should get prices from a local dealer.

A form of specification by this method will be found in Chapter VIII.

The second method of specifying the hardware, and in the opinion of the author the best method, is to describe exactly what is wanted, and in the case of special styles or patterns the number of the piece in the manufacturer's catalogue, with the material and finish properly indicated, should be given. Locks should always be specified by name and number, as most manufacturers make several grades. This requires a little more knowledge of the subject than the other method, but except where elaborate trimmings are to be used it is generally the most satisfactory, and where the hardware can be specified in sets it is not as much trouble as to go to a store and pick it out. By this method the architect does not have to deal directly with the matter of cost, but has only to write his specifications so as to include all the hardware required and describe it clearly, and then see as the building progresses that it is furnished according to the specifications. A typical specification of this kind is also given in Chapter VIII.



## CHAPTER VII.

### HEAVY FRAMING.

---

The manner in which wooden floors for residences should be framed, has been described in Chapter II., and the floors in other classes of buildings are often framed and supported in the same way. The floors of stores, warehouses, mills, public buildings, etc., however, require as a rule, larger timbers, and should be supported by posts and girders rather than by partitions.

It is the purpose of the author in this chapter to describe some of the special forms of construction frequently required in buildings other than dwellings; the methods of framing with posts and girders, and what may be designated as "heavy framing."

**254. Bowled Floors.**—In modern Protestant churches it is becoming the custom to pitch the floor so that it will be higher at the back of the audience room than in front of the pulpit. For such floors the pitch should not exceed  $\frac{1}{2}$ -inch to the foot, as a greater inclination is unpleasant to walk over. If the seats are arranged in straight rows the floor should be merely an inclined plane, but if the seats are set on a circle the floor should be "bowled," so that any line drawn on the floor from the same centre that is used in laying out the pews will be *level* from end to end. Where chairs are used for seating a bowled floor is not absolutely necessary, but with pews it is quite essential. There are two methods of forming a bowled floor, their adoption depending principally upon the use that is made of the space below.

*First Method.*—If there is a finished story below the audience room, for Sunday school or similar purposes, it is generally necessary to frame the floor for a straight incline, and then form the upper or bowled surface by means of furring strips cut out of plank.

If the girders supporting the incline run the same way as the inclination they should be given the same pitch as the floor, and the joist will then be level from end to end. If the girders run in the opposite direction then they will be level endways, and the joist will be on an incline. Whether the joist or girders shall be inclined depends upon the plan of the room, the openings in the walls and the desired spacing of the columns. In arranging the girders it should

be remembered that it is better, and generally more economical, to give the *longer* span to the joist, and to limit the girder spans to 12 or 13 feet for wood and 16 feet for steel.

The greatest span that should be allowed for wooden floor joists in audience rooms may be found from the tables in Appendix B.

Joists 14 inches deep should not be less than  $2\frac{1}{2}$  inches thick, as

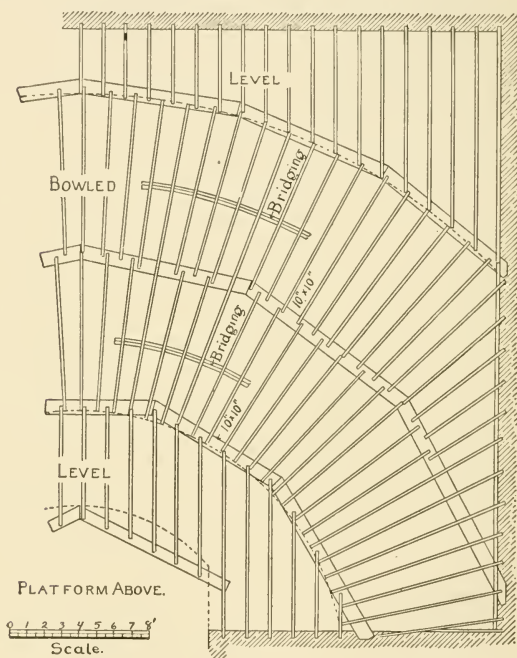

Fig. 457.

2-inch joists are apt to fail by buckling, unless bridged every 4 or 5 feet by *solid bridging*, and such bridging will usually cost more than the extra thickness in the joists.

The furring strips to form the bowled surface should be 2 inches thick, and may either be run across the top of the joists or spiked on top of them lengthwise. When the rise exceeds 8 inches, 2x6 joists may be used for the furring, and these should be supported every 3 feet from the main floor joists.



In the better class of theatres the construction of the balcony and galleries is usually entirely of steel. The following examples of gallery construction, taken from Mr. Birkmire's book, will serve to illustrate the usual method of framing. Fig. 458 shows the construction of the balconies in Abbey's Theatre, New York, Messrs. J. B. McElfatrick & Son, architects.

"For the support of the steppings in this theatre there are 8-inch steel channels extending from a line of 12-inch beam girders between the back columns to the inner circle lattice girders, and projecting nearly 10 feet beyond the girder. The channels are placed about 2 feet 6 inches apart and radiate toward the point from which the steppings are described.

"The steps are constructed of 1-inch yellow pine flooring upon

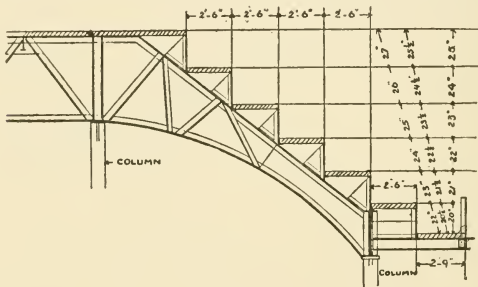

Fig. 459.

2-inch battens secured to stepping pieces of  $1\frac{1}{2} \times 1\frac{1}{2}$ -inch steel angles, bolted to the radiating channels.

"The risers are made of sheet iron about  $\frac{1}{16}$  of an inch thick and also secured to the angles."

The ceiling beneath was formed by bolting  $1\frac{1}{4} \times 1\frac{1}{4}$ -inch angles to the under side of the channels every 16 inches, and on these wire lathing was secured.

"The front of the balcony is constructed of 3 inch channel posts placed about 4 feet apart and secured to a continuous 6 inch channel extending around the entire front."

In the Empire Theatre, by the same architects, the steppings are supported by small lattice trusses (Fig. 459) which also radiate to the point from which the steppings are described. Between the trusses, and resting upon the bottom chord, Guastavino arches are con-

structed, making an excellent and practical fireproof ceiling, doing away with all furring and making desirable curves for the decorations.

“To support the flooring, which is of 2-inch boarding, knee pieces of plates and angles are secured to the top chord of each truss, as shown in the illustration. At the top of each knee piece 2-inch channels, and at the bottom 2-inch angles are secured, extending in a circle the entire length of the galleries.”

The risers, as in the previous example, are of plate iron.

Another favorite method of constructing these galleries is to use steel beams, placed about 4 feet 6 inches apart, and filled in between with fireproof arches of brick or hollow tile.

“This is no doubt the cheapest form, but the top and bottom of the beams are required to be bent to conform to the girders and step-pings of the tiers. If the girders supporting the lower ends of these beams are level the bending is an easy task, but when the front rakes 2 or 3 feet the beams become of different lengths, and then different bends are required. This construction is also considerably heavier than the Guastavino arch system and requires more metal in the beams and columns.”

**256. Church Galleries.**—*Wooden Construction.*—In churches there is usually but one gallery, and as the “sighting” is not as important as in a theatre, it is usually possible to regulate the width and height of the gallery (from the main floor) so that a 12 inch step will give the occupants a view of the pulpit platform and of a portion of the main floor.

Church galleries also generally have straight fronts, and if pitched lengthways the inclination is usually the same at the back and front, so that the supports remain of the same length. The construction must, as a rule, be of timber, as comparatively few churches can afford steel framing. Every architect, however, should endeavor to have the under side of the galleries protected by wire or some form of metal lathing, as this adds very little to the expense and would retard for a considerable time the destruction of the gallery by fire. There is also less danger of the plaster dropping from metal lathing than from wood laths.

When the conditions of the building will permit, the writer has found the method of gallery supports shown in Figs. 460 and 461 to be the most practical and economical.

The support is obtained by 10-inch or 12-inch joists, according to the span, which rest on a girder at the inner end and are built into

the wall at the outer end. Especial provision should be made to have the joists well tied to the wall, as otherwise the weight will have a tendency to push them inward, or the wall out. At least every other joist should be securely anchored. The wall end of the joists should also be notched, as shown at *S*, to give a horizontal bearing on the wall.

The steppings may be formed of 2x4's, supported by 1½-inch

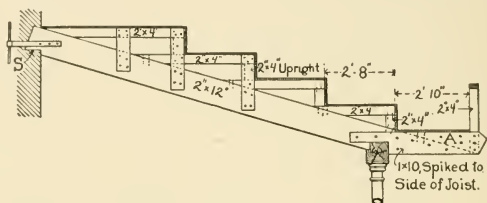

Fig. 460.

boards, spiked to each side and to the joist, or 2x4-inch uprights may be set under the ends of the horizontal pieces, as shown.

The projecting front, where it does not exceed 3 feet, may be framed by spiking a wedge-shaped piece of plank to the top of the joist, and then nailing a wide board to the side of both pieces. The rail, if of wood, is generally constructed of a framework of 2x4's ceiled on the inside and paneled and moulded as may be desired on

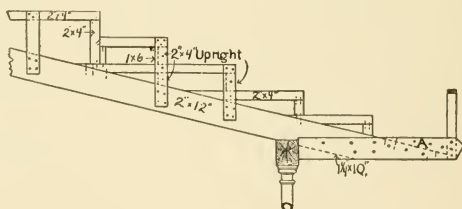

Fig. 461.

the outside, the top being covered with a wide cap piece. The uprights of the framework should be securely spiked to the side of the joist supporting the gallery.

In churches it is not desirable to have the solid portion of the railing exceed 2 feet in height on the inside, and 22 inches is better.

If a higher rail is desired an ornamental rail of 2-inch brass or steel tubing, with standards from 3 to 4 feet apart, may be placed on

top of the wooden rail, as this does not obstruct the view as a solid railing would.

If the projection of the gallery front beyond the line of the posts is between 3 and 6 feet, the floor may be supported as shown in Fig. 461. In this case it will be necessary to drop the upper end of the 12-inch joist, so that the inner end will come about as shown in the figure.

In order not to obstruct the view more than is necessary, the depth

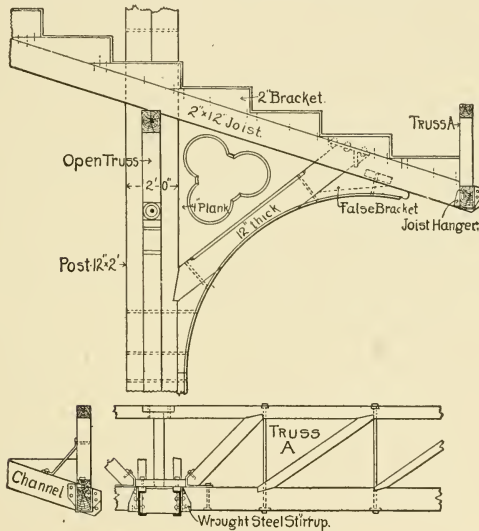

Fig. 462.

of the joist under the front step should not exceed 10 inches, and the girder should drop as little as possible, consistent with proper framing for the joists.

If the gallery is circular in plan the joists should radiate toward the centre from which the steppings are described, and the girder should be built of two steel channels bent to the proper curve and breaking joint over alternate supports.

**257. Galleries With Heavy Projection.**—In large assembly halls it is often desirable to project the front of the gallery 10 feet or

more beyond the line of posts. In such cases it will be necessary to support the front end of the gallery joists by a girder, which may itself be supported by a cantilever.

Fig. 462 shows approximately the framing of the lower gallery in the Mechanics' Hall in Boston. The large posts are placed about 25 feet apart and are carried up to support the roof trusses. On each side of the posts are placed heavy 12-inch iron channels (in line with the 2x12 joists) which are bolted to the post, and also supported by the bracket or brace shown in the drawing. The channels thus act as cantilevers, and support at their inner ends horizontal trusses, which in turn support the ends of the gallery joists. The other end of the joists rests on a partition under the gallery. The middle of the joists is supported by an ornamental open truss extending between the posts. Truss *A* is concealed in the gallery rail. This method of framing is applicable to many places where it is desired to use large posts placed from 20 to 25 feet apart, with a considerable projection to the gallery. Careful calculations of the various strains must be made, however, to insure safety.

In some cases galleries may be advantageously supported by means of trusses, similar to truss *A*, hung by rods from the roof trusses. When the depth does not exceed 16 feet the gallery may be supported in this way without posts.

**258. Framing of Stores and Warehouses.**—Although the larger stores and warehouses, particularly those in large cities, are now generally constructed with iron or steel posts and joists, yet the larger proportion of two and three-story business buildings, lodging houses, etc., are still built with wooden floors and partitions, and will probably continue to be for many years to come. Steel construction is undoubtedly preferable to wood in many ways, and when it can be employed and allow a fair return on the investment, the architect should certainly recommend it to the owner.

There are many ways, however, in which the ordinary wood construction, as found in the smaller cities and in country towns, may be greatly improved and made to answer its purposes nearly as well as steel construction.

One of the greatest defects in the ordinary construction of business blocks, small office buildings, etc., is *supporting the floors on wooden partitions*. No building other than a dwelling should have the floors supported in that way.

If the distance between the walls is not more than 24 feet the floor joists should be made of sufficient size to span from wall to wall



without assistance from partitions. If the distance between the walls is greater than 25 feet then brick partition walls, or posts and girders should be used for intermediate supports. For large rooms single spans of 28 feet may be used, but this is about the maximum span for which wooden joists can be used with economy.

The principal objections to the use of partitions for supporting the floor joists in this class of buildings are:

1st. Inconvenience in changing partitions. Business blocks in particular often require alterations in the partitions to suit the convenience of tenants, and when the partitions support the floors they cannot well be moved.

2d. The weight of the joists on the partitions has a tendency to spring the studding and loosen the plastering. The partitions themselves often have insufficient supports, and the ordinary 2-inch cap is too thin to support heavy floors. It will generally be found that where floors are supported on partitions that the plastering on the partitions is badly cracked and the ceiling sags at the centre of the partition.

3d. Less security in case of fire. Stud partitions, being constructed of small timbers, are quickly consumed by fire, and but a few moments are required to weaken the studding sufficiently to cause the floors to fall. Girders, on the contrary, being large, solid timbers, do not burn readily, and will often stand until the fire is extinguished.

*Posts and Girders.*—These should be arranged so that the span of the joists will not exceed 24 feet, and 16 feet gives greater economy. The girders may be of wood or steel; the former will generally be used except where girders of considerable length are required. With a joist span of 16 feet it is not good practice to have a greater span than 14 feet for the girders, and 12 feet is the maximum span permitted in several cities for wooden girders.

The posts may be either of wood, cast iron or steel. In buildings of not more than three stories, having wooden floor beams and girders, iron columns offer no particular advantage over wood, except that they may be made a little smaller. Metal posts, unprotected, will not stand as long in a fire as heavy wooden posts.

For the comparative advantages of cast iron and steel posts, and rules for determining their strength, the reader is referred to Chapter XI. of the *Architects' and Builders' Pocket Book*.

259. *Wooden Posts.*—The best timbers for wooden posts and girders are the long leaf yellow pine, Oregon pine and oak.

The posts may be either round or square. If round, it is better to leave the upper end square, as it gives a better bearing for the iron cap. The bottom of the post should be round if the post is turned.

It is generally considered that the durability of wooden posts is increased by boring a hole through the core or centre of the post.

The New England Mutual Insurance Companies, which insure nearly all the mills and factories of the New England States, advise that a  $1\frac{1}{2}$ -inch hole be bored through the centre of the wooden posts, with a  $\frac{1}{2}$ -inch cross hole near the top and bottom to give a circulation of air through the post. It is claimed that this precaution prevents decay and dry rot, but it is very seldom that posts are bored in ordinary buildings.

If bored, the boring should be done entirely from one end, and if the auger comes out more than  $\frac{3}{4}$  of an inch from the centre at the other end the post should be rejected. Boring from both ends is often done, but is not recommended, as it is difficult to make the holes meet at the centre.

All posts should rest on a cast iron plate, and *never* on a girder. The basement posts should rest on an iron plate bedded in Portland cement on top of a brick or stone pier, the top of the iron plate being kept a little above the concrete floor. The top of the posts should be fitted with an iron cap, which should support the girders and the post above.

Fig. 463 shows a tier of posts and girders for a two-story building.

The same construction is applicable for a five-story building by properly proportioning the size of the columns. The ends of the girders should be cut to fit closely around the bottom of the post, as shown at *X*, and be tied together longitudinally, either by bolting through the cap, as at *D*, or by iron straps, as at *C* and *X*. The bottom plate, *A*, should have a dowel in the centre to keep the post in position until the load is on.

The style of cap plate shown at *B* is the one most generally employed, and is about as good as any. When the girders and joist are in place, and especially when the building is occupied, there is no danger of the girders or posts slipping on the plate—in fact it would require a great force to move them—and the author doubts if any particular advantage is gained in fastening wooden columns together in a vertical line, for, if the building should take fire, the posts would certainly be destroyed as soon as the girders, and bolting the posts together top and bottom would in no way keep them from falling.

Many architects, however, prefer a cap with side plates like that

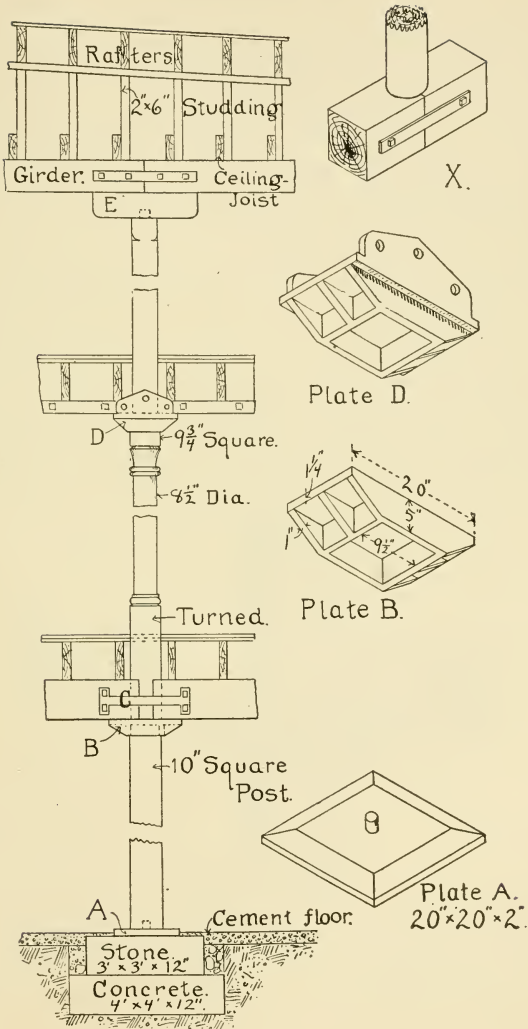

Fig. 463.

shown at *D*. The side plates add somewhat to the strength of the cap and keep the upper post and girder in place while the building is being erected. Holes may be left in the side plates for securing the ends of the girders and the post above.

Figs. 464 and 465 show the Goetz and Duvinage caps, which are similar to the cap shown at *D*. These caps have lugs or dowels cast on the bearing plate to hold the ends of the beams, and the Goetz cap is made so as to be bolted to the posts, the patentee claiming that this will keep the columns upright, even if the beams and girders fall. Both of these caps are well adapted for their purpose and are extensively used. They are patented, however, and cannot be used without paying a royalty to the patentees. Caps made like *D*, without the lugs for securing the girders, can be made at any foundry without infringing on the patents.

Fig. 466 shows a double post cap made entirely of forged steel.

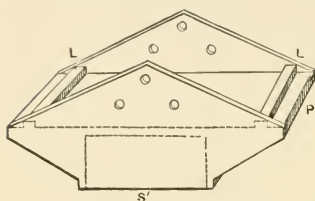

Fig. 464.—Goetz Cap.

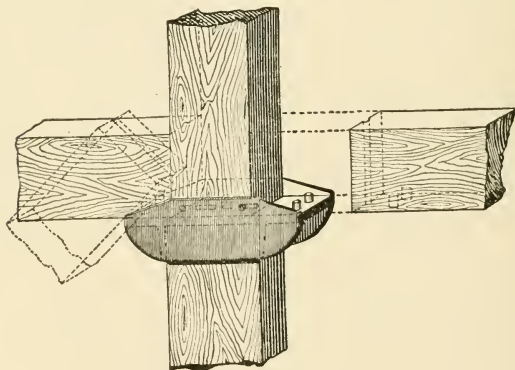

Fig. 465.—Duvinage Cap.

The side flanges, *F, F*, extend the full length of the cap, and the bracket bearing at *N* is riveted to the side flange and to the bottom ring. The post caps for girder in one direction only are made without the bearing *N*, as shown in Fig. 472.

The upper post may be capped by a wooden bolster (*E*) if preferred. The top of the post should be doweled into the under side of the bolster or secured by two square drift bolts, and the ends of the bolster should be spiked or bolted to the girder. The bolster should also be made of the hardest wood obtainable (preferably oak) so that the fibres will not be crushed where they bear on the top of the post. If the building has a flat roof, with a ceiling beneath, the ceiling joists should rest on a girder, and the rafters may be supported by a short partition of 2x6 studding, also resting on the girder.

The strength of wooden posts may be found from the tables given in the *Architects' and Builders' Pocket Book*, or from Appendix B.

Posts that are eccentrically loaded, *i. e.* from one side only, should have a greater cross section than if concentrically loaded.

The iron cap plates should be of such size that the girders will

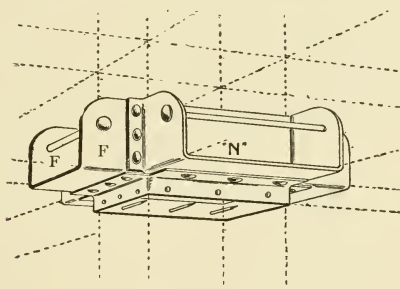

Fig. 466.—Van Dorn's Steel Post Cap.

have a bearing of at least 5 lineal inches at each end, and the edge of the plate should not project more than 6 inches beyond the post, unless absolutely necessary to get a sufficient bearing area.

The bearing *area* required for the end of the girder should be found by dividing one-half the load on the girder by 600 for oak, 500 for Georgia or Texas pine, 400 for Oregon pine and 250 for spruce. If the area thus found, divided by the width of the girder, is less than 5 inches, however, the latter distance should be taken as the minimum lineal support, except for very light girders.

*Example of Bearing Surface.*—A 10x12 Georgia pine girder is calculated to support 20,000 pounds. What bearing should it have at the ends?

*Answer.*—One half the load would be 10,000 pounds, and this divided by 500 gives 20 square inches for the bearing area. Dividing this by 10, the width of the girder, we have 2 inches as the distance

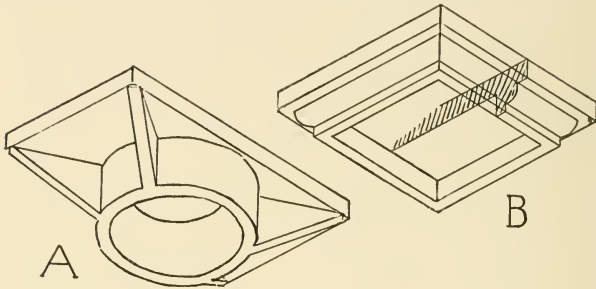

Fig. 467.

that the girder should rest on the plate; for practical reasons this should be increased to 5 inches.

Round posts are generally preferred to square posts, as they are less in the way, but there is necessarily a loss of strength in turning,

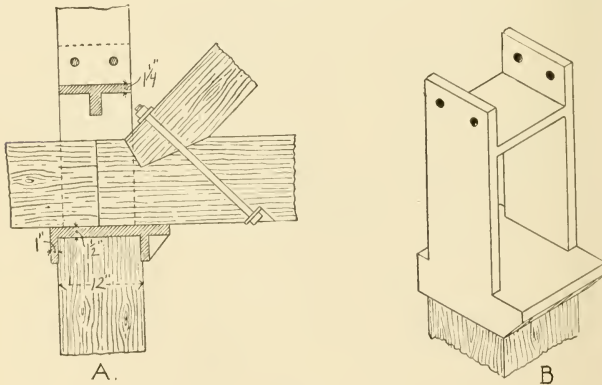

Fig. 468.

as the sectional area of the post is considerably diminished. For posts turned the whole length an iron cap like that shown at *A*, Fig. 467, may be used. The cap shown at *B*, is often used when the top of the post is left square and there is no post above.

Occasionally it is necessary to make the girders continuous over a post, or the post may support the end of a truss, in which case the post above cannot come down through the girder. For such construction a hollow cap plate should be used, something after the style of cap shown in Fig. 468. The cap should come down at least  $3\frac{1}{2}$  inches on the lower post, and should be bolted to the upper post.

*Proportions for Cap Plates.*—Rules for calculating the size of brackets, etc., for cast iron bearing plates are given in the later editions of the *Architects' and Builders' Pocket Book*. As a general rule the depth of the bracket should not be less than three-fourths of its projection.

The bearing plate should be  $1\frac{1}{4}$  or  $1\frac{1}{2}$  inches thick and the socket plates  $\frac{3}{4}$  or 1 inch thick.

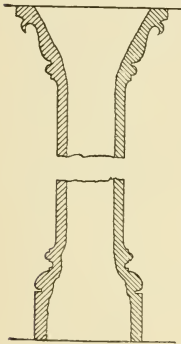

Fig 469.

The socket which encloses the top of the post should be made  $\frac{1}{2}$  inch smaller than the nominal size of the post, so that it will be sure to fit tightly over the post.

In designing iron castings the thickness of all the parts should be nearly uniform, that they may cool evenly and thus avoid initial strains.

Steel plates and caps being much stronger and not subject to internal strains need not be more than about one-half as thick, or even less.

**260. Cast Iron Posts.**—Cast iron posts are superior to wooden posts, in that they do not decay, can be made smaller than wooden posts, and are not damaged by wear and tear. They also give the appearance of greater strength and durability, although this appearance may often be deceptive. When not protected by fireproof materials they are quickly injured by fire and water, and in a fire will stand no longer, if as long, as wooden posts.

The shell of cast iron columns that carry any weight should not be less than  $\frac{3}{4}$ -inch thick, and should be cast straight from end to end; under no circumstances should a supporting column be cast as in Fig. 469. If the column is to be loaded with 60 per cent. of its calculated safe load, the thickness of the metal should be tested by boring one or more small holes through the shell and measuring the thickness of the opposite side by means of a stiff wire. A difference in thickness of more than  $\frac{1}{8}$  of an inch should not be permitted.

The ends of all posts should be turned in a lathe to a true plane at right angles to the axis of the columns. The lower post should rest on a cast iron plate with a raised cross cast on it to fit into the column. The portion of the plate which receives the column should also be turned. The upper posts should be bolted to those below. Fig. 470 shows the manner of casting the top of the columns where wooden girders are used. The top of the column should come about 4 inches above the top of the girder, unless the joists are framed flush, to facilitate bolting the columns together.

The ends of the girders should be tied together by straps on each side, as shown in Fig. 463.

If for any reason a very large cap plate or hollow box is required to support the floor construction, it may

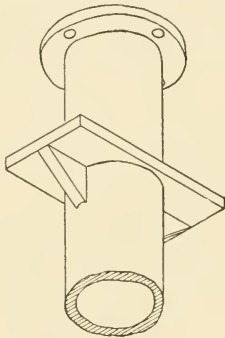

Fig. 470.

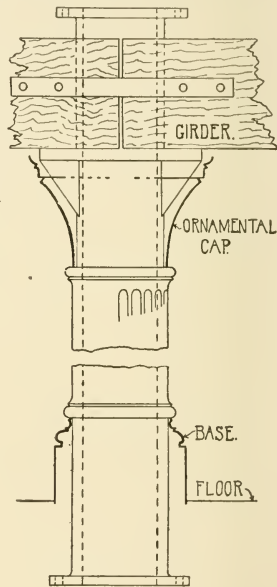

Fig. 471.

be cast separately and bolted to the top of a plain column, the bearing surfaces being turned to fit closely.

If an ornamental cap and heavy projecting base are desired below the girder, they should be cast in separate pieces and screwed to the columns, as in Fig. 471.

*Steam Pipe Columns.*—In many places a light, inexpensive column is required where only a slight load is to be supported. A particular demand for such columns is at the angles of show windows in one and two-story store buildings. As a rule, in such buildings the floor



Joists are supported by the side walls and the columns only have to support a light wall above. For such places steam pipe may be advantageously used for the columns, and also for the columns supporting the roof if one-story buildings or light floor loads. It should be borne in mind, however, that steam pipes have a very small sectional area, and they should be used for columns with extreme caution. Their length, in inches, should never exceed thirty times their diameter, if loaded with more than 50 per cent. of their safe load.

The ends of the columns should be turned perfectly true, and should be fitted with top and bottom plates like that shown in Fig. 472. These plates should also be turned where they bear against the column. Ornamental caps should be cast separate and screwed on. Where the columns carry less than 50 per cent. of their safe load, flange unions screwed to the pipe may be used for cap and base plates.

The safe loads for ordinary steam pipe columns may be determined by means of table V, Appendix B.

**261. Connection of Floor Joists and Girder.**—In buildings of ordinary construction, that is with floor joists 2 or 3 inches thick, it is customary to drop the girder so that the floor joists may rest on top of it, as shown for the first floor, Fig. 463. Very often the joists and girder are framed as shown for the second floor, a cross section of the girder being as in Fig. 52. In either case the joists should be tied together across the building by iron dogs (see Fig. 52) once in every 4 feet or by spiking the ends of the joists together.

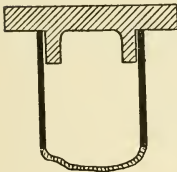

Fig. 472.

If strength and economy alone are to be considered, placing the joists on top of the girder is the most economical method, and as strong as any.

From a slow-burning standpoint, however, this is the worst kind of construction as it leaves a space above the girder around which flames can lap, and also affords a chance for the accumulation of dust and dirt which in the course of time adds inflammable matter for a fire to feed upon. With the joists framed *flush* with the girder on top, no spaces are left and the girder will be much longer in taking fire. The flush girder also gives a much better appearance to a room of moderate height.

When the beams are framed flush (in all buildings other than dwellings and small private stables) they should be supported either by steel or malleable iron joist hangers, or stirrups (see Sections 57

and 58), or by strips or angle irons bolted to the girder, as in Figs. 52, 53 and 55. Steel stirrups or hangers undoubtedly give the greatest strength, and if the ceiling is not plastered are to be preferred.

Fig. 472a shows the ideal method of framing of buildings of ordinary construction, although if the ceiling is to be plastered it would perhaps be best to use the Duplex or Goetz joist hangers, as they are not as much affected by shrinkage in the girder (see Section 57).

### 262. Bracing of Posts and Girders in Heavy Frame Structures.

—Buildings of several stories having the floors supported by posts and girders without partitions are not very rigid, hence if the building is very high, so as to be effected by wind pressure, or contains machinery, it is very desirable to brace the posts and girders at the angles formed by their intersection, as shown in Figs. 473 and 475. Such bracing also adds materially to the strength and stiffness of the girders, but not to the posts.

A very interesting paper by Prof. Edgar Kidwell, of the Michigan Mining School, entitled "Comparative Tests of Bracing for Wooden Bents," was published in Volume IV., of the Proceedings of the Lake Superior Mining Institute. From the tests therein described, Prof. Kidwell found that for wooden braces, the best

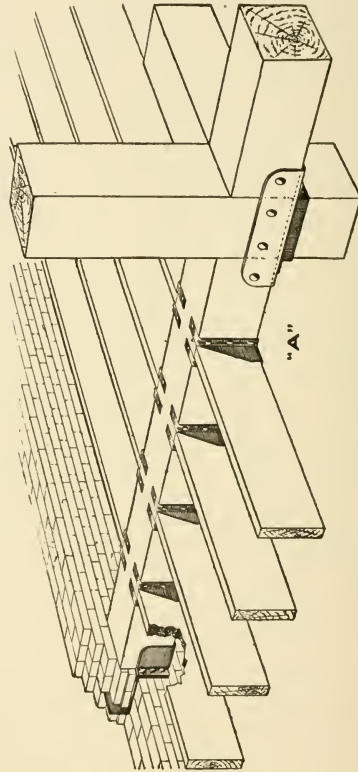

Fig. 472a.—Van Dorn Joist Hangers and Post Cap.

method of framing the brace to the post and girder, all things considered, is that shown in Fig. 473. Cast iron knees of the pattern shown in Fig. 474 were found to add little to the stiffness of the

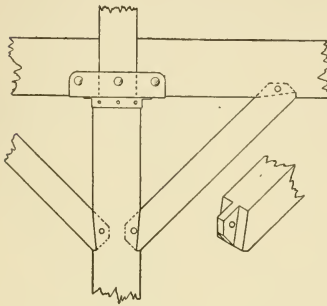

Fig. 473.

bent, until the latter had deflected more than would be admissible in a building. As a result of his studies and experiments on the bracing of wooden bents, Prof. Kidwell has patented the brace shown in Fig. 475, which consists of a piece of ordinary gas or steam pipe, fitted by right and left hand screw threads into cast iron shoes, designed to be secured to the posts and girders as shown. For structures containing very heavy machinery, the shoes should be secured by bolts (preferably passing outside of the post), but for stationary loads, lag screws may be used. The drawing shows the brace as applied in the top story, or where the girder passes over the post, but it is equally efficient when the girder rests on a post cap, as in Fig. 473, the ends of the girders, of course, being well tied together.

The obvious advantages of this brace over the wooden brace are greater rigidity of connection, less weakening of the post and girder, and opportunity for adjustment in case of shrinkage in post, or settlement of girder. Other advantages are that the brace can be applied at any time and to old as well as to new buildings; it is also less clumsy than the wooden brace.

The sizes of pipe to be substituted for various sizes of wooden braces are as follows:

For 4x4 brace, 2½-inch pipe; for 4x6 brace, 3-inch pipe; for 4x6 brace, 4-inch pipe; for 6x8 brace, 4½-inch pipe.

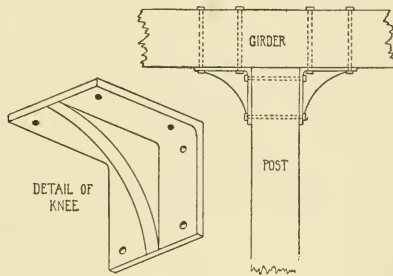

Fig. 474.

263. **Framing for Area Walls.**—Buildings having storerooms in the first story, and rooms or offices above, generally require an area on one or both sides to furnish light and ventilation for the inside rooms. As in such buildings the ground floor commands the greatest rental per square foot, it is essential to utilize the full area of the lot, and to do this it is necessary to start the light area at the

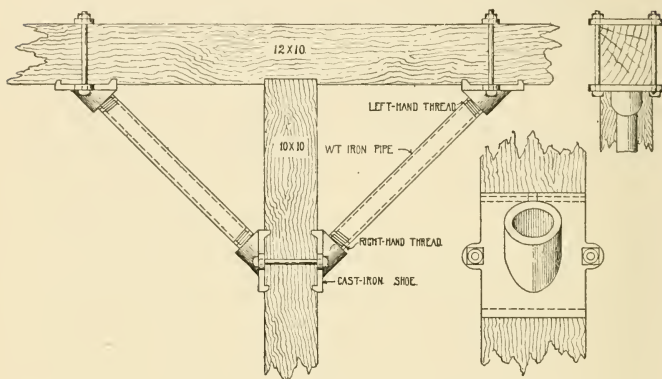

Fig. 475.

level of the second floor, the first story being lighted by a skylight, which forms the bottom of the area.

A very common arrangement of such buildings when erected on an inside lot is shown in Fig. 476, which is a plan of one side of the second floor, the stories above being divided in the same way. For



Fig. 476.

city buildings of the ordinary construction the area and party walls are usually of brick. As the area walls start from the second floor level they must, of course, be supported on girders of some kind. There are two methods of construction commonly employed in framing and supporting these girders. The cheapest method is that shown in Fig. 477. Girders of suitable size are placed directly under

the area walls, and are themselves supported by columns or posts spaced at economical distances, as shown in the figure. Constructionally this method is probably the best, as it economizes material and carries the loads more directly to the foundation, but the posts

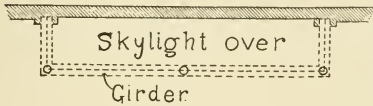

Fig. 477.

are usually considered as objectionable in a store, and are apt to decrease the rent. It is, therefore, generally desirable to frame the girders supporting the area so that

the columns may be omitted. The method of accomplishing this is shown in Fig. 478, which represents the framing of a portion of the second floor in a building 50 feet wide.

Girders *A, A, A* are placed crossways of the building and from 10 to 14 feet apart, the outer ends being supported on the first story wall and the inner ends on the columns which support the centre tier of girders.

The girders *A, A, A* support the girders *B, B*, which carry the wall above. The latter girders may either be framed between the former or may rest on top of them; in the latter case it will be necessary to drop the girders *A, A* below the ceiling line. It would probably be more economical to frame the girders flush and drop both beneath the ceiling, as in that case the floor joists would rest on top of the girder *B, B*. When the latter is flush with the ceiling the joists must be supported either on an angle bar riveted to the

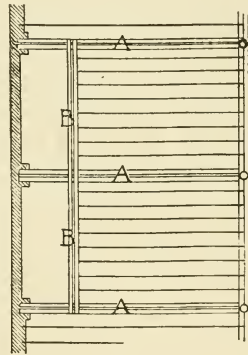

Fig. 478.

girder or be hung in some form of joist hanger. Keeping the girders *B, B* flush with the ceiling, however, obstructs the light from the skylight much less than when they are dropped. Fig. 479 shows a section through the bottom of the light area with the girders *B, B* flush with the ceiling.

In brick buildings over two stories in height the girders *A* and *B* should be made of steel beams, used in pairs; or, if these cannot be obtained of sufficient size, riveted box girders should be used.

The floor joists in the third and upper floors, and also the rafters, are supported by the area wall, hence the load on the girders *A* and

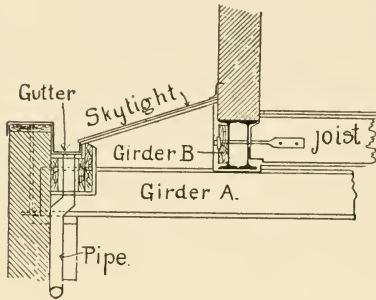

Fig. 479.

foot of span. If either of the girders are dropped beneath the ceiling they should be protected from fire by metal lathing or tile.

The load which the beams *A, A* transmit to the wall should also be carefully computed and a bearing plate of proper size placed under them. It will also probably be necessary to reinforce the wall by a pilaster, as shown in Figs 477 and 478.

If the side wall is a party wall, or comes close to the lot line, it will be necessary to convey the rain water through soil pipes placed inside the building and a gutter provided at the foot of the skylight to collect it. Fig. 479 shows the usual method of forming the gutter and finishing the wall.

*B* is very considerable and must be computed with great care. It must also be remembered that the girders *B, B* transmit a *concentrated* load to the girders *A, A*, and the size of the latter must be computed accordingly.

The depth of the girders should be such that the deflection shall not exceed  $\frac{1}{30}$  of an inch per

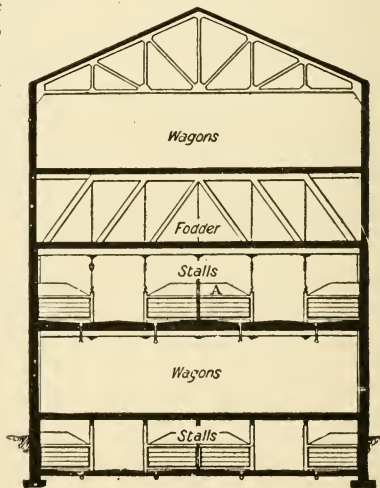

Fig. 480.

**264. Floors Supported by Rods and Trusses.**—In planning large stables and buildings containing assembly rooms, it is

very often necessary to provide for rooms in intermediate stories, 40 or 50 feet square, without posts or other vertical supports. If such

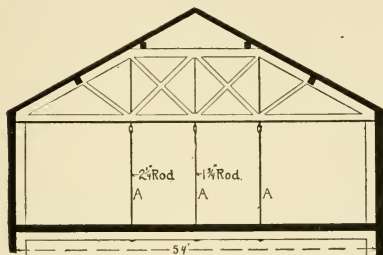

Fig. 481.

rooms are not more than 50 feet wide the floor above can be supported by riveted or trussed girders, but as the former are quite expensive and either must drop considerably below the ceiling, they are not generally practicable unless the story is a very high one.

The usual method of supporting the upper stories in such buildings is by means of trusses and suspension rods, as illustrated by Fig. 480\*, which represents a section through the American Express Company's stable on East Forty-eighth Street, New York City.

In this building the first and fourth stories are devoted to the storage of wagons, and are entirely free from posts or rods. The third and fourth floors are supported directly on the bottom and top chords of ordinary Howe trusses, and the second floor is hung from the trusses by rods. The roof over the upper story is supported by an independent truss.

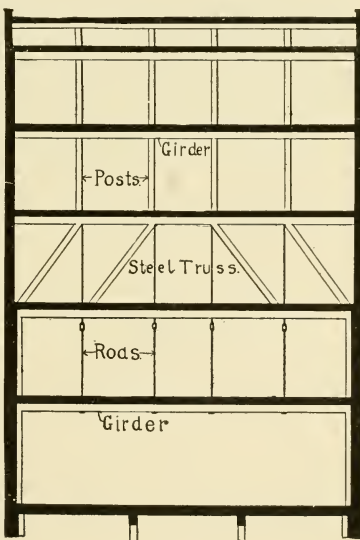

Fig. 482.

The truss being placed in the story used for the storing of fodder, interferes little with the convenient use of the space. The rods in the

\* From the *Engineering Record*, Vol. 31, No. 1, by permission.

story below pass through the stall posts and are thus entirely out of the way.

If only one floor above the open story is to be supported it may be hung directly from the roof truss, as shown in Fig. 481, which shows the method of supporting the floor over the auditorium in the Museum of Fine Arts, St. Louis, Mo. In this case the rods *A, A, A* are concealed in partitions. Where the arrangement of the stories will permit, it is undoubtedly better construction to support the second and third floors above the open story by means of a Howe truss, as in Fig. 482, and if there are additional floors above, these may be supported by posts, as shown in the same figure. Placing

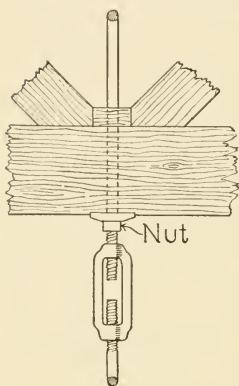

Fig. 483.

the truss near the bottom of the building lessens the weight borne by the walls above and also increases the stability of the building, as the truss acts also as a brace to stiffen the building against swaying sideways. Where trusses support several stories by means of posts they should always be of steel. When supporting floors by means of trusses it must be remembered that all the weight borne by them must be transferred to the walls, and the higher the truss is placed the more "top-heavy" the building will be and the greater will be the quantity of material required in the piers supporting the trusses.

It is always better, when the purpose of the building will permit, to support the floors on columns running through continuously from foundation to roof, and when an open story must be provided it should be placed as near the top of the building as the conditions will allow. There are numerous buildings, however, in which many stories are supported by trusses after the manner shown in Fig. 482, and several of the tallest buildings in New York have the wall columns for the entire height of the building supported on cantilever trusses resting on the foundation piers.

In the Crocker Building, San Francisco, seven stories are supported by trusses in a manner very similar to that shown in Fig. 482.

The Schiller Building, Chicago, has seven stories supported by trusses placed just over the theatre and carrying lines of columns.



As a rule, not more than one story should be hung by rods below the truss.

The manner of securing the suspending rod is also a matter of importance. The method shown in Fig. 483 is probably as good as any, and is comparatively simple. The truss rods are extended some 6 inches or more below the washer under the tie-beam, with a thread turned the full length. A nut is then screwed on and turned up until the truss timbers are brought tightly together, and then a turnbuckle is screwed on as shown. The turnbuckle can be made larger at the upper end than at the lower, to allow for the difference in size of the two rods. The truss rod, having to sustain the entire weight from the suspension rod, and also an additional strain from the truss timbers, should consequently be larger than the suspension rod.

If turnbuckles cannot be readily obtained, or the strain requires a very large truss rod, two rods may be substituted for the latter, coming down each side of the tie-beam as shown in Fig. 484, and the suspension rod passed through the tie-beam and washer, with a head or nut on the upper end as shown.

This method has the objection that the lower washer or plate must project considerably beyond the tie-beam, and the full load from the suspension rod and from the truss is also brought upon it.

*Galleries* or balconies are often hung from trusses by suspension rods in the manner described above, thus avoiding posts in the room below. Posts, however, are better, as they carry the load directly to the foundation, and by giving a rigid support to the gallery the latter also strengthens the wall. With rods, on the other hand, the weight of the gallery is transferred to the wall at a considerable distance above the floor, and the whole tendency of the construction is to spring the wall. Only those forms of trusses which have horizontal tie-beams should be used for suspending floors or galleries.

Fig. 485, which shows the manner in which the first floor, and also the sidewalk, is supported between the stone piers of the street front of the *Youth's Companion* Building, Boston, is interesting as a detail of this class of framing. The rod is suspended from a box girder at the second floor level, and terminates in the nut beneath the steel beam from which the sidewalk beam is hung. A short cast iron column is slipped over the rod, with its base resting on top of the

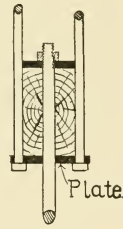

Fig 484.

I-beam, and supports the end of the first story trimmer or girder, the whole being borne by the nut on the end of the rod.

**265. Compound Wooden Girders.**—The girders in the class of buildings considered in this chapter will generally be of wood in the smaller towns and cities, and of steel in the larger cities.

The details of the simple wooden girder have already been considered, but it sometimes happens that it is necessary to use a girder of longer span than would be safe for the deepest single beam that can

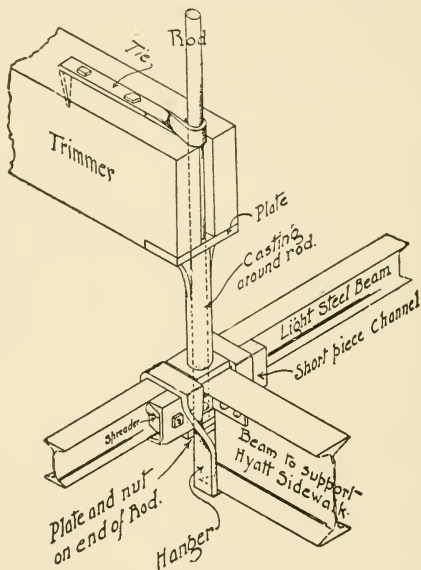

Fig. 485.

be obtained, and in such case, where steel beams cannot be obtained without great expense, compound wooden beams may be used.

By a compound wooden beam or girder, is meant a beam built up by placing two or more single beams, one *on top* of the other, with the view of having them act as a single beam having the depth of the combined beams.

This, if two 10-inch x 10-inch beams were placed one on top of the other, and the upper one loaded at the centre, the beams would act as

two separate beams (Fig. 486) and their combined strength would be no greater than if the two beams were placed side by side. If, however, the two beams can be joined so that the fibres of the lower beam will be extended as much as would be the case in a single beam of the same depth, or, in other words, so that the two beams will not slip on each other, the compound beam will have four times the strength of the single beam.

Various attempts have been made to join beams thus placed, so as to prevent the two parts slipping on each other, but until very recently there has been no experimental data to show how far such methods accomplish their object.



Fig. 486.

During the years 1896-7, however, Prof. Edgar Kidwell, of the Michigan College of Mines, made quite an extended series of tests of the efficiency of compound beams of different patterns, and from these tests much valuable data has been obtained. A full description of the tests accompanied by the conclusions of the author, and rules and data for proportioning the bolts and keys, of keyed beams, is published in Vol. XXVII., Transactions of the American Institute of Mining Engineers.

Probably the most common form of compound beam, as used in

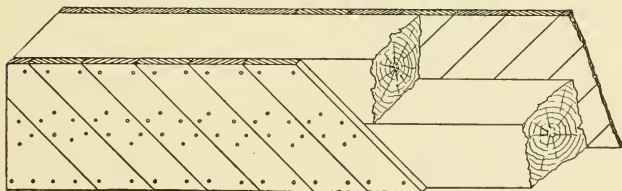

Fig. 487.

American building construction, is that shown in Fig. 487, diagonal boards in opposite directions, being nailed to each side of the two timbers to prevent their slipping on each other. Mr. T. M. Clark, in his *Building Superintendence*, advocates this as one of the best forms of compound beams, and places its efficiency at about 95 per cent. of a solid beam of the same depth.

Prof. Kidwell made nine tests of this style of beam, six having a ratio of span to depth of beam as 12 to 1, and three as 24 to 1. The

shorter beams gave an average efficiency without much variation, of 71.4 per cent., and the longer beams an efficiency of 80.7 per cent.

It was found that the beams failed by the splitting of the diagonal pieces or the drawing of the nails—"in every case, long before the beam broke, the struts split open or the nails were drawn partly out, or bent over in the wood, thereby permitting the component beams to slide on each other. It was found that no amount of nailing could prevent this."

When built with diagonal boards  $1\frac{1}{4}$  inches thick, nailed with rod's, as in Fig. 487, the working strength of such a beam may be taken at 65 per cent. of the strength of a solid beam of the same depth, and of a breadth equal to the breadth of the timbers. The deflection of the beam, however, will be about double that of a solid beam of the same size, and on that account this style of beam is not to be recommended for supporting floors with plastered ceilings or carrying plastered partitions.

**266. Keyed Beams.**—Prof. Kidwell also tested several styles of keyed beams, with the result that a compound beam keyed and bolted together, as shown in Fig. 488, was found to be the most efficient form that it is practicable to build.

It was found that with oak keys it was possible to obtain an efficiency for spruce beams of 95 per cent, while the deflection varied from 20 to 25 per cent. more than would be expected in a solid beam.

By using cast iron keys the deflection was found to be but little, if any more, than with a solid beam. The keys must be wedge-shaped, as shown in Fig. 489, so that they can be driven tightly against the end wood.

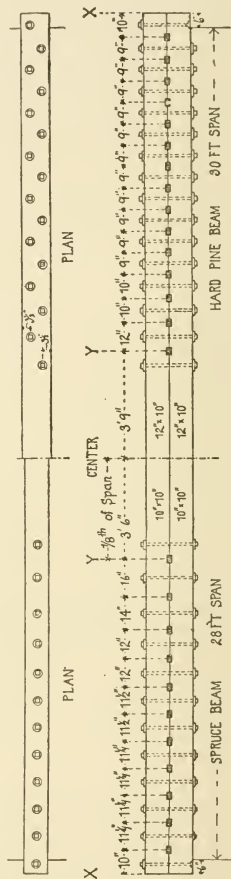

Fig. 488.—Compound Keyed Beam.

Prof. Kidwell recommends that for ordinary purposes an efficiency of 75 per cent. be allowed when oak keys are used and 80 per cent. when the keys are of cast iron. The width of oak keys should be twice the height of the key. Numerous small keys closely spaced gave better results than fewer large keys. In the centre of the span a space equal to about one-quarter of the length of the beam should be left free of keys, bolts, etc. In his report, Prof. Kidwell also gives formulas for the number and spacing of the keys.

As compound beams, if used, would probably be built of either 8, 10, 12 or 14-inch timbers, the author has prepared the following table giving the maximum safe load that may be allowed for keyed beams 16, 20, 24 and 28 inches in depth, put together as in Figs. 488 and 489, and also the number of keys required on each side of the centre.

## SAFE DISTRIBUTED LOADS IN POUNDS FOR COMPOUND KEYED BEAMS.

16 and 20-inch beams to have  $1\frac{1}{2} \times 3$ -inch oak keys,  $\frac{3}{4}$ -inch bolts, 3-inch washers.  
 24-inch beam to have  $2 \times 4$ -inch oak keys,  $\frac{3}{4}$ -inch bolts,  $3\frac{1}{2}$ -inch washers.  
 28-inch beam to have  $2\frac{1}{4} \times 4\frac{1}{2}$ -inch oak keys,  $\frac{3}{4}$ -inch bolts,  $3\frac{1}{2}$ -inch washers.

Size of Beam.	Span of Beam in Feet.						
	20	24	28	30	32	36	
1x16	{ White Pine . . . . .	1152	960	823	768	720	....
	{ Spruce . . . . .	1344	1120	960	896	840	....
	{ Oregon Pine . . . . .	....	1440	1234	1152	1080	....
	{ Georgia Pine . . . . .	....	1600	1371	1280	1200	....
1x20	{ White Pine . . . . .	1800	1500	1285	1200	1125	....
	{ Spruce . . . . .	....	1750	1500	1400	1312	....
	{ Oregon Pine . . . . .	....	2250	1928	1800	1687	1500
	{ Georgia Pine . . . . .	....	....	2142	2000	1875	1666
1x24	{ White Pine . . . . .	....	2160	1851	1728	1620	1440
	{ Spruce . . . . .	....	2520	2160	2016	1890	1680
	{ Oregon Pine . . . . .	....	....	2777	2592	2430	2160
	{ Georgia Pine . . . . .	....	....	3085	2880	2700	2400
1x28	{ White Pine . . . . .	....	....	2520	2352	2205	1960
	{ Spruce . . . . .	....	....	....	2744	2572	2286
	{ Oregon Pine . . . . .	....	....	....	3528	3307	2940
	{ Georgia Pine . . . . .	....	....	....	3920	3675	3266

To find safe loads for any given thickness of beam, multiply the load in the table by breadth of beam in inches.

For centre loads, take one-half those in table.

Beams should not be used for shorter or longer spans than those for which safe loads are given, except that 28-inch beams may be used up to 40 feet.

NUMBER OF OAK KEYS REQUIRED EACH SIDE OF CENTRE.

For Beams of	White Pine.	Spruce.	Oregon Pine.	Ga. Pine.
10-inch beams $1\frac{1}{2} \times 3$ -inch keys.	7	8	11	12
20- " " $1\frac{1}{2} \times 3$ - " "	9	11	13	15
24- " " $2 \times 4$ - " "	8	9	12	13
28- " " $2\frac{1}{2} \times 4\frac{1}{2}$ - " "	9	10	12	14
Minimum Spacing of Keys.				
$1\frac{1}{2} \times 3$ -inch keys. ....	$11\frac{1}{4}$ inches.	$11\frac{1}{4}$ inches.	9 inches.	9 inches.
$2 \times 4$ - " " .....	15 " "	15 " "	$11\frac{1}{2}$ " "	$11\frac{1}{2}$ " "
$2\frac{1}{2} \times 4\frac{1}{2}$ - " " .....	17 " "	17 " "	13 " "	13 " "

The breadth or thickness of compound beams should be not less than two-fifths of the depth. The number of keys required is *not affected* by the length or breadth of the beam, if the beam is figured for the full safe load.

In spacing the keys (Fig. 489) they should not be closer than the minimum spacing given in the table. For beams *loaded at the centre*, the spacing of the keys should be *uniform* from *X* to *Y*, *Y* being one-eighth of the span from the centre. If the distance between the

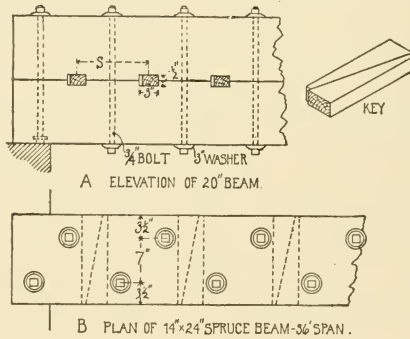

Fig. 489.

keys, centre to centre, works out less than the minimum spacing, the safe load should be correspondingly reduced or the thickness of the beam increased.

For beams uniformly loaded, the first four or five keys from the ends should be spaced for minimum spacing, and the spacing of the remaining keys increased toward the point *Y*. When the ratio of depth to span is greater than 1 to 16, the inner keys may be a little more than one-eighth of span from centre for distributed loads.

Fig. 488 shows the proper spacing for a 20-inch spruce beam of 28 feet span and for a Georgia pine beam of 30 feet span, and the following table gives the proper spacing for spruce beams (figured from the end of the beam) of longer span. For other woods and spans the spacing should be made as near like these as the fixed conditions will permit.

The sizes of bolts and washers to be used are given in the heading. If the beam is not over 10 inches wide the bolts may be arranged as for the spruce beam, Fig. 488; if 12 inches wide or over the bolts should be staggered as shown for the hard pine beam. In a very wide beam the bolts might be spaced as in detail *B*, Fig. 489.

Spacing of keys in inches (commencing at end) for distributed load:

16-inch Spruce Beam, 32 feet span.	10, 12, 12, 16, 19, 24, 32.
20- " " " 32 "	10, 11½, 11½, 11½, 12, 12, 12, 13, 15, 18, 24.
24- " " " 36 "	13, 15, 15, 15, 15, 16, 18, 20, 30.
28- " " " 36 "	15, 17, 17, 17, 17, 17, 17, 17, 17, 17.

**267. Trussed Girders.**—While compound beams may be advantageously used under certain conditions, it will generally be fully as economical and much better where there is sufficient height, to use a trussed girder of one of the types described below, and when the span exceeds 30 feet these are generally the only kind of wooden girders that will afford the necessary strength.

The most common method of trussing wooden girders is by the use of a "belly-rod," as shown in Figs. 490 and 491.

Such girders, however, are often very carelessly used and without any consideration of the manner in which the pieces are strained.

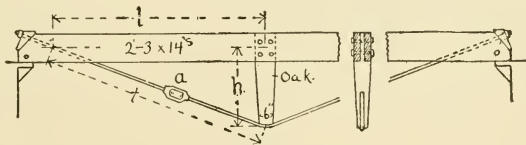

Fig. 490.

The most common fault found in such girders is that the rod is not large enough, and is not placed at a sufficient depth below the girder.

The author has seen a pair of beams trussed with a belly-rod where the rod did not go below the bottom of the beams, and very often but a little below. Now all solid wooden beams, with the possible exception of oak beams, generally commence to fail by the crushing

of the upper fibres, showing that the tensile strength of the wood is greater than its crushing strength, hence any addition to its tensile strength is superfluous unless the upper fibres are also strengthened. A truss rod, placed within the depth of a long beam, may make it stiffer, but cannot materially increase its strength.

The proper use of a belly-rod requires such a relation of depth,  $h$ ,



Fig. 491.

to span that the beam will only have to resist the crushing stress on the girder, while the rod sustains all of the tensile stress.

Rules for determining the stresses in belly-rod trusses are given in the *Architects' and Builders' Pocket Book* and other handbooks. In general the strain on the tie-rod is in the proportion of the length  $t$  to the height  $h$  (Fig. 490). The nearer the distance  $h$  approaches that of  $t$ , the less will be the strain on the rod. The distances  $l$ ,  $h$  and  $t$  should be measured from the centre lines of the pieces.

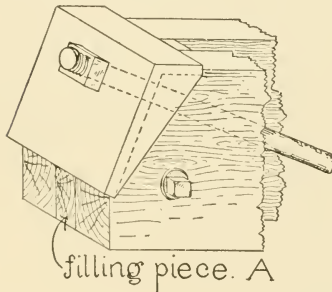

Fig. 492.



The best method of constructing a short belly-rod truss is that shown in Fig. 490. The beam is made of two timbers, spaced about 2 inches apart, or far enough to allow the rod to go between them. A cast iron plate, of which a larger view is shown at *A*, Fig. 492, should be placed over the ends of the beams to hold the nut or head of the rod. The strut, if made of wood, should be cut out of a large timber and tapered as shown, and a tenon should be cut on the upper



end to go between the beams. This tenon should be secured by bolts passing through the beams. Only oak or selected hard pine should be used for making this piece.

Iron struts look neater, as they may be made much lighter in appearance. If iron struts are used they should be made of the shape shown at *B*, Fig. 492. The rod should be bent to the correct angle before it is put in place, and should have a nut at each end, unless a sleeve nut is provided, so that the rod may be tightened without drawing over the end of the strut. At least one sleeve nut is desirable, although not absolutely necessary, to facilitate tightening the rod, should any settlement take place through shrinkage of the timber. If the stress in the rod is found to be greater than 24,000 pounds it will be better and more economical to use two rods instead of one. When two rods are used the beam should be divided into three pieces, so as to leave two spaces for the rods. For trusses of over 20 feet span two struts should be used, as shown in Fig. 491.

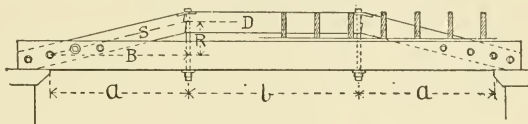

Fig 493.

By using two struts the stress in both the beam and tie are materially reduced, provided the same depth is given to the truss.

In computing the size of the beam it should be remembered that this acts both as a strut and as a simple beam. The span for the beam, however, is only from the bearing to the strut, or between the struts if two are used, as the strut divides the beam into two or three beams and transmits the load to the rod.

When girders are trussed in this way the joists must either rest on top of the girder or be hung in stirrup irons or joist hangers. In the so-called "mill construction" the floor joists are sometimes made of a pair of beams placed from 6 to 8 feet on centres and trussed with a belly-rod, the flooring being made of 3-inch plank.

268. When it is desirable that the girder shall project as little as possible below the ceiling, the form of trussed girder shown in Fig. 493 may be used to advantage. A cross section through this girder, to a larger scale, is shown in Fig. 494. This is an economical method of trussing, as only short rods and bolts are used, which can

be made in almost any village. The top of the truss may also be kept flush with the floor joist, and a good bearing for the latter still be afforded.

The principal points to be kept in mind in designing such a truss are to get as much depth as possible and full strength in the joints. It should be remembered that the depth and length of the pieces of any truss are measured from the centre lines of the pieces. In order to get the full benefit from trussing, the pieces *S* and *B* must be joined in such a way that the full horizontal component of the thrust in the piece *S* shall be transmitted to the beam *B*, and neither timber be materially weakened. This is best accomplished by making the beam *B* in two pieces, as shown in Fig. 494, and letting the strut *S* pass between them. The three pieces should then be well bolted together.

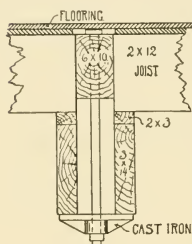

Fig. 494.

The rods transmit only a direct load, and are not usually very large. They must be provided, however, with a heavy cast iron plate or washer at the bottom, to support the beams, and either a cast, or wrought, iron bent plate washer at the top.

The girder shown in Fig. 493 was drawn for a clear span of 18 feet. The total depth of the girder was limited to 28 inches—12 inches for the joists, 14 inches for the beam *B*, and a 2x4 joist between them. The depth of *D* was taken at 10 inches, which gave 16 inches for the height *R*. The length of *S* and *B* by measurement (on centre lines) was found to be 68 and 66 inches, respectively.

To illustrate the method of calculating such a girder, we will perform the calculations for the girder shown in Figs. 493 and 494.

To start with we have the following

## DATA:

$A = 5$  feet 6 inches,  $b = 7$  feet, span = 18 feet.

$R = 16$  inches,  $S = 68$  inches,  $B = 66$  inches.

Distance between centres of girders, 16 feet. Total weight of floor and load, 125 pounds per square foot.

Total load on girder =  $W = 18 \times 16 \times 125 = 36,000$  pounds.

Load on each rod =  $\frac{3}{8} * W = 13,500$  pounds.

\* NOTE.—This fraction should only be used when the distance  $b$  is not more than one foot over one-third of the span.

Compression in  $S = \frac{3}{8} W \times \frac{\text{length of } S}{\text{length of } R} = 13,500 \times \frac{68}{16} = 57,375$  pounds.

Tension in  $B$  or compression in  $D = \frac{3}{8} W \times \frac{\text{length of } B}{\text{length of } R} = 13,500 \times \frac{66}{16} = 55,687$  pounds.

Timber, Georgia pine—safe crushing strength, 1,000 pounds per square inch; safe tensile strength = 2,000 pounds per square inch.

Sectional area of strut  $S = 57,375 \div 1,000 = 57.375$  square inches. As the depth was taken at 10 inches, the breadth must be 6 inches.

Sectional area of beam  $B = 55,687 \div 2,000 = 27.8435$  square inches = 2x14 inches, or 1x14 for each side.

The beam  $B$ , however, also has to support the ends of the floor joists, and must therefore have sufficient transverse strength for this purpose, *in addition* to the 28 square inches of section above found.

In this case the greatest span of the tie-beam is at  $b = 7$  feet. The load on each half of the beam for this span will be  $7' \times 8' \times 125$  pounds = 7,000 pounds.

From some handbook we find that a 1x14 inch Georgia pine beam, 7 feet span, will support 5,600 pounds, consequently a 2x14-inch beam on each side will be sufficient to support the transverse load, and a 3x14-inch beam will support both the transverse load and tension in truss.

As the load on each rod is 13,500, we find from a table that we must use a  $1\frac{3}{8}$ -inch rod. By having the screw end of the rod upset we might use a  $1\frac{1}{4}$ -inch rod, but the cost of upsetting would be greater than the additional cost of the larger rod, and only in the larger cities is there machinery for doing this class of work.

The outward thrust or kick of the piece  $S$  will be equal to the tension in  $B$ , = 55,687 pounds. If we connect the pieces by bolts they will be in double shear, and must be figured for a bearing of 6 inches  $\times$  the diameter of the bolt. We may allow a pressure of the bolt against the wood of 1,600 pounds per square inch for Georgia pine or oak. This would give us a resistance of 14,400 pounds for a  $1\frac{1}{2}$ -inch bolt. The resistance of the bolt to shearing (double shear) may be taken at 26,500 pounds, hence the number of bolts to be used will be determined by the bearing resistance. As the stress is 55,787 pounds and the bearing resistance 14,400 pounds per bolt, four  $1\frac{1}{2}$ -inch bolts will be needed. The joints of all trusses should be carefully calculated in this way.

When designing buildings to be erected in small cities, at a distance from the centres of manufacture, the architect should always figure on using such material as can be readily obtained, if such can be made to answer. For this reason in figuring the size of rods, it is better not to allow more than 10,000 pounds to the square inch, as it will be difficult to get the class of rods that are used in engineering works, and for which greater strength may be allowed.

#### MILL CONSTRUCTION.

269. Within the past sixteen years it has become quite common to frame the floors of mercantile buildings, and sometimes of office buildings, after the method known as *Mill Construction* and sometimes called "slow burning" construction. While "mill construction" should be slow burning, it differs widely from "slow burning construction" as now defined in Building Ordinances.

Mill construction applies only to those buildings in which no small timbers are used, and in which the floor beams and girders have a sectional area of at least 72 square inches and the posts (if of wood) a sectional area of at least 100 square inches, while in slow burning construction, floor joists 2 and 3 inches thick are used, and the "slow burning" is obtained by protecting all woodwork with metal lath and plaster, or plaster boards, and placing fire stops wherever practicable. The actual construction of the floor required by Building Ordinances for "slow burning" buildings is the same as for the ordinary construction described in Sections 258-260, although ordinary wood partitions or wood furrings of all kinds are not permitted.

The essential features of mill construction, as regards its resistance to taking fire and retarding the progress of flames, and also in preventing the building from being totally destroyed in case a fire gets under headway, are, that all wooden construction shall be of *large dimensions* and so arranged that there will be no spaces for flames to pass through, and no opportunity for dirt and dust to collect. The under flooring should be of plank and the floor beams and girders should be self-releasing from the walls; the posts should not depend entirely upon the beams and girders to keep them in position. No furring of any kind (except metal furring for plastering on planks or solid timbers) should be used in the building, and all partitions should be of planks, tongued and grooved together, or of incombustible materials.

Large timbers and thick flooring are slow to take fire and also burn very slowly. The avoidance of air spaces greatly retards spread-

ing of the fire, and enables the firemen to direct a stream of water against all parts of the burning construction.

Mill construction, as the term signifies, was first used in the construction of the large woolen and cotten mills of New England, and it is the only form of construction that can be insured in the Mutual insurance companies, which carry practically all of the insurance on those mills.

Fig. 495 shows the manner in which the floors are constructed and supported in mills built on this principle.

The posts are spaced 8 feet apart endways of the building and 24 or 25 feet the other way. There are no longitudinal girders, the floor beams, which are usually 12x14 hard pine timbers, resting on

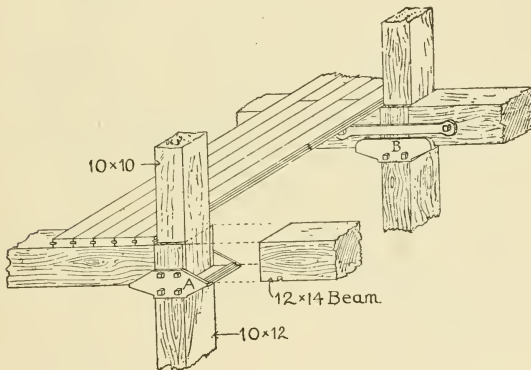

Fig. 495.

the post caps as shown. The floor on top of the beams is constructed, first, of 3-inch planks, not over 9 inches wide, planed both sides and grooved on both edges. The grooves are filled by strips of hard pine, called *splines*, about  $\frac{3}{4}$  of an inch by  $1\frac{1}{2}$  inches. The splines take the place of the tongue in matched boarding.

In nailing the planks it is better to blind nail them, after the manner of nailing matched flooring in dwellings, as this allows the planks to shrink or swell without cracking and without splitting the splines.

The upper flooring is generally of some hard wood,  $1\frac{1}{4}$  inches thick, merely jointed. Between the plank and the finished flooring a layer of mortar about  $\frac{3}{4}$  of an inch thick is generally spread. "The layer of mortar preserves the lumber from decay, prevents the floor

from becoming soaked with oil, and is so slow-burning that it is more nearly fireproof than any other practical method of construction."<sup>\*</sup>

In the original mill construction the posts were usually made round and tapered, and the posts in the upper stories, instead of resting on the cap of the post below, either rested on the girder or on a cross-shaped pintle cut in between the ends of the girders. These methods have now given place to the square post with chamfered corners and large bearing plates, as shown in the figure. The cap shown at *A* is the Goetz cap; that shown at *B* is not patented.

Other forms of post caps are shown in Figs. 465, 466 and 472.

The roofs of these mills are generally flat, and are framed in the

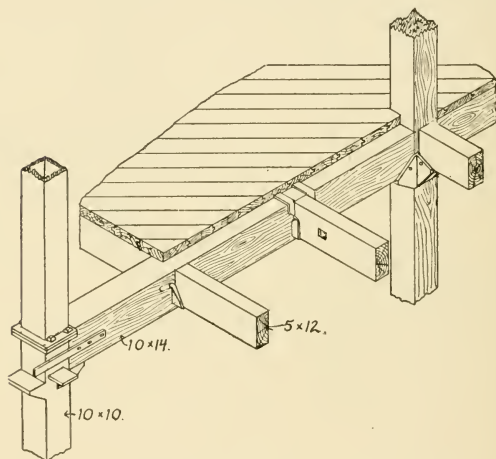

Fig. 496.

same way as the floors, but with lighter timbers and  $2\frac{1}{2}$ -inch roofing plank.

270. In applying this principle of construction to stores and office buildings, it is necessary to deviate considerably from the original mill method of framing.

In stores it is desirable to have as few posts as possible, which necessitates longitudinal girders and very often iron posts. In office buildings it is generally practicable to locate the posts so that they

<sup>\*</sup> "Fire Protection of Mills," by C. J. H. Woodbury, p. 163.

will come in the partitions, and as the rooms or offices are generally about 12 or 14 feet wide, the method of framing usually adopted is that shown in Fig. 496. When the posts are placed over 8 feet apart, so as to necessitate a longitudinal girder, it is more economical to space the floor beams about 4 feet from centres, as this permits the use of 2-inch planks for the under floor.

If the building is several stories in height it will also be necessary to use iron or steel posts, as wooden posts would take up too much room. If the posts come in partitions or are to be fireproofed, the square section makes the best shape for a cast iron post. Fig. 496

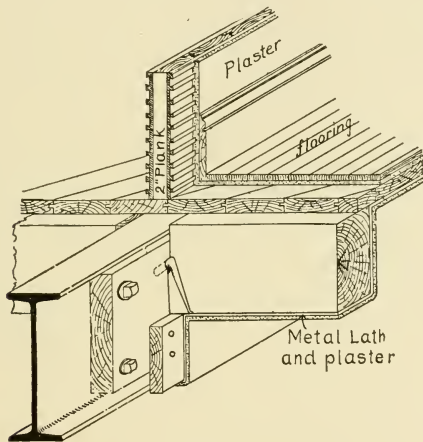

Fig. 497.

shows the manner of casting the bearing plates and arranging the end connections.

Iron posts should always be protected by fireproof materials, as they will not stand as long as wooden posts in a fire.

If the building is not more than three stories high, wooden posts with iron plates can generally be used.

The floor beams and girder should *always* be flush on top, and the former should be hung to the latter either by stirrup irons or joist hangers, with joint bolts on at least every other beam.

The under flooring, if of 2-inch spruce planks, will be cheaper tongued and grooved than splined. It is also better to lay the floor-

ing diagonally, as this stiffens the building and gives a better surface on which to lay the finished flooring, which should run at right angles to the beams.

A layer of mortar or of some fireproof lining, such as "Salamander," should always be placed between the plank and flooring in all first-class buildings.

When the span of the longitudinal girders does not exceed 14 feet it will generally be practicable to make them of wood, but when the span is 16 feet or more, steel beams should be used. In this form of construction it will probably be better to bolt 3-inch planks to the sides of the steel beams and hang the floor beams in joist hangers, as shown in Fig. 497. The girder should then be covered with metal lath and plaster. As it is practically impossible to give a neat finish to the under side of mill floors without casing or plastering, it is gen-

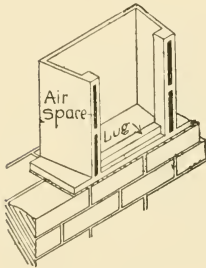

Fig. 498.

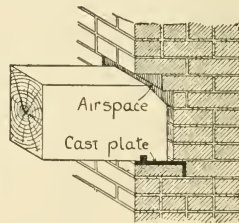

Fig. 499.

erally customary, when this method of construction is used in office buildings, apartment houses, etc., to cover the beams and under side of the planking with metal lathing and plaster. By taking a little pains in spacing the floor beams the ceilings of the various rooms can usually be divided into panels of equal size, which when plastered and tinted, give a very neat appearance.

The details of the floor and roof framing in this form of construction are usually quite simple, the construction shown in Fig. 497 applying to the whole floor.

In calculating the longitudinal girders the loads should not be assumed as distributed, but as concentrated at the points where the floor beams are supported. Formulæ for such conditions of loading are given in the *Architects' and Builders' Pocket Book*.

Where the beams and girders rest on the columns they should be



connected endways, either by notching the ends of the beams over the lug cast on the Goetz cap, or by bolts or wrought iron straps. It is also desirable to have the columns bolted together endways, as shown in the figures.

The method of anchoring and supporting the wall end of the beams and girders requires more consideration in this method of construction than in the ordinary method, as, the beams being larger, they make a greater hole in the wall, bring a greater crushing weight on the bricks, and have a more severe effect on the wall when falling.

The writer believes that the Goetz Box Anchor, shown in Fig. 498, makes probably the best anchor and support for large beams or girders built into the wall, as it provides a sufficient bearing plate, supports the wall above the beam, provides for free circulation of air around the beam, and readily releases the beam in case of fire. The Duplex and Van Dorn Wall Hangers accomplish the same purpose, although the beams are not so well tied to the wall, as only spikes should be used for securing to the hanger, otherwise the falling timber will pull the wall with it. The method of supporting the wall ends of the beams in the original mill construction is shown in Fig. 499. The bricks were carefully built around the end of the beam so as to leave an air space and plenty of room for the beam to fall out without injuring the wall. This method is not patented. Over beams exceeding 12 inches in thickness it would be well to place a flat stone or iron plate to support the wall above the beam end. In no case should the brickwork be built directly on top of the wood.

**271. Roofs.**—As before stated, the ordinary mill roof is usually flat, *i. e.* with a pitch of about  $\frac{1}{2}$  inch to the foot, and is framed in precisely the same way as the floors, the under side of the roof forming the ceiling of the upper story.

This form of roof may also be used for warehouses, but for buildings that are to be constantly occupied, as office buildings, hotels, etc., it will be necessary to provide a ceiling below the roof, to prevent the rooms in the upper story becoming too hot. The space between the ceiling and the roof should not be less than 4 feet at the lowest point, and should be ventilated by openings in the side wall.

**Pitch Roofs.**—Mill construction may also be used to advantage in constructing pitch roofs over churches, and wherever the attic is to be finished. Fig. 500 shows a section through the eaves of a church roof constructed on this principle.

The rafters are made of heavy timbers spaced from 5 to 6 feet apart, and covered with 2-inch matched planks. On top of the

planks should be spread a layer of lime mortar, about  $\frac{3}{4}$  of an inch thick, which may be kept in place by horizontal strips,  $\frac{3}{4} \times 1\frac{1}{2}$  inches, nailed to the planking about every 2 feet. Over the plaster, shingles, slate or tile may be laid in the usual manner. The layer of plaster would delay the roof catching fire from the outside, and also reduce the transmission of heat. The under side of the roof planking should be furred with  $\frac{3}{8}$ -inch strips, and then lathed and plastered. Metal lath would of course be best. Sheathing lath may also be used.

On this coat of plaster diagonal ceiling may then be placed, if a

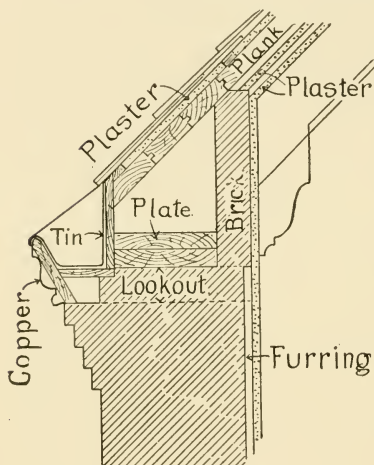

Fig. 500.

wood finish is desired, or it may be again furred, lathed and plastered. The two thicknesses of lath and plaster, with a  $\frac{1}{2}$ -inch air space between, would undoubtedly make the room beneath much warmer in winter and cooler in summer. If the roof span is over 25 feet wide, every third pair of rafters must be trussed, and purlins hung under the middle of the other rafters.

**Partitions.**—When mill construction is used for the floors and roof the partitions, unless of brick, should also be made of

solid timber, without air spaces, or else of  $1\frac{1}{2}$ -inch I beams, and metal lathing and plaster. Fig. 497 shows a wooden partition, made of 2-inch planks, covered with the Byrkit-Hall Sheathing Lath. This lath adds much to the stiffness of the partition, and under fire would probably hold the plaster as long as the rest of the construction would stand.

Mill construction, when intelligently carried out, undoubtedly ranks next to steel construction in durability and fire resistance, and far surpasses unprotected iron or steel in withstanding a fire. It has been found, however, that where tall buildings are constructed on this principle, if a fire once gets under headway, it is almost impos-

sible to save the building, the advantages of this method of building being more pronounced in buildings of not more than three stories.

The Chicago Building Ordinance permits the use of mill construction for office buildings, stores and warehouses between 60 and 100 feet in height, while the use of ordinary construction is limited to buildings under 60 feet in height.

### NEW PATENT JOIST HANGERS.

(Added to fourth edition.)

Since the first edition of this book was written, there has been placed on the market a new hanger, known as Lane's Patent Hanger, and of which three styles are shown by Figs. A, B and C. Other styles are made for use under special conditions.

These hangers are made of plate steel of uniform width and thickness throughout. They fit close against both the joist and header, and can be placed in buildings already built where tenons have weakened or settled.

The hooks are broad and afford a liberal bearing upon the top of the header, or upon the wall, and the seat for the joist is ample.

The strength of these hangers is calculated to be ample for the safe load allowed for yellow pine joists from 2 x 6, six feet long.

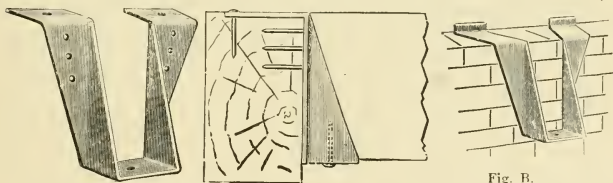

Fig. A.  
Style A for Wood Headers or Girders.

Fig. B.  
Style B and B 1 for Brick Walls.



Fig. C.  
Style E; Double Hanger over 1 Beam.

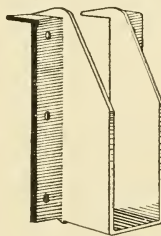

Fig. D.  
The National Hanger.  
Forged from mild steel.

Fig. D, shows the "National hanger" which is also forged from mild steel.

## CHAPTER VIII.

### SPECIFICATIONS.

---

272. Too much emphasis cannot be given to the importance of complete and concise specifications for any building, for it is the specifications that defines the quality of the work and materials, and to a very large extent the cost of the building, and the various questions that arise during the progress of the work. The first requisite in specifications is that they shall cover every part of the work ; the second, that they shall be written so as to be readily comprehended by the contractor and his foremen, and the third, that they shall be concise, describing as accurately as possible the quality of the materials to be used, how the work is to be done and everything that effects the cost that is not sufficiently shown by the plans and details.

It is also desirable that all work of the same kind or character shall be described in the same place, and not scattered through the specifications. The architect should not expect the contractor to do anything not provided for by the plans and specifications without extra compensation, nor to do the work better than the specifications call for. He must therefore be sure that everything which he wishes done is clearly indicated either by the plans or specifications, and that no loopholes are allowed for poor workmanship or inferior materials. The portions of the work to be done by each contractor should also be clearly stated, so that there can be no misunderstanding as to who is to do certain portions of the work. It very often happens that some minor details, such as closing up the windows, protecting stonework, drying out the building, etc., are not properly specified, and the contractors dispute, much to the annoyance of the architect, as to who shall do that part of the work. Such annoyances are largely avoided when the entire contract for the erection and completion of the building is given to one person or firm, but even then it is better to have the duties of the sub-contractors clearly defined.

As a rule, the form, dimensions and quantity of all constructive materials should be fully indicated on the drawings, so that only the kind and quality of the materials and the manner of doing the work need be given in the specifications. In regard to the finish, both exterior and interior, the wording of the specifications will depend

in a great measure upon whether or not the detail drawings are made before the work is estimated on. If detail drawings are furnished to the contractor with the general drawings the specifications may be much abbreviated, but if such details are not made, the size of all mouldings, the number and size of members, and the amount of dentil work, carving, turned mouldings, etc., should be accurately described, and the detail drawings should be made to conform to the specifications. Free hand sketches in the margin may be effectively used for illustrating this part of the specification. General clauses should be avoided as far as possible, as they only cumber the specification and tend to obscure the really important portions.

The following forms of specifications for the various kinds of work generally included in the carpenter's contract are given merely as a guide or reminder to architects, and not always to be copied literally.\* Figures or words enclosed in ( ) may be changed to suit special or local conditions or the preference of the architect, or are suggested in place of the preceding word or words.

Every specification should be prepared with special reference to the particular building for which it is intended.

The use of standard specifications is not recommended, as when such specifications are used the architect is more apt to overlook important points, and the use of such forms, moreover, tends to a lack of progressiveness and a study of the best construction to suit the varying circumstances of different buildings.

The author would recommend to the young architect that before commencing to write or dictate his specifications he make a skeleton, consisting of headings of the different items to be specified, carefully looking over the plans and revising the skeleton until everything seems to be covered and the headings arranged in their proper sequence. The specifications can then be filled out in the manner herein indicated.

#### GENERAL CONDITIONS.

**273.** Every specification should be preceded by the general conditions governing all contractors. These may advantageously be printed on a separate sheet and used as a cover to the written specification, and should not be repeated in the latter.

The general conditions used by different architects vary more or less, according to the experience of the architect. Legal provisions relating more particularly to the carrying out of the contract are

---

\*For specifications for mason work, plastering and fireproofing, see Part I.

sometimes included in the specifications, but it seems best to incorporate them into the contract only.

The following form has been used by the author for a number of years with satisfactory results :

**General Conditions:**—The contractor is to give his personal superintendence and direction to the work, keeping, also, a competent foreman constantly on the ground. He is to provide all labor, transportation, materials, apparatus, scaffolding and utensils necessary for the complete and substantial execution of everything described, shown or reasonably implied in the drawings and specifications as belonging to the work included in his contract.

*All material and workmanship to be of the best quality throughout.*

*The contractor must carefully lay out his work and be responsible for any mistakes he may make, and any injury to others resulting from them.*

*Where no figures or memoranda are given, the drawings shall be accurately followed according to their scale; but figures or memoranda are to be preferred to the scale in all cases of difference.*

*In any and all cases of discrepancy in figures, the matter shall be immediately submitted to the architect for his decision, and without such decision said discrepancy shall not be adjusted by the contractor save and only at his own risk; and in the settlement of any complications arising from such adjustment, the contractor shall bear all the extra expense involved.*

*The plans and these specifications are to be considered co-operative; and all works necessary to the completion of the design, drawn on the plans, and not described herein, and all works described herein and not drawn on the plans, are to be considered a portion of the contract, and must be executed in a thorough manner, with the best of materials, the same as if fully specified.*

*The architect will supply full-size drawings of all details, and any work constructed without such drawings, or not in accordance with them, must be taken down and replaced at the contractor's expense.*

*Any material delivered or work erected not in accordance with the plans and these specifications must be removed at the contractor's expense and replaced with other material or work, satisfactory to the architect, at any time during the progress of the work. Or in case the nature of the defects shall be such that it is not expedient to have it corrected, the architect shall have the right to deduct such sums of money as he considers a proper equivalent for the difference in the value of the materials or work from that specified, or the damage to the building, from the amount due the contractor on the final settlement of the accounts.*

*The contractor will provide proper and sufficient safeguards and protection against the occurrence of any accidents, injuries, damages or hurt to any person or property during the progress of the work, and shall be alone responsible, and not the owner or the architect, who will not in any manner be answerable for any loss or damage that may happen to the work, or any part thereof, or for any of the materials or tools used and employed in finishing and completing the work.*

*The contractor must produce, when called upon by the architect, vouchers from the sub-contractors to show that the work is being paid for as it proceeds.*

*Every facility must be given the architect for inspecting the building in safety, such as ladders, scaffolding and gangways, and provision to be made to the architect's satisfaction for protection from falling materials.*

*The drawings* are the property of the architect and must be returned to him before the final payment is made.

*The contractor* is to keep the building at all times free from rubbish and shavings, and on completion to remove all rubbish and waste material caused by any operations under his charge, clean up the house and grounds, and leave the work perfect in every respect.

If the contractor is to pay for *insurance* on the building it should be so stated in the specifications and also incorporated in the contract.

**274.—Carpenters' Work.\*—Frame Buildings.**—[As the carpenters' work required to erect a frame building and prepare it for plastering is so different from that required on a brick building, not only in framing and covering the walls, but also in the details of the window frames and usually of the exterior finish, the author has thought it best to give separate specifications for frame and brick buildings, up to the point where they are enclosed for lathing. Beyond that point, a single form of specification will answer for all ordinary buildings, whether of brick, stone or frame.]

*Timber.*—The whole of the timber used in and throughout the building to be the best of its respective kind, full and square to the dimensions indicated, well seasoned, free from large or loose knots, sap, shakes or other imperfections impairing its durability or strength.

Sleepers under basement floor to be of chestnut (locust, cypress or redwood), 4x4 inches, and 18 inches on centres.

Posts supporting porch floors to be of cedar (redwood), 6 inches in diameter at the smallest end.

*Hard Pine.*—The girders supporting first floor, and the posts supporting the same, to be of long leaf yellow pine. This is not usual in frame houses. Also the partition caps.

*Spruce.*—The posts, sills, girts and first and second floor joists are to be of spruce (Norway pine, native pine).

*Hemlock.*—All other framing timber to be of hemlock.

[It is much better to have all the framing timber of spruce or pine, although hemlock is largely used in some localities.]

All framing timbers and scantling to be of the sizes and distances apart indicated on the framing plans (or sections).

[It is customary with many architects to put the size of all framing timbers in the specifications, and when there are no framing plans it is best to do this. When all of the dimensions are marked on the drawings the author believes it is better not to repeat them in the specifications.]

Any other timber not shown on the drawings, but required to carry out the evident intent of the plans in a proper manner, is to be furnished by the contractor.

\*For specifications for mason work of all kinds, including plastering and fireproofing, see Part I.

**275.—Framing.**—The building is to be full frame, all framed, braced, spiked and pinned in the best and strongest manner, perfectly true and plumb and in accordance with the framing drawings.

No woodwork is to be placed within 1 inch of the outside of any chimney and no nails are to be driven into any chimney. [See Section 147.]

The underside of sills and ends of girders to be painted two coats of linseed oil paint before they are set in place.

The sills are to be halved at the corners and spliced with a scarf joint. All sills 20 feet long and under to be in one piece.

The first floor joists are to be notched down (4) inches on the sill and mortised 2 inches more into it, bringing the bottom of the joists flush with the bottom of the sill [see Fig. 25] (or to be hung in Goetz or Duplex joist hangers). The joists to be sized so as to be perfectly level and in line on top, and to be framed flush with girders by tenon and tusk [as shown in Fig. 28.]

All to be well spiked to sill and girders.

Beams of second and third floors to be crowned  $\frac{3}{4}$  inch in 20 feet and sized 1 inch on girts and partition caps and well spiked.

[If the ceiling is not to be furred the beams should also be sized to a uniform width.]

The posts are to be tenoned into sill and girts into posts, and pinned. Braces to be 3x4 inches, tenoned and pinned into posts, sill or girt. Studding to be cut with 2-inch tenon at lower end and well spiked at upper end with 2od's. No studding to be spliced.

Studding each side of all openings to be doubled.

The plate to be made of two pieces of 2x4-inch scantling, breaking joint and securely spiked to posts and studding.

Double the floor joists under all partitions running the same way; the joists to be set 4 inches apart [see Section 65] and bridged every 2 feet with pieces of floor joist 4 inches long, securely spiked.

Frame around all openings with headers and trimmers of the sizes marked on plans. The headers to be tenoned and spiked to the trimmers, and the tail beams tenoned to the headers.

[If special construction, such as fitch plate headers or steel beams is required, it should be specified here.]

All headers over (8 feet) long are to be hung in ( $\frac{3}{8}$ x3-inch) stirrup irons or patent joist hangers.

**Bridging.**—Cross-bridge all floor beams with one row of bridging for spans of from 8 to 16 feet, and with two rows to all spans exceeding 16 feet (or where shown on framing plans) of (1x3-inch\*) stock cut to fit and nailed with two 8d. nails at each end of each piece.

**Piazza and Porch Floor.**—Piazza and porch floors to be framed with a (4x10-inch) girder from each post or pier to the house, set so that the top of the girder will be (flush) with the top of sill, and pitching away from the house 1 inch in (6) feet. Each girder to be gained 1 inch into the whole depth of the sill and to be secured to the sill by a  $\frac{1}{4}$ x2 $\frac{1}{2}$ -inch flat iron tie, turned over inside of sill and spiked to sill and girder with three 2od. spikes. The outer end of girder to be supported on

\*For warehouse floors or 14-inch beams, 2x3-inch stock is generally used.



brick piers built by the mason (or on cedar posts 6 inches in diameter at the top, set 4 feet in the ground and tamped with sand and gravel).

Between the girders are to be framed the (2x6-inch) floor joists, set 20 inches on centres parallel to the house and all (flush on top) with the girder.

*Piazza and Porch Roof.*—The roof of the front piazza to be hipped with (2x8-inch) hip rafters and (2x6-inch) jack rafters, with a pitch of ( $\frac{1}{2}$  inch) to the foot. Upper end of hip rafters and inner jack rafters to be well spiked to the wall.

The rafters to be supported by a (4x8-inch) plate, supported by 4x4-inch uprights over the posts, which are not to be put in place until the finish work is put up. Fur under the plate for the architrave and cornice with 2x4-inch studding, 20 inches on centres, toe nailed to underside of plate and with a 2x4-inch soffit at the bottom.

The wall end of plate to be firmly secured to the studding of the house.

The rear porch to have shed roofed with 2x6 rafters, 20 inches on centres and 4x6 plate.

*Main Roof.*—The main roof of the house is to be framed as shown on framing plan (or in the strongest manner) with valley rafters carried to ridge or hips and 2x10-inch ridge pole. All hips and ridges to be maintained perfectly straight. Rafters to be notched on the plate and spiked. (The overhang of rafters to be dressed three sides and sawed to the pattern shown on detail drawing.) Double the rafters at each side of dormer openings with 4x8-inch header, 8 feet above attic floor, (or cut in (2x8-inch) valley rafters to intersect with dormer roof).

Partitions to be carried up to support roof wherever practicable, and all to be thoroughly tied and made perfectly secure and strong.

Spike 2x4-inch collar beams to each pair of rafters, 8 feet 2 inches above attic floor joists.

*Dormers.*—Frame the dormers with 4x4-inch corner posts, 2x4-inch studding and plate, and 2x6-inch rafters. The studding to be notched 1 inch on the rafters and extended to the floor. [See Section 82.]

**276.**—*Sheathing* (Boarding).—Cover the roof of front porch (which is to be tinned) with 4-inch matched pine (spruce) boards, dressed one side to a uniform thickness and free from large or loose knots or knot holes. To be nailed to every bearing with two 8d. nails, and all uneven places smoothed with a plane.

Cover all other roofs and all frame walls, including walls of bay window and dormers, with good sound hemlock (spruce, native pine) boards\* not over (10 inches) wide, dressed one side, laid close together and nailed to every bearing with two 8d. nails. Boards to be set diagonally on the walls of house and horizontally elsewhere. Form crickets on roof, behind chimneys, to turn the water.

**277.**—*Outside Finish.*—All outside finish, unless otherwise specified, to be worked from (clear) (good) thoroughly seasoned white pine (cypress, redwood) in strict accordance with elevation and detail drawings and to be put up in a skillful manner, with close joints and nails sunk for puttying. Joints exposed to the weather to be matched and painted with thick white lead before putting the pieces together.

*Cornices.*—The main cornice is to be supported by false rafters, sawed from (3x8-inch) white pine (cypress or redwood), free from large or loose knots, dressed on the two sides and securely fastened to the plate and rafters by 40d. spikes. Cut

\*If the house is to be back plastered, the Byr Kitt-Hall sheathing lath should be used. See Section 143

plank headers between the common rafters, to secure the end of false rafters, where necessary.

Rafter ends to be spaced uniformly (20 inches) on centres. Put a 10-inch moulded frieze board on the walls, directly under the rafters, and cut an 8-inch board between the rafters and against the frieze. To be gained  $\frac{3}{8}$  inch into the rafters.

Cover the overhang of eaves with  $4 \times \frac{7}{8}$ -inch matched pine ceiling, face side down, and over this with common sheathing.

Finish the outer edge of cornice with (1x4-inch) crown mould and ( $1\frac{1}{2} \times 4\frac{1}{2}$ -inch) fascia.

*Gutter on Roof.*—Form the gutters on the roof with ( $1\frac{1}{2} \times 4$ -inch) cypress strips set on edge and nailed to the roof over the shingles, and put up ( $1\frac{3}{4} \times 3 \times 5$ -inch) sawed pine brackets, set (30 inches) apart. The gutters to have a fall to outlets equal to 1 inch in 20 feet. The eaves of dormers to be finished in the same manner as the eaves of house, but with (3x6-inch) rafter ends and without a gutter.

*Box Cornice.*—Form the cornice on ell with (1x4-inch) crown mould ( $\frac{7}{8} \times 4\frac{1}{2}$ -inch) fascia, ( $\frac{3}{4} \times 10$ -inch) planceer, 8-inch frieze and (1x2-inch) sprung bed mould

[Dentils, carved mouldings, brackets, frieze ornaments, etc., if any, to be described here.]

*Cornice with Wooden Gutter* (Fig. 129).—Finish the eaves with rafter ends dressed and sawed to a pattern, as shown on detail drawings;  $\frac{3}{4} \times 8$ -inch moulded frieze against the wall, with a  $\frac{7}{8}$ -inch board cut between the rafters and gained  $\frac{1}{4}$  inch into them, and driven down against the frieze to make a tight joint. Cover the overhang with  $\frac{7}{8} \times 4$ -inch matched and beaded ceiling, face side down, and over this with the common sheathing.

Finish the edge of eaves with 4x6-inch cypress gutter with  $1\frac{1}{2} \times 4$ -inch fascia under, and  $\frac{1}{2}$ -inch cove moulding, as shown on section drawing, the back of the gutter to be open. Gutter to be in as long lengths as practicable, and where necessary to piece, to be lined with sheet lead  $\frac{1}{4}$  inches each side of joint.

*Raking Cornice.*—Form the raking cornice with (crown mould stuck to intersect with the crown mould on the eaves)  $4\frac{1}{2}$ -inch fascia,  $\frac{3}{4} \times 10$ -inch planceer, 10-inch moulded frieze and  $2\frac{1}{2} \times \frac{7}{8}$ -inch sprung bed mould (dentiles, brackets, etc.).

*Verge Boards.*—Finish the gable ends with  $1\frac{1}{2} \times 10$ -inch verge boards, paneled as shown on drawings, by planting on  $\frac{3}{4} \times 2$ -inch strips, and with (turned rosettes in the small panels). Finish above the verge board with 1x4-inch crown mould. The verge boards to set 12 inches from the wall and to be supported by 2x4-inch look-outs 2 feet apart. Cover the soffit with  $3 \times \frac{7}{8}$ -inch matched and beaded pine ceiling, with 6-inch boards against the wall and  $2 \times \frac{3}{4}$ -inch bed mould.

Place brackets back of the verge boards, at the corners of the building, to stop the gable finish; to be 4 inches thick, with moulded edge and (paneled) sides, as per detail drawing.

*Belts.*—Form the belts at base of front gable and at second floor level, by putting on furrings over each stud on top of the sheathing (boarding) and putting a second boarding outside brought to a feather edge at the top. Finish under the projection with  $\frac{3}{4} \times 6$ -inch board over the siding and 1x7-inch sprung moulding (or brackets, dentiles, etc., according to the character of the finish).

[Describe any other belts there may be on the house.]

*Base and Water Table.*—The sides of house next to piazza and porch to have

(1 $\frac{3}{8}$ x6-inch) base rebated on top and with a small level. Base to stop against piazza posts.

Elsewhere, form a water table just above the underpinning, as shown by scale detail (Fig. 156). The top piece to have a feather edge and the clapboards to come down over it. (Flash behind the clapboarding and 1 $\frac{1}{4}$ -inch on water table with long strips of zinc, 3 inches wide, nailed the sheathing.)

*Corner Boards.*—Put (1 $\frac{1}{2}$ x4-inch) corner boards on all external angles where the wall is covered with siding (or clapboards) with a single strip 1 $\frac{1}{2}$ x3 inches at internal angles.

*Other Outside Finish.*—[Any special outside finish, such as pilasters, architraves, etc., should be specified here.]

*Carving.*—Furnish and put up all carved work shown on the drawings, to be executed by a skilled carver in strict accordance with the detail drawings and from the best quality of white pine (whitewood or cypress)

(All carved panels or ornaments must be worked from the solid and not p'anted on. Before any carving is done the contractor must submit a full-size clay or plaster model to the architect for approval.)

*Composition Work.*—Furnish and put up the ornamental composition work where indicated on the elevation drawings. The work to be executed by a skilled modeler in strict accordance with the detailed drawings and put up in the best manner.

*Scuttle.*—Make scuttle (2 feet x 2 feet 6 inches) in roof where directed. To have plank frame, 6 inches high, and cover formed of  $\frac{3}{4}$ -inch flooring and 1 $\frac{1}{2}$ x3-inch cleats, with  $\frac{3}{4}$ x2-inch strip around the edge. Cover to be hung with heavy strap hinges and to have iron bar fastenings and fixtures to keep it open at any desired angle. Frame and cover to be tinned by the tinner.

[If the scuttle is in a deck roof the specifications should call for permanent steps or ladder, from the attic floor; or if the space below is finished, for a portable ladder, to be left on the premises.]

*Skylight.*—[If there is a wooden skylight on the roof it should be specified here. See Section 128.]

**278.—Shingle Roofing.**—Cover all roofs, except those marked to be tinned, with one layer of Neponset waterproof paper, with 2-inch lap, and best quality of sawed cedar (cypress, redwood) shingles, laid 4 $\frac{1}{2}$  inches to the weather [see Section 130] and nailed with two (galvanized) nails to each shingle.

(All shingles to be dipped (8 inches) in pure boiled linseed oil (Cabot's creosote stain, No. —) by the (painter) before laying.)

Finish the hips by laying a course of (4-inch) shingles parallel with the hips on each side, over the other shingles, and each course lapping the other alternately. The shingles to be laid to a straight edge so that the angle will be perfectly straight.

[For other methods of forming hips, see Section 131.]

Finish the ridge with 6x $\frac{3}{4}$ -inch saddle boards, tongued and grooved together (or, the ridges will be covered by a galvanized iron cresting, as specified elsewhere).

**Flashing and Tinning.**—All flashing to be of Merchant's or Taylor's Old Style tin, painted both sides before laying, to be IX. for the valleys and gutters and IC elsewhere (or 16-ounce copper); all to be furnished and painted by the tinner, and

put on by him, with the exception of the tin shingles, which are to be worked in with the shingles by the carpenter.

[In many localities the carpenter puts on all of the flashing, buys the tin and cuts it up himself.]

*Valleys (open).*—Line the main valleys with strips of tin, 20 inches wide, with end joints locked and soldered. The valleys formed by dormer roofs to be lined with tin 14 inches wide.

[Close valleys—see Section 133—should be specified as follows: Form the valleys by working pieces of tin, 9x14 inches, in each course of shingles.]

Flash against the chimneys, sides of dormers, where the porch roof joins the wall, and all rising parts, with tin, cut to turn up ( $3\frac{1}{2}$  inches) on the wall or chimney and 3 inches on the roof. Where tin "shingles" are used they are to be not less than  $7 \times 6\frac{3}{8}$  inches.

Cover the "crickets" behind the chimneys with tin turned up 4 inches on the roof and 3 inches against the chimney.

Furnish wide tin apron, to go under dormer sills, and carried up and nailed on the inside

*Counter flash* all flashing against brick or stonework with 4-pound lead, wedged (built) into the joints of the masonry at least 1 inch, with lead wedges, and turned down over the flashing to within 1 inch of the roof. Point above the flashing with elastic cement.

Tin the curb and cover of scuttle, to make a tight job.

Do any and all other flashing necessary to make the roof tight, and stop all leaks caused by workmen.

**279.—Tin and Galvanized Iron Work.**—*Piazza Roof.*—Cover the piazza roof with Merchant's or Taylor's Old Style IC. tin, sheets 14x20 inches in size. The tin to be laid over one thickness of dry felt, with joints locked and soldered in the best manner and secured to the roof by three tin cleats to each sheet; rosin only to be used as a flux for soldering. Carry the tin 4 inches up on the sheathing under the siding (or shingles) and over the edge of the crown mould of cornice and secure by galvanized wire nails.

Turn the tin up 4 inches around all balcony posts, soldering at the angles, and make the roof tight in every place.

*Gutter.*—Line the gutter on the roof with IX. tin (20) inches wide, with end joints locked and soldered. The tin to be turned over the edge of standing strip and secured every (4 inches) with galvanized wire nails.

*Hanging Gutter.*—Put a 5-inch half-round galvanized iron gutter under eaves of rear porch, supported every 3 feet by Berger hangers screwed to the fascia and adjusted to give a fall of (1 inch) to the gutter.

*Conductors.*—Furnish and put up where shown on elevation drawings (five) galvanized iron conductors from gutter on main roof, two from the ell, two from front porch and one from rear porch.

Those from main roof to be corrugated  $3\frac{1}{2} \times 4\frac{1}{4}$  inches in size, with ornamental heads, made according to elevation and detail drawings. Those from ell roof to be ( $3\frac{1}{2}$ ) inch round pipe, without heads, and those from porch and piazza to be  $2\frac{1}{2}$  inches in diameter

All to be secured to the wall by galvanized iron hooks, or clamps, so that they will stand clear from all mouldings and to be properly connected with the gutter. Conductors to terminate with a (3-inch) offset, 6 inches above grade (or to be connected with drain).

Cover the openings in the gutters with galvanized wire baskets.

The tinner is also to furnish (and put on) the flashing as specified above. All tin for roofs to be painted on under side, and all tin flashing valleys, gutters, etc., to be painted both sides by the tinner before putting up with red lead and linseed oil paint.

*Guarantee.*—The carpenter is to give the owner a written guarantee to keep all roofs and gutters tight for (one) year from date of completion free of charge.

[For wooden conductors and lead goose necks, see Section 116.]

**280.—Wall and Gable Shingling.**—Cover the walls of second story, and all gables, walls of dormers, etc., with the best quality of sawed cedar shingles in widths of from 4 to 8 inches (or in 6-inch widths) laid 5 inches to the weather and nailed with two common nails to each shingle. Where shingles come against door or window casings, nail only at the side next the casing. Under window sills and elsewhere, where exposed, the nails to be galvanized.

Shingles in gables to be laid alternately long and short, without selecting for uniform width, the difference in length to be (1½) inches.

*Cut Shingles.*—Cut shingles of uniform width and of pattern shown on drawings to be used where shown on elevation drawings.

[Wall shingles may be laid as much as 6 inches to the weather or 6½ inches with 18-inch shingles.]

**Siding.**—All other portions of the walls to be covered with clear white pine (Oregon pine, spruce, redwood, cypress) lap siding, 6 inches wide, laid 4½ inches to the weather and well nailed over every bearing with 6d. nails set in for putting.

No butt joints will be allowed in panels 12 inches long and under, and no butt joints are to come over window openings in the first course above such opening.

[In place of lap (beveled) siding, drop or novelty siding, moulded as per detail drawing, may be specified.]

*Clapboards.*—[Used instead of siding in some localities.]

All other portions of the wall to be covered with sap-extra pine (clear spruce) clapboards, all laid to a perfectly even gauge of not over 4½ inches and nailed to every stud with 6d. (galvanized) nails set in for putting (For butt joints see above.)

*Sheathing Paper.*—The sheathing under all siding (or clapboards) to be covered with one thickness of (H. W. Johns' medium weight asbestos sheathing felt) laid with not less than 2-inch lap. Line with the same felt under all corner boards, casings, etc.

*Zinc.*—Put strips of zinc 3 inches wide around all window and door casings throughout, turned up ¾ inch against casings and laid under the clapboards.

[Two inch by 7-inch tin shingles are sometimes laid in with the shingles against the casings.]

**281.—Piazza.**—Finish the front piazza as shown by elevation and detail drawings (Fig. 160 B).

Lay the floor with  $(1\frac{1}{2} \times 4$ -inch) matched Georgia pine (white pine flooring), tightly strained and blind nailed to every bearing with 8d. nails, and the joints run in white lead. Finish the edges of floor with rounded nosing and  $\frac{3}{4} \times 1$ -inch cove under. Finish under the edge with  $\frac{7}{8}$ -inch pine casings (8 inches) wide. Case the piers with (12-inch) pine boards with beveled base. Fill between the piers with lattice work formed of  $\frac{3}{4} \times 2\frac{1}{2}$ -inch strips halved together, with spaces  $2\frac{1}{2}$  inches square, and frame with  $\frac{3}{4}$ -inch pine boards, 4 inches wide. (Each panel of lattice work to be put together in one piece, so that it may be removed if desired.)

The posts to be turned from 10x10-inch whitewood (redwood or cypress) and extended inside of the pedestal to the floor. The caps to be made from a separate piece of wood and carved as per full-size detail. Base to be turned in two pieces and fitted around the post, the congè and fillet to be turned on the post. The flutings are to diminish, leaving the fillets the same width throughout their length. Form the pedestal about the post with  $1\frac{1}{2}$ -inch pine frame, plain panels and  $\frac{1}{2} \times \frac{3}{4}$ -inch panel mould, with  $\frac{7}{8}$ -inch beveled base, mitred at the angles.

Put a half pilaster against the wall, fluted to correspond with posts and with base and pedestal to correspond.

The cap to correspond with section of rail. Form the architrave and cornice with wide pine casings,  $1\frac{1}{2} \times 2\frac{1}{2}$ -inch band mould, inside and outside, and  $\frac{7}{8} \times 2\frac{1}{2}$ -inch bed mould;  $\frac{7}{8} \times 4$ -inch crown mould, 4-inch fascia and 8-inch planceer.

Fur for level ceiling under the rafters and cover with  $\frac{3}{4} \times 4$ -inch (centre-beaded) clear pine ceiling, with bed mould same as under cornice.

Build the railings with top rails built up and moulded, and bottom rails stuck from  $2\frac{1}{2} \times 3\frac{1}{2}$ -inch stock, with upper edge beveled.

Top rail to be ramped and to mitre with cap of pedestal and posts. Balusters to be  $1\frac{5}{8}$ -inch, turned and set  $3\frac{1}{2}$  inches on centres.

The posts of upper balustrade to be turned from 5x5-inch whitewood, with turned ornament on top. Cap moulding to correspond with rail.

The posts to set on  $1\frac{5}{8}$ -inch pine block, 6 inches square, nailed over the tin roofing and covered with tin, soldered to the roof. Centre post to be secured by an iron brace. Put half posts against the wall to receive the balustrade.

Construct the steps on 2x10-inch plank carriages, 16 inches on centres and resting on a 4x6-inch sleeper at the bottom. [A flat stone is better.] Treads to be  $1\frac{1}{4}$ -inch thick with rounded nosing and cove under, returned at the ends. Risers  $\frac{7}{8}$  inch thick. Finish the ends of steps with  $\frac{7}{8}$ -inch pine string and casings, with panel formed of  $\frac{3}{4} \times 4$ -inch centre beaded pine ceiling.

**282.—Rear Porch.**—Lay the floor of rear porch with  $\frac{7}{8} \times 4$ -inch clear (hard pine) boards, dressed one side, with square edges, and laid  $\frac{1}{4}$  inch apart. Finish the edges of floor with rounded nosing and  $\frac{3}{4} \times 1$ -inch cove moulding. Finish under the edge of floor with 10-inch pine casings; case the piers (or posts) beneath the floor with wide pine boards and fill in between them with  $\frac{7}{8} \times 6$ -inch pine boards cut to pattern, as shown, and  $\frac{7}{8} \times 8$ -inch beveled base. The porch posts to be 5 inches square, built up of pine boards carefully fitted together. Finish the cornice with  $\frac{3}{4} \times 4$ -inch crown mould, fascia and planceer, as shown. Fill in the gable ends with  $\frac{7}{8} \times 4$ -inch double-faced pine ceiling. Fill in between the posts the full height of opening; also over the door, with diagonal lattice work, with strips  $\frac{1}{2} \times 1\frac{1}{2}$  inches, set  $1\frac{1}{2}$  inches apart.

Ceil on bottom of rafters with  $\frac{3}{4}$ x4-inch centre-beaded pine ceiling, with a  $\frac{7}{8}$ -inch quarter round broke 'around the edges.

Build the steps on 2x10-inch plank carriages, 16 inches on centres, resting on a 4x6-inch sleeper at the bottom. Treads to be  $1\frac{1}{4}$  inches thick, moulded nosing returned at the ends; risers  $\frac{7}{8}$  inch thick, all of white pine.

Fill under ends of steps with boards cut to pattern, as under porch, and with beveled base,

**283.—Cellar Hatchway** (or Bulkhead).—Make bulkhead entrance to cellar with plank steps on plank carriages, 16 inches on centres, all planed; no risers.

Cover the brick (or stone) walls with a strong plank frame bolted to the brick-work by two  $\frac{3}{4}$ -inch bolts 20 inches long on each side. Cover the frame with wide pine (cypress, redwood) boards, with 6-inch casing on sides. Construct double doors of 1x4-inch matched pine boards, secured with  $1\frac{1}{4}$ x6-inch beveled cross pieces screwed on the under side. The meeting joint to be battened and the bulkhead rendered water tight. Form a water way at the top, cover with tin and groove the edges of the frame next the doors, to catch the water entering at the joints. [See Section 108.]

Hang the doors with 8-inch heavy strap hinges bolted to the door and screwed to the frame, and provided with pivoted hard wood bar fastening.

[A single door may be secured by hook and staples.]

**284.—Windows.**—Make all window frames in accordance with the scale and detail drawings. All to be made of clear white pine (except pulley stiles and parting strips, which are to be of clear yellow pine).

*Cellar Windows.*—All windows in basement are to have  $1\frac{1}{4}$ -inch rebated frames and sills, with  $1\frac{3}{4}$ -inch moulded staff bead. Frames to be rebated on the outer edge for screens. The frames on sides and rear to have  $\frac{3}{4}$ -inch round vertical bars, from 3 to 4 inches on centres, let into head and sill. Frames to be fitted with  $1\frac{3}{8}$ -inch pine sashes, divided into lights as shown and glazed with first quality single strength glass. Sashes to be hinged at the top, fitted with hooks and staples to keep them open, and strong japanned iron button fastenings (bolts or slip latches).

Make frame only for cold-air opening and cover with heavy galvanized wire netting with  $\frac{3}{8}$ -inch mesh, nailed securely on outside of frame.

*Grilles.*—Furnish and fix in the front cellar window frames (with No. 14 screws) ornamental wrought iron grilles, made in the best manner in accordance with the detail drawings.

*Casement Windows.*—All casement, French and stationary sash frames are to have  $1\frac{3}{4}$ -inch rebated jambs and  $1\frac{3}{4}$ -inch sills, ploughed as per full-size section. The outer edge of frames to set flush with the sheathing and to have  $1\frac{1}{2}$ x $5\frac{1}{2}$ -inch casings and  $\frac{3}{4}$ x $2\frac{1}{2}$ -inch band mould.

The sash in small window in coat closet to be screwed in tight, the others to be hung at the sides to swing in.

*Double-Hung Windows.*—All other windows throughout the house are to have frames made for double-hung sash, with  $\frac{7}{8}$ -inch hard pine pulley stiles,  $\frac{7}{8}$ x $\frac{1}{2}$ -inch parting strips,  $\frac{3}{4}$ -inch ground casings,  $1\frac{3}{8}$ -inch yoke and  $1\frac{3}{8}$ -inch sills, pitching 1 inch and ploughed for shingles or clapboards, as required.

The pulley stiles to be tongued into outside casings and fitted with pockets to give access to the weights. The windows to be cased on the outside (over the

sheathing) with  $1\frac{1}{4} \times 5\frac{1}{2}$ -inch pine casings, with  $\frac{3}{4} \times 2\frac{1}{2}$ -inch band mould planted on. The windows in first story to have 10-inch frieze board above the band mould, with moulded cornice, with one row of dentiles, as per full-size detail. Flash over the top of all casings with strips of tin (zinc) 3 inches wide.

All frames for double-hung sashes are to have  $\frac{3}{8}$ -inch wood pendulums, hung from the yoke between the weights.

*Box Heads.*—The frames in [specify where] are to have box heads with the pulley stiles extending to the top. The sashes are to slide into the head with a follower.

**285.—Sashes.**—All sashes above the cellar are to be custom made of clear well-seasoned white pine (cypress), glued and wedged in the best manner, and divided into lights, as shown on the elevation drawings. All sash in first and second story windows of main house to be  $1\frac{3}{4}$  inches thick. All others to be  $1\frac{3}{8}$  ( $1\frac{1}{2}$ ) inches thick

The sash for French windows to have astragal mouldings on the meeting stiles and a bead on the jamb stiles to fit into the jamb, as per full-size sections; bottom rail to be  $5\frac{1}{2}$  inches wide.

*Paneled Doors Below Sash.*—The windows opening on to front balcony are to have two paneled doors below the lower sash, with a rebated joint in the centre and with a tongue on the top. The lower sash is to be grooved to fit over the tongue and both sashes are to slide up into a box head

*Storm Sashes.*—Provide outside sashes for all exterior windows in north and west elevations, made of clear, well-seasoned white pine (cypress), divided into four lights packed with listing around the edges and secured to the frame on the inside with (Willer's storm sash buttons, coppered finish) four to a window.

All storm sash are to be glazed with first quality double-strength glass, and are to be fitted and marked complete by the contractor and stored where directed.

*Priming.*—All sashes to be primed on both sides by the contractor before being brought to the building. Sashes for rooms which are to have a natural wood finish must be primed inside with pure boiled linseed oil.

**286.—Glass.**—The large lights of centre front window to be glazed with polished American plate glass, secured by wood beads.

All other windows in first and second stories of main house (except those marked "leaded glass") to be glazed with (Chambers' "Three Star" double strength glass). (Chambers' "Eagle Brand" 26-ounce crystal sheet) (first quality double strength American (German) glass).

All other sash to be glazed with first quality single strength glass.

All glass is to be well bedded, tacked and puttied.

*Leaded Glass.*—Allow the sum of \$ ——— for leaded glass for all sashes where indicated on elevation drawings. The glass to be ordered by the architect and paid for by the contractor. Contractor to deliver the sashes to the glazier when directed.

**287.—Outside Blinds.**—Provide and hang outside blinds for (all) windows above the basement. To be made of first quality white pine,  $1\frac{1}{2}$  inches thick with rolling slats (in the lower half only). Blinds for all windows 4 feet wide and over to be divided in four folds; all others to be in two folds.

All four-fold blinds to be hung with wrought iron L hinges and fastened with Hyde's Patent Gravity Lock Blind Fast. Blinds in two folds to be hung with Stanley Gravity Blind Hinges, No. 1647, and fitted with Stanley Wire Blind Fast.

[For blind hinges and fasts, see Sections 247 and 248.]



All blinds are to be marked and a corresponding mark is to be put on the frames.

**288.—Outside Door Frames**—All outside door frames to be made from clear pine stock  $1\frac{7}{8}$  inches thick, rebated and beaded on the inner edge, and with  $1\frac{3}{4}$ -inch moulded pine (oak) thresholds. All to be set plumb and square.

Case the frames on the outside over the sheathing with  $1\frac{1}{2} \times 5\frac{1}{2}$ -inch pine casings, back band, cornice, etc., to correspond with windows. The front entrance to have side lights and transom, fluted mullions with cap and base, and moulded transom bar with dentils. Side lights and transom sash to be (stationary)  $1\frac{3}{8}$  inches thick, divided into lights as shown, and glazed with 26-ounce crystal sheet glass.

Finish under the side lights with  $1\frac{3}{8}$ -inch sills and panel work inside and out. The frame and sashes to be veneered on the inside with kiln dried, quarter-sawed white oak, and the panels to be of oak.

All to be worked and put together in the best manner, and in strict accordance with the detail drawings. The oak veneering of frame to be filled and shellaced by the carpenter before bringing to the building.

**289.—Preparation for Tiling**.—Prepare the floor of bath room for tiling, by nailing  $\frac{3}{4}$ -inch boards on cleats nailed to the sides of the beams. The top of the boards to be (5 inches) below the top of the adjoining floor. Bevel the beams on both sides to an edge on top.

Prepare the side walls for tiling by nailing  $2 \times 3$ -inch pieces horizontally between the studs, about 12 inches apart, to a height of 4 feet [for metal lathing].

**290.—Under Flooring**.—Lay an under floor throughout the first and second stories of good hemlock, (spruce, native pine) boards, surfaced one side and nailed to every bearing with two 8d. nails.

The boards to be laid diagonally on the beams in first story of main house, and at right angles elsewhere. All end joints to be cut over a beam in every case, and suitable nailing pieces to be cut between the joists at the side walls for the diagonal flooring. The flooring must be run closely around all studs and up to the sheathing outside.

Lay a single floor in finished portions of attic (4-inch) clear Texas (spruce) flooring, matched and blind nailed, and tightly strained, with heading joints cut over a bearing in every case.

Smooth off all ridges due to uneven thickness of the boards as soon as the floor is laid.

**291.—Grounds and Furring**.—Put on grounds for  $\frac{3}{4}$ -inch ( $\frac{3}{8}$ -inch) plastering around all door and windows openings, and for bases, wainscoting, wood cornice, etc., as directed; two grounds behind the base.

Put up  $\frac{3}{4}$ -inch wood corner beads on all projecting corners, stuck as per marginal sketch (Fig. 193B), or, put Empire steel corner plates on all projecting angles, set true and plumb and well secured.

Cross-fur all ceilings, including basement ceiling with  $1 \times 2$ -inch strips, set 12 inches (16 inches) on centres. Cross-fur rafters in finished attic rooms diagonally with strips 12 inches on centres; fur out attic outside walls with studding to give (4-inch) vertical height, and fur down attic ceiling to (9 feet) clear height.

Fur for arches, cornices, ceiling beams, etc., as required by the scale drawings and full-size sections.

Fur for a plaster cove in parlor, and front chamber with brackets cut out of  $1\frac{1}{4}$ -inch boards, set 16 inches on centres.

Fur all chimney-breasts with 2x4-inch studs, set flatways, 1 inch clear of the brickwork and 16 inches on centres.

Fur outside stone walls of (laundry) with 2x4-inch studs, set flatways, and 16 inches on centres.

All furrings, grounds and angle beads to be perfectly strong, true and plumb.

**292.—Partitions.**—Set all partitions as shown by yellow color on the plans, with 2x4-inch (spruce) studs, sized to a uniform width, set 12 inches on centres for bearing partitions, and 16 inches for all other partitions, all straight and plumb. Try with a straight edge, and straighten and bridge before plastering.

All partitions except those that stand over each other, to stand on a 2x5½-inch sole piece, and all to have (3x4-inch) (hard pine) caps. Where a partition stands over another or over a wall or girder; the studs of the upper partition must stand on the cap of the partition below or on the girder—not on the floor nor on the beams. Truss over all openings in partitions which extend through more than one story or carry beams, with double headers 1-inch apart, and strongly truss all partitions not supported from below, to take the weight off the middle of the beams.

Form all corners and angles solid so that there can be no lathing through angles. All round corners are to be furred for horizontal or diagonal lathing.

Cut a 2-inch plank header between the studs over the pocket for sliding door partitions, (8 inches) above the soffit of the doors, and line the pockets below with ½x6-inch matched boards (painted both sides before putting up).

Bridge all partitions in first and second stories with (two) rows of horizontal (diagonal) bridging of 2x4-inch pieces cut in between the studding and nailed with two rod. nails at each end of each piece.

*Mineral Wool Filling.*—Fill in between studs at (south and east) sides of bath room with mineral wool from floor to ceiling.

*Mice Stops.*—Furnish and put down strips of tin, fermed to a right angle between the studs of all outside walls on each floor. This tin to be well nailed to the floor and the sheathing to prevent the circulation of mice. All holes around the studs at partitions are to be closed in the same way.

**Cutting and Fitting.**—Do all cutting and fitting required by plumbers, gas fitters and for furnace pipes and registers, repairing neatly afterwards. No bearing timbers to be cut without consulting the architect.

**293.—Temporary Enclosing.**—The contractor is to temporarily enclose the building as soon as it is ready for lathing, furnishing and hanging temporary doors with locks and covering the windows with muslin, boards or temporary sash—at least one-half of the openings to be closed with muslin.

No permanent sash to be set in the windows (except in unfinished attic) until the plastering is dry.

The foregoing specification is intended to cover all work required to complete the building on the outside ready for the painter, and to prepare it on the inside for the lather, with the exception of the rough work for the stairs. Occasionally this much of the work is let by itself, the finishing of the building being let under another contract.

**Specifications for the Carpenters' Work** of a brick dwelling, with steep roof in front, flat roof behind, both stopped by fire walls at the sides; copper cornice, copper bay window in second story, brick, stone and tiled front porch without roof.

Specifications to be preceded by the general conditions.

**294.—Privy.**—Build a temporary privy at rear of lot as soon as building operations are commenced, remove on completion (clean out) and fill up with earth, neatly leveled off.

**295.—Timber.**—[This may be specified as in Section 274. If the sizes are not all shown on the drawings they should be given in the specifications].

**Framing.**—Frame for floors, roof, ceiling and partitions in a substantial manner as shown on drawings and as herein described; furnish all joist hangers, steel beams, bearing plates, bolts, nuts and washers, indicated on the drawings and herein specified.

The carpenter is to exercise care in framing so that important timbers will not require cutting for furnace pipes, gas pipes, etc.

All framing must be kept 2 inches from the outside of the chimneys, and in no case will any timber be allowed to rest on the chimneys.

**Floor Framing.**—The laundry is to have a wooden floor formed of 2x8-inch joists, 16 inches on centres, resting on a dwarf wall in the centre and on ledges built in the foundation walls at the sides. All other portions of basement, except in coal bins, will have a cement floor.

**Girders and Posts.**—The dining room floor joists will be supported by an 8x10-inch hard pine girder in one length, supported at the ends by the brick partition walls with an 8x12x1-inch cast iron bearing plate under each end of girder. The centre of the girder to be supported by an 8x8-inch post, dressed four sides, and with chamfered corners. The post to rest on a 12x12x1 $\frac{1}{4}$ -inch cast iron plate with a dowel in the centre, bedded on the stone pier.

All other first floor joists to be supported by the partition walls. Furnish long 2x10-inch hard pine planks, and have the brick mason bed in mortar on the walls and level carefully.

The ends of all floor beams built into brick walls, to be beveled (3) inches and all floor joists to be crowned  $\frac{1}{4}$ -inch for every 12 feet of span. Where the ceilings are not furred the joists to be concaved on the under side to a uniform width.

All floor beams to be carefully leveled at their ends, and on the brick walls to be wedged up with hard bricks or slate chips—no bond timbers to be built into the walls.

Dining room beams to be framed flush with girder and supported in (Duplex) joist hangers.

Frame the first floor joists around all basement windows with double headers and trimmers, framed with tusk and tenon. Tail beams to be mortised 1 inch into header and well spiked.

Frame the floor beams, ceiling joists and rafters around all chimneys, hearths, scuttle, skylight and stair openings with double headers and trimmers, framed as above, except that all headers over 4 feet long shall be hung in Duplex joist hangers.

The trimmers for front stair well in second story to be 6x12-inch hard pine, extending from wall to partition, and the header to be formed of a 10-inch 25 pound

steel beam, with a 3x10-inch plank fitted between the flanges and bolted to each side with  $\frac{3}{4}$ -inch bolts, spaced 2 feet apart in the length of the beam and staggered. Header to be hung in Duplex hanger ( $\frac{3}{4}$ x3 $\frac{1}{2}$ -inch stirrup) at each end. Tail beams to be framed into the 3x10-inch plank (or hung in Duplex hangers) and every third beam to be tied to header by  $\frac{1}{2}$ -inch round iron dogs, hooked over the eyebeam and let into top of beams.

Frame for bay window in second story by bolting a 2x10-inch plank to the bottom of the opening, and frame 2x12-inch floor joists, 8 feet long, on top of this plate, extending, 4 feet inside of the wall with the inner end securely spiked to a 3x12-inch floor beam. The two outer beams to be 4 inches thick, with the common joists framed into them. Cut 2x4-inch pieces between the bay window joists, on a line with the other joists to receive the flooring.

Double the floor beams under all partitions running the same way, beams to be spaced 4 inches apart and blocked every 2 feet with 4-inch lengths of 2x12-inch joists securely spiked to each beam.

**296.—Bridging.**—[All floor beams should be bridged once in every 8 feet in length, as specified in Section 275.]

The ceiling over third story to be framed in the same way as the floors (without bridging), the beams resting on the wall and on the partition caps. Truss the beams from the rafters of flat roof, as shown on section drawing, with 1x6-inch boards, nailed to every beam and rafter with red nails. Put temporary supports under the ceiling joists, 6 feet from bearing walls, until the beams are trussed.

**297.—Roof Framing.**—Bolt a 4x10-inch plate in two thicknesses, breaking joint on top of front wall, with  $\frac{3}{4}$ -inch bolts, 30 inches long, built into the brick work by the mason, and spaced not over 6 feet apart.

Frame the pitch roof in front with 2x8-inch rafters, spiked to the wall plate, and with a 2x14 inch hard pine ridge in one length. Frame for dormer openings with 4x8-inch rafter on each side, and 4x10-inch header above the opening, 8 feet above the third floor.

Frame the flat roof with 2x8-inch joists, built into fire walls, and carry up the partitions running lengthways of the building to support them. Rafters to be trussed from ceiling joists as above specified. Frame for scuttle and skylight openings as in the floors.

Bolt a 2x10-inch plate on top of rear wall, the top flush with the top of roof joists, with  $\frac{3}{4}$ -inch bolts, 24 inches long and not over 6 feet apart.

**Dormers.**—Frame for dormers with 2x4-inch studding, 4x4-inch corner posts, 4x4-inch plate, double and breaking joint, and 2x6-inch rafters, all 16 inches on centres. The studding at sides of dormers to be notched 1 inch over the rafters and securely spiked.

**298.—Beam Anchors.**—Tie the floors, ceiling joists and rafters of flat roof to the side walls, every (6) feet by iron anchors, formed of  $\frac{1}{2}$ x2-inch iron, 20 inches long, with a 3x3x $\frac{1}{2}$ -inch plate, riveted to wall end (or turned up 4 inches in the wall.) To extend into the wall 8 inches and to be spiked to the side of the beams near the bottom by three 20d. spikes driven through the joists and cinched. Tie the ends of main ridge to side walls in the same way

The front and rear walls to be tied to the floor beams every 6 feet by cutting pieces of 2x4-inch joist between the beams and spiking the anchors on top. The fire walls at sides of pitch roof to be tied to the rafters twice on each side in the same way.

[The most effective anchors are those that pass entirely through the wall with a plate, head or nut and washer on the outside, but such can only be used where the appearance of the wall is not of consequence. Where such anchors are considered necessary on a finished wall, ornamental heads may be used.]

**Partitions.**—[These may be specified as in Section 292.]

**299.—Lintels, Arches, Wood Bricks, etc**—Put arched wooden lintels, 5 inches high at the centre, over all openings in brick walls; to be cambered  $1\frac{1}{2}$  inches at the ends and to rest not more than 1 inch on the brick work.

The opening for bay window in front wall to be spanned by two 10-inch 25 pound steel beams, bolted together with three cast separators and  $\frac{3}{4}$ -inch bolts, so that the lintel will be 11 inches wide out to out of flanges. The beams to have a bearing of 6 inches at the ends and to rest on 8x12x1 $\frac{1}{4}$ -inch cast iron plates, and to have an anchor 16 inches long at each end. Bolt a 2x8-inch plank on each side of the lintel.

[If any other special lintels are required, they should be specified here.]

Make and set all forms for brick or stone arches as required by the brick or stone masons, and any templates required.

Furnish and have the masons build into the walls wooden bricks ( $2\frac{1}{2}$  inches) thick, wherever necessary for the proper execution of the work. Furnish a piece of 2x4-inch spruce, and have the masons build into the wall back of all window sills.

The carpenter is to splice 3x4-inch joists to the ends of the rafters of flat roof, flush with inside of fire wall to hold the flashing.

**300.—Lookouts and Bond Timbers for Cornice.**—Furnish and set 2-inch plank lookouts for the front cornice, notched for the plate, and 3x4-inch bond timber for the moulding under frieze, and 2x4-inch vertical pieces every 26 inches for securing the frieze; to be built in by the brick mason.

**301.—Framing for Bay Window.**—Frame for the bay window in second story with 2x6-inch studding, 2x6-inch sole piece, spiked to top of joists, 4x6-inch plate breaking joint, and 2x6 inch rafters. Sheath the outside and roof and under the floor joists with  $\frac{7}{8}$ -inch native pine (hemlock) sheathing, surfaced one side to a uniform thickness. The sides of bay and the roof to be secured to the front wall by (six)  $\frac{3}{4}$ -inch bolts, 14 inches long, with 4x4x $\frac{1}{4}$ -inch washers built into the wall.

**Protecting Stonework.**—The carpenter is to protect all stone sills, steps, coping, jambs, carved capitals and other parts of the stonework likely to be injured, by covering with boards properly secured and maintained until all exterior work is completed, including the painting.

**302.—Sheathing and Under Floors.**—Cover all roofs and sides of dormers with native pine (spruce or hemlock) sheathing, free from holes or large knots, surfaced one side to an even thickness and nailed to every bearing with two 8d. nails.

Form a ridge pole on main ridge, made of two  $1\frac{1}{2}$ x6-inch boards, clinched together and set over the sheathing and spiked to it.

*Under Floors.*—[These may be specified as in Section 290, the boards to be laid close against the walls.]

**303.—Scuttle and Skylight.**—[Scuttle may be specified as in Section 277.]

Make frame for skylight (on flat roof) of  $1\frac{3}{4}$ -inch pine planks,  $11\frac{1}{2}$  inches wide, set on top of the sheathing and pitching 6 inches toward the rear. Top of frame to be grooved as per detail and the outside to be tinned by the tinner. Cover the frame with a skylight sash  $2\frac{1}{2}$  inches thick, and 2 inches wider than the frame, with a  $\frac{3}{4}$ -inch strip nailed to the under side to fit against the frame. The sash to be glazed with  $\frac{3}{8}$ -inch ribbed glass, each light to be the full length of the sash. Hang the sash with heavy wrought iron butts and secure with bar fastening. Ceil the sides of opening from the third story ceiling to the under side of sash with  $\frac{5}{8}$ x4-inch (pine) ceiling.

Put a  $1\frac{1}{2}$ x8-inch pine board across rear wall, with the top edge flush with sheathing to receive the gutter, and put a  $1\frac{1}{4}$ -inch quarter round moulding under the gutter.

*Bulkhead.*—[Same as in Section 283.]

**304.—Rear Porch.**—Construct the porch floor with 2x6-inch joists, 16 inches on centres, placed parallel with the rear wall and framed flush between 6x8-inch girders resting on the brick piers.

Cover the floor with  $\frac{3}{4}$ x4-inch (quarter-sawed) hard pine flooring, matched and blind nailed and tightly strained. Edges of floor to be rounded with a cove under. Finish under the floor and in front of the piers with wide white pine casings, and fill in the spaces between piers with (diagonal) lattice work  $\frac{1}{4}$ x $1\frac{1}{8}$ -inch, with  $1\frac{1}{8}$ -inch spaces and  $1\frac{1}{4}$ x7-inch beveled base. Build the steps on 2x10-inch plank carriages, 16 inches on centres, resting at the bottom on a long stone slab. Treads to be  $1\frac{1}{4}$  inches thick, risers  $\frac{3}{4}$ -inch, rounded nosings, returned at the ends with cove under. Case the strings with  $\frac{3}{4}$ -inch pine boards and fill in to ground with lattice work same as under porch, with  $\frac{3}{8}$ x5-inch frame and beveled base.

The posts are to be formed of 4x4-inch straight well seasoned spruce, cased with  $\frac{3}{8}$ -inch pine, with angles chamfered. The rough posts to be carried up to support a 6x8-inch plate. Rafters to be 2x6 inches with 2x8-inch hips.

Provide and have the mason build into the rear wall (four)  $\frac{3}{4}$ -inch bolts, (14 inches) long, with 4-inch square washers to bolt the porch roof to the wall.

Fur under the rafters for level ceiling, and ceil with  $\frac{3}{4}$ x4-inch centre beaded ceiling, with  $\frac{3}{4}$ -inch quarter round around the edges.

Box under the plate for false beam as shown, and finish the cornice with (4-inch) crown mould, 4-inch fascia, 10-inch planceer and  $2\frac{1}{2}$ x $\frac{3}{4}$ -inch bed mould. Form a gutter back of crown mould as per section, the bottom to have a fall of 1-inch to outlet.

Roof and gutter to be covered with tin by the tinner.

Fill in between the posts with  $\frac{3}{4}$ x4-inch double faced pine ceiling (3 feet 6 inches) high, with 2x4-inch rail on top. Break a  $\frac{3}{8}$ -inch quarter round moulding around the ceiled panels inside and out. Cover the spaces above the rail and over

the door with No. 14 mesh painted wire cloth, nailed to the posts, rail and beam with half round moulding over the edge (or fit  $\frac{3}{8}$ -inch screens, mortised and tenoned together, in all openings above the rail and over the door, and cover the same with No. 14 mesh painted wire cloth.)

Construct the balcony rail with 5x5-inch solid turned whitewood posts, extended through the roof and spiked to the plate. After the roof is tinned, put on  $\frac{7}{8}$ -inch beveled base over the tin. Top rail to be  $3\frac{1}{2}$ x $3\frac{1}{2}$  inches double moulded of whitewood, lower rail  $2\frac{1}{2}$ x $3\frac{1}{2}$  inches, beaded on the sides and beveled on top. Balusters to be plain,  $1\frac{3}{4}$  inches, set 4 inches on centres.

All exposed woodwork about the porch to be of clear well seasoned white pine or cypress, except where otherwise specified.

Construct a slat floor in (two) sections to lay on tin roof. To be made of ( $1\frac{1}{2}$ x3-inch) hard pine strips, laid  $\frac{3}{4}$ -inch apart and nailed and clinched to  $1\frac{3}{4}$ x3-inch pine cleats, 2 feet on centres. Block up on top of the tin roof to make the floor level.

**305.—Window Frames.**—Make all window frames in accordance with the scale and detail drawings, and as herein specified of clear well seasoned white pine, and set in position as soon as the stone sills are set. The carpenter is to verify the measurements, to see that the sills are set in their proper position and if any sills are set wrong, he is to see that they are changed before setting the frames. All frames to be set plumb, kept well braced during the construction of the wall, and to be braced by cross pieces and diagonals to keep the frames square and the sides from springing.

*The cellar windows* to have 2x12-inch pine plank frames; free from sap or large knots, rebated for sash on the inside and for  $1\frac{1}{2}$ -inch screens on the outside;  $1\frac{3}{4}$ -inch staff bead, the head to be kept  $\frac{7}{8}$ -inch below the furring strips (floor joists) and a  $\frac{3}{8}$ -inch ground nailed on top.

The sill to have a pitch of 1 inch, and to be formed as per full-size section. [See Fig. 92 ]

The frames in rear and sides of building to be rebated on the outer edge for  $1\frac{1}{2}$ -inch screens and to have  $\frac{3}{4}$ -inch round bars let into the head sill from 3 to 4 inches on centres. The front frames to have ornamental iron grilles as per scale and detail drawings (furnished by the carpenter), screwed to the inside of frame, and strips nailed to the frame inside for the screens.

Furnish and fix with round headed blued screws,  $1\frac{1}{2}$ -inch screens for all cellar windows, covered with heavy galvanized wire netting on the outside and No. 14 mesh painted wire cloth on the inside.

All cellar windows to have  $1\frac{3}{4}$ -inch pine sash, made in the best manner, divided into lights as shown, glazed with first quality single strength glass, hinged at the top with japanned butts, and provided with hooks and eyes for holding open, and strong japanned button fastenings.

*Cold Air Opening.*—Make plank frame for cold air opening with  $1\frac{3}{4}$ -inch staff bead and cover with heavy galvanized netting nailed to the outside of frame.

*Dormer Frames.*—The jamb, head and sill of dormer window to be stuck from  $2\frac{1}{2}$ x10-inch pine planks, moulded, ploughed and rebated as per full-size section [Fig. 111]; transom and mullion from a  $3\frac{1}{2}$ x10-inch plank. The lower openings to be filled with a single sash hinged at the sides and the transom sash to be hinged at the bottom

The back of jambs and top of head to be flashed with strips of zinc 3 inches wide, bent at right angles.

*Bay Window.*—The bay window frames to be worked out of 1½-inch pine plank, ploughed for parting strips and blind stop, and to have 1¼-inch outside casings (which will be covered with copper). Sills 1¾ inches thick, stuck as per detail. The sash in these frames will be double-hung with (Pullman) sash balances.

**306.—Box Frames.**—All other windows to have box frames for double-hung sash (1½-inch) pulley stiles and outside casings, ¾-inch box casings, ploughed for sub-jambs, 1¾-inch sills (formed as per detail), (1¾-inch) staff head (or 1¼x2-inch beaded brick mould) and ½x¾-inch parting strips. Pulley stiles and parting strips to be of clear hard pine, with pockets to give access to the weights. Hang ¾-inch pendulums in the boxes to separate the weights. Pulley stiles to be ploughed into outside casings.

All frames on rear and sides to have 1½-inch Dutch heads with (3-inch) rise. Frames in front elevation (where shown) to have segment heads inside and out (or finished square on the inside.)

*Box Heads.*—[See Section 284.]

**Sashes and Glass.**—[Same as in Sections 285 and 286.]

*Revolving Sash: Pivoted Sash.*

**307.—Outside Door Frames.**—The frame for front entrance to be made with 1¾-inch paneled pine jamb, rebated and veneered with ½-inch quarter-sawed oak, with 1¾-inch moulded oak staff head. (Transom, side lights, etc.) This frame is no. to be set until the house is plastered.

All other outside door frames to be made from 1½x(8-inch) pine plank, rebated (and reeded) with 1½-inch beaded brick mould; transom bars where shown, worked out of 2½-inch pine plank, wide enough to stop the screen door. Furnish transom sashes 1¾-inch thick, divided into lights as shown and glazed with first quality (single) strength glass. All outside door frames to be doweled to the stone sill by ¾-inch iron dowels, and to be anchored to the walls by ¼x2-inch iron anchors, 8 inches long, screwed to back of jamb, two to each jamb. Frames to be set square and plumb and maintained so.

**308.—Priming of Outside Frames.**—The carpenter is to prime all outside door and window frames (except front entrance frame) *all over*, before they are set, with one good coat of white lead and linseed oil paint. Pulley stiles and parting strips to be primed with boiled linseed oil.

[For priming of sashes see Section 285.]

*Temporary Enclosing.*—[As specified in Section 293, except that for a brick building it is well to enclose it as soon as the roof is on.]

**309.—Furring, Grounds and Corner Beads.**—[The furring and putting on of the grounds, etc., of a brick building is done in the same way as in wooden buildings—see Section 291 for specifications—except that with brick buildings the walls are usually furred on



strapped, in which case the grounds are nailed to the furrings. If the plastering is applied directly to the brick walls it is well in good work to specify for grounds behind the picture moulding, chair rail, etc.] Wall strapping may be specified as follows:

Fur the outside walls for lathing with 1x2-inch spruce strips, 16 inches on centres, straight and plumb and well nailed to the walls. Outside stone walls to be plugged every 16 inches with wooden plugs to receive the furring.

[Where the furring is nailed to wooden plugs it is well to specify 1¼-inch furring for greater stiffness.]

**Mineral Wool Lining.**—Pack with mineral wool between the sheathing and laths of second story bay, from the sole to the plate, also fill in 3 inches thick between the floor beams of bay on top of the matched sheathing. (Walls of bath room, around plumbing pipes, etc., as in Section 292.)

**Preparation for Tiling.**—Prepare the floors of bath room, vestibule and front porch for tiling [as specified in Section 289.]

**Under Flooring.**—[Same as in Section 290—boards to be cut close against all outside walls.]

*Stops for Mice.*—[Around partition studs, as in Section 292; outside walls are usually stopped by plastering between the grounds just above the floor.]

**310.—Cutting and Fitting.**—Cut the floors for registers and hearths as may be required, and cut as required for furnace, steam gas, and plumber's pipe, repairing neatly afterwards. No important timbers to be cut except by approval of the architect.

#### INTERIOR FINISH.

**311.**—All the stock for interior finish of every kind is to be of the very best quality, free from knots or sap, thoroughly seasoned and kiln-dried (and of selected grain). All to be smoothed, scraped and sandpapered by hand before putting up, and at completion such work as is to have a natural finish, to be properly cleaned and all stains and finger marks removed.

No interior finish of any kind is to be taken to the building until the plastering is thoroughly dry, and all hard wood finish and flooring to be taken direct from the drying kiln to the building.

All moulded work to be stuck in accordance with full-size sections.

*Finishing Woods.*—The laundry, kitchen and back hall to be finished in selected *hard pine* (excepting doors, which are to be of white pine). The front hall and vestibule in first story, including the stairway to second story, to be finished in quarter-sawed *white* (red) *oak*.

The parlor to be finished in selected mahogany of a uniform dark color. [See Section 37.]

Dining room to be finished in selected *brown ash*; library and butler's pantry in *cypress*.

The front chamber in second story to be finished in selected *bird's eye maple*; balance of second story to be finished in *white wood* for staining or varnishing in natural color.

All other rooms and closets (except cedar closet) throughout the building are to be finished in *white pine*, to paint.

[Other finishing woods that may be used are cherry, chestnut, beech, birch, butternut, white mahogany and black walnut.

**312.—Doors.**—All doors (except stock doors) are to be paneled and moulded in strict accordance with the scale and detail drawings furnished for the same. All panels to be loose and not glued or nailed. All tenons to have  $\frac{3}{4}$ -inch haunches.

All veneered doors are to have staved-up, thoroughly kiln-dried white pine core, with solid mouldings and  $\frac{1}{4}$ -inch veneering of kiln-dried wood well glued on both sides.

Sliding doors are to have an astragal (he and she) joint in the centre and a  $\frac{5}{8} \times 1\frac{1}{4}$ -inch friction mould on all edges.

The *front doors* are to be (2 inches) thick, veneered both sides with clear quartered white oak, and paneled as shown, with raised panels and mouldings with ( $\frac{1}{4}$ -inch) turned bead let in the moulding.

Vestibule doors to be made to correspond with outside doors, except that the upper panel of each door is to be glazed with polished plate glass with (2-inch) bevel. Front and vestibule doors to have an astragal worked from 2x3-inch oak, glued to the meeting stile of the swinging leaf.

The *kitchen and basement* outside doors to be made of clear well-seasoned white pine,  $1\frac{3}{4}$  inches thick, with (four) plain panels and flush mouldings, or (to be four panel O. G. stock door, first quality,  $1\frac{3}{4}$  inches thick).

All doors opening into first story hall, parlor, dining room, library and second story front chamber, to be  $1\frac{3}{4}$  inches thick, five panels, with raised panels and flush mouldings. All to be veneered to show the same wood as the finish of the rooms.

Doors opening from any of these rooms into closets, are to be veneered both sides with the same kind of wood.

All other doors in second story to be ( $1\frac{1}{2}$ ) inches thick of solid white wood, five panels, with flush mouldings.

*Sash Door.*—The door from laundry to basement hallway to be divided in upper part into (six) lights with wood muntins, and glazed with chipped (ribbed) glass; the glass and glazing to be furnished by the carpenter.

#### *Battened Doors.*

All other doors throughout the house to be four panel (O. G.) stock doors ( $1\frac{3}{4}$  inches) thick, (with plain panels and flush mouldings both sides). The doors opening into kitchen, back hall and laundry are to be first quality, free from sap and knots, and cleaned up for varnishing. All others to be (B) doors.

**313.—Door Frames.**—All inside doors to have  $1\frac{3}{4}$ -inch rebated and beaded frames of solid pine or white wood for the pine and white wood doors, and veneered with  $\frac{1}{2}$ -inch veneer in rooms finished in hard wood. Where the door is between rooms finished in different woods the frame is to show the corresponding wood on each side; or all inside doors to have ( $1\frac{1}{2}$ -inch) frames with  $1\frac{3}{4}$ -inch O. G. stops, glued and braded to the frame. Frames to be blocked solid for the hinges.

Where the door opens between rooms finished with the same wood, the frame is to be solid, but where the adjoining rooms are finished with different woods, the frame is to be veneered with  $\frac{1}{2}$ -inch veneers of the corresponding woods on a  $\frac{7}{8}$ -inch pine core.

All frames to be set square and plumb.

*Thresholds.*—[In some localities called *saddles*.]

All inside doors to have  $\frac{3}{8}$ -inch moulded thresholds of quartered oak for veneered doors and of hard pine elsewhere.

**314.**—**Wainscoting.**—*Ceiled.*—The walls of kitchen, laundry and back hall, from basement to third story to be wainscoted (4 feet) high with ( $\frac{3}{4}$ ×4-inch) centre beaded (three beaded) clear hard pine ceiling, with  $1\frac{1}{4}$ -inch rebated cap and no base.

*Moulded Ceiling.*—The dining room to be wainscoted (3 feet 6 inches high) with  $\frac{3}{8}$ -inch moulded ash ceiling stuck in two patterns as per full-size section, ( $8\frac{1}{2}$ ×1-inch) moulded base, (5-inch) plain necking with  $\frac{5}{8}$ × $1\frac{1}{2}$ -inch moulding just above the wainscoting, and  $1\frac{3}{8}$ × $1\frac{1}{2}$ -inch moulded cap. The bottom of the ceiling to be cut on top of a  $1\frac{1}{4}$ -inch beveled strip, placed back of and  $\frac{3}{8}$ -inch above, the base.

Write a  $\frac{3}{8}$ × $\frac{7}{8}$ -inch O. G. stop against the wall on top of the cap.

*Paneled Wainscoting.*—The front hall and vestibule in first story, stairs from first to second story and the library, to have paneled wainscot (3 feet) high, divided into panels as shown on scale drawings and moulded as per full-size details with raised panels. The framing to be  $\frac{7}{8}$ -inch thick, panels to be put in loose; cap to be moulded with two members and ( $\frac{1}{4}$ -inch) turned bead; 6-inch moulded base.

**315.**—**Bases.**—The parlor to have a skirting (20 inches) high with (5-inch) base, 12-inch dado veneered on a staved-up pine core and two members sur-base to match the window stool and apron, and to intersect with them. Dado to be fastened at the top only.

All rooms and passages in second story (except bath room and back hall) to have (8-inch) moulded base with  $2\frac{1}{2}$ × $\frac{3}{8}$ -inch moulding on top and ( $1\frac{1}{8}$ -inch) sub-base. The base moulding to be rebated over the base and the base to be tongued into sub-base.

All third story rooms and the laundry to have 8-inch O. G. base. Closets to have 7-inch plain base with beveled top.

(Plough all bases at the angles and put them on before the upper floor is laid, and allow  $\frac{1}{2}$ -inch extra below top of floor.)

*Carpet Strip.*—Put ( $\frac{3}{4}$ -inch) quarter round carpet strip around all floors of same wood as base, nailed to the floor and not to the base.

[When the upper floor is butted against the base, carpet strips are not needed ]

**316.**—**Door and Window Trim.**—The doors and windows in principal rooms of first story to have  $5\frac{1}{4}$ -inch moulded casings with  $1\frac{1}{8}$ -inch moulded back band, mitred at the angles. Back band to have  $\frac{3}{8}$ -inch turned and quartered bead moulding. Doors to have (8-inch) moulded plinths

The trim in parlor to have ( $1\frac{1}{4}$ ×10-inch) frieze with moulded cornice with dentils.

All doors and windows in second and third stories to have  $5\frac{1}{2}$ -inch pilaster casings, with turned corner blocks 1 inch thick, and plain  $1\frac{1}{4}$ -inch plinths (10 inches) high. Doors and windows in laundry, kitchen, pantries and back hall to have 5-inch O. G. casings.

Chamber closets to have  $4\frac{1}{2}$ -inch plain casings.

Windows to have  $\frac{3}{8}$ -inch sub-jambs with box casings veneered with  $\frac{3}{8}$ -inch strips in all rooms finished in hard wood;  $1\frac{1}{4}$ -inch moulded stools and 4-inch moulded

aprons. Stop heads  $\frac{1}{2}$ -inch thick of same wood as finish of rooms to come flush with box casings, and in first story to be returned on top of sill.

*Paneled sub-jamb, shutter boxes and paneled backs*, if desired to be specified.

**317.—Inside Shutters.**—Provide and hang (Willer's patent) folding inside blinds for the windows in (parlor, dining room and library)  $1\frac{1}{4}$ -inch in thickness, and of the same wood as finish of rooms. To be made in two sections, upper and lower, and in six folds for all windows 3 feet 6 inches wide and over, and in four folds for all others. The centre folds are to be fitted with rolling slats and the side folds with panels.

*Venetian Blinds.*—Furnish and put up complete in the windows of (second story front chamber), (Wilson's) Venetian blinds with 2-inch maple slats, metal ladders, braided linen cords and bronze fixtures.

*Inside Sliding Blinds.*—[See Section 173.]

*Finish of Blinds.*—All inside shutters, Venetian and sliding blinds are to be finished at the factory to match a finished sample obtained from the painter. All to be rubbed down to a dull gloss.

**318.—Picture Moulding.**—The carpenter is to put a picture mould of same wood as finish of rooms around the principal rooms of first story, and around all chambers. To be  $1\frac{1}{2} \times 2\frac{1}{2}$  inches in first story and  $\frac{3}{4} \times 1\frac{3}{4}$  inches in chambers, all stuck according to detail. The picture mould in the parlor and library to have a  $\frac{1}{2}$ -inch turned and quartered bead mould, and to be placed  $\frac{1}{2}$ -inch below the wood cornice; elsewhere to be placed 18 inches below the ceiling. Picture mouldings to be finished by the painter, except the last coat, before being put up.

[If gilded or ornamented picture mouldings are desired, they had best be included with the decoration.]

**319.—Chair Rail.**—Put a ( $1\frac{1}{4} \times 4\frac{1}{2}$ -inch) moulded ash chair rail around the (dining room). The top to be (3 feet 2 inches) from the floor.

**Angle Beads.**—Put ( $1\frac{3}{4}$ -inch) turned angle beads (4 feet 6 inches long) with turned ornaments at the ends, on all projecting plaster angles, of same wood as finish of rooms.

**Door Stops or Bumpers.**—Put hard wood door stops with inserted rubber in the base or floor where required to stop the doors. Where rooms are trimmed with hard wood they are to match the trim; elsewhere to be of oak or ash.

[These are often included in the hardware specifications and specified by manufacturers name and number.]

**320.—Wooden Cornices, Ceiling Beams, etc.**—The parlor is to have a mahogany cornice extending (10 inches) on the ceiling and (9 inches) on the wall, with dentils, (modillions) and turned beads, as per scale and full-size detail.

The library to have a wooden ceiling with false beams and wooden cornice, all of cypress, the beams intersecting with cornice. The panels between the beams to be filled with  $\frac{3}{4} \times 2\frac{1}{2}$ -inch (double) beaded ceiling, put on diagonally in a portion of the panels and at right angles to the floor beams elsewhere. Put a ( $\frac{3}{8} \times 1$ -inch) bed mould around all panels.

The beams to drop (6 inches) below the panels, to be built up of  $\frac{3}{4}$ -inch stock with paneled soffits and square panels at the intersection. The cornice below the

wall beams to have one row of dentils and one row of ( $\frac{3}{8}$ x1-inch) egg and dart moulding carved by hand (machine).

All wood cornices are to be put together with brads and glue in the best manner, solidly blocked and put together in lengths at the shop. Nails to be concealed as far as possible. All dentils are to be cut on a strip and not put on separately.

**321.—Splicing of Finish, Nailing, etc.**—No splicing of the door or window trim will be allowed, and joints of bases, chair rail, picture mould, etc., must be carefully matched. Brad all moulded finish in the quirk of the mouldings, and set in all finish nails for puttying.

[If the door and window trim is to be put together on the bench, as described in Section 171, it should be so specified here.]

**322.—Finish of Hard Wood Before Putting On.**—This contractor is to finish all of the hard wood trim (and doors) of (hall, parlor, dining room and library) before putting up or hanging, as follows:

[Here specify the kind of finishing material, number of coats, rubbing, etc., desired.]

The final coat to be given by the painter when the carpenter work is finished.

Panels to be finished all but the last coat before they are put in the frame. Paint all hard wood finish one good coat on the back.

**323.—Stairs.**—The front stairs from first to third floors, to be supported on (2x12-inch) well seasoned white pine carriages, carefully shaped to fit the treads and risers, and set level and true in line. Four carriages and a 3x4-inch wall bearer for stairs from first to second floor (Fig. 308), and three carriages from second to third floor. Wall bearer to be securely spiked to wall. Landings to be formed of (2x8-inch) beams. The rough work of the stairs to be firmly put up, and to be self-supporting without the aid of angle posts.

No finished work to be put up until the plastering is dry.

*Curb String Stairs.*—The stairs from first to second floor are to have curb string,  $1\frac{1}{8}$ -inch treads,  $\frac{7}{8}$ -inch risers and  $1\frac{1}{8}$ -inch wall string. Treads to have moulded nosings with ( $\frac{3}{4}$ x $\frac{1}{2}$ -inch) moulding under. The treads are to be ploughed into risers and the risers into under side of treads, and both housed into the wall string [Pennsylvania method, Section 187], and wedged and glued from the wall bearer. The wall string to be rebated on top and capped with a base mould to match the base in hall. The inside face of curb string to be dadoed into the treads and risers. Outside face of string to be paneled as per scale detail with  $1\frac{1}{4}$ -inch frame work, flush (raised) panel mould and (raised) panels, carried around stair well. The curb string to be capped with a (1 $\frac{1}{4}$ x6-inch) piece, moulded and rebated to fit over the string, with a  $\frac{3}{4}$ x1 $\frac{1}{2}$ -inch moulding planted on string under the cap, and turned bead let in, all as per full-size detail. Cut a ( $\frac{7}{8}$ x1 $\frac{3}{8}$ -inch) moulding between the balusters.

The main Newell post to be (6x6-inch in size, built up, to be fluted (paneled) on all four sides, and to have moulded and turned cap with one (carved) member, neck moulding and hand carved rosettes;  $\frac{7}{8}$ -inch moulded base.

All other posts to be (5 inches) square fluted posts, with moulded and turned cap, neck moulding and rosettes in the necking. Put a turned ornament on the bottom of all drop posts.

The rail is to be double moulded out of ( $3\frac{1}{2} \times 3\frac{3}{4}$ -inch stock [see Fig. 310], with ramps and easings at all posts. Sections of rail to be bolted together and to posts.

*Balusters*  $1\frac{1}{8}$  inches square, turned to (three) patterns and set ( $3\frac{1}{2}$  inches) on centres.

Panel under the rake of the first flight and on all soffits with moulded panels about (12 inches) wide to centre of rails. Stiles and rails  $1\frac{1}{8}$  inchesthick, moulded; and plain panels.

### 324.—Open String Stairs.—[Boston method, Section 186.]

The front stairs from second to third floor to have open string, moulded nosings with  $\frac{7}{8}$ -inch cove under, returned at the ends and carried around stair well,  $1\frac{1}{4}$ -inch treads and  $\frac{7}{8}$ -inch risers, the treads ploughed into the risers, and risers into under side of treads, and the base dadoed into both; (1 inch) fancy turned balusters (three) to a tread and around stair well, in same proportion, all dovetailed at the foot and tenoned into under side of rail; ( $3\frac{1}{2} \times 3\frac{1}{2}$ -inch) double moulded hand rail, no ramps,  $4 \times 4$ -inch solid turned posts at the angles with cap and neck mould and half post at upper termination of the rail. The post at foot of stairs to be  $5 \times 5$  inches, boxed, carved and fluted, with moulded cap and base.

Base on wall side of stairs to be rebated and to have a  $2\frac{1}{2} \times \frac{7}{8}$ -inch mould to match the base around hall. All stock to be clear kiln-dried (whitewood), put up in the best and strongest manner. Fur the stairs on the under side for plastering.

**325.—Back Stairs.**—The back stairs from first to second story are to have open string, rounded nosings, with cove under, returned at the ends and carried around stair well,  $\frac{7}{8}$ -inch risers and treads, the treads ploughed into risers, and risers into under side of treads, and both treads and risers to be ploughed for the base on the wall side, (1 inch) plain round balusters (three) to a tread and around stair well in the same proportion, mortised at top and bottom;  $2\frac{1}{2} \times 3\frac{3}{4}$ -inch plain moulded hand rail, and  $3\frac{3}{4} \times 3\frac{3}{4}$ -inch solid turned, chamfered and fluted posts at each angle and at foot with a half post at upper end of rail; all of hard pine throughout.

*Attic Stairs* (built between partitions).—The back stairs from second to third floor are to have  $1\frac{1}{4}$ -inch treads and  $\frac{7}{8}$ -inch risers tongued and grooved together and housed into the wall strings. The treads to have rounded nosing with a cove under. The wall strings to be full  $1\frac{1}{4}$  inches thick, spiked to the studding and rebated on top with base mould to correspond with adjoining base.

The treads, risers and strings to be of clear well seasoned white pine, put up before plastering, wedged and glued from below, and furred on under side with  $2 \times 4$ -inch stock for plastering. Protect the stairs with sheathing paper and boards until the carpenter work is completed. Put up 2-inch round ash hand rail on one side of stairs, secured with iron brackets and with ends returned against plastering.

**Cellar Stairs.**—The cellar stairs are to have (three)  $2 \times 10$ -inch surfaced spruce carriages,  $1\frac{1}{4}$ -inch pine treads, rounded nosing and  $\frac{7}{8}$ -inch risers, nailed to carriages;  $4 \times 4$ -inch turned and chamfered whitewood posts and two  $2 \times 4$ -inch whitewood rails, rounded on top and bead on each side.

*Winter Steps for Front Stoop.*

**326.—Arches, Seats, etc.,** (coming in connection with the front stairs).—The stair builder is to furnish and put up the wooden arches, screen and seat dividing the stair case from main hall, as shown by the scale drawings and full-size details; all of quarter-sawed kiln-dried white oak.

The back of seat to be framed with flush panels and turned bead flush panel mould. Ends of seats to be paneled, moulded and carved as shown. The seat to be stationary, moulded out of 1 $\frac{1}{4}$ -inch plank (or hinged to raise with bronze butts). Riser to be paneled.

*Mantels, Sideboard, Book Cases, Mirrors.*

**327.—Butler's Pantry.**—Fit up the butler's pantry as indicated on the plan, with a counter shelf (2 feet 4 inches) wide and (2 feet 8 inches) high all around. Put (five)  $\frac{7}{8}$ -inch shelves (11 $\frac{1}{2}$  inches) wide above the counter shelf. The top shelf to be (8 feet) above the floor, and to be (14 inches) wide, fitting tightly against back of cornice. Enclose the shelves with 1 $\frac{1}{4}$ -inch sash doors, divided into (four) lights each and glazed with first quality double strength glass. The doors on (south) side to be arranged to slide on brass tracks and fitted with 1 $\frac{3}{4}$ -inch brass wheel anti-friction sheaves. Doors to slide into a rebated frame.

The doors elsewhere are to be hinged at the sides and to have dust-proof joints as per detail drawing. Put a  $\frac{3}{8}$  x 4-inch moulded cornice above all doors, and make 1 $\frac{3}{4}$ -inch rebated frames [see Fig. 315], for the swinging doors.

Provide and place below the counter shelf (six) drawers with lip fronts, with one drawer divided for knives, etc. The remaining space to be divided into cupboards with 1 $\frac{1}{2}$ -inch (O. G.) paneled doors, and one shelf in each cupboard. Fit up the sink with 1 $\frac{1}{2}$ -inch grooved drip board and frame with apron under. All of this work (except the lower shelf) to be of kiln dried (cypress) left clean for a natural finish.

**328.—Kitchen Pantry.**—Fit up the kitchen pantry as indicated on the floor plan in clear white pine, for natural finish. Put up (five) shelves (11 $\frac{1}{2}$  inches) wide above the counter shelf, supported on neat cleats with (three) standards from bottom to top, neatly let in and chamfered.

Fit up (two) barrel cupboards with (O. G.) paneled doors and lifting covers (or fit up two flour bins 18 inches wide, 16 inches deep and pivoted at the bottom).

The remaining space under counter shelf to be filled with one case of three drawers, lip fronts and paneled doors about (16 inches) wide, with one shelf behind. Furnish and put up six pot hooks where directed.

**329.—Dresser.**—Construct and set up the dresser in the kitchen (4 feet 6 inches) wide and (8 feet) high, including cornice, made according to the drawings, of clear kiln-dried (Georgia) pine for a natural finish. To have a counter shelf (2 feet) wide and (2 feet 8 inches) from the floor, with two sliding shelves underneath. The portion above the counter shelf to have four shelves (11 $\frac{1}{2}$  inches) wide, enclosed with three paneled doors, 1 $\frac{1}{2}$  inches thick, hinged at the sides.

Fit up below the counter shelf with three drawers 2 feet long and 20 inches deep with paneled fronts and two 1 $\frac{1}{2}$ -inch paneled doors. The dresser to have paneled ends, solid top with neat cornice, and 1 $\frac{1}{2}$ -inch beaded frame for the doors. Trim the doors and drawers with suitable hardware in (amber) bronze.

**330.—Cedar Closet.**—After the cedar closet is plastered; line the entire inside walls, ceiling, floor and inside of door with ( $\frac{1}{2}$  x 2 $\frac{1}{2}$ -inch) Florida red cedar, tongued and grooved, and blind nailed.

Fit up the closet with drawers and shelves as marked on plan. Counter shelf (20 inches) wide of red cedar. (The drawer frame may be built of white pine, veneered on the outside with cedar, but the drawers are to be entirely of cedar).

**331.—Linen Closet.**—Fit up the linen closet in clear white pine for varnishing. To have a counter shelf 24 inches wide, 3 feet from the floor, and three drawers below (4 feet) long and 22 inches deep, with lip fronts. The bottom of lower drawer to be  $3\frac{1}{2}$  inches above the floor with an O. G. base below.

Put (four) shelves (20 inches) wide above the counter shelf, enclosed with  $1\frac{1}{4}$ -inch paneled and moulded doors (5 feet high), hung at the sides (or arranged to slide on a brass track with brass sheaves). Make  $1\frac{1}{4}$ -inch beaded frame, and finish on top with a  $3\frac{1}{2}$ -inch crown mould.

**332.—Medicine Chest.**—Construct the medicine closet in bath room partition of clear (white wood) for varnishing. The sides, top and bottom to be ( $1\frac{1}{2}$  inches) thick, with bottom projecting (1 inch) beyond the door and moulded (with a moulded apron under).

[Usually the medicine closet comes just above the wainscoting.]

Ceil the back with  $\frac{1}{2} \times 2\frac{1}{2}$ -inch ceiling; put up (three) shelves  $\frac{1}{2}$ -inch thick and hang a  $1\frac{1}{4}$ -inch one panel door in front, glazed with a French plate glass mirror with a thin board behind. Trim the door with neat solid bronze trimmings.

**333.—Bedroom Closets**—All bedroom closets are to have one (12-inch) pine shelf, put up on neat cleats. Put up ( $3\frac{1}{2}$ -inch) beaded strips around all closets for clothes hooks.

The closets from (chambers Nos. 1 and 3) are each to have a case of three drawers as long as the space will permit (16 inches) deep, with paneled fronts and counter shelf above with rounded edge and cove under, and 3-inch O. G. base below the drawers. All the work in chamber and bedroom closets to be of (clear) white pine (for painting).

*Coat Closet.*

*Other Closets.*

*Drawers.*—All drawers are to be dovetailed together, with the bottom grooved into the sides and to run on hard wood strips.

The drawers in (linen and cedar closets) to be fitted with the (Kimball ball-bearing drawer slide).

**334.—Ventilation of Closets.**—Ventilate the closets (in second story) by means of ( $3\frac{1}{2} \times 10$ -inch) tin pipes from each, placed in the partition and run to the air space above the third story with a covering of wire netting over the top.

The vent pipes are to be connected at their lower end with  $8 \times 10$ -inch (white enameled) register faces set in the wall just below the ceiling; to be furnished by the (carpenter).

**335.—Kitchen Sink.**—Make a strong frame to support the kitchen sink. Cover with  $1\frac{1}{4}$ -inch frame of (ash), mortised and tenoned together with grooved drip boards at each end. Put 4-inch apron under. Support the projecting corner of frame with ( $3\frac{1}{2}$ -inch) turned leg of hard pine (or heavy japanned iron bracket); or ceil up under the sink with the same material as the wainscoting with one paneled (battened) door, hung with brass hinges and furnished with a brass catch. Put one 12-inch shelf under the sink. Put two drawers each 4 inches high and 16 inches deep under one end of sink to run on hard wood strips.

*Washtubs.*—Construct and set where shown on plan, stationary washtubs in (two) sections, to be made of clear seasoned white pine  $1\frac{3}{4}$  inches thick, rebated



and put together with white lead joints so as to make tight. Tubs to be 14 inches deep inside, 30 inches long and 22 inches wide across the top and 16 inches at the bottom with front beveling; to be set on a substantial frame, level and true, and to have clamp-flaps to each, hung with heavy brass butts.

**336.—Bath Room Fixtures.**—The plumber will furnish all of the woodwork connected with the bath room fixtures, but the carpenter is to put up the tank and W. C. seat in a neat and substantial manner.

*Plumbing Strips.*—Put up neat beaded strips of same wood as finish of rooms for plumbing pipes where exposed.

Form pockets in the walls and partitions where indicated on plans, and provide with removable (paneled) fronts, let flush into rebated strips each side and secured with brass (japanned) buttons.

*Clothes Chute.*

**337.—Dumb Waiter.**—Line the dumb waiter shaft with  $\frac{3}{4}$ x4-inch hard pine ceiling. Arrange a pocket for the weight with pocket pieces secured with screws. Make paneled doors (2x3 feet) for the openings in kitchen and pantry, and hang with 2-inch steel axle sash pulleys (Silver Lake), sash cord and iron weights carefully balanced. Put a narrow shelf at bottom of doors and provide the doors with suitable hardware.

Construct the car 24x20 inches and 30 inches high, of clear pine (ash),  $\frac{7}{8}$ -inch thick, dovetailed together and fitted with two shelves. Hang the car with New York safety dumb waiter fixtures with best  $\frac{1}{2}$ -inch pliable cotton rope, put up in a substantial manner and left in complete working order. The car to be exactly balanced by an iron weight.

**338.—Upper Flooring.**—Where there is a double floor the upper flooring is not to be laid until the standing finish is all in place.

All under floors to be thoroughly repaired and cleaned before the upper floors are laid.

*Sheathing Paper.*—Lay one thickness of (Manahan's A Brand, double-ply) parchment sheathing between the upper and under flooring throughout first story, and one layer of Cabot's double-ply, asbestos covered deafening quilt between the flooring throughout the second story. Nail  $\frac{3}{8}$ -inch strips on top of the deafening quilt over the floor beams.

Wherever floors have settled so as to be out of level, they are to be furred by strips set over the beams and sized to bring the upper floor to a true level.

*Hard Wood Floors.*—The front hall, first story, is to have an upper floor of quarter-sawed white oak,  $\frac{3}{4}$ x2 $\frac{1}{2}$  inches, matched laid in herring bone pattern, as per detail, with 14-inch border and blind nailed.

The library and dining room to have parquetry floor  $\frac{3}{16}$ -inch thick, laid over white pine flooring.

The kitchen, butler's pantry, laundry and back hall in first and second stories are to have upper floor of 4-inch (2 $\frac{1}{2}$ -inch) first quality, quarter-sawed hard pine flooring, matched and blind nailed and tightly strained.

The dining room and library are to have an upper floor of  $\frac{3}{4}$ x4-inch matched second quality pine boards, blind nailed and tightly strained, and planed to a perfectly level surface to receive the *parquetry flooring*, which will be furnished and laid under another contract.

All other rooms and closets throughout the (first and second stories) to have upper floor of  $\frac{3}{4}$  x 4-inch first and second clear hard pine flooring, matched and blind nailed and tightly strained, or, to have upper floor of  $\frac{3}{4}$  x 6-inch second quality white pine flooring (or first quality spruce flooring), carefully jointed, laid breaking joint every 2 feet, tightly strained and nailed over every bearing with two 8d. floor nails.

All end joints in flooring to be cut over a bearing in every case. Matched flooring to break joint in every course. Make mitred borders around all hearths and registers. All upper floors to be thoroughly kiln-dried, and brought directly from the kiln to the building, and to be kept dry during the transfer.

All hard wood floors, including the hard pine floor in kitchen, butler's pantry, laundry and back hall, to be smoothed and traversed by hand as soon as laid with all plane marks scraped out. Soft wood floors to have all ridges caused by uneven thickness smoothed off, but not traversed.

*Protection.*—The carpenter is to call upon the painter to oil the hard pine floors that are to be traversed as soon as they are smoothed, and is to protect the hard wood floors by two thicknesses of sheathing paper, the under thickness waterproof, properly put down and maintained in good condition until the painter starts filling. The carpenter to be responsible for the condition of these floors until that time.

**339.—Cellar Work.—Partitions.**—Put up board partitions where shown on basement plan, with 2 x 4-inch uprights 3 feet apart, and one horizontal piece cut in between. All to be of good spruce stock, surfaced three sides. Ceil the partitions vertically on one side only, with  $\frac{3}{4}$  x 6-inch good sound matched pine (spruce) boards, surfaced both sides, set in a shoe at the bottom and cut tight against the plastering, floor beams or under floor at the top, as the case may be.

*Coal Bins.*—Build the coal bins with (3 x 4-inch) studs, set 2 feet apart. Ceil on outside to the ceiling with (vertical) matched boards and sheath up (4 feet) on the inside with 1-inch rough sheathing. The openings to bins to be provided with battened doors of matched boards, hung with heavy strap hinges and provided with good strong latch. Inside of the door fit removable slides of  $1\frac{1}{4}$ -inch boards.

Lay the floor in coal bins of 2 x 10-inch spruce planks, spiked to 4 x 4-inch spruce sleepers (or cedar sleepers), 2 feet apart.

*Storeroom.*—Fit up the storeroom in cellar with (four 1 1/2-inch) pine shelves  $\frac{3}{4}$ -inch thick, on two sides of the room. The shelves to be supported on cleats with a  $1\frac{1}{4}$ -inch standard in the centre.

Put up one hanging shelf 16 inches wide and  $1\frac{1}{8}$  inches thick, hung free from the walls.

**340.—Wine Cellar.**—Fit up the wine cellar with  $\frac{3}{4}$ -inch pine shelves 10 inches deep and 9 inches apart, extending from the floor to the ceiling. Nail a  $\frac{3}{4}$  x 4-inch strip to the front edge of the shelves; cut out for the bottles with half round cuts  $1\frac{1}{2}$  inches wide and 4 inches on centres. All shelves in basement to be surfaced both sides and edges.

**Cold Air Box.**—Construct a cold air box from the opening in outside wall to the duct under cellar floor (12 inches by 2 feet) inside, made of 12-inch pine boards, surfaced one side, and 4-inch matched flooring. Provide the box with a slide damper and a door opening into cellar, hung with iron butts and secured with two iron buttons. Construct an air duct 10 x 12 inches from register in hall floor, connected with cold air box below the damper and fitted with a sliding damper.

**Ash and Garbage Box.**—Make in suitable place a strong double box of  $\frac{7}{8}$ -inch match and beaded pine, to contain ash and garbage barrels with division between. Each part to have battened door in front with good lock and two keys for removing barrels and lifting cover on top, hung with galvanized iron (brass) butts and with galvanized (brass) hook and staple fastening.

## HARDWARE.

## [FIRST METHOD.]

**341.**—The contractor for the carpenter work is to allow the sum of \$— for the hardware trimmings of all doors and windows, and of the fittings in cedar closet and butler's pantry, exclusive of the sash cord, weights and pulleys and of tracks and hangers for sliding doors.

This allowance is to cover the net cost to the contractor, and the owner shall be permitted to select the hardware where he chooses, and is to have the benefit of any deduction from the allowance.

The contractor is to furnish the architect with a correct list of the hardware, and is to put it on in a careful and workmanlike manner.

He is also to provide and put on such other hardware as is called for by the plans and specifications.

[Here should follow specifications for hanging double-hung sash and sliding doors, and for cupboard and drawer trimmings, unless previously specified. For hanging sashes and sliding doors, see Sections 344 and 347.]

## HARDWARE.

## [SECOND METHOD.]

**342.**—The contractor is to furnish and put on at the proper time and in a skillful manner, all necessary hardware trimmings and fittings of the kind and quality herein specified. If any necessary hardware is omitted the carpenter is to supply the same to correspond with the hardware in the same room or closet.

All hardware to be put on with screws in finish to match.

**Ornamental Hardware.**—All of the trimming hardware of doors and windows in vestibule, first story hall, parlor, library and dining room to be of (Sargent & Co.'s) goods, of the designs and finishes indicated below, all the various pieces in the same room to have the same ornamentation and finish. Where goods are specified by number, Sargent & Co.'s catalogue is referred to unless otherwise specified.

Hall and vestibule, R N design, sand finish, clouded antique copper.

Parlor, Y design, antique silver finish.

Library, D design, light antique copper finish.

Dining room, R G design, clouded bronze finish.

**Door Hardware.**—**Butts.**—The front doors to be hung with three  $4\frac{1}{2} \times 4\frac{1}{2}$ -inch heavy solid bronze butts to each door. Vestibule door to be hung with three  $4\frac{1}{2} \times 4\frac{1}{2}$ -inch plated butts. All other swing doors opening into or from the hall and the three rooms mentioned, to be hung with two  $4 \times 4$ -inch plated butts. All butts to be loose-pin butts, finished to match the hardware of the room into which the

door swings, and in dining room to have the ornamentation above indicated; the other butts to be plain ball-tipped butts.\*

*Locks, Knobs and Escutcheons.*—The front doors [pair of doors] to be trimmed with cylinder set No. 803K N, double trim. Vestibule door with cylinder set No. 803½K N.†

All other swing doors in the rooms above mentioned, to be trimmed with Sargent's No. 5259P lock, with 2½-inch round knobs and combined escutcheons of the ornamentation and finish above indicated. Face of locks to be finished to match the knobs.

The sliding doors between library and parlor and between library and dining room to be trimmed with Sargent's No. 6964P lock, with two large cup escutcheons of the ornamentation indicated, to each door.

*Flush Bolts, Cupboard Doors, etc.*—The standing leaf of front doors to have two No. 1109K N flush bolts on the face of the door, 12 inches long at the bottom and 18 inches long at the top.

Furnish one No. 9185K N push button for front door frame.

The cupboard doors in dining room to be hung with 2½-inch light loose-pin, ball-tipped solid bronze butts, fitted with cabinet locks and trimmed with cabinet escutcheons No. 891R G.

The drawers below the cupboard to be trimmed with No. 800R G drop handles, two to each of the long drawers and one to each of the short ones.

**343.**—*Window and Shutter Trimmings.*—Trim the double-hung windows in the rooms above mentioned with Fitch bronze metal locks, No. 44 size, finished to match as near as practicable the other hardware of the rooms. Put two flush sash lifts of the ornamentation indicated on each lower sash.

*French windows* to be hung with 3x3-inch light loose-pin, ball-tipped solid bronze butts and trimmed with two mortise flush bolts on the standing leaf, and Sargent's No. 5089P lock with lever handle and combined escutcheon on the inside only. Bolts, levers, handles and escutcheons to be of the same ornamentation and finish as the other hardware of the rooms, and the butts to be finished to match, or, trim with Yale & Towne Cremorne bolt, No. 893 plain, or Corbin's espagniolette bar, No. 069½, or a flush double extension bolt, finished to match the other hardware of the room; one bolt or bar to each window.

*Shutters.*—Hang the shutters in the rooms above mentioned with 1½-inch beveled shutter flaps and three-fold pocket hinges, bronze plated and finished to match the other hardware of the rooms.

Trim the shutters with Sargent's shutter bars and knobs of the ornamentation and finish specified above.

**344.**—*Plain Hardware †—Door Trimmings.—Sliding Doors.*—All sliding doors (including those from the library), to be hung with the Coburn trolley track No. 2 and Coburn roller bearing parlor door hangers, securely put up and carefully adjusted.

\* Butts are not usually ornamented to match the other hardware, but are included in a few designs

† These sets include lock, knobs and escutcheons

‡ The hardware specified under this heading for first and second stories is of very good quality, and probably more durable than that specified under Ornamental Hardware.

*Double-Action Doors.*—The double-action door between butler's pantry and kitchen to be hung with two Bommer 7-inch double-action hinges, japanned (or with one Chicago double-action hinge and one blank, both japanned). This door to be trimmed with two plain wrought bronze push plates (3x11 inches), with beveled edge (and Yale "Vulcan" dead lock, No. 2230B, with two No. 5812B key plates).

[In restaurants, hotels, etc., double-action doors between the kitchen or serving room or serving room and dining room should be trimmed with kick-plates, but in private residences they are seldom used.]

*Balance of First Story.*—All other doors in first story to be hung with two 4x4-inch (Stanley wrought steel) loose-pin butts, ball-tipped (and fitted with steel washers). Butts on doors opening into back hall and lavatory to be Bower-Barffed. All others to be japan finish. The outside door of back hall to be fitted with Yale three-bolt "Vulcan" lock, No. 2535FX80. Balance of doors to be fitted with Yale "Vulcan" lock, No. 2430FX80, where showing in hall and lavatory, and No. 2430B elsewhere. Put a No. 22 Yale rim night latch on outside door of kitchen.

Trim the doors showing in back hall and lavatory with Yale knobs, No. 056FX80 and No. 6409 escutcheon, same finish. Outside door to have same knob both sides with No. 7411FX80 escutcheon on outside and No. 7414FX80 escutcheon with No. 5 thumb knob on inside.

Balance of doors in first story to be trimmed with Yale jet knob, No. 45, and No. 5309 escutcheon in natural bronze.

**Second Story Doors.**—All second story doors to be hung with two (Stanley wrought steel) 4x4-inch loose-pin butts, ball-tipped, bronze plated and polished, natural finish.

All chamber doors opening from hall or passage to be fitted with Yale "Vulcan" three-bolt chamber door lock, No. 2535B. Doors between chambers to be fitted with "Vulcan" communicating door latch, No. 2400B. All other doors in second story to be fitted with Yale "Junior" lock, No. 3310B.

Trim all of these doors with No. 52 Yale bronze knobs and No. 7409 escutcheons for "Junior" locks; No. 7411 escutcheons for outside of chamber doors, and No. 7414 escutcheon with No. 5 thumb knob for inside of doors with three-bolt locks, and No. 7432 escutcheons with No. 5 thumb knob for communicating latches, all in natural finish.

Closet doors to have the same trim on both sides.

**345.—Third Story Doors.**—All third story doors to be hung with 4x4-inch loose-pin (or loose-joint) Boston finish, (bronze plated) iron butts, ball-tipped (with steel washers).

Fit all of the doors in this story with Sargent & Co.'s No. 5244P lock (or Rus-sel & Erwin's No. 390 lock, or P. & F. Corbin's No. 785B lock\*), and trim with 2½-inch plain bronze metal spun knobs and wrought bronze escutcheons with rounded edge, 1¾x5¾-inch or larger, all in natural finish.

**Basement Doors.**—The panel doors in basement to be hung with 4x4-inch japanned iron butts (with steel washers), fitted with Sargent & Co.'s lock, No. 5234P, and trimmed with mineral knobs, with japanned roses and keyhole plates.

\* These locks are all good one-tumbler locks, and of about the same grade; much cheaper locks are often used.

The battened doors to be hung with 6-inch Stanley corrugated T-hinges 170. 961, fitted with Russell & Erwin No. 3806 rim lock, and trimmed with mineral knobs, with japanned rose and keyhole plate.

Outside basement door to be fitted with 4-inch wrought steel japanned barrel bolt with bent staple.

The doors to wine cellar and store closet to be fitted with Yale mortise dead locks, No. 304, and trimmed with japanned iron pull.

**346. — Transoms.**—The transoms over outside doors of back hall, kitchen and on rear balcony to be hung at the bottom with 3-inch narrow butts, japanned in hall, and bronze plated elsewhere and fitted with Yale transom lifters, No. S353. Bower-Barff finish in hall and bronze plated elsewhere.

All transoms over inside doors to be pivoted at the sides with  $1\frac{3}{4} \times 2\frac{5}{8}$ -inch open socket sash centres (Fig 410), bronze plated and fitted with Payson's "solid grip" transom lifters, No. 203, bronze plated\* (or Yale No. S353, or Russell & Erwin No. 130 $\frac{1}{2}$ , 3 foot bronze plated), (or finished to match the other hardware of the room).

**347. — Window Hardware.**—*Double-Hung Windows.*—The windows in second story bay to be hung with Pullman side pattern balances, No. 16, (or Pullman tandem side pattern balances No. 1016)

All sash in box frames and glazed with plate glass, to be hung with 2 $\frac{1}{2}$ -inch Norris bronze metal face, noiseless pulleys, No. 314A, Samson spot cord, No. 8, and iron weights carefully balanced, or to be hung with Queen overhead tape pulleys, 2 $\frac{1}{2}$ -inch wheel, electro-bronze face, No. 16, Queen aluminum-bronze sash ribbon and iron weights carefully balanced, or to be hung with Gardner anti-friction square end pulleys, 2 $\frac{1}{2}$ -inch wheel, bronze face, Gardner No. 4 sash ribbon, and iron weights carefully adjusted. Face of pulleys in hall, parlor, dining room and library to be finished to match the other hardware of the room. Should any of the frames be too short for iron weights to work properly, Raymond's compressed lead sash weights are to be used instead of the iron weights.

All other double-hung windows to be hung with 2-inch noiseless pulleys with turned iron wheel and square bronze plated (amber bronze) front; Samson spot cord (Silver Lake sash cord), No. 8 size for all weights of 15 pounds and over and No. 7 for lesser weights, and iron weights carefully adjusted.

*Sash Locks and Lifts.*—Trim the sashes throughout the second story with Ives cast bronze sash lock, No. 534 (Fitch sash locks, No. 24), and plain wrought (cast) bronze flush sash lifts, two on each lower sash, 30 inches wide and over, and one on all others. The lower sash of bay windows [see Section 242] to have combined sash lift and lock, Russell & Erwin, No. 0776. Put a Willer plain bronze sash lift on each upper sash about 12 inches above the meeting rail.

One window in each second story chamber to be fitted with a No. 1405 Corbin bronze metal sash bolt, with three strikes. [For ventilation.]

All double-hung sash in third story and in rear portion of first story, to be trimmed with Ives No. 150 stamped bronze sash lock (Fitch lock, No. 22), and wrought bronze metal hook sash lifts, two to each lower sash, 30 inches wide and over and one on all others.

(Put Willer sash lift or sash sockets on upper sash).

\* The cheapest finish is "bronzed iron."

*Stop Beads.*—All stop beads of double-hung windows in first and second stories to be secured with (Taplin's) or (Climax) window stop adjuster finished to match the other hardware of the room and spaced about 12 inches apart.

*Doors Under Windows.*—Where there are doors below the sash they are to be hung with 3x3-inch light loose-pin solid bronze butts, ball-tipped. Provide for such doors one 4-inch bronze metal square cased bolt (of 4-inch bronze metal flush bolt) to go into the sill, one 2-inch real bronze cupboard turn at centre, and a flush lift and lock combined in bronze metal (Yale & Towne, No. 1349L), to go on the lower sash.

**348.—Casement Windows.**—The casement windows in second story to be hung with 3x3-inch light loose-pin, solid bronze butts, ball-tipped and fitted with (Russell & Erwin) casement adjusters (No. 20—15-inch) or Corbin casement fastener, No. 02161½ (Russell & Erwin, No. 11½) or with Yale & Towne Cremorne bolt, No. 893, plain natural bronze finish.

*Pivoted Sash.*—Sash pivoted top and bottom to be fitted with Yale sash centres, No. 1335, and Yale sash adjusters, No. 1396—15-inch.

**349.—Cupboard Trimmings.**—The swing sash doors in butler's pantry to be fitted with (Stanley) 2½-inch loose-pin light narrow butts, ball-tipped, bronze plated and polished, two (three) to a door; 1¾-inch bronze metal cupboard turns and Yale standard mortise dead lock, No. 910 (or Yale cupboard lock, No. 5502). The sliding doors to be fitted with one bronze metal flush pull, 1¼x3 inches, on each door (and Yale lock No. 542).

The cupboard doors below counter shelf to be fitted with (Stanley) 2-inch loose-pin, light narrow butts, ball-tipped, polished and bronzed, and 2-inch bronze cupboard turns, anti-friction strike. The standing leaf of double doors to have bronze elbow catch on the back.

The sash and cupboard doors in cedar closet and linen closet to be trimmed as specified for the doors in butler's pantry, without the lock. All to be in natural bronze finish.

Cupboard doors in kitchen pantry to be hung with 2-inch narrow japanned butts, and trimmed with 2-inch bronze plated (Boston finish) cupboard catches, with elbow catch for standing leaf.

*Medicine Closet.*—Trim the door of medicine closet with 2¼-inch light solid bronze butts, ball-tipped and bronze lever catch (Corbin, No. 329).

**Drawers.**—The drawers in butler's pantry, cedar closet and linen closet to be fitted with 1½x3½-inch solid bronze drawer pulls, Corbin pattern, No. 2106, two to each drawer, 24 inches long or over, and one on the others.

Two drawers in butler's pantry to be fitted with Yale "Paracentric" locks, No. 5552. All other drawers to be fitted with 4 inch square rim, figured iron drawer pulls, No. 3 finish, two to each drawer, 28 inches long and over, and one on the others.

**Clothes Hooks.**—The chamber closets and closet off back hall to be fitted with japanned double cast iron clothes hooks, 9 inches apart, all around the closet.

Closet under front stairs to have twelve bronze clothes hooks (similar to Yale & Towne hook, No. 1601), and four coat and hat hooks (similar to Yale & Towne hook, No. 1603).

[The author usually specifies the hardware for outside blinds, storm windows, screens, etc., in connection with the fixtures (see Sections 285 and 287), but if not there specified they should be specified here.]

### GRAVEL ROOF.

(To be included in Carpenters' Contract.)

#### [WESTERN METHOD]

**350.**—Cover the flat roof with five ply gravel roofing, put on in the best manner. The first layer to be of heavy dry felt, put on with 2-inch lap. The other four layers to be of ——— brand saturated felt, (25) pounds to the square. Put on in courses parallel with the eaves, each layer lapping the one below 27 inches, so that the roof will be five layers in thickness over all its parts, and to be well mopped for a distance of 9 inches from the edge with hot pitch. Secure the felt to the roof by 3d. nails with tin discs, driven in rows 10 feet apart and 12 inches apart in the rows.\* Cover the entire surface of felt, flashings and back of fire walls with a continuous and even coating of straight run coal tar pitch and cover the same immediately with a sufficient body of well-screened gravel. If the roof is laid in cold weather the gravel is to be applied hot.

*Flashing.*—Finish the roofing against fire walls, chimneys, scuttle and skylight by turning the felt up 4 inches against the wall. Over this lay an 8-inch strip of felt with half its width on the roof. Fasten the upper edge of the strip and the several layers of felt to the wall by laths or wooden strips securely nailed, and press the strip of felt into the angle of the wall and cement to the roof with hot pitch. Nail the lower edge of the strip to the roof every 4 or 5 inches. Take especial care in fitting around the angles of chimneys and skylights. Extend the felt 6 inches up on pitch roof, and secure every 4 inches with 3d. nails with tin washers.

#### [EASTERN METHOD]

**351.**—[In the New England States the saturated felt is often put on one layer at a time, in which case the first paragraph above should read as follows:]

Cover the flat roof with one layer of heavy dry felt and four layers of saturated felt (weighing 25 pounds to the square), lapped 3 inches and the edges cemented with hot pitch. Each layer to be laid separately, and the last two layers to be laid in hot pitch. Secure the last layer to the roof, at the laps, by 3d. nails with tin washers, spaced 30 inches apart. Pitching and gravel same as above.

[Still another method of applying the saturated felt is to apply three layers as in the Western method, each layer lapping 24 inches, then cover with pitch and apply one or two more layers of felt separately in hot pitch. This makes a very good and durable roof.

**352.**—*Flashings.*—(Metal).—Turn the felt up against fire walls, chimneys, skylights, and rising parts 4 inches, and flash with strips of zinc (Merchant's or

\* This is not always done.



Taylor's old style I. C. tin), turned up 5 inches against the walls and extended 3 inches on the roof, with the lower edge secured by 3d. nails, spaced 1 inch apart. Cover this flashing with 4-pound lead or 14 ounce copper let into joints in the brickwork at least 1 inch and secured by wooden plugs.

Counter flashing to come within 2 inches of the roof surface, and on the scuttles and skylights the counter flashing to be turned over top of curb.

Solder the joints in the under flashing in a substantial manner.

The eave stops will be formed on the gutter, which will be put up by the metal workers.

The entire job to be done in a thorough and workmanlike manner, and to be accompanied by a written agreement or bond to repair all leaks within the term of three years from completion without cost to the owner.

### SLATE ROOFING.

(To be included in the Carpenters' Contract).

**353.**—Cover all boarding that is to be slated with tarred felt, weighing 20 pounds to the square (Neponset black building paper), well overlapped previous to slating. Cover all inclinations of the (front) roof, also roofs and cheeks of dormers with the best quality of Brownville, Me., (Peach Bottom, No. 1 Bangor) blue black slate, (or Granville, N. Y., red slate), 8x16 inches in size on dormers, and 10x20 inches on the roof.

The slates are to be laid with a double lap and (3), (2½) or (2-inch) head cover, and secured with two tinned or galvanized nails to each slate. All slates to have smooth split surfaces, out of wind, with edges and tails cut or sawn straight and square. All slates more than  $\frac{3}{16}$ -inch thick are to have the nail holes drilled and counter-sunk. The eaves and ridge courses to be double. Slates to be cut close to the hip and ridge poles, and to a straight line in the valleys.

*Rendering.\**—All slates for a distance of 2 feet each side of valleys and 1 foot each side of hips, chimneys and rising parts the last two courses at ridges and the first four courses at the eaves, to be thoroughly rendered with (Purcell's) elastic cement (or slaters' cement).

All the slates on the flat slope over ——— are to be rendered at the joints over the nail holes and an inch under the tail with the same cement, using 40 pounds to each 100 square feet.

**354.**—**Flashings.**—Furnish material for and put on the following flashing and valley linings:

*Valleys.*—Line the valleys with strips of (tin, 14 ounce zinc, 16 ounce copper), 20 inches (18 inches) wide, with end joints locked and soldered, and the edges nailed to the roof with galvanized nails every 12 inches.

[If tin lining is used, it should be painted on underside.]

Flash in the best manner around all (scuttles, skylights, dormers and masonry) coming in connection with the roof with (Merchant's or Taylor's old style IX tin, 14 ounce zinc or 16 ounce copper) 7 inches wide, turned up 3½ inches.

\* A great deal of slate roofing is done without any rendering at all. For good work, however, the slates at hips, ridges and valleys should be bedded in elastic or slaters' cement, and if the roof is less than "one-third" pitch, all of the slates should be rendered as in second paragraph.

*Aprons.*—Put on aprons of the same material 10 inches wide, at the top of lower sections of roof coming against walls, or roofs of a different pitch. Put apron under dormer window sills, nailed to inside of sill and extended 3 inches on the slates.

*Counter-flash* all under flashings against masonry with (4 or 3 pound sheet lead or 16 ounce copper), worked 2 inches into the joints of the masonry, cemented in with slaters' (Purcell's elastic) cement and brought down to within  $\frac{1}{2}$ -inch of the slate. Counter-flashing to be stepped on the rakes.

*Cresting Finials and Hip Rolls.*—These will be furnished and put on by the metal worker.

#### SPECIFICATIONS FOR HEAVY FRAMING.

**355.**—The following is offered as a guide when specifying heavy framing, although as buildings of this class vary so much in their construction, only the common features of construction will be mentioned. All special features should be carefully shown by scale drawings and details, and further described in the specifications.

The building hereinafter considered is a three-story brick building with the floors of mill construction, wooden posts and a trussed roof over third story. The roof has a pitch each side of 5 inches to the foot, and is to be covered with roll or standing seam steel roofing. At one corner of the building is an octagon tower, surmounted with an open belfry. All iron work is to be included in the carpenters' contract.

**Specifications for the Carpenters' Work.—General Conditions.**—[As in Section 273.]

Furnish all timbers, furring stock, iron plates, steel beams, hangers, joint bolts, truss rods and all iron work and hardware of every sort for the floors, roofs, trusses, belfry, and where necessary and required throughout the entire work, as shown or may be shown, by the working drawings and the specifications thereon written: frame, raise and fix in position the several parts of the work.

All iron beams to be painted one good coat of red lead and linseed oil ("Superior Graphite Paint"\*) before they are set in position, all hangers, post caps, anchors, etc., to be dipped in the same.

**356.—Timber.**—*Hard Pine.*—All posts, planks for girders, floor beams, truss timbers and purlines, and all special timbers marked H. P. on framing plans, to be of the best quality straight grained long-leaf Georgia pine, thoroughly seasoned, sawed full and square to dimensions (and surfaced four sides, the timbers when surfaced to be within  $\frac{3}{8}$ -inch of the sizes marked on framing plans).

*Spruce.*—All other framing timber, including rafters, to be of the best quality, straight grained (Eastern) spruce, full and square to the dimensions marked on the drawings.

All timbers to be framed and put together in a skillful manner, according to the plans, sections and details and these specifications.

\* Prepared by the Detroit Graphite Manufacturing Co.

The posts in first and second story to have 1x1-inch chamfer on the angles, stopped 12 inches above the floor and 4 inches below the iron cap. All other timbers to have square edges.

The basement posts to rest on cast iron base plates, made as per detail drawing and bedded in cement mortar by the stone mason. The carpenter is to see that they are set true and level.

Furnish cast iron caps (or Van Dorn steel post caps) for all posts, and bolt them to the posts and girders as shown. All second and third story posts to rest on the cap of the post below and not on the girder.

Furnish the steel beams for basement girders of the sizes and weights indicated, and fit 3x14-inch planks to the sides of the beams and secure by  $\frac{3}{4}$ -inch bolts, 20 inches on centres.

Girders supporting second and third floors to be of solid timbers.

The ends of all girders to rest in Van Dorn steel wall hangers (Duplex wall hangers or Goetz No. 4 box anchors) of the size and thickness shown.

All floor beams are to be framed flush on top with the girders, the wall end to be cut with 4-inch bevel and to rest on 8x8x $\frac{1}{4}$ -inch cast iron plates with lugs, as per detail drawing (Fig. 499). Inner ends to rest in Van Dorn steel joist hangers (Duplex joist hangers or Goetz joist hangers). If in Goetz or Van Dorn hangers, to be secured to the hangers by 6d. spikes driven into the bottom through the hanger. If in Duplex hangers, each pair of hangers to be bolted together through the girder.

Frame around staircase opening with headers and trimmers of the size shown, hung in (the same kind) of hangers. The tail beams to be secured as specified above; header to be secured to trimmers by  $\frac{3}{4}$ -inch round iron dogs, 16 inches long, turned down 2 inches into the wood. Frame 3-inch hard pine plank of same depth as beams between the floor beams against the side walls to receive the under floor; these pieces to be hung in 3-inch Duplex (Goetz) joist hangers.

*Trusses.*—Construct the roof trusses as shown by scale and detail drawings. All rods to be of medium steel, upset without welding, and to have head on one end and square nut on the other. Put in all bolts, nuts, plates and washers shown on the drawings, and fit the timbers to make tight joints with even bearings. Raise and fix them in position in the most careful manner to guard against accidents. Crown the trusses 1 $\frac{1}{2}$ -inch in the centre.

The trusses to rest on cast iron plates, made as per detail drawings and carefully bedded in cement on the brickwork. The trusses to be braced from the walls by wooden braces bolted to truss, and to 6x10-inch uprights against wall, resting on stone corbels. Bolt these uprights to the wall by three  $\frac{3}{4}$ -inch bolts 22 inches long, with 6x6x $\frac{1}{2}$ -inch plate washer on wall end.

Frame the purlines as shown on section and roof plan. The two outer rows to be supported from the trusses with 6x8-inch posts, with 6x8x30-inch bolsters. The bolsters to be secured to top of posts by two  $\frac{3}{4}$ x12-inch square drift bolts, driven in  $\frac{3}{4}$ -inch round holes, and to be bolted to the purlines with one  $\frac{3}{4}$ -inch bolt in each end. Secure the bottom of posts and brace the posts from the trusses as shown; also brace the purlines from the posts by 6x6-inch braces, gained into posts and purline  $\frac{1}{2}$ -inch and secured by  $\frac{3}{4}$ x8-inch lag screws.

The other purlines to be hung from the top chord of the trusses by 3 $\frac{1}{2}$ x $\frac{3}{4}$ -inch double stirrup irons and to be tied together by  $\frac{3}{4}$ -inch round iron dogs, 32 inches long turned down into the timber 1 $\frac{1}{2}$  inches.

Tie the ends of all purlines to the walls with  $\frac{3}{4}$ -inch iron anchors, passing through the wall with 5-inch star washer (ornamental wrought iron washer) and nut on the outer end, and flattened on inner end and spiked to side of purline by three 20d. spikes.

Bolt a wall plate on side walls of two 2x12-inch hard pine planks, laid so as to break joints and to form a continuous tie from end to end (or around the building, if a hip roof). The plate to be secured to wall by  $\frac{3}{4}$ -inch ( $\frac{7}{8}$ -inch) bolts, 20 inches long, with 4x4x $\frac{1}{4}$ -inch plate washer on lower end, and spaced (6 feet) apart. Bolt a 2x12-inch plank on top of gable walls with  $\frac{3}{4}$ -inch bolts and 6-inch washers, 8 feet apart on the rake. Top of plank to be on line with top of rafters.

Frame the rafters on plate and purlines as shown by section drawing, and secure by 40d. spikes. Ends of rafters where they lap to be spiked together. Outer ends of rafters to project (20 inches) beyond the plate and to be cut for cornice as shown.

**357.**—Frame the belfry as per framing plans and as herein indicated. Bolt a plate to the walls formed of two 2x12-inch hard pine planks, lapping at the angles and secured to the brickwork at each angle by  $\frac{3}{4}$ -inch bolts, 5 feet long, and at the centre of each side by a  $\frac{3}{4}$ -inch bolt, 30 inches long. Bolts to have 6x6x $\frac{1}{4}$ -inch washers on lower end.

Turn the belfry posts from 10x10-inch cypress (16 feet long). The posts to rest on the wall plate and to be secured to it by 2 $\frac{1}{2}$ x $\frac{3}{4}$ -inch angle straps, bolted to the plate and to each side of the posts by  $\frac{3}{4}$ -inch bolts. The bolt through post to be 12 inches above the plate.

Cut 4x10-inch timbers between the posts at the height shown, and secure to the posts by 40d. spikes and one  $\frac{1}{2}$ x6-inch lag screw in each end of each stick. Brace from posts to plate and fill in between the plate and 4x10-inch timber with 2x6-inch studding (20 inches) on centres.

Bolt a 4x10-inch plate, halved at the angles, to the top of posts by  $\frac{3}{4}$ -inch joint bolts, 16 inches long, one bolt in each post. Fill in between this plate and the roof plate with 6x6-inch corner posts, 2x6-inch studding and 2x6-inch braces, as shown. The roof plate to be tied to the posts and the posts to the lower plate by 1 $\frac{1}{2}$ x $\frac{1}{4}$ -inch iron straps, 12 inches long, with two 60d. spikes in each end.

Frame the roof of belfry as shown by framing plans and sections, the hips to be cut against an 8-inch octagon pole at the centre, carried down and spiked to the ceiling joists. Form a level ceiling with 2x6-inch joists, 20 inches on centres, spiked to the plate and to the rafters.

*Lookouts.*—Furnish plank lookouts and have the mason build into gable walls 22 inches on centres, and set true in line for the cornice and belt.

**358.**—**Under Floors.**—Lay an under floor throughout the first, second and third stories of (3-inch) spruce (native pine) planks, not over 9 inches wide, dressed on one side to a uniform thickness of not less than 2 $\frac{3}{4}$  inches and grooved on both edges for hard pine splines  $\frac{3}{4}$ x1 $\frac{1}{2}$  inches. The planks to be laid diagonally on the beams, blind nailed over every bearing with 10d nails before the spline is driven in, and all end joints to be cut over centre of beams or close against the wall or flush with beams at opening.

*Partitions.*—The partitions will be built of 2-inch steel channels, with expanded metal on both sides, put up under another contract. The carpenter is to cut a 2x3-inch sole piece between the studding and spike to under floor, set up a 2x2-inch

rough frame around the door and window openings and secure to the steel studding by screws. Also furnish 2x2-inch wood furring blocks as may be necessary to secure the finish; these blocks to be attached to the partition by the contractor therefor.

[Windows, wood lintels, etc., as for any brick building.]

#### STORE FRONTS.

**359.**—Construct the store front as shown on the scale and detail drawings, all exposed woodwork to be of clear white pine (quartered white oak, cypress, redwood or whitewood).

The sash are to be  $2\frac{1}{4}$  inches thick, moulded and rebated for the glass and properly secured. Sill to be  $2\frac{3}{4}$  inches thick with outer edge moulded as per full-size section and bored for ventilation. Transom bar moulded out of (3x4-inch) stock with one row of dentils. Door posts to be worked out of solid timber\* (5x5-inch) rebated for the door and transom and beaded on outer edge. Transom sash to be hung at the top and fitted with transom lifters as specified elsewhere

The doors are to be ( $2\frac{1}{4}$  inches) thick (veneered with quarter-sawed oak on a staved-up pine core), made in the best manner of kiln-dried stock, divided into panels as shown, with raised panels at the bottom and raised (flush) panel mould around both wood and glass panels.

Form the moulded panels below the sill and finish with a  $1\frac{1}{4}$ -inch moulded base, scribed at the bottom, or make  $2\frac{1}{4}$ -inch rebated plank frame for basement sash below the main sill, with  $1\frac{3}{4}$  inch rebated sill (grooved for back of iron sidewalk), and break a  $\frac{3}{4}$ x $\frac{7}{8}$ -inch moulding around the frame. Sash to be ( $1\frac{3}{4}$  inches) thick, divided into lights as shown, hung at the top with 3-inch heavy narrow butts, japanned and provided with  $2\frac{1}{2}$ -inch brass cupboard catch at the bottom, and galvanized hook and eye to keep them open. Cover the opening with wire guard made of No. 11 wire,  $1\frac{1}{4}$ -inch mesh, with  $\frac{3}{8}$ -inch round iron frame, all painted with black varnish.

Form a false beam above the sash around entrance and form the ceiling of entrance with ( $\frac{7}{8}$ x $2\frac{1}{2}$ -inch) beaded ceiling with  $\frac{7}{8}$ x $2\frac{1}{2}$ -inch bed mould.

Form the platforms inside of  $\frac{7}{8}$ x $2\frac{1}{2}$ -inch ( $\frac{1}{4}$ x4-inch) tongued and grooved quartered white oak (maple, hard pine) flooring, blind nailed to (2x4-inch) joists, set 16 inches on centres, and carefully smoothed and scraped. Form a moulded nosing on inside with  $\frac{7}{8}$ x $3\frac{1}{2}$ -inch moulded apron under, and ceil (or form moulded panels) from the apron to the floor.

*Glass.*—The small sash to light basement to be glazed with first quality double strength glass, set in putty. All other glass in the store front, including door lights, to be of American polished plate glass, secured in place with a stop bead (screwed on with nickel-plated screws).

**360.**—If the store front is to be constructed as in Sections *D*, *E* and *F*, Fig. 118, it should be specified as follows:

Construct the frame for store front as shown by the scale and detail drawings. The angle posts, transoms and division bars to be worked out of solid clear straight grained, well seasoned white pine or redwood, moulded as per detail and rebated

\* If store front is finished in hard wood, posts should be of pine, veneered with  $\frac{1}{4}$ -inch stuff.

for the glass. Sill to be moulded out of 3x8-inch (redwood) and strongly supported. Door posts to be worked out of 4x4-inch whitewood, rebated for the door and transom and beaded on outer edge.

Cover the outside of angle and division bars with oxidized copper sash bars (copper sash bars, nickel plated) of the size and shape indicated on the drawings and formed over a white pine (redwood) core. The vertical bars to cut between the sill and transom and between transom and soffit of window. Put up 1 $\frac{1}{8}$ -inch plank at top and sides, secured to the ironwork by machine screws, and veneer with  $\frac{1}{2}$ -inch (whitewood). Cover on outside with 1x $\frac{3}{4}$ -inch oxidized copper sash bar, made to cope with the vertical bars and to fit against the iron soffit and columns.

All metal sash bars to be put on with (2 $\frac{1}{2}$ -inch) round-headed screws, about 16 inches apart, finished to match the sash bars.

[Rest or window, doors, glass, etc., same as specified above.

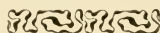

## APPENDIX A.

### PATENTED DEVICES USED IN CONNECTION WITH CARPENTERS' WORK.

#### ROLLING OR COILING PARTITIONS.

It is very often desirable to unite two rooms by a large opening so as to practically make one room of the two, or to divide a given space by means of movable partitions so as to form several separate rooms or one large one at will. To close these large openings coiling partitions or flexible doors have proved as a rule to be the most practicable device, and the architect should therefore be acquainted with the manner in which these coiling partitions operate, the best way of providing for them and their limitations.

Coiling partitions operate in two ways, *A* by coiling about a horizontal shaft placed above the opening, and *B* by coiling about a vertical shaft placed at the side of the opening; the former will be hereinafter referred to as *horizontal partitions* and the latter as *vertical partitions*.

**Horizontal Coiling Partitions.**—The limitations of these partitions are that the opening for a single coil shall not exceed 20 feet in height or 15 feet in width.

If the height is over 10 feet it will be better to keep the width down by sub-divisions to 8 or 10 feet as the smaller the door or partition, the less will be the force required to operate it. For churches and schools a height and width of from 10 to 12 feet will be found to give the best results as a rule.

Where a greater width than 14 feet is desired, the opening may be divided by permanent posts, or by guideways put up so that they can be readily removed when the partition is raised. At the sides, horizontal coiling partitions require only a grooved guideway about 3 inches wide, but at the top a box of considerable size is required to enclose the coil.

The best method of putting up the partition will depend somewhat upon the structural conditions of the building.

Where there is but a single opening in a 6 or 8-inch partition, the method shown in Fig. 501 is the simplest and gives a neat appear-

ance. Brackets for receiving the shaft are screwed to the face of the jamb and the coil is encased by narrow ceiling as shown. If the height of the opening will not permit of this arrangement, the brackets may be placed on the face of the partition so that the coil will be above the opening, as shown in Fig. 502.

When there are several openings side by side, or at right angles to each other, as in the plan, Fig. 503, it will be better to make the posts forming the permanent partition large enough, so that the box containing the coil will go between them. A favorite method for finishing such partitions is shown in Fig. 504, which represents the elevation of a portion of the partition in a room 14 feet high.

The casing of the large post is made deep enough to receive the paneled transom enclosing the coil, and transom sashes are placed

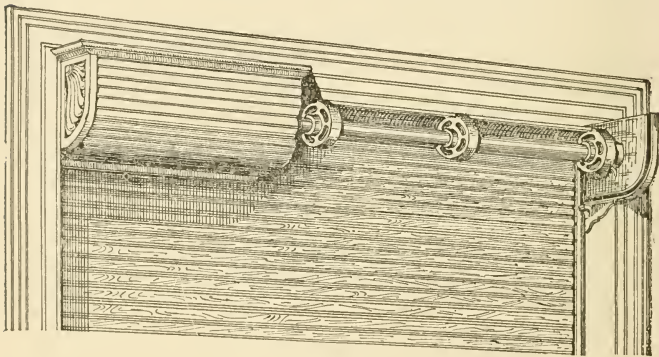

Fig. 501.

above. At *P* is shown a removable post or guideway, which is secured at top and bottom by flush bolts so as to be quickly removed when the coiling partitions or doors are raised.

Where such removable posts are used, it is necessary to place a plank or iron bracket in the coil box directly over the post to receive the end of the shafts on either side.

This block or bearing may be hung from the ceiling by iron bars enclosed in the division between the transom sash, and where the transom is over 8 feet long it should be supported in the same way. Removable posts may also be used when the coil is placed and enclosed, as in Figs. 501 and 502, a bracket being placed directly over the removable post.



Fig. 505 shows a cross section of the transom and coil, shown in Fig. 504. One side of the box or transom enclosing the coil should be put up with round-headed screws so as to be removable at will.

There are at least two different makes of horizontal coiling partitions, those made by J. Godfrey Wilson having been the most extensively used. The Wilson partition works very satisfactorily for open-

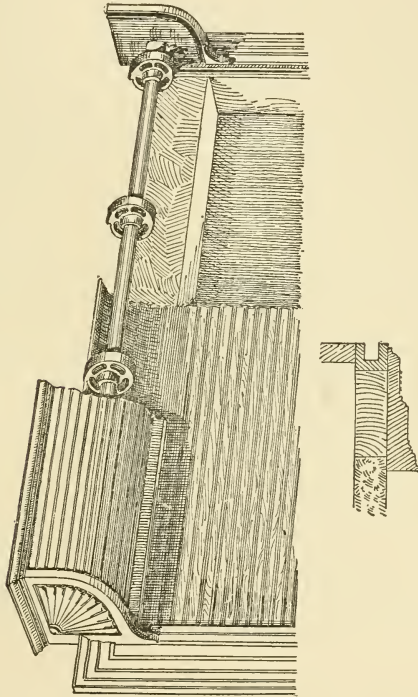

Fig. 502.—Wilson's Rolling Partition.

ings within the limits previously given. It is composed of wood slats  $1\frac{1}{2}$  to 2 inches wide and  $\frac{1}{2}$  to  $\frac{3}{4}$ -inch thick, fitted together with rule joints edge to edge, and threaded upon tempered steel bands running from top to bottom about 16 inches apart. These bands are riveted to the top bar of the partition, and each band is attached separately to a spiral spring anchor concealed in the bottom rail and

fitted with simple means of adjustment for regulating the tension. This tension on the steel bands holds all the slats in close contact and also permits of the extension of the steel bands as the partition

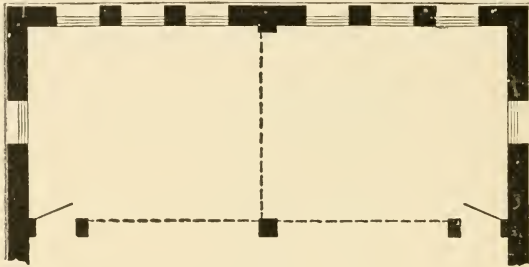

Fig. 503.

is coiled on the shaft. The partition is hung upon powerful spring rollers which exactly counter-balance the weight, so that the partition may be coiled with comparative ease and will stay wherever put.

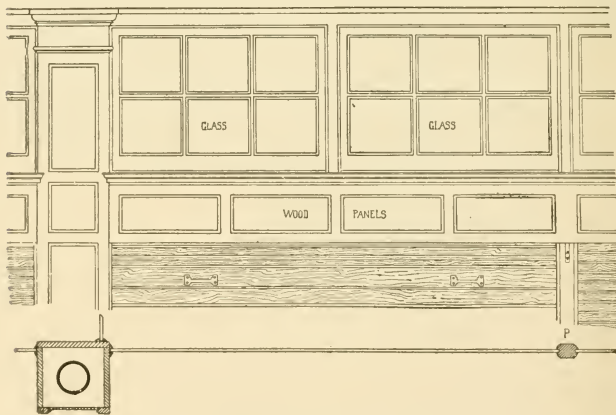

Fig. 504.—Casing for Wilson's Rolling Partitions.

One side of the partition may be prepared with a flat smooth surface for blackboard use or decorative purposes if desired.

For the Wilson partitions  $\frac{1}{2}$ -inch thick, the following spaces are required inside of the coil box ( $D, D$ ) to permit of coiling, the actual diameter of the coil being  $\frac{1}{2}$ -inch less:

Height of Opening.	Width $D$ for Partitions up to 10 feet wide.	Height of Opening.	Width $D$ for Partitions up to 10 feet wide.
6 feet.	10 inches.	14 feet to 15 feet.	15 inches.
7 feet.	11 "	16 feet.	16 "
8 feet to 9 feet.	12 "	18 feet.	18 "
9 feet, 10 feet to 11 feet.	13 "	19 feet to 20 feet.	19 "
12 feet to 13 feet.	14 "		

The Wilson partitions in whitewood,  $\frac{1}{2}$ -inch thick, varnished, are listed at 53 cents per square foot, and in quartered oak, varnished, at 65 cents for openings containing over 35 square feet and up to 20 feet high, all partitions being measured 1 foot above the sight opening, or to the top of box in which they coil. These prices include the necessary grooves, shaft rollers and iron handles.

Iron brackets like those shown in Fig. 502, are sold at \$3.00 per pair, and a special iron bracket is also made to go over movable posts.

**Vertical Coiling Partitions.**—These are constructed in the same general way as the horizontal partitions, but the shaft about which the partition coils is placed vertically in a box at the side of the opening.

Vertical partitions may be used for closing much wider openings than is practicable with the horizontal partitions, unless the opening is divided

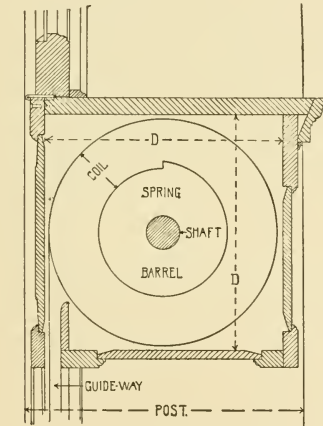

Fig. 505

by movable posts. Openings up to 50 feet wide may be closed with two of these doors, one at each side, without difficulty. These partitions, however, cannot be made as high as the horizontal partitions, 12 feet being the maximum height for the opening.

The first party to place a vertical coiling partition on the market was the Flexible Door and Shutter Co., who are still, the author believes, the leading manufacturers of this type of coiling partition.

The vertical flexifold partitions manufactured by this company, are constructed of solid wood mouldings connected by a series of concealed interlocking steel hinges which run through the entire width of the doors and are hung on steel rods in boxes ready for shipment.

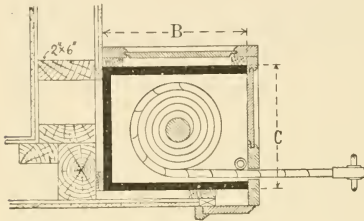

Fig 506.—Casing of Coil Box, Vertical Flexifold Partitions.

The rods revolve on a ball-bearing which reduces the friction to a minimum. The arrangement of the pocket is extremely simple, as the erection consists merely in setting the box plumb and casing it.

A clearance space of 10 inches over the box above the soffit of the opening is necessary for the coiling attachment, hence the header or supporting timber should be kept at least 10 inches above the top of the opening. Between the coil boxes, however, the soffit may be boxed down to receive the casing. When the opening

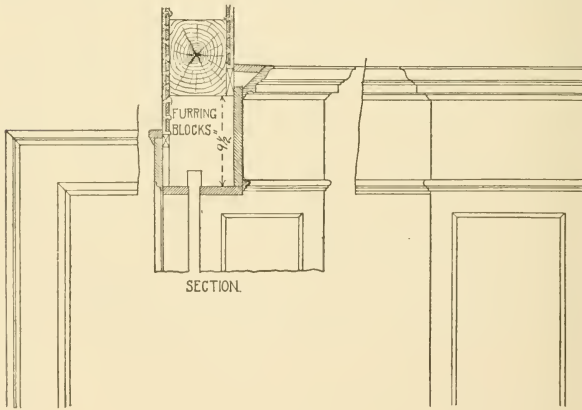

Fig. 507.

is in an 8-inch partition (6-inch studding), the cheapest method of arranging the coil box and casing the opening, is that shown in Fig. 506, which shows the size of a box for an opening 19 feet wide, closed by a pair of doors. The portion in solid black indicates the coil box.

Fig. 507 shows the casing on each side of the partition with a section through the head. Both sides of the box may be furred and plastered if desired.

Fig. 508 shows a style of casing adapted to openings 10 or 12 feet wide with the trim and doors finished in white enamel.

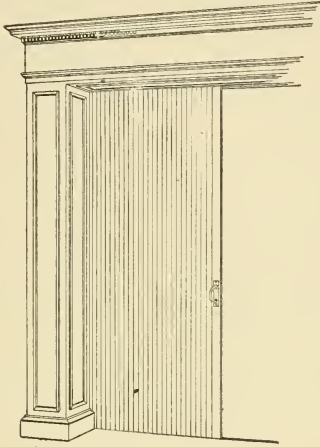

Fig. 508

To save room the coil box itself, may be paneled and finished at the factory.

Coils may be placed at one or both sides of the opening as desired, unless the opening is greater than 25 feet wide, when two coils are necessary. When the opening is closed by a single flexible door, it will often be a convenience to hang an ordinary door at the other side of the opening, as in Fig. 509, for use when the coiling partition is drawn out.

The dimensions of the box enclosing vertical flexifold partitions depends upon the width of the opening.

Following are the dimensions for *C* and *B*, Fig. 506, for various widths of doors, measured from the box jamb to the edge of the door when drawn fully out:

For width of	C.	B.
8 feet.	12 $\frac{1}{8}$ inches.	14 $\frac{3}{8}$ inches.
9 " 6 inches.	13 $\frac{5}{8}$ "	15 $\frac{1}{2}$ "
19 "	18 $\frac{3}{4}$ "	20 $\frac{1}{4}$ "

The bottom of these doors slides in a hard wood grooved track, set flush with the floor; this track is furnished with the doors.

The price of flexifold partitions depends on size of doors, kind of wood, finish, and if opening is to be closed with a single or a pair of doors.

For partitions in North Carolina pine, varnish finish, bronze trimmings, track, etc., all ready to set up, the price is about 70 cents per square foot for the openings between finished jambs. These partitions may be finished in white enamel if desired.

This company also manufactures small doors for closets, wardrobes, book cases, etc., and *flexifold steel clad* fire partitions, for fire wall openings and shut off which are approved and accepted by the

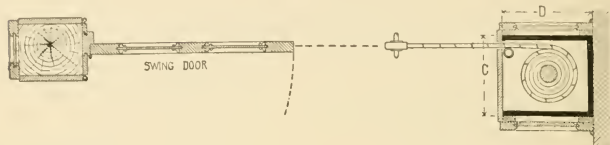

Fig 509.

Boston Board of Underwriters, and recommended in many places where the standard tin covered swing or sliding doors are impracticable, cumbersome, ungainly, or in the way.

#### REVOLVING DOORS.

The cold air constantly entering through the outside doors of large buildings during the winter months, has heretofore been a serious problem for the architect to solve. The entrance of snow, rain and dust during wind storms is almost equally as troublesome. To meet these objections as much as possible, vestibules have hitherto been provided with outer and inner doors, and where there is not space for the vestibule, "storm houses," forming a temporary vestibule are often put up in the fall and taken down in the spring. These precautions, however, have been found to only partially accomplish their purpose, and the great necessity of a device for public or semi-public entrances, that would more efficiently keep out the cold and dust, led to the invention of the "revolving door," which was first successfully introduced and operated in the year 1888.

The Franklin Institute of Philadelphia, after an exhaustive investigation and severe tests, awarded their highest medal to T. Van Kannel, the inventor and promotor of revolving doors. Letters patent were taken out by the inventor, and all of the important patents on revolving doors are now exclusively owned and controlled by the Van Kannel Revolving Door Company, of New York.

At the present time revolving doors are looked upon as next to indispensable for office buildings, hotels and other places where large numbers of persons pass in and out, and where it is desirable to keep out all wind, snow, rain and dust. They may be seen in operation in most of the principal cities of this country and Canada, and also in several European cities.

The standard revolving door consists of a circular vestibule 7 feet in diameter and  $7\frac{1}{2}$  feet high, inside. The front and back of this vestibule are open, as shown in the illustrations, but the top or ceiling, and the two circular walls form a complete enclosure. The revolving portion of the structure consists usually of four wings, which are joined at the centre and pivoted at the top and bottom. The upper pivot is suspended by a conical head, resting on a self-adjusting bearing in a four-wheeled truck, running in two strong channel irons placed on top of the ceiling. The wings are joined at the centre in such a way that they may be instantly folded flat on each other and moved aside in a few seconds of time.

The outer edges of each wing have a moulded rubber safety strip with 2 inches projection to prevent any pinching of hands and fingers, and rubber strips are also placed at the bottom, touching the floor, and at the top, making contact with the smooth ceiling, thus forming a perfect protection from wind and dust at all positions of the wings.

The operation of the door is indicated by the four diagrams, Fig. 510.

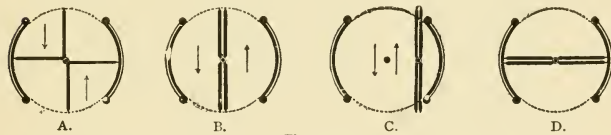

Fig. 510.

Diagram A represents the door in full operation, permitting persons to pass in and out, and at the same time excluding the wind, two of the wings being in contact with the walls in whatever position the revolving portion may assume. The wings may be folded flat on each other in the centre of the vestibule, as at B, and secured by means of bolts, thus affording two passageways. Should a full opening be desired, the wings may be instantly pushed aside and held in the position shown at C. Diagram D shows the wings folded across the entrance, in which position they may be securely locked.

It is claimed that the revolving door has a greater capacity than any other storm door in proportion to the space it occupies. All confusion and collision are avoided, and the passage of people in and out (at the same time) is uninterrupted.

The door cannot be left open, blown open or slammed.

The greatest advantage from a commercial point of view, is probably the saving in fuel which it effects.

The arrangement of the door in the entrance to a building may be varied considerably to suit the available space and the character of the building. Figs. 511-515 show various arrangements that have

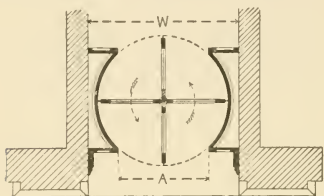

Fig. 511.



Fig. 512

been found very satisfactory, and several others are illustrated in the catalogue of the manufacturers. For the arrangement shown in Fig.

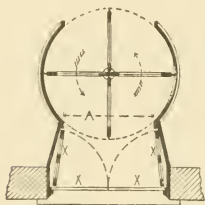

Fig. 513

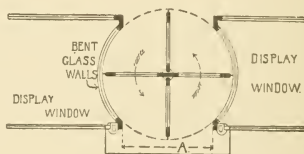

Fig. 514.

511, the minimum width between the corridor walls or partitions, to accommodate the standard (7-foot) door, is 7 feet 6 inches, but in

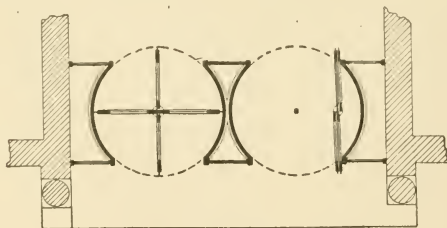

Fig. 515

case of necessity a smaller vestibule may be used requiring a width at  $W$  of only 6 feet 5 inches. With the 7-foot door, the width of the opening  $A$  is 5 feet, and in the 6-foot door, 4 feet.



When the width of the doorway is greater than that of the revolving door, the space may be filled by glazed or solid panels or mouldings.

In several instances the door has been placed outside of the building, simply reversing the plan, Fig. 512. For banks, etc., where it is desirable to retain the outside doors for greater security at night, the revolving door may be placed as in Fig. 513, and the permanent

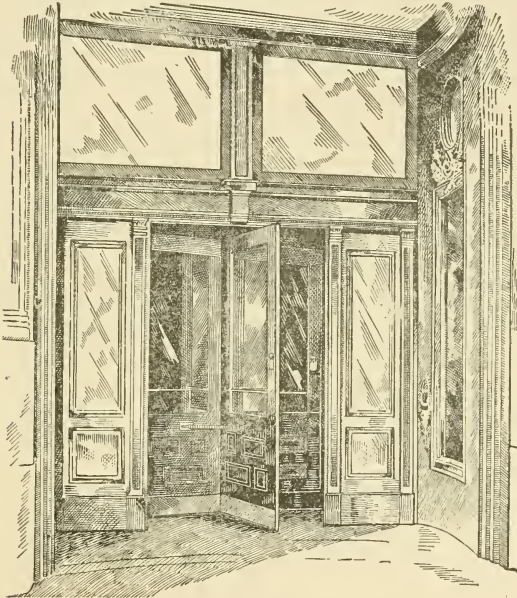

Fig. 516.—Van Kannel Revolving Doors.

doors *X, X*, held open against the door jambs, during the day, or while the revolving door is in use.

Fig. 514 shows a very desirable arrangement for retail stores, in which the circular walls of the revolving door also form the end walls of the display windows, taking up but little space and producing a handsome effect.

Fig. 515 shows a double set of doors as placed in the entrance of a large office building.

Fig. 516 shows the appearance of the door and vestibule from the outside when arranged as in Fig. 511. Transom lights are usually placed above the top of the vestibule or door.

Special revolving air lock doors are made to be placed between the kitchen and dining room of hotels and restaurants. Also for hospitals, factories, libraries and all places where it is desirable to keep out fumes, odors, dust or noise.

In many buildings a specially constructed revolving door may be used to cut off one room from another to prevent the passage of flames in case of fire, and also to prevent a draught; in fact there are many places besides those mentioned, where the revolving door can be used to great advantage.

#### DUMB WAITERS.

In buildings having the kitchen below the dining room, a dumb waiter is a necessity for serving the meals, and even where a dumb waiter is not needed from kitchen to dining room, it is a great convenience to have one running from cellar to kitchen or from laundry to upper floors.

A dumb waiter consists of a car enclosed in a shaft and suspended by ropes from a pulley, or pulleys above, so that it may be raised or lowered at will by means of a hand rope. The car itself is counter-balanced by iron weights, the extra weight due to the load being counter-balanced either by friction or resisted by a lock or grip. The car is steadied in its movement up and down by means of guide posts. The wheels and pulleys over which the ropes pass are made for this especial purpose, and are sold in sets under the name of Dumb Waiter Fittings. The car and guides may be made by the carpenter, who also usually furnishes the ropes and weights.

The size and shape of the car may be varied to suit the space available and the service required. The more common size for residences is 24 inches wide, 20 inches deep and 30 inches high, with two fixed shelves.

For tenement and apartment houses the car may be made 30 inches wide and 3 feet high, with one hinged shelf, so that a barrel may be set in it if desired.

The shaft should be at least 3 inches larger both ways than the car, and should be ceiled or plastered on the inside. With the style of machine shown in Fig. 520, a flat weight should be used to prevent the untwisting of the rope. If the weight runs between double guides, as shown, no extra space is required in the shaft, and the weight is readily accessible.

For the style of dumb waiter shown in Fig. 518, a square weight is used, running in a pocket behind or at one side of the shaft.

Dumb waiter fittings are a regular article of manufacture, and may either be bought separately or the complete apparatus, including car, ropes, runs, counter-weight, etc., all ready to erect, may be purchased, the latter being usually the more satisfactory method.

The character and detail of the fittings vary with the manufacturer and with the size and capacity of the car and speed desired.

Figs. 517 and 518 illustrate a style of dumb waiter that is very generally used in good work.

Fixed shelves are placed at the top and bottom of the shaft for receiving the wheels, and the ropes pass through these shelves.

Fig. 518 shows the position of the wheels on the top shelf.

The rope by which the car is operated is fastened to the fixed upper shelf *X*, at 1, and is carried down to and under the wheels *E E* on top of the car, up through the shelf and over the wheel *A*, thence to the wheels at the bottom of the shaft and up to and over the wheels *B* and *C*, and there connected with the counter-balance by a pulley, the end of the rope being fastened to the top shelf close by where it started. A safety rope is attached to the top of the car, carried up through the fixed shelf over pulley *D* and connected

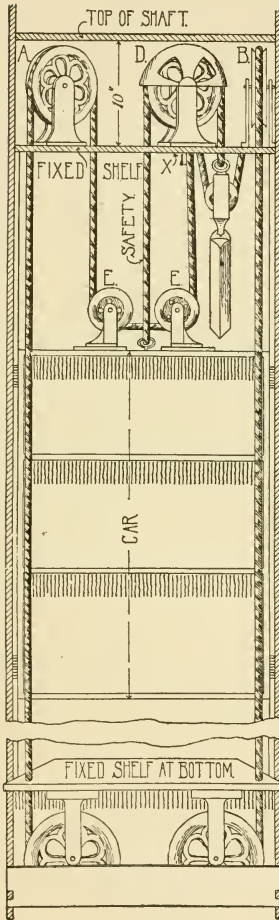

Fig. 517.—New York Safety Dumb Waiter.

with the counter balance so that should the operating rope break through long wear, the safety rope will keep the car from falling.

A brake grip, Fig. 519, is attached to the under side of the shelf, so that the hand rope which elevates the car will pass through it. A cord attached to the grip passes over a small hooded pulley and down along side of the hand rope. To hold the car when loaded beyond its balance, it is only necessary to pull on the small cord, and by

pulling on the hand rope the grip is released.

It will be seen that all the working connections of this elevator are made with a single rope, so arranged that no matter how much it may stretch it will always be taut, the slack being taken up by the counter-balance, so that the slightest motion of the rope will start the car

Fig. 520 shows the working mechanism of another type of dumb waiter, also very extensively used.

In this style the hand rope merely turns the large wheel by friction, and hangs loose at the bottom. Attached to the axle of the large wheel is a smaller wheel, over which a rope passes, fastened at one end to the car and at the other to the counter-weight. When the hand rope is pulled at one side or the other, the wheels are revolved and the car is raised or lowered according to the direction in which the wheels revolve.

The lifting capacity of the waiter is regulated by the size of the hand wheel, which varies from 16 to 30 inches in diameter.

The car is held automatically at any point by an automatic lock in the front bearing of the main shaft so that the car is always "locked" except when the rope is pulled.

The car shown in the illustration has one hinged shelf. There are several patterns of dumb waiters having a large wheel

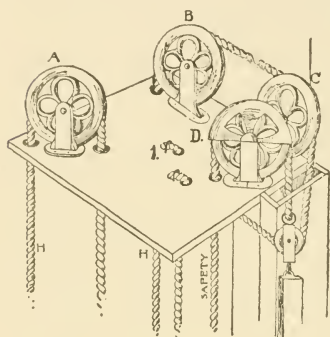

Fig. 518.—New York Safety Dumb Waiter.

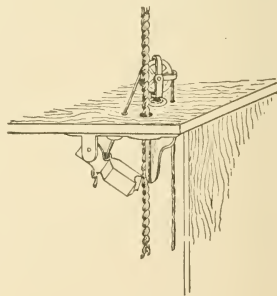

Fig. 519.—Brake Grip.

at the top for the hand rope and turning the pulley wheel either by a fixed shaft or by gearing, and nearly all of the larger dumb waiters are of this type. Owing to the size of the hand wheel, this type requires more space above the top of the car than the type shown in Fig. 517.

Dumb waiters or light elevators intended for buildings of several stories, are usually provided with a brake for the hand wheel, to which a check rope is attached, by means of which the speed of the car in descending may be regulated, the counterweight being adjusted so that the car will descend when the brake is released.

The fixtures for dumb waiters, not including ropes, weights or guide runs, nor the fixed platforms, cost about \$15 for the smallest size, and about \$25 for a medium size. With car and fittings all complete, the price varies from \$30 to \$40 for the smallest size, and up to \$60 for larger sizes. For a run of more than 10 feet an additional price of from \$5 to \$10 per story is charged for the ropes, runs, etc.

Most dumb waiters may be made "double face," that is with openings on opposite sides for different stories; this involves, however, an additional charge of about \$5 or \$6, and more in some cases. A few styles can also be adapted to openings on adjacent sides, but this arrangement is not

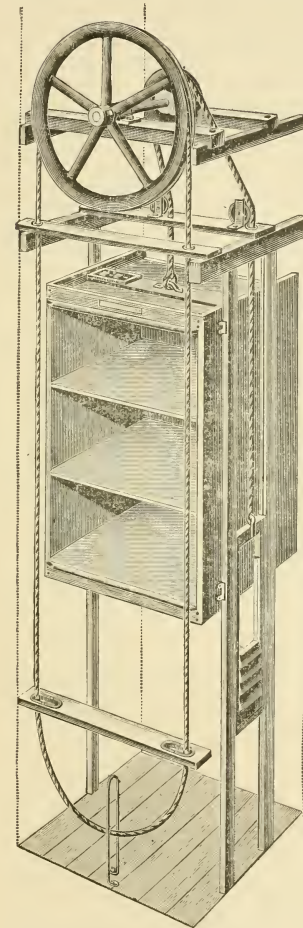

Fig. 520.—Sedgwick Automatic Dumb Waiter.  
(Sedgwick Machine Works)

desirable if it can be avoided. The doors at the openings into the

dumb waiter shaft are usually hung with cords and weights in the same manner as an ordinary window, and are provided with some form of spring catch which will hold the door either up or down.

### THE CUTLER PATENT MAILING SYSTEM.

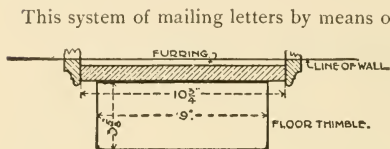

Fig. 521.

This system of mailing letters by means of a specially constructed chute connected with the receiving box at the bottom, has come into such general use in public buildings, office buildings, apartment houses and hotels, that

the restrictions affecting the same and what is required in the way of preparation, should be known to architects.

The system is installed by the patentees, under regulations of the Post Office Department governing its construction and location, and for this reason it is well to consult the makers, the Cutler Manufacturing Company, Rochester, N. Y., before permanently locating the apparatus on the plans.

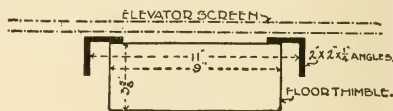

Fig. 522.

It may be placed in any building of more than one story used by the public, where there is free delivery and collection service, in the discretion of the local postmaster, subject to whose approval the contracts are made.

The chute is required to be in removable sections and a continuous, rigid, vertical support is absolutely necessary. It must be of metal, the front of plate glass, and bear the insignia prescribed by the department; and the whole apparatus when erected

and the Government lock put on the box, passes under the exclusive care and control of the Post Office Department, and the chutes become a part of the receiving boxes. These boxes may be of various patterns and highly ornamented; they are furnished by the makers

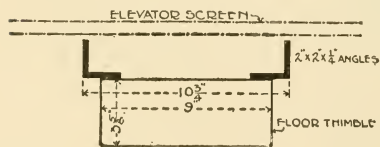

Fig. 523.

in connection with the chutes. The work of preparing a support for the chute and cutting and finishing the openings in the floors may be included in the general building contracts, and details showing the usual arrangements are therefore given.

The requirements for what the manufacturers call "preparatory work" are a flat, vertical, continuous surface not less than  $10\frac{1}{2}$  inches

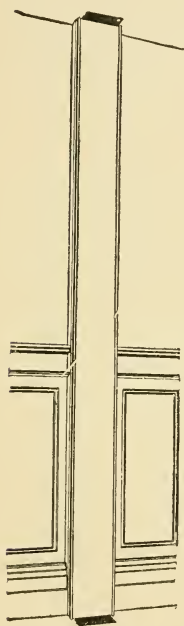

Fig. 524.—Preparatory Work Complete.

wide, extending from the floor in the ground story to a point 4 feet 6 inches above the finished floor in the top story, and an opening in each floor directly in front of and centred upon this surface. These openings are neatly and easily finished, and their size and shape determined by setting in them thimbles of iron which are furnished and delivered by the patentees, as part of their contract.

In ordinary cases a casing of wood, suitably moulded and finished to match the trim of the building, answers every purpose. Such a casing is shown in plan, Fig. 521, with the opening finished by the iron thimble.

In buildings (or sometimes in but a few stories) where a more elaborate finish is desired, marble is substituted for wood, the form and construction of the casing being adapted to the material, but of course without disturbing the size and form of the front surface.

Iron angles are used where the use of wood is objected to, or where it is necessary to run the chute in front of an elevator screen or in other locations where a solid wall is not available to support the casing. Two  $2 \times 2\frac{1}{4}$ -inch square root angles are generally used, turned so as to form a flat channel, as in Fig. 522, but sometimes—where it is desirable to fill up the space between them and the elevator screen—reversed, as in Fig. 523. The angles are usually bolted to the beams, and in any case must be straightened so that they are without twists or kinks, and the surface which receives the mail chute is perfectly plumb and flush in all stories.

This work of preparing the building is now often included in the mail chute contract, as it has been found for many reasons undesir-

able to separate it. Care should be taken, therefore, in specifying, to state whether the work of preparation is to be included with the figure for the mail chute or whether it has been otherwise provided for.

Fig. 524 gives a general view of the mail chute casing and floor openings ready to receive the mail chute.

Essential points to be remembered are: First, that no bends or offsets can be made—a vertical fall is absolutely essential; and second, the entire apparatus must be exposed to view and accessible—that is, it is not permitted to extend behind an elevator screen or partition or through any part of the building except a public corridor.

#### LUXFER PRISMS.

Luxfer Prisms are a commercial product made of glass of a standard dimension of 4 inches square, having a smooth outer surface and an inner surface divided into a series of prisms. They are formed into plates by the process of electro-glazing, the edges of the prism lenses being welded together, so to speak, by a narrow line of copper which gives the desired stiffness and strength for use in large frames and also an attractive appearance far superior to the ordinary leaded work. These prism plates can be made in any desired size, but for very large surfaces two or more plates, divided by means of iron sash bars, are generally used.

The commercial value of these prisms depends on the quality of glass known as refraction. Prism plates receive the light from the sky (not necessarily from the sun) and refract or turn it back into the room to be lighted. With ordinary windows the light from the sky, passing through the glass, strikes the floor at a point not very far distant from the window. As the floor is usually of a dark color, reflecting perhaps only one-tenth part of the light falling thereon, it will be seen that the rear of room receives only a small portion of the light entering the window. For this reason it has been necessary to make very high stories for deep rooms, in order to even moderately light portions at a distance from the window. When prisms are substituted for the common window or plate glass, the rays of light as they enter the glass are changed in direction, or refracted, and by employing a prism of the proper angle, may be given almost any desired direction. Moreover, by utilizing different prisms in the same plate, part of the rays may be directed to the rear of the room while others are thrown so as to strike near the front. The prism plates do not increase the quantity of light entering the window, but simply re-distribute it.



directing it into that portion of the room where it is most needed. By thus changing the direction of light rays a better lighted room can be secured, with less height of story, than when sheet or plate glass is used.

To insure success in the lighting of interiors by means of prisms requires, however, a superior quality of glass, careful scientific calculations and experiments, besides a practical and attractive means of glazing and method of installation. The author believes that these qualifications have been attained by the American Luxfer Prism Company, whose product may be considered as a new building material, and one which has been very successfully applied to the lighting of dark rooms by daylight.

The application of Luxfer Prisms to any particular building depends upon the surrounding conditions and requirements, each case requiring some special treatment, but in a general way the various methods of installation may be divided into classes as follows:

*Vertical plates*, which are set directly in the sash in place of the ordinary window glass. These are commonly used for the transom lights of store windows and for the upper sash of double-hung windows, or may fill the entire window.

*Foriluxes*, which are vertical prism plates set in an independent frame and placed in the window opening substantially flush with the face of the wall.

*Canopies*, which are external prism plates in independent frames placed over a window opening and set at an angle to the vertical, a position similar to that of an ordinary awning.

*Pavement prisms*, which are set in iron frames in the pavement or sidewalk, in place of the ordinary bull's-eye light. In connection with the pavement prisms, when a well-lighted basement is desired, there is used a vertical plate of prisms, called the *Lucidux*, which is hung below and opposite the pavement light. This *Lucidux* receives the light from the pavement prisms, and again changing its direction, projects it horizontally into the basement. (This feature is illustrated by Fig. 525.)

The canopies may be made either stationary or adjustable and may be employed in a variety of ways, combining the useful with the ornamental. The *Foriluxes* are susceptible of many highly decorative effects. In both the vertical plates and *Foriluxes*, the prisms may be arranged to produce ornamental effects, and by the use of the "Iridian" product a design may be inwrought upon the face of the prism plate to correspond with the design worked into the sur-

faces of the building and with the style of the entire front. The prism plates weigh no more and often less than plate glass of the same size, while they are much stronger to resist wind pressure, the action of hail and the impact of flying fragments. Although approaching perfection in the transmission of light, the prism plates are not transparent in the ordinary sense, and thus may be used as a screen to hide an unattractive view, or to prevent persons looking either in or out of the window, while at the same time the maximum quantity of light is admitted. The prism plates, owing to the stiff, durable manner in which they are united by the electro-glazing process, are also used for fire protection as a substitute for the ordinary

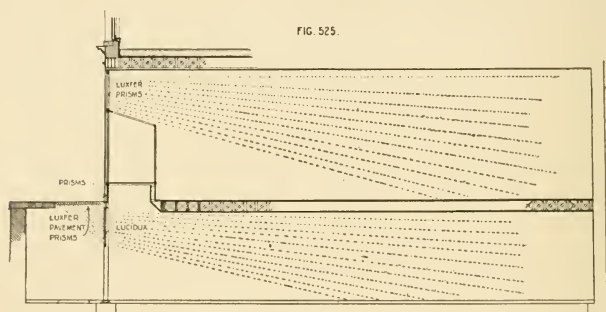

iron fire shutter. The copper glazing forms, as it were, a continuous rivet, which holds the individual prism lights together even after they have become badly cracked by the action of fire and water.

The details of Luxfer Prisms are too complicated to be set forth in a few pages, but they are well described in a handbook published by the company. From a commercial point of view the special advantages of this system of interior lighting are manifold. It transforms rooms, particularly basements, otherwise too dark for occupancy, into income-producing space; in many buildings avoids the use of light shafts, thus saving a large amount of valuable floor space; and in all large or deep rooms effects a great saving in artificial lighting. Once installed, there is no cost for maintenance. The extent to which these prisms have been used by architects, on both new and old buildings, shows that they are to have a decided influence upon commercial architecture.

COMPARATIVE STRENGTH AND DURABILITY OF  
SASH CORD AND CHAINS.\*

The following summary of the result of a test to determine the relative durability against wearing of a No. 8 Samson, white "spot" sash cord, and of the Monarch sash chain, No. 2, made in 1900 at the Massachusetts Institute of Technology by Prof. Edward F. Miller, is of value in determining what to use for hanging heavy sash. The cords and chains were passed over special  $2\frac{1}{2}$  inch pulleys, and had a 25 lb. weight attached to one end. The other end was operated up and down by means of a crank pin driven at a speed of about twenty turns a minute, each turn representing an opening and closing of a window. Seven pieces of cord and fifteen of the chain were tested.

SUMMARY OF TESTS.

	AVERAGE TENSILE STRENGTH IN LBS.	AVERAGE NUMBER OF LIFTS AT TIME OF FAILURE.	MINIMUM NUMBER OF LIFTS AT TIME OF FAILURE.	COST PER FOOT.	COST PER ONE HUNDRED WINDOWS.
Cord,	338	214,371	96,988	$\frac{3}{4}$ cts.	\$18.00
Chain,	662	75,848	20,735	5 "	120.00

These tests show that there is no relationship between the tensile strength and the durability in running over pulleys.

How much a cotton cord will deteriorate with age is not definitely known. The common cords sometimes play out in a few years, and on the other hand, there have been instances where first quality cord has been in continued use for thirty years.

Unless the pulley is adapted to the cord, however, the life of the cord will be very much shortened. When sash cord is used with heavy weights very often the cord is either too small, or the pulley is too small to carry the cord, sometimes even cutting the cord on the edges of the pulley.

To obtain the best result a smooth, even running pulley, having both the groove and the diameter large, should be selected. The larger the diameter of the pulley, the longer the wear.

The diameter and face of pulley should also be carefully considered when using chains.

\*Addenda to Fourth Edition.

even when people are passing through, there is no opportunity for fire or smoke to enter the stairway.

Interior fire doors can be handsomely made so as to in no wise detract from the architectural effect of the interior of the building.

#### THE MASON SAFETY TREAD.

This is an ingenious patented combination of steel, iron, brass or other hard metal, with lead firmly rolled into dovetail grooves, for protective use on stairs, landings and inclined floorings, or wherever accidents from slipping are possible.

The tread is made in plates,  $\frac{1}{4}$  inch thick, and in different widths, and is intended to be either placed upon the surface of treads and landings, or sunk in a recess, as may be preferred. Fig. 535 represents a full size section of a strip,  $3\frac{1}{2}$  inches wide, with nosing on one edge, and Fig. 536 of a 2 inch strip without nosing. Fig. 537 shows the application of the tread to stairs.

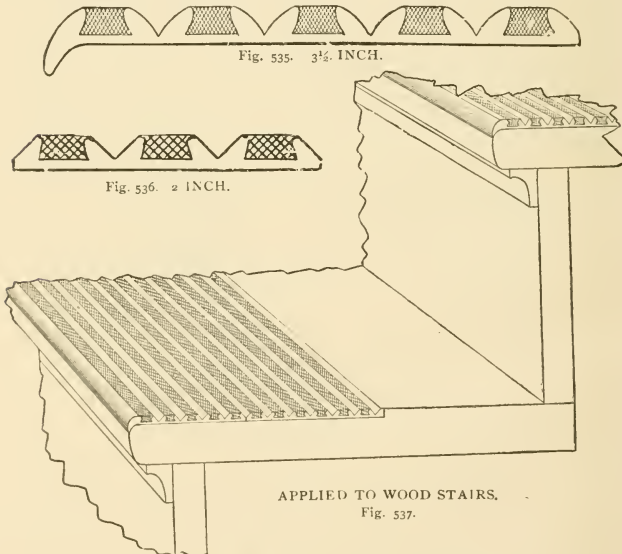

The combination of a hard metal to resist wear, and a soft substance to prevent slipping, gives, we believe, the most perfect surface

for the purpose that has as yet been devised, and the great extent to which it has been used, during the few years that have elapsed since it was placed on the market, has fully demonstrated its merits. These treads also render the impact of the foot noiseless, which is often a very desirable consideration.

For general use, the tread is made of steel and lead, the etched portions on Figs. 535 and 536 being lead. For use in places where an especially nice appearance is desired, a hard brass composition may be substituted for steel, and for use on exterior stone work, or marine work, the steel may be galvanized.

The safety tread is made in 2 inch,  $3\frac{1}{2}$  inch, 4 inch and 6 inch widths, the  $3\frac{1}{2}$  inch width being the only one having a nosing. The  $3\frac{1}{2}$  inch width may be used in conjunction with the other widths, to cover a strip to the depth of  $5\frac{1}{2}$ ,  $7\frac{1}{2}$ , or  $9\frac{1}{2}$  inches. The other widths are used without the nosing, making 4, 6, 8, 10 or more inches in multiples of two. The joints, being at the bottom of the groove, are invisible, so that the appearance is that of a continuous plate.

When an odd width is required it should be so arranged as to have the material cut through one of the V grooves, and not through the lead. For treads of usual width the 6 inch strip answers every purpose; for extra wide treads,  $7\frac{1}{2}$  or 8 inches should be used. The use of the nosing is optional and on ordinary stairs is more for appearance than for any practical advantage. On wood stairs the safety tread is more frequently placed upon the surface, the ends of the strips being beveled. It is attached with screws, all necessary holes being punched and counter sunk at the factory, so that the tread is ready to be put in place immediately on delivery. The length of the tread is generally made 6 inches less than the width of the stairs, thus allowing a space of 3 inches at each end.

The safety tread may be curved when desired to any given radius.

Non-slippery coal-hole covers, sidewalk lights, etc., are made on the same principle as the Mason Stair Treads, by the same company.

*Specifications:* The following is a concise and frequently used form of specifications for these treads:—All steps and platforms are to be provided with (and rebated for) Mason Safety Treads,—inches wide and in length to run within 3 inches of skirting or balusters; to the platforms, also, provide and set in rebate, at 6 inches distance from the first riser, the Mason Safety Treads, 8 inches wide.

“Provide and set Mason Non-slipping Illuminated Coal-Hole Covers, as shown on plans.”



# APPENDIX B.

## TABLES OF THE STRENGTH OF MATERIALS.

The following tables and formulæ are given for the benefit of those readers who may not have at hand a special work treating of the subject. They are in all cases based upon the formulas and unit strains given in the author's *Architects' and Builders' Pocket Book* and a portion of the tables are copied direct:

TABLE I.  
PROPERTIES OF TIMBER, STONES, IRON AND STEEL.

	Weight per cubic foot in pounds. Average.	Weight per foot, <sup>2</sup> B. M. in pounds. Average.	Safe Tensile Strength, lbs. per square inch.	Safe Crushing Strength in pounds per square inch.	Safe Centre Load, lbs. for Beam 1 inch square and 1 foot long.*	Safe Shearing Strength with the Grain, pounds per square inch.	Safe Crushing Strength across the Grain, pounds per square inch.
Chestnut.....	40	3.3	1,500	530	60	....	....
Hemlock.....	30	2.5	1,200	450	55	70	200
Oak, white.....	52	4.3	2,000	750	75	150	600
Pine, Georgia yellow.	43	3.6	2,000	1,000	100	120	500
Pine, Oregon.....	36	3	1,800	800	90	100	400
Pine, Norway.....	36	3	1,600	700	70	90	400
Pine, white Western .	30	2.5	1,500	625	65	80	200
Redwood.....	30	2.5	800	600	60	70	175
Spruce.....	36	3	1,800	700	70	90	250
Whitewood.....	35	3	1,200	500	65	....	200
Slate.....	174	..	....	....	40	....	....
Bluestone flagging...	..	..	....	....	25	....	....
Granite.....	167	..	....	850	18	....	....
Limestone (Ind.)....	158	..	....	550	18	....	....
Marble.....	170	..	....	550	18	....	....
Sandstone.....	139	..	....	450	12	....	....
Cast iron.....	450	..	2,600	13,500	222	7,000	....
Wrought iron.....	480	..	10,000	10,000	666	7,500	12,000
Steel, medium.....	490	..	12,500	13,000	888	7,500	12,000
"    pins.....	..	..	....	....	..	7,500	12,000
"    rivets....	..	..	....	....	..	7,500	15,000

\* One-eighteenth of the "fibre strain or safe " Modulus of Rupture."

† For full permanent loads, such as brick walls, etc., use only four-fifths of these values.

TABLE II.

## STRENGTH OF ROUND RODS OF IRON AND STEEL.

Diameter in inches.	NOT UPSET. Allowed strain per sq. in.*			UPSET. Allowed strain per sq. in.*		
	10,000 lbs.	12,500 lbs.	15,000 lbs.	10,000 lbs.	12,500 lbs.	15,000 lbs.
1	1,256	1,570	1,884	1,963	2,453	2,944
1	1,963	2,453	2,944	3,068	3,835	4,600
1	3,000	3,750	4,500	4,418	5,520	6,627
1	4,200	5,250	6,300	6,013	7,516	9,020
1	5,430	6,780	8,140	7,854	9,815	11,780
1	6,860	8,570	10,290	9,940	12,425	14,900
1	8,850	11,060	13,270	12,270	15,330	18,400
1	10,700	13,370	16,050	14,840	18,550	22,260
1	12,870	16,080	19,300	17,670	22,080	26,500
1	15,000	18,750	22,500	20,730	25,910	31,090
1	17,600	23,000	26,400	24,050	30,060	36,070
1	20,200	25,250	30,300	27,610	34,500	41,400
2	22,800	28,500	34,200	31,420	39,270	47,130
2	26,400	33,000	39,600	35,460	44,320	53,190
2	30,000	37,500	45,000	39,760	49,700	59,680
2	33,500	41,870	50,250	44,300	55,370	66,450
2	37,200	46,500	55,800	49,080	61,350	73,620
2	46,400	58,000	69,800	59,390	74,230	89,080
3	54,000	67,500	81,000	70,680	88,350	106,000
3	65,000	81,250	97,500	82,950	103,690	124,400
3	75,400	94,250	113,100	96,210	120,260	144,300
3	85,600	107,000	128,400	110,450	138,060	165,600
4	99,000	123,750	148,500	125,660	157,000	188,490
4	113,400	141,700	170,100	141,800	177,250	212,700
4	126,000	157,500	189,000	159,000	198,750	238,500
4	141,800	177,250	212,700	177,200	221,500	265,800
5	157,600	197,000	236,400	196,300	245,370	298,400
5	175,900	219,870	263,850	216,400	270,500	324,000
5	192,600	240,750	288,900	237,500	296,800	356,000
5	212,300	265,370	318,400	250,600	324,500	389,000
6	231,000	288,750	346,500	270,700	353,300	424,000

\* For first-class work and material 12,500 lbs. may be allowed for iron and 15,000 lbs for steel. If the rods are to be welded or are made by an ordinary blacksmith, use 10,000 lbs for iron and 12,500 lbs. for steel.

## STRENGTH OF WOODEN POSTS.

For wooden posts in buildings used for ordinary purposes, when the length in inches does not exceed twelve times the least thickness, the safe strength of the post may be obtained by multiplying its sectional area in square inches by 1,000 for long leaf yellow (hard) pine, 900 for Oregon pine, 800 for spruce or white oak, and 700 for white pine. For machinery or full permanent loads (as a brick or stone wall) these values should be *reduced one-fifth*.

The safe load for posts whose length *in inches* exceeds twelve times their least dimension may be computed by means of the follow-



ing table, allowing four-fifths for Oregon pine, three-fourths for oak and Norway pine, and five-eighths for spruce and white pine of good quality:

TABLE III.  
SAFE LOAD IN POUNDS FOR YELLOW PINE POSTS (ROUND AND SQUARE).

SIZE OF POST IN INCHES.	LENGTH OF POST IN FEET.									
	8	10	12	14	15	16	18	20	24	
4x6	18,300	16,800	15,360	.....	.....	.....	.....	.....	.....	
5½ Round.	19,590	18,760	17,550	16,400	.....	.....	.....	.....	.....	
6x6	30,300	28,800	27,400	25,900	25,200	24,500	.....	.....	.....	
6x8	40,300	38,400	36,500	34,600	33,600	32,600	.....	.....	.....	
6x10	50,400	48,000	45,600	43,200	42,000	40,800	.....	.....	.....	
7½ Round.	38,540	37,130	35,71	34.30	33,590	32,890	.....	.....	.....	
8x8	64,000	54,400	52,500	50,600	49,600	48,600	46,700	.....	.....	
8x10	80,000	68,000	65,600	63,200	62,000	60,800	58,400	.....	.....	
8x12	96,000	81,600	78,700	76,800	74,400	73,000	70,100	.....	.....	
9½ Round.	70,900	61,970	60,190	58,350	57,420	56,580	54,800	.....	.....	
10x10	100,000	100,000	83,600	83,200	82,000	80,800	78,400	76,000	.....	
10x12	120,000	120,000	102,700	99,800	98,400	97,000	94,100	91,200	.....	
10x14	140,000	140,000	119,800	116,500	114,800	113,000	109,800	106,400	.....	
11½ Round.	103,900	101,900	99,912	88,730	87,690	86,650	84,160	82,290	.....	
12x12	144,000	144,000	144,000	123,800	122,400	121,000	118,100	115,200	109,400	
12x14	168,000	168,000	168,000	144,500	142,800	141,100	137,800	134,400	127,680	
12x16	192,000	192,000	192,000	165,160	163,200	161,200	157,400	153,600	145,920	
14x14	196,000	196,000	196,000	196,000	170,500	169,100	165,800	162,400	155,800	
16x16	256,000	256,000	256,000	256,000	229,100	228,300	224,400	217,600	209,900	
18x18	324,000	324,000	324,000	324,000	324,000	289,400	285,100	280,800	272,160	
2 x 20	400,000	400,000	400,000	400,000	400,000	400,000	356,800	352,000	342,400	

CRUSHING STRENGTH OF TIMBER PERPENDICULAR TO THE GRAIN.

The bearing of wooden girders at their ends, or over a post, or of a post resting on a girder should be sufficient that the load will not crush the fibres of the beam. The following loads *per square inch of bearing surface*, may be allowed for the various woods given:

White oak.....	600 lbs.	Colorado pine.....	200
Yellow pine.....	500 "	Spruce.....	250
Oregon pine.....	400 "	Hemlock.....	200
Norway pine.....	250 "	Cypress.....	200
White pine.....	200 "	Redwood.....	175

CAST IRON COLUMNS.

Short posts of cast iron, with a length *in inches* not exceeding eight times their least dimension, may be safely loaded with six tons for each square inch of metal in the cross section.

The safe load for longer columns should be computed by means of accepted formulas. These formulas vary for different forms of cross section; they may be found in most books of references. The following table gives the safe loads for hollow cylindrical columns with ¾-inch shell, and caps and bases cast as described in Section

260. Tables for other thicknesses of shell and for square and rectangular columns are given in the *Architects' and Builders' Pocket Book*.

TABLE IV.

SAFE LOADS IN TONS FOR HOLLOW CYLINDRICAL CAST IRON COLUMNS.

THICKNESS OF SHELL $\frac{3}{4}$ INCH.								
Length of column.	Diameter of column (outside).							
	6 ins.	7 ins.	8 ins.	9 ins.	10 ins.	11 ins.	12 ins.	13 ins.
Feet.	Tons.	Tons.	Tons.	Tons.	Tons.	Tons.	Tons.	Tons.
6	60.6	78.1	94.0	110.8	128.6	144.9	161.7	180.0
7	55.7	72.2	88.9	106.9	124.2	140.1	156.4	176.0
8	50.7	66.3	83.8	101.1	117.7	135.2	151.1	170.3
9	45.8	61.9	78.7	95.2	113.4	130.4	145.8	164.5
10	40.8	56.0	73.5	89.4	106.8	123.2	140.5	158.7
11	37.1	51.5	68.4	83.6	100.1	118.3	135.2	153.0
12	33.4	47.1	63.3	79.7	95.9	113.5	129.9	147.2
13	30.9	44.2	58.1	73.9	89.4	106.3	124.6	141.4
14	27.2	39.8	54.7	70.0	85.0	101.4	119.2	135.6
15	24.7	36.8	49.6	64.1	78.5	96.6	114.0	129.9
16	22.3	33.9	46.2	60.3	71.9	91.8	108.7	124.1
18	....	29.0	41.0	52.5	67.6	84.5	103.4	118.3
20	....	24.4	36.0	44.7	63.3	77.2	98.1	112.5
Metal area of cross-section.								
	sq. ins.	sq. ins.	sq. ins.	sq. ins.	sq. ins.	sq. ins.	sq. ins.	sq. ins.
	12.37	14.73	17.10	19.44	21.80	24.15	26.51	28.86



## STRENGTH OF WOODEN BEAMS.

The safe loads for rectangular wooden beams supported at both ends and *uniformly loaded* over the entire span, are computed by the formula:

$$\text{Safe load.} = \frac{2 \times \text{breadth} \times \text{square of depth} \times A}{\text{Span in feet.}}$$

the breadth and depth being taken in inches.

Values for A are given in the fifth column of Table I. When the load is applied at the centre but *one-half* of the load obtained by the above formula should be allowed.

For a canti-lever beam *fixed at one end* and uniformly loaded, take *one-fourth* of the value given by the formula, and if loaded at outer end take one-eighth.

Thus, if a beam of 12 feet clear span will support 1,000 pounds distributed load, it will support only 500 pounds at the centre, while the same beam fixed at one end and projecting 12 feet will support a distributed load of 250 pounds, or a load at the outer end of 125 pounds. To find the safe load for a cylindrical beam divide the load for a corresponding square beam by 1.7. For other methods of loading the reader is referred to the formulæ in the *Architects' and Builders' Pocket Book*.

TABLE VI.

## SAFE DISTRIBUTED LOADS FOR HARD PINE BEAMS.

One inch thick, supported at both ends.

For other thicknesses, multiply the load in table by the thickness of the beam in inches. For concentrated load at centre *divide by two*. For permanent loads such as masonry, reduce 10 per cent.

Span in feet.	Depth of Beam in Inches.									
	4	6	7	8	9	10	12	14	15	16
6	533	1,200	1,633	2,133	2,700	3,333	4,800	6,533	7,500	8,533
8	400	900	1,225	1,600	2,025	2,500	3,600	4,900	5,633	6,400
10	320	720	980	1,280	1,620	2,000	2,880	3,920	4,500	5,120
12	....	600	816	1,066	1,350	1,666	2,400	3,266	3,750	4,266
14	....	514	700	914	1,157	1,428	2,056	2,800	3,214	3,656
15	....	480	653	853	1,080	1,333	1,920	2,613	3,000	3,412
16	....	....	612	800	1,012	1,250	1,800	2,450	2,816	3,200
17	....	....	....	753	953	1,176	1,694	2,306	2,653	3,012
18	....	....	....	....	900	1,111	1,600	2,177	2,500	2,844
20	....	....	....	....	....	1,000	1,440	1,960	2,250	2,560
22	....	....	....	....	....	....	1,309	1,782	2,045	2,327
23	....	....	....	....	....	....	....	1,704	1,956	2,226
24	....	....	....	....	....	....	....	1,633	1,875	2,133
25	....	....	....	....	....	....	....	1,568	1,800	2,048
27	....	....	....	....	....	....	....	1,451	1,666	1,896

Loads below and to the left of heavy line may crack plastered ceilings.

Tables VI and VII give the safe distributed loads for long leaf yellow pine and spruce beams 1 inch thick, by which the strength of beams of any thickness may be easily obtained.

TABLE VII.

## SAFE DISTRIBUTED LOADS FOR SPRUCE BEAMS.

One inch thick, supported at both ends.

For other thicknesses, multiply the load in table by the thickness of the beam in inches. For concentrated load at centre *divide by two*. For permanent loads such as masonry, reduce 10 per cent.

Span in feet.	Depth of Beam in inches.									
	4	6	7	8	9	10	12	14	15	16
	lbs.	lbs.	lbs.	lbs.	lbs.	lbs.	lbs.	lbs.	lbs.	lbs.
6	373	840	1,143	1,493	1,890	2,333	3,360	4,573	5,250	5,973
8	280	630	857	1,120	1,417	1,750	2,520	3,430	3,937	4,480
10	224	504	686	896	1,134	1,400	2,016	2,744	3,150	3,584
12	....	420	572	746	945	1,166	1,680	2,286	2,625	2,986
14	....	360	490	640	810	1,000	1,440	1,960	1,875	2,540
15	....	....	457	597	756	933	1,344	1,828	2,100	2,388
16	....	....	....	560	708	875	1,260	1,715	1,968	2,240
17	....	....	....	....	667	824	1,186	1,614	1,853	2,108
18	....	....	....	....	....	777	1,120	1,524	1,750	1,991
20	....	....	....	....	....	700	1,018	1,372	1,575	1,792
22	....	....	....	....	....	....	....	1,247	1,431	1,629
23	....	....	....	....	....	....	....	1,184	1,360	1,558
24	....	....	....	....	....	....	....	1,143	1,312	1,493
25	....	....	....	....	....	....	....	1,097	1,260	1,433

Loads below and to the left of heavy line may crack plastered ceilings.

For *Oregon* or *Texas pine* beams take  $\frac{9}{10}$ -ths of loads in Table VI; for common white pine,  $\frac{6}{10}$ ; and for *hemlock*,  $\frac{6\frac{1}{2}}{10}$ . *Norway pine* has about the same strength as spruce.

#### TABLES FOR THE MAXIMUM SPAN FOR FLOOR JOISTS, CEILING BEAMS AND RAFTERS.

When the span of a wooden beam exceeds about twelve times its depth the beam will usually deflect so much under its full safe load as to crack plastering if applied on the under side, and as floor and ceiling beams are generally used for a greater span than twelve times their depth, they should be computed by the formulæ for *stiffness* rather than for strength.

In determining the size of floor beams the superimposed load and the span are the two elements which vary the most, the beams themselves being usually sawn to regular sizes while the spacing is generally either 12 or 16 inches. In tabulating the size of beams for different loads, the author has found that tables giving the maximum

safe span are the most convenient for general use, and with this view the following tables have been prepared, which show at a glance the maximum span for which different sizes of floor and ceiling joists should be used for different loads and spacings, and it is believed that they will be found applicable to most buildings in which wooden floor joists are used.

By knowing the size of the room to be covered and the purpose for which it is to be used, the size of joist required can be told at a glance. Incidentally the tables also show which kind of wood will be most economical.

If, owing to the room being irregular in shape, the joists must be of different lengths, the spacing or thickness of the joists may be varied, so that the same depth may be used throughout.

The only *precautions* to be exercised in using these tables are in regard to the superimposed load and the actual size of the timbers.

The total loads for which the maximum spans have been computed are given at the head of each table. The actual weight of the floor (beams, flooring, plastering and deafening, if any) subtracted from the total load will give the superimposed load, *i. e.*, the load which the floor is expected to carry.

The superimposed load to be assumed for any given building is to a large extent a matter of judgment, as circumstances may demand a higher limit for one building than for another, even of the same general class. In general the tables may be considered safe for the classes of buildings indicated.

TABLE VIII.  
MAXIMUM SPAN FOR CEILING JOISTS.  
Total load, 20 pounds per square foot.

Size of Joist.	Dist. on Centres.	Hemlock.		White Pine.		Spruce or Norway Pine.		Oregon or Texas Pine.		Georgia Pine.	
		Ft.	Ins.	Ft.	Ins.	Ft.	Ins.	Ft.	Ins.	Ft.	Ins.
2x4	12	9	3	9	5	10	1	10	5	11	2
2x4	16	8	5	8	6	9	1	9	5	10	1
2x6	12	14	0	14	1	15	1	15	7	16	8
2x6	16	12	8	12	10	13	8	14	2	15	2
2x8	12	18	8	18	10	20	1	20	9	22	4
2x8	16	17	0	17	2	18	4	18	11	20	5
2x8	20	15	9	15	10	17	0	17	6	18	10
Total load, 24 pounds per square foot.											
2x10	12	22	0	22	2	23	8	24	5	26	4
2x10	16	20	0	20	2	21	7	22	3	23	10
2x10	20	18	6	18	8	20	0	20	7	22	2
2x12	12	26	5	26	8	28	5	29	4	31	7
2x12	16	24	0	24	2	25	10	26	8	28	8
2x12	20	22	3	22	5	24	0	24	8	26	8

In some localities framing lumber is often *sawn a little scant* in both thickness and depth, and wherever such is the case a corresponding reduction must be made in the safe span. A reduction should also be made for any cutting of the joists that may be required.

No allowance has been made for partitions, and when they are to be supported by the floor joists additional joist should be used or the span reduced according to the relative direction or position of the partition and joists.

Tables VIII to XII, inclusive, were computed by the formula for stiffness, on the assumption that the deflection should not exceed  $\frac{1}{30}$  of an inch per foot of span. Tables XIII and XIV were computed by the formula for strength.

The spans given in these tables come within the requirements of the New York, Buffalo and Denver building laws, and tables VIII, X, XI, XII and XIV comply with the Chicago law, but to comply with the Boston law a reduction of about one-sixth must be made from the spans given.

By Georgia pine is meant the long-leaf, yellow or hard pine.

TABLE IX.

MAXIMUM SPAN FOR FLOOR JOISTS.

Dwellings, Tenements and Grammar School Rooms With Fixed Desks.

Total load, 60 pounds per square foot.

Size of Joists	Dist. on Centres.	Hemlock.		White Pine.		Spruce or Norway Pine.		Oregon or Texas Pine.		Georgia Pine.	
		Ft.	Ins.	Ft.	Ins.	Ft.	Ins.	Ft.	Ins.	Ft.	Ins.
2x6	12	9	9	9	10	10	5	10	10	11	7
2x6	16	8	9	8	10	9	6	9	10	10	6
3x6	12	11	1	11	2	12	0	12	5	13	4
3x6	16	10	1	10	2	10	10	11	2	12	1
2x8	12	12	11	13	1	13	11	14	5	15	6
2x8	16	11	9	11	10	12	8	13	1	14	1
3x8	12	14	9	14	11	16	0	16	6	17	8
3x8	16	13	6	13	7	14	6	15	0	16	2
2x10	12	16	2	16	4	17	5	18	0	19	4
2x10	16	14	9	14	10	15	9	16	4	17	7
Total load, 66 pounds per square foot.											
3x10	12	18	0	18	1	19	3	20	0	21	6
3x10	16	16	3	16	5	17	7	18	2	19	6
2x12	12	18	10	19	0	20	3	20	10	22	6
2x12	16	17	2	17	3	18	4	19	0	20	6
3x12	12	21	6	21	8	23	2	24	0	25	9
3x12	16	19	7	19	8	21	1	21	9	23	5
2x14	12	22	0	22	2	23	8	24	4	26	3
2x14	16	20	0	20	1	21	6	22	2	23	10
2½x14	12	23	8	23	10	25	6	26	3	28	3
2½x14	16	21	6	21	8	23	2	23	10	25	8
3x14	12	25	4	25	4	27	1	28	0	30	1
3x14	16	23	0	23	0	24	7	25	4	27	4

TABLE X.

MAXIMUM SPAN FOR FLOOR JOISTS.

## Office Buildings.

Total load, 93 pounds per square foot.

Size of Joists.	Dist. on Centres.	White Pine.		Spruce or Norway Pine.		Oregon or Texas Pine.		Georgia Pine.	
		Ft.	Ins.	Ft.	Ins.	Ft.	Ins.	Ft.	Ins.
3x8	12	12	10	13	9	14	2	15	4
3x8	16	11	8	12	6	12	10	13	10
2x10	12	14	1	15	1	15	6	16	7
2x10	16	12	9	13	8	14	1	15	2
3x10	12	16	1	17	3	17	9	19	2
3x10	16	14	8	15	8	16	2	17	5
2x12	12	16	10	18	1	18	8	20	1
2x12	16	15	4	16	5	17	0	18	3
Total load, 96 pounds per square foot.									
3x12	12	19	2	20	6	21	2	22	9
3x12	16	17	5	18	7	19	3	20	8
2x14	12	19	6	20	10	21	7	23	2
2x14	16	17	9	19	0	19	7	21	2
2½x14	12	21	1	22	6	23	2	25	0
2½x14	16	19	2	20	4	21	2	22	8
3x14	12	22	4	23	10	24	8	27	7
3x14	16	20	4	21	8	22	5	24	1

TABLE XI.

MAXIMUM SPAN FOR FLOOR JOISTS.

## Churches and Theatres With Fixed Seats.

Total load, 102 pounds per square foot.

Size of Joists.	Dist. on Centres.	White Pine.		Spruce or Norway Pine.		Oregon or Texas Pine.		Georgia Pine.	
		Ft.	Ins.	Ft.	Ins.	Ft.	Ins.	Ft.	Ins.
3x8	12	12	6	13	4	13	9	14	10
3x8	16	11	4	12	2	12	6	13	6
2x10	12	13	7	14	7	15	1	16	2
2x10	16	12	4	13	3	13	8	14	9
3x10	12	15	8	16	9	17	3	18	7
3x10	16	14	2	15	2	15	8	16	10
2x12	12	16	5	17	7	18	1	19	6
2x12	16	14	10	15	11	16	5	17	8
Total load, 105 pounds per square foot.									
3x12	12	18	7	19	11	20	6	22	1
3x12	16	16	10	18	1	18	7	20	1
2x14	12	19	0	20	3	20	10	22	6
2x14	16	17	3	18	5	19	0	20	6
2½x14	12	20	4	21	9	22	6	24	3
2½x14	16	18	7	19	10	20	6	22	1
3x14	12	21	8	23	2	23	10	25	9
3x14	16	19	8	21	1	21	9	23	4



TABLE XII.

MAXIMUM SPAN FOR FLOOR JOISTS.

Assembly Halls and Corridors.

Total load, 123 pounds per square foot.

Size of Joists.	Dist. on Centres.	White Pine.		Spruce or Norway Pine.		Oregon or Texas Pine.		Georgia Pine.	
		Ft.	Ins.	Ft.	Ins.	Ft.	Ins.	Ft.	Ins.
3x8	12	11	7	12	7	13	0	14	0
3x8	16	10	8	11	4	11	9	12	8
2x10	12	12	10	13	9	14	2	15	2
2x10	16	11	7	12	6	12	10	13	10
3x10	12	14	8	15	8	16	2	17	5
3x10	16	13	4	14	3	14	9	15	10
2x12	12	15	4	16	6	17	0	18	0
2x12	16	14	0	15	0	15	5	16	7
Total load, 126 pounds per square foot.									
3x12	12	17	6	18	8	19	3	20	9
3x12	16	15	10	17	0	17	7	18	11
2x14	12	17	10	19	1	19	8	21	2
2x14	16	16	2	17	4	17	11	19	3
2½x14	12	19	3	20	6	21	2	22	9
2½x14	16	17	6	18	8	19	3	20	9
3x14	12	20	5	21	9	22	6	24	3
3x14	16	18	7	19	10	20	6	22	1

TABLE XIII.

MAXIMUM SPAN FOR FLOOR JOISTS.

Retail Stores.

Total load, 174 pounds per square foot.

Size of Joists.	Dist. on Centres.	White Pine.		Spruce or Norway Pine.		Oregon or Texas Pine.		Georgia Pine.	
		Ft.	Ins.	Ft.	Ins.	Ft.	Ins.	Ft.	Ins.
3x8	12	11	6	12	5	14	1	14	9
3x8	16	9	11	10	2	12	2	12	9
2x10	12	11	8	12	8	14	5	15	1
2x10	16	10	2	10	11	12	5	13	1
3x10	12	14	4	15	6	17	7	18	7
3x10	16	12	5	13	5	15	2	16	0
2x12	12	14	1	15	2	17	2	18	2
2x12	16	12	2	13	1	14	11	15	8
Total load, 177 pounds per square foot.									
3x12	12	17	2	18	5	20	11	22	1
3x12	16	14	10	16	0	18	2	19	1
2x14	12	16	3	17	7	19	11	21	1
2x14	16	14	2	15	2	17	3	18	2
2½x14	12	18	2	19	7	22	3	23	6
2½x14	16	15	9	17	0	19	3	20	4
3x14	12	19	11	21	6	24	5	25	8
3x14	16	17	3	18	7	21	2	22	3

TABLE XIV.

MAXIMUM SPAN FOR RAFTERS.

## A. Shingled Roofs Not Plastered.\*

Total load, 48 pounds per square foot.

Size of Joists.	Dist. on Centres.	Hemlock.	White Pine.	Spruce or Norway Pine.	Oregon or Texas Pine.	Georgia Pine.	
		Ft. Ins.	Ft. Ins.	Ft. Ins.	Ft. Ins.	Ft.	Ins.
2x4	16	7 4	7 9	8 4	9 6	10	10
2x4	20	6 7	6 10	7 6	8 6	8	10
2x6	10	11 1	11 7	12 6	14 2	15	0
2x6	20	9 11	10 4	11 2	12 8	13	4
3x6	16	13 7	14 2	15 3	17 5	18	3
3x6	20	12 2	12 8	13 8	15 7	16	4
2x8	16	14 9	15 6	16 8	18 11	20	0
2x8	20	13 3	13 10	14 11	16 11	17	10
2x8	24	12 1	12 7	13 7	15 6	16	3
2x10	16	18 6	19 3	20 10	23 8	25	0
2x10	20	16 7	17 3	18 8	21 2	22	3
2x10	24	15 1	15 9	17 0	19 3	20	4

## B. Slate Roofs Not Plastered, or Shingle Roofs Plastered.\*

Total load, 57 pounds per square foot.

Size of Joists.	Dist. on Centres.	Hemlock.	White Pine.	Spruce.	Oregon Pine.	Georgia Pine.	
		Ft. Ins.	Ft. Ins.	Ft. Ins.	Ft. Ins.	Ft.	Ins.
2x4	16	5 9	7 1	7 7	8 8	9	2
2x4	20	6 0	6 4	6 9	7 9	8	2
2x6	16	10 2	10 7	11 6	13 0	13	8
2x6	20	9 1	9 6	10 2	11 7	12	3
3x6	16	12 6	13 0	14 1	15 11	16	9
3x6	20	11 1	11 8	12 7	14 3	15	0
2x8	16	13 7	14 2	15 3	17 4	18	3
2x8	20	12 2	12 8	13 8	15 6	16	4
2x8	24	11 1	11 7	12 6	14 2	14	11
3x8	16	16 7	17 4	18 9	21 3	22	5
3x8	20	14 10	15 6	16 9	19 0	20	1
3x8	24	13 7	14 2	15 3	17 4	18	4
2x10	16	17 0	17 8	19 2	21 7	22	10
2x10	20	15 2	15 10	17 1	19 4	20	6
2x10	24	13 10	14 6	15 7	17 8	18	8

TABLE XIV.—(Continued).

MAXIMUM SPAN FOR RAFTERS.

C. Slate Roofs Plastered, or Gravel Roofs Not Plastered.\*

Total load, 66 pounds per square foot.

Size of Joists.	Dist. on Centres.	Hemlock.	White Pine.	Spruce or Norway Pine.	Oregon or Texas Pine.	Georgia Pine.	
	Ins.	Ft. Ins.	Ft. Ins.	Ft. Ins.	Ft. Ins.	Ft.	Ins.
2x6	16	9 5	9 10	10 8	12 1	12	9
2x6	20	8 6	8 10	9 6	10 9	11	5
3x6	16	11 7	12 1	13 1	14 10	15	7
3x6	20	10 4	10 10	11 8	13 3	14	0
2x8	16	12 7	13 2	14 2	16 2	17	0
2x8	20	11 3	11 9	12 9	14 5	15	2
2x8	24	10 3	10 9	11 7	13 2	13	10
3x8	16	15 5	16 1	17 5	19 9	20	10
3x8	20	13 9	14 5	15 3	17 8	18	8
3x8	24	12 7	13 2	14 2	16 2	17	0
2x10	16	15 9	16 6	17 9	20 2	21	3
2x10	20	14 1	14 8	15 11	18 0	19	0
2x10	24	12 10	13 5	14 6	16 6	17	5
2x12	16	18 10	19 9	21 4	24 2	25	6
2x12	20	16 10	17 8	19 1	21 8	22	10
2x12	24	15 5	16 1	17 5	19 9	20	10

\* These tables are intended for climates where a snow fall of 2 feet may be expected. In the Southern States, where there is no snow to speak of, the spans in the first section will be safe for slate or gravel roofs if the joists are sawn full to dimensions.



# INDEX.

## A

Anchors, wall, for floor joists, 64; specifications for.....	478
Angle beads, 282; specifications for.....	486
Annual rings in wood.....	11
Area walls, framing for.....	438
Asbestos sheathing paper.....	207

## B

Back plastering, preparation for... ..	211
Balances, sash, 395; specifications for.....	496
Balconies, 421; see also galleries..	
Balloon framing.....	48
Balusters, stair.....	303
Balustrades for porches.....	182
Band mould.....	240
Base around rooms, 275; specifications for.....	485
Bastard sawing.....	25
Bay windows.....	129
Beams, ceiling, 283; specifications for.....	486
Beams, floor, framing of, see floor joists; maximum span for.....	531
Beams, wooden, strength of.....	528
Bearing plates.....	431
Bed mould.....	240
Bedsteads, dimensions of.....	313
Bent wood.....	24
Belt courses, wooden.....	174
Birch.....	41
Black walnut.....	43
Blind trimmings, outside, 404; specifications for.....	474
Blinds, outside, specifications for..	474
Bolles' patent revolving sash.....	123
Bolts, common, kinds and sizes..	328
Bolts, door, 379; cost of, 414; extension, 382; flush.....	381
Bommer spring hinges, 339; cost of.....	412
Bower-Barff finish.....	330
Bowled floors, construction of.....	419
Box casing.....	117
Box cornice.....	154
Box frames, 115; specifications for..	482
Braced frame, wooden buildings, 47; specifications for.....	466
Bracing of posts and girders.....	436

Brass.....	330
Brick mould.....	116
Brick buildings, floors in, 61; specifications for.....	476
Bridging of floor joists, 58; specifications for.....	466
Bridging of partitions.....	84
Broad leaved woods.....	39
Bronze, 330; finishes of.....	331
Bulkhead over cellar stairs, 147; specifications for.....	473
Bureaus, dimensions of.....	313
Butler's pantry, fittings for, 305; specifications for.....	480
Butternut.....	41
Butt joints.....	330
Butts, 334; cost of, 411; double-action, 338; sizes of, 337; specifications for.....	493
Byrkit's patent sheathing lath.....	212

## C

Cabot's Sheathing Quilt.....	178, 206
Casement windows, 125; hardware for, 400, 497; specifications for, 473	473
Cast iron columns and posts, details of, 433; strength of.....	525
Cedar, varieties of.....	37
Cedar closet, fittings for, 305; specifications for.....	480
Ceiling, wood.....	279
Ceiling beams, 283; maximum span for, 530; specifications for.....	486
Ceilings under flat roofs.....	216
Cellar window frames... ..	108, 473, 481
Chain bolts, 381, 383; prices of ..	414
Chair rail.....	28
Chairs and seats, dimensions of... ..	312
Characteristics and properties of wood.....	9
Cherry.....	41
Chestnut.....	42
Chimneys, flashing of, 199; furring around, 218; in outside walls... ..	218
China closet, fittings for, 305; specifications for.....	480
Clapboards, 175; specifications for, 471	471
Closets, fittings for, 305; specifications for.....	490
Clothes chute.....	307
Clothes hooks.....	411, 415
Coach screws.....	328

- Coal chute, construction of..... 107  
 Coat and hat hooks, 411; cost of... 415  
 Coiling partitions..... 502  
 Columns, cast iron, details of, 433; strength of..... 526  
 Columns, gas pipe, 434; strength of..... 527  
 Columns, ornamental, built up... 285  
 Columns, wooden, details of connections, 428; strength of.... 524  
 Composition roof, specifications for 498  
 Compound wooden girders..... 444  
 Conductor heads..... 166  
 Conductors metal, 165; specifications for, 470; waste from, 166; wooden..... 164  
 Conductors carried inside of the walls..... 167  
 Connection of floor joists and girders..... 435  
 Construction, mill..... 454  
 Construction, heavy..... 419  
 Construction of bell-shaped roofs, 99; of brick buildings, 61; of conical roofs, 98; of curb and mansard roofs, 96; of stairs, 293; of Windows, 112; of wooden buildings, 47; of wooden floors, 54, 61; of wooden roofs, 87, 91, 96  
 Copper roofs..... 21  
 Corner beads, 222; metal, 223; specifications for..... 475  
 Corner boards..... 174  
 Cornice construction..... 151, 164  
 Cornices, interior wooden, 285; specifications for..... 486  
 Cost of glass, 138, 141, 142; of hardware trimmings, 411; of inside blinds and shutters, 274; of mouldings, 241; of various woods..... 45  
 Counterflashing, 199; specifications for..... 470  
 Cross-furring, 215; specifications for..... 475  
 Crushing strength of timber, longitudinally, 523, 524; perpendicular to the grain..... 525  
 Crystal sheet glass..... 139  
 Cupboard catches and turns... 409, 415  
 Cupboard doors, 308; trimmings for..... 409, 415, 497  
 Curb roofs, 88, 93; construction of, 96  
 Custom made doors..... 247  
 Cutler mailing system..... 520  
 Cylinder locks..... 365  
 Cypress..... 39
- D
- Deafening materials..... 206  
 Deafening of floors..... 205  
 Deck mouldings..... 195  
 Decay of timber..... 30  
 Details of casement windows, 125; of cellar windows, 108; of column connections, 428, 433; of cupboards, drawers and book cases, 307; of door frames, exterior, 144; interior, 251; of double-hung window frames, 112, 115; of floor construction, brick buildings, 64; wooden buildings, 51; of framing, 51; of inside blinds and shutter, 262, 266; of mill construction, 455; of mullion and transom windows, 118; of outside finish, 151; of roof construction (wooden), 91; of skylights, 157; of store fronts... 133  
 Dimensions of furniture, seats, etc., 312  
 Distinction between hard and soft woods..... 13  
 Door bolts, 379; prices of..... 414  
 Door checks, 388; prices of..... 414  
 Door finish (casings, etc.)..... 253  
 Door frames, exterior, 144; securing to wall, 146; specifications for..... 475, 482  
 Door frames, interior, details of, 251; specifications for..... 484  
 Door knobs, spindle and escutcheons..... 368  
 Door stops or bumpers..... 486  
 Doors, balanced, pulleys for..... 352  
 Doors, custom made, 247; double, 246; Dutch, 247; O. G. doors, 245; patented, 250; revolving, 512; rolling or coiling, 505; sliding, 246; veneered..... 248  
 Doors, folding, methods of hanging..... 350  
 Doors for cupboards, book cases, etc..... 308  
 Doors, hardware for..... 332  
 Doors, specifications for..... 484  
 Dormers, construction of, 99; outside finish of, 186; types of.... 185  
 Double-action doors, frames for, 253; hardware for, specifications for... 495  
 Double-action hinges, 338; prices of..... 412  
 Double doors..... 246  
 Double-hung windows, details of, 112, 115; specifications for... 473, 482  
 Dovetailing..... 234  
 Drawer pulls..... 410  
 Drawers, details of, 309; specifications for..... 490  
 Dresser, kitchen, 306; specifications for..... 489

- Druggist's drawer pulls..... 410  
 Dry rot..... 31  
 Dryness of woods, measure of..... 20  
 Dumb waiters, fixtures for, 516;  
 shaft for..... 307  
 Duplex joist hangers, 68; wall  
 hangers..... 66
- E
- Eaves and gutters, details of, 151;  
 specifications for..... 467  
 Eave trough hangers..... 157  
 Eave troughs..... 157  
 Effect of shrinkage in timber..... 22  
 Effect of tapping pitch pine..... 36  
 Elm..... 42  
 Enclosing the building..... 226  
 End connections of columns..... 434  
 Escutcheon plates..... 372  
 Espagnolette bar..... 401  
 Extension bolts, 382; prices of.... 414  
 Exterior finish, 151; specifications  
 for..... 467
- F
- Fascia..... 152  
 Felt papers..... 177, 207  
 Finish, detailing of..... 241  
 Finished hardware, 328; butts, 374;  
 door bolts, 379; door checks,  
 388; hinges, 332; locks, 352;  
 materials and finish, 328; prices  
 of, 411; sets, 373; sliding door  
 hangers, 342; transom fixtures... 383  
 Finished hardware, for casement  
 windows, 400; for cupboard  
 doors, 409; for doors, 332; for  
 outside blinds, 404; for screen  
 doors, 385; for shutters, 403; for  
 water closet doors, 386; for win-  
 dows..... 390  
 Finishes of hardware..... 329  
 Finishing woods..... 39, 227  
 Fire stops..... 86, 210  
 Fittings and fixtures..... 304  
 Fittings for dumb waiters..... 516  
 Fixtures and fittings..... 304  
 Flashings, 195, 197; around win-  
 dow frames, 115; specifications  
 for..... 469, 498, 499  
 Flexifold partitions..... 509  
 Flitch plate girders, 71; safe load  
 for..... 71  
 Floor beams, maximum span for  
 (tables)..... 531  
 Floor joists, bridging of, 58; fram-  
 ing to girders, 56, 59; framing  
 to sill, 55; spacing of, 55; speci-  
 fications for, 466, 477; wall sup-  
 port for..... 64  
 Flooring, upper, parquetry, 318;  
 qualities of, 315; specifications  
 for..... 491  
 Floors, bowled, construction of.... 419  
 Floors, deafening of..... 205  
 Floors, framing of, in brick build-  
 ings, 61; in wooden buildings... 54  
 Floors, porch, framing of..... 58  
 Floors supported by rods and  
 trusses..... 440  
 Floors with independent ceiling  
 joists..... 75  
 Floors, under, 204; specifications  
 for..... 475  
 Floors, upper, 313; laying and  
 nailing of, 316; of hard wood,  
 314, 317; of parquetry, 318;  
 specifications for..... 491  
 Flour bins..... 306  
 Flush bolts, 381; prices of..... 414  
 Folding doors, hanging..... 350  
 Frames, cellar window, 108; coal  
 chute, 107; door, 144; window.. 108  
 Frames, specifications for..... 473,  
 475, 481, 482, 484  
 Framing a projecting corner..... 59  
 Framing around stair wells, chim-  
 neys, etc..... 57  
 Framing for area walls..... 438  
 Framing of conical roofs, 98; of  
 galleries, 421, 423; of joiner's  
 work, 236; of porch floors, 58;  
 of stores and warehouses, 426;  
 specifications for..... 500  
 Framing of floors in brick build-  
 ings..... 61  
 Framing of floors in wooden build-  
 ings, 54; details of..... 55  
 Framing of header and trimmer,  
 57; with hangers or stirrups, 67;  
 with tenon and tusk joint..... 56  
 Framing of joists to girder, 56, 59;  
 of joists to sill..... 55  
 Framing of wooden buildings,  
 floors, 54; laying out of, 60; out-  
 side walls, 47, 51; roof..... 87  
 Framing, specifications for... 466,  
 477, 500  
 Framing timber, common sizes, 47;  
 specifications for, 465; technical  
 terms..... 46  
 French windows, details of, 125;  
 hardware for, 401; specifications  
 for..... 473, 494  
 Front door locks, 362; prices of... 413  
 Furniture, dimensions of..... 312  
 Furring, 214; around chimneys,  
 218; for cornices, 220; for false  
 beams and arches, 220, 221; for

round corners, 220; of ceilings,  
215; of walls..... 217  
Furring, specifications for.... 475, 482

## G

Gable finish..... 167  
Galleries, framing of, 421; hung  
with, 443; with heavy projec-  
tion..... 425  
Galvanized iron gutters..... 157  
Gambrel roofs..... 88, 93  
Gas pipe columns, 434; strength of, 527  
Gauge, American screw..... 327  
Girders, built up, 73; compound  
wooden, 444; flitch plate, 71;  
steel beam, 74; trussed..... 449  
Girders, framing of joists to... 56,  
59, 69, 72, 435  
Glass, 136; cost of, 138, 141; crys-  
tal sheet, 139; plate, 140; sheet,  
137; special brands of, 139;  
specifications for, 474; weight of,  
394  
Glass knobs, 371; prices of..... 414  
Glazing..... 136  
Goetz box anchors..... 66  
Goetz joist hangers..... 68  
Goetz post caps..... 430  
Goose necks..... 166  
Grain of wood..... 13  
Gravel roofs, specifications for... 498  
Grounds, 221; specifications for...  
475, 482  
Growth of trees..... 11  
Gum wood..... 42  
Gutters, 151; specifications for,  
468, 470; tin and galvanized  
iron, 157; tin lined, 156; wooden, 152

## H

Hand of door..... 336  
Hangers for sliding doors..... 342  
Hard and soft woods, distinction  
between..... 13  
Hard pine, 34; effect of tapping... 36  
Hard pine beams, strength of (table), 528  
Hard pine posts, strength of (table), 525  
Hard woods, description of..... 39  
Hardware, finished, 328; in sets,  
373; ornamental, 374; prices of,  
411; putting on, 415; rough, 323;  
specifications for, 417 (see also  
finished hardware).  
Hatchway, 147; specifications for, 473  
Heavy framing, chapter on, 419;  
specifications for..... 500  
Hemlock..... 37  
Heydebrand safety window..... 123  
Hinges, common, 332; double-

action, 338; spring, single action,  
385 (see also butts).  
Hinges for outside blinds..... 404  
Hip roof trussing..... 100  
Hips, finish of..... 193  
Hotel locks..... 365

## I

Imported woods..... 44  
Inside blinds, folding, 262; rolling,  
269; selection of, 274; sliding,  
266; specifications for, 486; Vene-  
tian..... 271  
Inside finish, 227 (see interior  
finish).  
Inside shutters..... 262  
Interior finish, cornices, beams and  
columns, 282; detailing of, 241;  
of doors, 253; of windows, 257;  
miscellaneous, 277; preparation  
of, 229; putting up, 259; specifi-  
cations for, 483; woods for..... 227

## J

Jamb casings..... 258  
Jambs, door, 251; panel..... 253  
Joiners' work..... 227  
Joining a wooden to a stone wall... 179  
Joining woodwork..... 230  
Joist hangers, Duplex, 64; Goetz,  
68; stirrups, 69; Van Dorn..... 71  
Joint bolts, in framing, 69; stair... 302  
Joints in joiners' work—butt joints,  
230; coped joints, 233; dovetail  
joints, 234; doveled and jeyed  
joints, 237; glued and blocked  
joints, 235; housed joints, 233;  
mitre joints, 232; tongue and  
grooved joints..... 231

## K

Keyed beams, rules for and strength  
of..... 446  
Kiln drying..... 19  
Kitchen dresser, 306; specifications  
for..... 489  
Kitchen pantry, fittings for, 306;  
specifications for..... 489  
Knobs and escutcheons, 368; cost  
of, 414; specifications for..... 495  
Knots, their effect on the strength  
of timber..... 29

## L

Lag screws..... 328  
Linen closet, fittings for..... 305



- Lintels over openings, specifications for ..... 479
- Locks, 352; construction and operation of, 352; cylinder, 365; front door, 362; grades of, 358; hotel, 263; master keyed, 362; office, 365; prices of, 412; rim, 352, 359; sliding door, 363; store door, 360; tumbler, 352; varieties of, 359; wrought metal ..... 357
- Locks, specifications for ..... 495
- Lookouts, 160; see Figs. 137, 141.
- Lumber, conversion of, 25; cost of, 45; measurement of, 28; merchant sizes, 27; quarter sawed, 26; see also timber.
- Lumber for framing, 46; specifications for ..... 465, 500
- M
- Mahogany ..... 44
- Mail chutes, the Cutler ..... 520
- Mansard roofs, 88, 93; construction of ..... 96
- Maple ..... 42
- Market prices of various woods ..... 45
- Master keyed locks, 364; prices of, 412
- Maximum span for ceiling joists ..... 530
- Maximum span for floor joists ..... 531
- Maximum span for rafters ..... 534
- Measure of dryness of woods ..... 20
- Medulary rays ..... 10
- Metal corner beads, 223; specifications for ..... 475
- Mice stops, 210; specifications for, 476
- Mill construction, 454; specifications for ..... 500
- Mineral wool ..... 208
- Mitre joints ..... 332
- Moisture in wood ..... 17
- Mouldings, cost of, 241; kinds of, 240; names of ..... 239
- Mullion frames ..... III, 118
- N
- Nails, 323; holding power of, 326; sizes of, 324; for different kinds of work ..... 325
- Night latches, 368; prices of ..... 413
- O
- Oak ..... 40
- Office locks, 367; prices of ..... 413
- Ogee (O. G.) doors ..... 245
- Ogee (O. G.) moulding ..... 235
- Operations in joinery ..... 229
- Ornamental hardware ..... 374
- Outside blinds, hanging and hardware for, 404; specifications for, 474
- Outside boarding, 106; specifications for ..... 467
- Outside finish of wooden buildings, 151; materials for, 151; specifications for ..... 467
- Outside frames, 107; specifications for ..... 473, 481, 482
- Outside walls of wooden buildings, framing of ..... 47
- Overhead pulleys for sash, 391; for doors ..... 352
- P
- Panel work ..... 279
- Paneled wainscoting, 277; specifications for ..... 485
- Panel backs ..... 259
- Panel jambs ..... 261
- Pantry, butler's, fittings for, 305, 489; kitchen, fittings for ..... 306, 489
- Paper, asbestos, 207; felt, 207; fireproof, 207; sheathing ..... 177
- Parquetry flooring ..... 318
- Parting strip ..... 115
- Partitions, 76; bridging of, 84; chimneys in, 218; flexifold, 509; hot air pipes in, 86; rolling, 505; sliding door, 85; solid corners in, 83; specifications for, 476; staggered, 85; superintendence of, 105; supports for, 76; trussed, 81; trussed over openings ..... 84
- Partitions in mill construction, details of ..... 460
- Patent doors ..... 250
- Patent windows ..... 123
- Piazzas, 179; specifications for, 47; see also porches.
- Picture moulding ..... 281
- Pine, varieties of ..... 33
- Pitch of roofs ..... 87, 95
- Pivoted windows, 127; hardware for ..... 402
- Planceer ..... 152
- Plinth blocks ..... 257
- Polishing interior finish ..... 229
- Poplar (whitewood) ..... 43
- Porch floors, framing of ..... 53
- Porches, construction and details of, 179; specifications for ..... 471, 48
- Post and girder construction ..... 427
- Post caps ..... 428
- Posts, strength of ..... 524
- Preparation for tile floors, 205; specifications for ..... 475
- Preservation of timber ..... 32
- Prices of hardware, 411; of various woods, 45; see also, cost.

- Projecting corners, framing of. . . . . 59  
 Properties of wood. . . . . 9  
 Pulleys for heavy doors. . . . . 351  
 Pulleys, sash, side pattern, 390;  
 overhead, 391; specifications for, 496
- Q
- Quarter sawed lumber. . . . . 26  
 Queen overhead pulleys. . . . . 392  
 Quirks. . . . . 239
- R
- Railing of porches and piazzas,  
 182; of stairs. . . . . 301  
 Raised mouldings. . . . . 240  
 Redwood. . . . . 38  
 Resonance of wood. . . . . 15  
 Revolving doors. . . . . 512  
 Revolving sash. . . . . 123  
 Ridges, finish of. . . . . 193  
 Rods, strength of. . . . . 524  
 Rolling blinds. . . . . 269  
 Rolling partitions. . . . . 505, 509  
 Roof boarding. . . . . 106  
 Roof bracing, simple method of. . . 101  
 Roof plan, laying out of. . . . . 89  
 Roofs, construction of, 87, 91, 96;  
 pitch of 87; types of. . . . . 88  
 Roofs in mill construction. . . . . 459  
 Rot in timber. . . . . 31
- S
- Sash, details of, 130; revolving,  
 123; specifications for, 474;  
 stock, 132, 142; store window,  
 133; weight of. . . . . 394  
 Sash adjusters. . . . . 402  
 Sash balances. . . . . 395  
 Sash bars. . . . . 134  
 Sash centres. . . . . 384, 401  
 Sash chains. . . . . 393  
 Sash cords. . . . . 393  
 Sash fastenings, 396; cost of 414;  
 specifications for. . . . . 496  
 Sash lifts, 399; cost of, 414; speci-  
 fications for. . . . . 496  
 Sash pulleys. . . . . 390  
 Sash pull plates or sockets. . . . . 400  
 Sash ribbons. . . . . 394  
 Sash weights. . . . . 394  
 Screen door trimmings. . . . . 385  
 Screws, kinds and sizes of. . . . . 326  
 Scribing. . . . . 238  
 Scuttles, 189; specifications for. . . 469  
 Seasoning of timber. . . . . 18  
 Seats, dimensions of. . . . . 312  
 Selection of timber for special pur-  
 poses. . . . . 29
- Shakes in wood. . . . . 25  
 Sheathing, 106; specifications for. . 467  
 Sheathing lath. . . . . 212  
 Sheathing papers, 177; under shing-  
 les on roof. . . . . 192  
 Shingled roofs, 190; specifications  
 for. . . . . 469  
 Shingles, 190; durability of, 192;  
 laying, 192; lining under. . . . . 192  
 Shrinkage of woods, 21; amount of,  
 16; effect of. . . . . 22  
 Shutters, inside, 262; hardware for,  
 403; specifications for. . . . . 486  
 Siding. . . . . 174, 175  
 Sink, carpenters' work around, 305;  
 specifications for. . . . . 490  
 Size of nails, 324; for different  
 kinds of work. . . . . 325  
 Sizing and crowning of floor joists. . 54  
 Skirting. . . . . 275  
 Skylights, wooden, 187; specifica-  
 tions for. . . . . 480  
 Slate roofing, specifications for. . . 499  
 Sliding blinds. . . . . 266  
 Sliding door partitions. . . . . 85  
 Sliding doors, 246; hangers for,  
 342; trimmings for. . . . . 363  
 Slow burning construction. . . . . 454  
 Smoothing and polishing interior  
 finish. . . . . 227  
 Soft pines. . . . . 33  
 Soft woods, distinction from hard  
 woods. . . . . 13  
 Solid wooden partitions. . . . . 460  
 Specifications, general conditions. . 464  
 Specifications, preface to chapter  
 on. . . . . 462  
 Specifications for the carpenters'  
 work of brick buildings. . . . . 476  
 Specifications for the carpenters'  
 work of frame buildings. . . . . 465  
 Specifications for doors, 483; for  
 flashing, 469; with gravel roofs,  
 498; with slate roofs, 499; for  
 flooring, 491; for framing of  
 brick buildings, 477; for fram-  
 ing of wooden buildings, 466;  
 for framing lumber, 465; for  
 glass, 474; for gravel roofing,  
 498; for grounds and furring in  
 brick buildings, 482; in frame  
 buildings, 475; for hardware,  
 417, 493; for interior finish, 483;  
 for mill construction, 500; for  
 outside wood finish, 467; for  
 pantries and closets, 489; for par-  
 titions, 476; for piazza and porch,  
 471, 480; for shingle roofing,  
 469; for siding and clapboards,  
 471; for slate roofing, 499; for  
 stairs, 487; for tin roofing, 470,

- for trusses, 501; for wainscoting, 485; for windows in brick buildings, 481; in frame buildings... 473  
 Splined joints..... 237  
 Spring butts, double-action, 338; single-action..... 385  
 Spruce..... 36  
 Spruce beams, strength of (table)... 529  
 Staff bead..... 116  
 Staggered partitions..... 85  
 Stairs, 286; construction of, 293; definitions, 287; laying out of, 288; public, width of, 293; railing, posts and balusters, 301; specifications for..... 487  
 Steam pipe columns, 434; strength of..... 527  
 Steel beam girders..... 74  
 Stiffening a weak floor..... 75  
 Stirrup irons, 69; sizes and strength of..... 70  
 Stock doors..... 243  
 Stock mouldings..... 241  
 Stock windows..... 142  
 Stop adjusters..... 400  
 Stops for fire and mice..... 210  
 Store door locks, 360; prices of... 413  
 Store fronts and windows, 133; specifications for..... 503  
 Storm windows or sash, specifications for..... 474  
 Storm window fastenings..... 408  
 Strength of cast iron columns (table)..... 526  
 Strength of hard pine beams (table), 528  
 Strength of hard pine posts (table), 525  
 Strength of iron and steel rods... 524  
 Strength of spruce beams (table)... 529  
 Strength of stirrup irons..... 71  
 Strength of stones..... 523  
 Strength of timber, 523, 528; as affected by its physical characteristics..... 28  
 Strength of wooden beams, formulæ, 528; tables..... 528, 529  
 Strength of wooden posts..... 524  
 Sub-jambes or jamb casings..... 117  
 Superintendence of hardware, 415; of interior finish, stairs and upper floors, 319; of outside finish and shingle roofs, 201; of outside windows and door frames, 149; of wood framing..... 102  
 Suspended ceilings under flat roofs, 216  
 Sycamore..... 43
- T
- Tables, dimensions of..... 312  
 Tenon and mortise joint in joiners' work, 236, 247; in wood framing..... 56  
 Thickness of rough and finished lumber..... 243  
 Tile floors, preparation for, 205; specifications for..... 475  
 Timber, conversion of, 25; cost of, 45; decay of, 30; measurement of, 28; merchant sizes of, 27; preservation of, 32; seasoning of, 18; selection of for special purposes, 29; shakes in, 25; shrinkage of, 21, 24; strength of, 523; as affected by physical characteristics, 28; varieties of, used in the United States..... 33  
 Timber for framing, 30; specifications for..... 465, 500  
 Tin roofs, 200; specifications for.. 470  
 Trackless hangers..... 347  
 Transom fixtures or trimmings, 383; prices of, 414; specifications for, 495  
 Transom frames, 111, 118; with single light below..... 110, 120  
 Traversing..... 316  
 Trees, 9; annual rings in, 11; coniferous, 33; exogenous, 9; growth of..... 11  
 Trussed girders..... 449  
 Trusses, specifications for..... 501  
 Types of roofs..... 88  
 Types of windows..... 109
- U
- Under floors, 204; specifications for..... 475  
 Upper floors, 313; specifications for..... 491
- V
- Van Dorn joist hangers and post caps..... 70, 431, 436  
 Van Kannel revolving doors, the.. 512  
 Varieties of timber used in the United States..... 33  
 Varieties of tumbler locks..... 359  
 Veneered work..... 238, 248, 279  
 Venetian blinds..... 271  
 Ventilating sash bolts, 398; prices of..... 415  
 Verge boards..... 170  
 Vestibule door locks, 362; prices of, 413
- W
- Wainscoting, matched, 279; paneled, 277; specifications for... 485  
 Wall anchors for joists, 64; specifications for..... 478

- Wall covering, clapboards and siding, 174; shingles, 176; specifications for..... 471
- Wall plate for brick or stone buildings..... 67
- Walnut..... 43
- Wards..... 354
- Washers for butts..... 337
- Waste from conductors..... 166
- Water closet doors, hardware for.. 386
- Water table, wooden, 173; specifications for..... 468
- Weight of timber, 16, 523; of sash and glass, 394; of structural materials..... 523
- Weight of wood, as affecting its strength..... 29
- Whitewood..... 43
- Width of public stairs..... 293
- Wilson's rolling blinds..... 271
- Wilson's rolling partitions..... 507
- Window glass and glazing, 136; specifications for..... 474
- Window frames, casement, 125; cellar, 108; details of, 108, 112; double-hung, 112; pivoted, 127; specifications for, 473, 481; transom..... 111, 118
- Window hardware, 390; prices of, 414; specifications for..... 494
- Windows, bay, 129; revolving, 123; stock, 142; store, 133; types of, 109
- Wood framing, 47; see framing.
- Wooden beams, strength of..... 528
- Wooden buildings, covering of, 174; framing of, floors, 54; outside walls, 47; roof, 89; specifications for..... 465
- Wooden cornices, exterior, 153; specifications for..... 467
- Wooden cornices (interior), ceiling beams, columns, etc., 282; specifications for..... 486
- Wooden posts, details of, 427; strength of..... 524
- Wooden skylights, 187; specifications for..... 480
- Woods, characteristics and properties of, 9; color and odor of, 14; distinction between hard and soft, 13; imported, 44; moisture in, 17; prices of, 45; resonance of, 15; shrinkage of, 21, 24; varieties of 33; weight of...16, 523
- Woods, finishing, 227; specifications for..... 483

## Y

Yoke, see Fig. 96..... 114

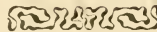

---

WE MAKE AND SELL  
**DOOR HANGERS.**

**Le Roy Noiseless,** Ball Bearing, with adjustable track.

(See description Page 343 )

**Wilcox Trolley,** Ball Bearing, with adjustable track.

**Wideman Narrow Gauge,** Trolley, Ball Bearing with adjustable track.

RICHARD'S IMPROVED

RICHARD'S STEEL, SINGLE TRACK.

WILCOX NEW CYCLE, BALL BEARING.

Wilcox Velvet (wood track, held by U-shaped channel.)

Wilcox Trolley, roller bearing,—Steel Barn and Fire Door Hangers.

Wilcox Trolley, Roller Bearing,—Steel Pier and Warehouse Door Hangers.

WILCOX AUTOMATIC FIRE DOOR FIXTURES, (<sup>FOUR</sup> STYLES)

Made in accordance with underwriters' specifications.

WILCOX OVER HEAD CARRYING SYSTEM

AUDITORIUM HANGERS FOR FOLDING and SLIDING DOORS.

All goods guaranteed to be perfect in construction.

Write for blue prints and complete illustrated catalogue.

WILCOX M'F'G CO.,

AURORA, ILL.

# USE PEARSON'S CEMENT COATED WIRE NAIL

---

Unequaled for general building purposes  
They drive easier, hold 75% stronger, last longer  
and cost no more.

Ask your dealer or write

**J. C. PEARSON CO.**

Board of Trade Building. BOSTON, MASS.

---

## Cabot's Insulating and Deafening Quilt

PATENTED 1892-93.

A soft, resilient cushion of dead air spaces, giving the most perfect conditions for absorbing and dissipating sound waves. Light, cheap and indestructible by decay—can be used in place of heavy and expensive construction. Immensely superior to the ordinary thin, dense felts and papers. Send for sample.

**SAMUEL CABOT, Sole Manufacturer, 70 Kilby St., Boston, Mass.**

*Agents at all Central Points.*

---

**F. E. KIDDER,**  
**CONSULTING ARCHITECT,**  
**Structural and Fireproofing Engineer.**  
628 FOURTEENTH STREET, DENVER, COLO.

Expert advice and assistance on all forms of building construction; selection of fireproofing systems, detailing of steel and wooden trusses, etc. **Prompt attention given to consultations by mail. Special prices given when desired.**

During 20 years practice as a consulting Architect, I have rendered assistance to leading Architects and Builders, from Maine to California.



Joist Hanger for all sizes up to 8x16

**FOR**  
**First Class**  
**Construction**

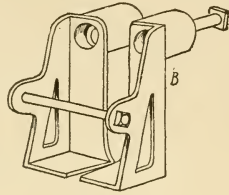

Hangers for joists over 8 ins. wide.

**USE**

**DUPLEX-JOIST HANGERS, WALL HANGERS AND POST CAPS**

**STRONG, ECONOMICAL,** reduce the effect of **shrinkage one-half,** and have many other advantages over stirrup hangers. Specified by the leading Architects and Engineers and used in every State.

A large stock of all sizes, including 45° hangers carried at Cleveland and various agencies. For prices, circulars, reports of tests, etc., address

**THE DUPLEX HANGER CO., Cleveland, Ohio.**

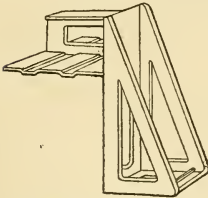

Wall Hanger for joists 6x14 and under. Self releasing, no holes in wall.

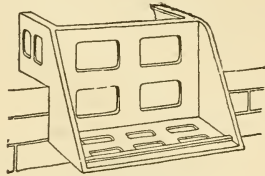

Extra Heavy Wall Hanger Nothing equal to it for heavy construction.

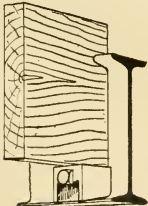

I-beam bracket, strong and cheap. Various sizes.



I-beam Hanger.

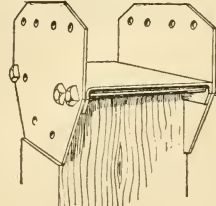

Two-way Post Cap. All steel. Three-way and four-way caps also carried in stock.

# ANTIHYDRINE

**DAMP-PROOF AND STAIN PROOF COATING**

THE ORIGINAL MATERIAL  
FOR MAKING WALLS DAMP-  
PROOF AND STAIN-PROOF.

Address: **ANTIHYDRINE CO.**  
**New Haven, Conn.**

---

## The Architects' and Builders' Pocket Book

By F. E. KIDDER, C. E., Ph. D., F. A. I. A.

PUBLISHED BY

**JOHN WILEY & SONS,**

43 & 45 East 19th Street,      \*      \*      \*      New York.

FOURTEENTH EDITION.

1656 Pages, 1000 engravings.

Morocco. Price \$5.00.

Without question the leading Architects' and Builders' "Hand Book" in the United States, and the best practical work published treating of the strength of materials and structures.

---

# F. E. KIDDER,

## CONSULTING ARCHITECT,

### Structural and Fireproofing Engineer,

**628 FOURTEENTH STREET, DENVER, COLO.**

Expert advice and assistance on all forms of building construction; selection of fireproofing systems, detailing of steel and wooden trusses, etc. Prompt attention given to consultations by mail. Special prices given when desired.

During 20 years practice as a consulting Architect, I have rendered assistance to leading Architects and Builders, from Main to California.





JAS. F. BIGELOW,  
CIVIL ENGINEER,  
COREY BUILDING,  
MARTIN, MASS.

DO NOT CIRCULATE

3 1430 02617437 7



a 31430026174377 b

UNIV. OF MD. COLLEGE PARK

3754

