

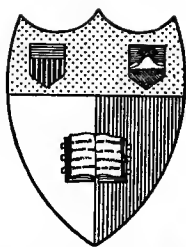

TP 244 .H9  
T24



**Cornell University Library**  
Ithaca, New York

BOUGHT WITH THE INCOME OF THE  
SAGE ENDOWMENT FUND

THE GIFT OF  
HENRY W. SAGE

1891  
CHEMISTRY LIBRARY

Cornell University Library  
**TP 244.H9T24**

**Industrial hydrogen,**



3 1924 004 527 549

pk73

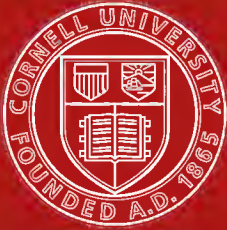

## Cornell University Library

The original of this book is in  
the Cornell University Library.

There are no known copyright restrictions in  
the United States on the use of the text.

# INDUSTRIAL HYDROGEN

BY

HUGH S. TAYLOR, D.Sc.

ASSOCIATE PROFESSOR OF PHYSICAL CHEMISTRY,  
PRINCETON UNIVERSITY



American Chemical Society  
Monograph Series

*BOOK DEPARTMENT*

*The* CHEMICAL CATALOG COMPANY, *Inc.*

ONE MADISON AVENUE, NEW YORK, U. S. A.

1921

h

A508385

COPYRIGHT, 1921, BY

*The* CHEMICAL CATALOG COMPANY, *Inc.*

*All Rights Reserved*

Press of  
J. J. Little & Ives Company  
New York, U. S. A.

## GENERAL INTRODUCTION

### American Chemical Society Series of Scientific and Technologic Monographs

By arrangement with the Interallied Conference of Pure and Applied Chemistry, which met in London and Brussels in July, 1919, the American Chemical Society was to undertake the production and publication of Scientific and Technologic Monographs on chemical subjects. At the same time it was agreed that the National Research Council, in cooperation with the American Chemical Society and the American Physical Society, should undertake the production and publication of Critical Tables of Chemical and Physical Constants. The American Chemical Society and the National Research Council mutually agreed to care for these two fields of chemical development. The American Chemical Society named as Trustees, to make the necessary arrangements for the publication of the monographs, Charles L. Parsons, Secretary of the American Chemical Society, Washington, D. C.; John E. Teeple, Treasurer of the American Chemical Society, New York City; and Professor Gellert Alleman of Swarthmore College. The Trustees have arranged for the publication of the American Chemical Society series of (a) Scientific and (b) Technologic Monographs by the Chemical Catalog Company of New York City.

The Council, acting through the Committee on National Policy of the American Chemical Society, appointed the editors, named at the close of this introduction, to have charge of securing authors, and of considering critically the manuscripts prepared. The editors of each series will endeavor to select topics which are of current interest and authors who are recognized as authorities in their respective fields. The list of monographs thus far secured appears in the publisher's own announcement elsewhere in this volume.

The development of knowledge in all branches of science, and

especially in chemistry, has been so rapid during the last fifty years and the fields covered by this development have been so varied that it is difficult for any individual to keep in touch with the progress in branches of science outside his own specialty. In spite of the facilities for the examination of the literature given by Chemical Abstracts and such compendia as Beilstein's *Handbuch der Organischen Chemie*, Richter's *Lexikon*, Ostwald's *Lehrbuch der Allgemeinen Chemie*, Abegg's and Gmelin-Kraut's *Handbuch der Anorganischen Chemie* and the English and French Dictionaries of Chemistry, it often takes a great deal of time to coordinate the knowledge available upon a single topic. Consequently when men who have spent years in the study of important subjects are willing to coordinate their knowledge and present it in concise, readable form, they perform a service of the highest value to their fellow chemists.

It was with a clear recognition of the usefulness of reviews of this character that a Committee of the American Chemical Society recommended the publication of the two series of monographs under the auspices of the Society.

Two rather distinct purposes are to be served by these monographs. The first purpose, whose fulfilment will probably render to chemists in general the most important service, is to present the knowledge available upon the chosen topic in a readable form, intelligible to those whose activities may be along a wholly different line. Many chemists fail to realize how closely their investigations may be connected with other work which on the surface appears far afield from their own. These monographs will enable such men to form closer contact with the work of chemists in other lines of research. The second purpose is to promote research in the branch of science covered by the monograph, by furnishing a well digested survey of the progress already made in that field and by pointing out directions in which investigation needs to be extended. To facilitate the attainment of this purpose, it is intended to include extended references to the literature, which will enable anyone interested to follow up the subject in more detail. If the literature is so voluminous that a complete bibliography is impracticable, a critical selection will be made of those papers which are most important.

The publication of these books marks a distinct departure in the policy of the American Chemical Society inasmuch as it is a



serious attempt to found an American chemical literature without primary regard to commercial considerations. The success of the venture will depend in large part upon the measure of co-operation which can be secured in the preparation of books dealing adequately with topics of general interest; it is earnestly hoped, therefore, that every member of the various organizations in the chemical and allied industries will recognize the importance of the enterprise and take sufficient interest to justify it.

## AMERICAN CHEMICAL SOCIETY

## BOARD OF EDITORS

## Scientific Series:—

WILLIAM A. NOYES, *Editor*,  
GILBERT N. LEWIS,  
LAFAYETTE B. MENDEL,  
ARTHUR A. NOYES,  
JULIUS STIEGLITZ.

## Technologic Series:—

JOHN JOHNSTON, *Editor*,  
C. G. DERICK,  
WILLIAM HOSKINS,  
F. A. LIDBURY,  
ARTHUR D. LITTLE,  
C. L. REESE,  
C. P. TOWNSEND.

---

American Chemical Society

MONOGRAPH SERIES

Other monographs in the series of which this book is a part are now ready or in process of being printed or written. They will be uniform in size and style of binding. The list up to July First, 1921, includes:

**Organic Compounds of Mercury.**

By FRANK C. WHITMORE. 397 pages. Price \$4.50.

**The Chemistry of Enzyme Actions.**

By K. GEORGE FALK. 140 pages. Price \$2.50.

**The Chemical Effects of Alpha Particles and Electrons.**

By SAMUEL C. LIND. 180 pages. Price \$3.00.

**The Animal as a Converter.**

By HENRY PRENTISS ARMSBY.

**The Properties of Electrically Conducting Systems.**

By CHARLES A. KRAUS. About 400 pages, illustrated.

**Carotinoids and Related Pigments: The Chromolipins.**

By LEROY S. PALMER. About 200 pages, illustrated.

**Thyroxin.** By E. C. KENDALL.

**The Properties of Silica and the Silicates.**

By ROBERT S. SOSMAN. About 500 pages, illustrated.

**Coal Carbonization.** By HORACE C. PORTER.

**The Corrosion of Alloys.** By C. G. FINK.

**The Vitamines.** By H. C. SHERMAN. About 200 pages.

**Piezo-Chemistry.** By L. H. ADAMS. About 350 pages.

**Cyanamide.** By JOSEPH M. BRAHAM.

**Liquid Ammonia as a Solvent.** By E. C. FRANKLIN.

**Wood Distillation.** By L. F. HAWLEY.

**Shale Oil.** By RALPH H. MCKEE.

**Aluminothermic Reduction of Metals.** By B. D. SAKLAT-WALLA.

**The Analysis of Rubber.** By JOHN B. TUTTLE.

**Zirconium and Its Compounds.** By F. P. VENABLE.

**The Chemistry of Leather Manufacture.** By JOHN A. WILSON. About 400 to 500 pages.

For additional information regarding this series of monographs, see General Introduction, page 3. As the number of copies of any one monograph will be limited, advance orders are solicited.

*The* CHEMICAL CATALOG COMPANY, Inc.  
ONE MADISON AVENUE, NEW YORK, U. S. A.

---

## AUTHOR'S PREFACE

The present monograph outlines the fundamental principles and essential chemical facts of the industry of hydrogen production. It attempts to trace the steps by which the present status of the industry has been reached, to detail what that present status is and what lines of future development may be anticipated. The two-fold purpose of the monograph series, as outlined by the Board of Editors, has been kept steadily in mind. It is hoped that a readable account has been given of available knowledge and that, in many directions, the necessity for more research and experimental investigation has been indicated.

Modern chemical technology demands the intelligent cooperation of the chemist and the engineer. The attempt to eliminate the one or the other from the development of a new process, generally results in retarded progress. Nor is anything gained by the intrusion of the one into the legitimate field of the other; indeed, the results of such intrusion are, quite frequently, ludicrous. Consequently, the chemical side of the problems of hydrogen technology is here emphasized. It is thought, however, that the necessary data have been supplied upon which an engineering staff could readily base its calculations for actual plant details.

The problem of cost factors in a technical monograph is a difficult one, upon which most diverse views are current. No extended discussion of costs is to be found in the following pages, a decision which was reached as a result of the rapidly varying prices in fuel, labor and machinery in recent years and of the varying factors of cost, arising from location of plant and availability and selling costs of the by-products of several hydrogen processes. It has been attempted, however, to supply in all cases the necessary data upon which such cost calculations can be made. Indeed, such an exercise has been undertaken and carried through several times in recent years, in varying circumstances, with the data here assembled.

The monograph differs in size and in plan from those books

dealing with the subject which have preceded it. The literature of the subject has been critically examined and, in the light of accumulated knowledge, much that has been previously claimed, in patents and otherwise, has been discarded as impracticable. The monograph resembles most closely the chapter on hydrogen by the late Dr. A. C. Greenwood in his excellent "Industrial Gases," but opportunity for much fuller treatment has been available in the present case. Ideas and information have been obtained from a perusal of other volumes, including the works of Ellis, "Hydrogenation of Oils," Teed, "The Chemistry and Manufacture of Hydrogen" and the British Admiralty "Hydrogen Manual," in two volumes, which deal intensively with two processes, the silicol and the steam-iron process. From the chemical literature, help in the form of articles and drawings has been obtained. These are acknowledged in the text. The electrolytic hydrogen industry, and especially the Electrolabs Co. and the International Oxygen Co., have placed material unstintingly at my disposal. It is a pleasure to record the assistance which many of my friends have given me in discussing points which appeared to be debatable. To the General Editor, Dr. John Johnston, and to Messrs. R. S. Tour and G. O. Carter, from all of whom suggestions have been received and accepted, my best thanks are due. My wife has lightened the clerical labours which inevitably accrue to such an undertaking. She has my generous appreciation.

Oct. 1, 1921.

## CONTENTS

	PAGE
CHAPTER I. INTRODUCTION . . . . .	15
Growth of the Industry. Uses of Hydrogen. Sources of Hydrogen Supply. Classification of Systems of Production. Choice of Process. Safety Precautions.	
CHAPTER II. HYDROGEN FROM STEAM AND IRON . . . .	25
Reactions of the Process. Historical. The Contact Mass. Typical Generator Units. Multi-retort Type. Single-unit Type. Operational Procedure. The Reduction Phase. The Steaming Period. Aeration. Thermal Balance of Process.	
CHAPTER III. HYDROGEN FROM WATER-GAS AND STEAM .	60
Theoretical. The Continuous Water-Gas Catalytic Process. Outline. Catalysts. Operational Details. Gas Composition Flow-sheets. Plant Details. Further Purification: Griesheim-Elektron Process. Outline. Literature Résumé. Mechanism of Reaction. Operational Details: Dieffenbach and Moldenhauer Process. Outline. Literature Résumé. Mechanism of Reaction.	
CHAPTER IV. HYDROGEN FROM WATER-GAS BY LIQUEFACTION . . . . .	90
Theoretical. The Linde-Frank-Caro Process. The Claude Process. Composition of Gas Fractions. Utilisation of Carbon Monoxide Fraction. Plant Details. General Remarks. Miscellaneous Physical Methods of Preparation.	
CHAPTER V. HYDROGEN BY ELECTROLYSIS . . . . .	102
Theoretical. Energy Factors. Mechanism. Early Forms of Apparatus. Modern Plants. I. O. C.-Unit	

Generator. Levin Cell. Burdett Cells. High Amperage Units. By-Product Electrolytic Hydrogen. Energy Factors in Alkali-Chlorine Cells. Types of Cells.

CHAPTER VI. HYDROGEN FROM WATER . . . . . 123

The Bergius Process. Description of Process. General Discussion. Field Processes. Metallic Sodium Processes. Hydrolith Process. Aluminium Amalgam Processes.

CHAPTER VII. HYDROGEN FROM AQUEOUS ALKALIS . . . . . 131

The Silicol Process. Outline. Literature Résumé. Experimental Data. Plant Details. Operational Details. Ferro-Silicon Specification. Gas Composition. The Sludge and Its Disposal. General Remarks on Efficiency and Economy: Aluminium-Sodium Hydroxide Process.

CHAPTER VIII. HYDROGEN FROM HYDROCARBONS . . . . . 147

Stability of Hydrocarbons. Processes of Thermal Decomposition. From Coal-Gas. From Natural Gas, Petroleum and Tar Oils. From Acetylene. Processes of Interaction with Steam.

CHAPTER IX. MISCELLANEOUS AND BY-PRODUCT HYDROGEN PROCESSES . . . . . 160

The Decomposition of Formates. Hydrogen from Dehydrogenation Processes. Hydrogen from Fermentation Processes. Hydrogenite Process. Hydrogen from Sulphides. Hydrogen from Acids.

CHAPTER X. THE PURIFICATION AND TESTING OF HYDROGEN . . . . . 171

Purity of Commercial Product. Removal of Sulphur Compounds. Removal of Carbon Dioxide. Removal of Carbon Monoxide. Removal of Methane. Removal of Phosphine and Arsine. Removal of Oxygen. Re-

## CONTENTS

11

moval of Water Vapour. Testing of Hydrogen. Physical Methods: Effusion Apparatus. Thermal Conductivity Processes. Gas Interferometer. Chemical Methods: Analysis for Carbon Monoxide. Analysis for Oxygen. Detection and Estimation of Phosphine, Arsine, Sulphuretted Hydrogen and Acetylene.

APPENDIX I . . . . .	201
INDEX TO AUTHORS . . . . .	204
INDEX TO SUBJECTS . . . . .	207





## ILLUSTRATIONS

NUMBER OF FIG.	SUBJECT	PAGE
1.	Equilibria in the System Fe - FeO - H <sub>2</sub> O - H <sub>2</sub> and Fe <sub>3</sub> O <sub>4</sub> - FeO - H <sub>2</sub> O - H <sub>2</sub> . . . . .	26
2.	Equilibria in the System Fe - FeO - CO - CO <sub>2</sub> and Fe <sub>3</sub> O <sub>4</sub> - FeO - CO - CO <sub>2</sub> . . . . .	27
3.	(a) Front Elevation—Lane Hydrogen Retort . . . . .	32
	(b) Sectional Plan—Lane Hydrogen Retort . . . . .	33
4.	Diagrammatic Representation of Lane Retort Valve System . . . . .	34
5.	Single Unit Hydrogen Retort—Grigg's Design . . . . .	39
6.	Flow Sheet for Water-Gas Catalytic Process . . . . .	76
7.	(a) Diagrammatic Outline of Converters for Water- Gas Catalysis . . . . .	78
	(b) Detail of Gas Flow through Interchangers . . . . .	78
8.	Vapour Pressure Curves of Liquid Nitrogen and Car- bon Monoxide . . . . .	92
9.	Diagrammatic Representation of Linde Liquefaction System . . . . .	94
10.	Diagrammatic Representation of Claude Liquefaction System . . . . .	95
11.	International Oxygen Co.'s Unit Electrolytic Gen- erator . . . . .	113

NUMBER OF FIG.		PAGE
12.	Electrolabs Levin Hydrogen-Oxygen Generator .	116
13.	Relation of Silicon Content to Hydrogen Yield in Silicol Process . . . . .	133
14.	Temperature—pressure—concentration diagram for alkali solutions . . . . .	135
15.	Silicol Process Results . . . . .	136
16.	Equilibria in the Systems Fe-FeO-H <sub>2</sub> O-H <sub>2</sub> , Fe <sub>3</sub> O <sub>4</sub> - FeO-H <sub>2</sub> O-H <sub>2</sub> , FeFeO-CO-CO <sub>2</sub> and Fe <sub>3</sub> O <sub>4</sub> -FeO-CO CO <sub>2</sub> . (Appendix I) . . . . .	201

# INDUSTRIAL HYDROGEN

## Chapter I.

### Introduction.

The production of hydrogen on a large scale is an industrial development of the last two decades. Prior to 1900 the utilisation of hydrogen was practically confined to the aeronautical field, for use in balloons, and to a few minor industrial uses such as for lead-burning, the working of platinum metals in the jewelry trade and the production of light, for the projection of pictures, by the burning of an oxy-hydrogen flame in contact with refractory oxides such as lime. In the main, these requirements were satisfied by electrolytic methods of production, hydrogen and oxygen generally being simultaneously produced. For the filling of balloons, in the field or in balloon stations, reliance was placed upon hydrogen produced by the action of sulphuric acid upon iron when a gas of greater lifting power than the more usual coal gas was required.

From 1900 onwards the demand for large scale hydrogen production has steadily increased, the gas now occupying a very important position in the field of pure gas technology. The advent of the dirigible balloon made the production of hydrogen imperative, since, by its use, the lifting and carrying capacity of the airship could be made adequate for the extra weight involved in the machinery, fuel and men employed to give direction to the vessel. From the early experimental ships of Santos-Dumont, through the laborious trials of Zeppelin, the lighter-than-air dirigible has evolved, especially during recent years, until the present time. The dirigible built in England for the United States Government and recently destroyed had a capacity of 2,700,000 cubic feet of hydrogen.

The development of hydrogen production in relation to dirig-

ible balloons has facilitated also the developments of stationary or kite balloons, as emphasized by the use which was made of such in recent wars for purposes of reconnaissance.

Paralleling this extraordinary growth in the field of aeronautics, a considerable development has occurred in the purely industrial use of the gas. The penetration of hydrogen in bulk into the industries has been brought about by the technical development of catalytic processes. The academic studies of Sabatier and his co-workers<sup>1</sup> in the catalytic hydrogenation of organic compounds by means of base-metal catalysts such as nickel, cobalt, copper and iron, led directly to the establishment of the industry of hydrogenation of oils. In this industry, the liquid glycerides of unsaturated acids, such as oleic acid, are converted by catalytic hydrogenation in presence of nickel or other catalyst into the solid glycerides of saturated acids, such as stearic acid. The hardened fats are made use of extensively in the production of edible products and also in the soap and candle industries. It is difficult to obtain accurate data in reference to the present consumption of hydrogen for such purposes. It may safely be stated, however, that several million cubic feet of hydrogen, of high purity, are daily consumed, in this country alone, for such purposes.

In solving the problem of fixation of atmospheric nitrogen the rôle of hydrogen production has assumed first importance. The successful development of ammonia synthesis in Germany and its technical operation since 1913 has entailed a tremendous development of hydrogen manufacture. The production of one ton (2,000 lbs.) of fixed nitrogen as ammonia involves the theoretical consumption of approximately 430 pounds, or more than 82,000 cubic feet, of hydrogen, measured at ordinary temperatures and atmospheric pressure. The hydrogen consumption of the Haber process plants in Germany, with a capacity in 1918 of 650 metric tons of ammonia per day,<sup>2</sup> will, therefore, readily be grasped. For purposes of ammonia synthesis a gas of high purity is essential. Recent developments outside of Germany, more especially in connection with the high pressure process of M. Georges Claude in France, of the modified Haber process of the General Chemical

<sup>1</sup> *La Catalyse en Chimie Organique*, 2nd Edition, Sabatier. Paris, 1920.

<sup>2</sup> *J. Ind. Eng. Chem.*, 1921, 13, 283.

Company in this country, and of the Nitrogen Corporation in England, suggest a very considerable multiplication of hydrogen requirements in the future for purposes of nitrogen fixation as ammonia.

The inevitable cheapening of the product, which results from the extended scale of manufacture, widens the field of possible technical applications. Already in use for catalytic hydrogenation in the fine chemical industry, hydrogen promises to find extended technical application in other catalytic operations. The production of pure hydrogen chloride by interaction with chlorine, the hydrogenation of benzene and of naphthalene for the production of hydrogenated products useful as fuels or solvents, the reduction of nitrobenzene in the vapor or liquid phases and the conversion of acetaldehyde to alcohol will serve as indications of potential hydrogen-consuming processes not too remote from practical industrial use.

Outside the catalytic field the utilisation of hydrogen has also increased. The development of the electric filament lamp has resulted in a large demand for hydrogen. The gas is employed in the reduction of the metallic oxides, in the working up of the metals into filaments and in the displacement of air from the lamp bulbs prior to evacuation. In this last operation, a nitrogen-hydrogen mixture is usually employed. As in the metallurgy of tungsten for the lamp industry, so with other rare elements largely in use for alloy purposes, the utilisation of hydrogen as reducing agent eliminates contamination of the product by carbon.

The use of the oxy-hydrogen flame for the fusion of the platinum metals is well known. In such operations the presence of carbon is avoided owing to the deleterious effect of carbides on the properties of the platinum metals. The development, however, of electric furnaces operating in absence of carbon or carbon-containing gaseous atmospheres, as for example the Ajax-Northrup electric induction furnace, will diminish the utilisation of hydrogen for such purposes and may also have an influence on the use of hydrogen in the non-platinum rare-metal industry.

Of minor importance in the question of hydrogen utilisation is the artificial gem industry. The fusion of refractory oxides such as alumina in presence of various color-yielding oxides,

as, for example, chromic oxide, gives synthetic gems such as rubies, sapphires and emeralds. These synthetic gems are, however, mainly use for personal adornment and the tonnage involved is small. Rubies find application, nevertheless, as small bearings for delicate mechanisms.

*The Sources of Hydrogen Supply.*—Hydrogen occurs in the free state in minimal quantities only in nature. Its concentration in the atmosphere certainly does not exceed 0.02 per cent. In certain natural gas supplies a higher concentration has been noted. For example, gas in the Ohio and Indiana fields may contain 0.5 per cent of hydrogen. Since the gas is occluded to a considerable extent by certain metals, for example, the platinum metals, nickel, iron and cobalt, it is occasionally present in large percentages in the gases evolved by such metals found in nature in the elementary condition. Thus, meteoric iron contains occluded gas which is mainly hydrogen. This is not surprising when it is remembered that hydrogen exists uncombined in large masses of the atmosphere of the sun, and also in other elements of the heavenly bodies. Violent volcanic eruptions yield gases containing free hydrogen, as was observed<sup>3</sup> in the analyses of gases from Kilauea, where the concentration was approximately 10 per cent.

In the combined state, on the other hand, hydrogen is extremely abundantly distributed throughout nature. Not only is it present to the extent of 11.1 per cent in all water but it is an essential constituent of organic matter, such as cellulose. It is the essential constituent of all acids and is present in important amounts in all hydrocarbons, from the simplest compounds present in natural gas to the most complex in heavy oils, waxes and coal.

Since, in respect to availability, water far transcends the hydrocarbon family, it is natural that the main source of industrial hydrogen is, in the last analysis, water. In certain cases, the production of the gas is attained with the utilisation of coal, coke or carbon in one or other form, as an auxiliary. The carbon, however, functions essentially as the reducing agent employed to liberate the element from the compound with oxygen. Physical methods of disruption of the compound may also be used. Thus,

<sup>3</sup> Day and Shepherd, *Bull. Geo. Soc. America*, 1913, 24.

electrolysis of aqueous solutions of acids or alkalis has an important place in hydrogen technology. From hydrocarbons, the hydrogen may be obtained by processes of thermal decomposition, in contrast to the case of water, where thermal decomposition is technically impossible owing to the high temperatures which would necessarily be involved. Indirect methods of obtaining hydrogen from hydrocarbons requiring chemical interaction either with steam or carbon dioxide have been suggested, but they have not attained to practical importance. As will be seen, also, hydrogen is obtained as a by-product and in small amounts from other classes of compounds such as formates, alcohols and acetone.

*Classification of the Systems of Hydrogen Production.*—The broadest system of classification will naturally be based on the source of the hydrogen, whether from water, hydrocarbon, or other source. The multiplicity of methods of obtaining the gas from water demands, however, a more elaborate system of subdivision of this section. This can conveniently be accomplished by relegating to distinct chapters the treatment of the methods of hydrogen production in which different forms of the raw material are concerned. Thus, water comes into use for hydrogen manufacture as steam and as water as well as in the form of the derived raw material, water gas. In the succeeding classification an attempt has been made at an orderly arrangement of the many processes to be considered, with this idea as the guiding principle. The order of raw materials has been chosen with the purpose of bringing forward first for consideration the methods of manufacture which are at present of major importance. Thus arranged, the groups and sub-groups come up for treatment as follows:

A. *Hydrogen from Water:*

I. From Steam

- |   |   |                             |
|---|---|-----------------------------|
| (1) By alternate<br>interaction of<br>iron with<br>steam and of<br>iron oxide<br>with water gas | } | (a) Multi-retort processes  |
|   |   | (b) Single retort processes |

- II. From Steam and Water Gas
- |   |   |   |
|---|---|---|
| (1) By continuous interaction in presence of a catalyst | } | (a) The Continuous or Badi-<br>sche Process<br>(b) Processes with displace-<br>ment of equilibrium.<br>Griesheim-Elektron Co.'s<br>process<br>(c) Single stage or Dieffen-<br>bach and Moldenhauer<br>process |
|---|---|---|

III. From Water Gas

- |   |   |  |
|---|---|--|
| (1) By processes of liquefaction, involving carbon monoxide removal | } | (a) Linde-Frank-Caro process<br>(b) Claude process |
|---|---|--|

IV. From Water

- (1) By electrolysis. Various plant types
- (2) Employing carbon or iron and water under pressure. Bergius process
- (3) Employing alkali metals
- (4) Employing hydrides
- (5) Employing metallic alloys

V. From Aqueous Alkalis and Hydroxides

- |                                |   |  |
|--------------------------------|---|--|
| (1) Employing metals or alloys | } | (a) The Ferro-Silicon process<br>(b) Aluminium process |
|--------------------------------|---|--|

*B. Hydrogen from Hydrocarbons:*

- (1) By thermal decomposition
- (2) By interaction with steam
- (3) By interaction with carbon dioxide



C. *Hydrogen from Miscellaneous Sources including By-product Hydrogen:*

- (1) By decomposition of formates
- (2) By dehydrogenation of alcohol
- (3) By fermentation processes to yield acetone
- (4) The Hydrogenite process
- (5) Hydrogen from sulphides
- (6) Hydrogen from acids.

The processes included in A I, A II, A III and A IV (1) form the subject matter of Chapters II to V inclusive. Chapter VI deals with the chemical methods of obtaining hydrogen from water. The succeeding chapter is devoted to hydrogen from aqueous alkalis and hydroxides. Chapter VIII sketches out the problems listed under B, hydrocarbons forming the raw material. Chapter IX collects the miscellaneous methods of manufacture and discusses by-product hydrogen. A final chapter is added on the purification and testing of hydrogen.

*Choice of Processes.*—In the succeeding chapters it will emerge that a variety of processes have attained to a standardised technical development. Enquiry will therefore naturally be forthcoming as to preferred processes among so many. The answer to such enquiry can only be intelligently given with reference to the particular usage to which the product is to be put and also with reference to the locality in which the gas is to be produced. For operations involving small consumptions of gas, say a few hundred feet of gas per hour, it is probable that an electrolytic unit would best meet the case. The relatively high initial outlay and cost of power required would be offset by the minimum attention needed by the plant. For large consumption the cost of plant and cost of production become paramount. For example, in the synthesis of ammonia, where the hydrogen represents as much as 75 per cent of the gas mixture employed and about 17.5 per cent of the weight of ammonia produced, these considerations outweigh all others and recourse is had to that process, the catalytic process (Chapter III), in which the hydrogen can be most cheaply produced. The presence of nitrogen as an almost inevitable impurity in such gas, however, limits its applicability in other directions than that of ammonia synthesis, in which process, of course, the nitrogen is a needed constituent

of the gas mixture. Hence we find that, in the field of aeronautics and in the hydrogenation of oils, more expensive but purer grades of hydrogen are in use, for example, steam-iron process and electrolytic hydrogen in the majority of cases.

Since, in the electrolytic process both hydrogen and oxygen are produced, the localisation of the plant is an important factor in the determination of the process to be preferred. In several cases in this country the substitution of electrolytic hydrogen for other processes has resulted in considerable economic benefit owing to the revenues accruing from the disposal of the by-product oxygen. Similar returns from oxygen disposal are possible in the case of the Linde process of hydrogen production from water gas (Chapter IV) in which, by rectification of the liquid air used in the liquefaction process, oxygen and nitrogen may be received as by-products. In the early stages of development of the synthetic ammonia process at Oppau, Germany, the nitrogen required was so obtained, the saving thus accruing being credited to the hydrogen process.

Attention should be directed to the desirability, in certain circumstances, of combining two types of unit. For steady production the unit chosen should provide hydrogen of the necessary grade at a minimum cost inclusive of investment cost. For emergency purposes, as for example, during overhaul periods or when an excess of gas is required for a special occasion, the provision of a stand-by unit, low in investment cost, is desirable. A unit of the silicol process type (Chapter VII) fulfills such a purpose and should be of special importance in aeronautic work where great demands often occur, as in the first inflation of a ship, or after a gas bag has been ripped in a big ship, or when the entire gas contents must be changed in a smaller vessel.

*Safety Precautions.*—Especial care is necessary in the operation of hydrogen production owing to the dangers of fire and explosion associated with the gas and the gaseous materials with the aid of which it may be produced. The ignition point of hydrogen gas is low, circa 580-590° C., dependent, however, to some extent on the concentration of the gas and the oxygen-nitrogen ratios.<sup>4</sup> Carbon monoxide, which is the other principal combus-

<sup>4</sup> K. G. Falk, *J. Amer. Chem. Soc.*, 1907, 29, 1536. Dixon and Coward, *J. Chem. Soc.*, 1909, 95, 514.

tible constituent in the water-gas from which hydrogen is frequently obtained, has an ignition-point, according to the same authors, varying between 637 and 658° C. in oxygen, and between 644° and 658° C. in air.

Combustion of inflammable gases mixed with air or oxygen will only take place within fairly well defined limits of concentration. To ensure propagation of flame, it is necessary (1) that the initial source of heat should be of a volume, intensity and duration sufficient to raise the layer of gases in its immediate vicinity to a temperature higher than, or as high as, the ignition temperature of the mixture; and (2) that the heat contained in the products of combustion of this first layer should be sufficient to raise the adjacent layer to its ignition temperature.<sup>5</sup> There are two limits of concentration, the one is the lower limit of inflammation corresponding to the smallest concentration of combustible gas which, with air or oxygen will enable self-propagation to take place. The other or upper limit corresponds to the maximum concentration which will so act. The limits vary somewhat with the shape and size of the containing vessel. They are extended in wider vessels. Increased pressure also tends to widen the limits, as does, also, increase of temperature.<sup>6</sup> This may, however, be specific to certain gases, since Terres and Plenz<sup>7</sup> state that increase of pressure narrows the limits in the case of carbon monoxide-air and hydrogen-air mixtures. The data for the several gases concerned, as compiled from recent data, are given in the following tables, referring to explosive limits at atmospheric pressure with gas-air mixtures:

<i>Gas</i>	<i>Lower Limit</i>	<i>Upper Limit</i>
Hydrogen <sup>8</sup> .....	4.1	74.2
Carbon monoxide <sup>8</sup> ..	12.5	74.2
Methane <sup>9</sup> .....	5.3	15.4
Water-gas <sup>9</sup> .....	12.4	66.8

<sup>5</sup> Burgess and Wheeler, *J. Chem. Soc.*, 1911, 99, 2,013.

<sup>6</sup> See Burrell and Gauger, Bur. of Mines, Tech. Paper, No. 150. Burrell and Robertson, Bur. of Mines, Tech. Paper, No. 121.

<sup>7</sup> J. Gasbeleucht., 1914, 57, 990, 1,001, 1,016.

<sup>8</sup> Coward, *J. Chem. Soc.*, 1914, 105, 1,859. Coward, Carpenter and Payman, *Ibid.* 1919, 115, 27.

<sup>9</sup> Bunte, 1901.

Since the sensitivity of hydrogen to explosion is so great, the greatest care is essential in exposing hydrogen streams to flames. Certainty is indispensable in this connection. As a consequence, adequate "purging" of a system, with hydrogen known to be safe as regards oxygen content, should always be carried through before flames are brought into action. Absence of oxygen is to be strongly recommended when inflammable gases are undergoing compression, since the momentary rise of temperature of the gas during the compression stroke may be sufficient to bring about explosion. Furthermore, in the release of compressed hydrogen to closed systems, as, for example, to gauges, the operation should always be performed gradually, since sudden opening of the valve may cause adiabatic compression of the first gas and of air or oxygen in the gauge, with consequent rise in temperature.

## Chapter II.

### Hydrogen From Steam.

The great bulk of hydrogen consumed in the hydrogenation of oils is produced by means of the steam-iron process. The hydrogen is generated by the interaction of steam with iron at temperatures ranging according to choice from 550° C. to 800° C. The reaction, which may be formulated by means of the equation,

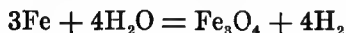

is in reality a reversible process. Low temperatures favor hydrogen production, high temperatures the reduction of iron oxide. Furthermore, the total reaction may be regarded as occurring in two stages,

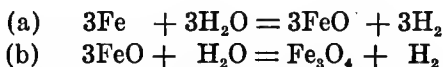

and in each stage definite equilibrium relationships hold. The data of Chaudron<sup>1</sup> plotted in the accompanying diagram, Fig. I, show the respective ratios of  $p_{\text{H}_2\text{O}}/p_{\text{H}_2}$  for various temperatures when the solid phases present are Fe-FeO and FeO-Fe<sub>3</sub>O<sub>4</sub> respectively. It will be seen that, in the region of operating temperatures chosen, both oxidation and reduction may take place to a marked degree according to the nature of the contact material and the gas passing over it. Thus, if the contact mass be iron or ferrous oxide, treatment with steam will result in hydrogen production. If the mass be magnetic oxide of iron, Fe<sub>3</sub>O<sub>4</sub>, and the gas passing be hydrogen, marked reduction will occur. The steam-iron process is operated with such an alternation of reactions. Hydrogen is produced by passage of the steam over the reduced contact mass, the magnetic oxide of iron thereby produced being reduced in a succeeding operation to the metallic

<sup>1</sup> Comptes rend., 1914, 159, 237. See, however, Schreiner and Grimnes, *Zeit. anorg. Chem.*, 1920, 110, 311, who obtain somewhat different values, which, however, are no more satisfactory when correlated with the equilibrium data using carbon monoxide nor with the equilibrium in the water-gas reaction. See also Appendix I.

or lower state of oxidation by means of a suitable reducing gas. For technical purposes, the reducing gas most generally employed is water-gas, being the gas with the maximum content of reducing agents consistent with the economy of the process.

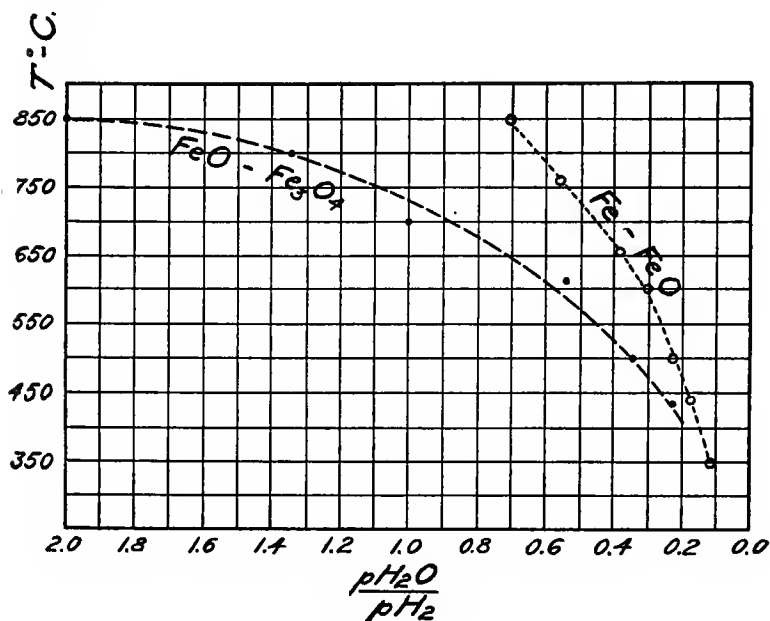
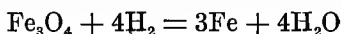
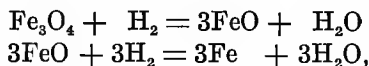

FIG. 1. Fe-FeO and FeO-Fe<sub>3</sub>O<sub>4</sub> Equilibria.

Hence, the reduction of the contact mass involves two reactions, the first being the reverse of that occurring in the steaming phase



which really occurs in two stages



the second being the corresponding reaction with carbon monoxide—a reaction which also may be formulated in two stages

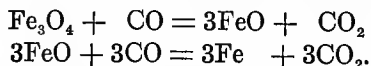

As with the corresponding reaction involving steam and hydrogen, these reactions are also reversible and the equilibrium ratios

of the carbon dioxide and carbon monoxide at various temperatures are set forth graphically in the accompanying diagram, Fig. II, compiled from the best available data on the equilibria.<sup>2</sup> Other reducing gases, such as producer gas, may be employed, as will be indicated later. In principle, however, the process and the reactions occurring are not affected by such change.

*Historical.*—The essential reaction, the interaction of steam and iron is a very old one and was early embodied in patent applications. Joseph Jacob (B. P. 593/1861) claimed the commercial production of hydrogen by the action of steam on iron bor-

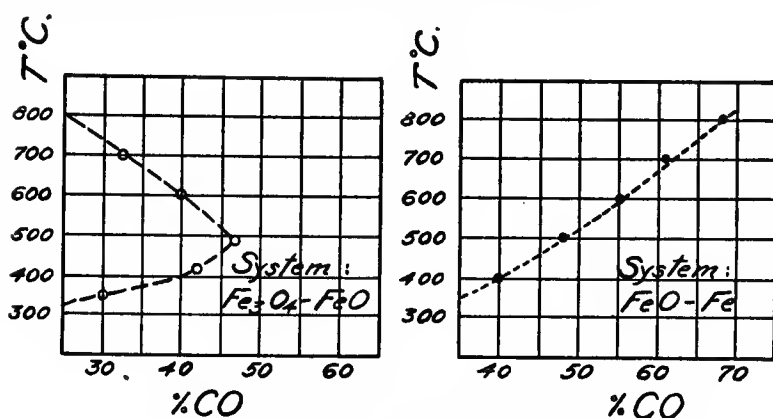

FIG. II. Fe-FeO and FeO-Fe<sub>2</sub>O<sub>3</sub> Equilibria.

ings or filings or on iron crushed, ground or pulverised. A portion of the hydrogen produced was to be burned on the outside of the retorts in order to maintain the reaction temperature. The iron after interaction with the steam was to be discharged from the retorts and utilised for other purposes. Similar early patent claims are due to Isham Baggs (B. P. 2,719/1865 and 1,471/1873). An unsuccessful attempt at commercial production by the steam-iron process was made by Giffard in 1878. The iron rapidly became inactive due to sintering of the material and to chemical reaction with impurities in the reducing gases used.

The Lewes patents, B. P. 20,752/1890 and 4,134/1891, represent the beginnings of a serious attempt to solve the commercial

<sup>2</sup> Schenck, *Ber.* 1905, 38, 2,132; 1907, 40, 1,708. van Royen, *Diss. Bonn.* 1911. Levin and Küster. *Nernst Festschrift.* Falcke. *Z. Elektrochem.* 1916, 22, 121.

production of pure hydrogen. In the earlier claim, the contact mass, iron turnings or a suitably moulded oxide, was to be contained in a retort embedded in the fuel bed of a gas producer making an air producer gas. Thereby, the mass was to be maintained at a sufficient temperature and the producer gas was to be used for the reducing phase. In the later claim, various forms of contact mass are mentioned, including iron obtained from its salts deposited on asbestos or pumice or obtained by admixture of moist hydroxide of iron with a suitable support material. A semi-water-gas containing both carbon monoxide and hydrogen in addition to nitrogen is also cited as preferable to carbon monoxide and nitrogen alone.

Development of the engineering details associated with the proposals of Lewes relative to hydrogen production was energetically undertaken in England by Lane. The resulting improvements are embodied in several patents to Lane and others.<sup>3</sup> They resulted in a departure from the single shaft of material as proposed by Lewes and the substitution of a multi-retort plant which has been largely employed in the Lane form or with modifications introduced by other plant erectors. Details of such plant will be considered later.

The single retort unit, on the other hand, has been intensively studied and developed by German investigators. The principal plant based on this system is the Messerschmitt plant of which several modifications exist.<sup>4</sup> Modifications of the single retort unit are also due to the Badische Anilin u. Soda Fabrik and others.

*The Contact Mass.*—Since the reaction with steam occurs mainly on the surface of the iron and penetrates little, if any, into the interior of the solid mass, it is desirable that the iron employed should be in such a form as to expose the maximum amount of surface consistent with the other properties requisite in the chosen material. A porous reactive form of iron is therefore chosen. On the other hand, the contact mass should be physically robust, as the alternation, the contact mass should be physically robust, as the alternation of oxidation and reduction promotes disintegration, leading to accumulation of finer ma-

<sup>3</sup> Hills and Lane B. P. 10,356/1903. Lane and Montoux Fr. P. 386,991/1908. Lane, B. P. 17,591/1909; 11,878/1910. U. S. P. 1,028,366/1912. 1,040,218/1912; 1,078,686/1913.

<sup>4</sup> D. R. P. 291,902/1914; U. S. P. 1,109,447/1914; U. S. P. 1,152,196/1915; U. S. P. 1,225,262/1917; U. S. P. 1,225,263/1917; U. S. P. 1,225,264/1917.



terial and the development of a back-pressure in the retort-system. Difficulties arise also in choice of contact material owing to the tendency towards local overheating within the retorts, which results in a sintering of the mass, loss of activity and consequent diminution of hydrogen yield.

Material of suitable quality is generally obtained from a carbonaceous or oxide ore of iron which, after calcination and reduction, is in the requisite porous condition. The material most commonly employed is a calcined spathic iron ore. Originally a carbonate of iron, the ore suffers loss of carbon dioxide on heating and yields an oxide of the requisite quality. A certain amount of fusion occurs in the calcination process. The material has somewhat the porous appearance of coke but is considerably denser, very robust and resistant to disintegration. Claim is made for such a contact mass in the patent of Dieffenbach and Moldenhauer.<sup>5</sup> It was, however, employed in technical practice some years previous to the date of this application. Before 1917, American producers of hydrogen by the steam-iron process imported their contact material, mainly from England. During the war it was necessary to make use of home supplies of iron ores but these were found to be much inferior to the imported calcined spathic ore. In addition to the English product a contact mass obtained by calcination of a Spanish carbonaceous iron ore has been used with success.

The nature of one method of preparation is disclosed in a patent to Bates and Bates (B. P. 134,155/1919) according to which the material is obtained in suitable form for use by stacking the spathic ore in heaps with a covering of small fuel, allowing the heap to burn slowly for several days. The hot heap is then quenched with water and the ore when cold is washed with water to free it from impurities. The British Oxygen Co., Bray and Balfour, soak the ore for one-half hour in commercial hydrochloric acid, after which it is washed thoroughly with water and is dried for use. A more porous and active material is thereby produced (B. P. 122,474/1918), it is claimed.

The Dellwik-Fleischer Co. claim<sup>6</sup> the use of burnt pyrites as contact material. When roasted to expel all the sulphur the material is not generally very reactive, and, if the calcination is

<sup>5</sup> D. R. P. 232, 347/1910.

<sup>6</sup> B. P. 7,849/1909.

stopped short of complete removal of sulphur, the hydrogen initially produced contains a high concentration of sulphur compounds. With use, however, the material improves.

A high grade contact mass is obtainable from Swedish iron ore, an oxide ore of exceptional purity, low in sulphur and phosphorus. The oxide may be utilised directly for charging into the retorts, where, after reduction, it possesses the requisite porous condition and strength. An improved form of this material is obtained by admixture of the broken ore with limestone and carbon in suitable form. The material is then calcined at relatively low temperatures, reduction of the oxide being effected by the carbon monoxide produced in the combustion process. In this way a spongy form of iron of high reactivity and considerable strength may be obtained. It is, however, relatively costly. Such material also forms a suitable basis for contact material in the water gas catalytic process discussed elsewhere.

In addition to reduced iron ores, other contact agents have been employed. Alloys of iron, especially with manganese, chromium, tungsten and titanium are claimed in the patent of Dieffenbach and Moldenhauer.<sup>7</sup> Ferro-manganese shows a higher rate of reactivity with steam than does a compact iron under similar conditions. During the war, patents employing such alloys were utilised by English hydrogen producers under license, in place of iron ore contact masses. Such alloys show less tendency to sinter with local overheating and thus lose their activity less rapidly. They also deteriorate less with use. According to Messerschmitt,<sup>8</sup> manganese additions are of especial value in preventing carbon deposition in the contact mass, a circumstance tending, as will be shown, towards a purer hydrogen product. Such contact agents, however, obviously entail a high outlay for contact material.

Impregnation of spongy Swedish iron with an alkali hydrate or carbonate is a modification of the contact mass employed by Thorsell and Lundén in Sweden to increase the active life of the contact mass.<sup>9</sup> Iron thus treated is probably much more reactive towards steam than the untreated material. It should therefore be possible to operate at lower reaction temperatures

<sup>7</sup> B. P. 12,051/1912.

<sup>8</sup> U. S. P. 1,109,448/1914.

<sup>9</sup> See B. P. 119,591/1918.

and thus diminish loss of activity due to sintering. Examination of active material and the same material after use and consequent loss of activity, shows, in the former case, an open porous structure and, in the latter, a smoother surface due both to loss by abrasion and to local fusion of the surface. Lower reaction temperatures therefore favour increased duration of active life of the contact mass. Similar claims to those of Lundén and Thorsell have been made by Maxted,<sup>10</sup> who recommends addition of alkalis, alkaline earths and copper salts.

The Badische Anilin u. Soda Fabrik<sup>11</sup> patented the use of oxide of iron prepared synthetically by fusion of iron in oxygen. Incorporation of refractory oxides such as magnesia or zirconia in such synthetically prepared materials was also suggested. There is no evidence that such synthetic contact masses have come into general use and, it is evident, they must have a high initial cost compared with oxides of iron produced from natural iron ores.

*Typical Generator Units*—(a) Multi-retort type.—The pioneer hydrogen generator of the multi-retort type is that due to Lane and examples of this system of operation are to be found in America, England, France and Russia in the factories which were among the earliest to concern themselves with the hydrogenation of oils.

A Lane generator unit contains three sets of twelve retorts each filled with the material used as contact mass. The retorts are arranged vertically in a rectangular firebrick combustion chamber in groups as indicated in the diagram (Fig. III). They average 10 to 12 feet in length with an internal diameter of 9 inches. They are closed at the two ends by means of plates bolted to flanges on the retort ends, asbestos joints being used to make the fittings gas-tight. With suitable valve and pipe connections, diagrammatically shown in Fig. IV, the sets may be supplied with water-gas or steam, the direction of these gas streams being opposite to one another through the retorts. Lane found<sup>12</sup> that the reducing stage was considerably less rapid than the steaming phase. Consequently, the generator is so arranged that two of the three sets of 12 retorts are being treated with

<sup>10</sup> B. P. 125,410/1916.

<sup>11</sup> B. P. 6,683/1912.

<sup>12</sup> B. P. 17,591/1909.

water-gas while the third set is being steamed. With a steaming phase of 10 minutes' duration the time occupied in the reduction is therefore 20 minutes and a cycle is established whereby hydrogen is generated from the three sets in succession once every half hour. With this arrangement as to time and with a unit of

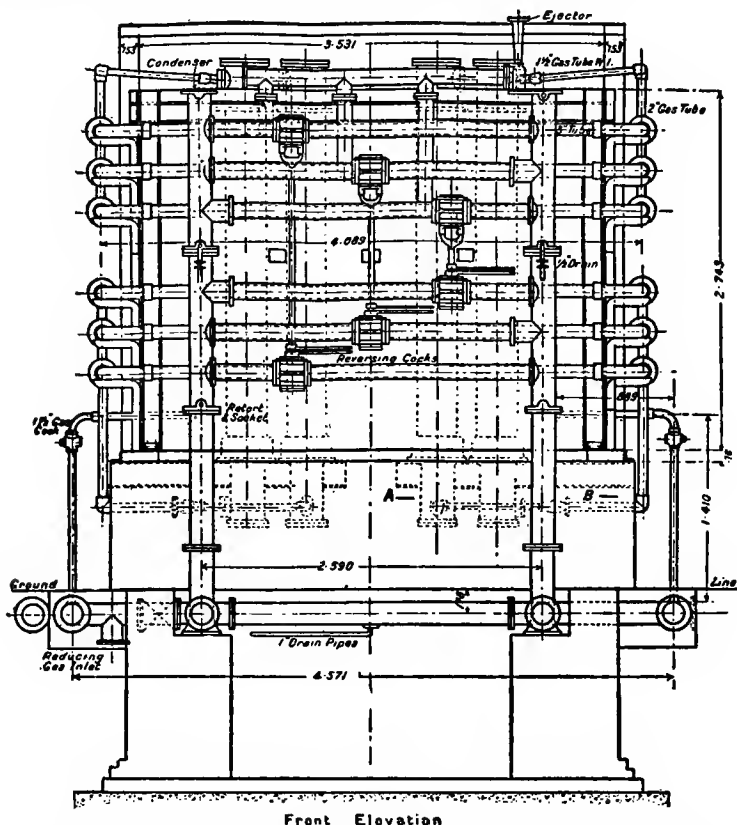

FIG. III. (a) Front Elevation of Lane Generator Unit. (The Engineer.)

the size stated, an hourly production of 3,500 cubic feet of hydrogen is possible. After the reducing period, the retorts are full of partially spent water-gas. To avoid introduction of this gas into the hydrogen obtained when the steam is turned into the retort system Lane introduced a brief period of "scavenging" or "purging" between the reducing phase and the hydrogen make. For 15 to 30 seconds after the steam is admitted, the hydrogen

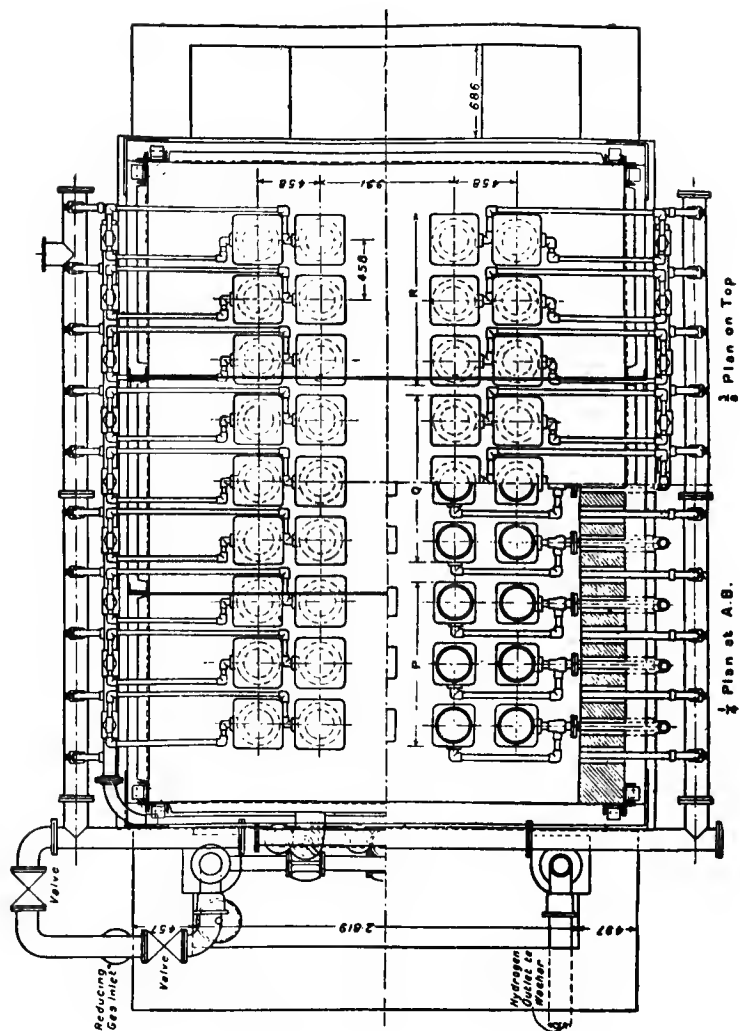

FIG. III. (b) Plan of Lane Generator Unit. (The Engineer.)

produced is allowed to follow the spent water-gas until the retort system is sufficiently freed from carbon-containing gases. Then, by a change-over valve, it is diverted to the hydrogen purification system and holder.

To maintain the reaction temperature, the spent water-gas, which still contains, after leaving the retort system, a marked proportion of combustible gases, is cooled in a scrubber condenser to free it from steam and is then returned to the generator to be

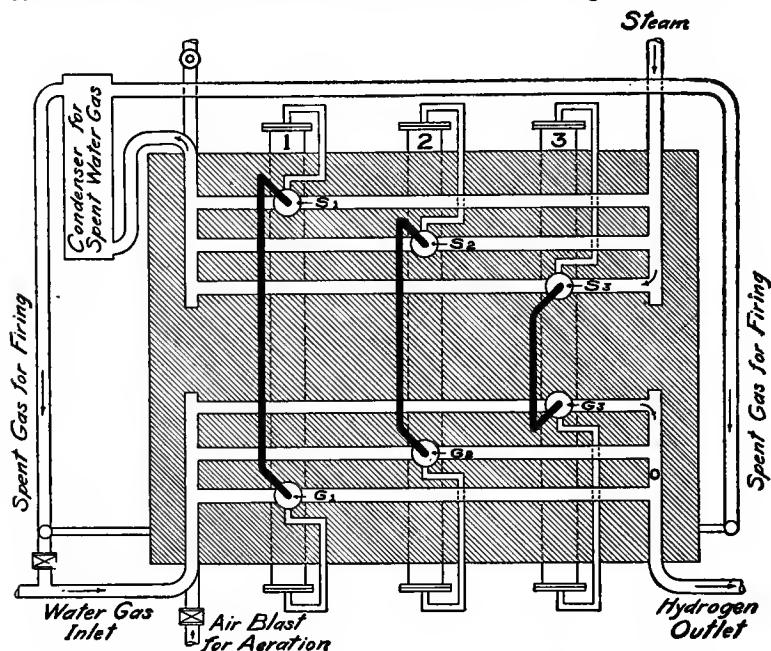

FIG. IV. Diagrammatic Representation of Valve System

burned on the outsides of the retorts. The gas is led in pipes through holes in the lower section of the combustion chamber and burned around the base of the outside retorts of the setting. A simple length of iron pipe serves as burner since the gas requires no admixture with air prior to combustion.

Several modifications of the Lane plant have been made in later forms of the multi-retort generator. Thus, a number of plants recently erected provide a producer along with the retort setting and placed about six feet below the same. The producer delivers to the outside of the retorts a producer gas through

flues arranged between the two parallel sets of retorts. Secondary air, preheated by passage through the combustion chamber, is utilised for combustion of the producer gas. The products of combustion may or may not pass through heat recovery units. With such a method of heating, it is claimed, a more even temperature can be obtained than is possible with generators burning spent water-gas. One such unit showed a working temperature of 625° C. with a normal variation of  $\pm 5^\circ$  C. On the other hand, the available heat units of the spent water-gas, which, as shown in the Lane practice are adequate for temperature maintenance, will not be utilised unless special uses are found for such. In one plant the spent water-gas is utilised in raising steam for the steaming phase. According to Ballingall<sup>18</sup> the spent water-gas leaving the retorts may be raised in temperature in a heat interchanger, and led through the reaction zone of a gas producer. Here the carbon dioxide and steam are partially reduced to combustible gases, which are then burned with an insufficient amount of air around the retorts. A further addition of air then permits the completion of the combustion process and the hot gases are used in the heat interchanger to preheat the gases leaving the retort system. It is obvious that, in this mode of procedure, the fuel consumption is greater than in the simple Lane procedure although possibly not so great as in the case where heating is effected by means of producer gas alone. In this latter case, a coke consumption of 30 cwt. per 100,000 cubic feet of hydrogen produced per day, in addition to that consumed in making the reducing gas, is representative of average practice.

A modification of the Lane system applicable where a large hydrogen output is required, consists in employing three generator units each of 36 retorts for the reduction-oxidation cycle instead of dividing each unit into three sets of twelve retorts. In this case one whole unit is producing hydrogen while the other two units are being reduced. It is evident that, with such an arrangement, an economy of valves and piping is obtained, since, to each unit one set of valves in place of the three shown in the diagram (Fig. IIIa) are sufficient. In another modification, in use in this country, the setting contains but 12 retorts which are larger in dimensions than those in the 36 retort units.

As will be discussed in detail later, carbon and some sulphur

<sup>18</sup> B. P. 106,067/1917.

compounds generally accumulate in the contact mass. These bodies, which give rise to impurities in the hydrogen produced, are periodically removed by blowing or pulling air through the retorts. The accumulations are thus oxidised to carbon monoxide, carbon dioxide and sulphur dioxide. The "burning-off" process is accomplished either by compressed air from a blower or by means of a steam-ejector which pulls the air through the retort system. The "burning-off" period follows upon a steaming phase and is followed by the usual reduction period with water-gas.

The life of the retort constitutes a factor of great importance in the economy of the multi-retort process. The temperature maintained and the attention devoted to the air-gas ratio used in the temperature maintenance largely determine the length of life of a retort. The flame employed in the heating process should be as nearly theoretical for complete combustion as is practicable. Excessive oxidation conditions, especially, cause the retorts to scale badly. The interior of the retorts do not suffer materially in the cycle of operations. With a working temperature of about 650° C. an average retort should have a life of 12 months. The economy of alloys and alloy-steels capable of withstanding high temperatures deserves extended study by the hydrogen manufacturer.

The durability of the ore is a further factor of economic importance concerning which the most divergent views are held. Average practice gives the ore a life of about 6 months, so that a retort of average life will be charged and discharged twice. The usual method of procedure on discharging a hydrogen bench is to discard entirely those retorts in poor condition, making up the new furnace with a series of retorts either all new or all of approximately equal state of repair. After discharging, the ore is graded, the fine material being rejected and that of suitable size being again used with a further supply of new ore. On the other hand, in one plant known to the writer, a much more frequent renewal of the ore is usual than in the average practice. A renewal, on an average once every two months is effected in this case, with the object of maintaining a high reactivity of the material and consequent high output of hydrogen from a single setting. The object of this will be enlarged upon in the subsequent discussion on the ratio of water-gas consumption to hydro-



gen produced. It is held in this case that the extra yield thus obtained more than balances the extra cost entailed in charging and discharging ore. That this item is serious is evidenced by the devices now being introduced to facilitate the operation. Dempster<sup>14</sup> proposes to provide the retort with a perforated platform mounted on a vertical shaft and capable of being raised or lowered from top to bottom of the retort in the filling process. Projections on the internal wall of the retort are provided, to guide the platform, which may be revolved as well as moved vertically. A more recent patent claim<sup>15</sup> by W. J. and W. R. Bates, calls for the use of perforated or open-work cages of varying mesh suitable for different grades of ore. The coarsest material is to be placed in the cages at the bottom, the finest at the top of the retorts. Expanded metal is used for the bottom and body of the cage, and removable lids are provided to close the top during transport. A flange or projection to fit the top of the cage next beneath it in the retort is provided for each. Eyes are fitted for engagement with a lifting and lowering appliance for use during charging or discharging.

(b) The single retort type.—The single retort represents an attempt to avoid some of the difficulties inherent in the multi-retort system of hydrogen generation by the steam-iron process. Thus, since external heating involves a comparatively small narrow retort, the unit retort system employs internal heating and a large contact bed. A more even temperature distribution is also sought thereby. The choice of such a system is further determined by considerations of wear and tear in the multi-retort system, and also of difficulties and expense involved in the charging and discharging of the ore.

This type of generator has been developed principally in Germany, but a number of such plants have been recently erected in this country and in England.

The evolution of the single-retort unit can be traced through the patent specifications of Messerschmitt already cited. The earlier designs called for cylindrical beds of material. Uneven temperature distribution apparently resulted, for various devices were patented to avoid fusion of the contact mass. The mass was split up into sections by plates, grids or screens of iron,

<sup>14</sup> B. P. 104,115/1916.

<sup>15</sup> B. P. 137,674/1919.

or by bars of iron placed vertically. The latest modifications of Messerschmitt<sup>16</sup> plant substitute for a cylindrical bed of material a narrow annular column which may be heated by a central combustion chamber of checker brick work, or may be placed between two checker brick columns. In this later type (compare with Figure V following) water-gas is mixed with air insufficient for complete combustion and introduced into the central combustion chamber. The mixture there reacts and the hot reducing gas thus produced is then passed downwards through the annulus of ore to bring about reduction of the oxide of iron. It is then mixed with a further quantity of air and completely burnt in the outer checker brick chamber. It passes thence to the flues. After a suitable period of scavenging, steam is admitted at the top of the outer checker brick chamber which is now the hottest part of the unit, and is superheated whilst passing through the chamber. It then passes through the reduced ore from the bottom upwards. The steam-hydrogen mixture is drawn off at the top of the contact mass and is led to the purification system. With such an arrangement of contact bed and checker-brick combustion chambers it is possible to reverse the course of combustion and the directions of gas and steam flow. In this way a more even temperature distribution throughout the bed is secured than is possible with a single combustion chamber centrally placed.

For such units, a cycle similar to that adopted in the multi-retort system also holds. The reducing phase normally occupies 20 minutes and the steaming phase 10 minutes. The same considerations hold with regard to modifications of procedure in the two operations as in the multi-retort type and these will be discussed in detail in later sections.

It is apparent that, with such type of plant, renewal of contact material is more easily effected than in the case of a multi-retort unit. It is doubtful, however, whether the same high purity of gas can be secured with this type, since scavenging of the checker brick chambers in addition to the ore annulus is necessary.

The patent to Griggs<sup>17</sup> embodies the latest features of the single retort unit as evolved, during the war, from large scale

<sup>16</sup> U. S. P. 1,225,262, 1,225,263 or 1,225,264/1917.

<sup>17</sup> B. P. 142,882/1920.

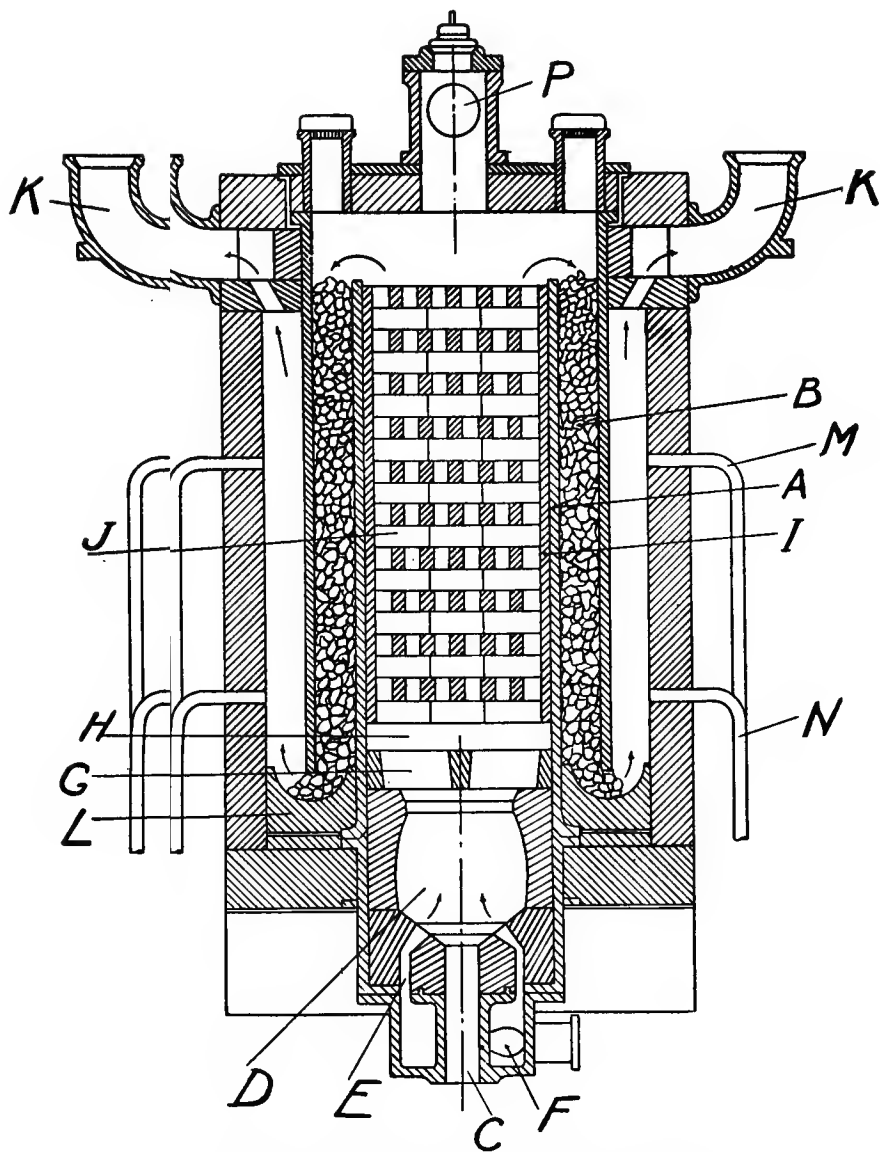

FIG. V. Single Retort Unit for Steam-Iron Process.

operation of the process. According to the patent claims, the invention consists in providing a combustion chamber D (Fig. V) at the lower end of the inner heating space and below the bottom level of the ore in the ore chamber, the streams of air and reducing gas being led in at the bottom of the combustion chamber by relatively inclined passages E to cause intermingling immediately the gases enter the chamber. Complete combustion of the gases is thus caused to take place within the combustion chamber and below the level of the ore chamber, the inner heating checker-brick work chamber J being used for heat storage only. In order to facilitate still further the rapid mixing of the air and gas the air supply may be given a circular motion by arranging a tangential connection to the air box as at F in the accompanying diagram. The combustion chamber D may be constructed of such shape that it will assist in promoting mixture and, thereby, combustion of the gases, by increasing the thickness of the fire-brick walls towards the upper end of the chamber. The inner side of the liner A is protected by a firebrick lining I which causes the life of the inner metal liner to be greatly lengthened.

Scavenging is carried out by steam introduced through the reducing gas inlet C and passing successively through the inner checker-work J, the ore annulus B and the outer air-chamber to the waste-gas vents K. The steam for the hydrogen make is then introduced at K the vents being now closed and the hydrogen withdrawn through P.

The excess of combustible gas employed in the reducing phase may be burnt by auxiliary air supplies introduced into the outer chamber by the pipes M and N, generating additional heat in the outer annulus and thereby conserving the temperature of the iron contact mass.

With such a method of procedure it is claimed that the annulus of ore may be maintained readily at an even and not excessive reaction temperature, whereas, in the older forms, the variation in temperature along the length of the annulus was very marked. Griggs<sup>18</sup> states that with such an apparatus, hydrogen production can be carried out more satisfactorily than with any of the retort type processes.

<sup>18</sup> *Hydrogen Manual*, Part II.

The patent to Abbott,<sup>19</sup> assigned to the Improved Equipment Co. of New York, shows how, by a series of 4 single retort units and a special heating chamber, a continuous production of hydrogen by this system may be achieved.

The concentric ore and combustion chambers of the Messerschmitt plant are all separated in the patent of Bosch,<sup>20</sup> which represent the modification of the steam-iron process as advertised by the Berlin Anhaltische Maschinenbau Aktien Gesellschaft. In this patent three separate shafts are used, two checker brick preheaters and one ore shaft. The reducing gas is first passed through the ore and then completely oxidised with the addition of air in one of the combustion chambers. The other combustion chamber is then used to superheat the steam prior to passage through the reduced ore. In the subsequent cycle, the rôle of the two preheaters is reversed and so, upon completion of the two phases of reduction and steaming, the state of the system is the same as at the beginning of such phases.

Various other modifications of the single retort unit are to be noted. One is due to Schaefer,<sup>21</sup> who insists that to avoid overheating in the contact mass by burning gases directly in the ore more than the theoretical amount of air must be mixed with the water-gas. Spitzer<sup>22</sup> uses a mixture of producer gas and excess of air to raise the temperature of the contact mass, uses water-gas for reducing the oxide of iron and burns the spent water-gas to superheat the steam. Moses<sup>23</sup> has an apparatus which is a combination in one unit of several features of the Messerschmitt and Bosch types of plant, and aims at evenness of temperature distribution by complete freedom of action with regard to course of gas combustion and alternation of direction of gas flow.

*Operational Procedure.*—In starting a plant from cold the procedure will vary with the type of generator employed. A multi-retort unit with built-in producer will be brought to reaction temperature by starting the producer and burning the gas within the combustion chamber. With the Lane type of generator, water-gas would be burned outside the retorts until they

<sup>19</sup> U. S. P. 1,345,905/1920.

<sup>20</sup> U. S. P. 1,102,716/1914.

<sup>21</sup> U. S. P. 1,144, 730/1915.

<sup>22</sup> U. S. P. 1,118 595/1914.

<sup>23</sup> U. S. P. 1,300,831/1919.

are sufficiently hot to promote combustion of a water-gas-air mixture within the retorts. The heat of reaction is thereby absorbed by the contact mass which finally achieves a temperature sufficiently elevated for reduction to be carried on. In the single-retort type, the reaction material is raised to reaction temperature by combustion of the reducing gas with air within the reaction system. Thereafter, in every case, a normal cycle of reduction and oxidation may be maintained.

*The Reduction Phase.*—The normal reducing agent employed is blue water-gas. Other technical gases, such as air-producer gas, semi-water-gas and special producer gases with high carbon monoxide content have all been tried and used, but they are all inferior to blue water-gas. This is doubtless due to the high concentration of inert constituents which such gases contain whereas, with water-gas, these inert constituents are reducible to a minimum. The reduction process is by no means a rapid one and hence a high concentration of reducing agent is desirable. As to specifications in the water-gas employed, opinion is unanimous as regards the necessity of employing gas free as far as possible from dust and from sulphur compounds. Therefore, the water-gas is submitted to a rigorous scrubbing in a coke-filled scrubber condenser and is then freed from sulphuretted hydrogen. The normal iron-oxide box treatment of the gas industry is usually employed for this purpose—passage of the gas through large rectangular or circular boxes filled with a mixture of moist hydrated oxide of iron and wood shavings to lighten the material—a ten-minute time of contact being sufficient. Some very recent investigations,<sup>24</sup> have for their object the removal of the bulk of the sulphuretted hydrogen by scrubbing with a suspension of iron hydroxide in water, to be followed by a final purification by the normal box treatment. In this way the heavy cost associated with the charging and discharging of the iron-oxide box system may be reduced.

Removal of dust prevents choking of the retorts with non-active or with carbonaceous material. Removal of the sulphuretted hydrogen increases the efficiency of the process by minimising the extent to which the iron contact mass is converted into sulphide. This is harmful for several reasons. Sul-

<sup>24</sup> See for example: Evans, *Gas Record*, 1919, 15, 215.

phide of iron tends to promote fusion of the reaction material at the temperatures employed. Also, the protective coating of sulphide decreases the extent of active surface. Further, it reacts partially with the steam and so introduces sulphur gases into the hydrogen produced in the succeeding steaming operation. It must be observed, however, that the iron-oxide box treatment does not remove all sulphur compounds from the water-gas. Carbon disulphide and organic sulphur compounds in small concentrations remain in the water-gas and these produce, to a lesser extent, however, the disadvantages associated with the use of a gas containing sulphuretted hydrogen. Indeed, it is probably through hydrogen sulphide that the effect proceeds since, under the given conditions, the catalytic action

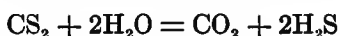

readily occurs on passage of water-gas containing carbon disulphide through the iron contact mass.

Specifications on carbon monoxide, carbon dioxide and hydrogen contents of the water-gas vary largely, and are adapted to the mode of operation employed. Thus, in one case, a low reaction temperature is employed and a water-gas containing a minimum of carbon dioxide, averaging 3 per cent, is employed. In this case efficient reduction is attained and a low ratio of water-gas used to hydrogen produced is possible, thus making for economy of operation.

It is apposite, at this point, to amplify the theoretical bases underlying this concept of water-gas-hydrogen ratio since the amount of water-gas consumed in the reduction process is an important factor in the economy of the process. As pointed out earlier in the chapter, the reactions occurring are equilibrium processes, which, at the temperatures involved, are incomplete in either direction. If the simplifying assumptions be made that the reactions occurring are

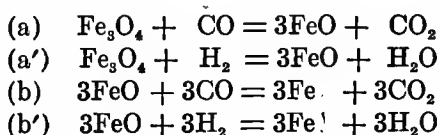

and that they occur to equal extent as regards reaction of carbon monoxide and hydrogen it may be calculated, from the equilib-

rium data given earlier, that, of a water-gas composed of equal volumes of hydrogen and carbon monoxide, the following percentages of these gases would be consumed in the reduction process when equilibrium was established, at various operating temperatures. For more exact figures see Appendix I.

$\text{Fe}_3\text{O}_4 - \text{FeO}$  REACTION

<i>Temperature</i>	<i>% H<sub>2</sub> Consumed</i>	<i>% CO Consumed</i>	<i>Water-Gas: H<sub>2</sub></i>
650	42	64	1.8
750	56	70	1.6
850	66	80	1.4

$\text{FeO} - \text{Fe}$  REACTION

<i>Temperature</i>	<i>% H<sub>2</sub> Consumed</i>	<i>% CO Consumed</i>	<i>Water-Gas: H<sub>2</sub></i>
650	30	41	2.85
750	33	40	2.77
850	41	35	2.63

Now the volume of reducing gas oxidised in the reduction process represents also the volume of hydrogen subsequently obtained in the subsequent steaming process. Hence, it is easy to calculate the volume of hydrogen produced from 200 volumes of water-gas and hence the ratio of water-gas consumed to hydrogen which may be theoretically produced. These calculations are tabulated in the last column. It is at once evident that it would be more economical of water-gas to work on the  $\text{Fe}_3\text{O}_4 - \text{FeO}$  cycle and this is largely recommended in practice. It must be observed, however, as reference to the equations at once shows, that only one-fourth the yield of hydrogen per unit of ore is obtained.

Too much stress must not be laid on such calculations, however, since they were made with certain simplifying assumptions. It was assumed that equilibrium conditions hold over the whole reducing phase, which is not always true, especially towards the end of a reduction phase when the bulk of the surface oxide has been reduced. Furthermore, it was assumed that hydrogen and carbon monoxide were equally attacked whereas it is known that hydrogen is the more reactive reducing agent. Owing, how-



ever, to the ready interaction of carbon monoxide with the steam produced by the oxidation of the hydrogen, according to the equation of the water-gas reaction

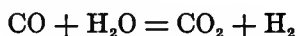

carbon monoxide also disappears rapidly. Indeed, when measured over a sufficiently short interval of time, the exit carbon monoxide, carbon dioxide, hydrogen and steam are present in the ratios determined by the equilibrium constant of this water-gas reaction at the operating temperature (see Chapter III).

$$K = \frac{[\text{CO}] [\text{H}_2\text{O}]}{[\text{H}_2] [\text{CO}_2]}$$

But, since the amount of oxide of iron to be reduced becomes less and less as the reducing phase continues, the relative amounts of carbon dioxide and steam formed become less and less. This continuously changing extent of reaction with time vitiates any complete simple theoretical treatment. The point of view presented will therefore be regarded as sufficient to indicate in a qualitative manner the reasons why considerably more than unit volume of water-gas must be consumed to produce one volume of hydrogen.

In the later stages of the reducing period, when a large surface of reduced iron is exposed to the incoming gases, another catalytic action is rapid at the prevailing temperatures. Reduced metals, more especially, nickel and iron, catalyse the reversible reaction



At a given temperature definite concentrations of the two gases are in equilibrium with carbon. If carbon monoxide be in excess, reaction occurs in the direction of equilibrium with simultaneous deposition of carbon. It is in this way that carbon is introduced into the contact mass. The carbon thus deposited is extremely reactive and yields, in the subsequent steaming phase, both carbon monoxide and carbon dioxide, the former of which is frequently a very detrimental impurity in hydrogen.

To prevent deposition of carbon, various devices are used. Thus, the Dellwick-Fleischer<sup>25</sup> purity-steam process seeks to ef-

<sup>25</sup> B. P. 21,479/1908.

fect this by introducing steam along with the reducing gas. In this manner, owing to the operation of the water-gas equilibrium

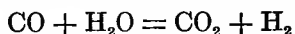

the reducing agent becomes mainly hydrogen and the ratio of  $\text{CO}_2 : \text{CO}$  is kept high, thus diminishing the tendency towards decomposition of carbon monoxide. Maxted,<sup>26</sup> for the same purpose, utilises a reducing gas containing a  $\text{CO}_2 : \text{CO}$  ratio definitely higher than that corresponding to the equilibrium ratio in the reaction



The presence of carbon dioxide to the extent of at least twice the volume of carbon monoxide is advised.

The same result is achieved in the procedure adopted in the most recent types of Messerschmitt plant. The reducing agent in this case is a partially burnt water-gas. The carbon dioxide, carbon monoxide ratio is high and therefore prevents or reduces the deposition of carbon on the reacting substance.

From the tables of gas consumption in the reducing phase already given it is obvious, however, that this prevention of carbon deposition is only secured at the expense of the ratio of water-gas consumption to hydrogen produced. The expense item for water-gas will be correspondingly increased. Furthermore, the presence of carbon dioxide and steam undoubtedly cuts down the rate at which hydrogen and carbon monoxide act as reducing agents.

In actual practice, all variations between the two extremes,—(a) water-gas of low carbon dioxide content, with rapid and efficient reduction with, however, tendency to carbon deposition and (b) high concentration of carbon dioxide with corresponding slower and less economic reduction with less tendency to carbon deposition—are to be found. The actual procedure is governed by many considerations both of technique and of utilisation of the hydrogen.

Actual figures taken from a hydrogen plant operating on the multi-retort system gave the following analyses for water-gas used, spent water-gas issuing from the retorts and the same after removal of the steam.

<sup>26</sup> B. P. 12,698/1915; U. S. P. 1,253,622/1918.

	$H_2$	$H_2O$	$CO$	$CO_2$	$N_2, Etc.$
Water-Gas (dry basis)	50	—	42	5	3
Spent Water-Gas....	25	25	12	35	3
Spent Water-Gas (dry basis) .....	33.3	—	16	46.3	4.4

The plant in question was operated at a temperature averaging 700° C. In the Messerschmitt type of plant similar figures will be obtained for the original water-gas. For the gas leaving the contact mass, there will be a larger amount of diluent nitrogen introduced as air in the preliminary partial combustion in the checker brick chamber. The presence of this diluent nitrogen, lowering the partial pressures of the actual reducing gas as well as the utilisation of some of the reducing gas in the combustion process inevitably results in a higher ratio of water-gas consumed to hydrogen actually produced in this method of operation.

The best practice in respect to water-gas: hydrogen ratio over a fair interval of time, in which the variable activity of a contact mass may be noted, seems to yield, in multi-retort units, a figure of 2.5 : 1. One volume of hydrogen is produced at the expense of two and one-half volumes of water-gas. This figure refers to a plant containing many units with as nearly as possible continuous operation. Stoppages of the plant raise this figure considerably, since, in such cases, water-gas has to be consumed to maintain retort temperatures during stoppages of the plant, without corresponding hydrogen yield. With decrease in plant size and increased intermittency of working the water-gas consumption rises markedly and becomes a most serious cost item. Under such conditions as much as 4-5 volumes of water-gas may be consumed.

For large-scale operation with high efficiency in respect to water-gas-hydrogen ratio, the use of meters for both water-gas and hydrogen cannot be too strongly urged. A constant check can be kept in this manner on the variation in efficiency of the process, with accidental variations in temperature, with the varying care with which the plant is operated and with the life of the reaction material. Experience has shown that such check on the process tends continuously towards high operating efficiency.

Finally, with reference to the delivery of the reducing gas to the retort system, care is needed to prevent the possibility of its contaminating the hydrogen mains. The reducing gas is generally driven from the generator, by means of a booster, through the purification system to a water-gas holder. The head of water in the holder is adequate to drive the gas through the retort system. It should be arranged, however, that this head of water is less than that prevailing in the hydrogen mains. Failure to observe this has resulted in contamination much more serious than that due to carbon deposition in the reaction mass. R. & J. Dempster, Ltd.,<sup>27</sup> of Manchester, England, provide a special automatic pressure regulating device with their plant in order to ensure the attainment of this pressure distribution.

*The Steaming Period.*—The reduction phase is immediately succeeded by the steaming period. Delivery of water-gas is stopped and steam turned into the reaction system by the operation of a single valve or a system of valves.

For simplicity of discussion a unit of 36 retorts, operated as a whole and not in three sets of twelve, will be considered. With the dimensions previously given (p. 31) the internal volume of the retorts is approximately 160 cubic feet and the unit has a capacity of 3,500 cubic feet per hour containing two 10-minute steaming periods. This yield of 3,500 cubic feet is by no means evenly distributed over the twenty minutes actually involved. As in the reducing phase, the active surface rapidly decreases, in this case by interaction of the iron or ferrous oxide with the steam. The hydrogen yield, per minute interval, progressively decreases throughout the period to an extent determined by the activity of the contact mass. With fresh, reactive material the decrease in yield with time is much smaller than with an old, non-reactive mass. In the average case, a yield of 250 cubic feet in the first minute's steaming and one of less than 100 cubic feet in the last minute will be obtained. The variation in yield with time may be used, as well as the water-gas: hydrogen ratio, as a criterion of the reaction mass.

The utilisation of the steam to yield hydrogen likewise progressively decreases with time, over the given interval. The actual ratio of steam to hydrogen varies with varying practice. In one case, in which an average amount of steam was consumed,

<sup>27</sup> B. P. 16,893/1914.

the steam: hydrogen ratio in the first minute was 5 : 3 and, in the last minute of the run, as much as 7 : 1, averaging throughout a ratio of 3 : 1. Assuming a free space of 75 per cent inside the retort system, the volume of water gas in the retorts at the commencement of steaming is

$$\frac{160 \times 75}{100} = 120 \text{ cubic feet.}$$

With a first minute yield of 250 cubic feet of hydrogen and a steam: hydrogen ratio of 5 : 3, it is obvious that

$$\frac{120}{250} \times \frac{3}{5} \times \frac{60}{1} = 17 \text{ seconds.}$$

will be the time approximately occupied in removing the spent water-gas from the retort system. Consequently, for a period, varying from 15 to 30 seconds in practice, after the steam is turned on, the gases swept out by the incoming steam follow the spent water-gas. They are then directed into the hydrogen main. By means of this period of "scavenging" or "purging" the purity of the hydrogen is materially increased.

It is not possible, however, to eliminate entirely the presence of impurities in the hydrogen produced by this means. As outlined in the previous section, unless a special modification of the reducing gas is employed, carbon is deposited on the contact mass and sulphide of iron is formed. These substances react with the steam to produce carbon monoxide, carbon dioxide and sulphuretted hydrogen. A closer examination of the varying concentrations of carbon monoxide and dioxide at different intervals of the run has led to an interesting elucidation of the conditions governing their formation. By means of a carbon monoxide recorder, Rideal and Taylor<sup>28</sup> were able to show that, at the beginning of the steaming phase, the carbon monoxide was present in greater concentration than at the end of a run. With carbon dioxide the conditions were reversed. Thus, a given sample taken from the yield of hydrogen during the first minutes of a run showed a carbon monoxide concentration of 0.27 per cent while in the last minutes of the same run the concentration of the gas was only 0.11 per cent. Closer examination showed that the relative concentrations of carbon monoxide and carbon di-

<sup>28</sup> *Analyst* 1919, 44, 89.

oxide were governed by the water gas equilibrium at the temperature of operation

$$K = \frac{p_{\text{H}_2\text{O}} \times p_{\text{CO}}}{p_{\text{H}_2} \times p_{\text{CO}_2}}$$

In the initial portion of the run  $p_{\text{H}_2\text{O}}/p_{\text{H}_2}$  is small, as already stated. Hence  $p_{\text{CO}}/p_{\text{CO}_2}$  is correspondingly large. At the end of a run where the ratio, steam to hydrogen, is very high, the ratio of carbon monoxide to dioxide is low. It is evident that the iron-iron oxide contact mass is acting as catalyst, in the water-gas reaction, for the gases produced by interaction of the steam with the iron and the carbon deposited in the retort system. The carbon produced during the reducing period is always greater in amount than the carbon which interacts with steam in the subsequent operation. An accumulation of carbon therefore occurs, the removal of which is effected by aeration as later outlined. The same also is true of the accumulation of sulphur as iron sulphide, which reacts with steam and gives the hydrogen a concentration of sulphuretted hydrogen averaging 0.05 per cent.

From these considerations it follows that the purity of the gas produced in the hydrogen generator is dependent on the thoroughness of the scavenging process, the state of the retort mass in respect to carbon and sulphur accumulations, the amount of steam used in the steaming process and the temperature at which reaction occurs. An average product with a steam: hydrogen ratio of 3 : 1 and an operating temperature of 650° C. gave the following figures:

$$\begin{aligned} \text{H}_2 &= 98.5 \text{ to } 99\%; \text{ CO}_2 = 0.5 \text{ to } 1\%; \text{ CO} = 0.2 \text{ to } 0.3\%; \\ \text{H}_2\text{S} &= 0.05\%; \text{ N}_2 = 0 \text{ to } 0.25\%. \end{aligned}$$

In case carbon deposition is prevented by one or other of the methods quoted, the purity of the gas is considerably increased. Thus, Maxted quotes<sup>29</sup> for the hydrogen yielded by his modification of the steam-iron process, a gas of the composition:

$$\begin{aligned} \text{H}_2 &= 99.94 \\ \text{CO} &= \text{nil} \\ \text{CO}_2 &= \text{nil} \\ \text{N}_2 &= 0.06. \end{aligned}$$

<sup>29</sup> *J. Soc. Chem. Ind.*, 1917, 36, 779.

For the attainment of this high degree of freedom from traces of air or its components it is necessary, states Maxted, to employ heated feed water for the boiler which supplies steam for the hydrogen plant and to install tubular condensers in preference to open water scrubbers.

For the steaming process it is advisable to employ dry steam, and a working pressure of 60 to 80 lbs. is usual. By superheating the steam still further considerable advantage in operation results both as to yield of hydrogen and diminution of disintegration of the contact mass. In the Lane system and modifications of this type it is usual to use the steam at the pressure named without any superheat. The exothermicity of the reaction is sufficient to raise the steam to reaction temperature when the retorts are externally heated and even to bring about a small increase in the temperature of the retort mass. In the single retort unit, the steam is partially superheated in the checker-brick chamber surrounding the contact material.

The crude hydrogen-steam mixture, after leaving the generator, passes to a scrubber condenser where it is freed from steam and then to a purification system in which the sulphuretted hydrogen and carbon dioxide are removed. Removal of residual carbon monoxide requires a special process. In the earlier plants, a scrubber condenser was attached to each generator unit for removal of the steam. This involves an unnecessary duplication of plant and so, in more modern installations, one large scrubber to several units is employed. The scrubbers are generally coke-filled towers up which the gas mixture passes, with water flowing downwards over the coke, counter-current to the gas. For removal of the sulphuretted hydrogen and carbon dioxide, procedure varies in different plants. In some plants both impurities are removed simultaneously by passage of the gas through a system of lime boxes such as were used formerly in the gas industry and of the same type as are used in the removal of sulphuretted hydrogen. This treatment is economical of plant since only one set of four lime boxes are required in addition to the booster necessary to drive the gas through the purification system. On the other hand this method of purification is costly both in material and labor. The lime cannot be renewed owing to the formation of calcium sulphide. The labor cost is high since

the action is mainly confined to the surface of the material and frequent renewal of the lime is necessary.

The alternative procedure in respect to purification is to remove the sulphuretted hydrogen first by iron oxide box treatment or by treatment with an iron oxide sludge followed by the usual box treatment for the final traces. The carbon dioxide is then removed in scrubbers using caustic soda as the absorbent. For a large plant this alternative procedure is the more economical, especially if the spent soda absorbent be causticised and so utilised continuously in the purification system. Patents to the Badische Co. (D. R. P. 302,555 and 303,292/1916) cover the use of aqueous suspensions of iron oxide for the removal of the bulk of the sulphides followed by the use of alkaline suspensions of iron oxide containing oxalic acid for the last traces. Revivification of the spent liquor, in both cases, by blowing air through the sludge, is claimed. It is obvious that such a combination of neutral and alkaline absorbing liquors would suffice for both sulphuretted hydrogen and carbon dioxide removal.

*Aeration.*—The removal of carbon and sulphur accumulations by “burning-off” in a current of air, follows a steaming phase at regulated intervals. The frequency of the process is governed by the standard of hydrogen purity to be maintained. Over the temperature range in question oxidation is very energetic. Sulphur dioxide and carbon dioxide are the principal gaseous products of oxidation and the magnetic iron oxide itself undergoes conversion to ferric oxide

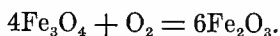

The increase in temperature of the mass due to oxidation is marked and the admission of air must be regulated so as to avoid local overheating. By carrying out this process immediately after the steaming phase, this can be done and the danger of forming an explosive mixture within the retorts considerably diminished. On completion of the aeration process it is also advisable to sweep out the air with steam before turning the reducing gas into the system again. By this method of procedure the operation can be conducted with perfect safety.

To render the burning-off process more complete, Blair and Ferguson<sup>30</sup> have recently patented the use of enriched air ob-

<sup>30</sup> B. P. 143,064/1920.



tained by adding, to the air normally employed, oxygen from suitable source. It may be presumed that the extra purity of the hydrogen thus obtained compensates for the increased cost of the enriched air employed.

*The Thermal Balance of the Process.*—From the usual thermal data for the reactions of the steam-iron process:

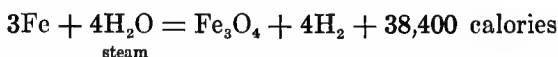
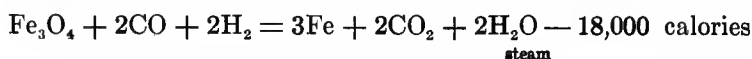

it is evident that the whole process should be exothermic, since the loss of heat in the reduction process is outbalanced by the heat evolution in the steaming phase.

The problem, however, is by no means so simple as such a statement would indicate. In the first place the data refer to reaction at room temperatures, whereas the reaction occurs in the interval 650-850° C. Secondly, the above equations imply that the alternation is between metallic iron and magnetic oxide of iron, whereas test shows that a marked amount of ferrous oxide is present after a reduction phase. Furthermore, the first equation implies that carbon monoxide and hydrogen are equally consumed in the reduction process, whereas, as was previously pointed out, a greater proportion of carbon monoxide is apparently used up. This undoubtedly arises from the setting up of the water-gas equilibrium in the gases as they leave the contact mass, since hydrogen is known to reduce oxide of iron more rapidly than does carbon monoxide.

A detailed analysis of each of these separate factors in the question of thermal balance leads to a very complex thermochemical problem, the unsatisfactory nature of which is emphasized by the uncertainty which attaches to the equilibrium data of the several gases and the oxides concerned (see p. 25). A simpler method of analysis is therefore substituted.

It is apparent that the heat required, at any temperature, for reduction of magnetic oxide of iron by hydrogen to any lower state of oxidation will be exactly equal to that evolved in the subsequent reconversion of the material to the ferrous-ferric condition in presence of steam. From the equations

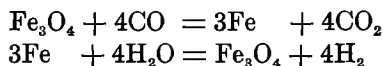

or from the corresponding equations for ferrous oxide formation it is also evident that for every molecule of carbon monoxide used in the reducing stage a molecule of steam is used in the oxidation stage, so that the net thermal change involved is the heat of the reaction

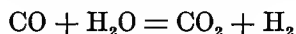

at the temperature of operation. This can be accurately calculated at any temperature from the thermal data for the heats of formation of these gases and from their specific heats, all of which magnitudes are known with great exactness.<sup>31</sup> Recent values for these quantities give a heat of reaction at 15° C. of 10,500 calories and at any other temperature  $t^\circ$  C. the heat of reaction is deducible from the equation

$$Q_t = 10,500 + (t - 15) (-0.535 - 0.0028t + 0.95 \times 10^{-6}t^2 + 0.1 \times 10^{-9}t^3)$$

At the average temperature, 700° C., of a steam-iron process unit, this gives a result

$$\begin{aligned} Q_{700} &= 10,500 + 685 (-0.535 - 0.0028 \times 700 + 0.95 \times 10^{-6} \times 700^2 + 0.1 \times 10^{-9} \times 700^3) \\ &= 10,500 + 685 (-0.535 - 1.96 + 0.46 + 0.0343) \\ &= 10,500 + 685 (-2.00) = 10,500 - 1,370 \\ &= 9,130 \text{ calories.} \end{aligned}$$

For every gram molecule of carbon monoxide used up in the reducing phase (which may readily be determined from analysis of the water-gas employed and spent water-gas leaving the retorts) the net positive thermal change is 9,130 calories, when the reaction temperature is 700° C. Transposed into the units employed in industry this amounts to 45.7 B. th. U.'s per cubic foot of carbon monoxide (at 20° C. and 760 mm. pressure), when the reaction is carried out at a temperature of 700° C. This value decreases slowly with increase of temperature. At 1,000° C., however, it is only some 10 per cent less.

Reference to figures given in the preceding sections of this chapter shows that, of 100 volumes of water-gas, approximately

<sup>31</sup> Slegel: *Z. physik. Chem.*, 1914, 87, 641.

30 volumes of carbon monoxide and 25 volumes of hydrogen suffer oxidation in their passage through a retort system at a working temperature of about 700° C. For the production of 1 volume of hydrogen, therefore, the water-gas consumed is

$$\frac{100}{30 + 25} = \frac{100}{55} = 1.8 \text{ volumes.}$$

Furthermore, three volumes of steam are used to produce one volume of hydrogen. Consequently, in the oxidation of one volume of carbon monoxide during the reducing phase, the volume of water-gas passed through

the system is  $\frac{100}{30} = 3.3$  volumes of water-gas and subsequently

$$\frac{100}{30} \times \frac{3}{100} = 5.5 \text{ volumes of steam are used to oxidise the}$$

iron or ferrous oxide formed in the reducing phase. The mean molecular heats of water-gas and steam are calculable from the equations

$$C_p : H_2 = 6.685 + 0.00045 t$$

$$C_p : CO = 6.885 + 0.00045 t$$

$$C_p : H_2O = 8.050 + 0.0005 t + 0.2 \times 10^{-9} t^3.$$

With these data, the heat required to raise 3.3 gram molecules of water-gas (1.65 gram molecules  $H_2$  + 1.65 gram molecules CO) from 15° to 700° and 5.5 gram molecules of steam from 100° to 700° may be shown to be

$$\begin{aligned} 685(3.3(6.785 + 0.00045 \times 700) ) + 600(5.5(8.050 + 0.0005 t + \\ 0.2 \times 10^{-9} t^3) ) \\ = 16,050 + 27,930 \\ = 43,980 \text{ calories.} \end{aligned}$$

It is therefore evident that, while the chemical reactions occurring at 700° C. show a small positive thermal balance of 9,130 calories per gram molecule of carbon monoxide oxidised in the reducing phase, this heat of reaction is not sufficient to raise the temperature of the incoming water-gas and steam to the reaction temperatures. The calculations made, clearly show the necessity for heat other than that obtainable from the total reaction process. The devices previously detailed, namely, the external

heating of the retorts, combustion of some of the water-gas within the retort system, superheating of the incoming water-gas and steam are all methods whereby the heat of reaction is assisted in supplying the heat required to raise the gases employed to the reacting temperatures or to keep the contact mass at the desired heat.

The efficiency of such methods of maintaining reaction temperature can now readily be calculated in the multi-retort process, in which the spent water-gas, after removal of the steam, is all burned on the outside of the retort. In the case thus far considered the spent water-gas has the composition:  $H_2 = 25\%$ ;  $H_2O = 25\%$ ;  $CO_2 = 35\%$ ;  $CO = 12\%$ . In addition to this spent gas the first fraction of the hydrogen produced, the hydrogen employed in the "scavenging" of the retort system, is also burned around the retorts. About 10 per cent of the hydrogen yield is so consumed. In the case under consideration this would be 10 per cent of 55 volumes produced after the reduction process, which involved 30 volumes of carbon monoxide and 25 volumes of hydrogen.

Now, since

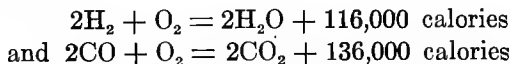

the furnace efficiency is readily shown to be

$$\frac{(43,980 - 9,130) \times 30 \times 2 \times 100}{(25 + 5.5) \times 116,000 + 12 \times 136,000} = 40.5 \text{ per cent.}$$

Expressed otherwise, 60 per cent of the heat generated on the outside of the retorts in a multi-retort system is not utilised in the reaction process.

This result derived from theoretical considerations and experimental data on water-gas and steam consumption is familiar to anyone who has had control of a steam-iron process multi-retort unit. A major portion of the external heat generated is radiated into the surrounding atmosphere. The excessive amount of this heat loss is the more remarkable when it is remembered that no provision for possible heat exchange between inlet and exit gas or steam has been assumed. It is safe to say that, of the net thermal deficiency on the whole reaction (inclusive of heat required to raise the incoming gas or steam to reaction tempera-

tures) probably 75 per cent could be provided by heat exchange. Assuming such a figure, it follows that the thermal efficiency of the process would be of the order of 8-10 per cent, in which case 90 per cent of the heat available in the spent water-gas is lost.

An approximate experimental check on these figures is given by some determinations of Lundén and Thorsell in Sweden who calculated the radiation from a plant producing 4,000 cubic feet of hydrogen per hour. The radiation was determined to be of the order of 470,000 Kilogram calories per hour. Assuming the calorific value of water-gas to be 75 Kilogram calories per cubic foot, this corresponds to the consumption of 6,400 cubic feet of water-gas, or 1.6 volumes of water-gas per volume of hydrogen produced. This is of the order of 66 per cent of the total water-gas used in the process.

Record has already been made of the efforts to minimise heat losses by the use of a single ore chamber instead of a multiple retort system. No very considerable economies in water-gas consumption have, however, been recorded as a result of their use. Possibly this is because of the difficulty of utilising spent water-gas largely diluted with nitrogen, as is the gas after use as a reducing agent in this type of plant. Also, reduction with a gas already containing a high concentration of carbon dioxide is relatively inefficient.

Jaubert, in French practice, attempts economy of reducing agent in multiple retort practice by working at a lower temperature. The practical effect of this is two-fold. A larger proportion of carbon monoxide relative to hydrogen in the water-gas is consumed. This is in accord with the equilibrium in the water-gas reaction:

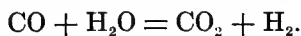

The equilibrium constant,

$$K = \frac{p_{\text{CO}} \times p_{\text{H}_2\text{O}}}{p_{\text{CO}_2} \times p_{\text{H}_2}}$$

decreases with decreasing temperature (see page 61). In other words, carbon monoxide and steam concentration in the spent water gas decrease, while carbon dioxide and hydrogen concentrations increase, the lower the reaction temperature. This greater

utilisation of the carbon monoxide means an increased positive thermal effect in the reduction process. At the same time, lower retort heats mean lower losses by radiation and less heat consumed in raising gas and steam to reaction temperatures. The lower limit to which this can be carried is governed by the reactivity of the contact mass. As the temperature decreases, reactivity, and therefore output per unit of contact mass, also falls.

That attention is being directed in technical practice to a better utilisation of the spent water-gas is evidenced by a recent series of patents. R. and J. Dempster, Ltd.,<sup>32</sup> of England, claim the use of spent water-gas for the earlier part of the reducing phase. Fresh reducing gas is then passed through the retorts for the completion of the reduction and is then either passed away or conditioned for use in the earlier part of the reduction phase. The conditioning provided appears to be the removal of steam. A later patent<sup>33</sup> provides a method of control of waste gases burned, whereby the volume of the outgoing waste gases is restricted during the exothermic, oxidising or steaming phase and the maximum heating effect of the gases is obtained during the reducing phase. The controlling device is operated in connection with the hydrogen valve.

Harger and Lever Bros., Ltd.,<sup>34</sup> utilise the spent gas obtained after reduction of the iron oxide by passing it over copper oxide arranged adjacent to the iron. The heat of the reactions

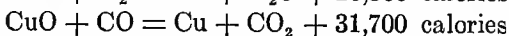
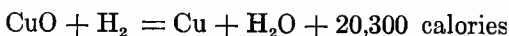

is applied to heat the iron material. The usual steaming phase is then carried out and the hydrogen collected. This is followed by an air blast which serves to reoxidise the copper to copper oxide and by means of the heat of reaction

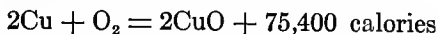

supplies additional heat to the reaction system. The carbon dioxide, hydrogen and nitrogen produced in the three successive stages of the process, reduction, steaming and air blast, may be separately collected. Owing to the exothermic nature of the ad-

<sup>32</sup> B. P. 126,251/1918 and 126,256/1918.

<sup>33</sup> B. P. 131,347/1918.

<sup>34</sup> B. P. 131,684/1918.

ditional reactions in this system it is to be anticipated that external heating of any kind would be unnecessary. The ratio of water-gas consumed to hydrogen produced could, in such case, be kept down to that required by the equilibrium data for the several gases in contact with iron and the iron oxides, whereas, in many installations now working, this ratio is greatly exceeded.

The British Oxygen Co., Balfour and Bray<sup>35</sup> contemplate the use of spent water-gas after an even more thorough purification than claimed in the Dempster patents just cited. The spent water-gas before re-employment is to be freed from steam, carbon dioxide and sulphur compounds, and then used in the retorts for reduction purposes.

The data already given enable one to determine the relative calorific values of the hydrogen into the holder and of the water-gas consumed. This figure, which is of importance when hydrogen is to be put to use as fuel is, however, of secondary importance in processes in which the hydrogen is used as a hydrogenation agent. From the calorific data and volume relationships already given it follows that the calorific efficiency of hydrogen produced to water-gas consumed is

$$\frac{0.9 \times 55 \times 116,000 \times 100}{50 \times 116,000 + 42 \times 136,000} = 49.8 \text{ per cent.}$$

<sup>35</sup> B. P. 144,751/1919.

## Chapter III.

### Hydrogen From Water-Gas and Steam.

*Theoretical.*—In the water-gas generator, in addition to hydrogen and carbon monoxide, a small proportion of carbon dioxide is normally produced and, as is well known, the percentage of carbon dioxide increases the lower the temperature of the fuel bed. Examination shows that this carbon dioxide is most probably produced from the carbon monoxide formed in the initial reaction

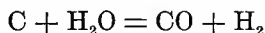

by further interaction of the gas with steam according to the so-called water-gas reaction:

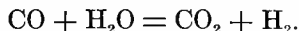

This reaction is in reality an equilibrium process, the direction of the reaction being governed by the temperatures maintained and the concentrations of the respective components. The velocity with which the reaction occurs is largely determined by the nature of the solid material in contact with which the reaction is carried out. A number of substances accelerate the velocity of reaction by acting as catalytic agents. In the fuel bed of the water-gas generator it is probably the mineral constituents forming the ash of the coke employed which assist in the promotion of the water-gas reaction.<sup>1</sup> Actual experimental determinations of the equilibrium in a range of temperatures extending from 686° C. to 1,100° C. made by Hahn have permitted the deduction of an equation<sup>2</sup> representing the variation of the equilibrium position with temperature. By means of the equation

$$\log K = \log \frac{p_{\text{CO}} \times p_{\text{H}_2\text{O}}}{p_{\text{CO}_2} \times p_{\text{H}_2}} = - \frac{2116}{T} + 0.783 \log T - 0.00043 T$$

<sup>1</sup> See Gwosdz, *Z. angew. Chem.* 1918, 1, 137.

<sup>2</sup> *Z. physik. Chem.* 1902, 42, 705; 1903, 44, 513; 1904, 48, 735.



the following table of values, extrapolated below 700° C. but fitting the experimental data from that temperature onwards, has been compiled.

T° C.	400°	500°	600°	700°	800°	900°	1,000°
$K = \frac{P_{CO} \times P_{H_2O}}{P_{CO_2} \times P_{H_2}}$	0.05	0.15	0.32	0.58	0.90	1.25	1.62

At the high temperature of the water-gas generator, since the concentration of steam will simultaneously be low, it is obvious that the concentration of carbon monoxide will considerably exceed that of carbon dioxide. This is confirmed by the following typical analysis of a water gas:

Hydrogen .....	47.1 per cent
Carbon monoxide .....	42.6
Carbon dioxide .....	3.1
Nitrogen .....	3.5
Methane .....	0.4
Sulphur compounds .....	0.2
Water vapor .....	3.0

Also, it is evident that, at lower temperatures, especially if steam be present in excess, the production of carbon dioxide with simultaneous formation of hydrogen is favored. It is such conditions which are maintained in methods of hydrogen production by water-gas catalytic processes.

As the temperature is decreased, the rate at which reaction occurs is diminished. Consequently, in practice, a lower limit of operating temperature will be set, below which the attainment of equilibrium conditions is impracticably slow. The limit of temperature will be lower the more efficient the agency employed to assist reaction catalytically, after the manner of the ash content of the coke. Assuming a catalyst which enables the reaction to proceed at a sufficient speed at 500° C. and a ratio of steam to hydrogen in the exit gases of 2 : 1 it follows from the equilibrium data that the ratio of carbon monoxide to carbon dioxide will be given by the equation

$$K_{500^\circ} = \frac{P_{CO}}{P_{CO_2}} \times \frac{P_{H_2O}}{P_{H_2}}$$

$$\text{or} \quad 0.15 = \frac{P_{\text{CO}}}{P_{\text{CO}_2}} \times \frac{2}{1}$$

$$\text{whence} \quad \frac{P_{\text{CO}}}{P_{\text{CO}_2}} = 0.07$$

In other words, carbon monoxide will be present in the exit gases to the extent of 7/100ths of the carbon dioxide content. In this way, water-gas relatively rich in carbon monoxide and poor in carbon dioxide may be converted to a gas poor in carbon monoxide and rich in carbon dioxide. And since, simultaneously with the formation of carbon dioxide, hydrogen is produced, the exit gases from an equilibrium reaction at 500° C. will be relatively rich in hydrogen. This is the fundamental basis of the water-gas catalytic process as established technically by the Badische Co. as a method of preparation of cheap hydrogen for ammonia synthesis.

Theoretically, it is possible still further to depress the carbon monoxide concentration in the exit gases from the water-gas reaction. From the expression for the equilibrium constant

$$K = \frac{P_{\text{CO}} \times P_{\text{H}_2\text{O}}}{P_{\text{CO}_2} \times P_{\text{H}_2}}$$

it is evident that if, at any given temperature of reaction, means be adopted to diminish the concentration of either the carbon dioxide or hydrogen resulting from the change, the effect of this will be still further to diminish the concentrations of the reacting carbon monoxide and steam. Now it is not desirable to withdraw hydrogen as formed since this is the product desired. But, if the carbon dioxide concentration be maintained as low as possible, the percentage of carbon monoxide will be correspondingly lowered. A ready means of keeping the carbon dioxide concentration low is at hand in the utilisation of the fact that lime will absorb carbon dioxide readily from moist gases even at 500° C. to form calcium carbonate. Absorption by lime continues until equilibrium is set up, at the given temperature, in the reaction

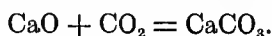

Now, at every temperature, there is a definite partial pressure of carbon dioxide in equilibrium with the lime and calcium carbonate, the dissociation pressure of calcium carbonate. This has been accurately determined by Johnston<sup>3</sup> and has been shown to give the following values over the range of temperatures here in question:

T° C.	587	605	631	671	680	691	711
PCO <sub>2</sub>	1.0	2.3	4.0	13.5	15.8	19.0	32.7 mm.

Therefore, so long as the water-gas reaction be conducted at 587° C. in the presence of an excess of lime the maximum partial pressure of the carbon dioxide which may be present is 1 mm. Hence, since,

$$K = \frac{PCO \times PH_2O}{PCO_2 \times PH_2} \text{ or } \frac{PCO}{PCO_2} = K \frac{PH_2}{PH_2O}$$

it follows that by repressing in this manner the carbon dioxide concentration from a concentration of about 13 per cent, which it would have in the exit steam-gas mixture of the simple continuous catalytic process already discussed, to a partial pressure of 1 mm. or approximately 0.13 per cent in presence of lime, the carbon monoxide can be depressed in the like ratio. The theory of conducting the water-gas reaction in presence of lime is the basis for the patented process of the Griesheim-Elektron Company, which forms the second method of hydrogen production from water-gas and steam which will receive consideration.

The proposals embodied in a series of patents obtained by Dieffenbach and Moldenhauer represent an attempt at a simplified mode of operation of both these methods of hydrogen production. The simplification attempted lies in the effort both to produce water-gas and to throw the water-gas equilibrium over to the carbon dioxide-hydrogen side in a onestage process. By suitable treatment of the carbon it is sought to increase its activity towards steam and at the same time to increase the reaction velocity of the water-gas reaction in the presence of carbon dioxide absorption agents to such an extent that hydrogen and carbon dioxide, substantially free from carbon monoxide, leave the fuel

<sup>3</sup> *J. Am. Chem. Soc.*, 1910, 32, 938.

bed. The details of such proposals will be discussed in the last section of the chapter.

### *The Continuous Water-Gas Catalytic Process*

*Outline of the Process.*—Water-gas and steam are admixed, raised to a temperature of approximately 450° C. by means of heat exchangers, and are passed over a suitable catalytic agent. The water-gas reaction is brought about as represented by the equation:

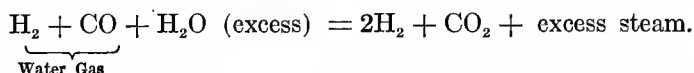

The sensible heat of the gases leaving the catalytic agent is given up to fresh incoming gases in the heat exchangers and the gas is then freed from steam in condensers. The resulting mixture contains about 2-3 per cent of carbon monoxide (dry basis), the residue consisting mainly of hydrogen and carbon dioxide approximately in the ratio of 2: 1. In the succeeding operation, the carbon dioxide (30-35 per cent) and sulphuretted hydrogen are removed, generally by washing with water under a working pressure of 15-40 atmospheres. The residual gas, containing approximately 95 per cent hydrogen, 3 per cent of carbon monoxide, residual nitrogen and methane, may be used as such in certain operations or may be submitted to special purification processes.

*Catalysts for the Reaction.*—A résumé of the patent literature will serve to indicate the various proposals which have been made to accelerate the reaction between the carbon monoxide and steam.

Hembert and Henry proposed the use of fireproof materials at a red heat to promote reaction between water-gas and excess of steam. Read in B. P. 3,776/1885 suggested the use of metallic oxides as catalysts. The patent granted to Mond and Langer (B. P. 12,608/1888) claimed the removal of carbon monoxide and hydrocarbons from fuel gases by passage with excess of steam over heated catalysts, for example, nickel at temperature of 350-400°, cobalt at 400-450°. The hydrocarbons were said to be decomposed, while the carbon monoxide was claimed to be practically completely eliminated. Ellworthy suggested the use of nickel or iron in a similar manner with a mixture of water-gas and steam

(Fr. P. 355,324/1905), while an earlier patent of Pullman and Ellworthy (B. P. 22,340/1891) proposed to separate the carbon dioxide by processes of diffusion and of fractional solution. The Compagnie du Gaz de Lyons (Fr. P. 375,164/1906) claimed the use of iron oxide at 600°. A year later Vignon (B. P. 20,685/1907) applied for a patent for a process as above, using iron, or oxides, or platinum at red heat, but the application was not granted. Ellis and Eldred (U. S. P. 854,157/1907) employed nickel, iron, or manganese for catalytic agents, using a specially designed superheated reaction chamber. Näher and Müller (B. P. 20,486/1911) suggest the use of a contact mass of rhodium or palladium asbestos at a working temperature of 800°. A product containing less than 0.4 per cent of carbon monoxide is claimed. It is obvious from the equilibrium considerations already given that, at the temperature stated, such a low content of carbon monoxide could only be obtained by the use of a prohibitively large excess of steam.

The technical development of the process was undertaken by the Badische Anilin und Soda Fabrik and resulted in a series of patents in the interval from 1912 down to the present time. It will be seen that several of the claims put forward by them are clearly anticipated in the preceding patents. Others, however, show definite modifications of earlier practice.

B. P. 26,770/1912, or its analogue U. S. P. 1,157,669, calls for the carrying out of the process under pressures of 4-40 atmospheres at temperatures between the limits of 300 and 600°, using nickel, cobalt or iron as catalysts. The increase in pressure facilitates both reaction velocity and heat exchange. The process is stated to be specially applicable to gases with small carbon monoxide content, though no record is available as to any technical utilisation of the patent. A somewhat later patent<sup>4</sup> claims an improvement for the maintenance of the requisite temperature in the catalytic mass by the addition of air or oxygen. This gas can be admitted in sufficient amount to make the process thermally self-sustaining, owing to the heat of interaction of the oxygen with hydrogen. The steam required for the water-gas reaction may be supplied wholly or in part in this manner. Various patents<sup>5</sup> claim the use of specially prepared catalysts composed

<sup>4</sup>B. P. 27,117/1912; U. S. P. 1,200,805.

<sup>5</sup>B. P. 8,864/1913; 27,955/1913; U. S. P. 1,114,096; 1,113,097; 1,115,776.

of oxide of iron with suitable binding agents and of nickel incorporated with various support materials. The use of catalysts containing nickel apparently tends towards the simultaneous production of methane since B. P. 27,963/1913 (U. S. P. 1,330,772/1920) deals with catalysts with which the tendency to methane production is minimised or suppressed. The materials cited in this patent are numerous and the patent represents a distinct departure from previous claims in that the use of one or more promoters in conjunction with a substance acting as basic catalyst is covered. The principal claims are for iron oxide in admixture with oxides of chromium, thorium, aluminium, nickel, with other mixtures of oxides such as those of zinc, lead, copper, uranium, etc. A later patent<sup>6</sup> returns to the earlier claims of B. P. 27,955/1913 and specifies forms of oxide of iron more rugged than the materials earlier suggested for use in technical work. Oxide, hydroxide and carbonaceous iron ores, employed either in bulk or brought into suitable form by powdering and admixture with binding agents are claimed as the catalytic agents. The minerals employed should preferably be low in sulphur, chlorine, phosphorus and silicon. High temperatures are to be avoided in the production of such agents, a limit being set at 650°. Spathic iron ore, for example, when ignited below 650° gives an active catalyst. It is, however, friable and for technical use would probably require pulverising and briquetting with a suitable binding agent. The claims of D. R. P. 284,176/1914 (U. S. P. 1,301,151) specify the use of the oxides of rare earths, especially cerium oxide, not, as in U. S. P. 1,330,772, as promoters to other oxide agencies, but as the basic catalyst with which other activating agents may be employed.

The specifications of the Badische Co. with respect to suitable iron oxide ores exclude from use iron oxide obtained from the roasting of pyrites ores. The utilisation of this material in suitable form is the object of the patent claims of Buchanan and Maxted<sup>7</sup> who protect the use of oxide of iron obtained by lixiviation of sodium ferrite. Such material is a by-product in the causticisation of sodium carbonate by the Loewig process, in which roasted iron pyrites is used for calcination with sodium carbonate at elevated temperatures, with production of

<sup>6</sup> B. P. 16,494/1914.

<sup>7</sup> B. P. 6,476/1914.

sodium ferrite and evolution of carbon dioxide. The iron oxide obtained after lixiviation of the ferrite is an active agency for the water-gas reaction, the presence of some undecomposed ferrite probably acting as an auxiliary activator. A succeeding patent<sup>8</sup> to the same applicants claims the use of metallic couples for increased efficiency. Thus, by reduction of the iron oxide obtained in the manner just stated and by immersion of the iron thus obtained in a solution of copper salts, a metallic couple is obtained with which improved conversion at increased velocities is obtained. Similarly an iron-silver couple may be utilised.

No published data are available as to the relative activities of the many catalytic agents cited in this résumé. Furthermore, catalytic activity alone is no criterion of the suitability of a given substance or mixture for use in the process. The choice of catalyst is governed by a variety of factors of which catalytic activity is but one of importance. The robustness of the material, the economy of its preparation, density, sensitivity towards poisons, and to temperature change, are all features of the catalytic agent which require consideration and, in conjunction with catalytic activity, determine the choice. The following table, however, compiled from experimental investigations of the writer, will serve to give a degree of orientation in the matter of the relative activities of materials which have been chosen as types of the catalytic agents claimed in the patent literature just described. The experimental investigation was made with a special form of water gas having a carbon monoxide content of 38 per cent.<sup>9</sup> Small amounts of catalyst as specified in the table, were employed. The ratio of steam to hydrogen was such that, unless otherwise stated, at equilibrium at 500° C., a ratio  $H_2O : H_2 = 2 : 1$  was maintained. The speed of gas flow is indicated in the column headed, Space Velocity, which represents the volume of water-gas passed per hour per unit apparent volume of catalyst. The numbers in the first column refer to the notes appended to the table.

<sup>8</sup> B. P. 6,477/1914.

<sup>9</sup> This water-gas was obtained from a plant producing hydrogen by the liquefaction process. A low temperature water-gas is produced rich in hydrogen, low in carbon monoxide and relatively high in carbon dioxide. (See p. 91, Chap. IV.) The gas used in the experiments under consideration had been freed from its carbon dioxide content by pressure water washing and treatment with caustic soda solution. The main constituents were  $H_2 = 57\%$ ;  $CO = 38\%$ ;  $N_2 = 5\%$ .

<i>Catalyst No.</i>	<i>Constituents</i>	<i>Temperature</i>	<i>Space Velocity</i>	<i>%CO<sub>2</sub></i>	<i>%CO</i>
1	Fe-Cr oxides	450°	6500	24.8	1.6
1a	Fe-Cr oxides	450	7000	24.7	1.8
2	Fe-Cr-Th oxides	450	5000	25.0	1.2
2a	Fe-Cr-Th oxides	500	9000	25.2	1.0
3	Fe-Ni-Cr oxides	460	4000	25.0	1.2
4	Zn-Cr oxides	550	2500	8.8	10
5	Pb-Ur oxides	515	2000	24.8	1.7
6	Fe oxide (bog iron ore)	550	720	18.0	10
7	Haematite	580	1000	20.0	—
8	Fe oxide from Spathic ore	550	720	22.3	4
9	8 with Cr oxide	450	1600	24.3	2.3
10	Bauxite	450	660	2.5	30
11	Fe oxide ex sodium ferrite	510	1200	15.0	15
12	11 with Cu as couple	485	1200	23.0	3.0

## NOTES ON THE CATALYSTS

1. From 85 parts ferric nitrate and 15 parts chromium nitrate precipitated as hydroxide and ignited at 500° C.<sup>10</sup>

1a. As in 1, but prepared by ignition of nitrates in stream of air and steam at 500°.

2. From 195 parts ferric nitrate, 4 parts ammonium bichromate, 1 part thorium nitrate. Solution evaporated and residue ignited at 500°.<sup>11</sup>

2a. As in 2, H<sub>2</sub>O/H<sub>2</sub> ratio = 3 : 1.

3. From 40 parts ferric nitrate, 5 parts nickel nitrate, 5 parts chromium nitrate. Solution precipitated with potassium carbonate, precipitate washed, dried and ignited.<sup>12</sup>

4. Ignition of zinc oxide with twice its weight of chromium nitrate.

<sup>10</sup> Cf. B. P. 27,963/1913. U. S. P. 1,330,772/1920.

<sup>11</sup> Cf. B. P. 27,963/1913. U. S. P. 1,330,772/1920.

<sup>12</sup> Cf. B. P. 27,963/1913.



5. From 3 parts of lead nitrate with one of uranium nitrate.
6. From Dutch bog iron ore, calcined in air for 2 hours at 600°.
7. A coarsely powdered sample of massive haematite, heated initially to 600°.
8. From five ccs. of coarsely powdered spathic iron ore heated in a current of water gas until carbon dioxide evolution ceased.
9. The residue from 8, soaked in strong solution of chromium nitrate, dried and ignited.
10. A coarsely powdered sample of bauxite with moderate iron content.
11. Iron oxide from sodium ferrite.<sup>13</sup>
12. Iron oxide as in 11, reduced to metal, immersed in copper nitrate until some copper separated, then washed, dried and used.<sup>14</sup>

It is evident from such experiments that catalysts consisting in the main of iron oxide, preferably with other oxides as promoters will catalyse the water-gas reaction rapidly and efficiently, since the data given in respect to the first three catalysts represent approximately equilibrium conditions under the conditions of experiment chosen. The writer has employed for large scale trials iron-chromium oxide catalysts and iron-chromium-cerium oxide catalysts with complete success. They have been used with and without the use of binding agents. The velocities quoted above, however, are not realisable in large scale working. Available information seems to indicate that the Badische Co. employed iron-chromium oxide catalysts upon a porous support, although they have been credited with the use of a porous, spongy oxide obtained by reduction and oxidation of Swedish iron ore. It is probable that a space velocity not exceeding 500 is used in technical practice.

*Operational Details.*—Consideration may first be given to the ratio of steam to water-gas employed. Assuming an exit gas temperature of 550° and a catalytic agent capable of producing equilibrium at the velocity of gas flow employed, it is interesting

<sup>13</sup> Cf. B. P. 6,476/1914.

<sup>14</sup> Cf. B. P. 6,477/1914.

to calculate the results obtained with various steam-water-gas ratios. Let us assume, first of all, equal volumes of hydrogen and steam in the exit gases. Then, since the equilibrium constant is approximately 0.2,

$$K = 0.2 = \frac{P_{\text{CO}_2}}{P_{\text{H}_2}} \times \frac{P_{\text{H}_2\text{O}}}{P_{\text{CO}}} \text{ or } \frac{P_{\text{CO}_2}}{P_{\text{CO}}} = 0.2.$$

The carbon monoxide would be approximately one-fifth the percentage of the carbon dioxide. With a concentration of the latter equal to about 30 per cent it follows that the carbon monoxide would be about 6 per cent. In practice, this high residual concentration of carbon monoxide is not permissible and so resort is had to an excess of steam which by increasing the ratio  $P_{\text{H}_2\text{O}}/P_{\text{H}_2}$  decreases the ratio  $P_{\text{CO}}/P_{\text{CO}_2}$  correspondingly. Apparently an economic balance is set up between excess of steam required on the one hand and the quantity of carbon monoxide subsequently to be removed on the other hand. Endeavour is made to reduce the carbon monoxide of the residual gas (dry basis) to less than 3 per cent. From the equilibrium data this involves the use of approximately 3 volumes of steam to one volume of water-gas and, with a fresh active catalyst giving approximately equilibrium values, this ratio suffices. As the catalyst deteriorates with use, however, and the attainment of equilibrium conditions becomes less easy, extra steam is added to compensate for this loss of activity. It is probably economical to use a catalyst no longer than the period over which the requisite reduction of carbon monoxide concentration can be attained without using more than 5 volumes of steam to one of water-gas. For iron oxide catalysts of the type named a "life" of six months may be assumed. In the initial period of running, 3 volumes of steam per volume of water-gas will suffice, while towards the end, as much as five volumes will be in use. It should be observed, as perusal of the equilibrium equation shows, that elimination of carbon monoxide to negligible quantities could only be secured with prohibitive excesses of steam. Thus if 3 volumes of steam reduce the carbon monoxide content to 3 per cent at equilibrium, it will require 6 volumes of steam to reduce the percentage to 1.5 per cent, 12 volumes to reduce it to 0.75 per cent, and so on. Such

quantities of steam are economically impossible. Lowering the temperature at which the catalyst was active would assist somewhat in obviating the use of such quantities of steam by lowering the value of  $K$ .

As to steam and water-gas specifications the following points may be detailed. Low pressure steam is adequate for the process. A part of the requisite steam concentration may be obtained by passing the water-gas counter-current to a stream of hot water. Exhaust steam may also be used. Steam at a pressure sufficient to operate an injector for the water-gas has been employed in order to obtain an easily regulated mixture of the two constituents. The water-gas employed should be made from a well-coked coal as free as possible from undecomposed tar and hydrocarbon-yielding constituents. Unsaturated hydrocarbons retard the velocity of the reaction. Saturated hydrocarbons have no influence on the reaction velocity but represent inert constituents difficult to remove from the residual hydrogen. For the same reason, unless the hydrogen is to be used for ammonia synthesis, the nitrogen content of the water-gas should be maintained as low as possible, since it is impossible to remove this constituent in technical practice. In regard to other impurities, it is only necessary to remove mechanical impurities such as coke-dust, and this is effected generally by scrubbing in a mechanical scrubber. It is not necessary to remove hydrogen sulphide from the water-gas before use, since, in presence of the excess steam employed, the sulphide is not fixed by the iron oxide catalyst, but passes on unaffected and may be removed along with the carbon dioxide in a subsequent operation. Furthermore, the organic sulphur compounds present in the gas are catalytically converted during the process to hydrogen sulphide and carbon dioxide.

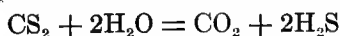

The effluent gases from the catalyst chamber are thus free from carbon sulphur compounds which, ordinarily, are difficult to remove and frequently are troublesome in the uses to which the hydrogen is put, as for example in catalytic hydrogenation processes.

The thermal effect of the reaction is approximately adequate to make the process self-sustaining. At ordinary temperatures the conversion involves the evolution of 10,500 calories:



and it may be calculated that, at a temperature of 500° the variation of the heat of reaction with temperature reduces this quantity to 9,650 calories. A simple calculation based on the specific heats and quantities of the incoming and outgoing gases serves to show that the heat of reaction is sufficient to raise the temperature of an average reaction mixture by about 70-100° C. Obviously the actual temperature rise will depend on the composition of the gas. If a high steam-water-gas ratio is used the temperature rise will be correspondingly low. Also, if a semi-water-gas is used in order finally to obtain a nitrogen-hydrogen mixture, the thermal capacity of the nitrogen content will also tend to diminish the temperature rise. Since the mean temperature interval through which the gases must be raised is about 450° C. it is apparent that a heat exchanger equipment capable of giving an 80 per cent heat regeneration with a temperature differential of approximately 100° C. between inside and outside gases would suffice to make the process self-sustaining. As the catalyst deteriorates in efficiency and as correspondingly more steam is used, the net increase in temperature, due to reaction, correspondingly diminishes. In such case, additional heat might be required. Provision should therefore be made to supply this heat from external sources. This can readily be done by using only the return tubes of a heat exchanger for the steam-water-gas mixture, maintaining the exchanger at the desired temperature by combustion of some fuel-gas on the other side of the tubes. The gases leaving the exchanger system cannot be sensibly lower than 90° C. in temperature, since, otherwise, considerable condensation of steam would occur in the system. This steam is removed by cooling in scrubber condensers. Recent improvements in the process have, however, been directed towards condensation of this steam and utilising the hot water thus obtained to saturate incoming gas with steam.

The removal of carbon dioxide and hydrogen is the operation immediately succeeding the condensation of steam. The gases are compressed to about 25-30 atms. and scrubbed, counter-current, with water under the same pressure. The pressure chosen represents a compromise between several factors, including compression costs (which vary approximately as the logarithm of the

pressure), solubility of the gas to be removed and of the other gases. In case the gas is to be used finally at higher pressures, it may be economical to conduct the water-scrubbing at these higher pressures. In good practice, a 30 per cent excess of water over that required according to the theoretical solubility data for carbon dioxide, is adequate to reduce the carbon dioxide concentration from circa 30 per cent to about 0.1-0.2 per cent. At the same time the hydrogen sulphide is reduced to negligible concentrations. It should be noted that at increased pressures the solubility does not increase at a rate corresponding closely to Henry's Law. The data of Wroblewski<sup>15</sup> show the following solubilities in ccs. per cc. of water at 12.4° C.

Pressure in Atms.	1	5	10	15	20
Solubility	1.086	5.15	9.65	13.63	17.11

Losses of hydrogen in the process of water washing are also marked, actual practice showing a loss of as much as twice the theoretical loss of 5 per cent.

Modification of the procedure here outlined may be introduced in case the hydrogen is required for purposes of ammonia synthesis. The alternative methods of operation aim at the production of a nitrogen-hydrogen mixture approaching that required in the synthetic process,  $N_2 : H_2 = 1 : 3$ . This end may be achieved in several ways. Thus, for example, the water-gas used may be modified by introduction of air into the generator during the steaming phase, in such a proportion that the ratio of nitrogen to hydrogen or hydrogen-equivalent gas (CO) will, at the conclusion of the operations, yield a nitrogen-hydrogen mixture of the necessary volume relations. The same modification may be brought about by utilising a portion of the "blow" gases from the water-gas generator along with the water-gas from the "run," or steaming phase. By another alternative, the necessary nitrogen may be supplied in the form of ordinary producer gas. Finally it is possible to introduce the nitrogen as air in the catalytic reaction. In this case, a high thermal effect results and care must be exercised that the temperature elevation does not become unduly high, as, thereby, the conversion efficiency would be lowered, owing to the unfavorable equilibrium conditions in the water-gas reaction at higher temperatures. Attention should be directed to the fact that, by introducing nitrogen in these several ways, inert

<sup>15</sup> *Compt. rend.*, 1882, 94, 1,355.

constituents in the form of the rare gases, argon and its associated elements are introduced into the gas mixture. These gases accumulate in a circulatory system of utilisation and, with methane also present, compel the adoption of a system of "blowing off," whereby a certain fraction of the nitrogen-hydrogen mixture must be continuously lost in keeping the inert constituents below a permissible maximum concentration in the operation of ammonia synthesis.

*Gas Composition Flow Sheets.*—The several stages which have just been discussed in respect to operational details may readily be comprehended from the appended tables giving gas volume and gas percentage flow sheets for a typical operation involving an average blue water-gas and steam as reacting materials. Assumption is made that the equilibrium conditions are such that after leaving the catalyst chamber the gases contain 2 per cent by volume of carbon monoxide, calculated on the dry gas basis.

GAS VOLUME FLOW SHEET

<i>Stage of Operation</i>	$H_2$	$N_2$	$CH_4$	$CO$	$CO_2$	$H_2O$	<i>Total</i>
Water-gas .....	47.1	3.6	0.4	42.7	3.2	3.0	100.0
Steam added .....	47.1	3.6	0.4	42.7	3.2	303.0	400.0
At catalyst exit .....	87.0	3.6	0.4	2.8	43.1	263.1	400.0
After condenser .....	87.0	3.6	0.4	2.8	43.1	4.3	141.2
After compressor (30 atms.) .....	87.0	3.6	0.4	2.8	43.1	0.14	137.0
After carbon dioxide scrubber .....	80.3	3.25	0.4	2.5	0.2	0.1	86.7

GAS PERCENTAGE FLOW SHEET

<i>Stage of Operation</i>	$H_2$	$N_2$	$CH_4$	$CO$	$CO_2$	$H_2O$	<i>Total %</i>
Water-gas .....	47.1	3.6	0.4	42.7	3.2	3.0	100
Steam added .....	11.8	0.9	0.1	10.7	0.8	75.7	100
At catalyst exit .....	21.7	0.9	0.1	0.7	10.8	65.8	100
After condenser .....	61.7	2.5	0.3	1.9	30.6	3.0	100
After compressor (30 atms.) .....	63.5	2.6	0.3	2.0	31.5	0.1	100
After carbon dioxide scrubber .....	92.6	3.75	0.45	2.9	0.25	0.1	100

From the gas volume flow sheet it is apparent that the capacity of the catalyst unit, exchanger and condenser system must be quadruple the capacity of the plant generating water-gas, owing to the excess of steam added. It will be noted that the carbon dioxide scrubber also effects the removal of some of the other gases, losses in this respect being both mechanical and due to solution. Only in the case of hydrogen is the loss serious, and here it approximates to 10 per cent of the useful product desired. It will be noted that this loss accounts mainly for the diminution in gas volume by conduct of the process. Thus, from 100 volumes of water gas only 86.7 volumes of the product result containing 80.3 volumes of hydrogen. This would be diminished to 84.2 volumes of total gas were the carbon monoxide eliminated. Nevertheless, it is obvious that not more than  $100/80.3 = 1.25$  volumes of water-gas are required in this process to produce one volume of hydrogen in the product indicated as to purity by the last line in the gas percentage flow sheet. This is one of the main reasons for the economy of the process as contrasted with those methods previously discussed.

Comparison of the resulting gas mixture with the product from the liquefaction process, Chapter IV, shows a similar concentration of carbon monoxide but a higher concentration of both nitrogen and methane. The former of these two gases cannot readily be removed and so should be diminished in the original water-gas if a low concentration of impurities is desired. According to some authorities, the methane concentration is altered in the water-gas catalysis by operation of one or other of the equilibria:

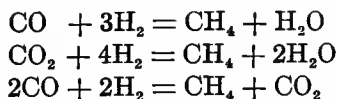

It is asserted that, from an original gas containing no methane, or from one with as much as 10 per cent methane, the issuing gas from the catalyst contains approximately 0.5 per cent of this gas reckoned on the dry basis, free from carbon dioxide. Confirmation of this point would be of great importance, since it would enable the use of cheaper starting raw material than water-gas, for example, coke oven gas or producer gas. Preliminary experiments by the writer have failed to confirm this view but the mat-

ter is deserving of the closest investigation. It may be said, in support of the claim, that calculations on these three equilibria, using the Nernst approximation formula, indicate methane concentrations of the order claimed, at 500° C.

*Plant Details.*—A diagrammatic flow sheet of the process as outlined in the gas composition flow sheet is given in the accompanying diagram, Fig. VI. The items of this system which call for special treatment may now be discussed.

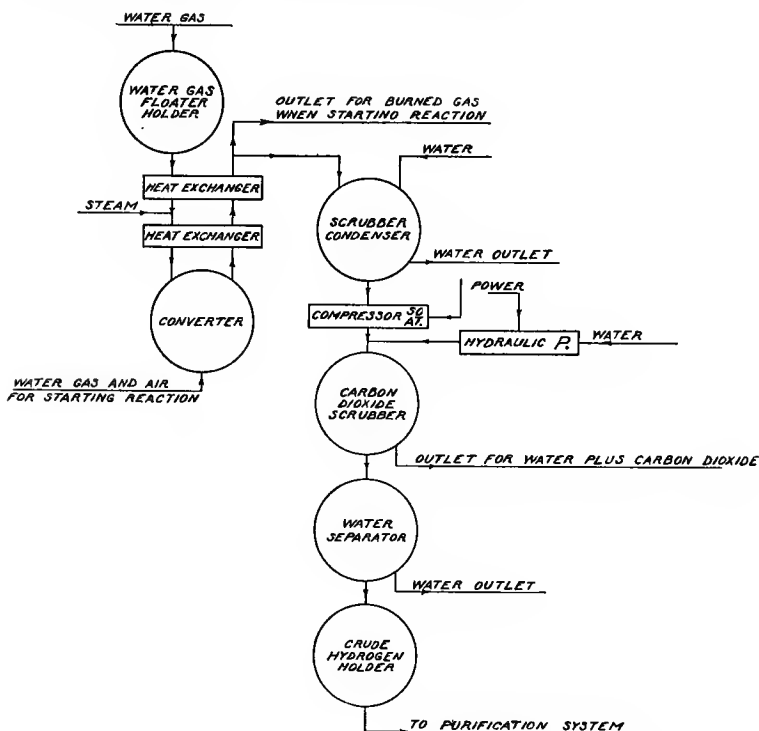

FIG. VI. Diagrammatic Flow-Sheet of Continuous Water-Gas Catalytic Process.

(a) *The Catalyst Unit.*—This consists essentially of an iron box to hold the catalyst material and devised to ensure an even distribution of the reacting gases and suitable thermal equilibrium. The original technical units of the Badische Co. had a capacity of 25,000 cubic feet of water-gas per hour but the later installations were capable of receiving up to 35,000 cubic feet per hour. The apparent volume of catalyst required for this



latter output should not be more than 75 cubic feet with a catalyst of average efficiency. The mode of distribution of the catalyst varies in different plants. In one form the catalyst is contained in a single circular bed the diameter of which is much greater than the depth. Apparently the Badische Co. adopted a tray form of converter similar to the familiar Grillo contact sulphuric acid process converter. The catalyst is distributed on a succession of trays separated from each other by gas spaces. The advantages of this type are several. A friable catalyst may be used, since the weight the bottom layers have to support is minimized when the material is divided into several portions. Furthermore, "hot-spots" and "short-circuits" in the catalyst bed are less serious in the tray form of converter, since, between each tray, the gas molecules have opportunity to come to temperature equilibrium before undergoing further conversion in the succeeding tray. Trays facilitate the work of charging and discharging and they render possible arrangements whereby the reacting gas, for example, in this case the steam, may be added in several stages, enabling thereby a closer thermal control of the process. Thus, it is possible to conceive of the present operation being conducted in two units. In the first the major portion of the conversion would be accomplished. A further addition of steam at this stage would cool the reacting gases down to a temperature low enough to enable a lower concentration of carbon monoxide to be reached in the second unit of the converter. With a multiple unit converter a varied sequence of units could be obtained so arranged that the last stages of the conversion were always effected by the most active catalyst. Since heat must be conserved if the process is to be thermally self-sustaining, the units should all be heavily lagged with inside protection also, against heat loss, if possible. Fig. VII<sup>16</sup> represents diagrammatically such a scheme, with multiple heat exchange.

(b) *Heat Interchangers.*—The design of the heat exchange plant is of great importance since the full economy of the process rests on the self sustaining feature of the process in regard to heat and since, also, the cost of the necessary equipment is a considerable fraction of total plant cost. It will be useful therefore to emphasize some of the factors to be observed in inter-

<sup>16</sup> Courtesy of *Chemical and Metallurgical Engineering: Description of Synthetic Ammonia plant, Oppau, Germany, 1921, 24, 391.*

changer design. The rate of transfer is relatively independent of the thermal conductivity of the metal tube across which heat is being carried. Transfer is poor if the gas be flowing with streamline motion since it can only occur by conduction from layer to

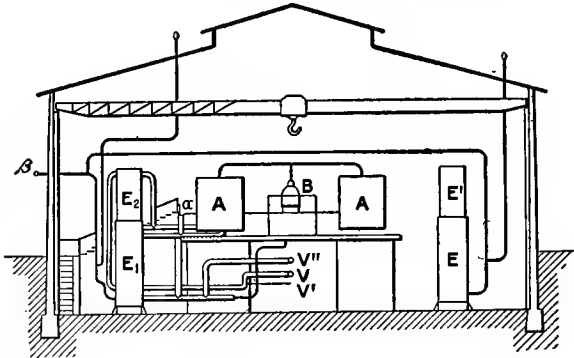

FIG. VIIA.

layer of the poorly conducting gas. Furthermore, the stationary layer of gas on the walls of the tube offers a comparatively high thermal resistance. If the gas flow exceeded the critical velocity and the motion be turbulent, transfer of heat is much more ef-

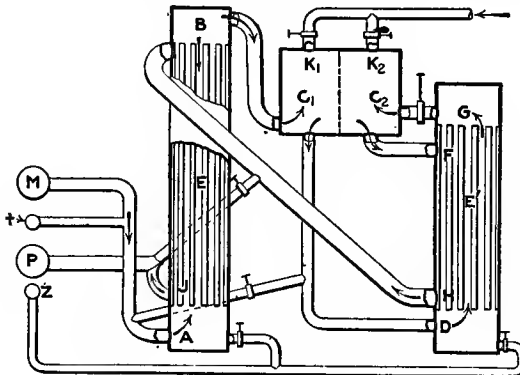

FIG. VIIB.

ficient. Also, the faster the linear velocity of flow the thinner is the stagnant layer of gas and so, the better the heat transfer. The heat transfer in calories per unit area per degree temperature difference per hour may be designated as the coefficient of heat

transfer. This coefficient is dependent also on the diameter of the tube, falling off slowly with increase in diameter.

The economical size of a heat interchanger unit has yet to be determined. For the catalyst chamber of 35,000 cubic feet capacity adopted by the Badische Co. the writer would suggest that a unit containing not less than 1,000 square feet of interchanger surface would be a suitable unit. From some available small scale data it would seem that at least five such units would be necessary for the total capacity of 35,000 cubic feet per hour. The size of tube in the interchanger and their distribution would be set by the linear velocity of gas flow. This should be such that a linear velocity of flow of not less than 30 feet per second should be attained in the coolest portion of the heat interchanger system. The volume of gas space inside and outside the interchanger tubes should be approximately the same, a slightly larger volume being permissible, however, on the side taken by the return gases, since these are at the higher temperature.

*Condensers.*—These are usually of the scrubber type with water flowing over coke or some similar baffling material, counter current to the gas to be freed from steam. A tubular type of condenser is, however, applicable, in which case the condensed water may be used as feed water for the boiler unit or to supply to the incoming water-gas a portion of its steam requirements. The hot water from the scrubber condensers may also be used for this purpose.

*Gas Compressor.*—For compression of the gas to 25-30 atmospheres, double line three stage compressors have been found to be eminently suitable.

*Water Compressor.*—This is usually a simple hydraulic pump delivering water against the given pressure of 25-30 atmospheres. It may be driven from a motor or the power requisite may be supplied in part from a Pelton wheel operated by means of the exit water from the pressure water scrubbers and in part from an auxiliary motor. Special attention must be paid in the case of the Pelton wheel to the question of attack from the water leaving the scrubbers, since, owing to the high concentration of dissolved carbon dioxide, the water has a vigorous corroding effect on iron.

*Scrubbers for Pressure Water Washing.*—These are built of cast steel in order to withstand the prevailing pressure. In the Badische plant the scrubbers are tall narrow towers approximately 1 meter diameter by 12 meters high, closely packed with Raschig rings or similar packing material. A better water distribution is obtained with this tall type of scrubber. Low efficiency was attained in one plant where this system of carbon dioxide removal was in use with a scrubber in which the ratio of height to diameter was only 4 : 1. Earthenware packing is preferable to iron packing, since the latter is attacked by the carbonated water produced in the process. The size of the tower should be such that a time of contact between compressed gas and water in a well-packed tower should be about 15 minutes at a working pressure of 25 atmospheres; at higher pressures, less time will suffice.

*Further Purification of the Exit Gases.*—Reference to the gas composition flow sheets will show that the main impurities are carbon monoxide (2-3%), nitrogen (3-4%) and methane (0-1%), with small quantities of carbon dioxide and traces of sulphuretted hydrogen. The two last may be completely removed by scrubbing with alkalis or passage over lime. In the case of nitrogen and methane, which are present in the incoming water-gas, no satisfactory methods of removing the same have been developed technically. The elimination of such gases is a problem to be attacked in the original water-gas production.<sup>17</sup> A variety of methods are possible for the elimination of carbon monoxide. These are so varied and so important that they will receive special treatment in a later chapter.

#### *The Griesheim-Elektron Process.*

*Outline of the Process.*—Water-gas and steam are admixed, raised to a temperature of approximately 450°, and passed over lime in presence or absence of suitable activators. The water-gas reaction is brought about, carbon dioxide is absorbed by the lime and a gas mixture, consisting essentially of hydrogen, traces of carbon monoxide, excess of steam together with the nitrogen and methane content of the original water-gas, issues from the reaction chamber. The residual gas is freed from steam and may

<sup>17</sup> See, in this connection, Harger, *Chemical Age* (London), 1919, 1.

then be utilised as such or submitted to further purification processes.

*Literature Résumé.*—A patent to the French inventor, Tessie du Motay <sup>18</sup> claims the production of hydrogen by passing steam and water-gas, freed from sulphur, over heated lime. The removal of sulphur is quite unnecessary as lime absorbs hydrogen sulphide and catalytically converts carbon disulphide in presence of steam to hydrogen sulphide and carbon dioxide both of which are fixed by lime.

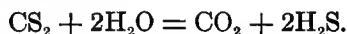

The patent claims of the Griesheim-Elektron Co., (B. P. 2523/1909; Ellenberger, U. S. P. 989,955) amplify the original claim of du Motay in that, by addition to the lime, either slaked or caustic, of 5 per cent by weight of iron powder, which, however, would certainly be converted during the process to iron oxide, the reaction may be greatly accelerated. The patent claims point out that the reaction is exothermic so that, not only is the process thermally self-sustaining, but that cooling is required in order to keep the temperature of the reaction mass at or below 500° C. The thermal data relative to the reactions are given in the two equations:

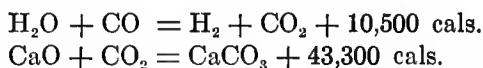

A suitable method of conducting the process is outlined in B. P. 13,049/1912, in which vertical towers containing lime in the form of lumps are suggested. It is pointed out that the reaction is not confined to the surface but penetrates to the interior of the material. Furthermore, it is claimed that, with lumps of lime in vertical towers, regeneration of spent material may be effected *in situ*. The resistance of the material to such an alternation of reactions will at once be seen to be of importance. In actual practice, it has been found that the tendency to disintegration is very great and that the lumps of lime rapidly change to a powder, this factor constituting an important disadvantage in the process. A patent to Siedler and Henke <sup>19</sup> covers this same use of a tower of lime, the interval of temperature recorded being

<sup>18</sup> U. S. P. 229,339/1880.

<sup>19</sup> U. S. P. 1,181,264.

<sup>20</sup> U. S. P. 1,173,417.

400°-750° C. A patent to Ellis<sup>20</sup> covers the same ground as far as the essentials of the process are concerned. As regards mode of conduct of the process, Ellis would operate with chute conveyors sending the lime downwards through the reaction system counter-current to an ascending supply of gas and steam. As specification for the lime, it is suggested that a limestone low in magnesia should be employed. For activation, both iron and manganese oxides are specified and special directions as to the preparation of these oxides are included.

*Mechanism of the Reaction.*—The reaction has been the subject of extended experimental investigation. Merz and Weith<sup>21</sup> showed that carbon monoxide when passed over calcium hydroxide yielded hydrogen with only a small content of carbon monoxide at reaction temperatures below visible redness. Engels<sup>22</sup> investigated fully the influence of temperature, steam concentration, catalyst additions and velocity of gas flow in the same reaction. According to Engels, the reactions in presence and absence of a catalyst are different. When catalysts are absent, the reaction is essentially a solid-gas reaction in which the reacting materials are calcium hydroxide and carbon monoxide.

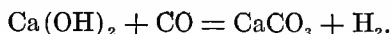

The later researches of Levi and Piva<sup>23</sup> indicate that this reaction proceeds through the intermediate stages of formate and oxalate. In support of this, the interaction of sodium formate and carbon monoxide to form hydrogen and carbon dioxide is instanced. Subsequent investigations by the same authors<sup>24</sup> led to the conclusion that slaked lime could take part in the sodium formate reaction to the extent of lowering the decomposition temperature from 375° C. to 260° C. Experiments of the writer have shown that decomposition of pure sodium formate occurs with low velocity at 260° C., so that the influence of the lime is probably to accelerate the velocity of decomposition. Carbon monoxide and pure lime interact below 300° C. to give formate. Above this temperature calcium carbonate and hydrogen are produced. To a small and very minor extent, the water-

<sup>21</sup> *Ber.*, 1880, 13, 718.

<sup>22</sup> Dissertation, Karlsruhe 1911. *J. Gasbeleucht.* 1919, 62, 477 and 493.

<sup>23</sup> *J. Soc. Chem. Ind.* 1914, 33, 310.

<sup>24</sup> *J. Chem. Soc.*, Abstracts 1916, 110, ff. 525.

gas reaction between steam and carbon monoxide also takes place when pure lime alone is present.

In presence of a catalyst, however, such as iron oxide, Engels points out that the reaction is quite different. The main process is then the gas reaction

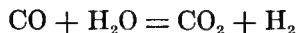

in contact with the iron oxide. The slower reaction of carbon monoxide with calcium hydroxide undoubtedly occurs, but it is negligible in effect when compared with the catalysed gas reaction. The relative rapidities of the two reactions are shown by the following data with regard to a carbon monoxide—steam mixture containing 19 per cent of the former, at a working temperature of 500° C., the gas velocity being measured at 20° C. and referred to 1 litre of contact agent.

<i>Contact agent</i>	<i>Velocity of CO in litres per hour per litre of contact agent</i>	<i>CO con- centration in exit gas</i>
Calcium hydroxide	12.5	0.4%
Calcium hydroxide 5% iron	138	0.2%

The reaction velocity is increased tenfold by iron oxide with the given gas mixture. The steam concentration is also a factor of importance. In the reaction with pure calcium hydroxide a concentration of steam greater than that necessary to maintain the lime in the hydroxide state merely acts as a diluent. Also, since the hydroxide is the active agent and since, at 547° C., the decomposition pressure of the hydroxide becomes one atmosphere it is not advisable to work at higher temperatures than 547° C. With iron oxide present and the water-gas reaction predominating, it follows from the considerations advanced in the preceding discussion of the continuous catalytic process that excess of steam is favorable to diminution of the carbon monoxide content. The temperature too may be as high as is consistent with the use of lime as absorption agent for the carbon dioxide produced in the water-gas reaction.

These observations as to mechanism give point to the recent proposal embodied in the patent to Greenwood (B. P. 137,340/

1918). According to this patent, the production of hydrogen from water-gas and steam may be effected by first leading the water-gas-steam mixture over iron oxide or preferably an active catalyst of the type previously detailed (e. g., iron-chromium oxides) to establish the water-gas equilibrium. By passage through a lime tower at the same temperature the carbon dioxide present would then be removed as far as the equilibrium concentration of the gas in presence of lime at the given temperature would permit. A further passage of the residual gas over another iron contact mass could then be undertaken, with a correspondingly further diminution in the carbon monoxide concentration. The gases could then be cooled, the excess steam condensed and the carbon dioxide eliminated by any suitable means. This is, therefore, a proposal to separate the two reactions, the water-gas reaction and carbon dioxide absorption which occur simultaneously in the process of the Griesheim-Elektron Co. and to make of them successive reactions which could be repeated if necessary. With a separated catalyst and absorption agent a more efficient promotion of the water-gas reaction can be achieved with the more active forms of catalyst, the activity of which is subject to diminution when submitted to the high temperatures necessary for regeneration of the spent lime. Experimental test of this view, undertaken by the author at the suggestion of Greenwood, fully confirmed its accuracy. Lower final concentrations of carbon monoxide were obtained with successive layers of catalyst, lime and catalyst (Fe-Cr oxides) than with a mixture of lime with five per cent of iron oxide. Considerably higher velocities of gas passage were attainable for the same purity of product.

*Operating Details.*—In the main, the considerations obtained in the continuous water-gas catalytic process are applicable in this process also, so that extended discussion is not necessary. It should be observed however that, as the total heat of reaction is in this case increased by the heat of combination of carbon dioxide and lime, the net heat effect of the reaction is strongly exothermic.



It would therefore be necessary to operate a cooling system with the process in order that the exit gas temperature should be suf-



ficiently low to favor low carbon monoxide concentration. The suggestion has been made that this cooling should be effected by means of water tube coolers and that the water so heated be utilised to raise steam for the process.

The additional factor of importance in the process is the saturation capacity of the lime for carbon dioxide. Experiment has shown that with the lime in the form of a coarse powder half the theoretical capacity of the lime for carbon dioxide may be utilised at 500° C. without sensible increase in the carbon monoxide content of the issuing gas. On this basis it can readily be calculated that for a gas such as is treated in the pressure water scrubbers of the continuous catalytic process (see p. 74) the quantity of lime needed per 1,000 cubic feet of hydrogen produced is of the order of 100 lbs. It is probably this factor of high lime consumption and the disintegration of the lime with repeated calcination, which constitute the main disadvantages of the process and militate against large technical operation. No case of large scale use of the process can as yet be recorded. The above data show that with a unit producing 35,000 cubic feet of hydrogen per hour a supplementary lime burning plant of 42 tons capacity per day would be required. For purposes of ammonia synthesis it is doubtful whether even the gas thus produced would be sufficiently free from carbon monoxide without additional purification. The stated purity of the gas product is

Hydrogen .....	95.5-97.5
Carbon monoxide .....	0.0- 0.2
Methane .....	0.3- 0.5
Nitrogen .....	2.0- 4.0

The discontinuity of the process involved in the alternate absorption of carbon dioxide by lime and subsequent calcination of calcium carbonate doubtless means high labor charges as contrasted with the continuity of the pressure-water-washing process followed in the continuous water-gas catalytic process. Mechanical troubles in the distribution of the lime, in a form suitable for absorption, might also be anticipated. Offsetting these difficulties, the operation may be conducted at atmospheric pressures but, for hydrogen for ammonia synthesis, compression of the gas would ultimately be necessary.

It is possible that the process might find application in the

removal of residual carbon monoxide from gases produced by other methods. With small carbon monoxide concentrations the technique of the process should be very much simpler.

*Dieffenbach and Moldenhauer Process.*

*Outline of the Process.*—Water-gas is produced, the water-gas reaction is effected and, in some proposed modifications of the process, the carbon dioxide formed is absorbed, in a one-stage process, by the passage of steam through a bed of fuel impregnated or intermixed with materials which tend to lower the temperature of interaction of carbon and steam. In this way it is proposed to carry out in a single operation the several reactions which are involved in the two preceding processes of hydrogen production. The net reaction would therefore be:

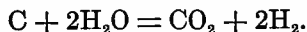

Thus far, no technical application of the process has been recorded nor does there appear to be any immediate prospect of such application.

*Literature Résumé.*—An old patent to Tessie du Motay and Maréchal<sup>25</sup> calls for the production of hydrogen and carbon dioxide by heating fuel with lime or caustic soda. Anticipating the claims of Dieffenbach and Moldenhauer are the proposals of Krupp<sup>26</sup> in which steam is caused to interact with fuels impregnated with hydrates or carbonates. The carbon monoxide concentration is thereby suppressed and any carbon dioxide produced may be removed by passing over heated lime. In a series of patents<sup>27</sup> various materials are suggested by Dieffenbach and Moldenhauer to lower the temperature of interaction of steam and carbon. Coke impregnated or admixed with chlorides, sulphates or sulphides is said to be sufficiently reactive at 600° C. Substituting a silicate as added material a temperature interval of 550°-750° C. is covered. The last patent of the series advocates the production of the reaction material by pulverising the materials, grinding to intimate admixture and briquetting the powdered product. Operating at the low temperatures stated a carbon monoxide concentration not exceeding a few tenths of one

<sup>25</sup> B. P. 2,548/1867.

<sup>26</sup> B. P. 8,426/1892.

<sup>27</sup> B. P. 7,718, 7,719, 7,720/1910.

per cent is the extent of this impurity recorded as present in the resulting gas. A later patent<sup>28</sup> advocates the use of lime in addition to the catalytic agent to act as absorbent for the carbon dioxide produced and consequently to lower also the carbon monoxide concentration. As an example of such procedure the use of coke, with an impregnation from a 10 per cent potassium carbonate solution and admixture with five times its weight of lime, is cited, the reaction temperature being quoted as 550°-750° C. The Griesheim-Elektron Co.<sup>29</sup> adapt this idea to a process operating under a pressure of 10 atmospheres with charcoal or lignite as source of carbon and lime or baryta as activator. With the former, a region of temperature between 600° and 800° C. is suggested. With the more expensive baryta lower temperatures are possible. The reaction may be conducted, as is the generation of water-gas, with an alternate air blow and steam run. The net thermal effect is still strongly positive, in spite of the endothermic nature of the reaction between carbon and steam, owing to the heat of formation of calcium carbonate.

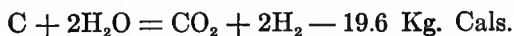

The steam run should therefore be proportionately much longer in this case than in the case of water-gas production.

A patent obtained by Prins<sup>30</sup> specifies other catalytic agents for the same reaction. Two or more catalytic agents are to be employed, one or more from each of the two following groups  
 (a) oxygen containing salts of the alkali or alkaline earth metals  
 (b) inorganic oxides or hydroxides which behave as non-volatile weak acids or acid anhydrides, as, for example,  $B_2O_3$ ,  $Al_2O_3$ ,  $Al_2C_3$ . Oxides of iron, chromium and manganese may also be incorporated. These, doubtless, are intended to promote the water-gas reaction as in the two processes previously discussed. The specified temperature interval is between 300° and 600° C. As an example of a mixture operative at 400°-500° C. the following is cited:  $Ca_3(PO_4)_2$ , 1 part; Sand, 2 parts; Coke, 20 parts.

*General Discussion.*—No experimental data can, as yet, be cited to illustrate the efficiency of such processes or the possi-

<sup>28</sup> B. P. 8,734/1910.

<sup>29</sup> D. R. P. 284,816/1914.

<sup>30</sup> B. P. 128,273/1917.

bilities inherent in such for technical application. The test of their practicability will lie largely in a determination of the attainable minimum of carbon monoxide concentration under technically feasible conditions. The processes would be of little value as alternatives to the two preceding processes unless the concentration of carbon monoxide obtained was equal to or less than two per cent, since, if such a concentration were exceeded, new and, doubtless, expensive methods of carbon monoxide removal would be necessary.

The reactivity of the carbon is certainly a function of the nature of the carbonaceous material employed as well as of the catalytic agents added. Hence, it is possible that certain types of carbon might find application where coke would be of little use. The problem of availability of such fuels would then become important.

Given a technically feasible reaction process, the plant required would be comparatively simple and inexpensive consisting mainly of a generator and of the apparatus necessary for the preparation of the reaction material in suitable form. Pulverisers, mixers and briquetting machines would seem to be indicated.

The gas, after production, would require removal of carbon dioxide and then of carbon monoxide. It is unlikely that sufficient lime could be incorporated in the reaction mixture to absorb all the carbon dioxide produced whilst still retaining the necessary cheapness of materials used.

Experiments conducted by H. A. Neville under the direction of the writer have yielded results of considerable interest from the standpoint of mechanism in such a one-stage process. The catalytic effect of alkali carbonates has been shown to be very much more pronounced than that of any of the other contact agents named in the literature résumé. Good water-gas reaction catalysts, such as iron oxide, have little or no effect in speeding up the interaction of steam with charcoal. On the other hand, the catalysts found for such reaction with steam are identical in nature and effect with catalysts for the interaction of carbon dioxide and carbon. Furthermore, experiment has revealed that carbon in presence of potassium and other alkali carbonates adsorbs much larger quantities of carbon dioxide, at a temperature of 445° C., than does the same carbon in absence of the alkali carbonate, although this latter shows no specific adsorptive

capacity for carbon dioxide. The reactions occurring in this process are therefore, in all probability, to be ascribed to a succession of reactions

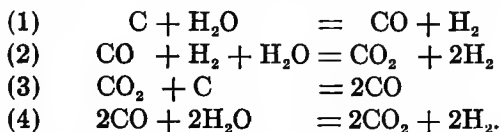

The catalyst apparently performs two functions: (a) it cleans the the surface of the carbon from fixed-oxygen complexes<sup>21</sup> so making the carbon more reactive; (b) it catalyses reaction (3) above and so increases the yield of carbon monoxide which is then transformed by reaction (4) into carbon dioxide and hydrogen. A full discussion of this problem will form the subject of an early publication in the chemical literature.

<sup>21</sup> See Lowry and Hulett. *J. Am. Chem. Soc.* 1920, 42, 1,408.

## Chapter IV.

### Hydrogen From Water-Gas.

For purposes of ammonia synthesis and for hydrogenation processes, hydrogen has been produced technically by the successive removal of the various other gaseous constituents of water-gas. Of the operations involved, the removal of the carbon monoxide is the most important and this has been accomplished by the physical method of liquefaction. The divergence between the boiling points of hydrogen and carbon monoxide coupled with the facilities now obtaining for the attainment of the low temperatures requisite, render such a process technically feasible.

The sequence of operations, in outline, is as follows. Water-gas as produced is freed from dust and steam by an efficient scrubbing process. Hydrogen sulphide is then removed by iron oxide box treatment or by other suitable means. (See p. 42.) The gas is next compressed and freed from carbon dioxide and traces of sulphuretted hydrogen by washing first with water under pressure and then with sodium hydroxide solutions. Water vapor is next removed by refrigeration in an ammonia refrigerator system. Thus freed from the principal minor impurities, the water-gas, still under pressure, passes to the liquefaction system in which the bulk of the carbon monoxide and nitrogen together with minimal quantities of carbon-sulphur compounds and phosphorus compounds are separated in the liquefaction process. The uncondensed hydrogen passes away with small amounts of uncondensed nitrogen, methane and carbon monoxide. The carbon monoxide may, if so desired, be removed in subsequent processes of chemical treatment.

This sequence is indicated tabularly in the following gas volume flow sheet of the typical changes from water-gas to the hydrogen issuing from the liquefaction plant, the operations being conducted with the gases at 20 atmospheres pressure.

An approximate idea of the possibilities of the liquefaction

<i>Operation</i>	$H_2$	$CO$	$CO_2$	$H_2O$	$H_2S$	$N_2$ , <i>etc.</i>	<i>Total</i>
Water-Gas .....	52	34	6.6	3	0.4	4	100
Iron oxide box treatment to remove $H_2S$	52	34	6.6	3	...	4	99.6
Compression to 20 atmospheres .....	52	34	6.6	0.15	...	4	96.75
Pressure Water Washing .....	47	31	0.1-0.5	0.13	...	3.7	82.13
Pressure Caustic Scrubbing .....	47	31	....	0.13	...	3.7	81.83
Ammonia Refrigeration at $-35^\circ C.$ ...	47	31	....	....	...	3.7	81.7
Liquefaction at $-205^\circ C.$ .....							
(a) Uncondensed hydrogen fraction ....	40	0.75	....	....	...	0.35	41.1
(b) Liquid fraction ..	7	30.25	....	....	...	3.35	40.6

process as regards removal of carbon monoxide and nitrogen may be gained from an examination of the accompanying diagram (Fig. VIII) of the vapor pressures of liquid carbon monoxide and nitrogen at temperatures in the neighbourhood of their boiling points.<sup>1</sup> It may be seen, however, by comparison of the typical analysis of the uncondensed hydrogen fraction just given, with the simple data of the diagram, that the latter are not adequate in themselves to enable an exact forecast to be made of the percentages of carbon monoxide and nitrogen present in the hydrogen fraction. For, from the data in the figure, the nitrogen vapor pressure in equilibrium at a given temperature is always greater than that of the carbon monoxide, whereas, in the hydrogen gas obtained in practice, the nitrogen percentage is never much greater than one third of the total impurity. A complete knowledge of maximum attainable separations at various temperatures could not be obtained without a special study of the gas-liquid phase relationships of various mixtures of nitrogen and carbon monoxide. Furthermore, the efficiency of

<sup>1</sup> Nitrogen by Flischer and Alt cited from Abegg. Vol. III. 3. Carbon monoxide data by Baly and Donnan. *J. Chem. Soc.* 1902, 18, 919.

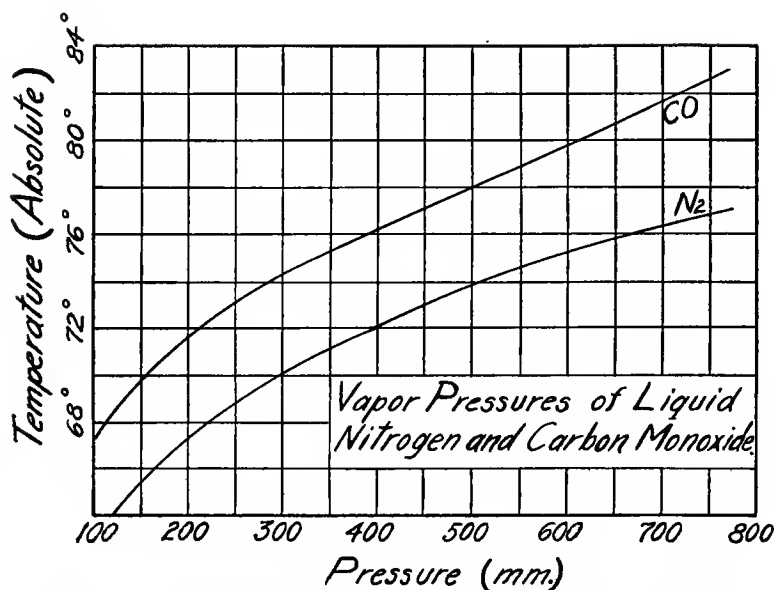

FIG. VIII. Vapor Pressures of Liquid Nitrogen and Carbon Monoxide.

separation of the condensed mists of carbon monoxide and nitrogen determine in part the final concentrations of these gases in the hydrogen obtained. The problem has a further complicating factor in the solubility of hydrogen in the liquid mixture. It can however be concluded from the diagram that to get a satisfactory removal of nitrogen and carbon monoxide the attainment of temperatures below 73° Abs. is essential. The technical methods by which this is accomplished differentiate the processes which thus far have been proposed.

*The Linde-Frank-Caro Process.*—This process was operated by the Badische Co. at Oppau in three units, each of a capacity of 35,000 cubic feet of hydrogen per hour, as the source of hydrogen for ammonia synthesis in the earliest stages of the technical development of the Haber process. A unit of 17,000 cubic feet of hydrogen per hour is in use at Selby, Yorkshire, England, by Messrs. Ardol, Ltd., for purposes of hydrogen supply for the hydrogenation of oils. Similar plants are in operation in Europe. So far as is known, this process has not been attempted on a technical scale for hydrogen production in this country.



The essential features of the process are covered by U. S. Patents 727,650; 728,173; 1,020,102; 1,020,103; 1,027,862; 1,027,863. As actually operated, the liquefaction process is conducted in three stages. The purified water-gas, freed from hydrogen sulphide, carbon dioxide and water vapor in the manner already indicated in outline, leaves the ammonia refrigeration system at  $-35^{\circ}$  C. It is next cooled by heat exchange with the uncondensed hydrogen fraction leaving the liquefaction system. Ordinarily, this hydrogen is still at the working pressure, in the average case, 20 atmospheres. An additional cooling effect could be obtained by allowing the hydrogen to expand to atmospheric pressure either with or without the performance of external work before entering the interchanger, but this is not done in technical operation of the Linde system, because of the advantage, in the subsequent utilisation, of having a compressed gas. The entering water-gas, cooled by interchange with hydrogen is next partially liquefied in a secondary cooler, composed of coils, on the outside of which carbon monoxide-rich liquid is allowed to vaporise at atmospheric pressure. The latent heat of vaporisation of the liquid is withdrawn from the entering gases and partial liquefaction is thus attained. Finally, the residual gas mixture is freed as far as practicable from carbon monoxide and nitrogen still present in the gas by passage through an auxiliary cooler of liquid air, boiling under a reduced pressure of several millimetres, the lowest practicable temperature being thus secured. The two fractions are separated; the hydrogen fraction passes to the primary heat exchanger, the pressure on the carbon monoxide-nitrogen liquid is released and the liquid mixture is driven over to the secondary cooler for vaporisation. This method of procedure is illustrated diagrammatically in the accompanying figure. (Fig. IX.)

A variety of modifications of such practice have been suggested, more especially with a view to obviating the use of liquid air as additional cooling agent. Where the hydrogen is required for ammonia synthesis it is obvious that the use of liquid air simultaneously offers a source of nitrogen, since, all that is required in addition, is a suitable fractionation column, to separate the oxygen and nitrogen.

By allowing the hydrogen leaving the chamber, in which separation of carbon monoxide has occurred, to expand, with per-

formance of external work, an additional cooling effect may be secured with further separation of carbon monoxide. It will be seen that this observation of Linde is a special feature of the Claude (Soc. L'Air Liquide) process to be described in detail later. Humboldt<sup>2</sup> allows the hydrogen-rich fraction simply to expand to normal pressure, additional carbon monoxide is deposited and the hydrogen passes on to the preliminary heat exchanger to cool the incoming water gas. The Badische Co. (D. R. P. 285,703/13) claim the use of a water-gas enriched by carbon

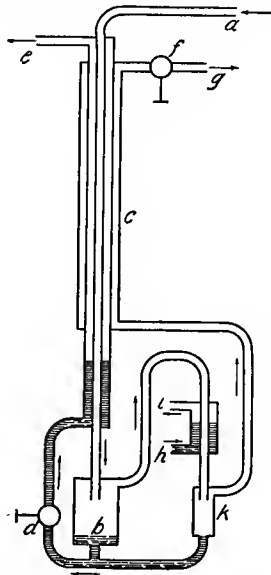

FIG. IX. Diagrammatic Representation of Linde-Frank-Caro Liquefaction Process.

monoxide and nitrogen from the vaporisation process. Since both these gases show a large positive Joule Thomson effect, extra cooling is realised per unit of hydrogen produced. In this way supplementary liquid air cooling is to be avoided. As far as is known, this project is not in technical use.

*The Claude Process.*—According to the claims of Claude<sup>3</sup> the compressed and purified water-gas is pre-cooled in twin heat interchangers, one half of the water-gas by the vaporised carbon

<sup>3</sup> F. P. 445,883/1912.

<sup>4</sup> Soc. L'Air Liquide, U. S. P. 1,135,355 and 1,212,455.

monoxide, the other half by the expanded hydrogen. After passing through these preliminary coolers the two water-gas streams unite and pass to the separation system which is in reality a complex tubular reflux condenser. (See Fig. X.) In the lower half of the tubular system the external cooling agent is the vaporising carbon monoxide-nitrogen fraction. In the upper half, hydrogen, which has been expanded with performance of external work,

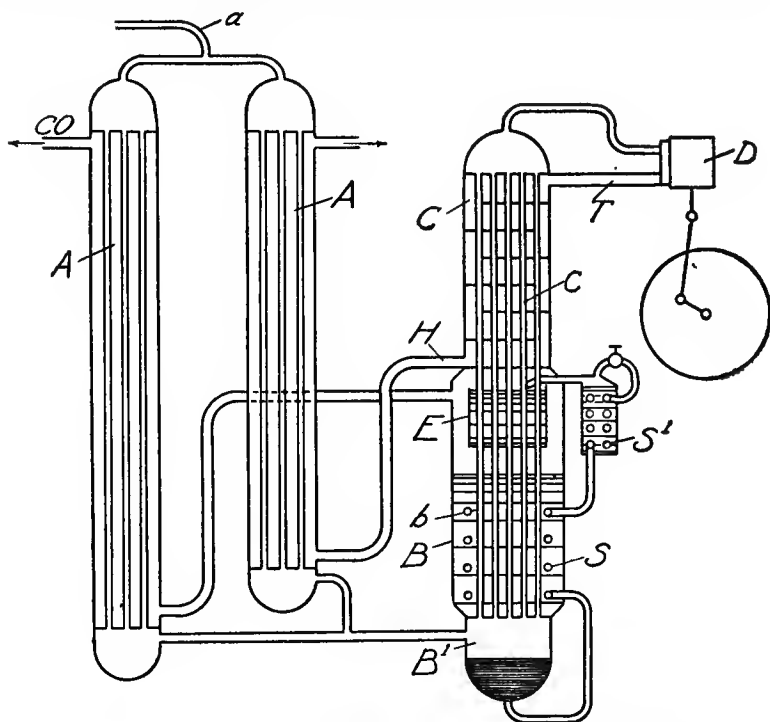

FIG. X. Diagrammatic Representation of Claude Liquefaction Process.

utilised. The separation of the carbon monoxide occurs within the vertical tubes. The progressive lowering in temperature with increasing height of the tube may be noted. The lowest end of the tubes are surrounded by carbon monoxide-nitrogen liquid vaporising at atmospheric pressure. Through a coil immersed in this liquid there passes also the compressed carbon monoxide liquid from the collecting vessel in the base of the separator. The compressed liquid is thereby cooled. In an auxiliary heat exchanger, expansion of the liquid to atmospheric pressure occurs and the

liquid flows thence, first to a tank in the uppermost portion of the lower half of the separatory system, and then to the lower half. The gases, from which much of the carbon monoxide has been removed, therefore, come in contact with the coldest carbon monoxide liquid. The liquid is coldest because it contains a certain proportion of dissolved hydrogen which lowers the boiling point. In the upper half of the separator the process is a simple heat exchange between compressed and expanded hydrogen-rich gases. If the auxiliary heat exchanger and the tank in the upper portion of the carbon monoxide section be eliminated, simplification ensues, but the purity of hydrogen obtained is not so great.

*Composition of the Two Gas Fractions.*—As shown in the gas composition flow sheet previously given, approximately 41 per cent by volume of the original water-gas emerges from the liquefaction process in the hydrogen-rich fraction. The carbon monoxide fraction comprises a further 41 per cent of the original water-gas, losses in the preliminary purification process representing some 15-20 per cent of the total gas input.

The normal purity of hydrogen obtained corresponds closely to a gas of the following composition:

Hydrogen .....	97-97.5
Carbon monoxide .....	2- 1.7
Nitrogen .....	1- 0.85

Of the total impurity, approximately two thirds is carbon monoxide and one third nitrogen. In steady operation, the variation is slight, but, if operation be intermittent, the percentage of impurities is consistently high. For the first few hours after starting up the system it is difficult to attain a purity higher than 96 per cent hydrogen. The gas prepared by this process is remarkably free from water vapor, sulphur and phosphorus compounds, though this freedom is attained with simultaneous increase of operational difficulties. For, at the working temperatures, these impurities are solid and gradually accumulate in the coils of the liquefaction system causing stoppages. When such choking of the coils has occurred, it is necessary to stop the process, warm up the system and thaw out the impurities. As a consequence, an extra liquefaction unit is to be recommended to serve as a standby for use in such emergencies.

The carbon monoxide-rich fraction averages 75-80 per cent carbon monoxide and contains in addition some 10-15 per cent of the original hydrogen content of the water-gas.

*Utilisation of the Carbon Monoxide Fraction.*—The carbon monoxide-rich-gas, after evaporation, is utilised as a source of power for the whole plant. Thus, in the Badische plant at Oppau, operating with the Linde process, each unit of 35,000 cubic feet capacity was equipped with a gas engine, of 500 H. P., which consumed the carbon monoxide produced by the Linde system. In yet another plant, of smaller capacity, a larger engine (Nuremberg-Lilleshall) of 800 H. P. was installed but this plant was not operating to full capacity. The power thus furnished is adequate for the whole of the plant requirements. From a single main shaft driven by the gas engine there may be simultaneously operated (a) the water-gas compressor, (b) the air compressor for the liquid air, (c) the water compressor for the carbon dioxide-removal plant, (d) the ammonia refrigeration plant, (e) the blowers for the water-gas plant.

*Plant Details.*—The water-gas compressor is of a capacity equal to two and one-half times the hydrogen production. A double-line 3-stage compressor, raising the pressure to 300 lbs. per square inch, has been found suitable for the larger units.

For air compression in the Linde system a 5-stage air compressor is recommended. The capacity of this compressor varies largely with the conditions under which the process is operated. The actual needs of auxiliary liquid air or nitrogen are small owing to the high efficiency of the heat exchanger systems and the care bestowed on the lagging of the plant. Where, however, utilisation may be made, as by-products, of the nitrogen and oxygen, which may be obtained, it follows that the size of such requirements and the available power capacity of the plant will determine the size of the liquid air auxiliary. In the Oppau plant sufficient liquid air was produced to supply the nitrogen requirements of the ammonia synthesis section of the plant.

Plant and operational details in the case of the pressure water-washing process of carbon dioxide removal will not receive extended discussion at this point since they received such treatment in the account of the operation of the continuous water-gas catalytic process. (See Chapter III, pp. 79-80.)

Since carbon dioxide and water vapor are solid at the temperature of liquefaction of carbon monoxide the removal of these impurities must be most rigorous. Consequently, the gas after treatment with water under pressure is freed from traces of carbon dioxide by a supplementary scrubbing process using caustic soda liquor. This may best be accomplished in a pressure scrubber (see p. 80) or by passage through a series of pressure wash bottles. Thus, for a plant treating 41,000 cubic feet of water-gas, four steel wash bottles 3 feet in diameter by 12 feet high, worked in sets of two, each set for 12 hours each, are adequate for complete removal of the residual carbon dioxide from the water-washing process.

The ammonia-refrigerator plant is of the usual type as far as the production of the low temperature is concerned. The system to be cooled consists of a set of coils through the interior of which the gas to be freed from water is passed. It is necessary, however, to provide duplicate sets of the coils in which the gas undergoes the cooling process since they become choked by separation of solid impurities, mainly ice, and must at intervals be thawed out. The capacity of the plant is readily determined by the volume of water-gas treated and by the maximum moisture content of the gas at the working pressure.

*General Remarks on the Efficiency of the Process.*—The present high cost of fuel centres interest at once on the ratio of water-gas consumed to hydrogen output. The data already given show that this ratio is 2.5 to 1, or in other words practically the same value as in the steam-iron process when systematically controlled. In the present case, the extra gas is used to produce power for plant operation; in the steam-iron process it is used for maintaining the reaction temperature. In the latter process, however, an additional fuel bill for steam for the hydrogen making reaction is generally incurred, though it is undoubtedly true that this could be more than supplied in a well-ordered plant from the waste-heat of the process. On water-gas consumption the merits of the two processes are therefore about equal, both, however, being more expensive in this regard than the water-gas catalytic processes previously considered. Plant cost, involving fixed charges on a large amount of rapidly moving heavy machinery, should be relatively high. Renewal, however, should be less than

in the steam-iron process where deterioration of the retorts and disintegration of the contact mass represent heavy items of expenditure. A much higher purity is readily attained in the steam-iron process than is possible in the simple liquefaction process. The product in the latter case, with a 2 per cent carbon monoxide content, is frequently impossible of use without special purification. Consideration of the methods of such purification will be specially dealt with at a later stage. They all involve, however, additional expense. Where such purification is not requisite it is often desirable owing to the higher efficiency of utilisation that is possible. Thus, hydrogen from the steam-iron process is undoubtedly a more efficient agent for the hydrogenation of oils although the product of the simple liquefaction process is in use for such purposes (Bedford-Erdmann process). In the Linde system, the nitrogen obtained represents an item in favor of the process when the hydrogen is to be used for ammonia synthesis. But, the best commentary on its efficiency as contrasted with the water-gas catalytic process hydrogen for purposes of ammonia synthesis is that the Badische Co. at Oppau, and later at Merseburg, built all units, subsequent to the first three, to operate the catalytic process.

*Miscellaneous Physical Methods of Preparing Hydrogen from Water Gas and Other Technical Gases.*

Liquefaction is not the only physical agency which has been proposed for the production of hydrogen from water-gas. Processes based on diffusion, centrifugal action, preferential solubility and on solution coupled with refrigeration have received attention.

As early as 1891 Pullmann and Elworthy suggested the production of a hydrogen-carbon dioxide mixture by interaction of steam and incandescent coke and the separation of the carbon dioxide by diffusion through diaphragms of plaster of Paris or of porous porcelain. The same proposals relative to the constituents of water-gas are contained in a French patent (372,045/1906) to Jouve and Gautier, unglazed porcelain to be used as the diffusion medium. The proposal is revived with modifications in a recent patent to Snelling (U. S. P. 1,174,631/1916) according to which water-gas is to be resolved into its constituents

by diffusion at temperatures above 800° C. through porous materials, e. g., alundum, coated with platinum or palladium. With such a coating a pressure-tight septum could be produced. In such case, the diffusion process could be accelerated by subjecting the gas undergoing diffusion to pressure.

A considerable reduction in the content of foreign gases present in hydrogen can be produced in this manner. Reductions in the carbon monoxide concentration from 30 per cent to 5 per cent by one diffusion operation are recorded in the patent literature. The time factor, however, is, in general, noticeably absent from such specifications and yet is of fundamental importance in the technical application. It is hard to visualise the diffusion process successfully applied in the industry.

Numerous proposals to separate hydrogen and carbon monoxide by centrifugal action have been made. The patent specifications of Mazza<sup>4</sup> and of Elworthy<sup>5</sup> are suggested for reference. They have no technical significance.

Dewar's experiments with liquid air showed that hydrocarbons could be removed from coal gas by cooling the latter to liquid air temperatures. Bergius suggested this method of purification for hydrogen produced by his process (see Chapter VI, p. 123), using charcoal cooled in liquid air as absorbent for the impurities. Curme<sup>6</sup> suggests the removal of condensable hydrocarbons such as acetylene and ethylene in this way, methane and hydrogen passing on if the carbon be maintained at ordinary temperatures. Soddy<sup>7</sup> similarly utilises this property of charcoal to remove ethylene and benzene from coal-gas and coke-oven gas. Adam<sup>8</sup> utilises the same agent for removal of carbon disulphide and naphthalene from coal-gas.

Considerable attention has been given recently to a proposal of G. Claude<sup>9</sup> for the preparation of hydrogen from mixtures such as coke-oven gas. The patents claim the production of hydrogen by solution of the other constituents in solvents such as alcohol, acetone or benzene employing very high pressures (500 to 2,000 atmospheres), or in ether at - 60° C. at pressures

<sup>4</sup> B. P. 12,194/1902.

<sup>5</sup> B. P. 10,581/1906.

<sup>6</sup> U. S. P. 1,181, 116/1916.

<sup>7</sup> B. P. 125,253/1919.

<sup>8</sup> U. S. P. 127,431/1919.

<sup>9</sup> B. P. 130,092/1918; 130,358/1918.



of 50 to 300 atmospheres. Hydrogen is the least soluble constituent of the mixtures. It is a moot point, however, as to how much more soluble the other gases are under the given conditions. Published data are lacking on this point. It must be observed, however, that, unless there is a marked solubility differential between hydrogen and the other gases, the process will be impossible merely on the ground of hydrogen losses alone. It must be remembered that these losses will be, in the purified gas, determined by the solubility of hydrogen at the working pressure in the solvent chosen.

## Chapter V.

### Hydrogen by Electrolysis.

The production of hydrogen from water by the electrolysis of dilute aqueous solutions of acids or alkalis is the simplest method of producing this gas which is operated technically. In the last analysis these processes reduce to the decomposition of water into its elements with the aid of the electric current, whereby, from 2 gram-mols of water, 2 gram-mols of hydrogen and 1 gram-mol of oxygen are simultaneously produced

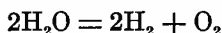

Given a well-designed, well-constructed electrolytic hydrogen plant, a continuous supply of hydrogen, in a high state of purity, with a minimum of labor and plant control, can be obtained with a high degree of efficiency. Offsetting the ease of production by the electrolytic method, however, are high initial plant costs and high cost of electrical energy utilised per unit of hydrogen produced. As it is these factors which tend to eliminate electrolytic hydrogen from extended industrial use, a careful analysis of their importance in the problem will first be considered. This completed, a résumé of typical industrial units and their especial features will be given.

The relationship between quantity of electricity flowing and the volume of hydrogen produced is given by the laws of electrolysis first enunciated by Faraday. These laws state:

(1) The quantity of an electrolyte which is decomposed is directly proportional to the quantity of current which is flowing.

(2) The mass of a substance liberated by a given quantity of electricity is proportional to the equivalent weight of the substance.

The equivalent weight of an element is equal to the atomic weight divided by the valency. Since many substances have varying valencies, it may be well to define the equivalent weight in reference to the number of ionic charges which the substance

is carrying in the solution in which the electrolysis is taking place. In such case the equivalent weight is the weight in grams of one gram ion divided by the number of ionic charges which the ion carries. The quantity of electricity required to liberate one equivalent weight of any substance is, by Faraday's second law, always the same and is 96,500 coulombs (ampere-seconds).

Hence, it may be concluded that 96,500 coulombs liberate

$$\frac{1}{1} = 1 \text{ gram of hydrogen (since the ion is H}^+) \text{ or for oxygen}$$

$$\frac{16}{2} = 8 \text{ grams of oxygen (since the ion is O}^{2-}). \text{ Correspondingly,}$$

for iron in ferric chloride, the equivalent weight is  $\frac{56}{3} = 18.66$  grams (since the ion is  $\text{Fe}^{+++}$ ), but in ferrous sulphate,  $\frac{56}{2} = 28$  grams (since the ion in this case is  $\text{Fe}^{++}$ ).

For technical purposes it is more convenient to calculate with ampere-hours instead of coulombs and with gas volumes in place of equivalent weights. The following list gives some of the more important constants in reference to the relationships existing between quantity of current and gas volumes produced in electrolytic processes yielding hydrogen and oxygen:

- 1 Ampere-hour liberates 0.03731 gram equivalents.
- 1 Ampere-hour liberates 0.01482 cub. ft. of dry hydrogen at N. T. P.
- 1 Ampere-hour liberates 0.00741 cub. ft. of dry oxygen at N. T. P.
- 1 Ampere-hour liberates 0.01585 cub. ft. of dry hydrogen at 20° C. and 760 mm. pressure.
- 1 Ampere-hour liberates 0.00792 cub. ft. of dry oxygen at 20° C. and 760 mm. pressure.
- 1,000 cub. ft. of hydrogen at 20° C. and 760 mm. pressure require approximately 63,000 ampere-hours for their generation by electrolysis.

Consideration may now be given to the other factor operating in the problem of necessary electrical energy for the process, the intensity factor or decomposition potential required.

Theoretically, the work necessary to produce the two gases hydrogen and oxygen from water by the aid of the electric current is exactly equal to the work which may be produced when these two gases operate as gas electrodes in a reversible cell, the reaction occurring being the production of water. Independent methods of deduction of this work quantity based upon thermodynamical reasoning and on experimental observation show that the electromotive force of a hydrogen-oxygen cell should be in the neighbourhood of 1.23 volts.<sup>1</sup> Hence, an electromotive force of 1.23 volts should be capable of liberating hydrogen and oxygen continuously from an aqueous solution of an acid or an alkali having electrodes of platinum were other effects not present. It has been shown, however, by many investigators, that the minimum voltage necessary for the continuous decomposition of water in a solution, for example, of sodium hydroxide, with platinum electrodes, is in the neighbourhood of 1.7 volts. Furthermore, the decomposition voltage is dependent on the nature of the electrode material, on the current density and on various other variables in the process. Even during the process of electrolysis, the requisite voltage may change with changes brought about in the solution by the electrolytic process.

The cause of the divergence between the electromotive force obtainable from a reversible hydrogen and oxygen cell having platinum as the medium for the gas electrodes, and, on the other hand, the decomposition potential required for continuous electrolysis of aqueous alkali or acid solutions with platinum electrodes, is to be sought in the phenomenon of over-voltage. Experimentation shows that the behaviour of the platinum electrode at which hydrogen is being liberated is practically normal. At the electrode liberating oxygen, however, an electromotive force, greater than that which oxygen is capable of yielding when acting as gas electrode, is required to bring about the continuous liberation of oxygen gas from the solution. This excess electromotive force represents in this particular case the over-potential or over-voltage.

With other electrodes than platinum, the phenomenon of over-voltage is not confined to the oxygen electrode. The reversible discharge of hydrogen on a platinum electrode becomes irreversible on other metallic electrodes. Thus, polished nickel

<sup>1</sup> Lewis, *Z. physik. Chem.*, 1906, 55, 449.

has a hydrogen over-voltage in excess of that of polished platinum by about 0.12 volt, iron an over-voltage of 0.08 volts. Since these metals form the principal constituents of the electrode materials for hydrogen-oxygen electrolytic generators it is of interest to tabulate the respective over-voltages in respect to each gas and to compare the data with the corresponding figures for platinum.

<i>Electrode Material</i>	<i>Oxygen Over-voltage</i> <sup>2</sup>	<i>Hydrogen Over-voltage</i> <sup>3</sup>	<i>Total Over-voltage</i>
Polished platinum .....	0.44	0.09	0.53
Platinised platinum .....	0.24	0.005	0.245
Polished nickel.	0.12	0.21	0.33
Spongy nickel..	0.05	....	....
Iron .....	0.24	0.08	0.32
Cobalt .....	0.13	....	....

It is thus evident that nickel electrodes require the least excess voltage to overcome irreversibility of the electrodes with reference to the two gases. As iron is not greatly inferior to nickel, however, in this respect, and as it is a considerably cheaper electrode material, it follows that iron will as a rule be the preferred metal for electrodes. These theoretical considerations suggest however that nickel-plated iron would be a suitable electrode material and it will be shown later that this material has come into extended use. A nickel-plated anode and an iron cathode would represent the best electrode arrangements of these two metals from the standpoint of over-voltage.

The secondary factors influencing over-voltage are current density, composition of electrolyte and nature of the electrode surface. The first two factors are, however, of so much greater importance in respect to the other properties of the cell, such as electrode area and strength of solution employed, which governs internal resistance, that their effect on the excess voltage required is of secondary importance. The influence upon over-potential

<sup>2</sup> Coehn and Osaka, *Z. anorg. Chem.*, 1903, 34, 86.

<sup>3</sup> Caspari, *Z. physik. Chem.*, 1899, 30, 89.

exercised by the nature of the electrode surface is worthy of consideration in respect to economy of electrical energy. Rideal has shown\* in the case of copper and zinc that the change from a bright microcrystalline surface to an amorphous surface is accompanied by a continuous decrease in the over-potential of an electrode. If the same holds true for nickel, it would be anticipated that from the standpoint of over-voltage the ideal electrode material would be iron with a firmly adhering coating of amorphous nickel.

Assuming a true decomposition potential, in absence of over-potential, equal to 1.23 volts, it follows that the minimum decomposition potential with over-voltage from technically feasible electrodes, and that, therefore, of practical importance, is in excess of 1.5 volts. The actual value will vary with the electrolyte chosen and with the operating conditions.

In practice, such voltages are however impracticably low, due to the resistance of the electrolyte and to the presence in the cell of devices, generally diaphragms, inserted to prevent intermixing of the gases. In attaining this latter end, the resistance of the cell is increased and as a consequence the applied voltage must be raised. Voltages, therefore, of 2 to 4 volts per cell are usual in electrolytic hydrogen production.

The resistance of the electrolyte to the passage of the current is reduced to the lowest possible limit by employing solutions of electrolytes showing maximum conductivities. Thus, alkaline electrolytes containing 10-30 per cent alkali are in use. Certain early commercial units employed sulphuric acid solutions; for example, the Schoop cell (1900) used acid having a density of 1.235 (32.0 per cent  $H_2SO_4$ ). Difficulties due to corrosion in the cells have practically led to the abolition of the acid cells and most modern units are made with alkaline electrolytes. The heat produced by the resistance of the electrolyte is conserved, a working temperature of 70° C. being maintained within the cell. This increased temperature tends also to diminution of resistance and, hence, to decrease of applied voltage and higher energy efficiency.

*Mechanism of Electrolysis.*—The electrolytic dissociation of pure water into hydrogen and hydroxyl ions

\**J. Am. Chem. Soc.* 1920, 42, 104. In this article may also be found a discussion of over-voltage together with a literature résumé of the subject.



is, as is well known, extremely small in magnitude. Addition of hydrogen ions in the form of sulphuric acid will diminish the concentration of hydroxyl ions in agreement with the law of mass action applied to electrolytic dissociation. Similarly, addition to water of hydroxyl ions in the form of alkaline hydroxides will suppress the hydrogen ion concentration of water. Consequently the conclusion is inevitable that in such solutions the formation of hydrogen and oxygen by electrolysis is not due to the simultaneous discharge of the two ions as indicated in the equations

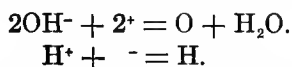

Secondary reactions predominate in either acid or alkaline electrolytes. Thus, with potassium hydroxide solutions, the hydrogen forming reaction is, in the main, undoubtedly, the interaction of discharged potassium ions with water.

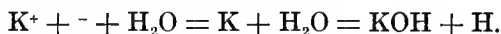

In solutions of sulphuric acid, the oxygen is, correspondingly, chiefly produced by reaction with water of discharged sulphate ions



When a solution of a neutral salt is electrolysed, both hydrogen and oxygen are the products of secondary reactions, as is readily indicated, for example, in the electrolysis of sodium sulphate solutions by the increasing acidity at the anode and the increasing alkalinity at the cathode.

It is thus evident that to speak of the industrial production of hydrogen and oxygen by electrolysis as the electrolysis of water is not strictly precise. As however, apart from local variations in concentration, the net change in the solution is the removal of water, the term is frequently applied to the processes under consideration.

*Earlier Forms of Apparatus.*—Examples of the earlier types of apparatus used in electrolytic hydrogen and oxygen production have been given by J. W. Richards.<sup>5</sup> According to this author

<sup>5</sup> *J. Franklin Inst.*, 1905, 160, 387.

the plant installed by D'Arsonval in 1885 probably represents the first electrolytic oxygen generator for laboratory purposes. A thirty per cent solution of sodium hydroxide served as electrolyte, the electrodes were of cylindrical sheet iron and a current density of 2 amperes per square decimeter with a current consumption of 60 amperes was employed. Only oxygen was collected and the anode compartment was enclosed in a woolen bag which served as diaphragm.

Latchinoff<sup>e</sup> in all probability constructed the first large scale apparatus. He employed asbestos cloth diaphragms. Using an alkaline electrolyte of 10 per cent sodium hydroxide solution, he employed iron electrodes, a current density of 3.5 amperes per square decimeter and an applied voltage of 2.5 volts per cell. With a 5-15 per cent sulphuric acid solution, lead anodes and carbon cathodes were employed. Latchinoff also constructed apparatus with bipolar electrodes, the one side of the electrode acting as cathode, the other as anode. A series of forty cells was used on an ordinary direct current lighting circuit, with a current density of 10 amperes per square decimeter. In yet another apparatus, electrolysis was conducted under pressure. Compression to 120 atmospheres was possible, the containing vessel being of heavy iron. A system of floating valves kept the pressures of the two gases equal in the apparatus.

The Garuti process originated in 1892, and the innovation then made was the use of metal diaphragms to decrease the internal resistance and to avoid expense in upkeep of porous diaphragms. It was found that the metal diaphragm does not function as a bipolar electrode provided it does not reach to the bottom of the cell and provided the applied voltage is kept below twice the decomposition voltage of the electrolyte or in other words below about 3.0 volts. The original cells were made of sheet lead and were filled with dilute sulphuric acid as electrolyte. Subsequent designs employed sheet iron for electrodes and diaphragms, and sodium hydroxide solutions. The electrodes were spaced about 12 mm. apart, the diaphragm in between being perforated with small holes in the lower parts. (Garuti and Pompili B. P. 23,663/1896.) This feature still further reduced the internal resistance of the cell. In modern units of the Garuti cell all soldering of joints is avoided. The metal diaphragm projects

<sup>e</sup> B. P. 15,925/1888.



below and is insulated from the electrodes by a wooden comb the teeth of which serve to space the electrodes. The diaphragm is perforated opposite to the centres of the electrodes and the holes are covered with wire gauze in order to minimise admixture of the gases. A series of the cells are arranged together and immersed in a single tank of electrolyte. The gases are collected in their respective mains, hydraulic seals being employed to prevent pressure increase and mixing of the gases. The electrolyte used varies. Sodium hydroxide in 10-30 per cent solution has been used as well as 26 per cent potassium hydroxide solution. The applied voltage is about 2.5 volts per cell. Current densities of 25-30 amperes per square foot are possible. A current efficiency of 96 per cent is claimed. The Garuti-Pompili cell is an excellent example, therefore, of the metal diaphragm cell. It has been employed in this country by the American Oxhydric Co.

The Schmidt process<sup>†</sup> introduced the filter press type of cell, the metallic units of the system functioning as bipolar electrodes on one face of which hydrogen is evolved and, on the other, oxygen. The gases are kept from intermixing by means of asbestos or other non-conducting porous diaphragms, the gases being led away from the generator-space by channels similar to those used in filter-press practice for the discharge of the filtrate. The number of bipolar units in series with one another is determined by the current available. Thus a 40 electrode unit is suitable for a direct current supply at 110 volts. The electrodes, which vary in form and shape as do filter presses, are separated from one another and insulated by the diaphragm which is reinforced at the edges and on both sides with rubber in the shape of the outside flange of the electrode. Distilled water is supplied to the system from a tank situated at a higher level than the cells by a pipe system passing to channels formed by holes in the base of the electrodes. To these channels also flows the spray separated from the evolved gases in the gas-collecting chambers placed alongside the water supply tank.

Various strengths of alkali hydroxide and alkali carbonate solutions have been employed in the filter press type of cell. The voltage drop varies from 2.3 to 2.8 volts per cell while amperages averaging 20 to 30 amperes are common.

<sup>†</sup> D. R. P. 111,181/1899.

The filter press type is compact and simple in construction. It requires, however, a frequent overhauling to maintain it in a gas-tight condition, free also from leaks in the liquid system.

Plants of the filter press type are made in this country by Schriver and Co., of Harrison, N. J., and the International Oxygen Co., of Newark, N. J. In Europe, erection of Schmidt units has been undertaken by the Oerlikon Co.

Schoop<sup>8</sup> devised an electrolyser having electrodes surrounded by non-porous, non-conducting diaphragms. A cylindrical cell contains two anodes and two cathodes, the electrodes consisting of tubular metal cylinders completely surrounded by clay or glass collecting cylinders. Both anodes and cathodes are placed diametrically opposite to one another in the cylinder, the evolved gas being led off to the mains by effluent pipes connected to the electrodes of like polarity.

Both acid and alkaline electrolytes have been used with the Schoop type of cell. With aqueous sulphuric acid as electrolyte, a lead tank and lead electrodes were used. The voltage required in such case is high and of the order of 3.6 volts. With alkaline electrolytes iron is the metal used and a voltage drop of 2.25 volts is adequate.

The Schuckert system employs a bell-collecting system. Iron electrodes are placed in a tank, alternately anode and cathode. Over each electrode is placed an iron bell, the bells being separated from each other by a screen of insulating material which projects the full breadth and depth of the containing tank. This tank is insulated from the electrodes and does not play any part in the electrolysis. A tank usually contains four anodes, four cathodes and eight collecting-bells from four of which hydrogen is led off by pipes to the main, oxygen being removed from the others.<sup>9</sup> An electrolyte of 20 per cent sodium hydroxide solution is normally employed. The floor space required is comparatively large. Several plants on this system have been erected in this country.

The International Oxygen Co., in an early form of the unit systems now common in electrolytic hydrogen and oxygen production, used a tank cell in which the tank served as cathode. The tank was of steel and was mounted on insulators; it had an

<sup>8</sup> Austrian Patent 1,285/1900.

<sup>9</sup> Cf. Burdett Cell, p. 117.

annular ring to hold water at the top and was closed by means of an insulated iron cover. To this cover was attached an anode in the form of a cylinder perforated with holes, the tank being divided into two compartments by an asbestos sack suspended from a non-conducting perforated plate around the anode lead. The top of the compartments was sealed by means of two hydraulic seals, formed by two flanges projecting downwards from the cover of the tank, the one somewhat larger than the anode projecting into the solution of electrolyte, the other sealing the exit from the cathode by projecting into the water-filled annulus. Oxygen from the anode was collected within the inner flange and passed away through an exit pipe to the collecting mains. Hydrogen generated on the tank walls passed on the outside of this flange to its exit pipe.

The cells operated at an average voltage of 2.6 volts per cell. They had a current capacity of 400 amperes per unit with an output of about 6 cubic feet of hydrogen and 3 cubic feet of oxygen per cell per hour.

*Modern Forms of Plant.*—The tendency in design of plant for electrolytic hydrogen and oxygen in recent years has been in the direction of increased economy of necessary floor space. Furthermore, the production of units having a largely increased current capacity is now engaging the most serious attention of the constructional engineers of the electrolytic gas industry. The object in such case is a diminution of the capital cost of the necessary plant, to bring it more approximately into line with the outlay involved in the production of these gases by other methods. In the case of oxygen, liquid air oxygen has been the active competitor, while, with hydrogen, any other of several well-tried chemical processes can be erected at a very much lower capital cost for an equivalent output. The purity of gas product which is possible by processes of electrolysis is the principal reason for energetic prosecution of attempts to cheapen and improve the electrolytic processes.

The trend in design, as well as the manner in which safety and surety of operation are being secured, may conveniently be demonstrated by describing the plants which modern electrolytic gas manufacturers are producing. The descriptions given in the

following are largely taken from the excellent bulletins which these manufacturers issue.

*The International Oxygen Company's Type 4-1000 Unit Generator.*—The most recent form of electrolytic hydrogen and oxygen generator which this organisation produces is a unit-type generator designed with a view to simpler mechanical and electrical construction, occupying a minimum amount of floor-space per unit of gas evolution and showing high operating economy and flexibility of load.

As the term "unit" implies, each generator is self-contained and complete in itself, capable of generating both gases at a rate determined by the applied amperage. An installation is made up of a number of such units, the number being determined by the quantity of the gases required.

Each of the units in the latest type of cell requires a floor space of 4 inches by 40 inches and, with the necessary pipe connections, needs a head-room of about 6 feet. (See Fig. XI.)

The unit is a thin cast-iron box made in rectangular form to which is bolted two cast-iron side plates serving as electrodes. The cavity between the electrodes is divided by a diaphragm of asbestos fabric clamped directly by metal, rubber or cement of any kind being conspicuously absent. This diaphragm forms the two chambers of the cell.

In the upper part of the rectangular box frame are reservoirs for the electrolyte, from which it is fed to the two sides of the diaphragm. The two gas chambers which permit the separation of the gases from moisture and electrolyte spray are also located in the upper part of the cell frame and serve as gas-traps and gas off-takes, as well as an automatic pressure-controlling device. At the bottom of the frame are communicating passage ways which permit circulation of electrolyte on the two sides of the diaphragm. In the base of the cell a plug valve and draining device is provided which permits the electrolyte to be drained from the cell when desired.

The cast-iron electrodes are insulated from the frame and from one another. A heavy packing rim of insulating material is used, and the bolts which hold the electrodes to the frame are insulated by mica bushings. The electrodes are reinforced by outside ribs and, on the inside, carry a great number of pyramid-

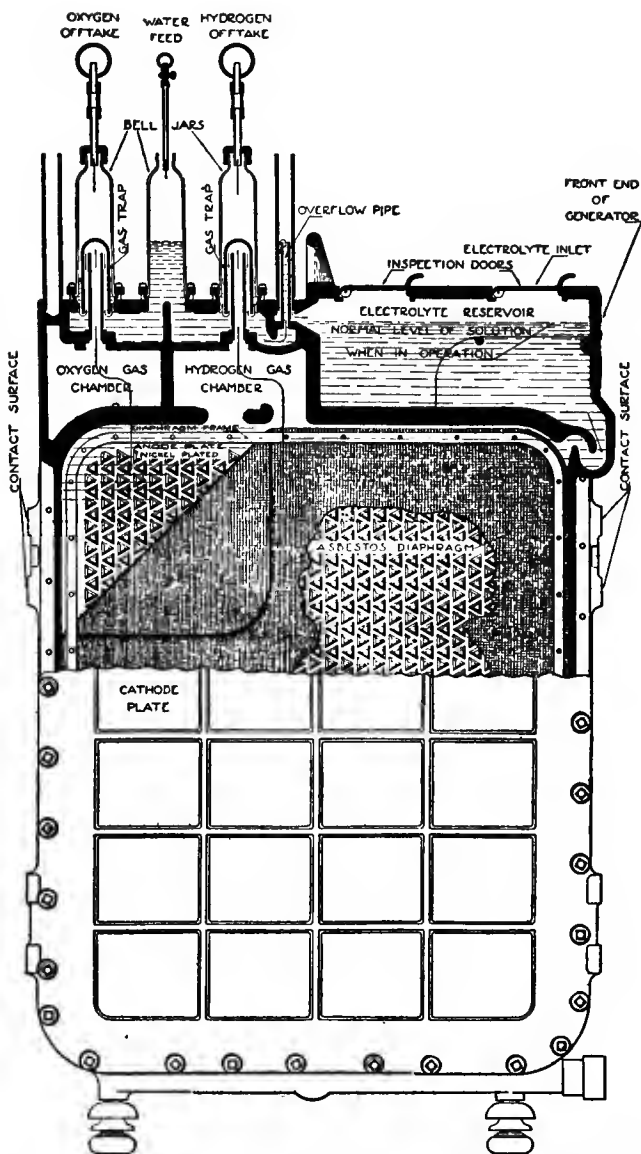

FIG. XI. International Oxygen Company's Type 4-1000 Unit Generator.

shaped projections. These increase the electrode area in contact with electrolyte and facilitate release of the gases at the generating surface. The inner surface of the cathode is specially treated and the inner surface of the positive electrode, the anode, is heavily nickeled. In this way, the cell uses one iron and one nickel electrode and so, the over-voltage is minimised (see p. 105) and electrical efficiency is increased. The nickel deposit also prevents the formation of oxide of iron which occurs with iron electrodes at the oxygen-yielding electrode.

The diaphragm is impermeable to the gas bubbles but is of a texture sufficiently porous to avoid development of too high an internal resistance. The edges of the diaphragm are held between a flange, projecting inward from the frame, and a metal clamping rim bolted to this flange.

The gas off-takes are supported on insulated brackets which in turn rest directly on the cells. They are fed from glass bell-jars which form part of the insulation between the cell and off-takes. The bell-jars also act as indicating devices of the pressure in the off-take lines. The cells are also insulated from the earth by glass insulators protected by cast iron petticoats.

The normal current rating of the cell is 600 amperes and the voltage required at this amperage is 2.2 volts. The gas yield under such circumstances is 4.8 cubic feet of oxygen and 9.6 cubic feet of hydrogen per clock hour. This means a kilowatt hour efficiency of 3.65 cubic feet of oxygen and 7.3 cubic feet of hydrogen.

The cell is designed to operate under widely varying conditions of current with a high level of efficiency. Good economy is claimed over a current range from 200 to 1,000 amperes. At the lower figure a higher electrical efficiency is possible since the applied voltage per cell need not exceed 1.85 volts. The power consumption per unit of gas produced will therefore be some 16 per cent less than at normal rating, or a production of 8.7 cubic feet of hydrogen per kilowatt hour. The yield per cell per unit of time will, however, be correspondingly smaller. When operating at 1,000 amperes the cell requires an applied voltage of about 2.54 volts. The power consumption is therefore some 15 per cent greater than at normal load. This corresponds to 6.32 cubic feet of hydrogen per kilowatt hour. An increased yield per cell per hour is attained. This wide variability in current range repre-

senting a varying hydrogen yield of from 400 cubic feet to 2,000 cubic feet of hydrogen per 24 hour day is claimed as an especial feature of the Type 4—1,000 unit generator. Naturally the particular mode of operation chosen will depend on a number of factors, including cost of current, capital cost of plant and nature of the gas consumption, whether steady or variable.

Compactness of plant per unit of gas generated is also claimed for this type of cell. At normal rating of 600 amperes, the production per 24 hours is somewhat over 200 cubic feet of hydrogen per square foot of floor area. At 1,000 amperes this figure is raised to 350 cubic feet of hydrogen per 24-hour day.

The purity of the gases is high, the hydrogen being purer than the oxygen. Average purities claimed are 99.7 per cent for hydrogen and 99.5 per cent for oxygen.

*The Electrolabs Levin Generator.*—This generator is also of the unit type built in two sizes, Type A and Type B. These cells are built exactly alike except as regards dimensions. Type A has external dimensions of 30 inches by 25 inches by  $6\frac{1}{4}$  inches and a rated current capacity of 250 amperes. Type B is 43 inches by 37 inches by  $8\frac{1}{2}$  inches with a normal current capacity of 600 amperes. Under normal current ratings the hourly hydrogen yield is 4 cubic feet in the smaller type and 9.6 cubic feet in the larger unit.

The Levin cell contains three compartments. (See Fig. XII.) Oxygen is generated in the two outer compartments, hydrogen in the centre compartment. Two sheet metal frames carrying two asbestos diaphragms serve as the separating media between the compartments. The electrodes are quite independent of the casing, they are separated from and securely fixed within the casing by blocks of asbestos. The electrodes are plated, the cathode with cobalt the use of which is a special patented feature of the cell, the anode with nickel. Rideal<sup>10</sup> records a hydrogen over-voltage for cobalt varying between 0.0 and 0.03 volts, compared with 0.01 to 0.21 volts for nickel. For the oxygen over-voltage Coehn and Osaka record for cobalt the value 0.13 volt.<sup>11</sup> An alkaline electrolyte is employed in the Levin cell.

Each compartment has a separate water feed which also serves

<sup>10</sup> *Loc. cit.* p. 106.

<sup>11</sup> *Z. anorg. Chem.* 1903, 34, 86.

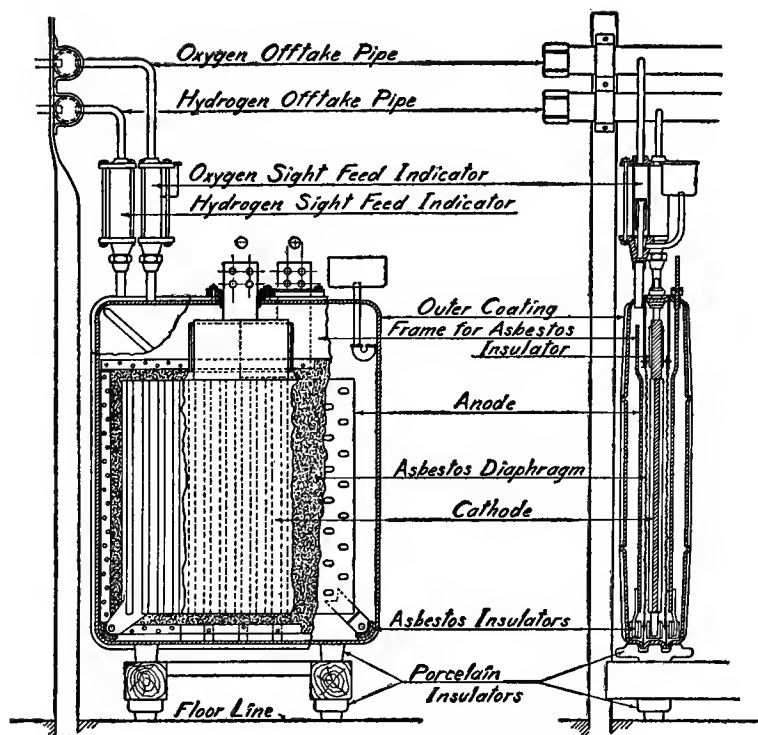

FIG. XII. The Electrolabs Levin Generator.

as a blow-off device to vent the gas from each compartment under abnormal conditions. A sight-feed indicator is placed between the cell and off-take pipe, isolating the cell from other units in the group and also serving as a pressure regulator inside the compartments of the cell.

A special feature of the generator is that each unit is delivered entirely welded and completely and rigidly assembled. There is thus no possibility of trouble due to leaks at joints in the system. The weight per cell per unit of gas produced has been reduced in this cell to a minimum and the standardisation and simplicity of parts makes for rapidity of construction and assembly.

At normal ratings an applied voltage somewhat over 2 volts is apparently sufficient. The purity of the gases produced in this generator is noteworthy, records cited by the makers for opera-



tion over three months having shown an average of 99.85 per cent for oxygen and a hydrogen purity still higher. This points also to adequate design in the cell to ensure safety of operation.

*Burdett Manufacturing Company's Cells.*—The latest B and C-types of cell produced by this company are closed multiple-electrode cells standing in an open rectangular steel tank containing the electrolyte and completely submerged in the liquid. In this way the gas is generated underneath the liquid and any leakages are visible.

The C-type of cell is contained in a steel tank  $17\frac{1}{4}$  inches by 31 inches by 44 inches high. It weighs 750 pounds empty and 1,650 pounds filled with its solution of electrolyte. The multiple electrodes, with an asbestos diaphragm between each electrode, divide the cell into seven gas compartments, three for oxygen and four for hydrogen. The asbestos diaphragms have a free end at the base of the cell, thus allowing for shrinkage, a feature of superiority claimed for this diaphragm over the rigidly fixed type. The open end at the base insures uniform density of electrolyte and corresponding uniformity in current distribution owing to the circulation of liquor which is set up by means of the several gas compartments provided.

The gases collect in the upper portions of the cell and pass through glass lanterns to the off-take pipes. The lanterns provide for observation, washing and pressure regulation of the gas. They also serve as the vehicle through which fresh distilled water is daily fed to the cells. This feeding through the lanterns provides a means of cleansing these latter daily. The water added is led from the lanterns to the base of the cell, thus ensuring intermixture with the electrolyte.

With an electrolyte of sodium hydroxide solution, between 22-24° Be. in strength, the normal rating of the cell is 400 amperes. Under such conditions a voltage of 1.95 volts per cell is adequate. A high kilowatt-hour efficiency is therefore obtainable, corresponding to 4.08 cubic feet of oxygen or 8.16 cubic feet of hydrogen per kilowatt-hour. The efficiency is somewhat higher at lower amperages and lower with increased load. At 700 amperes the efficiency is 6.9 cu. ft. of hydrogen per K. W. H. and at 300 amperes the efficiency is 8.4 cu. ft. of hydrogen per K. W. H.

Consideration has been given by the Burdett Co. to the construction of cells having much higher amperages than those considered above. The object of such a study is obviously the reduction of capital cost in a large unit upon which considerable call for gas is to be made. If, for example, a 2,500 ampere cell could be constructed at a capital cost only some 2 to 3 times as great as the cost of a 400 ampere cell, then the installation cost of a large unit would be approximately halved. These considerations open up interesting possibilities. An analysis of costs for capital charges even suggests that it would be very advantageous, with a source of cheap power, to operate the present C type cell at considerably higher amperages than at present recommended, in spite of the lower power efficiency thereby resulting. Operating at 4,700 amperes with a modified electrode having an area of 4,500 square inches, with caustic soda of 23° Be. as electrolyte, such a cell required 2.63 volts with a working temperature of 135° F. and should require only 2.3 volts at the normal working temperature of 160° F. The interdependence of power charge, output, and capital cost and their variability from place to place make a complete discussion of the problem difficult. Discussion of the problem in relation to alkali chlorine cells has received a certain degree of attention recently.<sup>11</sup>

The engineering difficulties in the problem of high amperage cells are adjudged to be solved by the Electrolabs Co. as a result of experiments in the building of a 10,000 ampere-unit. It has been found that a unit of such size may be operated at a potential drop of 2.5 volts. On increasing the load successively by 1,000 amperes to 15,000 amperes, it was found that an additional 0.1 volt was required for each extra 1,000 amperes, so that when operating at 15,000 amperes a potential of 3 volts per unit was required. It has been estimated that a plant constructed from such units, yielding a daily output of 2,000,000 cubic feet of hydrogen, with cheap water-power current, could deliver hydrogen at a cost as low as that obtaining in the case of gas produced by the cheapest chemical methods. Even in such circumstances, however, the main cost is apparently equally distributed between capital and fixed charges on the one hand and power on the other, with minor fractions only going to labor and upkeep.

<sup>11</sup> See Wheeler, *Chem. & Met. Eng.*, 1919, 21, 437.

*Operational Procedure.*—In the majority of cases the cells are installed by the makers and production is commenced under the supervision of their staff. For satisfactory operation, subsequently, a definite routine procedure is necessary. Attention should particularly be directed to the maintenance of water level in the cells, to the purity of the gases and to the energy consumption. Occasionally a systematic check of the electrolyte and its temperature should be undertaken.

Purity tests on the gases produced, when frequently and regularly undertaken, are most useful indexes of the general well-being of the cells. A loss in purity of even one-tenth of one per cent—which will be soonest apparent in the oxygen supply—should be traced to its source. This can most easily be done, first by checking battery to battery in the whole plant to determine which is producing gas of low purity. The battery isolated, the individual cells should then be checked until the exact cell has been located and cut out of the system. Automatic recording devices (see Chapter IX) should prove of marked use in this respect.

It is to the breakdown of the diaphragm that low purity is frequently due. The composition of the asbestos employed is a factor to which the user should pay special attention. It is much easier and cheaper to make asbestos cloth with cotton as an aid in strengthening the cloth. But, to ensure cell efficiency, cotton must be rigorously excluded. The natural tendency of the asbestos to shrink in time leads to defects and hence to low purities.

The water-level must be maintained against the losses by the electrolysis and also against that carried away by the gases which leave saturated with water vapor at the temperature of the off-take pipe. In certain cells this is automatically taken care of, the water being fed to the cells from a tank under a definite pressure. In certain unit type cells, the water-feed acts also as a vent in case of abnormal gas generation. In such case control of water level is doubly important.

Voltage tests on each cell are to be recommended. In such way, breakdown of insulation may be detected and cells of low efficiency can be isolated. External insulation should also be periodically examined. Special observation of connections is

advisable—otherwise, hot contacts between terminal and electrode may develop.

*By-Product Electrolytic Hydrogen.*—Hydrogen is produced as a by-product in the electrolytic alkali industry. The electrolysis of brine to yield caustic soda

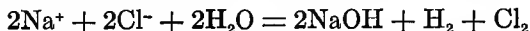

results in the simultaneous production of both chlorine and hydrogen, as much as 10,000 cubic feet of each of the gases being generated per ton of caustic soda produced by electrolysis. With 100 per cent current efficiency each ampere hour would produce 1.322 grams of chlorine, 1.491 grams of sodium hydroxide and 0.0373 grams of hydrogen. Actually, ampere-hour efficiencies obtained in practice vary from 90 to 98 per cent, the remainder of the current being spent in secondary reactions or in overcoming the same. It is apparent, however, that, in this electrolytic process, the hydrogen must remain a by-product owing to the bulk of the other products obtained, for which satisfactory disposal must be secured. At present the only openings in this direction seem to be in the soap industry and in the wood pulp and paper trade. In the former there is a definitely determinable capacity of the plant to use up caustic soda in the manufacture of soap and of chlorine in the manufacture of bleach. In the latter industry, caustic soda and bleach may be similarly used, the one if the soda process for chemical pulp is employed, the other for bleaching the product.

From the standpoint of energy efficiency also, it is evident that brine electrolysis will be used for caustic soda and chlorine as the main products and that hydrogen will remain a by-product. It has been shown that the working voltage of the electrolytic hydrogen-oxygen cells is in the neighbourhood of 2 volts. Now, the decomposition voltage of brine is approximately 2.3 volts and technical cells are usually operated above 3 volts and occasionally as high as 7 volts. The energy efficiency of the cell will therefore vary between 30 and 75 per cent. An example taken from a recent publication<sup>12</sup> concerning this matter will illustrate the effect of this on yield of hydrogen per unit of electrical energy. An alkali chlorine cell operated with a current of 840 amperes at

<sup>12</sup> Horine, *Chem. & Met. Eng.*, 1919, 21, 71, in which article the question of efficiency, energy requirements and costs is treated graphically.

a potential of 4.15 volts. The hydrogen produced per hour amounted to 11.4 cubic feet, or at the rate of  $\frac{11.4 \times 1,000}{840 \times 4.15} = 3.25$

cubic feet per kilowatt hour. In the hydrogen-oxygen cells the corresponding figures are approximately 7-8 cubic feet per hour. The extra energy cost involved in the chlorine cell must be compensated for by the extra worth of the alkali and chlorine produced as contrasted with the potential value of oxygen in the district in which the process is conducted. The choice of process would thereby become a purely economic problem.

The various types of electrolytic alkali-chlorine-hydrogen cells may be divided into three classes which are differentiated from one another by the means taken to minimise interaction between the primary anode and cathode products. The three classes are:

- (a) Diaphragm processes
- (b) Mercury cathode processes
- (c) Bell processes.

In the diaphragm process the anode and cathode are separated by a porous partition generally of moulded asbestos, placed most successfully in close contact with the cathode. The flow of liquor is from anode compartment to cathode compartment in order to prevent flow of hydroxyl ions to the anodic space. The liquor may be drawn off either at the top or bottom of the cells, depending on the relative concentrations of brine and caustic soda when a mixture of these constitutes the cathode liquor. The manifold varieties of these cells does not permit of extended description in this text. The following comprise some of the principal types and the place of their employment:—Griesheim cells, the oldest commercially successful cells, in Bitterfeld and Rheinfelden, Germany; the Hargreaves-Bird at Middlewich, England; the Townsend cell at Niagara Falls; LeSueur's at Rumford, Maine; the Outhenin-Chalandre and Basle cells in France, Switzerland, Italy and Spain; the Billiter-Siemens at Niagara and in Europe; the Billiter-Leyken in Austria; the Finlay in Belfast, Ireland; the Allen-Moore at Portland and Philadelphia; the Nelson in West Virginia and Edgewood, Maryland; the Wheeler in Wisconsin and the Jewell in Chicago.

The mercury process uses anodes of carbon and cathode of

mercury. Sodium amalgam is formed at the cathode, and is then transferred to an adjacent compartment where it reacts with water to form caustic soda and hydrogen, regenerating the mercury. The Castner-Kellner type, an early successful cell, is in operation in England. During the war it was furnishing hydrogen in the compressed state from the plant. Other mercury cells are the Whiting, the Wildermann, the Rhodin and the Solvay-Kellner.

The bell process uses neither mercury nor diaphragm, gravity effecting a partial separation of caustic liquor and brine. The anodes are suspended in bells, having a chlorine gas outlet. The brine is admitted at the anode at a rate such that it flows past the cathode faster than the cathode products can diffuse upwards. In the Aussig, which is the original bell cell, the soda is drawn from the bottom of the tank which may be made to contain as many as twenty-five bells.<sup>13</sup>

The utilisation of the present available hydrogen from such sources is greatly to be desired. Most of it is now wasted. If satisfactory methods are adopted for the exclusion of air and chlorine, the gas obtained is of a high purity. Of these impurities air is probably the more objectionable as chlorine can be readily removed from the gas before being compressed for use, whereas the nitrogen from the air is practically impossible to remove on a technical scale.

<sup>13</sup> Full descriptions of the various cells of all types are to be found in textbooks of Industrial Chemistry, e. g., Rogers, p. 262, 1920 Edition; also see the recent technical literature, e. g., *Chem. Trade J.*, 1920, 66, 464, 491, 521; 1920, 67, 3. *Chem. & Met. Eng.*, 1919, 21, 17, 69, 133, 370, 403, 436. *Trans. Am. Electrochem. Soc.*, April 23, 1921. No. 25.

## Chapter VI.

### Hydrogen From Water.

#### *The Bergius Process.*

This interesting chemical process for the liberation of hydrogen from liquid water has received experimental investigation upon a semi-technical scale. Its translation to the technical unit has, so far as is known, not yet been accomplished, although the process offers very considerable possibilities as a method of cheap hydrogen production.

The process is based on the observation that iron and liquid water readily react in the neighbourhood of 300° C. and that carbon and liquid water react at a somewhat higher temperature. In the temperature interval stated, it is apparent that pressures as great as the vapor pressure of water at such temperatures must be employed. Otherwise, complete vaporisation of the water would ensue. Furthermore, as the critical temperature of water is 365° C. any process of the type named must be conducted below this temperature. The vapor pressures of water in the given region of temperature may be deduced from the following data:—<sup>1</sup>

Temperature ° C.	200	250	300	350
Vapor pressure (atm.)	15.3	39	89	167

The fundamental features of the proposal are disclosed in the patent applications and in a series of articles relative to the process.<sup>2</sup>

With coke in presence of twice its weight of water, containing, as catalytic accelerator, 0.5 per cent of dissolved thallium chloride, ready reaction occurs at 340° C. with production of hydrogen and carbon dioxide.

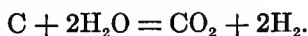

<sup>1</sup> Battelli, *Mem. d. Torino* (2), 43, 63, (1892); Ramsay and Young, *Phil. Trans. A.* 183, 107, (1892).

<sup>2</sup> D. R. P. 254,593/1911; 259,030/1911; 262,831/1912; 277,501/1913. U. S. P. 1,059,817; 1,059,818. *J. Soc. Chem. Ind.*, 1913, 32, 463.

The operating pressure is about 150 atmospheres, the water vapor being removed from the gases by a reflux cooler attached to the exit tube.

With iron and liquid water, reaction starts at temperatures somewhat above 100° C. and is more rapid than with carbon at corresponding temperatures. In this case also, reaction is accelerated by addition of electrolytes such, for example, as ferrous chloride. Metallic couples are in general more reactive than iron itself, the iron-copper couple being especially noted in this regard. Such metallic couples are readily produced by adding to the water an electrolyte such as sodium chloride, introducing along with the iron a plate of copper. The accelerating effect of such arrangements is exemplified by the following table of comparative data:

<i>Reaction Material</i>	<i>T° C.</i>	<i>Hydrogen Gen- erated per Hour</i>
Iron—pure water . . . . .	300	230 cc.
Iron—water—FeCl <sub>2</sub> . . . . .	300	1390 cc.
Iron—water—FeCl <sub>2</sub> —Cu . . .	300	1930 cc.
Iron—water—FeCl <sub>2</sub> —Cu . . .	340	3450 cc.

It will be noted from the last two sets of data that the temperature coefficient of the reaction is low, as one would anticipate from the heterogeneous nature of the reaction. According to Bergius, the reaction with finely divided iron is not merely a surface action but penetrates into the material, a quantitative conversion of the iron to ferrous-ferric oxide resulting.

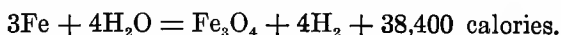

The output per unit of reactant volume should therefore be materially enhanced.

The reaction may be conducted in externally heated steel bombs; when it has once started, the reaction is sufficiently exothermic to be thermally self-sustaining as indicated by the approximate value given in the preceding equation, and further outside heating may be discontinued. The pressure under which the reaction is carried out is also self-produced, first by the



steam and, in the later stages, by the hydrogen, which is only drawn off as the desired operating pressure is exceeded.

In the experimental unit investigated at Hanover, Germany, the reaction mixture was contained in an iron vessel inserted from the bottom in a steel bomb which was closed by a high pressure joint of the LeRossignol type comprising a line joint between a conical plunger and socket of slightly larger angle. The containing vessel served as a protection to the interior of the bomb against attack by steam. The vessels were fitted with a reflux condenser to return evaporated water to the system. The hydrogen was delivered directly to cylinders at a pressure of 150 atmospheres. A cubic foot of useful reaction space generated about 150 cubic feet of hydrogen per hour. Elsewhere, it is stated that a 90 per cent conversion is attained in 4 hours. Hence, a yield of 600 cubic feet per cubic foot of charge represents a conservative estimate of the hydrogen generated.

Discussing the large-scale possibilities of the process Bergius points out that it was possible to obtain in Germany in 1913 steel bombs of the necessary specification as to strength having a reaction space of 35 cubic feet each. With such a unit, a batch yield of 20,000 cubic feet should be possible and a daily output of 100,000 cubic feet. The regeneration of the ferrous-ferric oxide which is formed by the reaction can be effected by heating with carbon to 1,000° C. and this reduction process should be possible with not more than 2 per cent of carbon remaining in the mass on completion of the process.

*Gas Purity.*—A high-grade hydrogen is produced, it is claimed, by this process. Analysis of a 200 litre sample gave the following gas composition:

Hydrogen .....	99.95 %
Carbon monoxide .....	0.001
Saturated hydrocarbons .....	0.042
Unsaturated hydrocarbons .....	0.008

Too much emphasis should not be placed upon such an analysis, since the carbon content of the iron employed is not stated. It is asserted, however, that the carbon and sulphur in the iron are not attacked. It must be borne in mind, however, that the readiness with which carbon reacts is largely a function of its physical

state. It has been noted, in the discussion of the steam-iron process, that, with progressive use of the iron contact mass, the carbon content of the hydrogen increases, due to deposition of active carbon in the iron. It is possible that in the regeneration process necessary in this method of hydrogen production, carbon of a more reactive nature might well become associated with the iron. In such case, an increase of impurities would make itself evident. Owing, however, to the low reaction temperature, it follows that the carbon monoxide percentage would always be low as compared with that of carbon dioxide, owing to the operation of the water-gas reaction,

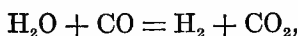

as in the steam-iron and water-gas catalytic processes. Sabatier has shown that a reactive carbon produced catalytically may react with steam to give methane.<sup>3</sup> In this way the saturated hydrocarbons may accumulate in the hydrogen produced.

*General Discussion.*—The general features of the process are such that it should lend itself especially to hydrogen generation where low plant cost, intermittency of use, simplicity of operation and compactness of plant are desirable. Hence it would seem to have distinct possibilities in field work and in the generation of hydrogen at re-charging stations for dirigible airships. The writer has in mind a source of finely divided iron from which it might be possible to obtain the necessary supplies sufficiently cheaply to permit of rejection of the material after it had passed through the oxidation process. The sand used for grinding plate glass contains a marked percentage of finely divided iron which can be extracted from the sand by electro-magnetic means. Such material should be eminently suitable for the Bergius process; and the economy of its recovery from sand would determine the policy adopted in respect to regeneration.

For industrial purposes, the utility of the process appears, as yet, to be limited to such applications as involve the use of highly compressed hydrogen, as, for example, in ammonia synthesis. In this application, moreover, the present intermittent nature of the process constitutes a point of objection. It would undoubtedly entail a rather severe operational and repair charge. It is conceivable, however, that technical development might succeed

<sup>3</sup> French patent 355,900/1905.

in making the process a continuous one. To this end, attention should be given more closely to the original suggestion of Bergius in which carbon was the agent used for decomposition of the water. A form of carbon as reactive as that of iron would have the advantage that there would be no residue resulting and requiring regeneration. On the other hand the hydrogen produced would require purification from carbon dioxide and probably from carbon monoxide for purposes of ammonia synthesis. The balance of advantages against disadvantages offers an attractive field for further investigative work.

### *Field Processes*

Certain processes have been developed for the production of hydrogen in the field using water as the source of hydrogen. The advantage sought in such developments is the lessening of the material weight, per unit of hydrogen produced, required to be transported to the scene of military operations. In such processes the material transported will readily react with water which is generally available in quantity even under service conditions. A number of such materials have now been employed. The alkali metals have not found extended use probably owing to the dangers attending their transport. Use has been made, however, of calcium in the form of its hydride, the process being known as the Hydrolith process. Activated aluminium, or aluminium amalgam reacts readily with water to form hydrogen, and certain aluminium alloys may be substituted for aluminium in the actual process. More recently, lead-magnesium and lead-sodium alloys have been proposed.

### *Metallic Sodium Processes*

Sodium in the form of small pieces was proposed by Foersterling and Phillipp<sup>a</sup> for the production of hydrogen; the violence of the reaction was to be diminished by using water in the form of a fine spray. A later patent to Brindley<sup>b</sup> incorporates the sodium in briquettes compounded of the element with crude oil, kieselguhr, and aluminium or silicon. In this way, hydrogen was to be secured by interaction of sodium with water, and the re-

<sup>a</sup> U. S. P. 888,531/1908.

<sup>b</sup> U. S. P. 909,536/1909.

sulting alkaline liquor was to be used for the generation of hydrogen from the aluminium or silicon (see pp. 131-141). A subsequent patent<sup>6</sup> utilises the same idea, by incorporation in the briquettes of aluminium silicide.

### *The Hydrolith Process*

Instead of employing metallic calcium in suitable form, Jaubert proposed,<sup>7</sup> for purposes of field production of hydrogen, the use of calcium hydride. The earlier French patent deals with the production of this compound from metallic calcium and hydrogen, for example from the waste hydrogen of electrolytic alkali processes. Interaction occurs readily at 600° C. between the metal and hydrogen freed from all traces of oxygen and water vapor. The product reacts with water in the sense of the equation

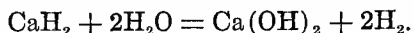

The commercial product, which is a white crystalline powder, containing about 90 per cent calcium hydride together with some nitride and oxide, yields, on treatment with water, upwards of 34,000 cubic feet per ton. Hence, the weight involved in the transportation of material sufficient to produce 1,000 cubic feet of hydrogen is less than 65 pounds. Its applicability for field purposes is thus manifest. Portable units with a total capacity of 700,000 cubic feet of hydrogen have yielded satisfactory results when tested by the French in actual field conditions.

The generators contain calcium hydride in a series of open work trays. Water is admitted from below and the hydrogen passes away from the top of the generator. The reaction is markedly exothermic and moisture is freely carried away by the evolved gas. This moisture is removed in a convenient manner by allowing the hydrogen generated in the first vessel to pass through a second generator also filled with calcium hydride. In this generator the water vapor reacts with calcium hydride liberating an additional quantity of hydrogen. The calcium nitride present as impurity in the reaction material interacts with water to form ammonia. This must be removed before use, the removal being readily accomplished by washing the gas counter-current with water in a scrubber.

<sup>6</sup> U. S. P. 977,442/1910.

<sup>7</sup> F. P. 327,878/1902; B. P. 25,215/1907.

A German modification<sup>8</sup> of the Jaubert process uses water present in the combined state in such substances as gypsum and sodium bicarbonate. In such cases reaction only occurs above 80° C.

#### *Aluminium Amalgam Processes*

Aluminium amalgam reacts with water at ordinary temperatures to yield hydrogen, the aluminium being converted to oxide and the mercury being regenerated in the elementary state



Since the mercury thus formed may amalgamate with further quantities of aluminium and the process be repeated, the mercury acts as a catalytic agent and can be employed in very small amount in comparison with the aluminium brought to reaction. Furthermore, since amalgamation may be produced by direct reaction between aluminium and mercury salts in solution, the mercury required for the process may be supplied in the form of the oxide or a salt, for example, the chloride. As a result, the production of hydrogen in the field by this process can be accomplished with the transportation of little more than the aluminium requisite for the hydrogen. The proportions of the other constituents of the active mixture are of the order of 1-2 per cent by weight of the aluminium. The proposals for the utilisation of the aluminium amalgam process are embodied in a series of patent specifications and in literature references to the same. Mauriceau Beaupré demonstrated<sup>9</sup> that aluminium filings, when immersed in an aqueous solution containing 1-2 per cent of mercuric chloride and 0.5-1 per cent of potassium cyanide, gave a steady evolution of hydrogen. The heat evolved in the reaction caused a rise in temperature of the solution which could, however, be maintained below 70° C. by the addition of cold water. It was shown that, from one kilogram of aluminium, 1,300 litres of hydrogen could be obtained, which is equivalent to 41,000 cubic feet per ton of 2,000 pounds. The apparent density of the material used was low, being approximately 1.36, so that from one litre of aluminium powder 1,700 litres of hydrogen could be produced. The process based on these observations was pat-

<sup>8</sup> D. R. P. 218,257/1908.

<sup>9</sup> *Compt. rend.*, 1908, 147, 810.

ented in 1908,<sup>10</sup> a mixture being employed consisting of aluminium in suitable form, admixed with the stated amounts of mercuric chloride and potassium cyanide. The material is stable in absence of air and moisture. The water required amounts to 200 gallons per ton of mixture.

According to the patent claims<sup>11</sup> of the Chemische Fabrik Griesheim-Elektron, aluminium powder admixed with 1 per cent of mercuric oxide and 1 per cent of sodium hydroxide is equally efficient as a source of hydrogen and is less poisonous than the preparations previously specified. In place of sodium hydroxide, salts having an alkaline reaction may be substituted.<sup>12</sup> The aluminium may be alloyed with other elements notably tin and zinc.<sup>13</sup>

The activity of aluminium alloys has been studied by Kohn Abrest<sup>14</sup> who established the negatively catalytic effect of copper on the process. It was shown that aluminium containing 0.4 per cent copper is not activated by immersion in 1 per cent mercuric chloride solutions. As little as 0.1 per cent copper was found to make the aluminium indifferent towards water.<sup>15</sup> Kohn Abrest also concludes that a mixture of hydroxides of aluminium is produced on reaction with water, the composition varying according to conditions, such as the duration of oxidation, concentration and temperature of the solution.

<sup>10</sup> Fr. pat. 392,725/1908.

<sup>11</sup> B. P. 3,188/1909.

<sup>12</sup> Sarason, B. P. 18,772/1911.

<sup>13</sup> Uyeno, B. P. 11,838/1912.

<sup>14</sup> Bull. Soc. Chim., 1912, 11, 570. J. Chem. Soc., 1912, 102 II, 768.

<sup>15</sup> Compt. rend., 1912, 154, 1,600.

## Chapter VII.

### Hydrogen From Aqueous Alkalis.

#### *The Silicol Process*

Hydrogen for filling military and naval dirigibles or balloons has been extensively produced in recent years by the action of aqueous alkalis, especially sodium hydroxide, on silicon, generally in the form of ferro-silicon. The method is expensive owing to the high cost of raw materials. As the hydrogen may be produced, however, at a very rapid rate, of high purity, in a small, compact and inexpensive plant, with low labor and power requirements, the process is eminently adapted to field purposes and for the inflation of lighter-than-air craft aboard ship at sea.

*Outline of the Process.*—The operations involved in the process are (1) the preparation of the solution of sodium hydroxide (2) the admixture of ferro-silicon with the alkaline solution (3) the separation of water vapor from the hydrogen evolved in the interaction. For these operations, the essential plant required consists of a solution tank in which the sodium hydroxide is dissolved, a generator in which the reaction takes place and a condenser or cooler in which the gas generated is freed from water vapor simultaneously evolved from the reaction mixture owing to the temperature at which the reaction occurs. This temperature of reaction is maintained by means of the two processes occurring, the solution of sodium hydroxide, in which sufficient heat is produced to start the reaction, and the hydrogen generation, which is so strongly exothermic that careful control of the temperature is necessary.

From one gram atom of silicon, four gram atoms of hydrogen may be theoretically produced. Less sodium hydroxide is required than that corresponding to the equation,

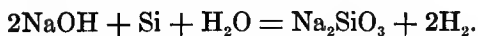

The hydrolytic dissociation of sodium silicate solutions would account for such an observation, or, alternatively, the silicate

formed may be more complex, as for example that given in the equation,

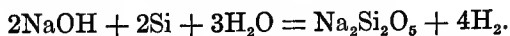

*Literature Résumé.*—The use of silicon with caustic soda solutions for hydrogen generation is claimed in the patent application of the Consortium für Elektrochemische Industrie, G. m. b. H.<sup>1</sup> Milk of lime may be added, it is claimed, to reduce the amount of caustic soda required. A patent<sup>2</sup> to the same firm claims the elimination of the necessity for external heat by preliminary interaction of the sodium hydroxide solution with aluminium or by the production of a hot sodium hydroxide solution, by adding the alkali to the water in the powdered form. This use of silicon and hot soda solutions has been developed mainly in Germany for field purposes under the name of the Schuckert process. French, British and American plants have employed the cheaper ferro-silicon, this development being largely due to Jaubert, the French chemist, and the Société Française L'Oxylithe.<sup>3</sup>

*Experimental Data.*—An intensive study of the governing factors in the operation of the process for military purposes has been made by the U. S. Bureau of Standards. A paper by Weaver<sup>4</sup> presents the method of investigation employed and an analysis of the factors of importance, which will be reproduced briefly in the following. The reaction occurs at the surface of contact of the ferro-silicon and the solution. With the solid completely wetted, the rate of reaction is dependent on the amount of surface of the ferro-silicon, the composition of the liquid and the solid phase, and on the temperature. In addition to rate of reaction, the hydrogen yield from unit weight of silicon is of first importance.

The yield of hydrogen in practice is by no means independent of the silicon content of the ferro-silicon as it should be upon theoretical grounds. Thus, as is shown in the appended figure, Fig. XIII, the hydrogen yield under the conditions most favorable for obtaining a complete reaction only approaches theoretic-

<sup>1</sup> B. P. 21,032/1909.

<sup>2</sup> B. P. 11,640/1911.

<sup>3</sup> Jaubert, F. P., 430,302/1910; B. P. 17,589/1911; F. P., 433,400/1913; B. P. 7,494/1913. U. S. P. 1,037,919.

<sup>4</sup> J. Ind. Eng. Chem., 1920, 12, 232.



cal efficiency with ferro-silicon containing upwards of 80 per cent silicon. Furthermore, the initial rate of reaction attains a maximum with ferro-silicon of about 90 per cent silicon content. Also, the rate of evolution of hydrogen expressed as a percentage of the initial rate falls away linearly with increasing percentage of total silicon consumed in a given trial. All these experimental facts point to the advantage of employing a ferro-silicon containing in the neighbourhood of 90 per cent silicon.

Ferro-silicon of the same composition gives the same total

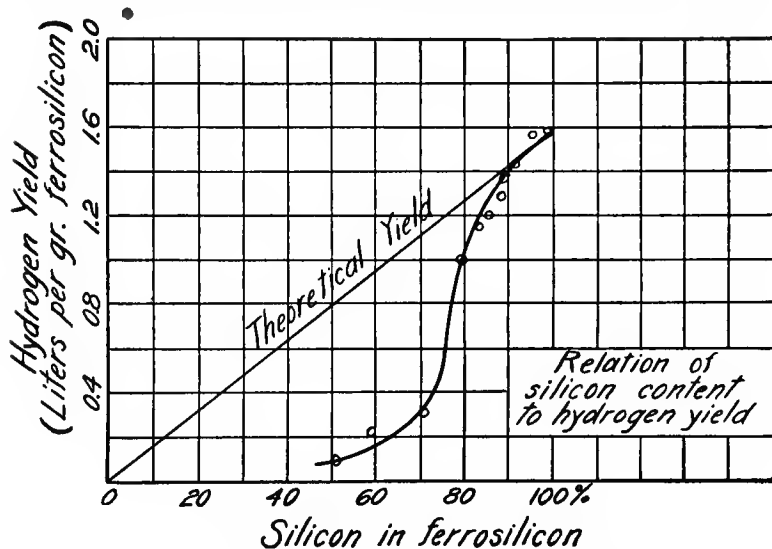

FIG. XIII. Relation of Silicon content to Hydrogen Yield.

yield of hydrogen under the most favorable circumstances independently of its state of division. A material of finer subdivision, however, gives a more rapid evolution of hydrogen in the earlier stages of the process than the coarser material.

The concentration of the sodium hydroxide solution is a very important factor. With increasing concentration of solution the initial rate of reaction increases steadily. The effect of dilution, however, is dependent on the amount of silicon which has already been dissolved in the soda solution. Thus, the rate of solution of ferro-silicon in a 20 per cent sodium hydroxide solution containing no dissolved silicon is quite different from that in a solution which is 20 per cent with regard to free alkali but

which also contains sodium silicate from previous reaction. Dissolved silicon depresses the rate of reaction.

The total yield is also affected by the concentration of alkali. With solutions which are too dilute, the yield of hydrogen is poor. Also, there is a greater tendency to "frothing." The frothing may be so great as to carry liquid out of the generator into the pipes and valve systems causing blocks and stoppages. Solutions of high alkali concentrations, on the other hand, while giving rapid gas evolution, produce highly viscous fluids which may cause considerable trouble in removal from the generator system and result also in poor hydrogen yields, due to incomplete reaction of the ferro-silicon in the viscous mass.

The following table given by Teed<sup>5</sup> represents results obtained with a ferro-silicon containing 92 per cent silicon and a 98 per cent sodium hydroxide as raw materials. The figures include data from solutions more dilute and more concentrated than the 25 per cent solution, which is the concentration obtaining in average practice.

<i>Concentration of Sodium Hydroxide Solution</i>	<i>Ratio of Silicon to Sodium Hydroxide</i>	<i>Hydrogen Yield in Cubic Feet per Lb. of Silicol</i>
10 per cent	1 : 0.745	13.62
10	1 : 1.065	14.30
10	1 : 1.480	15.36
10	1 : 3.20	16.80
30	1 : 0.852	19.35
30	1 : 2.13	23.90
30	1 : 3.19	23.58
40	1 : 1.58	24.10
40	1 : 3.19	24.50

The hydrogen yield is expressed at a pressure of 30 inches of mercury and a temperature of 60° F. The maximum possible yield under these conditions would be 25.4 cubic feet per pound of silicol of the stated purity.

Temperature increases the rate of hydrogen evolution. An increase of reaction temperature from 100 to 110° C. increases

<sup>5</sup> *Chemistry and Manufacture of Hydrogen*, Arnold, 1919, p. 53.

the reaction velocity by 50 per cent. At 90° C. the rate is approximately 68 per cent of that at 100° C. With a reaction temperature in this neighbourhood it is obvious that the hydrogen evolved will contain a considerable concentration of water vapor corresponding with the vapor pressure of the solution at the given temperature. It is this factor of water evaporation which necessitates the employment of alkali solutions of medium concentrations and the addition of water to cool and dilute the solution. This factor of vaporisation and the heat required to effect

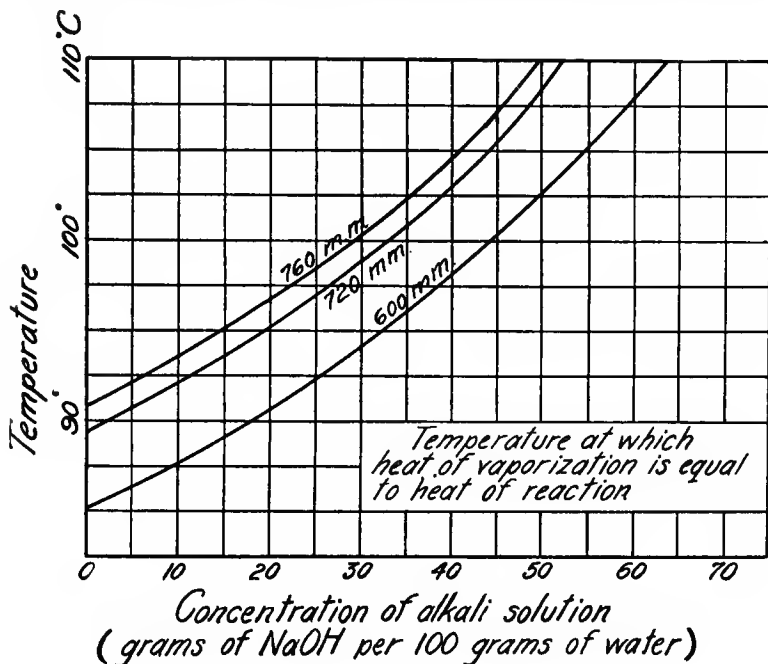

FIG. XIV. Heat of Vaporisation Data.

the same constitutes one of the important safeguards in this process, as preventing the attainment of excessive temperatures. Ample body of solution should always be assured. The accompanying diagram, Fig. XIV shows the temperature at which heat of vaporisation is equal to heat of reaction for various barometric pressures and different alkali concentrations, the heat of reaction being assumed to be 49 Kilogram calories per gram molecule of silicon dissolved in the alkali.

The application of such experimental data to the actual working operation has been illustrated by Weaver \* in a series of generator problems. The accompanying figure, Fig. XV, collects the

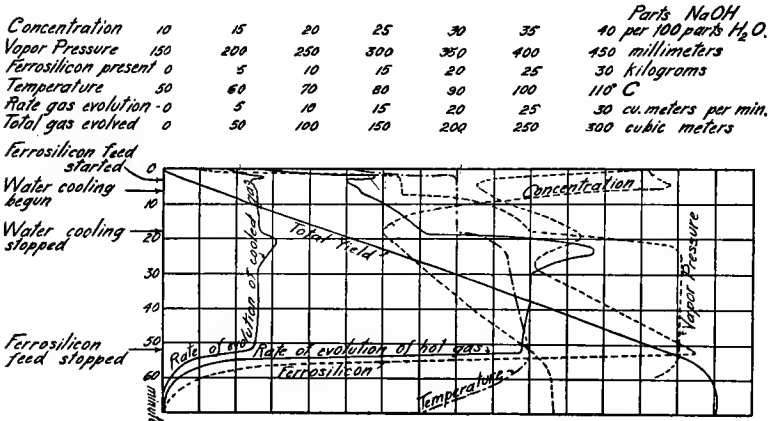

FIG. XV. Graphical Representation of Generator Problem.

results of such an investigation in graphical form. The data apply to a generator in the form of an unprotected cylindrical tank 6 feet 6 inches high and 6 feet in diameter, made of one-quarter inch boiler plate; the solution tank, having about one-fourth the capacity of the generator, is assumed to have a heat capacity including stirring machinery equal to one-half of that of the generator. Air temperature is assumed to be 20° C., supply water to be at 18° C., and barometric pressure 740 mm. of mercury. The wind velocity is 10 miles per hour.

The charge is 363 kg. of ferro-silicon, 88 per cent Si, of the fineness given by the following data:

	Per Cent
Rejected by 20 mesh .....	10
Through 20, on 30 .....	20
"    30, " 40 .....	10
"    40, " 60 .....	10
"    50, " 80 .....	15
"    80, " 100 .....	15
Through 100 .....	20

Total ..... 100 per cent

\* Loc. cit. 235-237.

Generation is started with a 30 per cent solution of sodium hydroxide made by dissolving 290 kg. of alkali in 677 kg. of water. In order to heat the solution more quickly only half the solution and 75 pounds of ferro-silicon are introduced into the generator. When the temperature reaches 90° C. the ferro-silicon feed is started at the uniform rate of 15 pounds per minute and continued until all the charge has been added. As soon as the ferro-silicon feed is started, the remainder of the solution is run into the generator at such a rate as to keep the temperature constant. When all the solution has been added the constant temperature is maintained by the addition of cold water until the solution contains about 20 per cent of sodium hydroxide. The water is then stopped and no further effort made to control the reaction.

For the method of obtaining such a chart and for the data which are employed in computing the same, the original article should be consulted. A discussion of the accuracy and significance of such generator calculations is also given.

Weaver concludes that in spite of the many conditions affecting the rate of reaction of a given amount of ferro-silicon, the rate of evolution of gas over the major part of a generator run is primarily a function of the rate of addition of ferro-silicon. With varying conditions of temperature and concentration of solution, provided these are reasonably constant, the ferro-silicon feed, if regular, will cause accumulation of material in the generator until the amount of reacting surface is such that the rate of solution will approximate the rate of addition. Conditions must be so chosen that equilibrium is quickly reached without generating gas at an excessive rate; there should be no sudden variations of generator conditions, particularly of temperature; the reaction should also come quickly to an end after the ferro-silicon is all exhausted. The procedure, outlined in the generator problem cited, as to the start of the reaction is probably the best for bringing the generator temperature rapidly to the working equilibrium. Fig. XIV, shows the temperatures at which the heat of vaporisation of the water carried away by the gas at various concentrations of alkali will be equal to the heat of reaction. These represent the maximum temperatures beyond

which the generator could not rise if there were no other heat losses than through evaporation. In actual practice these temperatures will be approached more or less closely depending on the magnitude of the other heat losses, which vary with the atmospheric conditions and with the position of a plant, whether housed or in the field. The initial charge of ferro-silicon added to the solution or portion thereof should be of such a size that when the desired generator temperature is reached the rate of reaction will be the desired average for the run. If the temperature of the alkali be initially low it is advisable to add the necessary ferro-silicon in the finely divided, more rapidly reacting form. Aluminium is sometimes used as a substitute for such finely powdered or high grade ferro-silicon to attain the initial reaction temperature.

Weaver shows that, for a 20 per cent alkali solution the yield of hydrogen during a one hour run increases with increasing ratio of sodium hydroxide to silicon and attains a figure beyond which increase of alkali is of negligible effect. From such data, assuming cost figures of 12.5¢ and 6¢ per lb. for ferro-silicon and sodium hydroxide respectively, it is calculated that the greatest economy is obtained by using about seven-tenths as much sodium hydroxide as silicon present in the material. Use of equal weights of both, however, decreases the danger of obtaining viscous solutions at the end of a run. On the other hand, according to Weaver, it costs more to produce a given volume of hydrogen when too little sodium hydroxide is used, only because ferro-silicon remains unacted upon at the end of the run. The amount of material wasted decreases very rapidly when generation is permitted to proceed for a short time after the material is added; hence when haste is not an important object greater economy could no doubt be secured by using a still smaller proportion of alkali. These conclusions of Weaver conflict with those of Teed who advises a ratio of silicon to sodium hydroxide as high as 1 to 1.72.<sup>7</sup> American practice represents the conclusions of more recent work and is certainly the more economical.

The patent to the Compagnie Generale d' Electrochimie de Bozel<sup>8</sup> suggests economy in the matter of sodium hydroxide by the use of a lime-sodium carbonate mixture. As an example, a

<sup>7</sup> Cf. also *British Admiralty Hydrogen Manual*, Vol. I, p. 137.

<sup>8</sup> B. P. 127,018/1917.

mixture of silicon 20 parts, lime 80 parts, sodium carbonate 10 parts, and water 225 parts is cited. The matter of using lime has been investigated experimentally by Gordon.<sup>9</sup> He found that it was impracticable to substitute lime for sodium hydroxide entirely, as the rate of reaction is so slow due to the low alkali concentration of the saturated solution of lime. It was also shown that the recovery of sodium hydroxide from generator sludge by addition of lime was impracticable as, even with careful treatment, it is difficult to recover even 50 per cent of the original alkali. Owing to the voluminous nature of the precipitate of calcium silicate, the recovery of the alkali would require the use of filter presses. For operations in the field, this necessity would diminish the value of the process with respect to smallness and compactness of plant. On the large scale, with stationary plant and large alkali consumption, use of a filter press would undoubtedly effect economies. Using lime and sodium carbonate in place of sodium hydroxide was found by Gordon to be possible. With even a larger excess of alkali (as sodium carbonate-lime), however, the yield of hydrogen was only 89 per cent of that from sodium hydroxide solutions in excess. Also, the effect of reducing the ratio of alkali to ferro-silicon is very marked and is much greater than when pure sodium hydroxide is used. Rate of hydrogen evolution was also slower and a large excess of lime proved to be a marked detriment. A solution equivalent to 12.5 per cent sodium hydroxide was somewhat better than a 10 per cent solution and very considerably better than a 20 per cent solution.

*Plant Details.*—Plants generating between 1,500 and 60,000 cubic feet of hydrogen per hour have been built and operated in the last few years in the various allied countries. While alike in essentials the various sizes differ in detail, for example, in condenser equipment, source of necessary power, mechanism of silicon feed and of temperature control.

The necessary parts in all plants include the following:

- (1) A caustic soda vat, in which the alkali is dissolved, fitted with stirring mechanism.
- (2) A generating tank, in which the reaction occurs, fitted with stirring mechanism.

<sup>9</sup> U. S. National Advisory Committee for Aeronautics, Report No. 40.

(3) A hopper, to hold the powdered ferro-silicon, and fitted with suitable adjustable feeding device.

(4) A cooling chamber in which moisture is separated from the hot hydrogen.

(5) A condenser system in which the gas is washed and cooled.

(6) A power plant to operate stirrers, pumps, etc. In the smaller plants the necessary power is supplied by hand.

*Generators.*—These are usually cylindrical tanks but in the smaller units may be rectangular. A tank having a hydrogen capacity of 10,000 cubic feet per hour will average about 5 feet in diameter by 9 feet deep or a wider, shallower cylindrical vessel of the same cubical capacity. The dimensions of a unit producing 60,000 cubic feet per hour will be as much as 9 feet in diameter and 12 feet high or its equivalent in cubic capacity. The tanks should be of commercial sheet steel of suitable size to stand the necessary flanging, should be easily and readily welded. All the tank seams should be welded. On a flange at the top of the generating tank, a cover held in place by nuts and bolts is made to give a gas-tight vessel with suitable gasket between cover and flange. Through the cover passes a stirring gear for the generator, driven by bevel gearing from a horizontal shaft, so driven as to give 60 revolutions per minute to the vertical shaft. From the base of the tank, the sludge is discharged through a 4 inch drain fitted with a suitable gate valve. A cold water spray for diluting the contents of the generator and regulating its temperature is also provided.

*The Ferro-Silicon Hopper.*—This varies in different plants. In some the hopper is provided at the top with a self-opening man hole of gas-tight construction and an adjustable feeding mechanism to feed dry silicol, the feed being variable between all ranges of feed from zero to maximum capacity of the generator. This feed may be hand driven or mechanical. The British Admiralty adopted and standardised a wet feed process. The ferro-silicon, in suspension in water, and so maintained by mechanical agitation, is fed into the generator through a delivery pipe having a jet feed the size of which varies with the capacity of the plant. For a plant producing 2,500 cubic feet per hour two feeds, with jets,  $\frac{1}{4}$ " and  $\frac{5}{16}$ " are employed. For a unit with a capacity of



60,000 cubic feet per hour, the maximum size of jet is  $\frac{3}{4}$ ". The amount of silicol introduced through the jets is determined by the height of liquid above the jet and the pressure of gas in the generator. Both must be kept under observation and control to ensure steady generation. Wet feeds are being studied in this country at the present time.

*Soda Vats.*—In modern units these are covered as with the generator and provided with similar stirring gear to facilitate rapid solution of the alkali. They are approximately about half the cubic capacity of the generator.

*Condenser Equipment.*—For the separation of water vapor, use is made both of water cooling and air cooling. In large stationary units coke scrubbers of the usual type may be used. For a 20,000 cubic feet per hour unit a coke scrubber 5 feet in diameter by 12 feet high is adequate. In portable plants, the coke may be replaced by a series of grids of light sheet steel, nickel-plated for protection against corrosion. To economise water in portable plants, a supplementary water cooler is provided in which the water is allowed to flow over nickel plated cooling grids counter current to a supply of air coming from a fan. Single stage circulating pumps of the centrifugal type are also provided for water circulation.

To free the hydrogen still further from water vapor and also from entrained moisture, the gas is finally made to travel at high speed through a series of tubes or passages having abrupt directional changes. In this way hydrogen of greater lifting power for balloons is secured.

*Power Equipment.*—For small units, hand power alone is necessary. For larger units, gasolene or oil engines or electric drive has been provided. A 5 h. p. oil engine is adequate for a 10,000 cubic feet plant of the stationary type. For a unit of hourly capacity equal to 20,000 cubic feet, fitted with circulatory pumps, air fans, etc., a 20 H. P. engine or motor of similar capacity has been specified.

*Operational Details.*—Since, at starting up, the generator is filled with air the first gas evolved should be blown to waste. If the plant be operated in conjunction with a gas holder the elim-

ination of air is best accomplished by closing all valves but that to the sludge discharge prior to feeding the sodium hydroxide solution to the generator. The whole system should then be swept out backwards from the gas holder through to the sludge drain. According to Weaver,<sup>10</sup> with a regulated temperature of sodium hydroxide solution and fixed rate of silicol feed it is possible to determine the length of time required for purging the generator and condenser equipment by observing the temperature rise in the generator. Data are given to show the method of computation. It is possible to check the length of time necessary for purging of the system by observation of the end of the hydrogen pipe when the air has been practically freed of air. The difference in light refraction of hydrogen and air makes the escaping hydrogen very noticeable to a trained observer.

To prevent foaming in the generator tank and consequent entrainment of reacting materials with the gas, use may be made of a mineral grease. In large plants this is, however, generally unnecessary. A charge of mineral grease equivalent to 1 lb. per 1,000 cubic feet of gas generated should be sufficient. It is conveniently introduced through the soda vat but may be introduced through a special device in the generator cover. It should be emphasized that non-saponifiable greases be used.

In the plant all lead jointings should be eliminated owing to the danger of an explosive reaction with silicon

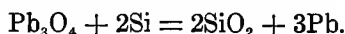

Separate storage for ferro-silicon and sodium hydroxide is especially desirable. Moist mixtures of the two solids react most energetically and may become incandescent. Furthermore, procedure should be such that it is next to impossible for the caustic liquor to reach a ferro-silicon mass. The heat of reaction between the two is so great that the ferro-silicon must always be added to excess liquor, never the reverse, liquor to excess ferro-silicon.

On completion of the reaction process, the sludge should be immediately discharged, to obviate solidification in the generator. Hot water, for washing out the sludge, diminishes the tendency to solidification. The generator should be thoroughly washed out with fresh water after each run is made.

<sup>10</sup> Loc. cit.

*Ferro-Silicon Specifications.*—From the discussion previously given it is apparent that a ferro-silicon containing not less than 80 per cent silicon should be specified. The residual material is principally iron and aluminium with small amounts of calcium, carbon, phosphorus and arsenic. Iron is generally assumed to be an inert constituent. By some it is regarded as a catalytic accelerator of the reaction process. Others have claimed that iron enters into the reaction, yielding hydrogen, but this is doubtful. Metallic aluminium is a useful constituent of the alloy since it reacts with the alkali to yield hydrogen. Phosphorus, arsenic and calcium carbide should be maintained at as low a figure as possible, since they give rise to acetylene, phosphine and arsine in the hydrogen produced, which gases have a harmful effect on the balloon fabric as well as being poisonous and liable to promote inflammability in the gas.

A typical analysis of a high grade ferro-silicon with minimum and maximum specifications as required by the British Admiralty is appended.

Silicon . . . . .	90.0 per cent	Not less than 85 per cent		
Iron . . . . .	4.5 " "	_____		
Aluminium . . . . .	4.6 " "	_____		
Carbon (Free) ..	0.2 " "	Not more than 1.0 per cent		
Calcium . . . . .	0.2 " "	Not more than 0.25 " "		
As } . . . . .	0.02 " "	Not more than 0.05 " "		
P }				
Moisture . . . . .	0.10 " "	_____		
Undetermined ..	0.38 " "	_____		

The American standard is 80-85% Si and to pass through a 30 mesh sieve.

*Composition of the Gas.*—The hydrogen produced is of very high purity, the main impurities being phosphine, arsine and sulphuretted hydrogen which result from interaction of impurities in the ferro-silicon with the alkaline liquor. The concentration of these gases is extremely small, however, the phosphine and arsine not generally exceeding 0.01 per cent. Even these concentrations, however, tend to impair balloon fabric and attack copper or brass when oxygen is present. Aluminium and zinc appear to be immune from such corrosive action, so that, taken in con-

junction with its lightness, aluminium constitutes an ideal metal for dirigible structures. According to Jaubert<sup>11</sup> preliminary treatment of ferro-silicon with an aqueous liquid, e. g., water, tends to decompose phosphides and so to eliminate phosphine from the hydrogen produced.

*Chemical Composition of the Sludge and Its Disposal.*—The sludge consists of a solution, containing, in the main, sodium silicate, which, owing to hydrolysis, is strongly alkaline and liable to form a gelatinous mass due to hydrated silicic acid. In addition, there are present the original impurities of the sodium hydroxide, chiefly sodium carbonate, also those from the ferro-silicon, principally iron, iron oxide and sodium aluminate. It may be possible to work up such material in small quantities for silicate of soda. Frequently, however, it constitutes a waste product difficult to dispose of owing to a relatively high alkali concentration. In washing away to sewage it should be very freely diluted with water. Non-caustic residues obtained by using a high concentration alkali at the start can be used to a certain extent in the dyeing and bleaching industry. Caustic residues have a potential value in oil refining to produce a neutral oil, the foots, with their content of sodium silicate, being the basis for cheap soaps.

*General Remarks on the Efficiency and the Economy of the Process.*—The outstanding feature of the process as to efficiency is the rapidity with which hydrogen can be generated from a restricted space and in a brief period of time from starting up. This rapidity of generation and smallness of plant required, give the process a considerable importance in the field of aeronautics and especially in military and naval aeronautics where intermittent working is frequent and great speed of production often essential. The low capital cost of a ferro-silicon plant is an item in favour of the process when the plant is only to be used intermittently. Indeed, the plant cost in this process forms a negligible item in comparison with the direct cost of production. A unit having a capacity of 20,000 cubic feet per hour can be purchased for \$12,000, while it may be housed for approximately one-quarter of this cost, or an extra investment of \$3,000. It is not possible to charge this investment on the basis of hydrogen pro-

<sup>11</sup> B. P. 147,519/1920.

duced since such a plant is generally only run intermittently. Reckoning interest, depreciation, taxes and insurance at 25%, however, this amounts to a daily capital charge of less than \$11.

The direct cost as to raw materials is in sharp contrast to this. Since the minimum requirements of ferro-silicon and caustic soda will be 50 lbs. of each respectively and since average trade prices for these materials when consumed in quantity are not less than \$160 and \$40 per ton respectively, it follows that the ingredients costs per 1,000 cubic feet of gas are at least:

$$\begin{aligned} 50 \text{ lbs. (85\% ferro-silicon)} &= \$4.00 \\ 50 \text{ lbs. caustic soda} &= \$1.00 \end{aligned}$$

or a total ingredients cost not less than \$5 per 1,000 cubic feet of gas. Furthermore, it must be remembered that if continuous supplies of hydrogen are to be ensured these expensive raw materials must be stored to some extent. The outlay involved in such a procedure must be added to the capital cost of the plant.

It is obvious, therefore, why, even in plants of moderate size, devoted to the generation of hydrogen for aeronautical purposes, the recent tendency has been towards utilising one or other of the alternative methods of hydrogen generation for the normal requirements of the station, reserving the silicol plant for emergency purposes. For small and isolated air stations the process will continue to find application because of the simplicity of procedure and the economy of plant outlay.<sup>12</sup>

#### *Aluminium-Sodium Hydroxide Process.*

The procedure detailed in reference to the ferro-silicon process is adapted to the preparation of hydrogen by the interaction of aluminium and aqueous sodium hydroxide. The reaction may be represented by means of the equation

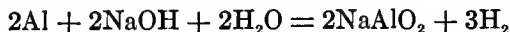

although there is the possibility of production of aluminates of the general type  $\text{Na}_3\text{AlO}_3$ , as exemplified in the equation

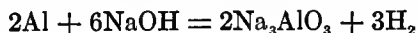

In either case, the hydrogen yield per unit of aluminium is the same and amounts theoretically to upwards of 45,000 cubic feet

<sup>12</sup> For further discussion of this subject see Teed, *Engineering*, 1920, 109, 811.

of hydrogen per ton of aluminium. The sodium hydroxide required in practice corresponds more closely to that required by the first equation. Actual large scale experiments have shown yields of hydrogen equivalent to 44,000 cubic feet per ton of aluminium and 28,000 cubic feet per ton of 90% sodium hydroxide. This latter figure could doubtless be modified by extended experiment, along the line of Weaver's investigations with ferro-silicon, to give a higher yield of hydrogen per unit of alkali used.

The aluminium employed should be in the form of clippings, foil or granules. Massive metal is but slowly acted upon. Alkali of the strength used in the silicol process is also applicable in this process.

The sludge produced is more liquid than the ferro-silicon sludge and shows less tendency towards gelatinisation. It is however also strongly alkaline since the aluminates are markedly hydrolysed. It should be possible to convert this sludge into marketable products more easily than in the case of the silicol sludge since the alumina obtained by acidification of the solution should be suitable for use in the preparation of aluminium metal once more.

The process was used by the Russians in the Russo-Japanese war of 1904; in the recent war, the reaction was occasionally made use of to start the reaction in the silicol plants, since the reaction with aluminium is more energetic at lower reaction temperatures than can be used for the ferro-silicon process.

The apparatus employed in the silicol process is directly applicable to this process. The two processes are so alike that the question of choice, once the procedure had become standardised in each case, would become an economic one, dependent on the relative costs of ferro-silicon and aluminium on the one hand and on the potential market for the alkaline residue on the other hand.

## Chapter VIII.

### Hydrogen From Hydrocarbons.

The hydrogen produced by the various methods detailed in the preceding chapters is obtained from water, which is the cheapest and most available supply of combined hydrogen. Next in availability and the only other naturally occurring source of hydrogen of considerable technical importance is the family of hydrocarbons. These hydrocarbons occur in nature in the form of a complex mixture known by the generic term of petroleum, generally in association with the mixture of gaseous hydrocarbons known as natural gas. The main constituents of both petroleum and natural gas are carbon and hydrogen, and varied attempts have been made to obtain from them hydrogen, on the one hand, and either carbon or carbon-containing gases on the other. The stimulus to such investigations has been twofold; for, aside from the increasing industrial importance of hydrogen, the production of carbon in finely divided condition in a form suitable for use as a black pigment has offered great possibilities of profitable application. The present methods of producing carbon black, by the incomplete combustion of hydrocarbons, are expensive and wasteful of a valuable raw material. Methods of producing carbon black having the necessary properties of such material, with simultaneous production of hydrogen, would inevitably lead to the supersession of the old lamp black industry.

The process which is utilised for the simultaneous production of carbon and hydrogen from hydrocarbons is in all cases one of thermal decomposition. The procedure varies from case to case according to the nature and thermal properties of the hydrocarbon to be utilised.

The data on the stability of methane have been critically examined by Lewis and Randall<sup>1</sup> who concluded that in this case they were sufficiently reliable to warrant the calculation of free energy data. From the specific heats of hydrogen and methane

<sup>1</sup> *J. Am. Chem. Soc.*, 1915, 37, 467.

and the material relative to heats of combustion of these gases it was deduced that the heat of formation of methane from its elements at 291° Abs. was accompanied by the evolution of 18,300 calories, and at 0° Abs. 16,300 calories. The free energy equation hence derived was

$$\Delta F^\circ = -RT \log_e K = -RT \log_e \frac{P_{\text{CH}_4}}{(P_{\text{H}_2})^2} = -16300 + 6.6T \log_e T + 0.0008T^2 - 0.0000002T^3 - 26.0T.$$

The value for K the equilibrium constant thus derived shows good agreement with the following experimentally determined values of Mayer and Altmayer<sup>2</sup> and Pring and Fairlie.<sup>3</sup> It is

T° Abs.	823	1473	1573	1673
K =	0.64	0.00244	0.0015	0.0009

evident from these figures that at ordinary temperatures methane is the stable substance; the higher the temperature, however, the greater the equilibrium concentration of hydrogen and the less the value for K.

This conclusion may be generalised by stating that high temperatures favour the thermal decomposition of exothermic hydrocarbons to yield carbon and hydrogen.

In the absence of similar critical data relative to acetylene, use may be made of the Nernst approximation formula. The exact magnitude of the thermal change accompanying the reaction is in doubt but is of the order indicated in the equation

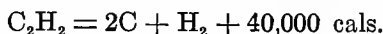

Now, according to the Nernst approximation formula:

$$\log K = \log \frac{P_{\text{C}_2\text{H}_2}}{P_{\text{H}_2}} = -\frac{Q}{4.57T} + \sum n.1.75 \log T + \sum nC$$

where log K applies to the partial pressures of the gas expressed in atmospheres at a total pressure of one atmosphere; Q represents the heat of the reaction at ordinary temperatures;

<sup>2</sup> *Ber.*, 1907, 40, 2,134.

<sup>3</sup> *J. Chem. Soc.*, 1912, 101, 91.



$\Sigma n$  = the algebraic summation of the number of mols of gaseous participants in the reaction, reactants counted positive resultants negative. In this case  $\Sigma n = 1 - 1 = 0$ ; hence the 2nd term falls away.

$\Sigma nC$  = the algebraic summation of the chemical constants of the reacting gases, multiplied in each case by the number of molecules taking part in the reaction. In this case  $C_{H_2} = 1.6$ ;  $C_{C_2H_2} = 3.2$ . Hence  $\Sigma nC = 1 \times 3.2 - 1 \times 1.6 = 1.6$ .<sup>4</sup>

The equation therefore becomes:

$$\log K = \log \frac{P(C_2H_2)}{P_{H_2}} = \log \frac{1-x}{x} = -\frac{40,000}{4.57 T} + 1.6.$$

From this equation the following values result for  $(1 - x)$ , the amount of undecomposed acetylene in equilibrium with hydrogen and carbon at the given absolute temperatures

T =	300°	1,000°	2,000°	3,000°
1 - x	10 <sup>-26</sup>	10 <sup>-6</sup>	0.16	4.8

It will be seen that over all the ordinary temperature range acetylene may be practically quantitatively decomposed. Only at temperatures attainable by the electric arc is acetylene stable in marked quantity.

In a similar manner it can be established that, of the saturated paraffins, methane, ethane, propane, the former is the most stable within the temperature range below 1,000° C. although it has the smallest heat of formation. This would suggest that carbon and hydrogen could be more easily prepared by thermal decomposition of the more complex paraffins than from methane. It must be observed, however, that the thermal degradation process is not the simple process indicated by the equilibrium equation

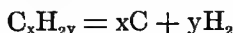

<sup>4</sup>Tables of values for the chemical constants of different common gases are to be found in Lewis, "System of Physical Chemistry," Vol. II, p. 75, 1919 Edition. For calculations involved in the study of hydrogen production the following comprise a useful selection of such constants:— $H_2 = 1.6$ ;  $CH_4 = 2.8$ ;  $O_2 = 2.8$ ;  $CO = 3.5$ ;  $H_2S = 3.0$ ;  $SO_2 = 3.3$ ;  $CO_2 = 3.2$ ;  $CS_2 = 3.1$ ;  $H_2O = 3.6$ ;  $C_2H_2 = 3.2$ . When an actual value for C is not available it is evident from the majority of the examples cited that the value 3.0 can be used as a first approximation for the unknown chemical constants.

but that the decomposition proceeds in stages. As methane is undoubtedly one of these stages, the more complex paraffins should require as high a temperature as methane for complete decomposition. Furthermore, it must be borne in mind that methane is an extremely stable hydrocarbon, the velocity of decomposition being abnormally slow until temperatures in the neighbourhood of  $1,000^{\circ}$  C. are reached. Even with catalytic agents, at this temperature, decomposition is not particularly rapid.

Alternative to processes of thermal decomposition the production of hydrogen by interaction of hydrocarbons with steam has also been attempted. The procedure may be explained by reference to the case of methane. Interaction of methane and steam yields a mixture of hydrogen and oxides of carbon as represented in the equations

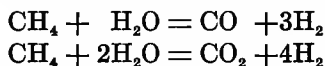

These reactions are reversible, the reverse, or methane forming, reaction being utilised in other circumstances (see Chapter X) for the removal of carbon monoxide and carbon dioxide from hydrogen. The process is one of catalytic hydrogenation in the presence of reduced nickel or other suitable catalyst at temperatures within the range of  $200\text{--}400^{\circ}$  C. At higher temperatures and especially in the presence of excess of steam, the reaction proceeds in the direction of hydrocarbon decomposition. The equilibria prevailing in these two reactions are calculable from thermal data by means of the Nernst approximation formula. In the reaction:

$$\begin{aligned}\text{CO} + 3\text{H}_2 &= \text{CH}_4 + \text{H}_2\text{O} + Q \text{ calories,} \\ Q &= -26,300 + 18,400 + 57,600 = 49,700 \text{ cal.} \\ \Sigma n &= 1 + 3 - 1 - 1 = 2 \\ \Sigma nC &= 3.5 + 3(1.6) - 2.8 - 3.6 = 1.9\end{aligned}$$

Hence

$$\log K_p = \log \frac{p_{\text{CO}} \times p_{(\text{H}_2)}^2}{p_{\text{CH}_4} \times p_{\text{H}_2\text{O}}} = -\frac{49,700}{4.571 T} + 3.5 \log T + 1.9,$$

the partial pressures of the several gases being expressed in atmospheres. From the equation, the following values for  $K_p$  at different temperatures have been calculated

T° Abs. =	500	800	1,000	1,500
K <sub>p</sub> =	4 × 10 <sup>-11</sup>	0.03	35	6 × 10 <sup>5</sup>

In a similar manner it can be shown for the reaction

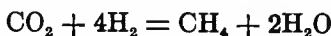

that

$$\log k_p = \log \frac{p_{\text{CO}_2} \times p_{\text{H}_2}^4}{p_{\text{CH}_4} \times p_{(\text{H}_2\text{O})}^2} = -\frac{4.571 T}{39,300} + 3.5 \log T - 0.4$$

whence the following values are calculable:

T° Abs. =	500	800	1,000	1,500
K <sub>p</sub> =	7 × 10 <sup>-9</sup>	0.1	31.7	10 <sup>5</sup>

Both reactions therefore share a common feature. The equilibrium position is in each case very sensitive to temperature. Below 500° Abs. the equilibrium is in each case practically quantitatively on the methane side. Above this temperature the equilibrium position tends more and more to the side of carbon monoxide or carbon dioxide and hydrogen. A knowledge of these equilibria demonstrate why the methanation process is to be conducted in the temperature region of 200°-300° C. and why, for the interaction of methane and water to yield hydrogen, high reaction temperatures are essential.

One further possibility in the production of hydrogen from hydrocarbons may here be mentioned although so far as is known it has not been attempted technically. Under the influence of high temperatures methane should react with carbon dioxide to yield hydrogen and carbon monoxide according to the equation

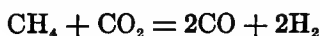

The equilibrium in this reaction is also of the same nature as those immediately preceding. Application of the Nernst approximation formula gives:

$$2\text{CO} + 2\text{H}_2 = \text{CH}_4 + \text{CO}_2 + 60,100 \text{ cal.}$$

Hence

$$\log K_p = \log \frac{p_{\text{CO}}^2 \times p_{\text{H}_2}^2}{p_{\text{CH}_4} \times p_{\text{CO}_2}} = -\frac{60,100}{4.571 T} + 3.5 \log T + 4.2$$

which equation gives the following calculated values for  $K_p$  at different absolute temperatures:

$T^\circ$ Abs. =	500	800	1,000	1,500
$K_p$ =	$2 \times 10^{-13}$	0.008	0.4	$3.5 \times 10^6$

It will be seen that, in this case also, the gradient of the equilibrium with temperature is steep. Also, it may be noted that a somewhat higher temperature would be necessary in this case, in order that the methane decomposition with carbon dioxide be carried to the same degree of completeness as is attainable using steam.

In reference to all three reactions it must be observed that, once the hydrocarbon is decomposed and hydrogen and carbon oxides produced, these reaction products interact among themselves in a manner dependent on the water-gas equilibrium

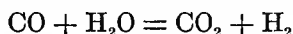

which at any given temperature will determine the relative amounts of these substances present in equilibrium. (See Chapter III.)

*Processes of Thermal Decomposition.*—(a) From coal-gas. Proposals to make hydrogen from coal-gas are to be found quite early in the literature of hydrogen production. Thus, St. John (B. P. 1,466/1876) claimed the decomposition of the hydrocarbons in coal-gas by passage of the gas through a body of incandescent coke. The need for hydrogen was at that time small and the translation of the proposal into actual practice was not realised until much later. Many patents have subsequently been obtained on special methods of conducting the process. Lessing<sup>5</sup> proposed a definite temperature interval of 1,000-1,300° C. and retorts either empty or filled with carbon as a vehicle for the attainment of the necessary temperature. Since the thermal decomposition of hydrocarbons does not remove carbon monoxide, the patent of Nauss (B. P. 2,298/1910) proposed the removal of this constituent by passage of the coal-gas over reduced nickel at 200-300° C. whereby transformation to methane occurs at the expense of the hydrogen

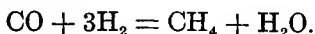

<sup>5</sup>B. P. 15,071/1909.

It may be pointed out that any carbon dioxide could be removed by the same treatment. The operation however would be beset, technically, with considerable difficulty unless means were first devised for removal of the carbon-sulphur compounds in the coal gas. These would poison the nickel catalyst and destroy its efficiency as a methanating agent. The gas after hydrogenation of the oxides of carbon was next to be subjected to a temperature of  $1,000^{\circ}$ - $1,200^{\circ}$  C., in which stage thermal decomposition of the hydrocarbons to yield carbon and hydrogen would be achieved.

The two processes which have come into technical application for hydrogen production from coal-gas, namely, the Oechelhauser and the Bamag-Bunte processes, do not involve such an elaborate procedure. As a result the product in each case represents only a crude form of hydrogen.

The Oechelhauser process consists in passing coal-gas through coke which has been preheated to  $1,200^{\circ}$  C. The coke acts partially as a filtering medium partially freeing the gas produced from the carbon formed. The residual carbon is removed by filtration of the gas through wood shavings. It is claimed that, in this manner, a total elimination of the heavier hydrocarbons could be secured and a reduction of the methane content from about 25 to less than 7 per cent. The carbon monoxide, normally present in coal-gas to the extent of 7 per cent is not appreciably altered in the process. As ordinary coal-gas contains nitrogen to the extent of several per cent this gas would also be a further impurity. The product therefore would be a hydrogen of doubtful applicability for the usual uses to which hydrogen is put. Its cost per unit volume should not be greater than that of the original coal-gas since the expense of the operation should be compensated for by the increase in gas volume accompanying the methane decomposition.

The Bamag-Bunte Process is similar in essentials and differs in detail. The coal-gas is freed from carbon dioxide before passage over white-hot coke. A purification from carbon monoxide by passage over heated soda-lime (see Chapter X) is also proposed. Nitrogen would then be the remaining residual, which, unless special precautions were taken with the original coal-gas production, would, however, be sufficiently great to detract considerably from the value of the hydrogen yield. The process does

not appear to possess any advantages over those previously discussed involving the interaction of water-gas and steam. The product should be markedly less pure with an operational procedure no simpler in actual practice.

(b) From natural gas, petroleum and tar oils.—Hydrogen from petroleum, natural gas and tars, is produced in a manner similar to that described in the last section and several technical applications of the method are in use for different purposes.

The Rincker and Wolter<sup>6</sup> process utilises heavy oils or tars for the production of hydrogen. Two generators filled with coke are used for the decomposition of the hydrocarbons. The coke is brought to a sufficiently high temperature by means of an air blast, the air producer gas from the first generator being mixed with a supply of secondary air and burnt in the second generator. By alternation of use as primary and secondary generators, both bodies of coke may be maintained at approximately equal temperatures. The temperature maintained is governed by the nature of the oil and the purity of the product desired, as would be anticipated from the theoretical considerations advanced in the introductory discussion to this chapter. For hydrogen production, the operating temperature is in the neighbourhood of 1,300° C. After the coke has been heated by this air blast, oil or tar is rapidly sprayed on to the coke from sprayers in the upper portion of the generators. To prevent thermal decomposition of the oil or tar in the sprayers, the oil is removed immediately after delivery of the charge, by blowing steam through the sprayers. In contact with the incandescent coke the oil is gradually vaporised and decomposed, the gas formed forcing its own passage to the purification system through water seals. The air-blow averages 1 minute, while the decomposition period is about 20 minutes in duration.

The carbon produced by the decomposition process remains in part on the coke and is consumed in the subsequent air-blow.

The gas purity attainable is said to be in the neighbourhood of 96 per cent hydrogen, the residue consisting of one-third nitrogen and two thirds carbon monoxide. Undecomposed hydrocarbons, especially methane, are doubtless also present. The impurities represent the gas present in the generators when the oil spray is started, and the products of materials other than hydro-

<sup>6</sup> F. P. 391,867 and 391,868/1908.

carbons in the oil. A purging with steam might bring about a diminution of the nitrogen content but not of the carbon monoxide. For the removal of this latter constituent the soda-lime treatment has also been proposed, a reduction of this gas to less than 0.5 per cent being claimed. To avoid clinkering troubles, Ellis has suggested <sup>7</sup> the addition of a small proportion of lime to the charge of coke, so as to act as a flux<sup>8</sup> for the ash produced.

As a portable hydrogen-producing plant, the Rincker and Wolter system has been used by both the German and the Russian Air Services. A unit capable of producing 3,500 cubic feet per hour can be mounted on two railway trucks. The essentials of the plant are two generators, a turbo-blower for the air-supply and an oil pump. The only raw materials requiring transport are coke and oil. The hydrogen produced has been found to be sufficiently pure for use, without additional purification, in kite balloons.

A patent to Ellis <sup>8</sup> describes an apparatus in which such an operation as the Rincker-Wolter process may also be carried out. A checker-brickwork chamber is substituted for the second coke generator. Frank <sup>9</sup> employs two generators containing coke or a refractory together with specially purified natural gas for the same purpose. Barth <sup>10</sup> and Lowe <sup>11</sup> have similar proposals for the production of carbon and hydrogen. Modifications of the Rincker-Wolter process studied in this country recently have demonstrated the possibility of obtaining a 96-98% hydrogen by this process. The residual gas is mainly methane and carbon monoxide which arises from the water or oxygen compounds present in the oil or introduced during the operating process.

A process devised by Brownlee and Uhlinger (U. S. P. 1,168,931/1916; 1,265,043/1918) has been utilised to produce a hydrogen, suitable for cutting and welding purposes, from natural gas as raw material. Petroleum oils may be substituted for natural gas but the plant is not then so simply operated. The process differs from the Rincker and Wolter process in that the necessary heat for thermal decomposition is obtained by combustion of a portion of the natural gas with air. A body of refractory ma-

<sup>7</sup> U. S. P. 1,092,903/1914.

<sup>8</sup> U. S. P. 1,092,903/1914.

<sup>9</sup> U. S. P. 1,107,926/1914.

<sup>10</sup> U. S. P. 1,729,925/1916.

<sup>11</sup> U. S. P. 1,174,511/1916.

terial is substituted for coke as the vehicle of heat storage. Special attention is paid to ensuring the absence of easily reducible oxides in the refractory. The operating temperature is above 1,200° C. Pressures greater than atmospheric are preferred. In the main, the carbon formed in the decomposition reaction is carried along with the hydrogen and may be removed from the gas by water washing. Any<sup>f</sup> carbon remaining in the refractory system is burned away in the subsequent air-blow. The carbon produced is suitable for certain purposes to which lamp-black is put, though it is of inferior quality to the product obtained by incomplete combustion of natural gas.

Operated for a cutting or welding product a gas containing 90-93 per cent hydrogen is produced, the residue consisting mainly of carbon monoxide and nitrogen with a little unchanged methane. For purposes in which a purer hydrogen is required, it is claimed that the initial product may be obtained with a hydrogen content greater than 95 per cent. This presupposes, however, a fairly pure natural gas. Natural gas with a high content of inerts would obviously be useless for pure hydrogen production. The economy of hydrogen production by this process compares favorably with that of other processes when a high purity is not essential. The addition of a purification system, however, would materially enhance the cost of the process. Special consideration will be given to such processes at a later stage.

The deterioration in the quality of carbon black produced by processes of thermal decomposition is ascribed by Bacon, Brooks and Clark to the length of time which the carbon remains in the heated zone of the system. The rich lustrous black which is first produced changes to a dull grey product when kept at a temperature of 1,200° C. To ensure a rapid removal of carbon from the heated zone with the consequent recovery of both carbon and hydrogen in a form of maximum commercial value, is the object of the patent proposals of Bacon, Brooks and Clark.<sup>12</sup> The liquid hydrocarbon is supplied in a thin stream to the decomposition zone of the plant which is made up of the annular walls of a series of graphite rings which are heated to a temperature exceeding 1,200° C. by means of an electric current, and are encased in a gas-tight refractory lining having an outside

<sup>12</sup> U. S. P. 1,220,391/1917.



metal shell. By adjustment of hydrocarbon supply and decomposition temperature a sufficient velocity of gas flow is maintained through the decomposition zone so that the carbon black is held in suspension and is rapidly carried away to a settling chamber, the hydrogen formed passing thence to a gas holder.

(c) *From Acetylene.*—The decomposition of acetylene has been operated by the Carbonium Gesellschaft of Friedrichshafen for the production of carbon black with hydrogen as a by-product. Early obstacles to the successful use of the process consisted in the low grade of carbon produced and difficulties in technical operation. These latter were overcome by operating according to the patents of Machtolf,<sup>13</sup> the acetylene being subjected to pressure not exceeding 6 atmospheres. The specifications provide one chamber for explosion of the gas and a carbon-black separator into which the gas-carbon mixture is blown and separated. A rotary scraper operating within the explosion chamber removes lamp-black adhering to the walls of the vessel and prevents its accumulation in the explosion system. When the technical difficulties were overcome the process was operated for a period of two years, the by-product hydrogen being used by the neighbouring Zeppelin station. It was found, however, that the carbon black produced was inferior to the better grades of American carbon black and consequently could not command an equal price in the market. This rendered the process uneconomical and according to information available in 1914 the process had been discontinued. It is not known whether, in recent years, the plant has again come into use.

The thermal decomposition of acetylene has been proposed by Pictet.<sup>14</sup> Since the formation of acetylene from its elements is an endothermic reaction, the decomposition is accompanied by the evolution of heat. Consequently a tube heated initially to 500° C. would rapidly rise in temperature when acetylene was decomposed within the tube, unless special devices were installed to keep the temperature constant. Pictet suggested a variety of ways in which this could be accomplished. The heat of reaction is more than sufficient to keep the process thermally self-sustaining. Hence, after the reaction has started, external heat is unnecessary, the incoming gases being automatically raised to

<sup>13</sup> D. R. P. 194,301/1905; 194,939/1905; 207,520/1907. B. P. 14,601/1906.

<sup>14</sup> B. P. 24,256/1910; F. P. 421,838/1910.

reaction temperature. The outlet end of the reaction tube can be cooled to prevent deterioration of the carbon-black resulting from the decomposition. The surplus heat may also be used up in the evaporation and thermal decomposition of liquid hydrocarbons having a positive heat of formation. Various other proposals involving the use of steam and the production of a hydrogen-carbon dioxide mixture are also included in the patent specifications. It seems unlikely that any of these proposals can have reached a technical stage of development partly owing to the raw materials cost and partly owing to the difficulties which the technical control of such mixed reactions would involve.

*Processes of Interaction with Steam.*—To promote the decomposition of hydrocarbons at lower temperatures than is possible with exothermic hydrocarbons by processes of purely thermal decomposition, interaction with steam in presence of a catalyst has been the object of many patent claims. As long ago as 1880 Stern<sup>15</sup> suggested the use of lime as contact agent for the decomposition of naphtha by steam. Dieffenbach and Moldenhaur<sup>16</sup> claim as active catalytic agents wire gauze made of nickel, cobalt, platinum or similar metals. By disposing the gauze at right angles to the direction of gas flow, a very short time of contact and thereby a sudden cooling of the reaction products could be secured. Operating in this manner, it was suggested that the carbon dioxide formed has little opportunity to be reduced to carbon monoxide. Oxygen could be added if desired to maintain reaction temperatures. It is extremely doubtful whether this process could be operated to yield a hydrogen-carbon dioxide mixture. Subsequent reaction at a lower temperature to cause the interaction of steam with any carbon monoxide produced to yield carbon dioxide and hydrogen would, therefore, seem to be necessary. The patent to the Badische Co.<sup>17</sup> specifies the use, as catalyst for the same reaction, of a refractory oxide such as magnesia, acting as catalyst support to nickel present in the refractory in concentrations ranging from 2 to 5 per cent and maintained at a temperature of 800°-1,000° C. Any carbon monoxide formed was to be removed in a subsequent operation. Ex-

<sup>15</sup> B. P. 2,787/1880.

<sup>16</sup> D. R. P. 229,406/1909.

<sup>17</sup> B. P. 12,978/1913.

periments with this process using such a catalyst and hydrogen containing small concentrations of methane gave poor results. This suggests that, even at the high temperatures specified, the hydrogen-carbon monoxide mixture produced by interaction of steam and hydrocarbons would contain residual undecomposed hydrocarbons unless impracticably low velocities of reaction were employed.

Pictet<sup>18</sup> suggests the use of high temperatures alone for the production of hydrogen and carbon monoxide from petroleum and steam.

In the preparation of a nitrogen-hydrogen mixture suitable for ammonia synthesis it has been stated that the use of an air-steam-producer gas-water-gas mixture results in a hydrogen-carbon dioxide-steam mixture containing only the equilibrium concentration of methane (see page 75) when an iron oxide catalyst at 500°-600° C. is used. The writer has not, thus far, been able to confirm this result experimentally. The point however is one of considerable technical importance since it suggests the possible utilisation of cheap gaseous by-products such as coke-oven gas for the production of hydrogen-nitrogen mixtures for ammonia synthesis.

<sup>18</sup> B. P. 14,708/1911.

## Chapter IX.

### Miscellaneous and By-Product Hydrogen Processes.

*The Decomposition of Alkali Formates.*—Alkali formates when subjected to moderate heat yield the corresponding oxalate with evolution of hydrogen

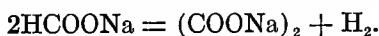

Since the development of synthetic methods for the production of formates this reaction has become increasingly important and capable of yielding marked amounts of hydrogen gas as a by-product. Thus, in the production of a 2,000 lb.-ton of oxalic acid, the by-product hydrogen should amount to not less than 8,000 cubic feet.

The reaction is ordinarily conducted with the sodium salt. Sodium formate can be prepared in a variety of ways, from caustic soda as starting point, utilising one or other of the technical fuel gases as source of carbon monoxide.

*Formate Synthesis.*—Goldschmidt's patent (B. P. 17,066/1895) claims the production of formate by the action of compressed carbon monoxide on caustic soda or, preferably, soda-lime, at a temperature of 230° C. The Elektrochemische Werke, Bitterfeld,<sup>1</sup> use a much lower reaction temperature of 100°-120° C. employing the gas under pressure. The presence of small quantities of moisture, 0.1 to 0.15 per cent water, in the caustic soda, accelerates absorption according to the claims of Nitridfabrik G. m. b. H.<sup>2</sup> The use of caustic soda solutions as absorption medium is the claim of other manufacturers. Koepf and Co.<sup>3</sup> use a 35 per cent solution and a temperature of 220° C., requiring, therefore, the employment of pressure. A later patent<sup>4</sup> replaces the alkali solution by alkali salts in admixture with

<sup>1</sup> B. P. 772/1906.

<sup>2</sup> B. P. 9,008/1906.

<sup>3</sup> B. P. 7,875/1904.

<sup>4</sup> D. R. P. 212,641/1904.

alkaline-earth hydroxides or by alkaline-earth hydroxides alone. Weise and Rieche<sup>5</sup> specify a 20 per cent soda liquor heated with the gas containing carbon monoxide under pressure. The United Alkali Co.<sup>6</sup> claim that rapid and complete absorption is obtained with the solid absorbent if titanitic acid to the extent of 11 per cent is present in the reaction mass. Norris<sup>7</sup> claims the use of ferric oxide for the same purpose.

Meister Lucius and Brüning<sup>8</sup> employ a calcined alkali carbonate and desiccated calcium hydroxide as the absorption agent. Ellis and McElroy<sup>9</sup> employ calcium carbonate suspended in water as the absorption agent, using carbon monoxide or air producer gas under pressure to effect the conversion to formate. Dubosc, Luttringer and Denis<sup>10</sup> propose the use of ammonia or organic bases in presence of metallic catalysts at temperatures between 90° and 170° C. at atmospheric pressure. Katz and Ovitz (U. S. P. 1,212,359/1917) allow a 32 per cent solution of sodium hydroxide to pass downwards in a finely divided condition through a tower up which a stream of ammonia and carbon monoxide is passing. A pressure of 10-20 atmospheres and temperatures been 150° and 220° C. are specified. Lackmann's patent<sup>11</sup> is similar to the earliest patents and uses granular sodium hydrate passing counter current to a stream of preheated water-gas or other gas rich in carbon monoxide.

*Formate Decomposition.*—As already stated, the decomposition of sodium formate is ordinarily undertaken with a view to maximum oxalate yield. The precautions taken in this direction, however, also favour pure hydrogen production, since the impurities in the gas arise from oxalate decomposition. A summary of a study of the process recently made by Leslie and Carpenter<sup>12</sup> shows that the best conditions for the conversion of sodium formate to oxalate are the following: (1) the admixture of sodium hydroxide approximating one per cent of the formate;<sup>13</sup>

<sup>5</sup> U. S. P. 1,098,139/1914.

<sup>6</sup> B. P. 13,953/1907.

<sup>7</sup> B. P. 4,684/1910.

<sup>8</sup> B. P. 8,012/1908.

<sup>9</sup> U. S. P. 875,055/1907.

<sup>10</sup> U. S. P. 1,019,230/1912.

<sup>11</sup> U. S. P. 1,274,169/1918.

<sup>12</sup> *Chem. & Met. Eng.*, 1920, 22, 1,195.

<sup>13</sup> Cf. Koepp & Co., B. P. 9,327/1903.

(2) an absolute pressure approximating 14 inches of mercury;<sup>14</sup>  
(3) a temperature of 350° C. As it is a matter of difficulty to heat a large quantity of formate quickly to 350° C. the conversion processes should be a continuous one in which small quantities of formate only are subjected to the influence of the experimental conditions at any one time. Unless the reaction mass is brought quickly to the stated reaction temperature other decomposition products result in greater or less degree. With these conditions observed a 90 per cent conversion to oxalate can readily be secured.

The hydrogen produced will contain varying quantities of carbon monoxide dependent on the efficiency of the conversion process. The secondary decomposition of sodium oxalate yields sodium carbonate and carbon monoxide.

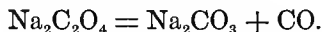

It is apparent that, both from the oxalate and the hydrogen standpoint, this is undesirable. The gas, if containing undue amounts of carbon monoxide, would require purification by one or other of the methods given in the succeeding chapter. No data as to purity of hydrogen attainable seem to be available, as, hitherto, the process has been conducted solely for oxalate production.

It should be pointed out that the decomposition of metallic formates does not always yield the corresponding oxalate. Dry distillation of calcium formate has long been known to yield formaldehyde, methyl alcohol, some acetone and also empyreumatic products in addition to gaseous products containing hydrogen, carbon monoxide and carbon dioxide. Solutions of the formates of zinc, lead, tin, copper, nickel and cobalt were shown by Ribau,<sup>15</sup> who heated the solutions in sealed tubes at 175° C., to yield hydrogen, carbon dioxide, metallic oxide or carbonate. Rubidium, calcium, barium and magnesium formates at 360°-420° C. give carbonate, no oxalate, and a gas containing the oxides of carbon.<sup>16</sup> Goldschmidt<sup>17</sup> showed that stannous formate gave

<sup>14</sup> Cf. *Elektrochemische Werke Bitterfeld*. B. P. 19,943/1907.

<sup>15</sup> *Compt. rend.*, 1881, 93, 1,023, 1,082.

<sup>16</sup> Merz and Welth, *Ber.* 1882, 15, 1,507.

<sup>17</sup> D. R. P. 183,856/1906.

high yields of formaldehyde and methyl formate when heated.

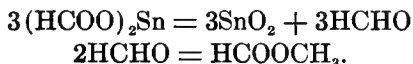

The hydrogen-yielding reaction is entirely secondary in this case. The problem of formate decomposition has recently been studied in detail by Hoffmann and his co-workers<sup>18</sup> who have shown that, with most formates, products other than hydrogen and the corresponding oxalate result. With sodium and potassium formates however, hydrogen is the first volatile product, oxalate being formed, secondary decomposition then leading to carbonate and carbon monoxide.

### *Hydrogen from Dehydrogenation Processes*

It is possible that the development which has occurred in the last two decades in regard to catalytic hydrogenation processes will be paralleled in the coming years by a similar development in dehydrogenation processes. In such case, hydrogen will be produced in quantity whereas now it is consumed. The logical development would seem therefore to be an extended effort to combine in one plant dehydrogenation processes with processes of hydrogenation so that the hydrogen produced in one operation could be utilised in the other. As an example of such from the history of the past few years the case of Messrs. Crosfield of Warrington, England, may be cited. Armstrong and Hilditch have recently recorded<sup>19</sup> that, during the war many hundreds of tons of alcohol were dehydrogenated to yield acetaldehyde. The hydrogen by-product was utilised for the hardening of liquid fats.

It is outside the scope of this volume to give a general treatment of the problem of dehydrogenation. Reference may be made in this matter to recent books on catalysis.<sup>20</sup> The general problem may be illustrated, however, by the special case already mentioned.

Sabatier and Senderens showed<sup>21</sup> that ethyl alcohol, when

<sup>18</sup> *Ber.*, 1916, 49, 303; 1918, 51, 1,398.

<sup>19</sup> *Proc. Roy. Soc.*, 1920, 97A, 259.

<sup>20</sup> For example: Rideal and Taylor. "Catalysis in Theory and Practice," pp. 207-229. Macmillan & Co., 1919.

<sup>21</sup> *Ann. Chim. Phys.*, 1905, [8], 4, 463.

passed over heated copper, preferably at about 300° C., is resolved into acetaldehyde and hydrogen

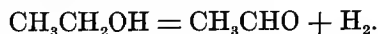

This process was developed by Messrs. Joseph Crosfield and Sons, Warrington, England, during the war, into a technical process whereby the aldehyde was produced, in large scale operation, with a conversion efficiency amounting to 90-93 per cent calculated on the alcohol used. From 20 to 25 per cent of the alcohol was converted at each passage over the metal into an equimolecular mixture of aldehyde and hydrogen. To obtain the former, the vapors were cooled and then passed into an elaborate fractionating column in which the aldehyde was separated from the hydrogen and alcohol.

The technical operations may be deduced from the following tables compiled from an experimental study of the process by Armstrong and Hilditch. These authors state that the proportion of by-products in their experiments was of the order obtained in the actual large scale process.

Alcohol Per Cent	Tem- pera- ture	Gas Evolved					Ratio $\text{CH}_3\text{CHO} : \text{H}_2$
		$\text{H}_2$	$\text{CO}_2$	$\text{C}_2\text{H}_4$	$\text{CO}$	" $\text{CH}_4$ "	
Anhydrous	300° C.	76.6	2.4	0.7	3.5	8.7	.67
92	300	91.0	1.5	0.3	0.0	4.0	.95
92	330-335	97.1	...	...	...	...	.55
92	325-330	98.9	...	...	...	...	.67
75	325-330	98.0	...	...	...	...	.83
50	325-330	91.7	...	...	...	...	.83

It is evident (a) that the presence of water improves the yield of acetaldehyde relative to that of hydrogen. (b) Using alcohol of a given concentration (e. g., 92 per cent), as the temperature is raised, the yield of aldehyde is considerably lessened, although the amount of alcohol decomposed and the volume of hydrogen produced are much increased. At 330° C. the proportion of alcohol attacked is about 50 per cent of the total quantity passed as against 20-25 per cent at 300° C. (c) At the higher temperature the yield may be partially restored by using



alcohol containing a larger proportion of water. (d) Even at 300° C., if alcohol rendered as anhydrous as possible be used, the yield falls seriously. (e) The use of 92 per cent alcohol instead of anhydrous alcohol raises the purity of the hydrogen obtained.

Whatever the conditions, small quantities of by-products were always produced, the total amount being normally of the order of 1 or 2 per cent of the aldehyde formed.

Assuming a 90 per cent theoretical hydrogen yield it may be calculated that per 2,000 lb.-ton of alcohol dehydrogenated a yield of upwards of 15,000 cubic feet of hydrogen can be produced. It is evident that, by suitable combination of such a process with an allied hydrogenation process, economies are possible. It is, doubtless, in the fine chemicals industry, that this and other by-product hydrogen processes will find their utility.

#### *Hydrogen from Fermentation Processes.*

The fermentation of starch by means of the "Fernbach" or "Weizmann" process, yields, as main reaction products, acetone and butyl alcohol. Fernbach showed in 1910 that by fermentation of starch-containing materials with a particular micro-organism the products were acetone and butyl alcohol in the ratio of 1 : 2. The shortage of acetone during the war led to a development of this process with the aid of a bacillus of the long rod type which was furnished to the British Government by Dr. C. Weizmann of Manchester. The manufacture of acetone by means of this culture was carried on in Britain, Canada and the United States, in the latter country at the plants of the Commercial Distillery Co., and of the Majestic Distilling Co., Terre Haute, Indiana.<sup>22</sup> The manufacture of acetone by the Weizmann process attained the greatest success at the factory of British Acetones, Toronto, Ltd., in Canada, where an output of 200 long tons a month was eventually reached.

As medium for the process a mash containing from 5-10 per cent of grain, usually maize, was employed. Fernbach's process, started at Kings Lynn, had previously employed potatoes which were at that time the cheapest raw material in England. An

<sup>22</sup> For further historical discussion of this subject see Conference on Recent Developments in the Fermentation Industries, *J. Soc. Chem. Ind.*, 1919, 38, 271 T.

important by-product in the fermentation process is the evolved gas, which, throughout a whole fermentation period, will analyse 50 per cent hydrogen and 50 per cent carbon dioxide. In quantity, an average of 5.5 cubic feet of mixed gas at 27° and 760 mm. can be obtained per pound of maize fermented. The ratio of hydrogen to carbon dioxide is not constant throughout the process as shown by the following table due to Reilly and others.<sup>23</sup>

<i>Time</i>	<i>Gas. C. ft/hr</i>	<i>CO<sub>2</sub></i>	<i>H<sub>2</sub></i>	<i>Air</i>
June 28/16				
4 pm.	...	....	....	100
7 pm.	253	11.5	38.5	50
8 pm.	834	27.1	57.9	15
9 pm.	822	40.3	55.2	4.5
10 pm.	660	40.0	59.0	3.0
11 pm.	760	50.3	47.2	2.5
June 29/16				
9.30 am.	1186	62	38	.....

From the time of the last observation to the end of the fermentation period the percentage of carbon dioxide did not alter. Reilly and his co-workers state that the high percentage of hydrogen in the early stages is probably due to solution of carbon dioxide in the mash. This view is disputed by Speakman<sup>24</sup> who showed by experiment that the gas produced at the immediate commencement is pure hydrogen the percentage of which begins to fall due to production of carbon dioxide with increasing rapidity. For the mechanism of the fermentation process he makes the following suggestions as to the sequence of changes:

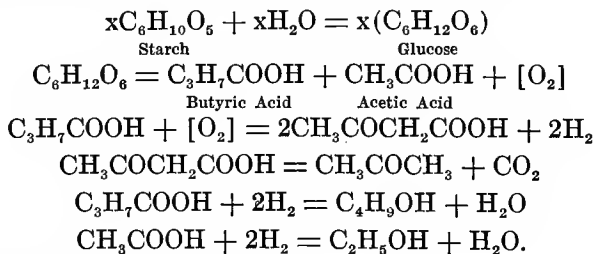

<sup>23</sup> *Biochemical J.*, 1920, 14, 229.

<sup>24</sup> *J. Biol. Chem.*, 1920, 43, 401.

The purification of such hydrogen for utilisation in various ways should not be difficult. The pressure water-washing process previously discussed (p. 72) would undoubtedly be the simplest method of converting the mixed gas into a sufficiently pure hydrogen for technical use.

The commercial feasibility of the acetone-butyl alcohol is conditioned by the use which may be made of both main products and of the by-products. The solid residue from the fermentation process, approximately 13 per cent of the total maize used, has a high oil and albuminoid content. Its dilution in the vat liquors is an obstacle to its successful utilisation, the concentration of solid matter being 1 cwt., in 1,500 gallons of liquor. The gases evolved have a distinct potential value which must be taken into consideration in a discussion of the possibilities of the process.

Fermentation processes yielding mainly acetone and ethyl alcohol with hydrogen as a by-product have also been the subject of experimentation.<sup>25</sup>

#### *The Hydrogenite Process.*

Analogous to the silicol and aluminium processes for the preparation of hydrogen this process uses ferro-silicon and alkali but at high temperatures with a relatively small amount of water. It is due to Jaubert<sup>26</sup> and was developed essentially for use in the field.

The exothermicity of the oxidation of silicon to the dioxide is the basis of the process



This reaction is sufficiently energetic that, once initiated, the action is sufficiently intense to bring about the withdrawal of oxygen from solid sodium hydroxide.

The material employed for field use consists of 25 parts of ferro-silicon, containing upwards of 90 per cent silicon, 60 parts of caustic soda and 20 parts of soda lime. It is produced in compressed blocks of an intimate mixture of these ingredients, originally in a finely powdered form. So produced, it is kept in

<sup>25</sup> Northrup, Ashe and Senior. *J. Biol. Chem.*, 1919, 39, 1; *J. Ind. Eng. Chem.*, 1919, 11, 723.

<sup>26</sup> *Rev. Gen. Chim.*, 13, 341, 357.

air tight containers until used. For use, the heavy lid is first loosened and allowed to rest on the container placed centrally in a water-jacketed generator. Reaction is started by applying a match to a small quantity of powder through a small hole in the lid. The reaction is propagated throughout the mass of solid and hydrogen is liberated at a high temperature with great rapidity. The heat of reaction is sufficient to generate steam in the water jacket of the generator and this steam is finally admitted to the reaction mass, increasing the hydrogen evolution and slaking the reaction mass. The net effect of the whole process is therefore, as in the silicol process,

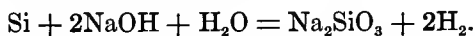

It will be seen, however, that the water required in this case is much less than that in the silicol process, in which a solution of caustic soda is employed.

The process is protected by numerous patents of which B. P. 153/1911 covers the reaction as just described. The French army has used the process in the field. Waggons holding 6 generators and a central cooler and washer have a capacity of 5,000 cubic feet of hydrogen per hour. The product is of a high purity similar to that obtained in the silicol process. The weight of materials necessary to the process is about 200 lbs. per 1,000 cubic feet of hydrogen and, therefore, about one and one half times the weight requiring transportation in the silicol process, providing water is available for the latter at the point of use. Where this does not hold, the hydrogenite process is manifestly advantageous. The cost of gas production is higher even than in the silicol process due to the greater proportion of alkali consumed.

An older process similar in principle to the "hydrogenite" process is based on the affinity of zinc for oxygen. Heated soda lime and zinc dust yield hydrogen

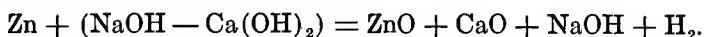

Experimental work on this reaction was conducted by Schwarz<sup>27</sup> and its applicability in the field has been tested by Majert and Richter.

<sup>27</sup> *Ber.* 1886, 19, 441.

*Hydrogen from Sulphides.*

Barium sulphide is oxidised by steam to barium sulphate, hydrogen being simultaneously formed.

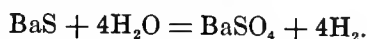

The barium sulphate may then be reduced by coal or producer gas to regenerate the sulphide.<sup>28</sup> The process does not seem to offer, as yet, technical interest sufficient to have earned for it close study.

Combination of this reaction with an oxygen-generating process is proposed by Teissier and Chaillaux (F. P. 447,688/1912) in the following sequence of reactions:

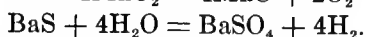
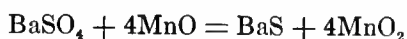

Iron pyrites treated with steam generates hydrogen, hydrogen sulphide and sulphur dioxide.<sup>29</sup> Temperatures between 750° and 1,000° C. are necessary. On cooling, the interaction of hydrogen sulphide and sulphur dioxide yields sulphur.

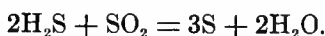

Residual sulphur dioxide may be removed by water washing, hydrogen sulphide by the usual purification methods (see p. 173).

*Hydrogen from Acids.*

Early aeronautical needs were supplied from acids and scrap metals. Normally such processes are too expensive in raw materials but are convenient occasionally, in the field, as special apparatus is not required. The British manual of military ballooning issued in 1896 described a plant for use in such cases. Dilute sulphuric acid (1 acid : 4 water) was employed, 30 gallons of such acid being used for 60 lbs. of granulated zinc. The gas was generated in a copper retort. The gas was freed from acid spray by passage through a layer of granulated zinc in a second copper chamber and passed thence through a water scrubber to a gas holder.

<sup>28</sup> Lahousse Fr. pat. 361,866/1905.

<sup>29</sup> Hooton B. P. 18,007/1914.

More recently, proposals to utilise acids for hydrogen production have involved waste acids or, alternatively, methods whereby the products of reaction could be utilised for other purposes. Thus, the utilisation of hydrochloric acid from the salt-cake process has been proposed, a tower packed with scrap iron to be used for absorption of the gas by water, the hydrogen produced by interaction of the acid and iron to be collected and the ferrous chloride worked up for other purposes. The interaction of zinc and dilute sulphuric acid, giving hydrogen and zinc sulphate has been suggested, provision being made to evaluate the process by working up the salt for the production of zinc carbonate as a pigment or a filler. The interaction of nitre-cake and scrap metals is a proposal for hydrogen production involving the consumption of cheap by-products.

## Chapter X.

### The Purification and Testing of Hydrogen.

The purification of commercial hydrogen is as important a section of hydrogen technology as the generation of the gas in quantity. This is so because, in the majority of uses to which the gas is put, the absence of certain impurities is essential. Thus, for example, in ammonia synthesis, traces of oxygen, carbon monoxide and water vapor exercise a very adverse effect on the synthetic operation when iron or iron-molybdenum catalysts are used. In the hydrogenation of oils, the reaction velocity of the hardening process is markedly decreased by the presence of "poisons" such as sulphides and carbon monoxide<sup>1</sup> and by diluents such as nitrogen, carbon dioxide and hydrocarbons.<sup>2</sup> In the reduction of tungsten and in the evacuation of electric filament lamps, absence of carbon compounds is desirable so as to minimize the presence of carbides in the metallic product. This also holds in the case of the fusion and working of the platinum metals.

Extended investigation will doubtless show that, by modification of the catalytic agent or of the operating conditions, catalytic hydrogenation may be carried out with hydrogen not so rigorously purified as is that now employed in the majority of cases. The use of water gas as reducing agent in the catalytic reduction of nitrobenzene in the vapor phase, the employment of "liquefaction process" hydrogen in certain fat hardening works are examples of efforts in that direction. In such cases, the economic balance will be struck between the expense of purification on the one hand and the lowered efficiency incidental to the use of the less pure product on the other hand.

The main impurities in industrial hydrogen prior to the carrying-out of special purification are hydrogen sulphide, car-

<sup>1</sup>Maxted. *Trans. Faraday Soc.*, Dec., 1917. Thomas. *J. Soc. Chem. Ind.*, 1920, 39, 10 T.

<sup>2</sup>Thomas, loc. cit. Armstrong and Hilditch, *J. Soc. Chem. Ind.*, 1920, 39, 120 T. *Proc. Roy. Soc.*, 1920, 93A 34.

bon sulphur compounds, carbon dioxide, carbon monoxide, hydrocarbons, nitrogen and water vapor. The number and amounts of these impurities present in any given technical product varies with the method of production and the efficiency with which the operation of production is conducted. Thus, hydrogen produced by the steam-iron processes has varied, in different plants visited by the writer, from 97 per cent to 99.9 per cent hydrogen. The former is an unnecessarily impure product, resulting from poor supervision and control of the plant. The latter represents a product produced under the strictest control and with sacrifice of yield to purity of product. In general, the product from the process is intermediate in quality but more closely approximating the higher quality example.

To obtain a general survey of the purification problem the following tabulated data are given referring to the impurities in the products obtained by the more important processes detailed in the preceding chapters. The purification processes which are outlined in the following pages have been worked out in the main with special reference to one or other of such products. The figures indicated in each case represent average practice rather than extreme cases. The figures are based on dry gases. Most of the products, however, would be saturated with water at ordinary temperatures.

Process	Hydrogen %	Hydrogen Sulphide and Carbon Disulphide	Carbon Dioxide	Carbon Monoxide	Hydrocarbons	Nitrogen	Oxygen
Steam-Iron ...	98.5-99	0.05	0.5-1	0.2-0.3	.....	0-0.25	.....
Liquefaction ..	97-97.5	....	....	1.7-2.0	.....	0.85-1.0	.....
Water-gas Catalytic (after CO <sub>2</sub> removal)	92.6	Traces	0.25	2.9	0.45	3.75	Possible Traces
Ditto with shift of equilibrium	96-97	Traces	Traces	0.0-0.2	0.3-0.5	3-4	.....
Electrolytic ...	99.5-100	....	....	.....	.....	.....	0-0.5

#### *Purification from Sulphur Compounds*

The main sulphur-containing impurity in technical hydrogen is hydrogen sulphide. Carbon sulphur compounds may be



present in minimal quantities. The processes in which these compounds require removal are the steam-iron process and the water-gas catalytic processes, together with the various processes starting from hydrocarbons, if these contain sulphur in the raw material. In the liquefaction process, all the sulphur compounds are removed either in the initial purification process prior to liquefaction (see Chapter IV) or are frozen out during the liquefaction of the carbon monoxide. In the electrolytic process the production of sulphur-containing impurities is highly improbable.

Owing to the ease with which the reaction

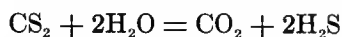

occurs in contact with iron or iron oxide at temperatures in the region of 300°-700° C., the gases produced in the steam-iron process and in the water-gas catalytic processes will only contain minute quantities of carbon disulphide. These will be too small, generally, to exercise any deleterious influence in the subsequent use of the gas. For, in the processes quoted, the reaction producing hydrogen involves a large excess of steam and the equilibrium in the above reaction is largely on the right hand side of the equation. Consequently, the removal of sulphur compounds will involve essentially the removal of sulphuretted hydrogen. This is generally the first of the impurities in hydrogen to be eliminated.

The gas may be removed from hydrogen by the same methods which are employed in gasworks practice for its removal from coal gas. The purification is attained by passage of the gases containing sulphuretted hydrogen through purifiers containing moist oxide of iron or, in certain cases, moist lime. For hydrogen sulphide alone the former is preferable, but when it is desired also to eliminate carbon dioxide, lime is frequently employed, though treatment with moist iron oxide followed by scrubbing with solutions of alkalis is coming into use. By whatever method practised, the purification can be carried to a high degree of completeness.

For iron oxide treatment, the principal materials finding application are bog iron ore, a naturally-occurring hydrated oxide of iron, and various artificially prepared hydrated ferric oxides. Thus, "Lux" a trade product finds much favour and is obtained

from bauxite by fusion with soda and subsequent lixivation, yielding a solution of sodium aluminate and a colloidal hydrated oxide of iron. Absorption of the hydrogen sulphide is generally carried out in a purification system consisting of closed boxes carrying trays of the material, either iron oxide or lime, generally lightened by sawdust or similar substances making for porosity. The arrangement of the purifiers and directions for efficient working are well known and can be learned from a standard gas works manual.<sup>3</sup> It must be mentioned that in hydrogen purification it is not possible to practice revivification *in situ* of the spent oxide as is usual in coal gas practice. This procedure consists in the simultaneous admission of the foul coal gas and air to the oxide box system whereby the iron sulphide obtained in the purification process

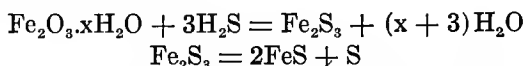

is simultaneously oxidised to sulphur and iron oxide

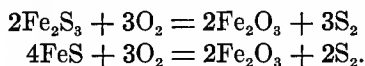

In this way a system of purifiers in coal gas practice can be maintained in use for a considerably longer interval of time than is possible if no air is admitted. For pure hydrogen production this is not possible owing to the nitrogen and other gases which would thus enter the hydrogen gas.

The low capacity which iron oxide boxes therefore have, when used for purifying hydrogen, as well as the expense involved in the charging and discharging of the purifier system, have prompted efforts which have been made to eliminate iron oxide box practice as far as is consistent with efficient removal of the impurity. Efforts have been made to remove sulphuretted hydrogen by scrubbing with a suspension of colloidal iron oxide in water. Experiment has shown that in this manner removal of the impurity is not complete<sup>4</sup> but that a large bulk of the hydrogen sulphide may be so removed. Economy of operation suggests, therefore, a dual system in which the main bulk of the im-

<sup>3</sup> See, for example, Meade, "Modern Gasworks Practice," pp. 384-414. D. Van Nostrand Co., 1916.

<sup>4</sup> Evans, *Gas Record*, 1919, 15, 215; *Gas Age*, 1919, 43, 475. *Chem. Abst.*, 1919, 13, 1,380.

purity is eliminated by the liquid scrubber, the final traces being removed by the usual box treatment. In this way a longer duty without discharge can be obtained from the boxes. Experimental work has recently established that the power cost on the liquid scrubber is but a fraction of that involved in labor on the renewal of oxide boxes.

For rigorous elimination of traces of sulphur compounds, scrubbing with iodine<sup>5</sup> and with copper sulphate solution<sup>6</sup> have been proposed. With efficiently operated iron oxide systems these should not be necessary, especially if the gases are subsequently to be freed from carbon dioxide by scrubbing with alkalis.

The removal of carbon disulphide from hydrogen is most conveniently attained technically by interaction with steam in presence of a catalyst, the hydrogen sulphide formed by the reaction,



being then removed in one or other of the ways already outlined. As catalytic agent, iron oxide or iron oxide-containing catalysts such as are detailed in the chapter on the water-gas catalytic process, are suitable. The patent of Guillet<sup>7</sup> calls for iron oxide as catalyst and a working temperature of 80°-200° C. In such case, however, the hydrogen sulphide is retained and, in course of use, the catalyst loses its activity owing to the formation of iron sulphide. Ridcal and Taylor<sup>8</sup> showed that, by operating at temperatures above 300° C., the hydrogen sulphide was not absorbed by the catalyst which could therefore be used continuously, the sulphuretted hydrogen formed being eliminated in a subsequent operation. The temperature at which hydrogen sulphide is no longer retained is conditioned in part by the concentration of steam in the reaction mixture. The same authors showed that this reaction could be conducted preferentially, the reaction of steam with carbon disulphide occurring more readily than that with carbon monoxide. Apparatus of the type described for the water-gas catalytic process is suitable also for this interaction of steam and carbon disulphide.

The Badische Co. (B. P. 14,509/1913), showed that carbon disulphide could be eliminated from hydrogen by passage of the

<sup>5</sup> U. S. P. 1,034,646/1912.

<sup>6</sup> D. R. P. 286,374/1914.

<sup>7</sup> B. P. 18,597/1912.

<sup>8</sup> B. P. 130,654/1919.

gas, at pressures above 5 atmospheres, through hot solutions of sodium hydroxide. As example, a 10-25 per cent solution at a temperature of 150°-225° C. under a pressure of 50 atmospheres was cited. The technical operation of this process is needlessly complex unless other objects are simultaneously to be achieved. The Badische Co. used this treatment originally for the removal of carbon monoxide and it was found that carbon disulphide was removed at the same time.

Carbon disulphide may be removed by processes of catalytic decomposition in presence of hydrogen

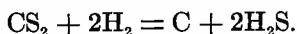

As catalytic agents platinum, nickel, bauxite, fireclay, pumice and iron oxide are suitable,<sup>9</sup> nickel having been used for the removal of carbon disulphide from coal gas on a large scale. Complete removal of the impurity is only attainable, however, at very elevated temperatures, so that the process would be less applicable to the case of hydrogen than the treatment with steam already discussed. In the case of coal gas, where the presence of carbon monoxide may, without special and careful control, give rise, with steam, to carbon dioxide production, the utility of this reaction with hydrogen is more apparent. The gradual deterioration of the catalyst by deposition of the resulting carbon in the contact mass constitutes an additional disadvantage of the process. In practice this must be burnt off at intervals and the contact mass freshly reduced. It is not surprising therefore that, as yet, this method of removal of carbon disulphide has not come into use in hydrogen purification.

The removal of carbon disulphide by cooling the gases to — 190° C. has been previously mentioned, the patent claims of Bedford and Williams<sup>10</sup> specially referring to this process. This method of removal also eliminates thiophene, a compound which is not removable, or only with difficulty, by the other methods outlined.

#### *Purification from Carbon Dioxide*

The method of removal of carbon dioxide from hydrogen varies with the quantity of the impurity present in the gas. For

<sup>9</sup> Carpenter, *J. Gas Lighting*, 1914, 126, 928. Evans, *J. Soc. Chem. Ind.*, 1915, 34, 9. Berk & Co., and Hood B. P. 143,641/1919.

<sup>10</sup> B. P. 3,752/1910.

gases with a percentage of carbon dioxide lower than 3 per cent, the most convenient, and probably the most economical, methods of removal utilise caustic alkali solutions or moist lime as absorption agent. With higher concentrations of carbon dioxide present, the expense of alkali absorption agents becomes excessive and use is made of water, alcohol or alkali carbonate solutions as solvent for the gas, compression of gas and solvent being used as an auxiliary in the process. Aqueous ammonia solutions have also been suggested as absorption agents, the ammonium carbonate solutions formed in the process being subsequently heated to 90° C., at which temperature the carbon dioxide may be expelled without marked loss of ammonia. Recent developments point to the combination of the water-gas catalytic process with the ammonia-soda process, in which case the carbon dioxide would be removed from the hydrogen by the ammonia entering the ammonia-soda cycle.

A purifier system, composed of rectangular boxes partially filled with hydrated lime arranged on shelves, is the usual apparatus in English practice for carbon dioxide removal from steam-iron process hydrogen containing 0.3 per cent of the impurity. The procedure was standard practice in the coal-gas industry in former times and specifications of plant required are to be found in manuals of gas works practice. Thus, Meade<sup>11</sup> suggests that the lime used should contain about 30 per cent of water in excess of that required to form the hydroxide. The depth of layer should be about 8 inches, to prevent the formation of channels in the material, thus avoiding the escape of untreated gas. With this depth of material and a set of four purifier boxes, an allowance of 0.7 square foot of area per box per 1,000 cubic feet of gas to be purified per day is sufficient in coal-gas technology. In view of the more rigorous requirements in the case of hydrogen, increase of this figure to 1.0 square foot would not be excessive. In this type of purifier, as in the case of iron oxide box purifiers, the labor and renewal charges are high. American practice has therefore replaced moist lime absorption systems with a scrubber system using sodium hydroxide solutions.

Scrubbers suitable for this purpose consist of cylindrical towers down which flows the caustic alkali solutions over coke or other filling material, the gas passing upwards and counter-

<sup>11</sup> *Loc. cit.*, p. 174.

current to the liquid flow. The rates of gas and liquid flow will obviously be governed by the carbon dioxide concentration. Ordinary water scrubber practice suggests the approximate capacity of tower space required.

Specifications for the removal of large concentrations of carbon dioxide by processes of pressure water washing have already been given (Chapter III). The use of alcohol in place of water, suggested by Bedford, would seem to be excluded technically on the score of cost. By either process, there appears to be residual amounts of carbon dioxide (0.1—1%) remaining in the gas, which are subsequently removed by scrubbing with aqueous alkalis. Claude<sup>12</sup> proposed to substitute lime water for water in the counter-current pressure washing system thus ensuring complete removal of the impurity. The complications thereby introduced owing to separation of calcium carbonate would seem to offset the advantages thus obtained.

The employment of solutions of alkali carbonates (of which potassium carbonate would be preferable owing to its greater solubility) is not a practicable proposal for purification of hydrogen from carbon dioxide if increased pressures are not employed. This is due to the slow rate of absorption of the gas at ordinary gas pressure when the concentration is decreased and also to the incompleteness of the removal. In the manufacture of carbon dioxide from exhaust and flue gases by absorption in alkali carbonate solutions and subsequent decomposition of the bicarbonate liquor, only about one-half of the carbon dioxide present in the original gas mixture is recovered, the rest passing to waste. The inapplicability of the process to hydrogen purification in such a form is therefore manifest. When pressure is employed the use of alkali carbonates instead of water seems less preferable owing to the cost involved in regeneration of the liquor.

#### *Purification from Carbon Monoxide*

The various types of industrial hydrogen containing carbon monoxide are broadly divisible into two classes, those in which concentrations of the impurity range from 0 to 0.5 per cent, and those in which the carbon monoxide concentration reaches 2 to 4 per cent. Steam-iron process hydrogen is typical of the former.

<sup>12</sup> B. P. 15,053/1914.

Hydrogen by the Griesheim-Elektron Co.'s process would also fall in this category if technically operated. The continuous water-gas catalytic process, the "liquefaction" process and processes of thermal decomposition of hydrocarbons yield hydrogen containing the upper range of carbon monoxide concentrations. Certain purification processes have particular application in respect to only one or other of the two types. Other processes are equally applicable to both.

*Conversion to Methane.*—The catalytic hydrogenation of carbon monoxide to yield methane is a method of purification which would, in general, be confined to gases containing the lower range of concentration. The reaction,

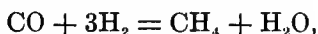

gives rise to methane which is itself difficult to remove. In the majority of uses to which hydrogen is put, methane is an inert constituent, but, in circulatory processes, such inert constituents accumulate and necessitate loss of hydrogen by purging. Furthermore, since three volumes of hydrogen are consumed in the removal of one volume of carbon monoxide a material hydrogen loss would occur in the treatment of gases containing 2-4 per cent carbon monoxide. Use of the methanation process is therefore generally limited to the elimination of traces of the impurity.

In this application the methanation process is extremely valuable. The reaction proceeds rapidly and quantitatively at 300° C., in presence of a nickel catalyst. The contact mass is cheap, a suitable material being readily prepared by soaking a silica brick material, such as Nonpareil brick, broken to suitable size, in a solution of nickel nitrate of such a strength that on withdrawing from the liquor and drying off, the content of the resulting material is 10 per cent with respect to metallic nickel. The nickelised brick so obtained is placed in position in the catalyst chamber and heated to 300° C. in an atmosphere of hydrogen. After the evolution of nitrogen oxides and ammonia has ceased, the material is in an active form for the methanation process. An active material will eliminate, quantitatively, carbon monoxide from 1,000 times its own apparent volume of hydrogen per hour at 300° C., if the carbon monoxide concentration does not exceed 0.5 per cent.

The gas to be treated by such a purification process must be rigorously freed from sulphur compounds in a prior operation. Otherwise, the activity of the catalytic agent shows a steady deterioration with use. Steam-iron process hydrogen which has received iron oxide box treatment and then treatment for removal of carbon dioxide is sufficiently pure for purification from carbon monoxide according to this process. The hydrogenation process may also be used at the same temperature for the removal of carbon dioxide, the reaction being

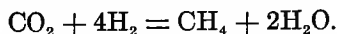

It is obvious, however, that this would be expensive as 4 volumes of hydrogen are consumed per volume of carbon dioxide. Since the latter is also present in steam-iron process hydrogen to the extent of 1 per cent or more, there would be a correspondingly large percentage of methane in the product. For this reason the carbon dioxide will normally be removed from the gas prior to the hydrogenation or methanation process.

*The Harger-Terry Process of Preferential Combustion.*—This recent process<sup>18</sup> for purifying hydrogen from carbon monoxide makes use of the discovery that, in presence of suitable contact agents, carbon monoxide is more readily oxidised than hydrogen. The process is peculiarly suited to hydrogen containing 0-0.5 per cent of the impurity. It has advantages over the preceding process in that the preferential combustion process may readily be conducted in presence of carbon dioxide, the product of reaction, moreover, being carbon dioxide, the whole of which may then be removed by the usual absorption processes. No accumulation of inert gas need, therefore, arise.

Metallic oxides and mixtures of the same form the most suitable catalysts for the preferential combustion process. With a definite catalyst there is a definite interval of temperature within which the oxygen present in a hydrogen-carbon monoxide-oxygen mixture is consumed mainly by the carbon monoxide. This interval is about 50° C. Thus, by taking hydrogen with a carbon monoxide content of 0.5 per cent, and adding 0.5 per cent oxygen (equal to twice the theoretical quantity required by carbon monoxide) the gas mixture may be freed from carbon monoxide by passage of the gas over a suitable preferential combustion cat-

<sup>18</sup> B. P. 127,609/1917.



alyst, maintained within the right interval of temperature. The excess oxygen not utilised by the carbon monoxide will be used by the hydrogen or may, in part, pass on unchanged.

The principal catalysts from the point of view of technical operation are copper oxide and iron oxide, alone or admixed with other oxides. Copper oxide and mixtures with other oxides, for example, manganese dioxide, are active in the neighbourhood of 100° C. Iron oxide or mixtures of iron, and chromium oxides or mixtures of iron, chromium and cerium oxides are active in the temperature interval of 200°-300° C. With such catalysts, suitably prepared, hydrogen may be freed from concentrations of carbon monoxide up to 0.5 per cent with the consumption of oxygen equal to a 100 per cent excess over that required by the carbon monoxide alone. The oxygen needed for the preferential combustion process is best supplied by means of electrolysis of aqueous alkalis, the hydrogen simultaneously produced being used to supplement the main supply of the gas after purification.

This process of preferential combustion has proved specially adaptable to the purification of steam-iron process hydrogen from carbon monoxide; trials on a large experimental scale have proved very successful and adaptation to technical operation is now being undertaken. The gas to be purified is first freed from hydrogen sulphide by iron-oxide box purification. It is then mixed with about 20 per cent by volume of steam and with oxygen in quantity calculated as sufficient for oxidation of twice the amount of carbon monoxide present. The steam acts protectively in restricting hydrogen combustion and also prohibits reduction of iron oxide catalysts. The mixed gases are passed through a catalyst chamber containing the oxides on trays, the temperature being carefully regulated to attain the maximum preferential effect.<sup>14</sup> The exit gases are next freed from steam in a scrubber and then passed to the carbon dioxide purification system. By this process it has been shown possible on the technical scale to remove more than 95 per cent of the carbon monoxide from steam-iron process hydrogen averaging 0.4 to 0.5 per cent carbon monoxide with a maximum hydrogen loss of 0.5 per cent.

Without modification, the preferential combustion process is not readily applicable to hydrogen gas containing the higher con-

<sup>14</sup> See Rideal, *J. Chem. Soc.*, 1919, 115, 995.

centrations of carbon monoxide, 2 to 4 per cent. Several reasons are involved. The most important reason relates to the thermal problem in question. The preferential nature of the oxide catalysts is generally restricted to a temperature interval of about 50° C. Copper oxide which will act as catalyst to oxidise carbon monoxide on hydrogen at 120° C., will normally act as catalyst for the combustion of hydrogen and oxygen at 170° C. Now the heats of oxidation of carbon monoxide and hydrogen

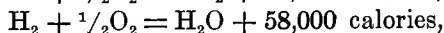
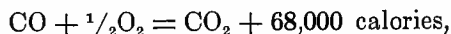

are sufficiently great to raise the temperature of a reaction mixture in which one per cent of either gas is oxidised by about 100° C. The preferential nature of the combustion is destroyed and hydrogen, by reason of its concentration alone, combines with the bulk of the oxygen. This difficulty could be overcome by arranging a cyclic operation in which the incoming gas of high carbon monoxide content could be diluted with the requisite amount of already purified gas to make an entering gas with a carbon monoxide concentration not exceeding 0.5 per cent. With such a procedure, however, it is apparent that by allowing an excess of oxygen equivalent to that required by the carbon monoxide, the loss of hydrogen, in a gas containing 3 per cent of the impurity, will also be 3 per cent. The expense of the process in hydrogen alone would become marked.

Rideal and Taylor<sup>15</sup> proposed to obviate these difficulties by operating a combined process of interaction with steam and preferential combustion on gases containing 2-4 per cent of carbon monoxide. The procedure recommended is to mix the gas, from which sulphur compounds have been removed, with one half its volume of steam and to pass the gas over a water-gas catalyst (see page 68) at a temperature of 400°-450° C. In this way by means of the reaction

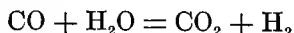

the concentration of carbon monoxide is reduced at the expense of the steam, approximately to the equilibrium concentration at the temperature stated. In this way, the carbon monoxide concentration in the issuing gas is diminished to less than 0.5 per

<sup>15</sup> B. P. 129,743/1918.

cent. On lowering the temperature, adding oxygen and passing once more over a catalyst containing iron oxide at 250° C. this residual impurity can be converted to carbon dioxide practically quantitatively. Experiments on a technical hydrogen made by the liquefaction process and on the product of the water-gas catalytic process after carbon dioxide removal, established the practicability of this procedure. The necessity for a two-stage operation which this involves naturally makes the process more expensive than the simple procedure applicable to steam-iron process hydrogen.

Investigations on the oxidation of carbon monoxide in air for gas-mask purposes conducted by the Chemical Warfare Service<sup>16</sup> showed the possibility of obtaining catalysts for carbon monoxide oxidation operative at ordinary temperatures. In hydrogen, these catalysts also function preferentially, but, owing to the poisoning effect of water-vapor on the low temperature catalysts, it is found that operation at ordinary temperatures is not readily possible. Temperatures in the neighbourhood of 100° C. are adequate to overcome this adverse effect of water vapor. Thus far, the process has not been operated successfully on any large scale with hydrogen containing, in addition to carbon monoxide, a large proportion of carbon dioxide, for example 30 per cent (see Chapter III, p. 74). The elimination of carbon monoxide in presence of such large quantities of carbon dioxide would represent a considerable step forward.

*Purification by Reaction with Soda-Lime or Lime.*—Carbon monoxide reacts with soda-lime at temperatures of 180° C. and upwards. The reaction proceeds in presence of hydrogen, so that it may be used for purposes of purification. At the lower temperatures in question, sodium formate is produced, but reaction velocity is slow. Consequently, pressure may be employed to facilitate reaction. At higher temperatures reaction also occurs, but, owing to decomposition of the formate, hydrogen and carbon dioxide are formed. Consequently, the soda is gradually converted to carbonate.

Lime, employed at 500° C., gives hydrogen and carbon dioxide from moist hydrogen containing traces of carbon monoxide. Steam favors the reaction and the efficiency of carbon monoxide

<sup>16</sup> Lamb, Bray and Frazer, *J. Ind. Eng. Chem.*, 1920, 12, 213.

removal is determined by the water-gas reaction. Iron oxide catalysts assist the process. The data already given in reference to the Griesheim Elektron process are applicable also to the case of purification with lime. Experiment shows that, at 500° C., in presence of lime and an iron activator, hydrogen containing 2 per cent carbon monoxide will be converted to a hydrogen carbon-dioxide mixture containing less than 0.1 per cent carbon monoxide in a single passage. The process suffers from the same disadvantages as the Griesheim Elektron process (q. v.) and requires a high temperature of operation.

*Purification by Aqueous Alkalis Under Pressure.*—The removal of carbon monoxide from hydrogen by interaction of the impurity with alkalis to form formates can be very effectively carried out by the use of solutions of the alkali at high temperatures, the prevailing pressure being sufficiently great to permit the necessary superheating of the solution. Thus, carbon monoxide in an original concentration of 2-4 per cent, such as occurs in the continuous water-gas catalytic process and in the liquefaction process, can be reduced to a concentration of less than 0.1 per cent by passage through a solution of sodium hydroxide at a temperature of 250° C., the gas pressure employed exceeding 50 atmospheres. The reaction occurring is expressible by means of the equation:

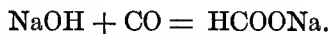

This process was originally employed by the Badische Co. for the purification of the hydrogen used for ammonia synthesis. The patents relating to the same<sup>17</sup> call for the use of 80 per cent sodium hydroxide solutions at 50 atmospheres pressure and 260° C., as well as the use of 25 per cent solutions at 200 atmospheres pressure and 240° C. The higher concentration is technically unsuitable owing to separation of the solid product of reaction.<sup>18</sup>

It is obvious that the technical difficulties associated with the conduct of such a purification process are very great. Experiments on a small scale show that the reaction is not rapid and is determined by the rate of solution of the carbon monoxide in the

<sup>17</sup> B. P. 1,759/1912; Fr. P. 439,262/1912; U. S. P. 1,126,371/1915 and 1,333,087/1915.

<sup>18</sup> See also, Weber, *Dissertation*, Karlsruhe, 1906; Fonda, *Dissertation*, Karlsruhe, 1908, for further data on the action of carbon monoxide on alkalis.

liquor. Consequently, acceleration of the reaction is brought about if the gas can be introduced into the absorbing liquor in as finely divided state as possible and at as high a pressure as possible. Alternatively, introduction of liquor in the "atomised" condition into the compressed gas space also makes for acceleration of reaction. The temperatures and pressures requisite, however, render such devices difficult of achievement. Indeed, the operation of lifting the liquor to the top of an absorption tower so that it may flow counter-current to a gas stream is attended with difficulties of an engineering nature which are by no means slight.

It is, therefore, not surprising that this method of purification has been displaced by others in which the technical difficulties are less pronounced. The sodium formate which results from the process is a valuable product up to the prevailing capacity of the market. The early operations of the Badische Co., however, created such a surplus of the formate that a market for the whole of it was found with difficulty.

Assuming no market for the formate, the process becomes expensive because caustic soda is consumed, and, since sodium formate on decomposition yields carbonate, causticisation is necessary before the salt can be turned back into the purification system. The high pressures necessary for the conduct of the process eliminate it from consideration in all cases except those in which hydrogen at high pressures is consumed. For high pressure hydrogen, the technique of the cuprous ammonium salt solution process next to be described is, relatively, so much simpler that it has superseded the process of absorption by aqueous alkalis.

*Purification by Absorption in Ammoniacal Cuprous Salt Solutions.*—This process, which was the method finally adopted by the Badische Co., for the purification of hydrogen from carbon monoxide for use in the synthetic ammonia process, is based on the well known reaction between carbon monoxide and ammoniacal cuprous salts solutions which forms the basis of carbon monoxide estimation in ordinary gas analysis. Carbon monoxide is slowly absorbed by such solutions with the formation of cop- per ion complexes containing carbon monoxide as illustrated by the equations:

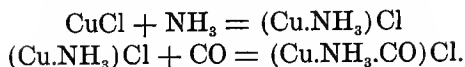

The proposal to remove carbon monoxide from technical gases by this method was first made by Huntingdon (B. P. 15,310/1884), the gas specified being producer gas and the action being intensified by the use of pressure both on gas and liquid. The copper solution after use was to be regenerated by subjecting it to a vacuum, whereby the carbon monoxide was evolved. Similar claims are embodied in Williams' patent<sup>19</sup> and in the patent to Linde.<sup>20</sup> On trial, the Badische Co. found that the utility of the process was marred by the solutions employed attacking the iron. Special patent claims were therefore made for particular solutions in which this adverse feature is eliminated. Thus, one patent<sup>21</sup> provides for the presence in the copper solution of at least 6 per cent of free ammonia or ammonium carbonate, for use in steel vessels under pressure. Later patents call for the elimination of halogens entirely<sup>22</sup> the halogen being replaced by weak acids such as formic and acetic acid. It is probably that ammoniacal cuprous formate was used as the absorption liquor on the technical scale in Germany in recent years. In the patent to the General Chemical Co. and De Jahn<sup>23</sup> the salt employed is the carbonate and is prepared by circulating a mixture of air and ammonium carbonate over pure copper until the requisite cupric ion concentration is attained, after which, the solution is circulated in absence of oxygen until the cupric ion is reduced to the cuprous condition.

Employed at 200 atmospheres pressure, an ammoniacal cuprous salt solution will absorb from hydrogen any oxygen that may be present, any residual carbon dioxide, by combination with the ammonia present, and finally, practically all of the carbon monoxide present in a gas containing 2-5 per cent of this impurity. The residual carbon monoxide concentration with efficient working of the process is less than 0.1 per cent. It is seldom below 0.01 per cent.

The quantity of solution required varies with the average concentration of the impurity, with the strength of copper solution

<sup>19</sup> B. P. 19,096/1889.

<sup>20</sup> D. R. P. 289,106/1914.

<sup>21</sup> B. P. 8,030/1914.

<sup>22</sup> B. P. 9,271/1914 and 20,616/1914; compare also U. S. P. 1,196,101/1916.

<sup>23</sup> B. P. 120,546/1918.

employed and with the prevailing gas pressure. Thus, a solution, one volume of which at 200 atmospheres pressure will absorb 20-30 volumes of carbon monoxide will absorb 4-5 volumes of the gas at a gas pressure of 10 atmospheres. It is thus apparent that the absorption is not a simple case of Henry's Law, but, on the contrary, a question of a decomposition equilibrium in the case of a carbonyl ion complex. Satisfactory removal of the carbon monoxide is obtained in technical practice if provision is made for a 15 minute period of contact between gas and absorbing liquid. This is generally attained in steel towers packed with a suitable packing material, the absorbing liquor being delivered at the prevailing pressure to the top of the towers and flowing downwards counter-current to the gas passing upwards. For the German plants, steel towers, 10 metres high, similar to those used for removal of carbon dioxide, were in use, at a working pressure of 200 atmospheres.

In a recent study, by Hainsworth and Titus,<sup>24</sup> of the problem of carbon monoxide absorption using cuprous ammonium carbonate solutions, it was shown that the absorption capacity of a solution having a given cuprous copper content was a function of several variables. It is dependent on the free ammonia content of the solution and on the partial pressure of carbon monoxide above it as well as on the concentration of cuprous copper. The absorption takes place due to the formation of an unstable compound in solution, probably containing one mole of carbon monoxide per gram atom of cuprous copper. This corresponds approximately to 0.2 pounds of copper per cubic foot of carbon monoxide. Cupric copper is reduced to cuprous copper fairly rapidly by carbon monoxide but the reduction of cuprous ion to copper is comparatively much slower. Oxygen present in small amounts, in gaseous mixtures from which carbon monoxide is to be removed by absorption will prevent the precipitation of copper and increase the capacity of the solution.

The spent ammoniacal cuprous liquor after leaving the absorption system is regenerated by release of the pressure on passage through a small receiving vessel and by raising the temperature of the liquor. The vessel may be worked at atmospheric pressure or with a partial vacuum. The latter is preferable from the point of view of carbon monoxide removal, but the ammonia losses

<sup>24</sup> *J. Am. Chem. Soc.*, 1921, 43, 1.

are thereby also increased. The evolved gas, consisting mainly of carbon monoxide, is freed from ammonia in a water scrubber and may be returned to the water-gas holder for conversion with steam to hydrogen and carbon dioxide in the water-gas catalytic process. In general, for removal of carbon monoxide from the ammonia liquor, temperatures as high as possible without decomposition of the solution are employed, presumably between 70° and 80° C.

For hydrogen, in the utilisation of which high pressures are necessary, this method of removing carbon monoxide is probably the most economical and practical yet introduced. On the other hand, for hydrogen required for use at normal pressure it is undoubtedly an expensive method, since, in such case, in addition to the actual operational expense, the cost of compression must be debited to the process.

*Purification by Interaction with Calcium Carbide.*—This process is widely quoted in hydrogen literature but is not practised. The process is recorded as a result of the Frank patents.<sup>25</sup> In these patents it is claimed that, at temperatures above 300° C., passage over the carbide, of hydrogen, containing carbon monoxide, carbon dioxide, nitrogen and hydrocarbons, results in the elimination of all these impurities. Experiment shows that, for practicable speed, the temperature of the carbide must be considerably higher than 300° C. Indeed, analysis of the claim in respect to only one of the impurities named will be sufficiently illuminating. It is common knowledge that, in the cyanamide industry, nitrogen is only absorbed readily by calcium carbide at temperatures in the neighbourhood of 800°-1,000° C. the nitrogen being present at atmospheric pressure. At such temperatures hydrogen purification is impracticable owing to expense of heating alone, even if the reactions quoted proceeded rapidly with gaseous impurities present in small concentrations. The possibility of contaminating the hydrogen with acetylene from the carbide is an additional argument against the use of this process.

#### *Purification from Methane.*

The elimination of methane impurities from hydrogen is not easily accomplished. The stability of methane and its dilution in a fairly pure hydrogen both render its removal from technical

<sup>25</sup> B. P. 26,806/1906; U. S. P. 964,415/1910.



gases difficult. Fortunately, in the majority of uses to which hydrogen is put, methane merely acts as a diluent. This diluent, however, increases steadily in concentration in a circulatory process, the increase finally necessitating a constant loss of hydrogen as a "blow-off," in order that the concentration of methane and other inert constituents may be kept within limits.

The removal of methane when present in concentrations of 1 per cent or less is attended with such expense that it is generally not attempted. The methods which might be employed, however, are economically more feasible with the "blow-off" gases, in which, owing to consumption of hydrogen, the methane concentration may have risen to 10-15 per cent.

For such gases there are two main possibilities in regard to purification, the one chemical, the other physical. The chemical method consists in bringing the methane-containing hydrogen with steam into contact with suitable catalysts, such as reduced nickel, at elevated temperatures (800° C.). Interaction occurs as previously outlined (Chapter VIII)

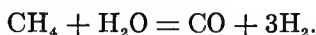

The issuing gas, if led over an iron oxide catalyst at a lower temperature (500° C.), gives, by interaction with excess of steam

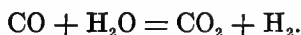

If the hydrogen is being produced by the water-gas catalytic process the latter reaction can be effected in the catalyst chamber normally operating on a water-gas steam mixture. In such case the subsequent purification would be as described in that process (Chapter III and earlier sections of this chapter). For other types of hydrogen production a special catalyst unit would be required for the carbon monoxide conversion as well as for the interaction of the methane and steam. The economics of the purification process would then require careful consideration.

For gases under pressure and containing a relatively high concentration of methane (e. g., 10 per cent) the physical method of methane removal is worthy of note. By cooling hydrogen containing methane in a liquid air cooling mixture to — 184° C., the partial pressure of the methane in the gas mixture may be reduced to 0.1 atm., the partial pressure of liquid methane at this temperature.<sup>26</sup> It would not be advisable to carry the cooling

<sup>26</sup> Olszewski, *Compt. rend.*, 1885, 100, 940.

below — 184° C. since at this temperature methane freezes. Its removal from the cooling coils would then be a matter of difficulty.

The degree of purification which could thereby be attained would depend on the pressure of the original gas mixture. The economics of the purification process would be similar to that of the "liquefaction" process of hydrogen production (Chapter IV). It would therefore only be applicable when large quantities of hydrogen containing marked concentrations of methane accumulated hourly or when provision for the cooling process was at hand for other purposes. With an efficient heat-exchange system, it should be observed, 80-90 per cent of the necessary cooling could be provided by the returning gases and by evaporation of the condensed methane.

#### *Removal of Phosphine and Arsine.*

These gases may be present in silicol process hydrogen and are detrimental to balloon fabric, in which such hydrogen is normally used, and to iron, copper and brass. They may be most readily removed by passing the hydrogen through a heated tube containing copper turnings. The two hydrides are decomposed, the phosphorus and arsenic combining with the copper. The quantities of impurity present are generally minute so that the copper can normally be replaced, when rendered inactive by interaction with the gases. Acid salts of copper, such as a hydrochloric acid solution of cuprous chloride will also decompose arsine and phosphine with the formation of copper arsenide and phosphide. It would be necessary to conduct this reaction in acid-proof vessels and the issuing gas would require scrubbing with water to remove acid vapors. Chromic acid could be substituted for the acid copper salt. The impurities present would be oxidised in this case to arsenic and phosphoric acids.

Bleaching powder in lump form has been suggested as an oxidising agent for the two gases.<sup>27</sup> The introduction of chlorine compounds into the gas by such treatment would be possible and special precautions to obviate this would be necessary.

The suggestion by Renard<sup>28</sup> that the gases might be removed by solution in petroleum cooled to —110° C., while practicable

<sup>27</sup> Wentzki, *Chem. Ind.*, 1906, 29, 405.

<sup>28</sup> *Compt. rend.*, 1903, 136, 1,317.

in the laboratory, does not seem to offer the possibility of technical application.

#### *Removal of Oxygen.*

Oxygen may be most readily removed from hydrogen by combustion of this latter gas with any traces of oxygen present, water being formed. A number of patents with reference to this have been filed. The combustion can be effected at low temperatures in presence of catalytic agents. Knowles<sup>29</sup> claims the use of platinised asbestos at 100° C. Reduced nickel is operative in the region 25°-300° C., the temperature varying with the activity of the nickel. It is therefore apparent that in the methanation process for the elimination of carbon monoxide, traces of oxygen will also be removed. Hot copper and glowing platinum wire have also been used for a similar purpose.

The operation is quantitative and so simple in any case that no difficulties in the use of hydrogen due to the presence of oxygen ever find record. It should be observed, however, that oxygen is as powerful a catalyst poison as carbon monoxide in many catalytic processes. Provision should therefore always be made to ensure its absence from gases required for such purposes.

#### *Removal of Water Vapor.*

Gas compression always reduces the percentage concentration of water vapor present in a gas. An installation of a drying system is therefore preferably inserted on the high pressure side of a system if economy of drying agent is to be sought. As desiccating agents, granular calcium chloride and soda-lime are the technical possibilities, though cooling may occasionally be adopted (Chapter IV). Physical adsorbents such as silica gel are finding application. With solid absorbents, a multiple unit system is generally adopted, one unit being continuously out of the series for revivification while the others are in use. In such a manner continuous desiccation may be achieved.

#### *The Testing of Hydrogen.*

(a) *Physical Methods.*—Hydrogen with a single impurity in variable concentration may readily be tested by means of an

<sup>29</sup> B. P. 27,264/1910; B. P. 21,600/1911.

"effusion" meter. This instrument measures the rate at which a definite volume of gas flows through an orifice of standard size. Since the velocity of effusion is inversely proportional to the square root of the density of a gas or gas mixture, hydrogen diffuses the most rapidly of all gases and an impure hydrogen less rapidly. Many types of apparatus based on this principle have been constructed. In the Schilling meter, of German origin, a fixed volume of gas is delivered from an inner glass cylinder standing in a solution of glycerine-water contained in an outer glass vessel. The delivery of the gas occurs through a standardised jet which is one of four exits in a four way tap fastened into the top of the inner cylinder. The other exits from the tap are utilised for filling the cylinder with hydrogen or air as required. Two marks on the inner cylinder indicate the volume of gas, the time of effusion of which through the jet is measured by means of a stop-watch. Standardisation of the apparatus can be made on air, tables being supplied recording the air time for various temperatures. Such standardisation also serves as a check on the cleanliness of the jet, concerning which great care must be exercised. By calibration of the meter against samples of hydrogen with known concentrations of the single impurity, tables or curves may be constructed from which, by a single set of measurements on the gas of unknown purity, the hydrogen concentration may be deduced. Where two or more impurities of varying concentration are possible, the method is not generally applicable without determination of the impurities and their concentration. In such case an effusion-meter is practically useless. In one special case, namely in "liquefaction" hydrogen, the use of an effusion-meter is possible. In this gas the impurities are practically exclusively carbon monoxide and nitrogen. Since these gases have identical densities they may be treated for the purposes of this measurement as a single impurity, thus enabling the purity of such hydrogen to be determined by such methods. If air be the diluent impurity the effusion meter is also applicable.

The Simmance Purity Meter constructed by Wright's Gas Meter Co. of London is a more rugged apparatus in iron, working on the effusion principle.

Recording apparatus, for hydrogen with a single impurity of variable concentration, can be constructed by utilisation of the

principle of buoyancy. If hydrogen of variable purity be delivered at constant gas pressure to an aluminium gas holder floating in a suitable liquid the height of the container in the liquid is determined by the density of the gas supplied. By attaching the gas holder to one arm of a sensitive balance and providing the other with a pen operating on a chart fastened to a revolving drum the variations in buoyancy and, therefore, in gas purity can be recorded. The use of such an instrument is limited to hydrogen admixed with a single impurity or to a number of impurities which, owing to the constancy of their relative concentrations, are equivalent to a single impurity in respect to their influence on density. Air is an example of such, as is also the nitrogen-carbon monoxide impurity of "liquefaction" hydrogen previously mentioned.

A method of hydrogen testing of great accuracy which can be rapidly operated, and can also be used with recording apparatus, is based on the principle of thermal conductivity. The thermal conductivity of hydrogen is very considerably greater than that of most gases, as the following table shows:

Gas .....	$k, \times 10^4$ <sup>80</sup>
Air .....	0.568
Ammonia .....	0.458
Carbon monoxide .....	0.499
Carbon dioxide .....	0.307
Ethylene .....	0.395
Methane .....	0.647
Nitrogen .....	0.524
Nitrous oxide .....	0.350
Oxygen .....	0.563
Hydrogen .....	3.27
Helium .....	3.39

For an historical account of thermal conductivity methods of gas analysis, reference may be made to the article just cited. In reference to the question of hydrogen testing, Prof. Shakespear of Birmingham, England, developed a "katharometer" in 1915 which is now sold in England by the Cambridge Scientific Instrument Co. and designed to sample and determine the amount of

<sup>80</sup>  $k_t$  is the heat in gram-calories flowing in 1 sec. through a distance of 1 cm. per sq. cm. for 1° C. drop in temperature. This table is cited from the Smithsonian Physical Tables by Weaver, Palmer, Frantz, Ledig and Pickering, *J. Ind. Eng. Chem.*, 1920, 12, 359.

air in hydrogen, which has been used as balloon gas, of hydrogen in air, for example, in the sheds used by airships, and for like purposes.

Shakespear's apparatus for the detection of hydrogen in air consists of similar electrically conducting wires arranged in cavities in a metal block, one of the cavities being closed and the other communicating by small perforations with the atmosphere. Current from a battery is passed through both wires, which are inserted in different arms of a Wheatstone bridge, a balance being then secured by means of other resistances. Under these conditions the heated wires remain at similar temperatures by losing heat at the same rate. An alteration in the proportion of hydrogen in the air will cause a variation in the heat loss from the exposed wire of which the change of resistance, as determined by readjustment of the bridge, is a measure.<sup>31</sup> For hydrogen containing air, provision may be made so that the gas mixture to be analysed flows over one wire, a comparison gas having a constant composition, such as pure hydrogen, and having a thermal conductivity of the same order as that of the gas mixture, passing over the other coil, or surrounding it.

The method has been extensively tested by Weaver and his collaborators<sup>32</sup> and has been utilised by them for the determination of nitrogen in nitrogen-hydrogen mixtures, and of carbon monoxide in a mixture of nitrogen, hydrogen and carbon monoxide. In the later paper, the limitations and advantages of the thermal conductivity method of gas analysis are discussed in detail. Reference may be made to these papers for detail of the procedure, which is likely to find extended application in hydrogen technology in the future.

The gas interferometer worked out by Haber and Löwe<sup>33</sup> is similarly applicable to variations of a single constituent or of a single constant mixture of constituents in hydrogen. The apparatus can be made very sensitive but it does not lend itself readily to technical usage owing to its cumbersomeness, nor can it readily be made an instrument of the recording type. Seibert and Harpster<sup>34</sup> have indicated some of the technical possibilities in the use of such an instrument.

<sup>31</sup> B. P. 124, 453/1916. U. S. P. 1,304,208/1919.

<sup>32</sup> Loc. cit. and *J. Ind. Eng. Chem.*, 1920, 12, 894.

<sup>33</sup> *Z. angew. Chem.*, 1910, 23, 1,393.

<sup>34</sup> U. S. Bur. of Mines Tech. Paper No. 185/1918.

Attempts have been made at the suggestion of officers of the Royal Air Force in England to determine the purity of hydrogen by acoustical methods.<sup>35</sup> The velocity of sound in air is 1,100 feet per second. In hydrogen it is as high as 4,100 feet per second. The variation in the two gases is such as should lead to the design of a rapid gas tester. As yet such is not forthcoming.

(b) *Chemical Methods*.—Absorption methods of hydrogen estimation are delicate and unsatisfactory for technical work. Paal and Hartmann<sup>36</sup> suggest the use of sodium picrate solution containing colloidal platinum as an absorbent for hydrogen. The process occurring is one of catalytic reduction of the picrate in presence of the colloidal metal. In principle it is identical with the proposal of Hofmann and Schneider<sup>37</sup> who employ as absorption agent, chlorate solutions containing colloidal osmium. For such absorption methods the hydrogen requires preliminary purification from impurities such as carbon dioxide, hydrogen sulphide, oxygen and carbon monoxide. Moreover, in technical hydrogen these gases are generally present in small amounts and it is the magnitude of these impurities that is generally more important than the hydrogen content.

Combustion methods with excess of oxygen or in presence of metals, such as palladium, or by metallic oxides such as copper oxide are applicable to hydrogen estimation. The presence of carbon monoxide must be determined by separate methods and corrected for, if high accuracy is required. Hydrogen and methane can be estimated in the same mixture by preferential combustion of the former with oxygen in contact with palladium or with copper oxide alone.<sup>38</sup> Methane, when present in hydrogen in small amount, is best estimated by complete combustion of a stream of the hydrogen with an excess of oxygen, the carbon dioxide formed being then determined by weighing. Allowance for any carbon monoxide present must in this case be made.

For the estimation of carbon monoxide in hydrogen use may be made of a modified iodine pentoxide method of determina-

<sup>35</sup> Compare :—Haber and Leiser. *J. Soc. Chem. Ind.*, 1914, 33, 54.

<sup>36</sup> *Ber.*, 1910, 33, 243.

<sup>37</sup> *Ber.*, 1915, 48, 1,585.

<sup>38</sup> See Hempel; "Gas Analysis," Richardt, *Zeitsch. anorg. Chem.*, 1904, 38, 65; Jaeger, *J. f. Gasbelucht.*, 1898, 41, 764.

tion.<sup>39</sup> At a temperature of 160° C. carbon monoxide is quantitatively converted to carbon dioxide according to the equation:

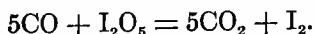

In air, by means of this reaction, concentrations of carbon monoxide as low as 0.001% may be readily determined by absorption and titration of the iodine formed. With hydrogen containing carbon monoxide, some reduction of iodine pentoxide by hydrogen results

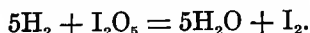

Consequently, carbon monoxide in such mixtures cannot be determined by means of the iodine titration. Instead, the iodine must first be removed by cooling and passage through mercury, and the carbon dioxide estimated by absorption in, and titration of, standard barium hydroxide solution. A word of caution is necessary relative to the absorption of carbon dioxide present in small quantities in hydrogen. In minute concentrations carbon dioxide will pass through a baryta solution unabsorbed unless extreme intimacy of contact is attained between gas and liquid. This can be obtained by the use of a centrifugal stirrer for the baryta solution through which the gas is bubbling. It is well, also, to employ an excess of alkali, estimating the excess by titration with acid. Methane is not attacked by iodine pentoxide but unsaturated hydrocarbons must be removed prior to the determination. This may be achieved by bubbling the gas through concentrated sulphuric acid at a temperature of 165° C.<sup>40</sup> The presence of gasoline vapors in the gas has been shown by Teague<sup>41</sup> to have a very deleterious effect on carbon monoxide determinations by the iodine pentoxide method. A method of procedure devised by Teague for exhaust gases from automobiles, and applicable also with minor modifications to carbon monoxide in hydrogen, calls for the use of a liquid-air cooled purification tube, which will remove from the gas most of the hydrocarbon vapors, including the unsaturated hydrocarbons, water and carbon dioxide. With such a purification good results were obtained on a complex mixture. The iodine pentoxide method applied to hydrogen gases

<sup>39</sup> Levy, *J. Soc. Chem. Ind.*, 1911, 30, 1,437. Graham, *ibid.*, 1919, 38, 10 T.

<sup>40</sup> Weiskoff, *J. Soc. Chem. Ind.*, 1909, 28, 1,170.

<sup>41</sup> *J. Ind. Eng. Chem.*, 1920, 12, 964.



containing carbon monoxide can be made to yield an accuracy of 0.01 per cent.

An application of the iodine pentoxide method to carbon monoxide detection and approximate estimation was developed by the Chemical Warfare Service <sup>41a</sup> based on the development of a green coloration in an  $\text{SO}_3 - \text{I}_2\text{O}_5$  mixture. This apparatus is being placed on the market by the Mine Safety Appliances Company of Pittsburgh, Pa.

A method of analysis for small quantities of carbon monoxide in hydrogen was worked out by Taylor on the basis of the Harger-Terry process of preferential combustion of carbon monoxide. To a measured volume of hydrogen was added oxygen or air sufficient to oxidise from 2 to 3 times the amount of carbon monoxide presumed to be present. The gas was then passed, in measured amount, over an iron-chromium cerium catalyst at  $230^\circ$  C., and the residual gas bubbled through standard barium hydroxide solution. The carbon dioxide formed by oxidation of the carbon monoxide was then estimated by back titration of the baryta with standard acid. Operating on gas mixtures containing 0.1 to 2 per cent, an accuracy of the same order as that attainable in the iodine pentoxide method was possible. The procedure was simpler as the process was catalytic and no complications, due to imperfect iodine absorption, were possible. Methane was not oxidised in the process even when present to the extent of 15 per cent. Precautions were necessary due to the absorption of carbon dioxide by the catalyst. To avoid such errors as this might cause, at least one litre of the gas mixture was passed through the catalyst chamber before the actual absorption in baryta was started. This method of carbon monoxide estimation was afterwards applied to the automatic carbon monoxide recorder devised by Rideal and Taylor,<sup>42</sup> in which the preferential combustion principle was combined with a method of carbon dioxide estimation based on the conductivity of lime water used as an absorption agent. This recorder, manufacture of which has been undertaken by the Cambridge and Paul Scientific Instrument Co. of Cambridge, England, has given good service in the estimation of carbon monoxide in steam-iron process hydrogen.

<sup>41a</sup> Cf. U. S. P. 1,321,061 and 1,321,062 to Lamb and Hoover.

<sup>42</sup> *Analyst*, 1919, 44, 89.

Catalytic agents other than iron oxide catalysts may be used. Prepared copper oxide or mixtures of copper oxide and manganese dioxide are applicable at 100° C. or even lower. Hofmann showed<sup>43</sup> that activated copper oxide moistened with alkali, or activated copper in presence of oxygen and moistened with alkali, also oxidise carbon monoxide, even at room temperatures.

The estimation of oxygen in electrolytic hydrogen is a case which is peculiarly suitable to the thermal conductivity method of estimation previously detailed. Of other methods of oxygen estimation applicable to recording devices, mention may be made of an arrangement employed by Rideal and Taylor. Use was made of a carbon dioxide recorder of the Simmance-Abady type,<sup>44</sup> although other forms of carbon dioxide recorders are equally useful. The charge of gas drawn into the apparatus in the usual way, was discharged, through a heated nickel catalyst, to the absorption system. This contained, instead of the usual potassium hydroxide solution, a quantity of water which served to condense any steam formed in the catalyst chamber by interaction of hydrogen and oxygen and also to cool the gases to atmospheric temperature. The residual hydrogen then passed to the measuring system as in the usual manner when the apparatus was used for carbon dioxide estimation. Since the reaction occurring in the catalyst chamber,

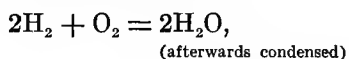

results in a diminution in volume equal to three times the volume of oxygen present, the readings recorded on the carbon dioxide chart when divided by three give the oxygen content of the hydrogen. Thus, a carbon dioxide chart recording up to 10 per cent of carbon dioxide for use, for example, on water-gas, can be used, with the stated modification, for recording concentrations of oxygen in hydrogen from 0 to 3.33 per cent. It is obvious that it may be similarly applied to the record of hydrogen in electrolytic oxygen. In such case the above chart would record from 0 to 6.66 per cent of hydrogen.

Greenwood and Zealley<sup>45</sup> also devised an apparatus for the automatic estimation of small amounts of oxygen in combustible

<sup>43</sup> *Ber.*, 1918, 51, 1,334.

<sup>44</sup> Precision Instrument Company, Manufacturers, Newark, N. J.

<sup>45</sup> *J. Soc. Chem. Ind.*, 1919, 38, 871.

gas mixtures or of combustible gases in air. They used heated platinum wire as the oxidation catalyst and provided their apparatus with a means for giving an alarm when the percentage of oxygen rose above a certain value. It cannot be claimed that their device is simple.

The detection of oxygen in hydrogen can be simply effected by the blue coloration imparted to colorless solutions of cuprous salts when gas containing oxygen is bubbled through the solution.

The detection and determination of phosphine in hydrogen, of importance in the case of hydrogen produced by the silicol process, has been thoroughly studied by Soyer.<sup>46</sup> For detection, the gas, after washing with water and removal of the water spray, is burned at a platinum jet and a porcelain cover is brought over the flame; a green coloration indicates phosphine. Spectroscopic examination of the flame shows clearly three phosphorus lines. Alternatively a drop of water suspended in the loop of a platinum wire and introduced into the flame for 1/15 second, will contain sufficient phosphoric acid to show a yellow precipitate with ammonium nitro-molybdate. This latter method is the basis of the process of estimation. The products of the combustion of from 2 to 20 litres of the gas are taken up with water and the phosphoric acid estimated as phospho-molybdate. With two litres of gas burned, a dilution of one part of phosphine in 5,000 parts of gas is determinable. With 20 litres, a concentration of one part in 60,000 parts is measurable. With 100 litres of gas, the sensitivity of the analytical procedure is extended to dilutions of one part of phosphine in one million of the gas.

Arsenic may be estimated by the usual method of passing the gas through a heated glass capillary, comparing the mirror obtained with standard mirrors. Sulphuretted hydrogen is detected by the blackening of a lead acetate paper placed in a T tube, at right angles to the path of the oncoming gas. Approximately quantitative results are obtained by comparison with standards, of the stains obtained in a given time with a given gas flow. Carbon disulphide may be similarly detected, after the passage of the gas over heated platinised pumice or reduced nickel at 500° C. The carbon disulphide is thereby caused to interact

<sup>46</sup> *Ann. chim. anal.*, 1918, 23, 221. *Chem. Abst.*, 1919, 13, 294.

with hydrogen, forming hydrogen sulphide, which can then be determined in the usual way.

The detection and estimation of acetylene in hydrogen has been standardised by Weaver.<sup>47</sup> The method is based on the formation of a red colloidal solution when the gas is absorbed in ammoniacal cuprous chloride solution containing 0.025% gelatine, 0.125% hydroxylamine hydrochloride and 50% alcohol. Comparison may be made with solutions containing a standardised red color. 0.03 milligram of acetylene can be detected by this method. Sulphuretted hydrogen and carbon dioxide interfere with the estimation and may be removed by hot alkaline pyrogallol. In the gravimetric determination of cuprous acetylide it was shown that the precipitate should be washed in the absence of air.

<sup>47</sup> *J. Am. Chem. Soc.*, 1916, 38, 352.

## Appendix I

A complete experimental re-investigation, by Chaudron, of the equilibria in the reactions

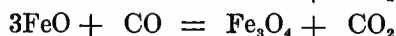
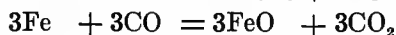
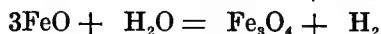
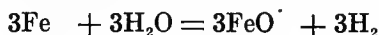

has been published since this book was set up and indexed. (*Annales de Chimie*, 1921, 16, 221.)

This research represents the most thorough and satisfactory work which has been performed in reference to these reversible reactions. As the data obtained in the research remove some of the difficulties in the way of acceptance of the earlier data they are here incorporated in the book. The appended diagram shows graphically the results obtained. The ordinates represent percentages of the reducing gas in equilibrium with iron-ferrous oxide and with ferrous oxide-ferrous ferric oxide at various temperatures plotted as abscissae.

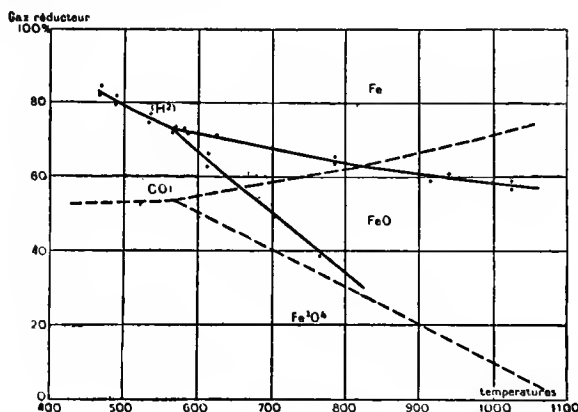

FIG. XVI.

It will at once be noted that the equilibrium values obtained vary noticeably from those given in Figs. I and II of the text.

Especially is this true of the equilibria involving carbon monoxide.

The results obtained give direct evidence as to their reliability. It will be noted that, for the curves involving both hydrogen and carbon monoxide as reducing gases, a triple point is obtained (570°) at which iron, ferrous oxide and ferrous ferric oxide coexist. The existence of this triple point was confirmed by experimental test. It was shown that ferrous oxide (which, if the diagram is correct, is unstable below 570°) slowly changes over to iron and ferrous ferric oxide when heated in a vacuum at 500° C.

The reliability of the experimental results is confirmed by the process of combining the results with both reducing gases. Thus, a combination of the equilibrium ratio,  $K_1 = p_{H_2O}/p_{H_2}$  with  $K_2 = p_{CO_2}/p_{CO}$  in presence of the same two solid phases at any one temperature should give the water-gas equilibrium,

$$\frac{p_{H_2O} \times p_{CO}}{p_{H_2} \times p_{CO_2}} = \frac{K_1}{K_2} = K$$

The values so obtained are in good agreement with the very reliable results obtained by direct measurement of the gaseous equilibrium. This is shown by the following table which gives, for iron and ferrous oxide as the solid phases, the individual and combined values of  $K_1$  and  $K_2$  and, in addition, the corresponding calculations for the water-gas equilibrium made by Haber.

Temperature	$K_1 = p_{H_2O}/p_{H_2}$	$K_2 = p_{CO_2}/p_{CO}$	$K = K_1/K_2$	$K$ (Haber)
686°	0.47	1.37	0.34	0.57
786	0.55	0.63	0.87	0.86
886	0.65	0.51	1.27	1.19
986	0.75	0.40	1.80	1.90

The new data do not make any substantial difference to the general conclusions, based upon the earlier experimental data, which were presented in the introductory section of Chapter II. The actual figures, however, presented on page 44, for the volumes of hydrogen and carbon monoxide consumed in the attainment of equilibrium conditions in the presence of the various solid phases will be altered by these new results. Accordingly,

in the following tables are presented more reliable data for the several equilibria.

$\text{Fe}_3\text{O}_4 - \text{FeO}$  REACTION.

<i>Temperature</i>	<i>% H<sub>2</sub> Consumed</i>	<i>% CO Consumed</i>	<i>Water-Gas : H<sub>2</sub></i>
570°	27	47	2.7
650	41	55	2.1
750	58	67.5	1.6
850	75	75	1.33

$\text{FeO} - \text{Fe}$  REACTION.

<i>Temperature</i>	<i>% H<sub>2</sub> Consumed</i>	<i>% CO Consumed</i>	<i>Water-Gas : H<sub>2</sub></i>
570°	27	47	2.70
650	30	44	2.70
750	35	40	2.66
850	38	36	2.70

It will be observed that the new results show the  $\text{Fe}_3\text{O}_4 - \text{FeO}$  cycle to be less favorable, as regards water-gas : hydrogen than was previously calculated. They demonstrate the advantage of working at higher temperatures on this cycle in so far as this water-gas : hydrogen ratio is concerned. The relative quantities of water-gas consumed to hydrogen yielded is much less dependent on temperature in the case of the  $\text{FeO} - \text{Fe}$  cycle, nor is this cycle so economical as regards water-gas. The percentages of hydrogen in equilibrium at the various temperatures in the two cycles during the steaming phase may readily be obtained from the figures in the second column of each of these last two tables.

## INDEX OF AUTHORS

- Abbott, 41.  
 Abrest, 130.  
 Adam, 100.  
 Alt, 91.  
 Altmayer, 148.  
 American Oxhydric Co., 109.  
 Ardol, Ltd., 92.  
 Armstrong, 163, 164, 171.  
 Ashe, 167.  
  
 Bacon, 156.  
 Badische Anilin u. Soda Fabrik, 28,  
     31, 52, 62, 65, 66, 69, 76, 77, 79,  
     92, 97, 99, 158, 175, 176, 184, 185,  
     186.  
 Baggs, 27.  
 Balfour, 29, 59.  
 Ballingall, 35.  
 Baly, 91.  
 Barth, 155.  
 Bates, 29, 37.  
 Battelli, 123.  
 Beaupré, 129.  
 Bedford, 99, 176, 178.  
 Bergius, 100, 123-127.  
 Berk and Co., 176.  
 Berlin Anhaltische Maschinenbau  
     Aktiengesellschaft, 41, 153.  
 Blair, 52.  
 Bosch, 41.  
 Bray, 29, 59, 183.  
 Brindley, 127.  
 British Oxygen Co., 29, 59.  
 Brooks, 156.  
 Brownlee, 155, 156.  
 Buchanan, 66.  
 Bunte, 23, 153.  
 Burdett Co., 110, 117, 118.  
 Burgess, 23.  
 Burrell, 23.  
  
 Carbonium Gesellschaft, 157.  
 Carpenter, 23, 161, 176.  
 Caspari, 105.  
 Chaillaux, 168.  
 Chaudron, 25, 201-203.  
 Clark, 156.  
 Claude, 16, 94-96; 100, 178.  
 Coehn, 105, 115.  
  
 Compagnie du Gaz de Lyons, 65.  
 Compagnie Generale d'Electro-  
     chemie de Bozel, 138.  
 Consortium f. Elektrochemische In-  
     dustrie, 132.  
 Coward, 22, 23.  
 Crosfield, 163, 164.  
 Curme, 100.  
  
 D'Arsondal, 108.  
 Day, 18.  
 De Jahn, 186.  
 Dellwik-Fleischer Co., 29, 45.  
 Dempster, 37, 48, 58.  
 Denis, 161.  
 Dewar, 100.  
 Dieffenbach, 29, 30, 63, 68, 86, 158.  
 Dixon, 22.  
 Donnan, 91.  
 Dubosc, 161.  
 Du Motay, 81, 86.  
  
 Eldred, 65.  
 Electrolabs Co., 115, 116, 118.  
 Elektrochemische Werke, Bitterfeld,  
     160.  
 Ellenberger, 81.  
 Ellis, 65, 82, 155, 161.  
 Ellworthy, 64, 65, 99, 100.  
 Engels, 82, 83.  
 Erdmann, 99.  
 Evans, 42, 174, 176.  
  
 Fairlie, 148.  
 Falcke, 27.  
 Falk, 22.  
 Faraday, 102.  
 Ferguson, 52.  
 Fernbach, 165.  
 Fischer, 91.  
 Foersterling, 127.  
 Fonda, 184.  
 Frank, 155, 188.  
 Frazer, 183.  
  
 Garuti, 108, 109.  
 Gauger, 23.  
 Gautier, 99.  
 General Chemical Co., 186.



- Giffard, 27.  
Goldschmidt, 160, 162.  
Gordon, 139.  
Graham, 196.  
Greenwood, 83, 84, 198.  
Griesheim Elektron Co., 63, 81, 84,  
87, 130, 179, 184.  
Griggs, 38, 40.  
Grimmes, 25.  
Guillet, 175.  
Gwosdz, 60.
- Haber, 16, 194, 195  
Hahn, 60.  
Hainsworth, 187.  
Harger, 58, 80, 180.  
Harpster, 194.  
Hartmann, 196.  
Hembert, 64.  
Hempel, 195.  
Henke, 81.  
Henry, 64.  
Hilditch, 163, 164, 171.  
Hills, 28.  
Hoffmann, 163, 195, 198.  
Hood, 176.  
Hooton, 169.  
Horine, 120.  
Hulett, 89.  
Huntingdon, 186.
- Improved Equipment Co., 41.  
International Oxygen Co., 110, 112,  
113, 114.
- Jacob, 27.  
Jaeger, 195.  
Jaubert, 57, 128, 132, 144, 167.  
Johnston, 63.  
Jouve, 99.
- Katz, 161.  
Knowles, 191.  
Koepp, 160, 161.  
Koester, 27.  
Krupp, 86.
- Lackmann, 161.  
Lahousse, 169.  
Lamb, 183.  
Lane, 28, 31, 32.  
Langer, 64.  
Latchinoff, 108.  
Leiser, 195.  
Leslie, 161.  
Lessing, 152.  
Lever Bros., 58.  
Levi, 82.  
Levin, 27, 115, 116.  
Levy, 196.
- Lewes, 27, 28.  
Lewis, 104, 147, 149.  
Linde, 186.  
Linde-Frank-Caro, 92-94, 97.  
Loewe, 194.  
Loewig, 66.  
Lowe, 155.  
Lowry, 89.  
Lundén, 30, 31, 57.  
Luttringer, 161.
- McElroy, 161.  
Machtolf, 157.  
Majert, 168.  
Maréchal, 86.  
Maxted, 31, 46, 50, 51, 66, 171.  
Mayer, 148.  
Mazza, 100.  
Meade, 174, 177.  
Meister Lucius & Bruning, 161.  
Merz, 82, 162.  
Messerschmitt, 28, 30, 37, 38.  
Moldenhauer, 29, 30, 63, 86, 158.  
Mond, 64.  
Monteux, 28.  
Moses, 41.  
Mueller, 65.
- Näher, 65.  
Nauss, 152.  
Neville, 88.  
Nitridfabrik, G. m. b. h., 160.  
Norris, 161.  
Northrup, 167.
- Oechelhauser, 153.  
Oerlikon Co., 110.  
Olzewski, 189.  
Osaka, 105, 115.  
Ovitz, 161.
- Paal, 195.  
Payman, 23.  
Phillip, 127.  
Pictet, 157, 159.  
Piva, 82.  
Plenz, 23.  
Pompili, 108, 109.  
Pring, 148.  
Prins, 87.  
Pullman, 65, 99.
- Ramsay, 123.  
Randall, 147.  
Read, 64.  
Reilly, 166.  
Renard, 190.  
Ribau, 162.  
Richards, 107.  
Richardt, 195.

- Richter, 168.  
Rideal, 49, 106, 115, 175, 181, 182,  
197, 198.  
Rieche, 161.  
Rincker, 154.  
Robertson, 23.  
Rogers, 122.
- Sabatier, 16, 126.  
St. John, 152.  
Santos Dumont, 15.  
Sarason, 130.  
Schaefer, 41.  
Schenck, 27.  
Schilling, 192.  
Schmidt, 109.  
Schneider, 195.  
Schoop, 106, 110.  
Schreiner, 25.  
Schriver, 110.  
Schuckert, 110.  
Schwartz, 168.  
Seibert, 194.  
Senior, 167.  
Shakespear, 193, 194.  
Shepherd, 18.  
Siedler, 81.  
Siegel, 54.  
Snelling, 99.  
Société Francaise L'Oxylithe, 132.  
Soddy, 100.  
Soyer, 199.  
Speakman, 166.  
Spitzer, 41.  
Stern, 158.
- Taylor, 49, 175, 182, 197, 198.  
Teague, 196.  
Teed, 134, 138, 145.  
Teissier, 168.  
Terres, 23.  
Terry, 180.  
Thomas, 171.  
Thorsell, 30, 31, 57.  
Titus, 187.
- Uhlinger, 155, 156.  
United Alkali Co., 161.  
Uyeno, 130.
- Van Royen, 27.  
Vignon, 65.
- Weaver, 132-138, 142, 146, 193, 194,  
200.  
Weber, 184.  
Weise, 161.  
Weiskoff, 196.  
Weith, 82, 162.  
Weizmann, 165.  
Wentzki, 190.  
Wheeler, 23, 118.  
Williams, 176, 186.  
Wolter, 154.  
Wright, 192.  
Wroblewski, 73.
- Young, 123.
- Zealley, 198.  
Zeppelin, 15.

## INDEX OF SUBJECTS

- Acetylene, detection and estimation in hydrogen, 200.  
 —, hydrogen from, 157-158.  
 Acids, hydrogen from, 169, 170.  
 Alkali formates, decomposition of, 160-162.  
 —, synthesis of, 160-161.  
 Aluminium-amalgam hydrogen process, 129.  
 Aluminium-sodium hydroxide process, 145.  
 Ammonia synthesis, hydrogen requirements for, 16.  
 Ammoniacal copper solutions, purification of hydrogen by, 185-188.  
 Analysis of hydrogen, 191-200.  
 Aqueous alkalis, hydrogen from, 131-146.  
 Aqueous alkalis, purification processes with, 184-185.  
 Argon in nitrogen-hydrogen mixtures, 74.  
 Arsine, detection and estimation in hydrogen, 199.  
 Arsine, removal from hydrogen, 190.  
 Bamag-Bunte process, 153, 154.  
 Bergius process, 123-127.  
 Burdett hydrogen cells, 117-118.  
 By-product electrolytic hydrogen, 120-122.  
 Calcium carbide, purification with, 188.  
 Carbon deposition, steam-iron process, 45.  
 —, — — —, prevention of, 46.  
 Carbon dioxide removal, 72, 73, 80, 176-178.  
 Carbon disulphide, removal from hydrogen, 175-176.  
 Carbon monoxide, catalytic decomposition, 45.  
 —, estimation in hydrogen, 195-198.  
 —, liquefaction of, 90-99.  
 —, removal of, 64-80, 90-99, 178-188.  
 Catalytic hydrogenation, 16, 179, 180.  
 Catalysts for interaction of hydrocarbons with steam, 158.  
 Catalysts for water-gas reaction, 64-69.  
 Chemical analysis of hydrogen, 195-200.  
 Choice of hydrogen process, 21, 22.  
 Classification of production methods, 19-21.  
 Claude liquefaction process, 94-96.  
 Coal gas, hydrogen from, 152-154.  
 Contact mass, steam-iron process, 28-31.  
 —, reduction of, 42-48.  
 —, steaming of, 48-52.  
 Cuprous salts, ammoniacal, for hydrogen purification, 185-188.  
 Dehydrogenation processes, hydrogen from, 163-165.  
 Dieffenbach and Moldenhauer process, 86-89.  
 — — — —, mechanism of, 88-89.  
 — — — —, theory of, 63.  
 Diffusion processes of hydrogen preparation, 99-100.  
 Efficiency of liquefaction process, 98-99.  
 — — silicol process, 144.  
 — — steam-iron process, 56-59.  
 — — water-gas catalytic process, 75.  
 Effusion meters, 191-192.  
 Electrolabs-Levin Cell, 115-117, 118.  
 Electrolytic hydrogen, 102-123.  
 —, apparatus for, 107-118.  
 —, by-product, 120-122.  
 Electrolytic hydrogen cells, Burdett, 117.  
 — — —, Garuti, 108.  
 — — —, International Oxygen Co., 110.  
 — — —, Levin-Electrolabs Co., 115.  
 — — —, Schmidt, 109.  
 — — —, Schoop, 110.  
 — — —, Schuckert, 110.  
 Electrolytic hydrogen production, theory of, 102-106.  
 — — —, operating details, 119.

- Equilibria, iron oxides and carbon monoxide, 27.
- , iron oxides and hydrogen, 25-26.
- , water-gas reaction, 45, 46, 50, 60, 61.
- , with steam and hydrocarbons, 150-152.
- Estimation of impurities in hydrogen, 191-200.
- Fermentation processes, hydrogen from, 165.
- Ferro-silicon specifications, for hydrogen production, 143.
- Field processes of hydrogen production, 127-130.
- , aluminium amalgam, 129.
- , hydrolith, 128.
- , metallic sodium, 127.
- Flow sheets, liquefaction process, 91.
- , water-gas catalytic process, 74, 76.
- Gas consumption, liquefaction process, 91, 98.
- , steam-iron process, 44-47.
- , water-gas catalytic process, 75.
- Gas interferometer, use of, in hydrogen analysis, 194.
- Greenwood's modification of Griesheim-Elektron Co's process, 84.
- Griesheim-Elektron Co's process, 80-86.
- , —, —, mechanism of, 82.
- , —, —, patent literature, 81.
- Griesheim-Elektron Co's process, purity of gas from, 85.
- , —, —, theory of, 62-63.
- Harger-Terry purification process, 180-183.
- Hydrocarbons, hydrogen from, 147-159.
- , —, —, theory of, 147-152.
- Hydrocarbons, interaction with carbon dioxide, 151.
- , —, —, steam, 158, 159.
- Hydrocarbons, thermal decomposition of, 152-158.
- Hydrogen from acetylene, 157-158.
- , —, acids, 169-170.
- , —, alkali formates, 160-162.
- , —, aluminium amalgam, 129.
- , —, aluminium-sodium hydroxide, 145.
- , —, aqueous alkalis, 131-146.
- , —, coal gas, 152-154.
- , —, dehydrogenation processes, 163-165.
- Hydrogen from diffusion processes, 99-100.
- , —, electrolytic processes, 102-123.
- , —, fermentation processes, 165.
- , —, ferro-silicon, 131-145.
- , —, field processes, 127-130.
- , —, hydrocarbons, 147-159.
- , —, Hydrogenite process, 167.
- , —, Hydrolith process, 128.
- , —, Lane process, 31-37.
- , —, liquefaction processes, 90-99.
- , —, Messerschmitt system, 37, 38.
- , —, natural gas, 154-157.
- , —, petroleum, 154.
- , —, sulphides, 169.
- , —, silicol process, 131-145.
- , —, sodium, 127.
- , —, steam, 25-59.
- , —, tar oils, 154-157.
- , —, volcanoes, 18.
- , —, water-gas, 90-99.
- , —, water-gas and steam, 60-89.
- Hydrogenite process, 167, 168.
- Hydrogen purification, 171-191.
- Hydrogen sulphide, removal from hydrogen, 173-175.
- Hydrogen supply, sources of, 18, 19.
- Hydrolith process, 128.
- Ignition temperatures of gases, 23.
- Inflammability of hydrogen, 23.
- Interferometer, use of, 194.
- International Oxygen Co.'s electrolytic hydrogen cells, 110-114.
- Lane generator, 32-34.
- Levin electrolytic cell, 115-117.
- Linde-Frank-Caro process, 92-94.
- Liquefaction processes, 90-99.
- , —, Claude process, 94-96.
- , —, composition of gas, 96, 97.
- , —, efficiency of, 98, 99.
- , —, flow sheet, 91.
- , —, Linde-Frank-Caro, 92-94.
- , —, plant details, 97-99.
- Messerschmitt hydrogen plant, 37, 38.
- Methane from carbon monoxide, 179.
- , hydrogen from, 152-158.
- , removal from hydrogen, 75, 152-158, 188, 190.
- Meteoric hydrogen, 18.
- Multi-retort generators, steam-iron process, 31-37.
- Natural gas, hydrogen from, 154-157.
- Nitrogen-hydrogen mixtures in water-gas catalytic process, 73.

- Nitrogen in liquefaction process hydrogen, 91.  
 Nitrogen in spent water-gas, 47.  
 Nitrogen in steam-iron process hydrogen, 50, 172.  
 Nitrogen in water-gas, 47.  
 Nitrogen in water-gas catalytic hydrogen, 50, 172.  
 Nitrogen, removal from hydrogen, 188.  
  
 Oechelhauser process, 153.  
 Over-voltage, hydrogen, 104, 105.  
 — oxygen, 104-106.  
 Oxygen detection in, 199.  
 — estimation in, 198, 199.  
 — removal from hydrogen, 191.  
 — requirements for preferential combustion, 180.  
  
 Petroleum, hydrogen from, 154-157.  
 Phosphine, detection and estimation in hydrogen, 199.  
 —, removal from hydrogen, 190.  
 Physical methods of hydrogen preparation, 90-101, 102-123.  
 Preferential combustion of carbon monoxide, 180-183.  
 Pressure water washing, carbon dioxide removal by, 80.  
 Purification of hydrogen, 171-191.  
 — from arsine, 190.  
 — carbon dioxide, 80, 176-178.  
 — carbon disulphide, 175.  
 — carbon monoxide, 178-188.  
 — hydrogen sulphide, 173-175.  
 — methane, 188-190.  
 — nitrogen, 188.  
 — oxygen, 191.  
 — phosphine, 190.  
 — water vapor, 191.  
  
 Reducing gases, steam-iron process, 42-48.  
 Rincker and Wolter process, 154-155.  
  
 Safety precautions, 22, 23.  
 Silicol process, 131-145.  
 —, experimental data, 132-139.  
 —, ferro-silicon specifications, 143.  
 —, generator problems, 136, 137.  
 —, heat effect in, 135.  
 —, operating details, 141, 142.  
 —, plant details, 139-141.  
 —, sludge disposal, 144.  
 —, sodium hydroxide requirements, 138.  
  
 Single retort system, steam-iron process, 37-41.  
 Soda-Lime, purification of hydrogen by, 183, 184.  
 Sodium, hydrogen from — and water, 127, 128.  
 Specific heats of carbon dioxide, carbon monoxide, hydrogen and steam, 55.  
 Spent water-gas, steam-iron process, 46, 47.  
 Steam-iron process, 25-59.  
 —, aeration, 52.  
 —, Bamag plant, 41.  
 —, contact mass, 28-31.  
 —, efficiency of, 56-59.  
 —, Grigg's modification, 38-40.  
 —, historical, 27, 28.  
 —, Lane generator, 32-34.  
 —, multi-retort type, 31-37.  
 —, purification of gas, 51-52, 171-191.  
 —, purity of gas, 50, 51, 172.  
 —, reduction phase, 42-48.  
 —, scavenging period, 49.  
 —, single retort type, 37-41.  
 —, steaming phase, 48-52.  
 —, thermal balance, 53-59.  
 —, water-gas-hydrogen ratio, 44-47.  
 Sulphides, hydrogen from, 169.  
  
 Tar oils, hydrogen from, 154-157.  
 Testing of hydrogen, 191-200.  
 — chemical methods, 195-200.  
 — physical methods, 191-195.  
 Thermal conductivity of hydrogen and other gases, 193, 194.  
  
 Utilisation of hydrogen, 15, 16, 17.  
 —, future possibilities, 17.  
  
 Vapor pressure of carbon monoxide, 92.  
 — nitrogen, 92.  
 Volcanic hydrogen, 18.  
  
 Water-gas, analysis of, 61.  
 Water-gas catalytic process, 64-80.  
 —, carbon dioxide removal, 72.  
 —, catalysts for, 64-69.  
 —, catalytic unit, 76.  
 —, flow sheets, 74, 76.  
 —, gas compressors, 79.  
 —, heat interchangers, 77.  
 —, operation of, 69-74.  
 —, outline of, 64.  
 —, plant details, 76-80.

- Water-gas catalytic process, steam consumption, 70-72.  
-----, theory of, 60-62.  
-----, water compressor, 79.  
-----, water-gas, hydrogen ratio, 75.  
Water-gas consumption, liquefaction process, 98, 99.
- Water-gas consumption, steam-iron process, 43-45.  
-----, water gas catalytic process, 75.  
Water-gas equilibrium, 45, 46, 50, 60, 61.  
Water-gas reaction, heat of, 54.  
Water vapor, removal from hydrogen, 191.













