



Calhoun: The NPS Institutional Archive
DSpace Repository

Theses and Dissertations

1. Thesis and Dissertation Collection, all items

2018-03

Sharing S-Band communications to conduct small satellite TT&C

Forbes, Austin E.

Monterey, California: Naval Postgraduate School

<http://hdl.handle.net/10945/58295>

Downloaded from NPS Archive: Calhoun



Calhoun is a project of the Dudley Knox Library at NPS, furthering the precepts and goals of open government and government transparency. All information contained herein has been approved for release by the NPS Public Affairs Officer.

Dudley Knox Library / Naval Postgraduate School
411 Dyer Road / 1 University Circle
Monterey, California USA 93943

<http://www.nps.edu/library>



NAVAL POSTGRADUATE SCHOOL

MONTEREY, CALIFORNIA

THESIS

**SHARING S-BAND COMMUNICATIONS TO CONDUCT
SMALL SATELLITE TT&C**

by

Austin E. Forbes

March 2018

Thesis Advisor:
Co-Advisor:

James H. Newman
Giovanni Minelli

Approved for public release. Distribution is unlimited.

THIS PAGE INTENTIONALLY LEFT BLANK

REPORT DOCUMENTATION PAGE			Form Approved OMB No. 0704-0188	
Public reporting burden for this collection of information is estimated to average 1 hour per response, including the time for reviewing instruction, searching existing data sources, gathering and maintaining the data needed, and completing and reviewing the collection of information. Send comments regarding this burden estimate or any other aspect of this collection of information, including suggestions for reducing this burden, to Washington headquarters Services, Directorate for Information Operations and Reports, 1215 Jefferson Davis Highway, Suite 1204, Arlington, VA 22202-4302, and to the Office of Management and Budget, Paperwork Reduction Project (0704-0188) Washington, DC 20503.				
1. AGENCY USE ONLY (Leave blank)	2. REPORT DATE March 2018	3. REPORT TYPE AND DATES COVERED Master's thesis		
4. TITLE AND SUBTITLE SHARING S-BAND COMMUNICATIONS TO CONDUCT SMALL SATELLITE TT&C			5. FUNDING NUMBERS	
6. AUTHOR(S) Austin E. Forbes			8. PERFORMING ORGANIZATION REPORT NUMBER	
7. PERFORMING ORGANIZATION NAME(S) AND ADDRESS(ES) Naval Postgraduate School Monterey, CA 93943-5000			10. SPONSORING / MONITORING AGENCY REPORT NUMBER	
9. SPONSORING / MONITORING AGENCY NAME(S) AND ADDRESS(ES) N/A			11. SUPPLEMENTARY NOTES The views expressed in this thesis are those of the author and do not reflect the official policy or position of the Department of Defense or the U.S. Government. IRB number N/A.	
12a. DISTRIBUTION / AVAILABILITY STATEMENT Approved for public release. Distribution is unlimited.			12b. DISTRIBUTION CODE	
13. ABSTRACT (maximum 200 words) Electromagnetic (EM) spectrum management is an escalating concern in today's growing wireless market, and ensuring that the growing number of EM spectrum users have adequate access will become only harder and more expensive as the number of users of cellular phones and satellite operations continues to grow. Utilizing and effectively sharing available spectrum is an involved process with many users competing for access. With the ever-increasing demand for EM spectrum, the creation and utilization of policies and regulations that support and encourage the co-utilization of EM spectrum bands is of growing importance. The Mobile CubeSat Command and Control (MC3) ground station personnel at the Naval Postgraduate School (NPS) in Monterey, California, conducted a series of tests with local news station KION to determine the feasibility of simultaneously using an S-Band uplink frequency to conduct telemetry, tracking, and communications (TT&C) with NPS CubeSats while KION conducted its electronic news gathering (ENG) operations. The testing determined that conducting TT&C satellite operations above 7 degrees of antenna elevation does not impact ENG operations in Monterey. Our results may encourage spectrum co-utilization and ease the strain on the increasingly congested EM spectrum.				
14. SUBJECT TERMS EM Spectrum Sharing, MC3 Network, SmallSat, CubeSat, electronic news gathering			15. NUMBER OF PAGES 83	
			16. PRICE CODE	
17. SECURITY CLASSIFICATION OF REPORT Unclassified	18. SECURITY CLASSIFICATION OF THIS PAGE Unclassified	19. SECURITY CLASSIFICATION OF ABSTRACT Unclassified	20. LIMITATION OF ABSTRACT UU	

THIS PAGE INTENTIONALLY LEFT BLANK

Approved for public release. Distribution is unlimited.

**SHARING S-BAND COMMUNICATIONS TO CONDUCT SMALL SATELLITE
TT&C**

Austin E. Forbes
Lieutenant, United States Navy
B.A., The Citadel, The Military College of South Carolina, 2010

Submitted in partial fulfillment of the
requirements for the degree of

MASTER OF SCIENCE IN SPACE SYSTEMS OPERATIONS

from the

**NAVAL POSTGRADUATE SCHOOL
March 2018**

Approved by: James H. Newman
Thesis Advisor

Giovanni Minelli
Co-Advisor

James H. Newman
Chair, Space Systems Academic Group

THIS PAGE INTENTIONALLY LEFT BLANK

ABSTRACT

Electromagnetic (EM) spectrum management is an escalating concern in today's growing wireless market, and ensuring that the growing number of EM spectrum users have adequate access will become only harder and more expensive as the number of users of cellular phones and satellite operations continues to grow. Utilizing and effectively sharing available spectrum is an involved process with many users competing for access. With the ever-increasing demand for EM spectrum, the creation and utilization of policies and regulations that support and encourage the co-utilization of EM spectrum bands is of growing importance.

The Mobile CubeSat Command and Control (MC3) ground station personnel at the Naval Postgraduate School (NPS) in Monterey, California, conducted a series of tests with local news station KION to determine the feasibility of simultaneously using an S-Band uplink frequency to conduct telemetry, tracking, and communications (TT&C) with NPS CubeSats while KION conducted its electronic news gathering (ENG) operations. The testing determined that conducting TT&C satellite operations above 7 degrees of antenna elevation does not impact ENG operations in Monterey. Our results may encourage spectrum co-utilization and ease the strain on the increasingly congested EM spectrum.

THIS PAGE INTENTIONALLY LEFT BLANK

TABLE OF CONTENTS

I.	INTRODUCTION TO EM SPECTRUM MANAGEMENT	1
A.	ORIGINS OF SPECTRUM MANAGEMENT	2
1.	The Radio Act of 1910	3
2.	The Radio Act of 1912	4
3.	The Radio Act of 1927	6
B.	SPECTRUM MANAGEMENT TODAY	7
1.	EM Spectrum Auctions	12
2.	Channel-Sharing	15
II.	S-BAND RADIO FREQUENCY INTERFERENCE TEST	19
A.	INTRODUCTION	19
1.	Coordination	21
2.	Objectives.....	21
B.	MOBILE CUBESAT COMMAND AND CONTROL OVERVIEW	22
1.	MC3 Network Geography	22
2.	MC3 Equipment.....	23
3.	ENG Introduction	25
4.	ENG Equipment	27
C.	RFI TESTING	29
1.	Site Geometry	29
2.	Spectrum Measurement	31
3.	Constraints.....	33
4.	Testing Communications.....	34
5.	NPS 3-Meter Antenna Pattern Characterization	34
6.	RFI Measurement Responsibilities	35
7.	ENG Signal Quality Metrics.....	36
8.	ENG NuComm CR-7 Receiver.....	38
9.	Test Conditions.....	39
10.	An Unexpected RFI Testing Opportunity.....	41
11.	Measurement Procedures	42
D.	TESTING RESULTS	43
1.	SATOPS Antenna Characterization.....	43
2.	RFI Measurements.....	45
III.	CONCLUSIONS AND FUTURE OPERATIONS.....	57
A.	RFI TEST RESULTS ANALYSIS.....	57

B. FUTURE TESTING	59
LIST OF REFERENCES.....	61
INITIAL DISTRIBUTION LIST	65

LIST OF FIGURES

Figure 1.	Re-creation of the Titanic’s Radio Room. Source: [5].....	5
Figure 2.	Adults Using Internet and Smartphones. Adapted from [11].....	8
Figure 3.	Smartphone Users in the United States. Source [12].	9
Figure 4.	SmallSats Launched. Source [13].	10
Figure 5.	SmallSat Launch Attempts. Source [13].	11
Figure 6.	Cisco Forecasts for Mobile Data Traffic. Source [14]	12
Figure 7.	KLCS/KJLA Channel Sharing Pilot Results. Source [20].....	17
Figure 8.	FCC Table for USB License. Source [22]	20
Figure 9.	MC3 Ground Stations. Source: [24].....	23
Figure 10.	3-Meter S-Band Antenna.....	24
Figure 11.	Ground Terminal Configuration. Source [25].	25
Figure 12.	ENG USB Spectrum Channel Layout. Source [25].....	26
Figure 13.	Mt. Toro KION-TV Central Receive System Configuration. Source [25].	28
Figure 14.	Mt. Toro Central Receive Site. Source [25].	28
Figure 15.	Mobile and Fixed ENG Transmitters [25].....	29
Figure 16.	NPS to Mt. Toro Terrain. Source [25].	30
Figure 17.	ENG, SATOPS Transmitter Locations. Source [25].....	30
Figure 18.	EM Spectrum Analysis Equipment. Source [25].	32
Figure 19.	EM Spectrum Analysis Equipment Diagram. Source [25].....	32
Figure 20.	ENG Antenna Controller (NAVIGATOR II) and Receiver (NuComm Newcaster CR7). Source [25].....	36
Figure 21.	ENG Receiver Interface Screen. Source [25].	37
Figure 22.	Live Video Feed from Wharf. Source [25].	38

Figure 23.	RFI Testing Monitored Signals. Source [25].	41
Figure 24.	Signals Monitored during Cursory on-Tune RFI Measurements. Source [25].	42
Figure 25.	NPS 3-Meter Beam Pattern Characterization. Source [25].	44
Figure 26.	Post-Acquisition RFI Test Results, ENG Channel 5 (Wharf Tx). Source [25].	47
Figure 27.	Post-Acquisition RFI Test Results, ENG Channel 4 (Van Tx). Source [25].	48
Figure 28.	Pre-Acquisition RFI Test Results, ENG Channel 5 (Wharf Tx). Source [25].	48
Figure 29.	Pre-Acquisition RFI Test Results, ENG Channel 4 (Van Tx). Source [25].	49
Figure 30.	RCL Comparison. Source [25].	50
Figure 31.	Link Quality Comparison. Source [25].	51
Figure 32.	MER Comparison. Source [25].	51
Figure 33.	BER Comparison [25].	52
Figure 34.	Repeated Tests Link Quality. Source [25].	53
Figure 35.	Repeated Test MER. Source [25].	54
Figure 36.	Repeated Tests BER. Source [25].	54

LIST OF TABLES

Table 1.	FCC Auction Examples. Adapted from [16].....	13
Table 2.	Federal Assignments in 1755–1850 MHz before AWS-3. Source [17]......	14
Table 3.	Three-Meter Dish Basic Information. Source [25].....	24
Table 4.	ENG Test Locations. Source [25]......	31
Table 5.	NPS 3-Meter SATOPS Antenna Gains. Source [25].	44
Table 6.	RFI Test Results. Source [25].	45
Table 7.	Cursory On-Tune RFI Measurements. Source [25].	55

THIS PAGE INTENTIONALLY LEFT BLANK

LIST OF ACRONYMS AND ABBREVIATIONS

AFSCN	Air Force Satellite Control Network
AWS-3	Advanced Wireless Service 3rd Generation
BAS	Broadcast Auxiliary Service
BER	Bit Error Rate
BPSK	Binary Phase Shift Keying
BW	bandwidth
C/I	Carrier-to-Interference Ratio
COFDM	Coded Orthogonal Frequency Division Modulation
CONOPS	Concept of Operations
COTS	Commercial Off-the-Shelf
CW	Continuous wave
DD	Department of Defense
ENG	Electronic News Gathering
FCC	Federal Communications Commission
FEC	Forward Error Correction
GOTS	Government Off-the-Shelf
GUI	Graphical User Interface
IF	Intermediate Frequency
LEO	Low Earth Orbit
LNA	Low Noise Amplifier
LOB	Line-of-bearing
LOS	Line-of-sight
MER	Modulation Error Ratio
NPS	Naval Postgraduate School
NTIA	National Telecommunications and Information Administration
PPSG	Policy and Plans Steering Group
QPSK	Quadrature Phase Shift Keying
RCL	Received Carrier Level
RF	Radio Frequency
RFI	Radio Frequency Interference

Rx	Receive(r)
SATOPS	Satellite Operations
SBE	Society of Broadcast Engineers
SDR	Software defined Radio
SGLS	Space Ground Link Subsystem
SmallSat	Small Satellite
SSN	Space Surveillance Network
TRR	Tactical Radio Relay
TT&C	Telemetry Tracking and Communications
Tx	Transmit(ter)
UCS	Union of Concerned Scientists
USB	Unified S-Band

ACKNOWLEDGMENTS

I must first thank the Space Systems Academic Group at the Naval Postgraduate School for the incredible opportunity to advance my knowledge and experience in the space community. I had an unforgettable experience learning from an extremely studied and knowledgeable group of academics. Nothing can replace the knowledge I gained or the time I spent there. Thank you, Dr. Newman, for your invaluable guidance. Thank you, David Rigmaiden, for the knowledge and hands-on experience that you shared with me. Thank you, Gio Minelli, for your support and encouragement in getting my writing done.

I owe a huge debt of gratitude to the Alion Group for its in-depth knowledge and experience regarding the radio frequency interference testing we conducted. I could not have completed this work without their help.

Thank you to KION engineer Adam Perez. We could not have started without your willingness to assist us, essentially working to occupy your broadcast bandwidth. You provided access to your equipment and knowledge selflessly, all in the name of expanding our knowledge. All of this you did voluntarily, with never a question of reimbursement.

Thank you to my wife, Tiffany. She supports me in everything I do and allows me to apply myself in my work. She always makes sure our three children are taken care of and our household is managed.

THIS PAGE INTENTIONALLY LEFT BLANK

I. INTRODUCTION TO EM SPECTRUM MANAGEMENT

Technological advances and an exponentially growing population have filled the Earth's surface and surrounding space with invisible frequencies carrying wireless communications. These communications reside inside a small portion of what is known as the electromagnetic spectrum and allow the performance of an enormous amount of daily functions. The full breadth of wireless operations is expansive, and they complete the operations that many have taken for granted as automatic functions of everyday living. The applications are ubiquitous and range from the cell phone used to communicate, to the radio station played in the car, to the satellite television broadcast from a geostationary satellite to a living room. Wireless technology infiltrates life in innocuous ways, and many beneficiaries of this technology do not even understand what is required for these seamless operations.

There is a finite amount of bandwidth (BW) available for the wireless transmission and reception technologies that exist in today's world. This limited BW is managed by multiple entities that do not have the capability to create spectrum BW on a demand basis. They must work within the physical limitations that our current knowledge provides us about the EM spectrum. Working within these limitations chunks of spectrum BW are leased to entities that utilize their allowed BW to conduct a range of operations. As the number of wireless customers continues to rise, new ways to provide adequate BW to these customers must be developed and implemented.

This project arose from a desire to test whether or not a band of EM spectrum could be shared by two entities without significantly degrading either operation. This paper will discuss some background, the S-band interference testing that was conducted, then the overall results and recommendations.

A. ORIGINS OF SPECTRUM MANAGEMENT

The discovery of radio communications has its origins in the labs of many intelligent people whose discoveries led to one of the most important scientific developments in history. Professor Samuel F. B. Morse's early experiments with wireless communication, Thomas Edison's scheme to signal moving trains by induction from telegraph wires, and an urging from one German physicist to another to finally produce some physical evidence that supported Maxwell's Theory of Radiated Power, all led to Heinrich Hertz accidentally discovering electromagnetic waves. The very first radio transmission of a human voice by Reginald Fessenden occurred in 1900, but numerous brilliant scientists were pursuing the development of wireless transmission technology during this time period. Arguably one of the most influential was Charles Marconi whose work has built the foundations of modern students' knowledge in the field of radio frequency communications. Marconi's work in antenna development, such as his discovery that grounding his transmitters improved their performance, and figuring out the increased gain an antenna possesses inherently based on its larger size, laid the foundations for the development of modern wireless transmission capabilities. These discoveries were an enormous undertaking that Marconi developed through years of steadfast testing and analysis. In December 1901, the very first transatlantic signals coursed the airwaves. Utilizing an estimated 10 KW of transmitted power on a transmitter that was two-hundred feet long and one-hundred feet high, a radio signal was sent across the ocean to a five-hundred feet long receiver wire hoisted in the air by a kite [1].

The U.S. Navy was relatively quick in recognizing the potential benefits radio transmission represented in its demanding and wide spread travel on Earth's oceans. Testing of the new transmission technology led the Navy to implement new rules, which equipped their entire fleet with radio transmitters. In support of the newly radio-capable ships, the U.S. constructed a comprehensive support network of ground stations along the U.S.'s coast. The groundwork for what would become an extensive network of electromagnetic wave generating

communications devices was laid, and the future of long distance wireless communication looked to hold limitless potential. From 1900 to 1910, radio technology developed at a steady rate, and the community of EM spectrum users grew immensely [2].

1. The Radio Act of 1910

The U.S. government began to regulate the EM spectrum with the implementation of The Radio Act of 1910. The law required that all ocean-going ships, U.S. or foreign flagged, with a passenger capacity of 50 or greater, needed an “efficient apparatus” for radio-communication. The law also defined terms that the radio must be in good working order, be capable of receiving and transmitting messages, and must be functional at a distance of at least 100 miles. This act set in place important regulations regarding the utilization of the EM spectrum and set a precedent for what would become the International Regulations for Preventing Collisions at Sea. Though the U.S. government could see the need to foray into the regulation of radio transmissions on the high seas, it did not anticipate the problem that EM spectrum management would present [3].

The Titanic was a crowning achievement of its time, modern in most every way except its required radio communications suite. The Marconi radio that was installed onboard was already obsolete by 1912 standards, but because it was onboard with trained operators, the ship met the regulation set by the Radio Act of 1910 [4]. The Titanic departed from Queenstown, Ireland, on 11 April 1912, and three days later, on 14 April, already within range of conducting radio communications with Cape Race, Newfoundland, she hit the iceberg that would be her undoing. Confusion and an obsolete Marconi radio played a large part in the unsuccessful rescue of the Titanic’s crew and passengers. Two separate committees convened in the aftermath of the disaster—one led by a U.S. Senate Committee and the other led by the British Board of Trade—learned of the Marconi radio’s fatal flaw; it could only send one message at a time, it could only take one message at a time, and it could not conduct both of these operations at the same time. There were multiple factors that caused the catastrophe of the

sinking of the Titanic and no single point of blame that can be attributed for failure to rescue the Titanic's crew and passengers. Looking solely at the technological issue of the Marconi radio, it becomes clear that the problem was the spark gap transmitter that Marconi's system utilized (see Figure 1) overwhelmed the frequency bandwidth and interfered with all the other ships within communications range of the Titanic. The main problem with this story is the fact that other more technologically advanced radios were available for use that utilized the more advanced continuous wave (CW) radio transmitters. CW radio transmission style allows for a more precise frequency transmission, within a finite frequency band, by modulating the actual communication onto a separate transmission frequency [2]. EM spectrum was not a regulated sector in radio communications, only the requirements of possessing the means to do so onboard passenger ships was. The Titanic's tragedy played a huge part in opening the eyes of regulatory bodies who saw that a means of governing EM spectrum would be important, especially as the community of EM spectrum users continued to grow.

2. The Radio Act of 1912

The U.S. Congress knew that a system of regulations needed to be established to ensure order within the community of radio users and to prevent mishaps that could arise from spectrum mismanagement. Despite knowing that the regulation of frequency allocation and requiring radio licensing was very unpopular among radio amateurs, the Senate combined aspects of six separate bills and brought forward the Radio Act of 1912 [6]. This set of regulations established requirements that made the world of EM spectrum use and management much more manageable.

From this point forward in history it was required that a person, company, or corporation within the jurisdiction of the United States utilizing radio frequency would have to be in the possession of a license that would be regulated by the Department of Commerce and Labor. What would be a normal wavelength was

defined as one that “shall not exceed six hundred meters or it shall exceed one thousand six hundred meters” [6]. Every operating station was required to designate a definite wavelength that they would be utilizing to send and receive transmissions. The standard SOS signal of distress was defined and regulations regarding the right of way that these signals inherited were created [6]. The beginnings of frequency management were set in place and ways of preventing interference between government/military radio stations and commercial broadcasts were agreed upon. To enable the success of emergency signals all transmissions were required to be sent at the minimum amount of power necessary to be successful.



Figure 1. Re-creation of the Titanic's Radio Room. Source: [5]

3. The Radio Act of 1927

Radio frequency communications continued growing at an exponential rate, outpacing the legislation created by Congress in 1912. The electromagnetic spectrum is a finitely distributed resource, and with the increasing demand and its inability to expand, the management and distribution of spectrum had to evolve. The U.S. Attorney General had decided by 1926 that the Radio Act of 1912 did not give enough authority to the Secretary of Commerce to assign wavelengths and manage much of the chaos in the world of radio frequency. The implication of more legislation was discussed for many years prior to 1927. The American people were very concerned that more radio controls would lead to the Radio Communications Association (RCA), which would attempt to monopolize the potentially million-dollar industry. Free speech and what it represented over the mostly free radio airwaves were intensely debated with the intentions of keeping the airwaves unregulated. Herbert Hoover, then Secretary of Commerce, spoke to the intended regulations, fully believing that radio was a public utility that needed to be double guarded in the interest of the people's homes that the broadcasts were entering. Hoover was an advocate for federal control because he believed that was the only way to control labor unions and corporations, but he also recognized the inherent danger in presenting this control to the Federal government. The demeanor that Hoover possessed assuaged the concerns of many in Congress who knew that he would be the one to oversee the transition of radio control to the Federal Radio Commission [7].

The 69th Congress signed The Radio Act of 1927 into law on February 23, 1927. It was not a perfect bill in terms of the regulations placed on radio broadcasters in the name of "morality," but it introduced legislation to begin the much needed in-depth division and regulation of the EM spectrum. The bill stated:

This act is intended to regulate all forms of interstate and foreign radio transmissions and communications within the United States, its Territories and possessions; to maintain the control of the United States over all the channels of interstate and foreign radio

transmission; and to provide for the use of such channels, but not the ownership thereof, by individuals, firms, or corporations, for limited periods of time, under licenses granted by Federal authority, and no such license shall be construed to create any right, beyond the terms, conditions, and periods of the license[8].

Congress divided the U.S. into five separate zones to assist regulation each presided over by a different commissioner. The Federal Radio Commission (FRC) presided over each commissioner and the attached division. The FRC was now bound by law to meet and provide a number of services. Notably they would “assign bands of frequencies or wave lengths to the various classes of stations, and assign frequencies or wave lengths for each individual station and determine the power which each station shall use and the time during which it may operate” [8]. Thus truly began the U.S. Governments foray into EM spectrum regulation.

B. SPECTRUM MANAGEMENT TODAY

What was the FRC became the Federal Communications Committee (FCC) under the Communications Act of 1934 [9]. To this day, the FCC manages and regulates wireless communications for non-Federal use, such as for state and local government, commercial applications, private internal business, and personal use [10]. A second organization created in 1978, the National Telecommunications and Information Administration (NTIA), manages Federal spectrum use, and serves as the president’s principal adviser on telecommunications policies pertaining to the U.S. economic and technological advancement [10]. Today’s world is full of wireless communications for an ever-growing number of products. The Pew Research Center released the results of a study done in February 2016 that discussed the growing trends of Internet and cellular phone usage around the world [11]. Figure 2 shows the amount of people that reported using the Internet or owning a smartphone.

Most adults in advanced economies use internet, developing countries less so

Adults who use the internet at least occasionally or report owning a smartphone

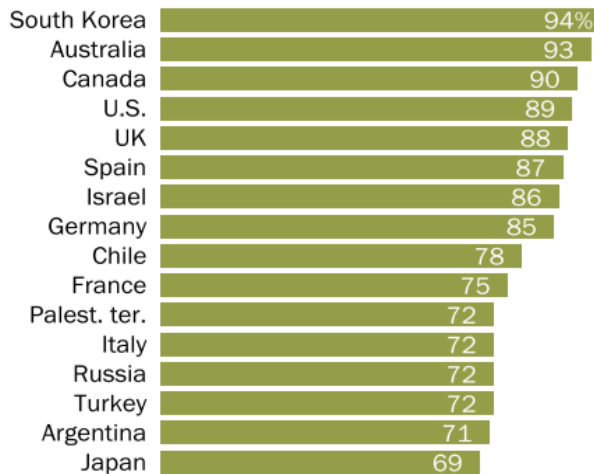

Figure 2. Adults Using Internet and Smartphones. Adapted from [11].

The percentages in Figure 2 are not the entire picture of worldwide Internet and cellular phone usage. With these developed nations' high percentage of EM spectrum users, providing access is becoming more difficult as populations grow and more users from developing nations get onboard with the world's technology.

With the development of advanced and relatively inexpensive wireless technology such as 3G/4G cellular broadcasting and its commercial introduction to the general population, the world saw an extreme increase in the demand placed on the EM spectrum [12]. With the exponential increase in wireless devices now flooding the market (see Figure 3), the companies that provide the wireless services need to expand the access that they have to the EM spectrum, which in turn will provide them the capability of continuing to provide services to the growing customer base.

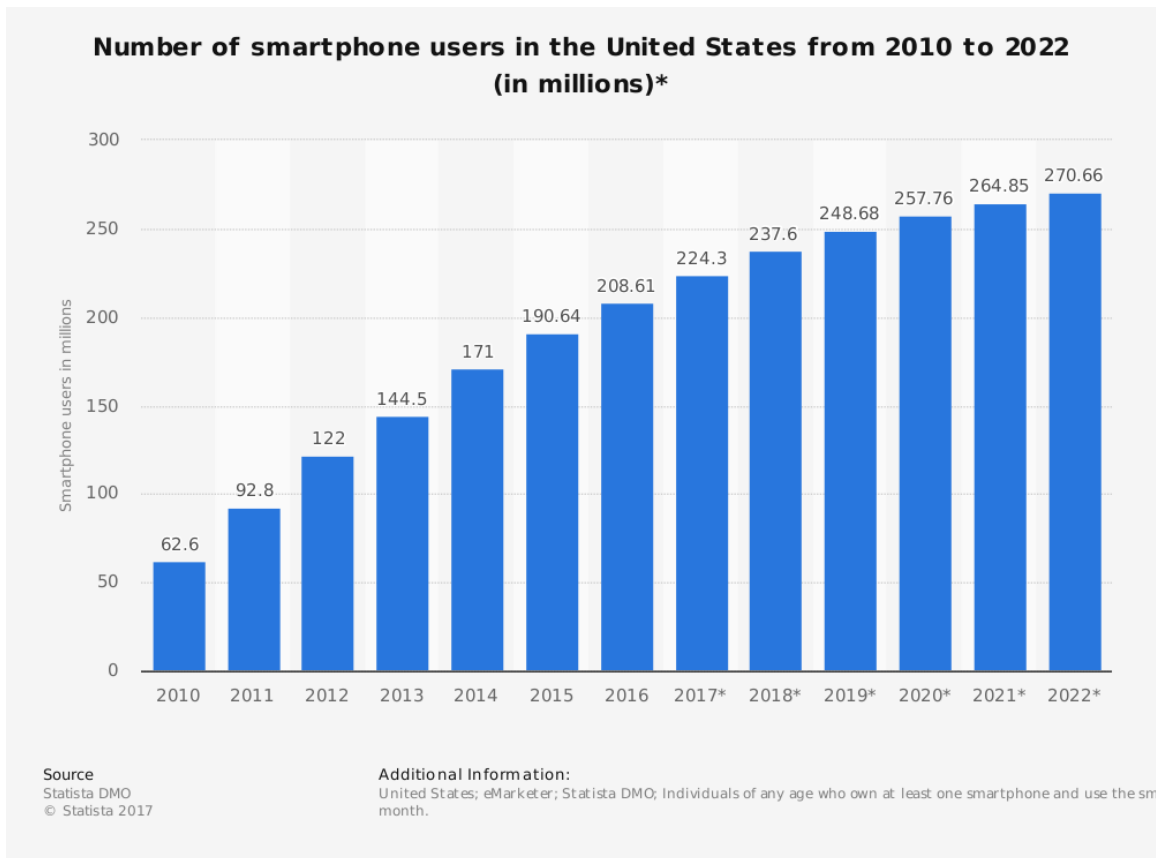

Figure 3. Smartphone Users in the United States. Source [12].

With the data in Figure 2 representing current internet use and Figure 3 displaying how demand for Internet and cellular phone usage is very high and expected to increase, one can deduce a rising issue. This presents a unique and complex problem for all providers and consumers of EM spectrum based broadcasting.

Communications with satellites, commonly referred to as Telemetry Tracking and Command (TT&C), are only done via wireless communications. Satellites have become a prevalent aspect of modern life, as they provide a multitude of services that range from radar imagery, to basic Internet access. Data collected from the Space Surveillance Network (SSN) and compiled by the Union of Concerned Scientists (UCS) in 2015 indicates that we have around 1,300 active satellites orbiting the planet. Looking into the next decade, these

numbers are not expected to decrease just considering two of the new communications satellites projects being developed currently. For example, the OneWeb satellite constellation will consist of 648 Low Earth Orbit (LEO) satellites initially, and SpaceX's unnamed project is going to be composed of 4000 LEO satellites. The intent of these constellations is to deliver Internet service around the world. Another industry that is also growing is the utilization of very Small satellites (SmallSats), particularly those known as CubeSats.

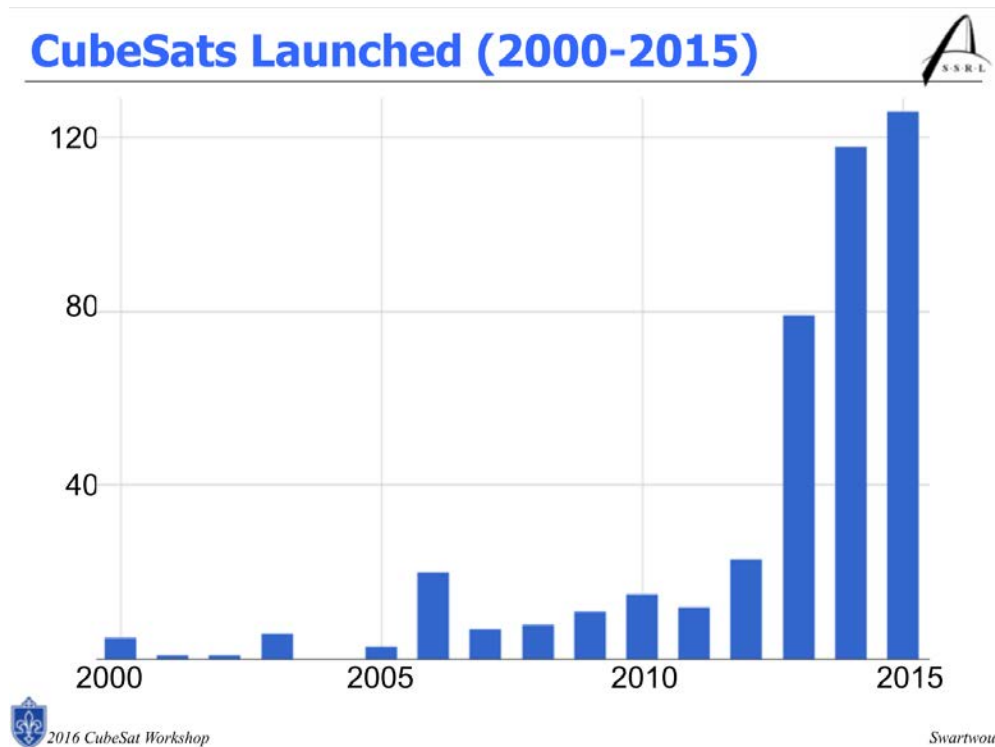

Figure 4. SmallSats Launched. Source [13].

Figure 4 shows the rapid implementation that SmallSats have experienced in a matter of 15 years, most of which has occurred during the last three years of data provided. This data is not the complete story of SmallSats. Figure 5 shows the much larger number of attempts made to get SmallSats into orbit. This demonstrates that there was a much greater desire to get the satellites into orbit

earlier in the life of SmallSat development, which is further evidence to the interest in the advancement of this technology.

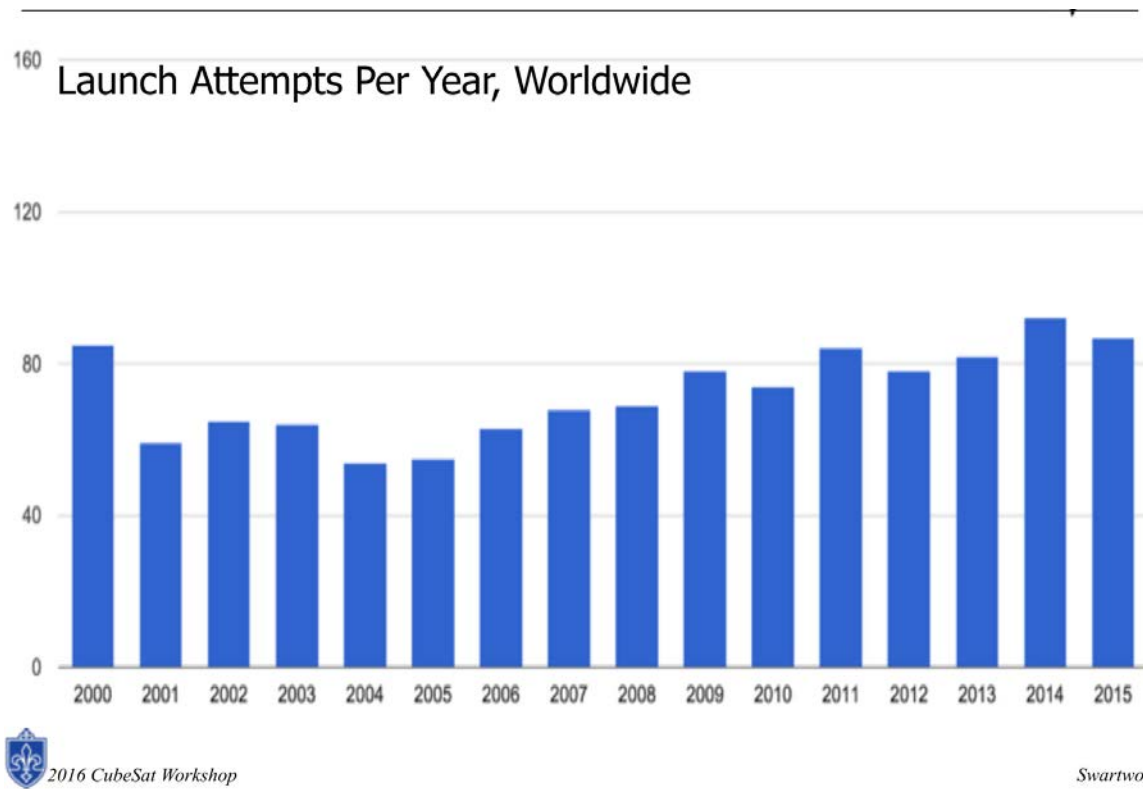

Figure 5. SmallSat Launch Attempts. Source [13].

All of these satellites conduct TT&C utilizing a specified band of spectrum for wireless transmissions with their designated ground stations. In conjunction with numerous other services that conduct wireless communications, the world is now littered with devices that require EM spectrum to conduct their operations. In 2016 alone, worldwide mobile data traffic grew by 63% according to an analysis executed by Cisco [14]. During this same period, 4G connections accounted for 69% of mobile traffic and are only 26% of total mobile connections. The more advanced connections equate to higher data rates thus requiring a larger chunk of bandwidth. The amount of data use is only predicted to continue to skyrocket, exemplified by Figure 6. Wireless communications are growing and all the data

collected points to a similar conclusion: the demand, particularly for cellular wireless technology, will continue to grow. This places an enormous burden on managing and sorting through the use of the EM spectrum. Regulatory bodies have an immense undertaking being placed before them.

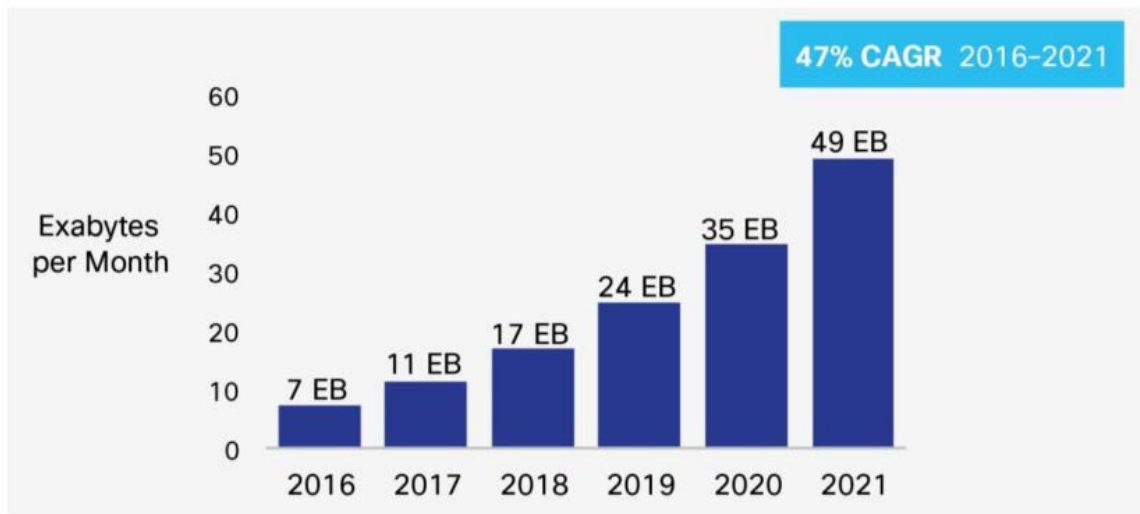

Figure 6. Cisco Forecasts for Mobile Data Traffic. Source [14]

1. EM Spectrum Auctions

Until 1994, the FCC relied upon applicants to go through the process of applying for EM spectrum licenses. This process was often drawn out over a period of a year or more and was not the most efficient process. Resulting from the Omnibus Budget Reconciliation Act being passed in 1993, the FCC began using auctions in an attempt to shorten the time span for authorizing spectrum band licenses, and find, what the FCC called “the most effective users” [15]. The auctions allow a much wider array of customers to be involved in spectrum bidding due to the online nature, and the wait time from initial application to actually getting the license has been shortened on average to less than a year. The Balanced Budget Act of 1997 expanded the FCC’s authority, which gave them the authority to resolve initial applications that would be mutually exclusive by the use of auctions.

The FCC has successfully conducted about 100 auctions since their inception and has generated an enormous amount of revenue for the government [16]. Of particular note is the auction in the 97 block of Table 1 known as the Advanced Wireless Services (AWS-3) auction. This auction took place from November 2014 through January 2015, generated \$41 billion dollars from its sales, and won its bidders 1,611 new licenses. The AWS-3 auction's scope covered 95 MHz of bandwidth in the 1755–1850 MHz frequency range.

Table 1. FCC Auction Examples. Adapted from [16]

Completed Auctions				
Auction Name	Licenses Auctioned	Licenses Won	Net Winning Bids (M)	Rounds
90 VHF Commercial Television 2/15/2011-2/17/2011	2	2	\$2.631	14
91 FM Broadcast 4/27/2011-5/11/2011	144	108	\$8.538	62
92 700 MHz Band 7/19/2011-7/25/2011 Map(s): CMA (Or MSA & RSA) (pdf), Economic Areas (pdf)	16	16	\$19.770	30
93 FM Broadcast 3/27/2012-4/5/2012	119	93	\$3.826	37
94 FM Broadcast 4/23/2013-5/6/2013	112	93	\$4.123	47
95 Lower and Upper Paging Bands 7/16/2013-8/6/2013 Map(s): EA (pdf), MEA (B) (pdf)	5,905	3,104	\$1.659	74
96 H Block 1/22/2014-2/27/2014 Map(s): Economic Areas (pdf)	176	176	\$1,564.000	167
97 Advanced Wireless Services (AWS-3) 11/13/2014-1/29/2015 Map(s): CMA (Or MSA & RSA) (pdf), Economic Areas (pdf)	1,614	1,611	\$41,329.673	341
98 FM Broadcast 7/23/2015-8/6/2015	131	102	\$4.121	51
901 Mobility Fund Phase I 9/27/2012-9/27/2012	14,245	0	\$0.000	1
902 Tribal Mobility Fund Phase I 2/25/2014-2/25/2014	1,004	0	\$0.000	1

This bandwidth was significant for a number of important operations conducted under the federal government. Table 2 lays out the entirety of operations that took place under this cognizance, but of particular import to the discussion at hand is the 269 satellite TT&C operations that operated within the Air Force and the Navy's purview [17]. The AWS-3 auction sold this bandwidth that the DoD used for conducting:

Initial contact with newly launched satellites, early orbit checkout of those satellites, emergency access to spinning/tumbling satellites (anomaly resolution), and final disposal of satellites upon mission completion. This band also supports critical command and control; mission data retrieval; and on-orbit maneuvering of low and medium earth, highly elliptical, geosynchronous, and geostationary satellites. [17]

This bandwidth change was anticipated by federal services, as it was part of The National Broadband Plan issued on March 17, 2010. The plan’s goal was to free up 500Mhz of federally utilized spectrum, so that it could be reallocated to wireless broadband services. Alongside the cognizant agencies, the FCC, and the Policy and Plans Steering Group (PPSG), conducted studies to locate suitable substitutes to allow movement of operations.

Table 2. Federal Assignments in 1755–1850 MHz before AWS-3. Source [17].

AGENCY	Fixed Point-to-Point Microwave	Military Tactical Radio Relay	Air Combat Training Systems	Precision Guided Munitions	Law Enforcement Mobile Video Surveillance Applications	High-Resolution Video Surveillance (fixed or transportable)	Telemetry, Tracking, and Commanding for Federal Space Systems	Air-to-Ground Telemetry	Land Mobile Robotic Video Functions (e.g. EOD & Hazardous Waste Disposal, etc)	UAS, UAV, RPV	TOTAL
Air Force	12		273	1		2	220	186	61	45	800
USAID						1					1
Army	45	408	4			36		19	4	378	894
DHS	152				25						177
DOC	8						1				9
DOE	91								2		93
DOI	26				1	1					28
DOJ					7	75			7	6	95
FAA	8										8
HHS						1					1
HUD						6					6
Marine Corps	4	169								21	194
Navy	14	2	430	20			48	303	6	14	837
OPM						1					1
NASA								6		11	17
Treasury						10					10
USCP						5					5
USPS						3					3
VA						4					4
TOTAL	360	579	707	21	33	145	269	514	80	475	3183

2. Channel-Sharing

Channel-sharing is recent in that its feasibility did not exist until the last couple of decades' technology had developed sufficiently to support such precision operations within the bands of spectrum the FCC leases. Michael Marcus, a retired FCC senior technical advisor, who served as an advisor to the Spectrum Policy Task Force, wrote a paper in 2009 addressing possible situations that could lead to private sector sharing federal government spectrum [18]. Marcus primarily discusses the possibilities of a future third generation of spectrum-sharing between commercial and federal entities. Numerous federal entities widely utilize Radar systems and the possibility of recycling radar spectrum using a timing system, such as GPS to ensure the radar rotations are precisely timed. This timing could be published publicly and allow users to know exactly when and where their systems would not interfere with the radar systems. Marcus also discusses recycling mobile radio spectrum that various entities in the federal government possess to conduct communications in a similar manner to cellular phone communications. He points out that many individual agencies own their bandwidth for individual operations, yet most of the time policy has brought the agencies towards a shared system. Allowing some of the bandwidth that is not being currently and continuously utilized to fall into the commercial sector might bring some prosperity with it. These practices are highly theoretical in nature, and Marcus even admits that these ideas were often disregarded when he brought them up during his time at the FCC.

In 2012, two years before the AWS-3 auction took place, the FCC Report and Order FCC 12-45 [19] went into depth on the conditions and situations that would be conducive and supportive of channel sharing among multiple users. Largely written because of The National Broadband Plan's agenda to free up 500 MHz of federal spectrum, the FCC sought to take the initial steps in amending their rules for sharing broadcast channels, primarily between television stations. This established the ground rules ensuring that channel sharing would be voluntary, flexible and supportive of the rights of the channel sharers.

Two television stations out of Los Angeles conducted a test and analysis of channel-sharing in March of 2014 [20]. KLCS and KJLA assembled their individual teams, and they endeavored to test the feasibility of sharing a single 6 MHz radiofrequency channel. The ultimate goal was to create a scenario utilizing their equipment and conduct tests that were strictly technical in nature, not produce a supportive or dismissive document. Neither television station wanted to produce an intensive look into the legal aspects of conducting an action such as sharing bandwidth. The result was a highly successful experiment that demonstrated that these two stations could share the 6 MHz channel and successfully stream 2 HD (720p) signals in addition to two additional SD streams without a major impact to the quality of their provided experience. Their empirical data showed the following in Figure 7.

- Channel sharing on both a physical and virtual level (PSIP)¹ can be done.
- On the virtual level, we found that all the TVs and tuners tested were able to receive and correctly parse all the required information. This included virtual channel, both major and minor, ratings, audio configuration, codecs, program titles and descriptions. The test results also suggest that careful thought must be put into the transition, whether for repacking or sharing, by the FCC and broadcasters to find a solution that will ensure a positive viewer experience.
- On a physical level, testing demonstrated that it is technically feasible for two 720p high definition (“HD”) streams to be combined into a single Advanced Television System Committee (“ATSC”) channel.² Results clarify that stations wishing to channel share must consider: (1) whether to utilize fixed or dynamically allocated bitstreams between the parties; (2) the relative “digital complexity” of the video content to be transmitted by two parties; (3) how to govern the division of the bitstream based on those requirements; and (4) how to monitor and manage any agreement reached on sharing of the bitstream itself.
- Testing demonstrated that it is technically feasible for the 2 HD (720p) streams to be combined with several variations of additional SD program streams. We observed that up to two additional SD streams are possible without major impact to the quality of experience of the overall material. While more SD streams are possible, multiplexing additional SD streams will likely require limiting the bitrate of the SD streams to avoid impacting the Quality of Experience (“QoE”) of the HD programs. Stations need to test any increased program count carefully and fully optimize the statmux parameters for this to work.
- Three HD streams were also combined onto a single ATSC channel. Testing found that this combination may be technically feasible and of value for broadcasters, but each entity needs to examine the digital complexity of their material and decide if this combination is acceptable for their viewers.
- One HD stream is possible with a variety of SD programs. We tested 1 HD and up to 7 SD streams in a single ATSC channel with good results. The complexity of the content will determine the final program count.
- Bandwidth management (allocating the bitstream among a variety of services, metadata, video and audio) must be determined upfront for channel sharing to work properly. Our testing demonstrated that new encoders not only are more efficient in bit utilization but dramatically improved the QoE as well.
- Finally, additional areas of future study would include: (1) H.264 decoding and (2) ATSC 3.0 implications. We found that some consumer televisions decoded H.264 off-air. While this data is anecdotal, if the majority of future television sets can utilize H.264, greater bandwidth efficiency and/or quality of experience may be possible. H.264 offered a 10-15 percent greater efficiency in bitrate utilization.

Figure 7. KLCS/KJLA Channel Sharing Pilot Results. Source [20].

THIS PAGE INTENTIONALLY LEFT BLANK

II. S-BAND RADIO FREQUENCY INTERFERENCE TEST

A. INTRODUCTION

The SmallSat community is still in its infancy and as previously discussed, experts in this field predict that it will continue growing over the next decade at an alarming rate. From 2017–2026 the “Prospects for the Small Satellite Market-2017” report anticipates the launching of over 6,200 SmallSats, potentially seeing this \$8.9-billion-dollar industry grow into a \$30.1-billion-dollar industry [21]. With the growing world of mobile cellular technology, and their respective companies building on that growth, they require for more chunks of the EM spectrum to continue their operations. With this growth of industry, it is becoming more relevant to consider venturing into the realm of EM spectrum sharing. The feasibility has been documented by the KLCS/KJLA Channel Sharing Pilot Results that have been included in Figure 7 above. More testing is required to ensure various conditions and situations are tenable when utilizing shared EM spectrum bands.

To ensure satellites’ health, status and vehicle/payload control are maintained and functional for the life of the satellite, continuous and ongoing Satellite Operations (SATOPS) TT&C are performed. The DoD has traditionally performed SATOPS functions utilizing the Space Ground Link Subsystem (SGLS) waveform via L-band (1761-1842 MHz) uplinks and S-Band (2200-2290 MHz) downlinks. As discussed previously, when the FCC held the AWS-3 auction the DoD lost the capability to perform TT&C for 269 various SATOPS managed by DoD in the L-Band [17]. Moving DoD SATOPS previously performed in the L-Band to the Unified S-Band (USB) has been identified as an acceptable substitute. The DoD has considered this move for over a decade and will not result in significant impacts to operations. USB can offer several advantages for SATOPS specifically: lower path losses; a more reliable link closure under various conditions; and the capability to utilize commercial off-the-shelf (COTS)

hardware, which can reduce costs and provide an easier learning curve for smaller operations within universities and DoD platforms.

Conducting SATOPS utilizing USB for TT&C is an ongoing operation in today's science community as well as being utilized by NASA for their dedicated command and control uplinks. The concept is proven by operation and it is not a new technology that would have to be introduced to an already inflated DoD budget. Utilizing USB to conduct TT&C for SATOPS is almost an easy move with minimal effort in the realm of DoD operations. DoD assets are not the only customers targeting USB and there is one thing to consider before operations can be conducted. The primary user of USB is the commercial broadcast auxiliary service (BAS), which utilizes this spectrum band to perform electronic news gathering (ENG) operations within the U.S. ENG operations are basically the transmission of digital video/audio signals from a mobile platform to a fixed receiving station. Figure 8 shows that the USB bandwidth is assigned by the FCC to both space operations/research and to television auxiliary broadcasting [22]. This is not a direct stop all for continuing forward in the process of utilizing the USB for DoD purposes, but it must be acknowledged that the BAS is the primary user and they have regulatory supremacy for the bandwidth.

2025-2110 SPACE OPERATION (Earth-to-space) (space-to-space) EARTH EXPLORATION-SATELLITE (Earth-to-space) (space-to-space) FIXED MOBILE 5.391 SPACE RESEARCH (Earth-to-space) (space-to-space)	2025-2110 SPACE OPERATION (Earth-to-space) (space-to-space) EARTH EXPLORATION-SATELLITE (Earth-to-space) (space-to-space) SPACE RESEARCH (Earth-to-space) (space-to-space) FIXED MOBILE 5.391 5.392 US90 US92 US222 US346 US347	2025-2110 FIXED NG118 MOBILE 5.391 5.392 US90 US92 US222 US346 US347	TV Auxiliary Broadcasting (74F) Cable TV Relay (78) Local TV Transmission (101J)
5.392	Page 36		

Figure 8. FCC Table for USB License. Source [22]

Following in the footsteps of NASA, who has had relatively little trouble coordinating their use of the USB with the commercial broadcast community, the testing conducted at the Naval Postgraduate School (NPS) set out to determine the potential impact to local BAS operations, and determine what conditions would allow for SATOPS to be conducted simultaneously along with the ENG

operations being performed in the Monterey/Salinas California area. Utilizing NPS' Mobile CubeSat Command and Control (MC3) ground station, which was S-band ready, operational, and located in an ideal geographical region, radio frequency interference (RFI) testing was conducted. The operations conducted are the first controlled set of tests to evaluate candidate SATOPS uplink RFI mitigation measure on ENG operations. The baseline of evaluation, methodology and procedures that will be established will allow further research and development into spectrum sharing. This methodology can then be used to conduct EM spectrum sharing testing among various other communities and operations paving the way into a much more knowledgeable EM spectrum consumer community.

1. Coordination

NPS coordinated all testing activities to ensure no interference with any current ENG operations taking place over the test period. Establishing an environment conducive to the sharing of information, which lends to the prevention of any RFI between participants, is of the utmost importance to ensure the smooth operations of any future endeavors. The following authorities were communicated with

- The Society of Broadcast Engineers (SBE) representative, Ron Thompson
- Local television station KION station manager, Kristy Santiago, and ENG engineer, Adam Perez.
- Alion group: David Alianti, Michael Dion, Janet Browning, and John Chenevey
- NPS coordinators: David Rigmaiden, Giovanni Minelli, LT Austin Forbes (the author)

2. Objectives

Accomplishing the following for the SATOPS measurement tests:

- Characterization of NPS SATOPS 3-meter S-band terminal antenna pattern.

- Conduct analysis of the impact of SATOPS uplink signals from NPS, on the operations of KION-TV ENG operations being broadcast to Mt. Toro, Monterey, CA.
- Evaluate test results and develop measures to minimize/negate impact on ENG operations from NPS SATOPS.

B. MOBILE CUBESAT COMMAND AND CONTROL OVERVIEW

The MC3 network is a simplified network of ground stations that the Naval Research Laboratory (NRL) jointly developed with NPS in order to support government experimental Colony II CubeSats. Given the ever-increasing budget constraints being placed upon government operations, the DoD has been investigating the use of CubeSats as a less expensive alternative to be used in conjunction with or perhaps to replace multi-million dollar satellites. With the progression and miniaturizing of technology, the usefulness of CubeSats has been demonstrated over the last decade in atmospheric/weather analysis, biological studies, communications testing, and space weather studies [23]. With the increasing number of CubeSats being launched into orbit, and the predicted expansion of CubeSats to come over the next decade, the MC3 ground station nodes are an ideal answer to handle the increase in SATOPS TT&C. MC3 utilizes Commercial-Off-the-Shelf (COTS) hardware along with Government Off-the-Shelf (GOTS) software to create a reliable and easily accessible entry level ground station.

1. MC3 Network Geography

The MC3 network currently consists of operational (op) and in-development (id) ground stations located around the United States:

- University of Hawaii (op)
- Naval Postgraduate School (op)
- Utah State University (op)
- University of New Mexico (op)
- Air Force Institute of Technology. (op)
- United States Naval Academy (id)

- United States Coast Guard Academy (id)
- University of Alaska Fairbanks (id)

Figure 9 lays out the basic locations of the ground stations. More specific information on each ground node can be obtained by contacting the NPS Space Systems Academic Group (mc3@nps.edu).



Figure 9. MC3 Ground Stations. Source: [24].

2. MC3 Equipment

While all ground stations in the MC3 network have similar capabilities and do support the same functionality, not every station has the same equipment installed. The following is a brief overview of the systems installed and operated at NPS that were used to conduct the RFI testing.

The 3-meter S-band antenna, installed on the roof of Spanagel Hall (building 232) on the NPS campus, operates in the frequency ranges of 2025–

2110 MHz Tx, and 2200–2290 MHz Rx. The reflector and feed are commercial while the dish mount and S-band Feed mounts are custom built.

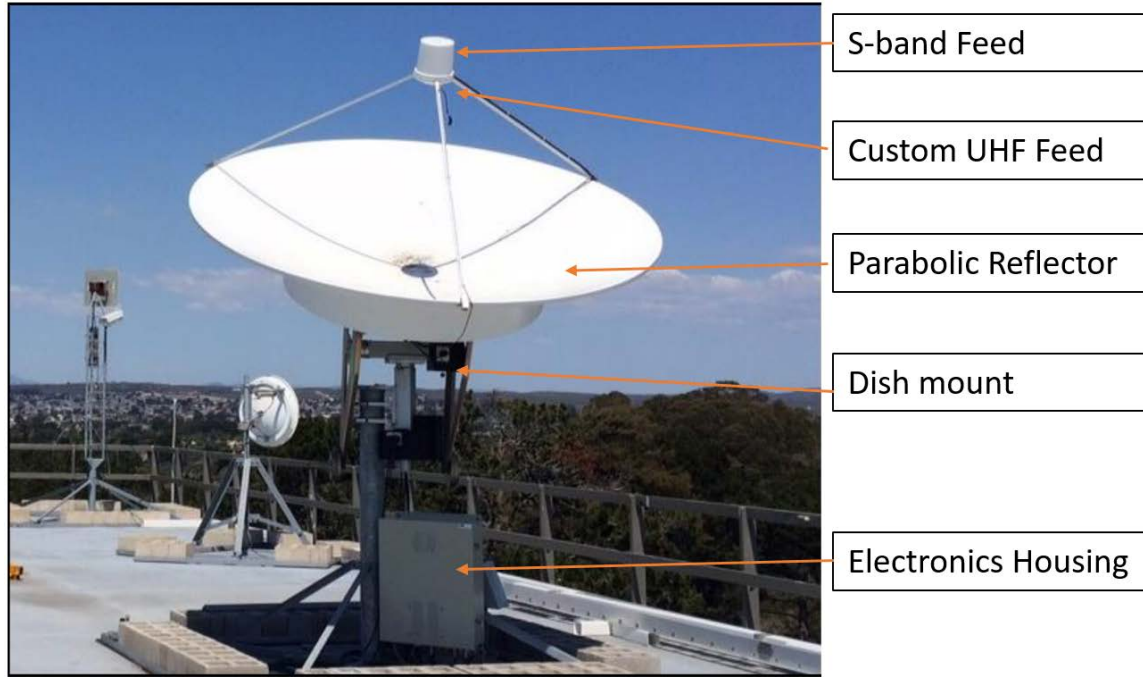

Figure 10. 3-Meter S-Band Antenna

The 3-meter antenna's primary receiver is a National Instruments USRP 2922 software-defined radio. This two channel receiver can have two antennas simultaneously connected (400 MHz - 4 GHz). Table 3 lays out the 3-meter antenna's basic information.

Table 3. Three-Meter Dish Basic Information. Source [25].

Diameter	3 meters
Mainbeam Gain	33 dBi
Sidelobe Gain	15 dBi
Minimum Transmit Elevation Angle	5°
Feedpoint Height above ground level	15 meters
Coordinate	36°35'41.99"N 121°52'28.88"W

The software that currently runs the 3-meter antenna is operated out of the Satellite Ground Station Lab in Bullard Hall at NPS. An MC3 laptop or desktop computer utilizes the SATRN Software, which provides the graphical user interface (GUI) to interact with and monitor current system parameters.

Figure 11 lays out the basic SATOPS ground terminal configuration. To create the required bandwidths for the tests, various GNU Radio scripts running on a laptop computer programmed the SDR to produce BPSK signals. Filtering the SDR output through a bandpass filter (Reactel 7CX9-2067.5-X85N11) ensured the elimination of undesired signals before the signal was applied to a 50dB, 30 W power amplifier (Mini Circuits ZHL-30W-25S+). The antenna system (M2 Antenna Systems FGAE1000SWS) consisting of the 3-meter parabolic dish mounted on a 2-axis (azimuth and elevation) positioner then receives the amplified signal. The generated test signals had left-hand polarization applied through the circular polarization port of the feed (Seavey ESA-22C/N), which generated a circularized right-hand polarization from the antenna reflector.

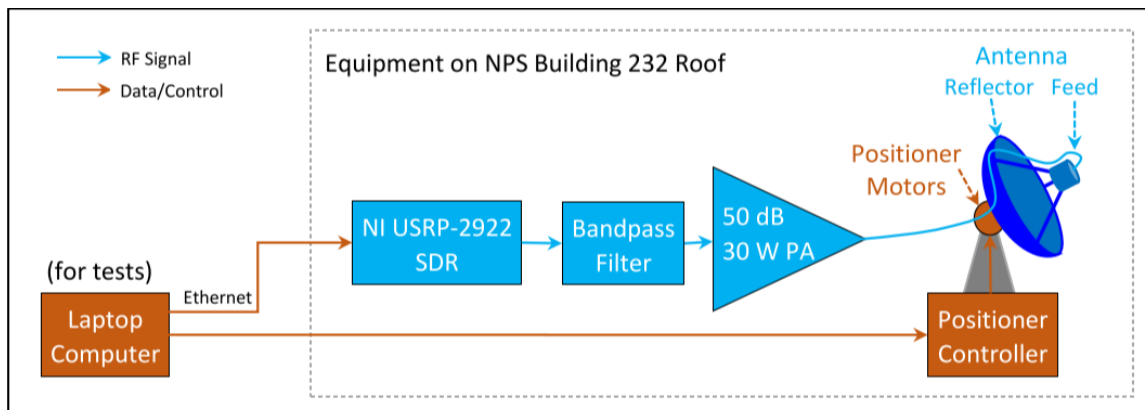

Figure 11. Ground Terminal Configuration. Source [25].

3. ENG Introduction

ENG has been utilized to gather and disseminate the news with portable cameras and/or microphones for decades now. Being introduced in the 1960s, the system was not efficient or as advanced as utilizing studio-based cameras.

Modern technology allows today’s news reporters to gather and disseminate current events from remote locations utilizing mobile platforms such as vans or helicopters, and transmit their digital signals back to their centralized receiver. Typically, the centralized receiver is located in an elevated location like a mountain top or at least in a location that can be easily broadcasted to from the mobile platforms. Once the electronic signal of the broadcast is sent back to the centralized receiver the signal can then be sent on to the main news station either directly or through a satellite link, depending on the distance from central receiver to news station.

As with the previous discussion on EM spectrum management, the ENG operations under the BAS have been assigned seven channels in the U.S. to transmit and receive their RF signals between 2025–2110 MHz as depicted in Figure 9. These seven channels are each 12 MHz in bandwidth (BW) and each segment of spectrum is centered at a 12 MHz frequency increment between 2031.5 and 2103.5 MHz. When conducting ENG operations the broadcast entity has two options to choose from as modes of operation:

- Operate in a centralized 8 MHz band within the 12 MHz BW
- Operate in a 6 MHz upper or lower half band that is split in the middle of the channel.

Figure 12 lays out the ENG operating BW and the channel plan within it. Of note, there are two response channels annotated in purple at the top and bottom of the BW that are 500 kHz response channels. These narrowband channels are designed to facilitate the link establishment between the mobile platform conducting ENG and the central receiving site.

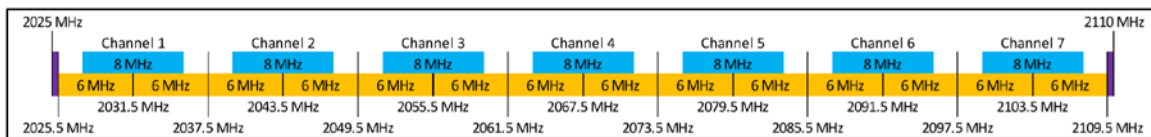

Figure 12. ENG USB Spectrum Channel Layout. Source [25].

4. ENG Equipment

KION-TV uses a central receiving site located on the Top of Mt Toro. This site can receive transmit signals from one of two separate transmitters: one located in a mobile news van, and one located at a fixed location in Monterey, CA. See Figure 16.

Included in the receive site configuration on Mt Toro are two receiver units with model numbers CR6D which do not reflect the fact that the newer CR7 units are installed in the system. Two antenna arrays are configured onto the antenna mast on site; one is a steerable, directional antenna system (Proscan DR III), the other is an array of four 90-degree sector beam antennas (Sectorscan SEC 13–2V-NLNF). The steerable antennas are connected to the CR6D receiver units and have a nominal gain of 26 dBi. The sector beam antennas connected to the CR7 receivers have a nominal gain of 13 dBi and are the only antennas that were utilized during the RFI testing. Figure 14 has a line diagram of the system layout for the receive site, and Figure 14 is a photograph of the Mt Toro site equipment.

Both the mobile van and fixed transmitting equipment have a NuComm ChannelMaster Tx transmitter connected directly to the antenna. The telescoping mast on the mobile van-mounted configuration has both a steerable, directional antenna, and an omnidirectional antenna. At the top of the mast is the larger steerable antenna, and the disc shaped omnidirectional antenna is below. When conducting the RFI testing with the mobile van, the steerable antenna was utilized and the test pattern was transmitted on Channel 4. There is only one antenna, permanently facing Mt Toro, mounted on top of a building rooftop at Fisherman's wharf in Monterey. When conducting the RFI testing utilizing the fixed antenna, a live video feed was being broadcast over BAS channel 5. Figure 16 includes two photographs of the ENG transmitting platforms.

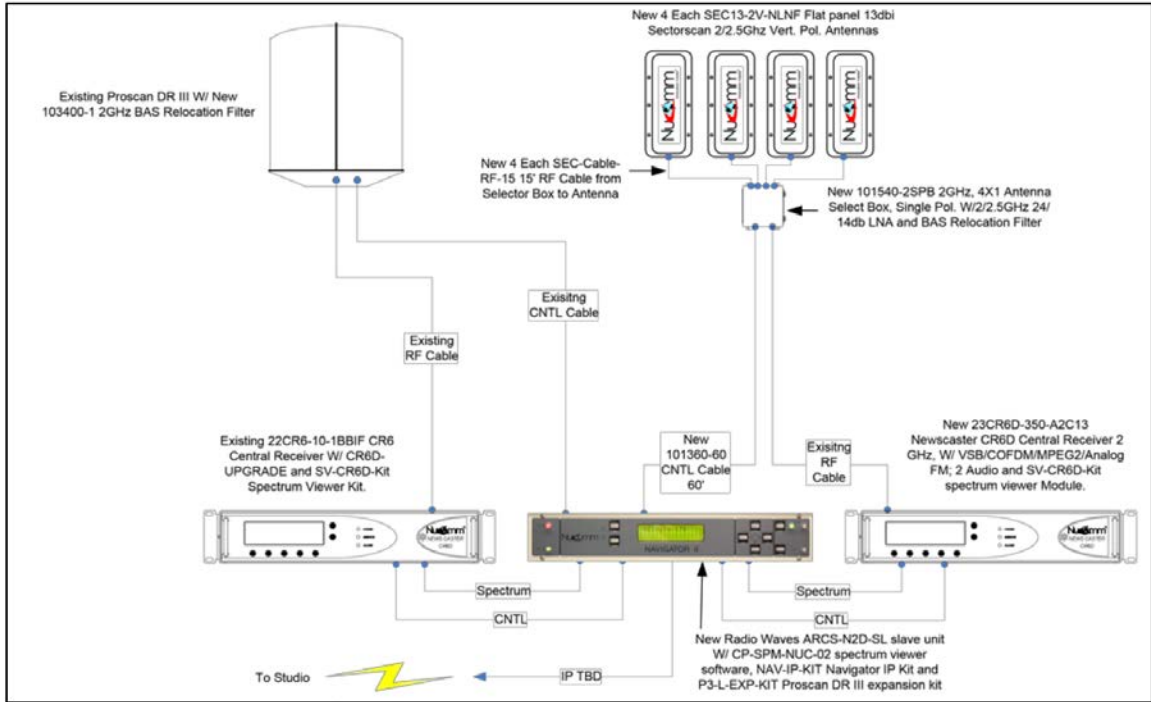

Figure 13. Mt. Toro KION-TV Central Receive System Configuration. Source [25].

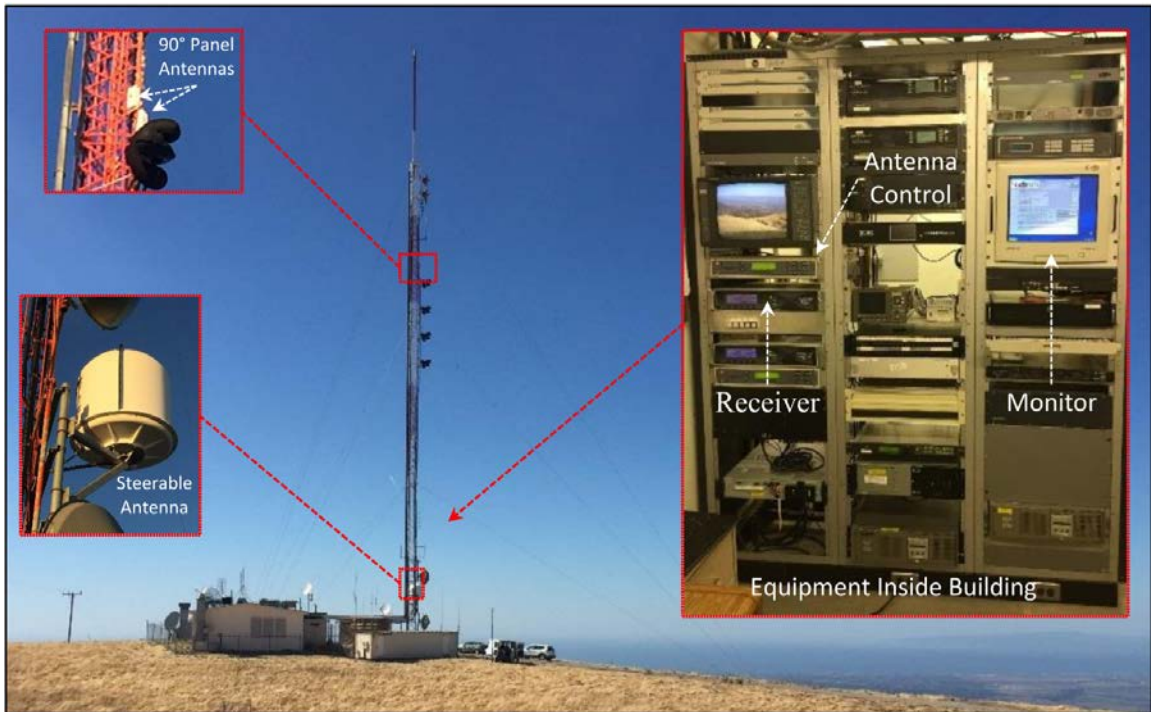

Figure 14. Mt. Toro Central Receive Site. Source [25].



Figure 15. Mobile and Fixed ENG Transmitters [25].

C. RFI TESTING

1. Site Geometry

Figure 16 lays out the relative locations of the involved equipment (NPS Terminal, Mt Toro Receive site, KION fixed transmitter, and KION mobile van) and facilities using Google earth to demonstrate the site geometry, path profile and distance between the locations. It has a slope progression chart to represent the amount that the land altitude changes from the transmitter and NPS terminal to the receiver on top of Mt Toro. Figure 17 provides a closer look at the geometry between the two transmission sites and the NPS terminal. Table 4 provides the coordinates for our locations.

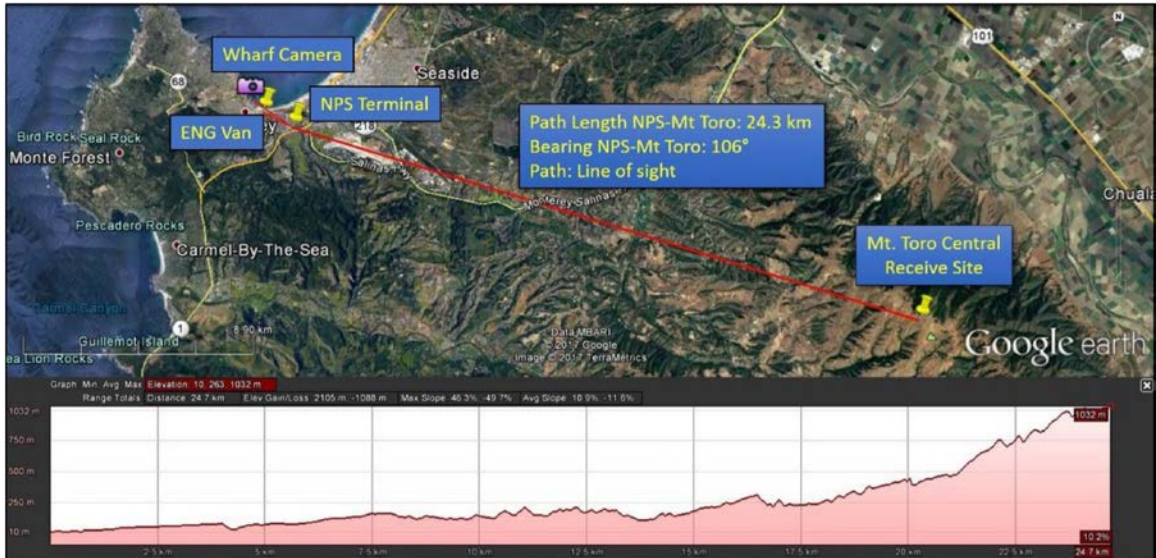

Figure 16. NPS to Mt. Toro Terrain. Source [25].



Figure 17. ENG, SATOPS Transmitter Locations. Source [25].

Table 4. ENG Test Locations. Source [25].

Site	Latitude	Longitude	Distance to Mt. Toro, km	Bearing to Mt. Toro
Mt. Toro Central Receive Site	36°31'51.34"N	121°36'52.15"W	N/A	N/A
NPS SATOPS Ground Terminal	36°35'41.99"N	121°52'28.88"W	24.3	106°
KION-TV ENG Fixed Camera feed at Fisherman's Wharf	36°36'16.44"N	121°53'32.78"W	26.1	108.2°
KION-TV ENG Mobile Van	36°36'0.57"N	121°53'14.33"W	25.5	107.6°

2. Spectrum Measurement

In order to monitor and analyze the signal that the NPS terminal was transmitting, there was a van with test equipment configured at the central receive site on Mt. Toro, as demonstrated by Figure 18. This collection suite allowed the NPS terminal antenna pattern to be characterized and provided the test team a continuous means to monitor the signals being broadcasted at the receive site.

In order to capture all of the signals and record them on a laptop computer, a horn and LNA were mounted on top of a telescopic mast that was then raised to 20 feet in height. This ensured that there would be no obstructions and a clear line of sight (LOS) was maintained to the transmission sites. The mounted Horn had an intrinsic 3 dB beamwidth with a 40-degree opening it was fairly easy to adjust the pointing direction towards the NPS terminal transmission site. A bandpass filter was installed after the horn to eliminate out-of-band emissions and prevent LNA compression. Figure 20 is a basic line diagram of the equipment utilized.

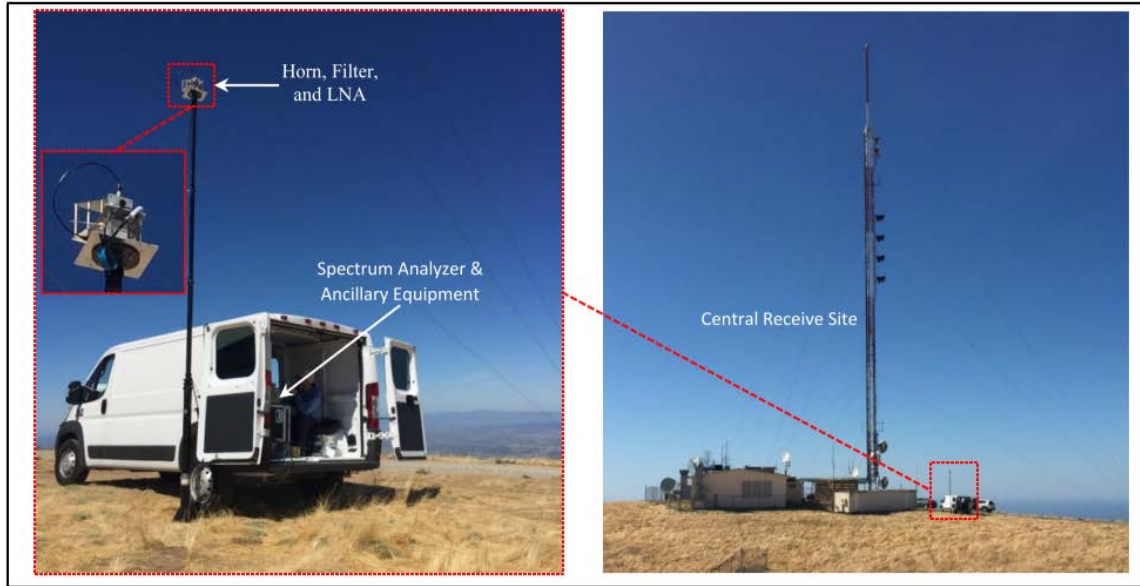

Figure 18. EM Spectrum Analysis Equipment. Source [25].

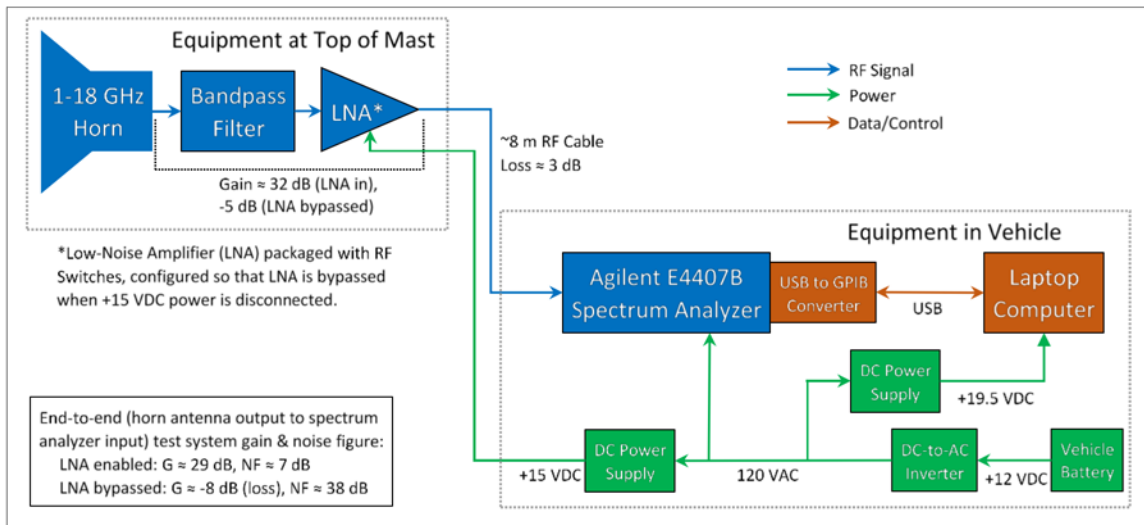

Figure 19. EM Spectrum Analysis Equipment Diagram. Source [25].

Performing sweeps of the measurement cables/connectors in the RF chain before and after any measurements were analyzed normalized the measurement results. Because this measurement system can induce different levels of gains or losses, 29 dB was subtracted from the levels measured on the spectrum analyzer if the preamplifier was enabled. If the preamplifier was

bypassed 8 dB would be added to the spectrum analyzer measurements. The LNA could be utilized or bypassed by disabling the 15V power supply (labeled in Figure 20) depending on the expected receive signal strength.

3. Constraints

The ENG RFI testing was conducted over the course of three days with two days of actual testing. Managing the time coordination with the KION-TV engineer was the top priority due to previous job commitments. The KION engineer volunteered his time to conduct this study with the test team so optimizing the time spent on analysis and what analyses would be conducted was of the utmost priority. Discussions held with the KION engineer and the test team did ultimately result in consensus that two days was a reasonable timeframe to conduct the testing.

Within the operating area that was displayed in Figure 17, the line of bearing (LOB) that existed between the ENG transmission sources, the NPS terminal, and the KION central receive site did prove to be optimal in the sense that the LOB was clear and the distance was not stressed to the point of creating a disadvantaged link. This was one of the most ideal testing situations that could be created because the NPS SATOPS terminal is one of a few DoD SATOPS terminals in the area that can operate in the S-band uplink frequency. Further testing would be required to explore constrained link situations that involve further distances and/or more terrain interference.

Another obstacle in conducting these operations was the lack of standardization when it comes to DoD SmallSat operations and commercial SmallSat operations. DoD SATOPS, in the realm of SmallSats, is in its infancy so the process of standardizing procedures and technical specifications is not yet defined. Because of the lack of standardization, the ENG RFI testing conducted was done in various bandwidths utilizing Binary Phase Shift Keying (BPSK). This is a fairly common waveform utilized in S-band SATOPS, and it is the least

spectrally efficient. This allowed the opportunity to commence the testing and get results that would be indicative of the worst case data rate.

4. Testing Communications

To allow for timely and reliable communications between all test sites involved, cellular phone communications were tested to be operable at all sites. This proved to be a continuously dependable form of communication and allowed everyone to have access to communications without the need for additional equipment. Every test site had at least two cellular phone users ready to communicate.

5. NPS 3-Meter Antenna Pattern Characterization

Conducting an analysis of the NPS terminal's 3-meter S-band antenna was an extremely important aspect of being able to conduct the ENG RFI testing accurately. Knowing the details and qualities of the NPS terminal's emission provides the signals characteristics, which allows decisions to be made based on factors such as reflections and near-field effects that might be unique to an on-site feature. These can prevent the RFI testing from succeeding because the calculated pattern, or the manufacturer's measured pattern, is not completely accurate in every scenario.

The pattern measurements were conducted by recording the CW RF signal from the NPS terminal. Both azimuth and elevation measurements were completed. To conduct the analysis, a 2073.5 MHz frequency that was CW was used and located in between the testing channels of 4 and 5.

The azimuth testing was conducted with the NPS terminal facing true north, at an elevation of 2.4 degrees. Rotating the antenna in the clockwise direction, at a rate of three degrees per second, for a full 360 degrees, the signal that arrived at Mt Toro was recorded on the collection equipment's spectrum analyzer that was set in zero span mode.

The elevation testing was conducted immediately following the azimuth tests, which kept the antenna at the preset 2.4 degrees. The antenna was raised from 2.4 to 90 degrees while recording the data on the collection equipment's spectrum analyzer. A final off-axis measurement was taken at both 5 and 10 degrees' elevation angles while remaining at the azimuth's boresight.

6. RFI Measurement Responsibilities

Participant Responsibilities [25]:

- Test Director
 - Overall test direction
 - Coordination between all parties supporting testing
 - Assurance/recording of proper test conditions
 - Recording of ENG RFI Link metrics
- KION-TV ENG Test Engineer
 - Ensure integrity and operation of wharf and van ENG links
 - Operation of van/ENG link on day two of testing
 - Instruction on operation of ENG receiver equipment
 - Mt. Toro site access
- Test Engineers
 - SATOPS antenna characterization
 - Monitoring, recording and verification of desired ENG link and SATOPS undesired signal levels, waveform and BW as received at Mt. Toro.
- NPS SATOPS Ground Terminal Operator
 - Operation of SATOPS antenna system

- Transmitter operation-SDR programming to ensure correct power, waveform and BW of transmitted signals.

7. ENG Signal Quality Metrics

Before the ENG RFI testing began the installed NuComm receiver equipment at the central receive site was utilized to conduct an initial observation and evaluation of the already established signals being used by the KION-TV site on Mt Toro. This allowed a baseline to be established without the presence of the transmitted signals from the NPS terminal. Figure 20 and 21 demonstrate the equipment and the data that was displayed.



Figure 20. ENG Antenna Controller (NAVIGATOR II) and Receiver (NuComm Newcaster CR7). Source [25].

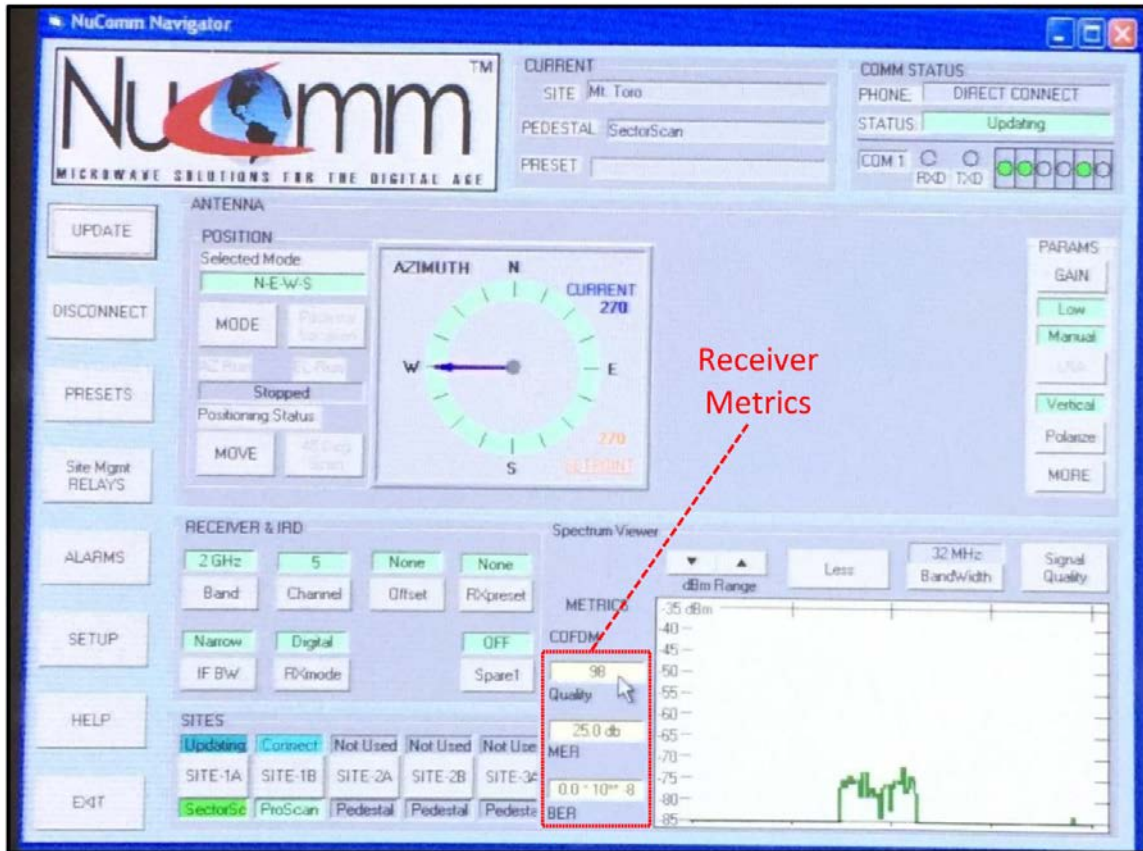

Figure 21. ENG Receiver Interface Screen. Source [25].

Utilizing these two display screens the following information could be obtained to set the baselines:

- Received carrier level (RCL), in dBm
- Bit error rate (BER)
- Modulation Error Ratio (MER), in dB
- Link quality, in %

Figure 22 shows a screen that displays a video either consisting of the test pattern from the ENG van or a live video from the fixed site in the wharf. Figure 21 and 22 were displayed on the same unit and could be switched manually.



Figure 22. Live Video Feed from Wharf. Source [25].

8. ENG NuComm CR-7 Receiver

In order to ensure the most reliable link closure, the KION-TV Engineer was consulted as to the most frequently used and dependable setup when utilizing the NuComm receiver. The GUI on the receiver was used to make sure the following setup was utilized [25]:

- Band: 2 GHz
- RF Mode: Digital
- Modulation: coded orthogonal frequency division modulation/ quadrature phase shift keying (COFDM/QPSK)
- Gain: low

- Intermediate Frequency (IF) Bandwidth: Narrow (trial effects were observed on other available settings)
- Antenna: 90-degree panel/low gain
- Azimuth: 270 degrees
- Polarization: Vertical
- Encoding: Forward error correction (FEC) ½ rate
- Offset: non (non-split channel)

Of note was that the 90-degree panel antennas were chosen based on the analysis that they are the more RFI vulnerable and link disadvantaged.

9. Test Conditions

The ENG link metrics were recorded under the following conditions [25]:

- ENG desired signal:
 - Channel 5 signal from fixed transmitter
 - Channel 4 signal from mobile transmitter
- ENG link state:
 - Acquired and locked with approximately 100% link quality prior to the introduction of the SATOPS signal
 - Link Acquisition after the introduction of the SATOPS signal
- SATOPS transmitter power: 30 W
- SATOPS Modulation
 - CW
 - BPSK
- SATOPS modulated uplink bandwidths: 1, 2, 3, 4, and 5 MHz

- SATOPS modulated center frequency: 2073.5 MHz (middle of channel 4 and 5.)
- SATOPS CW signal center frequency 2073.5 MHz
- SATOPS antenna pointing: 106 degrees' azimuth; 5, 10 degree elevation angle
- SATOPS antenna polarization: right-hand circular

The ENG and SATOPS uplink signals were analyzed utilizing the spectrum measurement equipment that was noted in Figure 18 and 19 and setting the spectrum analyzer to the following conditions [25]:

- Resolution bandwidth: 30 kHz
- Video bandwidth: 300 kHz
- Sweep time: 44.065 ms
- Trace points: 1001
- Detector: Average (RMS)
- Trace averaging over 100 sweeps.

Figure 23 shows the plotted values for the ENG and SATOPS signals that were recorded and calculated at the antenna output connector. The SATOPS channel power calculation has -49 dBm on all bandwidths. The ENG signal on Channels 4 and 5 were calculated to have a -67 and -72 dBm respectively. During the RFI testing for ENG, the carrier-to-interference ratios (C/I) were observed to have approximate values of -18dB and -23dB on Channels 4 and 5 respectively. C/I ratios should remain static despite the various inherent properties of communication equipment, such as different antenna gains and cable losses. As the ENG signal varied during the testing it was noted that the C/I ratio varied as well.

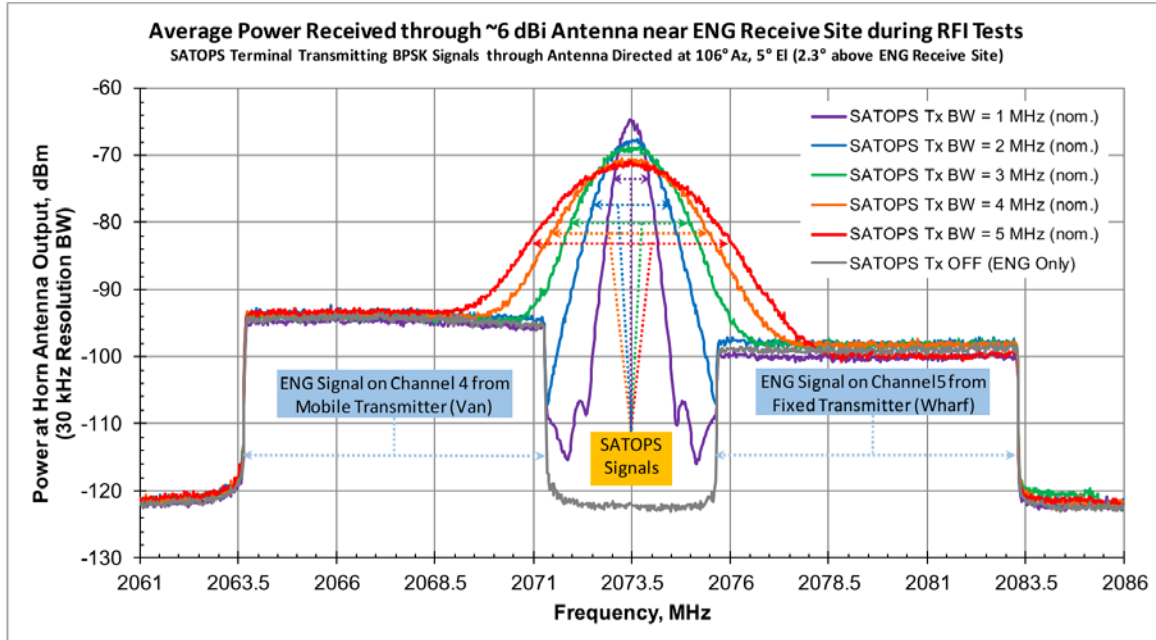

Figure 23. RFI Testing Monitored Signals. Source [25].

10. An Unexpected RFI Testing Opportunity

During the first test, the engineers were located at the Mt Toro central receive site, while the KION-TV engineer was located at his TV station to operate the fixed ENG location in the wharf. After the antenna pattern measurements were done and before the testing could commence, the test engineers noticed that the ENG signal had accidentally tuned to the lower half of Channel 5 with an 8 MHz BW instead of being tuned to the middle of the 12 MHz channel 5 as intended. This resulted in the ENG signal overlapping into Channel 4 by 2 MHz. Instead of immediately correcting this error, the test engineers conducted a few RFI tests setting the NPS antenna to transmit at an azimuth of 106 degrees while moving the elevation angle between 5 and 10 degrees. At an elevation angle above 5 degrees the NPS SATOPS signal was notably reduced, which in turn increased the C/I. Figure 24 shows the spectrum plot of this scenario with the NPS antenna at an elevation of 7 degrees.

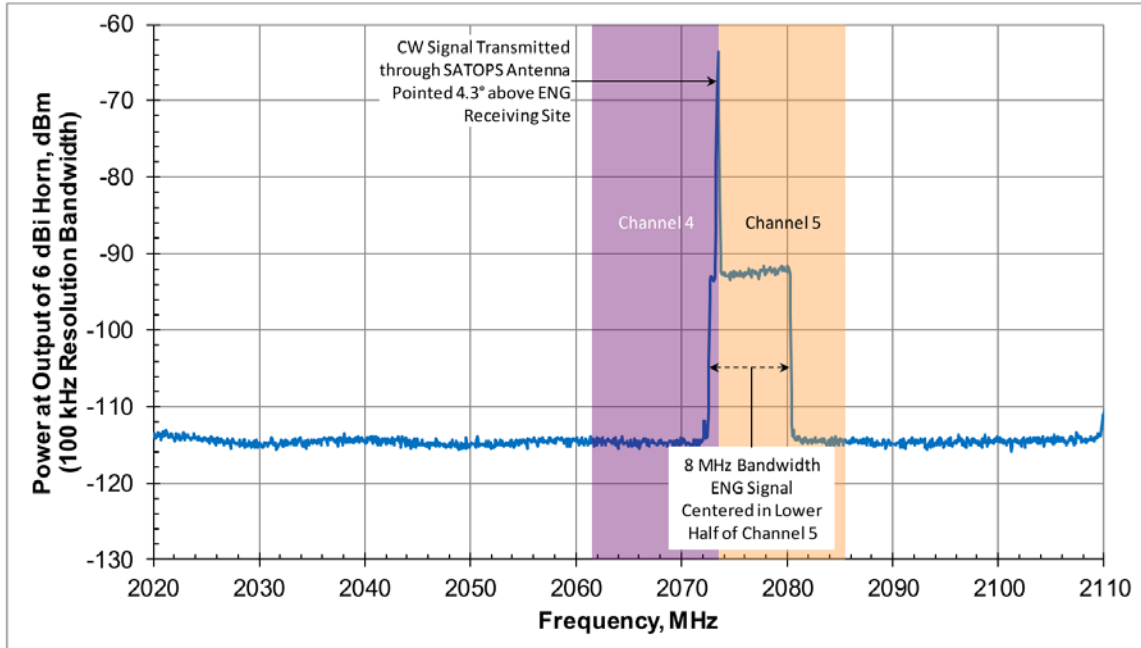

Figure 24. Signals Monitored during Cursory on-Tune RFI Measurements. Source [25].

11. Measurement Procedures

This procedure delineates the overall flow of the RFI testing [25]. From the Mt. Toro equipment room, the test director managed and directed operations based on these steps, and monitored the effects that our operations had on the ENG link.

1. Received Peak Signal level from ENG Van: Prior to the start of the testing involving the ENG van, the received signal from the van was peaked via adjustments to the antenna pointing of the ENG.
2. Establish Baseline ENG Configuration: Prior to each test, the ENG link was established in the absence of SATOPS uplink signals. ENG link integrity on both channels 4 and 5 was recorded via the NuComm receiver GUI and the desired signal was captured and recorded via the measurement collection suite as shown in Figures 18 and 19.

3. Orient SATOPS Terminal: The SATOPS uplink terminal was pointed to the appropriate azimuth and elevation (all tests conducted at 106 degrees).
4. Verify SATOPS Parameters: Verification of the intended power, frequency, bandwidth, and SATOPS antenna pointing for the particular test case was confirmed.
5. Transmit SATOPS Signal: With the ENG links established and the SATOPS terminal at the appropriate pointing angle, the SATOPS uplink signal was turned on.
6. Record Data: ENG signal metrics were recorded for both links, visual confirmation of the video link display status was noted, and the combined ENG and SATOPS spectrum signature was recorded via the collection suite.
7. Cease SATOPS Signal: at the conclusion of each test, the SATOPS signal was removed and the ENG link monitored to ensure it returned to its baseline state—confirming that any effects observed were a direct result of the introduction of the SATOPS signal.
8. Test Pre-acquisition Uplink: For cases involving ENG link in the pre-acquisition phase SATOPS uplink initiation, was done prior to the establishment of the ENG link, forcing the receiver to acquire in the presence of the SATOPS signal

D. TESTING RESULTS

1. SATOPS Antenna Characterization

As previously mentioned characterizing the NPS 3-meter SATOPS dish was an important part of completing the ENG RFI testing. Without an accurate measurement of the transmitted beam, the analysis of the interference on the

ENG operations would have been almost impossible to appreciably analyze. The antenna characterization which resulted in the boresight coupling angle was noted at angles of 106-degrees' azimuth and 2.7-degrees elevation. To fully capture the antenna beam, the azimuth analysis was conducted over a full 360-degree sweep, and the elevation was captured over a vertical sweep of 0 to 90 degrees. To create Figure 26, the data was mirrored for each set of data, and Table 5 lists antenna gains for various angles listed.

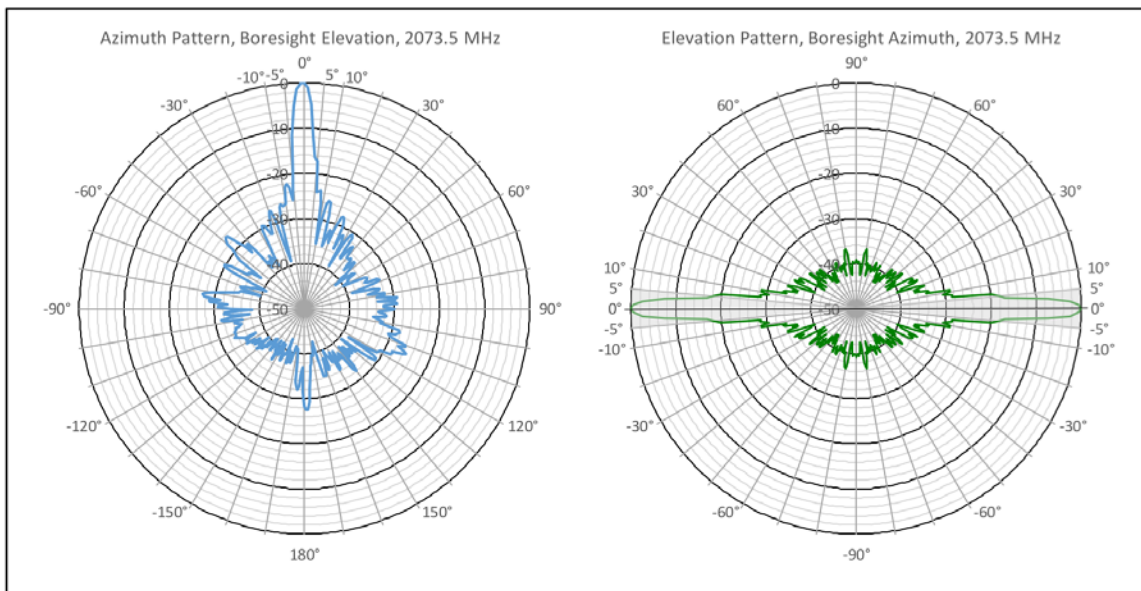

Figure 25. NPS 3-Meter Beam Pattern Characterization. Source [25].

Table 5. NPS 3-Meter SATOPS Antenna Gains. Source [25].

NPS SATOPS Antenna Elevation Angle		NPS SATOPS Antenna Gain	
Absolute	Relative to Mt Toro	Relative, dB	Absolute, dBi
2.7°	0°	0	33*
5°	2.3°	-4.7	28.3
7.7°	5°	-18.1**	14.9**
10°	7.3°	-33.7	-0.7

*This is the equipment specified mainbeam antenna gain. This value appears to be reasonably accurate, given that signal levels received through the spectrum measurement equipment were within less than 2 dB of expected levels, based on specified antenna gains and free space propagation path loss.

**Values interpolated between measured points.

2. RFI Measurements

Table 6 contains the summary results for the ENG RFI tests utilizing the five different bandwidths that were transmitted from the NPS station. As noted those bandwidths were assigned test numbers and those are annotated in the first column on the left. The assigned bandwidths are:

1. 1 MHz
2. 2 MHz
3. 3 MHz
4. 4 MHz
5. 5 MHz

Table 6. RFI Test Results. Source [25].

SATOPS Transmitter		ENG Receiver Tuned to Ch 5 (Wharf Transmitter)				ENG Receiver Tuned to Ch 4 (Van Transmitter)				Note
BW, MHz	When Introduced	RCL, dBm	Quality, %	MER, dB	BER	RCL, dBm	Quality, %	MER, dB	BER	
OFF	n/a	-58	99	26	0	-55	99	25	0	SATOPS OFF
1	Post-Acq	-58	80	18	4.50E-06	-56	97	17	0	
1	Pre-Acq	-61	73	11	5.00E-04	-57	80	13	1.00E-05	
2	Post-Acq	-54	73	13	4.50E-03	-55	83	16	2.50E-05	
2	Pre-Acq	-54	85	19	4.00E-05	-56	76	13	5.50E-04	
3	Post-Acq	-50	83	19	2.00E-03	-53	74	14	1.50E-03	
3	Pre-Acq	-50	80	19	2.00E-03	-53	81	19	1.00E-03	
4	Post-Acq	-47	67	19	6.50E-03	-49	77	16	5.00E-03	
4	Pre-Acq	-47	70	21	6.00E-03	-49	77	16	5.00E-03	
5	Post-Acq	-46	60	17	1.00E-03	-48	59	12	8.50E-03	
5	Pre-Acq	-46	60	18	1.00E-03	-48	52	13	1.00E-03	
1	Post-Acq	-58	75	11	8.50E-04	-56	97	16	0	repeat
1	Pre-Acq	-61	86	13	1.50E-05	-57	78	12	3.00E-04	repeat
2	Post-Acq	-54	77	15	2.00E-03	-55	86	18	4.50E-06	repeat
2	Pre-Acq	-54	85	17	4.00E-04	-56	83	16	6.00E-05	repeat
3	Post-Acq	-50	84	21	2.00E-03	-53	74	14	1.50E-03	repeat
3	Pre-Acq	-50	83	20	2.00E-03	-53	81	19	1.00E-03	repeat
1	Post-Acq	-60	99	21	0	-50	99	25	0	10° EI*
1	Pre-Acq	-59	99	25	0	-55	99	25	0	10° EI*

*These results were obtained with the SATOPS antenna pointed at a 10° elevation angle. The SATOPS antenna was pointed at a 5° elevation angle for all other RFI tests.

Further annotated in the far left column are two scenarios in which the NPS terminal transmitted signal was introduced to the ENG signal:

- Post-Acquiring the ENG signal: ENG signal link established with the KION-TV, Mt. Toro central receive site, followed by the introduction of the NPS terminal transmitted signal.
- Pre-Acquiring the ENG signal: NPS terminal transmission was initiated first, followed by the introduction of the ENG signal to attempt and establish a link.

Continuing right from the first column are the results on each of the two ENG channels that were tested (Channel 5, the fixed wharf, then Channel 4, the mobile van), and the different recorded metrics for each channel. The last column was used to take notes. Observations include:

- Tests 1, 2, and 3 were repeated.
- The test completed at the bottom was conducted at 10-degrees elevation instead of the otherwise conducted 5 degrees.

Pictured in Figure 22 was the image of a live feed video being streamed to the Mt. Toro central receive site, which provided an indication of the picture quality as it was being affected by the SATOPS transmission. This was observed throughout the testing. Through every test there was no distortion noted in the live feed except when the test team proceeded to the pre-acquisition 5 MHz SATOPS broadcast during the ENG broadcast on Channel 4 from the van transmitter. The quality of the link fell to 52% which was the first instance of pixilation/distortion. Link quality is a value calculated automatically by the Nucomm Newcaster CR7 receiver unit, and is determined from various parameters such as bit error ratio (BER) and the ratio of signal-plus-noise-distortion to noise-plus-distortion (SINAD). A value of 100% represents a perfect feed, without detectable errors. A value of 75% is considered an acceptable link quality that is useable for commercial ENG even with some errors. The RFI testing affirmed a value below 60% was unacceptable due to the potential for a loss of the link, and useable links were not acquired below a link quality of 50%.

To produce results that can be used to easily follow trends in the test studies, Figures 26 through 29 present the recorded data from the various ENG RFI tests in bar graph form. SATOPS bandwidth operations are color-coded with the repeat tests discussed previously, averaged in with the results from the initial test data gathered.

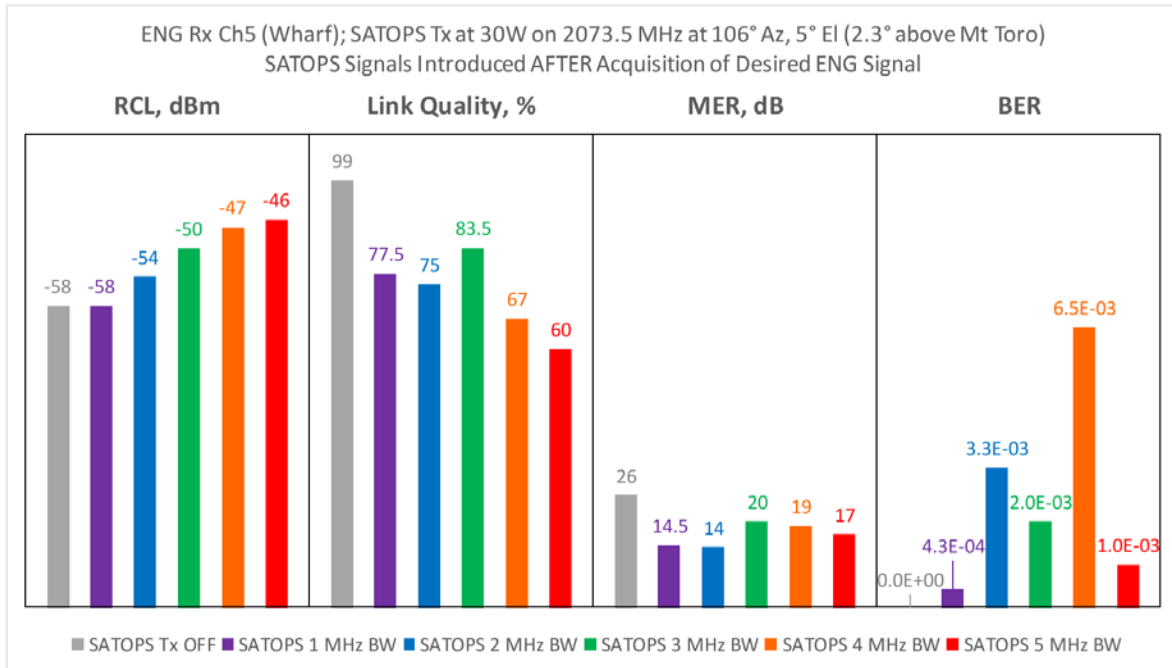

Figure 26. Post-Acquisition RFI Test Results, ENG Channel 5 (Wharf Tx). Source [25].

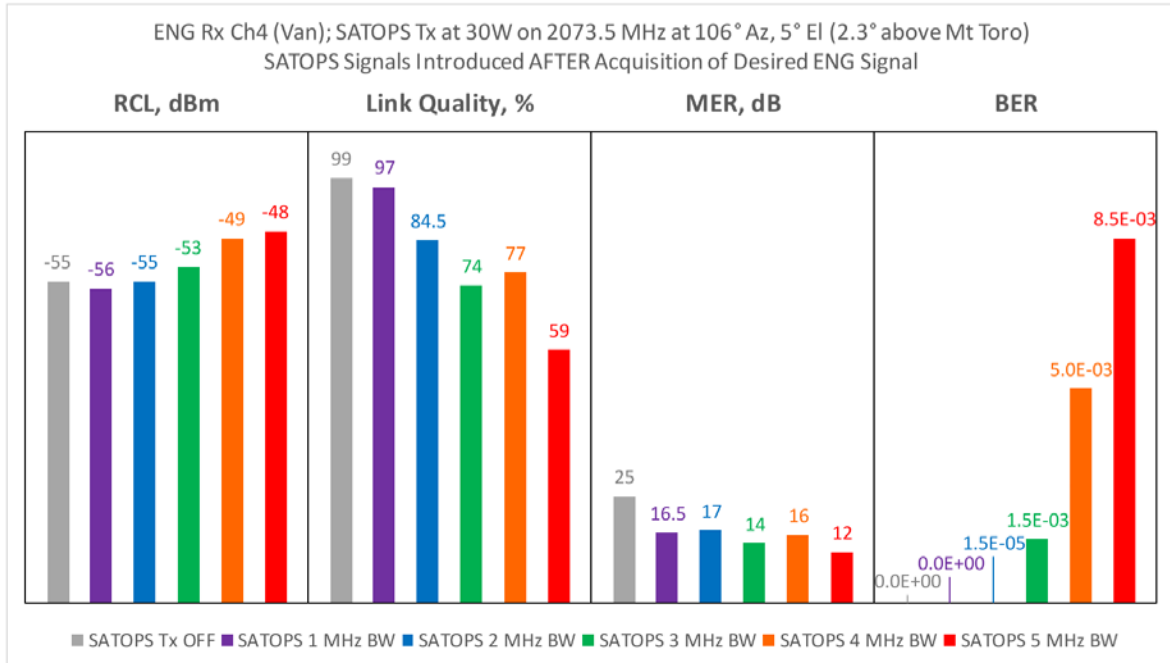

Figure 27. Post-Acquisition RFI Test Results, ENG Channel 4 (Van Tx).
Source [25].

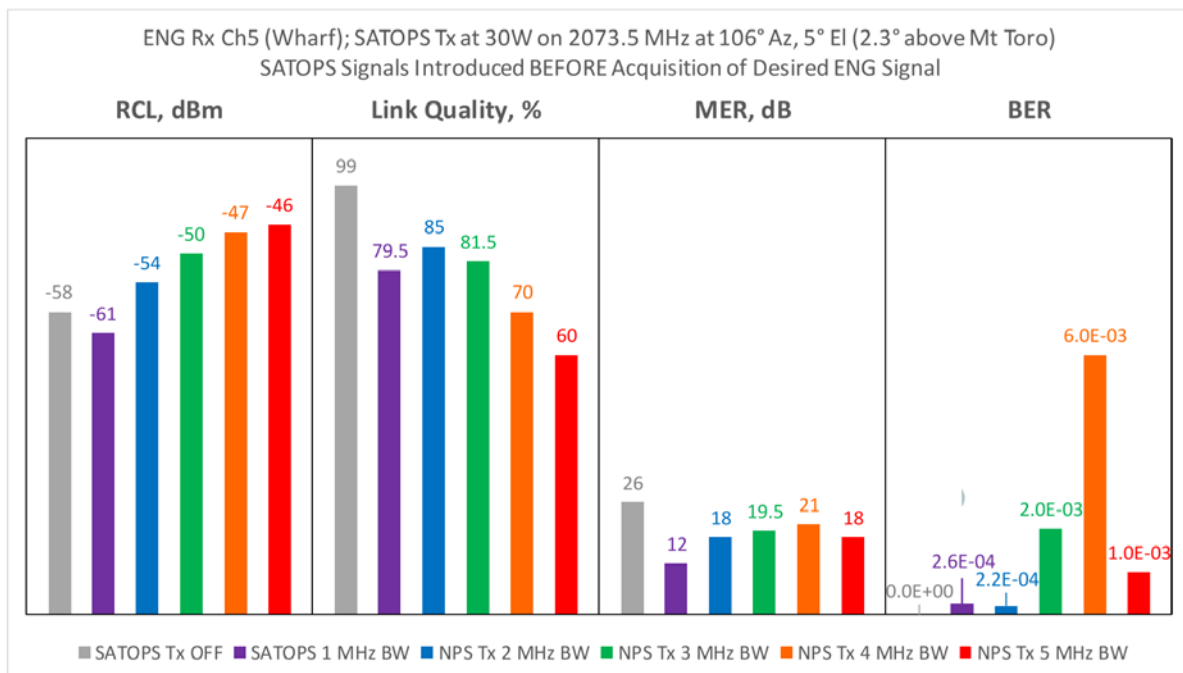

Figure 28. Pre-Acquisition RFI Test Results, ENG Channel 5 (Wharf Tx).
Source [25].

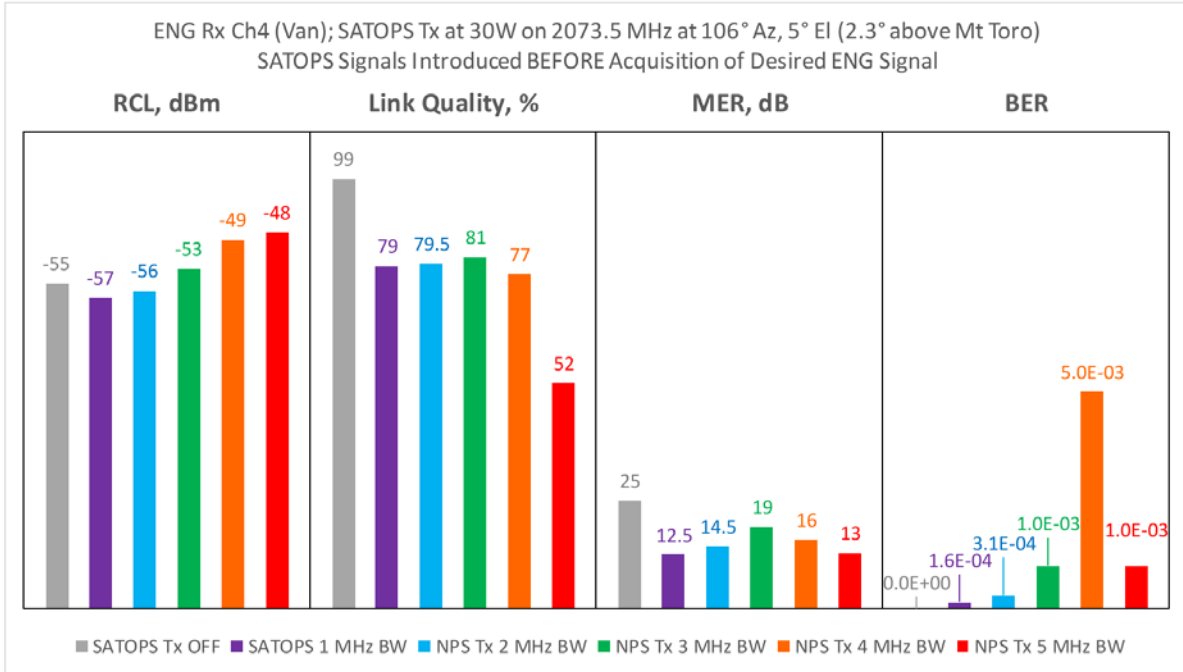

Figure 29. Pre-Acquisition RFI Test Results, ENG Channel 4 (Van Tx).
Source [25].

For the data that is displayed in Figures 26 through 29 the trend in each category is noticeable for each of the applied SATOPS bandwidths from the NPS terminal. Noted for each category:

- Received Carrier Level (RCL): In both Channel 4 and Channel 5 post-acquisition tests the received carrier level increases above the baseline noticeably in when the SATOPS bandwidth increases after the 2 MHz SATOPS bandwidth. In the pre-acquisition tests it is a similar trend but the Channel 5 ENG transmission is slower to be topped by the SATOPS transmissions. Channel 4 had a stronger desired signal than Channel 5 by about 3 dB. This increase in power is what caused the difference in results in the two channels because Channel 4 required a wider undesired signal bandwidth.
- Link Quality: As the SATOPS transmission increases in bandwidth the link quality noticeably decreases non-linearly, with slight variations in the results.

- Modulation Error Ratio (MER): With every test, there was a noticeable overall decrease in the MER. This decrease was not consistent by any measure.
- Bit-Error Rate (BER): The BER increased overall with every test that was conducted with the 4 MHz SATOPS transmission exhibiting the worst effects on the BER.

Figures 30 through 33 are set up in a manner to highlight the differences between the Channel 5 post-acquisition, Channel 4 post-acquisition, Channel 5 pre-acquisition, and Channel 4 pre-acquisition figures with the SATOPS transmission off, then with each SATOPS bandwidth being present. The results from the repeating of tests 1, 2, and 3 were averaged together with the first test results.

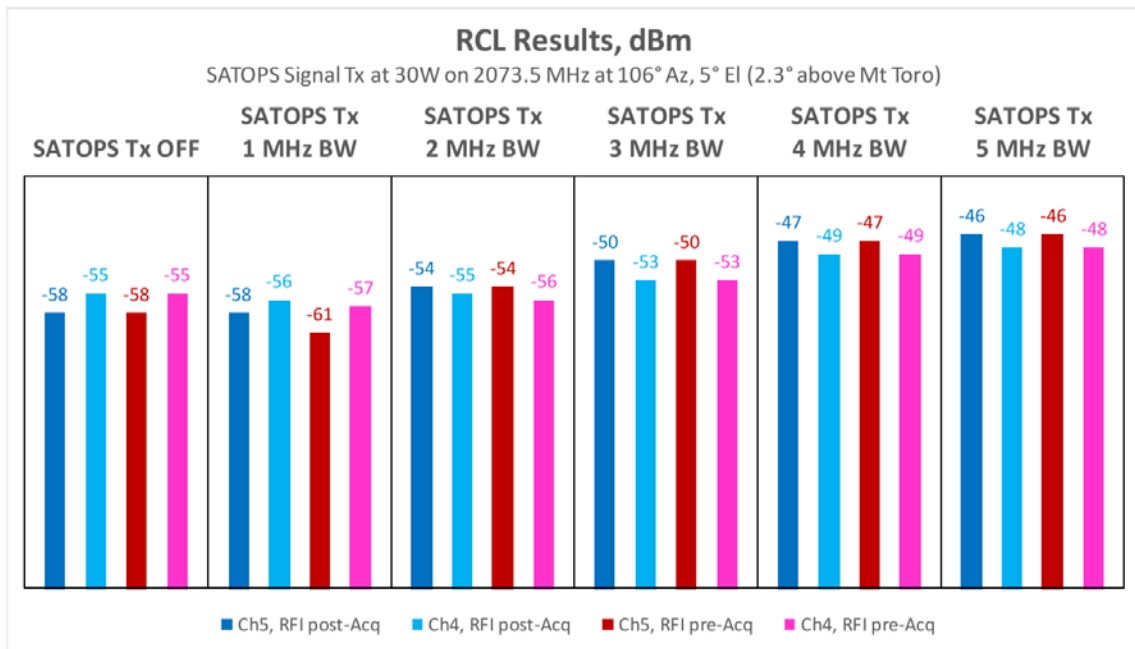

Figure 30. RCL Comparison. Source [25].

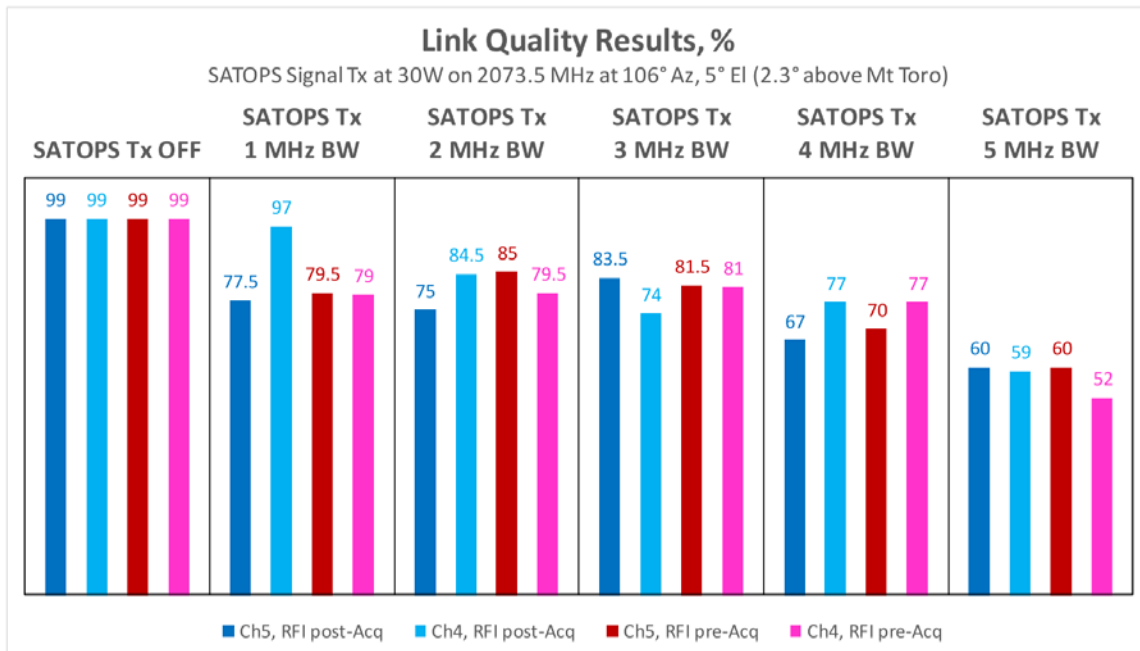

Figure 31. Link Quality Comparison. Source [25].

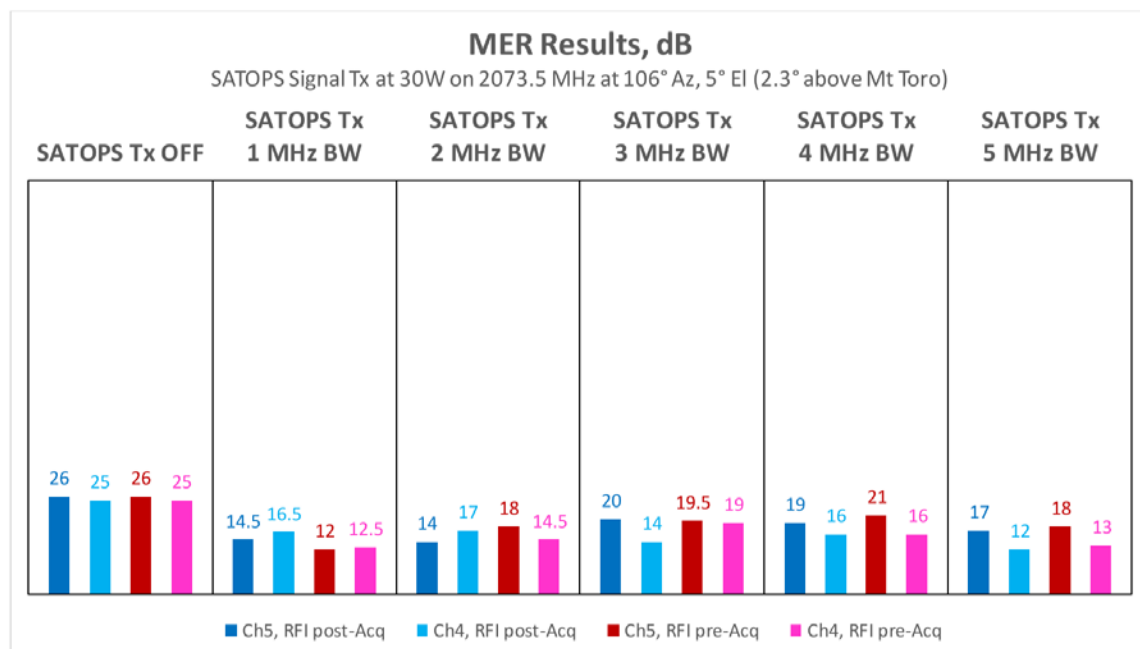

Figure 32. MER Comparison. Source [25].

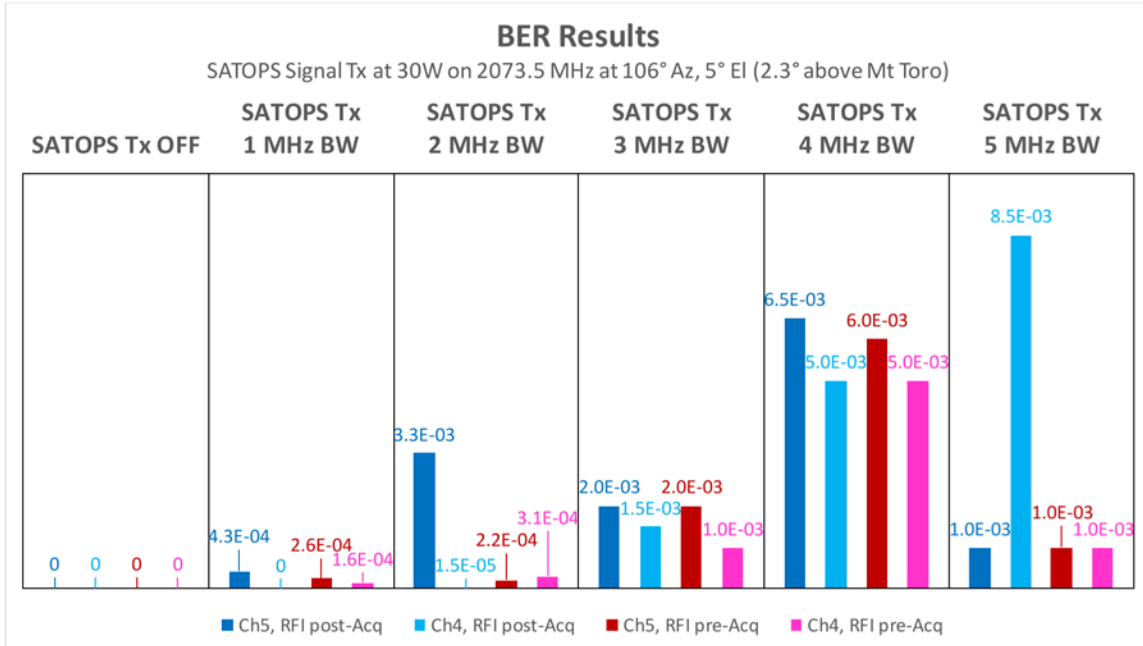

Figure 33. BER Comparison [25].

The results from Figures 31 through 33 demonstrate mostly expected results. The timing of the introduction of the SATOPS transmission did not significantly alter the signal measurements. Both pre and post-acquisition values were close enough to not be an appreciable factor. Channel 4 was a stronger channel; as explained previously, this resulted in less impact from the SATOPS transmissions.

There was one exception in the trends and analysis of the tests. In Figure 30 the results were unexpectedly reversed in the sense that introducing the SATOPS transmission increased the RCL instead of lowering it like every other test demonstrated. This can be explained as follows:

In the absence of SATOPS signals and in the presence of the 1 MHz bandwidth SATOPS signal, the RCL was weaker when the receiver was tuned to the weaker Channel 5 ENG signal as compared to when it was tuned to the stronger Channel 4 signal, as expected. However, in the presence of the wider bandwidth SATOPS signals, RCL was consistently stronger when the receiver was tuned to the weaker Channel 5 signal. This can be explained by the fact that the SATOPS signal is located above Channel 4 and

below Channel 5, and the possibility that the spectral roll-off of ENG receiver filter, the SATOPS signal, or both could be somewhat asymmetric about their respective nominal center frequencies. [25]

As pointed out in the previous data, tests 1, 2, and 3 were unique in the fact that they had the opportunity to be conducted twice. Figures 34 through 36 lay out each of these tests next to one another with the exception of the RCL data because the results duplicated the initial tests. From left to right these figures lay out the tests 1 through 3 completed on Channel 4, then tests 1 through 3 completed on Channel 5.

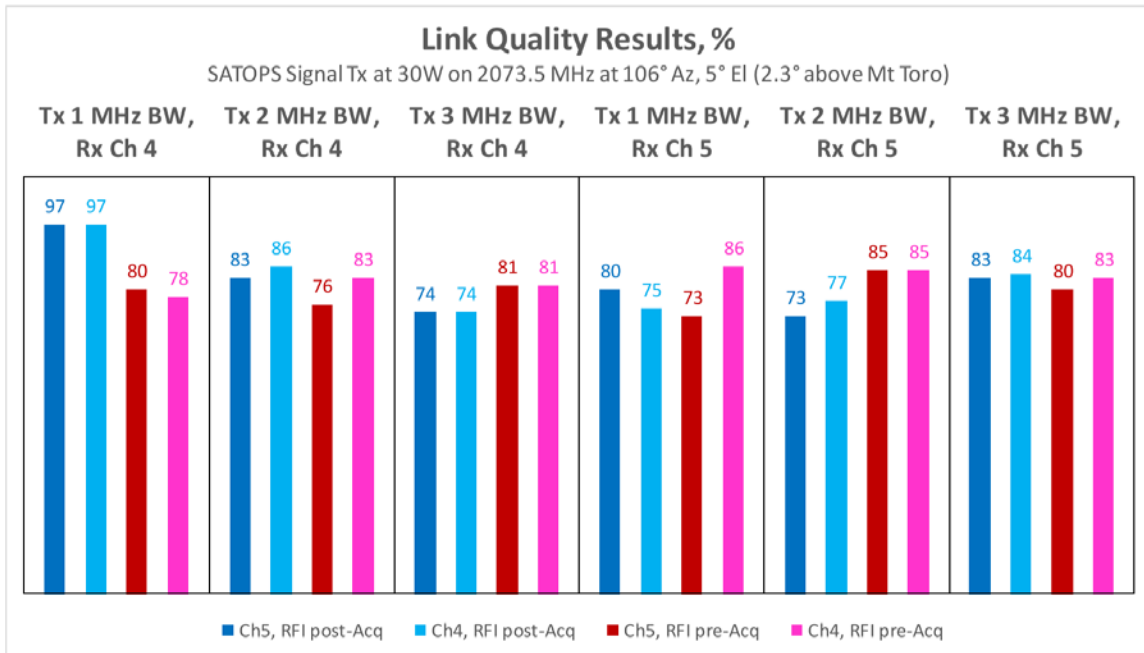

Figure 34. Repeated Tests Link Quality. Source [25].

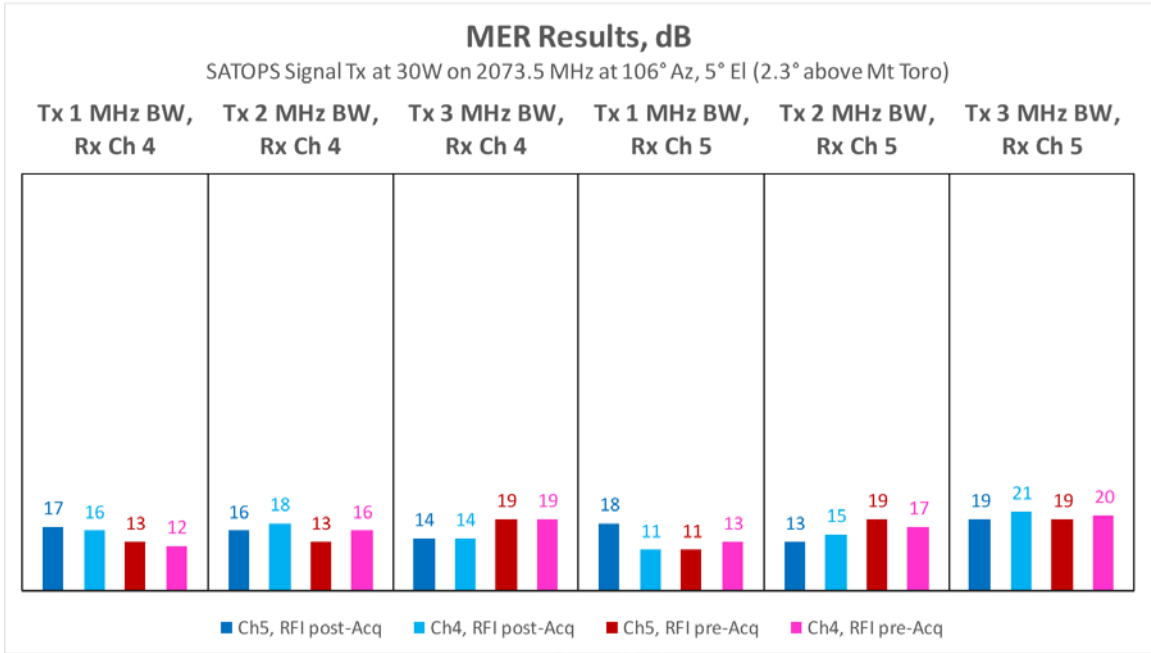

Figure 35. Repeated Test MER. Source [25].

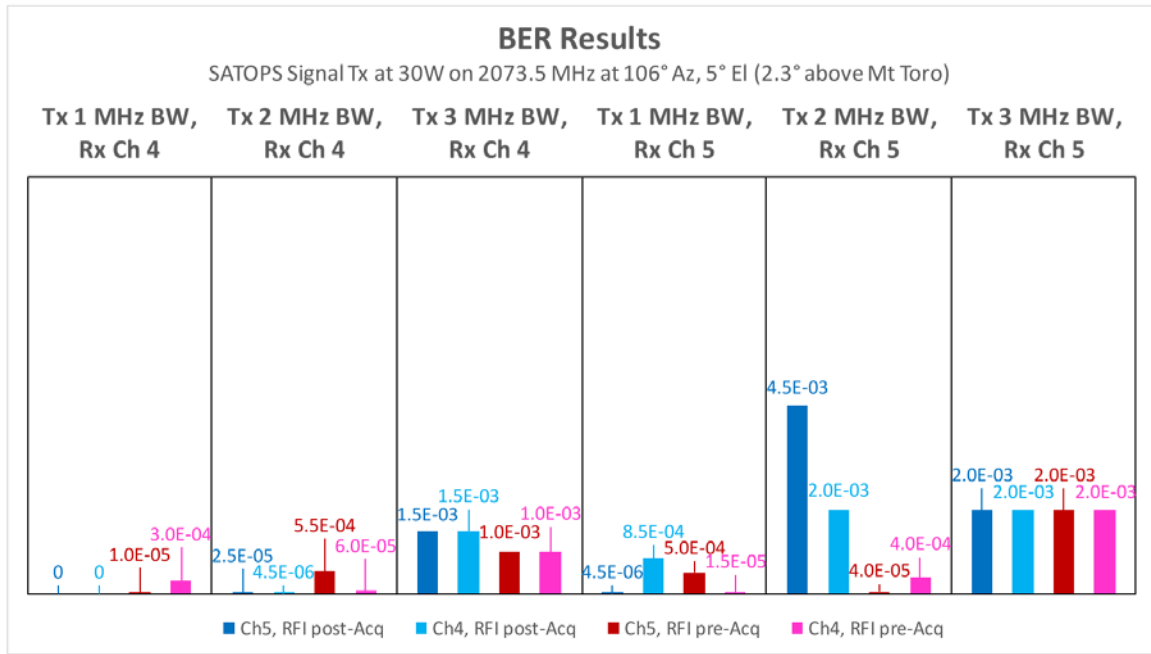

Figure 36. Repeated Tests BER. Source [25].

In Chapter III.C.10 an accidental condition being introduced to the scenario was discussed. Table 7 presents the data that was recorded and observations made during the analysis. The ENG transmission being tuned to a lower-half, band-split configuration with an 8 MHz bandwidth, was not in the procedure and was not anticipated to provide data. Looking at the data one can derive that:

- Complete loss of ENG signal occurred at SATOPS elevation of 5 and 6 degrees.
- The C/I for this condition to occur was at -17dB or less.
- Above SATOPS elevation of 7 degrees or greater the link quality was at 75% or greater. The C/I was -10 dB or greater for the same conditions.

Table 7. Cursory On-Tune RFI Measurements. Source [25].

SATOPS Signal				When Signal was Introduced	ENG Receiver Observations	
Antenna					Link quality	Comment
EI, Absolute	EI, Relative to Mt Toro	Measured Power, dBm ¹	C/I, dB ²			
N/A	N/A	N/A	N/A	Post-Acq	99%	SATOPS Signal OFF
5°	2.3°	-48	-24	Pre-Acq	-	Lost lock; recovered within 1-2 seconds of RFI removal
10°	7.3°	-78	6	Post-Acq	91%	No Pic effect 5 dB increase in noise
8°	5.3°	-62	-10	Post-Acq	78%	No noticeable effect to picture quality
8°	5.3°	-62	-10	Post-Acq	78%	Reacquired no issue
6°	3.3°	-55	-17	Pre-Acq	30%	Lost lock
7°	4.3°	-64	-8	Post-Acq	80%	No noticeable effect to picture quality
7°	4.3°	-64	-8	Post-Acq	80%	Reacquired no issues

¹Power at measurement system horn antenna output port.
²Based on Channel 5 signal power of -72 dBm at the measurement system horn antenna output port.

THIS PAGE INTENTIONALLY LEFT BLANK

III. CONCLUSIONS AND FUTURE OPERATIONS

A. RFI TEST RESULTS ANALYSIS

The testing conducted with KION-TV and the test engineers concluded with favorable results. These results indicate that EM spectrum sharing is a viable solution for the task of utilizing USB to conduct TT&C operations in the same geographical region that ENG operations are taking place. Spectrum conflict will continue to be an issue for proper management and licensing, but easing the strain on juggling the EM bandwidths that the FCC and NTIA license by creating a program of bandwidth sharing could become one of the most cost-effective and least manpower-intensive solutions.

The ENG link quality is considered acceptable when it is above 75%. Although there were no visible signs of ENG signal degradation with a link quality of 60%, this is an unacceptable link quality according to the ENG engineer, as it is too close to being unreliable. When the quality of the link dropped below 60%, the ENG transmission would show obvious pixilation, and occasionally result in loss of the link. Below a 60% link quality value, the link itself was deemed unreliable. Therefore, 75% link quality, as determined by the KION engineer's equipment, should be established as a minimum performance threshold. At below 50% the link quality was so low that the receiver could not lock to the transmitted signal and no usable video could be received. Once this occurred, termination of the SATOPS transmission resulted in the immediate recovery of the ENG link.

The NPS 3-meter SATOPS ground terminal was used to determine the effects USB transmissions would have on local ENG operations. The NPS 3-meter terminal beam characterization in Tables 5 and 7 show the level of interference caused by the SATOPS on the ENG reception as a function of dish elevation angle, both absolute and relative, to the receiver. Because pointing the SATOPS antenna directly at the Mt. Toro receiver (0-degrees relative or 2.7-

degrees absolute antenna elevation) is not acceptable and a 5-degree relative antenna elevation resulted in a link quality of greater than 75%, we can conclude that limiting the elevation angle of the SATOPS transmitter should be adequate to prevent unacceptable interference with ENG transmissions. Additionally, adding a couple more degrees of minimum elevation angle would further reduce possible interference with ENG operations. This would set the SATOPS minimum elevation angle for transmissions to about 7-degrees relative (10-degrees absolute) and should guarantee that the ENG link quality does not ever go below 75% due to SATOPS. While this minimum elevation angle should work for NPS SATOPS in Monterey, such restrictions may also be useful and should be investigated for other locations, especially given that most SATOPS do not typically start until satellites have achieved a local elevation angle of at least 10-degrees absolute. Additionally, many SATOPS would gladly restrict their minimum transmission elevation angles even more to ensure non-interference with local ENG in exchange for permission to conduct SATOPS at all.

Although the most important result to come of this RFI testing may be that SATOPS transmissions from the NPS terminal above a 7-degree relative (10-degree absolute) elevation can coexist with the ENG operations, it is also important to note that , with proper planning and coordination with ENG operators, placing SATOPS signals in between the 12 MHz ENG channels (channel interleaving) while operating ENG operations at a centralized 8 MHz bandwidth also eliminates any degradation of ENG link quality. This kind of coordination in operations presents a valuable opportunity for the future of spectrum sharing and warrants more discussion. Because ENG operations has priority for the use of the spectrum, finding ways for SATOPS to operate on a non-interference basis with ENG transmissions is the key.

B. FUTURE TESTING

The key to further implementing the concept is further investigation into more constrained environments, “such as azimuth transmission limits as well as elevation limits, different modulations, more error correction schemes, different antenna combinations, different SATOPS waveforms, a variety of SATOPS antennas, and the capability to conduct more of the same testing” [25]. This all requires time and money, which are the most constrained resources. ENG engineers have to be coordinated with and longer, more in-depth studies may need to involve some means of compensation for the time ENG engineers would have to dedicate to study operations to ensure SATOPS does not degrade the signals for which they are responsible.

In order to build on the results of the RFI testing conducted at NPS, the existing MC3 network of ground stations can be utilized to conduct similar testing in the varying geographic and EM environments around the U.S. The results of the testing procedures regarding USB RFI testing are key to improving the MC3 ground networks’ capabilities and the lessons learned in Monterey may potentially set a constructive and reproducible precedent for SATOPS around the U.S. for government SmallSat stations. Such testing in conjunction with previous and future efforts should be a priority so that an effective DoD wide Concept of Operations can be developed for SATOPS cooperation with ENG.

THIS PAGE INTENTIONALLY LEFT BLANK

LIST OF REFERENCES

- [1] J. S. Belrose, "A radioscience's reaction to Marconi's first transatlantic wireless experiment-revisited," in *IEEE Ant. & Prop. Soc. Int. Symp.*, 2001. [Online]. Available: http://www.radiocom.net/Fessenden/Marconi_Reprint.pdf
- [2] J. H. Morecroft, "What everyone should know about radio history," *Radio Broadcast*, vol. 1, no. 3, pp. 199, July 1922. [Online]. Available: <https://search.proquest.com/docview/1298289565>
- [3] M. Tullai, "Wireless Ship Act of 1910," *Encyclopedia of the First Amendment*, vol. 2, J. Vile, D.L. Hudson, and D. Schultz, Eds. Washington, DC: SAGE Publications Ltd., 2009, pp 1179-1180.
- [4] B. Kovarik, "Radio and the Titanic," *Revolutions in Communications*. Accessed November 13, 2017. [Online]. Available: <http://www.environmentalhistory.org/revcomm/features/radio-and-the-titanic/>
- [5] Cliff, "Marconi Room," flickr.com, February 12, 2009. [Online]. Available: <https://www.flickr.com/photos/nostri-imago/3278643769/in/photostream/>
- [6] S. Morrison, "Radio Act of 1912," *Encyclopedia of the First Amendment*, vol. 2, J. Vile, D.L. Hudson, and D. Schultz, Eds. Washington, DC: CQ Press, 2009, pp 906-907.
- [7] M. Goodman, "The Radio Act of 1927 as a product of progressivism," Mississippi State University. [Online]. Available: <https://www.scripps.ohiou.edu/mediahistory/mhmjour2-2.htm>
- [8] S. Morrison, "Radio Act of 1927," *Encyclopedia of the First Amendment*, vol. 2, J. Vile, D.L. Hudson, and D. Schultz, Eds. Washington, DC: CQ Press, 2009, pp 907.
- [9] B. Caterina, "Communications Act of 1934," *Encyclopedia of the First Amendment*, vol. 2, J. Vile, D.L. Hudson, and D. Schultz, Eds. Washington, DC: CQ Press, 2009, pp 320.
- [10] "Radio Spectrum Allocation," Federal Communications Commission. Accessed October 5, 2017. [Online]. Available: <https://www.fcc.gov/engineering-technology/policy-and-rules-division/general/radio-spectrum-allocation>

- [11] J. Poushter, "Smartphone ownership and Internet usage continues to climb in emerging economies," Pew Research Center, February 22, 2016. [Online]. Available: <http://www.pewglobal.org/2016/02/22/smartphone-ownership-and-internet-usage-continues-to-climb-in-emerging-economies/>
- [12] Statista, "Number of smartphone users in the United States from 2010 to 2022." [Online]. Available: <https://www.statista.com/statistics/201182/forecast-of-smartphone-users-in-the-us/>
- [13] M. Swartwout, "CubeSats and mission success: A look at the numbers," presented at 2016 CubeSat Dev. Wkshop, St. Louis Univ, St. Louis, MO, April 20, 2016. [Online]. Available: http://mstl.atl.calpoly.edu/~bklofas/Presentations/DevelopersWorkshop2016/1_MichaelSwartwout.pdf
- [14] 11th Annual Cisco Mobile Visual Networking Index (VNI) Forecast Projects 7-Fold Increase in Global Mobile Data Traffic from 2016–2021. [Online]. Available: <https://www.cisco.com/c/en/us/solutions/collateral/service-provider/visual-networking-index-vni/mobile-white-paper-c11-520862.html>
- [15] "About Auctions," Federal Communications Commission. Accessed October 20, 2017. [Online]. Available: http://wireless.fcc.gov/auctions/default.htm?job=about_auctions
- [16] "Auctions Summary," Federal Communications Commission. Accessed October 20, 2017. 2015. [Online]. Available: http://wireless.fcc.gov/auctions/default.htm?job=auctions_all
- [17] J. E. Bryson and L. E. Strickling, "An assessment of the viability of accommodating wireless broadband in the 1755 – 1850 MHz band," Department of Commerce, March. 2012.
- [18] M. J. Marcus, "New approaches to private sector sharing of federal government spectrum," *New America Foundation*, June 2009.
- [19] Federal Communications Commission, "Innovation in the broadcast television bands: allocations, channel sharing and improvements to VHF," Washington, DC, USA, Rep. FCC 12-45, April 27, 2012. [Online]. Available: https://apps.fcc.gov/edocs_public/attachmatch/FCC-12-45A1.pdf
- [20] A. Popkin, R. Knipp, E. Hernandez. "Overview of the KLCS/KJLA channel sharing pilot," Los Angeles, CA, USA, March, 28. 2014. [Online]. Available: <https://www.ctia.org/docs/default-source/fcc-filings/technical-report-of-the-klcs-kjla-channel-sharing-pilot.pdf>

- [21] L. Wood, "Global small satellite market 2017–2026 - over 6,200 smallsats are expected to be launched over the next ten years," NASDAQ OMX's News Release Distribution Channel, 2017. [Online]. Available: <https://search.proquest.com/docview/1927744346>

- [22] "FCC online table of frequency allocations," Federal Communications Commission Office of Engineering and Technology Policy and Rules Division, August 25, 2017. [Online]. Available: <https://transition.fcc.gov/oet/spectrum/table/fcctable.pdf>

- [23] S. M. Alcaide, "Mobile cubesat command and control (MC3) 3-meter dish calibration and capabilities," M.S. thesis, SSAG, NPS, Monterey, CA, USA, 2014.

- [24] G. Minelli, D. Rigmaiden, J. Newman, J. Horning, "MC3 ground station network," presented at Naval Postgraduate School, NPS, Monterey, CA, USA, 2017.

- [25] D. Alianti, J. Browning and M. Dion, "SATOPS BAS/ENG radio frequency interference testing," unpublished.

THIS PAGE INTENTIONALLY LEFT BLANK

INITIAL DISTRIBUTION LIST

1. Defense Technical Information Center
Ft. Belvoir, Virginia
2. Dudley Knox Library
Naval Postgraduate School
Monterey, California