

2-10-98

Vol. 63

No. 27

Tuesday
February 10, 1998

Federal Register

United States
Government
Printing Office

SUPERINTENDENT
OF DOCUMENTS
Washington, DC 20402

OFFICIAL BUSINESS
Penalty for private use, \$300

PERIODICALS

Postage and Fees Paid
U.S. Government Printing Office
(ISSN 0097-6326)

*****3-DIGIT 481
A FR UMI 346U DEC 98 R
UMI
SERIALS ACQUISITIONS
PO BOX 1346
ANN ARBOR MI 48106

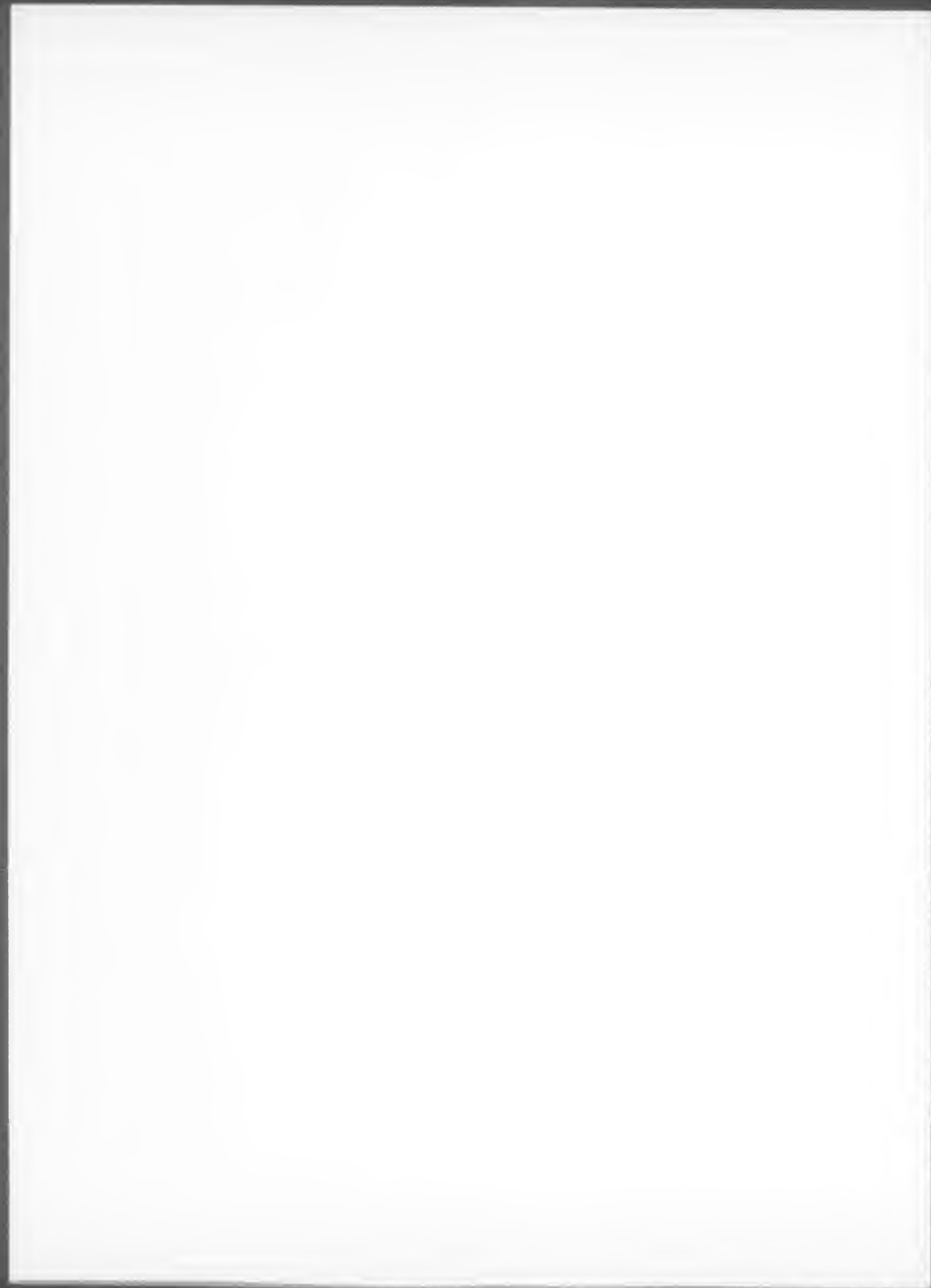

2-10-98
Vol. 63 No. 27
Pages 6627-6838

Tuesday
February 10, 1998

Federal Register

Briefings on how to use the Federal Register

For information on briefings in Washington, DC, and Atlanta, GA see announcement on the inside cover of this issue.

**Now Available Online via
*GPO Access***

Free online access to the official editions of the *Federal Register*, the *Code of Federal Regulations* and other Federal Register publications is available on *GPO Access*, a service of the U.S. Government Printing Office at:

<http://www.access.gpo.gov/nara/index.html>

For additional information on *GPO Access* products, services and access methods, see page II or contact the *GPO Access* User Support Team via:

- ★ Phone: toll-free: 1-888-293-6498
- ★ Email: gpoaccess@gpo.gov



FEDERAL REGISTER Published daily, Monday through Friday, (not published on Saturdays, Sundays, or on official holidays), by the Office of the Federal Register, National Archives and Records Administration, Washington, DC 20408, under the Federal Register Act (49 Stat. 500, as amended; 44 U.S.C. Ch. 15) and the regulations of the Administrative Committee of the Federal Register (1 CFR Ch. I). Distribution is made only by the Superintendent of Documents, U.S. Government Printing Office, Washington, DC 20402.

The **Federal Register** provides a uniform system for making available to the public regulations and legal notices issued by Federal agencies. These include Presidential proclamations and Executive Orders and Federal agency documents having general applicability and legal effect, documents required to be published by act of Congress and other Federal agency documents of public interest. Documents are on file for public inspection in the Office of the Federal Register the day before they are published, unless earlier filing is requested by the issuing agency.

The seal of the National Archives and Records Administration authenticates this issue of the **Federal Register** as the official serial publication established under the Federal Register Act. 44 U.S.C. 1507 provides that the contents of the **Federal Register** shall be judicially noticed.

The **Federal Register** is published in paper, 24x microfiche and as an online database through *GPO Access*, a service of the U.S. Government Printing Office. The online edition of the **Federal Register** on *GPO Access* is issued under the authority of the Administrative Committee of the Federal Register as the official legal equivalent of the paper and microfiche editions. The online database is updated by 6 a.m. each day the **Federal Register** is published. The database includes both text and graphics from Volume 59, Number 1 (January 2, 1994) forward. Free public access is available on a Wide Area Information Server (WAIS) through the Internet and via asynchronous dial-in. Internet users can access the database by using the World Wide Web; the Superintendent of Documents home page address is http://www.access.gpo.gov/su_docs/, by using local WAIS client software, or by telnet to [swais.access.gpo.gov](telnet://swais.access.gpo.gov), then login as guest, (no password required). Dial-in users should use communications software and modem to call (202) 512-1661; type swais, then login as guest (no password required). For general information about *GPO Access*, contact the *GPO Access* User Support Team by sending Internet e-mail to gpoaccess@gpo.gov; by faxing to (202) 512-1262; or by calling toll free 1-888-293-6498 or (202) 512-1530 between 7 a.m. and 5 p.m. Eastern time, Monday-Friday, except for Federal holidays.

The annual subscription price for the **Federal Register** paper edition is \$555, or \$607 for a combined **Federal Register**, **Federal Register Index** and **List of CFR Sections Affected (LSA)** subscription; the microfiche edition of the **Federal Register** including the **Federal Register Index** and **LSA** is \$220. Six month subscriptions are available for one-half the annual rate. The charge for individual copies in paper form is \$8.00 for each issue, or \$8.00 for each group of pages as actually bound; or \$1.50 for each issue in microfiche form. All prices include regular domestic postage and handling. International customers please add 25% for foreign handling. Remit check or money order, made payable to the Superintendent of Documents, or charge to your GPO Deposit Account, VISA, MasterCard or Discover. Mail to: New Orders, Superintendent of Documents, P.O. Box 371954, Pittsburgh, PA 15250-7954.

There are no restrictions on the republication of material appearing in the **Federal Register**.

How To Cite This Publication: Use the volume number and the page number. Example: 60 FR 12345.

SUBSCRIPTIONS AND COPIES

PUBLIC

Subscriptions:

Paper or fiche 202-512-1800
Assistance with public subscriptions 512-1806

General online information 202-512-1530; 1-888-293-6498

Single copies/back copies:

Paper or fiche 512-1800
Assistance with public single copies 512-1803

FEDERAL AGENCIES

Subscriptions:

Paper or fiche 523-5243
Assistance with Federal agency subscriptions 523-5243

FEDERAL REGISTER WORKSHOP

THE FEDERAL REGISTER: WHAT IT IS AND HOW TO USE IT

- FOR:** Any person who uses the Federal Register and Code of Federal Regulations.
- WHO:** Sponsored by the Office of the Federal Register.
- WHAT:** Free public briefings (approximately 3 hours) to present:
1. The regulatory process, with a focus on the Federal Register system and the public's role in the development regulations.
 2. The relationship between the Federal Register and Code of Federal Regulations.
 3. The important elements of typical Federal Register documents.
 4. An introduction to the finding aids of the FR/CFR system.
- WHY:** To provide the public with access to information necessary to research Federal agency regulations which directly affect them. There will be no discussion of specific agency regulations.

WASHINGTON, DC

WHEN: February 17, 1998 at 9:00 am.
WHERE: Office of the Federal Register
Conference Room
800 North Capitol Street NW.,
Washington, DC
(3 blocks north of Union Station Metro)

RESERVATIONS: 202-523-4538

ATLANTA, GA

WHEN: March 10, 1998
WHERE: Jimmy Carter Library
Theater A—Museum
441 Freedom Plaza
One Copenhill Avenue
Atlanta, GA 30307-1498

RESERVATIONS: Call the Federal Information Center
1-800-688-9889, Ext. 0



Contents

Federal Register

Vol. 63, No. 27

Tuesday, February 10, 1998

African Development Foundation

NOTICES

Meetings; Sunshine Act, 6703

Agricultural Marketing Service

PROPOSED RULES

Limes and avocados grown in Florida, 6679-6681

Agriculture Department

See Agricultural Marketing Service

See Animal and Plant Health Inspection Service

See Cooperative State Research, Education, and Extension Service

See Farm Service Agency

See Federal Crop Insurance Corporation

See Forest Service

See Risk Management Agency

See Rural Business-Cooperative Service

See Rural Housing Service

See Rural Utilities Service

NOTICES

Meetings:

Strategic Planning Task Force, 6703

Animal and Plant Health Inspection Service

NOTICES

Environmental statements; availability, etc.:

Nonregulated status determinations—

AgrEvo USA Co.; genetically engineered canola, 6703-6704

Meetings:

Animal welfare program and initiatives, 6704

Assassination Records Review Board

NOTICES

Formal determinations on records release, 6705-6720

Census Bureau

NOTICES

Agency information collection activities:

Proposed collection; comment request, 6720-6721

Centers for Disease Control and Prevention

NOTICES

Meetings:

Breast and Cervical Cancer Early Detection and Control Advisory Committee, 6761

Childhood Lead Poisoning Prevention Advisory Committee, 6761

Commerce Department

See Census Bureau

See International Trade Administration

See National Institute of Standards and Technology

See National Oceanic and Atmospheric Administration

Committee for the Implementation of Textile Agreements

NOTICES

Cotton, wool, and man-made textiles:

El Salvador, 6727-6728

Cooperative State Research, Education, and Extension Service

NOTICES

Grants and cooperative agreements; availability, etc.:

Agricultural risk management education program, 6810-6816

Defense Department

See Navy Department

NOTICES

Federal Acquisition Regulation (FAR):

Agency information collection activities—

Proposed collection; comment request, 6728

Drug Enforcement Administration

NOTICES

Applications, hearings, determinations, etc.:

Wagner, Richard S., M.D., 6771-6774

Education Department

NOTICES

Agency information collection activities:

Proposed collection; comment request, 6731-6732

Submission for OMB review; comment request, 6732

Grants and cooperative agreements; availability, etc.:

Fund for improvement of postsecondary education program, 6830-6831

Meetings:

Foreign Medical Education and Accreditation National Committee, 6732-6733

Postsecondary education:

Accrediting agencies and State approval agencies for vocational and nurse education institutions; national recognition, 6733

Employment and Training Administration

NOTICES

Agency information collection activities:

Proposed collection; comment request, 6774

Federal-State unemployment compensation program:

Unemployment insurance program letters—
Federal unemployment insurance law interpretation, 6774-6781

Energy Department

See Federal Energy Regulatory Commission

NOTICES

Atomic energy agreements; subsequent arrangements, 6733-6736

Meetings:

Environmental Management Site-Specific Advisory Board—

Nevada Test Site, 6736

Secretary of Energy Advisory Board, 6736-6737

Environmental Protection Agency

RULES

Acquisition regulations:

Information Resources Management policies; electronic access; correction, 6676-6677

Profit or fee calculations; correction, 6675-6676

Air programs; approval and promulgation; State plans for designated facilities and pollutants:
 New Mexico et al.; correction, 6664-6665

Air quality implementation plans:
 Preparation, adoption, and submittal—
 Vehicle inspection and maintenance program requirements; motorist compliance enforcement mechanisms for pre-existing programs; correction, 6645

Air quality implementation plans; approval and promulgation; various States; air quality planning purposes; designation of areas:
 Ohio et al.; correction, 6664

Air quality implementation plans; approval and promulgation; various States:
 Arizona, 6653-6659
 Michigan, 6650-6651
 Minnesota; correction, 6647-6648
 Missouri; correction, 6645-6646, 6648-6649
 Ohio; correction, 6646-6647, 6649-6650
 Texas, 6651-6653, 6659-6664
 Washington; correction, 6648

Hazardous waste:
 State underground storage tank program approvals—
 West Virginia; correction, 6667

Hazardous waste program authorizations:
 Alabama; correction, 6666-6667

Pesticides; tolerances in food, animal feeds, and raw agricultural commodities:
 Thiodicarb; correction, 6665-6666

Superfund program:
 Toxic chemical release reporting; community right-to-know—
 Hydrochloric acid; correction, 6668

Toxic substances:
 Significant new uses—
 Cyclohexanecarbonitrile, 1,3,3-trimethyl-5-oxo; correction, 6668-6669

PROPOSED RULES

Air quality implementation plans; approval and promulgation; various States:
 Michigan, 6690-6691
 Texas, 6691

Superfund program:
 Toxic chemical release reporting; community right-to-know—
 Petition to add Standard Industrial Classification Code 45, transportation by air, to list of reporting facilities, 6691-6698

NOTICES

Agency information collection activities:
 Proposed collection; comment request, 6752-6754

Air programs:
 Ambient air monitoring reference and equivalent methods—
 Rupprecht & Patashnick Co., Inc., et al.; Partisol-FRM Model 2000, etc., 6754

Clean Air Act:
 Acid rain program—
 Sulfur dioxide emission reduction program, 6755

Grants and cooperative agreements; availability, etc.:
 Investigator-initiated grants program, 6755-6757
 Mobile source-related outreach projects, 6834-6837

Meetings:
 Scientific Counselors Board Executive Committee, 6757

Executive Office of the President

See Trade Representative, Office of United States

Farm Service Agency

RULES

Program regulations:
 Shared appreciation agreements; enforcement and collection, 6627-6629

Federal Aviation Administration

RULES

Aircraft products and parts; certification procedures:
 Primary category seaplanes; weight limit increase, 6808

Airworthiness directives:

Dornier, 6642-6643
 EXTRA Flugzeugbau GmbH, 6635-6636
 Glasflugel, 6629-6633
 HOAC Austria, 6633-6634
 McDonnell Douglas, 6639-6642
 SOCAT-A-Groupe AEROSPATIALE, 6636-6639

PROPOSED RULES

Air carrier certification and operations:
 Commercial passenger-carrying operations in single-engine aircraft; gyroscopic instrumentation redundant power; instrument flight rule clarification, 6826-6827

Airworthiness directives:

Aerospatiale, 6683-6685
 British Aerospace, 6682-6683
 EXTRA Flugzeugbau GmbH, 6689-6690
 Sikorsky, 6685-6689

Class B and C airspace, 6818-6823

NOTICES

Airport noise compatibility program:
 San Diego International Airport, CA, 6791-6792

Environmental statements; availability, etc.:
 General Mitchell International Airport, WI, 6792

Passenger facility charges; applications, etc.:
 Worcester Regional Airport, MA, 6792-6793

Federal Communications Commission

RULES

Frequency allocation and radio treaty matters:
 Television channels 60-69; 746-806 MHz band reallocation, 6669-6675

PROPOSED RULES

Radio stations; table of assignments:
 Kansas, 6699
 New York, 6698-6699

NOTICES

Agency information collection activities:
 Submission for OMB review; comment request, 6757-6758

Federal Crop Insurance Corporation

NOTICES

Grants and cooperative agreements; availability, etc.:
 Agricultural risk management education program, 6810-6816

Federal Deposit Insurance Corporation

NOTICES

Meetings; Sunshine Act, 6758-6759

Federal Energy Regulatory Commission

NOTICES

Electric rate and corporate regulation filings:
 Montaup Electric Co. et al., 6741-6747
 Pacific Gas & Electric Co. et al., 6747-6751

Environmental statements; notice of intent:
 Northern Natural Gas Co., 6751-6752

Applications, hearings, determinations, etc.:

Central Illinois Public Service Co., 6737
 Columbia Gulf Transmission Co., 6737-6738
 El Paso Natural Gas Co., 6738
 Mid Louisiana Gas Co., 6738
 NorAm Gas Transmission Co., 6738
 Northern Natural Gas Co., 6738-6739
 PG&E Gas Transmission, Northwest Corp., 6739
 Texas Gas Transmission Corp., 6739
 Union Electric Co., 6739
 Union Water Power Co., 6739-6740
 Williston Basin Interstate Pipeline Co., 6740
 Wyoming Interstate Co. Ltd., 6740

Federal Highway Administration**NOTICES**

Reports and guidance documents; availability, etc.:
 Minimum Uniform Crash Criteria, 6793

Federal Maritime Commission**NOTICES**

Agreements filed, etc., 6759
 Freight forwarder licenses:
 A.T.M.C. Inc., 6759

Federal Reserve System**NOTICES**

Banks and bank holding companies:
 Change in bank control, 6760
 Formations, acquisitions, and mergers, 6760
 Permissible nonbanking activities; correction, 6760

Fish and Wildlife Service**NOTICES**

Endangered and threatened species:
 Recovery plans—
 Star catus, 6765-6766
 Endangered and threatened species permit applications,
 6765
 Migratory bird hunting:
 International Tin Research Institute, Ltd; application for
 approval of tin shot as nontoxic for waterfowl
 hunting, 6766

Food and Drug Administration**RULES**

Animal drugs, feeds, and related products:
 New drug applications—
 Salinomycin, 6644
 Sponsor name and address changes—
 Phoenix Scientific, Inc., 6643-6644

NOTICES

Committees; establishment, renewal, termination, etc.:
 Antiviral Drugs Advisory Committee et al., 6761-6762
 Food additive petitions:
 Monsanto Co., 6762

Forest Service**NOTICES**

Environmental statements; availability, etc.:
 TransColorado Gas Transmission Co. pipeline project, CO
 and NM, 6767
 Meetings:
 Scientists Committee, 6704-6705

General Services Administration**NOTICES**

Federal Acquisition Regulation (FAR):
 . Agency information collection activities—
 Proposed collection; comment request, 6728
 Meetings:
 Aircraft Management Policy Advisory Board, 6761

Geological Survey**NOTICES**

World Energy Project; contribution acceptance from Exxon
 Exploration Co., 6766-6767

Health and Human Services Department

See Centers for Disease Control and Prevention
 See Food and Drug Administration

Housing and Urban Development Department**PROPOSED RULES**

HUD building products standards and certification
 program; use of materials bulletins, 6798-6805

NOTICES

Grants and cooperative agreements; availability, etc.:
 Small cities development block grants program, etc.—
 New York, 6762-6764
 Privacy Act:
 Systems of records, 6764-6765

Interior Department

See Fish and Wildlife Service
 See Geological Survey
 See Land Management Bureau
 See Reclamation Bureau
 See Surface Mining Reclamation and Enforcement Office

International Trade Administration**NOTICES**

Agency information collection activities:
 Proposed collection; comment request, 6721
 Antidumping:
 Titanium sponge from—
 Russian Federation et al., 6721-6722
 Scope rulings; list, 6722-6724

International Trade Commission**NOTICES**

Meetings; Sunshine Act, 6770-6771

Justice Department

See Drug Enforcement Administration

Labor Department

See Employment and Training Administration

Land Management Bureau**NOTICES**

Environmental statements; availability, etc.:
 TransColorado Gas Transmission Co. pipeline project, CO
 and NM, 6767
 Meetings:
 Resource advisory councils—
 Northeastern Great Basin, 6767
 Realty actions; sales, leases, etc.:
 Arizona, 6768

National Aeronautics and Space Administration**NOTICES**

Federal Acquisition Regulation (FAR):

- Agency information collection activities—
- Proposed collection; comment request, 6728

National Archives and Records Administration**NOTICES**

Agency information collection activities:

- Submission for OMB review; comment request, 6782

National Highway Traffic Safety Administration**NOTICES**

Reports and guidance documents; availability, etc.:

- Minimum uniform crash criteria, 6793

National Institute of Standards and Technology**NOTICES**

Grants and cooperative agreements; availability, etc.:

- Precision measurement program, 6724-6726

National Mediation Board**RULES**

Minimum conduct standards; CFR part removed, 6644-6645

National Oceanic and Atmospheric Administration**PROPOSED RULES**

Fishery conservation and management:

- Northeastern United States fisheries—
- Hake, 6699-6701
- New England Fishery Management Council; meetings, 6701-6702

NOTICES

Meetings:

- Pacific Fishery Management Council, 6726-6727

Permits:

- Marine mammals, 6727

National Skill Standards Board**NOTICES**

Meetings, 6782

Navy Department**NOTICES**

Inventions, Government-owned; availability for licensing, 6728-6731

Nuclear Regulatory Commission**NOTICES**

Agency information collection activities:

- Proposed collection; comment request, 6782-6783

Meetings; Sunshine Act, 6786-6787

Applications, hearings, determinations, etc.:

- Baltimore Gas & Electric Co., 6783-6784
- Duke Energy Corp., 6784-6786

Office of United States Trade Representative

See Trade Representative, Office of United States

Public Health Service

See Centers for Disease Control and Prevention

See Food and Drug Administration

Railroad Retirement Board**NOTICES**

Agency information collection activities:

- Proposed collection; comment request, 6787

Reclamation Bureau**NOTICES**

Environmental statements; notice of intent:

- Central Platte River Region, NE et al.; four threatened and endangered species; recovery implementation program, 6768-6770

Research and Special Programs Administration**RULES**

Pipeline safety:

- Hazardous liquid transportation—
- Older hazardous liquid and carbon dioxide pipelines; pressure testing; response to reconsideration petitions, 6677-6678

Risk Management Agency**NOTICES**

Grants and cooperative agreements; availability, etc.:

- Agricultural risk management education program, 6810-6816

Rural Business-Cooperative Service**RULES**

Program regulations:

- Shared appreciation agreements; enforcement and collection, 6627-6629

Rural Housing Service**RULES**

Program regulations:

- Shared appreciation agreements; enforcement and collection, 6627-6629

Rural Utilities Service**RULES**

Program regulations:

- Shared appreciation agreements; enforcement and collection, 6627-6629

Securities and Exchange Commission**NOTICES**

Self-regulatory organizations; proposed rule changes:

- Boston Stock Exchange, Inc., 6787-6788
- National Association of Securities Dealers, Inc., 6789-6790
- Philadelphia Stock Exchange, Inc., 6790

Small Business Administration**NOTICES**

Agency information collection activities:

- Submission for OMB review; comment request, 6790-6791

Surface Mining Reclamation and Enforcement Office**RULES**

Permanent program and abandoned mine land reclamation plan submissions:

- Mississippi; correction, 6796

Textile Agreements Implementation Committee

See Committee for the Implementation of Textile Agreements

Trade Representative, Office of United States**NOTICES**

Meetings:

- Industry Sector Advisory Committees—
- Small and minority business, 6791

Transportation Department

See Federal Aviation Administration
See Federal Highway Administration
See National Highway Traffic Safety Administration
See Research and Special Programs Administration

Treasury Department**NOTICES**

Agency information collection activities:
Submission for OMB review; comment request, 6793-6794

United States Information Agency**NOTICES**

Art objects; importation for exhibition:
Conversion by Candlelight: The Four Magdalens by Georges de la Tour, 6794-6795

Separate Parts In This Issue**Part II**

Department of Housing and Urban Development, 6798-6805

Part III

Department of Transportation, Federal Aviation Administration, 6808

Part IV

Department of Agriculture, Cooperative State Research, Education, and Extension Service, Federal Crop Insurance Corporation, Risk Management Agency 6810-6816

Part V

Department of Transportation, Federal Aviation Administration, 6818-6823

Part VI

Department of Transportation, Federal Aviation Administration, 6826-6827

Part VII

Department of Education, 6830-6831

Part VIII

Environmental Protection Agency, 6834-6837

Reader Aids

Additional information, including a list of telephone numbers, finding aids, reminders, and a list of Public Laws appears in the Reader Aids section at the end of this issue.

Electronic Bulletin Board

Free **Electronic Bulletin Board** service for Public Law numbers, **Federal Register** finding aids, and a list of documents on public inspection is available on 202-275-1538 or 275-0920.

CFR PARTS AFFECTED IN THIS ISSUE

A cumulative list of the parts affected this month can be found in the Reader Aids section at the end of this issue.

7 CFR	
1951.....	6627
Proposed Rules:	
911.....	6679
915.....	6679
14 CFR	
21.....	6808
39 (7 documents).....	6629, 6633, 6635, 6636, 6638, 6639, 6642
Proposed Rules:	
39 (4 documents).....	6682, 6683, 6685, 6689
71.....	6818
135.....	6826
21 CFR	
522.....	6643
529.....	6643
558.....	6644
24 CFR	
Proposed Rules:	
200.....	6798
29 CFR	
1200.....	6644
30 CFR	
924.....	6796
40 CFR	
51.....	6645
52 (11 documents).....	6645, 6646, 6647, 6648, 6649, 6650, 6651, 6653, 6659, 6664
62.....	6664
81.....	6664
180.....	6665
186.....	6665
271.....	6666
281.....	6667
372.....	6668
721.....	6668
Proposed Rules:	
52 (2 documents).....	6690, 6691
372.....	6691
47 CFR	
2.....	6669
Proposed Rules:	
73 (2 documents).....	6698, 6699
48 CFR	
1515.....	6675
1552 (2 documents).....	6675, 6676
49 CFR	
195.....	6677
50 CFR	
Proposed Rules:	
648 (2 documents).....	6699, 6701

Rules and Regulations

Federal Register

Vol. 63, No. 27

Tuesday, February 10, 1998

This section of the FEDERAL REGISTER contains regulatory documents having general applicability and legal effect, most of which are keyed to and codified in the Code of Federal Regulations, which is published under 50 titles pursuant to 44 U.S.C. 1510.

The Code of Federal Regulations is sold by the Superintendent of Documents. Prices of new books are listed in the first FEDERAL REGISTER issue of each week.

DEPARTMENT OF AGRICULTURE

Rural Housing Service

Rural Business-Cooperative Service

Rural Utilities Service

Farm Service Agency

7 CFR Parts 1951

RIN 0560-AE61

Enforcement and Collection of Shared Appreciation Agreements

AGENCIES: Rural Housing Service, Rural Business-Cooperative Service, Rural Utilities Service, Farm Service Agency, USDA.

ACTION: Final rule.

SUMMARY: The Farm Service Agency (FSA) is amending its direct Farm Loan Programs loan servicing regulations to clarify the requirements for collecting on a Shared Appreciation Agreement (SAA). The intended effect is to reduce losses to the Government caused by litigation expenses and delays in account collection.

EFFECTIVE DATE: March 12, 1998.

FOR FURTHER INFORMATION CONTACT: Kimberly R. Laris, Senior Loan Officer, Farm Loan Programs Loan Servicing Division, Farm Service Agency (FSA), U.S. Department of Agriculture, STOP 0523, 1400 Independence Ave., SW, Washington, D.C. 20250-0523; Telephone: 202-720-1649; Facsimile: 202-690-0949; E-mail: klaris@usda.fsa.gov.

SUPPLEMENTARY INFORMATION:

Executive Order 12866

This rule has been determined not significant for the purposes of E.O. 12866 and has not been reviewed by OMB.

Executive Order 12372

1. For the reasons contained in the final rule related Notice to 7 CFR part 3015, subpart V (48 FR 29115, June 24, 1983), Farm Ownership Loans, Farm Operating Loans, and Emergency Loans are excluded from the scope of E.O. 12372, which requires intergovernmental consultation with State and local officials.

2. The Soil and Water Loan Program is subject to and has met the provisions of E.O. 12372 in accordance with FmHA Instruction 1940-J.

Federal Assistance Program

These changes affect the following FSA programs as listed in the Catalog of Federal Domestic Assistance:

- 10.404—Emergency Loans
- 10.406—Farm Operating Loans
- 10.407—Farm Ownership Loans
- 10.416—Soil and Water Loans

Environmental Impact Statement

This document has been reviewed in accordance with 7 CFR part 1940, subpart G, "Environmental Program." The issuing agencies have determined that this action does not significantly affect the quality of human environment, and in accordance with the National Environmental Policy Act of 1969, Pub L. 91-190, an Environmental Impact Statement is not required.

Executive Order 12988

This final rule has been reviewed in accordance with E.O. 12988, Civil Justice Reform. In accordance with this rule: (1) State and local laws and regulations that are in conflict with this rule will be preempted; (2) no retroactive effect will be given to this rule; and (3) administrative proceedings in accordance with 7 CFR parts 11 and 780 must be exhausted before bringing suit in court challenging action taken under this rule.

Paperwork Reduction Act of 1995

This final rule does not impose any new information or record keeping requirements on the public that require clearance by the OMB under the provisions of 44 U.S.C. chapter 35.

Regulatory Flexibility Act

The issuing agencies certify that this rule will not have a significant economic impact on a substantial

number of small entities as defined in the Regulatory Flexibility Act, Public Law 96-534, as amended (5 U.S.C. 601). This rule will not increase or decrease the action required by small business entities. Amendments included in this rule also will not impact small entities to a greater extent than large entities or individual farm borrowers.

Unfunded Mandates Reform Act of 1995

Title II of the Unfunded Mandates Reform Act of 1995 (UMRA), Public Law 104-4, establishes requirements for Federal agencies to assess the effects of their regulatory actions on State, local, and tribal governments and the private sector of \$100 million or more in any 1 year. When such statement is needed for a rule, section 205 of the UMRA, FSA generally must prepare a written statement, including a cost-benefit analysis, for proposed and final rules with "Federal mandates" that may result in expenditures to State, local, and tribal governments, in the aggregate, or to the private sector. When such a statement is needed for a rule, section 205 of the UMRA generally requires FSA to identify and consider a reasonable number of regulatory alternatives and adopt the least costly, more cost effective or least burdensome alternative that achieves the objectives of the rule.

This rule contains no Federal mandates (under the regulatory provisions of Title II of the UMRA) for State, local, and tribal governments or the private sector. Thus, this rule is not subject to the requirements of sections 202 and 205 of the UMRA.

National Performance Review

This rule has been reviewed in accordance with the National Performance Review.

Discussion of Final Rule

These changes involve the Farm Loan Programs (FLP) loans of FSA formerly administered by the Farmers Home Administration (FmHA) as Farmer Programs loans.

This rule amends 7 CFR part 1951 subpart S which was published in its entirety as an interim rule with a request for comments (53 FR 35638-35798, September 14, 1988) to implement the requirements of the Agricultural Credit Act of 1987. A second interim rule with a request for

comments (57 FR 18612, April 30, 1992) was published to implement amendments made by the Food, Agriculture, Conservation, and Trade Act of 1990. This rule is being published in response to comments received on these interim rules and to make minor clarifications. In addition, the Office of Management and Budget control number assigned for the approval of information collections is being revised to reflect the transfer of the public reporting burden from the Farmers Home Administration to the Farm Service Agency in accordance with the provisions of the Federal Crop Insurance Reform and Department of Agriculture Reorganization Act of 1994 (Pub. L. 103-354).

As a condition to, and in consideration of, having a portion of their debt written down and their loans restructured, a borrower must execute an SAA. FSA collects a portion of the written off debt from appreciation of the real estate security when the property is sold, the loans are paid or the farmer quits farming. Current regulations are written so as to allow collection on an SAA only after transfer of title. The present wording has resulted in the interpretation that property must be foreclosed upon in order to effect a change in title before SAA can be enforced. This requires filing an additional civil action after foreclosure to collect proceeds that result from value appreciation of the security. This results in decreased collections on SAA's and increased litigation costs. This rule clarifies that acceleration of the loan triggers acceleration of the SAA.

Comments were received from a State commissioner of agriculture, a State rural action organization, a legal services organization, and the National Family Farm Coalition. Two commenters recommended that FSA clarify that a borrower may pay the amount due under an SAA in installments and that the debt arising out of this agreement may be serviced as an Agency loan. This recommendation has been adopted in this rule. Another commenter suggested that the regulation address how shared appreciation is to be handled when there is only a partial sale of the real estate securing the SAA. This recommendation has also been adopted and the necessary changes are made by this rule. A commenter also recommended that the SAA contain the amounts of appreciation to be recaptured and the actions that trigger the agreement. This recommendation has also been adopted. Another commenter recommended that the Agency requirement that real estate

records be reviewed biannually be revised to require that records be reviewed after expiration of the agreement. This suggestion was adopted. The requirement that records be reviewed after expiration of the agreement is not included in the final rule since it is an internal Agency policy directive.

Additionally, FSA is proposing to remove administrative processes from the regulations leaving only regulatory actions which impact the public. Also, some paragraphs are reorganized and wording changes are made to make the regulation more concise and easier to read and understand. FSA is developing a separate handbook to address internal operating procedures. This handbook will not be published in the Federal Register, but will be available to the public upon request.

For example, in this rule, FSA is removing the specific references to Exhibit D, "Shared Appreciation Agreement," which is being made into Form FSA 1951-64. FSA will continue to use these types of specialized forms. However, since these matters involve internal operating procedures, the form will be contained in FSA's internal instructions only, with the regulation referencing only that a form will be executed. Other clarifications are made on how to execute, service and collect Shared Appreciation Agreements. This change will clarify that acceleration of the loan triggers acceleration of the SAA.

List of Subjects in 7 CFR Part 1951

Account servicing, Debt restructuring, Credit, Loan programs—agriculture, Loan programs—housing and community development, Low and moderate income housing loans—servicing.

For the reasons stated in the preamble, the Farm Service Agency amends 7 CFR, part 1951 as follows:

PART 1951—SERVICING AND COLLECTIONS

1. The authority citation for part 1951 continues to read as follows:

Authority: 5 U.S.C. 301; 7 U.S.C. 1989; and 42 U.S.C. 1480.

Subpart S—Farm Loan Programs Account Servicing Policies

2. Section 1951.901 is amended by adding a new sentence after the second sentence to read as follows:

§ 1951.901 Purpose.

* * * Shared Appreciation Loans (SA) may be reamortized under this subpart if the borrower also has

outstanding Farm Loan Programs loans. * * *

3. Section 1951.909 is amended by revising paragraphs (e)(2)(viii), (e)(2)(vii) introductory text, and (e)(2)(viii)(A), (h)(3)(viii), and (j) to read as follows and by removing paragraphs (k), (l), and (m):

§ 1951.909 Processing primary loan service programs requests.

(e) * * *
(2) * * *

(vii) Reamortized installments usually will be scheduled for repayment within the remaining time period of the note or assumption agreement being reamortized. If repayment is extended, the new repayment period plus the period the loan has been in effect may not exceed the maximum number of years for that type of loan as set forth below, or the useful life of the security, whichever is less:

(A) FO, SW, RL, EE, and EM loans may not exceed 40 years from the date of the original note or assumption agreement.

(B) EE loans for real estate purposes, which are secured by chattels only, may be reamortized over a period not to exceed 20 years from the date of the original note or assumption agreement.

(C) RHF loans may not exceed 33 years from the date of the original note or assumption agreement.

(D) SA loans may not exceed 25 years from the date of the original amortized note.

(viii) The interest rate will be as follows:

(A) The interest rate will be the current interest rate in effect on the date of reamortization (the date the new note is signed by the borrower), or the interest rate on the original Promissory Note to be reamortized, whichever is less. In the case of a limited resource loan, it will be the limited resource FO or SW loan rate or the original loan note rate, whichever is less. SA loans will be reamortized at the current nonprogram interest rate in effect on the date of reamortization or the nonprogram interest rate on the original amortized note, whichever is less.

* * * * *
(h) * * *
(3) * * *

(viii) Upon payment by the borrower of current market value buyout, the security instruments will be released for the Farm Loan Programs loans bought out.

* * * * *

(j) *Processing of writedown.* The DALRS computer program will be used to determine the notes and amount to be written down. The borrower's account

will be credited for the amount written down and the loans remaining after writedown will be rescheduled or reamortized.

(1) A separate note will be signed for each loan being reamortized.

(2) If any loan written down was secured by real estate, the borrower must enter into a "Shared Appreciation Agreement." This agreement provides for FSA to collect back all or part of the amount written down by taking a share in any positive appreciation in the value of the real property securing the SAA and the remaining debt after the writedown. The maximum amount of shared appreciation collected will not exceed the amount written down. If a borrower's FLP loan was not secured by real estate, the borrower will not be required to enter into a shared appreciation agreement.

(3) A lien will be taken on assets in accordance with § 1951.910. The Agency's real estate liens will be maintained even if the writedown of the borrower's debt results in all real estate debts to the Agency being written down. The Agency's real estate lien will not be subordinated to increase the amount of the prior liens during the shared appreciation period.

4. Section 1951.914 is amended to read as follows:

§ 1951.914 Servicing Shared Appreciation Agreements.

(a) [Reserved]

(b) *When shared appreciation is due.* Shared appreciation is due at the end of the term of the Shared Appreciation Agreement, or sooner, if one of the following events occurs:

(1) The sale or conveyance of any or all the real estate security, including gift, contract for sale, purchase agreement, or foreclosure. Transfer to the spouse of the borrower in case of the death of the borrower will not be treated as a conveyance; until the spouse further conveys the property;

(2) Repayment of the loans; or the loans are otherwise satisfied;

(3) The borrower or surviving spouse ceases farming operations or no longer receives farm income, including lease income; or

(4) The notes are accelerated.

(c) *Determining the amount of shared appreciation due.* (1) The current market value of the real estate property will be determined based on a current appraisal. If only a portion of the real estate is sold, an appraisal will only be done on the real estate being considered for release. For these cases, an appraisal may be required to determine the market value of the property at the time the SAA was signed if such value

cannot be obtained through another method.

(2) [Reserved]

(3) Shared appreciation will be due if there is a positive difference between the market value of the security property at the time of calculation and the market value of the security property as of the date of the SAA. The maximum appreciation requested will not be more than the total amount written down. The amount of shared appreciation will be:

(i) 75% of any positive appreciation if any one of the events listed in paragraphs (b)(1) through (4) of this section occur within 4 years or less from the date of the SAA; or

(ii) 50% of any positive appreciation if any one of the events listed in paragraphs (b)(1) through (4) of this section occurs more than 4 years from the date of the SAA, or if the term of the SAA expires.

(4) [Reserved]

(5) When the full amount of the appreciation due under this section and any remaining FSA debt is paid in full and credited to the account, the borrower will be released from liability.

(6) Shared appreciation that will become due will be included in the amount owed to FSA, such as with any debt settlement. Nonamortized shared appreciation may be assumed and amortized on program or nonprogram terms based on the transferee's eligibility as contained in subpart A of part 1965 of this chapter.

(d) [Reserved]

(e) *Shared appreciation amortization.* Shared appreciation may be amortized to a nonprogram loan for borrowers who will continue with FSA on program loans. Shared appreciation will not be amortized if the amount is due because of acceleration, payment in full or satisfaction of the debt, or the borrower ceases farming. The amount due may be amortized as an SA loan under the following conditions:

(1) The borrower must have a feasible plan as defined in § 1951.906 including the SA loan payment.

(2) The borrower must be unable to pay the shared appreciation, or obtain the funds elsewhere to pay the shared appreciation.

(3) [Reserved]

(4) [Reserved]

(5) The loan term will be based on the borrower's repayment ability and the life of the security, not to exceed 25 years.

(6) The interest rate will be the nonprogram real property rate contained in RD Instruction 440.1 (available in any FSA office.)

(7) A lien will be obtained on any remaining FSA security, or if there is no

security remaining, the best lien obtainable on any other real estate or chattel property sufficient to secure the SA note, if available.

(8) The borrower will sign a promissory note for each SA loan established.

(9) If the borrower has outstanding FLP loans, and becomes delinquent or financially distressed as defined in § 1951.906, the SA loan may be considered for reamortization as set forth in § 1951.909(e).

(f) *Priority of collection application.* Proceeds from the sale of security property will first be applied to any prior lienholder's debt, then to any shared appreciation due, and to the balance of outstanding FLP loans in accordance with subpart A of this part.

(g) *Subordination.* Subordination of FSA's lien on property securing the Shared Appreciation Agreement may be approved and processed in accordance with subpart A of part 1965 of this chapter provided the prior lien debt is not increased.

5. Section 1951.950 is amended to revise the OMB control number "0575-0133" in the first and last sentences to read "0560-0161".

6. Exhibit D is removed and reserved.

Signed in Washington, D.C., on January 26, 1998.

August Schumacher, Jr.,

Under Secretary for Farm and Foreign Agricultural Services.

[FR Doc. 98-3314 Filed 2-9-98; 8:45 am]

BILLING CODE 3410-05-P

DEPARTMENT OF TRANSPORTATION

Federal Aviation Administration

14 CFR Part 39

[Docket No. 96-CE-35-AD; Amendment 39-10213; AD 97-24-06]

RIN 2120-AA64

Airworthiness Directives; Glasflugel Models Standard Libelle and Standard Libelle 201 B Sailplanes

AGENCY: Federal Aviation Administration, DOT.

ACTION: Final rule.

SUMMARY: This amendment adopts a new airworthiness directive (AD) that applies to Glasflugel Models Standard Libelle and Standard Libelle 201 B sailplanes. This action requires inspecting the aileron operating lever's actuating shaft welded seams for cracks; modifying or replacing the actuating shaft, if cracked; and, if no cracks are found, eventually modifying or

replacing the shaft. Cracks found in the welded seams of the actuating shaft prompted this action. The actions specified by this AD are intended to prevent cracks in the aileron operating lever's actuating shaft welded seams, which, if not detected and corrected, could cause loss of control of the sailplane.

DATES: Effective March 13, 1998.

ADDRESSES: Service information that pertains to this AD may be obtained from Glasflugel, c/o H. Streifeneder, Glasfaser-Flugzeug Service GmbH, Hofener Weg, D-72582 Grabenstetten, Germany. This information may also be examined at the Federal Aviation Administration (FAA), Central Region, Office of the Regional Counsel, Attention: Rules Docket 96-CE-35-AD, Room 1558, 601 E. 12th Street, Kansas City, Missouri 64106.

FOR FURTHER INFORMATION CONTACT: Mr. J. Mike Kiesov, Project Officer, Sailplanes, FAA, Small Airplane Directorate, 1201 Walnut, suite 900, Kansas City, Missouri 64106; telephone (816) 426-6932, facsimile (816) 426-2169.

SUPPLEMENTARY INFORMATION:

Events Leading to the Issuance of This AD

A proposal to amend part 39 of the Federal Aviation Regulations (14 CFR part 39) to include an AD that would apply to Glasflugel Models Standard Libelle and Standard Libelle 201 B Sailplanes was published in the *Federal Register* on December 10, 1996 (61 FR 65006). The action proposed to require inspecting the aileron operating lever's actuating shaft welded seams for cracks. If cracks are found, the proposal specifies repairing and modifying, or replacing the actuating shaft. If no cracks are found, the actuating shaft would be modified or replaced at a later time. Accomplishment of these actions was proposed in accordance with the Glasfaser-Flugzeug-Service GmbH Technical Note (TN) 201-33, dated March 4, 1996. Based upon the difficulty in obtaining the above-referenced technical note for U.S. operators of the affected airplanes, the FAA is revising the proposal to include an AD appendix which incorporates the Accomplishment Instructions and Figures of the Glasfaser-Flugzeug GbmH Technical Note TN 201-33, dated March 4, 1996.

Interested persons have been afforded an opportunity to participate in the making of this amendment. No comments were received on the proposed rule or the FAA's determination of the cost to the public.

The FAA's Determination

After careful review of all available information related to the subject presented above including the referenced service information, the FAA has determined that air safety and the public interest require the adoption of the rule as proposed, except for the addition of the appendix described above and minor editorial corrections.

Cost Impact

The FAA estimates that 108 sailplanes in the U.S. registry will be affected by this AD; that it will take approximately 4 workhours per sailplane to accomplish the inspection, repair and modification; or that it will take 3 workhours per sailplane to inspect and replace the lever shaft; and that the average labor rate is estimated to be approximately \$60 an hour. Material cost for the modification is approximately \$10 per sailplane, and a replacement shaft part costs \$140 per sailplane. Based on these figures, the total cost impact of this AD on U.S. operators is estimated to be \$27,000 (\$250 per sailplane) if all shafts are modified, or \$34,560 (\$320 per sailplane) if all shafts are replaced. This figure is based on the presumption that no affected sailplane owner/operator has accomplished the inspection or modification.

Regulatory Impact

The regulations adopted herein will not have substantial direct effects on the States, on the relationship between the national government and the States, or on the distribution of power and responsibilities among the various levels of government. Therefore, in accordance with Executive Order 12612, it is determined that this final rule does not have sufficient federalism implications to warrant the preparation of a Federalism Assessment.

For the reasons discussed above, I certify that this action (1) is not a "significant regulatory action" under Executive Order 12866; (2) is not a "significant rule" under DOT Regulatory Policies and Procedures (44 FR 11034, February 26, 1979); and (3) will not have a significant economic impact, positive or negative, on a substantial number of small entities under the criteria of the Regulatory Flexibility Act. A copy of the final evaluation prepared for this action is contained in the Rules Docket. A copy of it may be obtained by contacting the Rules Docket at the location provided under the caption ADDRESSES.

List of Subjects in 14 CFR Part 39

Air transportation, Aircraft, Aviation safety, Safety.

Adoption of the Amendment

Accordingly, pursuant to the authority delegated to me by the Administrator, the Federal Aviation Administration amends part 39 of the Federal Aviation Regulations (14 CFR part 39) as follows:

PART 39—AIRWORTHINESS DIRECTIVES

1. The authority citation for part 39 continues to read as follows:

Authority: 49 U.S.C. 106(g), 40113, 44701.

§ 39.13 [Amended]

2. Section 39.13 is amended by adding a new airworthiness directive (AD) to read as follows:

97-24-06. Glasflugel: Amendment 39-10213; Docket No. 96-CE-35-AD.

Applicability: Models Standard Libelle and Standard Libelle 201 B Sailplanes (all serial numbers), certificated in any category.

Note 1: This AD applies to each sailplane identified in the preceding applicability provision, regardless of whether it has been modified, altered, or repaired in the area subject to the requirements of this AD. For sailplanes that have been modified, altered, or repaired so that the performance of the requirements of this AD is affected, the owner/operator must request approval for an alternative method of compliance in accordance with paragraph (e) of this AD. The request should include an assessment of the effect of the modification, alteration, or repair on the unsafe condition addressed by this AD; and, if the unsafe condition has not been eliminated, the request should include specific proposed actions to address it.

Compliance: Required as indicated in the body of this AD, unless already accomplished.

To prevent cracks in the aileron operating lever's actuating shaft welded seams, which, if not detected and corrected, could cause loss of control of the sailplane, accomplish the following:

(a) Within the next 30 calendar days after the effective date of this AD, inspect for cracks in the paint of the aileron operating lever's actuating shaft welded seams using a magnifying glass (2x minimum) and a flashlight, and if there are cracks in the paint, then prior to further flight, remove the actuating shaft and perform a dye-penetrant inspection for cracks in accordance with Method 1 in the Accomplishment Instructions section and Figure 1 of the Appendix to this AD.

(1) If cracks are seen in the actuating shaft, prior to further flight, either:

(i) Repair any cracked welded seams, and modify the shaft in accordance with Method 2 of the Accomplishment Instructions and Figure 2 in the Appendix of this AD; or

(ii) Remove and replace the shaft with a new Glasflugel reinforced shaft in accordance

with Figure 1 and Method 3 in the Accomplishment Instructions in the Appendix of this AD.

(2) If no cracks are found, within the next 3 calendar months after the inspection required by paragraph (a) of this AD, either:

(i) Modify the aileron operating lever's shaft in accordance with Method 2 of the Accomplishment Instructions in the Appendix of this AD; or,

(ii) Remove and replace the shaft with a new Glasflügel reinforced shaft in accordance with Method 3 in the Accomplishment Instructions and Figure 1 in the Appendix of this AD.

Note 2: The FAA recommends that the shafts be finished with zinc-chromate primer and paint with a grayish-green shade.

(b) After completing any action described in paragraph (a) or any sub-paragraph of (a) in this AD, prior to further flight, check and adjust the aileron deflection range in accordance with the "Remarks" paragraph in the Accomplishment Instructions in the Appendix of this AD.

(c) Accomplishing all of the actions specified in the Accomplishment Instructions section of Glasfaser-Flugzeug Service GmbH Technical Note 201-33, dated March 4, 1996, incorporates the intent of this AD. No further action is required.

(d) Special flight permits may be issued in accordance with sections 21.197 and 21.199 of the Federal Aviation Regulations (14 CFR 21.197 and 21.199) to operate the sailplane to a location where the requirements of this AD can be accomplished.

(e) An alternative method of compliance or adjustment of the compliance times that provides an equivalent level of safety may be approved by the Manager, Small Airplane Directorate, 1201 Walnut, suite 900, Kansas City, Missouri 64106. The request shall be

forwarded through an appropriate FAA Maintenance Inspector, who may add comments and then send it to the Manager, Small Airplane Directorate.

Note 3: Information concerning the existence of approved alternative methods of compliance with this AD, if any, may be obtained from the Small Airplane Directorate.

(f) Information related to this AD may be examined at the FAA, Central Region, Office of the Regional Counsel, Room 1558, 601 E. 12th Street, Kansas City, Missouri.

Appendix to AD 97-24-06—Aileron Actuating Shaft

Accomplishment Instructions

Method 1:

Note: The term "WIG-inert protective atmosphere welding system" used within the Appendix text has the U.S. equivalent of Tungsten Inert Gas (TIG) welding system.

Using a magnifying glass (2x minimum) and a flashlight, inspect the aileron actuating shaft in the fuselage (see Figure 1) near the welding seams for cracks in the paint. If there is any cracked paint on the actuating shaft, prior to further flight, remove the actuating shaft and inspect for cracks in the shaft and welding seams using a dye-penetrant method. If there are no cracks or any other damage, flying operation can continue until the accumulation of 8 calendar months after the initial inspection required by this AD, at which time Method 2 or Method 3 shall be accomplished. If cracks are found, prior to further flight, accomplish Method 2 or Method 3.

Note: In Figure 2, the doubler has physical dimensions of: 90 mm x 12 mm x 1 mm, with the ends having a radius of 6 mm.

Appendix to AD 97-24-06—Aileron Actuating Shaft

Method 2:

Remove all paint. Weld (groove welding) all cracks. Weld the joints with the WIG-inert protective atmosphere welding system (wolfram inert gas welding system) with welding material 1.7734.2. Weld the plates (position 7) to the actuating shaft according to Figure 2. Finish the actuating shaft with primer and paint (paint type RAL 7003). Reinstall the aileron actuating shaft.

Note: Method 2 in the Appendix refers to welding material 1.7734.2. The FAA and the LBA were unable to determine the U.S. equivalent to this material. The recommended options would be to order the original part from the manufacturer, order the welding material from the manufacturer, or order welding material 1.7734.2 from Germany, Italy or France.

Method 3:

As an alternative to Method 2, replace the original actuating shaft with a new reinforced shaft according to Figure 1.

Mass and balance: Not Affected.

Appendix to AD 97-24-06—Aileron Actuating Shaft

Remarks

For rigging and derigging procedures, refer to the flight manual, page E12. After accomplishing repairs according to Method 2, or replacement of the actuating shaft according to Method 3, the aileron deflections must be checked. Plates, welding material, and spare parts as mentioned are available from the manufacturer.

BILLING CODE 4910-13-P

Appendix to AD 97-24-06

Aileron Actuating Shaft

FIGURE 1

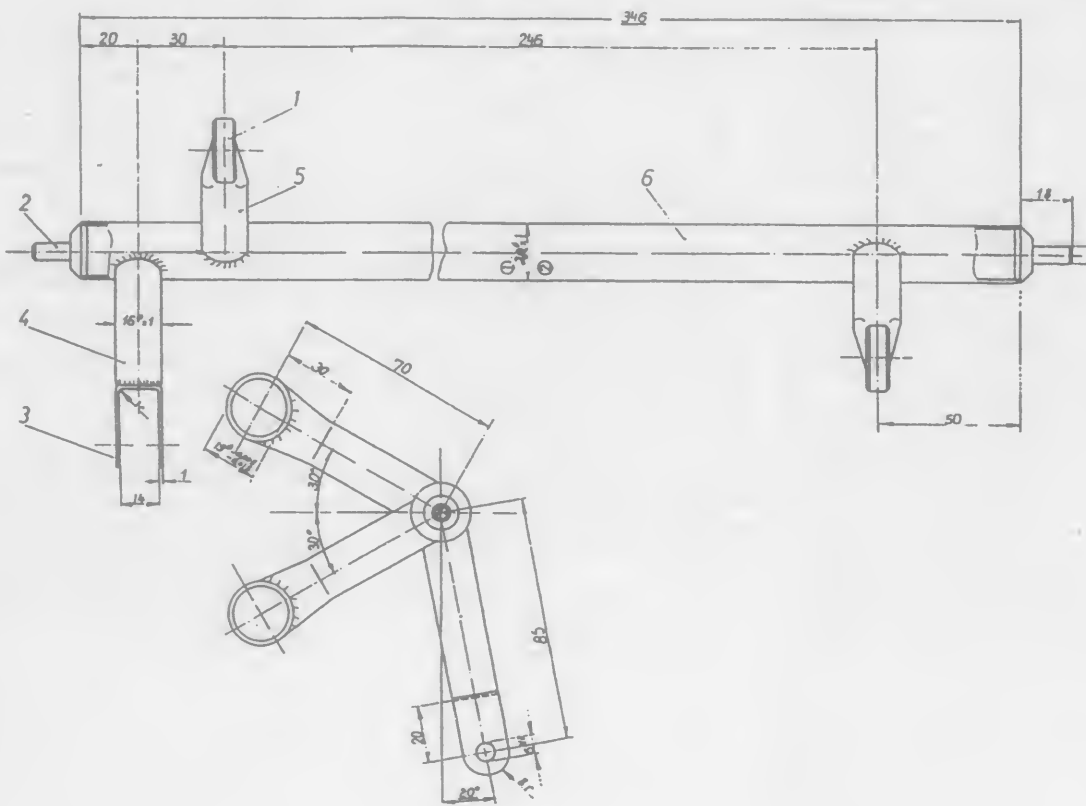

Appendix to AD 97-24-06

Aileron Actuating Shaft

FIGURE 2

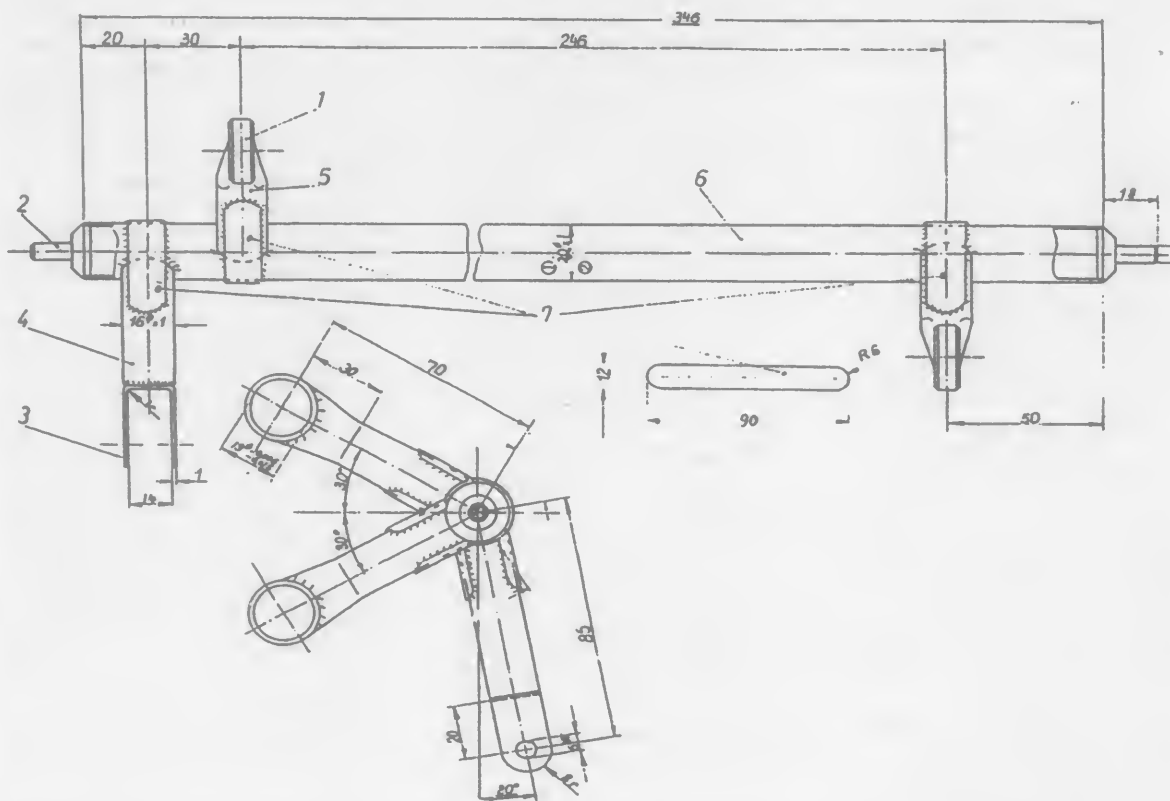

(g) This amendment (39-10213) becomes effective on March 13, 1998.

Issued in Kansas City, Missouri, on February 2, 1998.

Carolanne L. Cabrini,

Acting Manager, Small Airplane Directorate,
Aircraft Certification Service.

[FR Doc. 98-3130 Filed 2-9-98; 8:45 am]

BILLING CODE 4910-13-C

DEPARTMENT OF TRANSPORTATION
Federal Aviation Administration

14 CFR Part 39

[Docket No. 97-CE-84-AD; Amendment 39-10315; AD 98-04-02]

RIN 2120-AA64

**Airworthiness Directives; HOAC
Austria Model DV 20 Katana Airplanes**

AGENCY: Federal Aviation
Administration, DOT.

ACTION: Final rule.

SUMMARY: This amendment adopts a new airworthiness directive (AD) that applies to HOAC Austria Model DV 20 Katana airplanes. This AD requires replacing the nose wheel leg of the nose

landing gear (NLG) with a part of improved design. This AD is the result of mandatory continuing airworthiness information (MCAI) issued by the airworthiness authority for Austria. The actions specified by this AD are intended to prevent NLG collapse caused by cracks in the welding of the nose wheel tappet of the NLG, which could result in the inability to control the airplane during landing, takeoff, and other ground operations.

EFFECTIVE DATE: March 24, 1998.

ADDRESSES: Service information that relates to this AD may be obtained from Diamond Aircraft Industries, G.m.b.H., N.A. Otto-Strabe 5, A-2700, Wiener Neustadt, Austria. This information may also be examined at the Federal Aviation Administration (FAA), Central

Region, Office of the Regional Counsel, Attention: Rules Docket No. 97-CE-84-AD, Room 1558, 601 E. 12th Street, Kansas City, Missouri 64106.

FOR FURTHER INFORMATION CONTACT: Mr. Roger P. Chudy, Aerospace Engineer, Small Airplane Directorate, Aircraft Certification Service, FAA, 1201 Walnut, suite 900, Kansas City, Missouri 64106; telephone: (816) 426-6934; facsimile: (816) 426-2169.

SUPPLEMENTARY INFORMATION:

Events Leading to the Issuance of This AD

A proposal to amend part 39 of the Federal Aviation Regulations (14 CFR part 39) to include an AD that would apply to HOAC Austria Model DV 20 Katana airplanes was published in the *Federal Register* as a notice of proposed rulemaking (NPRM) on November 7, 1997 (62 FR 60183). The NPRM proposed to require replacing the nose wheel leg of the NLG with a part of improved design, nose wheel leg version "B", in accordance with the applicable maintenance manual.

The NPRM was the result of mandatory continuing airworthiness information (MCAI) issued by the airworthiness authority for Austria.

Interested persons have been afforded an opportunity to participate in the making of this amendment. No comments were received on the proposed rule or the FAA's determination of the cost to the public.

The FAA's Determination

After careful review of all available information related to the subject presented above, the FAA has determined that air safety and the public interest require the adoption of the rule as proposed except for minor editorial corrections. The FAA has determined that these minor corrections will not change the meaning of the AD and will not add any additional burden upon the public than was already proposed.

Cost Impact

The FAA estimates that 20 airplanes in the U.S. registry will be affected by this AD, that it will take approximately 1 workhour per airplane to accomplish the required replacement, and that the average labor rate is approximately \$60 per hour. Parts cost approximately \$900 per airplane. Based on these figures, the total cost impact of this AD on U.S. operators is estimated to be \$19,200, or \$960 per airplane.

Regulatory Impact

The regulations adopted herein will not have substantial direct effects on the States, on the relationship between the national government and the States, or on the distribution of power and responsibilities among the various levels of government. Therefore, in accordance with Executive Order 12612, it is determined that this final rule does not have sufficient federalism implications to warrant the preparation of a Federalism Assessment.

For the reasons discussed above, I certify that this action (1) is not a "significant regulatory action" under Executive Order 12866; (2) is not a "significant rule" under DOT Regulatory Policies and Procedures (44 FR 11034, February 26, 1979); and (3) will not have a significant economic impact, positive or negative, on a substantial number of small entities under the criteria of the Regulatory Flexibility Act. A copy of the final evaluation prepared for this action is contained in the Rules Docket. A copy of it may be obtained by contacting the Rules Docket at the location provided under the caption ADDRESSES.

List of Subjects in 14 CFR Part 39

Air transportation, Aircraft, Aviation safety, Safety.

Adoption of the Amendment

Accordingly, pursuant to the authority delegated to me by the Administrator, the Federal Aviation Administration amends part 39 of the Federal Aviation Regulations (14 CFR part 39) as follows:

PART 39—AIRWORTHINESS DIRECTIVES

1. The authority citation for part 39 continues to read as follows:

Authority: 49 U.S.C. 106(g), 40113, 44701.

§ 39.13 [Amended]

2. Section 39.13 is amended by adding a new airworthiness directive (AD) to read as follows:

98-04-02 Hoac Austria: Amendment 39-10315; Docket No. 97-CE-84-AD.

Applicability: Model DV 20 Katana airplanes, serial numbers 20.005 through 20.160, certificated in any category.

Note 1: This AD applies to each airplane identified in the preceding applicability provision, regardless of whether it has been modified, altered, or repaired in the area subject to the requirements of this AD. For airplanes that have been modified, altered, or repaired so that the performance of the requirements of this AD is affected, the owner/operator must request approval for an

alternative method of compliance in accordance with paragraph (c) of this AD. The request should include an assessment of the effect of the modification, alteration, or repair on the unsafe condition addressed by this AD; and, if the unsafe condition has not been eliminated, the request should include specific proposed actions to address it.

Compliance: Required within the next 100 hours time-in-service (TIS) after the effective date of this AD, unless already accomplished.

To prevent nose landing gear (NLG) collapse caused by cracks in the welding of the nose wheel tappet of the NLG, which could result in the inability to control the airplane during landing, takeoff, and other ground operations, accomplish the following:

(a) Replace the nose wheel leg of the NLG with a part of improved design, nose wheel leg version "B", in accordance with the applicable maintenance manual.

Note 2: Diamond Aircraft Industries Service Bulletin No. 20-32, dated April 5, 1996, specifies the replacement required by this AD for the HOAC Austria Model DV 20 Katana airplanes.

(b) Special flight permits may be issued in accordance with sections 21.197 and 21.199 of the Federal Aviation Regulations (14 CFR 21.197 and 21.199) to operate the airplane to a location where the requirements of this AD can be accomplished.

(c) An alternative method of compliance or adjustment of the compliance time that provides an equivalent level of safety may be approved by the Manager, Small Airplane Directorate, FAA, 1201 Walnut, suite 900, Kansas City, Missouri 64106. The request shall be forwarded through an appropriate FAA Maintenance Inspector, who may add comments and then send it to the Manager, Small Airplane Directorate.

Note 3: Information concerning the existence of approved alternative methods of compliance with this AD, if any, may be obtained from the Small Airplane Directorate.

(d) Questions or technical information related to Diamond Aircraft Industries Service Bulletin No. 20-32, dated April 5, 1996, should be directed to Diamond Aircraft Industries G.m.b.H., N.A. Otto-Strabe 5, A-2700, Wiener Neustadt, Austria. This service information may be examined at the FAA, Central Region, Office of the Regional Counsel, Room 1558, 601 E. 12th Street, Kansas City, Missouri.

Note 4: The subject of this AD is addressed in Austrian AD No. 86, dated May 29, 1996.

(e) This amendment (39-10315) becomes effective on March 24, 1998.

Issued in Kansas City, Missouri, on February 2, 1998.

Carolanne L. Cabrini,
Acting Manager, Small Airplane Directorate,
Aircraft Certification Service.

[FR Doc. 98-3225 Filed 2-9-98; 8:45 am]

BILLING CODE 4910-13-U

DEPARTMENT OF TRANSPORTATION

Federal Aviation Administration

14 CFR Part 39

[Docket No. 97-CE-93-AD; Amendment 39-10314; AD 98-04-01]

RIN 2120-AA64

Airworthiness Directives; EXTRA Flugzeugbau GmbH Model EA-300/S Airplanes

AGENCY: Federal Aviation Administration, DOT.

ACTION: Final rule.

SUMMARY: This amendment adopts a new airworthiness directive (AD) that applies to certain EXTRA Flugzeugbau GmbH Model EA-300/S airplanes. This AD requires modifying the canopy latches or replacing the canopy latches with parts of improved design. This AD is the result of mandatory continuing airworthiness information (MCAI) issued by the airworthiness authority for Germany. The actions specified by this AD are intended to prevent failure of the canopy while the airplane is in flight because of cracked canopy latches, which could result in loss of the canopy and possible loss of control of the airplane.

DATES: Effective March 24, 1998.

The incorporation by reference of certain publications listed in the regulations is approved by the Director of the Federal Register as of March 24, 1998.

ADDRESSES: Service information that applies to this AD may be obtained from EXTRA Flugzeugbau GmbH, Flugplatz Dinslaken, 46569 Hünxe, Germany. This information may also be examined at the Federal Aviation Administration (FAA), Central Region, Office of the Regional Counsel, Attention: Rules Docket No. 97-CE-93-AD, Room 1558, 601 E. 12th Street, Kansas City, Missouri 64106; or at the Office of the Federal Register, 800 North Capitol Street, NW, suite 700, Washington, DC.

FOR FURTHER INFORMATION CONTACT: Mr. Karl Schletzbaum, Aerospace Engineer, FAA, Small Airplane Directorate, 1201 Walnut Street, suite 900, Kansas City, Missouri 64106; telephone: (816) 426-6934; facsimile: (816) 426-2169.

SUPPLEMENTARY INFORMATION:

Events Leading to the Issuance of This AD

A proposal to amend part 39 of the Federal Aviation Regulations (14 CFR part 39) to include an AD that would apply to certain EXTRA Flugzeugbau GmbH Model EA-300/S airplanes was

published in the *Federal Register* as a notice of proposed rulemaking (NPRM) on November 5, 1997 (62 FR 59827). The NPRM proposed to require modifying the canopy latches or replacing the canopy latches with parts of improved design, part number (P/N) PC-23303.8P1 for both front latches and the rear right; and P/N PC-23303.8P2 for the rear left. Accomplishment of the proposed actions would be in accordance with EXTRA Service Bulletin No. 300-3-94, dated August 3, 1994.

The NPRM was the result of mandatory continuing airworthiness information (MCAI) issued by the airworthiness authority for Germany.

Interested persons have been afforded an opportunity to participate in the making of this amendment. No comments were received on the proposed rule or the FAA's determination of the cost to the public.

The FAA's Determination

After careful review of all available information related to the subject presented above, the FAA has determined that air safety and the public interest require the adoption of the rule as proposed except for minor editorial corrections. The FAA has determined that these minor corrections will not change the meaning of the AD and will not add any additional burden upon the public than was already proposed.

Cost Impact

The FAA estimates that 25 airplanes in the U.S. registry will be affected by this AD, that it will take approximately 3 workhours per airplane to accomplish the modifications or replacements, and that the average labor rate is approximately \$60 an hour. Parts cost approximately \$100 per airplane. Based on these figures, the total cost impact of this AD on U.S. operators is estimated to be \$7,000, or \$280 per airplane.

Differences Between the German AD, the Service Bulletin, and This AD

German AD 94-258, dated August 25, 1994, and EXTRA Service Bulletin No. 300-3-94, dated August 3, 1994, both give the owners/operators of certain Model EA-300/S airplanes the option of (1) repetitively inspecting the canopy latches until cracks are found, and then modifying or replacing (with parts of improved design) any cracked latches; or (2) immediately modifying the existing latches or replacing the latches with parts of improved design.

The FAA's policy is to provide corrective action that will eliminate the need for repetitive inspections. The

FAA has determined that long-term operational safety will be better assured by design changes that remove the source of the problem, rather than by repetitive inspections or other special procedures.

Because the modification or replacement (with parts of improved design) of the canopy latches eliminates the need for repetitive inspections, this AD differs from the service bulletin and the German AD in that it will mandate either modification or replacement of the canopy latches regardless of condition.

Regulatory Impact

The regulations adopted herein will not have substantial direct effects on the States, on the relationship between the national government and the States, or on the distribution of power and responsibilities among the various levels of government. Therefore, in accordance with Executive Order 12612, it is determined that this final rule does not have sufficient federalism implications to warrant the preparation of a Federalism Assessment.

For the reasons discussed above, I certify that this action (1) is not a "significant regulatory action" under Executive Order 12866; (2) is not a "significant rule" under DOT Regulatory Policies and Procedures (44 FR 11034, February 26, 1979); and (3) will not have a significant economic impact, positive or negative, on a substantial number of small entities under the criteria of the Regulatory Flexibility Act. A copy of the final evaluation prepared for this action is contained in the Rules Docket. A copy of it may be obtained by contacting the Rules Docket at the location provided under the caption **ADDRESSES**.

List of Subjects in 14 CFR Part 39

Air transportation, Aircraft, Aviation safety, Incorporation by reference, Safety.

Adoption of the Amendment

Accordingly, pursuant to the authority delegated to me by the Administrator, the Federal Aviation Administration amends part 39 of the Federal Aviation Regulations (14 CFR part 39) as follows:

PART 39—AIRWORTHINESS DIRECTIVES

1. The authority citation for part 39 continues to read as follows:

Authority: 49 U.S.C. 106(g), 40113, 44701.

§ 39.13 [Amended]

2. Section 39.13 is amended by adding a new airworthiness directive (AD) to read as follows:

98-04-01 Extra Flugzeugbau GMBH:

Amendment 39-10314; Docket No. 97-CE-93-AD.

Applicability: Models EA-300/S airplanes, serial numbers 01 through 24, certificated in any category.

Note 1: This AD applies to each airplane identified in the preceding applicability provision, regardless of whether it has been modified, altered, or repaired in the area subject to the requirements of this AD. For airplanes that have been modified, altered, or repaired so that the performance of the requirements of this AD is affected, the owner/operator must request approval for an alternative method of compliance in accordance with paragraph (c) of this AD. The request should include an assessment of the effect of the modification, alteration, or repair on the unsafe condition addressed by this AD; and, if the unsafe condition has not been eliminated, the request should include specific proposed actions to address it.

Compliance: Required within the next 100 hours time-in-service (TIS) after the effective date of this AD, unless already accomplished.

To prevent failure of the canopy while the airplane is in flight because of cracked canopy latches, which could result in loss of the canopy and possible loss of control of the airplane, accomplish the following:

(a) Modify all canopy latches or replace all canopy latches with parts of improved design, part number (P/N) PC-23303.8P1 for both front latches and the rear right; and P/N PC-23303.8P2 for the rear left. Accomplish the modifications or replacements in accordance with the *Instructions* section of EXTRA Service Bulletin No. 300-3-94, dated August 3, 1994.

(b) Special flight permits may be issued in accordance with sections 21.197 and 21.199 of the Federal Aviation Regulations (14 CFR 21.197 and 21.199) to operate the airplane to a location where the requirements of this AD can be accomplished.

(c) An alternative method of compliance or adjustment of the compliance time that provides an equivalent level of safety may be approved by the Manager, Small Airplane Directorate, FAA, 1201 Walnut, suite 900, Kansas City, Missouri 64106. The request shall be forwarded through an appropriate FAA Maintenance Inspector, who may add comments and then send it to the Manager, Small Airplane Directorate.

Note 2: Information concerning the existence of approved alternative methods of compliance with this AD, if any, may be obtained from the Small Airplane Directorate.

(d) Questions or technical information related to EXTRA Service Bulletin No. 300-3-94, dated August 3, 1994, should be directed to EXTRA Flugzeugbau GmbH, Flugplatz Dinslaken, 46569 Hünxe, Germany. This service information may be examined at the FAA, Central Region, Office of the Regional Counsel, Room 1558, 601 E. 12th Street, Kansas City, Missouri.

(e) The modifications or replacements required by this AD shall be done in accordance with EXTRA Service Bulletin No. 300-3-94, dated August 3, 1994. This incorporation by reference was approved by the Director of the Federal Register in accordance with 5 U.S.C. 552(a) and 1 CFR part 51. Copies may be obtained from EXTRA Flugzeugbau GmbH, Flugplatz Dinslaken, 46569 Hünxe, Germany. Copies may be inspected at the FAA, Central Region, Office of the Regional Counsel, Room 1558, 601 E. 12th Street, Kansas City, Missouri, or at the Office of the Federal Register, 800 North Capitol Street, NW, suite 700, Washington, DC.

Note 3: The subject of this AD is addressed in German AD 94-258, dated August 25, 1994.

(f) This amendment (39-10314) becomes effective on March 24, 1998.

Issued in Kansas City, Missouri, on February 2, 1998.

Carolanne L. Cabrini,

Acting Manager, Small Airplane Directorate, Aircraft Certification Service.

[FR Doc. 98-3226 Filed 2-9-98; 8:45 am]

BILLING CODE 4910-13-U

DEPARTMENT OF TRANSPORTATION**Federal Aviation Administration****14 CFR Part 39**

[Docket No. 97-CE-43-AD; Amendment 39-10317; AD 98-04-04]

RIN 2120-AA64

Airworthiness Directives; SOCATA-Groupe AEROSPATIALE Model TBM 700 Airplanes

AGENCY: Federal Aviation Administration, DOT.

ACTION: Final rule.

SUMMARY: This amendment adopts a new airworthiness directive (AD) that applies to certain SOCATA-Groupe AEROSPATIALE (Socata) Model TBM 700 airplanes. This AD requires replacing the starter generator mounting adapter with a part of improved design. This AD is the result of mandatory continuing airworthiness information (MCAI) issued by the airworthiness authority for France. The actions specified by this AD are intended to prevent loss of the starter generator caused by failure of the starter generator mounting adapter, which could result in loss of electrical power.

DATES: Effective March 24, 1998.

The incorporation by reference of certain publications listed in the regulations is approved by the Director of the Federal Register as of March 24, 1998.

ADDRESSES: Service information that applies to this AD may be obtained from

SOCATA-Groupe AEROSPATIALE, Socata Product Support, Aeroport Tarbes-Ossun-Lourdes, B P 930, 65009 Tarbes Cedex, France; telephone: 62.41.74.26; facsimile: 62.41.74.32; or the Product Support Manager, SOCATA-Groupe AEROSPATIALE, North Perry Airport, 7501 Pembroke Road, Pembroke Pines, Florida 33023; telephone: (954) 964-6877; facsimile: (954) 964-1668. This information may also be examined at the Federal Aviation Administration (FAA), Central Region, Office of the Regional Counsel, Attention: Rules Docket No. 97-CE-43-AD, Room 1558, 601 E. 12th Street, Kansas City, Missouri 64106; or at the Office of the Federal Register, 800 North Capitol Street, NW, suite 700, Washington, DC.

FOR FURTHER INFORMATION CONTACT: Mr. Karl Schletzbaum, Aerospace Engineer, FAA, Small Airplane Directorate, 1201 Walnut Street, suite 900, Kansas City, Missouri 64106; telephone: (816) 426-6934; facsimile: (816) 426-2169.

SUPPLEMENTARY INFORMATION:**Events Leading to the Issuance of This AD**

A proposal to amend part 39 of the Federal Aviation Regulations (14 CFR part 39) to include an AD that would apply to certain Socata Model TBM 700 airplanes was published in the *Federal Register* as a notice of proposed rulemaking (NPRM) on November 7, 1997 (62 FR 60184). The NPRM proposed to require replacing the starter generator mounting adapter with a part of improved design by incorporating Socata Kit No. OPT70K0058-24. Accomplishment of the proposed action as specified in the NPRM would be required in accordance with Socata Service Bulletin No. SB 70-072, dated January 1996.

The NPRM was the result of mandatory continuing airworthiness information (MCAI) issued by the airworthiness authority for France.

Interested persons have been afforded an opportunity to participate in the making of this amendment. No comments were received on the proposed rule or the FAA's determination of the cost to the public.

The FAA's Determination

After careful review of all available information related to the subject presented above, the FAA has determined that air safety and the public interest require the adoption of the rule as proposed except for minor editorial corrections. The FAA has determined that these minor corrections will not change the meaning of the AD

and will not add any additional burden upon the public than was already proposed.

Cost Impact

The FAA estimates that 55 airplanes in the U.S. registry will be affected by this AD.

This replacement will take approximately 2 workhours per airplane to accomplish, at an average labor rate of approximately \$60 an hour. Parts to accomplish this AD will be provided by the manufacturer at no cost to the owners/operators of the affected airplanes. Based on these figures, the total cost impact of this AD on U.S. operators is estimated to be \$6,600, or \$120 per airplane.

Differences Between the French AD, the Service Bulletin, and This AD

French AD 95-242(B)R1, dated February 28, 1996, and Socata Service Bulletin No. SB 70-072, dated January 1996, both give the owners/operators of certain Model TBM 700 airplanes the option of replacing the starter generator mounting adapter immediately or inspecting this adapter for cracks every 25 hours time-in-service (TIS) up to 100 hours TIS, at which time the replacement is mandatory. This allows the owners/operators the option of having their airplanes inspected up to three times before mandatory replacement, provided no cracked adapters were found, which, if found cracked, would require immediate replacement.

The FAA has determined that, since the parts for the replacement are free; the parts are available; and the action takes less than 2 workhours to accomplish, 25 hours TIS will be adequate time to incorporate the replacement. This AD will require replacing the starter generator mounting adapter within 25 hours TIS, and will not allow the option of repetitively inspecting every 25 hours TIS up to 100 hours TIS.

Regulatory Impact

The regulations adopted herein will not have substantial direct effects on the States, on the relationship between the national government and the States, or on the distribution of power and responsibilities among the various levels of government. Therefore, in accordance with Executive Order 12612, it is determined that this final rule does not have sufficient federalism implications to warrant the preparation of a Federalism Assessment.

For the reasons discussed above, I certify that this action (1) is not a "significant regulatory action" under

Executive Order 12866; (2) is not a "significant rule" under DOT Regulatory Policies and Procedures (44 FR 11034, February 26, 1979); and (3) will not have a significant economic impact, positive or negative, on a substantial number of small entities under the criteria of the Regulatory Flexibility Act. A copy of the final evaluation prepared for this action is contained in the Rules Docket. A copy of it may be obtained by contacting the Rules Docket at the location provided under the caption ADDRESSES.

List of Subjects in 14 CFR Part 39

Air transportation, Aircraft, Aviation safety, Incorporation by reference, Safety.

Adoption of the Amendment

Accordingly, pursuant to the authority delegated to me by the Administrator, the Federal Aviation Administration amends part 39 of the Federal Aviation Regulations (14 CFR part 39) as follows:

PART 39—AIRWORTHINESS DIRECTIVES

1. The authority citation for part 39 continues to read as follows:

Authority: 49 U.S.C. 106(g), 40113, 44701.

§ 39.13 [Amended]

2. Section 39.13 is amended by adding a new airworthiness directive (AD) to read as follows:

98-04-04 Socata-Groupe Aerospatiale:
Amendment 39-10317; Docket No. 97-CE-43-AD.

Applicability: Model TBM 700 airplanes, serial numbers 1 through 109, certificated in any category.

Note 1: This AD applies to each airplane identified in the preceding applicability provision, regardless of whether it has been modified, altered, or repaired in the area subject to the requirements of this AD. For airplanes that have been modified, altered, or repaired so that the performance of the requirements of this AD is affected, the owner/operator must request approval for an alternative method of compliance in accordance with paragraph (c) of this AD. The request should include an assessment of the effect of the modification, alteration, or repair on the unsafe condition addressed by this AD; and, if the unsafe condition has not been eliminated, the request should include specific proposed actions to address it.

Compliance: Required within the next 25 hours time-in-service (TIS) after the effective date of this AD, unless already accomplished.

To prevent loss of the starter generator caused by failure of the starter generator mounting adapter, which could result in loss of electrical power, accomplish the following:

(a) Replace the starter generator mounting adapter with a part of improved design by

incorporating Socata Kit No. OPT70K0058-24. This replacement shall be accomplished in accordance with the ACCOMPLISHMENT INSTRUCTIONS section of Socata Service Bulletin No. SB 70-072, dated January 1996.

(b) Special flight permits may be issued in accordance with sections 21.197 and 21.199 of the Federal Aviation Regulations (14 CFR 21.197 and 21.199) to operate the airplane to a location where the requirements of this AD can be accomplished.

(c) An alternative method of compliance or adjustment of the compliance time that provides an equivalent level of safety may be approved by the Manager, Small Airplane Directorate, FAA, 1201 Walnut, suite 900, Kansas City, Missouri 64106. The request shall be forwarded through an appropriate FAA Maintenance Inspector, who may add comments and then send it to the Manager, Small Airplane Directorate.

Note 2: Information concerning the existence of approved alternative methods of compliance with this AD, if any, may be obtained from the Small Airplane Directorate.

(d) Questions or technical information related to Socata Service Bulletin No. SB 70-072, dated January 1996, should be directed to SOCATA-Groupe Aerospatiale, Socata Product Support, Aeroport Tarbes-Ossun-Lourdes, B P 930, 65009 Tarbes Cedex, France; or Perry Airport, 7501 Pembroke Road, Pembroke Pines, Florida 33023; telephone: (954) 964-6877; facsimile: (954) 964-1688. This service information may be examined at the FAA, Central Region, Office of the Regional Counsel, Room 1558, 601 E. 12th Street, Kansas City, Missouri.

(e) The replacement required by this AD shall be done in accordance with ACCOMPLISHMENT INSTRUCTIONS section of Socata Service Bulletin No. SB 70-072, dated January 1996. This incorporation by reference was approved by the Director of the Federal Register in accordance with 5 U.S.C. 552(a) and 1 CFR part 51. Copies may be obtained from SOCATA-Groupe Aerospatiale, Socata Product Support, Aeroport Tarbes-Ossun-Lourdes, B P 930, 65009 Tarbes Cedex, France; or Perry Airport, 7501 Pembroke Road, Pembroke Pines, Florida 33023. Copies may be inspected at the FAA, Central Region, Office of the Regional Counsel, Room 1558, 601 E. 12th Street, Kansas City, Missouri, or at the Office of the Federal Register, 800 North Capitol Street, NW, suite 700, Washington, DC.

Note 3: The subject of this AD is addressed in French AD 95-242(B)R1, dated February 28, 1996.

(f) This amendment (39-10317) becomes effective on March 24, 1998.

Issued in Kansas City, Missouri, on February 2, 1998.

Carolanne L. Cabrini,
Acting Manager, Small Airplane Directorate,
Aircraft Certification Service.

[FR Doc. 98-2331 Filed 2-9-98; 8:45 am]

BILLING CODE 4910-13-P

DEPARTMENT OF TRANSPORTATION

Federal Aviation Administration

14 CFR Part 39

[Docket No. 97-CE-77-AD; Amendment 39-10316; AD 98-04-03]

RIN 2120-AA64

Airworthiness Directives; SOCATA-Groupe AEROSPATIALE Models TB9, TB10, TB20, TB21, and TB200 Airplanes

AGENCY: Federal Aviation Administration, DOT.

ACTION: Final rule.

SUMMARY: This amendment adopts a new airworthiness directive (AD) that applies to certain Socata-Groupe Aerospatiale (Socata) Models TB9, TB10, TB20, TB21, and TB200 airplanes. This AD requires inspecting the bolts and spacers of the upper attachments of the front belts for cracks, dents, etc. (damage); replacing any damaged bolts or spacers; incorporating a front belts upper attachment reinforcement kit; and reconditioning the belts. This AD is the result of mandatory continuing airworthiness information (MCAI) issued by the airworthiness authority for France. The actions specified by this AD are intended to prevent failure of the upper seat belt attachment caused by excessive loads on the upper attachment of the belt, which could result in bodily injury to the occupants during landing.

DATES: Effective March 24, 1998.

The incorporation by reference of certain publications listed in the regulations is approved by the Director of the Federal Register as of March 24, 1998.

ADDRESSES: Service information that applies to this AD may be obtained from Socata-Groupe Aerospatiale, Socata Product Support, Aeroport Tarbes-Ossun-Lourdes, B P 930, 65009 Tarbes Cedex, France; telephone: 62.41.74.26; facsimile: 62.41.74.32; or the Product Support Manager, Socata-Groupe Aerospatiale, North Perry Airport, 7501 Pembroke Road, Pembroke Pines, Florida 33023; telephone: (954) 964-6877; facsimile: (954) 964-1668. This information may also be examined at the Federal Aviation Administration (FAA), Central Region, Office of the Regional Counsel, Attention: Rules Docket No. 97-CE-77-AD, Room 1558, 601 E. 12th Street, Kansas City, Missouri 64106; or at the Office of the Federal Register, 800 North Capitol Street, NW, suite 700, Washington, DC.

FOR FURTHER INFORMATION CONTACT: Mr. Karl Schletzbaum, Aerospace Engineer, FAA, Small Airplane Directorate, 1201 Walnut Street, suite 900, Kansas City, Missouri 64106; telephone: (816) 426-6934; facsimile: (816) 426-2169.

SUPPLEMENTARY INFORMATION:

Events Leading to the Issuance of This AD

A proposal to amend part 39 of the Federal Aviation Regulations (14 CFR part 39) to include an AD that would apply to certain Socata Models TB9, TB10, TB20, TB21, and TB200 airplanes was published in the *Federal Register* as a notice of proposed rulemaking (NPRM) on November 7, 1997 (62 FR 60189). The NPRM proposed to require inspecting the bolts and spacers of the upper attachments of the front belts for cracks, dents, etc. (damage); replacing any damaged bolts or spacers; incorporating a front belts upper attachment reinforcement kit; and reconditioning the belts.

Accomplishment of the proposed action as specified in the NPRM would be in accordance with Socata Service Bulletin No. SB 10-103 and Socata Service Bulletin No. SB 10-104, both dated June 1996.

The NPRM was the result of mandatory continuing airworthiness information (MCAI) issued by the airworthiness authority for France.

Interested persons have been afforded an opportunity to participate in the making of this amendment. No comments were received on the proposed rule or the FAA's determination of the cost to the public.

The FAA's Determination

After careful review of all available information related to the subject presented above, the FAA has determined that air safety and the public interest require the adoption of the rule as proposed except for minor editorial corrections. The FAA has determined that these minor corrections will not change the meaning of the AD and will not add any additional burden upon the public than was already proposed.

Cost Impact

The FAA estimates that 320 airplanes in the U.S. registry will be affected by this AD.

Accomplishing this replacement will take approximately 3 workhours per airplane, at an average labor rate of approximately \$60 an hour. Parts to accomplish this AD cost approximately \$300. Based on these figures, the total cost impact of this AD on U.S. operators

is estimated to be \$153,600, or \$480 per airplane.

Regulatory Impact

The regulations adopted herein will not have substantial direct effects on the States, on the relationship between the national government and the States, or on the distribution of power and responsibilities among the various levels of government. Therefore, in accordance with Executive Order 12612, it is determined that this final rule does not have sufficient federalism implications to warrant the preparation of a Federalism Assessment.

For the reasons discussed above, I certify that this action (1) is not a "significant regulatory action" under Executive Order 12866; (2) is not a "significant rule" under DOT Regulatory Policies and Procedures (44 FR 11034, February 26, 1979); and (3) will not have a significant economic impact, positive or negative, on a substantial number of small entities under the criteria of the Regulatory Flexibility Act. A copy of the final evaluation prepared for this action is contained in the Rules Docket. A copy of it may be obtained by contacting the Rules Docket at the location provided under the caption **ADDRESSES**.

List of Subjects in 14 CFR Part 39

Air transportation, Aircraft, Aviation safety, Incorporation by reference, Safety.

Adoption of the Amendment

Accordingly, pursuant to the authority delegated to me by the Administrator, the Federal Aviation Administration amends part 39 of the Federal Aviation Regulations (14 CFR part 39) as follows:

PART 39—AIRWORTHINESS DIRECTIVES

1. The authority citation for part 39 continues to read as follows:

Authority: 49 U.S.C. 106(g), 40113, 44701.

§ 39.13 [Amended]

2. Section 39.13 is amended by adding a new airworthiness directive (AD) to read as follows:

98-04-03 Socata—Groupe Aerospatiale:
Amendment 39-10316; Docket No. 97-CE-77-AD.

Applicability: Models TB9, TB10, TB20, TB21, and TB200 airplanes, serial numbers 1 through 1701; 1707 to 1750; 1758 to 1763; 1767, 1768, and 1769, certificated in any category.

Note 1: This AD applies to each airplane identified in the preceding applicability provision, regardless of whether it has been modified, altered, or repaired in the area

subject to the requirements of this AD. For airplanes that have been modified, altered, or repaired so that the performance of the requirements of this AD is affected, the owner/operator must request approval for an alternative method of compliance in accordance with paragraph (e) of this AD. The request should include an assessment of the effect of the modification, alteration, or repair on the unsafe condition addressed by this AD; and, if the unsafe condition has not been eliminated, the request should include specific proposed actions to address it.

Compliance: Required as indicated in the body of this AD, unless already accomplished.

To prevent failure of the upper seat belt attachment caused by excessive loads on the upper attachment of the belt, which could result in bodily injury to the occupants during landing, accomplish the following:

(a) Within the next 50 hours time-in-service (TIS) after the effective date of this AD, inspect the bolts and spacers of the upper attachments of the front belts for cracks, dents, etc. (damage), in accordance with the ACCOMPLISHMENT INSTRUCTIONS section of one of the following service bulletins, as applicable:

(1) Socata Service Bulletin No. SB 10-103, dated June 1996, which applies to Socata Models TB10, TB20, TB21, and TB200 airplanes, and Model TB9 airplanes equipped with upholstery on the upper duct posts.

(2) Socata Service Bulletin No. SB 10-104, dated June 1996, which applies to Socata Model TB9 airplanes not equipped with upholstery on the upper duct posts.

(b) Prior to further flight after the inspection required by paragraph (a) of this AD, replace any damaged bolts or spacers found during the inspection required by paragraph (a) of this AD.

(c) Within the next 50 hours TIS after the effective date of this AD, incorporate either front belts upper attachment reinforcement kit No. OPT10 921000 or OPT10 920900 and recondition the belts in accordance with the ACCOMPLISHMENT INSTRUCTIONS section of the applicable service bulletin referenced in paragraph (a)(1) or (a)(2) of this AD.

(d) Special flight permits may be issued in accordance with sections 21.197 and 21.199 of the Federal Aviation Regulations (14 CFR 21.197 and 21.199) to operate the airplane to a location where the requirements of this AD can be accomplished.

(e) An alternative method of compliance or adjustment of the compliance time that provides an equivalent level of safety may be approved by the Manager, Small Airplane Directorate, FAA, 1201 Walnut, suite 900, Kansas City, Missouri 64106. The request shall be forwarded through an appropriate FAA Maintenance Inspector, who may add comments and then send it to the Manager, Small Airplane Directorate.

Note 2: Information concerning the existence of approved alternative methods of compliance with this AD, if any, may be obtained from the Small Airplane Directorate.

(f) Questions or technical information related to Socata Service Bulletin No. SB 10-103 and Service Bulletin No. SB 10-104, both

dated June 1996, should be directed to SOCATA—Groupe AEROSPATIALE, Socata Product Support, Aeroport Tarbes-Ossun-Lourdes, B P 930, 65009 Tarbes Cedex, France; or Perry Airport, 7501 Pembroke Road, Pembroke Pines, Florida 33023; telephone: (954) 964-6877; facsimile: (954) 964-1688. This service information may be examined at the FAA, Central Region, Office of the Regional Counsel, Room 1558, 601 E. 12th Street, Kansas City, Missouri.

(g) The inspection and replacement required by this AD shall be done in accordance with Socata Service Bulletin No. SB 10-103, dated June 1996, or Socata Service Bulletin No. SB 10-104, dated June 1996. This incorporation by reference was approved by the Director of the Federal Register in accordance with 5 U.S.C. 552(a) and 1 CFR part 51. Copies may be obtained from SOCATA—Groupe AEROSPATIALE, Socata Product Support, Aeroport Tarbes-Ossun-Lourdes, B P 930, 65009 Tarbes Cedex, France; or Perry Airport, 7501 Pembroke Road, Pembroke Pines, Florida 33023. Copies may be inspected at the FAA, Central Region, Office of the Regional Counsel, Room 1558, 601 E. 12th Street, Kansas City, Missouri, or at the Office of the Federal Register, 800 North Capitol Street, NW, suite 700, Washington, DC.

Note 3: The subject of this AD is addressed in French AD 96-142(A) and French AD 96-143(A), both dated July 17, 1996.

(h) This amendment (39-10316) becomes effective on March 24, 1998.

Issued in Kansas City, Missouri, on February 2, 1998.

Carolanne L. Cabrini,

Acting Manager, Small Airplane Directorate, Aircraft Certification Service.

[FR Doc. 98-3230 Filed 2-9-98; 8:45 am]

BILLING CODE 4910-13-U

DEPARTMENT OF TRANSPORTATION

Federal Aviation Administration

14 CFR Part 39

[Docket No. 98-NM-12-AD; Amendment 39-10320; AD 98-04-07]

RIN 2120-AA64

Airworthiness Directives; McDonnell Douglas Model DC-9 and DC-9-80 Series Airplanes, and C-9 (Military) Series Airplanes

AGENCY: Federal Aviation Administration, DOT.

ACTION: Final rule; request for comments.

SUMMARY: This amendment supersedes an existing airworthiness directive (AD), applicable to certain McDonnell Douglas Model DC-9 and C-9 (military) series airplanes, that currently requires eddy current or dye penetrant inspection for cracks in the upper fuselage skin in the area of the aft

pressure bulkhead tee. This amendment requires new improved repetitive inspections and follow-on actions, and expands the applicability of the existing AD to include additional airplanes. This amendment is prompted by additional reports of fatigue cracking and improperly seated attachments in the upper fuselage skin in the area of the aft pressure bulkhead tee. The actions specified in this AD are intended to detect and correct such fatigue cracking, which could result in rapid decompression of the fuselage and consequent reduced structural integrity of the airplane.

DATES: Effective February 25, 1998.

The incorporation by reference of certain publications listed in the regulations is approved by the Director of the Federal Register as of February 25, 1998.

Comments for inclusion in the Rules Docket must be received on or before April 13, 1998.

ADDRESSES: Submit comments in triplicate to the Federal Aviation Administration (FAA), Transport Airplane Directorate, ANM-114, Attention: Rules Docket No. 98-NM-12-AD, 1601 Lind Avenue, SW., Renton, Washington 98055-4056.

The service information referenced in this AD may be obtained from The Boeing Company, Douglas Products Division, 3855 Lakewood Boulevard, Long Beach, California 90846, Attention: Technical Publications Business Administration, Dept. C1-L51 (2-60). This information may be examined at the FAA, Transport Airplane Directorate, 1601 Lind Avenue, SW., Renton, Washington; or at the FAA, Los Angeles Aircraft Certification Office, 3960 Paramount Boulevard, Lakewood, California; or at the Office of the Federal Register, 800 North Capitol Street, NW., suite 700, Washington, DC.

FOR FURTHER INFORMATION CONTACT: Wahib Mina, Aerospace Engineer, Airframe Branch, ANM-120L, FAA, Los Angeles Aircraft Certification Office, 3960 Paramount Boulevard, Lakewood, California 90712; telephone (562) 627-5324; fax (562) 627-5210.

SUPPLEMENTARY INFORMATION: On May 19, 1982, the FAA issued AD 81-26-03 R1, amendment 39-4394 (47 FR 23697, June 1, 1982), applicable to certain McDonnell Douglas Model DC-9 and C-9 (military) series airplanes, to require eddy current or dye penetrant inspection for cracks in the upper fuselage skin in the area of the aft pressure bulkhead tee. That action was prompted by reports of fatigue cracking in the upper skin and improperly seated

attachments in the upper skin splice area at the fuselage aft pressure bulkhead tee between longerons 14 left and 14 right. The actions required by that AD are intended to prevent such fatigue cracking, which could result in structural failure of the fuselage shell, and consequent rapid decompression of the airplane.

Actions Since Issuance of Previous Rule

Since the issuance of that AD, the FAA has received reports of additional fatigue cracking and improperly seated attachments in the subject area on McDonnell Douglas Model DC-9 series airplanes. These airplanes had accumulated between 57,485 and 67,755 total flight cycles. The FAA has determined that accomplishment of the inspections required by AD 81-26-03 R1 does not adequately preclude fatigue cracking of the upper skin splice on the aft pressure bulkhead of the fuselage. Such fatigue cracking, if not detected and corrected in a timely manner, could result in rapid decompression of the fuselage and consequent reduced structural integrity of the airplane.

The subject area on certain McDonnell Douglas Model DC-9-80 and C-9 (military) series airplanes is identical to that on the affected Model DC-9 series airplanes. Therefore, all of these airplanes may be subject to the same unsafe condition.

Explanation of Relevant Service Information

Subsequent to the finding of this new cracking, the manufacturer issued, and the FAA reviewed and approved, McDonnell Douglas Alert Service Bulletin DC9-53A147, Revision 05, dated November 24, 1997, including Service Sketch 3145B and Service Sketch 3174C (both undated). The revised alert service bulletin describes new, improved procedures for repetitive high frequency eddy current (HFEC) inspections to detect cracks of the upper skin splice area at the tee cap on the aft fuselage pressure bulkhead between longerons 14 left and 14 right; and installation of an interim repair, or replacement of failed fasteners with new fasteners, if necessary. The revised alert service bulletin also provides for an optional terminating permanent repair, which eliminates the need for the repetitive inspections. In addition, the revised alert service bulletin expands the effectivity listing to include additional airplanes that are subject to the addressed unsafe condition.

Explanation of Requirements of Rule

Since an unsafe condition has been identified that is likely to exist or

develop on other airplanes of this same type design, this AD supersedes AD 81-26-03 R1. This AD requires new, improved repetitive HFEC inspections to detect cracks in the upper skin splice area at the tee cap on the aft fuselage pressure bulkhead between longerons 14 left and 14 right; and installation of an interim repair, or replacement of failed fasteners with new fasteners, if necessary. The AD also provides for an optional terminating permanent repair, which constitutes terminating action for the repetitive inspection requirements. In addition, the AD expands the applicability of the existing AD to include additional airplanes. The actions would be required to be accomplished in accordance with the alert service bulletin described previously.

Differences Between the AD and the Relevant Service Information

Operators should note that this AD differs from the referenced alert service bulletin in that it requires an initial visual inspection of the fuselage upper skin splice at the aft pressure bulkhead between longerons 14 left and 14 right to determine if an internal production titanium doubler has been installed. The referenced alert service bulletin describes procedures for inspection of airplanes on which the doubler has been installed; however, it does not describe procedures for such inspection of airplanes on which the doubler has *not* been installed.

The FAA has received reports of widespread fatigue-related cracking on airplanes that had been inspected previously in accordance with AD 81-26-03 R1, and on which an internal production titanium doubler had not been installed. In light of this, the FAA finds that an initial one-time visual inspection is necessary to determine if a doubler has been installed.

In addition, for airplanes on which the subject doubler has not been installed, the AD would require a visual inspection of the subject area to determine if an interim or permanent repair has been installed; and follow-on actions, if necessary. (These follow-on actions include repetitive HFEC inspections, replacement of failed fasteners, and accomplishment of an interim repair.)

Determination of Rule's Effective Date

Since a situation exists that requires the immediate adoption of this regulation, it is found that notice and opportunity for prior public comment hereon are impracticable, and that good cause exists for making this amendment effective in less than 30 days.

Comments Invited

Although this action is in the form of a final rule that involves requirements affecting flight safety and, thus, was not preceded by notice and an opportunity for public comment, comments are invited on this rule. Interested persons are invited to comment on this rule by submitting such written data, views, or arguments as they may desire. Communications shall identify the Rules Docket number and be submitted in triplicate to the address specified under the caption **ADDRESSES**. All communications received on or before the closing date for comments will be considered, and this rule may be amended in light of the comments received. Factual information that supports the commenter's ideas and suggestions is extremely helpful in evaluating the effectiveness of the AD action and determining whether additional rulemaking action would be needed.

Comments are specifically invited on the overall regulatory, economic, environmental, and energy aspects of the rule that might suggest a need to modify the rule. All comments submitted will be available, both before and after the closing date for comments, in the Rules Docket for examination by interested persons. A report that summarizes each FAA-public contact concerned with the substance of this AD will be filed in the Rules Docket.

Commenters wishing the FAA to acknowledge receipt of their comments submitted in response to this rule must submit a self-addressed, stamped postcard on which the following statement is made: "Comments to Docket Number 98-NM-12-AD." The postcard will be date stamped and returned to the commenter.

Regulatory Impact

The regulations adopted herein will not have substantial direct effects on the States, on the relationship between the national government and the States, or on the distribution of power and responsibilities among the various levels of government. Therefore, in accordance with Executive Order 12612, it is determined that this final rule does not have sufficient federalism implications to warrant the preparation of a Federalism Assessment.

The FAA has determined that this regulation is an emergency regulation that must be issued immediately to correct an unsafe condition in aircraft, and that it is not a "significant regulatory action" under Executive Order 12866. It has been determined further that this action involves an

emergency regulation under DOT Regulatory Policies and Procedures (44 FR 11034, February 26, 1979). If it is determined that this emergency regulation otherwise would be significant under DOT Regulatory Policies and Procedures, a final regulatory evaluation will be prepared and placed in the Rules Docket. A copy of it, if filed, may be obtained from the Rules Docket at the location provided under the caption ADDRESSES.

List of Subjects in 14 CFR Part 39

Air transportation, Aircraft, Aviation safety, Incorporation by reference, Safety.

Adoption of the Amendment

Accordingly, pursuant to the authority delegated to me by the Administrator, the Federal Aviation Administration amends part 39 of the Federal Aviation Regulations (14 CFR part 39) as follows:

PART 39—AIRWORTHINESS DIRECTIVES

1. The authority citation for part 39 continues to read as follows:

Authority: 49 U.S.C. 106(g), 40113, 44701.

§ 39.13 [Amended]

2. Section 39.13 is amended by removing amendment 39-4394 (47 FR 23697, June 1, 1982), and by adding a new airworthiness directive (AD), amendment 39-10320, to read as follows:

98-04-07 McDonnell Douglas: Amendment 39-10320. Docket 98-NM-12-AD. Supersedes AD 81-26-03 R1, Amendment 39-4394.

Applicability: Model DC-9-10, -20, -30, -40, -50 series airplanes, Model DC-9-81 (MD-81) and DC-9-82 (MD-82) series airplanes, and C-9 (military) series airplanes; as listed in McDonnell Douglas Alert Service Bulletin DC9-53A147, Revision 05, dated November 24, 1997; certificated in any category.

Note 1: This AD applies to each airplane identified in the preceding applicability provision, regardless of whether it has been modified, altered, or repaired in the area subject to the requirements of this AD. For airplanes that have been modified, altered, or repaired so that the performance of the requirements of this AD is affected, the owner/operator must request approval for an alternative method of compliance in accordance with paragraph (f) of this AD. The request should include an assessment of the effect of the modification, alteration, or repair on the unsafe condition addressed by this AD; and, if the unsafe condition has not been eliminated, the request should include specific proposed actions to address it.

Compliance: Required as indicated, unless accomplished previously.

To detect and correct fatigue cracking in the upper fuselage skin in the area of the aft pressure bulkhead tee, which could result in rapid decompression of the fuselage and consequent reduced structural integrity of the airplane, accomplish the following:

Note 2: Where there are differences between the alert service bulletin and the AD, the AD prevails.

(a) Prior to the accumulation of 30,000 total landings, or within 25 days after the effective date of this AD, whichever occurs later, perform a visual inspection of the fuselage upper skin splice at the aft pressure bulkhead between longerons 14 left and 14 right to determine if an internal production titanium doubler has been installed.

(1) If results of the visual inspection reveal that an internal production titanium doubler has not been installed, prior to further flight, perform a visual inspection of the fuselage upper skin splice area at the aft pressure bulkhead between longerons 14 left and 14 right to determine if a permanent repair has been installed in accordance with McDonnell Douglas Alert Service Bulletin DC9-53A147, Revision 2, dated June 3, 1981; Revision 3, dated November 22, 1981; Revision 4, dated October 25, 1983; or Revision 05, dated November 24, 1997.

(i) If a permanent repair has been installed, no further action is required by this AD.

(ii) If a permanent repair has not been installed, and if a dye penetrant or HFEC inspection has been accomplished in accordance with AD 81-26-03 R1, within 4,000 landings following accomplishment of the last dye penetrant or HFEC inspection required by AD 81-26-03 R1, or within 90 days after the effective date of this AD, whichever occurs later, perform an HFEC inspection to detect skin cracks or failed fasteners of the unmodified area, in accordance with the Accomplishment Instructions of the alert service bulletin.

(iii) If a permanent repair has not been installed, and if a dye penetrant or HFEC inspection has not been accomplished in accordance with AD 81-26-03 R1, prior to further flight, perform a high frequency eddy current (HFEC) inspection to detect skin cracks or failed fasteners of the unmodified area, in accordance with the Accomplishment Instructions of the alert service bulletin.

(2) If results of the visual inspection reveal that an internal production titanium doubler has been installed, perform an HFEC inspection to detect skin cracks or failed fasteners of the upper skin splice area at the tee cap of the aft fuselage pressure bulkhead between longerons 14 left and 14 right, in accordance with the Accomplishment Instructions of the alert service bulletin at the time specified in paragraph (a)(2)(i) or (a)(2)(ii) of this AD, as applicable.

(i) For airplanes that have been previously inspected using LFEC techniques or have not been previously inspected, in accordance with AD 81-26-03 R1: Inspect within 90 days following accomplishment of the visual inspection required by paragraph (a) of this AD.

(ii) For airplanes that have been inspected previously using HFEC or dye penetrant techniques, in accordance with AD 81-26-03

R1: Inspect within 4,000 landings following accomplishment of the last HFEC or dye penetrant inspection required by AD 81-26-03 R1, or within 90 days following accomplishment of the visual inspection required by paragraph (a) of this AD, whichever occurs later.

(b) If no skin crack or failed fastener is detected during any inspection required by this AD, repeat the HFEC inspection required by paragraph (a) of this AD thereafter at intervals not to exceed 4,000 landings.

(c) If any failed fastener with no skin crack is detected during any inspection required by this AD, prior to further flight, replace the failed fastener with a new fastener, in accordance with the Accomplishment Instructions of McDonnell Douglas Alert Service Bulletin DC9-53A147, Revision 05, dated November 24, 1997, including Service Sketch 3145B and Service Sketch 3174C (both undated). Repeat the HFEC inspection required by paragraph (a) of this AD thereafter at intervals not to exceed 4,000 landings.

(d) If any skin crack is detected during any inspection required by this AD, prior to further flight, accomplish the interim repair in accordance with the Accomplishment Instructions of McDonnell Douglas Alert Service Bulletin DC9-53A147, Revision 05, dated November 24, 1997, including Service Sketch 3145B and Service Sketch 3174C (both undated). For the unmodified area, repeat the HFEC inspection required by paragraph (a) of this AD thereafter at intervals not to exceed 4,000 landings.

(e) Accomplishment of the permanent repair in accordance with the Accomplishment Instructions of McDonnell Douglas Alert Service Bulletin DC9-53A147, Revision 05, dated November 24, 1997, including Service Sketch 3145B and Service Sketch 3174C (both undated), constitutes terminating action for the repetitive inspection requirements of this AD.

Note 3: The permanent repair is required by AD 96-10-11, amendment 39-9618 (61 FR 24675, May 16, 1996) as part of the DC-9/MD-80 Aging Aircraft Service Action Requirements Document.

(f) An alternative method of compliance or adjustment of the compliance time that provides an acceptable level of safety may be used if approved by the Manager, Los Angeles Aircraft Certification Office (ACO), FAA, Transport Airplane Directorate. Operators shall submit their requests through an appropriate FAA Principal Maintenance Inspector, who may add comments and then send it to the Manager, Los Angeles ACO.

Note 4: Information concerning the existence of approved alternative methods of compliance with this AD, if any, may be obtained from the Los Angeles ACO.

(g) Special flight permits may be issued in accordance with sections 21.197 and 21.199 of the Federal Aviation Regulations (14 CFR 21.197 and 21.199) to operate the airplane to a location where the requirements of this AD can be accomplished.

(h) Except as provided by paragraphs (a) and (a)(1) of this AD, the inspections, replacement, interim repair, and permanent repair, if accomplished, shall be done in

accordance with McDonnell Douglas Alert Service Bulletin DC9-53A147, Revision 05, dated November 24, 1997, including Service Sketch 3145B and Service Sketch 3174C (both undated). This incorporation by reference was approved by the Director of the Federal Register in accordance with 5 U.S.C. 552(a) and 1 CFR part 51. Copies may be obtained from The Boeing Company, Douglas Products Division, 3855 Lakewood Boulevard, Long Beach, California 90846, Attention: Technical Publications Business Administration, Dept. C1-L51 (2-60). Copies may be inspected at the FAA, Transport Airplane Directorate, 1601 Lind Avenue, SW., Renton, Washington; or at the FAA, Los Angeles Aircraft Certification Office, 3960 Paramount Boulevard, Lakewood, California; or at the Office of the Federal Register, 800 North Capitol Street, NW., suite 700, Washington, DC.

(i) This amendment becomes effective on February 25, 1998.

Issued in Renton, Washington, on February 4, 1998.

Darrell M. Pederson,

Acting Manager, Transport Airplane Directorate, Aircraft Certification Service.

[FR Doc. 98-3263 Filed 2-9-98; 8:45 am]

BILLING CODE 4910-13-P

DEPARTMENT OF TRANSPORTATION

Federal Aviation Administration

14 CFR Part 39

[Docket No. 98-NM-23-AD; Amendment 39-10319; AD 98-04-06]

RIN 2120-AA64

Airworthiness Directives; Dornier Model 328-100 Series Airplanes

AGENCY: Federal Aviation Administration, DOT.

ACTION: Final rule; request for comments.

SUMMARY: This amendment adopts a new airworthiness directive (AD) that is applicable to all Dornier Model 328-100 series airplanes. This action requires repetitive visual inspections for signs of fuel leakage of the outer wing beginning with Rib 21 and continuing outward, and corrective action, if necessary. This amendment is prompted by issuance of mandatory continuing airworthiness information by a foreign civil airworthiness authority. The actions specified in this AD are intended to prevent fuel leakage on the outboard wing, which could result in a fuel explosion and fire.

DATES: Effective February 25, 1998.

The incorporation by reference of certain publications listed in the regulations is approved by the Director of the Federal Register as of February 25, 1998.

Comments for inclusion in the Rules Docket must be received on or before March 12, 1998.

ADDRESSES: Submit comments in triplicate to the Federal Aviation Administration (FAA), Transport Airplane Directorate, ANM-114, Attention: Rules Docket No. 98-NM-23-AD, 1601 Lind Avenue, SW., Renton, Washington 98055-4056.

The service information referenced in this AD may be obtained from FAIRCHILD DORNIER, DORNIER Luftfahrt GmbH, P.O. Box 1103, D-82230 Wessling, Germany. This information may be examined at the FAA, Transport Airplane Directorate, 1601 Lind Avenue, SW., Renton, Washington; or at the Office of the Federal Register, 800 North Capitol Street, NW., suite 700, Washington, DC.

FOR FURTHER INFORMATION CONTACT: Norman B. Martenson, Manager, International Branch, ANM-116, FAA, Transport Airplane Directorate, 1601 Lind Avenue, SW., Renton, Washington 98055-4056; telephone (425) 227-2110; fax (425) 227-1149.

SUPPLEMENTARY INFORMATION: The Luftfahrt-Bundesamt (LBA), which is the airworthiness authority for Germany, recently notified the FAA that an unsafe condition may exist on all Dornier Model 328-100 series airplanes. The LBA advises that during a routine line check, fuel leakage was found at Rib 21 on the left-hand outboard wing. The cause has been attributed to inadequate sealing of the fuel tanks located in each wing. Such fuel leakage, if not corrected, could result in a fuel explosion and fire.

Explanation of Relevant Service Information

Dornier has issued Alert Service Bulletin ASB-328-57-020, dated October 28, 1997, which describes procedures for repetitive visual inspections of the left and right-hand outer wings, beginning with Rib 21 and continuing outward, for signs of fuel leakage; and re-sealing of the respective fuel tank, if necessary. The LBA classified this alert service bulletin as mandatory and issued German airworthiness directive 1998-020, dated January 15, 1998, in order to assure the continued airworthiness of these airplanes in Germany.

FAA's Conclusions

This airplane model is manufactured in Germany and is type certificated for operation in the United States under the provisions of section 21.29 of the Federal Aviation Regulations (14 CFR 21.29) and the applicable bilateral

airworthiness agreement. Pursuant to this bilateral airworthiness agreement, the LBA has kept the FAA informed of the situation described above. The FAA has examined the findings of the LBA, reviewed all available information, and determined that AD action is necessary for products of this type design that are certificated for operation in the United States.

Explanation of Requirements of Rule

Since an unsafe condition has been identified that is likely to exist or develop on other airplanes of the same type design registered in the United States, this AD is being issued to prevent fuel leakage on the outboard wing, which could result in a fuel explosion and fire. This AD requires accomplishment of the actions specified in the alert service bulletin described previously.

Interim Action

This is considered to be interim action until final action is identified, at which time the FAA may consider further rulemaking.

Determination of Rule's Effective Date

Since a situation exists that requires the immediate adoption of this regulation, it is found that notice and opportunity for prior public comment hereon are impracticable, and that good cause exists for making this amendment effective in less than 30 days.

Comments Invited

Although this action is in the form of a final rule that involves requirements affecting flight safety and, thus, was not preceded by notice and an opportunity for public comment, comments are invited on this rule. Interested persons are invited to comment on this rule by submitting such written data, views, or arguments as they may desire. Communications shall identify the Rules Docket number and be submitted in triplicate to the address specified under the caption **ADDRESSES**. All communications received on or before the closing date for comments will be considered, and this rule may be amended in light of the comments received. Factual information that supports the commenter's ideas and suggestions is extremely helpful in evaluating the effectiveness of the AD action and determining whether additional rulemaking action would be needed.

Comments are specifically invited on the overall regulatory, economic, environmental, and energy aspects of the rule that might suggest a need to modify the rule. All comments

submitted will be available, both before and after the closing date for comments, in the Rules Docket for examination by interested persons. A report that summarizes each FAA-public contact concerned with the substance of this AD will be filed in the Rules Docket.

Commenters wishing the FAA to acknowledge receipt of their comments submitted in response to this rule must submit a self-addressed, stamped postcard on which the following statement is made: "Comments to Docket Number 98-NM-23-AD." The postcard will be date stamped and returned to the commenter.

Regulatory Impact

The regulations adopted herein will not have substantial direct effects on the States, on the relationship between the national government and the States, or on the distribution of power and responsibilities among the various levels of government. Therefore, in accordance with Executive Order 12612, it is determined that this final rule does not have sufficient federalism implications to warrant the preparation of a Federalism Assessment.

The FAA has determined that this regulation is an emergency regulation that must be issued immediately to correct an unsafe condition in aircraft, and that it is not a "significant regulatory action" under Executive Order 12866. It has been determined further that this action involves an emergency regulation under DOT Regulatory Policies and Procedures (44 FR 11034, February 26, 1979). If it is determined that this emergency regulation otherwise would be significant under DOT Regulatory Policies and Procedures, a final regulatory evaluation will be prepared and placed in the Rules Docket.

A copy of it, if filed, may be obtained from the Rules Docket at the location provided under the caption ADDRESSES.

List of Subjects in 14 CFR Part 39

Air transportation, Aircraft, Aviation safety, Incorporation by reference, Safety.

Adoption of the Amendment

Accordingly, pursuant to the authority delegated to me by the Administrator, the Federal Aviation Administration amends part 39 of the Federal Aviation Regulations (14 CFR part 39) as follows:

PART 39—AIRWORTHINESS DIRECTIVES

1. The authority citation for part 39 continues to read as follows:

Authority: 49 U.S.C. 106(g), 40113, 44701.

§ 39.13 [Amended]

2. Section 39.13 is amended by adding the following new airworthiness directive:

98-04-06 Dornier: Amendment 39-10319. Docket 98-NM-23-AD.

Applicability: All Model 328-100 series airplanes, certificated in any category.

Note 1: This AD applies to each airplane identified in the preceding applicability provision, regardless of whether it has been modified, altered, or repaired in the area subject to the requirements of this AD. For airplanes that have been modified, altered, or repaired so that the performance of the requirements of this AD is affected, the owner/operator must request approval for an alternative method of compliance in accordance with paragraph (b) of this AD. The request should include an assessment of the effect of the modification, alteration, or repair on the unsafe condition addressed by this AD; and, if the unsafe condition has not been eliminated, the request should include specific proposed actions to address it.

Compliance: Required as indicated, unless accomplished previously.

To prevent fuel leakage on the outboard wing, which could result in risk of a fuel explosion and fire, accomplish the following:

(a) Within 30 days after the effective date of this AD, perform a visual inspection of the left and right-hand outer wings, beginning with Rib 21 and continuing outward, for signs of fuel leakage, in accordance with Dornier Alert Service Bulletin ASB-328-57-020, dated October 28, 1997. If any sign of fuel leakage is detected, prior to further flight, re-seal the respective fuel tank in accordance with the alert service bulletin. Repeat the inspection at intervals not to exceed 1,500 flight hours or 6 months, whichever occurs first.

(b) An alternative method of compliance or adjustment of the compliance time that provides an acceptable level of safety may be used if approved by the Manager, International Branch, ANM-116, FAA, Transport Airplane Directorate. Operators shall submit their requests through an appropriate FAA Principal Maintenance Inspector, who may add comments and then send it to the Manager, International Branch, ANM-116.

Note 2: Information concerning the existence of approved alternative methods of compliance with this AD, if any, may be obtained from the International Branch, ANM-116.

(c) Special flight permits may be issued in accordance with sections 21.197 and 21.199 of the Federal Aviation Regulations (14 CFR 21.197 and 21.199) to operate the airplane to a location where the requirements of this AD can be accomplished.

(d) The actions shall be done in accordance with Dornier Alert Service Bulletin ASB-328-57-020, dated October 28, 1997. This incorporation by reference was approved by the Director of the Federal Register in accordance with 5 U.S.C. 552(a) and 1 CFR part 51. Copies may be obtained from

FAIRCHILD DORNIER, DORNIER Luftfahrt GmbH, P.O. Box 1103, D-82230 Wessling, Germany. Copies may be inspected at the FAA, Transport Airplane Directorate, 1601 Lind Avenue, SW., Renton, Washington; or at the Office of the Federal Register, 800 North Capitol Street, NW., suite 700, Washington, DC.

Note 3: The subject of this AD is addressed in German airworthiness directive 1998-020, dated January 15, 1998.

(e) This amendment becomes effective on February 25, 1998.

Issued in Renton, Washington, on February 4, 1998.

Darrell M. Pederson,

Acting Manager, Transport Airplane Directorate, Aircraft Certification Service. [FR Doc. 98-3264 Filed 2-9-98; 8:45 am]

BILLING CODE 4910-13-P

DEPARTMENT OF HEALTH AND HUMAN SERVICES

Food and Drug Administration

21 CFR Parts 522 and 529

New Animal Drugs; Change of Sponsor

AGENCY: Food and Drug Administration, HHS.

ACTION: Final rule.

SUMMARY: The Food and Drug Administration (FDA) is amending the animal drug regulations to reflect a change of sponsor for two abbreviated new animal drug applications (ANADA's) from Phoenix Pharmaceutical, Inc., to Phoenix Scientific, Inc.

EFFECTIVE DATE: February 10, 1998.

FOR FURTHER INFORMATION CONTACT: Thomas J. McKay, Center for Veterinary Medicine (HFV-102), Food and Drug Administration, 7500 Standish Pl., Rockville, MD 20855, 301-827-0213.

SUPPLEMENTARY INFORMATION: Phoenix Pharmaceutical, Inc., 4621 Easton Rd., P.O. Box 6457 Farleigh Station, St. Joseph, MO 64506-0457, has informed FDA that it has transferred ownership of, and all rights and interests in, approved ANADA 200-068 (*Oxytetracycline hydrochloride injection*) and ANADA 200-137 (*Gentamicin sulfate intrauterine solution*) to Phoenix Scientific, Inc., 3915 South 48th St. Terrace, P.O. Box 6457, St. Joseph, MO 64506-0457. Accordingly, FDA is amending the regulations in 21 CFR 522.1662a and 529.1044a to reflect the change of sponsor.

List of Subjects in 21 CFR Parts 522 and 529

Animal drugs.

Therefore, under the Federal Food, Drug, and Cosmetic Act and under authority delegated to the Commissioner of Food and Drugs and redelegated to the Center for Veterinary Medicine, 21 CFR parts 522 and 529 are amended as follows:

PART 522—IMPLANTATION OR INJECTABLE DOSAGE FORM NEW ANIMAL DRUGS

1. The authority citation for 21 CFR part 522 continues to read as follows:

Authority: 21 U.S.C. 360b.

§ 522.1662a [Amended]

2. Section 522.1662a *Oxytetracycline hydrochloride injection* is amended in paragraph (h)(2) by removing "057319" and adding in its place "059130".

PART 529—CERTAIN OTHER DOSAGE FORM NEW ANIMAL DRUGS

3. The authority citation for 21 CFR part 529 continues to read as follows:

Authority: 21 U.S.C. 360b.

§ 529.1044a [Amended]

4. Section 529.1044a *Gentamicin sulfate intrauterine solution* is amended in paragraph (b) by removing "057319" and adding in its place "059130".

Dated: January 28, 1998.

Andrew J. Beaulieu,
Acting Director, Office of New Animal Drug Evaluation, Center for Veterinary Medicine.
[FR Doc. 98-3294 Filed 2-9-98; 8:45 am]
BILLING CODE 4160-01-F

DEPARTMENT OF HEALTH AND HUMAN SERVICES

Food and Drug Administration
21 CFR Part 558

New Animal Drugs For Use In Animal Feeds; Salinomycin

AGENCY: Food and Drug Administration, HHS.

ACTION: Final rule.

SUMMARY: The Food and Drug Administration (FDA) is amending the animal drug regulations to reflect approval of a supplemental new animal drug application (NADA) filed by Hoffmann-La Roche, Inc. The NADA provides for use of an alternate formulation of salinomycin Type A medicated articles to make Type C medicated feeds.

EFFECTIVE DATE: February 10, 1998.

FOR FURTHER INFORMATION CONTACT: Mary G. Leadbetter, Center for Veterinary Medicine (HFV-143), Food

and Drug Administration, 7500 Standish Pl., Rockville, MD 20855, 301-594-1662.

SUPPLEMENTARY INFORMATION: Hoffmann-La Roche, Inc., Nutley, NJ 07110-1199, is sponsor of NADA 128-686 that provides for use of Bio-Cox® (salinomycin) Type A medicated articles to make Type C medicated feeds for broiler, roaster, and replacement chickens, and quail. The firm filed a supplement to the NADA that provides for use of a 60-grams-per-pound (g/lb) salinomycin Type A medicated article in addition to the currently approved 30-g/lb product. The supplemental NADA is approved as of January 9, 1998, and the regulations are amended in 21 CFR 558.550(a)(1) to reflect the approval.

Approval of this supplemental NADA does not require additional safety or effectiveness data or information. A freedom of information summary as provided under 21 CFR part 20 and 514.11(e)(2)(ii) is not required.

The agency has determined under 21 CFR 25.33(a)(3) that this action is of a type that does not individually or cumulatively have a significant effect on the human environment. Therefore, neither an environmental assessment nor an environmental impact statement is required.

List of Subjects in 21 CFR Part 558

Animal drugs, Animal feeds.

Therefore, under the Federal Food, Drug, and Cosmetic Act and under the authority delegated to the Commissioner of Food and Drugs and redelegated to the Center for Veterinary Medicine, 21 CFR part 558 is amended as follows:

PART 558—NEW ANIMAL DRUGS FOR USE IN ANIMAL FEEDS

1. The authority citation for 21 CFR part 558 continues to read as follows:

Authority: 21 U.S.C. 360b, 371.

§ 558.550 [Amended]

2. Section 558.550 *Salinomycin* is amended in paragraph (a)(1) by removing "30" and adding in its place "30 and 60".

Dated: January 28, 1998.

Andrew J. Beaulieu,
Acting Director, Office of New Animal Drug Evaluation, Center for Veterinary Medicine.
[FR Doc. 98-3293 Filed 2-9-98; 8:45 am]
BILLING CODE 4160-01-F

NATIONAL MEDIATION BOARD

29 CFR Part 1200

Repeal of Agency Promulgated Ethics Regulations

AGENCY: National Mediation Board.

ACTION: Final rule.

SUMMARY: The National Mediation Board (NMB) is repealing its regulations on the ethical conduct of employees. The repealed provisions are superseded by Office of Government Ethics (OGE) rules establishing uniform standards of conduct and financial disclosure requirements for executive branch employees.

DATES: This final rule is effective February 10, 1998.

FOR FURTHER INFORMATION CONTACT:

Ronald M. Etters, General Counsel, National Mediation Board, 1301 K Street, NW, Washington, DC 20572, 202-523-5944. This is not a toll-free number.

SUPPLEMENTARY INFORMATION: In 1967 the National Mediation Board (NMB) issued Part 1200 (29 CFR Part 1200, 32 FR 15827, November 17, 1967), primarily pursuant to Executive Order 11222 (30 FR 6469) and regulations issued by the Civil Service Commission (5 CFR 735.104). Executive Order 12674 (April 12, 1989), as modified by Executive Order 12731 (October 7, 1990), revoked Executive Order 11222 (section 501(a)) and directed the Office of Government Ethics (OGE) to "establish a single, comprehensive and clear set of executive-branch standards of conduct that shall be objective, reasonable and enforceable." (Section 201).

OGE issued 5 CFR Part 2635, Standards of Ethical Conduct for Employees of the Executive Branch (57 FR 35006, August 7, 1992). These standards of conduct superseded agency regulations promulgated pursuant to 5 CFR Part 735. The NMB is removing Part 1200 by repealing all provisions of Subparts A through D which were superseded when OGE's regulations took effect (February 3, 1993).

The NMB has determined that publication of a proposed rule is unnecessary since Part 1200 is duplicative and superseded by OGE rules establishing uniform standards of conduct and financial disclosure regulations for executive branch employees.

List of Subjects in 29 CFR 1200

Conflict of interests.

PART 1200—[REMOVED]

For the reasons set forth in the preamble, and under the authority of Executive Order 12674 of April 12, 1989, Part 1200 of Chapter X of Title 29 of the Code of Federal Regulations is removed.

Dated: February 1, 1998.

Stephen E. Crable,
Chief of Staff.

[FR Doc. 98-3114 Filed 2-9-98; 8:45 am]

BILLING CODE 7550-01-M

ENVIRONMENTAL PROTECTION AGENCY**40 CFR Part 51**

[FRL-5960-9]

Technical Amendments to Minor Amendments to Inspection/Maintenance Program Requirements; Correction of Effective Date Under Congressional Review Act (CRA)

AGENCY: Environmental Protection Agency (EPA).

ACTION: Direct final rule; correction of effective date under CRA.

SUMMARY: On September 23, 1996 (61 FR 49680), the Environmental Protection Agency published in the *Federal Register* a direct final rule changing a provision of the federal vehicle inspection and maintenance (I/M) rules relating to motorist compliance enforcement mechanisms for pre-existing programs, which established an effective date of November 22, 1996. This document corrects the effective date of the rule to February 10, 1998, to be consistent with sections 801 and 808 of the Congressional Review Act (CRA), enacted as part of the Small Business Regulatory Enforcement Fairness Act, 5 U.S.C. 801 and 808.

EFFECTIVE DATE: This rule is effective on February 10, 1998.

FOR FURTHER INFORMATION CONTACT: Tom Eagles, OAR, at (202) 260-5585.

SUPPLEMENTARY INFORMATION:**I. Background**

Section 801 of the CRA precludes a rule from taking effect until the agency promulgating the rule submits a rule report, which includes a copy of the rule, to each House of Congress and to the Comptroller General of the General Accounting Office (GAO). EPA recently discovered that it had inadvertently failed to submit the above rule as required; thus, although the rule was promulgated on September 23, 1996 (61

FR 49680) by operation of law, the rule did not take effect on November 22, 1996, as stated therein. Now that EPA has discovered its error, the rule is being submitted to both Houses of Congress and the GAO. This document amends the effective date of the rule consistent with the provisions of the CRA.

Section 553 of the Administrative Procedure Act, 5 U.S.C. 553 (b)(B), provides that, when an agency for good cause finds that notice and public procedure are impracticable, unnecessary or contrary to the public interest, an agency may issue a rule without providing notice and an opportunity for public comment. EPA has determined that there is good cause for making today's rule final without prior proposal and opportunity for comment because EPA merely is correcting the effective date of the promulgated rule to be consistent with the congressional review requirements of the Congressional Review Act as a matter of law and has no discretion in this matter. Thus, notice and public procedure are unnecessary. The Agency finds that this constitutes good cause under 5 U.S.C. 553(b)(B). Moreover, since today's action does not create any new regulatory requirements and affected parties have known of the underlying rule since September 23, 1996, EPA finds that good cause exists to provide for an immediate effective date pursuant to 5 U.S.C. 553(d)(3) and 808(2). Because the delay in the effective date was caused by EPA's inadvertent failure to submit the rule under the CRA, EPA does not believe that affected entities that acted in good faith relying upon the effective date stated in the September 23, 1996, *Federal Register* should be penalized if they were complying with the rule as promulgated.

II. Administrative Requirements

Under Executive Order 12866 (58 FR 51735, October 4, 1993), this action is not a "significant regulatory action" and is therefore not subject to review by the Office of Management and Budget. In addition, this action does not impose any enforceable duty or contain any unfunded mandate as described in the Unfunded Mandates Reform Act of 1995 (Pub. L. 104-4), or require prior consultation with State officials as specified by Executive Order 12875 (58 FR 58093, October 23, 1993), or involve special consideration of environmental justice related issues as required by Executive Order 12898 (59 FR 7629, February 16, 1994). Because this action is not subject to notice-and-comment requirements under the Administrative Procedure Act or any other statute, it is

not subject to the regulatory flexibility provisions of the Regulatory Flexibility Act (5 U.S.C. 601 *et seq.*). EPA's compliance with these statutes and Executive Orders for the underlying rule is discussed in the September 23, 1996, *Federal Register* document.

Pursuant to 5 U.S.C. 801(a)(1)(A), as added by the Small Business Regulatory Enforcement Fairness Act of 1996, EPA will submit a report containing this rule and other required information to the U.S. Senate, the U.S. House of Representatives and the Comptroller General of the General Accounting Office; however, in accordance with 5 U.S.C. 808(2), this rule is effective on February 10, 1998. This rule is not a "major rule" as defined in 5 U.S.C. 804(2).

This final rule only amends the effective date of the underlying rule; it does not amend any substantive requirements contained in the rule. Accordingly, to the extent it is available, judicial review is limited to the amended effective date.

Dated: January 30, 1998.

Carol Browner,
Administrator.

[FR Doc. 98-3033 Filed 2-9-98; 8:45 am]

BILLING CODE 6560-50-M

ENVIRONMENTAL PROTECTION AGENCY**40 CFR Part 52**

[FRL-5961-2]

Technical Amendments to Approval and Promulgation of Implementation Plans; State of Missouri; Correction of Effective Date Under Congressional Review Act (CRA)

AGENCY: Environmental Protection Agency (EPA).

ACTION: Direct final rule; correction of effective date under CRA.

SUMMARY: September 5, 1997 (62 FR 46880), the Environmental Protection Agency published in the *Federal Register* a direct final rule approving revisions in the Missouri State rules regarding conformity requirements in Kansas City and St. Louis, which established an effective date of November 4, 1997. This document corrects the effective date of the rule to February 10, 1998, to be consistent with sections 801 and 808 of the Congressional Review Act (CRA), enacted as part of the Small Business Regulatory Enforcement Fairness Act, 5 U.S.C. 801 and 808.

EFFECTIVE DATE: This rule is effective on February 10, 1998.

FOR FURTHER INFORMATION CONTACT:
Alice Todd, EPA Region VII, at (913)
551-7304.

SUPPLEMENTARY INFORMATION:

I. Background

Section 801 of the CRA precludes a rule from taking effect until the agency promulgating the rule submits a rule report, which includes a copy of the rule, to each House of Congress and to the Comptroller General of the General Accounting Office (GAO). EPA recently discovered that it had inadvertently failed to submit the above rule as required; thus, although the rule was promulgated on September 5, 1997 (62 FR 46880) by operation of law, the rule did not take effect on November 4, 1997, as stated therein. Now that EPA has discovered its error, the rule is being submitted to both Houses of Congress and the GAO. This document amends the effective date of the rule consistent with the provisions of the CRA.

Section 553 of the Administrative Procedure Act, 5 U.S.C. 553(b)(B), provides that, when an agency for good cause finds that notice and public procedure are impracticable, unnecessary or contrary to the public interest, an agency may issue a rule without providing notice and an opportunity for public comment. EPA has determined that there is good cause for making today's rule final without prior proposal and opportunity for comment because EPA merely is correcting the effective date of the promulgated rule to be consistent with the congressional review requirements of the Congressional Review Act as a matter of law and has no discretion in this matter. Thus, notice and public procedure are unnecessary. The Agency finds that this constitutes good cause under 5 U.S.C. 553(b)(B). Moreover, since today's action does not create any new regulatory requirements and affected parties have known of the underlying rule since September 5, 1997, EPA finds that good cause exists to provide for an immediate effective date pursuant to 5 U.S.C. 553(d)(3) and 808(2). Because the delay in the effective date was caused by EPA's inadvertent failure to submit the rule under the CRA, EPA does not believe that affected entities that acted in good faith relying upon the effective date stated in the September 5, 1997, **Federal Register** should be penalized if they were complying with the rule as promulgated.

II. Administrative Requirements

Under Executive Order 12866 (58 FR 51735, October 4, 1993), this action is not a "significant regulatory action" and

is therefore not subject to review by the Office of Management and Budget. In addition, this action does not impose any enforceable duty or contain any unfunded mandate as described in the Unfunded Mandates Reform Act of 1995 (Pub. L. 104-4), or require prior consultation with State officials as specified by Executive Order 12875 (58 FR 58093, October 28, 1993), or involve special consideration of environmental justice related issues as required by Executive Order 12898 (59 FR 7629, February 16, 1994). Because this action is not subject to notice-and-comment requirements under the Administrative Procedure Act or any other statute, it is not subject to the regulatory flexibility provisions of the Regulatory Flexibility Act (5 U.S.C. 601 *et seq.*). EPA's compliance with these statutes and Executive Orders for the underlying rule is discussed in September 5, 1997, **Federal Register** document.

Pursuant to 5 U.S.C. 801(a)(1)(A), as added by the Small Business Regulatory Enforcement Fairness Act of 1996, EPA will submit a report containing this rule and other required information to the U.S. Senate, the U.S. House of Representatives and the Comptroller General of the General Accounting Office; however, in accordance with 5 U.S.C. 808(2), this rule is effect on February 10, 1998. This rule is not a "major rule" as defined in 5 U.S.C. 804(2).

This final rule only amends the effective date of the underlying rule; it does not amend any substantive requirements contained in the rule. Accordingly, to the extent it is available, judicial review is limited to the amended effective date. Pursuant to section 307(b)(1) of the Clean Air Act, challenges to this amendment must be brought within 60 days of publication of the amendment.

Dated: January 30, 1998.

Carol Browner,
Administrator.

[FR Doc. 98-3036 Filed 2-9-98; 8:45 am]

BILLING CODE 6560-50-M

ENVIRONMENTAL PROTECTION AGENCY

40 CFR Part 52

[FRL-5960-8]

Technical Amendments to Approval and Promulgation of Implementation Plans; Ohio; Correction of Effective Date Under Congressional Review Act (CRA)

AGENCY: Environmental Protection Agency (EPA).

ACTION: Direct final rule; correction of effective date under CRA.

SUMMARY: On September 12, 1997 (62 FR 47946), the Environmental Protection Agency published in the **Federal Register** a direct final rule approving an Ohio State Implementation Plan revision request under the Clean Air Act (CAA), which established an effective date of November 12, 1997. This document corrects the effective date of the rule to February 10, 1998, to be consistent with sections 801 and 808 of the Congressional Review Act (CRA), enacted as part of the Small Business Regulatory Enforcement Fairness Act, 5 U.S.C. 801 and 808.

EFFECTIVE DATE: This rule is effective on February 10, 1998.

FOR FURTHER INFORMATION CONTACT: Dan Werbie, EPA Region V, at (312) 353-5791.

SUPPLEMENTARY INFORMATION:

I. Background

Section 801 of the CRA precludes a rule from taking effect until the agency promulgating the rule submits a rule report, which includes a copy of the rule, to each House of Congress and to the Comptroller General of the General Accounting Office (GAO). EPA recently discovered that it had inadvertently failed to submit the above rule as required; thus, although the rule was promulgated on September 12, 1997 (62 FR 47946) by operation of law, the rule did not take effect on November 12, 1997, as stated therein. Now that EPA has discovered its error, the rule is being submitted to both House of Congress and the GAO. This document amends the effective date of the rule consistent with the provisions of the CRA.

Section 553 of the Administrative Procedure Act, 5 U.S.C. 553(b)(B), provides that, when an agency for good cause finds that notice and public procedure are impracticable, unnecessary or contrary to the public interest, an agency may issue a rule without providing notice and an

opportunity for public comment. EPA has determined that there is good cause for making today's rule final without prior proposal and opportunity for comment because EPA merely is correcting the effective date of the promulgated rule to be consistent with the congressional review requirements of the Congressional Review Act as a matter of law and has no discretion in this matter. Thus, notice and public procedure are unnecessary. The Agency finds that this constitutes good cause under 5 U.S.C. 553(b)(B). Moreover, since today's action does not create any new regulatory requirements and affected parties have known of the underlying rule since September 12, 1997, EPA finds that good cause exists to provide for an immediate effective date pursuant to 5 U.S.C. 553(d)(3) and 808(2).

Because the delay in the effective date was caused by EPA's inadvertent failure to submit the rule under the CRA, EPA does not believe that affected entities that acted in good faith relying upon the effective date stated in the September 12, 1997, *Federal Register* should be penalized if they are complying with the rule as promulgated.

II. Administrative Requirements

Under Executive Order 12866 (58 FR 51735, October 4, 1993), this action is not a "significant regulatory action" and is therefore not subject to review by the Office of Management and Budget. In addition, this action does not impose any enforceable duty or contain any unfunded mandate as described in the Unfunded Mandates Reform Act of 1995 (Pub. L. 104-4), or require prior consultation with State officials as specified by Executive Order 12875 (58 FR 58093, October 28, 1993), or involve special consideration of environmental justice related issues as required by Executive Order 12898 (59 FR 7629, February 16, 1994). Because this action is not subject to notice-and-comment requirements under the Administrative Procedure Act or any other statute, it is not subject to the regulatory flexibility provisions of the Regulatory Flexibility Act (5 U.S.C. 601 *et seq.*). EPA's compliance with these statutes and Executive Orders for the underlying rule is discussed in September 12, 1997, *Federal Register* document.

Pursuant to 5 U.S.C. 801(a)(1)(A), as added by the Small Business Regulatory Enforcement Fairness Act of 1996, EPA will submit a report containing this rule and other required information to the U.S. Senate, the U.S. House of Representatives and the Comptroller General of the General Accounting Office; however, in accordance with 5

U.S.C. 808(2), this rule is effective on February 10, 1998. This rule is not a "major rule" as defined in 5 U.S.C. 804(2).

This final rule only amends the effective date of the underlying rule; it does not amend any substantive requirements contained in the rule. Accordingly, to the extent it is available, judicial review is limited to the amended effective date. Pursuant to section 307(b)(1) of the Clean Air Act, challenges to this amendment must be brought within 60 days of publication of the amendments.

Dated: January 30, 1998.

Carol Browner,
Administrator.

[FR Doc. 98-3021 Filed 2-9-98; 8:45 am]

BILLING CODE 6560-50-M

ENVIRONMENTAL PROTECTION AGENCY

40 CFR Part 52

[FRL-5961-1]

Technical Amendments to Approval and Promulgation of Implementation Plan; Minnesota Correction of Effective Date Under Congressional Review Act (CRA)

AGENCY: Environmental Protection Agency (EPA).

ACTION: Direct final rule; correction of effective date under CRA.

SUMMARY: On October 23, 1997 (62 FR 55170), the Environmental Protection Agency published in the *Federal Register* a direct final rule approving Minnesota's 1993 periodic carbon monoxide (CO) emission inventory, which established an effective date of December 22, 1997. This document corrects the effective date of the rule to February 10, 1998, to be consistent with sections 801 and 808 of the Congressional Review Act (CRA), enacted as part of the Small Business Regulatory Enforcement Fairness Act, 5 U.S.C. 801 and 808.

EFFECTIVE DATE: This rule is effective on February 10, 1998.

FOR FURTHER INFORMATION CONTACT: Dan Werbie, EPA Region V, at (312) 353-5791.

SUPPLEMENTARY INFORMATION:

I. Background

Section 801 of the CRA precludes a rule from taking effect until the agency promulgating the rule submits a rule report, which includes a copy of the rule, to each House of Congress and to the Comptroller General of the General

Accounting Office (GAO). EPA recently discovered that it had inadvertently failed to submit the above rule as required; thus, although the rule was promulgated on October 23, 1997 (62 FR 55170) by operation of law, the rule did not take effect on December 22, 1997, as stated therein. Now that EPA has discovered its error, the rule is being submitted to both Houses of Congress and the GAO. This document amends the effective date of the rule consistent with the provisions of the CRA.

Because the delay in the effective date was caused by EPA's inadvertent failure to submit the rule under the CRA, EPA does not believe that affected entities that acted in good faith relying upon the effective date stated in the October 23, 1997, *Federal Register* should be penalized if they were complying with the rule as promulgated.

II. Administrative Requirements

Under Executive Order 12866 (58 FR 51735, October 4, 1993), this action is not a "significant regulatory action" and is therefore not subject to review by the Office of Management and Budget. In addition, this action does not impose any enforceable duty or contain any unfunded mandate as described in the Unfunded Mandates Reform Act of 1995 (Pub. L. 104-4), or require prior consultation with State officials as specified by Executive Order 12875 (58 FR 58093, October 28, 1993), or involve special consideration of environmental justice related issues as required by Executive Order 12898 (59 FR 7629, February 16, 1994). Because this action is not subject to notice-and-comment requirements under the Administrative Procedure Act or any other statute, it is not subject to the regulatory flexibility provisions of the Regulatory Flexibility Act (5 U.S.C. 601 *et seq.*). EPA's compliance with these statutes and Executive Orders for the underlying rule is discussed in the October 23, 1997, *Federal Register* document.

Pursuant to 5 U.S.C. 801(a)(1)(A), as added by the Small Business Regulatory Enforcement Fairness Act of 1996, EPA will submit a report containing this rule and other required information to the U.S. Senate, the U.S. House of Representatives and the Comptroller General of the General Accounting Office; however, in accordance with 5 U.S.C. 808(2), this rule is effective on February 10, 1998. This rule is not a "major rule" as defined in 5 U.S.C. 804(2).

This final rule only amends the effective date of the underlying rule; it does not amend any substantive requirements contained in the rule. Accordingly, to the extent it is available,

judicial review is limited to the amended effective date. Pursuant to section 307(b)(1) of the Clean Air Act, challenges to this amendment must be brought within 60 days of publication of the amendment.

Dated: January 30, 1998.

Carol Browner,
Administrator.

[FR Doc. 98-3019 Filed 2-9-98; 8:45 am]

BILLING CODE 6560-50-M

ENVIRONMENTAL PROTECTION AGENCY

40 CFR Part 52

[FRL-5960-7]

Technical Amendments to Approval and Promulgation of Implementation Plans; Washington; Correction of Effective Date Under Congressional Review Act (CRA)

AGENCY: Environmental Protection Agency (EPA).

ACTION: Direct final rule; correction of effective date under CRA.

SUMMARY: On September 23, 1996 (61 FR 49688), the Environmental Protection Agency published in the *Federal Register* a direct final rule approving several minor revisions to the State of Washington Implementation Plan (SIP) and, at the same time, taking no action on two sections of the revisions which are unrelated to the purposes of the SIP, which established an effective date of November 22, 1996. This document corrects the effective date of the rule to February 10, 1998, to be consistent with sections 801 and 808 of the Congressional Review Act (CRA), enacted as part of the Small Business Regulatory Enforcement Fairness Act, 5 U.S.C. 801 and 808.

EFFECTIVE DATE: This rule is effective on February 10, 1998.

FOR FURTHER INFORMATION CONTACT: Robyn Meeker, EPA Region X, at (206) 553-8579.

SUPPLEMENTARY INFORMATION:

I. Background

Section 801 of the CRA precludes a rule from taking effect until the agency promulgating the rule submits a rule report, which includes a copy of the rule, to each House of Congress and to the Comptroller General of the General Accounting Office (GAO). EPA recently discovered that it had inadvertently failed to submit the above rule as required; thus, although the rule was promulgated on September 23, 1996 (61 FR 49688) by operation of law, the rule

did not take effect on November 22, 1996, as stated therein. Now that EPA has discovered its error, the rule is being submitted to both Houses of Congress and the GAO. This document amends the effective date of the rule consistent with the provisions of the CRA.

Section 553 of the Administrative Procedure Act, 5 U.S.C. 553(b)(B), provides that, when an agency for good cause finds that notice and public procedure are impracticable, unnecessary or contrary to the public interest, an agency may issue a rule without providing notice and an opportunity for public comment. EPA has determined that there is good cause for making today's rule final without prior proposal and opportunity for comment because EPA merely is correcting the effective date of the promulgated rule to be consistent with the congressional review requirements of the Congressional Review Act as a matter of law and has no discretion in this matter. Thus, notice and public procedure are unnecessary. The Agency finds that this constitutes good cause under 5 U.S.C. 553(b)(B). Moreover, since today's action does not create any new regulatory requirements and affected parties have known of the underlying rule since September 23, 1996, EPA finds that good cause exists to provide for an immediate effective date pursuant to 5 U.S.C. 553(d)(3) and 808(2). Because the delay in the effective date was caused by EPA's inadvertent failure to submit the rule under the CRA, EPA does not believe that affected entities that acted in good faith relying upon the effective date stated in the September 23, 1996, *Federal Register* should be penalized if they were complying with the rule as promulgated.

II. Administrative Requirements

Under Executive Order 12866 (58 FR 51735, October 4, 1993), this action is not a "significant regulatory action" and is therefore not subject to review by the Office of Management and Budget. In addition, this action does not impose any enforceable duty or contain any unfunded mandate as described in the Unfunded Mandates Reform Act of 1995 (Pub. L. 104-4), or require prior consultation with State officials as specified by Executive Order 12875 (58 FR 58093, October 28, 1993), or involve special consideration of environmental justice related issues as required by Executive Order 12898 (59 FR 7629, February 16, 1994). Because this action is not subject to notice-and-comment requirements under the Administrative Procedure Act or any other statute, it is not subject to the regulatory flexibility

provisions of the Regulatory Flexibility Act (5 U.S.C. 601 *et seq.*). EPA's compliance with these statutes and Executive Orders for the underlying rule is discussed in the September 23, 1996, *Federal Register* document.

Pursuant to 5 U.S.C. 801(a)(1)(A), as added by the Small Business Regulatory Enforcement Fairness Act of 1996, EPA will submit a report containing this rule and other required information to the U.S. Senate, the U.S. House of Representatives and the Comptroller General of the General Accounting Office; however, in accordance with 5 U.S.C. 808(2), this rule is effective on February 10, 1998. This rule is not a "major rule" as defined in 5 U.S.C. 804(2).

This final rule only amends the effective date of the underlying rule; it does not amend any substantive requirements contained in the rule. Accordingly, to the extent it is available, judicial review is limited to the amended effective date. Pursuant to section 307(b)(1) of the Clean Air Act, challenges to this amendment must be brought within 60 days of publication of the amendment.

Dated: January 30, 1998.

Carol Browner,
Administrator.

[FR Doc. 98-3018 Filed 2-9-98; 8:45 am]

BILLING CODE 6560-50-M

ENVIRONMENTAL PROTECTION AGENCY

40 CFR Part 52

[FRL-5960-6]

Technical Amendments to Approval and Promulgation of Implementation Plans; State of Missouri; Correction of Effective Date Under Congressional Review Act (CRA)

AGENCY: Environmental Protection Agency (EPA).

ACTION: Direct final rule; correction of effective date under CRA.

SUMMARY: On July 29, 1996 (61 FR 39334), the Environmental Protection Agency published in the *Federal Register* a direct final rule concerning the final action to correcting a previous action published on February 29, 1996, that approved and incorporated multiple amendments to Missouri rule 10 CSR 10-6.110 into the State Implementation Plan (SIP), which established an effective date of September 27, 1996. This document corrects the effective date of the rule to February 10, 1998 to be consistent with

sections 801 and 808 of the Congressional Review Act (CRA), enacted as part of the Small Business Regulatory Enforcement Fairness Act, 5 U.S.C. 801 and 808.

EFFECTIVE DATE: This rule is effective on February 10, 1998.

FOR FURTHER INFORMATION CONTACT: Sonya Moore, EPA Region VIII, at (303) 312-6825.

SUPPLEMENTARY INFORMATION:

I. Background

Section 801 of the CRA precludes a rule from taking effect until the agency promulgating the rule submits a rule report, which includes a copy of the rule, to each House of Congress and to the Comptroller General of the General Accounting Office (GAO). EPA recently discovered that it had inadvertently failed to submit the above rule as required; thus, although the rule was promulgated on July 29, 1996 (61 FR 39334) by operation of law, the rule did not take effect on September 27, 1996, as stated therein. Now that EPA has discovered its error, the rule is being submitted to both Houses of Congress and the GAO. This document amends the effective date of the rule consistent with the provisions of the CRA.

Section 553 of the Administrative Procedure Act, 5 U.S.C. 553(b)(B), provides that, when an agency for good cause finds that notice and public procedure are impracticable, unnecessary or contrary to the public interest, an agency may issue a rule without providing notice and an opportunity for public comment. EPA has determined that there is good cause for making today's rule final without prior proposal and opportunity for comment because EPA merely is correcting the effective date of the promulgated rule to be consistent with the congressional review requirements of the Congressional Review Act as a matter of law and has no discretion in this matter. Thus, notice and public procedure are unnecessary. The Agency finds that this constitutes good cause under 5 U.S.C. 553(b)(B). Moreover, since today's action does not create any new regulatory requirements and affected parties have known of the underlying rule since July 29, 1996, EPA finds that good cause exists to provide for an immediate effective date pursuant to 5 U.S.C. 553(d)(3) and 808(2).

Because the delay in the effective date was caused by EPA's inadvertent failure to submit the rule under the CRA, EPA does not believe that affected entities that acted in good faith relying upon the effective date stated in the July 29, 1996, *Federal Register* should be penalized if

they were complying with the rule as promulgated.

II. Administrative Requirements

Under Executive Order 12866 (58 FR 51735, October 4, 1993), this action is not a "significant regulatory action" and is therefore not subject to review by the Office of Management and Budget. In addition, this action does not impose any enforceable duty or contain any unfunded mandate as described in the Unfunded Mandates Reform Act of 1995 (Pub. L. 104-4), or require prior consultation with State officials as specified by Executive Order 12875 (58 FR 58093, October 28, 1993), or involve special consideration of environmental justice related issues as required by Executive Order 12898 (59 FR 7629, February 16, 1994). Because this action is not subject to notice-and-comment requirements under the Administrative Procedure Act or any other statute, it is not subject to the regulatory flexibility provisions of the Regulatory Flexibility Act (5 U.S.C. 601 *et seq.*). EPA's compliance with these statutes and Executive Orders for the underlying rule is discussed in the July 29, 1996, *Federal Register* document.

Pursuant to 5 U.S.C. 801(a)(1)(A), as added by the Small Business Regulatory Enforcement Fairness Act of 1996, EPA will submit a report containing this rule and other required information to the U.S. Senate, the U.S. House of Representatives and the Comptroller General of the General Accounting Office; however, in accordance with 5 U.S.C. 808(2), this rule is effective on February 10, 1998. This rule is not a "major rule" as defined in 5 U.S.C. 804(2).

This final rule only amends the effective date of the underlying rule; it does not amend any substantive requirements contained in the rule. Accordingly, to the extent it is available, judicial review is limited to the amended effective date. Pursuant to section 307(b)(1) of the Clean Air Act, challenges to this amendment must be brought within 60 days of publication of the amendment.

Dated: January 30, 1998.

Carol Browner,
Administrator.

[FR Doc. 98-3017 Filed 2-9-98; 8:45 am]

BILLING CODE 6560-50-M

ENVIRONMENTAL PROTECTION AGENCY

40 CFR Part 52

[FRL-5960-5]

Technical Amendments to Approval and Promulgation of Maintenance Plan Revision; Ohio; Correction of Effective Date Under Congressional Review Act (CRA)

AGENCY: Environmental Protection Agency (EPA).

ACTION: Direct final rule; correction of effective date under CRA.

SUMMARY: On August 25, 1997 (62 FR 44903), the Environmental Protection Agency published in the *Federal Register* a direct final rule approving a June 10, 1997, request from Ohio, for State Implementation Plan maintenance plan revisions for the following areas: Toledo area (including Lucas and Wood counties), the Cleveland-Akron-Lorain area (including Lorain, Cuyahoga, Lake, Ashtabula, Geauga, Medina, Summit and Portage counties), and the Dayton-Springfield area (including Montgomery, Clark, Greene, and Miami counties), which established an effective date of October 24, 1997. This document corrects the effective date of the rule to February 10, 1998, to be consistent with sections 801 and 808 of the Congressional Review Act (CRA), enacted as part of the Small Business Regulatory Enforcement Fairness Act, 5 U.S.C. 801 and 808.

EFFECTIVE DATE: This rule is effective on February 10, 1998.

FOR FURTHER INFORMATION CONTACT: Dan Werbie, EPA Region V, at (312) 353-5791.

SUPPLEMENTARY INFORMATION:

I. Background

Section 801 of the CRA precludes a rule from taking effect until the agency promulgating the rule submits a rule report, which includes a copy of the rule, to each House of Congress and to the Comptroller General of the General Accounting Office (GAO). EPA recently discovered that it had inadvertently failed to submit the above rule as required; thus, although the rule was promulgated on August 25, 1997 (62 FR 44903) by operation of law, the rule did not take effect on October 24, 1997, as stated therein. Now that EPA has discovered its error, the rule is being submitted to both Houses of Congress and the GAO. This document amends the effective date of the rule consistent with the provisions of the CRA.

Section 553 of the Administrative Procedure Act, 5 U.S.C. 553(b)(B),

provides that, when an agency for good cause finds that notice and public procedure are impracticable, unnecessary or contrary to the public interest, an agency may issue a rule without providing notice and an opportunity for public comment. EPA has determined that there is good cause for making today's rule final without prior proposal and opportunity for comment because EPA merely is correcting the effective date of the promulgated rule to be consistent with the congressional review requirements of the Congressional Review Act as a matter of law and has no discretion in this matter. Thus, notice and public procedure are unnecessary. The Agency finds that this constitutes good cause under 5 U.S.C. 553(b)(B). Moreover, since today's action does not create any new regulatory requirements and affected parties have known of the underlying rule since August 25, 1997, EPA finds that good cause exists to provide for an immediate effective date pursuant to 5 U.S.C. 553(d)(3) and 808(2). Because the delay in the effective date was caused by EPA's inadvertent failure to submit the rule under the CRA, EPA does not believe that affected entities that acted in good faith relying upon the effective date stated in the August 25, 1997, **Federal Register** should be penalized if they were complying with the rule as promulgated.

II. Administrative Requirements

Under Executive Order 12866 (58 FR 51735, October 4, 1993), this action is not a "significant regulatory action" and is therefore not subject to review by the Office of Management and Budget. In addition, this action does not impose any enforceable duty or contain any unfunded mandate as described in the Unfunded Mandates Reform Act of 1995 (Pub. L. 104-4), or require prior consultation with State officials as specified by Executive Order 12875 (58 FR 58093, October 28, 1993), or involve special consideration of environmental justice related issues as required by Executive Order 12898 (59 FR 7629, February 16, 1994). Because this action is not subject to notice-and-comment requirements under the Administrative Procedure Act or any other statute, it is not subject to the regulatory flexibility provisions of the Regulatory Flexibility Act (5 U.S.C. 601 *et seq.*). EPA's compliance with these statutes and Executive Orders for the underlying rule is discussed in the August 25, 1997, **Federal Register** document.

Pursuant to 5 U.S.C. 801(a)(1)(A), as added by the Small Business Regulatory Enforcement Fairness Act of 1996, EPA,

will submit a report containing this rule and other required information to the U.S. Senate, the U.S. House of Representatives and the Comptroller General of the General Accounting Office; however, in accordance with 5 U.S.C. 808(2), this rule is effective on February 10, 1998. This rule is not a "major rule" as defined in 5 U.S.C. 804(2).

This final rule only amends the effective date of the underlying rule; it does not amend any substantive requirements contained in the rule. Accordingly, to the extent it is available, judicial review is limited to the amended effective date. Pursuant to section 307(b)(1) of the Clean Air Act, challenges to this amendment must be brought within 60 days of publication of the amendment.

Dated: January 30, 1998.

Carol Browner,
Administrator.

[FR Doc. 98-3015 Filed 2-9-98; 8:45 am]

BILLING CODE 6560-50-M

ENVIRONMENTAL PROTECTION AGENCY

40 CFR Part 52

[MIS6-01-7264a; FRL-5961-8]

Approval and Promulgation of State Implementation Plan; Michigan

AGENCY: Environmental Protection Agency.

ACTION: Direct final rule.

SUMMARY: On May 16, 1996, and September 23, 1997, the Michigan Department of Environmental Quality (MDEQ) submitted a revision to the Michigan State Implementation Plan (SIP) that included Part 55 of Act 451 of 1994, the Natural Resources and Environmental Protection Act (Part 55). Part 55 is a recodification of the Air Pollution Control Act, 1965 Public Act 348. On December 30, 1997, MDEQ withdrew most of Part 55. In this action, the United States Environmental Protection Agency (USEPA) is approving sections 324.5524 and 324.5525 which contain control requirements and applicable definitions for fugitive dust sources.

In the proposed rules section of this **Federal Register**, the USEPA is proposing approval of, and soliciting comments on, this requested SIP revision. If adverse comments are received on this action, the USEPA will withdraw this final rule and address the comments received in response to this action in a final rule on the related

proposed rule, which is being published in the proposed rules section of this **Federal Register**. A second public comment period will not be held. Parties interested in commenting on this action should do so at this time. This approval makes federally enforceable the State's rule that has been incorporated by reference.

DATES: The "direct final" is effective on April 13, 1998, unless USEPA receives adverse or critical comments by March 12, 1998. If the effective date is delayed, timely notice will be published in the **Federal Register**.

ADDRESSES: Written comments should be sent to: Carlton T. Nash, Chief, Regulation Development Section, Air Programs Branch (AR-18J), U.S. Environmental Protection Agency, 77 West Jackson Boulevard, Chicago, Illinois 60604.

Copies of the proposed SIP revision and USEPA's analysis are available for inspection at the U.S. Environmental Protection Agency, Region 5, Air and Radiation Division, 77 West Jackson Boulevard, Chicago, Illinois 60604. (Please telephone Kathleen D'Agostino at (312) 886-1767 before visiting the Region 5 Office.)

FOR FURTHER INFORMATION CONTACT: Kathleen D'Agostino, Environmental Engineer, Regulation Development Section, Air Programs Branch (AR-18J), U.S. Environmental Protection Agency, Region 5, Chicago, Illinois 60604, (312) 886-1767.

SUPPLEMENTARY INFORMATION: On May 16, 1996, the Michigan Department of Environmental Quality (MDEQ) submitted a revision to the Michigan State Implementation Plan for New Source Review (NSR). Included in this submittal was Part 55 of Act 451 of 1994, the Natural Resources and Environmental Protection Act (Part 55), which recodifies the Air Pollution Control Act, 1965 Public Act 348. Part 55 in the May 16, 1996 submittal was incomplete in that the copy submitted had only the odd pages. On September 23, 1997, the State supplemented its original submittal with a complete copy of Part 55. On December 30, 1997, MDEQ withdrew all of Part 55 except for sections 324.5505, 324.5510, 324.5511, 324.5524 and 324.5525 and reaffirmed that Part 55 replaces the Air Pollution Control Act, 1965 Public Act 348, as the enabling legislation for Michigan's air pollution control program. This action only addresses those sections 324.5524 and 324.5525. Sections 324.5505, 324.5510 and 324.5511 pertain to New Source Review (NSR) and will be addressed when

USEPA takes action on the State's NSR SIP.

Sections 324.5524 and 324.5525 contain control requirements and applicable definitions for fugitive dust sources. These control requirements and definitions are very similar to those included in rules approved by USEPA in the State's particulate matter SIP. These sections are acceptable and USEPA is approving sections 324.5524 and 324.5525 for incorporation into the SIP.

Because the USEPA considers this action noncontroversial and routine, we are approving it without prior proposal. This action will become effective on April 13, 1998. However, if we receive adverse comments by March 12, 1998, USEPA will publish a document that withdraws this action.

Nothing in this action should be construed as permitting, allowing or establishing a precedent for any future request for revision to any SIP. The USEPA shall consider each request for revision to the SIP in light of specific technical, economic, and environmental factors and in relation to relevant statutory and regulatory requirements.

This action has been classified as a Table 3 action for signature by the Regional Administrator under the procedures published in the *Federal Register* on January 19, 1989 (54 FR 2214-2225), as revised by a July 10, 1995 memorandum from Mary Nichols, Assistant Administrator for Air and Radiation. The Office of Management and Budget (OMB) has exempted this regulatory action from E.O. 12866 review.

Under the Regulatory Flexibility Act, 5 U.S.C. 600 *et seq.*, USEPA must prepare a regulatory flexibility analysis assessing the impact of any proposed or final rule on small entities (5 U.S.C. 603 and 604). Alternatively, USEPA may certify that the rule will not have a significant impact on a substantial number of small entities. Small entities include small businesses, small not-for-profit enterprises, and government entities with jurisdiction over populations of less than 50,000.

This approval does not create any new requirements. Therefore, I certify that this action does not have a significant impact on any small entities affected. Moreover, due to the nature of the Federal-State relationship under the Act, preparation of the regulatory flexibility analysis would constitute Federal inquiry into the economic reasonableness of the State action. The Act forbids USEPA to base its actions concerning SIPs on such grounds. *Union Electric Co. v. U.S. USEPA*, 427 U.S. 246, 256-66 (1976).

Under section 202 of the Unfunded Mandates Reform Act of 1995 ("Unfunded Mandates Act"), signed into law on March 22, 1995, the USEPA must prepare a budgetary impact statement to accompany any proposed or final rule that includes a Federal mandate that may result in estimated costs to State, local, or tribal governments in the aggregate, or to the private sector, of \$100 million or more. Under section 205, the USEPA must select the most cost-effective and least burdensome alternative that achieves the objectives of the rule and is consistent with statutory requirements. Section 203 requires the USEPA to establish a plan for informing and advising any small governments that may be significantly or uniquely impacted by the rule.

The USEPA has determined that the approval action promulgated today does not include a Federal mandate that may result in estimated costs of \$100 million or more to either State, local, or tribal governments in the aggregate, or to the private sector. This Federal action approves into the SIP requirements already existing under State or local law, and imposes no new Federal requirements. Accordingly, no additional costs to State, local, or tribal governments, or the private sector, result from this action.

Under 5 U.S.C. 801(a)(1)(A) as added by the Small Business Regulatory Enforcement Fairness Act of 1996, USEPA submitted a report containing this rule and other required information to the U.S. Senate, the U.S. House of Representatives and the Comptroller General of the General Accounting Office prior to publication of the rule in today's *Federal Register*. This rule is not a "major rule" as defined by 5 U.S.C. 804(2).

Under section 307(b)(1) of the Act, petitions for judicial review of this action must be filed in the United States Court of Appeals for the appropriate circuit by April 13, 1998. Filing a petition for reconsideration by the Administrator of this final rule does not affect the finality of this rule for the purposes of judicial review, nor does it extend the time within which a petition for judicial review may be filed and shall not postpone the effectiveness of such rule or action. This action may not be challenged later in proceedings to enforce its requirements (see section 307(b)(2)).

List of Subjects in 40 CFR Part 52

Environmental protection, Air pollution control, Hydrocarbons, Incorporation by reference, Intergovernmental relations, Ozone,

Reporting and recordkeeping requirements.

Dated: January 12, 1998.

David A. Ullrich,

Acting Regional Administrator, Region V.

40 CFR part 52 is amended as follows:

PART 52—[AMENDED]

1. The authority citation for part 52 continues to read as follows:

Authority: 42 U.S.C. 7401 *et seq.*

Subpart X—Michigan

2. Section 52.1170 is amended by adding paragraph (c)(110) to read as follows:

§ 52.1170 Identification of plan.

* * * * *

(c) * * *

(110) A revision to Michigan's State Implementation Plan (SIP), containing part of Michigan's Natural Resources and Environmental Protection Act, was submitted by the Michigan Department of Environmental Quality (MDEQ) on May 16, 1996, and supplemented on September 23, 1997. On December 30, 1997, MDEQ withdrew much of the original submittal. The revision incorporated below contains control requirements and applicable definitions for fugitive dust sources.

(i) Incorporation by reference. The following sections of Part 55 of Act 451 of 1994, the Natural Resources and Environmental Protection Act are incorporated by reference.

(A) 324.5524 Fugitive dust sources or emissions, effective March 30, 1995.

(B) 324.5525 Definitions, effective March 30, 1995.

[FR Doc. 98-3177 Filed 2-9-98; 8:45 am]

BILLING CODE 6560-50-P

ENVIRONMENTAL PROTECTION AGENCY

40 CFR Part 52

[TX35-1-6168; FRL-5962-3]

Approval and Promulgation of Air Quality State Implementation Plans (SIP); Texas; Disapproval of Revisions to the State Implementation Plan

AGENCY: Environmental Protection Agency (EPA).

ACTION: Final rule.

SUMMARY: The EPA is taking final action on disapproval of SIP revisions Texas submitted for Regulation IV, 30 TAC Chapter 114, sections 114.1 "Maintenance and Operation of Air Pollution Control Systems or Devices

Used to Control Emissions from Motor Vehicles" and 114.5 "Exclusions and Exceptions" on February 24, 1989, September 6, 1990, and July 13, 1993.

The EPA is disapproving these revisions that relate to Statewide antitampering provisions and exemptions to antitampering provisions for motor vehicles or motor vehicle engine emission control systems. The EPA is taking final disapproval action because the State's antitampering rules are not consistent with the Clean Air Act (the Act), section 203(a)(3) and EPA's tampering prohibition as outlined in EPA's antitampering Enforcement Policy, Mobile Source Enforcement Memorandum No. 1A.

EFFECTIVE DATE: This action is effective as of March 12, 1998.

FOR FURTHER INFORMATION CONTACT: Mr. Paul Scoggins, Air Planning Section (6PD-L), EPA Region 6, 1445 Ross Avenue, Dallas, Texas 75202-2733, telephone (214) 665-7354 or via E-mail at scoggins.paul@epamail.epa.gov.

SUPPLEMENTARY INFORMATION:

I. Background

This document announces EPA's final action regarding disapproval of three revisions that relate to Statewide antitampering provisions and exemptions to antitampering provisions for motor vehicles or motor vehicle engine emission control systems. On February 24, 1989, September 6, 1990, and July 13, 1993, EPA received revisions to the Texas SIP for changes to Regulation IV, 30 TAC Chapter 114, sections 114.1 and 114.5, 114.5, and 114.1 and 114.5 respectively. In their regulations, Texas adopted specific measures restricting emission control equipment removal/modifications (antitampering) and exempting or providing exclusions for vehicles from antitampering requirements.

The Federal tampering prohibition for emission control equipment for motor vehicles and motor vehicle engines is contained in section 203(a)(3) of the Act, 42 U.S.C. 7522(a)(3). Section 203(a)(3)(A) of the Act prohibits "any person from removing or rendering inoperative any emission control device or element of design installed on or in a motor vehicle or motor vehicle engine prior to its sale and delivery to an ultimate purchaser" and prohibits "any person from knowingly removing or rendering inoperative any such device or element of design after such sale and delivery to the ultimate purchaser." Mobile Source Enforcement Memorandum No. 1A, dated June 25, 1974, provides guidance on what is a violation of section 203(a)(3).

The State revision, received February 24, 1989, made the following changes. Section 114.1 prohibits: (1) The removal of or render inoperative any system or device used to control emissions from a motor vehicle or motor vehicle engine or any part thereof; (2) specifies the conditions for the acceptable removal and/or installation of vehicle engines, catalytic converters, or other emission control components; (3) prohibits leasing, sale, or offer to sale motor vehicles that have tampered emission control equipment; (4) and finally, establishes sign posting requirements for prohibitions.

Section 114.5 exempts from the provisions of 114.1: (1) Dual-fuel conversions specified by the Department of Public Safety (DPS); (2) vehicles belonging to persons being transferred to a foreign country and specifies associated documentation requirements; (3) sales or offers for sale motor vehicles for wholesale transaction and for sales or trade-ins from an individual to a vehicle dealer; (4) Federal, State and local agencies that sell abandoned, confiscated, or seized vehicles and vehicle auction facilities if specific conditions are satisfied.

The State revision, received September 9, 1990, to section 114.5 exempts all dealer transactions that do not result in the sale of a tampered vehicle to an individual for operation on a public highway.

The State revision, received on July 13, 1993, made the following changes. Section 114.1 addresses the replacement or installation of aftermarket alternative fuel conversions equipment and any other system or device relating to emissions, safety concerns and antitampering. Section 114.5 specifies conditions for granting motor vehicle and motor vehicle engine exclusions from the provisions of section 114.1, deletes original text in section 114.5(c) to improve consistency with section 114.1, and redesignates original paragraphs. For further discussion, please refer to the proposal for this action (62 FR 48033, September 12, 1997).

II. Final Action

The EPA is taking final disapproval action on Texas SIP revisions for Texas Regulation IV, 30 TAC Chapter 114, sections 114.1 and 114.5, based on the following inconsistencies with the Clean Air Act and EPA's tampering prohibition. Section 114.1(b)(4) allows replacement or installation of any system or device (other than catalytic converters, engines and the conversion of the vehicle to alternative fuels, which are handled under separate subsections)

if: The system or device can be demonstrated to be at least as effective in reducing emissions as the original equipment. This rule does not provide how the above demonstration will be made nor the criteria for the demonstration. Section 114.5(a)(1) allows registered farm vehicles used primarily on a farm or ranch to remove or make inoperable the farm vehicles air pollution control system or device used to control emissions from the farm vehicle. This exemption is contrary to section 203(a)(3)(A) of the Act and EPA tampering prohibition as outlined in Memorandum No. 1A. Section 114.5(c) allows exclusion from tampering laws by petition to the State for danger to person or property. The EPA has never recognized any circumstances that merit removal of a catalytic converter or other emissions controls because of a fire hazard or other problem. Again, this is contrary to the Act and EPA tampering prohibition. In addition, section 114.1(b)(3) references a deleted section and section 114.1(e) allows dispensing of leaded gasoline if properly labeled. The Act banned the dispensing of leaded gasoline on January 1, 1996.

These inconsistencies and the basis of EPA's action were published as a proposed disapproval action on September 12, 1997, in the *Federal Register* (62 FR 48033). No comments were received during the public comment period.

Texas' statewide tampering prohibitions are part of the state SIP but are not required under section 179(a) of the Act. Even though there is a federal law which provides for EPA enforcement, many states do have such rules and use them successfully as enforcement tools for resolutions of consumer complaints involving tampered vehicles, deterrence of tampering, deterrence of selling tampered vehicles, and enforcement of tampering violations. Federal law in section 203(a) of the Act, which prohibits tampering, will continue to be in effect. Since State tampering rules are not required by the Act, this final disapproval action does not impose sanctions for failure to meet Act requirements.

Nothing in this action should be construed as permitting or allowing or establishing a precedent for any future request for revision to any State Implementation Plan. Each request for revision to the State Implementation Plan shall be considered separately in light of specific technical, economic, and environmental factors and in relation to relevant statutory and regulatory requirements.

III. Administrative Requirements

A. Executive Order (E.O.) 12866

The Office of Management and Budget has exempted this regulatory action from E.O. 12866 review.

B. Regulatory Flexibility Act

Under the Regulatory Flexibility Act, 5 U.S.C. 600 *et seq.*, EPA must prepare a regulatory flexibility analysis assessing the impact of any proposed or final rule on small entities. See 5 U.S.C. 603 and 604. Alternatively, EPA may certify that the rule will not have a significant impact on a substantial number of small entities. Small entities include small businesses, small not-for-profit enterprises, and government entities with jurisdiction over populations of less than 50,000.

The EPA's disapproval action of the State request under section 110 and subchapter I, part D of the Act does not affect any existing requirements applicable to small entities. Any preexisting Federal requirements remain in place after this final disapproval. Federal disapproval of the State submittal does not affect its State-enforceability. Moreover, EPA's final disapproval of the submittal does not impose any new Federal requirements. Therefore, EPA certifies that this final disapproval action does not have a significant impact on a substantial number of small entities because it does not remove existing requirements and impose any new Federal requirements.

C. Unfunded Mandates

Under section 202 of the Unfunded Mandates Reform Act of 1995, signed into law on March 22, 1995, EPA must prepare a budgetary impact statement to accompany any proposed or final rule that includes a Federal mandate that may result in estimated costs to State, local, or tribal governments in the aggregate; or to private sector, of \$100 million or more. Under section 205, EPA must select the most cost-effective and least burdensome alternative that achieves the objectives of the rule and is consistent with statutory requirements. Section 203 requires EPA to establish a plan for informing and advising any small governments that may be significantly or uniquely impacted by the rule.

The EPA has determined that this final disapproval action does not include a Federal mandate that may result in estimated costs of \$100 million or more to either State, local, or tribal governments in the aggregate, or to the private sector. This Federal final disapproval action imposes no new requirements. Accordingly, no

additional costs to State, local, or tribal governments, or to the private sector, result from this action.

D. Submission to Congress and the General Accounting Office

Under 5 U.S.C. 801(a)(1)(A) as added by the small business Regulatory Enforcement Fairness Act of 1996, EPA submitted a report containing this rule and the other required information to the U.S. Senate, the U.S. House of Representatives and the Comptroller General of the General Accounting Office prior to publication of this rule in today's *Federal Register*. This rule is not a "major rule" as defined by 5 U.S.C. section 804(2).

E. Petitions for Judicial Review

Under section 307(b)(1) of the Act, petitions for judicial review of this action must be filed in the United States Courts of Appeals for the appropriate circuit by April 13, 1998. Filing a petition for reconsideration by the Administrator of this final rule does not affect the finality of this rule for the purpose of judicial review nor does it extend the time within which a petition for judicial review may be filed, and shall not postpone the effectiveness of such rule or action. This action may not be challenged later in proceedings to enforce its requirements. See section 307(b)(2) of the Act.

List of Subjects in 40 CFR Part 52

Environmental protection, Air pollution control, Carbon monoxide, Hydrocarbons, Intergovernmental relations, Nitrogen dioxide, Ozone, Reporting and recordkeeping requirements.

Dated: January 26, 1998.

Jerry Clifford,

Acting Regional Administrator, Region VI.

Chapter I, title 40, of the Code of Federal Regulations is amended as follows:

PART 52—[AMENDED]

1. The authority citation for part 52 continues to read as follows:

Authority: 42 U.S.C. 7401 *et seq.*

Subpart SS—Texas

2. Section 52.2311 is added to read as follows:

§ 52.2311 Motor vehicle antitampering.

The State of Texas submitted revisions to the State Implementation Plan for 30 TAC Chapter 114, sections 114.1 "Maintenance and Operation of Air Pollution Control Systems or Devices Used to Control Emissions from

Motor Vehicles" and 114.5 "Exclusions and Exceptions" on February 24, 1989, and September 6, 1990, and July 13, 1993. The EPA disapproved these revisions that relate to Statewide antitampering provisions and exemptions to antitampering provisions for motor vehicles or motor vehicle engine emission control systems because the State's antitampering rules are not consistent with the Act, section 203(a)(3) and EPA's tampering prohibition as outlined in EPA's antitampering enforcement policy, Mobile Source Enforcement Memorandum No. 1A.

[FR Doc. 98-3175 Filed 2-9-98; 8:45 am]

BILLING CODE 6560-50-P

ENVIRONMENTAL PROTECTION AGENCY

40 CFR Part 52

[AZ 071-009; FRL-5957-4]

Approval and Promulgation of State Implementation Plans; Arizona—Maricopa County Ozone and PM₁₀ Nonattainment Areas

AGENCY: Environmental Protection Agency (EPA).

ACTION: Final rule.

SUMMARY: EPA is taking final action approving a State Implementation Plan (SIP) revision submitted by the State of Arizona on September 15, 1997, establishing Cleaner Burning Gasoline (CBG) fuel requirements for gasoline distributed in the Phoenix (Maricopa County) ozone nonattainment area. Arizona has developed these fuel requirements to reduce emissions of volatile organic compounds (VOC) and particulates (PM₁₀) in accordance with the requirements of the Clean Air Act (CAA). EPA is approving Arizona's fuel requirements into the Arizona SIP because either they are not preempted by federal fuels requirements, or to the extent that they are or may be preempted, EPA finds that the requirements are necessary for the Maricopa area to attain the national ambient air quality standards (NAAQS) for ozone and particulates. EPA intends to publish a separate document in the *Federal Register* approving Arizona's opt-out from the federal reformulated gasoline (RFG) program to be effective 90 days from the effective date of this EPA final action.

DATES: This final rule is effective on March 12, 1998.

ADDRESSES: Copies of the SIP revision and EPA's proposed and final

rulemakings are available for public inspection at EPA's Region IX office during normal business hours. Copies of the submitted rule revisions are available for inspection at the following locations:

Planning Office (AIR-2), Air Division, U.S. Environmental Protection Agency, Region IX, 75 Hawthorne Street, San Francisco, CA 94105.

Arizona Department of Environmental Quality, Office of Outreach and Information, First Floor, 3033 N. Central Avenue, Phoenix Arizona 85012.

A copy of this notice is also available on EPA Region IX's website at <http://www.epa.gov/region09>.

FOR FURTHER INFORMATION CONTACT: Karina O'Connor, Air Planning Office, AIR-2, Air Division, U.S. Environmental Protection Agency, Region IX, 75 Hawthorne Street, San Francisco, CA 94105, Telephone: (415) 744-1247.

SUPPLEMENTARY INFORMATION:

I. Clean Air Act Requirements

In determining the approvability of a SIP revision, EPA must evaluate the SIP revision for consistency with the requirements of the CAA and EPA regulations, as found in section 110 and part D of the CAA and 40 CFR part 51 (Requirements for Preparation, Adoption, and Submittal of Implementation Plans).

For SIP revisions addressing certain fuel measures, an additional statutory requirement applies. CAA section 211(c)(4)(A) prohibits state regulation respecting a fuel characteristic or component for which EPA has adopted a control or prohibition under section 211(c)(1), unless the state control is identical to the federal control. Section 211(c)(4)(C) provides an exception to this preemption if EPA approves the state requirements in a SIP. Section 211(c)(4)(C) states that the Administrator may approve preempted state fuel standards in a SIP:

... only if [s]he finds that the State control or prohibition is necessary to achieve the national primary or secondary ambient air quality standard which the plan implements. The Administrator may find that a State control or prohibition is necessary to achieve that standard if no other measures that would bring about timely attainment exist, or if other measures exist and are technically possible to implement, but are unreasonable or impracticable.

EPA's August 1997 Guidance on Use of Opt-in to RFG and Low RVP Requirements in Ozone SIPs gives further guidance on what EPA is likely to consider in making a finding of necessity.

Detailed discussions of the issues relating to federal preemption and the necessity finding are discussed more fully in the proposal for this final rule (62 FR 61942 (November 20, 1997)) and in section III below.

II. Background

Under the Clean Air Act Amendments of 1990, the Phoenix area was classified as a moderate nonattainment area for both ozone and PM₁₀. The moderate ozone attainment deadline was November 15, 1996; the moderate PM₁₀ attainment deadline was December 31, 1994. In 1997, the Phoenix area was reclassified as serious for ozone with an attainment deadline of no later than November 15, 1999. In 1996, the Phoenix area was reclassified as serious for PM₁₀ with an attainment deadline of no later than December 31, 2001.¹

On January 17, 1997, Governor Symington applied to EPA to include the Maricopa County ozone nonattainment area in the federal reformulated gasoline (RFG) program and the State submitted section 13 of HB 2001 to EPA as a SIP revision on April 29, 1997. Because this State fuel requirement established a control on Reid Vapor Pressure (RVP) of 7.0 psi, not identical to the federal fuel RVP requirements adopted under section 211(c)(1) authority applicable to the area (i.e., federal conventional gasoline RVP limit of 7.8 psi, federal phase I RFG RVP limit of 7.2 psi or federal phase II volatility limit of 7.8 psi), Arizona's fuel requirement was preempted under section 211(c)(4)(A) of the CAA. EPA approved Governor Symington's request to opt in to the federal RFG program on June 3, 1997. 62 FR 30260. EPA also published a direct final approval of Arizona's low RVP SIP revision on June 11, 1997. 62 FR 31734. In approving the RVP SIP revision, EPA found under section 211(c)(4)(C) that the State's fuel requirement is necessary for the Maricopa area to attain the NAAQS for ozone.

The State also enacted HB 2307 which authorized the establishment of a more stringent State reformulated gasoline program.²

In a September 12, 1997, letter, Russell Rhoades, Director, ADEQ,

¹ See 56 FR 56694 (November 6, 1991), CAA Sections 181(a)(1) and 188(c)(1), 62 FR 60001 (November 6, 1997) and CAA Section 181(a)(1), 61 FR 21372 (May 10, 1996) and CAA Section 188(c)(2).

² The State reformulated gasoline rules are codified in the ARS as section 41-2124. Section 41-2123 of HB 2307 also contains wintertime oxygenate requirements for fuels. The bill changed the effective dates of the oxygenate requirements from October 15 to November 15 through March 31 of each year.

requested that EPA approve the CBG Interim Rule as a revision to the Arizona SIP based in part on a waiver of preemption under CAA section 211(c)(4)(C). To allow the Arizona CBG program to substitute for the federal RFG program, on September 15, 1997, the State also submitted a separate letter to Administrator Browner, requesting to opt out of the federal RFG program, effective June 1, 1998, contingent upon EPA approval of the Arizona SIP revision and the associated waiver request. Upon publication of this final approval of CBG Interim Rule, EPA will publish a notice in the *Federal Register* approving Arizona's opt-out from the federal RFG program.

For a more detailed discussion of the CBG program and EPA's evaluation of it, and the history of fuels regulation in Arizona, see EPA's proposed approval at 62 FR 61942.

III. Summary of Proposal

A. Arizona CBG Fuel Program

The State CBG fuel program for the Maricopa area establishes limits on gasoline properties and gasoline emission standards which will reduce emissions of volatile organic compounds (VOCs), oxides of nitrogen (NO_x), carbon monoxide (CO) and particulates (PM). Under the program, a variety of different fuels will be able to meet the fuel standards during different implementation periods. These emissions reductions will help the Maricopa area attain the NAAQS for both ozone and particulates.

On November 22, 1997, EPA proposed to approve the CBG SIP revision submitted by the State of Arizona for the Phoenix ozone and PM₁₀ nonattainment areas under section 110(k)(3) of the CAA as meeting the requirements of section 110(a) and part D. The proposed approval was based upon the finding that the CBG SIP revision was consistent with the CAA and EPA regulations and that the various CBG requirements are either not preempted by federal fuel requirements or are necessary for the Phoenix nonattainment area to attain the ozone and PM₁₀ NAAQS. Issues relating to federal preemption and the necessity finding are discussed further below. See also 62 FR 61942.

B. Section 211(c)(4)

1. Federal Preemption

As discussed above, CAA section 211(c)(4)(A) preempts certain state fuel regulations by prohibiting a state from prescribing or attempting to enforce any control or prohibition respecting any characteristic or component of a fuel or fuel additive for the purposes of motor

vehicle emission control, if the Administrator has prescribed under section 211(c)(1), a control or prohibition applicable to such characteristic or component of the fuel or fuel additive, unless the state prohibition is identical to the prohibition or control prescribed by the Administrator.

The CBG Interim Rule establishes three types of gasoline standards. For 1998, the requirements for CBG Types 2 and 3 gasoline³ apply. In addition, all Arizona CBG must meet specified fuel property limits for that year.⁴ For 1999 and beyond, the requirements for CBG Types 1 and 2 gasoline would apply. In addition, all Arizona CBG would have to meet the fuel property limits specified for that time period.⁵ These proposed types of gasoline include performance standards as well as requirements for specific fuel parameters. EPA's analysis in the proposal of preemption addressed the following standards in the CBG Interim Rule: performance standard for NO_x (under gasoline Types 1, 2, and 3); parameter specifications for sulfur, olefins, and aromatic HC (under gasoline Type 2); performance standard for VOC (under gasoline Types 1 and 3); parameter specification for oxygen content (under gasoline Types 1 and 3); performance standard for HC (under Type 2); and parameter specifications for oxygen, aromatic HC, T50, and T90 (under gasoline Type 2).⁶

To determine whether a state fuel requirement is preempted by a federal requirement, EPA compares the applicable federal fuel requirements in the area with the proposed state fuel requirements. For the purposes of this analysis, the federal fuel requirement in the Phoenix ozone nonattainment area is federal conventional gasoline. While Arizona has opted into the federal RFG program for the 1997 season, the State has requested to opt out of the program before the State CBG requirements would apply. Once the State has opted out of the federal RFG program, the applicable federal requirements would be those for conventional gasoline. The federal requirements for conventional gasoline include a NO_x performance standard. CBG Types 1 and 3 also

contain a NO_x performance standard, so the CBG NO_x performance standard is preempted. The CBG Interim Rule would allow refiners to meet the requirements for Type 2 gasoline in lieu of the requirements for CBG Type 1 or 3 gasoline. Whether the specifications for CBG Type 2 are preempted is less clear. The CBG Type 2 specifications include performance standards for NO_x and requirements for the fuel parameters sulfur, olefins and aromatic HCs. The federal conventional gasoline standards do not include requirements for these specific parameters. However, refiners are required to use an emissions performance model that determines NO_x performance based in part on these fuel parameters.

As stated in the proposal, in this rulemaking, EPA does not need to determine whether these types of State fuel requirements are preempted under section 211(c)(4)(A) prior to acting on the proposed revision to the Arizona SIP. If the sulfur, olefins and aromatic HC requirements are not preempted, there is no bar to EPA approving them as a SIP revision. If they are preempted, section 211(c)(4)(C) would allow EPA to approve each requirement in a SIP if EPA determines that such controls are necessary to achieve the NAAQS that the SIP implements. EPA can approve such a State SIP provision as necessary if it finds that no other measures that would bring about timely attainment exist, or that other measures exist but are unreasonable or impracticable. Thus, if a State shows that the reductions that would be produced by the State's NO_x performance standard are necessary under section 211(c)(4)(C) to achieve a NAAQS, EPA could approve the NO_x performance standard as a SIP revision. Under Type 1 or 3 CBG, refiners would obtain NO_x reductions through a NO_x performance standard, and under Type 2 CBG, refiners would obtain comparable NO_x reductions through sulfur, olefins and aromatic HC requirements. If EPA finds the NO_x reductions produced by the NO_x performance standard under CBG Types 1 and 3 to be necessary, then the comparable reductions produced by the alternative of CBG Type 2 gasoline would also be necessary. Thus, based on EPA's finding, discussed below and in the proposal, that NO_x reductions are necessary under section 211(c)(4)(C), EPA proposed to approve the sulfur, olefins and aromatic HC requirements as well.

The CBG Interim Rule also requires refiners to meet a VOC performance standard and oxygen content standard (under CBG Types 1 and 3 gasoline); or a HC performance standard and oxygen

content standard; or oxygen, T50, T90, and aromatic HC requirements (under CBG Type 2 gasoline).⁷ Federal conventional gasoline requirements do not include a VOC or HC performance standard or controls on these specific parameters. However, refiners are required to meet summertime volatility limits, and are required to use an emissions performance model that determines VOC performance based in part on the same fuel parameters as those used in the CBG Interim Rule. In this rulemaking, EPA does not need to determine whether these types of state fuel requirements are preempted under section 211(c)(4)(A) if EPA finds that these fuel requirements are necessary for the Phoenix nonattainment area to meet the ozone NAAQS. Of course, if these requirements are not preempted, there is no bar to approving them as a SIP revision. If they are preempted, section 211(c)(4)(C) would allow EPA to approve each requirement in a SIP if EPA determines that such controls are necessary to achieve the NAAQS that the SIP implements.

Each type of CBG gasoline would reduce VOC emissions. Under Type 1 or 3 CBG, refiners would obtain VOC reductions through a VOC performance standard and oxygen content standard, and under Type 2 CBG, refiners would obtain comparable VOC reductions through either a HC performance standard and oxygen content standard; or through oxygen, T50, T90, and aromatic HC requirements. If EPA finds the VOC reductions produced by the VOC performance standard and oxygen content standard under CBG Types 1 and 3 to be necessary, then the comparable reductions produced by either of the alternatives of CBG Type 2 gasoline would also be necessary. Thus, based on EPA's finding, discussed in the proposal and below, that VOC reductions are necessary under section 211(c)(4)(C), EPA proposed to approve the HC performance standard; and the oxygen, T50, T90, and aromatic HC requirements as well.

Arizona has already demonstrated that its 7.0 psi RVP requirement is necessary under section 211(c)(4)(C) to meet the ozone NAAQS in the Phoenix area.⁸ Compliance with either the VOC performance standard and oxygen content standard; or the HC performance standard and the oxygen standard; or the oxygen, T50, T90, and aromatic HC requirements would produce some additional VOC

⁷ Under gasoline Type 2 using the Predictive model, refiners are required to meet the oxygen content standard only during the winter months.

⁸ See 62 FR 31734 (June 11, 1997).

³ Under the CBG program, a variety of different fuels will be able to meet the fuel standards during different implementation periods. The fuel types, designations and implementation schedule are described in the proposal at 62 FR 61942-64923.

⁴ AAC R20-2-751.01.A.

⁵ AAC R20-2-751.A.

⁶ The CBG Type 2 gasoline allows refiners to comply with a group of fuel parameter specifications or to meet performance standards using the Predictive Model and set individual alternative fuel parameter specifications.

reductions beyond those produced by the 7.0 psi RVP requirement. As with the NO_x performance standard and the alternative fuel parameter requirements discussed above, refiners would obtain comparable VOC reductions through either the VOC performance standard and oxygen content standard; the HC performance standard and the oxygen content standard, or the oxygen, T50, T90, and aromatic HC requirements. Thus, if EPA finds the VOC reductions produced by the VOC performance standard and oxygen content standard under CBG Type 1 and 3 gasoline to be necessary, then the comparable emissions reductions produced by the alternative of CBG Type 2 gasoline would also be necessary. EPA proposed to approve the VOC performance standard; the HC performance standard and the oxygen content standard; and the oxygen, T50, T90, and aromatic HC requirements because either they are not preempted under section 211(c)(4)(C) or to the extent that they are or may be preempted, EPA proposed, as discussed below, that they are necessary and hence approvable under section 211(c)(4)(C).

2. Finding of Necessity

EPA proposed to find that the CBG NO_x performance standards and the sulfur, olefins and aromatic HC requirements are necessary for the Phoenix PM₁₀ nonattainment area to meet the PM₁₀ NAAQS; and that the CBG VOC performance standard and oxygen content standard; the HC performance standard and the oxygen content standard; and the oxygen, T50, T90, and aromatic HC requirements are necessary for the Phoenix ozone nonattainment area to meet the ozone NAAQS.

In the proposal, EPA explained its reasoning that to make a determination that the CBG requirements are necessary, it must consider whether there are other reasonable and practicable measures available that would produce sufficient emissions reductions to attain the ozone and PM₁₀ standards without implementation of the CBG requirements. In considering other measures for the purpose of demonstrating necessity under section 211(c)(4)(C), EPA agreed in the proposal that Arizona need not submit an evaluation of alternative fuels measures. See the proposed approval of the CBG SIP revision at 62 FR 61942 and the response to comments below for a more detailed discussion of this issue. Thus, to determine whether the State gasoline VOC performance standards (and the HC performance standards; and the oxygen, T50 and T90 requirements) are

necessary to meet the ozone NAAQS, EPA must consider whether there are other reasonable and practicable non-fuel measures available to produce the needed emission reductions for ozone control.

IV. Response to Public Comments on the Proposal

EPA received four comment letters in response to its November 22, 1997 proposal. Comments were received from the Arizona Department of Environmental Quality and three gasoline marketers in Maricopa County: Chevron Products Company, Mobil Oil Corporation, and Stancil & Co. representing Navajo Refining Company. EPA wishes to express its appreciation to each of these individuals and organizations for taking the time to comment on the proposal. All of the commenters supported approval of the CBG SIP revision, however two of the commenters also raised technical concerns to which EPA responds below.

Comment: One commenter, while urging EPA to approve the SIP revision, indicated that they disagreed with the CBG rule being portrayed as an important control measure for PM₁₀ in the proposed rulemaking. The commenter noted that the emission reductions associated with the NO_x performance standard are small in comparison to the total amount of the PM₁₀ inventory.

Response: EPA agrees with the commenter that the associated particulate emission reductions are only a small part of the entire inventory. However, for the purposes of finding necessity under section 211(c)(4)(C), the CAA does not impose a legal criterion for approval of a measure that depends on the magnitude of reductions that the measure would achieve, and it is not critical whether the emission reductions associated with the measure are large or small. Rather, section 211(c)(4)(C) focuses on whether there are other measures available that would achieve attainment of a NAAQS. As described in the proposal for this final rule (62 FR 61942, 61946), the information submitted by ADEQ indicates that even with implementation of all measures that are reasonable and practicable in light of the availability of the fuel control, the state cannot fill the projected shortfall in emission reductions needed for attainment of the PM₁₀ NAAQS. Also, while the effect of the NO_x performance standard on PM₁₀ levels is small, the NO_x performance standard will reduce PM₁₀. Hence, EPA is today finding that the NO_x performance standards in the CBG requirements are necessary for

attainment of the PM₁₀ standard, and EPA is approving them as a revision to the Arizona SIP for the Phoenix PM₁₀ nonattainment area.⁹

Comment: One commenter argued that the April 1—October 31 ("summertime") minimum oxygen requirement for the RFG-type fuel (CBG types 1 and 3 gasoline) should not be approved as part of the CBG regulations. The commenter stated that the federal conventional gasoline requirements do not include a summertime oxygen requirement, so the State of Arizona is preempted from a summertime oxygen content standard. The commenter added that if the State were preempted, the State must make the necessity showing for a waiver under section 211(c)(4)(C).

Response: As stated above, EPA believes it does not need to address in today's action whether a State requirement for oxygen is preempted under section 211(c)(4)(A). If the standard is not preempted, there is no bar to EPA approving it in the SIP revision. If the State meets the requirement under section 211(c)(4)(C) by showing that the requirement is necessary to meet the ozone NAAQS, EPA does not need to address whether a summertime oxygen requirement is preempted. If the State demonstrates that it needs a quantity of VOC reductions during the ozone season to reach attainment, that there are no other reasonable and practicable measures available to produce all of those reductions, and that the fuel (Type 1 and Type 3 CBG gasoline requirements for VOC performance standard and oxygen content standard) will produce additional VOC reductions during the ozone season, the State has shown necessity for the fuel requirement. EPA finds that Arizona has made this showing, as discussed elsewhere in this notice and the proposal at 62 FR 61942.

In addition, EPA notes that the commenter is not accurate in stating that because the federal conventional gasoline requirements do not include a summertime oxygen content requirement the State is preempted from adopting such a requirement. A state is preempted from adopting a control or prohibition respecting a fuel characteristic or component where EPA has prescribed under section 211(c)(1) a control or prohibition applicable to such characteristic or component, unless the state control or prohibition is identical to the federal control or prohibition. Thus, where there is no federal control

⁹In its September 12, 1997 letter, ADEQ submitted the CBG Interim Rule as a revision to the Arizona ozone SIP only. However, on January 21, 1998 the State also submitted the rule as a revision to the Arizona PM₁₀ SIP.

or prohibition on a fuel characteristic or component, a state is not preempted from adopting regulations respecting that characteristic or component. As noted above, EPA has not determined whether the Arizona fuel requirement is preempted under this provision.

Comment: This commenter further argued that the CBG summertime oxygen requirement is both unreasonable and impracticable and therefore not necessary to meet the ozone NAAQS. The commenter argued that the intent of the Clean Air Act is that all non-fuel measures with similar or lesser cost effectiveness must be implemented prior to fuel control measures. The commenter asserted that the State had failed to address the cost-effectiveness or justification of this measure versus other non-fuel control measures not implemented, such as controls on stationary sources and full implementation of an inspection and maintenance program for vehicles.

Response: Section 211(c)(4)(C) provides that EPA can approve an otherwise preempted state fuel control only if there are no other reasonable and practicable measures available to achieve the NAAQS. Thus, EPA is directed to consider not whether the state fuel control at issue is reasonable and practicable, but whether other control measures are reasonable and practicable. If the state fuel control did not reduce emissions, EPA could not find it necessary to achieve a NAAQS, but the CAA does not otherwise direct EPA to assess the reasonableness and practicability of the state's chosen control measure. EPA believes that in determining whether other ozone control measures are unreasonable or impracticable, reasonableness and practicability should be determined in comparison to the fuel measure that the state is proposing to adopt. This is not an abstract consideration of whether the other measures are reasonable or practicable, but rather a consideration of whether it would be reasonable or practicable to require such other measures in light of the potential availability of the preempted state fuel control. Thus, the relative cost-effectiveness of other control measures would be one factor that EPA would consider in determining whether they are reasonable and practicable, but it would not necessarily be the only or deciding factor. See EPA's August 1997 "Guidance on Use of Opt-in to RFG and Low RVP Requirements in Ozone SIPs" for further guidance on what EPA considers in making a finding of necessity.

Moreover, EPA does not believe it is appropriate or necessary to second

guess the State's choice of this particular fuel control by inquiring whether the State could have limited the oxygen content standard to the winter season rather than applying it year-round. Essentially, the commenter is suggesting that a wintertime oxygen content requirement is a reasonable and practicable alternative control measure and that EPA should evaluate that measure before concluding that there are not sufficient reasonable and practicable other control measures available to achieve the NAAQS. As discussed in the proposal, EPA interprets the reference to other measures that must be evaluated as generally not encompassing other state fuels measures. The Agency believes that the Act does not call for a comparison between state fuels measures to determine which measures are unreasonable or impracticable, but rather section 211(c)(4) is intended to ensure that a state resorts to a fuel measure only if there are no available practicable and reasonable non-fuels measures. This interpretation minimizes the burden on the oil industry of different state fuel measures where non-fuel measures are available, and thereby satisfies one of the underlying purposes of section 211(c)(4), but where the state must turn to a fuel measure, it gives the state flexibility to choose whatever particular fuel measure best suits its needs. Under this interpretation, EPA retains the ability not to approve a state fuel measure that is grossly overburdensome, however, because the state must show that whatever fuel measure it selects is necessary to achieve needed emissions reductions. Thus, in demonstrating that measures other than requiring CBG gasoline are unreasonable or impracticable, Arizona need not address the reasonableness or practicability of other possible state fuel measures, such as a wintertime only oxygen content standard.

Arizona must still demonstrate that its chosen fuel control measure achieves emissions reductions necessary for attainment of a NAAQS, which is discussed below and in the proposal.

With regard to the other measures identified by the commenter, Arizona believes its I/M program is as stringent as possible. EPA has been working with ADEQ over the last year to improve its I/M program due to problems with preconditioning. As discussed further below, current modeling¹⁰ by ADEQ

¹⁰ Arizona completed the Reanalysis of the Metropolitan Phoenix Voluntary Early Ozone Plan (REOP) modeling analysis in October of 1997. This modeling analysis indicated that a 23 percent reduction in ozone values was needed to reach attainment. The total impact of all control measures

indicates that a large reduction in ozone precursors is needed to attain the ozone standard. Previous modeling analysis of a full I/M 240 program indicates that the associated emission reductions, combined with all other reasonable and practicable measures are significantly below this amount. The current proposed I/M program includes an alternative test cycle which will result in improved throughput of the I/M 240 test. EPA has informally given the alternative program conditional approval. We anticipate, that with the collection of additional data during the summer of 1998, that the program will be granted full approval.

Regarding stationary measures, the State has provided additional preliminary modeling¹¹ that indicates that Phoenix needs to achieve substantial percent reductions in both VOCs and NO_x in order to reach attainment in 1999, the attainment deadline for serious areas. The State believes that even if it implements all possible stationary source requirements (in addition to those stationary source measures currently in place), it will still need additional reductions to achieve these reductions and reach attainment. For example, the REOP modeling analysis indicates that stationary point source emissions contribute only 4.5 percent and stationary area source emissions contribute only 20 percent of the total VOC emission inventory in 1999. Stationary point sources contribute 7 percent and stationary area source contribute 3.6 percent of the total NO_x emissions in 1999. Based on all the evidence available, even with the elimination of all of these stationary source emissions (which is not technically feasible), substantial additional emission reductions above 25 percent will be needed to reach attainment by 1999.

Comment: One commenter stated that ADEQ used a flawed analysis in its attempt to show that non-winter minimum-oxygen control is necessary for ozone attainment by calculation of an "equivalent" VOC impact. The commenter argues that ADEQ's inaccurate analysis resulted in an overstatement of the VOC emissions impact of a non-winter oxygen content control.

Response: EPA believes that this commenter is referencing ADEQ's

included in that analysis on ozone values was 4.4 percent, significantly below the 23 percent needed to reach attainment. Additional analysis of this modeling was completed in November of 1997, indicating that emission reductions of ozone precursors of at least 70 percent are needed to attain the one-hour ozone standard.

¹¹ See footnote 10

discussion and analysis regarding the relationship between carbon monoxide (CO) reductions and VOC reductions. ADEQ stated in its SIP submittal that one comment regarding Arizona's proposed CBG rule challenged the summertime oxygen content standard. Thus, ADEQ developed an analysis of the potential impact of preemption of a State oxygen content standard on ozone attainment. ADEQ stated that because oxygenation of gasoline reduces CO emissions and CO is an ozone precursor, it was determined that preemption of the oxygen content standard would reduce the potential ozone reduction benefits of the Arizona CBG program.¹²

EPA has reviewed ADEQ's analyses¹³ and believes that these analyses are insufficient to show that a summertime oxygen content gasoline requirement is necessary for Phoenix to achieve the ozone NAAQS. EPA believes more in-depth analysis would need to be done by EPA, states, and industry before EPA could make any conclusions on this issue. Nonetheless, EPA believes ADEQ does not need this analysis to show that the year-round oxygen content requirement is necessary under section 211(c)(4)(C) to meet the ozone NAAQS.

As stated above, if EPA finds the VOC reductions produced by the VOC performance standard and oxygen content standard under CBG Types 1 and 3 to be necessary, then the comparable reductions produced by either of the alternatives of CBG Type 2 gasoline would also be necessary. In today's action EPA is finding that VOC reductions are necessary under section 211(c)(4)(C) and is approving the VOC performance standard (and oxygen content standard); the HC performance standard (and the oxygen content standard); and the oxygen, T50, T90, and aromatic HC requirements because either they are not preempted under section 211(c)(4)(C) or to the extent that they are or may be preempted, they are necessary and hence approvable under section 211(c)(4)(C).

Arizona has already demonstrated that its 7.0 psi RVP requirement is necessary under section 211(c)(4)(C) to meet the ozone NAAQS in the Phoenix area.¹⁴ Compliance with the VOC performance standard and oxygen content standard (required by CBG gasoline types 1 and 3) would produce

some additional VOC reductions beyond those produced by the 7.0 psi RVP requirement. ADEQ's modeling shows that federal RFG would provide additional reductions of 8 percent over a baseline fuel of conventional gasoline with a 7.0 RVP requirement. In addition, EPA's complex model indicates that an increase in oxygen weight percent leads to a reduction in total VOC emissions.¹⁵ Refiners would also obtain comparable VOC reductions through the HC performance standard, or the oxygen, T50, T90, and aromatic HC requirements. Thus, EPA is finding in today's action that the VOC reductions produced by the VOC performance standard and oxygen content standard under CBG Type 1 and 3 gasoline are necessary; and the comparable emissions reductions produced by the alternative of CBG Type 2 gasoline are also necessary.

V. Action

EPA has evaluated the submitted SIP revision and has determined that it is consistent with the CAA and EPA regulations. EPA has also found that the various CBG requirements are either not preempted by federal fuel requirements or are necessary for the Phoenix nonattainment area to attain the ozone and PM₁₀ NAAQS, pursuant to the CAA. Therefore, EPA approves the Arizona CBG Interim Rule into the Arizona SIP for the Phoenix ozone and PM₁₀ nonattainment areas under section 110(k)(3) of the CAA as meeting the requirements of section 110(a) and part D.

Nothing in this action should be construed as permitting or allowing or establishing a precedent for any future implementation plan. Each request for revision to the state implementation plan shall be considered separately in light of specific technical, economic, and environmental factors and in relation to relevant statutory and regulatory requirements.

VI. Administrative Requirements

A. Executive Order 12866

The Office of Management and Budget (OMB) has exempted this regulatory action from E.O. 12866 review.

B. Regulatory Flexibility Act

Under the Regulatory Flexibility Act, 5 U.S.C. 600 *et seq.*, EPA must prepare a regulatory flexibility analysis assessing the impact of any proposed or final rule on small entities. 5 U.S.C. 603 and 604. Alternatively, EPA may certify that the rule will not have a significant impact on a substantial number of small

entities. Small entities include small businesses, small not-for-profit enterprises, and government entities with jurisdiction over populations of less than 50,000.

This final rule will not have a significant impact on a substantial number of small entities because this federal action authorizes and approves into the Arizona SIP requirements previously adopted by the State, and imposes no new requirements. Therefore, I certify that it does not have a significant impact on any small entities affected. Moreover, due to the nature of the Federal-State relationship under the CAA, preparation of a flexibility analysis would constitute Federal inquiry into the economic reasonableness of state action. The Clean Air Act forbids EPA to base its actions concerning SIPs on such grounds. *Union Electric Co. v. U.S. EPA*, 427 U.S. 246, 255-66 (1976); 42 U.S.C. 7410(a)(2).

C. Unfunded Mandates

Under Section 202 of the Unfunded Mandates Reform Act of 1995 ("Unfunded Mandates Act"), signed into law on March 22, 1995, EPA must prepare a budgetary impact statement to accompany any proposed or final rule that includes a Federal mandate that may result in estimated costs to State, local, or tribal governments in the aggregate; or to private sector, of \$100 million or more. Under Section 205, EPA must select the most cost-effective and least burdensome alternative that achieves the objectives of the rule and is consistent with statutory requirements. Section 203 requires EPA to establish a plan for informing and advising any small governments that may be significantly or uniquely impacted by the rule.

EPA has determined that this action promulgated does not include a Federal mandate that may result in estimated costs of \$100 million or more to either State, local, or tribal governments in the aggregate, or to the private sector, in any one year. This Federal action authorizes and approves requirements previously adopted by the State, and imposes no new requirements. Accordingly, no additional costs to State, local, or tribal governments, or to the private sector, will result from this action.

D. Submission to Congress and the General Accounting Office

Under 5 U.S.C. 801(a)(1)(A) as added by the Small Business Regulatory Enforcement Fairness Act of 1996, EPA submitted a report containing this rule and other required information to the U.S. Senate, the U.S. House of

¹² ADEQ Technical Support Document at page 7. This analysis is contained in appendices K and L to the Technical Support Document.

¹³ Appendix K, entitled CO reductions and equivalent VOC reductions from an increase in Gasoline Oxygen Content and Appendix L, entitled Ozone sensitivity to CO expressed in relation to VOC.

¹⁴ See 62 FR 31734 (June 11, 1997).

¹⁵ 40 CFR 80.45(c)(1) (i) and (ii)

Representatives and the Comptroller General of the General Accounting Office prior to publication of the rule in today's Federal Register. This rule is not a "major" as defined by 5 U.S.C. 804(2).

E. Petitions for Judicial Review

Under section 307(b)(1) of the Clean Air Act, petitions for judicial review of this action must be filed in the United States Court of Appeals for the appropriate circuit by April 13, 1998. Filing a petition for reconsideration by the Administrator of this final rule does not affect the finality of this rule for the purposes of judicial review nor does it extend the time within which a petition for judicial review may be filed, and shall not postpone the effectiveness of such rule or action. This action may not be challenged later in proceedings to enforce its requirements. (See section 307(b)(2).)

List of Subjects in 40 CFR Part 52

Environmental protection, Air pollution control, Hydrocarbons, Volatile organic compounds, Nitrogen oxides, Particulate matter, Incorporation by reference, Intergovernmental relations, Ozone, PM₁₀, Reporting and recordkeeping requirements.

Note: Incorporation by reference of the State Implementation Plan for the State of Arizona was approved by the Director of the Federal Register on July 1, 1982.

Dated: January 23, 1998.

Felicia Marcus,

Regional Administrator, Region IX.

Part 52, chapter I, title 40 of the Code of Federal Regulations is amended as follows:

PART 52—[AMENDED]

1. The authority citation for part 52 continues to read as follows:

Authority: 42 U.S.C. 7401 *et seq.*

Subpart D—Arizona

2. Section 52.120 is amended by adding paragraph (c)(89) and (c)(90) to read as follows:

§ 52.120 Identification of plan.

* * * * *

(c) * * *

(89) Plan revisions were submitted on September 12, 1997 by the Governor's designee.

(i) Incorporation by reference

(A) Arizona Cleaner Burning Gasoline Interim rule submitted as a revision to the Maricopa County Ozone Nonattainment Area Plan, adopted on September 12, 1997.

(90) Plan revisions were submitted on January 21, 1998 by the Governor's designee.

(i) Incorporation by reference.

(A) Arizona Cleaner Burning Gasoline Interim rule submitted as a revision to the PM-10 Maricopa County State Implementation Plan, adopted on September 12, 1997.

* * * * *

[FR Doc. 98-3327 Filed 2-9-98; 8:45 am]

BILLING CODE 5580-50-P

ENVIRONMENTAL PROTECTION AGENCY

40 CFR Part 52

[TX82-1-7336b; FRL-5962-5]

Approval and Promulgation of State Implementation Plan, Texas: 15% Rate-of-Progress Plan, 1990 Emission Inventory, Motor Vehicle Emission Budget, and Contingency Plan for the Beaumont/Port Arthur Ozone Nonattainment Area

AGENCY: Environmental Protection Agency (EPA).

ACTION: Direct final rule.

SUMMARY: In this action, EPA is approving a revision to the Texas State Implementation Plan (SIP) for the Beaumont/Port Arthur ozone nonattainment area for the purpose of satisfying the 15% rate-of-progress requirements of the Clean Air Act (Act) as amended in 1990, which will aid in ensuring the attainment of the National Ambient Air Quality Standard (NAAQS) for ozone. The EPA is also approving the area's associated Motor Vehicle Emission Budget (MVEB).

In addition, EPA is approving revisions to the 1990 base year emissions inventory and the contingency plan for this area.

This action also replaces the proposed limited approval/limited disapproval of the Beaumont/Port Arthur 15% Plan and Contingency Plan published on January 29, 1996. The May 22, 1997 (62 FR 27964), limited approval of the Volatile Organic Compound (VOC) control measures continues in effect.

DATES: This direct final rule document is effective April 13, 1998, unless adverse comments are received by March 12, 1998. If the effective date is delayed, timely notice will be published in the Federal Register.

ADDRESSES: Written comments should be addressed to Mr. Thomas H. Diggs, Chief, Air Planning Section (6PD-L), at the EPA Regional Office listed below. Copies of the documents relevant to this

final action are available for public inspection during normal business hours at the following locations. Interested persons wanting to examine these documents should make an appointment with the appropriate office at least 24 hours before the visiting day.

Environmental Protection Agency, Region 6, Multimedia Planning and Permitting Division, 1445 Ross Avenue, suite 700, Dallas, Texas 75202-2733.

Texas Natural Resource Conservation Commission (TNRCC), 12100 Park 35 Circle, Building F, Austin, Texas 78753.

Documents which are incorporated by reference are available for public inspection at the Air and Radiation Docket and Information Center, Environmental Protection Agency, 401 M Street, SW., Washington, DC 20460. **FOR FURTHER INFORMATION CONTACT:** Mr. Eaton R. Weiler, of the EPA Region 6 Air Planning Section at the above address, telephone (214) 665-7242.

SUPPLEMENTARY INFORMATION:

I. Background

A. Clean Air Act Requirements

Section 182(b)(1) of the Act as amended in 1990 requires all ozone nonattainment areas classified as moderate and above to submit a SIP revision by November 15, 1993, which describes, in part, how these areas will achieve an actual reduction in VOC emissions of at least 15 percent, from a 1990 baseline, during the first six years after enactment of the Act (November 15, 1996). The Act also sets limitations on the creditability of certain types of reductions. Specifically, states cannot take credit for reductions achieved by Federal Motor Vehicle Control Program (FMVCP) measures (new car emissions standards) promulgated prior to 1990, or for reductions resulting from requirements to lower the Reid Vapor Pressure (RVP) of gasoline promulgated prior to 1990. Furthermore, the Act does not allow credit for corrections to Vehicle Inspection and Maintenance Programs (I/M), or corrections to Reasonably Available Control Technology (RACT) rules as these programs were required prior to 1990. Emissions and emissions reductions shall be calculated on a typical weekday basis for the "peak" 3-month ozone period (generally June through August).

In addition, section 172(c)(9) of the Act requires that contingency measures be included in the plan revision to be implemented if reasonable further progress is not achieved, or if the standard is not attained.

In Texas, the Beaumont/Port Arthur ozone nonattainment area is classified as "moderate" and is subject to the

section 182(b)(1) 15% rate-of-progress requirements. The Beaumont/Port Arthur ozone nonattainment area is comprised of the following counties: Orange, Jefferson, and Hardin. The 15 percent VOC emissions reduction required by November 15, 1996, is defined within this document as "rate-of-progress" (ROP). The SIP revision which delineates the plan for achieving the emissions reductions is defined in this document as the "15% ROP Plan."

B. Previous 15 Percent Rate of Progress SIP revisions

Texas first adopted measures for the 15% ROP Plans and the required contingency measures for the four nonattainment areas of Dallas/Fort Worth, Houston/Galveston, El Paso, and Beaumont/Port Arthur in two phases. Phase I was submitted to EPA on November 13, 1993, and contained measures achieving the bulk of the required reductions in each of the nonattainment areas. Phase II was submitted May 9, 1994. The Phase II submittal was to make up the shortfall in reductions not achieved by the Phase I measures. The combination of the Phase I and Phase II measures was ruled administratively complete by EPA on May 12, 1994.

The EPA analyzed the November 13, 1993, and May 9, 1994, submittals and determined that the measures included in the plan did not achieve the required amount of reductions. Among other reasons, there was a shortfall because the I/M program relied on reductions in the plans which had subsequently been repealed by the State. On January 29, 1996 (61 FR 2751), EPA published a proposed limited approval/limited disapproval of the 15% Plans included in the November 13, 1993, and May 9, 1994, submittal.

The EPA also proposed a limited approval of the measures that were included with the plans because they resulted in a strengthening of the SIP. For a complete discussion of the deficiencies in the State's plans, please see the January 29, 1996, Federal Register document.

C. Current 15 Percent SIP Revision

The Governor of Texas submitted revisions to the 15% ROP Plans for Beaumont/Port Arthur, Dallas/Fort Worth, El Paso and Houston/Galveston areas in a letter dated August 9, 1996. The SIP submittal also included revisions to the 1990 Base Year Inventory, El Paso section 818 analysis, the Post 96 ROP Plan for Houston, and the Employee Commute Options. In this Federal Register, EPA is taking action on only the Emission Inventory, 15%

ROP Plan, Contingency measures, and MVEB for the Beaumont/Port Arthur area. The EPA is taking no action on the other portions of the August 23, 1996, submittal in this Federal Register, nor on any plans for the Dallas/Fort Worth, El Paso and Houston areas. The other portions of the Governor's SIP submittal will be finalized in separate Federal Register actions.

II. Analysis of the Submittal

A. General

Texas has made the following changes to address the shortfalls that were identified in the January 29, 1996, limited approval/limited disapproval proposed action. First, Texas made several revisions to its emissions estimates. These revisions were based on more recent information or source surveys. From these studies, Texas concluded that, in some instances, better estimates of emissions were available based on locally derived emission factors rather than defaults based on national data. Second, these same studies resulted, in some instances, in lower projections of emissions in 1996 resulting in less growth to be offset. Finally, by better segregating the emission points that were subject to specific rules, Texas identified additional emission reductions from measures in the original 15% Plan. The EPA believes that the revisions to the Emission Inventory and Growth Projections eliminate the shortfall identified in the January 29, 1996, limited disapproval/limited approval proposed action.

B. Emission Inventory Revisions

The EPA approved the Texas 1990 base year inventory on November 8, 1994 (59 FR 55586). In the August 23, 1996 SIP submittal, Texas included revisions to the approved VOC inventory. The revisions have been made based on more recently available information from source surveys and other methods. Much of the information was developed as part of bottom-up surveys of area source categories performed as part of the 1993 intensive ozone study in the Houston and Beaumont. This study, called the Coastal Oxidant Assessment for Southeast Texas (COAST), included a study of area source emissions. Traditional area source emission inventory techniques use national or state level statistics for the level of activity of a source category. For example, gallons of gasoline sold statewide might be used to determine emissions from gasoline stations. These emissions would be apportioned

geographically using a surrogate such as population. In the bottom-up approach, surveys of actual facilities were used to determine emission levels. In addition to the data collected from bottom-up surveys, other improvements were made to the 1990 inventory. A brief discussion of the changes made to the inventory follows.

1. Other Product Coatings, High Performance Maintenance and Other Special Purpose Coatings

These categories are all surface coating categories that were estimated for the 1990 inventory using per capita emission factors provided by EPA. The per capita factors were developed from national level estimates of usage of a product divided by the 1989 population. The documentation of the coatings and emissions covered by these categories was not initially available. The TNCRCC, with EPA approval, removed these categories from the 1993 periodic emissions inventory. After further study, documentation of the specific categories and coatings was identified and the 1990 inventory has been adjusted appropriately. Once the categories had been accurately identified, overlap with the point source inventory could be accounted for and an improved area source estimate was obtained.

2. Marine Vessel Loading Losses

Area source emissions in this category were based on estimates of the total amount of VOCs loaded at Texas ports. Texas determined that individual point sources had under reported emissions from this category. When the revised point source emissions are considered, it was determined that the bulk of the emissions in the Beaumont area were covered in the point source emission inventory. Therefore, the area source estimate could be reduced.

3. Surface Cleaning

A contractor performed a bottom-up survey of this category. This survey was later expanded by TNCRCC staff. The results of the survey indicated that the national default estimate of emissions for this category should be revised for the nonattainment areas in Texas.

4. Architectural Coatings

Texas revised emissions estimate by using more recent information from the National Paint and Coatings Association combined with data from surveys on thinner usage.

5. Automobile Refinishing

Texas used more recent information from the National Paint and Coatings

Association and source surveys to revise the emission estimates for this category. In addition, using data from the Department of Commerce on paint shipments, Texas projected a substantial decrease in emissions between 1990 and 1994.

6. Sheet, Strip and Coil

This category was estimated for the 1990 emission factor of 1.5 tons/employee. The number of employees related to this industry was obtained from the County Business Patterns for Standard Industrial Classification (SIC) code 3479. This SIC code includes many businesses not engaged in coil coating operations. A list of companies involved in coil coating operations was obtained from the national coil coaters association. It was determined that all of the companies involved in these operations were outside the nonattainment area or were reporting their emissions in the point source inventory. Therefore, including their emissions in the area source emissions would be double counting. Therefore, the area source emissions were removed from the inventory.

7. Vessels With Outboards

A telephone survey of pleasure craft owners in the Beaumont/Port Arthur

area was conducted. The survey showed that 62 percent of boat usage occurs on weekends rather than on weekdays. Previous emission estimates had allocated pleasure craft emissions equally to each day of the week. It is important to know when emissions occur in developing control strategies. In this case, according to the EPA guidance, emissions are to be reduced from their 1990 summer time weekday levels. Therefore, Texas reduced the expected weekday emissions based on the results of the survey. A similar adjustment had previously been made to the Dallas/Fort Worth and Houston/Galveston inventories.

8. Generators <50 Horsepower

As part of the COAST project, local area-specific construction and recreational area information and more current information about horsepower distributions and equipment/populations were utilized to obtain a more refined estimate of emissions in this category.

9. Residential Lawnmowers

Similar to the survey performed of recreational boat users, a survey of homeowners was performed to determine when they actually cut their lawns. Fifty-nine percent of the

surveyed respondents reported that they cut their lawns on the weekends. Texas reallocated the emissions based on the results of the survey.

10. 1994 Quality Assurance Efforts

During 1994, the TNRC completed a thorough evaluation of the 1990 point source inventory and discovered that emissions from facilities in several SIC codes were misplaced under the wrong emissions category. This effort resulted in significant changes to some emissions categories. The realignment of emissions did not affect the total emissions.

The realignment of emissions did have the effect of increasing the amount of reductions that were expected for certain control measures and decreasing the amount of emission reductions expected from other control measures.

The EPA is proposing to approve these revisions to the 1990 Base Year VOC inventory for the Beaumont/Port Arthur area. The original biogenic emissions are unchanged. A summary of the Revised 1990 emissions inventory for the Beaumont/Port Arthur area is included in Table 1.

TABLE 1.—1990 BASE YEAR EMISSIONS INVENTORY

Beaumont / Port Arthur				
Point	Area	On-Road	Non-Road	Total
245.35	30.63	19.11	18.44	313.53

C. Calculation of the 1996 Target Level of Emissions

Texas subtracted the noncreditable reductions from the FMVCP and RVP program from the 1990 emissions inventory. This subtraction results in the 1990 adjusted inventory. The total required emission reduction required to meet the 15% ROP Plan requirement equals the sum of 15 percent of the adjusted inventory, plus reductions to offset any growth that takes place between 1990 and 1996, plus any reductions that result from corrections to the I/M or VOC RACT rules. Table 2 summarizes the calculations for the Beaumont/Port Arthur area.

TABLE 2: CALCULATION OF REQUIRED REDUCTIONS (TONS/DAY)

Beaumont / Port Arthur	
1990 Emission Inventory	323.77
1990 Adjusted Emission Inventory	313.53

TABLE 2: CALCULATION OF REQUIRED REDUCTIONS (TONS/DAY)—Continued

Beaumont / Port Arthur	
15% of Adjusted	47.03
RACT and I/M Correction	4.28
1996 Target	262.22
1996 Projection ¹	320.01
Required Reduction	57.79

¹ 1996 forecasted emissions with growth and pre-1990 controls.

D. Projections of Growth

As can be seen from the calculations in Table 2, an important component of calculating the required emission reductions is to project the amount of growth in emissions that is expected between 1990 and 1996. Since the 1996 emissions are related to the 1990 emissions, the changes in the 1990 emission inventory resulted in changes to the 1996 projections. In addition, as discussed previously, Texas has projected reductions in the emissions

from surface cleaning and auto refinishing emissions from 1990 levels.

E. Deficiencies Identified in the January 29, 1996 Federal Register

In the January 29, 1996 Federal Register, EPA identified several areas where it was believed that Texas had projected too much emissions reduction for particular control measures. The EPA has reviewed the August 9, 1996, SIP revision and believes that it addresses the previously identified concerns. A brief discussion of the previously identified concerns follows below.

1. Architectural Coatings

Texas projected emission reductions for this category based on past EPA guidance. The guidance, however, was changed in a memorandum dated March 22, 1995 (Credit for the 15 Percent Rate-of-Progress Plans for Reductions from the Architectural and Industrial Maintenance (AIM) Coating Rule). The

August, 1996 SIP revision revises the projected emissions reduction estimate based on the more recent guidance.

Projected emissions reductions from the AIM rule are based on the AIM rule proposed by EPA on June 25, 1995 which expected compliance by April, 1997. Subsequently, EPA was sued over this proposed national rule and has negotiated a compliance date of no earlier than January 1, 1998. The previous guidance allowed States to take emission reduction credit for the AIM rule even though the reductions were not expected to occur until April 1997. The EPA believes that even though the compliance date has been pushed back, the projected emissions reduction from the national AIM rule are creditable in State 15% Plans.

2. Acetone Substitution

Texas had projected emissions reductions for the rules to regulate the cultured (synthetic) marble and fiber reinforced plastic operations. The EPA, however, has added acetone to the list of non-reactive substances. Texas, in the August, 1996 submittal, removed emissions reduction credit for these rules.

3. Vehicle Inspection and Maintenance (I/M)

Under the Federal I/M Flexibility Amendments promulgated September 18, 1995, urbanized areas with a population of less than 200,000 for 1990 are not mandated to participate in the Vehicle I/M program. The State of Texas has elected not to implement a Vehicle I/M program in the Beaumont/Port Arthur nonattainment area.

For a complete discussion of the control measures considered please see the Technical Support Document for this action.

Table 3 summarizes the control measures and their projected emissions reductions used to achieve the 15 percent target.

TABLE 3.—SUMMARY EMISSION REDUCTIONS FOR BEAUMONT/PORT ARTHUR

Required reduction (Tons/Day)	57.79
RACT Catchup	9.88
TSDF	0.01
Vehicle Refueling (Stage II)	1.96
General Vent Gas	11.75
Benzene NESHAPS	0.28
FMVCP Tier I	0.21
Vessel Cleaning	0.02
Fugitives	17.46
RE Floating Roof Tank	25.62
RE Improvements (excluding floating roof tank)	5.04
Gas Utility Engines	0.95
Stage I	1.49

TABLE 3.—SUMMARY EMISSION REDUCTIONS FOR BEAUMONT/PORT ARTHUR—Continued

Architectural Coatings	0.45
Consumer/Commercial Products	0.38
Traffic Markings	0.05
High Performance Maintenance	0.05
Other Special Purpose	0.12
Total Estimated Reductions	75.71

F. Motor Vehicle Emissions Budgets

The Clean Air Act, section 176(c), and the transportation conformity rule require the states to establish MVEBs in any control strategy SIP that is submitted for attainment and maintenance of the NAAQS. The State of Texas has established a MVEB for VOC for the Beaumont/Port Arthur area. The EPA is proposing to approve the following MVEB in Table 4:

TABLE 4.—1996 VOC MOTOR VEHICLE EMISSIONS BUDGET

Area	VOC (tons/day)
Beaumont/Port Arthur	21.66

G. Contingency Measures

Ozone areas classified as moderate or above must include in their submittals, under section 172(c)(9) of the Act, contingency measures to be implemented if Reasonable Further Progress (RFP) is not achieved or if the standard is not attained by the applicable date. The General Preamble to Title I (57 FR 13498) states that the contingency measures should, at a minimum, ensure that an appropriate level of emissions reduction progress continues to be made if attainment or RFP is not achieved and additional planning by the State is needed. Therefore, the EPA interprets the Act to require States with moderate and above ozone nonattainment areas to include sufficient contingency measures in the November 1993 submittal, so that upon implementation of such measures, additional emissions reductions of up to three percent of the adjusted base year inventory (or a lesser percentage that will make up the identified shortfall) would be achieved in the year after the failure has been identified. States must show that their contingency measures can be implemented with minimal further action on their part and with no additional rulemaking actions such as public hearings or legislative review.

III. Analysis of Specific Contingency Measures

The following is a discussion of each of the contingency measures that have been included in the SIP submittals and an analysis of their acceptableness.

A. Gas Utility Engines

Texas has projected emission reductions that will occur from the small engine rule in the year following the required milestone demonstration or 1997. The EPA believes that these reductions have been quantified appropriately.

B. Tier I

Additional reductions are projected for Tier I. The EPA agrees with these reduction estimates.

C. Excess Reductions

Excess reductions from measures in place are sufficient to ensure that the contingency measure target of three percent is met. These emission reductions are in excess of what is required for the area to achieve by November 15, 1996. If Texas has to rely on these measures for contingency measures or for future plans then the State will have one year to backfill the contingency plan.

TABLE 7.—SUMMARY OF CONTINGENCY MEASURES: BEAUMONT/PORT ARTHUR (TONS/DAY)

Required Contingency	9.41
Creditable Contingency Reductions:	
Gas Utility Engines	0.08
Tier I	0.69
Excess from existing measures	17.92
Total	18.69

IV. Final Action

The EPA has evaluated the Emissions Inventory, 15% Plans and contingency measures submitted as part of the August 9, 1996, SIP revision for Texas. The EPA is approving the revisions to the 1990 base year inventory, the 15% Plan, and Contingency Plan for the Beaumont/Port Arthur Area without prior proposal because the Agency views this as a noncontroversial amendment and anticipates no adverse comments. However, in a separate document in this Federal Register publication, EPA is proposing to approve this action should adverse or critical comments be filed. This action will be effective April 13, 1998, unless by March 12, 1998, adverse comments are received.

If EPA receives such comments, this action will be withdrawn before the effective date by publishing a

subsequent document that will withdraw the final action. All public comments received will then be addressed in a subsequent final rule based on proposed action. The EPA will not institute a second comment period. Any parties interested in commenting on this action should do so at this time. If no such comments are received, the public is advised that this action will be effective April 13, 1998.

Nothing in this action should be construed as permitting or allowing or establishing a precedent for any future request for revision to any SIP. Each request for revision to the SIP shall be considered separately in light of specific technical, economic, and environmental factors and in relation to relevant statutory and regulatory requirements.

V. Administrative Requirements

A. Executive Order (E.O.) 12866

The Office of Management and Budget has exempted this regulatory action from E.O. 12866 review.

B. Regulatory Flexibility Act

Under the Regulatory Flexibility Act, 5 U.S.C. 600 *et seq.*, EPA must prepare a regulatory flexibility analysis assessing the impact of any proposed or final rule on small entities. See 5 U.S.C. 603 and 604. Alternatively, EPA may certify that the rule will not have a significant impact on a substantial number of small entities. Small entities include small businesses, small not-for-profit enterprises, and government entities with jurisdiction over populations of less than 50,000.

The SIP approvals under section 110 and subchapter I, part D of the Act do not create any new requirements but simply approve requirements that the State is already imposing. Therefore, because the Federal SIP approval does not impose any new requirements, I certify that it does not have a significant impact on any small entities affected. Moreover, due to the nature of the Federal-State relationship under the Act, preparation of a flexibility analysis would constitute Federal inquiry into the economic reasonableness of State action. The Act forbids EPA to base its actions concerning SIPs on such grounds. See *Union Electric Co. v. U.S. EPA*, 427 U.S. 246, 255-66 (1976); 42 U.S.C. 7410(a)(2).

C. Unfunded Mandates

Under section 202 of the Unfunded Mandates Reform Act of 1995, signed into law on March 22, 1995, EPA must prepare a budgetary impact statement to accompany any proposed or final rule that includes a Federal mandate that

may result in estimated costs to State, local, or tribal governments in the aggregate; or to private sector, of \$100 million or more. Under section 205, EPA must select the most cost-effective and least burdensome alternative that achieves the objectives of the rule and is consistent with statutory requirements. Section 203 requires EPA to establish a plan for informing and advising any small governments that may be significantly or uniquely impacted by the rule.

The EPA has determined that this approval action proposed does not include a Federal mandate that may result in estimated costs of \$100 million or more to either State, local, or tribal governments in the aggregate, or to the private sector. This Federal action approves preexisting requirements under State or local law, and imposes no new Federal requirements. Accordingly, no additional costs to State, local, or tribal governments, or to the private sector, result from this action.

D. Submission to Congress and the General Accounting Office

Under 5 U.S.C. 801(a)(1)(A) as added by the Small Business Regulatory Enforcement Fairness Act of 1996, EPA submitted a report containing this rule and other required information to the U.S. Senate, the U.S. House of Representatives and the Comptroller General of the General Accounting Office prior to publication of this rule in today's *Federal Register*. This rule is not a "major rule" as defined by 5 U.S.C. 804(2).

E. Petitions for Judicial Review

Under section 307(b)(1) of the Act, petitions for judicial review of this action must be filed in the United States Court of Appeals for the appropriate circuit by April 13, 1998. Filing a petition for reconsideration by the Administrator of this final rule does not affect the finality of this rule for the purposes of judicial review nor does it extend the time within which a petition for judicial review may be filed, and shall not postpone the effectiveness of such rule or action. This action may not be challenged later in proceedings to enforce its requirements. See section 307(b)(2) of the Act.

List of Subjects in 40 CFR Part 52

Environmental protection, Air pollution control, Carbon monoxide, Hydrocarbons, Incorporation by reference, Intergovernmental relations, Lead, Nitrogen dioxide, Ozone, Particulate matter, Reporting and

recordkeeping requirements, Sulfur oxides, Volatile organic compounds.

Note: Incorporation by reference of the SIP for the State of Texas was approved by the Director of the *Federal Register* on July 1, 1982.

Dated: January 22, 1998.

Lynda F. Carroll,

Acting Regional Administrator, Region 6.

Part 52, Chapter I, Title 40 of the Code of Federal Regulations is amended as follows:

PART 52—[AMENDED]

1. The authority citation for part 52 continues to read as follows:

Authority: 42 U.S.C. 7401 *et seq.*

Subpart SS—Texas

2. Section 52.2270 is amended by adding paragraph (c)(107) to read as follows:

§ 52.2270 Identification of Plan.

* * * * *

(c) * * *

(107) A revision to the Texas State Implementation Plan addressing the 15% Rate-of-Progress Plan requirements for the Beaumont/Port Arthur ozone nonattainment area was submitted by a cover letter from Governor George Bush dated August 9, 1996. This revision will aid in ensuring that reasonable further progress is made towards attaining the National Ambient Air Quality Standard (NAAQS) for ozone in the Beaumont/Port Arthur area. This submittal also contained revisions to the 1990 base year emissions inventory, Motor Vehicle Emission Budget, and contingency plan for the Beaumont/Port Arthur area.

(i) Incorporation by reference. Texas Natural Resource Conservation Commission (TNRCC) order adopting amendments to the State Implementation Plan; Docket Number 96-0465-SIP, issued July 31, 1996.

(ii) Additional material.

(A) TNRCC certification letter dated July 24, 1996, and signed by Gloria Vasquez, Chief Clerk, TNRCC.

(B) The SIP narrative plan and tables entitled, "Revisions to the State Implementation Plan for the Control of Ozone Air Pollution," as it applies to the Beaumont/Port Arthur area dated July 24, 1996.

3. Section 52.2309 is amended by adding paragraph (d) to read as follows:

§ 52.2309 Emissions inventories.

* * * * *

(d) The Texas Natural Resource Conservation Commission submitted State Implementation Plan revisions to the 1990 base year emission inventory

for the Beaumont/Port Arthur area with a cover letter from the Governor of Texas dated August 9, 1996.

[FR Doc. 98-3319 Filed 2-9-98; 8:45 am]

BILLING CODE 6560-50-P

ENVIRONMENTAL PROTECTION AGENCY

40 CFR Parts 52 and 81

[FRL-5958-9]

Technical Amendments to Clean Air Act Promulgation of Extension of Attainment Date for Ozone Nonattainment Area; Ohio; Kentucky; Correction of Effective Date Under Congressional Review Act (CRA)

AGENCY: Environmental Protection Agency (EPA).

ACTION: Final rule; informational notice; correction of effective date under CRA.

SUMMARY: On November 17, 1997, the Environmental Protection Agency published in the *Federal Register* a final rule extending the attainment date for the Cincinnati-Hamilton interstate moderate ozone nonattainment area from November 15, 1996, to November 15, 1997. This extension is based in part on monitored air quality readings for the national ambient air quality standard (NAAQS) for ozone during 1996. EPA also revised the table in the Code of Federal Regulations concerning ozone attainment dates in this area. The final rule established an effective date of December 17, 1997. This document corrects the effective date of the rule to February 10, 1998, to be consistent with sections 801 and 808 of the Congressional Review Act (CRA), enacted as part of the Small Business Regulatory Enforcement Fairness Act, 5 U.S.C. 801 and 808.

EFFECTIVE DATE: This rule is effective on February 10, 1998.

FOR FURTHER INFORMATION CONTACT: Annette Hill, EPA Region IV, at (404) 562-8287, or Dan Werbie, EPA Region V, at (312) 353-5791.

SUPPLEMENTARY INFORMATION:

I. Background

Section 801 of the CRA precludes a rule from taking effect until the agency promulgating the rule submits a rule report, which includes a copy of the rule, to each House of Congress and to the Comptroller General of the General Accounting Office (GAO). EPA recently discovered that it had inadvertently failed to submit the above rule as required; thus, although the rule was promulgated on November 17, 1997 (62

FR 61241) by operation of law, the rule did not take effect on December 17, 1997, as stated therein. Now that EPA has discovered its error, the rule is being submitted to both Houses of Congress and the GAO. This document amends the effective date of the rule consistent with the provisions of the CRA.

Section 553 of the Administrative Procedure Act, 5 U.S.C. 553(b)(B), provides that, when an agency for good cause finds that notice and public procedure are impracticable, unnecessary or contrary to the public interest, an agency may issue a rule without providing notice and an opportunity for public comment. EPA has determined that there is good cause for making today's rule final without prior proposal and opportunity for comment because EPA merely is correcting the effective date of the promulgated rule to be consistent with the congressional review requirements of the Congressional Review Act as a matter of law and has no discretion in this matter. Thus, notice and public procedure are unnecessary. The Agency finds that this constitutes good cause under 5 U.S.C. 553(b)(B). Moreover, since today's action does not create any new regulatory requirements and affected parties have known of the underlying rule since November 17, 1997, EPA finds that good cause exists to provide for an immediate effective date pursuant to 5 U.S.C. 553(d)(3) and 808(2). Because the delay in the effective date was caused by EPA's inadvertent failure to submit the rule under the CRA, EPA does not believe that affected entities that acted in good faith relying upon the effected date stated in the November 17, 1997, *Federal Register* should be penalized if they were complying with the rule as promulgated.

II. Administrative Requirements

Under Executive Order 12866 (58 FR 51735, October 4, 1993), this action is not a "significant regulatory action" and is therefore not subject to review by the Office of Management and Budget. In addition, this action does not impose any enforceable duty or contain any unfunded mandate as described in the Unfunded Mandates Reform Act of 1995 (Pub. L. 104-4), or require prior consultation with State officials as specified by executive Order 12875 (58 FR 58093, October 28, 1993), or involve special consideration of environmental justice related issues as required by Executive Order 12898 (59 FR 7629, February 16, 1994). Because this action is not subject to notice-and-comment requirements under the Administrative Procedure Act or any other statute, it is

not subject to the regulatory flexibility provisions of the Regulatory Flexibility Act (5 U.S.C. 601 *et seq.*).

Pursuant to 5 U.S.C. 801(a)(1)(A), as added by the Small Business Regulatory Enforcement Fairness Act of 1996, EPA will submit a report containing this rule and other required information to the U.S. Senate, the U.S. House of Representatives and the Comptroller General of the General Accounting Office; however, in accordance with 5 U.S.C. 808(2), this rule is effective on February 10, 1998. This rule is not a "major rule" as defined in 5 U.S.C. 804(2).

This final rule only amends the effective date of the underlying rule; it does not amend any substantive requirements contained in the rule. Accordingly, to the extent it is available, judicial review is limited to the amended effective date. Pursuant to section 307(b)(1) of the Clean Air Act, challenges to this amendment must be brought within 60 days of publication of the amendment.

Dated: January 30, 1998.

Carol Browner,
Administrator.

[FR Doc. 98-3034 Filed 2-9-98; 8:45 am]

BILLING CODE 6560-50-M

ENVIRONMENTAL PROTECTION AGENCY

40 CFR Part 62

[FRL-5961-3]

Technical Amendments To Approval and Promulgation of Implementation of State Air Quality Plans for Designated Facilities and Pollutants, New Mexico; Control of Landfill Gas Emissions From Existing Municipal Solid Waste Landfills; Correction for Same, Louisiana; Correction of Effective Date Under Congressional Review Act (CRA)

AGENCY: Environmental Protection Agency (EPA).

ACTION: Direct final rule; correction of effective date under CRA.

SUMMARY: On October 21, 1997 (62 FR 54589), the Environmental Protection Agency published in the *Federal Register* a direct final rule approving the New Mexico State Plan for controlling landfill gas emissions from existing municipal solid waste landfills. The plan was submitted to fulfill the requirements of the Clean Air Act. The rule established an effective date of December 22, 1997. This document corrects the effective date of the rule to

February 10, 1998, to be consistent with sections 801 and 808 of the Congressional Review Act (CRA), enacted as part of the Small Business Regulatory Enforcement Fairness Act, 5 U.S.C. 801 and 808.

EFFECTIVE DATE: This rule is effective on February 10, 1998.

FOR FURTHER INFORMATION CONTACT: Robyn Meeker, EPA Region X, at (206) 553-8579.

SUPPLEMENTARY INFORMATION:

I. Background

Section 801 of the CRA precludes a rule from taking effect until the agency promulgating the rule submits a rule report, which includes a copy of the rule, to each House of Congress and to the Comptroller General of the General Accounting Office (GAO). EPA recently discovered that it had inadvertently failed to submit the above rule as required; thus, although the rule was promulgated on October 21, 1997 (62 FR 54589) by operation of law, the rule did not take effect on December 22, 1997, as stated therein. Now that EPA has discovered its error, the rule is being submitted to both Houses of Congress and the GAO. This document amends the effective date of the rule consistent with the provisions of the CRA.

Section 553 of the Administrative Procedure Act, 5 U.S.C. 553(b)(B), provides that, when an agency for good cause finds that notice and public procedure are impracticable, unnecessary or contrary to the public interest, an agency may issue a rule without providing notice and an opportunity for public comment. EPA has determined that there is good cause for making today's rule final without prior proposal and opportunity for comment because EPA merely is correcting the effective date of the promulgated rule to be consistent with the congressional review requirements of the Congressional Review Act as a matter of law and has no discretion in this matter. Thus, notice and public procedure are unnecessary. The Agency finds that this constitutes good cause under 5 U.S.C. 553(b)(B). Moreover, since today's action does not create any new regulatory requirements and affected parties have known of the underlying rule since October 21, 1997, EPA finds that good cause exists to provide for an immediate effective date pursuant to 5 U.S.C. 553(d)(3) and 808(2). Because the delay in the effective date was caused by EPA's inadvertent failure to submit the rule under the CRA, EPA does not believe that affected entities that acted in good faith relying upon the effective date

stated in the October 21, 1997, Federal Register should be penalized if they were complying with the rule as promulgated.

II. Administrative Requirements

Under Executive Order 12866 (58 FR 51735, October 4, 1993), this action is not a "significant regulatory action" and is therefore not subject to review by the Office of Management and Budget. In addition, this action does not impose any enforceable duty or contain any unfunded mandate as described in the Unfunded Mandates Reform Act of 1995 (Pub. L. 104-4), or require prior consultation with State officials as specified by Executive Order 12875 (58 FR 58093, October 28, 1993), or involve special consideration of environmental justice related issues as required by Executive Order 12898 (59 FR 7629, February 16, 1994). Because this action is not subject to notice-and-comment requirements under the Administrative Procedure Act or any other statute, it is not subject to the regulatory flexibility provisions of the Regulatory Flexibility Act (5 U.S.C. 601 *et seq.*)

Pursuant to 5 U.S.C. 801(a)(1)(A), as added by the Small Business Regulatory Enforcement Fairness Act of 1996, EPA will submit a report containing this rule and other required information to the U.S. Senate, the U.S. House of Representatives and the Comptroller General of the General Accounting Office; however, in accordance with 5 U.S.C. 808(2), this rule is effective on February 10, 1998. This rule is not a "major rule" as defined in 5 U.S.C. 804(2).

This final rule only amends the effective date of the underlying rule; it does not amend any substantive requirements contained in the rule. Accordingly, to the extent it is available, judicial review is limited to the amended effective date. Pursuant to section 307(b)(1) of the Clean Air Act, challenges to this amendment must be brought within 60 days of publication of the amendment.

Dated: January 30, 1998.

Carol Browner,

Administrator.

[FR Doc. 98-3037 Filed 2-9-98; 8:45 am]

BILLING CODE 6560-50-M

ENVIRONMENTAL PROTECTION AGENCY

40 CFR Parts 180 and 186

[FRL-5959-3]

Technical Amendments to Thiodicarb; Pesticide Tolerance; Correction of Effective Date Under Congressional Review Act (CRA)

AGENCY: Environmental Protection Agency (EPA).

ACTION: Final rule; correction of effective date under CRA.

SUMMARY: On August 22, 1997 (62 FR 44582), the Environmental Protection Agency published in the Federal Register a final rule establishing a tolerance for combined residues of thiodicarb and its metabolite methomyl in or on broccoli, cabbage, cauliflower, and leafy vegetables (except Brassica vegetables), which established an effective date of August 22, 1997. This document corrects the effective date of the rule to February 10, 1998, to be consistent with section 801 and 808 of the Congressional Review Act (CRA), enacted as part of the Small Business Regulatory Enforcement Fairness Act, 5 U.S.C. 801 and 808.

EFFECTIVE DATE: This rule is effective on February 10, 1998.

FOR FURTHER INFORMATION CONTACT: Angela Hofmann, OPPTS, at (202) 260-2922.

SUPPLEMENTARY INFORMATION:

I. Background

Section 801 of the CRA precludes a rule from taking effect until the agency promulgating the rule submits a rule report, which includes a copy of the rule, to each House of Congress and to the Comptroller General of the General Accounting Office (GAO). EPA recently discovered that it had inadvertently failed to submit the above rule as required thus, although the rule was promulgated on August 22, 1997 (62 FR 44582) by operation of law, the rule did not take effect on August 22, 1997, as stated therein. Now that EPA has discovered its error, the rule is being submitted to both Houses of Congress and the GAO. This document amends the effective date of the rule consistent with the provisions of the CRA.

Section 408(e)(2) of the Federal Food, Drug, and Cosmetic Act (FFDCA), 21 U.S.C. 346a(e)(2), provides that the Administrator, before issuing a final rule under section 408(e)(1), shall issue a proposed rule and allow 60 days for public comment unless the Administrator for good cause finds that

it would be in the public interest to provide a shorter period. EPA has determined that there is good cause for making today's rule final without prior proposal and opportunity for comment because EPA merely is correcting the effective date of the promulgated rule to be consistent with the congressional review requirements of the Congressional Review Act as a matter of law and has no discretion in this matter. Thus, notice and public procedure are unnecessary. The Agency finds that this constitutes good cause under section 408(e)(2). Moreover, since today's action does not create any new regulatory requirements and affected parties have known of the underlying rule since August 22, 1997, EPA finds that good cause exists to provide for an immediate effective date pursuant to 5 U.S.C. 808(2). Under section 408(g)(1) of FFDCA, today's rule is effective upon publication. Because the delay in the effective date was caused by EPA's inadvertent failure to submit the rule under the CRA, EPA does not believe that affected entities that acted in good faith relying upon the effective date stated in the August 22, 1997, *Federal Register* should be penalized if they were complying with the rule as promulgated.

II. Administrative Requirements

Under Executive Order 12866 (58 FR 51735, October 4, 1993), this action is not a "significant regulatory action" and is therefore not subject to review by the Office of Management and Budget. In addition, this action does not impose any enforceable duty or contain any unfunded mandate as described in the Unfunded Mandates Reform Act of 1995 (Pub. L. 104-4), or require prior consultation with State officials as specified by Executive Order 12875 (58 FR 58093, October 28, 1993), or involve special consideration of environmental justice related issues as required by Executive Order 12898 (59 FR 7629, February 16, 1994). Because this action is not subject to notice-and-comment requirements under the Administrative Procedure Act or any other statute, it is not subject to the regulatory flexibility provisions of the Regulatory Flexibility Act (5 U.S.C. 601 *se seq.*). EPA's compliance with these statutes and Executive Orders for the underlying rule is discussed in August 22, 1997, *Federal Register* document.

Pursuant to 5 U.S.C. 801(a)(1)(A), as added by the Small Business Regulatory Enforcement Fairness Act of 1996, EPA will submit a report containing this rule and other required information to the U.S. Senate, the U.S. House of Representatives and the Comptroller

General of the General Accounting Office; however, in accordance with 5 U.S.C. 808(2), this rule is effective on February 10, 1998. This rule is not a "major rule" as defined in 5 U.S.C. 804(2).

This final rule only amends the effective date of the underlying rule; it does not amend any substantive requirements contained in the rule. Accordingly, to the extent it is available, judicial review is limited to the amended effective date.

Dated: January 30, 1998.

Carol Browner,
Administrator.

[FR Doc. 98-3028 Filed 2-9-98; 8:45 am]

BILLING CODE 6560-50-M

ENVIRONMENTAL PROTECTION AGENCY

40 CFR Part 271

[FRL-5959-2]

Technical Amendments to Alabama: Final Authorization of Revisions to State's Hazardous Waste Management Program; Correction of Effective Date Under Congressional Review Act (CRA)

AGENCY: Environmental Protection Agency (EPA).

ACTION: Immediate final rule; correction of effective date under CRA.

SUMMARY: On November 21, 1997 (62 FR 62262), the Environmental Protection Agency published in the *Federal Register* an immediate final rule approving Alabama's application for final authorization of revisions to its hazardous waste program under the Resource Conservation and Recovery Act (RCRA), which established an effective date of January 20, 1998. This document corrects the effective date of the rule to February 10, 1998, to be consistent with sections 801 and 808 of the Congressional Review Act (CRA), enacted as part of the Small Business Regulatory Enforcement Fairness Act, 5 U.S.C. 801 and 808.

EFFECTIVE DATE: This rule is effective on February 10, 1998.

FOR FURTHER INFORMATION CONTACT: Annette Hill, EPA Region IV, at (404) 562-8287.

SUPPLEMENTARY INFORMATION:

I. Background

Section 801 of the CRA precludes a rule from taking effect until the agency promulgating the rule submits a rule report, which includes a copy of the rule, to each House of Congress and to

the Comptroller General of the General Accounting Office (GAO). EPA recently discovered that it had inadvertently failed to submit the above rule as required; thus, although the rule was promulgated on November 21, 1997 (62 FR 62262) by operation of law, the rule did not take effect on January 20, 1998, as stated therein. Now that EPA has discovered its error, the rule is being submitted to both Houses of Congress and the GAO. This document amends the effective date of the rule consistent with the provisions of the CRA.

Section 553 of the Administrative Procedure Act, 5 U.S.C. 553(b)(B), provides that, when an agency for good cause finds that notice and public procedure are impracticable, unnecessary or contrary to the public interest, an agency may issue a rule without providing notice and an opportunity for public comment. EPA has determined that there is good cause for making today's rule final without prior proposal and opportunity for comment because EPA merely is correcting the effective date of the promulgated rule to be consistent with the congressional review requirements of the Congressional Review Act as a matter of law and has no discretion in this matter. Thus, notice and public procedure are unnecessary. The Agency finds that this constitutes good cause under 5 U.S.C. 553(b)(B). Moreover, since today's action does not create any new regulatory requirements and affected parties have known of the underlying rule since November 21, 1997, EPA finds that good cause exists to provide for an immediate effective date pursuant to 5 U.S.C. 553(d)(3) and 808(2). Because the delay in the effective date was caused by EPA's inadvertent failure to submit the rule under the CRA, EPA does not believe that affected entities that acted in good faith relying upon the effective date stated in the November 21, 1997, *Federal Register* should be penalized if they were complying with the rule as promulgated.

II. Administrative Requirements

Under Executive Order 12866 (58 FR 51735, October 4, 1993), this action is not a "significant regulatory action" and is therefore not subject to review by the Office of Management and Budget. In addition, this action does not impose any enforceable duty or contain any unfunded mandate as described in the Unfunded Mandates Reform Act of 1995 (Pub. L. 104-4), or require prior consultation with State officials as specified by Executive Order 12875 (58 FR 58093, October 28, 1993), or involve special consideration of environmental

justice related issues as required by Executive Order 12898 (59 FR 7629, February 16, 1994). Because this action is not subject to notice-and-comment requirements under the Administrative Procedure Act or any other statute, it is not subject to the regulatory flexibility provisions of the Regulatory Flexibility Act (5 U.S.C. 601 *et seq.*). EPA's compliance with these statutes and Executive Orders for the underlying rule is discussed in the November 21, 1997, Federal Register document.

Pursuant to 5 U.S.C. 801(a)(1)(A), as added by the Small Business Regulatory Enforcement Fairness Act of 1996, EPA will submit a report containing this rule and other required information to the U.S. Senate, the U.S. House of Representatives and the Comptroller General of the General Accounting Office; however, in accordance with 5 U.S.C. 808(2), this rule is effective on February 10, 1998. This rule is not a "major rule" as defined in 5 U.S.C. 804(2).

This final rule only amends the effective date of the underlying rule; it does not amend any substantive requirements contained in the rule. Accordingly, to the extent it is available, judicial review is limited to the amended effective date.

Dated: January 30, 1998.

Carol Browner,
Administrator.

[FR Doc. 98-3029 Filed 2-9-98; 8:45 am]

BILLING CODE 6560-50-M

ENVIRONMENTAL PROTECTION AGENCY

40 CFR part 281

[FRL-5960-2]

Technical Amendments to West Virginia; Final Approval of State Underground Storage Tank Program; Correction of Effective Date Under Congressional Review Act (CRA)

AGENCY: Environmental Protection Agency (EPA).

ACTION: Notice of final determination; correction of effective date under CRA.

SUMMARY: On September 23, 1997 (62 FR 49620), the Environmental Protection Agency published in the Federal Register a notice of final determination approving the State of West Virginia's underground storage tank program under Subtitle I of the Resource Conservation and Recovery Act, which established an effective date of October 23, 1997. This document corrects the effective date of the rule to

February 10, 1998 to be consistent with sections 801 and 808 of the Congressional Review Act (CRA), enacted as part of the Small Business Regulatory Enforcement Fairness Act, 5 U.S.C. 801 and 808.

EFFECTIVE DATE: This rule is effective on February 10, 1998.

FOR FURTHER INFORMATION CONTACT: Jada Goodwin, EPA Region III, at (215) 566-5381.

SUPPLEMENTARY INFORMATION:

I. Background

Section 801 of the CRA precludes a rule from taking effect until the agency promulgating the rule submits a rule report, which includes a copy of the rule, to each House of Congress and to the Comptroller General of the General Accounting Office (GAO). EPA recently discovered that it had inadvertently failed to submit the above rule as required; thus, although the rule was promulgated on the date stated in the September 23, 1997 (62 FR 49620) by operation of law, the rule did not take effect on October 23, 1997, as stated therein. Now that EPA has discovered its error, the rule is being submitted to both Houses of Congress and the GAO. This document amends the effective date of the rule consistent with the provisions of the CRA.

Section 553 of the Administrative Procedure Act, 5 U.S.C. 553(b)(B), provides that, when an agency for good cause finds that notice and public procedure are impracticable, unnecessary or contrary to the public interest, an agency may issue a rule without providing notice and an opportunity for public comment. EPA has determined that there is good cause for making today's rule final without prior proposal and opportunity for comment because EPA merely is correcting the effective date of the promulgated rule to be consistent with the congressional review requirements of the Congressional Review Act as a matter of law and has no discretion in this matter. Thus, notice and public procedure are unnecessary. The Agency finds that this constitutes good cause under 5 U.S.C. 553(b)(B). Moreover, since today's action does not create any new regulatory requirements and affected parties have known of the underlying rule since September 23, 1997. EPA finds that good cause exists to provide for an immediate effective date pursuant to 5 U.S.C. 553(d)(3) and 808(2). Because the delay in the effective date was caused by EPA's inadvertent failure to submit the rule under the CRA, EPA does not believe that affected entities that acted in good

faith relying upon the effective date stated in the September 23, 1997, Federal Register should be penalized if they were complying with the rule as promulgated.

II. Administrative Requirements

Under Executive Order 12866 (58 FR 51735, October 4, 1993), this action is not a "significant regulatory action" and is therefore not subject to review by the Office of Management and Budget. In addition, this action does not impose any enforceable duty or contain any unfunded mandate as described in the Unfunded Mandates Reform Act of 1995 (Pub. L. 104-4), or require not prior consultation with State officials as specified by Executive Order 12875 (58 FR 58093, October 28, 1993), or involve special consideration of environmental justice related issues as required by Executive Order 12898 (59 FR 7629, February 16, 1994). Because this action is not subject to notice-and-comment requirements under the Administrative Procedure Act or any other statute, it is not subject to the regulatory flexibility provisions of the Regulatory Flexibility Act (5 U.S.C. 601 *et seq.*). EPA's compliance with these statutes and Executive Orders for the underlying rule is discussed in September 23, 1997, Federal Register document.

Pursuant to 5 U.S.C. 801(a)(1)(A), as added by the Small Business Regulatory Enforcement Fairness Act of 1996, EPA will submit a report containing this rule and other required information to the U.S. Senate, the U.S. House of Representatives and the Comptroller General of the General Accounting Office; however, in accordance with 5 U.S.C. 808(2), this rule is effective on February 10, 1998. This rule is not a "major rule" as defined in 5 U.S.C. 804(2).

This final rule only amends the effective date of the underlying rule; it does not amend any substantive requirements contained in the rule. Accordingly, to the extent it is available, judicial review is limited to the amended effective date.

Dated: January 30, 1998.

Carol Browner,
Administrator.

[FR Doc. 98-3030 Filed 2-9-98; 8:45 am]

BILLING CODE 6560-50-M

**ENVIRONMENTAL PROTECTION
AGENCY**
40 CFR Part 372

[FRL-6959-7]

**Technical Amendments to
Hydrochloric Acid; Toxic Chemical
Release Reporting; Community Right-
to-Know; Correction of Effective Date
Under Congressional Review Act
(CRA)**
AGENCY: Environmental Protection
Agency (EPA).

ACTION: Final rule; correction effective
date under CRA.*

SUMMARY: On July 25, 1996 (61 FR 38600), the Environmental Protection Agency published in the *Federal Register* a final rule modifying the listing for hydrochloric acid on the list of toxic chemicals subject to the reporting requirements under section 313 of the Emergency Planning and Community Right-to-Know Act of 1986, and section 6607 of the Pollution Prevention Act of 1990, which established an effective date of July 25, 1996. This document corrects the effective date of the rule to February 10, 1998 to be consistent with sections 801 and 808 of the Congressional Review Act (CRA), enacted as part of the Small Business Regulatory Enforcement Fairness Act, 5 U.S.C. 801 and 808.

EFFECTIVE DATE: This rule is effective on February 10, 1998.

FOR FURTHER INFORMATION CONTACT: Angela Hofmann, OPPTS, at (202) 260-2922.

SUPPLEMENTARY INFORMATION:
I. Background

Section 801 of the CRA precludes a rule from taking effect until the agency promulgating the rule submits a rule report, which includes a copy of the rule, to each House of Congress and to the Comptroller General of the General Accounting Office (GAO). EPA recently discovered that it had inadvertently failed to submit the above rule as required; thus, although the rule was promulgated on July 25, 1996 (61 FR 38600) by operation of law, the rule did not take effect on July 25, 1996, as stated therein. Now the EPA has discovered its error, the rule is being submitted to both Houses of Congress and the GAO. This document amends the effective date of the rule consistent with the provisions of the CRA.

Section 553 of the Administrative Procedure Act, 5 U.S.C. 553(b)(B), provides that, when an agency for good cause finds that notice and public

procedure are impracticable, unnecessary or contrary to the public interest, an agency may issue a rule without providing notice and an opportunity for public comment. EPA has determined that there is good cause for making today's rule final without prior proposal and opportunity for comment because EPA merely is correcting the effective date of the promulgated rule to be consistent with the congressional review requirements of the Congressional Review Act as a matter of law and has no discretion in this matter. Thus, notice and public procedure are unnecessary. The Agency finds that this constitutes good cause under 5 U.S.C. 553(b)(B). Moreover, since today's action does not create any new regulatory requirements and affected parties have known of the underlying rule since July 25, 1996, EPA finds that good cause exists to provide for an immediate effective date pursuant to 5 U.S.C. 553(d)(3) and 808(2). Because the delay in the effective date was caused by EPA's inadvertent failure to submit the rule under the CRA, EPA does not believe that affected entities that acted in good faith relying upon the effective date stated in the July 25, 1996, *Federal Register* should be penalized if they were complying with the rule as promulgated.

II. Administrative Requirements

Under Executive Order 12866 (58 FR 51735, October 4, 1993), this action is not a "significant regulatory action" and is therefore not subject to review by the Office of Management and Budget. In addition, this action does not impose any enforceable duty or contain any unfunded mandate as described in the Unfunded Mandates Reform Act of 1995 (Pub. L. 104-4), or require prior consultation with State officials as specified by Executive Order 12875 (58 FR 58093, October 28, 1993), or involve special consideration of environmental justice related issues as required by Executive Order 12898 (59 FR 7629, February 16, 1994). Because this action is not subject to notice-and-comment requirements under the Administrative Procedure Act or any other statute, it is not subject to the regulatory flexibility provisions of the Regulatory Flexibility Act (5 U.S.C. 601 *et seq.*). EPA's compliance with these statutes and Executive Orders for the underlying rule is discussed in the July 25, 1996, *Federal Register* document.

Pursuant to 5 U.S.C. 801(a)(1)(A), as added by the Small Business Regulatory Enforcement Fairness Act of 1996, EPA will submit a report containing this rule and other required information to the U.S. Senate, the U.S. House of

Representatives and the Comptroller General of the General Accounting Office; however, in accordance with 5 U.S.C. 808(2), this rule is effective on February 10, 1998. This rule is not a "major rule" as defined in 5 U.S.C. 804(2).

This final rule only amends the effective date of the underlying rule; it does not amend any substantive requirements contained in the rule. Accordingly, to the extent it is available, judicial review is limited to the amended effective date.

Dated: January 30, 1998.

Carol Browner,
Administrator.

[FR Doc. 98-3032 Filed 2-9-98; 8:45 am]

BILLING CODE 6560-50-M

**ENVIRONMENTAL PROTECTION
AGENCY**
40 CFR Part 721

[FRL-6959-5]

**Technical Amendments to
Cyclohexanecarbonitrile, 1,3,3-
trimethyl-5-oxo; Revocation of a
Significant New Use Rule; Correction
of Effective Date Under Congressional
Review Act (CRA)**
AGENCY: Environmental Protection
Agency (EPA).

ACTION: Final rule; correction of
effective date under CRA.

SUMMARY: On June 27, 1996 (61 FR 33373), the Environmental Protection Agency published in the *Federal Register* a final rule revoking a significant new use rule promulgated under section 5(a)(2) of the Toxic Substances Control Act for cyclohexanecarbonitrile, 1,3,3-trimethyl-5-oxo- based on receipt of new data, which established an effective date of July 29, 1996. This document corrects the effective date of the rule to February 10, 1998, to be consistent with sections 801 and 808 of the Congressional Review Act (CRA), enacted as part of the Small Business Regulatory Enforcement Fairness Act, 5 U.S.C. 801 and 808.

EFFECTIVE DATE: This rule is effective on February 10, 1998.

FOR FURTHER INFORMATION CONTACT: Angela Hofmann, OPPTS, at (202) 260-2922.

SUPPLEMENTARY INFORMATION:
I. Background

Section 801 of the CRA precludes a rule from taking effect until the agency promulgating the rule submits a rule report, which includes a copy of the

rule, to each House of Congress and to the Comptroller General of the General Accounting Office (GAO). EPA recently discovered that it had inadvertently failed to submit the above rule as required; thus, although the rule was promulgated on June 27, 1996 (61 FR 33373) by operation of law, the rule did not take effect on July 29, 1996, as stated therein. Now that EPA has discovered its error, the rule is being submitted to both Houses of Congress and the GAO. This document amends the effective date of the rule consistent with the provisions of the CRA.

Section 553 of the Administrative Procedure Act, 5 U.S.C. 553(b)(B), provides that, when an agency for good cause finds that notice and public procedure are impracticable, unnecessary or contrary to the public interest, an agency may issue a rule without providing notice and an opportunity for public comment. EPA has determined that there is good cause for making today's rule final without prior proposal and opportunity for comment because EPA merely is correcting the effective date of the promulgated rule to be consistent with the congressional review requirements of the Congressional Review Act as a matter of law and has no discretion in this matter. Thus, notice and public procedure are unnecessary. The Agency finds that this constitutes good cause under 5 U.S.C. 553(b)(B). Moreover, since today's action does not create any new regulatory requirements and affected parties have known of the underlying rule since June 27, 1996, EPA finds that good cause exists to provide for an immediate effective date pursuant to 5 U.S.C. 553(d)(3) and 808(2). Because the delay in the effective date was caused by EPA's inadvertent failure to submit the rule under the CRA, EPA does not believe that affected entities that acted in good faith relying upon the effective date stated in the June 27, 1996, *Federal Register* should be penalized if they were complying with the rule as promulgated.

II. Administrative Requirements

Under Executive Order 12866 (58 FR 51735, October 4, 1993), this action is not a "significant regulatory action" and is therefore not subject to review by the Office of Management and Budget. In addition, this action does not impose any enforceable duty or contain any unfunded mandate as described in the Unfunded Mandates Reform Act of 1995 (Pub. L. 104-4), or require prior consultation with State officials as specified by Executive Order 12875 (58093, October 28, 1993), or involve

special consideration of environmental justice related issues as required by Executive Order 12898 (59 FR 7629, February 16, 1994). Because this action is not subject to notice-and-comment requirements under the Administrative Procedure Act or any other statute, it is not subject to the regulatory flexibility provisions of the Regulatory Flexibility Act (5 U.S.C. 601 *et seq.*). EPA's compliance with these statutes and Executive Orders for the underlying rule is discussed in June 27, 1996, *Federal Register* document.

Pursuant to 5 U.S.C. 801(a)(1)(A), as added by the Small Business Regulatory Enforcement Fairness Act of 1996, EPA will submit a report containing this rule and other required information to the U.S. Senate, the U.S. House of Representatives and the Comptroller General of the General Accounting Office; however, in accordance with 5 U.S.C. 808(2), this rule is effective on February 10, 1998. This rule is not a "major rule" as defined in 5 U.S.C. 804(2).

This final rule only amends the effective date of the underlying rule; it does not amend any substantive requirements contained in the rule. Accordingly, to the extent it is available, judicial review is limited to the amended effective date.

Dated: January 30, 1998.

Carol Browner,
Administrator.

[FR Doc. 98-3026 Filed 2-9-98; 8:45 am]

BILLING CODE 6560-50-M

FEDERAL COMMUNICATIONS COMMISSION

47 CFR Part 2

[ET Docket No. 97-157; FCC 97-421]

Reallocation of TV Channels 60-69, the 746-806 MHz Band

AGENCY: Federal Communications Commission.

ACTION: Final rule.

SUMMARY: By this *Report and Order* ("R&O"), the Commission reallocates the 746-806 MHz band, currently television (TV) channels 60-69, as proposed in the *Notice of Proposed Rule Making* ("Notice") in this proceeding. In consultation with the Secretary of Commerce and the Attorney General, we allocate 24 megahertz of this band, at 764-776 MHz and 794-806 MHz, on a primary basis to the fixed and mobile services, and designate this spectrum for public safety use. We allocate the remaining 36 megahertz of the band on

a primary basis to the fixed, mobile, and new broadcasting services for commercial use, to be assigned by auction. During the digital television ("DTV") transition period, TV channels 60-69 will continue to be used for analog and digital TV broadcasting. We are establishing policies for the protection of such stations during the DTV transition. We are also providing for continued use of TV channels 60-69 on a secondary basis for low power TV and translator stations until the end of the DTV transition period.

EFFECTIVE DATE: April 13, 1998.

FOR FURTHER INFORMATION CONTACT: Sean White, Office of Engineering and Technology, (202) 418-2453.

SUPPLEMENTARY INFORMATION: This is a summary of the Commission's *Report and Order*, ET Docket 97-157, FCC 97-421, adopted December 31, 1997, and released January 6, 1998. The full text of this Commission decision is available for inspection and copying during normal business hours in the FCC Reference Center (Room 239), 1919 M Street, N.W., Washington, D.C., and also may be purchased from the Commission's duplication contractor, International Transcription Service, (202) 857-3800, 1231 20th Street, N.W., Washington, D.C. 20036.

Summary of the Report and Order

1. This *Report and Order* reallocates the 746-806 MHz band, currently comprising television (TV) channels 60-69, as proposed in the Notice of Proposed Rule Making in this proceeding, 62 FR 41012, July 31, 1997. The Balanced Budget Act of 1997 (Budget Act) requires the allocation of 24 megahertz of spectrum for public safety from TV channels 60-69, in consultation with the Secretary of Commerce and the Attorney General, not later than January 1, 1998.¹ There is inadequate spectrum to meet the needs of many public safety organizations, particularly in major metropolitan regions. Public safety requires spectrum to facilitate interoperability and for new types of communications capabilities that will strengthen and enhance public safety. Therefore, as required by the Budget Act, after consulting with and considering the views of the Secretary of Commerce and the Attorney General, we are allocating 24 MHz of spectrum (TV Channels 63, 64, 68, and 69, or, in other words, the 764-776 MHz and 794-806 MHz bands) to the fixed and mobile services on a primary basis for public

¹ See Budget Act, section 3004 (adding new section 337 of the Communications Act).

safety services.² We have initiated a separate proceeding to establish the rules that will govern how this spectrum will be used by public safety agencies. Also in accordance with the Budget Act, we are allocating the remaining 36 megahertz of channels 60–69 to the fixed and mobile services on a primary basis, and retaining the primary allocation of this spectrum to the broadcasting service. Licenses in this 36 megahertz of spectrum will be assigned to commercial licensees through competitive bidding in accordance with procedures that will be determined in a later proceeding. This 36 megahertz of commercial spectrum can be used to make new technologies and services available to the American public. These proposals are an outgrowth of our digital television (DTV) transition plan. During the DTV transition, channels 60–69 will continue to be used for analog and digital TV broadcasting. We are establishing policies for the protection of such stations during the DTV transition. We are also providing for continued use of TV channels 60–69 on a secondary basis for low power TV and translator stations until the end of the DTV transition period.

2. We do not adopt an alternative proposal to allocate channels 66–69 for public safety instead of channels 63, 64, 68, and 69. It is not clear that this alternative proposal would reduce adjacent channel interference. In any event, properly crafted technical rules will minimize adjacent channel interference. More importantly, this proposal would have a severe impact on public safety radio communications equipment. We anticipate that much of the public safety communications in the 746–806 MHz band will be two-way. Two-way radios require filtering to permit simultaneous transmission and reception. Small separations between transmit and receive frequencies increase the size, weight, power requirements, and cost of these radios. The mobile nature of public safety

communications requires that these factors be minimized to the extent possible. Manufacturers of radio equipment have expressed confidence in their ability to design two-way public safety radios with transmit/receive separations of 30 megahertz. On the other hand, shorter separations, such as the 12 megahertz suggested by the alternate proposal, would significantly increase the cost and weight of public safety radio equipment. Further, the 30 megahertz separation proposed in the Notice will allow the design of public safety equipment more compatible with, and more easily integrated into, current public safety systems in the 800 MHz band. On balance, we believe that channels 63, 64, 68, and 69 are most appropriate for public safety use, and therefore, we are reallocating the 764–776 MHz and 794–806 MHz bands to the fixed and mobile services for this purpose.

3. We reject the argument that broadcasting should not retain an allocation in the 36 megahertz of commercial spectrum after the DTV transition. Commenters generally agreed that including full power broadcasting in this spectrum is likely to cause interference problems with other commercial applications, especially low-power mobile applications. We recognize that technical challenges are involved in sharing spectrum between full power broadcasting and land mobile services. However, we plan to address sharing issues in our service rules proceeding, and are not persuaded that such sharing is not feasible. At the same time, we wish to make it clear that analog TV and DTV operations not licensed by competitive bidding as provided by the Budget Act will be required to vacate this spectrum in accordance with the DTV transition plan. Finally, we find that this allocation will not deter investment in new communications services or systems, because the 746–806 MHz band is highly desirable spectrum for fixed, mobile, and broadcasting operations, any of which are likely to attract investment interest.

4. We observe that our DTV transition plan is currently under review in a separate proceeding, and that additional DTV allotments are under consideration for channels 60–69. However, we reject the argument that we should avoid reallocating this spectrum in order to provide a “safe haven” for addressing problems that may arise during the DTV transition. As an initial matter, we note that the Budget Act directs the Commission to allocate 24 megahertz of this spectrum for public safety use and 36 megahertz for commercial use by

January 1, 1998. Thus we do not have the latitude to delay reallocation of this spectrum. Moreover, even if we had the discretion to do so, we do not believe it would be necessary to retain this spectrum as a “safe haven”. The DTV transition plan is the product of extensive technical study and review. If problems should arise, in most cases alternative solutions to use of channels 60–69 will be available. The limited potential benefits of retaining channels 60–69 as a “safe haven” are outweighed by the costs of delaying much needed public safety services and opportunities for new services. We also find no merit in the argument that we should remove immediately all TV broadcasting operations from TV channels 60–69. The operation of some TV and DTV stations in this spectrum is clearly required to facilitate the DTV transition; and the Budget Act provides for this, stating “[a]ny person who holds a television broadcast license to operate between 746 and 806 megahertz may not operate at that frequency after the date on which the digital television service transition period terminates, as determined by the Commission.”

5. We recognize that the DTV transition and the reallocation of TV channels 60–69 to other services will have a significant impact on LPTV and TV translators. While we are committed to take reasonable steps to reduce the impact on such operations, we are obligated to facilitate the DTV transition and to reallocate the TV channels 60–69 as directed under the Budget Act. Section 3004 of the Budget Act states that anyone holding a television broadcast license in the band “may not operate at that frequency after the date on which the digital television transition period terminates, as determined by the Commission.”³ This provision of the Budget Act leaves us no latitude in clearing LPTV and TV translator stations from the band at the end of the DTV transition period. We will permit LPTV and TV translators to continue to operate on channels 60–69 until the end of the DTV transition period, as long as they do not cause harmful interference to primary services. The DTV transition period is currently scheduled to end December 31, 2006, but may be extended in some markets for several reasons.⁴ In many rural areas, LPTV and TV translator licensees will be able to continue

³ See Budget Act section 3004 (adding new section 337(e)(1) of the Communications Act).

⁴ Budget Act section 3003 (adding new section 309(j)(14) of the Communications Act) establishes the conditions under which the Commission shall extend the end of the DTV transition period beyond December 31, 2006.

² The Budget Act provides that this spectrum is to be allocated “for public safety services according to the terms and conditions established by the Commission, in consultation with the Secretary of Commerce and the Attorney General.” Budget Act section 3004(a)(1). Section 3004 of the Budget Act defines public safety services as

Services—

- (A) The sole or principal purpose of which is to protect the safety of life, health, or property;
- (B) That are provided—
 - (i) By State or local government entities; or
 - (ii) By nongovernmental organizations that are authorized by a governmental entity whose primary mission is the provision of such services; and
- (C) That are not made commercially available to the public by the provider.

Budget Act section 3004(f)(1).

broadcasting because demand for spectrum for both public safety and commercial applications is likely to be less in rural areas than in urban areas.

6. LPTV operators also can be accommodated in other ways. We will consider whether there are any other steps that may be of benefit to LPTV and TV translator operations as we develop service rules for the commercial spectrum. We emphasize that all the provisions we made in the *DTV Proceeding Sixth Report and Order* to accommodate LPTV and TV translator stations also apply to LPTV and TV translator stations in channels 60-69.

7. We believe that most holders of TV station construction permits in channels 60-69 are sufficiently advanced in the licensing process that it would be inequitable to rescind their permits. At the same time, as we pointed out in the *Notice*, there are outstanding construction permits that were issued years ago, on which there has been little progress. In order to ensure that holders of construction permits, both for new facilities and modification of existing facilities, progress in construction, we are establishing a deadline by which construction must be completed. We believe that three years is sufficient time for current construction permits to build or improve their facilities, and also provides a date certain for planning purposes for public safety agencies and commercial entities. Therefore, we will cancel any construction permit issued before the release date of this Report and Order for which no license application has been filed as of January 2, 2001.

8. We decline to indefinitely protect analog TV stations up to their maximum possible coverage. Such a measure would deny areas of the country to public safety and commercial licensees, even though the current licensees may never increase their coverage to the maximum. Accordingly, we will protect analog TV licensees up to their actual coverage until the end of the DTV transition period. In this regard, we will process requests for minor modifications to existing analog TV stations and construction permits. However, the planning and development of new services would be impeded if we were to permit modifications that increase service area on an indefinite basis. We believe that licensees have been aware of the DTV transition plan and have had the opportunity to plan necessary modifications. Accordingly, as of six months after the release date of this Report and Order we will no longer accept requests for modifications to increase the service areas of stations

operating on TV channels 60-69. With regard to DTV, we will protect the full coverage area until the end of the DTV transition period.⁵ We recognize that stations may not be able to provide full coverage initially and we do not wish to impede growth and development of DTV.

9. In the *DTV Sixth Further Notice of Proposed Rule Making*, we provided a final opportunity for the filing of new applications for analog stations for vacant allotments and rule making petitions to add channels to the TV Table of Allotments, thereby accommodating parties who were in the process of preparing application and rule making submissions. We are aware of the investment in planning, effort, and money that have been put into these and other pending applications and petitions to amend the TV allotment table. However, we continue to believe that it is important to maximize the utility of the 746-806 MHz band for public safety and new commercial services. For these reasons, we will not authorize additional new analog full-service television stations on channels 60-69. However, we will at a later date provide applicants and petitioners an opportunity to amend their applications and petitions, if possible, to seek a channel below channel 60. We will thereafter dismiss any applications or allotment petitions that are not satisfactorily amended. We direct the Mass Media Bureau to announce the details of this amendment opportunity by Public Notice, at a date after we complete action on our broadcast auction proceeding and the petitions for reconsideration in the DTV proceeding. To encourage settlements among mutually exclusive applicants, we authorize the Mass Media Bureau to waive for this special amendment opportunity the rule which limits reimbursements of applicants to legitimate and prudent expenses (47 CFR 73.3525(a)(3)). Finally, we note that all conditions pertaining to the applications and rule making petitions will continue to apply.

Final Regulatory Flexibility Analysis

10. As required by the Regulatory Flexibility Act (RFA),⁶ the Commission incorporated an Initial Regulatory Flexibility Analysis (IRFA) of the expected significant economic impact on small entities in the *Notice of Proposed Rule Making* (Notice) in this proceeding. The Commission sought written public comments on the

proposals in the *Notice*, including the IRFA. This Final Regulatory Flexibility Analysis (FRFA) conforms to the RFA, as amended by the Contract With America Advancement Act of 1996 (CWAAA), Public Law 104-121, 110 Stat. 847.7

A. Need for and Purpose of This Action

11. In this Report and Order, the Commission reallocates the 746-806 MHz band, television (TV) Channels 60-69, to other services. We allocate 24 megahertz at 764-776 MHz and 794-806 MHz for public safety use. We allocate the remaining 36 megahertz at 746-764 MHz and 776-794 MHz to the fixed and mobile services, and to retain the allocation to the broadcasting service in these bands. We further assure the protection of full-power TV stations in the band until the transition to digital television (DTV) is complete, and retain the secondary status in the band of Low Power TV (LPTV) and TV translator stations until the end of the DTV transition period. These allocations will help alleviate a critical shortage of public safety spectrum, make new technologies and services available to the American public, and allow more efficient use of spectrum in the 746-806 MHz band.

B. Legal Basis

12. This action is taken pursuant to Sections 4(i), 303(c), 303(f), 303(g), 303(r), and 337(a) of the Communications Act of 1934, as amended, 47 U.S.C. 154(i), 303(c), 303(f), 303(g), 303(r), and 337(a); and section 3004 of the Balanced Budget Act of 1997, Public Law 105-33, 111 Stat. 251 section 3004 (1997).

C. Summary of Issues Raised by the Public Comments in Response to the IRFA

13. One commenter responded to the IRFA. The Mountain Broadcasting Corporation (Mountain) states that individual small businesses in the television broadcasting industry will be harmed by interference and loss of service resulting from our attempts to clear channels 60-69, while providing interference protection for DTV service during the DTV transition. Mountain contends that existing analog UHF stations must be protected from interference from new DTV stations.⁸

⁷ Public Law 104-121, 110 Stat. 847 (1996)(CWAAA, Subtitle II of the Small Business Regulatory Enforcement Fairness Act of 1996 (SBREFA), codified at 5 U.S.C. 601 et seq.).

⁸ See Mountain Comments at 5-6.

⁵ DTV coverage areas are established in the *DTV Sixth Report and Order*, ¶¶ 29-33.

⁶ 5 U.S.C. 603.

D. Changes Made to the Proposed Rules

14. In the *Notice* in this proceeding, released July 10, 1997, we proposed to reallocate the 746–806 MHz band, currently comprising TV channels 60–69. We proposed to allocate 24 megahertz, at 764–776 MHz and 794–806 MHz (channels 63, 64, 68, and 69) to the fixed and mobile services, for the exclusive use of public safety services. We proposed to allocate the remaining 36 megahertz, at 746–764 MHz and 776–794 MHz (channels 60–62 and 65–67) to the fixed, mobile, and broadcasting services. We stated in the *Notice* that we anticipated that licenses in this 36 megahertz of spectrum would be assigned through competitive bidding. We also inquired into protection of TV stations on channels 60–69 from interference by new licensees during the DTV transition period, but deferred specific interference protection standards to a separate proceeding on service rules for the 746–806 MHz band. We reaffirmed the secondary status of LPTV and TV translators in the entire 746–806 MHz band until the end of the DTV transition period, and inquired whether we should take any other measures to accommodate LPTV in the band.

15. This Report and Order contains no substantial changes to the *Notice*. The only commenter who addressed the IRFA in the *Notice* addressed potential DTV-to-analog TV interference problems. This was not an issue in this proceeding; it was therefore impossible to address the comment in this Report and Order.

E. Description and Estimate of the Number of Small Entities to Which the Proposed Rules Will Apply

16. *Definition of a "small business"*. Under the RFA, small entities may include small organizations, small businesses, and small governmental jurisdictions. 5 U.S.C. 601(6). The RFA, 5 U.S.C. 601(3), generally defines the term "small business" as having the same meaning as the term "small business concern" under the Small Business Act, 15 U.S.C. 632. A small business concern is one which: (1) is independently owned and operated; (2) is not dominant in its field of operation; and (3) satisfies any additional criteria established by the Small Business Administration ("SBA"). According to the SBA's regulations, entities engaged in television broadcasting Standard Industrial Classification ("SIC") Code 4833—Television Broadcasting Stations, may have a maximum of \$10.5 million in annual receipts in order to qualify as a small business concern. This standard

also applies in determining whether an entity is a small business for purposes of the RFA.

17. *Issues in applying the definition of a "small business"*. As discussed below, we could not precisely apply the foregoing definition of "small business" in developing our estimates of the number of small entities to which the rules will apply. Our estimates reflect our best judgments based on the data available to us.

An element of the definition of "small business" is that the entity not be dominant in its field of operation. We were unable at this time to define or quantify the criteria that would establish whether a specific television station is dominant in its field of operation. Accordingly, the following estimates of small businesses to which the new rules will apply do not exclude any television station from the definition of a small business on this basis and are therefore over inclusive to that extent. An additional element of the definition of "small business" is that the entity must be independently owned and operated. As discussed further below, we could not fully apply this criterion, and our estimates of small businesses to which the rules may apply may be over inclusive to this extent. The SBA's general size standards are developed taking into account these two statutory criteria. This does not preclude us from taking these factors into account in making our estimates of the numbers of small entities.

18. *Television station estimates based on census data*. The *Notice of Proposed Rule Making* will affect full service television stations, TV translator facilities, and LPTV stations. The Small Business Administration defines a television broadcasting station that has no more than \$10.5 million in annual receipts as a small business.⁹ Television broadcasting stations consist of establishments primarily engaged in broadcasting visual programs by television to the public, except cable and other pay television services.¹⁰ Included in this industry are commercial, religious, educational, and other television stations.¹¹ Also

⁹ 13 CFR 121.201, Standard Industrial Code (SIC) 4833 (1996).

¹⁰ Economics and Statistics Administration, Bureau of Census, U.S. Department of Commerce, 1992 Census of Transportation, Communications and Utilities, Establishment and Firm Size, Series UC92-S-1, Appendix A-9 (1995).

¹¹ *Id.* See Executive Office of the President, Office of Management and Budget, Standard Industrial Classification Manual (1987), at 283, which describes "Television Broadcasting Stations (SIC Code 4833) as:

Establishments primarily engaged in broadcasting visual programs by television to the public, except

included are establishments primarily engaged in television broadcasting and which produce taped television program materials.¹² Separate establishments primarily engaged in producing taped television program materials are classified under another SIC number.¹³

19. There were 1,509 television stations operating in the nation in 1992.¹⁴ That number has remained fairly constant as indicated by the approximately 1,551 operating television broadcasting stations in the nation as of February 28, 1997.¹⁵ For 1992¹⁶ the number of television stations that produced less than \$10.0 million in revenue was 1,155 establishments, or approximately 77 percent of the 1,509 establishments.¹⁷ Thus, the rules will affect approximately 1,551 television stations; approximately 1,194 of those stations are considered small businesses.¹⁸ These estimates may overstate the number of small entities since the revenue figures on which they are based do not include or aggregate revenues from non-television affiliated companies. We recognize that the rules may also impact minority and women owned stations, some of which may be small entities. In 1995, minorities owned and controlled 37 (3.0%) of 1,221 commercial television stations in the United States.¹⁹ According to the

cable and other pay television services. Included in this industry are commercial, religious, educational and other television stations. Also included here are establishments primarily engaged in television broadcasting and which produce taped television program materials.

¹² Economics and Statistics Administration, Bureau of Census, U.S. Department of Commerce, *supra* note 7, Appendix A-9.

¹³ *Id.*; SIC 7812 (Motion Picture and Video Tape Production); SIC 7922 (Theatrical Producers and Miscellaneous Theatrical Services (producers of live radio and television programs).

¹⁴ FCC News Release No. 31327, Jan. 13, 1993; Economics and Statistics Administration, Bureau of Census, U.S. Department of Commerce, *supra* note 7, Appendix A-9.

¹⁵ FCC News Release No. 7033, March 6, 1997.

¹⁶ Census for Communications' establishments are performed every five years ending with a "2" or "7". See Economics and Statistics Administration, Bureau of Census, U.S. Department of Commerce, *supra* note 7, at III.

¹⁷ The amount of \$10 million was used to estimate the number of small business establishments because the relevant Census categories stopped at \$9,999,999 and began at \$10,000,000. No category for \$10.5 million existed. Thus, the number is as accurate as it is possible to calculate with the available information.

¹⁸ We use the 77 percent figure of TV stations operating at less than \$10 million for 1992 and apply it to the 1997 total of 1551 TV stations to arrive at 1,194 stations categorized as small businesses.

¹⁹ *Minority Commercial Broadcast Ownership in the United States*, U.S. Dep't of Commerce, National Telecommunications and Information Administration, The Minority Telecommunications

U.S. Bureau of the Census, in 1987 women owned and controlled 27 (1.9%) of 1,342 commercial and non-commercial television stations in the United States.²⁰

20. There are currently 4,977 TV translator stations and 1,952 LPTV stations which would be affected by the allocation policy and other policies in this proceeding.²¹ The Commission does not collect financial information of any broadcast facility and the Department of Commerce does not collect financial information on these broadcast facilities. We will assume for present purposes, however, that most of these broadcast facilities, including LPTV stations, could be classified as small businesses. As indicated earlier, approximately 77 percent of television stations are designated under this analysis as potentially small business. Given this, LPTV and TV translator stations would not likely have revenues that exceed the SBA maximum to be designated as small businesses.

21. *Alternative classification of small television stations.* An alternative way to classify small television stations is by the number of employees. The Commission currently applies a standard based on the number of employees in administering its Equal Employment Opportunity ("EEO") rule for broadcasting.²² Thus, radio or

television stations with fewer than five full-time employees are exempted from certain EEO reporting and record keeping requirements.²³ We estimate that the total number of commercial television stations with 4 or fewer employees is 132 and that the total number of noncommercial educational television stations with 4 or fewer employees is 136.²⁴

22. We have concluded that the 746-806 MHz band can be recovered immediately, and that it is in the public interest to reallocate this spectrum to uses in addition to TV broadcasting. We believe that such a reallocation is possible while continuing to protect TV. There are 95 full power TV stations, either operating or with approved construction permits, in Channel 60-69. There are also nine proposed stations, and approximately 15 stations will be added during the DTV transition period, for a total of approximately 110 nationwide. There are also approximately 1,366 LPTV stations and TV translator stations in the band, operating on a secondary basis to full power TV stations. We propose to immediately reallocate the 746-806 MHz band in order to maximize the public benefit available from its use.

23. The RFA also includes small governmental entities as a part of the regulatory flexibility analysis.²⁵ The definition of a small governmental entity is one with a population of fewer than 50,000.²⁶ There are approximately 85,006 governmental entities in the

nation.²⁷ This number includes such entities as states, counties, cities, utility districts and school districts. There are no figures available on what portion of this number have populations of fewer than 50,000. However, this number includes 38,978 counties, cities and towns, and of those, 37,566, or 96 percent, have populations of fewer than 50,000.²⁸ The Census Bureau estimates that this ratio is approximately accurate for all governmental entities. Thus, of the approximately 85,006 governmental entities, we estimate that 96 percent, or 81,600, are small entities that may be affected by our rules.

F. Description of Projected Reporting, Record Keeping and Other Compliance Requirements

24. None.

G. Significant Alternatives Considered and Rejected

25. We do not provide LPTV and TV translator stations with the same protection afforded to full-power TV stations. Because of the large number of such stations, protecting them would significantly diminish the utility of the 746-806 MHz band to both public safety and commercial users. Also, LPTV and TV translator stations are secondary in this band, and we have made public safety and commercial services primary in the band. We affirm measures which will allow as many LPTV and TV translator stations as possible to remain in operation until the end of the DTV transition period. We continue the secondary status of these stations, so that they will not be required to change or cease their operations until they actually interfere with one of the newly allocated services.

H. Federal Rules That May Duplicate, Overlap, or Conflict With the Proposed Rules

26. None.

List of Subjects in 47 CFR Part 2

Frequency allocations and radio treaty matters, Radio.

Federal Communications Commission.

William F. Caton,
Deputy Secretary.

Rules Changes

For the reasons discussed in the preamble part 2 of title 47 of the Code of Federal Regulations, is amended as follows:

²⁷ 1992 Census of Governments, U.S. Bureau of the Census, U.S. Department of Commerce.

²⁸ *Id.*

Development Program ("MTDP") (April 1996). MTDP considers minority ownership as ownership of more than 50% of a broadcast corporation's stock, voting control in a broadcast partnership, or ownership of a broadcasting property as an individual proprietor. *Id.* The minority groups included in this report are Black, Hispanic, Asian, and Native American.

²⁰ See Comments of American Women in Radio and Television, Inc. in MM Docket No. 94-149 and MM Docket No. 91-140, at 4 n.4 (filed May 17, 1995), citing 1987 Economic Censuses, *Women-Owned Business*, WB87-1, U.S. Dep't of Commerce, Bureau of the Census, August 1990 (based on 1987 Census). After the 1987 Census report, the Census Bureau did not provide data by particular communications services (four-digit Standard Industrial Classification (SIC) Code), but rather by the general two-digit SIC Code for communications (#48). Consequently, since 1987, the U.S. Census Bureau has not updated data on ownership of broadcast facilities by women, nor does the FCC collect such data. However, we sought comment on whether the Annual Ownership Report Form 323 should be amended to include information on the gender and race of broadcast license owners.

Policies and Rules Regarding Minority and Female Ownership of Mass Media Facilities, Notice of Proposed Rule Making, 10 FCC Rcd 2788, 2797 (1995), 60 FR 06068, February 1, 1995.

²¹ FCC News Release No. 7033, March 6, 1997.

²² The Commission's definition of a small broadcast station for purposes of applying its EEO rule was adopted prior to the requirement of approval by the Small Business Administration pursuant to Section 3(a) of the Small Business Act, 15 U.S.C. 632(a), as amended by section 222 of the Small Business Credit and Business Opportunity Enhancement Act of 1992, Public Law 102-366, section 222(b)(1), 106 Stat. 999 (1992), as further

amended by the Small Business Administration Reauthorization and Amendments Act of 1994, Public Law 103-403, section 301, 108 Stat. 4187 (1994). However, this definition was adopted after public notice and an opportunity for comment. See *Report and Order* in Docket No. 18244, 23 FCC 2d 430 (1970).

²³ See, e.g., 47 CFR 73.3612 (Requirement to file annual employment reports on Form 395-B applies to licensees with five or more full-time employees); *First Report and Order* in Docket No. 21474 (In the Matter of Amendment of Broadcast Equal Employment Opportunity Rules and FCC Form 395), 70 FCC 2d 1466 (1979). The Commission is currently considering how to decrease the administrative burdens imposed by the EEO rule on small stations while maintaining the effectiveness of our broadcast EEO enforcement. *Order and Notice of Proposed Rule Making* in MM Docket No. 96-16 (In the Matter of Streamlining Broadcast EEO Rule and Policies, Vacating the EEO Forfeiture Policy Statement and Amending Section 1.80 of the Commission's Rules to Include EEO Forfeiture Guidelines), 11 FCC Rcd 5154 (1996), 61 FR 9964, March 12, 1996. One option under consideration is whether to define a small station for purposes of affording such relief as one with ten or fewer full-time employees. *Id.* at ¶ 21.

²⁴ We base this estimate on a compilation of 1995 Broadcast Station Annual Employment Reports (FCC Form 395-B), performed by staff of the Equal Opportunity Employment Branch, Mass Media Bureau, FCC.

²⁵ 5 U.S.C. 601(5).

²⁶ *Id.*

PART 2—FREQUENCY ALLOCATIONS AND RADIO TREATY MATTERS; GENERAL RULES AND REGULATIONS

1. The authority citation for part 2 continues to read as follows:

Authority: 47 U.S.C. 154, 302, 303, 307, and 336, unless otherwise noted.

2. Section 2.106, the Table of Frequency Allocations, is amended as follows:

- a. Remove the existing entries for 614–790 MHz and 790–806 MHz.
- b. Add entries in numerical order for 614–746 MHz through 794–806MHz.
- c. In the International Footnotes under heading I., add footnotes S5.293, S5.296, S5.300, S5.309, S5.310, S5.311, S5.312, S5.313, S5.314, S5.315, and S5.316 in numerical order.
- d. In the Non-Government (NG) Footnotes, remove footnotes NG30 and

NG43, revise footnote NG149, and add in numerical order footnotes NG158 and NG159.

The revisions and additions read as follows:

§ 2.106 Table of Frequency Allocations.
* * * * *

International table			United States table		FCC use designators	
Region 1—allocation MHz	Region 2—allocation MHz	Region 3—allocation MHz	Government Allocation MHz	Non-Government Allocation MHz	Rule part(s)	Special-use frequencies
(1)	(2)	(3)	(4)	(5)	(6)	(7)
614–746 BROADCASTING	614–746 BROADCASTING Fixed Mobile	614–746 FIXED MOBILE BROADCASTING	614–746	614–746 BROADCASTING	RADIO BROADCAST (TV) (73) Auxiliary Broadcasting (74)	
S5.296 S5.300 S5.311 S5.312 746–764 BROADCASTING	S5.293 S5.309 S5.310 S5.311 746–764 BROADCASTING Fixed Mobile	S5.311 746–764 FIXED MOBILE BROADCASTING	746–764	NG128 NG149 746–764 FIXED MOBILE BROADCASTING	PRIVATE LAND MOBILE (90) RADIO BROADCAST (TV) (73) WIRELESS COMMUNICATIONS (27) Auxiliary Broadcasting (74)	
S5.296 S5.300 S5.311 S5.312 764–776 BROADCASTING	S5.293 S5.309 S5.310 S5.311 764–776 BROADCASTING Fixed Mobile	S5.311 764–776 FIXED MOBILE BROADCASTING	764–776	NG128 NG159 764–776 FIXED MOBILE	PRIVATE LAND MOBILE (90) Auxiliary Broadcasting (74)	
S5.312 S5.313 S5.314 S5.315 S5.316 776–790 BROADCASTING	S5.293 S5.309 S5.310 776–790 BROADCASTING Fixed Mobile	S5.311 776–790 FIXED MOBILE BROADCASTING	776–790	NG128 NG159 776–790 FIXED MOBILE BROADCASTING	PRIVATE LAND MOBILE (90) RADIO BROADCAST (TV) (73) WIRELESS COMMUNICATIONS (27) Auxiliary Broadcasting (74)	
S5.312 S5.313 S5.314 S5.315 S5.316 790–794 FIXED BROADCASTING	S5.293 S5.309 S5.310 790–794 BROADCASTING Fixed Mobile	S5.311 790–794 FIXED MOBILE BROADCASTING	790–794	NG128 NG158 NG159 790–794 FIXED MOBILE BROADCASTING	PRIVATE LAND MOBILE (90) RADIO BROADCAST (TV) (73) WIRELESS COMMUNICATIONS (27) Auxiliary Broadcasting (74)	

International table			United States table		FCC use designators	
Region 1—allocation MHz	Region 2—allocation MHz	Region 3—allocation MHz	Government	Non-Government	Rule part(s)	Special-use frequencies
(1)	(2)	(3)	Allocation MHz	Allocation MHz		
(1)	(2)	(3)	(4)	(5)	(6)	(7)
S5.312 S5.313 S5.314 S5.315 S5.316	S5.293 S5.309 S5.310 794-806 BROADCASTING Fixed Mobile	S5.311 794-806 FIXED MOBILE BROADCASTING	794-806	NG128 NG159 794-806 FIXED MOBILE	PRIVATE LAND MOBILE (90) Auxiliary Broad- casting (74)	
S5.312 S5.313 S5.314 S5.315 S5.316	S5.293 S5.309 S5.310			NG128 NG158 NG159		

International Footnotes

* * * * *
I. New "S" Numbering Scheme
* * * * *

S5.293 Different category of service: in Chile, Colombia, Cuba, the United States, Guyana, Honduras, Jamaica, Mexico and Panama, the allocation of the bands 470-512 MHz and 614-806 MHz to the fixed and mobile services is on a primary basis, (see No. S5.33), subject to agreement obtained under Article 14/No. S9.21.

S5.296 Additional allocation: in Germany, Austria, Belgium, Cyprus, Denmark, Spain, Finland, France, Ireland, Israel, Italy, Libya, Malta, Morocco, Monaco, Norway, the Netherlands, Portugal, the United Kingdom, Sweden, Switzerland, Swaziland, Syria, Tunisia and Turkey, the band 470-790 MHz is also allocated on a secondary basis to the land mobile service, intended for applications ancillary to broadcasting. Stations of the land mobile service in the countries mentioned in this footnote, shall not cause harmful interference to existing or planned stations operating in accordance with the Table of Frequency Allocations in countries other than those listed in this footnote.

S5.300 Additional allocation: in Israel, Libya, Syria and Sudan, the band 582-790 MHz is also allocated to the fixed and mobile, except aeronautical mobile, services on a secondary basis.

S5.309 Different category of service: in Costa Rica, El Salvador and Honduras, the allocation of the band 614-806 MHz to the fixed service is on a primary basis (see No. S5.33), subject to agreement obtained under Article 14/No. S9.21.

S5.310 Additional allocation: in Cuba, the band 614-890 MHz is also allocated to the radionavigation service on a primary basis, subject to agreement obtained under Article 14/No. S9.21.

S5.311 Within the frequency band 620-790 MHz, assignments may be made to television stations using frequency modulation in the broadcasting-satellite service subject to agreement between the administrations concerned and those having

services, operating in accordance with the Table, which may be affected (see Resolutions 33 and 507). Such stations shall not produce a power flux-density in excess of the value-129 dB(W/m²) for angles of arrival less than 20° (see Recommendation 705) within the territories of other countries without the consent of the administrations of those countries.

S5.312 Additional allocation: in Armenia, Azerbaijan, Belarus, Bulgaria, Georgia, Hungary, Kazakhstan, Latvia, Lithuania, Moldova, Mongolia, Uzbekistan, Poland, Kyrgyzstan, Slovakia, the Czech Republic, Romania, Russia, Tajikistan, Turkmenistan and Ukraine, the band 645-862 MHz is also allocated to the aeronautical radionavigation service on a primary basis.

S5.313 Alternative allocation: in Spain and France, the band 790-830 MHz is allocated to the broadcasting service on a primary basis.

S5.314 Additional allocation: in Austria, Italy, the United Kingdom and Swaziland, the band 790-862 MHz is also allocated to the land mobile service on a secondary basis.

S5.315 Alternative allocation: in Greece, Italy, Morocco and Tunisia, the band 790-838 MHz is allocated to the broadcasting service on a primary basis.

S5.316 Additional allocation: in Germany, Bosnia and Herzegovina, Burkina Faso, Cameroon, Côte d'Ivoire, Croatia, Denmark, Egypt, Finland, Israel, Kenya, The Former Yugoslav Republic of Macedonia, Libya, Liechtenstein, Monaco, Norway, the Netherlands, Portugal, Sweden, Switzerland and Yugoslavia, the band 790-830 MHz, and in these same countries and in Spain, France, Gabon, Malta and Syria, the band 830-862 MHz, are also allocated to the mobile, except aeronautical mobile, service on a primary basis. However, stations of the mobile service in the countries mentioned in connection with each band referred to in this footnote shall not cause harmful interference to, or claim protection from, stations of services operating in accordance with the Table in countries other than those mentioned in connection with the band.

* * * * *

Non-Government (NG) Footnotes

* * * * *
NG149 The frequency bands 54-72 MHz, 76-88 MHz, 174-216 MHz, 470-512 MHz, 512-608 MHz, and 614-746 MHz are also allocated to the fixed service to permit subscription television operations in accordance with Part 73 of the rules.
* * * * *

NG158 The frequency bands 764-776 MHz and 794-806 MHz are available for assignment exclusively to the public safety services, to be defined in Docket No. WT 96-86.

NG159 Full power analog television stations licensed pursuant to applications filed before January 2, 2001, and new digital television (DTV) broadcasting operations in the 746-806 MHz band will be entitled to protection from harmful interference until the end of the DTV transition period. After the end of the DTV transition period, the Commission may assign licenses in the 746-806 MHz band without regard to existing television and DTV operations.

Low power television and television translators in the 746-806 MHz band must cease operations in the band at the end of the DTV transition period.

* * * * *
[FR Doc. 98-2757 Filed 2-9-98; 8:45 am]
BILLING CODE 6712-01-P

ENVIRONMENTAL PROTECTION AGENCY

48 CFR Parts 1515 and 1525

[FRL-5960-1]

Technical Amendments to Acquisition Regulation; Correction of Effective Date Under Congressional Review Act (CRA)

AGENCY: Environmental Protection Agency (EPA).

ACTION: Final rule; correction of effective date under CRA.

SUMMARY: On November 12, 1997 (62 FR 60664), the Environmental Protection Agency published in the **Federal Register** a final rule revising the EPA Acquisition Regulation on calculation of profit or fee, which established an effective date of November 12, 1997. This document corrects the effective date of the rule to February 10, 1998, to be consistent with sections 801 and 808 of the Congressional Review Act (CRA), enacted as part of the Small Business Regulatory Enforcement Fairness Act, 5 U.S.C. 801 and 808.

EFFECTIVE DATE: This rule is effective on February 10, 1998.

FOR FURTHER INFORMATION CONTACT: Judith Koontz, Telephone: (202) 260-9887.

SUPPLEMENTARY INFORMATION:

I. Background

Section 801 of the CRA precludes a rule from taking effect until the agency promulgating the rule submits a rule report, which includes a copy of the rule, to each House of Congress and to the Comptroller General of the General Accounting Office (GAO). EPA recently discovered that it had inadvertently failed to submit the above rule as required; thus, although the rule was promulgated on November 12, 1997 (62 FR 60664) by operation of law, the rule did not take effect on November 12, 1997, as stated therein. Now that EPA has discovered its error, the rule is being submitted to both Houses of Congress and the GAO. This document amends the effective date of the rule consistent with the provisions of the CRA.

Section 553 of the Administrative Procedure Act, 5 U.S.C. 553(b)(B), provides that, when an agency for good cause finds that notice and public procedure are impracticable, unnecessary or contrary to the public interest, an agency may issue a rule without providing notice and an opportunity for public comment. EPA has determined that there is good cause for making today's rule final without prior proposal and opportunity for comment because EPA merely is correcting the effective date of the promulgated rule to be consistent with the congressional review requirements of the Congressional Review Act as a matter of law and has no discretion in this matter. Thus, notice and public procedure are unnecessary. The Agency finds that this constitutes good cause under 5 U.S.C. 553(b)(B). Moreover, since today's action does not create any new regulatory requirements and

affected parties have known of the underlying rule since November 12, 1997, EPA finds that good cause exists to provide for an immediate effective date pursuant to 5 U.S.C. 553(d)(3) and 808(2).

II. Administrative Requirements

Under Executive Order 12866 (58 FR 51735, October 4, 1993), this action is not a "significant regulatory action" and is therefore not subject to review by the Office of Management and Budget. In addition, this action does not impose any enforceable duty or contain any unfunded mandate as described in the Unfunded Mandates Reform Act of 1995 (Pub. L. 104-4), or require prior consultation with State officials as specified by Executive Order 12875 (58 FR 58093, October 28, 1993), or involve special consideration of environmental justice related issues as required by Executive Order 12898 (59 FR 7629, February 16, 1994). Because this action is not subject to notice-and-comment requirements under the Administrative Procedure Act or any other statute, it is not subject to the regulatory flexibility provisions of the Regulatory Flexibility Act (5 U.S.C. 601 *et seq.*). EPA's compliance with these statutes and Executive Orders for the underlying rule is discussed in November 12, 1997, **Federal Register** document.

Pursuant to 5 U.S.C. 801(a)(1)(A), as added by the Small Business Regulatory Enforcement Fairness Act of 1996, EPA will submit a report containing this rule and other required information to the U.S. Senate, the U.S. House of Representatives and the Comptroller General of the General Accounting Office; however, in accordance with 5 U.S.C. 808(2), this rule is effective on February 10, 1998. This rule is not a "major rule" as defined in 5 U.S.C. 804(2).

This final rule only amends the effective date of the underlying rule; it does not amend any substantive requirements contained in the rule. Accordingly, to the extent it is available, judicial review is limited to the amended effective date.

Dated: January 30, 1998.

Carol Browner,
Administrator.

[FR Doc. 98-3020 Filed 2-9-98; 8:45 am]

BILLING CODE 6560-50-M

ENVIRONMENTAL PROTECTION AGENCY

48 CFR Part 1552

[FRL-5959-9]

Technical Amendments to Acquisition Regulation; Coverage on Information Resources Management (IRM); Correction of Effective Date Under Congressional Review Act (CRA)

AGENCY: Environmental Protection Agency (EPA).

ACTION: Final rule; correction of effective date under CRA.

SUMMARY: On June 28, 1996 (61 FR 33693), the Environmental Protection Agency published in the **Federal Register** a final rule amending its Acquisition Regulation coverage on Information Resources Management (IRM) by providing electronic access to EPA IRM policies for the Agency's contractors, which established an effective date of July 15, 1996. This document corrects the effective date of the rule to February 10, 1998, to be consistent with sections 801 and 808 of the Congressional Review Act (CRA), enacted as part of the Small Business Regulatory Enforcement Fairness Act, 5 U.S.C. 801 and 808.

EFFECTIVE DATE: This rule is effective on February 10, 1998.

FOR FURTHER INFORMATION CONTACT: Edward N. Chambers at (202) 260-6028.

SUPPLEMENTARY INFORMATION:

I. Background

Section 801 of the CRA precludes a rule from taking effect until the agency promulgating the rule submits a rule report, which includes a copy of the rule, to each House of Congress and the Comptroller General of the General Accounting Office (GAO). EPA recently discovered that it had inadvertently failed to submit the above rule as required; thus, although the rule was promulgated on June 28, 1996 (61 FR 33693) by operation of law, the rule did not take effect on July 15, 1996, as stated therein. Now that EPA has discovered its error, the rule is being submitted to both Houses of Congress and the GAO. This document amends the effective date of the rule consistent with the provisions of the CRA.

Section 553 of the Administrative Procedure Act, 5 U.S.C. 553(b)(B), provides that, when an agency for good cause finds that notice and public procedure are impracticable, unnecessary or contrary to the public interest, an agency may issue a rule without providing notice and an

opportunity for public comment. EPA has determined that there is good cause for making today's rule final without prior proposal and opportunity for comment because EPA merely is correcting the effective date of the promulgated rule to be consistent with the congressional review requirements of the Congressional Review Act as a matter of law and has no discretion in this matter. Thus, notice and public procedure are unnecessary. The Agency finds that this constitutes good cause under 5 U.S.C. 553(b)(B). Moreover, since today's action does not create any new regulatory requirements and affected parties have known of the underlying rule since June 28, 1996, EPA finds that good cause exists to provide for an immediate effective date pursuant to 5 U.S.C. 553(d)(3) and 808(2).

II. Administrative Requirements

Under Executive Order 12866 (58 FR 51735, October 4, 1993), this action is not a "significant regulatory action" and is therefore not subject to review by the Office of Management and Budget. In addition, this action does not impose any enforceable duty or contain any unfunded mandate as described in the Unfunded Mandates Reform Act of 1995 (Pub. L. 104-4), or require prior consultation with State officials as specified by Executive Order 12875 (58 FR 58093, October 28, 1993), or involve special consideration of environmental justice related issues as required by Executive Order 12898 (59 FR 7629, February 16, 1994). Because this action is not subject to notice-and-comment requirements under the Administrative Procedure Act or any other statute, it is not subject to the regulatory flexibility provisions of the Regulatory Flexibility Act (5 U.S.C. 601 *et seq.*). EPA's compliance with these statutes and Executive Orders for the underlying rule is discussed in June 28, 1996, **Federal Register** document.

Pursuant to 5 U.S.C. 801(a)(1)(A), as added by the Small Business Regulatory Enforcement Fairness Act of 1996, EPA will submit a report containing this rule and other required information to the U.S. Senate, the U.S. House of Representatives and the Comptroller General of the General Accounting Office; however, in accordance with 5 U.S.C. 808(2), this rule is effective on February 10, 1998. This rule is not a "major rule" as defined in 5 U.S.C. 804(2).

This final rule only amends the effective date of the underlying rule; it does not amend any substantive requirements contained in the rule. Accordingly, to the extent it is available,

judicial review is limited to the amended effective date.

Dated: January 30, 1998.

Carol Browner,
Administrator.

[FR Doc. 98-3031 Filed 2-9-98; 8:45 am]

BILLING CODE 6560-50-M

DEPARTMENT OF TRANSPORTATION

Research and Special Programs Administration

49 CFR Part 195

[Docket No. PS-121; Notice-2]

RIN 2137-AB46

Pressure Testing Older Hazardous Liquid and Carbon Dioxide Pipelines

AGENCY: Research and Special Programs Administration (RSPA), DOT.

ACTION: Response to petitions for reconsideration; request for comments.

SUMMARY: On June 7, 1994, RSPA issued a final rule amending existing regulations for liquid and carbon dioxide pipeline facilities. The rule required the hydrostatic pressure testing of certain older pipelines that were never pressure tested to current standards. The American Petroleum Institute (Petitioner or API) and Williams Pipe Line Company (Petitioner or Williams) filed Petitions for Reconsideration (petitions) concerning certain provisions of the final rule. In response to these petitions, this document clarifies certain provisions of the final rule and seeks comments on one issue.

DATES: Interested persons are invited to submit comments on this notice by April 13, 1998. Late filed comments will be considered to the extent practicable.

ADDRESSES: Written comments must be submitted in duplicate and mailed or hand-delivered to the OPS, Room 2335, U.S. Department of Transportation, 400 Seventh Street, SW., Washington, DC 20590-0001. Identify the docket and notice number stated in the heading of this notice. Alternatively, comments may be submitted via e-mail to "ops.comments@rspa.dot.gov". Comments will become part of this docket and will be available for inspection or copying in Room 2335 between 8:30 a.m. and 5:00 p.m. each business day.

FOR FURTHER INFORMATION CONTACT: Mike Israni, (202) 366-4571, or e-mail: mike.israni@rspa.dot.gov, regarding the subject matter of this document, or OPS (202) 366-4046, for copies of this

petition document or other material in the docket.

SUPPLEMENTARY INFORMATION:

Background

The purpose of the pressure testing rule (59 FR 29379; June 7, 1994) is to ensure that certain older hazardous liquid and carbon dioxide pipelines have an adequate safety margin between their maximum operating pressure and test pressure. The rule applied to those pipelines never pressure tested according to current standards. The compliance dates for pressure testing the older pipelines have been extended. (62 FR 54591; October 21, 1997). The extension is to allow for consideration of rulemaking providing an alternative to pressure testing in certain circumstances. This alternative to pressure testing is based on a petition from API.

In its petitions for reconsideration of the final rule, API raised three issues and Williams raised two issues. The most significant issue raised by both API and Williams related to the prohibition of testing with petroleum. The pressure testing rule prohibited the use of petroleum as a test medium in pressure testing such pipelines. RSPA withdrew the prohibition by amendment of the pressure testing rule on August 11, 1994 in the **Federal Register** (59 FR 41259).

Remaining Issues in Petitions

Disposal of Test Water

API asserted that the final rule did not adequately address its comments concerning problems with obtaining permits to acquire and dispose of test water. API reiterated concerns raised in its comments submitted during the pressure testing rulemaking comment period. Specifically, API asked that RSPA issue administrative procedures, perhaps in conjunction with the Environmental Protection Agency (EPA), that would facilitate the process of obtaining permits to acquire and dispose of test water. In its petition, API claimed that RSPA's coordination effort "has not reached the appropriate persons within EPA so that it has any impact on the ability of an operator to obtain a permit or waiver." Furthermore, API stated that some of its member companies have been attempting to get EPA's attention on the subject of permits for hydrostatic test water for several years with little success. API claimed that member companies in EPA Region VI have experienced "delays of years in obtaining permits, with some permits never issued." API stated that, because

Texas and Louisiana do not have EPA approved state programs for issuing EPA disposal permits, operators must obtain permits from both the state and EPA in Texas and Louisiana (both in EPA Region VI). In addition, API claimed that its member companies have experienced similar delays in obtaining water disposal permits in other EPA regions. As a result, API asserted that operators will not be able to obtain such permits, and will be unable to schedule testing to meet the compliance deadlines established in the final rule.

Response—RSPA has written to the Assistant Administrator for Water requesting that EPA give prompt attention to requests from operators for National Pollutants Discharge Elimination System (NPDES) permits to dispose of test water used to comply with the final rule. We have provided EPA headquarters with information regarding delays in issuing permits. RSPA believes that EPA will provide permits to dispose of test water. If an operator cannot obtain such a permit, this would be a basis for a waiver request. In addition, as already noted, RSPA intends to publish an NPRM on an alternative to pressure testing in the near future. If adopted, the alternative would at times allow an operator to elect a means of ensuring the integrity of its pipeline other than pressure testing. This would avoid the need to dispose of test water.

Inert Gas as Test Medium

Petitioner asserts that the final rule results in the prohibition of any test medium other than water, although some companies use inert gas to test short segments of line. API states that inert gas testing accomplishes the same purpose as hydrotesting.

Response—The use of inert gas in lieu of water or liquid petroleum as test medium was not raised in the proposed rulemaking. Therefore, we can not address it in this response to petition for reconsideration of the pressure test rule. However, § 195.306(c) allows, under specified conditions, the use of inert gas or carbon dioxide as a test medium rather than water or petroleum for

carbon dioxide pipelines. Further, § 195.306(d) permits the use of air or inert gas as the test medium in low-stress pipelines.

Terminal Piping

Williams disagreed that piping systems within terminals need to be tested. Terminal piping includes receiving and reinjection lines, both connected by piping to breakout tanks. Williams believes that terminal piping systems should be exempt from the testing requirements of the regulation. Williams' position is that the final rule was issued to test older high pressure "pipes" in cross-country pipelines. Williams offered the following reasons not to test such systems.

1. Williams' low pressure piping systems operate below 275 psi, below 20 percent of specified minimum yield strength (SMYS).

2. The ERW or seamless piping in the low-pressure systems are generally Grade B pipe of standard wall construction in pipe sizes of 6, 8, 10, and 12 inch diameter with maximum operating pressures (MOP) of 2130, 1881, 1711, and 1482 psi, respectively.

3. These low-pressure piping systems have series 150 American National Standard Institute (ANSI) flanges good only for 275 psi MOP, well under 20 percent SMYS.

4. These low-pressure piping systems are protected by full-flow low pressure manifold relief systems set to operate at 275 psi in accordance with 49 CFR § 195.406(b).

5. A one-time pressure leak test provides an insignificant amount of protection for the public safety and the environment.

6. Williams has no records of any seam failures occurring in ERW pipe within its terminal boundaries.

Response—In another final rule issued after Williams filed the petition for reconsideration (Transportation of Hazardous Liquids at 20 percent or Less of Specified Minimum Yield Strength (59 FR 35465; July 12, 1994)), RSPA extended Part 195 to cover certain previously unregulated low-stress pipelines. (These did not include piping

in terminal areas which are addressed in the Williams petition.) However, RSPA did not apply the pressure testing requirements of Subpart E to these previously unregulated low-stress pipelines except for replacements, relocations, and lines carrying highly volatile liquids (HVL).

The piping at Williams' terminal is designed with relief valves which ensure that the piping will never experience pressure at or exceeding 20% SMYS. If the same rationale used in the low-stress pipeline rule is applied, pressure testing may not be needed for safety as long as the piping does not transport HVL. However, RSPA wants to explore this issue further by inviting comments from the public on the following issues:

(1) Should a segment of pipeline system (such as pipeline within terminal, or tank farm) which is designed and operated so that stress levels can never exceed 20% SMYS qualify for an exemption from pressure testing?

(2) Should we require pressure testing of piping in terminals and tank farms based on risk (considering such risk factors as location, history of corrosion leaks, weld type, underground or above ground terminal piping, percentage of lines under corrosion protection, etc.)?

As noted above, the requirement for pressure testing has been stayed to allow completion of rulemaking on a risk-based approach to pressure testing. This stay should provide sufficient time for RSPA to evaluate comments received in response to this request and to decide on a course of action. In any case, until these comments are evaluated and a course of action is decided on, RSPA will not enforce the requirement for pressure testing within terminal areas that are designed and operated so that stress levels can never exceed 20% SMYS.

Issued in Washington D.C. on February 5, 1998.

Richard B. Felder,
Associate Administrator for Pipeline Safety.
[FR Doc. 98-3345 Filed 2-9-98; 8:45 am]

BILLING CODE 4910-00-P

Proposed Rules

Federal Register

Vol. 63, No. 27

Tuesday, February 10, 1998

This section of the FEDERAL REGISTER contains notices to the public of the proposed issuance of rules and regulations. The purpose of these notices is to give interested persons an opportunity to participate in the rule making prior to the adoption of the final rules.

DEPARTMENT OF AGRICULTURE

Agricultural Marketing Service

7 CFR Parts 911 and 915

[Docket No. FV98-911-1 PR]

Limes and Avocados Grown in Florida; Establishment of a Continuing Assessment Rate for Limes and a Decrease in the Continuing Assessment Rate for Avocados

AGENCY: Agricultural Marketing Service, USDA.

ACTION: Proposed rule.

SUMMARY: This rule would establish an assessment rate for the Lime Administrative Committee (LAC) under Marketing Order No. 911 for the 1998-99 and subsequent fiscal years and decrease the assessment rate established for the Avocado Administrative Committee (AAC) under Marketing Order No. 915 for the 1998-99 and subsequent fiscal years. The Lime and Avocado Administrative Committees (Committees) are responsible for local administration of the marketing orders which regulate the handling of limes and avocados grown in Florida. Authorization to assess lime and avocado handlers enables the Committees to incur expenses that are reasonable and necessary to administer the programs. The fiscal years begin April 1 and end March 31. The assessment rates would remain in effect indefinitely unless modified, suspended, or terminated.

DATES: Comments must be received by March 12, 1998.

ADDRESSES: Interested persons are invited to submit written comments concerning this rule. Comments must be sent in triplicate to the Docket Clerk, Fruit and Vegetable Programs, AMS, USDA, room 2525-S, P.O. Box 96456, Washington, DC 20090-6456; Fax: (202) 205-6632. Comments should reference the docket number and the date and page number of this issue of the **Federal Register** and will be available for public

inspection in the Office of the Docket Clerk during regular business hours.

FOR FURTHER INFORMATION CONTACT: Doris Jamieson, Southeast Marketing Field Office, Fruit and Vegetable Programs, AMS, USDA, P.O. Box 2276, Winter Haven, FL 33883-2276; telephone: (941) 299-4770, Fax: (941) 299-5169; or George Kelhart, Technical Advisor, Marketing Order Administration Branch, Fruit and Vegetable Programs, AMS, USDA, room 2525-S, P.O. Box 96456, Washington, DC 20090-6456; telephone: (202) 720-2491, Fax: (202) 205-6632. Small businesses may request information on compliance with this regulation by contacting Jay Guerber, Marketing Order Administration Branch, Fruit and Vegetable Programs, AMS, USDA, room 2525-S, P.O. Box 96456, Washington, DC 20090-6456; telephone: (202) 720-2491, Fax: (202) 205-6632.

SUPPLEMENTARY INFORMATION: This rule is issued under Marketing Agreement No. 126 and Marketing Order No. 911, both as amended (7 CFR part 911), regulating the handling of limes grown in Florida, and Marketing Agreement No. 121 and Marketing Order No. 915, both as amended (7 CFR part 915), regulating the handling of avocados grown in Florida, hereinafter referred to as the "orders." The marketing agreements and orders are effective under the Agricultural Marketing Agreement Act of 1937, as amended (7 U.S.C. 601-674), hereinafter referred to as the "Act."

The Department of Agriculture (Department) is issuing this rule in conformance with Executive Order 12866.

This rule has been reviewed under Executive Order 12988, Civil Justice Reform. Under the marketing orders now in effect, Florida lime and avocado handlers are subject to assessments. Funds to administer the orders are derived from such assessments. It is intended that the assessment rates as issued herein would be applicable to all assessable limes and avocados beginning April 1, 1998, and continue until amended, suspended, or terminated. This rule would not preempt any State or local laws, regulations, or policies, unless they present an irreconcilable conflict with this rule.

The Act provides that administrative proceedings must be exhausted before

parties may file suit in court. Under section 608c(15)(A) of the Act, any handler subject to an order may file with the Secretary a petition stating that the order, any provision of the order, or any obligation imposed in connection with the order is not in accordance with law and request a modification of the order or to be exempted therefrom. Such handler is afforded the opportunity for a hearing on the petition. After the hearing the Secretary would rule on the petition. The Act provides that the district court of the United States in any district in which the handler is an inhabitant, or has his or her principal place of business, has jurisdiction to review the Secretary's ruling on the petition, provided an action is filed not later than 20 days after the date of the entry of the ruling.

This rule would establish an assessment rate for the LAC for the 1998-99 and subsequent fiscal years of \$0.16 per bushel container. This rule would also decrease the assessment rate established for the AAC for the 1998-99 and subsequent fiscal years from \$0.16 per bushel container to \$0.08 per bushel container.

The Florida lime and avocado marketing orders provide authority for the Committees, with the approval of the Department, to formulate an annual budget of expenses and collect assessments from handlers to administer the programs. The members of the Committees are producers and handlers of Florida limes and avocados. They are familiar with the Committees' needs and with the costs for goods and services in their local areas and are thus in a position to formulate appropriate budgets and assessment rates. The assessment rates are formulated and discussed in public meetings. Thus, all directly affected persons have an opportunity to participate and provide input.

For the 1996-97 and subsequent fiscal years, the AAC recommended, and the Department approved, an assessment rate that would continue in effect from fiscal year to fiscal year indefinitely unless modified, suspended, or terminated by the Secretary upon recommendation and information submitted by the Committee or other information available to the Secretary. The LAC has not assessed handlers since the 1995-96 fiscal year. It has

used reserve funds to cover authorized expenses.

The Committees met on December 10, 1997, and the LAC unanimously recommended 1998-99 expenditures of \$130,785 and an assessment rate of \$0.16 per bushel container of limes. The AAC also met on December 10, 1997, and unanimously recommended 1998-99 expenditures of \$166,844 and an assessment rate of \$0.08 per bushel container of avocados.

In comparison, last year's budgeted expenditures were \$101,630 for the LAC and \$123,000 for the AAC. The assessment rate for the LAC of \$0.16 is the same as the rate established for the 1995-96 fiscal year, the last year handlers were assessed. The assessment rate for the AAC of \$0.08 is \$0.08 lower than the rate currently in effect.

In an effort to reduce industry costs and assist with the recovery from Hurricane Andrew which hit southern Florida in August of 1992, the LAC has been operating from its reserve funds for the past two years. With the lime industry beginning to recover and reserve funds reduced, the LAC voted to establish an assessment rate to cover operating expenses.

The AAC has excess reserve funds. They voted to decrease the assessment rate and use reserve funds to cover operating expenses and reduce reserve levels.

The major expenditures recommended by the LAC for the 1998-99 year include \$46,000 for salaries, \$25,000 for local and national enforcement, \$9,448 for employee benefits, \$9,000 for research, \$8,287 for insurance and bonds, and \$4,500 for travel. The LAC budgeted expenses for these items in 1997-98 were \$40,000, \$15,595, \$5,500, \$5,000, \$0, and \$3,000, respectively.

The major expenditures recommended by the AAC for the 1998-99 year include \$46,000 for salaries, \$34,000 for research, \$32,000 for local and national enforcement, \$9,778 for employee benefits, \$8,516 for insurance and bonds, and \$7,000 for travel. The AAC budget expenses for these items in 1997-98 were \$40,000, \$7,000, \$26,595, \$6,380, \$7,937, and \$7,000, respectively.

The assessment rates recommended by the Committees were derived by dividing anticipated expenses by expected shipments of Florida limes and avocados. Lime shipments for the year are estimated at 600,000 bushel containers which should provide \$96,000 in assessment income. Avocado shipments for the year are estimated at 90,000 bushel containers which should provide \$72,000 in assessment income. Income derived from handler

assessments, along with interest income and funds from the Committees' authorized reserves, would be adequate to cover budgeted expenses. Funds in the reserves would be kept within the maximum permitted by the orders. (\$911.42 and 915.42—three fiscal years' operational expenses). Reserves for limes are currently around \$100,000, and reserves for avocados stand at around \$250,000.

The proposed assessment rates would continue in effect indefinitely unless modified, suspended, or terminated by the Secretary upon recommendation and information submitted by the Committees or other available information.

Although these assessment rates are effective for an indefinite period, the Committees will continue to meet prior to or during each fiscal year to recommend budgets of expenses and consider recommendations for modification of the assessment rates. The dates and times of Committee meetings are available from the Committees or the Department. Committee meetings are open to the public and interested persons may express their views at these meetings. The Department will evaluate Committee recommendations and other available information to determine whether modification of the assessment rates are needed. Further rulemaking will be undertaken as necessary. The Committees' 1998-99 budgets and those for subsequent fiscal years will be reviewed and, as appropriate, approved by the Department.

Pursuant to requirements set forth in the Regulatory Flexibility Act (RFA), the Agricultural Marketing Service (AMS) has considered the economic impact of this rule on small entities. Accordingly, AMS has prepared this initial regulatory flexibility analysis.

The purpose of the RFA is to fit regulatory actions to the scale of business subject to such actions in order that small businesses will not be unduly or disproportionately burdened. Marketing orders issued pursuant to the Act, and the rules issued thereunder, are unique in that they are brought about through group action of essentially small entities acting on their own behalf. Thus, both statutes have small entity orientation and compatibility.

There are approximately 111 producers of limes and 141 producers of avocados in the production area and approximately 33 lime handlers and 49 avocado handlers subject to regulation under the marketing orders. Small agricultural producers have been defined by the Small Business Administration (13 CFR 121.601) as

those having annual receipts less than \$500,000, and small agricultural service firms are defined as those whose annual receipts are less than \$5,000,000.

Based on the Florida Agricultural Statistical Service and Committee data, the average price for fresh limes during the 1995-96 season was \$8.05 per 88 pound box equivalent and total shipments were 371,413 bushels. Approximately 20 percent of all handlers handled 86 percent of Florida lime shipments. The average price for fresh avocados during the 1996-97 season was \$13.20 per 55 pound bushel box equivalent for all domestic shipments and the total shipments were 917,861 bushels. Approximately 10 percent of all handlers handled 90 percent of Florida avocado shipments. Many lime and avocado handlers ship other tropical fruit and vegetable products which are not included in the committee data but would contribute further to handler receipts.

Using the average prices, about 90 percent of lime and avocado handlers could be considered small businesses under the SBA definition and about 10 percent of the handlers could be considered large businesses. The majority of Florida lime and avocado producers and handlers may be classified as small entities.

This rule would establish an assessment rate for the LAC and collected from handlers for the 1998-99 and subsequent fiscal years of \$0.16 per bushel container. The LAC unanimously recommended 1998-99 expenditures of \$130,785 and an assessment rate of \$0.16 per bushel container for 1998-99 and subsequent fiscal years. The assessment rate of \$0.16 is the same as the rate established for the 1995-96 fiscal year, the last year handlers were assessed. The quantity of assessable limes for the 1998-99 fiscal year is estimated at 600,000 containers. Thus, the \$0.16 rate for limes should provide \$96,000 in assessment income. The assessment income, along with interest income and funds from the Committee's authorized reserve, would be adequate to cover budgeted expenses for 1998-99.

This rule would also decrease the assessment rate established for the AAC and collected from handlers for the 1998-99 and subsequent fiscal years from \$0.16 per bushel container to \$0.08 per bushel container. The AAC unanimously recommended 1998-99 expenditures of \$166,844 and an assessment rate of \$0.08 per bushel container of avocados. The assessment rate of \$0.08 is \$0.08 lower than the 1997-98 rate. The quantity of assessable avocados for the 1998-99 fiscal year is estimated at 900,000 containers. Thus,

the \$0.08 rate for avocados should provide \$72,000 in assessment income. The assessment income, along with interest income and funds from the Committee's authorized reserve, would be adequate to cover budgeted expenses.

Due to the devastation of Hurricane Andrew in August of 1992, the LAC has been operating from its reserve funds for the past two years. The industry has now adequately recovered from the loss. In order not to deplete reserve funds further, the LAC voted to establish an assessment rate for 1998-99 and subsequent fiscal years. The assessments, along with interest income and reserves, would cover committee operating expenses.

The AAC has a surplus in its reserve fund. The AAC voted to decrease the assessment rate and use funds from the reserves. The assessments, along with interest income and reserves, would cover committee operating expenses.

The LAC reviewed and unanimously recommended 1998-99 expenditures of \$130,785 which include increases in salaries, office space, aerial photo/tree count, and office equipment. The AAC reviewed and unanimously recommended 1998-99 expenditures of \$166,844 which include increases in salaries, office space, and aerial photo/tree count. Prior to arriving at this budget, the Committees considered information from various sources, such as the Committees' Budget Subcommittee. Alternative expenditure levels were discussed by these groups, based upon the relative value of various research projects to the lime and avocado industries. The LAC budgeted \$9,000 and the AAC budgeted \$34,000 for research.

The assessment rate of \$0.16 per bushel container of assessable limes was then determined by dividing the total recommended budget by the quantity of assessable limes, estimated at 600,000 bushel containers for the 1998-99 fiscal year. This is approximately \$35,000 below the anticipated expenses, which the LAC determined to be acceptable. The assessment rate of \$0.08 per bushel container of assessable avocados was then determined by dividing the total recommended budget by the quantity of assessable avocados, estimated at 900,000 bushel containers for the 1998-99 fiscal year. This is approximately \$171,000 below the anticipated expenses, which the AAC determined to be acceptable.

A review of historical information indicates that the grower price for the 1998-99 season could range between \$4.16 and \$9.50 per container of limes. Therefore, the estimated assessment revenue for the 1998-99 crop year as a

percentage of total grower revenue could range between 1.6 and 3.8 percent.

A review of historical information indicates that the grower price for the 1998-99 season could range between \$13.20 and \$14.90 per container of avocados. Therefore, the estimated assessment revenue for the 1998-99 crop year as a percentage of total grower revenue could range between .5 and .6 percent.

This action would increase the assessment obligation imposed on lime handlers and decrease the assessment obligation imposed on avocado handlers. While assessments impose some additional costs on handlers, the costs are minimal and uniform on all handlers. Some of the additional costs may be passed on to producers. However, these costs would be offset by the benefits derived by the operation of the marketing orders. In addition, the Committees' meetings were widely publicized throughout the Florida lime and avocado industries and all interested persons were invited to attend the meetings and participate in deliberations on all issues. Like all LAC and AAC meetings, the December 10, 1997, meetings were public meetings and all entities, both large and small, were able to express views on this issue. Finally, interested persons are invited to submit information on the regulatory and informational impacts of this action on small businesses.

This proposed rule would impose no additional reporting or recordkeeping requirements on either small or large Florida lime and avocado handlers. As with all Federal marketing order programs, reports and forms are periodically reviewed to reduce information requirements and duplication by industry and public sector agencies.

The Department has not identified any relevant Federal rules that duplicate, overlap, or conflict with this rule.

A 30-day comment period is provided to allow interested persons to respond to this proposed rule. Thirty days is deemed appropriate because: (1) The Committees need to have sufficient funds to pay expenses which are incurred on a continuous basis; (2) the 1998-99 fiscal years begin on April 1, 1998, and the orders require that the rates of assessment for each fiscal year apply to all assessable limes and avocados handled during such fiscal years; and (3) handlers are aware of this action which was unanimously recommended by the Committees at a public meeting and is similar to other

assessment rate actions issued in past years.

List of Subjects

7 CFR Part 911

Limes, Marketing agreements, Reporting and recordkeeping requirements.

7 CFR Part 915

Avocados, Marketing agreements, Reporting and recordkeeping requirements.

For the reasons set forth in the preamble, 7 CFR parts 911 and 915 are proposed to be amended as follows:

1. The authority citation for both 7 CFR parts 911 and 915 continues to read as follows:

Authority: 7 U.S.C. 601-674.

PART 911—LIMES GROWN IN FLORIDA

2. A new subpart titled "Assessment Rates" and a new § 911.234 are proposed to be added to read as follows:

Note: This section will appear in the Code of Federal Regulations.

Subpart—Assessment Rates

§ 911.234 Assessment rate.

On and after April 1, 1998, an assessment rate of \$0.16 per bushel container is established for Florida limes.

PART 915—AVOCADOS GROWN IN SOUTH FLORIDA

3. A new subpart titled "Assessment Rates" is proposed to be added and § 915.235 is proposed to be revised to read as follows:

Note: This section will appear in the Code of Federal Regulations.

Subpart—Assessment Rates

§ 915.235 Assessment rate.

On and after April 1, 1998, as assessment rate of \$0.08 per bushel container is established for South Florida avocados.

Dated: February 4, 1998.

Robert C. Keeney,
Deputy Administrator, Fruit and Vegetable Programs.

[FR Doc. 98-3286 Filed 2-9-98; 8:45 am]

BILLING CODE 3410-02-P

DEPARTMENT OF TRANSPORTATION

Federal Aviation Administration

14 CFR Part 39

[Docket No. 97-NM-226-AD]

RIN 2120-AA64

Airworthiness Directives; British Aerospace BAe Model ATP Airplanes

AGENCY: Federal Aviation Administration, DOT.

ACTION: Notice of proposed rulemaking (NPRM).

SUMMARY: This document proposes the adoption of a new airworthiness directive (AD) that is applicable to certain British Aerospace BAe Model ATP airplanes. This proposal would require repetitive inspections to detect corrosion of the brake hydraulic accumulators in the vicinity of the mounting straps; and corrective actions, if necessary. This proposal is prompted by issuance of mandatory continuing airworthiness information by a foreign civil airworthiness authority. The actions specified by the proposed AD are intended to detect and correct corrosion of the brake hydraulic accumulators, which could lead to loss of hydraulic pressure and consequent loss of braking capability of the airplane.

DATES: Comments must be received by March 12, 1998.

ADDRESSES: Submit comments in triplicate to the Federal Aviation Administration (FAA), Transport Airplane Directorate, ANM-114, Attention: Rules Docket No. 97-NM-226-AD, 1601 Lind Avenue, SW., Renton, Washington 98055-4056. Comments may be inspected at this location between 9:00 a.m. and 3:00 p.m., Monday through Friday, except Federal holidays.

The service information referenced in the proposed rule may be obtained from AI(R) American Support, Inc., 13850 Mcclarean Road, Herndon, Virginia 20171. This information may be examined at the FAA, Transport Airplane Directorate, 1601 Lind Avenue, SW., Renton, Washington.

FOR FURTHER INFORMATION CONTACT: Norman B. Martenson, Manager, International Branch, ANM-116, FAA, Transport Airplane Directorate, 1601 Lind Avenue, SW., Renton, Washington 98055-4056; telephone (425) 227-2110; fax (425) 227-1149.

SUPPLEMENTARY INFORMATION:**Comments Invited**

Interested persons are invited to participate in the making of the

proposed rule by submitting such written data, views, or arguments as they may desire. Communications shall identify the Rules Docket number and be submitted in triplicate to the address specified above. All communications received on or before the closing date for comments, specified above, will be considered before taking action on the proposed rule. The proposals contained in this notice may be changed in light of the comments received.

Comments are specifically invited on the overall regulatory, economic, environmental, and energy aspects of the proposed rule. All comments submitted will be available, both before and after the closing date for comments, in the Rules Docket for examination by interested persons. A report summarizing each FAA-public contact concerned with the substance of this proposal will be filed in the Rules Docket.

Commenters wishing the FAA to acknowledge receipt of their comments submitted in response to this notice must submit a self-addressed, stamped postcard on which the following statement is made: "Comments to Docket Number 97-NM-226-AD." The postcard will be date stamped and returned to the commenter.

Availability of NPRMs

Any person may obtain a copy of this NPRM by submitting a request to the FAA, Transport Airplane Directorate, ANM-114, Attention: Rules Docket No. 97-NM-226-AD, 1601 Lind Avenue, SW., Renton, Washington 98055-4056.

Discussion

The Civil Aviation Authority (CAA), which is the airworthiness authority for the United Kingdom, notified the FAA that an unsafe condition may exist on certain British Aerospace BAe Model ATP airplanes. The CAA advises that it has received two reports indicating that corrosion was found on the main hydraulic accumulator of an airplane having a similar hydraulic system installation to that of BAe Model ATP airplanes. Both the brake hydraulic accumulators and the main hydraulic accumulators on these airplanes are manufactured by the same vendor, and use the same type of protective treatment for corrosion; therefore, the brake hydraulic accumulators of BAe Model ATP airplanes could also be subject to corrosion. Such corrosion of the brake hydraulic accumulators, if not detected and corrected in a timely manner, could lead to loss of hydraulic pressure and consequent loss of braking capability of the airplane.

Explanation of Relevant Service Information

The manufacturer has issued British Aerospace Service Bulletin ATP-32-80, Revision 1, dated July 9, 1997, which describes procedures for repetitive inspections of the brake hydraulic accumulators for corrosion, in the vicinity of the mounting straps. The service bulletin also describes procedures for removal of any light surface corrosion found, application of protective treatment and restoration of the paint finish; and/or, replacement of the accumulators with serviceable parts; if necessary. The CAA classified this service bulletin as mandatory and issued British airworthiness directive 004-06-97 in order to assure the continued airworthiness of these airplanes in the United Kingdom.

FAA's Conclusions

This airplane model is manufactured in the United Kingdom and is type certificated for operation in the United States under the provisions of section 21.29 of the Federal Aviation Regulations (14 CFR 21.29) and the applicable bilateral airworthiness agreement. Pursuant to this bilateral airworthiness agreement, the CAA has kept the FAA informed of the situation described above. The FAA has examined the findings of the CAA, reviewed all available information, and determined that AD action is necessary for products of this type design that are certificated for operation in the United States.

Explanation of Requirements of Proposed Rule

Since an unsafe condition has been identified that is likely to exist or develop on other airplanes of the same type design registered in the United States, the proposed AD would require accomplishment of the actions specified in the service bulletin described previously.

Cost Impact

The FAA estimates that 10 British Aerospace BAe Model ATP airplanes of U.S. registry would be affected by this proposed AD, that it would take approximately 2 work hours per airplane to accomplish the proposed inspection, and that the average labor rate is \$60 per work hour. Based on these figures, the cost impact of the proposed AD on U.S. operators is estimated to be \$1,200, or \$120 per airplane, per inspection cycle.

The cost impact figure discussed above is based on assumptions that no operator has yet accomplished any of the proposed requirements of this AD action, and that no operator would accomplish those actions in the future if this AD were not adopted.

Regulatory Impact

The regulations proposed herein would not have substantial direct effects on the States, on the relationship between the national government and the States, or on the distribution of power and responsibilities among the various levels of government. Therefore, in accordance with Executive Order 12612, it is determined that this proposal would not have sufficient federalism implications to warrant the preparation of a Federalism Assessment.

For the reasons discussed above, I certify that this proposed regulation (1) is not a "significant regulatory action" under Executive Order 12866; (2) is not a "significant rule" under the DOT Regulatory Policies and Procedures (44 FR 11034, February 26, 1979); and (3) if promulgated, will not have a significant economic impact, positive or negative, on a substantial number of small entities under the criteria of the Regulatory Flexibility Act. A copy of the draft regulatory evaluation prepared for this action is contained in the Rules Docket. A copy of it may be obtained by contacting the Rules Docket at the location provided under the caption ADDRESSES.

List of Subjects in 14 CFR Part 39

Air transportation, Aircraft, Aviation safety, Safety.

The Proposed Amendment

Accordingly, pursuant to the authority delegated to me by the Administrator, the Federal Aviation Administration proposes to amend part 39 of the Federal Aviation Regulations (14 CFR part 39) as follows:

PART 39—AIRWORTHINESS DIRECTIVES

1. The authority citation for part 39 continues to read as follows:

Authority: 49 U.S.C. 106(g), 40113, 44701.

§ 39.13 [Amended]

2. Section 39.13 is amended by adding the following new airworthiness directive:

British Aerospace Regional Aircraft
[Formerly Jetstream Aircraft Limited, British Aerospace (Commercial Aircraft) Limited]: Docket 97-NM-226-AD.

Applicability: BAe Model ATP airplanes, constructor's numbers 2002 through 2063

inclusive, equipped with brake hydraulic accumulators having APFH part number AIR 87342; certificated in any category.

Note 1: This AD applies to each airplane identified in the preceding applicability provision, regardless of whether it has been modified, altered, or repaired in the area subject to the requirements of this AD. For airplanes that have been modified, altered, or repaired so that the performance of the requirements of this AD is affected, the owner/operator must request approval for an alternative method of compliance in accordance with paragraph (b) of this AD. The request should include an assessment of the effect of the modification, alteration, or repair on the unsafe condition addressed by this AD; and, if the unsafe condition has not been eliminated, the request should include specific proposed actions to address it.

Compliance: Required as indicated, unless accomplished previously.

To detect and correct corrosion of the brake hydraulic accumulators, which could lead to loss of hydraulic pressure and consequent loss of braking capability of the airplane, accomplish the following:

(a) Within 6 months after the effective date of this AD, perform an inspection of the brake hydraulic accumulators for corrosion, in accordance with British Aerospace Service Bulletin ATP-32-80, Revision 1, dated July 9, 1997. If any discrepancy is found, prior to further flight, accomplish corrective actions, as applicable, in accordance with the service bulletin. Repeat the inspection thereafter at intervals not to exceed two years.

(b) An alternative method of compliance or adjustment of the compliance time that provides an acceptable level of safety may be used if approved by the Manager, International Branch, ANM-116, FAA, Transport Airplane Directorate. Operators shall submit their requests through an appropriate FAA Principal Maintenance Inspector, who may add comments and then send it to the Manager, International Branch, ANM-116.

Note 2: Information concerning the existence of approved alternative methods of compliance with this AD, if any, may be obtained from the International Branch, ANM-116.

(c) Special flight permits may be issued in accordance with sections 21.197 and 21.199 of the Federal Aviation Regulations (14 CFR 21.197 and 21.199) to operate the airplane to a location where the requirements of this AD can be accomplished.

Note 3: The subject of this AD is addressed in British airworthiness directive 004-06-97.

Issued in Renton, Washington, on February 3, 1998.

Darrell M. Pederson,
Acting Manager, Transport Airplane Directorate, Aircraft Certification Service.

[FR Doc. 98-3234 Filed 2-9-98; 8:45 am]

BILLING CODE 4010-13-U

DEPARTMENT OF TRANSPORTATION

Federal Aviation Administration

14 CFR Part 39

[Docket No. 97-NM-266-AD]

RIN 2120-AA64

Airworthiness Directives; Aerospatiale Model ATR42-200 and -300 Series Airplanes

AGENCY: Federal Aviation Administration, DOT.

ACTION: Notice of proposed rulemaking (NPRM).

SUMMARY: This document proposes the adoption of a new airworthiness directive (AD) that is applicable to certain Aerospatiale Model ATR42-200 and -300 series airplanes. This proposal would require repetitive inspections for cracking of the lower skin panels of the outer wings; and repair, if necessary. This proposal also would require modification of the panels and a follow-on inspection to detect cracking of the modified areas, which would constitute terminating action for the repetitive inspections. This proposal is prompted by the issuance of mandatory continuing airworthiness information by a foreign civil airworthiness authority. The actions specified by the proposed AD are intended to prevent fatigue cracking of the lower skin panels of the outer wings, and consequent reduced structural integrity of the airplane.

DATES: Comments must be received by March 12, 1998.

ADDRESSES: Submit comments in triplicate to the Federal Aviation Administration (FAA), Transport Airplane Directorate, ANM-114, Attention: Rules Docket No. 97-NM-266-AD, 1601 Lind Avenue, SW., Renton, Washington 98055-4056. Comments may be inspected at this location between 9:00 a.m. and 3:00 p.m., Monday through Friday, except Federal holidays.

The service information referenced in the proposed rule may be obtained from Aerospatiale, 316 Route de Bayonne, 31060 Toulouse, Cedex 03, France. This information may be examined at the FAA, Transport Airplane Directorate, 1601 Lind Avenue, SW., Renton, Washington.

FOR FURTHER INFORMATION CONTACT:

Norman B. Martenson, Manager,
International Branch, ANM-116, FAA,
Transport Airplane Directorate, 1601
Lind Avenue, SW., Renton, Washington
98055-4056; telephone (425) 227-2110;
fax (425) 227-1149.

SUPPLEMENTARY INFORMATION:**Comments Invited**

Interested persons are invited to participate in the making of the proposed rule by submitting such written data, views, or arguments as they may desire. Communications shall identify the Rules Docket number and be submitted in triplicate to the address specified above. All communications received on or before the closing date for comments, specified above, will be considered before taking action on the proposed rule. The proposals contained in this notice may be changed in light of the comments received.

Comments are specifically invited on the overall regulatory, economic, environmental, and energy aspects of the proposed rule. All comments submitted will be available, both before and after the closing date for comments, in the Rules Docket for examination by interested persons. A report summarizing each FAA-public contact concerned with the substance of this proposal will be filed in the Rules Docket.

Commenters wishing the FAA to acknowledge receipt of their comments submitted in response to this notice must submit a self-addressed, stamped postcard on which the following statement is made: "Comments to Docket Number 97-NM-266-AD." The postcard will be date stamped and returned to the commenter.

Availability of NPRMs

Any person may obtain a copy of this NPRM by submitting a request to the FAA, Transport Airplane Directorate, ANM-114, Attention: Rules Docket No. 97-NM-266-AD, 1601 Lind Avenue, SW., Renton, Washington 98055-4056.

Discussion

The Direction Generale de l'Aviation Civile (DGAC), which is the airworthiness authority for France, notified the FAA that an unsafe condition may exist on certain Aerospatiale Model ATR 42-200 and -300 series airplanes. The DGAC advises that full-scale fatigue testing by the manufacturer has revealed damage of the lower skin panels of the outer wings at several rib junction attachments. Such fatigue cracking, if not detected and corrected in a timely

manner, could result in reduced structural integrity of the airplane.

Explanation of Relevant Service Information

Aerospatiale has issued Service Bulletin ATR42-57-0040, dated April 21, 1994, which describes procedures for repetitive ultrasonic inspections for cracking of the lower skin panels of the outer wings at rib 14. Aerospatiale also has issued Service Bulletin ATR42-57-0038, Revision 2, dated December 18, 1997, which describes procedures for modification of the lower skin panels of the outer wings at ribs 13 and 14, and a follow-on high frequency eddy current (HFEC) inspection to detect cracking of the modified area. The modification involves expansion of some holes located between ribs 13 and 18 (left and right sides) to increase resistance of corresponding areas. Accomplishment of the modification and the HFEC inspection would eliminate the need for the repetitive ultrasonic inspections. The DGAC classified these service bulletins as mandatory. Additionally, the DGAC previously issued a French airworthiness directive [93-190-051(B)], dated October 27, 1993) in order to assure the continued airworthiness of these airplanes in France.

FAA's Conclusions

This airplane model is manufactured in France and is type certificated for operation in the United States under the provisions of section 21.29 of the Federal Aviation Regulations (14 CFR 21.29) and the applicable bilateral airworthiness agreement. Pursuant to this bilateral airworthiness agreement, the DGAC has kept the FAA informed of the situation described above. The FAA has examined the findings of the DGAC, reviewed all available information, and determined that AD action is necessary for products of this type design that are certificated for operation in the United States.

Explanation of Requirements of Proposed Rule

Since an unsafe condition has been identified that is likely to exist or develop on other airplanes of the same type design registered in the United States, the proposed AD would require accomplishment of the actions specified in the service bulletin described previously, except as described below.

Differences Between the Proposed AD and the Related Service Information

The proposed AD would differ from Aerospatiale Service Bulletins ATR42-57-0038 and ATR42-57-0040, described previously, in that the service

bulletins recommend that any crack detected during an inspection be repaired in accordance with instructions requested from the manufacturer. However, the FAA has determined that the repair of any crack would be required to be accomplished in accordance with a method approved by the FAA.

Cost Impact

The FAA estimates that 101 airplanes of U.S. registry would be affected by this proposed AD.

It would take approximately 4 work hours per airplane to accomplish the proposed ultrasonic inspection, at an average labor rate of \$60 per work hour. Based on these figures, the cost impact of the ultrasonic inspection proposed by this AD on U.S. operators is estimated to be \$24,240, or \$240 per airplane, per inspection cycle.

It would take approximately 280 work hours per airplane to accomplish the proposed modification, at an average labor rate of \$60 per work hour. The cost of required parts could range from \$1,576 to \$6,373 per airplane. Based on these figures, the cost impact of the modification proposed by this AD on U.S. operators is estimated to be between \$1,855,976 (\$18,376 per airplane) and \$2,340,473 (\$23,173 per airplane).

The cost impact figures discussed above are based on assumptions that no operator has yet accomplished any of the proposed requirements of this AD action, and that no operator would accomplish those actions in the future if this AD were not adopted.

Regulatory Impact

The regulations proposed herein would not have substantial direct effects on the States, on the relationship between the national government and the States, or on the distribution of power and responsibilities among the various levels of government. Therefore, in accordance with Executive Order 12612, it is determined that this proposal would not have sufficient federalism implications to warrant the preparation of a Federalism Assessment.

For the reasons discussed above, I certify that this proposed regulation (1) is not a "significant regulatory action" under Executive Order 12866; (2) is not a "significant rule" under the DOT Regulatory Policies and Procedures (44 FR 11034, February 26, 1979); and (3) if promulgated, will not have a significant economic impact, positive or negative, on a substantial number of small entities under the criteria of the Regulatory Flexibility Act. A copy of the draft regulatory evaluation prepared for this

action is contained in the Rules Docket. A copy of it may be obtained by contacting the Rules Docket at the location provided under the caption ADDRESSES.

List of Subjects in 14 CFR Part 39

Air transportation, Aircraft, Aviation safety, Safety.

The Proposed Amendment

Accordingly, pursuant to the authority delegated to me by the Administrator, the Federal Aviation Administration proposes to amend part 39 of the Federal Aviation Regulations (14 CFR part 39) as follows:

PART 39—AIRWORTHINESS DIRECTIVES

1. The authority citation for part 39 continues to read as follows:

Authority: 49 U.S.C. 106(g), 40113, 44701.

§ 39.13 [Amended]

2. Section 39.13 is amended by adding the following new airworthiness directive:

Aerospatiale: Docket 97-NM-266-AD.

Applicability: Model ATR42-200 and -300 series airplanes on which Aerospatiale Service Bulletins ATR42-57-0040, dated April 21, 1994, and ATR42-57-0038, Revision 2, dated December 18, 1997, have not been accomplished; certificated in any category.

Note 1: This AD applies to each airplane identified in the preceding applicability provision, regardless of whether it has been otherwise modified, altered, or repaired in the area subject to the requirements of this AD. For airplanes that have been modified, altered, or repaired so that the performance of the requirements of this AD is affected, the owner/operator must request approval for an alternative method of compliance in accordance with paragraph (c) of this AD. The request should include an assessment of the effect of the modification, alteration, or repair on the unsafe condition addressed by this AD; and, if the unsafe condition has not been eliminated, the request should include specific proposed actions to address it.

Compliance: Required as indicated, unless accomplished previously.

To prevent fatigue cracking of the lower skin panels of the outer wings between ribs 13 and 18, and consequent reduced structural integrity of the airplane, accomplish the following:

(a) Prior to the accumulation of 25,500 total landings, or within 500 landings after the effective date of this AD, whichever occurs later, perform an ultrasonic inspection for cracking of the lower skin panels of the outer wings, in accordance with Aerospatiale Service Bulletin ATR42-57-0040, dated April 21, 1994. If any crack is detected, prior to further flight, repair it in accordance with a method approved by the Manager, International Branch, ANM-116, FAA, Transport Airplane Directorate. Thereafter,

repeat the inspection at intervals not to exceed 9,000 landings.

(b) Prior to the accumulation of 32,500 total landings, or within 500 landings after the effective date of this AD, whichever occurs later, modify the lower skin panels of the outer wings, and perform a follow-on high frequency eddy current (HFEC) inspection for cracking of the modified areas, in accordance with Aerospatiale Service Bulletin ATR42-57-0038, Revision 2, dated December 18, 1997. If any crack is detected, prior to further flight, repair it in accordance with a method approved by the Manager, International Branch, ANM-116. Accomplishment of the modification and follow-on HFEC inspection constitutes terminating action for the repetitive ultrasonic inspection requirements of paragraph (a) of this AD.

(c) An alternative method of compliance or adjustment of the compliance time that provides an acceptable level of safety may be used if approved by the Manager, International Branch, ANM-116. Operators shall submit their requests through an appropriate FAA Principal Maintenance Inspector, who may add comments and then send it to the Manager, International Branch, ANM-116.

Note 2: Information concerning the existence of approved alternative methods of compliance with this AD, if any, may be obtained from the International Branch, ANM-116.

(d) Special flight permits may be issued in accordance with sections 21.197 and 21.199 of the Federal Aviation Regulations (14 CFR 21.197 and 21.199) to operate the airplane to a location where the requirements of this AD can be accomplished.

Note 3: The subject of this AD is addressed in French airworthiness directive 93-190-051(B), dated October 27, 1993.

Issued in Renton, Washington, on February 3, 1998.

Darrell M. Pederson,

Acting Manager, Transport Airplane Directorate, Aircraft Certification Service.
[FR Doc. 98-3233 Filed 2-9-98; 8:45 am]

BILLING CODE 4910-13-U

DEPARTMENT OF TRANSPORTATION

Federal Aviation Administration

14 CFR Part 39

[Docket No. 97-SW-60-AD]

Airworthiness Directives; Sikorsky Aircraft-Manufactured Model CH-54A Helicopters

AGENCY: Federal Aviation Administration, DOT.

ACTION: Notice of proposed rulemaking (NPRM).

SUMMARY: This document proposes the adoption of a new airworthiness directive (AD) that is applicable to Sikorsky Aircraft-manufactured Model

CH-54A helicopters. This proposal would require an initial and recurring inspections and rework or replacement, if necessary, of the second stage lower planetary plate (plate). This proposal is prompted by cracked plates that have been found during overhaul and inspections. The actions specified by the proposed AD are intended to prevent failure of the plate due to fatigue cracking, which could result in failure of the main gearbox, failure of the drive system, and subsequent loss of control of the helicopter.

DATES: Comments must be received on or before April 13, 1998.

ADDRESSES: Submit comments in triplicate to the Federal Aviation Administration (FAA), Office of Regional Counsel, Southwest Region, Attention: Rules Docket No. 97-SW-60-AD, 2601 Meacham Blvd., Room 663, Fort Worth, Texas 76137. Comments may be inspected at this location between 9:00 a.m. and 3:00 p.m., Monday through Friday, except Federal holidays.

FOR FURTHER INFORMATION CONTACT: Mr. Uday Garadi, Aerospace Engineer, FAA, Rotorcraft Directorate, Rotorcraft Certification Office, Fort Worth, Texas 76193-0170, telephone (817) 222-5157, fax (817) 222-5959.

SUPPLEMENTARY INFORMATION:

Comments Invited

Interested persons are invited to participate in the making of the proposed rule by submitting such written data, views, or arguments as they may desire. Communications should identify the Rules Docket number and be submitted in triplicate to the address specified above. All communications received on or before the closing date for comments, specified above, will be considered before taking action on the proposed rule. The proposals contained in this notice may be changed in light of the comments received.

Comments are specifically invited on the overall regulatory, economic, environmental, and energy aspects of the proposed rule. All comments submitted will be available, both before and after the closing date for comments, in the Rules Docket for examination by interested persons. A report summarizing each FAA-public contact concerned with the substance of this proposal will be filed in the Rules Docket.

Commenters wishing the FAA to acknowledge receipt of their comments submitted in response to this notice must submit a self-addressed, stamped postcard on which the following

statement is made: "Comments to Docket No. 97-SW-60-AD." The postcard will be date stamped and returned to the commenter.

Availability of NPRMs

Any person may obtain a copy of this NPRM by submitting a request to the FAA, Office of Regional Counsel, Southwest Region, Attention: Rules Docket No. 97-SW-60-AD, 2601 Meacham Blvd., Room 663, Fort Worth, Texas 76137.

Discussion

This notice proposes the adoption of a new AD that is applicable to Sikorsky-manufactured Model CH-54A helicopters. This proposal would require an initial and recurring inspections and rework of the plate or replacement, if necessary. It is believed that cracks on the plate initiate at and radiate from the lightning holes in the plate web due to fatigue. This condition, if not corrected, could result in failure of the main gearbox, failure of the drive system, and subsequent loss of control of the helicopter.

Since an unsafe condition has been identified that is likely to exist or develop on other Sikorsky-manufactured Model CH-54A helicopters of the same type design, the proposed AD would require an initial and recurring inspections and replacement, if necessary, of the plate.

The FAA estimates that 9 helicopters of U.S. registry would be affected by this proposed AD, that it would take approximately 8 work hours per helicopter to accomplish the proposed inspections and 56 hours to remove and replace the plate, and that the average labor rate is \$60 per work hour. Required parts would cost approximately \$8,000 per helicopter. Based on these figures, the total cost impact of the proposed AD on U.S. operators is estimated to be \$106,560; \$4,320 to accomplish the inspections and rework, and \$102,240 to replace the plate in the main gearbox assembly in all 9 helicopters, if necessary.

The regulations proposed herein would not have substantial direct effects on the States, on the relationship between the national government and the States, or on the distribution of power and responsibilities among the various levels of government. Therefore, in accordance with Executive Order 12612, it is determined that this proposal would not have sufficient

federalism implications to warrant the preparation of a Federalism Assessment.

For the reasons discussed above, I certify that this proposed regulation (1) is not a "significant regulatory action" under Executive Order 12866; (2) is not a "significant rule" under the DOT Regulatory Policies and Procedures (44 FR 11034, February 26, 1979); and (3) if promulgated, will not have a significant economic impact, positive or negative, on a substantial number of small entities under the criteria of the Regulatory Flexibility Act. A copy of the draft regulatory evaluation prepared for this action is contained in the Rules Docket. A copy of it may be obtained by contacting the Rules Docket at the location provided under the caption ADDRESSES.

List of Subjects in 14 CFR Part 39

Air transportation, Aircraft, Aviation safety, Safety.

The Proposed Amendment

Accordingly, pursuant to the authority delegated to me by the Administrator, the Federal Aviation Administration proposes to amend part 39 of the Federal Aviation Regulations (14 CFR part 39) as follows:

PART 39—AIRWORTHINESS DIRECTIVES

1. The authority citation for part 39 continues to read as follows:

Authority: 49 U.S.C. 106(g), 40113, 44701.

2. Section 39.13 is amended by adding a new airworthiness directive to read as follows:

§ 39.13 [Amended]

Columbia Helicopter; Heavy Lift; Silver Bay Logging; Docket No. 97-SW-60-AD.

Applicability: CH-54A helicopters with lower planetary plate, part number (P/N) 6435-20229-102, installed, certificated in any category.

Note 1: This AD applies to each helicopter identified in the preceding applicability provision, regardless of whether it has been modified, altered, or repaired in the area subject to the requirements of this AD. For helicopters that have been modified, altered, or repaired so that the performance of the requirements of this AD is affected, the owner/operator must use the authority provided in paragraph (d) to request approval from the FAA. This approval may address either no action, if the current configuration eliminates the unsafe condition, or different actions necessary to address the unsafe condition described in this AD. Such a request should include an assessment of the

effect of the changed configuration on the unsafe condition addressed by this AD. In no case does the presence of any modification, alteration, or repair remove any helicopter from the applicability of this AD.

Compliance: Required as indicated, unless accomplished previously.

To prevent failure of the second stage lower planetary plate (plate), P/N 6435-20229-102, due to fatigue cracking, which could lead to failure of the main gearbox, failure of the drive system, and subsequent loss of control of the helicopter, accomplish the following:

(a) On or before accumulating 1,300 hours time-in-service (TIS) conduct a fluorescent magnetic particle inspection of the plate, P/N 6435-20229-102, in the circumferential and longitudinal directions using the wet continuous method. Pay particular attention to the area around the 9 lightning holes.

(1) If any crack is discovered, replace the plate with an airworthy plate.

(2) If no crack is discovered, rework the plate as follows:

(i) Locate the center of each 1.750 inch-diameter lightning hole and machine holes 0.015 to 0.020 oversize on a side (0.030 to 0.040 diameter oversize). Machined surface roughness must not exceed 63 microinches AA rating (see Figure 1).

(ii) Radius each hole 0.030 to 0.050 inches on each edge as shown in Figure 1.

(iii) Mask the top and bottom surfaces of the plate to expose 3.20 inch minimum width circumferential band as shown in Figure 1.

(iv) Vapor blast or bead exposed surfaces to remove protective finish. Use 220 aluminum oxide grit at a pressure of 80 to 90 pounds per square inch.

(v) Shot peen exposed surfaces and inside and edges of lightning holes to 0.008—0.012A intensity. Use cast steel shot, size 170; two hundred percent coverage is required. Use the tracer dye inspection method to ensure the required coverage. Also, visually inspect the shot peened surfaces for correct shot peen coverage. Inspect the intensity of the shot by performing an Almen strip height measurement.

(vi) Clean reworked surfaces using acetone. Touch up the reworked areas using Presto Black or an equivalent touchup solution. Ensure that the touchup solution is at a temperature between 70° F to 120° F during use. Keep the reworked surfaces wet with touchup solution for three minutes to obtain a uniform dark color. Rinse and dry the reworked areas.

(vii) Polish the reworked surfaces with a grade 00 or finer steel wool and polish with a soft cloth. Coat the reworked surfaces with preservative oil.

(viii) Identify the reworked plate by adding "TS-107" after the part number using a low-stress depth-controlled impression-stamp with a full fillet depth of not more than 0.003 inch (see Figure 1).

BILLING CODE 4910-13-U

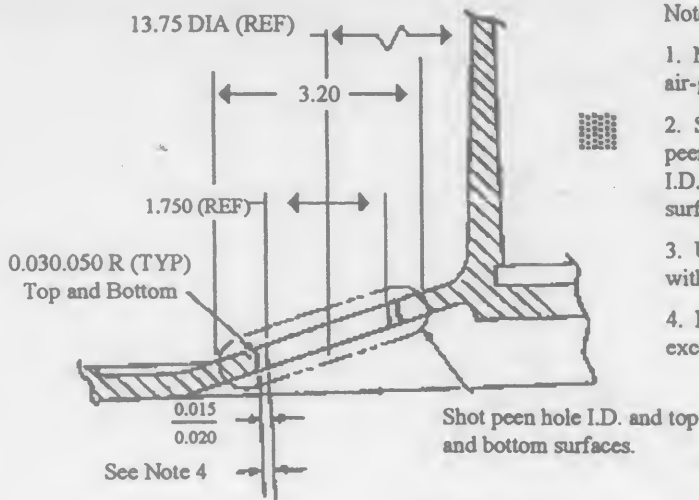

Notes:

1. Mask top and bottom areas to protect from liquid air-grit and shot peen.
2. Shaded area to be liquid air-grit blasted and shot peened includes plate top and bottom surfaces and I.D. of all lightening holes. Feather shot peened surface edges.
3. Use low-stress depth controlled impression-stamp with full fillet depth of no more than 0.003 inch.
4. Reworked machined surface roughness shall not exceed 63 microinches AA rating.

Section B-B
(Typical Nine Places)

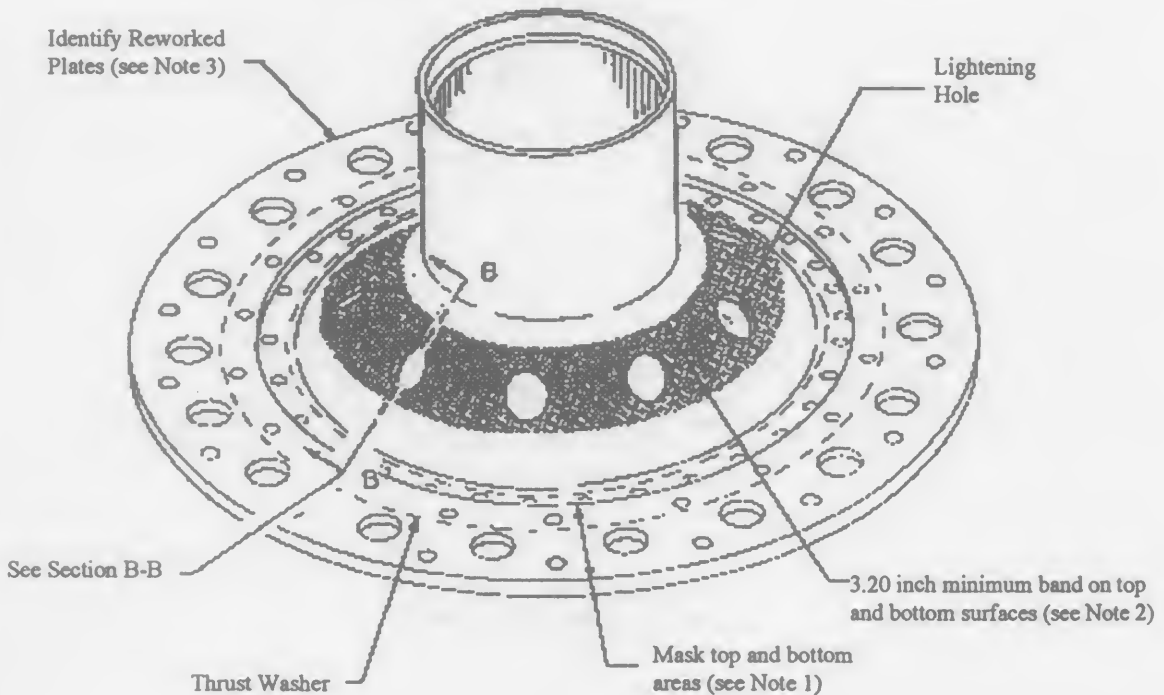

Rework of Second Stage
Lower Planetary Plate (6435-20229-102)
Figure 1

(3) For any plate, P/N 6435-20229-102, that has been reworked and identified with "TS-107," on or before the accumulation of 1,500 hours TIS and thereafter at intervals

not to exceed 70 hours TIS, accomplish the following:

(1) Inspect the plate for a crack in the area around all nine lightening holes using a

Borescope or equivalent inspection method (see Figure 2).

(2) If a crack is found, replace the plate with an airworthy plate.

BILLING CODE 4910-13-U

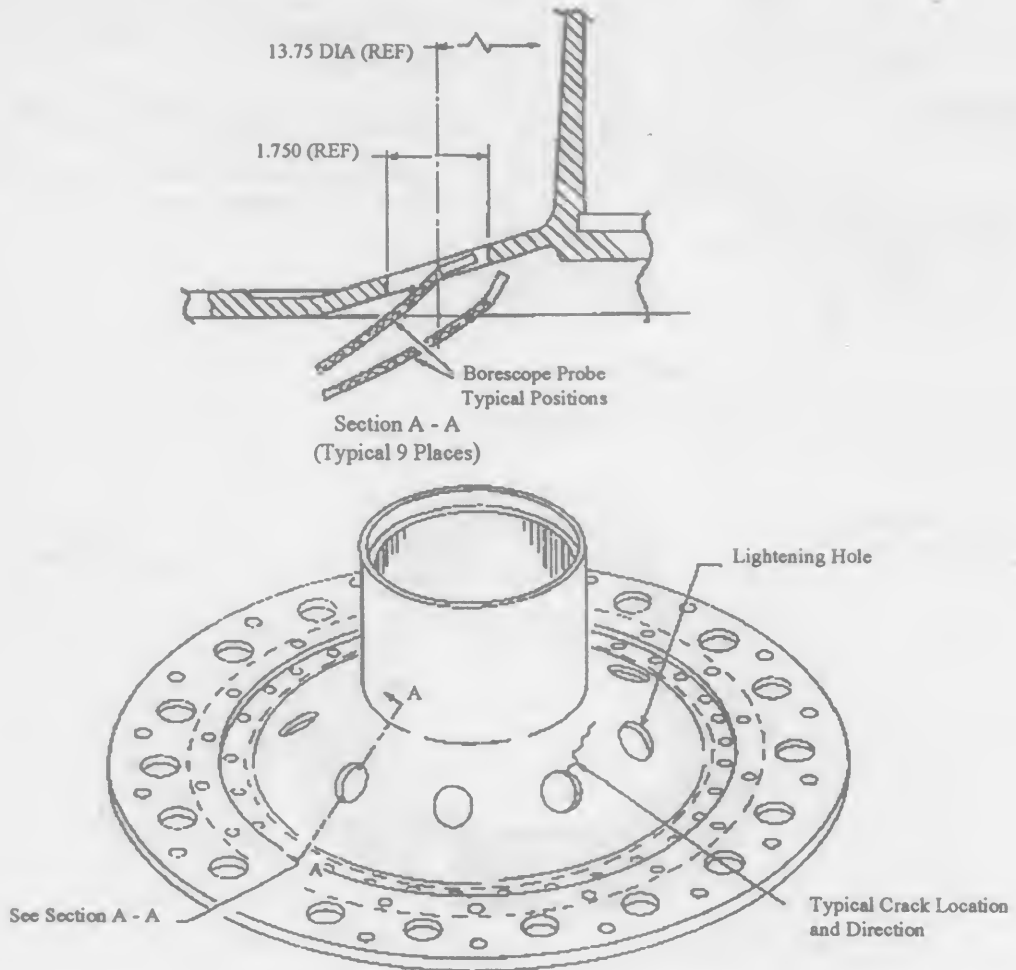

Borescope Inspection of
Second Stage Lower Planetary Plate
Figure 2

(c) On or before the accumulation of 2,600 hours TIS, remove from service plates, P/N 6435-20229-102, reidentified as P/N 6435-20229-102-TS-107 after rework. This AD revises the airworthiness limitation section of the maintenance manual by establishing a retirement life of 2,600 hours TIS for the main gearbox assembly second stage lower planetary plate, P/N 6435-20229-102, reidentified as P/N 6435-20229-102-TS-107 after rework.

Note 2: Erickson Air-Crane Company Service Bulletin No. 64B35-7C, dated November 8, 1995 pertains to the subject of this AD.

(d) An alternative method of compliance or adjustment of the compliance time that provides an acceptable level of safety may be used if approved by the Manager, Rotorcraft Certification Office, FAA, Rotorcraft Directorate. Operators shall submit their requests through an FAA Principal Maintenance Inspector, who may concur or comment and then send it to the Manager, Rotorcraft Certification Office.

Note 3: Information concerning the existence of approved alternative methods of compliance with this AD, if any, may be obtained from the Rotorcraft Certification Office.

(e) Special flight permits may be issued in accordance with sections 21.197 and 21.199 of the Federal Aviation Regulations (14 CFR 21.197 and 21.199) to operate the helicopter to a location where the requirements of this AD can be accomplished.

Issued in Fort Worth, Texas, on February 3, 1998.

Eric Bries,

*Acting Manager, Rotorcraft Directorate,
Aircraft Certification Service.*

[FR Doc. 98-3228 Filed 2-9-98; 8:45 am]

BILLING CODE 4910-13-U

DEPARTMENT OF TRANSPORTATION

Federal Aviation Administration

14 CFR Part 39

[Docket No. 97-CE-91-AD]

RIN 2120-AA64

Airworthiness Directives; EXTRA Flugzeugbau GmbH Models EA-300 and EA-300/S Airplanes

AGENCY: Federal Aviation Administration, DOT.

ACTION: Notice of proposed rulemaking (NPRM).

SUMMARY: This document proposes to adopt a new airworthiness directive (AD) that would apply to EXTRA Flugzeugbau GmbH (EXTRA) Models EA-300 and EA-300/S airplanes. The proposed AD would require inspecting the rudder control cables to assure that correctly swaged Nicopress® type sleeves are installed at each end of the cables, and replacing any cable

assembly where correctly swaged Nicopress® type sleeves are not installed. The proposed AD is the result of mandatory continuing airworthiness information (MCAI) issued by the airworthiness authority for Germany. The actions specified by the proposed AD are intended to prevent a control cable from pulling through an incorrectly swaged sleeve, which could result in loss of rudder control with consequent loss of control of the airplane.

DATES: Comments must be received on or before March 10, 1998.

ADDRESSES: Submit comments in triplicate to the Federal Aviation Administration (FAA), Central Region, Office of the Regional Counsel, Attention: Rules Docket No. 97-CE-91-AD, Room 1558, 601 E. 12th Street, Kansas City, Missouri 64106. Comments may be inspected at this location between 8 a.m. and 4 p.m., Monday through Friday, holidays excepted.

Service information that applies to the proposed AD may be obtained from EXTRA Flugzeugbau GmbH, Flugplatz Dinslaken, D-4224 Hünxe, Germany. This information also may be examined at the Rules Docket at the address above.

FOR FURTHER INFORMATION CONTACT: Mr. Karl Schletzbaum, Aerospace Engineer, FAA, Small Airplane Directorate, 1201 Walnut Street, suite 900, Kansas City, Missouri 64106; telephone: (816) 426-6934; facsimile: (816) 426-2169.

SUPPLEMENTARY INFORMATION:

Comments Invited

Interested persons are invited to participate in the making of the proposed rule by submitting such written data, views, or arguments as they may desire. Communications should identify the Rules Docket number and be submitted in triplicate to the address specified above. All communications received on or before the closing date for comments, specified above, will be considered before taking action on the proposed rule. The proposals contained in this notice may be changed in light of the comments received.

Comments are specifically invited on the overall regulatory, economic, environmental, and energy aspects of the proposed rule. All comments submitted will be available, both before and after the closing date for comments, in the Rules Docket for examination by interested persons. A report that summarizes each FAA-public contact concerned with the substance of this proposal will be filed in the Rules Docket.

Commenters wishing the FAA to acknowledge receipt of their comments submitted in response to this notice must submit a self-addressed, stamped postcard on which the following statement is made: "Comments to Docket No. 97-CE-91-AD." The postcard will be date stamped and returned to the commenter.

Availability of NPRMs

Any person may obtain a copy of this NPRM by submitting a request to the FAA, Central Region, Office of the Regional Counsel, Attention: Rules Docket No. 97-CE-91-AD, Room 1558, 601 E. 12th Street, Kansas City, Missouri 64106.

Discussion

The Luftfahrt-Bundesamt (LBA), which is the airworthiness authority for Germany, notified the FAA that an unsafe condition may exist on EXTRA Models EA-300 and EA-300/S airplanes. The LBA advises of an incident on one of the affected airplanes where loss of rudder control was reported. Preliminary investigation reveals that the rudder control cable pulled through an incorrectly swaged Nicopress® type sleeve.

These conditions, if not detected and corrected, could result in loss of rudder control with consequent loss of control of the airplane.

Relevant Service Information

EXTRA has issued Service Bulletin No. 300-1-93, dated February 9, 1993, which includes measurements and information for inspecting the rudder control cables for correctly swaged Nicopress® type sleeves. Procedures for conducting this inspection are included in Advisory Circular (AC) 43.13-1A, Acceptable Methods, Techniques and Practices.

The LBA classified EXTRA Service Bulletin No. 300-1-93, dated February 9, 1993, as mandatory and issued German AD No. 93-081, dated March 15, 1993, in order to assure the continued airworthiness of these airplanes in Germany.

The FAA's Determination

This airplane model is manufactured in Germany and is type certificated for operation in the United States under the provisions of section 21.29 of the Federal Aviation Regulations (14 CFR 21.29) and the applicable bilateral airworthiness agreement. Pursuant to this bilateral airworthiness agreement, the LBA has kept the FAA informed of the situation described above.

The FAA has examined the findings of the LBA; reviewed all available

information, including the service information referenced above; and determined that AD action is necessary for products of this type design that are certificated for operation in the United States.

Explanation of the Provisions of the Proposed AD

Since an unsafe condition has been identified that is likely to exist or develop in other EXTRA Models EA-300 and EA-300/S airplanes of the same type design registered in the United States, the FAA is proposing AD action. The proposed AD would require inspecting the rudder control cables to assure that correctly swaged Nicopress® type sleeves are installed at each end of the cables, and replacing any cable assembly where correctly swaged Nicopress® type sleeves are not installed. Accomplishment of the proposed inspection would be required in accordance with EXTRA Service Bulletin No. 300-1-93, dated February 9, 1993, and AC 43.13-1A, Acceptable Methods, Techniques and Practices. The proposed replacement would be required in accordance with the maintenance manual.

Cost Impact

The FAA estimates that 23 airplanes in the U.S. registry would be affected by the proposed AD, that it would take approximately 6 workhours per airplane to accomplish the proposed actions, and that the average labor rate is approximately \$60 an hour. Parts cost approximately \$500 per airplane. Based on these figures, the total cost impact of the proposed AD on U.S. operators is estimated to be \$19,780, or \$860 per airplane.

Regulatory Impact

The regulations proposed herein would not have substantial direct effects on the States, on the relationship between the national government and the States, or on the distribution of power and responsibilities among the various levels of government. Therefore, in accordance with Executive Order 12612, it is determined that this proposal would not have sufficient federalism implications to warrant the preparation of a Federalism Assessment.

For the reasons discussed above, I certify that this action (1) is not a "significant regulatory action" under Executive Order 12866; (2) is not a "significant rule" under DOT Regulatory Policies and Procedures (44 FR 11034, February 26, 1979); and (3) if promulgated, will not have a significant economic impact, positive or negative, on a substantial number of small entities

under the criteria of the Regulatory Flexibility Act. A copy of the draft regulatory evaluation prepared for this action has been placed in the Rules Docket. A copy of it may be obtained by contacting the Rules Docket at the location provided under the caption ADDRESSES.

List of Subjects in 14 CFR Part 39

Air transportation, Aircraft, Aviation safety, Safety.

The Proposed Amendment

Accordingly, pursuant to the authority delegated to me by the Administrator, the Federal Aviation Administration proposes to amend part 39 of the Federal Aviation Regulations (14 CFR part 39) as follows:

PART 39—AIRWORTHINESS DIRECTIVES

1. The authority citation for part 39 continues to read as follows:

Authority: 49 U.S.C. 106(g), 40113, 44701.

§ 39.13 [Amended]

2. Section 39.13 is amended by adding a new airworthiness directive (AD) to read as follows:

Extra Flugzeugbau GmbH: Docket No. 97-CE-91-AD.

Applicability: Models EA-300 and EA-300/S airplanes, all serial numbers, certificated in any category.

Note 1: This AD applies to each airplane identified in the preceding applicability provision, regardless of whether it has been modified, altered, or repaired in the area subject to the requirements of this AD. For airplanes that have been modified, altered, or repaired so that the performance of the requirements of this AD is affected, the owner/operator must request approval for an alternative method of compliance in accordance with paragraph (d) of this AD. The request should include an assessment of the effect of the modification, alteration, or repair on the unsafe condition addressed by this AD; and, if the unsafe condition has not been eliminated, the request should include specific proposed actions to address it.

Compliance: Required as indicated in the body of this AD, unless already accomplished.

To prevent a control cable from pulling through an incorrectly swaged sleeve, which could result in loss of rudder control with consequent loss of control of the airplane, accomplish the following:

(a) Within the next 100 hours time-in-service (TIS) after the effective date of this AD, inspect the rudder control cables to assure that correctly swaged Nicopress® type sleeves are installed at each end of the cables. Accomplish this inspection in accordance with EXTRA Service Bulletin No. 300-1-93, dated February 9, 1993, and Advisory Circular (AC) 43.13-1A, Acceptable Methods, Techniques and Practices.

(b) Prior to further flight, replace any cable assembly where correctly swaged Nicopress® type sleeves are not installed with cable assemblies that have correctly swaged Nicopress® type sleeves installed.

(1) Accomplish the replacement in accordance with the maintenance manual.

(2) Accomplish the installation in accordance with EXTRA Service Bulletin No. 300-1-93, dated February 9, 1993, and AC 43.13-1A, Acceptable Methods, Techniques and Practices.

(c) Special flight permits may be issued in accordance with sections 21.197 and 21.199 of the Federal Aviation Regulations (14 CFR 21.197 and 21.199) to operate the airplane to a location where the requirements of this AD can be accomplished.

(d) An alternative method of compliance or adjustment of the compliance time that provides an equivalent level of safety may be approved by the Manager, Small Airplane Directorate, FAA, 1201 Walnut, suite 900, Kansas City, Missouri 64106. The request shall be forwarded through an appropriate FAA Maintenance Inspector, who may add comments and then send it to the Manager, Small Airplane Directorate.

Note 2: Information concerning the existence of approved alternative methods of compliance with this AD, if any, may be obtained from the Small Airplane Directorate.

(e) Questions or technical information related to EXTRA Service Bulletin No. 300-1-93 dated February 9, 1993, should be directed to EXTRA Flugzeugbau GmbH, Flugplatz Dinslaken, D-4224 Hönxne, Germany. This service information may be examined at the FAA, Central Region, Office of the Regional Counsel, Room 1558, 601 E. 12th Street, Kansas City, Missouri 64106.

Note 3: The subject of this AD is addressed in German AD No. 93-081, dated March 15, 1993.

Issued in Kansas City, Missouri on February 2, 1998.

Carolanne L. Cabrini,
Acting Manager, Small Airplane Directorate,
Aircraft Certification Service.

[FR Doc. 98-3227 Filed 2-9-98; 8:45 am]

BILLING CODE 4910-13-U

ENVIRONMENTAL PROTECTION AGENCY

40 CFR Part 52.

[M56-01-7264b; FRL-5963-6]

Approval and Promulgation of Implementation Plan; Michigan

AGENCY: Environmental Protection Agency.

ACTION: Proposed rule.

SUMMARY: The United States Environmental Protection Agency (USEPA) proposes to approve a revision to Michigan's State Implementation Plan (SIP) that was submitted on May

16, 1996, and supplemented on September 23, 1997. The revision included Part 55 of Act 451 of 1994, the Natural Resources and Environmental Protection Act (Part 55). On December 30, 1997, Michigan Department of Environmental Quality (MDEQ) withdrew most of Part 55. In this action, the United States Environmental Protection Agency (USEPA) is proposing to approve sections 324.5524 and 324.5525 which contain control requirements and applicable definitions for fugitive dust sources.

In the final rules section of this **Federal Register**, the USEPA is approving this action as a direct final without prior proposal because USEPA views this as a noncontroversial action and anticipates no adverse comments. If no adverse comments are received in response to that direct final rule, no further activity is contemplated in relation to this proposed rule. If USEPA receives adverse comments, the direct final rule will be withdrawn and all public comments received will be addressed in a subsequent final rule based on this proposed rule. The USEPA will not institute a second comment period on this action. Any parties interested in commenting on this document should do so at this time.

DATES: Comments on this proposed action must be received by March 12, 1998.

ADDRESSES: Written comments should be sent to: Carlton T. Nash, Chief, Regulation Development Section, Air Programs Branch (AR-18)), USEPA, Region 5, 77 West Jackson Boulevard, Chicago, Illinois 60604-3590.

SUPPLEMENTARY INFORMATION: For additional information, see the direct final rule which is located in the Rules section of this **Federal Register**. Copies of the request and the USEPA's analysis are available for inspection at the following address: (Please telephone Kathleen D'Agostino at (312) 886-1767 before visiting the Region 5 office.) USEPA, Region 5, Air and Radiation Division, 77 West Jackson Boulevard, Chicago, Illinois 60604-3590.

Authority: 42 U.S.C. 7401 *et seq.*

Dated: January 12, 1998.

David A. Ullrich,

Acting Regional Administrator, Region V.
[FR Doc. 98-3176 Filed 2-9-98; 8:45 am]

BILLING CODE 6560-50-P

ENVIRONMENTAL PROTECTION AGENCY

40 CFR Part 52

[TX82-1-7336a; FRL-5962-6]

Approval and Promulgation of Implementation Plan, Texas: 15% Rate-of-Progress Plan, 1990 Emission Inventory, Motor Vehicle Emission Budget, and Contingency Plan for the Beaumont/Port Arthur Ozone Nonattainment Area

AGENCY: Environmental Protection Agency (EPA).

ACTION: Proposed rule.

SUMMARY: In this action, EPA proposes to approve revisions to the Texas State Implementation Plan (SIP) for the Beaumont/Port Arthur ozone nonattainment area for the purpose of satisfying the 15% rate-of-progress requirements of the Clean Air Act as amended in 1990, which will aid in ensuring the attainment of the National Ambient Air Quality Standard for ozone. The EPA is also proposing to approve the associated Motor Vehicle Emission Budget for the area.

In addition, EPA proposes to fully approve revisions to the 1990 base year emissions inventory and the contingency plan for this area.

This proposed action also replaces the proposed limited approval/limited disapproval of the Beaumont/Port Arthur 15% Plan and Contingency Plan published on January 29, 1996, 61 FR 2751. The May 22, 1997 (62 FR 27964), limited approval of the Volatile Organic Compound control measures continues in effect.

In the final rules section of this **Federal Register**, EPA is approving the State's SIP revision as a direct final rule without prior proposal because the Agency views this as a noncontroversial amendment and anticipates no adverse comments. A detailed rationale for the approval is set forth in the direct final rule. If no adverse comments are received in response to this proposed rule, no further activity is contemplated in relation to this rule. If EPA receives adverse comments, the direct final rule will be withdrawn, and all public comments received will be addressed in a subsequent final rule based on this proposed rule. The EPA will not institute a second comment period on this action. Any parties interested in commenting on this action should do so at this time.

Please see the direct final rule of this action located elsewhere in today's **Federal Register** for a detailed description of the Beaumont/Port

Arthur 15% Rate of Progress Plan and Contingency Plan.

DATES: Comments on this proposed rule must be postmarked by March 12, 1998. If no adverse comments are received, then the direct final rule is effective on April 13, 1998.

ADDRESSES: Written comments on this action should be addressed to Mr. Thomas H. Diggs, Chief, Air Planning Section (6PD-L), at the EPA Regional Office listed below. Copies of the documents relevant to this proposed rule are available for public inspection during normal business hours at the following locations. Interested persons wanting to examine these documents should make an appointment with the appropriate office at least 24 hours before the visiting day.

Environmental Protection Agency, Region 6, Multimedia Planning and Permitting Division, 1445 Ross Avenue, Suite 700, Dallas, Texas 75202-2733, telephone (214) 665-7214.

Texas Natural Resource Conservation Commission, 12100 Park 35 Circle, Building F, Austin, Texas 78753.

FOR FURTHER INFORMATION CONTACT: Mr. Guy Donaldson of the EPA Region 6 Air Planning Section at the above address, telephone (214) 665-7242.

SUPPLEMENTARY INFORMATION: See the information provided in the direct final action of the same title which is published in the Rules and Regulations section of this **Federal Register**.

List of Subjects in 40 CFR Part 52

Environmental protection, Air pollution control, Carbon monoxide, Hydrocarbons, Incorporation by reference, Intergovernmental relations, Lead, Nitrogen dioxide, Ozone, Particulate matter, Reporting and recordkeeping requirements, Sulfur oxides, Volatile organic compounds.

Authority: 42 U.S.C. 7401 *et seq.*

Dated: January 22, 1998.

Lynda F. Carroll,

Acting Regional Administrator, Region 6.

[FR Doc. 98-3318 Filed 2-9-98; 8:45 am]

BILLING CODE 6560-50-P

ENVIRONMENTAL PROTECTION AGENCY

40 CFR Part 372

[OPPTS-400122; FRL-5760-2]

Emergency Planning and Community Right to Know; Section 313, Toxic Release Inventory Reporting; Notice of Receipt of Petition

AGENCY: Environmental Protection Agency (EPA).

ACTION: Notice of receipt of petition and request for comments.

SUMMARY: This notice announces the receipt of a petition from the Natural Resources Defense Council (NRDC), Defenders of Wildlife, National Audubon Society and the Humane Society of the United States, requesting EPA to initiate rulemaking to add Standard Industrial Classification (SIC) Code 45, Transportation by Air, to the list of facilities required to report releases under section 313 of the Emergency Planning and Community Right-to-Know Act (EPCRA) and section 6607 of the Pollution Prevention Act of 1990 (PPA). The petition was submitted pursuant to section 313(b)(1)(B) of EPCRA and sections 553(e) and 555(e) of the Administrative Procedure Act (APA). Also, as part of this notice, EPA, as requested by the petitioners, is publishing the petition in its entirety. Finally, EPA is seeking comments from interested or potentially affected parties concerning issues associated with adding airports to the list of facilities that must report under section 313 of EPCRA and section 6607 of the PPA, and the motor vehicle exemption under 40 CFR 372.38(c).

DATES: Written comments in response to this request for comments must be received on or before April 13, 1998.

ADDRESSES: Each comment must bear the docket control number "OPPTS-400122." All comments should be sent in triplicate to: OPPT Document Control Officer (7407), Office of Pollution Prevention and Toxics, Environmental Protection Agency, 401 M St., SW., Room G-099, East Tower, Washington, DC 20460.

Comments and data may also be submitted electronically to: oppt.ncic@epamail.epa.gov. Follow the instructions under Unit IV. of this document. No Confidential Business Information (CBI) should be submitted through e-mail.

All comments which contain information claimed as CBI must be clearly marked as such. Three sanitized copies of any comments containing information claimed as CBI must also be submitted and will be placed in the public record for this action. Persons submitting information on any portion of which they believe is entitled to treatment as CBI by EPA must assert a business confidentiality claim in accordance with 40 CFR 2.203(b) for each such portion. This claim must be made at the time that the information is submitted to EPA. If a submitter does not assert a confidentiality claim at the time of submission, EPA will consider this as a waiver of any confidentiality

claim and the information may be made available to the public by EPA without further notice to the submitter.

FOR FURTHER INFORMATION CONTACT: Vicki Anderson at (202) 260-3544, e-mail: anderson.vicki@epamail.epa.gov. for specific information regarding this notice. For further information on EPCRA section 313, contact the Emergency Planning and Community Right-to-Know Hotline, Environmental Protection Agency, Mail Stop 5101, 401 M St., SW., Washington, DC 20460, Toll-free: 1-800-535-0202, in Virginia and Alaska: 703-412-9877 or Toll free TDD: 800-553-7672.

SUPPLEMENTARY INFORMATION:

I. Background

On April 16, 1997, the EPA received a petition from the Natural Resources Defense Council, Defenders of Wildlife, National Audubon Society, and the Humane Society of the United States, requesting EPA to initiate rulemaking to add Standard Industrial Classification (SIC) Code 45, Transportation by Air, to the list of facilities required to report releases under section 313 of the Emergency Planning and Community Right-to-Know Act and section 6607 of the PPA. The petitioners also requested that the petition be printed in the *Federal Register*. The following is the complete text of the petition:

II. The Petition

April 16, 1997
The Honorable Carol Browner
Administrator
United States Environmental Protection
Agency
401 M Street SW
Washington, D.C. 20460

Re: Petition to Add Standard Industrial Classification Code 45, Transportation by Air, to the List of Facilities Required to Report Releases of Chemicals

Dear Administrator Browner:

Pursuant to section 313(b)(1)(B) of the Emergency Planning and Community Right to Know Act (EPCRA) 42 U.S.C. § 11023(b)(1)(B), and sections 553(e) and 555(e) of the Administrative Procedure Act, 5 U.S.C. §§ 553(e), the undersigned groups hereby petition the United States Environmental Protection Agency (EPA) to initiate rulemaking to add Standard Industrial Code (SIC) 45, Transportation by Air, which includes airports, airline terminals, and aircraft maintenance facilities, to the list of facilities required to report releases of toxic chemicals listed on the Toxic Release Inventory (TRI). We also request that EPA immediately publish this petition in the *Federal Register*.

SIC Code 45 facilities are responsible for the release of millions of pounds of toxic chemicals into the environment each year. Nevertheless, EPA eliminated SIC Code 45 from its first industry expansion rulemaking,

despite EPA's own findings that show SIC Code 45 facilities release more toxic chemicals than do most of the facilities currently proposed for reporting.

For over three years, EPA analyses have shown that SIC Code 45 facilities should be required to report TRI chemical releases. SIC Code 45 was a "Primary Candidate" for inclusion in EPA's industry expansion rulemaking based on volume of TRI chemicals released.¹ In fact, SIC Code 45 ranked third among 25 SIC codes considered for inclusion in the rule. While SIC Code 45 facilities use TRI-listed chemicals for a variety of purposes, ethylene glycol is the TRI chemical used in the greatest quantities at these facilities. According to EPA's own estimates, during icing conditions at the 17 busiest airports in the United States, some 58 million pounds of ethylene glycol are released to the environment each year.² Thus, SIC Code 45 facilities clearly warrant listing.

The undersigned (Natural Resources Defense Council, Defenders of Wildlife, National Audubon Society, and the Humane Society of the United States), represent a group of environmental, wildlife, and humane organizations. The Natural Resources Defense Council (NRDC) is an environmental advocacy organization with over 350,000 members and contributors nationwide. Since 1970, NRDC's scientists and attorneys have been key players in virtually every critical environmental issue. Defenders of Wildlife, representing 200,000 members, is one of the leading national organizations fighting to preserve America's endangered species and biological diversity. National Audubon Society, representing 550,000 members works to conserve and restore natural ecosystems, focusing on birds and other wildlife for the benefit of humanity and the earth's biological diversity. The Humane Society of the United States, with 4.4 million members and constituents, is the largest animal protection organization in the United States. Collectively, the undersigned groups represent over 5 million members and constituents.

I. Introduction

The fundamental purposes of EPCRA are to inform citizens of toxic chemical use in their neighborhoods and to encourage industry to reduce toxic chemical use. Since its enactment in 1986, EPCRA has successfully achieved a significant reduction in toxic chemical use. As Administrator, you have noted, "the success of the program comes from the public's and industry's use of this information to motivate and empower initiatives at all levels; from facility teams, to community groups, to trade associations, and state and local government."³ EPA's failure to include SIC Code 45 in its facility expansion rule has achieved the opposite result; recent data demonstrates that ethylene glycol use at SIC Code 45 facilities is increasing. Because ethylene glycol is cheaper than less toxic alternatives, EPA's failure to include SIC Code 45 facilities in the facility expansion rule has eliminated a critical incentive for these facilities to use less toxic chemicals.

In order to fulfill EPCRA's source reduction and public information objectives, EPA must act to carry out its original intention to require SIC Code 45 facilities to

report TRI releases. As demonstrated below, adding SIC Code 45 to the list of industries required to report TRI releases achieves EPCRA's statutory purposes and satisfies EPA's decisional criteria for adding facilities under EPCRA.

II. SIC Code 45 Meets EPA's Criteria for Addition to the List of Facilities Required to Report TRI Releases

Under EPCRA section 313(b)(1)(B), EPA may add industry groups to the list of facilities required to report TRI releases where EPA determines that adding an industry to the list furthers the purposes of EPCRA.⁴ EPA established three criteria or factors for adding facilities under EPCRA section 313(b)(1)(B) in its first facility expansion rulemaking: (1) the "chemical" factor; (2) the "activity" factor; (3) the "information" factor. SIC Code 45 facilities satisfy each of these criteria and therefore should be required to report TRI releases.

A. The Chemical Factor

In addressing whether the chemical factor is met, EPA considers evidence that facilities within an industry group are reasonably anticipated to use one or more EPCRA 313 listed chemicals as part of its routine operations.⁵ There can be little question that substantial amounts of TRI chemicals are present at SIC Code 45 facilities. In its industry profile, EPA determined that toxic chemicals used by SIC Code 45 facilities include ethylene glycol, trichloroethylene, methylene chloride, acetone, chloroform, methyl ethyl ketone, isopropyl alcohol, glycol ethers, toluene, xylene, and other petroleum distillates.⁶

1. Ethylene Glycol is Toxic to Humans and Wildlife

The quantities of ethylene glycol used at SIC Code 45 facilities pose significant risks to humans, companion animals, and wildlife. Requiring airports to report ethylene glycol releases will encourage more extensive use of less toxic alternatives and will therefore reduce human and wildlife exposure to a toxic substance.

The acute oral toxicity of ethylene glycol in humans is well documented. Initially, ethylene glycol causes impairment of the nervous system, followed by cardiopulmonary toxicity and severe metabolic acidosis (i.e., the blood becomes unacceptably acidic). Kidney failure, major neurological disruption, and death can follow.⁷ The lethal dose of ingested ethylene glycol in humans is approximately 1.57g/kg body weight.⁸ For a 155 pound person, this dose is approximately equal to three ounces. In 1994, 4,792 cases of ethylene glycol ingestion were reported to poison control centers throughout the United States.⁹ Of these exposures, 106 cases were life-threatening or resulted in significant residual disability, and 34 cases resulted in death.¹⁰

Chronic effects from ethylene glycol ingestion include reproductive, developmental, and renal effects. Ethylene glycol was found to cause birth defects in mice.¹¹ EPA has recognized the heightened chronic toxicity of ethylene glycol by establishing Reference Doses (RfDs)¹² and long-term Drinking Water Health Advisories. The RfD of ethylene glycol is 2.0 mg/kg/day.¹³ The Drinking Water Health Advisory

for ethylene glycol is 5.5 mg/L for children and 19.25 mg/L for adults.¹⁴ The FDA has stated that drugs containing ethylene glycol are considered dangerous to health and are misbranded¹⁵ and that "under no circumstances [is ethylene glycol] to be used in any product, whether food, drug, or cosmetic that is likely to be taken internally or otherwise absorbed by external application."¹⁶

Ethylene glycol has also been shown to be toxic by inhalation. Inhalation, of course, is the likely exposure pathway for airport users such as passenger and flight crew as well as airport ground crews. Exposure to as little as 3 to 67 mg/m³ of ethylene glycol for a thirty-day period caused throat irritation and headaches in humans.¹⁷ Levels above 140 mg/m³ caused pronounced respiratory irritation, and subjects could not tolerate levels of 200 mg/m³.¹⁸ In animals ethylene glycol has been shown to cause irritation of the eyes and respiratory tract, as well as the intestine and lymph nodes. Further, inhalation of ethylene glycol has been shown to cause birth defects in laboratory experiments.¹⁹

Ethylene glycol is also extremely toxic to animals. Moreover, since it has a sweet taste, it is attractive to both wild animals and companion animals, thus increasing the likelihood of ingestion. A recent study of small practice veterinarians throughout the United States found that more than 90,000 dogs and cats die each year from ingesting ethylene glycol antifreeze.²⁰ Another study estimated that almost 30 percent of all documented dog and cat poisonings were due to ethylene glycol.²¹ Endangered species have also been poisoned. In 1992, a California Condor drank antifreeze and died.²² Migratory birds and large, as well as small animals have succumbed. In 1989, the remains of a polar bear were found on an Alaskan island; ethylene glycol was present in the soil under the carcass. The polar bear apparently ingested an ethylene glycol mixture that was used to mark the centerline of roads and runways covered with snow and ice.²³

2. Health Effects of Other Toxic Substances Used at Many Airports

While ethylene glycol appears to be the most prevalent toxic substance used at airports, maintenance facilities at many airports apply chemicals including trichloroethylene, toluene, methylene chloride, chloroform and glycol ethers, which can have serious human health implications. For example, breathing large amounts of methylene chloride for even short periods adversely affects the human nervous system and the heart, and repeated exposure to methylene chloride causes kidney and liver damage and cancer in laboratory tests—repeat exposure may likewise cause cancer in humans.²⁴ Very high levels of chloroform may result in unconsciousness and death, and in moderate amounts chloroform affected reproduction in animal studies. In addition, the Department of Health and Human Services has determined that chloroform may reasonably be anticipated to be a carcinogen.²⁵ Low-to-moderate levels of toluene from long-term exposure can cause memory loss, nausea, loss of appetite, and

hearing loss. Toluene also affects the kidneys. Repeated exposure to high levels of toluene can cause permanent brain and speech damage, vision and hearing problems, memory loss and decreased mental ability.²⁶

3. Significant Human and Wildlife Exposure Results From Deicing Operations

Release of very large volumes of ethylene glycol during deicing and anti-icing operations create the potential for human exposures that may have significant health consequences for airline passengers, employees, and other service personnel.²⁷ For example, ethylene glycol has been measured during deicing operations at levels up to 18 mg/L in ambient air.²⁸ One study showed that an airline deicing employee could be exposed to 104 mg/m³ of ethylene glycol through a saturated mask,²⁹ which would exceed the concentration of 100 mg/m³ in the current ACGIH TLV if the employee sprayed for eight hours. Ethylene glycol has also been measured inside aircraft during deicing operations at levels close to 2 mg/L.³¹

A recent survey found that 45 of the 50 busiest airports in the United States were located within three miles of an ocean, bay, lake, reservoir, river, wetland or stream.³² Ethylene glycol has the potential to enter drinking water supplies through discharges to surface waters or releases to ground water. Moreover, unless the ethylene glycol fluid is captured for recycling, which does not appear to be a common airport practice in the United States,³³ the fluid may puddle on-site, infiltrate soil, flow into creeks, streams, or rivers, or be retained in on-site retention basins. Wildlife forage in these environs. Migratory birds are particularly attracted to pooled water. SIC Code 45 facilities may be located adjacent to or in the vicinity of wildlife refuges. For example, John F. Kennedy International Airport in New York borders on the Jamaica Bay National Wildlife Refuge—a critical habitat for many species of migratory birds, waterfowl, and wildlife. Denver's airport is near the Rocky Mountain Arsenal National Wildlife Refuge.

Ethylene glycol has been measured in stormwater following deicing operations in concentrations as high as 19,800 mg/L,³⁴ and up to 13,200 mg/L in receiving waters.³⁵ Ethylene glycol in stormwater runoff at Salt Lake City International Airport was measured at 19,000 mg/L.³⁶ Levels of ethylene glycol at Denver's Stapleton Airport ranged from zero to 5,050 mg/L, with some later concentrations exceeding 100,000 mg/L.³⁷ These levels far exceed the EPA's one-day federal drinking water health advisory for ethylene glycol of 18.86 mg/L for children.

Because most ethylene glycol releases at airports occur during cold weather, significant concentrations of ethylene glycol will be present downstream from airports. Glycols do not rapidly biodegrade at low temperatures.³⁸ Since biodegradation of ethylene glycol occurs slowly at low temperatures, ethylene glycol travels farther down river ecosystems or through the soil before any biodegradation occurs. Further, biodegradation of ethylene glycol in ground water proceeds at a slower rate than in surface water because of the limited microbial populations and less available

oxygen in groundwater. Thus, there is a greater potential that humans and wildlife will be exposed to a toxic chemical.

In addition, both ethylene glycol and a less toxic alternative, propylene glycol, exert a strong biochemical oxygen demand (BOD) on receiving waters. This contributes to eutrophication (oxygen depletion), nuisance algal blooms, and fishery impacts.

Ethylene glycol releases are by no means the only threat to surface and groundwater that result from operations at SIC Code 45 facilities. Leaking underground storage tanks and pipes are a significant problem. For example, John F. Kennedy International, Dallas-Fort Worth, Atlanta, Los Angeles International, San Francisco, Cleveland, and Miami airports have all reported leaking underground tanks.³⁹ At John F. Kennedy International there are two underground plumes of aviation fuel beneath the airport, estimated to contain 3-5 million gallons of jet fuel, that resulted from leaking underground pipes.⁴⁰

B. The Activity Factor

Under the activity factor EPA considers evidence that facilities within an industry group manufacture, process, or otherwise use one or more TRI chemicals.⁴¹ EPA has determined that facilities in SIC Code 45 may process or otherwise use TRI chemicals, especially ethylene glycol, when conducting aircraft and ground surface deicing or anti-icing operations and maintaining, repairing, and cleaning aircraft.⁴²

During icing conditions, SIC Code 45 facilities apply ethylene glycol to aircraft using hand-held applicators that contain a volume of fluid in a canister connected to a hose and spray nozzle. In most cases, aircraft deicing is conducted at the terminal gate just prior to take-off. At some facilities, aircraft deicing is conducted away from the gate. Sometimes, if an aircraft is held too long at or away from the gate, more than one application of ethylene glycol will be required. Ethylene glycol use at SIC Code 45 facilities is probably unique among TRI chemical use in that its use requires ethylene glycol to be deliberately sprayed into the environment.

EPA determined that ethylene glycol was the chemical used in the largest quantities by SIC Code 45 facilities. During winter months when icy conditions exist, airports and airlines use deicing and anti-icing fluids to ensure passenger safety. If an airplane is covered with ice or snow, thousands of gallons of deicing solution may be necessary to deice just one aircraft. Salt Lake City Airport has reported using 175 to 600 gallons (1,300 to 4,460 pounds) per aircraft.⁴³ Depending on weather conditions, Detroit Metropolitan Airport reported that deicing may require 1,000 to 3,000 gallons (7,400 to 22,300 pounds) of deicing fluid for a commercial plane the size of a DC-8.⁴⁴ In a "worst-case" situation, as much as 4,000 gallons of a 50-50 mixture of glycol and water has been used at Detroit Metropolitan Airport on a large airplane when it was coated with one-half inch of ice.⁴⁵ Up to 1,000 gallons (7,400 pounds) has often been used to deice a single aircraft under severe weather conditions at Stapleton International Airport in Denver.⁴⁶

Per day and over a full season, airports use ethylene glycol in staggering amounts. Based on information filed with its NPDES permit, Chicago O'Hare International Airport reported that from July 1975 to June 1981, its average annual use of ethylene glycol deicing fluid was 348,500 gallons (almost 2.9 million pounds).⁴⁷ Assuming a 90 day de-icing season (undoubtedly longer than reality), this amounts to an average of over 3,800 gallons (36,000 pounds) per day. Similarly, a study at Baltimore Washington International Airport (BWI) estimated between 250,000 and 280,000 gallons (approximately 1,489,600 pounds) of ethylene glycol are used per year.⁴⁸ EPA reports that the 41st busiest airport in the United States (based on numbers of departures), Standiford Field in Louisville, Kentucky, used an average of 33,000 pounds of ethylene glycol per day in connection with its deicing operations in December 1991 and January and February 1992.⁴⁹ EPA also reports, based on a survey conducted by the Airports Council International (ACI), that annual ethylene glycol use at 35 SIC Code 45 facilities ranged from 1,500 to 4,491,400 gallons undiluted (13,965 to 41,814,934 pounds).⁵⁰

The vast majority of the ethylene glycol used is released directly into the environment as airport and runway runoff. Consistent with these reported volumes of ethylene glycol used for deicing operations, EPA's industry profile for SIC Code 45 estimated that 58 million pounds of ethylene glycol would be released annually during icing conditions at the 17 busiest airports in the United States. If these facilities had been required to report ethylene glycol releases in 1993, ethylene glycol would have ranked approximately 12th out of the 316 TRI chemicals reporting TRI release in 1993—outranking total reported releases of such TRI chemicals as sulfuric acid, manganese compounds, and trichloroethylene.⁵¹ If required to report, SIC Code 45 facilities would have ranked 9th in total volume of releases among 20 industries reporting under TRI.⁵²

Ethylene glycol releases from airports are already required to be reported in Canada and to some State agencies in the U.S. Experience under the Canadian National Pollutant Release Inventory (NPRI) generally confirms U.S. projections. The NPRI indicates that over one-half of the facilities with the largest releases of ethylene glycol were airports or aviation service companies.⁵³ In 1993, ethylene glycol ranked ninth in volume of total releases among all reported chemicals in Canada.⁵⁴ Moreover, of the top 10 facilities reporting ethylene glycol in 1993, six were airports, airbases, or aviation service facilities. Ethylene glycol releases for these facilities alone combined totaled 1,326 tons (2,652,000 pounds).⁵⁵ Similarly, SIC Code 45 facilities in Minnesota and Massachusetts report ethylene glycol use to state agencies.⁵⁶ In Minnesota, four facilities reported ethylene glycol use from 80,000 to 2.2 million pounds in 1993. In Massachusetts, one airline reported using 276,000 pounds or gallons (the report did not specify a unit) of ethylene glycol.⁵⁷

In addition to ethylene glycol releases from aircraft deicing, SIC Code 45 facilities use

ethylene glycol to maintain traction on runways during icy conditions. EPA reported, based on the ACI survey, that 4,000 to 36,000 gallons (37,240 to 335,160 pounds) of ethylene glycol was used by one airport to deice airfield surfaces each year.⁵⁸ At Chicago O'Hare International Airport 6.8 million pounds of a 60 percent ethylene glycol solution was applied to runways during the period July 1975 to June 1981.⁵⁹

Ethylene glycol is also a common base for automotive antifreeze. Airport ground service equipment and rental car parking lots may also release ethylene glycol.

Other airport operations use other toxic chemicals (see footnote 6). As EPA noted, cleaning is an essential process in the maintenance and repair of commercial aircraft.⁶⁰ Cleaning removes contaminants and prepares parts for subsequent inspection, repair, bonding, coating, and testing. Aircraft metals and electronics are the primary focus of cleaning activities. Metal cleaning removes oil, grease, and other contaminants from metal parts, while electronics cleaning removes of flux residues that remain after soldering operations and conducted. In both cases, SIC Code 45 facilities use TRI listed solvents in cleaning operations.

C. The Information Factor

Under the information factor, EPA considers evidence regarding whether requiring a candidate industry group to report is reasonably anticipated to increase the information made available pursuant to EPCRA section 313 or otherwise further the purposes of EPCRA section 313. In making this determination EPA considers evidence related to one or more of the following: whether a significant portion of facilities within the candidate industry group (1) are likely to exceed the 313 reporting thresholds, (2) are likely to be subject to an existing statutory or regulatory exemption, (3) are likely to contain release and waste management data, or (4) whether a significant portion of the facilities within the industry group are expected to file a TRI certification statement.⁶¹

1. Requiring SIC Code 45 Facilities to Report Will Increase the Information Made Available Pursuant to EPCRA section 313

EPA estimates that if SIC Code 45 facilities were required to report TRI releases, 824 facilities would submit 984 reports.⁶² EPA further estimates that 748 of these reports would be submitted based on ethylene glycol use in connection with deicing operations.⁶³ Given EPA estimates that ethylene glycol use may exceed 58 million pounds per year, requiring SIC Code 45 facilities to report ethylene glycol releases unquestionably increases the amount of information made available to the public pursuant to EPCRA section 313.

The public has no other means by which to learn that huge quantities of toxic ethylene glycol are being released in their communities. While section 103(a) of the Comprehensive Environmental Response Compensation and Liability Act (CERCLA), 42 U.S.C. § 9603(a); requires any person in charge of a facility from which CERCLA hazardous substances has been released in a quantity that exceeds its reportable quantity (RQ) within a 24 hour period to immediately

notify the National Response Center, few SIC Code 45 facilities have complied with CERCLA's requirements. For those that do, reports are not easily accessed by the public.

The Air Transport Association (ATA) reported to its members and to the Federal Aviation Administration that CERCLA section 103 reporting was not triggered by ethylene glycol use, because "ethylene glycol is typically discharged via storm sewers to a NPDES permitted outfall."⁶⁴ While it is true that CERCLA section 103(a) reporting contains an exemption for federally permitted releases, the ATA's analysis is nevertheless incorrect. To be exempt from CERCLA release reporting, ethylene glycol must be in stormwater discharged through an outfall and must either (1) comply with the effluent limits prescribed in the permit, or (2) be treated in an on-site treatment system as prescribed in the permit, or (3) be a continuous or anticipated intermittent discharge that is conveyed to a point source as provided in the permit or permit application.⁶⁵ Presently, not all SIC Code 45 facilities have NPDES permits that provide for the management or treatment of ethylene glycol. For those that do, the permit may not yet include effluent limitations for ethylene glycol.⁶⁶

Moreover, EPA's current permitting approach to airports, the industrial storm water NPDES program, is not structured to yield either consistent use and release data, or consistent pollution prevention technology implementation. TRI does not have similar exemptions and is therefore the most complete and accessible source of information for the public on toxic chemical releases. EPA's failure to require SIC Code 45 facilities to report toxic chemical use negates TRI's public informational purpose.

The EPA has stated that TRI reporting not only increases the public's knowledge of pollutants released to the environment, but also improves public understanding of the health and environmental risks of toxic chemicals, allows the public to make informed decisions on where to work and live, enhances the ability of corporate lenders and purchasers to more accurately gauge a facility's potential liability, and assists federal, state, and local authorities in making better decisions on acceptable levels of toxics in communities.⁶⁷ This is particularly important where there exist acceptable alternatives as in the case of ethylene glycol deicing. In light of this public informational purpose, EPA should be more inclusive, rather than less, when considering potential benefits of TRI reporting for particular industrial sectors. Including SIC Code 45 facilities would serve this public purpose by encouraging dissemination of information about releases of toxic substances such as ethylene glycol.

2. Requiring SIC Code 45 Facilities to Report Furthers the Purposes of EPCRA

When it appeared that EPA would require the reporting of ethylene glycol, SIC Code 45 facilities significantly reduced their use of ethylene glycol deicing fluids. Before ethylene glycol was considered for placement on the TRI, it was the leading constituent of deicing fluid. With the TRI listing, however, some product substitution with less toxic

alternatives occurred, although alternative deicing fluids cost somewhat more than ethylene glycol. As President Clinton recently stated, EPCRA is intended to "provide a strong incentive for businesses to find their own ways of preventing pollution."⁶⁸ However this promising trend has been reversed due to the exception of SIC code 45 facilities.⁶⁹

Using available alternatives to ethylene glycol avoids releases of TRI-listed toxic chemical without compromising aviation safety and passenger protection. In addition, because less toxic propylene glycol-based alternatives have a bitter taste; they are not attractive to birds and wildlife. (As noted above, ethylene glycol is sweet tasting and is attractive to birds and wildlife.) It is important to note that all glycols are toxic to aquatic life, as they place a high biochemical oxygen demand (BOD) on receiving waters. Using infra-red heat from aircraft deicing is one promising technique that offers the possibility of eliminating glycol use altogether.⁷⁰ Such less toxic alternatives are "environmentally preferable" to ethylene glycol fluids under criteria set forth in the Pollution Prevention Act of 1990 (the PPA).⁷¹ Encouraging product substitution achieves the important goal of source reduction under both TRI and the PPA.⁷²

By failing to include SIC Code 45 facilities in the proposed rule, EPA has sent the wrong message. The EPA has begun to convey the message to stakeholders that it is no longer concerned about ethylene glycol use at these facilities. Such a message weakens the incentive for SIC Code 45 facilities to voluntarily reduce ethylene glycol use. In order to continue decreasing the amount of ethylene glycol that is released from airport deicing operations, EPA must require airports to report ethylene glycol releases on an annual basis.

3. EPA Misapplied the Motor Vehicle Exemption to Exclude SIC Code 45 Facilities From the Industry Expansion Rulemaking

Based on its third place ranking for volume of toxic chemical releases, SIC Code 45 facilities were retained by EPA as a "Primary Candidate" for inclusion in the proposed rule.⁷³ Yet, without explanation, the Agency removed SIC Code 45 facilities from further consideration, asserting that operations at these facilities fall within the motor vehicle exemption.⁷⁴ There is no basis in the administrative record for EPA's application of the motor vehicle exemption. To the contrary, the record expressly indicates that the motor vehicle exemption should not apply to SIC Code 45 facilities because air transportation is the primary economic function.

By applying the motor vehicle exemption to airport deicing operations, EPA has misconstrued the purpose of the exemption. In order to place some limitations on the definition of "otherwise use" under section 313, EPA developed a list of certain exempt uses of toxic chemicals including the "use of products containing toxic chemicals for the purpose of maintaining motor vehicles operated by the facility."⁷⁵ The motor vehicle exemption is not a statutory exemption under EPCRA.

In the proposed facility expansion rule, EPA explained that "the use of materials

containing listed section 313 chemicals for the purpose of maintaining motor vehicles is believed by EPA to be an incidental chemical use relative to the overall function of facilities currently covered under section 313.⁷⁶ The spraying of vast quantities of deicing fluids on aircraft at airports is neither a maintenance activity nor is it "incidental" to the overall function of airports.

The Air Transportation Association of America (ATAA) in comments submitted to the Agency made clear that "the use of deicing fluids is an integral aspect of ensuring aviation safety and a required component of FAA-approved airline deicing programs prescribed by FAA regulations."⁷⁷ While ATAA argued that the motor exemption should apply to the use of solvents in aircraft maintenance operations, ATAA did not describe deicing operations as part of those maintenance activities.⁷⁸ We, however, urge that all activities as SIC Code 45 facilities be listed. Consistent with ATAA's position, EPA's own economic analysis assumed correctly that the motor vehicle exemption would not apply to facilities at which air transportation is the "primary economic function."⁷⁹ Nevertheless, the Agency eliminated SIC Code 45 facilities from the proposed rule based on the motor vehicle exemption, without any supporting reasoning, either in the rule or in the documents supporting the rule.

IV. Conclusion

The undersigned organizations seek to make EPA aware of the health and ecological risks associated with ethylene glycol use at SIC Code 45 facilities and the need to require these facilities to report their releases under the TRI. By this petition, we request that EPA immediately initiate and promptly conclude rulemaking to require SIC Code 45 facilities report their toxic chemical use under the TRI. We also request that EPA immediately publish this petition in the Federal Register.

Respectfully submitted,

/s/

Peter Lehner
Senior Attorney
Natural Resources Defense Council

/s/

Jennifer Stenzel
Research Associate
Natural Resources Defense Council

/s/

James K. Wyerman
Vice President for Program
Defenders of Wildlife

/s/

John D. Echeverria
General Council
National Audubon Society

/s/

Patricia Forkan
Executive Vice President
Humane Society of the United States

/s/

Leslie Sinclair, DVM
Director of Companion Animal Care
Humane Society of the United States

Footnotes

¹ Environmental Protection Agency, Development of SIC Code Candidates: Screening Document (June 1996).

² Science Applications International Corporation, SIC Code Profile 45 Transportation By Air (1994).

³ EPA, Report to President Clinton, Expansion of Community Right-to-Know Reporting to Include Chemical Use Data: Phase III of the Toxics Release Inventory at 2.

⁴ 61 Fed. Reg. 33588, 33593 (June 27, 1996).

⁵ Id. at 33594.

⁶ Science Applications International Corporation, SIC Code Profile 45: Transportation By Air (1994). See also, EPA, Economic Analysis of the Proposed Rule to Add Certain Industries to EPCRA Section 313 (June 1996) at H-2 (facilities under SIC Code 45 are expected to report dichloromethane, ethylene glycol, methyl ethyl ketone, sulfuric acid, toluene, 1,1,1-trichloroethene, and trichloroethylene).

⁷ Agency for Toxic Substances and Disease Registry, Ethylene/Propylene Glycol: Case Studies in Environmental Medicine, US Department of Health and Human Services, prepared by DeLima Associates, San Rafael, California (Aug. 1992).

⁸ The estimate was derived from the lowest dose of ethylene glycol reported to cause death in humans, which was 100 ml of ethylene glycol. Laug, E.P., H.O. Calvery, H.J. Morris, and G. Woodard (1939), The toxicology of some glycols and derivatives, 21 J. Ind. Hyd. Toxicol. 173. On a body weight basis, ethylene glycol is more toxic in humans than animal species. Andrews, L.S. and R. Snyder (1991), Toxic effects of solvents and vapors, in M.O. Amdur, J. Doull and C.D. Klaasen, eds. Cassarett and Doull's Toxicology: The Basic Science of Poisons 4th ed. Pergamon Press, New York.

⁹ Litovitz, T.L., L. Felberg, et al., 1994 Annual Report of the American Association of Poison Control Centers for Toxic Exposure Surveillance System, reprinted in 13 Am. J. Emerg. Med. 551 (1995).

¹⁰ In 1991, 19 deaths were reported; in 1992, eight deaths were reported, and in 1993, 13 deaths were reported. Litovitz, T.L., L.R. Clark, and R. A. Soloway, 1993 Annual Report of The American Association of Poison Control Centers Toxic Exposure Surveillance System, [sic] reprinted in 12 Am. J. Emerg. Med. 546 (1994); Litovitz, T.L., K.C. Holm, et al., 1992 Annual Report of the American Association of Poison Control Centers Toxic Exposure Surveillance System, reprinted in 11 Am. J. Emerg. Med. 494 (1993); Litovitz, T.L., K.C. Holm, et al., 1991 Annual Report of the American Association of Poison Control Centers Toxic Exposure Surveillance System, reprinted in 10 Am. J. Emerg. Med. 452 (1992).

¹¹ Ethylene Glycol was found to cause birth defects at doses of 1640 mg/kg/day. Lamb, J.C., R.R. Maronpot, D.K. Gulati, V.S. Russell, L. Hommel-Barnes, P.S. Sabharwal, Reproductive and developmental toxicity of ethylene glycol in the mouse, 81 Toxicol. Appl. Pharmacol. 110-112 (1985).

¹² An RfD is an estimate of the maximum lifetime daily dose of a substance that will not cause noncarcinogenic effects over a lifetime of ingestion.

¹³ The RfD is based on an oral feeding study in rats. See Depass, L.R., R. H. Garman, M.D., Woodside, W.E., Giddons, R.R. Maronpot, and C.S. Weil, Chronic toxicity and oncogenicity of ethylene glycol in rats and mice, 7 Fund. Appl. Toxicol. 547 (1986).

¹⁴ Ethylene Glycol Health Advisory, US Environmental Protection Agency, Office of Drinking Water (Mar. 31, 1987).

¹⁵ FDA correspondence with industry, TC-389, Aug. 6, 194, reprinted in Kleinfeld, V.A. and C.W. Dunn, Federal Food Drug and Cosmetic Act Judicial Administrative Record, 1938-1949, Food and Drug Law Institute, Commerce Clearing House, Chicago (1978) (FDA Trade Correspondence were pre-1946, informal opinions of the FDA based on replies to day-to-day inquiries; since 1946, the FDA has published Statements of General Policy or Interpretation in the Federal Register).

¹⁶ FDA Correspondence with industry, TC-402, May 14, 1943, reprinted in Kleinfeld, V.A. and C.W. Dunn, Federal food [sic] Drug and Cosmetic Act Judicial Administrative Record, 1936-1949, Food and Drug Law Institute, Commerce Clearing House Chicago (1978). Ethylene Glycol has limited approval as an indirect food additive. It may only be used as a component of food packaging adhesives. [sic] 21 C.F.R. §175.105 (1995) and in the manufacture of various coatings and components of food contact surfaces. 21 C.F.R. § 175.390, 175.300, 175.320, 175.1200, 177.1630, 177.1680, 177.2420, 176.2105 and 176.300 (1995).

¹⁷ Wills, J.H., E.S. Coulston, E.S. Harris, E.W. McChesney, J.C. Russell, and D.M. Serronne, Inhalation of aerosolized ethylene glycol in man, 7 Clin. Toxicol. 463 (1974).

¹⁸ Id.

¹⁹ Tyl, R.W., B. Ballantyne, et al., Evaluation of the developmental toxicity of ethylene glycol aerosol in CD-1 mice by nose-only exposure. 27 Fund. Appl. Toxicol. 49 (1995).

²⁰ American Society for the Prevention of Cruelty to Animals and Safe Brands (1996). LD₅₀ values for ethylene glycol range from 4.0 to 15.4 g/kg for rats, mice, and guinea pigs. Bornmann, G., Grundwirkungen der Glykole und ihre Bedeutung für die Toxizität, 4 Arzenimittelforschung 643 (1954) (mice); Clark, C.R., et al. Toxicological assessment of heat transfer fluids proposed for use in solar energy applications, 51 Toxicol. Appl. Pharmacol. 529 (1979) (rats); Smyth, H.F., Jr., et al., The single dose toxicity of some glycols and derivatives, 23 J. Ind. Hyg. Toxicol. 259 (1941) (guinea pigs).

²¹ Rowland, J., Incidence of ethylene glycol intoxication in dogs and cats seen at Colorado State University Veterinary Teaching Hospital, 29 Vet. Hum Toxicol. 41 (1987). The minimum lethal dose reported for ethylene glycol in rats is 3.8 g/kg and 7.3 g/kg in dogs. Clark, Marshal et al., supra note 35 (rats); Sanyer, J.L. et al. Systematic treatment of ethylene glycol toxicosis in dogs, 34 J. Amer. Vet. Med. Assoc., 527 (1973), as cited in National Toxicology Program, NTP Technical Report on the Toxicology and Carcinogenesis Studies of Ethylene Glycol (CAS No. 107-21) in B6C3F1 Mice (Feed Studies) NIH Publication No. 93-3144, US Department of Health and Human Services (Feb. 1993).

²² U.S. Fish and Wildlife Service, 17 Endangered Species Technical Bulletin 2 (1992). See also, U.S. Fish and Wildlife Services, Fact Sheet: California Condor, (Gymnogyps Californianus) (undated).

²³ S. Anstrup, C. Gardner, K. Myers, F. Oehme, Ethylene Glycol (Antifreeze) Poisoning in a Free-Ranging Polar Bear, 31 Vet. Hum. Toxicol. 317 (1989).

²⁴ U.S. Environmental Protection Agency, Office of Pollution Prevention and Toxics, Chemicals in the Environment: Methylene Chloride (Dichloromethane) (CAS No. 75-09-2) (1994).

²⁵ U. S. Department of Health and Human Services, Agency for Toxic Substances and Disease Registry, Fact Sheet on Chloroform (1993).

²⁶ U.S. Department of Health and Human Services, Agency for Toxic Substances and Disease Registry, Fact Sheet on Toluene (1995).

²⁷ In 1995, a pilot of a commuter flight was doused with deicer fluid while boarding the aircraft at Philadelphia International Airport. The Philadelphia Inquirer (December 21, 1995).

²⁸ Council of Environmentally Sound Deicing, Ethylene Glycol: The Scientific Basis for its Retention on EPA's Toxics Release Inventory (Feb. 1996).

²⁹ Montgomery, J.F., A Discussion of the Toxicological and Biological Effects of Deicing Fluids, American Airlines Environmental Department, at 15 (Sept. 28, 1994).

³⁰ American Conference of Governmental Industrial Hygienists, 1995-1996 Threshold Limit Values for Chemical Substances and Physical Agents and Biological Exposure Indices (BEIs), Cincinnati, Ohio at 21 (1995).

³¹ Council for Environmentally Sound Deicing, Ethylene Glycol: The Scientific Basis for its Retention on EPA's Toxics Release Inventory (Feb. 1996).

³² Natural Resources Defense Council, Flying Off Course (1996) at 56.

³³ Id. at 69.

³⁴ MacDonald, D.D., I.D. Cuthbert, and P.M. Outridge, Canadian Environmental Quality guidelines for Three Glycols Used in Aircraft Deicing/Anti-icing Fluids: Ethylene Glycol; Diethylene Glycol; and Propylene Glycol, EcoHealth Branch, Environment Canada, Ottawa, Ontario, Canada, at 15, 76 (Table 10) (Sept. 1992).

³⁵ Ethylene Glycol levels, based on indirect measurements, reached peak concentrations as high as 59,360 mg/L. Id. at 15, 78 (Table 12).

³⁶ Sills, R.D., and P.A. Blakeslee, Environmental Impact of Deicers in Airport Stormwater Runoff at 324 in F.M. D'Irti, ed., Chemical Deicers in the Environment, Lewis Publishers, Boca Raton, Fla. (1992).

³⁷ U.S. EPA, Office of Water, Permits Division, Contractor Report — Guidance for Issuing NPDES Storm Water Permits for Airports, at 2-8 (Sept. 28, 1990).

³⁸ Klecka, G.M., C.L. Carpenter, B.D. Landenberger, Biodegradation of aircraft deicing fluids in soil at low temperatures, 25 Ecotoxicol. Environ. Safety 280-285 (1993).

³⁹ NRDC, Flying Off Course (1996) at 57.

⁴⁰ Id.

⁴¹ 61 Fed. Reg. at 33594

⁴² EPA, Economic Analysis of the Proposed Rule to Add Certain Industries to EPCRA Section 313 (June 1996) at H-1.

⁴³ ERC Environmental and Energy Services Co., EPA Contractor Report Guidance for Issuing NPDES Storm Water Permits for Airports (1990) at 2-4.

⁴⁴ Id. At 2-5.

⁴⁵ Id.

⁴⁶ Id.

⁴⁷ Id.

⁴⁸ Science Applications International Corporation, SIC Code Profile 45: Transportation by Air (1994) at 7.

⁴⁹ EPA, Office of Prevention, Pesticides and Toxic Substances, Expanded Exposure Assessment for Ethylene Glycol In Response to Delisting Petition (June 16, 1995).

⁵⁰ EPA, Economic Analysis of the Proposed Rule to Add Certain Industries to EPCRA Section 313 (June 1996) at H-4.

⁵¹ EPA, 1993 Toxics Release Inventory: Public Data Release (1995) Document No. 745-R-95-010.

⁵² Id.

⁵³ Twenty-seven airports reported ethylene glycol releases in 1993 with ethylene glycol releases totaling 2166.7 tons (4,333,400 pounds). This constituted 57 percent of all reported ethylene glycol release.

Environment Canada Summary Report of the 1993 National Pollutant Release Inventory at 28-29 (undated).

⁵⁴ Id. At 11.

⁵⁵ Id.

⁵⁶ EPA, Economic Analysis of the Proposed Rule to Add Certain Industries to EPCRA Section 313 (June 1996) at H-13.

⁵⁷ Id. If the unit reported was gallons, ethylene glycol releases exceeded 2.3 million pounds.

⁵⁸ EPA, Economic Analysis of the Proposed Rule to Add Certain Industries to EPCRA Section 313 (June 1996) at H-5.

⁵⁹ ERC Environmental and Energy Services Co., EPA Contractor Report Guidance for Issuing NPDES Storm Water Permits for Airports (1990) at 2-6.

⁶⁰ Science Applications International Corporation, SIC Code Profile 45: Transportation By Air (1994) at 14.

⁶¹ 61 Fed. Reg. at 33594.

⁶² EPA, Economic Analysis of the Proposed Rule to Add Certain Industries to EPCRA Section 313 (June 1996) at H-18.

⁶³ Id.

⁶⁴ ATA, Summary Report to the Federal Aviation Administration Regarding Environmental Issues Associated with Aircraft Deicing and the Use of Glycol-Based Fluids (undated).

⁶⁵ R. Van Voorhees and Green, C. EPA Clarifies Reporting Requirements for Ethylene Glycol Releases from Airport Deicing Operations, BNA, Analysis Perspective (August 30, 1996).

⁶⁶ See *Buchholz v. Dayton International Airport et al.*, (Magistrates Report and Recommendation), Case No. C-3-94-435 (S.D. Ohio, June 26, 1995) (citizen suit filed under the CWA and RCRA against the airport by residents who use a creek receiving airport deicing flows for drinking, bathing, washing clothes, and dishes).

⁶⁷ 60 Fed. Reg. 59664 (Nov. 28 1995).

⁶⁸ Report to President Clinton, Expansion of Community Right-to-Know Reporting to

Include Chemical Use Data: Phase III of the Toxics Release Inventory (EPA Report to the President) at 2 (undated).

⁶⁹ The trend away from ethylene glycol use, however, was superseded by an FAA safety rule in the early 1990's that effectively mandated a doubling in the volume of de-icing products applied at airports; thus we are still seeing the massive quantities of ethylene glycol in use that was documented earlier in this petition.

⁷⁰ NRDC, *Flying Off Course* (1996) at 63.

⁷¹ 42 U.S.C. §§13101-09 (West 1995).

⁷² Section 6603(5)(A) defines "source reduction" as any practice that reduces the amount of any hazard from any hazardous substance, pollutant, or contaminant entering any waste stream or otherwise released into the environment, including substitution of raw materials. 42 U.S.C. § 113102(5)(A).

⁷³ EPA Development of SIC Code Candidates: Screening Document (June 1996) at 13.

⁷⁴ Id. at 17.

⁷⁵ 53 Fed. Reg. 4506 (Feb. 16, 1988).

⁷⁶ 61 Fed. Reg. 33596 (emphasis added).

⁷⁷ ATAA Comments on EPA's

Consideration of Airports for Inclusion in the TRI Program, May 25, 1995 (Docket #400104, D3-0010) at 4.

⁷⁸ See Id. at 11-12. 79 EPA, Economic Analysis of the Proposed Rule to Add Certain Industries to EPCRA Section 313 (June 1996) at H-1.

III. Issues

There are two issues that could potentially affect reporting by airports: (1) Whether airports would be exempt from reporting the majority of their toxic chemical releases because of the motor vehicle exemption, and (2) whether airports fit within the definition of facility under 40 CFR 372.1. In addition, there are issues relating to the application of the motor vehicle exemption as it pertains to motor vehicles used in industries recently added to the list of facilities subject to EPCRA section 313 reporting requirements. In light of these concerns, EPA is considering a modification in the motor vehicle exemption. The Agency is interested in receiving comments regarding these issues and other matters relevant to the petition and its response from potentially affected or interested parties. The comments will help EPA better understand relevant issues surrounding the addition of airports to the list of facilities required to report pursuant to section 313 of EPCRA, and the motor vehicle exemption in general.

A. Motor Vehicle Exemption

EPA is seeking comments from potentially affected and interested parties concerning whether the use of ethylene glycol and other EPCRA section 313 chemicals at airports would or should be exempt under the Motor

Vehicle Maintenance Exemption, 40 CFR 372.38(c).

In the February 16, 1988 Final Rule implementing the reporting requirements of EPCRA section 313 (53 FR 4500), EPA limited the definition of "otherwise use" by exempting certain uses of toxic chemicals. Section 372.38(c) states that if a toxic chemical is used at a covered facility for a purpose described in paragraph (c), a person is not required to consider the quantity of the toxic chemical used for such purpose when determining whether an applicable threshold has been met under § 372.25 or when determining the amount of releases to be reported under § 372.30. 40 CFR 372.38(c)(4) further states that "use of products containing toxic chemicals for the purpose of maintaining motor vehicles operated by the facility" are exempted from reporting under 40 CFR 372.30.

In previous guidance, EPA has stated that airplanes are motor vehicles and that this exemption applies to fuels and other products containing toxic chemicals for the purpose of maintaining motor vehicles (see Toxic Chemical Release Inventory Reporting Package for 1990, January 1991, EPA 560/4-91-001, p. A-5). In keeping with this guidance, toxic chemicals found in gasoline, diesel fuel, brake and transmission fluids, oils and lubricants, antifreeze, batteries, cleaning solutions, and solvents in paints may be excluded from reporting under § 372.30 as long as a facility uses these products to maintain its motor vehicles. While motor vehicle maintenance may be an incidental activity at the facilities originally subject to EPCRA section 313 reporting requirements (i.e., the manufacturing sector), EPA believes that this is not the case at airports, where the maintenance of vehicles is integral to the activities at the airport. For example, use of ethylene glycol to de-ice planes and runways is essential for the operation of airplanes when icy conditions and inclement weather may hinder their safe operation. In such cases, the use of ethylene glycol is in no way "incidental" to the operation of airports. In addition, EPA believes that maintaining motor vehicles is integral to activities that occur at some of the industry groups recently added to the list of facilities subject to reporting under EPCRA section 313 and PPA section 6607 (see 62 FR 23834, May 1, 1997). For example, use of earth moving equipment is an integral part of the mining industry and use of tanker trucks is an integral part of the operation of bulk petroleum stations.

EPA, therefore, requests comments on a number of options to modify or eliminate the motor vehicle exemption at 40 CFR 372.38(c)(4). These options include:

1. Making no change to the motor vehicle exemption.

2. Not allowing certain industries, such as the transportation industry, in which motor vehicle use is the industry's main activity, to take the motor vehicle exemption. The motor vehicle exemption would continue to apply to other covered industries.

3. For covered industries, narrowing the motor vehicle exemption so that it would only apply to incidental motor vehicle use. It would not apply to any activity that is process-related. For example: the motor vehicle exemption would not apply to toxic chemicals used in jet fuel while a jet is at an airport, deicing, and other vehicle maintenance activities. As a second example, for covered industries such as metal mining and bulk petroleum stations, the motor vehicle exemption would no longer apply to vehicles used in processing activities (e.g., earth-moving equipment or trucks and transport vehicles at petroleum facilities which are maintained on-site), or

4. Eliminating the motor vehicle exemption entirely.

B. Definition of Facility under EPCRA

1. *Definition of facility.* Under EPCRA section 329(4) and 40 CFR 372.1, a "facility" means all buildings, equipment, structures and other stationery items which are located on a single site or on contiguous or adjacent sites and which are owned or operated by the same person (or by any person which controls, is controlled by, or under common control with such person). A facility may contain more than one establishment.

2. *Application of definition of facility to airports.* Airports typically operate under a single management organization known as the airport "authority" which, in most cases is a public agency. Airline carriers that have contracts with the airport authority to conduct business on airport property are commonly known as "tenants" of the airport. In order to comply with various state and Federal environmental regulations, an airline may require (as part of a lease agreement) a tenant to report its aggregate releases of toxic or hazardous chemicals directly to the owners or operators of the airport authority.

On the other hand, the Agency recognizes that if airports were required to report under section 313 of EPCRA and section 6607 of the PPA, there could be unique reporting issues

associated with their ownership, operation, and control. Therefore, the Agency is interested in receiving comments or information concerning how airports operate and the practical impacts of requiring airports to report under section 313 of EPCRA and section 6607 of the PPA. Information gathered from commenters will be used by the agency to determine whether airports fall within the definition of facility.

IV. Public Record and Electronic Submissions

The official record for this document, as well as the public version, has been established for this rulemaking under docket control number "OPPTS-400122" (including comments and data submitted electronically as described below). A public version of this record, including printed, paper versions of electronic comments, which does not include any information claimed as CBI, is available for inspection from 12 noon to 4 p.m., Monday through Friday, excluding legal holidays. The official record is located in the TSCA Nonconfidential Information Center, Rm. NE-B607, 401 M St., SW., Washington, DC.

Electronic comments can be sent directly to EPA at:
oppt.ncic@epamail.epa.gov

Electronic comments must be submitted as an ASCII file avoiding the use of special characters and any form of encryption. Comments and data will also be accepted on disks in WordPerfect 5.1/6.1 or ASCII file format. All comments and data in electronic form must be identified by the docket control number "OPPTS-400122." Electronic comments on this document may be filed online at many Federal Depository Libraries.

List of Subjects in 40 CFR Part 372

Environmental protection, Community right-to-know, Reporting and recordkeeping requirements, and Toxic substances.

Dated: January 29, 1998.

Lynn R. Goldman,
Assistant Administrator for Prevention,
Pesticides and Toxic Substances.

[FR Doc. 98-3316 Filed 2-9-98; 8:45 am]

BILLING CODE 6560-50-F

FEDERAL COMMUNICATIONS COMMISSION

47 CFR Part 73

[MM Docket No. 98-8, RM-9178]

Radio Broadcasting Services; Albion, Honeoye Falls, South Bristol Township, NY

AGENCY: Federal Communications Commission.

ACTION: Proposed rule.

SUMMARY: The Commission requests comments on a petition filed by Citicasters Co. requesting the reallocation of Channel 297A from Honeoye Falls, NY, to South Bristol Township, NY, the modification of Station WRCD's license to specify South Bristol Township as its community of license; the reallocation of Channel 236B from South Bristol Township to Honeoye Falls, NY, the modification of Station WNVE's license to specify Honeoye Falls as its community of license; and the substitution of Channel 271A for Channel 238A at Albion, NY. Channel 236B can be allotted to Honeoye Falls in compliance with the Commission's minimum distance separation requirements, with respect to domestic allotments, with a site restriction of 16.5 kilometers (10.3 miles) northeast, to accommodate petitioner's desired transmitter site. This site is short-spaced to Stations CKQT-FM, Channel 235B, Oshawa, Ontario, and CKDS-FM, Channel 237C1, Hamilton, Ontario, Canada. Channel 297A can be allotted to South Bristol Township in compliance with the Commission's minimum distance separation requirements with a site restriction of 2.9 kilometers (1.8 miles) northwest, to accommodate petitioner's desired transmitter site. Channel 271A can be allotted to Albion in compliance with the Commission's minimum distance separation requirements, with respect to domestic allotments, without the imposition of a site restriction. This allotment would be short-spaced to Station CFNY-FM, Channel 271C1, Brampton, Ontario, Canada, and to the vacant Channel 272B at Belleville, Ontario, Canada. Honeoye Falls, South Bristol Township and Albion are all located within 320 kilometers (200 miles) of the U.S.-Canadian border. Therefore, concurrence by the Canadian Government in the allotments is required. Concurrence by the Canadian Government in the Honeoye Falls and Albion allotments will be requested as specially negotiated short-spaced allotments. The coordinates for Channel 236B at Honeoye Falls are 43-02-00;

77-25-17. The coordinates for Channel 297A at South Bristol Township are 42-44-47; 77-25-35. The coordinates for Channel 271A at Albion are 43-14-48; 78-11-36.

DATES: Comments must be filed on or before March 23, 1998, and reply comments on or before April 7, 1998.

ADDRESSES: Federal Communications Commission, Washington, DC 20554. In addition to filing comments with the FCC, interested parties should serve the petitioner, or its counsel or consultant, as follows: Marissa G. Repp, Hogan & Hartson L.L.P., 555 Thirteenth Street, N.W., Washington, D.C. 20004-1109 (Counsel to petitioner).

FOR FURTHER INFORMATION CONTACT: Leslie K. Shapiro, Mass Media Bureau, (202) 418-2180.

SUPPLEMENTARY INFORMATION: This is a synopsis of the Commission's Notice of Proposed Rule Making, MM Docket No. 98-8, adopted January 21, 1998, and released January 30, 1998. The full text of this Commission decision is available for inspection and copying during normal business hours in the FCC Reference Center (Room 239), 1919 M Street, NW., Washington, DC. The complete text of this decision may also be purchased from the Commission's copy contractor, International Transcription Services, Inc., (202) 857-3800, 1231 20th Street, NW., Washington, DC 20036.

Provisions of the Regulatory Flexibility Act of 1980 do not apply to this proceeding.

Members of the public should note that from the time a Notice of Proposed Rule Making is issued until the matter is no longer subject to Commission consideration or court review, all *ex parte* contacts are prohibited in Commission proceedings, such as this one, which involve channel allotments. See 47 CFR 1.1204(b) for rules governing permissible *ex parte* contacts.

For information regarding proper filing procedures for comments, see 47 CFR 1.415 and 1.420.

List of Subjects in 47 CFR Part 73

Radio broadcasting.

Federal Communications Commission.

John A. Karousos,
Chief, Allocations Branch, Policy and Rules Division, Mass Media Bureau.

[FR Doc. 98-3220 Filed 2-9-98; 8:45 am]

BILLING CODE 6712-01-P

FEDERAL COMMUNICATIONS COMMISSION

47 CFR Part 73

[MM Docket No. 98-9, RM-9216]

Radio Broadcasting Services; Pleasanton, KS

AGENCY: Federal Communications Commission.

ACTION: Proposed rule.

SUMMARY: The Commission requests comments on a petition by the City of Pleasanton, Kansas, requesting the allotment of Channel 268C3 to Pleasanton as the community's first local aural transmission service. Channel 268C3 can be allotted to Pleasanton in compliance with the Commission's minimum distance separation requirements without the imposition of a site restriction. The coordinates for Channel 268C3 at Pleasanton are 38-10-30 NL and 94-42-42 WL.

DATES: Comments must be filed on or before March 23, 1998, and reply comments on or before April 7, 1998.

ADDRESSES: Federal Communications Commission, Washington, DC 20554. In addition to filing comments with the FCC, interested parties should serve the petitioner, or its counsel or consultant, as follows: John S. Sutherland, 522 Main Street, P.O. Box 117, Mound City, Kansas 66056 (Counsel for petitioner).

FOR FURTHER INFORMATION CONTACT: Pam Blumenthal, Mass Media Bureau, (202) 418-2180.

SUPPLEMENTARY INFORMATION: This is a synopsis of the Commission's Notice of Proposed Rule Making, MM Docket No. 98-9, adopted January 21, 1998, and released January 30, 1998. The full text of this Commission decision is available for inspection and copying during normal business hours in the FCC's Reference Center (Room 239), 1919 M Street, NW., Washington, DC. The complete text of this decision may also be purchased from the Commission's copy contractor, ITS, Inc., (202) 857-3800, 1231 20th Street, NW., Washington, DC 20036.

Provisions of the Regulatory Flexibility Act of 1980 do not apply to this proceeding.

Members of the public should note that from the time a Notice of Proposed Rule Making is issued until the matter is no longer subject to Commission consideration or court review, all *ex parte* contacts are prohibited in Commission proceedings, such as this one, which involve channel allotments. See 47 CFR 1.1204(b) for rules governing permissible *ex parte* contacts.

For information regarding proper filing procedures for comments, see 47 CFR 1.415 and 1.420.

List of Subjects in 47 CFR Part 73

Radio broadcasting.

Federal Communications Commission.

John A. Karousos,
Chief, Allocations Branch, Policy and Rules Division, Mass Media Bureau.

[FR Doc. 98-3219 Filed 2-9-98; 8:45 am]

BILLING CODE 6712-01-P

DEPARTMENT OF COMMERCE

National Oceanic and Atmospheric Administration

50 CFR Part 648

[I.D. 012898B]

Fisheries of the Northeastern United States; Northeast Multispecies Fishery; Reopening of Scoping Process for Hake

AGENCY: National Marine Fisheries Service (NMFS), National Oceanic and Atmospheric Administration (NOAA), Commerce.

ACTION: Notice of intent to prepare a supplemental environmental impact statement (SEIS) and notice of reopening the scoping process for silver hake, offshore hake, and red hake; request for comments.

SUMMARY: The New England Fishery Management Council (Council) announces its intent to prepare an amendment to the Northeast Multispecies Fishery Management Plan (FMP) to conserve silver hake (whiting, *Merluccius bilinearis*), offshore hake (*Merluccius albidus*), and red hake (*Urophycis chuss*) stocks, and to prepare an SEIS to analyze the impacts of any proposed management measures. The Council also formally announces the reinitiation of a public process to determine the scope of issues to be addressed in the environmental impact analysis. The purpose of this notice is to alert the interested public of the reopening of the scoping process and to provide for public participation in compliance with environmental documentation requirements.

DATES: Written comments on the scope of the SEIS may be submitted until March 17, 1998. See **SUPPLEMENTARY INFORMATION** for specific dates and times of scheduled scoping meetings.

ADDRESSES: Written comments and requests for copies of the scoping document should be sent to Paul J. Howard, Executive Director, New

England Fishery Management Council, 5 Broadway, Saugus, MA 01906.

Scoping meetings will be held in New Jersey, New York, Rhode Island, and Massachusetts. See **SUPPLEMENTARY INFORMATION** for locations of the meetings.

FOR FURTHER INFORMATION CONTACT: Paul J. Howard, Executive Director, (781)-231-0422.

SUPPLEMENTARY INFORMATION:

Background

Silver hake and red hake became components of the multispecies fishery management unit in Amendment 4 to the FMP (56 FR 24724, May 31, 1991). At that time, a proposed 2.5-inch (6.35-cm) minimum mesh size for whiting was considered but not approved, because NMFS determined that it would do little to prevent overfishing. Also, the economic analysis failed to demonstrate a net benefit over a 10-year period, and members of the fishing industry in the Mid-Atlantic area commented that the mesh size increase would result in a disproportionate economic cost to them. Consequently, other than the measures adopted for the Cultivator Shoal whiting fishery, no regulations controlling fishing for either whiting or red hake have been developed following their incorporation into the multispecies management unit.

Fishing for whiting, offshore hake, and red hake is currently allowed without restriction in the Mid-Atlantic Regulatory Mesh Area, and in the Southern New England and Gulf of Maine/Georges Bank Regulated Mesh Areas, in times and areas where the regulatory bycatch of groundfish commonly referred to as "regulated species" has been determined to be less than 5 percent. This exemption applies year-round in Southern New England and in Small Mesh Area 1 and Small Mesh Area 2 in the Gulf of Maine. Experimental fisheries have also been undertaken to evaluate gear modifications, such as a separator grate or a raised footrope trawl, in reducing regulated species bycatch below the maximum acceptable level.

In 1993, whiting fishers brought concerns to the Council about the emergence of an export market for juvenile whiting. The Council's Groundfish Committee (Committee) formed a Whiting Subcommittee and an industry advisory panel that outlined some objectives and measures for a whiting management plan. The Committee held scoping meetings, including two in the Mid-Atlantic area in early 1994 (March 7 in Wall, New Jersey, and March 8 in Montauk, New

York). At that time, the Council staff prepared a draft public hearing document, but the Council suspended plan development efforts while it worked on Amendment 7 to the FMP.

The Whiting Subcommittee reconvened in June 1996. According to advisors, in the period between 1993 and 1996 the juvenile whiting fishery expanded significantly, raising concerns for the health of the resource. On the recommendation of advisors and the Committee, the Council established a control date of September 9, 1996, for whiting (September 9, 1996, 61 FR 47473) and announced that it is considering limiting future access to anyone not in possession of a multispecies limited access permit as of that date.

The whiting advisors raised the issue of offshore hake, which they reported was often mixed with silver hake, but historically has not been separated at the docks for the sake of landings data. They also asked about the impact of proposed management measures for silver hake on offshore hake fishing. In response, the Council obtained a scientific report from the Northeast Fisheries Science Center in October 1996. The report summarized available information and noted that very little is known about the offshore hake species. However, the Council agreed to include offshore hake in the FMP amendment addressing whiting.

In December 1996, the Whiting Subcommittee and advisors outlined a plan for whiting management. The Subcommittee agreed that, for management purposes, the whiting resource should be divided into two stocks: A northern stock in the Georges Bank/Gulf of Maine Regulated Mesh Area, and a southern stock in the Southern New England and Mid-Atlantic Regulated Mesh Areas. The Subcommittee recommended that, for management purposes, offshore hake be treated as a component of the southern stock of silver hake and that the Cultivator Shoal whiting fishery be managed separately.

Recently, the Council designated the Whiting Subcommittee as a full standing committee, tasked with developing an amendment to the FMP to conserve whiting stocks. According to the "Report on the Status of Fisheries of the United States," prepared by NMFS in September 1997, both red hake and the southern stock of silver hake are overfished, and the northern silver hake stock is approaching an overfished condition. Consequently, according to the Sustainable Fisheries Act (SFA) amendments to the Magnuson-Stevens Fishery Conservation and Management

Act, the Council must develop measures to end overfishing and rebuild these overfished stocks by September 30, 1998.

Status of the Stocks

The last stock assessment for whiting was presented to the Council in February 1994. This assessment was hampered by several problems, particularly by uncertainty about stock boundary definitions and discarding of juveniles, and by insufficient biological sampling to determine the length and age composition of the catch. More recently, recognition that a separate species (offshore hake) has been mixed with catches of silver hake compounds the difficulty of establishing an age-based assessment.

Based on analysis of landings and trawl survey data, the last assessment concluded that the Gulf of Maine/Northern Georges Bank stock was fully exploited and at a low level of abundance, although abundance appeared to be increasing. The assessment also concluded that the Southern Georges Bank/Middle Atlantic stock is overexploited and at a low level of abundance and that abundance continues to decline.

The impact of the juvenile (whiting) fishery over the past 5 years on stock status has not been measured. Given the truncated age-structure of the population of both silver hake stocks, the juvenile fishery may be detrimental to the resource.

To date, the status of the offshore hake stock has not been formally assessed, and no overfishing definition has been developed. Offshore hake is almost indistinguishable from, and often caught in combination with, silver hake. Therefore, conservation and management measures for silver hake should also address offshore hake. The scoping process will help the Council by providing input about appropriate management measures to conserve offshore hake.

The last stock assessment for red hake was conducted in 1990 (Stock Assessment Workshop/Stock Assessment Review Committee 11). Questions still remain regarding both the boundaries and the age structures of red hake stocks. While the available data are incomplete, precautionary steps can be taken to protect the resource and allow for a balanced and sustainable fishery. Additionally, in order to comply with the mandates of the SFA, the Council must address overfishing of red hake and work to rebuild the resource to a level capable of achieving optimum yield.

Purpose

The purpose of the proposed amendment is to end and prevent overfishing on silver hake and red hake stocks, to provide basic protection for offshore hake, and to rebuild and maintain healthy spawning stocks in order to allow for a balanced, sustainable fishery that maximizes economic benefits without compromising the health of the resources.

Management Options**Moratorium on Permits—Limited Access**

The Whiting Committee recommends that, in order to land whiting, a vessel without a current limited access multispecies permit must meet the following criteria: (1) That it held an open access, nonregulated multispecies permit as of the control date (September 9, 1996), and (2) that it had landed at least one pound of whiting prior to the control date. All vessels with a current limited access multispecies permit would retain access to the whiting fishery.

Southern Stock

Management of the southern stock is complicated by the diversity of the fisheries where whiting is caught; specifically, the squid/whiting fishery uses a 1.88-inch (4.78-cm) mesh, and the other mixed-trawl fisheries use meshes of 2–2.5 inches (5–6.35 cm). The Council is considering requiring a vessel retaining whiting to use a codend of 2.5 inches (6.35 cm) or larger and to prohibit the retention of whiting on vessels using smaller mesh from June 1 to September 1 of each year. Vessels retaining whiting from September 1 through May 31 would be required to switch to a 2.5-inch (6.35-cm) mesh upon reaching a specific threshold amount of whiting on board. The minimum mesh size for retaining whiting from September 1 to May 31 would be the minimum mesh size for *Loligo* squid as determined by the Mid-Atlantic Fishery Management Council.

The Whiting Committee is also considering several options for a whiting trip limit, including a sliding scale trip limit based on overall vessel length. A trip limit may be imposed year-round or seasonally.

Northern Stock

Scientific information indicates that the northern stock may be able to sustain a fishery utilizing both small and large whiting, provided the catch is limited or controlled. The Whiting Committee intends to consider results from experimental fisheries that have

evaluated grate/mesh size management strategies. The Whiting Committee recommends requiring a vessel retaining whiting to use a codend of 2.5 inches (6.35 cm) or larger if the vessel is not in an approved fishery requiring a separator grate. The Whiting Committee is also considering the same trip limit options for the northern stock as for the southern stock.

Other Measures Under Consideration

The Council is also considering and will take comments on other management options, including (1) a minimum fish size for whiting of 11 inches (27.94 cm) with a 20-percent tolerance for undersized fish, with or without a minimum mesh size; (2) minimum mesh sizes up to 3 inches (7.62 cm), with or without a minimum fish size; (3) a square-mesh panel in the net and other gear modifications; (4) a raised footrope trawl design; (5) spawning area closures; and (6) a provision to utilize additional management tools from the FMP to manage these stocks in the future.

Scoping Process

The Council discussed and took scoping comments at a previous meeting on March 12 and 13, 1997. A notice of intent to prepare an SEIS and notice of scoping process for silver hake and offshore hake stocks was published in the Federal Register on March 19, 1997 (62 FR 12983). Because both red hake and silver hake have recently been listed as overfished, the Whiting Committee felt that reopening the scoping process was necessary to receive further comments about managing silver hake, offshore hake, and red hake. Therefore, the Council will accept public comments about the scope of whiting, offshore hake, and red hake management at its next meeting on February 25, 1998, in Portsmouth, New Hampshire. Additional scoping meetings are scheduled as follows (a notice will be published in the Federal Register at a later date giving complete addresses for the meetings):

1. March 3, 1998, 7 p.m.—Holiday Inn, Toms River, NJ.
2. March 4, 1998, 7 p.m.—Holiday Inn at MacArthur Airport, Ronkonkoma, NY.
3. March 5, 1998, 4 p.m.—Holiday Inn at the Crossings, Warwick, RI.
4. March 9, 1998, 2 p.m.—Town Hall, Provincetown, MA.

Additional meetings of the Council, Whiting Committee, or Advisory Panel during the scoping period will provide opportunities for public comments on specific issues identified in the respective agendas.

All persons affected by, or otherwise interested in, whiting and red hake fisheries management are invited to participate in determining the scope and significance of issues to be analyzed by submitting written comments (see ADDRESSES). Scope consists of the range of actions, alternatives, and impacts to be considered. Alternatives include not developing a management plan, developing amendments to existing plans, or other reasonable courses of action. Impacts may be direct, indirect, individual, or cumulative. The scoping process will also identify and eliminate from detailed study issues that are not significant. Once a draft FMP amendment and an SEIS or Environmental Assessment are developed, the Council will hold public hearings to receive comments on them.

Authority: 16 U.S.C. 1801 *et seq.*

Dated: February 4, 1998.

Bruce C. Morehead,

Acting Director, Office of Sustainable Fisheries, National Marine Fisheries Service.
[FR Doc. 98-3333 Filed 2-9-98; 8:45 am]

BILLING CODE 3510-22-F

DEPARTMENT OF COMMERCE**National Oceanic and Atmospheric Administration****50 CFR Part 648**

[I.D. 020398A]

New England Fishery Management Council; Meeting

AGENCY: National Marine Fisheries Service (NMFS), National Oceanic and Atmospheric Administration (NOAA), Commerce.

ACTION: Public meeting.

SUMMARY: The New England Fishery Management Council (Council) will hold a 2-day public meeting on February 25 and 26, 1998, to consider actions affecting New England fisheries in the exclusive economic zone.

DATES: The meeting will be held on Wednesday, February 25, 1998, at 10 a.m., and on Thursday, February 26, 1998, at 8:30 a.m.

ADDRESSES: The meeting will be held at the Sheraton Portsmouth Hotel, 250 Market Street, Portsmouth, New Hampshire 03801; telephone (603) 431-2300. Requests for special accommodations should be addressed to the New England Fishery Management Council, 5 Broadway, Saugus, Massachusetts 01906-1097; telephone: (781) 231-0422.

FOR FURTHER INFORMATION CONTACT: Paul J. Howard, Executive Director, New

England Fishery Management Council (781) 231-0422.

SUPPLEMENTARY INFORMATION:

Wednesday, February 25, 1998

After introductions, the Monkfish Committee will review public hearing comments and approve the final monkfish management measures for Amendment 9 to the Northeast Multispecies Fishery Management Plan (FMP). During the afternoon session, results of a synthesis of available scientific information about fishing gear impacts on habitat will be presented by Dr. Peter Auster, Science Director of the National Undersea Research Center at the University of Connecticut. This will be followed by an update on progress to develop essential fish habitat designations for Council-managed species and a review of the Dogfish Committee's recent meeting. The discussion will include consideration and approval of a dogfish fishery control date (which may be used in the future to establish rules to limit participation in this fishery). Next, the Whiting Committee will discuss the development of a whiting management program and its recommendations concerning several whiting exempted fisheries proposals. Prior to adjournment for the day, a scoping hearing to solicit comments on whiting management will conclude the Council meeting. The Council will ask the public to identify major issues to be considered in the development of management measures for silver hake (whiting), offshore hake, and red hake.

Thursday, February 26, 1998

The Groundfish Committee Report may approve initial action on a framework adjustment to the Northeast Multispecies FMP that would restrict the use of "streetsweeper" trawl gear. The Council may also consider including alternative measures to protect Gulf of Maine cod (contained in a proposal forwarded by the Gulf of Maine Fishermen's Alliance) in this action. The proposal would establish 2 vessel categories (inshore/offshore and offshore/trip limit exemption area), trip limits, area closures, and incentives to fish outside the Gulf of Maine. Finally, the Groundfish Committee will review progress on a plan amendment to address the Sustainable Fisheries Act (SFA) requirements. In addition to a

briefing on the recent U.S./Canada industry meeting, the Herring Committee may ask the Council to approve management alternatives for public hearing purposes (including, but not limited to, controlled access, spawning area closures, vessel/dealer/operator permit requirements, area management, a target total allowable catch level, vessel size limits, a prohibition on fishing for the purpose of meal production, limits on fishing time, and restrictions on fishing for roe). The Thursday agenda will include reports from the Council Chairman, Executive Director, Administrator, Northeast Region, NMFS (Regional Administrator), Northeast Fisheries Science Center and Mid-Atlantic Fishery Management Council liaisons, and representatives of the Coast Guard, the Atlantic States Marine Fisheries Commission, and of the U.S. Fish and Wildlife Service. The Interspecies Committee will update the Council on efforts to eliminate inconsistencies in vessel upgrading, replacement, and permit-splitting restrictions, including asking the Council to approve measures to eliminate upgrading restrictions on boats less than 30 ft (9.1 m). It will review comments on the Atlantic States Coastal Cooperative Statistics Program fishing vessel logbook form and discuss the development of a policy on harvesting innovations and new fisheries technology. The Overfishing Definition Review Panel will review the overfishing definitions for sea herring, silver hake, and possibly other species. The Sea Scallop Committee will discuss its progress on a plan amendment to address SFA requirements, the development of criteria for opening and closing management areas and on its discussions of days-at-sea leasing and an industry-funded vessel buyout program.

The Regional Administrator will consult with the Council regarding a proposal from Soren Henriksen of the Westport Scalloping Corporation to conduct an experimental fishery to harvest seed scallops with a small mesh-lined scallop dredge in the Nantucket Lightship Closed Area (NLCA). There will be a discussion and opportunity for public comment. This proposal authorizes additional activities to facilitate the sea scallop aquaculture research project approved last winter under Amendment 5 to the Atlantic Sea

Scallop Fishery Management Plan. The applicant cites problems with harvesting seed scallops from distant areas and off-loading to the test site (20 hours steam). The 1997 NMFS sea scallop survey indicates the presence of mixed scallop beds containing seed within the northeast part of the NLCA (survey stations #238-241). The area is currently closed to scallop dredge vessels under the northeast multispecies regulations. The experiment would authorize one limited access scallop vessel to catch and retain a maximum of 1500 bushels (528.6 hl) of seed scallops with a small mesh-lined scallop dredge from the NLCA and off-load to the Scallop Experimental Fishing Area (five hours steam). The vessel would be given a 2-day exemption from the days-at-sea reporting requirements while collecting seed scallops in the NLCA. The experiment is intended to allow the harvesting of seed scallops to support the ongoing sea scallop aquaculture research project aimed at developing techniques and practices that could allow the scallop fishery to evolve from one based exclusively on wild-capture to an industry that also incorporates modern husbandry, enhancement, and open-ocean cage culture. The Council meeting will adjourn after the conclusion of any other outstanding Council business.

Although other issues not contained in this agenda may come before this Council for discussion, in accordance with the Magnuson-Stevens Fishery Conservation and Management Act, those issues may not be the subject of formal Council action during this meeting. Council action will be restricted to those issues specifically listed in this notice.

Special Accommodations

This meeting is physically accessible to people with disabilities. Requests for sign language interpretation or other auxiliary aids should be directed to Paul J. Howard (see ADDRESSES) at least 5 days prior to the meeting date.

Authority: 16 U.S.C. 1801 *et seq.*

Dated: February 4, 1998.

Gary Matlock,

Director, Office of Sustainable Fisheries, National Marine Fisheries Service.

[FR Doc. 98-3332 Filed 2-9-98; 8:45 am]

BILLING CODE 3510-22-F

Notices

Federal Register

Vol. 63, No. 27

Tuesday, February 10, 1998

This section of the FEDERAL REGISTER contains documents other than rules or proposed rules that are applicable to the public. Notices of hearings and investigations, committee meetings, agency decisions and rulings, delegations of authority, filing of petitions and applications and agency statements of organization and functions are examples of documents appearing in this section.

AFRICAN DEVELOPMENT FOUNDATION

Sunshine Act Meeting

Board of Directors Meeting

TIME: 9:00 a.m.–12:00 noon.

PLACE: ADF Headquarters.

DATE: Wednesday, February 11, 1998

STATUS: Open.

Agenda

Wednesday, February 11, 1998.

9:00 a.m. Chairman's Report

10:00 a.m. President's Report

12:00 noon Adjournment

If you have any questions or comments, please direct them to Ms. Janis McCollim, Executive Assistant to the President, who can be reached at (202) 673-3916.

William R. Ford,

President.

[FR Doc. 98-3425 Filed 2-6-98; 11:50 am]

BILLING CODE 6116-01-P

DEPARTMENT OF AGRICULTURE

Research, Education, and Economics; Notice of Strategic Planning Task Force Meeting

AGENCY: Research, Education, and Economics, USDA.

ACTION: Notice of meeting.

SUMMARY: The United States Department of Agriculture announces a meeting of the Strategic Planning Task Force on Research Facilities.

SUPPLEMENTARY INFORMATION: The Strategic Planning Task Force on Research Facilities, currently consisting of 14 members, is scheduled to meet for the fourth of eight planned meetings. The meeting is scheduled to be held at the Baton Rouge Hilton, Baton Rouge, Louisiana, beginning at 2:00 p.m. on February 22 and concluding at 3:00 p.m. on February 24. The meeting will be a

review of the Task Force progress in data collection and will devote 1 day to a discussion regarding the proposed instrument to evaluate intramural facilities.

Times and Dates: February 22, 1998, at 2:00 p.m.; February 23, 1998, 8:00 a.m.–5:00 p.m.; and February 24, 1998, 8:00 a.m.–3:00 p.m.

Place: Baton Rouge Hilton, Baton Rouge, Louisiana.

Type of Meeting: Open to the public.

Comments: The public may file written comments before or after the meeting with the contact person listed below.

FOR FURTHER INFORMATION CONTACT: Mitch Geasler, Project Director, Strategic Planning Task Force on Research Facilities, Room 344-A, Jamie L. Whitten Building, USDA, 1400 Independence Avenue, SW., Washington, D.C. 20250-0113. Telephone 202-720-3803.

Done at Washington, D.C., on this 3rd Day of February 1998.

I. Miley Gonzalez,

Under Secretary, Research, Education, and Economics.

[FR Doc. 98-3273 Filed 2-9-98; 8:45 am]

BILLING CODE 3410-22-P

DEPARTMENT OF AGRICULTURE

Animal and Plant Health Inspection Service

[Docket No. 97-091-2]

AgrEvo USA Co.; Availability of Determination of Nonregulated Status for Canola Genetically Engineered for Glufosinate Herbicide Tolerance

AGENCY: Animal and Plant Health Inspection Service, USDA.

ACTION: Notice.

SUMMARY: We are advising the public of our determination that AgrEvo USA Company's canola designated as Transformation Event T45, which has been genetically engineered for tolerance to the herbicide glufosinate, is no longer considered a regulated article under our regulations governing the introduction of certain genetically engineered organisms. Our determination is based on our evaluation of data submitted by AgrEvo USA Company in its petition for a determination of nonregulated status

and an analysis of other scientific data. This notice also announces the availability of our written determination document and its associated environmental assessment and finding of no significant impact.

EFFECTIVE DATE: January 29, 1998.

ADDRESSES: The determination, an environmental assessment and finding of no significant impact, and the petition may be inspected at USDA, room 1141, South Building, 14th Street and Independence Avenue SW., Washington, DC, between 8 a.m. and 4:30 p.m., Monday through Friday, except holidays. Persons wishing to inspect those documents are asked to call in advance of visiting at (202) 690-2817 to facilitate entry into the reading room.

FOR FURTHER INFORMATION CONTACT: Dr. James Lackey, Biotechnology Evaluation, BSS, PPQ, APHIS, 4700 River Road Unit 147, Riverdale, MD 20737-1236; (301) 734-6748. To obtain a copy of the determination or the environmental assessment and finding of no significant impact, contact Ms. Kay Peterson at (301) 734-4885; e-mail: mkpeterson@aphis.usda.gov.

SUPPLEMENTARY INFORMATION:

Background

On July 24, 1997, the Animal and Plant Health Inspection Service (APHIS) received a petition (APHIS Petition No. 97-205-01p) from AgrEvo USA Company (AgrEvo) of Wilmington, DE, seeking a determination that canola (*Brassica napus* L.) designated as Transformation Event T45 (event T45), which has been genetically engineered for tolerance to the herbicide glufosinate, does not present a plant pest risk and, therefore, is not a regulated article under APHIS' regulations in 7 CFR part 340.

On September 30, 1997, APHIS published a notice in the *Federal Register* (62 FR 51081-51082, Docket No. 97-091-1) announcing that the AgrEvo petition had been received and was available for public review. The notice also discussed the role of APHIS, the Environmental Protection Agency, and the Food and Drug Administration in regulating the subject canola and food products derived from it. In the notice, APHIS solicited written comments from the public as to whether this canola posed a plant pest risk. The comments were to have been received by APHIS on

or before December 1, 1997. APHIS received no comments on the subject petition during the designated 60-day comment period.

Analysis

Event T45 canola has been genetically engineered to contain a *pat* gene derived from *Streptomyces viridochromogenes*. The *pat* gene encodes the enzyme phosphinothricin-N-acetyltransferase (PAT), which confers tolerance to the herbicide glufosinate. Expression of the *pat* gene is controlled by a 35S promoter and terminator derived from the plant pathogen cauliflower mosaic virus. The *Agrobacterium tumefaciens* method was used to transfer the added genes into the parental cultivar *B. napus* var. AC EXCEL.

The subject canola has been considered a regulated article under APHIS' regulations in 7 CFR part 340 because it contains gene sequences derived from plant pathogens. However, evaluation of field data reports from field tests of this canola conducted under APHIS permits since 1996 indicates that there were no deleterious effects on plants, nontarget organisms, or the environment as a result of the environmental release of event T45 canola.

Determination

Based on its analysis of the data submitted by AgrEvo, and a review of other scientific data and field tests of the subject canola, APHIS has determined that event T45 canola: (1) Exhibits no plant pathogenic properties; (2) is no more likely to become a weed than canola developed by traditional breeding techniques; (3) is unlikely to increase the weediness potential for any other cultivated or wild species with which it can interbreed; (4) will not cause damage to raw or processed agricultural commodities; and (5) will not harm threatened or endangered species or other organisms, such as bees, that are beneficial to agriculture. Therefore, APHIS has concluded that the subject canola and any progeny derived from hybrid crosses with other nontransformed canola varieties will be as safe to grow as canola in traditional breeding programs that are not subject to regulation under 7 CFR part 340.

The effect of this determination is that AgrEvo's event T45 canola is no longer considered a regulated article under APHIS' regulations in 7 CFR part 340. Therefore, the requirements pertaining to regulated articles under those regulations no longer apply to the subject canola of its progeny. However, importation of the subject canola or seeds capable of propagation are still

subject to the restrictions found in APHIS' foreign quarantine notices in 7 CFR part 319.

National Environmental Policy Act

An environmental assessment (EA) has been prepared to examine the potential environmental impacts associated with this determination. The EA was prepared in accordance with: (1) The National Environmental Policy Act of 1969 (NEPA), as amended (42 U.S.C. 4321 *et seq.*), (2) regulations of the Council on Environmental Quality for implementing the procedural provisions of NEPA (40 CFR parts 1500-1508), (3) USDA regulations implementing NEPA (7 CFR part 1b), and (4) APHIS' NEPA Implementing Procedures (7 CFR part 372). Based on that EA, APHIS has reached a finding of no significant impact (FONSI) with regard to its determination that AgrEvo's event T45 canola and lines developed from it are no longer regulated articles under its regulations in 7 CFR part 340. Copies of the EA and the FONSI are available upon request from the individual listed under **FOR FURTHER INFORMATION CONTACT**.

Done in Washington, DC, this 4th day of January 1998.

Terry L. Medley,
Administrator, Animal and Plant Health Inspection Service.

[FR Doc. 98-3312 Filed 2-9-98; 8:45 am]

BILLING CODE 3410-34-P

DEPARTMENT OF AGRICULTURE

Animal and Plant Health Inspection Service

[Docket No. 98-008-1]

Public Meeting; Animal Care

AGENCY: Animal and Plant Health Inspection Service, USDA.

ACTION: Advance notice of public meeting and request for agenda topics.

SUMMARY: The Animal and Plant Health Inspection Service plans to hold a public meeting to discuss the animal welfare program and initiatives. This notice solicits suggestions for the agenda for this meeting.

PLACE, DATES, AND TIME OF MEETING: The public meeting will be held at the USDA Conference Center, 4700 River Road, Riverdale, MD 20737, on Tuesday, May 12, 1998. Registration will take place from 7 a.m. to 9 a.m. The meeting will begin at 9 a.m. and end at approximately 5 p.m.

FOR FURTHER INFORMATION CONTACT: For further information on agenda topics

contact Dr. Ron DeHaven, Acting Deputy Administrator, Animal Care, APHIS, 4700 River Road Unit 84, Riverdale, MD 20737, (301) 734-4981, FAX (301) 734-4328 or 734-4978.

SUPPLEMENTARY INFORMATION: The Animal and Plant Health Inspection Service (APHIS) will hold a public meeting in Riverdale, MD, on May 12, 1998, to exchange information with the public about the animal welfare program and initiatives.

The meeting will include a general information session followed by individual workshops on a variety of topics. APHIS is seeking suggestions for meeting topics from the general public, animal researchers, exhibitors, dealers, transporters, and animal protection groups.

Please submit, on or before March 16, 1998, suggestions regarding animal welfare issues of common concern to the person listed under **FOR FURTHER INFORMATION CONTACT**. Please note that this is not an opportunity to submit formal comments on proposed rules or other regulatory initiatives, but rather is intended to help determine which animal welfare issues and initiatives should be addressed at the public meeting.

After the agenda is finalized, APHIS will announce the schedule in the **Federal Register**.

Done in Washington, DC, this 4th day of February 1998.

Terry L. Medley,
Administrator, Animal and Plant Health Inspection Service.

[FR Doc. 98-3313 Filed 2-9-98; 8:45 am]

BILLING CODE 3410-34-P

DEPARTMENT OF AGRICULTURE

Forest Service

Committee of Scientists Meetings

AGENCY: Forest Service, USDA.

ACTION: Notice of meetings.

SUMMARY: Meetings of the Committee of Scientists are scheduled for February 24-25, 1998 in Atlanta, Georgia and March 3-5, 1998, in Sacramento, California. The purpose of the Atlanta meeting is to discuss planning issues concerning the National Forests in the Southern Region (Alabama, Arkansas, Florida, Georgia, Kentucky, Louisiana, Mississippi, Oklahoma, Puerto Rico, South Carolina, Tennessee, Texas, Virgin Islands, and Virginia). The purpose of the Sacramento meeting is to discuss planning issues concerning the Pacific Southwest Region (California, Hawaii, Guam and Trust Territories of

the Pacific Islands). The Committee will meet with representatives from federal, state, and local organizations; will share information and ideas about Committee members' assignments; will continue discussions on the scientific principles underlying land and resource management; and will conduct any other Committee business that may arise. The meetings are open to the public, with opportunities for the public to address the Committee.

DATES: The Atlanta meeting is scheduled for February 24–25, 1998, and the Sacramento meeting for March 3–5, 1998.

ADDRESSES: The Atlanta meeting will be held at the Harvey Hotel, 6345 Powers Ferry Road NW, Atlanta, Georgia. The Sacramento meeting will be held at the Ramada Inn, 2600 Auburn Boulevard, Sacramento, California.

Written comments on improving land and resource management planning may be sent to the Committee of Scientists, P.O. Box 2140, Corvallis, OR 97339. Also, the Committee may be accessed via the Internet at www.cof.orst.edu/org/scicomm/.

FOR FURTHER INFORMATION CONTACT: Bob Cunningham, Designated Federal Official to the Committee of Scientists, telephone: 202–205–2494.

SUPPLEMENTARY INFORMATION: The Atlanta meeting to discuss planning issues concerning the National Forests in the Southern Region will begin at 9 a.m. and end at 7 p.m. on February 24. On February 25, the meeting will begin at 8 a.m. and end at 4 p.m. Citizens may address the Committee on February 24, beginning at 4 p.m., to present ideas on how to improve National Forest System land and resource management planning.

The Sacramento meeting to discuss planning issues concerning the Pacific Southwest Region will begin at 1 p.m. and end at 5 p.m. on March 3. On March 4, the meeting will begin at 8 a.m. and end at 7 p.m. and, on March 5, the meeting will begin at 8 a.m. and end at 4 p.m. Citizens may address the Committee on March 4, beginning at 4 p.m., to present ideas on how to improve National Forest System land and resource management planning.

Citizens who wish to speak at either meeting must register at that meeting before 5 p.m. Each speaker will be limited to a maximum of 5 minutes. Persons may also submit written suggestions to the Committee at either meeting or by mail at the addresses listed under the **ADDRESSES** heading.

The Committee of Scientists is chartered to provide scientific and technical advice to the Secretary of

Agriculture and the Chief of the Forest Service on improvements that can be made to the National Forest System land and resource management planning process (62 FR 43691; August 15, 1997). Notice of the names of the appointed Committee members was published December 16, 1997 (62 FR 65795). Agendas and locations for future meetings will be published as separate notices in the **Federal Register**.

Dated: January 5, 1998.

Robert C. Joslin,

Deputy Chief for National Forest System.

[FR Doc. 98–3337 Filed 2–9–98; 8:45 am]

BILLING CODE 3410–11–M

ASSASSINATION RECORDS REVIEW BOARD

Formal Determinations, Additional Releases, and Assassination Records Designations

AGENCY: Assassination Records Review Board.

ACTION: Notice.

SUMMARY: The Assassination Records Review Board (Review Board) met in a closed meeting on January 22, 1998, and made formal determinations on the release of records under the President John F. Kennedy Assassination Records Collection Act of 1992 (JFK Act). By issuing this notice, the Review Board complies with the section of the JFK Act that requires the Review Board to publish the results of its decisions on a document-by-document basis in the **Federal Register** within 14 days of the date of the decision.

FOR FURTHER INFORMATION CONTACT: Peter Voht, Assassination Records Review Board, Second Floor, Washington, D.C. 20530, (202) 724–0088, fax (202) 724–0457.

SUPPLEMENTARY INFORMATION: This notice complies with the requirements of the President John F. Kennedy Assassination Records Collection Act of 1992, 44 U.S.C. 2107.9(c)(4)(A) (1992). On January 22, 1998, the Review Board made formal determinations on records it reviewed under the JFK Act. These determinations are listed below. The assassination records are identified by the record identification number assigned in the President John F. Kennedy Assassination Records Collection database maintained by the National Archives.

Notice of Formal Determinations

For each document, the number of postponements sustained immediately follows the record identification

number, followed, where appropriate, by the date the document is scheduled to be released or re-reviewed.

CIA Documents: Postponed in Part

104–10050–10003; 6; 10/2017
 104–10054–10059; 6; 10/2017
 104–10054–10284; 6; 10/2017
 104–10059–10270; 6; 10/2017
 104–10066–10076; 7; 10/2017
 104–10092–10193; 1; 10/2017
 104–10092–10219; 1; 10/2017
 104–10092–10263; 2; 10/2017
 104–10092–10267; 1; 10/2017
 104–10092–10340; 28; 10/2017
 104–10092–10453; 2; 10/2017
 104–10092–10456; 1; 10/2017
 104–10093–10257; 1; 10/2017
 104–10093–10266; 16; 10/2017
 104–10093–10275; 1; 10/2017
 104–10093–10278; 1; 10/2017
 104–10093–10279; 1; 10/2017
 104–10093–10281; 2; 10/2017
 104–10093–10283; 4; 10/2017
 104–10093–10299; 11; 10/2017
 104–10093–10300; 4; 10/2017
 104–10093–10301; 1; 10/2017
 104–10093–10303; 2; 10/2017
 104–10093–10304; 1; 10/2017
 104–10093–10310; 10; 10/2017
 104–10093–10317; 1; 10/2017
 104–10093–10326; 3; 10/2017
 104–10093–10331; 3; 10/2017
 104–10093–10333; 21; 10/2017
 104–10093–10334; 1; 10/2017
 104–10093–10341; 16; 10/2017
 104–10093–10342; 2; 10/2017
 104–10093–10344; 14; 10/2017
 104–10093–10352; 1; 10/2017
 104–10093–10353; 3; 10/2017
 104–10093–10359; 1; 10/2017
 104–10093–10370; 2; 10/2017
 104–10093–10371; 2; 10/2017
 104–10093–10377; 1; 10/2017
 104–10097–10200; 1; 10/2017
 104–10097–10201; 1; 10/2017
 104–10097–10202; 4; 10/2017
 104–10097–10203; 10; 10/2017
 104–10097–10204; 1; 10/2017
 104–10097–10211; 1; 10/2017
 104–10097–10220; 2; 10/2017
 104–10097–10232; 1; 10/2017
 104–10097–10234; 3; 10/2017
 104–10097–10235; 3; 10/2017
 104–10097–10240; 4; 10/2017
 104–10097–10245; 9; 10/2017
 104–10097–10248; 6; 10/2017
 104–10097–10254; 4; 10/2017
 104–10097–10255; 4; 10/2017
 104–10097–10259; 1; 10/2017
 104–10097–10260; 2; 10/2017
 104–10097–10262; 7; 10/2017
 104–10097–10265; 1; 10/2017
 104–10097–10289; 1; 10/2017
 104–10097–10290; 1; 10/2017
 104–10097–10297; 6; 10/2017
 104–10097–10299; 2; 10/2017
 104–10097–10300; 10; 10/2017
 104–10097–10301; 2; 10/2017
 104–10097–10302; 11; 10/2017
 104–10097–10306; 5; 10/2017
 104–10097–10307; 6; 10/2017
 104–10097–10316; 10; 10/2017
 104–10097–10319; 1; 10/2017
 104–10097–10320; 12; 10/2017
 104–10097–10325; 2; 10/2017

104-10097-10326; 1; 10/2017
104-10097-10329; 11; 10/2017
104-10097-10330; 17; 10/2017
104-10097-10334; 8; 10/2017
104-10097-10345; 1; 10/2017
104-10097-10360; 3; 10/2017
104-10097-10362; 1; 10/2017
104-10097-10363; 4; 10/2017
104-10097-10368; 19; 10/2017
104-10097-10401; 1; 10/2017
104-10097-10402; 1; 10/2017
104-10102-10053; 6; 10/2017
104-10106-10071; 2; 10/2017
104-10106-10077; 6; 10/2017
104-10106-10092; 2; 10/2017
104-10106-10126; 3; 10/2017
104-10106-10188; 9; 10/2017
104-10106-10190; 1; 10/2017
104-10106-10753; 1; 10/2017
104-10107-10028; 2; 10/2017
104-10107-10030; 3; 10/2017
104-10115-10090; 2; 10/2017
104-10119-10055; 3; 10/2017
104-10119-10056; 1; 10/2017
104-10119-10057; 1; 10/2017
104-10119-10059; 6; 10/2017
104-10119-10061; 3; 10/2017
104-10119-10068; 1; 10/2017
104-10119-10070; 1; 10/2017
104-10119-10071; 2; 10/2017
104-10119-10085; 1; 10/2017
104-10119-10112; 14; 10/2017
104-10119-10114; 1; 10/2017
104-10119-10115; 2; 10/2017
104-10119-10125; 1; 10/2017
104-10119-10126; 5; 10/2017
104-10119-10128; 2; 10/2017
104-10119-10132; 1; 10/2017
104-10119-10133; 1; 10/2017
104-10119-10134; 2; 10/2017
104-10119-10142; 3; 10/2017
104-10119-10143; 6; 10/2017
104-10119-10169; 1; 10/2017
104-10119-10176; 1; 10/2017
104-10119-10182; 17; 10/2017
104-10119-10185; 12; 10/2017
104-10120-10078; 24; 10/2017
104-10120-10079; 20; 10/2017
104-10120-10341; 11; 10/2017
104-10120-10348; 2; 10/2017
104-10120-10350; 1; 10/2017
104-10120-10356; 4; 10/2017
104-10121-10060; 16; 10/2017
104-10121-10061; 4; 10/2017
104-10121-10062; 4; 10/2017
104-10121-10093; 1; 10/2017
104-10121-10097; 2; 10/2017
104-10121-10101; 1; 10/2017
104-10121-10111; 1; 10/2017
104-10121-10120; 1; 10/2017
104-10121-10122; 1; 10/2017
104-10121-10124; 1; 10/2017
104-10121-10125; 1; 10/2017
104-10121-10129; 1; 10/2017
104-10121-10132; 18; 10/2017
104-10121-10140; 9; 10/2017
104-10121-10143; 1; 10/2017
104-10121-10147; 2; 10/2017
104-10121-10148; 1; 10/2017
104-10121-10155; 1; 10/2017
104-10121-10156; 1; 10/2017
104-10121-10157; 1; 10/2017
104-10121-10158; 1; 10/2017
104-10121-10160; 1; 10/2017
104-10121-10172; 3; 10/2017
104-10121-10174; 33; 10/2017
104-10121-10191; 17; 10/2017
104-10121-10202; 1; 10/2017
104-10121-10203; 1; 10/2017
104-10121-10207; 1; 10/2017
104-10121-10220; 3; 10/2017
104-10121-10223; 2; 10/2017
104-10121-10227; 3; 10/2017
104-10121-10228; 1; 10/2017
104-10121-10236; 22; 10/2017
104-10121-10237; 12; 10/2017
104-10121-10239; 7; 10/2017
104-10121-10243; 1; 10/2017
104-10121-10246; 1; 10/2017
104-10121-10248; 1; 10/2017
104-10121-10253; 8; 10/2017
104-10121-10257; 5; 10/2017
104-10121-10258; 6; 10/2017
104-10121-10259; 3; 10/2017
104-10121-10273; 6; 10/2017
104-10121-10282; 2; 10/2017
104-10121-10285; 1; 10/2017
104-10121-10286; 1; 10/2017
104-10121-10287; 1; 10/2017
104-10121-10289; 1; 10/2017
104-10121-10299; 1; 10/2017
104-10121-10303; 2; 10/2017
104-10121-10306; 2; 10/2017
104-10121-10307; 1; 10/2017
104-10121-10309; 1; 10/2017
104-10121-10315; 1; 10/2017
104-10121-10319; 1; 10/2017
104-10121-10320; 5; 10/2017
104-10121-10321; 9; 10/2017
104-10121-10323; 2; 10/2017
104-10121-10330; 1; 10/2017
104-10124-10332; 3; 10/2017
104-10124-10333; 1; 10/2017
104-10128-10151; 12; 10/2017
104-10129-10134; 2; 10/2017
104-10129-10138; 27; 10/2017
104-10129-10141; 3; 10/2017
104-10129-10143; 5; 10/2017
104-10129-10146; 3; 10/2017
104-10129-10148; 5; 10/2017
104-10129-10155; 4; 10/2017
104-10143-10056; 5; 10/2017
104-10143-10058; 2; 10/2017
104-10144-10022; 2; 10/2017
104-10146-10198; 15; 10/2017
104-10146-10204; 2; 10/2017
104-10150-10003; 2; 10/2017
104-10161-10091; 18; 10/2017
104-10162-10000; 19; 10/2017
104-10162-10001; 5; 10/2017
104-10162-10002; 1; 10/2017
104-10162-10003; 1; 10/2017
104-10162-10004; 3; 10/2017
104-10162-10005; 5; 10/2017
104-10162-10006; 6; 10/2017
104-10162-10007; 3; 10/2017
104-10162-10008; 14; 10/2017
104-10162-10009; 3; 10/2017
104-10162-10010; 5; 10/2017
104-10162-10011; 1; 10/2017
104-10162-10012; 2; 10/2017
104-10162-10013; 3; 10/2017
104-10162-10014; 11; 10/2017
104-10162-10015; 5; 10/2017
104-10162-10016; 4; 10/2017
104-10162-10017; 6; 10/2017
104-10162-10018; 4; 10/2017
104-10162-10019; 5; 10/2017
104-10162-10020; 4; 10/2017
104-10162-10021; 3; 10/2017
104-10162-10024; 1; 05/2001
104-10162-10025; 2; 10/2017
104-10162-10026; 2; 10/2017
104-10162-10027; 1; 10/2017
104-10162-10028; 2; 10/2017
104-10162-10029; 6; 10/2017
104-10162-10030; 1; 10/2017
104-10162-10031; 14; 10/2017
104-10162-10032; 3; 10/2017
104-10162-10033; 3; 10/2017
104-10162-10034; 2; 10/2017
104-10162-10035; 4; 10/2017
104-10162-10037; 3; 10/2017
104-10162-10038; 4; 10/2017
104-10162-10039; 4; 10/2017
104-10162-10040; 6; 10/2017
104-10162-10041; 1; 10/2017
104-10162-10042; 4; 10/2017
104-10162-10043; 3; 10/2017
104-10162-10044; 11; 10/2017
104-10162-10045; 1; 10/2017
104-10162-10046; 3; 10/2017
104-10162-10047; 9; 10/2017
104-10162-10048; 1; 10/2017
104-10162-10049; 3; 10/2017
104-10162-10050; 3; 10/2017
104-10162-10051; 9; 10/2017
104-10162-10052; 2; 10/2017
104-10162-10053; 2; 10/2017
104-10162-10054; 8; 10/2017
104-10162-10055; 1; 10/2017
104-10162-10056; 3; 10/2017
104-10162-10057; 2; 10/2017
104-10162-10058; 10; 10/2017
104-10162-10059; 3; 10/2017
104-10162-10060; 3; 10/2017
104-10162-10061; 1; 10/2017
104-10162-10062; 1; 10/2017
104-10162-10063; 3; 10/2017
104-10162-10064; 1; 10/2017
104-10162-10065; 3; 10/2017
104-10162-10066; 5; 10/2017
104-10162-10067; 6; 10/2017
104-10162-10068; 2; 10/2017
104-10162-10069; 1; 10/2017
104-10162-10070; 6; 10/2017
104-10162-10071; 1; 10/2017
104-10162-10072; 2; 10/2017
104-10162-10073; 1; 10/2017
104-10162-10074; 12; 10/2017
104-10162-10075; 2; 10/2017
104-10162-10076; 2; 10/2017
104-10162-10077; 1; 10/2017
104-10162-10078; 1; 10/2017
104-10162-10079; 1; 10/2017
104-10162-10080; 2; 10/2017
104-10162-10081; 3; 10/2017
104-10162-10082; 4; 10/2017
104-10162-10083; 2; 10/2017
104-10162-10084; 1; 10/2017
104-10162-10085; 2; 10/2017
104-10162-10086; 5; 10/2017
104-10162-10154; 1; 10/2017
104-10162-10155; 2; 10/2017
104-10162-10156; 4; 10/2017
104-10162-10157; 1; 10/2017
104-10162-10158; 4; 10/2017
104-10162-10159; 2; 10/2017
104-10162-10160; 2; 10/2017
104-10162-10161; 2; 10/2017
104-10162-10162; 2; 10/2017
104-10162-10163; 1; 10/2017
104-10162-10164; 1; 10/2017
104-10162-10165; 1; 10/2017
104-10162-10166; 1; 10/2017
104-10162-10168; 1; 10/2017
104-10162-10169; 1; 10/2017
104-10162-10171; 1; 10/2017

104-10162-10172; 2; 10/2017
104-10162-10173; 1; 10/2017
104-10162-10174; 2; 10/2017
104-10162-10175; 5; 10/2017
104-10162-10176; 9; 10/2017
104-10162-10177; 1; 10/2017
104-10162-10178; 3; 10/2017
104-10162-10179; 5; 10/2017
104-10162-10180; 4; 10/2017
104-10162-10181; 3; 10/2017
104-10162-10182; 5; 10/2017
104-10162-10183; 1; 10/2017
104-10162-10184; 5; 10/2017
104-10162-10185; 5; 10/2017
104-10162-10187; 1; 10/2017
104-10162-10188; 6; 10/2017
104-10162-10189; 1; 10/2017
104-10162-10190; 2; 10/2017
104-10162-10191; 1; 10/2017
104-10162-10192; 2; 10/2017
104-10162-10193; 1; 10/2017
104-10162-10194; 4; 10/2017
104-10162-10195; 3; 10/2017
104-10162-10196; 1; 10/2017
104-10162-10197; 2; 10/2017
104-10162-10199; 1; 10/2017
104-10162-10200; 2; 10/2017
104-10162-10201; 1; 10/2017
104-10162-10202; 5; 10/2017
104-10162-10203; 1; 10/2017
104-10162-10205; 1; 10/2017
104-10162-10208; 1; 10/2017
104-10162-10209; 3; 10/2017
104-10162-10211; 2; 10/2017
104-10162-10214; 1; 10/2017
104-10162-10220; 3; 10/2017
104-10162-10221; 1; 10/2017
104-10162-10222; 1; 10/2017
104-10162-10223; 1; 10/2017
104-10162-10224; 1; 10/2017
104-10162-10225; 1; 10/2017
104-10162-10226; 1; 10/2017
104-10162-10227; 1; 10/2017
104-10162-10229; 7; 10/2017
104-10162-10230; 1; 10/2017
104-10162-10231; 3; 10/2017
104-10162-10232; 3; 10/2017
104-10162-10233; 17; 10/2017
104-10162-10234; 3; 10/2017
104-10162-10235; 1; 10/2017
104-10162-10236; 3; 10/2017
104-10162-10237; 1; 10/2017
104-10162-10238; 1; 10/2017
104-10162-10239; 1; 10/2017
104-10163-10003; 5; 10/2017
104-10163-10004; 2; 10/2017
104-10163-10006; 10; 10/2017
104-10163-10007; 3; 10/2017
104-10163-10011; 33; 10/2017
104-10163-10012; 42; 10/2017
104-10163-10015; 23; 10/2017
104-10163-10023; 1; 10/2017
104-10163-10027; 7; 10/2017
104-10163-10030; 3; 10/2017
104-10163-10031; 3; 10/2017
104-10163-10034; 1; 10/2017
104-10163-10035; 1; 10/2017
104-10163-10036; 1; 10/2017
104-10163-10037; 1; 10/2017
104-10163-10038; 1; 10/2017
104-10163-10039; 1; 10/2017
104-10163-10040; 1; 10/2017
104-10163-10042; 7; 10/2017
104-10163-10043; 2; 10/2017
104-10163-10044; 1; 10/2017
104-10163-10045; 1; 10/2017
104-10163-10046; 1; 10/2017
104-10163-10047; 1; 10/2017
104-10163-10048; 1; 10/2017
104-10163-10049; 2; 10/2017
104-10163-10050; 2; 10/2017
104-10163-10051; 1; 10/2017
104-10163-10052; 2; 10/2017
104-10163-10053; 3; 10/2017
104-10163-10054; 1; 10/2017
104-10163-10055; 1; 10/2017
104-10163-10056; 2; 10/2017
104-10163-10057; 1; 10/2017
104-10163-10058; 1; 10/2017
104-10163-10059; 1; 10/2017
104-10163-10060; 2; 10/2017
104-10163-10061; 1; 10/2017
104-10163-10062; 2; 10/2017
104-10163-10063; 1; 10/2017
104-10163-10064; 6; 10/2017
104-10163-10065; 3; 10/2017
104-10163-10066; 1; 10/2017
104-10163-10067; 5; 10/2017
104-10163-10068; 3; 10/2017
104-10163-10069; 2; 10/2017
104-10163-10070; 1; 10/2017
104-10163-10071; 1; 10/2017
104-10163-10072; 1; 10/2017
104-10163-10073; 1; 10/2017
104-10163-10074; 1; 10/2017
104-10163-10075; 2; 10/2017
104-10163-10076; 1; 10/2017
104-10163-10077; 1; 10/2017
104-10163-10078; 1; 10/2017
104-10163-10079; 1; 10/2017
104-10163-10081; 1; 10/2017
104-10163-10082; 2; 10/2017
104-10163-10083; 1; 10/2017
104-10163-10091; 1; 10/2017
104-10163-10092; 1; 10/2017
104-10163-10093; 1; 10/2017
104-10163-10094; 1; 10/2017
104-10163-10096; 1; 10/2017
104-10163-10097; 3; 10/2017
104-10163-10100; 3; 10/2017
104-10163-10101; 1; 10/2017
104-10163-10102; 1; 10/2017
104-10163-10105; 2; 10/2017
104-10163-10106; 3; 10/2017
104-10163-10107; 2; 10/2017
104-10163-10108; 2; 10/2017
104-10163-10109; 3; 10/2017
104-10163-10110; 1; 10/2017
104-10163-10111; 2; 10/2017
104-10163-10112; 4; 10/2017
104-10163-10113; 1; 10/2017
104-10163-10114; 4; 10/2017
104-10163-10115; 1; 10/2017
104-10163-10116; 1; 10/2017
104-10163-10117; 1; 10/2017
104-10163-10118; 3; 10/2017
104-10163-10120; 2; 10/2017
104-10163-10121; 1; 10/2017
104-10163-10124; 1; 10/2017
104-10163-10125; 1; 10/2017
104-10163-10126; 2; 10/2017
104-10163-10127; 1; 10/2017
104-10163-10128; 7; 10/2017
104-10163-10129; 5; 10/2017
104-10163-10131; 3; 10/2017
104-10163-10134; 1; 10/2017
104-10163-10136; 3; 10/2017
104-10163-10137; 1; 10/2017
104-10163-10138; 2; 10/2017
104-10163-10143; 1; 10/2017
104-10163-10145; 5; 10/2017
104-10163-10146; 3; 10/2017
104-10163-10147; 2; 10/2017
104-10163-10148; 1; 10/2017
104-10163-10149; 1; 10/2017
104-10163-10150; 1; 10/2017
104-10163-10151; 1; 10/2017
104-10163-10152; 1; 10/2017
104-10163-10153; 1; 10/2017
104-10163-10154; 1; 10/2017
104-10163-10155; 1; 10/2017
104-10163-10156; 1; 10/2017
104-10163-10157; 1; 10/2017
104-10163-10158; 1; 10/2017
104-10163-10159; 1; 10/2017
104-10163-10160; 5; 10/2017
104-10163-10161; 1; 10/2017
104-10163-10162; 5; 10/2017
104-10163-10163; 2; 10/2017
104-10163-10164; 6; 10/2017
104-10163-10165; 4; 10/2017
104-10163-10166; 1; 10/2017
104-10163-10167; 11; 10/2017
104-10163-10168; 1; 10/2017
104-10163-10169; 4; 10/2017
104-10163-10170; 8; 10/2017
104-10163-10171; 1; 10/2017
104-10163-10172; 1; 10/2017
104-10163-10175; 8; 10/2017
104-10163-10181; 3; 10/2017
104-10164-10012; 1; 10/2017
104-10164-10013; 2; 10/2017
104-10164-10019; 1; 10/2017
104-10164-10021; 4; 10/2017
104-10164-10022; 7; 10/2017
104-10164-10023; 1; 10/2017
104-10164-10025; 3; 10/2017
104-10164-10026; 2; 10/2017
104-10164-10028; 1; 10/2017
104-10164-10032; 1; 10/2017
104-10164-10033; 5; 10/2017
104-10164-10034; 5; 10/2017
104-10164-10035; 3; 10/2017
104-10164-10036; 9; 10/2017
104-10164-10043; 3; 10/2017
104-10164-10045; 2; 10/2017
104-10164-10046; 3; 10/2017
104-10164-10049; 1; 10/2017
104-10164-10051; 4; 10/2017
104-10164-10052; 1; 10/2017
104-10164-10057; 3; 10/2017
104-10164-10059; 1; 10/2017
104-10164-10067; 1; 10/2017
104-10164-10068; 9; 10/2017
104-10164-10069; 1; 10/2017
104-10164-10070; 9; 10/2017
104-10164-10071; 4; 10/2017
104-10164-10072; 6; 10/2017
104-10164-10073; 3; 10/2017
104-10164-10074; 3; 10/2017
104-10164-10075; 16; 10/2017
104-10164-10076; 5; 10/2017
104-10164-10077; 14; 10/2017
104-10164-10079; 1; 10/2017
104-10164-10080; 3; 10/2017
104-10164-10082; 2; 10/2017
104-10164-10084; 2; 10/2017
104-10164-10085; 2; 10/2017
104-10164-10086; 1; 10/2017
104-10164-10087; 6; 10/2017
104-10164-10088; 19; 10/2017
104-10164-10089; 1; 10/2017
104-10164-10090; 4; 10/2017
104-10164-10091; 2; 10/2017
104-10164-10092; 1; 10/2017
104-10164-10093; 3; 10/2017
104-10164-10094; 2; 10/2017
104-10164-10095; 1; 10/2017

104-10164-10096; 1; 10/2017
 104-10164-10114; 2; 10/2017
 104-10165-10001; 2; 10/2017
 104-10165-10002; 2; 10/2017
 104-10165-10003; 4; 10/2017
 104-10165-10004; 1; 10/2017
 104-10165-10005; 2; 10/2017
 104-10165-10006; 2; 10/2017
 104-10165-10008; 1; 10/2017
 104-10165-10009; 1; 10/2017
 104-10165-10010; 2; 10/2017
 104-10165-10011; 8; 10/2017
 104-10165-10012; 10; 10/2017
 104-10165-10013; 8; 10/2017
 104-10165-10014; 5; 10/2017
 104-10165-10015; 1; 10/2017
 104-10165-10016; 3; 10/2017
 104-10165-10017; 1; 10/2017
 104-10165-10021; 1; 10/2017
 104-10165-10026; 3; 10/2017
 104-10165-10027; 2; 10/2017
 104-10165-10028; 1; 10/2017
 104-10165-10029; 1; 10/2017
 104-10165-10030; 2; 10/2017
 104-10165-10031; 4; 10/2017
 104-10165-10032; 1; 10/2017
 104-10165-10034; 1; 10/2017
 104-10165-10035; 2; 10/2017
 104-10165-10036; 1; 10/2017
 104-10165-10037; 1; 10/2017
 104-10165-10038; 2; 10/2017
 104-10165-10039; 1; 10/2017
 104-10165-10040; 1; 10/2017
 104-10165-10041; 2; 10/2017
 104-10165-10044; 3; 10/2017
 104-10165-10045; 1; 10/2017
 104-10165-10046; 1; 10/2017
 104-10165-10049; 1; 10/2017
 104-10165-10050; 8; 10/2017
 104-10165-10051; 2; 10/2017
 104-10165-10052; 1; 10/2017
 104-10165-10053; 1; 10/2017
 104-10165-10054; 1; 10/2017
 104-10165-10055; 2; 10/2017
 104-10165-10056; 2; 10/2017
 104-10165-10057; 1; 10/2017
 104-10165-10058; 4; 10/2017
 104-10165-10059; 2; 10/2017
 104-10165-10060; 3; 10/2017
 104-10165-10061; 3; 10/2017
 104-10165-10062; 2; 10/2017
 104-10165-10063; 2; 10/2017
 104-10165-10064; 1; 10/2017
 104-10165-10066; 1; 10/2017
 104-10165-10067; 1; 10/2017
 104-10165-10068; 1; 10/2017
 104-10165-10069; 1; 10/2017
 104-10165-10070; 3; 10/2017
 104-10165-10071; 5; 10/2017
 104-10165-10072; 1; 10/2017
 104-10165-10073; 4; 10/2017
 104-10165-10074; 2; 10/2017
 104-10165-10088; 3; 10/2017
 104-10165-10089; 5; 10/2017
 104-10165-10090; 10; 10/2017
 104-10165-10091; 3; 10/2017
 104-10165-10095; 2; 10/2017
 104-10165-10096; 1; 10/2017
 104-10165-10097; 3; 10/2017
 104-10165-10099; 4; 10/2017
 104-10165-10100; 1; 10/2017
 104-10165-10101; 3; 10/2017
 104-10165-10102; 1; 10/2017
 104-10165-10103; 3; 10/2017
 104-10165-10105; 1; 10/2017
 104-10165-10107; 1; 10/2017
 104-10165-10109; 2; 10/2017
 104-10165-10110; 5; 10/2017
 104-10165-10111; 1; 10/2017
 104-10165-10112; 2; 10/2017
 104-10165-10113; 1; 10/2017
 104-10165-10114; 2; 10/2017
 104-10165-10115; 2; 10/2017
 104-10165-10116; 1; 10/2017
 104-10165-10117; 6; 10/2017
 104-10165-10118; 1; 10/2017
 104-10165-10122; 1; 10/2017
 104-10165-10129; 2; 10/2017
 104-10165-10131; 2; 10/2017
 104-10165-10135; 1; 10/2017
 104-10165-10136; 2; 10/2017
 104-10165-10138; 3; 10/2017
 104-10165-10142; 2; 10/2017
 104-10165-10145; 1; 10/2017
 104-10165-10146; 6; 10/2017
 104-10165-10147; 1; 10/2017
 104-10165-10148; 4; 10/2017
 104-10165-10149; 2; 10/2017
 104-10165-10150; 6; 10/2017
 104-10165-10151; 3; 10/2017
 104-10165-10152; 8; 10/2017
 104-10165-10153; 2; 10/2017
 104-10165-10154; 6; 10/2017
 104-10165-10155; 1; 10/2017
 104-10165-10156; 5; 10/2017
 104-10165-10157; 5; 10/2017
 104-10165-10158; 1; 10/2017
 104-10165-10159; 2; 10/2017
 104-10165-10160; 2; 10/2017
 104-10165-10161; 6; 10/2017
 104-10165-10162; 4; 10/2017
 104-10165-10163; 2; 10/2017
 104-10165-10164; 3; 10/2017
 104-10165-10165; 1; 10/2017
 104-10165-10166; 1; 10/2017
 104-10165-10167; 3; 10/2017
 104-10165-10168; 4; 10/2017
 104-10165-10169; 7; 10/2017
 104-10165-10171; 2; 10/2017
 104-10165-10172; 1; 10/2017
 104-10165-10174; 17; 10/2017
 104-10165-10175; 17; 10/2017
 104-10165-10177; 1; 10/2017
 104-10166-10005; 1; 10/2017
 104-10166-10007; 1; 10/2017
 104-10166-10009; 1; 10/2017
 104-10166-10011; 4; 10/2017
 104-10166-10013; 6; 10/2017
 104-10166-10016; 1; 10/2017
 104-10166-10021; 3; 10/2017
 104-10166-10022; 11; 10/2017
 104-10166-10023; 8; 10/2017
 104-10166-10024; 3; 10/2017
 104-10166-10025; 6; 10/2017
 104-10166-10026; 3; 10/2017
 104-10166-10027; 7; 10/2017
 104-10166-10028; 1; 10/2017
 104-10166-10029; 2; 10/2017
 104-10166-10030; 2; 10/2017
 104-10166-10031; 4; 10/2017
 104-10166-10032; 5; 10/2017
 104-10166-10033; 1; 10/2017
 104-10166-10034; 1; 10/2017
 104-10166-10035; 1; 10/2017
 104-10166-10036; 1; 10/2017
 104-10166-10037; 4; 10/2017
 104-10166-10038; 1; 10/2017
 104-10166-10039; 4; 10/2017
 104-10166-10041; 2; 10/2017
 104-10166-10042; 6; 10/2017
 104-10166-10043; 2; 10/2017
 104-10166-10044; 2; 10/2017
 104-10166-10045; 1; 10/2017
 104-10166-10046; 5; 10/2017
 104-10166-10047; 2; 10/2017
 104-10166-10067; 1; 10/2017
 104-10166-10068; 1; 10/2017
 104-10166-10073; 1; 10/2017
 104-10166-10074; 2; 10/2017
 104-10166-10075; 1; 10/2017
 104-10166-10078; 1; 10/2017
 104-10166-10079; 2; 10/2017
 104-10166-10080; 1; 10/2017
 104-10166-10081; 1; 10/2017
 104-10166-10082; 1; 10/2017
 104-10166-10083; 1; 10/2017
 104-10166-10085; 1; 10/2017
 104-10166-10086; 1; 10/2017
 104-10166-10116; 3; 10/2017
 104-10166-10119; 1; 10/2017
 104-10166-10122; 2; 10/2017
 104-10166-10123; 7; 10/2017
 104-10166-10124; 2; 10/2017
 104-10166-10126; 1; 10/2017
 104-10166-10128; 19; 10/2017
 104-10166-10129; 2; 10/2017
 104-10166-10130; 1; 10/2017
 104-10166-10131; 1; 10/2017
 104-10166-10132; 2; 10/2017
 104-10166-10134; 1; 10/2017
 FBI Documents: Open in Full
 124-10081-10359; 0; None
 124-10118-10022; 0; None
 124-10118-10023; 0; None
 124-10142-10418; 0; None
 124-10268-10387; 0; None
 124-10270-10007; 0; None
 124-10272-10371; 0; None
 124-10274-10295; 0; None
 FBI Documents: Postponed in Part
 124-10179-10129; 24; 10/2017
 124-10197-10000; 4; 10/2017
 124-10197-10001; 1; 10/2017
 124-10197-10003; 1; 10/2017
 124-10197-10008; 4; 10/2017
 124-10197-10009; 7; 10/2017
 124-10197-10010; 2; 10/2017
 124-10197-10016; 1; 10/2017
 124-10197-10017; 2; 10/2017
 124-10197-10019; 1; 10/2017
 124-10197-10026; 1; 10/2017
 124-10197-10030; 3; 10/2017
 124-10197-10042; 4; 10/2017
 124-10197-10044; 1; 10/2017
 124-10197-10046; 1; 10/2017
 124-10197-10056; 1; 10/2017
 124-10197-10058; 1; 10/2017
 124-10197-10082; 1; 10/2017
 124-10197-10086; 1; 10/2017
 124-10197-10359; 9; 10/2017
 124-10197-10360; 4; 10/2017
 124-10197-10364; 9; 10/2017
 124-10200-10428; 2; 10/2017
 124-10200-10431; 24; 10/2017
 124-10200-10435; 1; 10/2017
 124-10200-10436; 6; 10/2017
 124-10200-10439; 6; 10/2017
 124-10200-10442; 1; 10/2017
 124-10200-10443; 12; 10/2017
 124-10200-10444; 1; 10/2017
 124-10200-10445; 7; 10/2017
 124-10200-10446; 6; 10/2017
 124-10200-10447; 8; 10/2017
 124-10200-10449; 15; 10/2017
 124-10200-10450; 7; 10/2017
 124-10200-10455; 2; 10/2017
 124-10200-10456; 5; 10/2017

124-10200-10457; 1; 10/2017
124-10200-10468; 2; 10/2017
124-10200-10469; 2; 10/2017
124-10200-10470; 4; 10/2017
124-10200-10471; 3; 10/2017
124-10200-10474; 2; 10/2017
124-10200-10475; 2; 10/2017
124-10200-10476; 1; 10/2017
124-10200-10477; 1; 10/2017
124-10200-10478; 4; 10/2017
124-10200-10480; 2; 10/2017
124-10200-10483; 2; 10/2017
124-10200-10484; 2; 10/2017
124-10200-10485; 2; 10/2017
124-10201-10415; 12; 10/2017
124-10201-10416; 20; 10/2017
124-10201-10417; 4; 10/2017
124-10204-10341; 1; 10/2017
124-10204-10349; 10; 10/2017
124-10204-10353; 2; 10/2017
124-10204-10362; 3; 10/2017
124-10204-10363; 3; 10/2017
124-10204-10366; 13; 10/2017
124-10204-10368; 1; 10/2017
124-10204-10370; 91; 10/2017
124-10204-10386; 1; 10/2017
124-10204-10390; 2; 10/2017
124-10204-10391; 1; 10/2017
124-10204-10396; 3; 10/2017
124-10204-10403; 1; 10/2017
124-10204-10404; 2; 10/2017
124-10204-10412; 2; 10/2017
124-10204-10415; 1; 10/2017
124-10204-10417; 87; 10/2017
124-10204-10421; 1; 10/2017
124-10204-10425; 5; 10/2017
124-10204-10426; 18; 10/2017
124-10204-10429; 3; 10/2017
124-10204-10431; 3; 10/2017
124-10204-10432; 10; 10/2017
124-10204-10433; 4; 10/2017
124-10204-10434; 29; 10/2017
124-10205-10450; 17; 10/2017
124-10206-10406; 13; 10/2017
124-10206-10408; 102; 10/2017
124-10206-10413; 2; 10/2017
124-10206-10414; 7; 10/2017
124-10206-10415; 21; 10/2017
124-10206-10416; 8; 10/2017
124-10206-10455; 1; 10/2017
124-10206-10458; 207; 10/2017
124-10208-10403; 12; 10/2017
124-10208-10404; 2; 10/2017
124-10208-10405; 3; 10/2017
124-10208-10406; 1; 10/2017
124-10208-10407; 14; 10/2017
124-10208-10408; 14; 10/2017
124-10208-10410; 1; 10/2017
124-10208-10412; 3; 10/2017
124-10208-10413; 24; 10/2017
124-10208-10414; 9; 10/2017
124-10208-10415; 8; 10/2017
124-10208-10418; 4; 10/2017
124-10208-10419; 2; 10/2017
124-10208-10421; 7; 10/2017
124-10208-10422; 2; 10/2017
124-10209-10469; 9; 10/2017
124-10209-10475; 1; 10/2017
124-10209-10476; 1; 10/2017
124-10211-10246; 70; 10/2017
124-10211-10247; 8; 10/2017
124-10211-10290; 1; 10/2017
124-10211-10300; 21; 10/2017
124-10211-10305; 2; 10/2017
124-10211-10308; 20; 10/2017
124-10211-10423; 1; 10/2017
124-10211-10431; 8; 10/2017
124-10211-10454; 68; 10/2017
124-10212-10393; 19; 10/2017
124-10212-10402; 8; 10/2017
124-10212-10403; 24; 10/2017
124-10212-10410; 6; 10/2017
124-10212-10428; 2; 10/2017
124-10212-10429; 2; 10/2017
124-10212-10430; 5; 10/2017
124-10212-10431; 15; 10/2017
124-10212-10432; 9; 10/2017
124-10212-10433; 6; 10/2017
124-10212-10434; 5; 10/2017
124-10213-10429; 3; 10/2017
124-10213-10435; 2; 10/2017
124-10213-10436; 4; 10/2017
124-10213-10438; 1; 10/2017
124-10213-10439; 1; 10/2017
124-10213-10440; 1; 10/2017
124-10213-10444; 3; 10/2017
124-10213-10445; 2; 10/2017
124-10213-10447; 86; 10/2017
124-10213-10458; 7; 10/2017
124-10213-10461; 1; 10/2017
124-10213-10464; 20; 10/2017
124-10213-10465; 4; 10/2017
124-10213-10479; 2; 10/2017
124-10213-10484; 10; 10/2017
124-10213-10485; 1; 10/2017
124-10213-10487; 10; 10/2017
124-10213-10488; 19; 10/2017
124-10213-10492; 5; 10/2017
124-10213-10494; 3; 10/2017
124-10213-10497; 7; 10/2017
124-10213-10498; 7; 10/2017
124-10214-10029; 2; 10/2017
124-10214-10031; 10; 10/2017
124-10215-10225; 4; 10/2017
124-10215-10230; 1; 10/2017
124-10215-10235; 12; 10/2017
124-10215-10236; 2; 10/2017
124-10215-10238; 1; 10/2017
124-10215-10251; 2; 10/2017
124-10215-10254; 26; 10/2017
124-10215-10260; 9; 10/2017
124-10215-10276; 12; 10/2017
124-10215-10284; 1; 10/2017
124-10215-10287; 1; 10/2017
124-10215-10288; 2; 10/2017
124-10215-10299; 25; 10/2017
124-10215-10300; 2; 10/2017
124-10215-10307; 3; 10/2017
124-10215-10316; 4; 10/2017
124-10216-10235; 120; 10/2017
124-10216-10236; 4; 10/2017
124-10216-10237; 13; 10/2017
124-10216-10238; 8; 10/2017
124-10216-10239; 8; 10/2017
124-10216-10240; 7; 10/2017
124-10216-10241; 12; 10/2017
124-10216-10396; 5; 10/2017
124-10216-10400; 17; 10/2017
124-10216-10406; 1; 10/2017
124-10216-10407; 7; 10/2017
124-10216-10408; 9; 10/2017
124-10216-10411; 14; 10/2017
124-10216-10422; 4; 10/2017
124-10216-10428; 2; 10/2017
124-10216-10429; 2; 10/2017
124-10216-10430; 1; 10/2017
124-10216-10431; 1; 10/2017
124-10216-10432; 4; 10/2017
124-10216-10434; 2; 10/2017
124-10216-10435; 2; 10/2017
124-10216-10436; 2; 10/2017
124-10216-10437; 2; 10/2017
124-10216-10438; 1; 10/2017
124-10216-10439; 2; 10/2017
124-10216-10440; 4; 10/2017
124-10216-10443; 4; 10/2017
124-10216-10444; 2; 10/2017
124-10216-10445; 2; 10/2017
124-10216-10446; 2; 10/2017
124-10216-10448; 2; 10/2017
124-10216-10449; 3; 10/2017
124-10216-10451; 2; 10/2017
124-10216-10452; 1; 10/2017
124-10216-10454; 2; 10/2017
124-10216-10455; 1; 10/2017
124-10216-10459; 3; 10/2017
124-10216-10461; 3; 10/2017
124-10216-10463; 2; 10/2017
124-10216-10465; 2; 10/2017
124-10216-10466; 1; 10/2017
124-10216-10467; 3; 10/2017
124-10216-10469; 4; 10/2017
124-10216-10470; 2; 10/2017
124-10216-10471; 13; 10/2017
124-10216-10472; 4; 10/2017
124-10216-10474; 26; 10/2017
124-10216-10475; 2; 10/2017
124-10216-10476; 1; 10/2017
124-10216-10477; 2; 10/2017
124-10216-10478; 2; 10/2017
124-10216-10479; 1; 10/2017
124-10216-10480; 2; 10/2017
124-10216-10481; 2; 10/2017
124-10216-10482; 2; 10/2017
124-10216-10483; 2; 10/2017
124-10216-10484; 2; 10/2017
124-10216-10485; 4; 10/2017
124-10216-10486; 2; 10/2017
124-10216-10487; 2; 10/2017
124-10216-10488; 2; 10/2017
124-10216-10490; 2; 10/2017
124-10216-10491; 2; 10/2017
124-10216-10493; 4; 10/2017
124-10216-10494; 2; 10/2017
124-10216-10495; 2; 10/2017
124-10216-10496; 2; 10/2017
124-10217-10095; 12; 10/2017
124-10217-10096; 6; 10/2017
124-10217-10097; 6; 10/2017
124-10217-10098; 6; 10/2017
124-10217-10099; 11; 10/2017
124-10217-10100; 4; 10/2017
124-10217-10102; 11; 10/2017
124-10217-10103; 9; 10/2017
124-10217-10105; 9; 10/2017
124-10217-10107; 9; 10/2017
124-10217-10109; 4; 10/2017
124-10217-10110; 2; 10/2017
124-10217-10114; 4; 10/2017
124-10217-10116; 1; 10/2017
124-10217-10118; 13; 10/2017
124-10217-10120; 62; 10/2017
124-10217-10122; 9; 10/2017
124-10217-10133; 2; 10/2017
124-10217-10137; 3; 10/2017
124-10217-10140; 14; 10/2017
124-10217-10143; 3; 10/2017
124-10217-10150; 5; 10/2017
124-10217-10152; 1; 10/2017
124-10217-10153; 18; 10/2017
124-10217-10162; 2; 10/2017
124-10217-10170; 3; 10/2017
124-10217-10173; 11; 10/2017
124-10217-10174; 34; 10/2017
124-10217-10175; 4; 10/2017
124-10217-10176; 5; 10/2017
124-10217-10177; 8; 10/2017
124-10217-10182; 12; 10/2017

124-10217-10185; 13; 10/2017
124-10217-10190; 15; 10/2017
124-10217-10195; 10; 10/2017
124-10217-10263; 11; 10/2017
124-10219-10213; 1; 10/2017
124-10219-10214; 2; 10/2017
124-10219-10216; 1; 10/2017
124-10219-10218; 9; 10/2017
124-10219-10220; 9; 10/2017
124-10219-10222; 6; 10/2017
124-10219-10229; 3; 10/2017
124-10219-10234; 6; 10/2017
124-10219-10237; 13; 10/2017
124-10219-10240; 5; 10/2017
124-10219-10241; 2; 10/2017
124-10219-10242; 6; 10/2017
124-10219-10243; 2; 10/2017
124-10219-10244; 11; 10/2017
124-10219-10245; 25; 10/2017
124-10219-10250; 7; 10/2017
124-10219-10251; 3; 10/2017
124-10219-10252; 7; 10/2017
124-10219-10253; 1; 10/2017
124-10219-10254; 1; 10/2017
124-10219-10255; 8; 10/2017
124-10220-10070; 5; 10/2017
124-10220-10075; 2; 10/2017
124-10220-10103; 4; 10/2017
124-10220-10110; 3; 10/2017
124-10220-10115; 2; 10/2017
124-10220-10205; 1; 10/2017
124-10220-10225; 1; 10/2017
124-10220-10291; 16; 10/2017
124-10220-10296; 15; 10/2017
124-10220-10299; 1; 10/2017
124-10220-10301; 9; 10/2017
124-10220-10303; 1; 10/2017
124-10220-10444; 28; 10/2017
124-10220-10491; 104; 10/2017
124-10220-10495; 13; 10/2017
124-10221-10065; 12; 10/2017
124-10221-10066; 12; 10/2017
124-10221-10071; 5; 10/2017
124-10221-10072; 12; 10/2017
124-10221-10076; 3; 10/2017
124-10221-10078; 8; 10/2017
124-10222-10041; 1; 10/2017
124-10222-10046; 1; 10/2017
124-10222-10048; 17; 10/2017
124-10222-10052; 4; 10/2017
124-10222-10053; 2; 10/2017
124-10222-10055; 3; 10/2017
124-10222-10087; 1; 10/2017
124-10222-10093; 3; 10/2017
124-10222-10108; 1; 10/2017
124-10222-10476; 1; 10/2017
124-10223-10319; 8; 10/2017
124-10223-10323; 1; 10/2017
124-10223-10330; 6; 10/2017
124-10223-10339; 2; 10/2017
124-10223-10340; 11; 10/2017
124-10223-10344; 4; 10/2017
124-10223-10348; 4; 10/2017
124-10223-10349; 5; 10/2017
124-10223-10351; 2; 10/2017
124-10223-10353; 2; 10/2017
124-10223-10354; 4; 10/2017
124-10223-10362; 13; 10/2017
124-10223-10363; 1; 10/2017
124-10223-10365; 4; 10/2017
124-10223-10366; 1; 10/2017
124-10223-10367; 1; 10/2017
124-10223-10373; 1; 10/2017
124-10223-10374; 2; 10/2017
124-10223-10375; 1; 10/2017
124-10223-10382; 1; 10/2017
124-10223-10386; 5; 10/2017
124-10223-10397; 5; 10/2017
124-10223-10412; 1; 10/2017
124-10223-10414; 6; 10/2017
124-10223-10429; 2; 10/2017
124-10223-10430; 1; 10/2017
124-10223-10431; 10; 10/2017
124-10223-10433; 1; 10/2017
124-10223-10436; 4; 10/2017
124-10223-10439; 1; 10/2017
124-10223-10443; 1; 10/2017
124-10223-10444; 21; 10/2017
124-10223-10445; 14; 10/2017
124-10223-10446; 3; 10/2017
124-10223-10447; 1; 10/2017
124-10223-10448; 4; 10/2017
124-10223-10449; 3; 10/2017
124-10223-10451; 3; 10/2017
124-10223-10456; 4; 10/2017
124-10223-10458; 13; 10/2017
124-10223-10459; 1; 10/2017
124-10223-10460; 2; 10/2017
124-10223-10461; 6; 10/2017
124-10223-10466; 5; 10/2017
124-10223-10469; 11; 10/2017
124-10224-10030; 6; 10/2017
124-10224-10031; 23; 10/2017
124-10226-10141; 1; 10/2017
124-10226-10148; 5; 10/2017
124-10226-10149; 2; 10/2017
124-10226-10151; 2; 10/2017
124-10226-10156; 42; 10/2017
124-10226-10157; 5; 10/2017
124-10226-10159; 8; 10/2017
124-10226-10161; 12; 10/2017
124-10226-10164; 17; 10/2017
124-10226-10166; 5; 10/2017
124-10226-10175; 5; 10/2017
124-10226-10173; 4; 10/2017
124-10226-10174; 3; 10/2017
124-10226-10175; 7; 10/2017
124-10226-10176; 2; 10/2017
124-10226-10181; 2; 10/2017
124-10226-10182; 1; 10/2017
124-10226-10184; 10; 10/2017
124-10226-10185; 7; 10/2017
124-10226-10186; 12; 10/2017
124-10226-10187; 7; 10/2017
124-10226-10188; 3; 10/2017
124-10226-10189; 1; 10/2017
124-10226-10190; 2; 10/2017
124-10226-10191; 6; 10/2017
124-10226-10192; 3; 10/2017
124-10250-10233; 18; 10/2017
124-10251-10249; 18; 10/2017
124-10277-10288; 4; 10/2017
124-10277-10289; 4; 10/2017
124-10277-10291; 2; 10/2017
124-10277-10293; 10; 10/2017
124-10277-10294; 1; 10/2017
124-10277-10297; 10; 10/2017
124-10277-10298; 12; 10/2017
124-10277-10299; 10; 10/2017
124-10277-10300; 3; 10/2017
124-10277-10302; 18; 10/2017
124-10277-10303; 5; 10/2017
124-10277-10304; 9; 10/2017
124-10277-10305; 5; 10/2017
124-10278-10081; 3; 10/2017
124-10278-10086; 8; 10/2017
124-10278-10094; 3; 10/2017
124-10278-10097; 1; 10/2017
124-10278-10105; 11; 10/2017
124-10278-10118; 1; 10/2017
124-10278-10120; 3; 10/2017
124-10278-10124; 2; 10/2017
124-10278-10126; 1; 10/2017
124-10278-10128; 65; 10/2017
124-10278-10218; 1; 10/2017
124-10278-10221; 5; 10/2017
124-10278-10229; 6; 10/2017
124-10278-10231; 12; 10/2017
124-10278-10253; 2; 10/2017
124-10278-10264; 4; 10/2017
124-10278-10271; 15; 10/2017
124-10278-10282; 1; 10/2017
124-10278-10284; 7; 10/2017
124-10278-10285; 2; 10/2017
124-10278-10312; 3; 10/2017
124-10278-10319; 3; 10/2017
124-10278-10321; 3; 10/2017
124-10278-10322; 4; 10/2017
124-10278-10324; 1; 10/2017
124-10278-10326; 14; 10/2017
124-10278-10328; 6; 10/2017
124-10278-10331; 5; 10/2017
124-10278-10340; 209; 10/2017
124-10278-10347; 14; 10/2017
124-10278-10356; 2; 10/2017
124-10278-10365; 59; 10/2017
124-10278-10370; 1; 10/2017
124-10278-10376; 1; 10/2017
124-10278-10377; 4; 10/2017
124-10279-10119; 4; 10/2017
124-10279-10144; 9; 10/2017
124-10280-10119; 2; 10/2017
124-10280-10127; 18; 10/2017
124-10282-10001; 1; 10/2017
124-10282-10002; 1; 10/2017
124-10282-10003; 4; 10/2017
124-10282-10005; 2; 10/2017
124-10282-10007; 2; 10/2017
124-10282-10008; 4; 10/2017
124-10282-10010; 2; 10/2017
124-10282-10011; 3; 10/2017
124-10282-10013; 2; 10/2017
124-10282-10014; 1; 10/2017
124-10282-10015; 3; 10/2017
124-10282-10016; 2; 10/2017
124-10282-10019; 3; 10/2017
124-10282-10021; 3; 10/2017
124-10282-10027; 2; 10/2017
124-10282-10029; 3; 10/2017
124-10282-10030; 12; 10/2017
124-10282-10031; 1; 10/2017
124-10282-10032; 3; 10/2017
124-10282-10033; 2; 10/2017
124-10282-10035; 4; 10/2017
124-10282-10036; 2; 10/2017
124-10282-10037; 5; 10/2017
124-10282-10038; 26; 10/2017
124-10282-10040; 2; 10/2017
124-10282-10041; 1; 10/2017
124-10282-10042; 2; 10/2017
124-10282-10043; 2; 10/2017
124-10282-10044; 2; 10/2017
124-10282-10045; 2; 10/2017
124-10282-10046; 1; 10/2017
124-10282-10047; 2; 10/2017
124-10282-10048; 2; 10/2017
124-10282-10049; 2; 10/2017
124-10282-10050; 4; 10/2017
124-10282-10051; 2; 10/2017
124-10282-10052; 4; 10/2017
124-10282-10054; 2; 10/2017
124-10282-10055; 2; 10/2017
124-10282-10056; 2; 10/2017
124-10282-10058; 4; 10/2017
124-10282-10059; 2; 10/2017
124-10282-10060; 2; 10/2017
124-10282-10061; 2; 10/2017
124-10282-10064; 1; 10/2017

124-10282-10066; 2; 10/2017
 124-10282-10067; 2; 10/2017
 124-10282-10068; 3; 10/2017
 124-10282-10072; 1; 10/2017
 124-10282-10074; 1; 10/2017
 124-10282-10076; 2; 10/2017
 124-10282-10078; 1; 10/2017
 124-10282-10080; 1; 10/2017
 124-10282-10085; 1; 10/2017
 124-10282-10161; 1; 10/2017
 124-10282-10165; 31; 10/2017
 124-10282-10166; 25; 10/2017
 124-10282-10167; 34; 10/2017
 124-10282-10168; 79; 10/2017
 124-10282-10170; 45; 10/2017
 124-10282-10174; 10; 10/2017
 124-10282-10175; 2; 10/2017
 124-10282-10179; 3; 10/2017
 124-10282-10188; 4; 10/2017
 124-10282-10191; 55; 10/2017
 124-10282-10192; 1; 10/2017
 124-10282-10194; 3; 10/2017
 124-10282-10195; 1; 10/2017
 124-10282-10197; 18; 10/2017
 124-10282-10205; 41; 10/2017
 124-10282-10206; 2; 10/2017
 124-10282-10209; 29; 10/2017
 124-10282-10212; 1; 10/2017
 124-10282-10213; 1; 10/2017
 124-10282-10214; 37; 10/2017
 124-10282-10215; 9; 10/2017
 124-10282-10216; 23; 10/2017
 124-10282-10219; 29; 10/2017
 124-10282-10220; 2; 10/2017
 124-10282-10221; 8; 10/2017
 124-10282-10222; 1; 10/2017
 124-10282-10223; 15; 10/2017
 124-10282-10224; 6; 10/2017
 124-10282-10227; 12; 10/2017
 124-10283-10009; 3; 10/2017
 124-10283-10044; 8; 10/2017
 124-10283-10054; 4; 10/2017
 124-10283-10057; 18; 10/2017
 124-10283-10061; 5; 10/2017
 124-10283-10062; 303; 10/2017
 124-10283-10064; 7; 10/2017
 124-10283-10065; 7; 10/2017
 124-10283-10066; 3; 10/2017
 124-10283-10069; 24; 10/2017
 124-10283-10081; 4; 10/2017
 124-10283-10084; 8; 10/2017
 124-10283-10088; 45; 10/2017
 124-10283-10093; 2; 10/2017
 124-10283-10095; 6; 10/2017
 124-10283-10096; 38; 10/2017
 124-10283-10137; 1; 10/2017
 124-10283-10138; 1; 10/2017
 124-10283-10139; 5; 10/2017
 124-10283-10141; 6; 10/2017
 124-10283-10142; 8; 10/2017
 124-10283-10144; 6; 10/2017
 124-10283-10145; 10; 10/2017
 124-10283-10146; 1; 10/2017
 124-10283-10147; 3; 10/2017
 124-10283-10148; 77; 10/2017
 124-10283-10149; 3; 10/2017
 124-10283-10150; 9; 10/2017
 124-10283-10151; 3; 10/2017
 124-10283-10153; 1; 10/2017
 124-10283-10156; 1; 10/2017
 124-10283-10157; 108; 10/2017
 124-10283-10158; 3; 10/2017
 124-10283-10159; 2; 10/2017
 124-10283-10160; 1; 10/2017
 124-10283-10164; 109; 10/2017
 124-10283-10166; 1; 10/2017
 124-10283-10167; 1; 10/2017
 124-10283-10171; 1; 10/2017
 124-10283-10173; 11; 10/2017
 124-10283-10176; 1; 10/2017
 124-10283-10177; 1; 10/2017
 124-10283-10178; 1; 10/2017
 124-10283-10182; 1; 10/2017
 124-10283-10188; 2; 10/2017
 124-10283-10193; 17; 10/2017
 124-10283-10194; 17; 10/2017
 124-10283-10196; 2; 10/2017
 124-10283-10197; 1; 10/2017
 124-10283-10199; 4; 10/2017
 124-10283-10200; 26; 10/2017
 124-10283-10203; 2; 10/2017
 124-10283-10205; 7; 10/2017
 124-10283-10207; 26; 10/2017
 124-10283-10208; 2; 10/2017
 124-10283-10210; 6; 10/2017
 124-10283-10214; 1; 10/2017
 124-10283-10215; 1; 10/2017
 124-10284-10020; 45; 10/2017
 124-10284-10028; 105; 10/2017
 124-10284-10029; 4; 10/2017
 124-10284-10030; 20; 10/2017
 124-10284-10032; 3; 10/2017
 124-10284-10033; 24; 10/2017
 124-10284-10037; 7; 10/2017
 124-10284-10040; 5; 10/2017
 124-10284-10041; 4; 10/2017
 124-10284-10042; 5; 10/2017
 124-10284-10213; 5; 10/2017
 124-10284-10215; 16; 10/2017
 124-10284-10217; 1; 10/2017
 124-10284-10220; 1; 10/2017
 124-10284-10225; 8; 10/2017
 124-10284-10227; 2; 10/2017
 124-10284-10229; 1; 10/2017
 124-10284-10236; 6; 10/2017
 124-10284-10241; 1; 10/2017
 124-10284-10246; 9; 10/2017
 124-10284-10254; 1; 10/2017
 124-10284-10265; 1; 10/2017
 124-10284-10267; 1; 10/2017
 124-10284-10268; 9; 10/2017
 124-10284-10269; 2; 10/2017
 124-10284-10270; 27; 10/2017
 124-10284-10274; 5; 10/2017
 124-10284-10276; 19; 10/2017
 124-10284-10280; 6; 10/2017
 124-10284-10401; 4; 10/2017
 124-10284-10402; 66; 10/2017
 124-10284-10403; 37; 10/2017
 124-10284-10406; 17; 10/2017
 124-10284-10428; 3; 10/2017
 124-10284-10431; 3; 10/2017
 124-10284-10439; 1; 10/2017
 124-10284-10454; 4; 10/2017
 124-10284-10457; 8; 10/2017
 124-10285-10174; 4; 10/2017
 124-10286-10002; 1; 10/2017
 124-10286-10004; 1; 10/2017
 124-10286-10005; 2; 10/2017
 124-10286-10008; 3; 10/2017
 124-10286-10011; 12; 10/2017
 124-10286-10015; 7; 10/2017
 124-10286-10018; 7; 10/2017
 124-10286-10022; 4; 10/2017
 124-10286-10023; 10; 10/2017
 124-10286-10025; 1; 10/2017
 124-10286-10027; 6; 10/2017
 124-10286-10029; 1; 10/2017
 124-10286-10030; 7; 10/2017
 124-10286-10031; 25; 10/2017
 124-10286-10032; 7; 10/2017
 124-10286-10033; 2; 10/2017
 124-10286-10039; 9; 10/2017
 124-10286-10070; 1; 10/2017
 124-10286-10072; 17; 10/2017
 124-10286-10077; 1; 10/2017
 124-10286-10078; 2; 10/2017
 124-10286-10291; 2; 10/2017
 124-10286-10293; 9; 10/2017
 124-10286-10295; 13; 10/2017
 124-10286-10296; 13; 10/2017
 124-10286-10298; 75; 10/2017
 124-10286-10299; 7; 10/2017
 124-10286-10304; 2; 10/2017
 124-10286-10308; 1; 10/2017
 124-10286-10312; 13; 10/2017
 124-10286-10326; 10; 10/2017
 124-10286-10331; 12; 10/2017
 124-10286-10334; 1; 10/2017
 124-10286-10337; 13; 10/2017
 124-10286-10338; 1; 10/2017
 124-10286-10339; 1; 10/2017
 124-10286-10340; 103; 10/2017
 124-10286-10343; 9; 10/2017
 124-10286-10344; 4; 10/2017
 124-10286-10345; 4; 10/2017
 124-10286-10347; 17; 10/2017
 124-10286-10350; 3; 10/2017
 124-10286-10351; 67; 10/2017
 124-10286-10353; 2; 10/2017
 124-10286-10354; 13; 10/2017
 124-10286-10357; 7; 10/2017
 124-10286-10362; 20; 10/2017
 124-10286-10364; 1; 10/2017
 124-10286-10367; 41; 10/2017
 124-10286-10368; 1; 10/2017
 124-10286-10369; 2; 10/2017
 124-10286-10370; 2; 10/2017
 124-10286-10371; 6; 10/2017
 124-10286-10373; 3; 10/2017
 124-10286-10374; 3; 10/2017
 124-10286-10383; 4; 10/2017
 124-10286-10385; 58; 10/2017
 124-10286-10470; 1; 10/2017
 124-10286-10471; 2; 10/2017
 124-10286-10474; 1; 10/2017
 124-10286-10476; 1; 10/2017
 124-10286-10477; 1; 10/2017
 124-10286-10480; 1; 10/2017
 124-10286-10484; 2; 10/2017
 124-10286-10489; 16; 10/2017
 124-10286-10493; 58; 10/2017
 124-10286-10499; 3; 10/2017
 124-10287-10000; 2; 10/2017
 124-10287-10001; 3; 10/2017
 124-10287-10004; 2; 10/2017
 124-10287-10005; 1; 10/2017
 124-10287-10007; 2; 10/2017
 124-10287-10009; 1; 10/2017
 124-10287-10014; 5; 10/2017
 124-10287-10034; 6; 10/2017
 124-10287-10040; 3; 10/2017
 124-10287-10044; 77; 10/2017
 124-10287-10155; 5; 10/2017
 124-10287-10171; 2; 10/2017
 124-10287-10188; 4; 10/2017
 124-10287-10189; 8; 10/2017
 124-10287-10190; 1; 10/2017
 124-10287-10191; 1; 10/2017
 124-10287-10192; 61; 10/2017
 124-10287-10195; 21; 10/2017
 124-10287-10196; 5; 10/2017
 124-10287-10197; 1; 10/2017
 124-10287-10198; 1; 10/2017
 124-10287-10204; 4; 10/2017
 124-10287-10205; 6; 10/2017
 124-10287-10206; 20; 10/2017
 124-10287-10207; 20; 10/2017

124-10287-10208; 3; 10/2017
124-10287-10209; 153; 10/2017
124-10287-10210; 43; 10/2017
124-10287-10212; 100; 10/2017
124-10287-10213; 31; 10/2017
124-10287-10218; 46; 10/2017
124-10287-10219; 1; 10/2017
124-10287-10221; 1; 10/2017
124-10287-10228; 8; 10/2017
124-10287-10234; 3; 10/2017
124-10287-10239; 7; 10/2017
124-10287-10240; 1; 10/2017
124-10287-10241; 24; 10/2017
124-10287-10242; 20; 10/2017
124-10287-10243; 7; 10/2017
124-10287-10245; 2; 10/2017
124-10287-10340; 1; 10/2017
124-10287-10341; 8; 10/2017
124-10287-10343; 2; 10/2017
124-10287-10350; 1; 10/2017
124-10287-10353; 3; 10/2017
124-10287-10354; 2; 10/2017
124-10287-10356; 8; 10/2017
124-10287-10357; 4; 10/2017
124-10287-10359; 1; 10/2017
124-10287-10360; 1; 10/2017
124-10287-10368; 1; 10/2017
124-10287-10377; 16; 10/2017
124-10287-10378; 34; 10/2017
124-10287-10379; 17; 10/2017
124-10287-10380; 14; 10/2017
124-10287-10383; 16; 10/2017
124-10287-10387; 2; 10/2017
124-10287-10391; 3; 10/2017
124-10287-10392; 2; 10/2017
124-10287-10393; 11; 10/2017
124-10287-10395; 1; 10/2017
124-10288-10416; 10; 10/2017
124-10288-10417; 5; 10/2017
124-10288-10418; 12; 10/2017
124-10288-10419; 9; 10/2017
124-10288-10420; 4; 10/2017
124-10288-10422; 5; 10/2017
124-10288-10423; 1; 10/2017
124-10288-10425; 2; 10/2017
124-10288-10426; 3; 10/2017
124-10288-10427; 2; 10/2017
124-10288-10431; 1; 10/2017
124-10288-10432; 2; 10/2017
124-10288-10435; 1; 10/2017
124-10288-10435; 1; 10/2017
124-10288-10436; 5; 10/2017
124-10288-10437; 1; 10/2017
124-10288-10438; 3; 10/2017
124-10288-10439; 1; 10/2017
124-10288-10440; 1; 10/2017
124-10288-10441; 1; 10/2017
124-10288-10443; 1; 10/2017
124-10288-10444; 5; 10/2017
124-10288-10445; 7; 10/2017
124-10288-10448; 1; 10/2017
124-10288-10449; 1; 10/2017
124-10288-10450; 4; 10/2017
124-10288-10451; 4; 10/2017
124-10288-10452; 5; 10/2017
124-10288-10454; 1; 10/2017
124-10288-10458; 3; 10/2017
124-10288-10459; 7; 10/2017
124-10288-10463; 2; 10/2017
124-10288-10464; 3; 10/2017
124-10288-10465; 2; 10/2017
124-10288-10468; 1; 10/2017
124-10288-10469; 6; 10/2017
124-10288-10475; 7; 10/2017
124-10288-10479; 2; 10/2017
124-10288-10484; 10; 10/2017
124-10288-10490; 2; 10/2017
124-10288-10491; 2; 10/2017
124-10288-10493; 6; 10/2017
124-10288-10495; 7; 10/2017
124-10288-10496; 1; 10/2017
124-10288-10498; 4; 10/2017
124-10289-10185; 3; 10/2017
124-10289-10186; 4; 10/2017
124-10289-10187; 1; 10/2017
124-10289-10188; 2; 10/2017
124-10289-10190; 4; 10/2017
124-10289-10191; 1; 10/2017
124-10289-10192; 8; 10/2017
124-10289-10193; 4; 10/2017
124-10289-10194; 19; 10/2017
124-10289-10195; 1; 10/2017
124-10289-10197; 1; 10/2017
124-10289-10198; 6; 10/2017
124-10289-10200; 1; 10/2017
124-10289-10201; 5; 10/2017
124-10289-10202; 2; 10/2017
124-10289-10205; 7; 10/2017
124-10289-10206; 2; 10/2017
124-10289-10209; 2; 10/2017
124-10289-10210; 1; 10/2017
124-10289-10211; 2; 10/2017
124-10289-10212; 1; 10/2017
124-10289-10216; 14; 10/2017
124-10289-10220; 3; 10/2017
124-10289-10222; 5; 10/2017
124-10289-10223; 3; 10/2017
124-10289-10224; 3; 10/2017
124-10289-10225; 4; 10/2017
124-10289-10226; 1; 10/2017
124-10289-10228; 6; 10/2017
124-10289-10229; 2; 10/2017
124-10289-10230; 6; 10/2017
124-10289-10231; 1; 10/2017
124-10289-10233; 1; 10/2017
124-10289-10235; 6; 10/2017
124-10289-10236; 4; 10/2017
124-10289-10237; 1; 10/2017
124-10289-10238; 2; 10/2017
124-10289-10240; 9; 10/2017
124-10289-10241; 4; 10/2017
124-10289-10243; 2; 10/2017
124-10289-10245; 2; 10/2017
124-10289-10250; 1; 10/2017
124-10289-10251; 1; 10/2017
124-10289-10254; 9; 10/2017
124-10289-10256; 3; 10/2017
124-10289-10259; 1; 10/2017
124-10289-10260; 1; 10/2017
124-10289-10261; 1; 10/2017
124-10289-10262; 1; 10/2017
124-10289-10263; 2; 10/2017
124-10289-10265; 4; 10/2017
124-10289-10266; 1; 10/2017
124-10289-10272; 2; 10/2017
124-10289-10274; 2; 10/2017
124-10289-10276; 3; 10/2017
124-10289-10278; 1; 10/2017
124-10289-10279; 4; 10/2017
124-10289-10281; 1; 10/2017
124-10289-10283; 6; 10/2017
124-10289-10291; 2; 10/2017
124-10289-10292; 1; 10/2017
124-10289-10296; 2; 10/2017
124-10289-10311; 6; 10/2017
124-10289-10320; 2; 10/2017
124-10289-10322; 4; 10/2017
124-10289-10325; 2; 10/2017
124-10289-10333; 5; 10/2017
124-10289-10334; 2; 10/2017
124-10290-10005; 3; 10/2017
124-10290-10020; 1; 10/2017
124-10290-10021; 7; 10/2017
124-10290-10027; 2; 10/2017
124-10290-10029; 16; 10/2017
124-10290-10030; 4; 10/2017
124-10290-10032; 1; 10/2017
124-10290-10166; 1; 10/2017
124-10290-10168; 2; 10/2017
124-10290-10346; 3; 10/2017
124-10290-10347; 3; 10/2017
124-10290-10349; 1; 10/2017
124-10290-10351; 1; 10/2017
124-10290-10356; 3; 10/2017
124-10290-10357; 2; 10/2017
124-10290-10361; 1; 10/2017
124-10290-10367; 14; 10/2017
124-10290-10368; 1; 10/2017
124-10290-10374; 1; 10/2017
124-10290-10375; 5; 10/2017
124-10290-10379; 93; 10/2017
124-10290-10381; 13; 10/2017
124-10290-10382; 10; 10/2017
124-10290-10384; 6; 10/2017
124-10290-10388; 1; 10/2017
124-10290-10391; 2; 10/2017
124-10290-10393; 5; 10/2017
124-10290-10394; 6; 10/2017
124-10290-10396; 2; 10/2017
124-10290-10397; 4; 10/2017
124-10290-10398; 1; 10/2017
124-10290-10399; 1; 10/2017
124-10290-10401; 2; 10/2017
124-10290-10402; 1; 10/2017
124-10290-10403; 1; 10/2017
124-10290-10404; 1; 10/2017
124-10290-10405; 3; 10/2017
124-10290-10406; 3; 10/2017
124-10290-10408; 9; 10/2017
124-10290-10409; 10; 10/2017
124-10290-10454; 1; 10/2017
124-10290-10456; 2; 10/2017
124-10290-10457; 2; 10/2017
124-10290-10458; 9; 10/2017
124-10290-10459; 1; 10/2017
124-10290-10460; 3; 10/2017
124-10290-10464; 1; 10/2017
124-10290-10470; 2; 10/2017
124-10290-10474; 3; 10/2017
124-10290-10475; 2; 10/2017
124-10290-10476; 5; 10/2017
124-10290-10477; 1; 10/2017
124-10290-10478; 3; 10/2017
124-10290-10479; 1; 10/2017
124-10290-10483; 1; 10/2017
124-10290-10484; 15; 10/2017
124-10290-10485; 1; 10/2017
124-10290-10488; 1; 10/2017
124-10290-10489; 3; 10/2017
124-10290-10490; 2; 10/2017
124-10290-10491; 1; 10/2017
124-10290-10492; 7; 10/2017
124-10290-10493; 1; 10/2017
124-10290-10494; 1; 10/2017
124-10290-10495; 2; 10/2017
124-10290-10496; 6; 10/2017
124-10290-10497; 5; 10/2017
124-10290-10498; 40; 10/2017
124-10290-10499; 1; 10/2017
124-10291-10287; 1; 10/2017
124-10292-10091; 3; 10/2017
124-10292-10093; 3; 10/2017
124-10292-10096; 2; 10/2017
124-10292-10097; 7; 10/2017
124-10292-10100; 5; 10/2017
124-10292-10105; 3; 10/2017

124-10292-10111; 5; 10/2017
 124-10292-10117; 9; 10/2017
 124-10292-10118; 16; 10/2017
 124-10292-10131; 4; 10/2017
 124-10292-10140; 7; 10/2017
 124-10292-10143; 2; 10/2017
 124-10293-10227; 4; 10/2017
 124-10293-10229; 6; 10/2017
 124-10293-10230; 3; 10/2017
 124-10293-10235; 1; 10/2017
 124-10293-10237; 1; 10/2017
 124-10293-10239; 1; 10/2017
 124-10293-10240; 2; 10/2017
 124-10293-10241; 2; 10/2017
 124-10293-10242; 5; 10/2017
 124-10293-10243; 1; 10/2017
 124-10293-10244; 2; 10/2017
 124-10293-10245; 1; 10/2017
 124-10293-10247; 1; 10/2017
 124-10293-10248; 1; 10/2017
 124-10293-10249; 1; 10/2017
 124-10293-10257; 3; 10/2017
 124-10293-10259; 5; 10/2017
 124-10293-10260; 3; 10/2017
 124-10293-10261; 9; 10/2017
 124-10293-10262; 3; 10/2017
 124-10293-10263; 19; 10/2017
 124-10293-10264; 1; 10/2017
 124-10293-10265; 3; 10/2017
 124-10293-10267; 3; 10/2017
 124-10293-10268; 1; 10/2017
 124-10293-10269; 1; 10/2017
 124-10293-10270; 1; 10/2017
 124-10293-10271; 5; 10/2017
 124-10293-10273; 1; 10/2017
 124-10293-10274; 9; 10/2017
 124-10293-10279; 11; 10/2017
 124-10293-10281; 5; 10/2017
 124-10293-10290; 2; 10/2017
 124-10293-10293; 10; 10/2017
 124-10293-10295; 2; 10/2017
 124-10293-10296; 4; 10/2017
 124-10293-10297; 7; 10/2017
 124-10293-10298; 8; 10/2017
 124-10293-10299; 2; 10/2017
 124-10293-10300; 15; 10/2017
 124-10293-10301; 3; 10/2017
 124-10293-10302; 3; 10/2017
 124-10293-10303; 212; 10/2017
 124-10293-10304; 4; 10/2017
 124-10293-10305; 5; 10/2017
 124-10293-10307; 2; 10/2017
 124-10293-10310; 7; 10/2017
 124-10293-10311; 4; 10/2017
 124-10293-10312; 18; 10/2017
 124-10293-10313; 2; 10/2017
 124-10293-10314; 3; 10/2017
 124-10293-10315; 7; 10/2017
 124-10293-10316; 7; 10/2017
 124-10293-10318; 2; 10/2017
 124-10293-10323; 2; 10/2017
 124-10293-10324; 1; 10/2017
 124-10293-10325; 2; 10/2017
 124-10293-10328; 11; 10/2017
 124-10293-10329; 6; 10/2017
 124-10293-10330; 7; 10/2017
 124-10293-10331; 4; 10/2017
 124-10293-10332; 7; 10/2017
 124-10293-10333; 3; 10/2017
 124-10293-10334; 2; 10/2017
 124-10293-10335; 5; 10/2017
 124-10293-10336; 10; 10/2017
 124-10293-10337; 8; 10/2017
 124-10293-10338; 26; 10/2017
 124-10293-10339; 39; 10/2017
 124-10293-10341; 23; 10/2017

124-10293-10343; 7; 10/2017
 124-10293-10345; 29; 10/2017
 124-10293-10347; 6; 10/2017
 124-10293-10348; 1; 10/2017
 124-10293-10349; 17; 10/2017
 124-10293-10350; 13; 10/2017
 124-10293-10351; 22; 10/2017
 124-10293-10352; 4; 10/2017
 124-10294-10151; 1; 10/2017
 124-10294-10152; 2; 10/2017
 124-10294-10186; 1; 10/2017
 124-10297-10001; 7; 10/2017
 124-10297-10002; 2; 10/2017
 124-10297-10003; 49; 10/2017
 124-10297-10005; 1; 10/2017
 124-10297-10008; 2; 10/2017
 124-10297-10011; 1; 10/2017
 124-10297-10016; 14; 10/2017
 124-10297-10017; 1; 10/2017
 124-10297-10021; 5; 10/2017
 124-10297-10023; 1; 10/2017
 124-10297-10031; 3; 10/2017
 124-10297-10033; 3; 10/2017
 124-10297-10038; 5; 10/2017
 124-10297-10040; 1; 10/2017
 124-10297-10041; 20; 10/2017
 124-10297-10042; 4; 10/2017
 124-10297-10044; 2; 10/2017
 124-10297-10054; 4; 10/2017
 124-10297-10059; 3; 10/2017
 124-10297-10065; 3; 10/2017
 124-10297-10077; 2; 10/2017
 124-10297-10078; 13; 10/2017
 124-10297-10082; 7; 10/2017
 124-10297-10086; 4; 10/2017
 124-10297-10094; 1; 10/2017
 124-10297-10098; 6; 10/2017
 124-10297-10099; 1; 10/2017
 124-10297-10107; 4; 10/2017
 124-10297-10108; 27; 10/2017
 124-10297-10111; 17; 10/2017
 124-10297-10112; 15; 10/2017
 124-10297-10113; 35; 10/2017
 124-10297-10114; 2; 10/2017
 124-10297-10119; 8; 10/2017
 124-10297-10120; 17; 10/2017
 124-10297-10124; 5; 10/2017
 124-10297-10126; 7; 10/2017
 124-10297-10128; 26; 10/2017
 124-10297-10129; 13; 10/2017
 124-10297-10130; 8; 10/2017
 124-10297-10132; 69; 10/2017
 124-10297-10133; 31; 10/2017
 124-10297-10134; 8; 10/2017
 124-10302-10000; 7; 10/2017
 124-10302-10005; 8; 10/2017
 124-10302-10006; 1; 10/2017
 124-10302-10007; 5; 10/2017
 124-10302-10009; 2; 10/2017
 124-10302-10011; 2; 10/2017
 124-10302-10134; 3; 10/2017
 124-10302-10137; 6; 10/2017
 124-10302-10143; 3; 10/2017
 124-10302-10145; 16; 10/2017
 124-10302-10160; 3; 10/2017
 124-10302-10172; 3; 10/2017
 124-10302-10210; 27; 10/2017
 124-10302-10212; 1; 10/2017
 124-10302-10231; 3; 10/2017
 124-10302-10240; 7; 10/2017
 124-10302-10241; 14; 10/2017
 124-10302-10243; 1; 10/2017
 124-10302-10244; 77; 10/2017
 124-10302-10247; 9; 10/2017
 124-10302-10253; 1; 10/2017
 124-10302-10258; 1; 10/2017

124-10302-10260; 1; 10/2017
 124-10312-10053; 4; 10/2017
 124-90022-10004; 8; 10/2017
 124-90022-10005; 1; 10/2017
 124-90022-10006; 3; 10/2017
 124-90022-10009; 3; 10/2017
 124-90022-10013; 1; 10/2017
 124-90022-10014; 1; 10/2017
 124-90022-10016; 1; 10/2017
 124-90022-10019; 4; 10/2017
 124-90022-10020; 2; 10/2017
 124-90022-10021; 2; 10/2017
 124-90022-10023; 2; 10/2017
 124-90022-10024; 1; 10/2017
 124-90022-10025; 1; 10/2017
 124-90022-10030; 1; 10/2017
 124-90022-10032; 2; 10/2017

HSCA Documents: Postponed in Part

180-10141-10222; 2; 05/2001
 180-10142-10167; 1; 10/2017
 180-10143-10153; 8; 10/2017

NARA-LBJ Documents: Postponed in Part

177-10001-10296; 1; 10/2017
 177-10001-10437; 3; 10/2017
 177-10001-10466; 1; 10/2017
 177-10001-10473; 7; 10/2017
 177-10002-10022; 3; 10/2017
 177-10002-10025; 1; 10/2017
 177-10002-10069; 1; 10/2017
 177-10002-10070; 1; 10/2017
 177-10002-10072; 1; 10/2017

State Department Documents: Postponed in Part

119-10003-10059; 1; 10/2017
 119-10003-10076; 3; 10/2017
 119-10003-10077; 3; 10/2017
 119-10003-10230; 1; 10/2017
 119-10017-10228; 5; 10/2017
 119-10021-10413; 10; 10/2017

NSA Documents: Postponed in Part

144-10001-10127; 30; 10/2017
 144-10001-10153; 4; 10/2017
 144-10001-10158; 19; 10/2017
 144-10001-10159; 15; 10/2017
 144-10001-10164; 11; 10/2017
 144-10001-10169; 11; 10/2017
 144-10001-10170; 7; 10/2017
 144-10001-10172; 12; 10/2017
 144-10001-10173; 2; 10/2017
 144-10001-10174; 19; 10/2017
 144-10001-10193; 6; 10/2017
 144-10001-10200; 7; 10/2017
 144-10001-10202; 41; 10/2017
 144-10001-10203; 9; 10/2017
 144-10001-10206; 14; 10/2017
 144-10001-10210; 6; 10/2017
 144-10001-10263; 1; 10/2017
 144-10001-10264; 140; 10/2017
 144-10001-10269; 9; 10/2017

Notice of Additional Releases

After consultation with appropriate Federal agencies, the Review Board announces that the following Federal Bureau of Investigation records are now being opened in full:

124-00219-10207; 124-10197-10002; 124-10197-10004; 124-10197-10005; 124-10197-10006; 124-10197-10007; 124-10197-10011; 124-10197-10012; 124-10197-10013; 124-10197-10014; 124-10197-10015; 124-10197-10018; 124-

10297-10104; 124-10297-10105; 124-10297-10106; 124-10297-10109; 124-10297-10110; 124-10297-10115; 124-10297-10116; 124-10297-10117; 124-10297-10118; 124-10297-10127; 124-10297-10135; 124-10297-10136; 124-10297-10137; 124-10297-10138; 124-10298-10012; 124-10298-10134; 124-10298-10135; 124-10298-10139; 124-10298-10147; 124-10298-10148; 124-10299-10000; 124-10299-10001; 124-10299-10002; 124-10299-10003; 124-10300-10057; 124-10302-10001; 124-10302-10002; 124-10302-10003; 124-10302-10004; 124-10302-10008; 124-10302-10010; 124-10302-10012; 124-10302-10130; 124-10302-10131; 124-10302-10135; 124-10302-10136; 124-10302-10139; 124-10302-10140; 124-10302-10144; 124-10302-10147; 124-10302-10150; 124-10302-10153; 124-10302-10155; 124-10302-10162; 124-10302-10164; 124-10302-10165; 124-10302-10168; 124-10302-10170; 124-10302-10174; 124-10302-10176; 124-10302-10183; 124-10302-10220; 124-10302-10222; 124-10302-10224; 124-10302-10232; 124-10302-10234; 124-10302-10235; 124-10302-10236; 124-10302-10237; 124-10302-10238; 124-10302-10239; 124-10302-10242; 124-10302-10246; 124-10302-10248; 124-10302-10249; 124-10302-10250; 124-10302-10251; 124-10302-10252; 124-10302-10255; 124-10302-10256; 124-10302-10257; 124-10302-10259; 124-10302-10261; 124-10302-10262; 124-10302-10263; 124-10302-10264; 124-10302-10268; 124-10302-10274; 124-10312-10000; 124-10312-10001; 124-10312-10002; 124-10312-10003; 124-10312-10004; 124-10312-10005; 124-10312-10006; 124-10312-10007; 124-10312-10008; 124-10312-10009; 124-10312-10010; 124-10312-10011; 124-10312-10012; 124-10312-10013; 124-10312-10014; 124-10312-10015; 124-10312-10016; 124-10312-10017; 124-10312-10018; 124-10312-10019; 124-10312-10020; 124-10312-10021; 124-10312-10022; 124-10312-10023; 124-10312-10024; 124-10312-10025; 124-10312-10026; 124-10312-10027; 124-10312-10028; 124-10312-10029; 124-10312-10030; 124-10312-10031; 124-10312-10032; 124-10312-10033; 124-10312-10034; 124-10312-10035; 124-10312-10036; 124-10312-10037; 124-10312-10038; 124-10312-10039; 124-10312-10040; 124-10312-10041; 124-10312-10042; 124-10312-10043; 124-10312-10044; 124-10312-10045; 124-10312-10046; 124-10312-10047; 124-10312-10048; 124-10312-10049; 124-10312-10050; 124-10312-10051; 124-10312-10052; 124-10312-10054; 124-10312-10055; 124-10312-10056; 124-10312-10057; 124-10312-10059; 124-10312-10060; 124-10312-10061; 124-10312-10062; 124-10312-10063; 124-10312-10064; 124-10312-10065; 124-10312-10066; 124-10312-10067; 124-10312-10068; 124-10312-10069; 124-10312-10070; 124-10387-10342; 124-10387-10347; 124-10387-10394; 124-10397-10014; 124-11226-10180; 124-

90022-10007; 124-90022-10008; 124-90022-10010; 124-90022-10011; 124-90022-10012; 124-90022-10015; 124-90022-10017; 124-90022-10018; 124-90022-10022; 124-90022-10026; 124-90022-10027

After consultation with appropriate Federal agencies, the Review Board announces that the following House Select Committee on Assassinations records are now being opened in full:

180-10103-10423; 180-10106-10154; 180-10107-10486; 180-10107-10490; 180-10109-10273; 180-10140-10461; 180-10140-10472; 180-10140-10487; 180-10140-10492; 180-10141-10017; 180-10141-10056; 180-10141-10059; 180-10141-10087; 180-10141-10095; 180-10141-10096; 180-10141-10097; 180-10141-10098; 180-10141-10099; 180-10141-10100; 180-10141-10101; 180-10141-10102; 180-10141-10103; 180-10141-10104; 180-10141-10105; 180-10141-10111; 180-10141-10127; 180-10141-10128; 180-10141-10142; 180-10141-10144; 180-10141-10145; 180-10141-10148; 180-10141-10149; 180-10141-10155; 180-10141-10156; 180-10141-10158; 180-10141-10159; 180-10141-10162; 180-10141-10163; 180-10141-10166; 180-10141-10167; 180-10141-10169; 180-10141-10170; 180-10141-10181; 180-10141-10182; 180-10141-10184; 180-10141-10189; 180-10141-10193; 180-10141-10195; 180-10141-10197; 180-10141-10203; 180-10141-10206; 180-10141-10207; 180-10141-10208; 180-10141-10209; 180-10141-10216; 180-10141-10217; 180-10141-10226; 180-10141-10241; 180-10141-10242; 180-10141-10243; 180-10141-10250; 180-10141-10251; 180-10141-10252; 180-10141-10253; 180-10141-10262; 180-10141-10274; 180-10141-10277; 180-10141-10283; 180-10141-10284; 180-10141-10285; 180-10141-10286; 180-10141-10288; 180-10141-10289; 180-10141-10290; 180-10141-10292; 180-10141-10293; 180-10141-10345; 180-10141-10356; 180-10141-10358; 180-10141-10360; 180-10141-10374; 180-10141-10375; 180-10141-10376; 180-10141-10385; 180-10141-10396; 180-10141-10398; 180-10141-10401; 180-10141-10415; 180-10141-10418; 180-10141-10420; 180-10141-10422; 180-10141-10425; 180-10141-10426; 180-10141-10430; 180-10141-10432; 180-10141-10438; 180-10141-10445; 180-10141-10446; 180-10141-10448; 180-10141-10459; 180-10141-10462; 180-10141-10463; 180-10141-10465; 180-10141-10466; 180-10141-10468; 180-10141-10470; 180-10141-10471; 180-10141-10474; 180-10141-10475; 180-10141-10477; 180-10141-10482; 180-10141-10496; 180-10142-10011; 180-10142-10014; 180-10142-10020; 180-10142-10021; 180-10142-10022; 180-10142-10027; 180-10142-10039; 180-10142-10041; 180-10142-10043; 180-10142-10044; 180-10142-10050; 180-10142-10067; 180-10142-10072; 180-10142-10090; 180-10142-10095; 180-10142-10107; 180-

10142-10108; 180-10142-10109; 180-10142-10121; 180-10142-10123; 180-10142-10124; 180-10142-10131; 180-10142-10134; 180-10142-10138; 180-10142-10141; 180-10142-10143; 180-10142-10145; 180-10142-10147; 180-10142-10148; 180-10142-10149; 180-10142-10150; 180-10142-10151; 180-10142-10152; 180-10142-10153; 180-10142-10161; 180-10142-10173; 180-10142-10176; 180-10142-10181; 180-10142-10191; 180-10142-10197; 180-10142-10198; 180-10142-10215; 180-10142-10216; 180-10142-10217; 180-10142-10219; 180-10142-10222; 180-10142-10225; 180-10142-10226; 180-10142-10227; 180-10142-10235; 180-10142-10236; 180-10142-10243; 180-10142-10244; 180-10142-10245; 180-10142-10246; 180-10142-10248; 180-10142-10254; 180-10142-10255; 180-10142-10256; 180-10142-10278; 180-10142-10297; 180-10142-10298; 180-10142-10299; 180-10142-10306; 180-10142-10332; 180-10142-10337; 180-10142-10339; 180-10142-10340; 180-10142-10341; 180-10142-10369; 180-10142-10370; 180-10142-10372; 180-10142-10376; 180-10142-10383; 180-10142-10384; 180-10142-10387; 180-10142-10395; 180-10142-10398; 180-10142-10410; 180-10142-10412; 180-10142-10416; 180-10142-10417; 180-10142-10497; 180-10142-10499; 180-10143-10078; 180-10143-10079; 180-10143-10084; 180-10143-10086; 180-10143-10087; 180-10143-10097; 180-10143-10108; 180-10143-10117; 180-10143-10118; 180-10143-10119; 180-10143-10128; 180-10143-10130; 180-10143-10132; 180-10143-10136; 180-10143-10137; 180-10143-10143; 180-10143-10147; 180-10143-10154; 180-10143-10159; 180-10143-10165; 180-10143-10166; 180-10143-10169; 180-10143-10172; 180-10143-10174; 180-10143-10175; 180-10143-10178; 180-10143-10189; 180-10143-10196; 180-10143-10197; 180-10143-10200; 180-10143-10202; 180-10143-10205; 180-10143-10209; 180-10143-10210; 180-10143-10214; 180-10143-10218; 180-10143-10219; 180-10143-10228; 180-10143-10231; 180-10143-10232; 180-10143-10239; 180-10143-10240; 180-10143-10247; 180-10143-10250; 180-10143-10253; 180-10143-10255; 180-10143-10259; 180-10143-10267; 180-10143-10281; 180-10143-10291; 180-10143-10293; 180-10143-10295; 180-10143-10333; 180-10143-10337; 180-10143-10346; 180-10143-10347; 180-10143-10351; 180-10143-10354; 180-10143-10358; 180-10143-10363; 180-10143-10366; 180-10143-10385; 180-10143-10396; 180-10143-10405; 180-10143-10407; 180-10143-10408; 180-10143-10410; 180-10143-10417; 180-10143-10426; 180-10143-10427; 180-10143-10430; 180-10143-10432; 180-10143-10433; 180-10143-10450; 180-10143-10453; 180-10143-10454; 180-10143-10458; 180-10143-10459; 180-10143-10482; 180-10144-10008; 180-10144-10016; 180-10144-10021; 180-

10144-10214; 180-10144-10215; 180-10144-10216; 180-10144-10224; 180-10144-10228; 180-10144-10230; 180-10144-10231; 180-10144-10233; 180-10144-10234; 180-10144-10243; 180-10144-10252; 180-10144-10253; 180-10144-10254

After consultation with appropriate Federal agencies, the Review Board announces that the following State Department records are now being opened in full:

119-10001-10489; 119-10001-10496; 119-10003-10033; 119-10003-10063; 119-10003-10064; 119-10003-10078; 119-10003-10079; 119-10003-10080; 119-10003-10081; 119-10003-10082; 119-10003-10083; 119-10003-10084; 119-10003-10085; 119-10003-10086; 119-10003-10087; 119-10003-10088; 119-10003-10089; 119-10003-10090; 119-10003-10091; 119-10003-10092; 119-10003-10093; 119-10003-10094; 119-10003-10095; 119-10003-10096; 119-10003-10097; 119-10003-10098; 119-10003-10099; 119-10003-10100; 119-10003-10101; 119-10003-10102; 119-10003-10103; 119-10003-10104; 119-10003-10105; 119-10003-10106; 119-10003-10107; 119-10003-10108; 119-10003-10109; 119-10003-10113; 119-10003-10114; 119-10003-10115; 119-10003-10233; 119-10017-10105; 119-10021-10324; 119-10021-10352; 119-10021-10374; 119-10021-10378; 119-10021-10437; 119-10021-10443; 119-10021-10447; 119-10021-10495; 119-10022-10053; 119-10022-10054; 119-10022-10057; 119-10022-10070; 119-10022-10092; 119-10022-10094; 119-10022-10129; 119-10022-10137

After consultation with appropriate Federal agencies, the Review Board announces that the following Johnson Library records are now being opened in full:

177-10001-10065; 177-10001-10111; 177-10001-10162; 177-10001-10187; 177-10001-10214; 177-10001-10272; 177-10001-10275; 177-10001-10301; 177-10001-10302; 177-10001-10303; 177-10001-10304; 177-10001-10306; 177-10001-10308; 177-10001-10309; 177-10001-10320; 177-10001-10321; 177-10001-10322; 177-10001-10326; 177-10001-10328; 177-10001-10329; 177-10001-10330; 177-10001-10331; 177-10001-10332; 177-10001-10333; 177-10001-10334; 177-10001-10335; 177-10001-10336; 177-10001-10337; 177-10001-10338; 177-10001-10339; 177-10001-10340; 177-10001-10341; 177-10001-10342; 177-10001-10348; 177-10001-10350; 177-10001-10352; 177-10001-10353; 177-10001-10354; 177-10001-10355; 177-10001-10362; 177-10001-10367; 177-10001-10368; 177-10001-10383; 177-10001-10387; 177-10001-10388; 177-10001-10389; 177-10001-10390; 177-10001-10391; 177-10001-10393; 177-10001-10394; 177-10001-10396; 177-10001-10401; 177-10001-10404; 177-10001-10407; 177-

10001-10408; 177-10001-10409; 177-10001-10410; 177-10001-10411; 177-10001-10412; 177-10001-10413; 177-10001-10414; 177-10001-10415; 177-10001-10416; 177-10001-10417; 177-10001-10418; 177-10001-10419; 177-10001-10420; 177-10001-10421; 177-10001-10422; 177-10001-10423; 177-10001-10424; 177-10001-10425; 177-10001-10426; 177-10001-10427; 177-10001-10428; 177-10001-10429; 177-10001-10430; 177-10001-10431; 177-10001-10432; 177-10001-10434; 177-10001-10435; 177-10001-10436; 177-10001-10439; 177-10001-10440; 177-10001-10441; 177-10001-10447; 177-10001-10448; 177-10001-10449; 177-10001-10450; 177-10001-10451; 177-10001-10458; 177-10001-10459; 177-10001-10460; 177-10001-10462; 177-10001-10469; 177-10001-10470; 177-10001-10471; 177-10001-10474; 177-10001-10476; 177-10001-10478; 177-10001-10481; 177-10001-10482; 177-10001-10483; 177-10001-10484; 177-10001-10485; 177-10001-10486; 177-10001-10487; 177-10001-10488; 177-10001-10489; 177-10001-10491; 177-10001-10492; 177-10001-10493; 177-10001-10494; 177-10001-10495; 177-10001-10496; 177-10001-10498; 177-10002-10001; 177-10002-10002; 177-10002-10003; 177-10002-10004; 177-10002-10005; 177-10002-10006; 177-10002-10008; 177-10002-10023; 177-10002-10027; 177-10002-10039; 177-10002-10040; 177-10002-10042; 177-10002-10043; 177-10002-10044; 177-10002-10045; 177-10002-10046; 177-10002-10047; 177-10002-10048; 177-10002-10049; 177-10002-10050; 177-10002-10051; 177-10002-10052; 177-10002-10053; 177-10002-10055; 177-10002-10056; 177-10002-10061; 177-10002-10062; 177-10002-10063; 177-10002-10064; 177-10002-10067; 177-10002-10068; 177-10002-10073; 177-10002-10077; 177-10002-10078; 177-10002-10080; 177-10002-10081; 177-10002-10085

Notice of Assassination Records Designation

Designation: On January 22, 1998, the Assassination Records Review Board designated the following United States Secret Service materials as assassination records: records relating to Robert Bouck, Chief of the Protective Research Section (49 pages); White House detail records (110 pages); and the Protective Intelligence files of William Somerset [CO2-43860] (67 pages) and Joseph Milteer [CO2-35588] (97 pages).

Dated: February 2, 1998.

T. Jeremy Gunn,

Executive Director.

[FR Doc. 98-3267 Filed 2-9-98; 8:45 am]

BILLING CODE 6118-01-P

DEPARTMENT OF COMMERCE

Bureau of the Census

Annual Retail Trade Survey

ACTION: Proposed collection; comment request.

SUMMARY: The Department of Commerce, as part of its continuing effort to reduce paperwork and respondent burden, invites the general public and other Federal agencies to take this opportunity to comment on proposed and/or continuing information collections, as required by the Paperwork Reduction Act of 1995, Public Law 104-13 (44 U.S.C. 3506(c)(2)(A)).

DATES: Written comments must be submitted on or before April 13, 1998.

ADDRESSES: Direct all written comments to Linda Engelmeier, Departmental Forms Clearance Officer, Department of Commerce, Room 5327, 14th and Constitution Avenue, NW, Washington, DC 20230.

FOR FURTHER INFORMATION CONTACT: Requests for additional information or copies of the information collection instrument(s) and instructions should be directed to: Ronald L. Piencykoski, Bureau of the Census, Room 2626-FOB 3, Washington, D.C. 20233-6500, (301) 457-2713.

SUPPLEMENTARY INFORMATION:

I. Abstract

The Annual Retail Trade Survey (ARTS) provides a sound statistical basis for the formation of policy by other government agencies. It provides continuing and timely national statistics on retail trade augmenting the period between economic censuses, and is a continuation of similar retail trade surveys conducted each year since 1951 (except 1954). The data that the Bureau collects with the ARTS, annual sales, purchases, end-of-year inventories, and accounts receivables are applicable to a variety of public and business needs. The ARTS sample consists of all firms operating retail establishments within the U.S. whose probability of selection is determined by sales size that were used in the Monthly Retail Trade Survey (MRTS). An additional panel of cases, used only in the annual survey, are also canvassed. Estimates developed in the ARTS are used to benchmark the monthly sales and inventories series and the firms canvassed in this survey are not required to maintain additional records since carefully prepared estimates are acceptable if book figures are not available.

II. Method of Collection

We will collect this information by mail, FAX and telephone follow-up.

III. Data

OMB Number: 0607-0013.

Form Number: B-151, B-151A, B-151D, B-153, and B-153D.

Type of Review: Regular submission.

Affected Public: Retail businesses.

Estimated Number of Respondents: 23,700.

Estimated Time Per Response: .4142 hrs. (about 25 minutes).

Estimated Total Annual Burden Hours: 9,817 hours.

Estimated Total Annual Cost: The cost to the respondent is estimated to be \$134,002, based on an annual response burden of 9,817 hours and a rate of \$13.65 per hour to complete the form.

Respondent's Obligation: Mandatory.

Legal Authority: Title 13, United States Code, Sections 182, 224, and 225.

IV. Request for Comments

Comments are invited on: (a) Whether the proposed collection of information is necessary for the proper performance of the functions of the agency, including whether the information shall have practical utility; (b) the accuracy of the agency's estimate of the burden (including hours and cost) of the proposed collection of information; (c) ways to enhance the quality, utility, and clarity of the information to be collected; and (d) ways to minimize the burden of the collection of information on respondents, including through the use of automated collection techniques or other forms of information technology.

Comments submitted in response to this notice will be summarized and/or included in the request for OMB approval of this information collection; they also will become a matter of public record.

Dated: February 5, 1998.

Linda Engelmeier,

Departmental Forms Clearance Officer, Office of Management and Organization.

[FR Doc. 98-3306 Filed 2-9-98; 8:45 am]

BILLING CODE 3510-07-P

DEPARTMENT OF COMMERCE**Proposed Agency Information Collection Activities**

BUREAU: International Trade Administration, Technology and Aerospace Industries, Office of Telecommunications.

TITLE: NATO International Competitive Bidding (ICB) Bidders List Application.

ACTION: Proposed collection; comment request.

SUMMARY: The Department of Commerce, as part of its continuing effort to reduce paperwork and respondent burden, invites the general public and other Federal agencies to take this opportunity to comment on the continuing information collections, as required by the Paperwork Reduction Act of 1995, Public Law 104-13 (44 U.S.C. 3506)(c)(2)(A)).

DATES: Written comments must be submitted by April 13, 1998.

ADDRESSES: Direct all written comments to Linda Engelmeier, Departmental Forms Clearance Officer, Department of Commerce, Room 5327, 14th & Constitution Avenue, NW, Washington, DC 20230. Phone number (202) 482-3272.

FOR FURTHER INFORMATION CONTACT: Requests for additional information or copies of the information collection instrument and instructions should be directed to: Alexis Kemper, Office of Telecommunications, Room 4323, Department of Commerce, 14th & Constitution Avenue, NW, Washington, DC 20230; phone (202) 482-1512, fax (202) 482-5834.

SUPPLEMENTARY INFORMATION:**I. Abstract**

Opportunities to bid for contracts under the NATO Security Investment Program (NSIP) are only open to firms of member NATO countries. NSIP procedures for international competitive bidding (AC/4-D/2261) require that each NATO country certify that their respective firms are eligible to bid such contracts. This is done through the issuance of a "Declaration of Eligibility." The U.S. Department of Commerce/ITA is the executive agency responsible for certifying U.S. firms. ITA-4023P is the application form used by USDOC/ITA to collect information needed to ascertain the eligibility of a U.S. firm. ITA reviews the application for completeness and accuracy and determines a company's eligibility based on its financial viability, technical capability, and security clearances with the Department of Defense.

II. Method of Collection

The Department of Commerce distributes Form ITA-4023P to potential applicants upon request. The applicant completes the form and then forwards it to the U.S. Department of Commerce/Office of Telecommunications for processing.

III. Data

OMB Number: 0625-0055.

Form Number: ITA-4023P.

Type of Review: Regular submission.

Affected Public: Business or other for-profit.

Estimated Number of Respondents: 60.

Estimated Time per Response: 1 hour.

Estimated Total Annual Burden

Hours: 60 hours.

Estimated Total Annual Cost: \$1,000.

IV. Requested for Comments

Comments are invited on: (a) Whether the proposed collection of information is necessary for the proper performance of the functions of the agency, including whether the information shall have practical utility; (b) the accuracy of the agency's estimate of the burden (including hours and cost) of the proposed collection of information; (c) ways to enhance the quality, utility, and clarity of the information to be collected; and (d) ways to minimize the burden of the collection of information on respondents, including through the use of automated collection techniques or other forms of information technology.

Comments submitted in response to this notice will be summarized and/or included in the request for OMB approval of this information collection; they also will become a matter of public record.

Dated: February 5, 1998.

Linda Engelmeier,

Departmental Forms Clearance Officer, Office of Management and Organization.

[FR Doc. 98-3305 Filed 2-9-98; 8:45 am]

BILLING CODE 3510-DR-P

DEPARTMENT OF COMMERCE**International Trade Administration**

[A-821-803 and A-834-803]

Titanium Sponge From the Russian Federation and Republic of Kazakhstan: Postponement of Preliminary Results of Antidumping Duty Administrative Reviews

AGENCY: Import Administration, International Trade Administration, Department of Commerce.

ACTION: Extension of time limits for preliminary results of antidumping duty administrative reviews.

SUMMARY: The Department of Commerce is extending by 60 days the time limit of the preliminary results of the antidumping duty administrative review of the antidumping finding on titanium sponge from the Russian Federation (A-821-803) and the Republic of Kazakhstan (A-834-803), covering the period

August 1, 1996, through July 31, 1997, since it is not practicable to complete these reviews within the time limits mandated by the Tariff Act of 1930, as amended (19 U.S.C. 1675(a)(3)(A)).

EFFECTIVE DATE: February 10, 1998.

FOR FURTHER INFORMATION CONTACT:

Mark Manning or Laurel LaCivita, Antidumping Duty and Countervailing Duty Enforcement, Office Four, Import Administration, International Trade Administration, U.S. Department of Commerce, 14th Street and Constitution Avenue, N.W., Washington, DC 20230; telephone (202) 482-3936 and 482-4740, respectively.

SUPPLEMENTARY INFORMATION:

Applicable Statute

Unless otherwise indicated, all citations to the statute are references to the provisions effective January 1, 1995, the effective date of the amendments made to the Tariff Act of 1930 (the Act) by the Uruguay Round Agreements Act. In addition, unless otherwise indicated, all citations to the Department of Commerce's regulations are to the current regulations as codified at 19 CFR 351.

Background

On September 25, 1997 (62 FR 50292), the Department of Commerce (the Department) initiated an administrative review of the antidumping findings on titanium sponge from the Russian Federation and the Republic of Kazakstan, covering the period August 1, 1996, through July 31, 1997. In our notice of initiation, we stated our intention to issue the final results of these reviews no later than August 31, 1998. Due to the complexity of the legal and methodological issues presented by these reviews, the Department has determined that it is not practicable to complete these reviews within the time limits mandated by the Tariff Act of 1930 (the Act), as amended (19 U.S.C. 1675(a)(3)(A)).

Postponement of Preliminary and Final Results of Review

Section 751(a)(3)(A) of the Act requires the Department to make a preliminary determination within 245 days after the last day of the anniversary month of an order/finding for which a review is requested and a final determination within 120 days after the date on which the preliminary determination is published. However, if it is not practicable to complete the review within the time period, section 751(a)(3)(A) allows the Department to extend this time period to a maximum of 365 days and 180 days, respectively.

We determine that it is not practicable to complete these reviews within the original time frame because of the complexity of the legal and methodological issues in these reviews.

Due to the 60 day extension, the deadline for issuing the preliminary results of these reviews is now no later than July 3, 1998. The deadline for issuing the final results of these reviews will be no later than 120 days from the publication of the preliminary results.

These extensions are in accordance with section 751(a)(3)(A) of the Act (19 U.S.C. 1675(a)(3)(A)).

Dated: February 4, 1998.

Richard Moreland,

Acting Deputy Assistant Secretary for Import Administration.

[FR Doc. 98-3335 Filed 2-9-98; 8:45 am]

BILLING CODE 3510-DS-P

DEPARTMENT OF COMMERCE

International Trade Administration

Notice of Scope Rulings

AGENCY: Import Administration, International Trade Administration, Department of Commerce.

ACTION: Notice of scope rulings and anticircumvention inquiries.

SUMMARY: The Department of Commerce hereby publishes a list of scope rulings and anticircumvention inquiries completed by Import Administration between October 1, 1997 and December 31, 1997. In conjunction with this list, the Department of Commerce is also publishing a list of pending requests for scope clarifications and anticircumvention inquiries. We intend to publish future lists within 30 days of the end of each quarter.

EFFECTIVE DATE: February 10, 1998.

FOR FURTHER INFORMATION CONTACT: Ronald M. Trentham, Import Administration, International Trade Administration, U.S. Department of Commerce, 14th Street and Constitution Avenue, NW, Washington, D.C. 20230; telephone: (202) 482-4793.

Background

The regulations of the Department of Commerce (the Department) (19 CFR 351.225(o)) provide that on a quarterly basis the Secretary will publish in the *Federal Register* a list of scope rulings completed within the last three months.

This notice lists scope rulings and anticircumvention inquiries completed by Import Administration, between October 1, 1997, and December 31, 1997, and pending scope clarification and anticircumvention inquiry requests.

The Department intends to publish in April 1998 a notice of scope rulings and anticircumvention inquiries completed between January 1, 1998, and March 31, 1998, as well as pending scope clarification and anticircumvention inquiry requests.

The following lists provide the country, case reference number, requester(s), and a brief description of either the ruling or product subject to the request.

I. SCOPE RULINGS COMPLETED BETWEEN OCTOBER 1, 1997 and DECEMBER 31, 1997

Country: Italy

A-475-818 *Certain Pasta*

C-475-819 Shonfeld's (U.S.A.) Inc.—Multicolored pasta in decorative glass containers, which are sealed with cork or paraffin and bound with raffia, is outside the scope of the order. 8/25/97.

Country: People's Republic of China

A-570-832 *Pure Magnesium*

American Metallurgical Inc. (AMI)—Magnesium crystal granules having a maximum dimension (i.e., length or diameter) of less than one inch are included within the scope of the order. 11/14/97.

A-570-504 *Petroleum Wax Candles*

Meijer, Inc.—Three candles (Joy, Peace, flame) are within the scope of the order. Two candles (Noel, Happy Valentine's Day) are outside the scope of the order. 12/15/97.

Country: Japan

A-588-703 *Internal-Combustion Industrial Forklift Trucks*

Nissan Motor Co., Ltd., and Nissan Forklift Corporation (collectively Nissan)—Model FO5-70 forklifts are not within the scope of the order. 10/14/97.

A-588-802 *3.5" Microdisks*

Maxell Corporation of America—Maxell's OSD325—Floptical Disk is outside the scope of the order. 11/21/97.

A-588-803 *Stainless Steel Bar*

Keystone Stainless Inc.—"Keystone 2000," a speciality stainless steel bar product, is within the scope of the order. 10/15/97.

II. ANTICIRCUMVENTION RULINGS COMPLETED BETWEEN OCTOBER 1, 1997 AND DECEMBER 31, 1997

None.

III. SCOPE INQUIRIES TERMINATED BETWEEN OCTOBER 1, 1997 AND DECEMBER 31, 1997

None.

IV. ANTICIRCUMVENTION INQUIRIES TERMINATED BETWEEN OCTOBER 1, 1997 AND DECEMBER 31, 1997

Country: Korea

A-580-008 *Color Television Receivers*

On August 11, 1995, the International Brotherhood of Electrical Workers, the International Union of Electronic, Electrical, Salaried, Machine & Furniture Workers, and the Industrial Union Department (collectively the petitioners), filed an application requesting that the Department conduct an anti-circumvention inquiry of the antidumping order on color televisions from the Republic of Korea. Pursuant to that application, the Department initiated an anti-circumvention inquiry on January 19, 1996. On December 19, 1997, petitioners submitted a letter requesting that the Department terminate the inquiry. Accordingly, the anticircumvention inquiry was terminated effective 12/31/97.

V. PENDING SCOPE CLARIFICATION REQUESTS AS OF DECEMBER 31, 1997

Country: Canada

A-122-823 *Certain Cut-to-Length Carbon Steel Plate*

Petitioners—Clarification to determine whether certain carbon steel plate with boron added is within the scope of the order.

Country: Sweden

A-401-040 *Stainless Steel Plate*

Avesta Sheffield AB and Avesta Sheffield NAD, Inc.—Clarification to determine whether stainless steel slabs that are manufactured in Great Britain and rolled into hot bands in Sweden are within the scope of the order.

Country: Germany

A-428-801 *Antifriction Bearings (Other Than Tapered Roller Bearings), and Parts Thereof*

FAG Aerospace & Superprecision Bearings GmbH—Clarification to determine whether certain aerospace bearings which have entered the United States but have been returned to Germany for repair or refurbishing, and which then reenter the United States, are within the scope of the order.

A-428-821 *Large Newspaper Printing Presses from Germany*

Clarification to determine whether parts for reel tension pasters are within the scope of the order.

Country: Italy

A-475-818 *Certain Pasta*

C-475-819 Joseph A. Sidari Company, Inc.—Clarification to determine whether a shrink wrapped package containing six one-pound packages, each of which would first be individually packaged in a cellophane wrapper (cello) with "Not Labeled for Retail Sale" written across the entire length of each of the individual packages on both sides is with the scope of the antidumping and countervailing duty orders.

Country: People's Republic of China

A-570-501 *Natural Bristle Paint Brushes and Brush Heads*

Kwick Clean and Green Ltd.—Clarification to determine whether a group of bristles held together at the base with glue, which are to be used as replaceable parts within the cavity of the paintbrush body, is within the scope of the order.

A-570-504 *Petroleum Wax Candles*

Sun-It Corporation—Clarification to determine whether taper candles containing oil of citronella are within the scope of the order.

Ocean State Jobbers—Clarification to determine whether taper candles consisting of a blend of petroleum wax and beeswax are within the scope of the order.

American Drug Stores—Clarification to determine whether spherical candles with a "wax veneer" are within the scope of the order.

A-570-808 *Chrome-Plated Lug Nuts*

Wheel Plus, Inc.—Clarification to determine whether imported zinc-plated lug nuts which are chrome-plated in the United States are within the scope of the order.

A-570-827 *Certain Cased Pencils*

Creative Designs International, Ltd.—Clarification to determine whether 10 piece dress-up/vanity sets for young girls, containing two pencils (approximately 3 inches in length with no eraser or ferrule), are within the scope of the order.

Country: Korea

A-580-601 *Certain Stainless Steel Cooking Ware*

C-580-802 Samuel Shapiro & Company—Clarification to determine

whether certain stainless steel pasta and steamer inserts are within the scope of the order.

A-580-803 *Small Business Telephone Systems*

TT Systems Corporation—Clarification to determine whether the "Model 4300" which is a "blocking" system should be excluded from the scope of the order which pertains to "non-blocking" systems.

Country: Taiwan

A-583-009 *Color Television Receivers, Monochrome and Color*

Coach Master International Corporation (CMI)—Clarification to determine whether the Kitchen Coach Unit 8100 manufactured by Action Electronics and imported by CMI is within the scope of the order.

Country: Japan

A-588-028 *Roller Chain, Other Than Bicycle*

Kaga Chain Manufacturer (KCM)—Clarification to determine whether silent timing chain for use in automobiles is within the scope of the order.

A-588-405 *Cellular Mobile Telephones and Subassemblies*

Matsushita Communication Industrial Corporation of America—Clarification to determine whether a new subscriber unit (model number HS600) is within the scope of the order.

A-588-804 *Antifriction Bearings (Other Than Tapered Roller Bearings), and Parts Thereof*

Koyo Seiko Co., Ltd.—Clarification to determine whether a cylindrical roller bearing, allegedly without a precision rating, for use as an axle bearing in cars and trucks is within the scope of the order.

A-588-813 *Light-Scattering Instruments and Parts Thereof*

Thermo Capillary Electrophoresis, Inc.—Clarification to determine whether diode array detectors and cell flow units are within the scope of the order.

A-588-824 *Corrosion Resistant Carbon Steel Flat Products*

Drive Automotive Industries—Clarification to determine whether 2000 millimeter wide, made to order, corrosion resistant carbon steel coils are within the scope of the order.

VI. PENDING ANTICIRCUMVENTION INQUIRIES AS OF DECEMBER 31, 1997

Country: Mexico

A-201-805 *Certain Welded Non-Alloy Steel Pipe*

Allied Tube & Conduit Corp., Sawhill Tubular Division of Tex-Tube Co., Century Tube Corp., Laclede Steel Co., LTV Tubular Products Co., Sharon Tube Co., Western Tube & Conduit Co., Wheatland Tube Co., and CSI Tubular Products, Inc. (Petitioners)—Anticircumvention inquiry to determine whether imports of: (i) Pipe certified to the American Petroleum Institute (API) 5L line pipe specifications (API 5L or line pipe), and (ii) pipe certified to both the API 5L line pipe specifications and the less stringent American Society for Testing and Materials (ASTM) A-53 standard pipe specifications (dual certified pipe), falling within the physical dimensions outlined in the scope of the order, are circumventing the antidumping duty order.

Country: United Kingdom

A-412-810 *Lead and Bismuth Carbon Steel Products*

C-412-811 Inland Steel Bar Company and USS/Kobe Steel Company (Petitioners)—Anticircumvention inquiry to determine whether British Steel PLC is circumventing the order by shipping leaded steel billets to the United States, where they are converted into the hot-rolled carbon steel products covered by the order.

Country: Germany

A-428-811 *Lead and Bismuth Carbon Steel Products*

C-429-812 Inland Steel Bar Company and USS/Kobe Steel Company (Petitioners)—Anticircumvention inquiry to determine whether Saarstahl A.G. and Thyssen s Stahl A.G. are circumventing the order by shipping leaded steel billets to the United States, where they are converted into the hot-rolled carbon steel products covered by the order.

Country: Italy

A-475-818 *Certain Pasta*

Borden, Inc., Hershey Foods Corp., Gooch Foods, Inc. (Petitioners)—Anticircumvention inquiry to determine whether Barilla S.r.L. (Barilla) is importing pasta in the United States in bulk (defined as packages of greater than five pounds) and repackaging the pasta into packages of five pounds or less for sale in the retail market; and whether such repackaging constitutes

circumvention of the antidumping duty order.

Interested parties are invited to comment on the accuracy of the list of pending scope clarification requests. Any comments should be submitted to the Assistant Secretary for Import Administration, International Trade Administration, Room B-099, U.S. Department of Commerce, 14th Street and Constitution Avenue, N.W., Washington, D.C. 20230.

Dated: February 4, 1998.

Richard W. Moreland,

Deputy Assistant Secretary, Import Administration.

[FR Doc. 98-3329 Filed 2-9-98; 8:45 am]

BILLING CODE 3510-DS-P

DEPARTMENT OF COMMERCE

National Institute of Standards and Technology

[Docket No. 971201285-7285-01]

RIN 0693-ZA18

Precision Measurement Grants

AGENCY: National Institute of Standards and Technology, Commerce.

ACTION: Notice.

SUMMARY: The purpose of this notice is to inform potential applicants that the National Institute of Standards and Technology (NIST) is continuing a program of research grants, formally titled Precision Measurement Grants, to faculty members of U.S. universities or colleges for significant, primarily experimental research in the field of fundamental measurement or the determination of fundamental constants. Applicants must submit an abbreviated proposal for preliminary screening. Based on the merit of the abbreviated proposal, applicants will be advised whether a full proposal should be submitted.

DATES: Abbreviated proposals must be received at the address listed above below no later than 5 p.m. EST March 12, 1998. The semi-finalists will be notified of their status by Monday, March 23, 1998, and will be requested to submit their full proposals to NIST by 5 p.m. EDT on Friday, May 8, 1998. Selection of the awards will be made by Friday, August 14, 1998.

ADDRESSES: Applicants are requested to submit an abbreviated proposal (original and two (2) signed copies), using Standards Form 424 (Rev. 4/92) with a description of their proposed work of no more than five (5) double spaced pages. Standard Form 424A(4-92) and 424B(4-92) are also required. Copies should be

sent to the following: Dr. Barry N. Taylor, Chairman, NIST Precision Measurement Grants Committee, Bldg. 225, Rm. B161, National Institute of Standards and Technology, Gaithersburg, MD 20899-0001.

FOR FURTHER INFORMATION CONTACT:

Technical questions concerning the NIST Precision Measurement Grants Programs may be directed to the above address or to Dr. Taylor at 301-975-4220. Prospective applicants with general questions may contact Dr. Taylor before preparing their abbreviated proposal. Specific inquiries as to the usefulness or merit of any particular project, or other specific inquiries that deal with evaluation criteria, can potentially impede the competitive selection process and, therefore, cannot be answered.

Administrative questions concerning the NIST Precision Measurement Grants Program may be directed to the Grants Office at 301-975-6329. Written inquiries should be forwarded to the following address: Grants Office, Acquisition and Assistance Division, Building 301/Room B129, National Institute of Standards and Technology, Gaithersburg, MD 20899-0001.

SUPPLEMENTARY INFORMATION:

Catalog of Federal Domestic Assistance Name and Number

Measurement and Engineering Research and Standards 11.609

Authority

As authorized by Section 2 of the Act of March 3, 1901 as amended (15 U.S.C. 272(b)(2) and (c)(3)), NIST conducts directly, and supports through grants and cooperative agreement, a basic and applied research program in the general area of fundamental measurement and the determination of fundamental constants of nature. The annual budget for Precision Measurement Grants is approximately \$300,000. The annual awards must have scopes of work that are clearly severable that can be easily separated into annual increments of meaningful work which represent solid accomplishments if prospective funding is not made available to the Applicant. Because of commitments for supporting multi-year programs, only a portion of the budget is available to initiate new program in any one year. The issuance of awards is contingent upon availability of funding. As part of this research program since 1970, NIST has awarded Precision Measurement Grants to faculty members of U.S. universities and colleges for significant, primarily experimental research in the field of fundamental measurement or the determination of fundamental constants.

Award Period

NIST is now accepting applications for two new grants in the amount of \$50,000 per year to be awarded for the period October 1, 1998, through September 30, 1999 (fiscal year 1999). Each grant may be renewed for up to two additional years; however, future or continued funding will be at the discretion of NIST based on such factors as satisfactory performance and the availability of funds.

Program Description

NIST sponsors these grants to encourage basic, measurement-related research in U.S. universities and colleges and to foster contacts between NIST scientists and those faculty members of U.S. academic institutions who are actively engaged in such work. The Precision Measurement Grants are also intended to make it possible for such faculty members to pursue new, fundamental measurement ideas for which other sources of support may be difficult to find.

Matching Requirements

The Precision Measurement Grants Program does not involve the payment of any matching funds and does not directly affect any state or local government.

Research Topics

There is some latitude in the kind of research projects that will be considered for support under the Precision Measurement Grants Program. The key requirement is that they are consistent with NIST's mission in the field of basic measurement science, for example.

1. Experimental and theoretical studies of fundamental physical phenomena which test the basic laws of physics or which may lead to new or improved fundamental measurement methods and standards.

2. The determination of important fundamental physical constants.

3. The development of new standards for physical measurement of the highest possible precision and accuracy.

In general, proposals for experimental research will be given preference over proposals for theoretical research because of the greater expense of experimental work. Proposals from workers at the assistant and associate professor level who have some record of accomplishment are especially encouraged in view of the comparative difficulty aspiring researchers have in obtaining funds.

Typical projects which have been funded through the NIST Precision Measurement Grants Program include:

- "Fine-Structure constant determination using precision Stark spectroscopy," Michael G. Littman, Princeton University.
- "Eötös experiment-cryogenic version," D.F. Bartlett, University of Colorado.
- "A test of local Lorentz invariance using polarized ^{21}Ne nuclei," T.E. Chupp, Harvard University.
- "A new method to search for an electric dipole moment of the electron," L.R. Hunder, Amherst College.
- "High precision timing of millisecond pulsars," D.R. Stinebring, Princeton University.
- "Precision optical spectroscopy of positronium," S. Chu, Stanford University.
- "Spectroscopy of Francium: Towards a precise parity non-conservation measurement in a laser trap," L. Orozco, State University of New York at Stony Brook.
- "Measurement of the magnetically-induced birefringence of the vacuum," S.A. Lee, Colorado State University.

Eligibility

Eligible applicants under the Precision Measurement Grants Program are limited to U.S. universities and colleges.

Selection Procedure

To simplify the proposal writing and evaluation process, the following selection procedure will be used:

On the basis of the abbreviated proposals, four to eight semifinalist candidates will be selected by the NIST Precision Measurements Grants Committee and the Outside Review Committee and requested to submit full proposals. The same committees will evaluate the detailed proposals and, on the basis of their evaluation, the two grantees for fiscal year 1999 will be selected.

Evaluation Criteria

The criteria to be used in evaluating the preapplication proposals and full proposals include:

1. Importance of the proposed research to science—does it have the potential of answering some currently pressing question or of opening up a whole new area of activity?
2. The relationship of the proposed research to measurement science—is there a possibility that it will lead to a new or improved fundamental measurement method or to a better understanding of important, but already existing, measurement methods or physical standards?
3. The feasibility of the research—is it likely that significant progress can be made in a three year time period with the funds and personnel available?

4. The past accomplishments of the applicant—is the quality of the research previously carried out by the prospective grantee such that there is a high probability that the proposed research will be successfully carried out?

Each of these factors is given equal weight in the selection process.

Paperwork Reduction Act

The Standard Forms 424, 424A, 424B, and LLL mentioned in this notice are subject to the requirements of the Paperwork Reduction Act (PRA) and have been cleared by the Office of Management and Budget (OMB) under control numbers 0348-0043, 0348-0044, 0348-0040, and 0348-0046. Notwithstanding any other provision of the law, no person is required to respond to, nor shall any person be subject to a penalty for failure to comply with a collection, subject to the requirements of the PRA, unless that collection of information displays a currently valid OMB Control Number.

Application Kit

An application kit, containing all required application forms and certifications, is available by calling Michelle Hane, NIST Precision Measurement Grants Committee, 301-975-4397. An application kit includes the following:

- SF-424 (Rev 4/92)—Application for Federal Assistance
- SF-424A (Rev 4/92)—Budget Information—Non-Construction Programs
- SF-424B (Rev 4/92)—Assurances—Non-Construction Programs
- CD-511 (7/91)—Certifications Regarding Debarment, Suspension and Other Responsibility Matters: Drug-free Workplace Requirements and Lobbying
- CD-512 (7/91)—Certifications Regarding Debarment, Suspension, Ineligibility and Voluntary Exclusion—Lower Tier Covered Transactions and Lobbying
- SF-LLL—Disclosure of Lobbying Activities

Additional Requirements**Past Performance**

Unsatisfactory performance under prior Federal awards may result in an application not being considered for funding.

Preaward Activities

Applicants that incur any costs prior to an award being made do so solely at their own risk of not being reimbursed by the Government. Applicants are also hereby notified that, notwithstanding

any verbal assurance that they may have received, there is no obligation on the part of DoC to cover pre-award costs.

Primary Application Certification

All primary applicants must submit a completed Form CD-511, "Certifications Regarding Debarment, Suspension and Other Responsibility Matters; Drug-Free Workplace Requirements and Lobbying," and the following explanations must be provided.

1. *Nonprocurement Debarment and Suspension.* Prospective participants (as defined at 15 CFR Part 26, Section 105) are subject to 15 CFR Part 26, "Nonprocurement Debarment and Suspension" and the related section of the certification form prescribed above applies;

2. *Drug Free Workplace.* Grantees (as defined at 15 CFR Part 26, Section 605) are subject to 15 CFR Part 26, Subpart F, "Governmentwide Requirements for Drug-Free Workplace (Grants)" and the related section of the certification form prescribed above applies;

3. *anti-Lobbying.* Persons (as defined at 15 CFR Part 28, Section 105) are subject to the lobbying provisions of 31 U.S.C. 1352, "Limitation on use of appropriated funds to influence certain Federal contracting and financial transactions," and the lobbying section of the certification form prescribed above applies to applications/bids for grants, cooperative agreements, and contracts for more than \$100,000, and loans and loan guarantees for more than \$150,000, or the single family maximum mortgage limit for affected programs, whichever is greater; and

4. *Anti-Lobbying Disclosure.* Any applicant that has been paid or will pay for lobbying using any funds must submit an SF-LLL, "Disclosure of Lobbying Activities," as required under 15 CFR Part 28, Appendix B.

5. *Lower Tier Certifications.* Grant recipients shall require applicants/bidders for subgrants, contracts, subcontracts, or other lower tier covered transactions at any tier under the award to submit, if applicable, a completed Form CD-512, "Certifications Regarding Debarment, Suspension, Ineligibility and Voluntary Exclusion-Lower Tier Covered Transactions and Lobbying" and disclosure form, SF-LLL, "Disclosure of Lobbying Activities." Form CD-512 is intended for the use of recipients and should not be transmitted to DoC. SF-LLL submitted by any tier recipient or subrecipient should be submitted to DoC in accordance with the instructions contained in the award document.

Name Check Reviews

All for-profit and nonprofit applicants will be subject to a name check review process. Name checks are intended to reveal if any key individuals associated with the applicant have been convicted of, or are presently facing criminal charges such as fraud, theft, perjury, or other matters which significantly reflect on the applicant's management honesty or financial integrity.

Executive Order Statement

This funding notice was determined to be not significant for purposes of Executive Order 12866.

False Statements

Applicants are reminded that a false statement on an application is grounds for denial or termination of funds and grounds for possible punishment by fine or imprisonment as provided in 18 U.S.C. 1001.

Delinquent Federal Debts

No award of Federal funds shall be made to an applicant who has an outstanding delinquent Federal debt until either:

1. The delinquent account is paid in full;
2. A negotiated repayment schedule is established and at least one payment is received; or
3. Other arrangements satisfactory to DoC are made.

No Obligation for Future Funding

In an application is accepted for funding, DoC has no obligation to provide any additional future funding in connection with that award. Renewal of an award, increased funding, or extending the period of performance is at the total discretion of NIST.

Federal Policies and Procedures

Recipients and subrecipients under the Precision Measurement Grants Program are subject to all Federal laws and Federal and Departmental policies, regulations, and procedures applicable to Federal financial assistance awards. The Precision Measurement Grants Program does not directly affect any state or local government. Applications under this program are not subject to Executive Order 12372, "Intergovernmental Review of Federal Programs."

Buy American-Made Equipment or Products

Applicants are hereby notified that they are encouraged, to the greatest extent practicable, to purchase American-made equipment and

products with funding provided under this program.

Indirect Costs

The total dollar amount of the indirect costs proposed in an application under this program must not exceed the indirect cost rate negotiated and approved by a cognizant Federal agency prior to the proposed effective date of the award or 100 percent of the total proposed direct costs dollar amount in the application, whichever is less.

Dated: February, 4, 1998.

Robert E. Hebner,

Acting Deputy Director.

[FR Doc. 98-3311 Filed 2-9-98; 8:45 am]

BILLING CODE 3510-13-M

DEPARTMENT OF COMMERCE

National Oceanic and Atmospheric Administration

[I.D. 020298C]

Pacific Fishery Management Council; Public Meetings and Hearings

AGENCY: National Marine Fisheries Service (NMFS), National Oceanic and Atmospheric Administration (NOAA), Commerce.

ACTION: Notice of availability of reports; notice of public meetings and hearings.

SUMMARY: The Pacific Fishery Management Council (Council) has begun its annual preseason management process for the 1998 ocean salmon fisheries. This notice announces the availability of Council documents and the dates and locations of Council meetings and public hearings. These actions comprise the complete schedule of events followed by the Council for determining the annual proposed and final modifications to ocean salmon management measures.

DATES: Written comments on the season options must be received by April 2, 1998.

ADDRESSES: Written comments should be sent to Lawrence D. Six, Executive Director, Pacific Fishery Management Council, 2130 SW Fifth Avenue, Suite 224, Portland, OR 97201; telephone: (503) 326-6352. See **SUPPLEMENTARY INFORMATION** for dates, times, and locations of public meetings and hearings.

Council address: Pacific Fishery Management Council, 2130 SW Fifth Avenue, Suite 224, Portland, OR 97201. **FOR FURTHER INFORMATION CONTACT:** John Coon, Salmon Management Coordinator; telephone: (503) 326-6352.

SUPPLEMENTARY INFORMATION:

March 2, 1998: Council reports which summarize the 1997 salmon season and project the expected salmon stock abundance for 1998 are available to the public from the Council office.

March 9-13, 1998: Council and advisory entities meet at the Clarion Hotel, 401 East Millbrae Avenue, Millbrae, California, to adopt 1998 regulatory options for public review.

March 25, 1998: Report with proposed management options and public hearing schedule is mailed to the public. (The report includes options, rationale, and summary of biological and economic impacts.)

March 30-April 7, 1998: Public hearings are held to receive comments on the proposed ocean salmon fishery regulatory options adopted by the Council. All public hearings begin at 7 p.m. on the dates and at the locations specified below:

March 30, 1998: Westport High School Commons, 2850 S. Montesano Street, Westport, WA.

March 30, 1998: Pony Village Motor Lodge, Ballroom, Virginia Avenue, North Bend, OR.

March 31, 1998: Shilo Inn, Wilson River Room, 2535 North Main, Tillamook, OR.

March 31, 1998: Red Lion Inn, Evergreen Room, 1929 Fourth Street, Eureka, CA.

April 1, 1998: Red Lion's Sacramento Inn, Yosemite Room, 1401 Arden Way, Sacramento, CA.

April 6-10, 1998: Council and its advisory entities meet at the Doubletree Hotel - Columbia River, Portland, OR, to adopt final 1998 regulatory measures.

April 17, 1998: Newsletter describing adopted ocean salmon fishing management measures is mailed to the public.

April 11-22, 1998: Salmon Technical Team completes "Preseason Report III Analysis of Council Adopted Regulatory Measures for 1998 Ocean Salmon Fisheries."

May 1, 1998: Federal regulations implemented and Preseason Report III available for distribution to the public.

Although other issues not contained in this agenda may come before this Council for discussion, in accordance with the Magnuson-Stevens Fishery Conservation and Management Act, those issues may not be the subject of formal Council action during this meeting. Council action will be restricted to those issues specifically identified in the agenda listed in this notice.

Special Accommodations

The meetings are physically accessible to people with disabilities.

Requests for sign language interpretation or other auxiliary aids should be directed to Mr. Eric Greene at (503) 326-6352 at least 5 days prior to the meeting date.

Dated: February 4, 1998.

Bruce C. Morehead,

Acting Director, Office of Sustainable Fisheries, National Marine Fisheries Service.

[FR Doc. 98-3330 Filed 2-9-98; 8:45 am]

BILLING CODE 3510-22-F

DEPARTMENT OF COMMERCE

National Oceanic and Atmospheric Administration

[I.D. 020498C]

Marine Mammals

AGENCY: National Marine Fisheries Service (NMFS), National Oceanic and Atmospheric Administration (NOAA), Commerce.

ACTION: Issuance of permit amendment.

SUMMARY: Notice is hereby given that Alaska Department of Fish and Game, P.O. Box 25526, Juneau, AK 99802-5526 has been issued an amendment to scientific research Permit No. 965 (P66j).

ADDRESSES: The amendment and related documents are available for review upon written request or by appointment in the following office(s):

Permits and Documentation Division, Office of Protected Resources, NMFS, 1315 East-West Highway, Room 13705, Silver Spring, MD 20910 (301/713-2289);

Regional Administrator, Alaska Region, National Marine Fisheries Service, NOAA, P.O. Box 21668, Juneau, AK 99802-1668.

FOR FURTHER INFORMATION CONTACT: Sara Shapiro or Ruth Johnson, 301/713-2289.

SUPPLEMENTARY INFORMATION: On December 23, 1997, notice was published in the *Federal Register* (62 FR 67053) that an amendment of Permit No. 965, issued June 19, 1995 (60 FR 34233), had been requested by the above-named [individual/organization]. The requested amendment has been granted under the authority of the Marine Mammal Protection Act of 1972, as amended (16 U.S.C. 1361 *et seq.*), the provisions of § 216.39 of the Regulations Governing the Taking and Importing of Marine Mammals (50 CFR part 216), the Endangered Species Act of 1973, as amended (ESA; 16 U.S.C. 1531 *et seq.*), and the provisions of § 222.25 of the regulations governing the taking, importing, and exporting of endangered fish and wildlife (50 CFR 222.23).

Permit No. 965 (P66j) is now amended for: Underwater capture of 10 additional (25 total) juvenile Steller sea lions, *Eumetopias jubatus*, through use of a leash around each animal's neck, with the opposite end of the leash attached to a buoy at the surface; and use of diazepam, xylazine, or medetomidine as a sedative with either flumazenil, tolazoline, or atipamezole as the reversal agent.

Issuance of this amendment, as required by the ESA was based on a finding that such permit (1) was applied for in good faith, (2) will not operate to the disadvantage of the endangered species which is the subject of this permit, and (3) is consistent with the purposes and policies set forth in section 2 of the ESA.

Dated: January 30, 1998.

Ann D. Terbush,

Chief, Permits and Documentation Division, Office of Protected Resources, National Marine Fisheries Service.

[FR Doc. 98-3331 Filed 2-9-98; 8:45 am]

BILLING CODE 3510-22-F

COMMITTEE FOR THE IMPLEMENTATION OF TEXTILE AGREEMENTS

Increase of a Guaranteed Access Level for Certain Cotton and Man-Made Fiber Textile Products Produced or Manufactured in El Salvador

February 4, 1998.

AGENCY: Committee for the Implementation of Textile Agreements (CITA).

ACTION: Issuing a directive to the Commissioner of Customs increasing a guaranteed access level.

EFFECTIVE DATE: February 11, 1998.

FOR FURTHER INFORMATION CONTACT: Roy Unger, International Trade Specialist, Office of Textiles and Apparel, U.S. Department of Commerce, (202) 482-4212. For information on the quota status of this level, refer to the Quota Status Reports posted on the bulletin boards of each Customs port or call (202) 927-5850. For information on embargoes and quota re-openings, call (202) 482-3715.

SUPPLEMENTARY INFORMATION:

Authority: Section 204 of the Agricultural Act of 1956, as amended (7 U.S.C. 1854); Executive Order 11651 of March 3, 1972, as amended.

Upon a request from the Government of El Salvador, the U.S. Government has agreed to increase the current guaranteed access level for Categories 352/652 to 12,000,000 dozen.

A description of the textile and apparel categories in terms of HTS numbers is available in the CORRELATION: Textile and Apparel Categories with the Harmonized Tariff Schedule of the United States (see Federal Register notice 62 FR 66057, published on December 17, 1997). Also see 62 FR 67623, published on December 29, 1997.

Troy H. Cribb,

Chairman, Committee for the Implementation of Textile Agreements.

Committee for the Implementation of Textile Agreements

February 4, 1998.

Commissioner of Customs,

Department of the Treasury, Washington, DC 20229.

Dear Commissioner: This directive amends, but does not cancel, the directive issued to you on December 19, 1997, by the Chairman, Committee for the Implementation of Textile Agreements. That directive concerns imports of certain cotton and man-made fiber textile products, produced or manufactured in El Salvador and exported during the periods January 1, 1998 through March 26, 1998 and January 1, 1998 through December 31, 1998.

Effective on February 11, 1998, you are directed to increase the guaranteed access level for Categories 352/652 to 12,000,000 dozen for the period January 1, 1998 through March 26, 1998.

The Committee for the Implementation of Textile Agreements has determined that this action falls within the foreign affairs exception of the rulemaking provisions of 5 U.S.C. 553(a)(1).

Sincerely,

Troy H. Cribb,

Chairman, Committee for the Implementation of Textile Agreements.

[FR Doc. 98-3304 Filed 2-9-98; 8:45 am]

BILLING CODE 3510-DR-F

DEPARTMENT OF DEFENSE

General Services Administration

National Aeronautics and Space Administration

[OMB Control No. 9000-0012]

Proposed Collection; Comment Request Entitled Termination Settlement Proposal Forms—FAR (Standard Forms 1435 through 1440)

AGENCIES: Department of Defense (DOD), General Services Administration (GSA), and National Aeronautics and Space Administration (NASA).

ACTION: Notice of request for public comments regarding an extension to an existing OMB clearance (9000-0012).

SUMMARY: Under the provisions of the Paperwork Reduction Act of 1995 (44

U.S.C. Chapter 35), the Federal Acquisition Regulation (FAR) Secretariat will be submitting to the Office of Management and Budget (OMB) a request to review and approve an extension of a currently approved information collection requirement concerning Termination Settlement Proposal Forms—FAR (Standard Forms 1435 through 1440). The clearance currently expires on May 31, 1998.

DATES: Comments may be submitted on or before April 13, 1998.

FOR FURTHER INFORMATION CONTACT: Linda Klein, Federal Acquisition Policy Division, GSA (202) 501-3775.

ADDRESSES: Comments regarding this burden estimate or any other aspect of this collection of information, including suggestions for reducing this burden, should be submitted to: FAR Desk Officer, OMB, Room 10102, NEOB, Washington, DC 20503, and a copy to the General Services Administration, FAR Secretariat, 1800 F Street, NW, Room 4037, Washington, DC 20405. Please cite OMB Control No. 9000-0012, Termination Settlement Proposal—FAR (SF's 1435 through 1440), in all correspondence.

FOR FURTHER INFORMATION CONTACT: Linda Klein, Federal Acquisition Policy Division, GSA (202) 501-3775.

SUPPLEMENTARY INFORMATION:

A. Purpose

The termination settlement proposal forms (Standard Forms 1435 through 1440) provide a standardized format for listing essential cost and inventory information needed to support the terminated contractor's negotiation position. Submission of the information assures that a contractor will be fairly reimbursed upon settlement of the terminated contract.

B. Annual Reporting Burden

Public reporting burden for this collection of information is estimated to average 2.5 hours per response, including the time for reviewing instructions, searching existing data sources, gathering and maintaining the data needed, and completing and reviewing the collection of information.

The annual reporting burden is estimated as follows: Respondents, 600; responses per respondent, 1; total annual responses, 600; preparation hours per response, 2.5; and total response burden hours, 15,000.

Obtaining Copies of Proposals

Requester may obtain a copy of the justification from the General Services Administration, FAR Secretariat (MVRs), 1800 F Street, NW, Room 4037,

Washington, DC 20405, telephone (202) 501-4755. Please cite OMB Control No. 9000-0012, Termination Settlement Proposal Forms—FAR (SF's 1435 through 1440), in all correspondence.

Dated: February 5, 1998.

Sharon A. Kiser,

FAR Secretariat.

[FR Doc. 98-3284 Filed 2-9-98; 8:45 am]

BILLING CODE 6820-34-P

DEPARTMENT OF DEFENSE

Department of the Navy

Availability of Government Owned Inventions for Licensing

AGENCY: Department of the Navy, DoD.

ACTION: Notice of availability of government owned inventions for licensing.

SUMMARY: The inventions listed below are assigned to the United States Government as represented by the Secretary of the Navy and are made available for licensing by the Department of the Navy.

ADDRESSES:

Patents—Copies of patents cited are available from the Commissioner of Patents and Trademarks, Washington, D.C. 20231, for \$3.00 each. Requests for copies of patents must include the patent number.

Patent applications—Copies of patent applications cited are available from the National Technical Information Service (NTIS), Springfield, Virginia 22161 for \$6.95 each (\$10.95 outside North American Continent). Requests for copies of patent applications must include the patent application serial number. Claims are deleted from the copies of patent applications sold to avoid premature disclosure.

FOR FURTHER INFORMATION CONTACT: Mr. R.J. Erickson, Staff Patent Attorney, Office of Naval Research (Code OOC), Arlington, VA 22217-5660, telephone (703) 696-4001.

SUPPLEMENTARY INFORMATION: *The following patents are available for licensing:*

Patent 5,595,635: APPARATUS FOR MEASURING LEAD CONTENT OF WATER; filed 8 September 1995; patented 21 January 1997.

Patent 5,600,335: HIGH-POWER BROADBAND ANTENNA; filed 21 December 1994; patented 4 February 1997.

Patent 5,600,340: WIDEBAND OMNI-DIRECTIONAL ANTENNA; filed 13 April 1995; patented 4 February 1997.

- Patent 5,600,440: LIQUID CRYSTAL INTERFEROMETER; filed 5 July 1995; patented 4 February 1997.
- Patent 5,602,403: ION IMPLANTATION BURIED GATE INSULATOR FIELD EFFECT TRANSISTOR; filed 1 March 1991; patented 11 February 1997.
- Patent 5,602,751: METHOD AND APPARATUS FOR SPECTRUM ANALYSIS BY COMPLEX CUMULANTS; filed 28 February 1995; patented 11 February 1997.
- Patent 5,610,598: MISSILE TELEMETRY DATA INTERFACE CIRCUIT; filed 18 March 1996; patented 11 March 1997.
- Patent 5,612,929: SPECTRAL PROCESSOR AND RANGE DISPLAY UNIT; filed 27 December 1995; patented 18 March 1997.
- Patent 5,615,632: UNDERWATER VEHICLE AND A FIN ASSEMBLY THEREFOR; filed 7 February 1996; patented 1 April 1997.
- Patent 5,615,847: SUBMARINE LAUNCHED UNMANNED AERIAL VEHICLE; filed 11 September 1995; patented 1 April 1997.
- Patent 5,617,352: NON-VOLATILE, BIDIRECTIONAL, ELECTRICALLY PROGRAMMABLE INTEGRATED MEMORY ELEMENT IMPLEMENTED USING DOUBLE POLYSILICON; filed 13 December 1995; patented 1 April 1997.
- Patent 5,617,869: DEVICE AND METHOD FOR LOCATING FLOW BLOCKAGE IN A THREE-DIMENSIONAL OBJECT; filed 16 June 1995; patented 8 April 1997.
- Patent 5,619,079: EMI LINE FILTER; filed 28 July 1995; patented 8 April 1997.
- Patent 5,619,432: DISCRIMINATE REDUCTION DATA PROCESSOR; filed 5 April 1995; patented 8 April 1997.
- Patent 5,619,945: DRAG REDUCTION POLYMER EJECTION SYSTEM FOR UNDERWATER VEHICLE; filed 16 January 1996; patented 15 April 1997.
- Patent 5,623,096: ORTHOGONAL SHEAR STRESS MEASUREMENT PROBE ASSEMBLY FOR BOUNDARY LAYER FLOW; filed 19 June 1995; patented 22 April 1997.
- Patent 5,623,524: METHOD AND APPARATUS FOR MEASURING THE DEPTH OF AN UNDERWATER TARGET; filed 1 March 1967; patented 22 April 1997.
- Patent 5,625,146: METHOD AND SYSTEM FOR DETERMINING AXIAL MODULUS; filed 18 December 1995; patented 29 April 1997.
- Patent 5,625,320: DIFFERENTIAL PREAMPLIFIER AND PRE-EMPHASIS NETWORK; filed 7 October 1994; patented 29 April 1997.
- Patent 5,625,605: OPTIC BUNDLE TOWED ARRAY; filed 13 September 1983; patented 29 April 1997.
- Patent 5,626,166: TEMPERATURE CONTROL VALVE WITHOUT MOVING PARTS; filed 7 February 1996; patented 6 May 1997.
- Patent 5,627,339: ENERGETIC COMPOSITIONS CONTAINING NO VOLATILE SOLVENTS; filed 28 March 1996; patented 6 May 1997.
- Patent 5,627,521: PERSONAL MICROWAVE AND RADIO FREQUENCY DETECTOR; filed 9 May 1994; patented 6 May 1997.
- Patent 5,628,974: PROCESS FOR TREATING BY-PRODUCTS OF LITHIUM/SULFUR HEXAFLUORIDE; filed 7 July 1995; patented 13 May 1997.
- Patent 5,629,248: MODIFIED GERMANIUM SULFIDE GLASS; filed 10 October 1995; patented 13 May 1997.
- Patent 5,631,406: CHEMICAL COMPOUNDS; filed 30 March 1981; patented 20 May 1997.
- Patent 5,631,877: NARROWBAND SIGNAL REVEALER; filed 11 January 1996; patented 20 May 1997.
- Patent 5,632,218: DEBRIS DEFLECTOR; filed 5 August 1996; patented 27 May 1997.
- Patent 5,632,580: MILLING MACHINE EXTENSION; filed 31 March 1995; patented 27 May 1997.
- Patent 5,632,655: ELECTRICAL CONNECTOR WITH REPLACEABLE MALE PINS; filed 20 March 1995; patented 27 May 1997.
- Patent 5,632,658: TRACTOR PRODDDED PROPULSOR FOR SURFACE SHIPS; filed 21 May 1996; patented 27 May 1997.
- Patent 5,632,659: COMBUSTION CHAMBER DRAIN SYSTEM; filed 20 February 1996; patented 27 May 1997.
- Patent 5,633,748: FIBER OPTIC BRAGG GRATING DEMODULATOR AND SENSOR INCORPORATING SAME; filed 5 March 1996; patented 27 May 1997.
- Patent 5,633,960: SPATIALLY AVERAGING FIBER OPTIC ACCELEROMETER SENSORS; filed 25 September 1996; patented 27 May 1997.
- Patent 5,634,246: SNAP SWIVEL HOOK ASSEMBLY INCORPORATING BALL SWIVEL AND RECESSED HOOK LATCH RELEASE MECHANISM; filed 20 November 1995; patented 3 June 1997.
- Patent 5,635,144: LOW TEMPERATURE PLASMA FILM DEPOSITION USING DIELECTRIC CHAMBER AS SOURCE MATERIAL; filed 24 January 1996; patented 3 June 1997.
- Patent 5,635,662: METHOD AND APPARATUS FOR AVOIDING DETECTION BY A THREAT PROJECTILE; filed 7 February 1996; patented 3 June 1997.
- Patent 5,636,180: SYSTEM FOR PREVENTING BIOFOULING OF SURFACES EXPOSED TO WATER; filed 16 August 1995; patented 3 June 1997.
- Patent 5,636,248: METHOD AND SYSTEM FOR REGENERATING AMPLITUDE AND TIMING CHARACTERISTICS OF AN ANALOG SIGNAL; filed 4 October 1994; patented 3 June 1997.
- Patent 5,636,307: FIBER OPTIC MICROCABLE PRODUCED WITH RADIATION CURED COMPOSITE; filed 22 November 1993; patented 3 June 1997.
- Patent 5,637,825: CONTROL LINE SPOOL; filed 17 January 1996; patented 10 June 1997.
- Patent 5,637,826: METHOD AND APPARATUS FOR OPTIMAL GUIDANCE; filed 7 February 1996; patented 10 June 1997.
- Patent 5,637,865: FIBER OPTIC SELF-MULTIPLEXING AMPLIFIED RING TRANSDUCER AND FORCE TRANSFER SENSOR WITH PRESSURE COMPENSATION; filed 11 June 1996; patented 10 June 1997.
- Patent 5,637,883: OPTICALLY ADDRESSED SPATIAL LIGHT MODULATOR USING AN INTRINSIC SEMICONDUCTOR ACTIVE MATERIAL AND HIGH RESISTIVITY CLADDING LAYERS; filed 27 February 1995; patented 10 June 1997.
- Patent 5,638,004: MULTICONDUCTOR CONTINUITY AND INTERMITTENT FAULT ANALYZER WITH DYNAMIC STIMULATION; filed 16 May 1995; patented 10 June 1997.
- Patent 5,639,022: SUPERSONIC FLUID DISPERSING INJECTOR; filed 30 November 1994; patented 17 June 1997.
- Patent 5,639,318: OXIDATION RESISTANT COPPER; filed 24 August 1995; patented 17 June 1997.
- Patent 5,639,968: OPTICAL FIBER STRAIN-TO-FAILURE SENSOR; filed 23 October 1995; patented 17 June 1997.
- Patent 5,639,982: MEANS TO FIRE A FULLY AUTOMATIC GUN UNDERWATER USING A SPECIAL BARREL CLEARANCE BLANK ROUND; filed 23 May 1996; patented 17 June 1997.
- Patent 5,641,189: MULTIPLE STRAP CARRIER; filed 17 November 1995; patented 24 June 1997.
- Patent 5,641,440: SINTERING AIDS FOR PRODUCING BAO.AL2O3.2SIO2 AND SRO.AL2O3.2SIO2 CERAMIC MATERIALS; filed 26 July 1995; patented 24 June 1997.
- Patent 5,641,936: ACTIVE INFRARED FUZE; filed 11 September 1964; patented 24 June 1997.

Patent 5,642,329: METHOD FOR DOUBLING THE RESOLVING POWER OF A SONAR ARRAY AND A SONAR ARRAY FOR IMPLEMENTING THE SAME; filed 3 October 1995; patented 24 June 1997.

Patent 5,642,330: SEA STATE MEASURING SYSTEM; filed 2 May 1994; patented 24 June 1997.

Patent 5,642,331: CONSTANT RADIUS ACOUSTIC SENSOR MOUNTING SYSTEM; filed 2 February 1996; patented 24 June 1997.

Patent 5,642,445: SYSTEM FOR DETERMINING AN INTERIOR OR EXTERIOR ACOUSTIC NOISE LEVEL OF AN ENCLOSED STRUCTURE AND NOISE REDUCTION DEVICE INCORPORATING SUCH SYSTEM; filed 31 October 1995; patented 24 June 1997.

Patent 5,644,067: APPARATUS AND METHOD FOR CALIBRATION OF SENSING TRANSDUCERS; filed 16 July 1996; patented 1 July 1997.

The following patent applications are available for licensing:

Patent application 06/279,414: FORMATION OF COMPOSITE MATERIALS BY THE INWARD DIFFUSION AND PRECIPITATION OF THE MATRIX PHASE; filed 1 July 1981.

Patent application 08/084,057: TOOL AND SYSTEM FOR MACHINING A ROUND STAND; filed 30 June 1993.

Patent application 08/433,857: HIGH SPEED MAGNETOSTRICTIVE LINEAR MOTOR; filed 2 May 1995.

Patent application 08/491,047: HIGH-ENERGY-ABSORBING ENCLOSURE FOR INTERNAL EXPLOSION CONTAINMENT; filed 15 June 1995.

Patent application 08/527,988: BICOUPLED CONTRAROTATING EPICYCLIC GEARS; filed 14 September 1995.

Patent application 08/530,391: VIBRATION-DAMPING OF STRUCTURAL PRODUCTS; filed 19 September 1995.

Patent application 08/532,347: METHOD AND APPARATUS FOR HEATED, PRESSURE-SWING HIGH PRESSURE AIR DEHYDRATION; filed 22 September 1995.

Patent application 08/645,732: ISOLATION MOUNTING DEVICE; filed 14 May 1996.

Patent application 08/669,673: TWO PHASE HFB₂-SIB₄ MATERIAL; filed 24 June 1996.

Patent application 08/695,444: PROCESS FOR MAKING OPTICAL FIBERS FROM CORE AND CLADDING GLASS RODS; filed 12 August 1996.

Patent application 08/704,028: ENERGETIC NITRO PREPOLYMER; filed 26 August 1996.

Patent application 08/704,029: ENERGETIC FLUORONITRO PREPOLYMER; filed 26 August 1996.

Patent application 08/714,876: COMPACT CONTINUOUS WAVE TUNABLE INFRARED LASERS AND METHOD; filed 19 September 1996.

Patent application 08/736,551: AMPLITUDE INSENSITIVE SYNCHRONIZATION OF NONLINEAR SYSTEMS; filed 24 October 1996.

Patent application 08/745,169: METHOD AND APPARATUS FOR CASTING THIN-WALLED HONEYCOMB STRUCTURES; filed 7 November 1996.

Patent application 08/747,469: METHOD AND APPARATUS FOR PERFORMING MUTATIONS IN A GENETIC ALGORITHM-BASED UNDERWATER TARGET TRACKING SYSTEM; filed 12 November 1996.

Patent application 08/749,483: APPARATUS AND METHOD FOR GENERATING SHORT PULSES FOR NMR AND NQR PROCESSING; filed 13 November 1996.

Patent application 08/753,055: SHIELDED BEARING LUBRICATION; filed 19 November 1996.

Patent application 08/769,641: MULTI-LAYER TILED ARRAY; filed 16 December 1996.

Patent application 08/774,800: SUBMARINE EXTENDIBLE TURRET SYSTEM; filed 28 February 1997.

Patent application 08/775,232: SYSTEM FOR VERIFYING NUCLEAR WARHEAD PREAMM/SAFING SIGNALS; filed 30 December 1996.

Patent application 08/775,233: TRAJECTORY MEASUREMENT SYSTEM FOR UNDERWATER VEHICLES; filed 30 December 1996.

Patent application 08/775,486: OXIDATION RESISTANT FIBER-REINFORCED COMPOSITES WITH POLY(CARBORANE-SILOXANE/SILANE-ACETYLENE); filed 31 December 1996.

Patent application 08/782,362: MODEL IDENTIFICATION AND CHARACTERIZATION OF ERROR STRUCTURES IN SIGNAL PROCESSING; filed 13 January 1997.

Patent application 08/787,834: TRAJECTORY MATCHED PASSIVE DETECTION SYSTEM; filed 23 January 1997.

Patent application 08/789,454: ACTIVE SONAR RANGE-BEAM PARTITIONER; filed 1 January 1997.

Patent application 08/791,292: PHASE STABILIZATION OF ZIRCONIA; filed 30 January 1997.

Patent application 08/791,297: METHODS AND APPARATUS FOR DISTRIBUTED OPTICAL FIBER SENSING OF STRAIN OR MULTIPLE PARAMETERS; filed 30 January 1997.

Patent application 08/791,433: APPARATUS AND METHOD OF CONCOMITANT SCENARIO TOPOGRAPHY WITH THE AID OF A DIGITAL COMPUTER; filed 27 January 1997.

Patent application 08/792,240: SYSTEM FOR BEARINGS-ONLY CONTACT STATE ESTIMATION USING RECURRENT NEURAL NETWORKS; filed 31 January 1997.

Patent application 08/792,266: SYSTEM AND METHOD FOR TRACKING VEHICLES USING RANDOM SEARCH ALGORITHMS; filed 31 January 1997.

Patent application 08/792,676: METHOD AND APPARATUS FOR PRODUCING HIGH BRIGHTNESS MID-IR FLUORESCENCE FROM PHOSPHOR MATERIALS; filed 29 January 1997.

Patent application 08/797,325: PHOTOACTIVATABLE O-NITROBENZYL POLYETHYLENE GLYCOL-SILANE FOR THE PRODUCTION OF PATTERNED BIOMOLECULAR ARRAYS; filed 10 February 1997.

Patent application 08/797,765: IMPROVED COMPOSITIONS FOR USE IN BATTERY SYSTEMS; filed 8 January 1997.

Patent application 08/800,328: WET-SPINNING FIBER PROCESS PROVIDING CONTROLLED MORPHOLOGY OF THE WET-SPUN FIBER; filed 12 March 1996.

Patent application 08/802,573: WAVELET-BASED HYBRID NEUROSYSTEM FOR SIGNAL CLASSIFICATION; filed 19 February 1997.

Patent application 08/804,044: WATER SPRAY COOLING SYSTEM FOR EXTINGUISHMENT AND POST FIRE SUPPRESSION OF COMPARTMENT FIRES; filed 26 February 1997.

Patent application 08/806,132: CABLE FLUSHING LATERAL; filed 3 March 1997.

Patent application 08/810,165: HIGH SPEED WAVELENGTH DETERMINATION SYSTEM FOR WAVELENGTH-ENCODE SENSORS; filed 28 February 1997.

Patent application 08/810,166: FIBER BRAGG GRATING INTERROGATION SYSTEM AND METHOD WITH FIBER STRING MULTIPLEXING; filed 28 February 1997.

Patent application 08/810,167: FIBER BRAGG GRATING INTERROGATION SYSTEM WITH ADAPTIVE CALIBRATION; filed 28 February 1997.

Patent application 08/812,065: TOWED ARRAY WITH NON-ACOUSTIC SENSOR MODULE; filed 21 January 1997.

Patent application 08/818,193: NOVEL LINEAR METALLOCENE POLYMERS CONTAINING ACETYLENIC AND INORGANIC UNITS AND THERMOSETS AND CERAMICS THEREFROM; filed 14 March 1997.

Patent application 08/823,776: RETRACTABLE UNDERWATER TURRET; filed 24 March 1997.

Patent application 08/825,942: ACTIVELY MODE-LOCKED, SINGLE-POLARIZATION, PICOSECOND OPTICAL FIBER LASER; filed 1 April 1997.

Patent application 08/828,229: STANDARDIZED MODULAR ANTENNA SYSTEM; filed 14 April 1997.

Patent application 08/828,232: STRUT-MOUNTED DRAG BALANCE; filed 25 March 1997.

Patent application 08/845,894: MICROCAPILLARY-BASED FLOW-THROUGH IMMUNOSENSOR AND DISPLACEMENT IMMUNOASSAY USING THE SAME; filed 28 April 1997.

Patent application 08/845,897: POROUS METAL/ORGANIC POLYMERIC COMPOSITES; filed 28 April 1997.

Patent application 08/846,192: LIGHTWEIGHT HIGH DAMPING POROUS METAL/PTHALONITRILE COMPOSITES; filed 28 April 1997.

(Authority: 35 U.S.C. 207; 37 CFR Part 404)

Dated: January 29, 1998.

Michael I. Quinn,

Lieutenant Commander, Judge Advocate General's Corps, U.S. Navy, Federal Register Liaison Officer.

[FR Doc. 98-3223 Filed 2-9-98; 8:45 am]

BILLING CODE 3810-FF-P

DEPARTMENT OF EDUCATION

Notice of Proposed Information Collection Requests

AGENCY: Department of Education.

ACTION: Notice of proposed information collection requests.

SUMMARY: The Acting Deputy Chief Information Officer, Office of the Chief Information Officer, invites comments on the proposed information collection requests as required by the Paperwork Reduction Act of 1995.

DATES: An emergency review has been requested in accordance with the Act (44 U.S.C. Chapter 3507 (j)), since public harm is reasonably likely to result if normal clearance procedures are followed. Approval by the Office of Management and Budget (OMB) has been requested by February 9, 1998. A regular clearance process is also

beginning. Interested persons are invited to submit comments on or before April 10, 1998.

ADDRESSES: Written comments regarding the emergency review should be addressed to the Office of Information and Regulatory Affairs, Attention: Danny Werfel, Desk Officer: Department of Education, Office of Management and Budget, 725 17th Street, NW., Room 10235, New Executive Office Building, Washington, D.C. 20503. Requests for copies of the proposed information collection request should be addressed to Patrick J. Sherrill, Department of Education, 7th & D Streets, S.W., Room 5624, Regional Office Building 3, Washington, D.C. 20202-4651.

Written comments regarding the regular clearance and requests for copies of the proposed information collection requests should be addressed to Patrick J. Sherrill, Department of Education, 600 Independence Avenue, S.W., Room 5624, Regional Office Building 3, Washington, DC 20202-4651, or should be electronic mailed to the internet address Pat_Sherrill@ed.gov, or should be faxed to 202-708-9346.

FOR FURTHER INFORMATION CONTACT:

Patrick J. Sherrill (202) 708-8196. Individuals who use a telecommunications device for the deaf (TDD) may call the Federal Information Relay Service (FIRS) at 1-800-877-8339 between 8 a.m. and 8 p.m., Eastern time, Monday through Friday.

SUPPLEMENTARY INFORMATION: Section 3506 (c)(2)(A) of the Paperwork Reduction Act of 1995 (44 U.S.C. Chapter 3506 (c)(2)(A) requires that the Director of OMB provide interested Federal agencies and the public an early opportunity to comment on information collection requests. The Office of Management and Budget (OMB) may amend or waive the requirement for public consultation to the extent that public participation in the approval process would defeat the purpose of the information collection, violate State or Federal law, or substantially interfere with any agency's ability to perform its statutory obligations. The Acting Deputy Chief Information Officer, Office of the Chief Information Officer, publishes this notice containing proposed information collection requests at the beginning of the Departmental review of the information collection. Each proposed information collection, grouped by office, contains the following: (1) Type of review requested, e.g., new, revision, extension, existing or reinstatement; (2) Title; (3) Summary of the collection; (4) Description of the need for, and proposed use of, the information; (5)

Respondents and frequency of collection; and (6) Reporting and/or Recordkeeping burden. ED invites public comment at the address specified above. Copies of the requests are available from Patrick J. Sherrill at the address specified above.

The Department of Education is especially interested in public comment addressing the following issues: (1) Is this collection necessary to the proper functions of the Department, (2) will this information be processed and used in a timely manner, (3) is the estimate of burden accurate, (4) how might the Department enhance the quality, utility, and clarity of the information to be collected, and (5) how might the Department minimize the burden of this collection on the respondents, including through the use of information technology.

Dated: February 5, 1998.

Linda C. Tague,

Acting Deputy Chief Information Officer, Office of the Chief Information Officer.

Office of Management

Type of Review: New.

Title: Streamlined Process for the Education Department General Administrative Regulations (EDGAR) Approved Grant Applications.

Abstract: Since April 1997, EDGAR's menu of selection criteria became effective. For each competition, the Secretary would select one or more criteria that best enable the Department to identify the highest quality applications consistent with the program purpose, statutory requirements, and any priorities established. This allowed the Secretary the flexibility to weigh the criteria according to the needs of each individual program. This menu of selection criteria will provide the Department the flexibility to choose a set of criteria tailored to a given competition and obviate the need to create specific selection criteria through individual program regulations. ED is requesting a streamlined process for programs of approved applications who choose to change: (1) criteria from the same EDGAR menu, (2) old EDGAR to new EDGAR criteria, or (3) program criteria to EDGAR criteria.

Additional Information: ED is requesting an emergency clearance by February 9, 1998. This will allow programs to make the appropriate criteria changes without further delaying the grant process and provide sufficient time for applicants to complete their applications. Without this emergency request, applicants

would not receive their awards in time which could result in public harm.

Frequency: Annually.

Affected Public: Businesses or other for-profits; Not-for-profit institutions; State, Local or Tribal Gov't, SEAs or LEAs.

Annual Reporting and Recordkeeping Hour Burden:

Responses: 1

Burden Hours: 1

[FR Doc. 98-3456 Filed 2-9-98; 8:45 am]

BILLING CODE 4000-01-P

DEPARTMENT OF EDUCATION

Submission for OMB Review; Comment Request

AGENCY: Department of Education.

ACTION: Submission for OMB review; comment request.

SUMMARY: The Acting Deputy Chief Information Officer, Office of the Chief Information Officer, invites comments on the submission for OMB review as required by the Paperwork Reduction Act of 1995.

DATES: Interested persons are invited to submit comments on or before March 12, 1998.

ADDRESSES: Written comments should be addressed to the Office of Information and Regulatory Affairs, Attention: Dan Chenok, Desk Officer, Department of Education, Office of Management and Budget, 725 17th Street, NW., Room 10235, New Executive Office Building, Washington, DC 20503. Requests for copies of the proposed information collection requests should be addressed to Patrick J. Sherrill, Department of Education, 600 Independence Avenue, S.W., Room 5624, Regional Office Building 3, Washington, DC 20202-4651.

FOR FURTHER INFORMATION CONTACT: Patrick J. Sherrill (202) 708-8196. Individuals who use a telecommunications device for the deaf (TDD) may call the Federal Information Relay Service (FIRS) at 1-800-877-8339 between 8 a.m. and 8 p.m., Eastern time, Monday through Friday.

SUPPLEMENTARY INFORMATION: Section 3506 of the Paperwork Reduction Act of 1995 (44 U.S.C. Chapter 35) requires that the Office of Management and Budget (OMB) provide interested Federal agencies and the public an early opportunity to comment on information collection requests. OMB may amend or waive the requirement for public consultation to the extent that public participation in the approval process would defeat the purpose of the

information collection, violate State or Federal law, or substantially interfere with any agency's ability to perform its statutory obligations. The Acting Deputy Chief Information Officer, Office of the Chief Information Officer, publishes this notice containing proposed information collection requests prior to submission of these requests to OMB. Each proposed information collection, grouped by office, contains the following: (1) Type of review requested, e.g., new, revision, extension, existing or reinstatement; (2) Title; (3) Summary of the collection; (4) Description of the need for, and proposed use of, the information; (5) Respondents and frequency of collection; and (6) Reporting and/or Recordkeeping burden. OMB invites public comment at the address specified above. Copies of the requests are available from Patrick J. Sherrill at the address specified above.

Dated: February 4, 1998.

Linda C. Tague

*Acting Deputy Chief Information Officer,
Office of the Chief Information Officer.*

Office of Educational Research and Improvement

Type of Review: New

Title: Research on Charter Schools and Students with Disabilities

Frequency: One-time

Affected Public: Individuals or households; State, local or Tribal Gov't, SEAs or LEAs

Reporting Burden and Recordkeeping:

Responses: 832.

Burden Hours: 1,568.

Abstract: The success to date of the charter schools movement has resulted from the opportunities the schools provide for site-based management free of many regulations, and for instructional and other innovations, parent choice, specialized services to specific populations, and public accountability. This data collection will allow the Department of Education to assemble information on the reasons parents are enrolling students with disabilities in charter schools, the services provided by the schools, the schools' outcome goals, the student outcome measures the schools employ, and the students' success in the schools. Subjects will include educators, parents, and students.

[FR Doc. 98-3235 Filed 2-9-98; 8:45 am]

BILLING CODE 4000-01-P

DEPARTMENT OF EDUCATION

National Committee on Foreign Medical Education and Accreditation

Date and Time: Thursday, March 12, 1998, 8:30 a.m. until 5:30 p.m.

Place: The Embassy Suites Hotel, 1250 22nd Street, N.W., Washington, D.C. 20037, (202) 857-3388. The meeting site is accessible to individuals with disabilities. An individual with a disability who will need an accommodation to participate in the meeting (e.g., interpreting service, assistive listening device, or materials in an alternate format) should notify the contact person listed in this notice at least two weeks before the scheduled meeting date. Although the Department will attempt to meet a request received after that date, the requested accommodations may not be available because of insufficient time to arrange them.

Status: Parts of this meeting will be open to the public. Parts of this meeting will be closed to the public.

Matters to be considered: The standards of accreditation applied to medical schools by a number of foreign countries and the comparability of those standards to the standards of accreditation applied to United States medical schools. Discussions of the standards of accreditation will be held in sessions open to the public. Discussions that focus on specific determinations of comparability are closed to the public in order that each country may be properly notified of the decision.

SUPPLEMENTARY INFORMATION: Pursuant to section 481 of the Higher Education Act of 1965, as amended in 1992 (20 U.S.C. § 1088), the Secretary established within the Department of Education the National Committee on Foreign Medical Education and Accreditation. The Committee's responsibilities are to (1) evaluate the standards of accreditation applied to applicant foreign medical schools; and (2) determine the comparability of those standards to standards for accreditation applied to United States medical schools.

FOR FURTHER INFORMATION CONTACT: Bonnie LeBold, Acting Executive Director, National Committee on Foreign Medical Education and Accreditation, 7th and D Streets, S.W., Room 3082, ROB #3, Washington, D.C. 20202-7563. Telephone: (202) 260-3636. Beginning March 2, 1998, you may call to obtain the identity of the countries whose standards are to be evaluated during this meeting.

Dated: February 3, 1998.

David A. Longanecker,
Assistant Secretary for Postsecondary
Education.

[FR Doc. 98-3300 Filed 2-9-98; 8:45 am]

BILLING CODE 4000-01-M

DEPARTMENT OF EDUCATION

Recognition of Accrediting Agencies, State Agencies for Approval of Public Postsecondary Vocational Education, and State Agencies for Approval of Nurse Education

AGENCY: Department of Education.

ACTION: Request for comments on agencies applying to the Secretary for Renewal of Recognition.

FOR FURTHER INFORMATION CONTACT:

Karen W. Kershenstein, Director, Accreditation and Eligibility Determination Division, U.S. Department of Education, 7th and D Streets, S.W., Room 3915 ROB-3, Washington, DC 20202-5244, telephone: (202) 708-7417. Individuals who use a telecommunications device for the deaf (TDD) may call the Federal Information Relay Service at 1-800-877-8339 between 8 a.m. and 7 p.m., Eastern time, Monday through Friday.

Submission of Third-Party Comments.

The Secretary of Education recognizes, as reliable authorities as to the quality of education offered by institutions or programs within their scope, accrediting agencies and State approval agencies for public postsecondary vocational education and nurse education that meet certain criteria for recognition. A notice published in the Federal Register on December 29, 1997 (Volume 62, page 67632) invited interested third parties to present written comments on agencies scheduled for review at the June 1998 meeting of the National Advisory Committee on Institutional Quality and Integrity (NACIQI). The purpose of this notice is to correct information that was provided in the December 29 notice regarding the names of two agencies that appeared in that notice, to add two other agencies to the list of agencies whose interim reports are to be reviewed at the June meeting, and to delete one agency, the Oklahoma State Board of Vocational and Technical Education, from that list. The correct information is included at the end of this notice. This notice also extends the deadline from February 12, 1998 to March 12, 1998 for interested third parties to present written comments on the two agencies named in this notice

that will be filing interim reports. All other provisions of the December 29, 1997 Federal Register notice remain in effect.

Petitions for Renewal of Recognition

1. Commission on Opticianry Accreditation (requested scope of recognition: the accreditation of two-year programs for the ophthalmic dispenser and one-year programs for the ophthalmic laboratory technician)

2. Commission on Accreditation of Allied Health Education Programs, Board of Directors (requested scope of recognition: the accreditation and preaccreditation ("Candidate status") of educational programs for the allied health occupations of cytotechnologist and electroneurodiagnostic technologist)

Interim Reports

1. Southern Association of Colleges and Schools, Commission on Colleges

2. Oklahoma State Regents for Higher Education (Note: this agency was incorrectly listed as the Oklahoma State Board of Vocational and Technical Education in the December 29, 1997 notice.)

Dated: February 5, 1998.

David A. Longanecker,
Assistant Secretary for Postsecondary
Education.

[FR Doc. 98-3301 Filed 2-9-98; 8:45 am]

BILLING CODE 4000-01-M

DEPARTMENT OF ENERGY

Proposed Subsequent Arrangement Concerning Reciprocal Arrangements for Exchanges of Information and Visits Under the Agreement for Cooperation for the Peaceful Uses of Nuclear Energy Between the Government of the United States and the Government of the People's Republic of China

AGENCY: Office of Arms Control and Nonproliferation, Department of Energy.
ACTION: Notice.

SUMMARY: Notice is hereby given of the intent of the Government of the United States and the Government of the Peoples Republic of China to establish mutually acceptable reciprocal arrangements for exchanges of information and visits to material, facilities, and components subject to the Agreement for Cooperation Between the Government of the United States and the Government of the People's Republic of China concerning the Peaceful Uses of Nuclear Energy, signed July 23, 1985 ("the Agreement").

The framework for executing the proposed exchanges is established in a Memorandum of Understanding (MOU) dated June 23, 1987, which has been initiated by the two Governments and is reproduced at the end of this Notice. The Department of Energy will issue a second Notice of Proposed Subsequent Arrangement, which may contain additional pertinent information, after the Memorandum of Understanding is signed by the two Governments.

SUPPLEMENTARY INFORMATION:

Procedural Background

In order to carry out the 1985 U.S.-China Agreement for Cooperation in the Peaceful Uses of Nuclear Energy, the President is required under P.L. 99-183 to make a certification to Congress on three matters and to submit to Congress a detailed report on China's nonproliferation policies and practices. The President must certify that (A) the reciprocal arrangements made pursuant to Article 8 of the Agreement have been designed to be effective in ensuring that any nuclear materials, facilities or components provided under the Agreement shall be utilized solely for intended peaceful purposes as set forth in the Agreement; (B) the Government of the People's Republic of China has provided additional information concerning its nuclear nonproliferation policies and that, based on this and all other information available to the United States Government, the People's Republic of China is not in violation of paragraph (2) of section 129 of the Atomic Energy Act; and (C) the obligation to consider favorably a request to carry out activities described in Article 5 (2) of the Agreement shall not prejudice the decision of the United States to approve or disapprove such a request.

The President made these certifications on January 12, 1998, and forwarded them to the Congress on January 13, 1998.

House Report 99-382 (November 20, 1985), concerning Public Law 99-183, specified that it was the expectation of the House Committee on Foreign Affairs that at the time the President made these certifications, details concerning the reciprocal arrangements under Article 8 of the Agreement would "be submitted to the Congress for review as a 'subsequent arrangement' under section 131a of the Atomic Energy Act of 1954." That section of the Atomic Energy Act mandates, *inter alia*, that subsequent arrangements are to be issued by the Secretary of Energy or his designee, after obtaining the concurrence of the Department of State and after consultation with the Arms

Control and Disarmament Agency, the Nuclear Regulatory Commission, and the Department of Defense. Notice of any proposed subsequent arrangement must be published in the *Federal Register*, together with a determination by the Secretary of Energy that such arrangement will not be inimical to the common defense and security. A proposed subsequent arrangement may not take effect before fifteen days after publication. (The responsibilities of the Secretary of Energy have been delegated to the Director of the Department's Office of Arms Control and Nonproliferation.)

This Notice announces the intent of the United States Government to enter into reciprocal arrangements for exchanges of information and visits under Article 8 of the Agreement, as specified below. It concludes that the reciprocal arrangements, as provided for in the Agreement and, upon its entry into force, in the U.S.-China Memorandum of Understanding of June 23, 1987, are not inimical to the common defense and security.

Proposed Reciprocal Arrangements

The President has certified that the reciprocal arrangements made pursuant to Article 8 of the Agreement have been designed to be effective in ensuring that any nuclear material, facilities, or components provided under the Agreement shall be utilized solely for the intended peaceful purposes as set forth in the Agreement. The arrangements agreed to by the United States and the People's Republic of China are set forth in the MOU initialed by the two Governments on June 23, 1987.

In assessing the arrangements established under Article 8 of the Agreement, it is important to bear in mind the three main factors considered in their negotiation. These are:

- The fact that China is a nuclear weapon state;
- The nature and scope of cooperation contemplated in the Agreement; and
- The range and extent of activities included under the reciprocal arrangements for exchanges of information and visits mutually agreed between the parties.

China's Status as a Nuclear-Weapon State

China is a nuclear weapon state and possesses dedicated facilities to produce fissile material for its nuclear weapons program. There is, therefore, little if any reason for it to contemplate using its civil nuclear program to support a nuclear weapons purpose. Moreover,

the potential costs of diverting U.S.-supplied civil nuclear material or facilities would be disproportionately high relative to any benefit that could possibly accrue to China. Without doubt such an action would terminate nuclear cooperation by the United States and more generally would do far-reaching damage to U.S.-Chinese relations.

China's nonproliferation credentials would be severely damaged and its credibility and standing in the international community as a whole would be undermined. There has been no evidence to suggest that China has in any way employed its existing nuclear power stations at Qinshan and Daya Bay to support its nuclear weapons program, even though China has modernized and somewhat expanded its nuclear forces since these facilities began operating in 1993 and 1994, respectively.

The Agreement does not require the application of IAEA safeguards on U.S. nuclear exports to China. Neither the Nuclear Non-Proliferation Treaty (NPT) nor U.S. law requires the application of such safeguards on nuclear transfers between nuclear weapon states. NPT safeguards applied by the IAEA are intended to help prevent nuclear proliferation, that is, the spread of nuclear weapons beyond the five acknowledged nuclear weapon states at the time the Treaty was negotiated, a group that include both the United States and China. NPT safeguards are required only on certain equipment and material exported to non-nuclear weapon states. Nor does U.S. law require the application of bilateral safeguards on U.S. exports to a nuclear weapon state. As in the case of the NPT, this reflects the reduced proliferation concerns that apply to transactions with states that already "legally" possess nuclear weapons.

However, the United States as a matter of law requires additional controls and assurances with respect to its nuclear exports. Consequently, the United States requires of all recipients additional bilateral assurances concerning U.S. nuclear transfers. These controls and assurances cover the peaceful use, reprocessing, enrichment, retransfer, physical security, alteration in form or content, and storage of U.S. nuclear exports. These assurances are generally given with reference to specific transactions that are being proposed under Nuclear Regulatory Commission authorization.

Chinese compliance through the Agreement will be confirmed with the reciprocal visits, exchanges, and general information about nuclear fuel cycle activities. In addition, the fact that

violation of the Agreement would cause termination of the U.S. nuclear cooperation with China, is a strong deterrent to misuse of U.S. exports.

Scope of Cooperation

The second factor relevant to assessing the reciprocal arrangements under Article 8 of the Agreement relates to the nature and scope of the cooperation contemplated in that document. The Agreement establishes the basis for cooperation on nuclear nonproliferation and on current and advanced light water nuclear power reactor technologies, including, in part, safety, fuels, and materials; nuclear steam supply systems; irradiation technology; and other areas to which the parties may later agree. The Agreement is thus focused on cooperation in which the most likely transfers are related to nuclear power reactors and nuclear fuel. The only special nuclear material that may be transferred in significant quantities under the Agreement is low-enriched uranium, which is not directly usable for nuclear explosives or other military purposes. Reprocessing of spent fuel subject to the Agreement could occur only with prior U.S. consent. Were the United States ever to consider granting such consent, it would give careful consideration to what additional verification arrangements would be required. The Agreement does not contemplate the transfer of sensitive nuclear technology, facilities, or components. Any such transfer would require amendment to the Agreement and, as in the case of reprocessing spent fuel, would be subject to U.S. approval, which would only be given, if at all, subject to satisfactory provisions for verification of use and disposition.

Furthermore, the Nuclear Regulatory Commission must review any specific export of material or equipment subject to its export approval authority. This will provide added assurance that transfers under the Agreement will be carefully scrutinized to ensure the effectiveness of arrangements to verify that they are used for exclusively peaceful purposes.

Activities Under Article 8

The third factor relevant to assessing the reciprocal arrangements under Article 8 is an evaluation of the extent to which these arrangements can achieve the objectives identified for them under the Agreement. In the case of the NPT, IAEA safeguards are applied in non-nuclear weapon states party to the NPT with the objective of deterring the diversion of a significant quantity of nuclear material by achieving a high probability of detection of such

diversion. For this purpose, quantitative material accountancy, accompanied by containment and surveillance measures, are applied. In the case of the U.S.-China Agreement, the objective is to enable the United States to ensure that the materials and facilities transferred from the United States under the Agreement are used exclusively for peaceful purposes in China.

The arrangements mutually agreed by the parties pursuant to Article 8 of the Agreement are based on well accepted and widely applied principles of verification. They are also consistent with the measures applied by the United States to verify bilateral assurances under other agreements for cooperation. The keys to effective verification are information and access—access to all information deemed relevant to the establishment of a complete inventory of items subject to verification; the ability to secure any additional necessary information; the right to obtain such additional information on site to ensure that the inventory of items is complete; and the right periodically to visit the locations of such material and equipment to ascertain not only the accuracy of the inventory, but that all items on the inventory are being used for agreed peaceful purposes. As noted, the nature of the particular measures employed is a function of the objective to be achieved and will differ from agreement to agreement.

The provisions agreed in the MOU of June 23, 1987, satisfy these criteria. To meet the objective of ensuring that any transferred facilities, materials, or components are not used for any nuclear explosive device, for research on or the development of such devices, or for any military purpose (Article 5(3)), and to provide for exchanges of information and visits to material, facilities and components subject to the agreement (Article 8(2)), the MOU establishes arrangements with adequate scope to provide the United States with full knowledge of items that are subject to the Agreement, where they are located, and how they are being used by the recipient.

Information is provided under the MOU in several ways. When transfers of material, facilities, or components take place, the recipient is required to confirm receipt through diplomatic channels in a specified period of time. Information is also to be provided at the request of either party for the subject material, facilities, and components. To provide a technical basis for evaluating compliance, the information includes isotopic composition, physical form, and quantity of material; locations

where materials, facilities, or components are used or stored; and information on the operation of facilities including, for reactors, loading, and thermal energy generated. Together these stipulations on information access and exchange provide the basis for establishing a comprehensive inventory of items covered by the Agreement and for periodically checking and updating the inventory not only of items transferred, but of material produced through the use of such items.

Access in the form of on-site presence is also provided for and the opportunity during such visits "to observe . . . the utilization and operation" of transferred items will help to confirm information that has been provided regarding inventory and use. The frequency of visits is specified as annually for reactors, and not more than two years between visits for other items. In the case of reactors on the U.S. inventory, visits can be scheduled to coincide with reactor fueling, thus offering an opportunity to learn the most about reactor operation. Since transfers of facilities other than reactors are not contemplated by the Agreement, this approach provides the basis for an effective verification arrangement.

Finally, the MOU includes agreement that, "When either party identifies special circumstances, the parties shall consult . . . for the purpose of making mutually acceptable arrangements for the addition or reduction of visits . . . to ensure that the objectives of Article 8(2) are fulfilled." It further provides that, "Either party may request a revision of these arrangements including the frequency, occasion, or content of visits at any time. . . ." The arrangements call for access in the form of visits, rather than the inspections that form a part of IAEA safeguards. In addition, the routine frequency of access to reactors is less than under IAEA safeguards practice. However, it must be recalled that as a nuclear weapon state, China is not required by law to place U.S. nuclear exports under IAEA safeguards and, because China's incentive to misuse U.S. supplies for nuclear explosive purposes is extremely low, the need for visits more often than annually is absent. Moreover, the wording in the MOU concerning special circumstances, or the revision of arrangements regarding visits, leaves the door open to gaining additional access when uncertainties exist for which early resolution is important to continued confidence in the cooperation Agreement.

A summary assessment of the peaceful use assurances was previously provided by the Executive Branch to the

Congress in 1985. That summary includes the following paragraph:

The proposed agreement with China contains provisions that assure that nuclear material, facilities and components supplied by the United States will not be misused. In addition to articles 8(2) and 5(2), which are discussed in this memorandum, there are commitments that these items will not be used for any military or explosive purpose, will not be retransferred without U.S. consent, and will be subject to agreed levels of physical security. All these provisions will continue in effect as long as the item in question remains in China, even if the agreement itself expires. Moreover, the agreement expressly excludes cooperation in sensitive technologies, nor does it in any way require that technology of military or strategic significance be transferred. While it provides a framework for potential U.S. nuclear exports, it does not commit the United States to export any item. Taken together, these provisions establish a regime for nuclear cooperation that is suitably stringent and appropriate for reciprocal dealing with a nuclear-weapons state.

In his letter of January 12, 1998, transmitting the certifications required by P.L. 99-183 to the Speaker of the House of Representatives, the President of the Senate, and the Chairmen of the Senate Committee on Foreign Relations, and the House Committee on International Relations, the President declared, with respect to the reciprocal arrangements under Article 8 of the Agreement:

* * * These arrangements will provide the United States with the right to obtain all the information necessary to maintain an inventory of the items subject to the Agreement. This will include information on the operation of facilities subject to the Agreement, the isotopic composition, physical form and quantity of material subject to the Agreement and the places where items subject to the Agreement are used or kept. The arrangements also provide the United States with the right to confirm through on-site visits the use of all items subject to the Agreement. Finally, the arrangements apply as long as the provisions of Article 8(2) of the Agreement continue in effect, that is, as long as items subject to the Agreement remain in China's territory or under its jurisdiction or control. My determination that these arrangements have been designed to be effective in ensuring that items provided under the Agreement are utilized for intended peaceful purposes is based on consideration of a range of factors, including the limited scope of nuclear cooperation permitted under the Agreement, U.S. export-control procedures that will apply to any transfers to China under the Agreement, the fact that the People's Republic of China is a nuclear-weapon state and that the safeguards of the IAEA or their equivalent are not required by the Atomic Energy Act for agreements for cooperation with nuclear weapon states.

In light of these considerations, I have determined that the reciprocal arrangements, as provided in the Agreement and, upon its entry into force, in the U.S.-China Memorandum of Understanding of June 23, 1997, are not inimical to the common defense and security.

The text of the U.S.-China Memorandum of Understanding of June 23, 1987, follows.

Memorandum of Understanding

The Government of the United States of America and the Government of the People's Republic of China (the "parties").

Desiring to implement the Agreement for Cooperation between the Government of the United States of America and the Government of the People's Republic of China Concerning Peaceful Uses of Nuclear Energy, signed July 23, 1985, and entered into force December 30, 1985 (the "Agreement"), on the basis of mutual respect for sovereignty, non-interference in each other's internal affairs, equality and mutual benefit, and Desiring to exchange experience, strengthen technical cooperation between the parties, ensure that the provisions of the Agreement are effectively carried out, and enhance a stable, reliable, and predictable nuclear cooperation relationship,

Have established the following arrangements:

1. Each party shall invite personnel designated by the other party to visit the material, facilities and components subject to the Agreement, affording them the opportunity to observe and exchange views on, and share technical experience in, the utilization or operation of such items. Opportunities to visit shall be accorded annually to reactors including their auxiliary storage pools for the fuel. Such annual visits shall be arranged at the time of reactor fueling if it occurs. Opportunities to visit all other items shall not be less often than every two years. When either party identifies special circumstances, the parties shall consult, at the request of either party, for the purpose of making mutually acceptable arrangements for the addition or reduction of visits under such circumstances in order to ensure that the objectives of Article 8(2) are fulfilled.

2. When material, facilities or components are transferred pursuant to the Agreement, the recipient party shall confirm receipt to the supplier party through diplomatic channels within 30 days after the arrival of the material, facilities or components in the territory

of the recipient party. At the request of either party, the parties shall exchange information on the material, facilities and components subject to the Agreement. Such information shall include the isotopic composition, physical form, and quantity of the material, and places where the material, facilities or components are used or kept. It shall also include information on the operation of the facilities subject to the Agreement which in the case of a reactor shall cover thermal energy generated and loading. The parties shall seek to resolve any discrepancies through diplomatic channels. The information shall be treated as confidential.

The above arrangements fulfill the requirements of Article 8(2) of the Agreement for the types of peaceful nuclear activities pursuant to the Agreement that each party had planned as of the date of entry into force of the Agreement. These arrangements shall enter into force upon signature and shall remain in force so long as the provisions of Article 8(2) continue in effect. Either party may request a revision of these arrangements, including the frequency, occasion or content of visits, at any time; any revision shall be made by mutual agreement.

Done at this day of _____, 1987 in the English and Chinese languages, both equally authentic.

FOR THE GOVERNMENT OF THE UNITED STATES OF AMERICA:

FOR THE GOVERNMENT OF THE PEOPLE'S REPUBLIC OF CHINA:

Dated: February 3, 1998.

For the Department of Energy.

Leonard S. Spector,
Director, Office of Arms Control and Nonproliferation.

[FR Doc. 98-3308 Filed 2-9-98; 8:45 am]

BILLING CODE 6450-01-P

DEPARTMENT OF ENERGY

Environmental Management Site-Specific Advisory Board, Nevada Test Site

AGENCY: Department of Energy.

ACTION: Notice of Open Meeting.

SUMMARY: Pursuant to the provisions of the Federal Advisory Committee Act (Pub. L. 92-463, 86 Stat. 770) notice is hereby given of the following Advisory Committee meeting: Environmental Management Site-Specific Advisory Board (EM SSAB), Nevada Test Site.

DATES: Wednesday, March 4, 1998: 5:30 p.m.-9:00 p.m.

ADDRESSES: U.S. Department of Energy, Nevada Support Facility, Great Basin

Room, 232 Energy Way, North Las Vegas, Nevada.

FOR FURTHER INFORMATION CONTACT: Kevin Rohrer, U.S. Department of Energy, Office of Environmental Management, P.O. Box 98518, Las Vegas, Nevada 89193-8513, phone: 702-295-0197.

SUPPLEMENTARY INFORMATION:

Purpose of the Board: The purpose of the Advisory Board is to make recommendations to DOE and its regulators in the areas of environmental restoration, waste management, and related activities.

Tentative Agenda

5:30 p.m.—Call to Order
5:40 p.m.—Presentations
7:00 p.m.—Public Comment/Questions
7:30 p.m.—Break
7:45 p.m.—Review Action Items
8:00 p.m.—Approve Meeting Minutes
8:10 p.m.—Committee Reports
8:45 p.m.—Public Comment
9:00 p.m.—Adjourn

Copies of the final agenda will be available at the meeting.

Public Participation: The meeting is open to the public. Written statements may be filed with the Committee either before or after the meeting. Individuals who wish to make oral statements pertaining to agenda items should contact Kevin Rohrer, at the telephone number listed above. Requests must be received 5 days prior to the meeting and reasonable provision will be made to include the presentation in the agenda. The Designated Federal Official is empowered to conduct the meeting in a fashion that will facilitate the orderly conduct of business.

Minutes: The minutes of this meeting will be available for public review and copying at the Freedom of Information Public Reading Room, 1E-190, Forrestal Building, 1000 Independence Avenue, SW, Washington, DC 20585 between 9:00 a.m. and 4 p.m., Monday-Friday, except Federal holidays. Minutes will also be available by writing to Kevin Rohrer at the address listed above.

Issued at Washington, DC, on February 3, 1998.

Rachel Samuel,
Deputy Advisory Committee Management Officer.

[FR Doc. 98-3310 Filed 2-9-98; 8:45 am]

BILLING CODE 6450-01-P

DEPARTMENT OF ENERGY

Secretary of Energy Advisory Board; Notice of Open Meeting

AGENCY: Department of Energy.

SUMMARY: Consistent with the provisions of the Federal Advisory Committee Act (Pub. L. 92-463, 86 Stat. 770), notice is hereby given of the following advisory committee meeting:
Name: Secretary of Energy Advisory Board—Laboratory Operations Board
Date and Time: Tuesday, February 24, 1998, 9:30 A.M.—3:30 P.M.
Place: Georgetown University Conference Center, Salon H, 3800 Reservoir Road, NW, Washington, DC 20057.

FOR FURTHER INFORMATION CONTACT: Richard C. Burrow, Secretary of Energy Advisory Board (AB-1), US Department of Energy, 1000 Independence Avenue, SW, Washington, D.C. 20585, (202) 586-1709.

SUPPLEMENTARY INFORMATION: The purpose of the Laboratory Operations Board is to provide advice to the Secretary of Energy Advisory Board regarding the strategic direction of the Department's laboratories, the coordination of budget and policy issues affecting laboratory operations, and the reduction of unnecessary and counterproductive management burdens on the laboratories. The Laboratory Operations Board's goal is to facilitate the productive and cost-effective utilization of the Department's laboratory system and the application of best business practices.

Tentative Agenda

Tuesday, February 24, 1998

- 9:30–10:00 A.M.—Opening Remarks—
 Co-Chairs: Under Secretary Dr. Ernest Moniz and Dr. John McTague
 10:00–11:00 A.M.—Status Report on Laboratory Operations Board Activities
 11:00–12:00 A.M.—Discussion of "Roadmap" Planning Activities
 12:00–1:00 P.M.—Lunch
 1:00–2:00 P.M.—Continuation of the Discussion of "Roadmap" Planning Activities
 2:00–3:00 P.M.—Presentation on Department of Energy Contracting Policies & Practices
 3:00–3:30 P.M.—Public Comment Period
 3:30 P.M.—Adjourn

This tentative agenda is subject to change. A final agenda will be available at the meeting.

Public Participation

The Chairman of the Laboratory Operations Board is empowered to conduct the meeting in a way which will, in the Chairman's judgment, facilitate the orderly conduct of business. During its meeting in Washington, D.C., the Laboratory

Operations Board welcomes public comment. Members of the public will be heard in the order in which they sign up at the beginning of the meeting. The Laboratory Operations Board will make every effort to hear the views of all interested parties. Written comments may be submitted to Skila Harris, Executive Director, Secretary of Energy Advisory Board, AB-1, US Department of Energy, 1000 Independence Avenue, SW, Washington, DC 20585. This notice is being published less than 15 days before the date of the meeting due to programmatic issues that had to be resolved prior to publication.

Minutes

Minutes and a transcript of the meeting will be available for public review and copying approximately 30 days following the meeting at the Freedom of Information Public Reading Room, 1E-190 Forrestal Building, 1000 Independence Avenue, SW, Washington, D.C., between 9:00 A.M. and 4:00 P.M., Monday through Friday except Federal holidays. Information on the Laboratory Operations Board may also be found at the Secretary of Energy Advisory Board's web site, located at <http://www.hr.doe.gov/seab>.

Issued at Washington, DC, on February 4, 1998.

Rachel M. Samuel,
 Deputy Advisory Committee Management Officer.
 [FR Doc. 98-3309 Filed 2-9-98; 8:45 am]
 BILLING CODE 6450-01-P

DEPARTMENT OF ENERGY

Federal Energy Regulatory Commission

[Docket No. OA96-154-002]

Central Illinois Public Service Company; Notice of Filing

February 4, 1998.

Take notice that on September 15, 1997, Central Illinois Public Service Company tendered for filing its refund report in the above-referenced docket.

Any person desiring to be heard or to protest said filing should file a motion to intervene or protest with the Federal Energy Regulatory Commission, 888 First Street, N.E., Washington, D.C. 20426, in accordance with Rules 211 and 214 of the Commission's Rules of Practice and Procedure (18 CFR 385.211 and 18 CFR 385.214). All such motions or protests should be filed on or before February 17, 1998. Protests will be considered by the Commission in determining the appropriate action to be taken, but will not serve to make

protestants parties to the proceeding. Any person wishing to become a party must file a motion to intervene. Copies of this filing are on file with the Commission and are available for public inspection.

David P. Boergers,
 Acting Secretary.

[FR Doc. 98-3252 Filed 2-9-98; 8:45 am]
 BILLING CODE 6717-01-M

DEPARTMENT OF ENERGY

Federal Energy Regulatory Commission

[Docket No. RP98-125-000]

Columbia Gulf Transmission Company; Notice of Proposed Changes in FERC Gas Tariff

February 4, 1998.

Take notice that on January 30, 1998, Columbia Gulf Transmission Company (Columbia Gulf) tendered for filing as part of its FERC Gas Tariff, Second Revised Volume No. 1, the following revised sheets, bearing a proposed effective date of March 2, 1998:

Sixth Revised Sheet No. 129
 Fourth Revised Sheet No. 130

Columbia Gulf states that, the above referenced tariff sheets are being tendered for filing to correct the General Terms and Conditions (GTC), Section 1, of Columbia Gulf's Second Revised Volume No. 1 Tariff to incorporate the term "Offsystem-Onshore Zone". Columbia Gulf previously filed to incorporate this term in its tariff filing under Docket No. RP97-52-000 filed on October 31, 1996, (Third Revised Sheet No. 129). Subsequent Commission orders in Docket No. RP97-52, issued November 27, 1996 (77 FERC ¶ 61,255) (suspension order), and June 16, 1997 (79 FERC ¶ 61,351) accepted this and certain other tariff sheets listed in Appendix B of the November 27, 1996 order to become effective May 1, 1997.

During the suspension time period, Columbia Gulf filed additional changes to Section 1 of the GTC to incorporate the Gas Industry Standards Board (GISB) tariff requirements. It has come to Columbia Gulf's attention that the definition for "Offsystem-Onshore Zone" has been inadvertently omitted from Section 1 of the GTC and is, therefore, by the instant filing, placing that definition back into the GTC as Section 1.23 and thus requiring the renumbering of the remaining items in Section 1.

Columbia Gulf states that copies of its filing have been mailed to all firm

customers, interruptible customers, affected state commissions.

Any person desiring to be heard or to protest said filing should file a motion to intervene or protest with the Federal Energy Regulatory Commission, 888 First Street, N.E., Washington, D.C. 20426, in accordance with Sections 385.211 and 385.214 of the Commission's Rules and Regulations. All such motions or protests must be filed as provided in Section 154.210 of the Commission's Regulations. Protests will be considered by the Commission in determining the appropriate action to be taken, but will not serve to make protestants parties to the proceeding. Any person wishing to become a party must file a motion to intervene. Copies of this filing are on file with the Commission and are available for public inspection in the Public Reference Room.

David P. Boergers,

Acting Secretary.

[FR Doc. 98-3245 Filed 2-9-98; 8:45 am]

BILLING CODE 6717-01-M

DEPARTMENT OF ENERGY

Federal Energy Regulatory Commission

[Docket Nos. RP97-287-010 and CP97-667-001]

El Paso Natural Gas Company; Notice of Technical Conference

February 4, 1998.

On January 23, 1998, the Commission issued an order in Docket No. RP97-287-010 requiring that a technical conference be convened to address El Paso Natural Gas Company's proposed transportation contracts with Natural Gas Clearing House. The technical conference will afford a convenient opportunity to also address an issue in Docket No. CP97-667-001 as to the actual or potential role of Southern California Gas Company as a "gatekeeper" at the Topock delivery point.

The technical conference will convene at 10:00 a.m. on March 3, 1998, at the Federal Energy Regulatory Commission, 888 First Street, N.E., Washington, DC, in a room to be designated at that time.

David P. Boergers,

Acting Secretary.

[FR Doc. 98-3249 Filed 2-9-98; 8:45 am]

BILLING CODE 6717-01-M

DEPARTMENT OF ENERGY

Federal Energy Regulatory Commission

Mid Louisiana Gas Company; Notice of Proposed Changes in FERC Gas Tariff

February 4, 1998.

Take notice that on January 30, 1998, Mid Louisiana Gas Company (Mid Louisiana) tendered for filing as part of its FERC Gas Tariff, Third Revised Volume No. 1, the following tariff sheets with an effective date of March 1, 1998:

Original Sheet No. 0
Third Revised Sheet No. 86
Fourth Revised Sheet No. 130
Seventh Revised Sheet No. 131
Second Revised Sheet No. 203
First Revised Sheet No. 212
First Revised Sheet No. 213
First Revised Sheet No. 222
First Revised Sheet No. 223
First Revised Sheet No. 232
First Revised Sheet No. 233
First Revised Sheet No. 243
First Revised Sheet No. 275
First Revised Sheet No. 276

Mid Louisiana states that the purpose of the filing of the Revised Tariff Sheet(s) is to update its tariff to reflect recent changes in shared personnel and facilities.

Pursuant to Section 154.7(a)(7) of the Commission's Regulations, Mid Louisiana respectfully requests waiver of any requirement of the Regulations in order to permit the tendered tariff sheet to become effective March 1, 1998, as submitted.

Any person desiring to be heard or to protest said filing should file a motion to intervene or protest with the Federal Energy Regulatory Commission, 888 First Street, N.E., Washington, D.C. 20426, in accordance with Sections 385.214 and 385.211 of the Commission's Rules and Regulations. All such motions or protests should be filed in accordance with Section 154.210 of the Commission's Regulations. Protests will be considered by the Commission in determining the appropriate action to be taken, but will not serve to make protestants parties to the proceeding. Any person wishing to become a party must file a motion to intervene. Copies of this filing are on file with the Commission and are available for public inspection in the Public Reference Room.

David P. Boergers,

Acting Secretary.

[FR Doc. 98-3244 Filed 2-9-98; 8:45 am]

BILLING CODE 6717-01-M

DEPARTMENT OF ENERGY

Federal Energy Regulatory Commission

[Docket No. CP98-210-000]

NorAm Gas Transmission Company; Notice of Request Under Blanket Authorization

February 4, 1998.

Take notice that on January 30, 1998, NorAm Gas Transmission Company (Applicant) 1600 Smith Street, Houston, Texas 77002 filed under Sections 157.205 and 157.216 of the Commission's Regulations to abandon facilities in Louisiana, all as more fully set forth in the request which is on file with the Commission and open to public inspections.

Applicant proposes abandon by sale 15,350 feet of 4-inch pipe, comprising Line AM-3, in Caddo, Parish Louisiana to Arkla, a distribution division of NorAm Energy Corp. (Arkla). Arkla will buy the facilities at their net-book value. Arkla will use the AM-3 Line as part of its Ida, Louisiana distribution system.

Any person or the Commission's staff may, within 45 days after issuance of the instant notice by the Commission, file pursuant to Rule 214 of the Commission's Procedural Rules (18 CFR 385.214) a motion to intervene or notice of intervention and pursuant to Section 157.205 of the Regulations under the Natural Gas Act (18 CFR 157.205) a protest to the request. If no protest is filed within the time allowed therefore, the proposed activity shall be deemed to be authorized effective the day after the time allowed for filing a protest. If a protest is filed and not withdrawn within 30 days after the time allowed for filing a protest, the instant request shall be treated as an application for authorization pursuant to Section 7 of the Natural Gas Act.

David P. Boergers,

Acting Secretary.

[FR Doc. 98-3241 Filed 2-9-98; 8:45 am]

BILLING CODE 6717-01-M

DEPARTMENT OF ENERGY

Federal Energy Regulatory Commission

[Docket No. RP98-127-000]

Northern Natural Gas Company; Notice of Proposed Changes in FERC Gas Tariff

February 4, 1998.

Take notice that on January 30, 1998, Northern Natural Gas Company (Northern), tendered for filing changes

in its FERC Gas Tariff, Fifth Revised Volume No. 1 and Volume No. 2, the following tariff sheets, proposed to be effective March 1, 1998:

Fifth Revised Volume No. 1
42 Revised Sheet No. 50
42 Revised Sheet No. 51
15 Revised Sheet No. 52
39 Revised Sheet No. 53
14 Revised Sheet No. 59
16 Revised Sheet No. 60
Original Volume No. 2
154 Revised Sheet No. 1C
29 Revised Sheet No. 1C.a

In this filing, Northern is seeking to remove the surcharges relating to take-or-pay, pricing or other contract provisions, and buyout, buydown or reformation costs pursuant to the Commission's Order No. 528.

Northern further states that copies of the filing have been mailed to each of its customers and interested State Commissions.

Any Person desiring to be heard or to protest said filing should file a petition to intervene or protest with the Federal Energy Regulatory Commission, 888 First Street N.W. Washington, D.C. 20426, in accordance with Sections 385.214 and 385.211 of the Commission's Regulations. Protests will be considered by the Commission in determining the appropriate action to be taken, but will not serve to make protestants parties to the proceeding. Any person wishing to become a party must file a motion to intervene. Copies of this filing are on file with the Commission and are available for public inspection.

David P. Boergers,
Acting Secretary.

[FR Doc. 98-3247 Filed 2-9-98; 8:45 am]
BILLING CODE 6717-01-M

DEPARTMENT OF ENERGY

Federal Energy Regulatory Commission

[Docket No. GT98-17-000]

PG&E Gas Transmission, Northwest Corporation; Notice of Tariff Filing to Reflect Change in Corporate

February 4, 1998.

Take notice that on January 30, 1998, PG&E Gas Transmission, Northwest Corporation (PG&E GT-NW) tendered for filing as part of its FERC Gas Tariff, First Revised Volume No. 1-A certain tariff sheets, to be effective February 2, 1998, to reflect the change in its corporate name from Pacific Gas Transmission Company to PG&E Gas Transmission, Northwest Corporation.

PG&E GT-NW further states that a copy of this filing has been served on PG&E GT-NW's jurisdictional customers and interested state regulatory agencies.

Any person desiring to be heard or protest said filing should file a motion to intervene or protest with the Federal Energy Regulatory Commission, 888 First Street, N.E., Washington, D.C. 20426, in accordance with Sections 385.214 and 385.211 of the Commission's Rules of Practice and Procedure. All such motions or protests must be filed as provided in Section 154.210 of the Commission's Regulations. Protests will be considered by the Commission in determining the appropriate action to be taken, but will not serve to make protestants parties to the proceeding. Any person wishing to become a party must file a motion to intervene. Copies of this filing are on file with the Commission and are available for public inspection in the Public Reference Room.

David P. Boergers,
Acting Secretary.

[FR Doc. 98-3243 Filed 2-9-98; 8:45 am]
BILLING CODE 6717-01-M

DEPARTMENT OF ENERGY

Federal Energy Regulatory Commission

[Docket No. RP98-126-000]

Texas Gas Transmission Corporation; Notice of Filing of Refund Report

February 4, 1998.

Take notice that on January 30, 1998, Texas Gas Transmission Corporation (Texas Gas) tendered for filing a refund report detailing a January 8, 1998, Transportation Cost Adjustment (TCA) Tracker refund of \$1,353,152.86.

Texas Gas states that the refund reflects the net credit balances in its TCA deferral accounts at October 31, 1997, when its TCA Tracker was terminated.

Texas Gas states that copies of this filing have been served upon Texas Gas's customers receiving refunds and interested state commissions.

Any person desiring to be heard or to protest said filing should file a motion to intervene or protest with the Federal Energy Regulatory Commission, 888 First Street, N.E., Washington, D.C. 20426, in accordance with Sections 385.211 and 385.214 of the Commission's Rules and Regulations. All such motions or protests should be filed on or before February 11, 1998. Protests will be considered by the Commission in determining the

appropriate action to be taken, but will not serve to make protestants parties to the proceeding. Any person wishing to become a party to the proceeding must file a motion to intervene. Copies of this filing are on file with the Commission and are available for public inspection in the Public Reference Room.

David P. Boergers,
Acting Secretary.

[FR Doc. 98-3246 Filed 2-9-98; 8:45 am]
BILLING CODE 6717-01-M

DEPARTMENT OF ENERGY

Federal Energy Regulatory Commission

[Docket No. OA96-50-000]

Union Electric Company; Notice of Filing

February 4, 1998.

Take notice that on August 29, 1997, Union Electric Company tendered for filing its compliance filing in the above-referenced docket.

Any person desiring to be heard or to protest said filing should file a motion to intervene or protest with the Federal Energy Regulatory Commission, 888 First Street, N.E., Washington, D.C. 20426, in accordance with Rules 211 and 214 of the Commission's Rules of Practice and Procedure (18 CFR 385.211 and 18 CFR 385.214). All such motions or protests should be filed on or before February 13, 1998. Protests will be considered by the Commission in determining the appropriate action to be taken, but will not serve to make protestants parties to the proceeding. Any person wishing to become a party must file a motion to intervene. Copies of this filing are on file with the Commission and are available for public inspection.

David P. Boergers,
Acting Secretary.

[FR Doc. 98-3251 Filed 2-9-98; 8:45 am]
BILLING CODE 6717-01-M

DEPARTMENT OF ENERGY

Federal Energy Regulatory Commission

[Project No. UL 94-1—Maine Upper and Middle Dam Storage Project]

Union Water Power Company; Notice of Meeting

February 4, 1998.

Union Water Power Company (UWP) is the Applicant for the Upper and Middle Dam Storage Project, which is located in the headwaters of the

Androscoggin River, in Oxford and Franklin Counties, Maine. UWP has requested a meeting with the Federal Energy Regulatory Commission staff to discuss the applicant-prepared environmental assessment process for the Upper and Middle Dam Storage Project (Project No. UL 94-1). A meeting has been scheduled for Tuesday, February 17, 1998, which will begin at 10:00 a.m. The meeting will be held in room 6J-04 at the Federal Energy Regulatory Commission, 888 First Street, N.E., Washington, D.C. 20426.

If you have any question concerning this matter, please contact Ms. Patti Leppert-Slack at (202) 219-2767.

David P. Boergers,
Acting Secretary.

[FR Doc. 98-3250 Filed 2-9-98; 8:45 am]

BILLING CODE 6717-01-M

DEPARTMENT OF ENERGY

Federal Energy Regulatory Commission

[Docket No. CP98-208-000]

Williston Basin Interstate Pipeline Company; Notice of Request Under Blanket Authorization

February 4, 1998.

Take notice that on January 28, 1998, Williston Basin Interstate Pipeline Company (Williston Basin), 200 North Third Street, Suite 300, Bismarck, North Dakota 58501, filed in Docket No. CP98-208-000 a request pursuant to Sections 157.205 and 157.216 of the Commission's Regulations under the Natural Gas Act (18 CFR 157.205 and 157.216) for permission and approval to abandon a 3-inch meter run and appurtenant facilities located at the Recluse Station in Campbell County, Wyoming. Williston Basin makes such request under its blanket certificate issued in Docket Nos. CP82-487-000, *et al.*, pursuant to Section 7 of the Natural Gas Act, all as more fully set forth in the request on file with the Commission and open to public inspection.

Williston Basin is seeking authority to abandon the above ground 3-inch meter run and appurtenant facilities, which include a 5 x 7 foot skid-mounted building, orifice meter and miscellaneous gauges, station piping and valves, which Williston Basin avers are not used or useful. In 1981, Montana-Dakota Utilities Co. installed the 3-inch meter run and appurtenant facilities at the Recluse Station to deliver gas to a gas pipeline company. Williston Basin was authorized to acquire and operate those facilities pursuant to the Commission's Order

issued in Docket Nos. CP82-487-000, *et al.*

It is stated that the abandonment of the proposed facilities, all of which are located on Williston Basin's existing right-of-way, will not affect Williston Basin's peak day or annual transportation, because there will be no abandonment of service to its existing customers, since service will continue to be provided through existing facilities at the site.

Any person or the Commission's staff may, within 45 days after issuance of the instant notice by the Commission, file pursuant to Rule 214 of the Commission's Procedural Rules (18 CFR 385.214) a motion to intervene or notice of intervention and pursuant to Section 157.205 of the Regulations under the Natural Gas Act (18 CFR 157.205) a protest to the request. If no protest is filed within the time allowed therefor, the proposed activity shall be deemed to be authorized effective the day after the time allowed for filing a protest. If a protest is filed and not withdrawn within 30 days after the time allowed for filing a protest, the instant request shall be treated as an application for authorization pursuant to Section 7 of the Natural Gas Act.

David P. Boergers,
Acting Secretary.

[FR Doc. 98-3240 Filed 2-9-98; 8:45 am]

BILLING CODE 6717-01-M

DEPARTMENT OF ENERGY

Federal Energy Regulatory Commission

[Docket No. GT98-16-000]

Williston Basin Interstate Pipeline Company; Notice of Filing

February 4, 1998.

Take notice that on February 2, 1998, Williston Basin Interstate Pipeline Company (Williston Basin), tendered for filing as part of its FERC Gas Tariff, Second Revised Volume No. 1, the following revised tariff sheets to become effective February 1, 1998:

Tenth Revised Sheet No. 776
Eleventh Revised Sheet No. 777
Twenty-first Revised Sheet No. 831
Twenty-second Revised Sheet No. 832
Twenty-second Revised Sheet No. 833

Williston Basin states that the revised tariff sheets are being filed simply to update its Master Receipt/Delivery Point List.

Any person desiring to be heard or to protest this filing should file a motion to intervene or protest with the Federal Energy Regulatory Commission, 888

First Street, NE., Washington, DC 20426, in accordance with Sections 385.214 and 385.211 of the Commission's Rules and Regulations. All such motions or protests must be filed in accordance with Section 154.210 of the Commission's Regulations. Protests will be considered by the Commission in determining the appropriate action to be taken, but will not serve to make protestants parties to the proceeding. Any person wishing to become a party must file a motion to intervene. Copies of this filing are on file with the Commission and are available for public inspection in the Public Reference Room.

David P. Boergers,
Acting Secretary.

[FR Doc. 98-3242 Filed 2-9-98; 8:45 am]

BILLING CODE 6717-01-M

DEPARTMENT OF ENERGY

Federal Energy Regulatory Commission

[Docket No. RP97-375-000]

Wyoming Interstate Company, Ltd., Notice Rescheduling an Informal Settlement Conference

February 4, 1998.

Take notice that the informal settlement conference previously scheduled for February 5, 1998, has been rescheduled for February 18, 1998 at 10:00 a.m. The settlement conference will be held at the offices of the Federal Energy Regulatory Commission, 888 First Street, N.E., Washington, D.C. 20426, for the purpose of exploring the possible settlement of the above-referenced docket.

Any party, as defined by 18 CFR 385.102(c), or any participant, as defined by 18 CFR 385.102(b), is invited to attend. Persons wishing to become a party must move to intervene and receive intervenor status pursuant to the Commission's regulations (18 CFR 385.214).

For additional information, please contact Arnold Meltz at (202) 208-2161 or John Roddy at (202) 208-0053.

David P. Boergers,
Acting Secretary.

[FR Doc. 98-3248 Filed 2-9-98; 8:45 am]

BILLING CODE 6717-01-M

DEPARTMENT OF ENERGY**Federal Energy Regulatory Commission**

[Docket No. ER97-3200-003, et al.]

Montaup Electric Co., et al.; Electric Rate and Corporate Regulation Filings

February 4, 1998.

Take notice that the following filings have been made with the Commission:

1. Montaup Electric Company

[Docket No. ER97-3200-003]

Take notice that on January 20, 1998, Montaup Electric Company tendered for filing its compliance filing in the above-referenced docket.

Comment date: February 18, 1998, in accordance with Standard Paragraph E at the end of this notice.

2. New England Power Company

[Docket No. ER98-466-001]

Take notice that on January 16, 1998, New England Power Company tendered for filing its proposed accounting for stranded costs and related revenues.

Comment date: February 18, 1998, in accordance with Standard Paragraph E at the end of this notice.

3. Carolina Power & Light Company

[Docket No. ER98-651-001]

Take notice that on January 27, 1998, Carolina Power & Light Company submitted its compliance filing as required by the Commission's January 12, 1998, order in this proceeding.

Comment date: February 18, 1998, in accordance with Standard Paragraph E at the end of this notice.

4. Cinergy Services, Inc.

[Docket No. ER98-1394-000]

Take notice that on January 12, 1998, Cinergy Services, Inc. (Cinergy), tendered for filing on behalf of its operating companies, The Cincinnati Gas & Electric Company (CG&E), and PSI Energy, Inc. (PSI), an Interchange Agreement, dated December 1, 1997, between Cinergy, CG&E, PSI and MIECO Inc., (MIECO).

The Interchange Agreement provides for the following service between Cinergy and MIECO:

1. Exhibit A—Power Sales by MIECO
2. Exhibit B—Power Sales by Cinergy

Cinergy and MIECO have requested an effective date of one day after this initial filing of the Interchange Agreement.

Copies of the filing were served on MIECO Inc., the Energy Commission of California, the Kentucky Public Service Commission, the Public Utilities

Commission of Ohio and the Indiana Utility Regulatory Commission.

Comment date: February 17, 1998, in accordance with Standard Paragraph E at the end of this notice.

5. FirstEnergy System

[Docket No. ER98-1395-000]

Take notice that on January 12, 1998, FirstEnergy System filed Service Agreements to provide Non-firm Point-to-Point Transmission Service for Allegheny Power Service Corporation, American Electric Power Service Corporation, American Municipal-Ohio, Ohio Valley Electric Corporation, PacifiCorp Power Marketing, Incorporated, Plum Street Energy Marketing, Incorporated, and Williams Energy Services Company, the Transmission Customers. Services are being provided under the FirstEnergy System Open Access Transmission Tariff submitted for filing by the Federal Energy Regulatory Commission in Docket No. ER97-412-000. The proposed effective dates under the Service Agreements is January 1, 1998.

Comment date: February 17, 1998, in accordance with Standard Paragraph E at the end of this notice.

6. Central Hudson Gas & Electric Corporation

[Docket No. ER98-1400-000]

Take notice that on January 12, 1998, Central Hudson Gas & Electric Corporation tendered for filing its Transaction Report for Quarter ended December 31, 1997.

Comment date: February 18, 1998, in accordance with Standard Paragraph E at the end of this notice.

7. Duquesne Light Company

[Docket No. ER98-1405-000]

Take notice that on January 12, 1998, Duquesne Light Company (DLC), filed a Service Agreement dated January 7, 1998, with Western Resources, Inc., under DLC's FERC Coordination Sales Tariff (Tariff). The Service Agreement adds Western Resources, Inc., as a customer under the Tariff. DLC requests an effective date of January 7, 1998, for the Service Agreement.

Comment date: February 17, 1998, in accordance with Standard Paragraph E at the end of this notice.

8. Houston Lighting & Power Company

[Docket No. ER98-1406-000]

Take notice that on January 12, 1998, Houston Lighting & Power Company (HL&P), submitted for filing a notice of cancellation of a transmission service agreement with Tenneco Energy Marketing Company (Tenneco), under

HL&P's tariff for transmission service to, from and over certain HVDC Interconnections.

HL&P states that a copy of the filing has been served on all affected customers.

Comment date: February 17, 1998, in accordance with Standard Paragraph E at the end of this notice.

9. Duke/Louis Dreyfus Energy Services (New England) L.L.C.

[Docket No. ER98-1407-000]

Take notice that on January 9, 1998, Duke/Louis Dreyfus Energy Services (New England) L.L.C., tendered for filing a Notice of Termination of Electric Rate Schedule No. 1 and supplements, with a proposed effective date of December 24, 1997.

Comment date: February 17, 1998, in accordance with Standard Paragraph E at the end of this notice.

10. Metropolitan Edison Company and Pennsylvania Electric Company

[Docket No. ER98-1408-000]

Take notice that on January 5, 1998, Metropolitan Edison Company and Pennsylvania Electric Company (d/b/a GPU Energy) filed executed Retail Transmission Service Agency Agreements between GPU Energy and (1) MidCon Gas Services Corp., dated December 18, 1997, and (2) Eastern Power Distribution, Inc., dated December 5, 1997.

GPU Energy requests a waiver of the Commission's notice requirements for good cause shown and an effective date of November 1, 1997, for the Retail Transmission Service Agency Agreements.

GPU Energy will be serving a copy of the filing on the Pennsylvania Public Utility Commission.

Comment date: February 17, 1998, in accordance with Standard Paragraph E at the end of this notice.

11. Northern States Power Company (Minnesota Company) and Northern States Power Company (Wisconsin Company)

[Docket No. ER98-1410-000]

Take notice that on January 13, 1998, Northern States Power Company (Minnesota), and Northern States Power Company (Wisconsin), (collectively known as NSP), tendered for filing an Electric Service Agreement between NSP and Griffin Energy Marketing, L.L.C., (Customer). This Electric Service Agreement is an enabling agreement under which NSP may provide to Customer the electric services identified in NSP Operating Companies Electric Services Tariff Original Volume No. 4.

NSP requests that this Electric Service Agreement be made effective on December 15, 1997.

Comment date: February 17, 1998, in accordance with Standard Paragraph E at the end of this notice.

12. Southern Company Services, Inc.

[Docket No. ER98-1411-000]

Take notice that on January 13, 1998, Southern Company Services, Inc. (SCSI), acting on behalf of Alabama Power Company, Georgia Power Company, Gulf Power Company, Mississippi Power Company and Savannah Electric and Power Company (collectively referred to as Southern Companies) filed a service agreement under Southern Companies' Market-Based Rate Power Sales Tariff (FERC Electric Tariff, Original Volume No. 4) with Tenaska Power Services Company. SCSI states that the service agreements will enable Southern Companies to engage in short-term market-based rate sales to this customer.

Comment date: February 18, 1998, in accordance with Standard Paragraph E at the end of this notice.

13. Ohio Edison Company and Pennsylvania Power Company

[Docket No. ER98-1412-000]

Take notice that on January 13, 1998, Ohio Edison Company tendered for filing on behalf of itself and Pennsylvania Power Company, a Service Agreement with Tenaska Power Services Company under Ohio Edison's Power Sales Tariff. This filing is made pursuant to Section 205 of the Federal Power Act.

Comment date: February 18, 1998, in accordance with Standard Paragraph E at the end of this notice.

14. Northern States Power Company (Minnesota Company)

[Docket No. ER98-1413-000]

Take notice that on January 13, 1998, Northern States Power Company (Minnesota)(NSP), tendered for filing a Non-Firm Point-to-Point Transmission Service Agreement and a Short-Term Firm Transmission Service Agreement between NSP and GenSys Energy.

NSP requests that the Commission accept both the agreements effective December 19, 1997, and requests waiver of the Commission's notice requirements in order for the agreements to be accepted for filing on the date requested.

Comment date: February 18, 1998, in accordance with Standard Paragraph E at the end of this notice.

15. PP&L, Inc.

[Docket No. ER98-1414-000]

Take notice that on January 13, 1998, PP&L, Inc. (formerly known as Pennsylvania Power & Light Company)(PP&L), filed a Service Agreement dated January 9, 1998, with Electric Clearinghouse, Inc. (ECI), under PP&L's FERC Electric Tariff, Original Volume No. 5. The Service Agreement adds ECI as an eligible customer under the Tariff.

PP&L requests an effective date of January 13, 1998, for the Service Agreement.

PP&L states that copies of this filing have been supplied to ECI and to the Pennsylvania Public Utility Commission.

Comment date: February 18, 1998, in accordance with Standard Paragraph E at the end of this notice.

16. PJM Interconnection, L.L.C.

[Docket No. ER98-1415-000]

Take notice that on January 13, 1998, the PJM Interconnection, L.L.C. (PJM), filed, on behalf of the Members of the LLC Agreement, membership application of Engage Energy US, LP., and Montaup Electric Company. PJM requests an effective date on the day after this notice of filing is received by FERC.

Comment date: February 18, 1998, in accordance with Standard Paragraph E at the end of this notice.

17. Consumers Energy Company

[Docket No. ER98-1416-000]

Take notice that on January 13, 1998, Consumers Energy Company (Consumers), tendered for filing executed service agreements for Non-Firm Point-to-Point Transmission Service pursuant to the Joint Open Access Transmission Service Tariff filed on December 31, 1996, by Consumers and The Detroit Edison Company (Detroit Edison), with the following transmission customers:

1. American Electric Power Company, Inc.'s operating utility subsidiaries and The American Electric Power Service Corporation as agent for and on behalf of those subsidiaries.
2. The Cincinnati Gas & Electric Company; PSI Energy, Inc.; and Cinergy Services, Inc., as agent for and on behalf of the Cinergy Operating Companies.
3. WPS Energy Services, Inc.
4. New York State Electric & Gas Corporation
5. Engage Energy US, L.P.

Copies of the filed agreements were served upon the Michigan Public Service Commission, Detroit Edison and the respective transmission customers.

Comment date: February 18, 1998, in accordance with Standard Paragraph E at the end of this notice.

18. Western Regional Transmission Association

[Docket No. ER98-1417-000]

Take notice that on January 13, 1998, Western Regional Transmission Association, tendered for filing the Member Signature Page executed by The California ISO to become a member of the Western Regional Transmission Association.

Comment date: February 18, 1998, in accordance with Standard Paragraph E at the end of this notice.

19. Western Regional Transmission Association

[Docket No. ER98-1418-000]

Take notice that on January 13, 1998, the Western Regional Transmission Association, tendered for filing an amendment to their Governing Agreement. The amendment affects Section 12 of the Agreement concerning Dispute Resolution, and expands the available pool of facilitators from Association Members to any qualified individual.

Comment date: February 18, 1998, in accordance with Standard Paragraph E at the end of this notice.

20. Western Regional Transmission Association

[Docket No. ER98-1419-000]

Take notice that on January 13, 1998, NGC Corporation, tendered for filing a notice that it has acquired Destec Energy, Inc., as well as Electric Clearinghouse, Inc., and is withdrawing Destec Energy, Inc., from the Western Regional Transmission Association.

Comment date: February 18, 1998, in accordance with Standard Paragraph E at the end of this notice.

21. PJM Interconnection, L.L.C.

[Docket No. ER98-1420-000]

Take notice that on January 14, 1998, PJM Interconnection, L.L.C. (PJM), tendered for filing 6 executed service agreements for non-firm point-to-point transmission service under the PJM Open Access Tariff.

Copies of this filing were served upon the parties to the service agreements.

Comment date: February 18, 1998, in accordance with Standard Paragraph E at the end of this notice.

22. Polaris Electric Power Company, Inc.

[Docket No. ER98-1421-000]

Take notice that on January 14, 1998, Polaris Electric Power Company, Inc.

(Polaris), petitioned the Commission for acceptance of Polaris Rate Schedule FERC No. 1; the granting of certain blanket approvals, including the authority to sell electricity at market-based rates; and the waiver of certain Commission Regulations.

Polaris intends to engage in wholesale electric power and energy purchases and sales as a marketer. Polaris is not in the business of generating or transmitting electric power. Polaris has no affiliates.

Comment date: February 18, 1998, in accordance with Standard Paragraph E at the end of this notice.

23. South Carolina Electric & Gas Company

[Docket No. ER98-1422-000]

Take notice that on January 14, 1998, South Carolina Electric & Gas Company (SCE&G), submitted a service agreement establishing Avista Energy, Inc. (AVISTA), as a customer under the terms of SCE&G's Negotiated Market Sales Tariff.

SCE&G requests an effective date of one day subsequent to the filing of the service agreement. Accordingly, SCE&G requests waiver of the Commission's notice requirements. Copies of this filing were served upon AVISTA and the South Carolina Public Service Commission.

Comment date: February 18, 1998, in accordance with Standard Paragraph E at the end of this notice.

24. Wisconsin Public Service Corporation

[Docket No. ER98-1423-000]

Take notice that on January 14, 1998, Wisconsin Public Service Corporation (WPSC), tendered for filing Supplement No. 11 to its service agreement with Consolidated Water Power Company (CWPCO). Supplement No. 11 provides CWPCO's contract demand nominations for January 1998-December 2002, under WPSC's W-3 tariff and CWPCO's applicable service agreement.

The company states that copies of this filing have been served upon CWPCO and to the State Commissions where WPSC serves at retail.

Comment date: February 18, 1998, in accordance with Standard Paragraph E at the end of this notice.

25. New Century Services, Inc.

[Docket No. ER98-1424-000]

Take notice that on January 14, 1998, New Century Services, Inc., on behalf of Cheyenne Light, Fuel and Power Company, Public Service Company of Colorado, and Southwestern Public Service Company (collectively

Companies), tendered for filing an Umbrella Service Agreement under their Joint Open Access Transmission Service Tariff for Firm Point-to-Point Transmission Service between the Companies and Platte River Power Authority.

Comment date: February 18, 1998, in accordance with Standard Paragraph E at the end of this notice.

26. Jersey Central Power & Light Company, Metropolitan Edison Company, and Pennsylvania Electric Company

[Docket No. ER98-1425-000]

Take notice that on January 14, 1998, Jersey Central Power & Light Company, Metropolitan Edison Company and Pennsylvania Electric Company (d/b/a GPU Energy), filed an executed Service Agreement between GPU Energy and DTE Energy Trading, Inc. (DET), dated January 8, 1998. This Service Agreement specifies that DET has agreed to the rates, terms and conditions of GPU Energy's Capacity, Energy and Capacity Credit Sales Tariff (Sales Tariff) designated as FERC Electric Tariff, Second Revised Volume No. 1. The Sales Tariff allows GPU Energy and DET to enter into separately scheduled transactions under which GPU Energy will make available for sale, capacity, energy and capacity credits.

GPU Energy requests a waiver of the Commission's notice requirements for good cause shown and an effective date of January 8, 1998, for the Service Agreement.

GPU Energy has served copies of the filing on regulatory agencies in New Jersey and Pennsylvania.

Comment date: February 18, 1998, in accordance with Standard Paragraph E at the end of this notice.

27. PJM Interconnection, L.L.C.

[Docket No. ER98-1426-000]

Take notice that on January 14, 1998, the PJM Interconnection, L.L.C. (PJM), filed, on behalf of the Members of the LLC Agreement, membership application of Tractebel Energy Marketing, Inc. PJM requests an effective date on the day after this notice of filing is received by FERC.

Comment date: February 18, 1998, in accordance with Standard Paragraph E at the end of this notice.

28. New Century Services, Inc.

[Docket No. ER98-1427-000]

Take notice that on January 14, 1998, New Century Services, Inc., on behalf of Cheyenne Light, Fuel and Power Company, Public Service Company of Colorado, and Southwestern Public

Service Company (collectively Companies), tendered for filing an Umbrella Service Agreement under their Joint Open Access Transmission Service Tariff for Non-Firm Point-to-Point Transmission Service between the Companies and Wyoming Municipal Power Agency.

Comment date: February 18, 1998, in accordance with Standard Paragraph E at the end of this notice.

29. New Century Services, Inc.

[Docket No. ER98-1428-000]

Take notice that on January 14, 1998, New Century Services, Inc., on behalf of Cheyenne Light, Fuel and Power Company, Public Service Company of Colorado, and Southwestern Public Service Company (collectively Companies), tendered for filing an Umbrella Service Agreement under their Joint Open Access Transmission Service Tariff for Firm Point-to-Point Transmission Service between the Companies and WPECO-Colorado.

Comment date: February 18, 1998, in accordance with Standard Paragraph E at the end of this notice.

30. Entergy Services, Inc.

[Docket No. ER98-1429-000]

Take notice that on January 14, 1998, Entergy Services, Inc. (Entergy Services), on behalf of Entergy Arkansas, Inc., has filed the Twenty-Seventh Amendment (Amendment) to the Power Coordination, Interchange and Transmission Agreement (PCITA) between Entergy Arkansas, Inc., and Arkansas Electric Cooperative Corporation (AECC). Entergy Services states that, among other things, the Amendment adds additional delivery points between Entergy Arkansas, Inc., and AECC.

Comment date: February 18, 1998, in accordance with Standard Paragraph E at the end of this notice.

31. Entergy Services, Inc.

[Docket No. ER98-1431-000]

Take notice that on January 14, 1998, Entergy Services, Inc. (Entergy Services), on behalf of Entergy Arkansas, Inc., Entergy Gulf States, Inc., Entergy Louisiana, Inc., Entergy Mississippi, Inc., and Entergy New Orleans, Inc. (collectively, the Entergy Operating Companies), tendered for filing a Short-Term Firm Point-To-Point Transmission Service Agreement between Entergy Services, as agent for the Entergy Operating Companies, and South Mississippi Electric Power Association.

Comment date: February 18, 1998, in accordance with Standard Paragraph E at the end of this notice.

32. Boston Edison Company

[Docket No. ER98-1432-000]

Take notice that on January 14, 1998, Boston Edison Company (Boston Edison), tendered for filing a Service Agreement under Original Volume No. 8, FERC Order No. 888 Tariff (Tariff) for Cinergy Capital & Trading, Inc., (Cinergy). Boston Edison requests that the Service Agreement become effective as of January 1, 1998.

Edison states that it has served a copy of this filing on Cinergy and the Massachusetts Department of Public Utilities.

Comment date: February 18, 1998, in accordance with Standard Paragraph E at the end of this notice.

33. Northeast Utilities Service Company

[Docket No. ER98-1433-000]

Take notice that on January 13, 1998, Northeast Utilities Service Company (NUSCO), tendered for filing, a Service Agreement with US Gen Power Services, LP under the NU System Companies' Sale for Resale, Tariff No. 7.

NUSCO states that a copy of this filing has been mailed to US Gen Power Services, LP.

NUSCO requests that the Service Agreement become effective January 14, 1998.

Comment date: February 18, 1998, in accordance with Standard Paragraph E at the end of this notice.

34. Allegheny Power Service Corporation, on behalf of Monongahela Power Company, The Potomac Edison Company, and West Penn Power Company (Allegheny Power)

[Docket No. ER98-1434-000]

Take notice that on January 15, 1998, Allegheny Power Service Corporation on behalf of Monongahela Power Company, The Potomac Edison Company and West Penn Power Company (Allegheny Power), filed Supplement No. 37 to add one (1) new Customer to the Standard Generation Service Rate Schedule under which Allegheny Power offers standard generation and emergency service on an hourly, daily, weekly, monthly or yearly basis. Allegheny Power requests a waiver of notice requirements to make service available as of November 1, 1997, to Allegheny Energy Solutions, Inc.

Copies of the filing have been provided to the Public Utilities Commission of Ohio, the Pennsylvania Public Utility Commission, the Maryland Public Service Commission, the Virginia State Corporation Commission, the West Virginia Public

Service Commission, and all parties of record.

Comment date: February 18, 1998, in accordance with Standard Paragraph E at the end of this notice.

35. Washington Water Power

[Docket No. ER98-1435-000]

Take notice that on January 15, 1998, Washington Water Power, tendered for filing with the Federal Energy Regulatory Commission, pursuant to 18 CFR 35.13, an executed Service Agreement under WWP's FERC Electric Tariff First Revised Volume No. 9, with Columbia Power Marketing Corporation. WWP requests waiver of the prior notice requirement and requests an effective date of January 1, 1998.

Comment date: February 18, 1998, in accordance with Standard Paragraph E at the end of this notice.

36. Interstate Power Company

[Docket No. ER98-1439-000]

Take notice that on January 15, 1998, Interstate Power Company, tendered for filing a Notice of Cancellation of the Power Sales Agreement with Delhi Energy Services, Inc., dated April 30, 1997, pending approval under FERC Power Sales Tariff PS-1.

Comment date: February 18, 1998, in accordance with Standard Paragraph E at the end of this notice.

37. Interstate Power Company

[Docket No. ER98-1441-000]

Take notice that on January 15, 1998, Interstate Power Company, tendered for filing a Notice of Cancellation of the Service Agreement No. 35 under FERC Electric Tariff, Original Volume No. 7.

Comment date: February 18, 1998, in accordance with Standard Paragraph E at the end of this notice.

38. Louisville Gas and Electric Company

[Docket No. ER98-1442-000]

Take notice that on January 15, 1998, Louisville Gas and Electric Company (LG&E), tendered for filing an executed Purchase and Sales Agreement between LG&E and AES Power, Inc., under LG&E's Rate Schedule GSS.

Comment date: February 18, 1998, in accordance with Standard Paragraph E at the end of this notice.

39. Interstate Power Company

[Docket No. ER98-1443-000]

Take notice that on January 15, 1998, Interstate Power Company (IPW), tendered for filing a Transmission Service Agreement between IPW and Wisconsin Power and Light (WPL). Under the Transmission Service

Agreement, IPW will provide firm point-to-point transmission service to WPL.

Comment date: February 18, 1998, in accordance with Standard Paragraph E at the end of this notice.

40. Massachusetts Electric Company

[Docket No. ER98-1444-000]

Take notice that on January 14, 1998, Massachusetts Electric Company, tendered for filing rate changes to its FERC Electric Tariff, Original Volume No. 1 for borderline sales.

Comment date: February 18, 1998, in accordance with Standard Paragraph E at the end of this notice.

41. Entergy Services, Inc.

[Docket No. ER98-1445-000]

Take notice that on January 16, 1998, Entergy Services, Inc. (Entergy Services), on behalf of Entergy Arkansas, Inc., Entergy Gulf States, Inc., Entergy Louisiana, Inc., Entergy Mississippi, Inc., and Entergy New Orleans, Inc. (collectively, the Entergy Operating Companies), tendered for filing a Short-Term Firm Point-To-Point Transmission Service Agreement between Entergy Services, as agent for the Entergy Operating Companies, and OGE Energy Resources, Inc.

Comment date: February 18, 1998, in accordance with Standard Paragraph E at the end of this notice.

42. Entergy Services, Inc.

[Docket No. ER98-1446-000]

Take notice that on January 16, 1998, Entergy Services, Inc. (Entergy Services), on behalf of Entergy Arkansas, Inc., Entergy Gulf States, Inc., Entergy Louisiana, Inc., Entergy Mississippi, Inc., and Entergy New Orleans, Inc. (collectively, the Entergy Operating Companies), tendered for filing a Non-Firm Point-To-Point Transmission Service Agreement between Entergy Services, as agent for the Entergy Operating Companies, and OGE Energy Resources, Inc.

Comment date: February 18, 1998, in accordance with Standard Paragraph E at the end of this notice.

43. Entergy Services, Inc.

[Docket No. ER98-1447-000]

Take notice that on January 16, 1998, Entergy Services, Inc. (Entergy Services), on behalf of Entergy Arkansas, Inc., Entergy Gulf States, Inc., Entergy Louisiana, Inc., Entergy Mississippi, Inc., and Entergy New Orleans, Inc. (collectively, the Entergy Operating Companies), tendered for filing a Power Purchase Agreement between Entergy Services, as agent for

the Entergy Operating Companies, and Southern Company Services, Inc. (SCS), as agent for Alabama Power Company, Gulf Power Company, Mississippi Power Company and Savannah Electric and Power Company for the sale of power under Entergy Services' Rate Schedule SP.

Comment date: February 18, 1998, in accordance with Standard Paragraph E at the end of this notice.

44. Entergy Services, Inc.

[Docket No. ER98-1448-000]

Take notice that on January 16, 1998, Entergy Services, Inc. (Entergy Services), on behalf of Entergy Arkansas, Inc., Entergy Gulf States, Inc., Entergy Louisiana, Inc., Entergy Mississippi, Inc., and Entergy New Orleans, Inc. (collectively, the Entergy Operating Companies), tendered for filing a Short-Term Firm Point-To-Point Transmission Service Agreement between Entergy Services, as agent for the Entergy Operating Companies, and American Electric Power Service Corporation.

Comment date: February 18, 1998, in accordance with Standard Paragraph E at the end of this notice.

45. Entergy Services, Inc.

[Docket No. ER98-1449-000]

Take notice that on January 16, 1998, Entergy Services, Inc. (Entergy Services), on behalf of Entergy Arkansas, Inc., Entergy Gulf States, Inc., Entergy Louisiana, Inc., Entergy Mississippi, Inc., and Entergy New Orleans, Inc. (collectively, the Entergy Operating Companies), tendered for filing a Non-Firm Point-To-Point Transmission Service Agreement between Entergy Services, as agent for the Entergy Operating Companies, and American Electric Power Service Corporation.

Comment date: February 18, 1998, in accordance with Standard Paragraph E at the end of this notice.

46. Cinergy Services, Inc.

[Docket No. ER98-1450-000]

Take notice that on January 16, 1998, Cinergy Services, Inc. (Cinergy), tendered for filing a service agreement under Cinergy's Power Sales Standard Tariff (the Tariff) entered into between Cinergy and American Electric Power Service Corporation (AEP).

Cinergy and AEP are requesting an effective date of December 22, 1997.

Comment date: February 18, 1998, in accordance with Standard Paragraph E at the end of this notice.

47. Cinergy Services, Inc.

[Docket No. ER98-1451-000]

Take notice that on January 16, 1998, Cinergy Services, Inc. (Cinergy), tendered for filing a service agreement under Cinergy's Open Access transmission Service Tariff (the Tariff) entered into between Cinergy and Columbia Power Marketing, Corp., (CPM).

Cinergy and CPM are requesting an effective date of January 1, 1998.

Comment date: February 18, 1998, in accordance with Standard Paragraph E at the end of this notice.

48. Cinergy Services, Inc.

[Docket No. ER98-1452-000]

Take notice that on January 16, 1998, Cinergy Services, Inc. (Cinergy), tendered for filing a service agreement under Cinergy's Open Access Transmission Service Tariff (the Tariff) entered into between Cinergy and Columbia Power Marketing, Corp., (CPM).

Cinergy and CPM are requesting an effective date of January 1, 1998.

Comment date: February 18, 1998, in accordance with Standard Paragraph E at the end of this notice.

49. PJM Interconnection, L.L.C.

[Docket No. ER98-1453-000]

Take notice that on January 16, 1998, PJM Interconnection, L.L.C. (PJM), tendered for filing amendments to the Specifications for Network Integration Transmission Service attached to the network service agreements with Metropolitan Edison Company, Pennsylvania Electric Company, PECO Energy Company, and PP&L, Inc., filed in connection with the Pennsylvania Retail Electric Competition Pilot Program.

PJM requests a waiver of the advance notice requirements of the Commission's Regulations to permit an effective date of November 1, 1997, for the amendments.

Comment date: February 18, 1998, in accordance with Standard Paragraph E at the end of this notice.

50. MidAmerican Energy Company

[Docket No. ER98-1454-000]

Take notice that on January 16, 1998, MidAmerican Energy Company (MidAmerican), 666 Grand Avenue, Des Moines, Iowa 50309, submitted for filing Firm Transmission Service Agreement with Wisconsin Power and Light Company (WPL), dated December 22, 1997, and entered into pursuant to MidAmerican's Open Access Transmission Tariff.

MidAmerican requests an effective date of January 1, 1998, for the

Agreement and accordingly, seeks a waiver of the Commission's notice requirements. MidAmerican has served a copy of the filing on WPL, the Iowa Utilities Board, the Illinois Commerce Commission and the South Dakota Public Utilities Commission.

Comment date: February 18, 1998, in accordance with Standard Paragraph E at the end of this notice.

51. MidAmerican Energy Company

[Docket No. ER98-1455-000]

Take notice that on January 16, 1998, MidAmerican Energy Company (MidAmerican), 666 Grand Avenue, Des Moines, Iowa 50309, filed with the Commission two Non-Firm Transmission Service Agreements with Tenaska Power Services Co. (Tenaska), dated January 7, 1998, and Continental Energy Services, L.L.C. (Continental), dated January 12, 1998, entered into pursuant to MidAmerican's Open Access Transmission Tariff.

MidAmerican requests an effective date of January 7, 1998, for the Agreement with Tenaska and January 12, 1998, for the Agreement with Continental and seeks a waiver of the Commission's notice requirements. MidAmerican has served a copy of the filing on Tenaska, Continental, the Iowa Utilities Board, the Illinois Commerce Commission and the South Dakota Public Utilities Commission.

Comment date: February 18, 1998, in accordance with Standard Paragraph E at the end of this notice.

52. Union Electric Company

[Docket No. ER98-1457-000]

Take notice that on January 16, 1998, Union Electric Company (UE), tendered for filing a Service Agreement for Firm Point-to-Point Transmission Service between UE and OGE Energy Resources, Inc., (OGE). UE asserts that the purpose of the Agreement is to permit UE to provide transmission service to OGE pursuant to UE's Open Access Transmission Tariff filed in Docket No. OA96-50.

Comment date: February 18, 1998, in accordance with Standard Paragraph E at the end of this notice.

53. Union Electric Company

[Docket No. ER98-1458-000]

Take notice that on January 16, 1998, Union Electric Company (UE), tendered for filing a Service Agreement for Non-Firm Point-to-Point Transmission Service between UE and OGE Energy Resources, Inc., (OGE). UE asserts that the purpose of the Agreement is to permit UE to provide transmission service to OGE pursuant to UE's Open

Access Transmission Tariff filed in Docket No. OA96-50.

Comment date: February 18, 1998, in accordance with Standard Paragraph E at the end of this notice.

54. Union Electric Company

[Docket No. ER98-1459-000]

Take notice that on January 16, 1998, Union Electric Company (UE), tendered for filing a Service Agreement for Market Based Rate Power Sales between UE and American Electric Power Service Corporation (AEPS). UE asserts that the purpose of the Agreement is to permit UE to make sales of capacity and energy at market based rates to AEPS pursuant to UE's Market Based Rate Power Sales Tariff filed in Docket No. ER97-3664-000.

Comment date: February 18, 1998, in accordance with Standard Paragraph E at the end of this notice.

55. Arizona Public Service Company

[Docket No. ER98-1460-000]

Take notice that on January 16, 1998, Arizona Public Service Company (APS), tendered for filing an Umbrella Service Agreement to provide Non-Firm Point-to-Point Transmission Service under APS' Open Access Transmission Tariff with SCANA Energy Marketing, Inc.

A copy of this filing has been served on SCANA Energy Marketing, Inc., and the Arizona Corporation Commission.

Comment date: February 18, 1998, in accordance with Standard Paragraph E at the end of this notice.

56. PacifiCorp

[Docket No. ER98-1461-000]

Take notice that on January 20, 1998, PacifiCorp tendered for filing in accordance with 18 CFR Part 35 of the Commission's Regulations, a Long-Term Power Purchase Agreement (Purchase Agreement) between PacifiCorp and the City of Redding (Redding).

Copies of this filing were supplied to Redding, the Washington Utilities and Transportation Commission and the Public Utility Commission of Oregon.

Comment date: February 18, 1998, in accordance with Standard Paragraph E at the end of this notice.

57. Western Resources, Inc.

[Docket No. ER98-1462-000]

Take notice that on January 20, 1998, Western Resources, Inc., tendered for filing two non-firm transmission agreements between Western Resources and NESI Power Marketing, Inc., and Western Resources and OGE Energy Resources, Inc. Western Resources states that the purpose of the agreements is to permit non-discriminatory access to the

transmission facilities owned or controlled by Western Resources in accordance with Western Resources' open access transmission tariff on file with the Commission. The agreements are proposed to become effective January 6, 1998.

Copies of the filing were served upon NESI Power Marketing, Inc., OGE Energy Resources, Inc., and the Kansas Corporation Commission.

Comment date: February 18, 1998, in accordance with Standard Paragraph E at the end of this notice.

58. Illinois Power Company

[Docket No. ER98-1463-000]

Take notice that on January 20, 1998, Illinois Power Company (Illinois Power), 500 South 27th Street, Decatur, Illinois 62526, tendered for filing a Power Sales Tariff, Service Agreement under which Florida Power & Light Company will take service under Illinois Power Company's Power Sales Tariff. The agreements are based on the Form of Service Agreement in Illinois Power's tariff.

Illinois Power has requested an effective date of December 8, 1997.

Comment date: February 18, 1998, in accordance with Standard Paragraph E at the end of this notice.

59. South Carolina Electric & Gas Company

[Docket No. ER98-1464-000]

Take notice that on January 20, 1998, South Carolina Electric & Gas Company (SCE&G), submitted a service agreement establishing Tennessee Valley Authority (TVA), as a customer under the terms of SCE&G's Open Access Transmission Tariff.

SCE&G requests an effective date of one day subsequent to the filing of the service agreement. Accordingly, SCE&G requests waiver of the Commission's notice requirements. Copies of this filing were served upon TVA and the South Carolina Public Service Commission.

Comment date: February 18, 1998, in accordance with Standard Paragraph E at the end of this notice.

60. Boston Edison Company

[Docket No. ER98-1465-000]

Take notice that on January 20, 1998, Boston Edison Company (Boston Edison) filed a Settlement Agreement to resolve billing disputes with Commonwealth Electric Company (Commonwealth) regarding purchases from Boston Edison's Pilgrim Nuclear Power Station. The Settlement Agreement resolves disputes over 1995 and 1996 calendar year billings under

the formula rate in the contract, Boston Edison's Rate Schedule FERC No. 68.

The Settlement further provides for an amendment of Rate Schedule No. 68. Boston Edison requests that the amendment become effective upon Commission approval of the Settlement Agreement without modification. Boston Edison requests that the Commission approve the settlement on or before March 22, 1998, if possible. Boston Edison requests waiver of the Commission's prior notice requirements if Commission approval occurs before 60 days after this filing or more than 120 days after this filing.

Comment date: February 18, 1998, in accordance with Standard Paragraph E at the end of this notice.

61. Allegheny Power Service Corp. on behalf of Monongahela Power Company, The Potomac Edison Company, and West Penn Power Company (Allegheny Power)

[Docket No. ER98-1466-000]

Take notice that on January 15, 1998, Allegheny Power Service Corporation on behalf of Monongahela Power Company, The Potomac Edison Company and West Penn Power Company (Allegheny Power), refiled a market rate tariff of general applicability under which it proposes to sell capacity and energy at market-based rates. This filing is intended to comply with the Commission's directives in an order issued on December 10, 1997, in Docket No. ER98-336-000. Allegheny Power also seeks to amend its Standard Generation Service Rate Schedule to permit sales to affiliates at cost-based rates subject to limitation established by the Commission in previous orders.

Copies of the filing have been provided to the Public Utilities Commission of Ohio, the Pennsylvania Public Utility Commission, the Maryland Public Service Commission, the Virginia State Corporation Commission, the West Virginia Public Service Commission, and all parties of record.

Comment date: February 18, 1998, in accordance with Standard Paragraph E at the end of this notice.

62. Rochester Gas and Electric Corporation

[Docket No. ER98-1467-000]

Take notice that on January 20, 1998, Rochester Gas and Electric Corporation (RG&E), filed a Service Agreement between RG&E and the Energetix (Customer). This Service Agreement specifies that the Customer has agreed to the rates, terms and conditions of the RG&E open access transmission tariff

filed on July 9, 1996 in Docket No. OA96-141-000.

RG&E requests waiver of the Commission's sixty (60) day notice requirements and an effective date of January 12, 1998, for the Energetix Service Agreement. RG&E has served copies of the filing on the New York State Public Service Commission and on the Customer.

Comment date: February 18, 1998, in accordance with Standard Paragraph E at the end of this notice.

63. Southwestern Public Service Company

[Docket No. ER98-1468-000]

Take notice that on January 20, 1998, Southwestern Public Service Company tendered for filing a Notice of Cancellation of Service Schedule E to the Interconnection Agreement between Southwestern and El Paso Electric Company.

Comment date: February 18, 1998, in accordance with Standard Paragraph E at the end of this notice.

64. Louisville Gas and Electric Company

[Docket No. ER98-1469-000]

Take notice that on January 20, 1998, Louisville Gas and Electric Company (LG&E), tendered for filing an executed Non-Firm Point-To-Point Transmission Service Agreement between LG&E and City Water, Light and Power, Springfield, Illinois under LG&E's Open Access Transmission Tariff.

Comment date: February 18, 1998, in accordance with Standard Paragraph E at the end of this notice.

65. Illinois Power Company

[Docket No. ER98-1470-000]

Take notice that on January 20, 1998, Illinois Power Company (Illinois Power), 500 South 27th Street, Decatur, Illinois 62526, tendered for filing a Power Sales Tariff, Service Agreement under which Tenaska Power Services Co., will take service under Illinois Power Company's Power Sales Tariff. The agreements are based on the Form of Service Agreement in Illinois Power's tariff.

Illinois Power has requested an effective date of January 14, 1998.

Comment date: February 18, 1998, in accordance with Standard Paragraph E at the end of this notice.

66. Illinois Power Company

[Docket No. ER98-1471-000]

Take notice that on January 20, 1998, Illinois Power Company (Illinois Power), 500 South 27th Street, Decatur, Illinois 62526, tendered for filing a

Power Sales Tariff, Service Agreement under which Plum Street Energy Marketing will take service under Illinois Power Company's Power Sales Tariff. The agreements are based on the Form of Service Agreement in Illinois Power's tariff.

Illinois Power has requested an effective date of January 1, 1998.

Comment date: February 19, 1998, in accordance with Standard Paragraph E at the end of this notice.

67. UtiliCorp United Inc.

[Docket No. ER98-1472-000]

Take notice that on January 20, 1998, UtiliCorp United Inc. (UtiliCorp), filed service agreements with Columbia Power Marketing Corporation for service under its Short-Term Firm Point-to-Point open access service tariff for its operating divisions, Missouri Public Service, WestPlains Energy-Kansas and WestPlains Energy-Colorado.

Comment date: February 19, 1998, in accordance with Standard Paragraph E at the end of this notice.

68. PJM Interconnection, L.L.C.

[Docket No. ER98-1638-000]

Take notice that on January 30, 1998, PJM Interconnection, L.L.C. (PJM), tendered for filing a proposed Schedule 10—Accounting for Unscheduled Transmission Service Compensation—to the Amended and Restated Operating Agreement of PJM Interconnection, L.L.C., (PJM Operating Agreement).

PJM requests a waiver of the Commission's Regulations to allow an effective date of January 1, 1998, for Schedule 10. PJM also requests that Schedule 10 terminate on March 31, 1998.

Comment date: February 19, 1998, in accordance with Standard Paragraph E at the end of this notice.

69. Pennsylvania-New Jersey-Maryland Interconnection

[Docket No. ER98-1649-000]

Take notice that on January 30, 1998, PJM Interconnection, L.L.C. (PJM), tendered for filing amendments to the Operating agreement of the PJM Interconnection, L.L.C., and the PJM Open access Transmission Tariff.

The amendments (1) enable PJM to obtain energy from members in emergencies, (2) enable PJM to pay members their actual costs incurred when PJM directs the cancellation of start-up of a generating unit, (3) change the date and time by which certain requests for non-firm transmission service must be made, and (4) correct the congestion pricing provisions so that PJM credits non-firm transmission

customers that buy-through congestion, when their transactions produce flows that alleviate congestion.

PJM requests an effective date of April 1, 1998, for the amendments to the Operating Agreement and PJM Tariff.

Comment date: February 19, 1998, in accordance with Standard Paragraph E at the end of this notice.

Standard Paragraph

E. Any person desiring to be heard or to protest said filing should file a motion to intervene or protest with the Federal Energy Regulatory Commission, 888 First Street, N.E., Washington, D.C. 20426, in accordance with Rules 211 and 214 of the Commission's Rules of Practice and Procedure (18 CFR 385.211 and 18 CFR 385.214). All such motions or protests should be filed on or before the comment date. Protests will be considered by the Commission in determining the appropriate action to be taken, but will not serve to make protestants parties to the proceeding. Any person wishing to become a party must file a motion to intervene. Copies of these filings are on file with the Commission and are available for public inspection.

David P. Boergers,

Acting Secretary.

[FR Doc. 98-3291 Filed 2-9-98; 8:45 am]

BILLING CODE 6717-01-P

DEPARTMENT OF ENERGY

Federal Energy Regulatory Commission

[Docket No. DR98-45-000, et al.]

Pacific Gas and Electric Company, et al.; Electric Rate and Corporate Regulation Filings

February 3, 1998.

Take notice that the following filings have been made with the Commission:

1. Pacific Gas and Electric Company

[Docket No. DR98-45-000]

Take notice that on January 7, 1998, Pacific Gas and Electric Company (PG&E), filed an Application for approval of depreciation rates for accounting purposes only pursuant to Section 302 of the Federal Power Act and Rule 204 of the Commission's Rules of Practice and Procedure. PG&E stated that the proposed rates were approved by the California Public Utilities Commission and became effective for retail purposes as of January 1, 1994, 1995, 1996 and 1997. PG&E requests that the Commission allow the proposed depreciation rates to become effective

on January 1, 1994, 1995, 1996 and 1997.

Comment date: March 4, 1998, in accordance with Standard Paragraph E at the end of this notice.

2. Oeste Power Generation, L.L.C.

[Docket No. EG98-24-000]

Take notice that on January 26, 1998, Oeste Power Generation, L.L.C. (Oeste Power), with its principal office at c/o Houston Industries Power Generation, Inc., 1111 Louisiana, 16th Floor, Houston TX 77002, filed with the Federal Energy Regulatory Commission (Commission) an amendment to its application for determination of exempt wholesale generator status pursuant to Part 365 of the Commission's Regulations. Oeste Power is a wholly owned subsidiary of Houston Industries Power Generation, Inc., and an indirect subsidiary of Houston Industries Incorporated. Oeste Power has acquired the Ellwood Energy Support Facility in Goleta, California at auction from Southern California Edison. Oeste Power states that it will be engaged directly, or indirectly through one or more affiliates, as defined in Section 2(a)(11)(B) of PUHCA, and exclusively in the business of owning and or operating, an interest in an eligible facility and selling electric energy at wholesale.

Comment date: February 18, 1998, in accordance with Standard Paragraph E at the end of this notice. The Commission will limit its consideration of comments to those that concern the adequacy or accuracy of the amended application.

3. Mountain Vista Power Generation, L.L.C.

[Docket No. EG98-25-000]

Take notice that on January 26, 1998, Mountain Vista Power Generation, L.L.C. (Mountain Vista), with its principal office at c/o Houston Industries Power Generation, Inc., 1111 Louisiana, 16th Floor, Houston, TX 77002, filed with the Federal Energy Regulatory Commission (Commission), an amendment to its application for determination of exempt wholesale generator status pursuant to Part 365 of the Commission's Regulations. Mountain Vista is a wholly owned subsidiary of Houston Industries Power Generation, Inc., and an indirect subsidiary of Houston Industries Incorporated. Mountain Vista has acquired the Etiwanda Generating Station in Rancho Cucamonga, California at auction from Southern California Edison. Mountain Vista states that it will be engaged directly, or

indirectly through one or more affiliates, as defined in Section 2(a)(11)(B) of PUHCA, and exclusively in the business of owning and or operating, an interest in an eligible facility and selling electric energy at wholesale.

Comment date: February 18, 1998, in accordance with Standard Paragraph E at the end of this notice. The Commission will limit its consideration of comments to those that concern the adequacy or accuracy of the amended application.

4. New Century Services, Inc.

[Docket No. ER98-1377-000]

Take notice that on January 9, 1998, New Century Services, Inc., on behalf of Cheyenne Light, Fuel and Power Company, Public Service Company of Colorado (collectively Companies), tendered for filing a Service Agreement under their Joint Open Access Transmission Tariff for Firm Point-to-Point Transmission Service between the Companies and Southwestern Public Service Company—Wholesale Merchant Function.

Comment date: February 17, 1998, in accordance with Standard Paragraph E at the end of this notice.

5. Northeast Utilities Service Company

[Docket No. ER98-1378-000]

Take notice that on January 9, 1998, Northeast Utilities Service Company (NUSCO), tendered for filing, a Service Agreement to provide Network Integration Transmission Service to Western Massachusetts Electric Company (WMECO) under the NU System Companies' Open Access Transmission Service Tariff No. 9. NUSCO states that the transmission service provided under the Service Agreement would support WMECO's proposal for standard offer service which is required to be in place by March 1, 1998, pursuant to the Massachusetts electric industry restructuring legislation.

NUSCO requests that the Service Agreement become effective on March 1, 1998 to coincide with the legislated start date for customer choice in Massachusetts.

Comment date: February 17, 1998, in accordance with Standard Paragraph E at the end of this notice.

6. Southwestern Public Service Company

[Docket No. ER98-1379-000]

Take notice that on January 9, 1998, Southwestern Public Service Company (Southwestern), submitted an agreement with UtiliCorp United, Inc. (UtiliCorp), for service to WestPlains Energy—Colorado Division (WPECO).

Comment date: February 17, 1998, in accordance with Standard Paragraph E at the end of this notice.

7. Southern Indiana Gas and Electric Company

[Docket No. ER98-1380-000]

Take notice that on January 9, 1998, Southern Indiana Gas and Electric Company (SIGECO), tendered for filing one (1) service agreement for non-firm transmission service under Part II of its Transmission Services Tariff with Tenaska Power Services Company.

Copies of the filing were served upon each of the parties to the service agreement.

Comment date: February 17, 1998, in accordance with Standard Paragraph E at the end of this notice.

8. Southern Indiana Gas and Electric Company

[Docket No. ER98-1381-000]

Take notice that on January 9, 1998, Southern Indiana Gas and Electric Company (SIGECO), tendered for filing one (1) service agreement for firm transmission service under Part II of its Transmission Services Tariff with Tenaska Power Services Company.

Copies of the filing were served upon each of the parties to the service agreement.

Comment date: February 17, 1998, in accordance with Standard Paragraph E at the end of this notice.

9. Southern Indiana Gas and Electric Company

[Docket No. ER98-1382-000]

Take notice that on January 9, 1998, Southern Indiana Gas and Electric Company (SIGECO), tendered for filing one (1) service agreement for market based rate power sales under its Market Based Rate Tariff with Tenaska Power Services Company.

Copies of the filing were served upon each of the parties to the service agreement.

Comment date: February 17, 1998, in accordance with Standard Paragraph E at the end of this notice.

10. Southwestern Public Service Company

[Docket No. ER98-1383-000]

Take notice that on January 9, 1998, Southwestern Public Service Company, submitted an agreement with El Paso Electric Company.

Comment date: February 17, 1998, in accordance with Standard Paragraph E at the end of this notice.

11. PJM Interconnection, L.L.C.

[Docket No. ER98-1384-000]

Take notice that on January 9, 1998, PJM Interconnection, L.L.C., pursuant to 29.1 and 29.5 of the PJM Open Access Transmission Tariff, filed an unexecuted Service Agreement for Network Integration Transmission Service with The Cleveland Electric Illuminating Company and a related Agency Agreement to allow transmission over specified lower voltage facilities with Pennsylvania Electric Company.

PJM requests a waiver of the Commission's Regulations to allow an effective date of January 1, 1998, for the agreements.

Copies of the filing were served upon The Cleveland Electric Illuminating Company, Pennsylvania Electric Company, Wellsboro Electric Company, and the Pennsylvania Public Utility Commission.

Comment date: February 17, 1998, in accordance with Standard Paragraph E at the end of this notice.

12. Central Illinois Public Service Company

[Docket No. ER98-1385-000]

Take notice that on January 9, 1998, Central Illinois Public Service Company (CIPS), submitted an executed umbrella short-term firm transmission service agreement, dated December 31, 1997, establishing City Water, Power and Light (Springfield, Illinois) as a customer under the terms of CIPS' Open Access Transmission Tariff.

CIPS requests an effective date of December 31, 1997, for the service agreement with City Water, Power and Light. Accordingly, CIPS requests waiver of the Commission's notice requirements. Copies of this filing were served on City Water, Power and Light and the Illinois Commerce Commission.

Comment date: February 17, 1998, in accordance with Standard Paragraph E at the end of this notice.

13. PJM Interconnection, L.L.C.

[Docket No. ER98-1386-000]

Take notice that on January 9, 1998, the PJM Interconnection, L.L.C. (PJM), tendered for filing notice of the withdrawal from PJM of MidCon Gas Services Corporation and Mc2, Inc., on December 31, 1997.

Comment date: February 17, 1998, in accordance with Standard Paragraph E at the end of this notice.

14. Sempra Energy Trading Corp.

[Docket No. ER98-1387-000]

Take notice that on January 9, 1998, AIG Trading Corporation, a broker and marketer of electric power, has changed

its name to Sempra Energy Trading Corp. Accordingly, pursuant to 18 CFR 35.16 and 18 CFR 131.51, Sempra Energy Trading Corp., One Greenwich Plaza, Greenwich, Connecticut 06830, adopts, ratifies, and makes its own in every respect all applicable rate schedules, and supplements thereto, listed below, heretofore filed with the Federal Energy Regulatory Commission by AIG Trading Corporation, effective December 31, 1997.

- (1) Rate Schedule FERC No. 1
- (2) Code of Conduct

Comment date: February 17, 1998, in accordance with Standard Paragraph E at the end of this notice.

15. Indiana Michigan Power Company

[Docket No. ER98-1388-000]

Take notice that on January 12, 1998, Indiana Michigan Power Company (I&M), tendered for filing with the Commission an executed Electric Service Agreement (ESA), with South Haven, Michigan (South Haven), under I&M's Tariff MRS, designated as I&M FERC Electric Tariff Original Volume No. 7, and a letter agreement that supplements the proposed ESA. I&M requests waiver of notice to permit the ESA, as supplemented, to be made effective for service billed on and after November 24, 1997.

I&M states that a copy of its filing was served upon South Haven and the Michigan Public Service Commission.

Comment date: February 17, 1998, in accordance with Standard Paragraph E at the end of this notice.

16. Boston Edison Company

[Docket No. ER98-1389-000]

Take notice that on January 12, 1998, Boston Edison Company filed a Settlement Agreement to resolve billing disputes with thirteen municipal electric system purchasers of power from its Pilgrim Nuclear Power Station. The Settlement Agreement also provides for amendments of three sections of the Pilgrim contracts with each of the municipal purchasers.

The applicable Rate Schedules are as follows:

- (1) Rate Schedule No. 77
Boylston Municipal Light Department
- (2) Rate Schedule No. 79
Holyoke Gas and Electric Department
- (3) Rate Schedule No. 81
Westfield Gas and Electric Light Department
- (4) Rate Schedule No. 83
Hudson Light and Power Department
- (5) Rate Schedule No. 85
Littleton Electric Light and Water Department
- (6) Rate Schedule No. 87

Marblehead Municipal Light Department

- (7) Rate Schedule No. 89
North Attleborough Electric Department
- (8) Rate Schedule No. 91
Peabody Municipal Light Plant
- (9) Rate Schedule No. 93
Shrewsbury's Electric Light Plant
- (10) Rate Schedule No. 95
Templeton Municipal Light Plant
- (11) Rate Schedule No. 97
Wakefield Municipal Light Department
- (12) Rate Schedule No. 99
West Boylston Municipal Lighting Plant
- (13) Rate Schedule No. 102
Middleborough Gas and Electric Department

Boston Edison requests that the contract amendments take effect upon Commission approval of the settlement without modification. Boston Edison requests that the Commission act if possible on the settlement on or before March 16, 1998. If such approval is issued prior to 60 days or more than 120 days after the filing, Boston Edison requests waiver of the prior notice requirement.

Comment date: February 17, 1998, in accordance with Standard Paragraph E at the end of this notice.

17. Public Service Company of New Mexico

[Docket No. ER98-1390-000]

Take notice that on January 12, 1998, Public Service Company of New Mexico (PNM), submitted for filing executed service agreements for point-to-point transmission service under the terms of PNM's Open Access Transmission Service Tariff with the following transmission service customers: British Columbia Power Exchange (2 agreements, dated December 31, 1997, for Non-Firm and Firm Service), Entergy Power Marketing Corporation (2 agreements, dated December 18, 1997, for Non-Firm and Firm Service), Power Fuels, Incorporated (2 agreements, dated December 16, 1997, for Non-Firm and Firm Service), Cook Inlet Energy Supply, LP, (dated September 25, 1997, for Firm Service). PNM's filing is available for public inspection at its offices in Albuquerque, New Mexico.

Comment date: February 17, 1998, in accordance with Standard Paragraph E at the end of this notice.

18. UtiliCorp United Inc.

[Docket No. ER98-1391-000]

Take notice that on January 12, 1998, UtiliCorp United Inc., (UtiliCorp) tendered for filing on behalf of its

operating division, Missouri Public Service, a Service Agreement under its Power Sales Tariff, FERC Electric Tariff Original Volume No. 10, with Cargill-IEC, LLC. The Service Agreement provides for the sale of capacity and energy by Missouri Public Service to Cargill-IEC, LLC pursuant to the tariff, and for the sale of capacity and energy by Cargill-IEC, LLC to Missouri Public Service pursuant to Cargill-IEC, LLC's Rate Schedule No. 1.

UtiliCorp also has tendered for filing a Certificate of Concurrence by Cargill-IEC, LLC.

UtiliCorp requests waiver of the Commission's regulations to permit the Service Agreement to become effective in accordance with its terms.

Comment date: February 17, 1998, in accordance with Standard Paragraph E at the end of this notice.

19. UtiliCorp United Inc.

[Docket No. ER98-1392-000]

Take notice that on January 12, 1998, UtiliCorp United Inc., (UtiliCorp) tendered for filing on behalf of its operating division, WestPlains Energy-Kansas, a Service Agreement under its Power Sales Tariff, FERC Electric Tariff Original Volume No. 12, with Cargill-IEC, LLC. The Service Agreement provides for the sale of capacity and energy by WestPlains Energy-Kansas to Cargill-IEC, LLC pursuant to the tariff, and for the sale of capacity and energy by Cargill-IEC, LLC to WestPlains Energy-Kansas pursuant to Cargill-IEC, LLC's Rate Schedule No. 1.

UtiliCorp also has tendered for filing a Certificate of Concurrence by Cargill-IEC, LLC.

UtiliCorp requests waiver of the Commission's regulations to permit the Service Agreement to become effective in accordance with its terms.

Comment date: February 17, 1998, in accordance with Standard Paragraph E at the end of this notice.

20. UtiliCorp United Inc.

[Docket No. ER98-1393-000]

Take notice that on January 12, 1998, UtiliCorp United Inc., (UtiliCorp) tendered for filing on behalf of its operating division, WestPlains Energy-Colorado, a Service Agreement under its Power Sales Tariff, FERC Electric Tariff Original Volume No. 11, with Cargill-IEC, LLC. The Service Agreement provides for the sale of capacity and energy by WestPlains Energy-Colorado to Cargill-IEC, LLC pursuant to the tariff, and for the sale of capacity and energy by Cargill-IEC, LLC to WestPlains Energy-Colorado pursuant to Cargill-IEC, LLC's Rate Schedule No. 1.

UtiliCorp also has tendered for filing a Certificate of Concurrence by Cargill-IEC, LLC.

UtiliCorp requests waiver of the Commission's regulations to permit the Service Agreement to become effective in accordance with its terms.

Comment date: February 17, 1998, in accordance with Standard Paragraph E at the end of this notice.

21. Ohio Edison Company

[Docket No. ER98-1396-000]

Take notice that on January 12, 1998, Ohio Edison Company tendered for filing revisions to Appendices A and B of Service Agreements with American Municipal Power-Ohio, Inc., under FERC Electric Tariff, Second Revised Volume No. 2. This filing is made pursuant to Section 205 of the Federal Power Act.

Comment date: February 17, 1998, in accordance with Standard Paragraph E at the end of this notice.

22. Kansas City Power & Light Company

[Docket No. ER98-1397-000]

Take notice that on January 12, 1998, Kansas City Power & Light Company (KCPL) tendered for filing a Service Agreement dated January 7, 1998, between KCPL and American Electric Power Corp. KCPL proposes an effective date of January 7, 1998, and requests waiver of the Commission's notice requirement. This Agreement provides for Non-Firm Power Sales Service.

In its filing, KCPL states that the rates included in the above-mentioned Service Agreement are pursuant to KCPL's compliance filing in Docket No. ER94-1045.

Comment date: February 17, 1998, in accordance with Standard Paragraph E at the end of this notice.

23. PacifiCorp

[Docket No. ER98-1398-000]

Take notice that on January 12, 1998, PacifiCorp, tendered for filing in accordance with 18 CFR 35 of the Commission's Rules and Regulations, a Service Agreement with Edison Source under PacifiCorp's FERC Electric Tariff, First Revised Volume No. 12.

Copies of this filing were supplied to the Public Utility Commission of Oregon and the Washington Utilities and Transportation Commission.

Comment date: February 17, 1998, in accordance with Standard Paragraph E at the end of this notice.

24. Cinergy Capital & Trading, Inc.

[Docket No. ER98-1399-000]

Take notice that on January 12, 1998, Cinergy Capital & Trading, Inc. filed

with the Commission a notice of acceptance of their status as signatory parties to the Western System Power Pool Agreement.

Cinergy Capital & Trading, Inc. requests that its membership be made effective as of February 1, 1998.

Copies of the filing were served upon representatives of the Western Systems Power Pool.

Comment date: February 17, 1998, in accordance with Standard Paragraph E at the end of this notice.

25. Cinergy Services, Inc., The Cincinnati Gas & Electric Co. and PSI Energy, Inc.

[Docket No. ER98-1401-000]

Take notice that on January 12, 1998, Cinergy Services, Inc., on behalf of The Cincinnati Gas & Electric Company and PSI Energy, Inc., filed an amendment to its Power Sales Agreement with The Commissioners of Public Works of the City of Greenwood, South Carolina in order to make a ministerial correction to the Agreement. Cinergy requests an effective date of January 12, 1998 for its amendment.

Cinergy Services, Inc. has served this filing upon The Commissioners of Public Works of the City of Greenwood, South Carolina, The South Carolina Public Service Commission and Duke Power Company.

Comment date: February 17, 1998, in accordance with Standard Paragraph E at the end of this notice.

26. Commonwealth Edison Company

[Docket No. ER98-1402-000]

Take notice that on January 12, 1998, Commonwealth Edison Company (ComEd) submitted for filing a Service Agreement establishing Tenaska Power Services Co. (TPS) as a customer under the terms of ComEd's Power Sales and Reassignment of Transmission Rights Tariff PSRT-1 (PSRT-1 Tariff). The Commission has previously designated the PSRT-1 Tariff as FERC Electric Tariff, First Revised Volume No. 2.

ComEd requests an effective date of December 5, 1997, and accordingly seeks waiver of the Commission's notice requirements. Copies of this filing were served upon TPS and the Illinois Commerce Commission.

Comment date: February 17, 1998, in accordance with Standard Paragraph E at the end of this notice.

27. Florida Power Corporation

[Docket No. ER98-1403-000]

Take notice that on January 12, 1998, Florida Power Corporation (FPC) tendered for filing a service agreement between Western Resources, Inc. and

FPC for service under FPC's Market-Based Wholesale Power Sales Tariff (MR-1), FERC Electric Tariff, Original Volume Number 8. This tariff was accepted for filing by the Commission on June 26, 1997, in Docket No. ER97-2846-000. The service agreement is proposed to be effective December 16, 1997.

Comment date: February 17, 1998, in accordance with Standard Paragraph E at the end of this notice.

28. Enron Energy Services Power, Inc.
[Docket No. ER98-1404-000]

Take notice that on January 12, 1998, Enron Energy Services Power, Inc. tendered for filing notification of a change of name in the above-captioned docket. Enron Energy Services Power, Inc. changed its name to Enron Energy Services, Inc. on December 19, 1997.

Comment date: February 17, 1998, in accordance with Standard Paragraph E at the end of this notice.

29. Pacific Gas & Electric Company, San Diego Gas & Electric Co. and Southern California Edison Company
[Docket No. ER98-1499-000]

Take notice that on January 16, 1998, the California Independent System Corporation (ISO), tendered for filing a Meter Service Agreement for ISO Metered Entities executed by the ISO and Pacific Gas and Electric Company for approval by the Commission.

The ISO states that this filing has been served on all parties listed on the official service list in the above referenced dockets, including the California Public Utilities Commission.

Comment date: February 17, 1998, in accordance with Standard Paragraph E at the end of this notice.

30. Pacific Gas & Electric Company, San Diego Gas & Electric Company and Southern California Edison Company
[Docket No. ER98-1500-000]

Take notice that on January 16, 1998, the California Independent System Corporation (ISO), tendered for filing a Meter Service Agreement for ISO Metered Entities executed by the ISO and Midway Sunset Cogeneration Company for approval by the Commission.

The ISO states that this filing has been served on all parties listed on the official service list in the above referenced dockets, including the California Public Utilities Commission.

Comment date: February 17, 1998, in accordance with Standard Paragraph E at the end of this notice.

31. Pacific Gas & Electric Company, San Diego Gas & Electric Co. and Southern California Edison Company

[Docket No. ER98-1501-0000]

Take notice that on January 16, 1998, the California Independent System Corporation (ISO), tendered for filing a Meter Service Agreement for ISO Metered Entities executed by the ISO and San Diego Gas and Electric Company for approval by the Commission.

The ISO states that this filing has been served on all parties listed on the official service list in the above referenced docket, including the California Public Utilities Commission.

Comment date: February 17, 1998, in accordance with Standard Paragraph E at the end of this notice.

32. Pacific Gas & Electric Company, San Diego Gas & Electric Co. and Southern California Edison Company

[Docket No. ER98-1502-000]

Take notice that on January 16, 1998, the California Independent System Corporation (ISO), tendered for filing a Meter Service Agreement for ISO Metered Entities executed by the ISO and Southern California Edison Company for approval by the Commission.

The ISO states that this filing has been served on all parties listed on the official service list in the above referenced docket, including the California Public Utilities Commission.

Comment date: February 17, 1998, in accordance with Standard Paragraph E at the end of this notice.

33. Pacific Gas & Electric Company, San Diego Gas & Electric Co. and Southern California Edison Company
[Docket No. ER98-1503-000]

Take notice that on January 16, 1998, the California Independent System Corporation (ISO), tendered for filing a Meter Service Agreement for ISO Metered Entities executed by the ISO and Texaco Exploration and Production Inc. for approval by the Commission.

The ISO states that this filing has been served on all parties listed on the official service list in the above referenced docket, including the California Public Utilities Commission.

Comment date: February 17, 1998, in accordance with Standard Paragraph E at the end of this notice.

Standard Paragraph

E. Any person desiring to be heard or to protest said filing should file a motion to intervene or protest with the Federal Energy Regulatory Commission, 888 First Street, N.E., Washington, D.C.

20426, in accordance with Rules 211 and 214 of the Commission's Rules of Practice and Procedure (18 CFR 385.211 and 18 CFR 385.214). All such motions or protests should be filed on or before the comment date. Protests will be considered by the Commission in determining the appropriate action to be taken, but will not serve to make protestants parties to the proceeding. Any person wishing to become a party must file a motion to intervene. Copies of these filings are on file with the Commission and are available for public inspection.

David P. Boergers,
Acting Secretary.

[FR Doc. 98-3290 Filed 2-9-98; 8:45 am]

BILLING CODE 6717-01-P

DEPARTMENT OF ENERGY

Federal Energy Regulatory Commission

[Docket No. CP98-132-000]

Northern Natural Gas Company; Notice of Intent to Prepare an Environmental Assessment for the Proposed D-Line Extension and Request for Comments on Environmental Issues

February 4, 1998.

The staff of the Federal Energy Regulatory Commission (FERC or Commission) will prepare an environmental assessment (EA) that will discuss the environmental impacts of the construction and operation of the facilities, about 9.6 miles of 30-inch-diameter pipeline loop known as the D-Line Extension Project.¹ This EA will be used by the Commission in its decision-making process to determine whether the project is in the public convenience and necessity.

Summary of the Proposed Project

Northern Natural Gas Company (Northern) wants to expand the capacity of its facilities in Steele and Rice Counties, Minnesota to transport an additional 40,000 million British thermal units (MMBtu) per day of natural gas to one industrial customer, Koch Energy Services. Northern seeks authority to construct and operate:

- 9.6 miles of 30-inch-diameter loop between its Owatonna and Fairbault Compressor Stations in Steele and Rice Counties, Minnesota.

¹ Northern Natural Gas Company's application was filed with the Commission under Section 7 of the Natural Gas Act and Part 157 of the Commission's regulations.

The location of the project facilities is shown in appendix 1.² If you are interested in obtaining procedural information, please write to the Secretary of the Commission.

Land Requirements for Construction

Construction of the proposed facilities would require a total of about 139 acres of land including extra work spaces for road crossings. All of this land would revert to its former agricultural use following construction. No new permanent right-of-way would be required.

The EA Process

The National Environmental Policy Act (NEPA) requires the Commission to take into account the environmental impacts that could result from an action whenever it considers the issuance of a Certificate of Public Convenience and Necessity. NEPA also requires us to discover and address concerns the public may have about proposals. We call this "scoping." The main goal of the scoping process is to focus the analysis in the EA on the important environmental issues. By this Notice of Intent, the Commission requests public comments on the scope of the issues it will address in the EA. All comments received are considered during the preparation of the EA. State and local government representatives are encouraged to notify their constituents of this proposed action and encourage them to comment on their areas of concern.

The EA will discuss impacts that could occur as a result of the Construction and operation of the proposed project under these general headings:

- geology and soils
- water resources, fisheries, and wetlands
- vegetation and wildlife
- hazardous waste
- land use
- cultural resources
- endangered and threatened species
- public safety

We will also evaluate possible alternatives to the proposed project or portions of the project, and make recommendations on how to lessen or avoid impacts on the various resource areas.

Our independent analysis of the issues will be in the EA. Depending on

² The appendices reference in this notice are not being printed in the *Federal Register*. Copies are available from the Commission's Public Reference and Files Maintenance Branch, 888 First Street, N.E., Washington, D.C. 20426, or call (202) 208-1317. Copies of the appendices were sent to all those receiving this notice in the mail.

the comments received during the scoping process, the EA may be published and mailed to Federal, state, and local agencies, public interest groups, interested individuals, affected landowners, newspapers, libraries, and the Commission's official service list for this proceeding. A comment period will be allotted for review if the EA is published. We will consider comments on the EA before we make our recommendations to the Commission.

Currently Identified Environmental Issues

We have already identified several issues that we think deserve attention based on a preliminary review of the proposed facilities and the environmental information provided by Northern. This preliminary list of issues may be changed based on your comments and our analysis.

- The productivity of a total of about 139 acres of agricultural land (including 78 acres of prime farmland soils) could be diminished due to the potential impacts of pipeline construction such as rutting and compaction.
- Agricultural drain tiles, if present, could be damaged.

Public Participation

You can make a difference by sending a letter addressing your specific comments or concerns about the project. You should focus on the potential environmental affects of the proposal, alternatives to the proposal (including alternative routes), and measures to avoid or lessen environmental impact. The more specific your comments, the more useful they will be. Please carefully follow these instructions to ensure that your comments are received in time and properly recorded:

- Send two copies of your letter to: David P. Boergers, Acting Secretary, Federal Energy Regulatory Commission, 888 First St., N.E., Room 1A, Washington, DC 20426;
- Label one copy of the comments for the attention of the Environmental Review and Compliance Branch, PR-11.2
- Reference Docket No. CP98-132-000; and
- Mail your comments so that they will be received in Washington, DC on or before March 6, 1998.

If you are interested in obtaining procedural information please write to the Secretary of the Commission.

Becoming an Intervenor

In addition to involvement in the EA scoping process, you may want to become an official party to the proceeding or become an "intervenor."

Among other things, intervenors have the right to receive copies of case-related Commission documents and filings by other intervenors. Likewise, each intervenor must provide copies of its filings to all other parties. If you want to become an intervenor you must file a motion to intervene according to Rule 214 of the Commission's Rules of Practice and Procedure (18 CFR 385.214) (see appendix 2).

The date for filing timely motions to intervene in this proceeding has passed. Therefore, parties now seeking to file late interventions must show good cause, as required by section 385.214(b)(3), why this time limitation should be waived. Environmental issues have been viewed as good cause for late intervention.

You do not need intervenor status to have your environmental comments considered.

David P. Boergers,
Acting Secretary.

[FR Doc. 98-3239 Filed 2-9-98; 8:45 am]

BILLING CODE 6717-01-M

ENVIRONMENTAL PROTECTION AGENCY

[FRL-5964-8]

Information Collection Request for the Land Disposal Restrictions Surface Impoundment Study

AGENCY: Environmental Protection Agency (EPA).

ACTION: Notice.

SUMMARY: In compliance with the Paperwork Reduction Act (44 U.S.C. 3501 *et seq.*), this document announces that EPA is planning to submit the following proposed Information Collection Request (ICR) to the Office of Management and Budget (OMB). Before submitting the ICR to OMB for review and approval, EPA is soliciting comments on specific aspects of the proposed information collection as described below.

DATES: Comments must be submitted on or before April 13, 1998.

ADDRESSES: Commenters must send an original and two copies of their comments referencing docket number F-98-SIIP-FFFFF to: RCRA Docket Information Center, Office of Solid Waste (5305G), U.S. EPA, 401 M Street, SW, Washington, D.C. 20460. Hand deliveries of comments should be made to the Arlington, VA, address below. Comments may also be submitted electronically through the Internet to: rcradocket@epamail.epa.gov. Comments in electronic format should also be

identified by the docket number F-98-SIIP-FFFF. All electronic comments must be submitted as an ASCII file avoiding the use of special characters and any form of encryption.

Commenters should not submit electronically any confidential business information (CBI). An original and two copies of CBI must be submitted under separate cover to: RCRA CBI Document Control Officer, Office of Solid Waste (5305W), U.S. EPA, 401 M Street, SW, Washington, D.C. 20460.

Public comments and supporting materials are available for viewing in the RCRA Information Center (RIC), located at Crystal Gateway I, First Floor, 1235 Jefferson Davis Highway, Arlington, VA. The RIC is open from 9:00 a.m. to 4:00 p.m., Monday through Friday, excluding federal holidays. To review docket materials, it is recommended that the public make an appointment by calling (703) 603-9230. The public may copy a maximum of 100 pages from any regulatory docket at no charge. Additional copies cost \$0.15/page. The index and some supporting materials are available electronically.

The ICR is available on the Internet. Follow these instructions to access the information electronically:

On the World Wide Web: <http://www.epa.gov/epaoswer/osw/laws-reg.htm#ldr>

On FTP:
ftp.epa.gov
Login: anonymous
Password: your Internet address
Files are located in /pub/epaoswer

The official record for this action will be kept in paper form. Accordingly, EPA will transfer all comments received electronically into paper form and place them in the official record, which will also include all comments submitted directly in writing.

EPA responses to comments, whether the comments are written or electronic, will be in a background document to a notice in the *Federal Register*. EPA will not immediately reply to commenters electronically other than to seek clarification of electronic comments that may be garbled in transmission or during conversion to paper form, as discussed above.

FOR FURTHER INFORMATION CONTACT: For general information, contact the RCRA Hotline at 1-800-424-9346 or TDD 1-800-553-7672 (hearing impaired). In the Washington, D.C., metropolitan area, call (703) 412-9810 or TDD (703) 412-3323. For more detailed information on specific aspects of this information collection, contact Peggy Vyas, Office of Solid Waste (5302W), U.S. EPA, 401 M Street, SW, Washington, D.C. 20460,

telephone: (703) 308-5477, E-mail: vyas.peggy@epamail.epa.gov.

SUPPLEMENTARY INFORMATION:

I. Background

The Land Disposal Program Flexibility Act (LDPPFA) of 1996 requires EPA to conduct a study characterizing risks to human health and the environment associated with management of decharacterized wastes¹ in impoundments that are part of Clean Water Act treatment systems. On July 25, 1996, EPA published a notice requesting draft methodologies that would reflect the conceptual design and objectives of the study, including the best method to collect data, data quality assurance/quality control, risk assessment, and peer review (see 61 FR 38684, July 25, 1996). EPA concurrently developed its own draft methodology, which the Agency intended to compare with draft methodologies received from commenters. EPA received eight public comments in response to the July 25, 1996 notice; six were fairly general and two were quite detailed. EPA used many of the comments in developing the methodology for this study. This methodology is described in detail in the background document for this notice, entitled "Background and Response to Comments Document: Surface Impoundment Study," available in the RCRA docket.

Two commenters stated that existing data are inadequate to conduct this study and that additional data would need to be collected. The Chemical Manufacturers Association (CMA) commented that "The study cannot be completed with existing data. * * * CMA is willing to assist in ensuring that current and usable data is collected." Union Carbide stated that "The survey should focus on collecting * * * site-specific information and supplementing it, as-needed [sic], with appropriate site-specific modeling. * * * Union Carbide understands and accepts that a survey using a case-by-case approach will may [sic] require more work and expense for owners and operators of surface impoundments than a generic national model would. We think the extra value is worth the extra work: regulatory agencies and the public need to understand real risks and actual regulatory circumstances rather than hypothetical cases."

EPA has chosen to design and implement a study that is consistent with these comments: a study which

characterizes risks at a representative sample of actual sites located across the country. To do so, we must first administer a "screener" survey to a representative sample of facilities, in order to locate those with surface impoundments that are within the study's scope. Then, for those facilities with surface impoundments within the study's scope, we would need to collect current, site-specific information from data sources in the public domain, and also rather detailed information which will be available only from the facility owners/operators, in order to perform the site-specific modeling suggested by these commenters. Thus, EPA expects to mail out the screener survey to approximately 1500 facilities to determine if they actually have surface impoundments that fall within the scope of the study. Upon identifying 415 facilities that respond positively to the screener questionnaire, EPA will then send those 415 facilities the more detailed information-gathering questionnaire.

An important note is that EPA has decided to expand the study's scope beyond that which was mandated in the original legislation. Although the LDPPFA only requires EPA to study decharacterized nonhazardous wastes, EPA believes it would be necessary to study the risks from surface impoundments managing non-decharacterized nonhazardous wastes as well, to provide comparison with a group of waste management units that are regulated in a similar manner. In addition, as a result of the re-negotiation of a consent decree between EPA and the Environmental Defense Fund (*EDF v. Reilly*, Cir. No. 89-0598, D.D.C.), EPA has now committed to studying the risks associated with air emissions from nonhazardous wastes managed in surface impoundments. That study is to be completed by March 26, 2001.

On April 30, 1997, EPA presented a proposed study methodology to a special subcommittee of the EPA Science Advisory Board (SAB)'s Environmental Engineering Committee. The purpose was to obtain peer review on: (1) the technical merits of the overall study structure; (2) the technical merits of the proposed risk assessment; and (3) use of technical experts/peer review. On May 1, 1997, the subcommittee gave EPA verbal feedback on the proposed approach. The written report from the subcommittee's peer review is expected to be available in 1998.

CMA expressed interest in assisting EPA with the study's implementation, and requested the opportunity to review and comment on the information-gathering questionnaire. After revising

¹ Decharacterized wastes are formerly characteristic wastes (wastes for which the hazardous characteristic of ignitability, corrosivity, reactivity, or toxicity has been removed).

the information-gathering questionnaire to reflect CMA's comments, EPA used this revised questionnaire in a pilot study, and received both comments and burden estimates from the seven facilities² that participated in the pilot study. EPA revised the information-gathering questionnaire again, upon completion of the pilot study. Both the screener questionnaire and the information-gathering questionnaire are part of the background document for this notice.

The proposed risk modeling framework, described in "Technical Memorandum—Proposed Risk Assessment Modeling Framework for the Surface Impoundment Study," is available in the RCRA docket for this notice. The model used in the pilot study, described in "Technical Memorandum—Modifications to the Pilot Study Model for the Surface Impoundment Study," is available in the RCRA docket for this notice.

The Agency also conducted a sensitivity analysis on the proposed risk modeling framework. The sensitivity analysis identifies the "risk-driving variables" and their relative importance in the model outputs. Copies of the sensitivity analysis, entitled "Technical Memorandum—Preliminary Sensitivity Analyses for the Surface Impoundment Study," are available in the RCRA docket for this notice.

An agency may not conduct or sponsor, and a person is not required to respond to, a collection of information unless it displays a currently valid OMB control number. The OMB control numbers for EPA's regulations are listed in 40 CFR Part 9 and 48 CFR Chapter 15.

II. Burden Statement

EPA estimates each respondent will take 4 hours to respond to the screener questionnaire, at a cost of \$193 per respondent. The total hour burden of the screener questionnaire is estimated to be 6000 hours. The total cost of the screener questionnaire is estimated to be \$288,750. EPA estimates each respondent will take 89.5 hours to respond to the information-gathering questionnaire, at a cost of \$4415 per respondent. The total hour burden of the information-gathering questionnaire is estimated to be 37,142.5 hours. The total cost of the information-gathering questionnaire is estimated to be \$1,832,225.

Burden means the total time, effort, or financial resources expended by persons

² Of the nine facilities (four CMA volunteers, one American Forest and Paper Association volunteer, and four non-volunteers) that were sent pilot questionnaires, seven responded.

to generate, maintain, retain, or disclose or provide information to or for a Federal agency. This includes the time needed to: review instructions, develop, acquire, install, and utilize technology and systems for the purposes of collecting, validating, and verifying information, processing and maintaining information, and disclosing and providing information; adjust the existing ways to comply with any previously applicable instructions and requirements; train personnel to be able to respond to a collection of information; search data sources; complete and review the collection of information; and transmit or otherwise disclose the information.

III. Request for Comment

The EPA solicits comments on: (i) whether the proposed collection of information is necessary for the proper performance of the functions of the Agency, including whether the information will have practical utility;

(ii) the accuracy of the Agency's estimate of the burden of the proposed collection of information, including the validity of the methodology and assumptions used;

(iii) the quality, utility, and clarity of the information to be collected; and

(iv) how to minimize the burden of the collection of information on those who are to respond, including through the use of appropriate automated electronic, mechanical, or other information technology, e.g., permitting electronic submission of responses.

Dated: February 3, 1998.

Elizabeth Cotsworth,
Acting Director Office of Solid Waste.
[FR Doc. 98-3324 Filed 2-9-98; 8:45 am]

BILLING CODE 6560-50-P

ENVIRONMENTAL PROTECTION AGENCY

[FRL-5964-4]

Ambient Air Monitoring Reference and Equivalent Methods; Receipt of Applications for Reference and Equivalent Method Determinations

AGENCY: Environmental Protection Agency.

ACTION: Notice of receipt of applications.

SUMMARY: The Environmental Protection Agency (EPA) is announcing that it has received applications from Rupprecht and Patashnick Company, Incorporated, Thermo Environmental Instruments, Incorporated, BGI, Incorporated, and Graseby Andersen for reference method determinations for their respective

PM_{2.5} particle samplers, and from Dasibi Environmental Corporation for an equivalent method determination for their Model 1108 Ozone Analyzer.

FOR FURTHER INFORMATION CONTACT:

Frank F. McElroy, Human Exposure and Atmospheric Sciences Division (MD-46), National Exposure Research Laboratory, U.S. EPA, Research Triangle Park, North Carolina 27711, (919) 541-2622.

SUPPLEMENTARY INFORMATION: Notice is given that EPA has received applications to determine if six new PM_{2.5} monitoring methods and a new continuous ozone analyzer method should be designated by the Administrator of the EPA as reference or equivalent methods under 40 CFR PART 53. Two applications were received on October 7, 1997 from Rupprecht and Patashnick Company, Incorporated, 25 Corporate Circle, Albany, New York 12203 for that Company's Partisol®-FRM Model 2000 (single) and Partisol®-FRM Model 2025 (sequential) PM-2.5 Air Samplers. An application was received on October 8, 1997 from Thermo Environmental Instruments, Incorporated, 8 West Forge Parkway, Franklin, Massachusetts 02038 regarding its Model 605/FH95-E Computer Assisted Particle Sampler for PM_{2.5}. Another application was received, also on October 8, 1997, from BGI, Incorporated, 58 Guinan Street, Waltham, Massachusetts 02154 for BGI's Model PQ-200 PM_{2.5} Ambient Fine Particle Sampler. And an application was received on January 8, 1998 from Graseby Andersen, 500 Technology Court, Smyrna, Georgia 30082 for that Company's Models RAAS2.5-100 (single) and RAAS2.5-300 (sequential) PM_{2.5} Samplers. Finally, an application was received on December 4, 1997 from Dasibi Environmental Corporation, 506 Paula Avenue, Glendale, California 91201 for Dasibi's Model 1108 Ozone Analyzer. If, after appropriate technical study, the Administrator determines that any or all of these methods should be designated as reference or equivalent methods, as appropriate, notice thereof will be published in a subsequent issue of the Federal Register.

Henry L. Longest II,

Acting Assistant Administrator for Research and Development.

[FR Doc. 98-3321 Filed 2-9-98; 8:45 am]

BILLING CODE 6560-50-M

ENVIRONMENTAL PROTECTION AGENCY

[FRL-5964-5]

Clean Air Act; Acid Rain Provisions

AGENCY: Environmental Protection Agency (EPA).

ACTION: Notice of the 1998 EPA SO₂ allowance auctions.

SUMMARY: Pursuant to Title IV of the Clean Air Act and 40 CFR part 73, the EPA is responsible for implementing a program to reduce emissions of sulfur dioxide (SO₂), a precursor of acid rain. The centerpiece of the SO₂ control program is the allocation of transferable allowances, or authorizations to emit SO₂, which are distributed in limited quantities for existing utility units and which eventually must be held by virtually all utility units to cover their SO₂ emissions. These allowances may be transferred among polluting sources and others, so that market forces may govern their ultimate use and distribution, resulting in the most cost-effective sharing of the emissions control burden. In addition, EPA is directed under section 416 of the Act to conduct annual auctions of a small portion of allowances (2.8%) withheld from the total allowances allocated to utilities each year. Auctions are expected to stimulate and support such a market in allowances and to provide a public source of allowances, particularly to new units for which no allowances are allocated. Today, the Acid Rain Division is giving notice of the sixth annual SO₂ allowance auctions. The regulation governing the auctions was promulgated on December 17, 1991 (40 CFR part 73, subpart E).

EPA has delegated the administration of the EPA allowance auctions to the Chicago Board of Trade (CBOT). The auctions will be conducted under the regulation cited above. Anyone can participate in the EPA auctions and bidders are not restricted as to the quantity or price of their bid. Allowances sold at the auctions will be sold to the highest bidder until no allowances remain. The 1998 auctions will consist of one "spot" auction and one "advance" auction. Allowances sold in the spot auction are useable for compliance beginning in 1998. Allowances sold in the 7-year advance auction are useable for compliance beginning in 2005. 150,000 allowances will be sold in the spot auction and 125,000 allowances will be sold in the 7-year advance auction. Bid Forms for the 1998 auctions must be received by the CBOT by the close of business on March 17, 1997. The auctions

themselves will be conducted on March 23, 1998, with the results announced on March 25.

CBOT will also sell in the 1998 auctions any spot or 7-year advance allowances that are offered by others holding allowances in EPA's Allowance Tracking System. However, offered allowances will be sold after the allowances that were withheld from the utilities, so offered allowances will consequently be sold at a lower price than the withheld allowances. Owners of offered allowances may set a minimum price for their allowances. To offer allowances in the EPA auctions, owners of allowances must submit a SO₂ Allowance Offer Form to EPA by the close of business on March 2, 1998. The auction regulation requires that offer forms be received by EPA no later than 15 business days prior to the date of the auctions.

ADDRESSES:

Regular mail: U.S. EPA Acid Rain Division (6204J), Attn: Auctions, 401 M St., S.W., Washington, DC 20460.

Overnight mail: US EPA Acid Rain Division (6204J), Attn: Auctions, 501 3rd Street, N.W., Washington, DC 20001.

Chicago Board of Trade, Attn: EPA Auctions, 141 W. Jackson Blvd., Suite 2240, Chicago, IL 60604.

FOR FURTHER INFORMATION: Information on bidding in the 1998 EPA auctions can be found in the brochure "How to Bid in the EPA SO₂ Allowance Auctions, Sixth Annual Auctions—March 23, 1998"; general information on the EPA auctions can be found in the "Acid Rain Program Allowance Auctions" fact sheet. These publications, as well as the forms needed to participate in the EPA auctions, can be obtained by calling the Acid Rain Hotline at (202) 564-9620, by writing to EPA at the address listed above, or by accessing the Acid Rain Program home page at <http://www.epa.gov/acidrain>.

Dated: January 28, 1998.

Janice K. Wagner,

Acting Director, Acid Rain Division.

[FR Doc. 98-3320 Filed 2-9-98; 8:45 am]

BILLING CODE 6560-50-P

ENVIRONMENTAL PROTECTION AGENCY

[FRL-5964-7]

Investigator-Initiated Grants: Requests for Applications

AGENCY: Environmental Protection Agency (EPA).

ACTION: Notice of request for applications.

SUMMARY: This document provides information on the availability of the fiscal year 1998 investigator-initiated grants program announcements, in which the areas of research interest, eligibility and submission requirements, evaluation criteria, and implementation schedule are set forth. Grants will be competitively awarded following peer review.

DATES: Receipt dates vary depending on the specific research area within the solicitation and are listed below.

FOR FURTHER INFORMATION CONTACT: U.S. Environmental Protection Agency, National Center for Environmental Research and Quality Assurance (8703R), 401 M Street, SW, Washington DC 20460, telephone (800) 490-9194. Each of the complete announcements can be accessed on the Internet from the EPA home page: <http://www.epa.gov/ncerqa>.

SUPPLEMENTARY INFORMATION: In its Requests for Applications (RFA) the U.S. Environmental Protection Agency (EPA) invites research grant applications in the following areas of special interest to its mission: (1) Environmental Statistics (joint with the National Science Foundation), and (2) Research and Monitoring Program on Ecological Effects of Environmental Stressors using Coastal Intensive Sites. EPA also announces a request for applications for a new program called Environmental Monitoring for Public Access and Community Tracking (EMPACT). Applications must be received as follows: March 16, 1998, for topic (1); April 1, 1998, for topic (2); and May 15, 1998 for EMPACT.

The RFAs provide relevant background information, summarize EPA's interest in the topic areas, and describe the application and review process.

Contact person for the Environmental Statistics RFA is Chris Saint (saint.chris@epamail.epa.gov), telephone 202-564-6909; for Research and Monitoring Program on Ecological Effects of Environmental Stressors using Coastal Intensive Sites is Barbara Levinson (levinson.barbara@epamail.epa.gov), telephone 202-564-6911; and for EMPACT is Barbara Karn (karn.barbara@epamail.epa.gov), telephone 202-564-6824.

Dated: February 2, 1998.

Henry L. Longest, II,
Acting Assistant Administrator for Research
and Development.

[FR Doc. 98-3315 Filed 2-9-98; 8:45 am]

BILLING CODE 6560-50-P

ENVIRONMENTAL PROTECTION AGENCY

[FRL-5964-6]

Investigator-Initiated Grants on Futures: Detecting the Early Signals

AGENCY: Environmental Protection
Agency (EPA).

ACTION: Notice.

SUMMARY: The purpose of this document is to solicit public comment on the appropriateness of the research topic, "Futures: Detecting the Early Signals," described in the draft Request for Applications (RFA). The Agency's Science Advisory Board has recommended EPA should move towards using futures research and analysis in its programs and activities, particularly strategic planning and budgeting. The draft RFA is part of EPA's response to this recommendation. In the draft RFA EPA's Office of Research and Development (ORD) invites research grant applications to develop innovative, scientific approaches for solving current and future environmental problems and to improve our understanding of environmental risk.

DATES: Comments are requested on the wording, scope, and appropriateness of the research topics presented in this draft RFA. Comments must be received on or before March 12, 1998. EPA plans to issue the RFA a month after the close of the comment period.

FOR FURTHER INFORMATION CONTACT: For questions or comments regarding the solicitation process, contact Dr. Robert Menzer, telephone number (202) 564-6849, EPA (8701R), 401 M Street, SW, Washington, DC 20460, electronic mail address:

menzer.robert@epamail.epa.gov. For questions or comments regarding the specific research topics, contact Dr. Roger Cortesi, telephone number (202) 564-6852, EPA (8701R), 401 M Street, SW, Washington, DC 20460, electronic mail address:

cortesi.roger@epamail.epa.gov.
SUPPLEMENTARY INFORMATION: EPA's National Center for Environmental Research and Quality Assurance (NCERQA) is preparing to issue a solicitation for research on futures. Funding for this solicitation will be

provided by EPA for a total of approximately \$1 million. We plan to award 6-8 grants, each with a project period of 1 year, under this solicitation.

NCERQA will receive, process, and distribute the proposals to the peer reviewers; convene the peer review sessions in conformance with existing EPA guidelines; and record the review discussion for each proposal. No EPA employees will serve as peer reviewers.

The description of the request for applications is as follows:

Futures: Detecting the Early Signals

Background

The question often arises whether serious environmental problems could be detected so that preventive or remedial actions could be generated sooner than they had been heretofore. Early awareness of an environmental problem would result in the ability to cope with a less serious problem, one easier and cheaper to handle. The possibility and value of early detection of environmental problems were the subject of the Environmental Protection Agency (EPA) Science Advisory Board's 1995 report, *Beyond the Horizon: Using Foresight to Protect the Environmental Future*. The report discusses why thinking about the future is important, possible systems of inquiry, and recommends that ". . . EPA should move towards using futures research and analysis in its programs and activities, particularly strategic planning and budgeting . . ." Specifically:

- "As much attention should be given to avoiding future problems as to controlling current ones," and
 - "EPA should establish a strong environmental futures capability that serves as an early warning system for emerging environmental problems."
- In its planning process the Office of Research and Development (ORD) has committed itself to "establish capability and mechanisms within EPA to anticipate and identify environmental or other changes that may portend future risk, integrate futures planning into ongoing programs, and promote coordinated preparation for and response to change."

Scope of Research

In this announcement EPA's Office of Research and Development (ORD) invites research grant applications to develop innovative, scientific approaches for identifying future environmental problems. EPA, in order to perform its mission better, wishes to find ways to identify possible emerging environmental problems and to start working on them before headlines have

emerged. This solicitation aims to try an approach to looking ahead in two areas: in the natural sciences and in socio-economics.

Specifically, EPA requests applications in:

A. Natural Sciences. The applicant should choose an area where there is scattered scientific data that could portend a future environmental problem, examine these scattered data, and write a synthesis giving possible interpretations. This paper should suggest which questions raised by the data need answering and which of these questions can be resolved by research. Key features in proposal evaluation will be: (1) the balance in the identified potential problem between seriousness of the problem and its "Chicken Little factor," and (2) the value of the possible proposed synthesis even if the suspected problem turns out to be minimal.

Examples of problems which might have profited from such early examination in the past include:

- acid rain
- stratospheric ozone depletion
- DDT and thin bird egg shells
- PCBs, environmental persistence and its effects

B. Socio-Economics. The applicant should examine possible changes in the way we (the USA, the industrialized nations, the world, etc.), in the next five to twenty years, will think, do things, live, consume, invent, reproduce, etc., and what effects these changes will have on environmental problems, on our mind set, on how we handle them, on the tools we will have available to handle them, on the costs and benefits of handling them, etc. Socioeconomic analyses can cover a variety of subjects (e.g., demographic changes, economic changes, environmental value changes, land use changes, etc.)

A key feature of the evaluation of the proposals will be the usefulness of the analyses and the analytical methods developed even if the views of what the future will bring turn out to be seriously wrong. The proposed studies and syntheses should, if possible, offer suggestions about what possible changes are important and identify such changes to the environment that could be monitored for early detection and correction.

It is anticipated that projects funded under this solicitation will involve literature investigation and analysis, discussions with colleagues, perhaps computer modeling, and crystal-ball gazing. The final product of the research will be a paper setting forth the problem, approaches to its solution, and an estimate of the resources needed to

effect the solution (e.g., the outline of a research plan).

Funding: Approximately \$1.0 million is expected to be available in Fiscal Year 1998 for award in this solicitation. The projected award may be up to \$150,000 for one year. Applicants will be expected to budget for and participate in a workshop on environmental futures with EPA scientists, other agency officials, and other grantees in Washington, DC, to report on their research activities and to discuss issues of mutual interest.

Eligibility

Academic and not-for-profit institutions located in the U.S., and state or local governments are eligible under all existing authorizations. Profit-making firms and other federal agencies are not eligible to receive grants from EPA under this program. Federal agencies, national laboratories funded by federal agencies (FFRDCs), and federal employees are not eligible to submit applications to this program and may not serve in a principal leadership role on a grant.

The final RFA will also include instructions to potential applicants on the specific format to be used for applications. These instructions will be similar to such instructions found in other EPA/ORD solicitations which may be reviewed on the Internet at <http://www.epa.gov/ncerqa>.

Dated: January 28, 1998.

Henry L. Longest, II,
Acting Assistant Administrator for Research and Development.

[FR Doc. 98-3322 Filed 2-9-98; 8:45 am]

BILLING CODE 6560-50-P

ENVIRONMENTAL PROTECTION AGENCY

[FRL-5964-9]

Notice of Teleconference, Board of Scientific Counselors (BOSC) Executive Committee Meeting

AGENCY: Environmental Protection Agency (EPA).

SUMMARY: Pursuant to the Federal Advisory Committee Act, Public Law 92-463, as amended (5 U.S.C., App. 2), notice is hereby given that the Environmental Protection Agency (EPA), Office of Research and Development (ORD), Board of Scientific Counselors (BOSC), will hold a teleconference on February 25, 1998. On Wednesday, February 25, the teleconference will begin at 11:30 a.m. and will adjourn at 1:30 p.m. All times noted are Eastern Time. The purpose of

the teleconference is for the BOSC to review the draft report of ORD's, National Center for Environmental Research and Quality Assurance (NCERQA). The call-in number will be 202/260-7280; 6655# will access the teleconference. The teleconference is open to the public. Any member of the public wishing to make a presentation at the teleconference should contact Shirley Hamilton, Designated Federal Officer, Office of Research and Development (8701R), 401 M Street, SW., Washington, DC 20460; by telephone at (202) 564-6853. In general, each individual making an oral presentation will be limited to a total of three minutes.

FOR FURTHER INFORMATION CONTACT: Shirley R. Hamilton, Designated Federal Officer, U.S. Environmental Protection Agency, Office of Research and Development, NCERQA (MC8701R), 401 M Street, SW., Washington, DC 20460, (202) 564-6854.

Dated: February 3, 1998.

J.K. Alexander,
Acting Assistant Administrator for Research and Development.

[FR Doc. 98-3323 Filed 2-9-98; 8:45 am]

BILLING CODE 6560-50-M

FEDERAL COMMUNICATIONS COMMISSION

Public Information Collection Requirements Submitted to Office of Management and Budget (OMB) for Review

February 4, 1998.

The Federal Communications Commission has submitted the following information collection requirements to OMB for review and clearance under the Paperwork Reduction Act of 1995, 44 U.S.C. Section 3507. Persons wishing to comment on the information collections should contact Timothy Fain, Office of Management and Budget, Room 10236, NEOB, Washington, D.C. 20503, (202) 395-3561. For further information, contact Judy Boley, Federal Communications Commission, (202) 418-0214.

Please note: The Commission has requested emergency review of the following collections by February 9, 1998 under the provisions of 5 CFR Section 1320.13.

Title: Federal-State Joint Board on Universal Service, CC Docket No. 96-45 (47 CFR 36.611-36.612 and 47 CFR Part 54).

Form No.: N/A.
OMB Control No.: 3060-0774.
Action: Revised collection.

Respondents: Business or other for-profit entities; individuals or households, state.

Estimated Annual Burden: 5,565,451 respondents; .32 hours per response (avg.); 1,801,570 hours total annual burden for all collections. See estimates provided below for burden for requirements for which approval is sought.

Needs and Uses: On December 30, 1997, the Commission released the *Fourth Order on Reconsideration* in Federal-Joint Board on Universal Service, CC Docket 96-45, Access Charge Reform, Price Cap Performance Review for Local Exchange Carriers, Transport Rate Structure and Pricing, End User Common Line Charge, CC Docket Nos. 96-262, 94-1, 91-213, 95-72 (Order). Following publication of the Commission's May 8th *Report and Order* on Universal Service, the Commission received significant comment from the public regarding universal service in the form of petitions for reconsideration, oppositions to those petitions, and comments on those petitions. In the Order, the Commission responded to various issues raised in the petitions for reconsideration and/or clarification of the Commission's May 8th *Report and Order* on Universal Service. Several of the rules adopted in the Order reduce existing reporting requirements or impose new reporting requirements.

a. *47 C.F.R. § 54.201(a)(2)—Submission of eligibility criteria.* Pursuant to section 214(e), a carrier must be designated an eligible telecommunications carrier by a state commission before receiving universal service support in accordance with section 254. A state commission that is unable to designate as an eligible telecommunications carrier, by January 1, 1998, a carrier that sought such designation before January 1, 1998, may, once it has designated such carrier, file with the Commission a petition for waiver of paragraph (a)(1) of this section requesting that the carrier receive universal service support retroactive to January 1, 1998. The state commission must demonstrate in its petition that exceptional circumstances prevented it from designating such carrier as an eligible telecommunications carrier by January 1, 1998. (No. of respondents: 100; avg. hours per response: 4 hours; total annual burden: 400 hours).

b. *Demonstration of Reasonable Steps.* Carriers also are encouraged to file with the Commission information demonstrating that they took reasonable steps to be designated as eligible telecommunications carriers by January 1, 1998. (No. of respondents: 50; avg.

hours per response: 1 hour; total annual burden: 50 hours).

c. **47 C.F.R. § 54.519—State telecommunications networks.** State telecommunications networks that secure discounts on eligible services on behalf of eligible schools and libraries must maintain records listing eligible schools and libraries, showing the basis on which eligibility determinations were made, and demonstrating the discount amount to which each eligible school and library is entitled. The state networks must direct the eligible schools and libraries to pay the discounted price for services and must comply with the competitive bid requirements established in 47 CFR § 54.504. (No. of respondents: 50; avg. hours per response: 4 hours; total annual burden: 200 hours).

d. **Streamlined application process for schools and libraries and for rural health care providers.** An eligible school or library will not be required to undergo the competitive bid process outlined in 47 CFR § 54.504(a) for a minor modification to a universal service contract as defined in 47 CFR § 54.500(h). An eligible school or library making a minor modification to a contract must submit an FCC Form 471 indicating the value of the proposed contract modification. An eligible school or library will not be required to undergo the competitive bid process outlined in 47 CFR § 54.504(a) if the eligible entity elects to order services from a master contract negotiated by a third party as defined in 47 CFR § 54.500(g). An eligible rural health care provider shall not be required to undergo the competitive bid process outlined in § 54.603 for a minor modification to a universal service contract. Such health care provider, however, shall be required to file an FCC Form 466 indicating the value of the proposed contract modification. An eligible rural health care provider shall not be required to undergo the competitive bid process outlined in 47 CFR § 54.603 if the eligible entity elects to order services from a master contract negotiated by a third party. (See Order, Section J, pps. 130–136). (No. of respondents: 16,000; avg. hours per response: 1 hour; total annual burden: 16,000 hours).

e. **47 CFR § 54.604—Existing contracts.** Rural health care providers bound by existing contracts for services shall not be required to comply with the competitive bid process outlined in 47 CFR § 54.603. (This rule reduces the total annual burden of Section 54.603(b)(1) by 1,000 burden hours).

f. **Obligation to notify underlying carrier.** Systems integrators that derive

de minimis amounts of revenue from the resale of telecommunications and small entities that qualify for the *de minimis* exemption are not required to contribute to universal service. They must, however, notify their underlying carriers that they constitute end users for universal service purposes. (No. of respondents: 1700; avg. hours per response: 1 hour; total annual burden: 1,700 hours).

All the requirements contained herein are necessary to implement the congressional mandate for universal service. These reporting requirements are necessary to calculate the contribution amount owed by each telecommunications carrier or to verify that particular carriers and other respondents are eligible to receive universal service support. The recordkeeping requirements should not be burdensome since most businesses ordinarily retain these types of documents.

Title: Changes to the Board of Directors of the National Exchange Carrier Association and the Federal-State Joint Board on Universal Service, CC Docket Nos. 97–21 and 96–45.

Form No.: FCC Form 457.

OMB Control No.: 3060–0785.

Action: Revised collection.

Respondents: Business or other for-profit entities.

Estimated Annual Burden: 4,000 respondents; 13.9 hours per response (avg.); 55,650 hours total annual burden all requirements.

Needs and Uses: On December 30, 1997, the Commission released the *Fourth Order on Reconsideration* in Federal-Joint Board on Universal Service, CC Docket 96–45, Access Charge Reform, Price Cap Performance Review for Local Exchange Carriers, Transport Rate Structure and Pricing, End User Common Line Charge, CC Docket Nos. 96–262, 94–1, 91–213, 95–72 (Order). Following publication of the Commission's May 8th *Report and Order* on Universal Service, the Commission received significant comment from the public regarding universal service in the form of petitions for reconsideration, oppositions to those petitions, and comments on those petitions. In the Order, the Commission responded to various issues raised in the petitions for reconsideration and/or clarification of the Commission's May 8th Report and Order on Universal Service. The Commission reconsidered certain aspects of the Universal Service Order and exempted additional entities from universal service contribution and reporting requirements. Broadcasters and schools, colleges, universities, rural health care providers, and systems

integrators that derive *de minimis* amounts of revenue from the resale of telecommunications will not be required to contribute to universal service. See 47 CFR Section 54.703. Entities whose annual contribution would be less than \$10,000 will not be required to contribute to universal service or comply with universal service reporting requirements. See 47 CFR Section 54.705.

The foregoing estimates include the time for reviewing instructions, searching existing data sources, gathering and maintaining the data needed, and completing and reviewing the burden estimates or any other aspect of the collection of information including suggestions for reducing the burden to the Federal Communications Commission, Performance Evaluation and Records Management, Paperwork Reduction Project, Washington, D.C. 20554.

Federal Communications Commission.

Magalie Roman Salas,

Secretary.

[FR Doc. 98–3350 Filed 2–9–98; 8:45 am]

BILLING CODE 6712-01-P

FEDERAL DEPOSIT INSURANCE CORPORATION

Sunshine Act Meeting; Notice of a Matter To Be Withdrawn From Consideration at an Agency Meeting and; Notice of Matters Being Moved From the Summary Agenda to the Discussion Agenda

Pursuant to the provisions of the "Government in the Sunshine Act" (5 U.S.C. 552b), notice is hereby given that the following matter will be withdrawn from the "Discussion Agenda" at the Federal Deposit Insurance Corporation's Board of Directors open meeting scheduled to be held at 10:00 a.m. on Tuesday, February 10, 1998:

Memorandum and resolution regarding General Counsel Opinion No. 10.

In addition, the following matters will be moved from the "Summary Agenda" to the "Discussion Agenda:"

Memorandum and resolution regarding final amendments to Part 329—Interest on Deposits.

Memorandum and resolution regarding final amendments to Part 357—Determination of Economically Depressed Regions.

Dated: February 5, 1998.

Federal Deposit Insurance Corporation.
Robert E. Feldman,
Executive Secretary.
 [FR Doc. 98-3400 Filed 2-6-98; 10:27 a.m.]
BILLING CODE 6714-01-M

FEDERAL DEPOSIT INSURANCE CORPORATION

Sunshine Act Meeting

Pursuant to the provisions of the "Government in the Sunshine Act" (5 U.S.C. 552b), notice is hereby given that the Federal Deposit Insurance Corporation's Board of Directors will meet in open session at 10 a.m. on Tuesday, February 10, 1998, to consider the following matters:

Summary Agenda

- No substantive discussion of the following items is anticipated. These matters will be resolved with a single vote unless a member of the Board of Directors requests that an item be moved to the discussion agenda.
- Disposition of minutes of previous Board of Directors' meetings.
- Reports of actions taken pursuant to authority delegated by the Board of Directors.
- Fourth Quarter 1997 Investment Report. Memorandum and resolution re: Federal Financial Institutions Examination Council Supervisory Policy—Repurchase Agreements of Depository Institutions with Securities Dealers and Others.
- Memorandum and resolution re: Statement of the Federal Financial Supervisory Agencies Regarding the Community Reinvestment Act.
- Memorandum and resolution re: Final Amendments to Part 329—Interest on Deposits.
- Memorandum and resolution re: Final Amendments to Part 357—Determination of Economically Depressed Regions.

Discussion Agenda

- Memorandum and resolution re: General Counsel Opinion No. 10 which interprets charges constituting "interest" for purposes of section 24 of the Federal Deposit Insurance Act.
 - Memorandum and resolution re: Joint Statement of Policy on Administrative Enforcement of the Truth in Lending Action-Restitution.
- The meeting will be held in the Board Room on the sixth floor of the FDIC Building located at 550-17th Street, N.W., Washington, D.C.
- The FDIC will provide attendees with auxiliary aids (e.g., sign language interpretation) required for this meeting.

Those attendees needing such assistance should call (202) 416-2449 (Voice); (202) 416-2004 (TTY), to make necessary arrangements.

Requests for further information concerning the meeting may be directed to Mr. Robert E. Feldman, Executive Secretary of the Corporation, at (202) 898-6757.

Dated: February 3, 1998.
 Federal Deposit Insurance Corporation.
Robert E. Feldman,
Executive Secretary.
 [FR Doc. 98-3493 Filed 2-6-98; 2:46 pm]
BILLING CODE 6714-01-M

FEDERAL MARITIME COMMISSION

Notice of Agreement(s) Filed

The Commission hereby gives notice of the filing of the following agreement(s) under the Shipping Act of 1984.

Interested parties can review or obtain copies of agreements at the Washington, DC offices of the Commission, 800 North Capitol Street, NW., Room 962. Interested parties may submit comments on an agreement to the Secretary, Federal Maritime Commission, Washington, DC 20573, within 10 days of the date this notice appears in the **Federal Register**.

Agreement No.: 202-010776-110.
Title: Asia North America Eastbound Rate Agreement.

Parties:

American President Lines, Ltd.
 APL Co. Pte Ltd.
 Hapag-Lloyd Container Linie GmbH
 Kawasaki Kisen Kaisha, Ltd.
 A.P. Moller-Maersk Line
 Mitsui O.S.K. Lines, Ltd.
 Neptune Orient Lines, Ltd.
 Nippon Yusen Kaisha Line
 Orient Overseas Container Line, Inc.
 P&O Nedlloyd Limited
 P&O Nedlloyd B. V.
 Sea-Land Service, Inc.

Synopsis: The proposed modification would delete authority in Article 14 and related provisions of the Agreement that permit, upon a three quarters majority vote of those members present and entitled to vote, two or more member lines to jointly enter into service contracts with shippers.

Agreement No.: 203-011609.
Title: The TransPacific Bridge Agreement.

Parties: COSCO/KL TransPacific Vessel Sharing Agreement (FMC Agreement No. 217-011606), K-Line/Yangming TransPacific Rationalization and Space Charter Arrangement (FMC Agreement No. 232-011514).

Synopsis: The proposed agreement would allow the signatories of the underlying agreements to discuss and coordinate their container liner services in the trade between ports on the West Coast of the United States and inland points and ports and points in Asia. The agreement does not authorize discussion of or agreement on rates and charges, joint tariffs, or joint terminal operations. The parties have requested shortened review.

Agreement No.: 217-011610.
Title: Maersk/OOCL Space Charter Agreement.

Parties: A.P. Moller-Maersk Line, Orient Overseas Container Line.

Synopsis: The proposed Agreement authorizes Maersk to charter space to OOCL in the trade from ports in California and U.S. inland points served via those ports and ports and points in Northern Europe. The parties are also authorized to agree on administrative matters in implementing their agreement. The parties have requested expedited review.

Dated: February 5, 1998.
 By Order of the Federal Maritime Commission.

Joseph C. Polking,
Secretary.
 [FR Doc. 98-3347 Filed 2-9-98; 8:45 am]
BILLING CODE 6730-01-M

FEDERAL MARITIME COMMISSION

Ocean Freight Forwarder License Applicants

Notice is hereby given that the following applicants have filed with the Federal Maritime Commission applications for licenses as ocean freight forwarders pursuant to section 19 of the Shipping Act of 1984 (46 U.S.C. app. 1718 and 46 CFR 510).

Persons knowing of any reason why any of the following applicants should not receive a license are requested to contact the office of Freight Forwarders, Federal Maritime Commission, Washington, D.C. 20573.

A.T.M.C. Inc., 2208 Northwest Market, Suite 505, Seattle, WA 98107,
 Officers: Robert E. Maurer, President;
 Allen T. Maurer, Vice President.

Dated: February 4, 1998.
Joseph C. Polking,
Secretary.
 [FR Doc. 98-3258 Filed 2-9-98; 8:45 am]
BILLING CODE 6730-01-M

FEDERAL RESERVE SYSTEM**Change in Bank Control Notices; Acquisitions of Shares of Banks or Bank Holding Companies**

The notificants listed below have applied under the Change in Bank Control Act (12 U.S.C. 1817(j)) and § 225.41 of the Board's Regulation Y (12 CFR 225.41) to acquire a bank or bank holding company. The factors that are considered in acting on the notices are set forth in paragraph 7 of the Act (12 U.S.C. 1817(j)(7)).

The notices are available for immediate inspection at the Federal Reserve Bank indicated. The notices also will be available for inspection at the offices of the Board of Governors. Interested persons may express their views in writing to the Reserve Bank indicated for that notice or to the offices of the Board of Governors. Comments must be received not later than February 24, 1998.

A. Federal Reserve Bank of Chicago (Philip Jackson, Applications Officer) 230 South LaSalle Street, Chicago, Illinois 60690-1413:

1. *JMP Family Investments, L.P. and MJD Family Investments, L.P.*, Newman, Illinois; to acquire voting shares of Longview Capital Corporation, Newman, Illinois, and thereby indirectly acquire Longview State Bank, Newman, Illinois; First National Bank of Ogden, Ogden, Illinois; State Bank of Chrisman, Chrisman, Illinois; and First National Bank of Georgetown, Georgetown, Illinois.

2. *Craig W. Sandahl*, Reno, Nevada; to acquire additional voting shares of Swea City Bancorporation, Inc., Swea City, Iowa, and thereby indirectly acquire shares of Bank Plus, Estherville, Iowa.

Board of Governors of the Federal Reserve System, February 4, 1998.

Jennifer J. Johnson,
Deputy Secretary of the Board.

[FR Doc. 98-3215 Filed 2-9-98; 8:45 am]

BILLING CODE 6210-01-F

FEDERAL RESERVE SYSTEM**Formations of, Acquisitions by, and Mergers of Bank Holding Companies**

The companies listed in this notice have applied to the Board for approval, pursuant to the Bank Holding Company Act of 1956 (12 U.S.C. 1841 *et seq.*) (BHC Act), Regulation Y (12 CFR Part 225), and all other applicable statutes and regulations to become a bank holding company and/or to acquire the assets or the ownership of, control of, or the power to vote shares of a bank or

bank holding company and all of the banks and nonbanking companies owned by the bank holding company, including the companies listed below.

The applications listed below, as well as other related filings required by the Board, are available for immediate inspection at the Federal Reserve Bank indicated. The application also will be available for inspection at the offices of the Board of Governors. Interested persons may express their views in writing on the standards enumerated in the BHC Act (12 U.S.C. 1842(c)). If the proposal also involves the acquisition of a nonbanking company, the review also includes whether the acquisition of the nonbanking company complies with the standards in section 4 of the BHC Act. Unless otherwise noted, nonbanking activities will be conducted throughout the United States.

Unless otherwise noted, comments regarding each of these applications must be received at the Reserve Bank indicated or the offices of the Board of Governors not later than March 6, 1998.

A. Federal Reserve Bank of Atlanta (Lois Berthaume, Vice President) 104 Marietta Street, N.W., Atlanta, Georgia 30303-2713:

1. *Flag Financial Corporation*, LaGrange, Georgia; to become a bank holding company by acquiring 100 percent of the voting shares of Middle Georgia Bankshare, Inc., Unadilla, Georgia, and thereby indirectly acquire Citizens Bank, Vienna, Georgia.

In connection with this application, Applicant has also applied to acquire First Federal Savings Bank of LaGrange, LaGrange, Georgia, and thereby indirectly continue to engage in operating a thrift savings association, pursuant to § 225.28(b)(4)(ii) of the Board's Regulation Y.

B. Federal Reserve Bank of St. Louis (Randall C. Sumner, Vice President) 411 Locust Street, St. Louis, Missouri 63102-2034:

1. *Chambers Bancshares Inc.*, Danville, Arkansas; to acquire 100 percent of the voting shares of Community Investment, Inc., Elkins, Arkansas, and thereby indirectly acquire Bank of Elkins, Elkins, Arkansas.

2. *Union Planters Corporation*, Memphis, Tennessee, and its subsidiary, Union Planters Holding Corporation, Memphis, Tennessee; to acquire 100 percent of the voting shares of First National Bancshares of Wetumpka, Inc., Wetumpka, Alabama, and thereby indirectly acquire First National Bank, Wetumpka, Alabama.

C. Federal Reserve Bank of Dallas (Genie D. Short, Vice President) 2200 North Pearl Street, Dallas, Texas 75201-2272:

1. *Shamrock Bancshares, Inc.*, Shamrock, Texas, and Shamrock Delaware Financial, Inc., Dover, Delaware; to become bank holding companies by acquiring 100 percent of the voting shares of The First National Bank of Shamrock, Shamrock, Texas.

D. Federal Reserve Bank of San Francisco (Maria Villanueva, Manager of Analytical Support, Consumer Regulation Group) 101 Market Street, San Francisco, California 94105-1579:

1. *Zions Bancorporation*, Salt Lake City, Utah; to merge with FP Bancorp, Inc., Escondido, California, and thereby indirectly acquire First Pacific National Bank, Escondido, California.

Board of Governors of the Federal Reserve System, February 4, 1998.

Jennifer J. Johnson,
Deputy Secretary of the Board.
[FR Doc. 98-3214 Filed 2-9-98; 8:45 am]
BILLING CODE 6210-01-F

FEDERAL RESERVE SYSTEM**Notice of Proposals to Engage in Permissible Nonbanking Activities or to Acquire Companies that are Engaged in Permissible Nonbanking Activities; Correction**

This notice corrects a notice (FR Doc. 98-2632) published on pages 5541 and 5542 of the issue for Tuesday, February 3, 1998.

Under the Federal Reserve Bank of New York heading, the entry for Royal Bank of Canada, Montreal, Canada, is revised to read as follows:

A. Federal Reserve Bank of New York (Betsy Buttrill White, Senior Vice President) 33 Liberty Street, New York, New York 10045-0001:

1. *Royal Bank of Canada*, Montreal, Canada; to acquire through Integron Financial Network, LLC, Atlanta, Georgia, warrants to acquire up to 15.38 percent of the outstanding shares of CheckFree Corporation, Norcross, Georgia, and thereby engage in providing data processing and data transmission services, pursuant to § 225.28(b)(14) of the Board's Regulation Y.

Comments on this application must be received by February 17, 1998.

Board of Governors of the Federal Reserve System, February 4, 1998.

Jennifer J. Johnson,
Deputy Secretary of the Board.
[FR Doc. 98-3216 Filed 2-9-98; 8:45 am]
BILLING CODE 6210-01-F

**GENERAL SERVICES
ADMINISTRATION****Aircraft Management Policy Advisory
Board (AMPAB) of the
Governmentwide Policy Board****Meeting Notice**

February 3, 1998.

Notice is hereby given that the General Services Administration (GSA) Aircraft Management Policy Advisory Board (AMPAB) of the Governmentwide Policy Board will meet from 10:00 am to 5:00 pm on Wednesday, February 25, 1998 at the American Institute of Architecture, 1735 New York Avenue, NW, Washington, DC 20405. Notice is required by the Federal Advisory Committee Act, 5 U.S.C. App. 2, and the implementing regulation, 41 CFR 101-6.

The purpose of the meeting is to provide a forum to discuss government aircraft management policy. The agenda for this meeting will include discussions of and recommendations regarding the state of aviation safety among the several agencies operating government aircraft; the applicability of Federal Aviation Regulations to government aircraft; the role of GSA in federal aircraft management including, specifically, the responsibilities, authority and goals of the Interagency Committee for Aviation Policy (ICAP) and the efficacy of the Federal Aircraft Management Information System (FAMIS); and other such matters as may be brought before the Board.

The meeting will be open to the public. The public is hereby afforded the opportunity to submit written statements and to speak at the meeting.

For further information, contact Marty College, (202) 208-7420, Executive Assistant to the GSA Aircraft Management Policy Advisory Board.

Dated: February 4, 1998.

Beverly J. Sharkey,*Designated Federal Officer.*

[FR Doc. 98-3283 Filed 2-9-98; 8:45 am]

BILLING CODE 6620-BR-M

announces the following committee meeting.

Name: Breast and Cervical Cancer Early Detection and Control Advisory Committee.

Times and Dates: 9 a.m.-4:45 p.m., February 24, 1998. 9 a.m.-12 noon, February 25, 1998.

Place: Sheraton Four Points Hotel, 1850 Cotillion Drive, Atlanta, Georgia 30338, telephone 770/394-5000.

Status: Open to the public, limited only by the space available. The meeting room accommodates approximately 50 people.

Purpose: This committee is charged with providing advice and guidance to the Secretary, the Assistant Secretary for Health, and the Director of CDC, regarding the early detection and control of breast and cervical cancer and to evaluate the Department's current breast and cervical cancer early detection and control activities.

Matters To Be Discussed: The discussion will focus on treatment issues in the National Breast and Cervical Cancer Early Detection Program and an overview of the Battelle Study on Treatment and Follow-up.

Persons wishing to make oral presentations at the meeting should contact Ms. Rebecca Wolf (770/488-3012) or Ms. Karen Norton (770/488-3013) by 4 p.m., February 9, 1998. All requests will be limited to five minutes and should contain the name of the presenter and an outline of the issues to be addressed. At least 25 copies of the presentation and any visual aids to be used at the meeting should be given to Ms. Norton prior to the meeting.

Agenda items are subject to change as priorities dictate.

An unavoidable administrative delay prevented meeting the 15-day publication requirement.

Contact Person for Additional Information: Rebecca B. Wolf, Division of Cancer Prevention and Control, National Center for Chronic Disease Prevention and Health Promotion, CDC, 4770 Buford Highway, NE, M/S K-64, Atlanta, Georgia 30341-3724, telephone 770/488-3012.

Dated: February 4, 1998.

Carolyn J. Russell,*Director, Management Analysis and Services Office, Centers for Disease Control and Prevention (CDC).*

[FR Doc. 98-3415 Filed 2-9-98; 8:45 am]

BILLING CODE 4163-18-P

**DEPARTMENT OF HEALTH AND
HUMAN SERVICES****Centers for Disease Control and
Prevention****Advisory Committee on Childhood
Lead Poisoning Prevention: Meeting**

In accordance with section 10(a)(2) of the Federal Advisory Committee Act (Pub. L. 92-463), the National Center for Environmental Health (NCEH) of the Centers for Disease Control and Prevention (CDC) announces the following committee meeting.

Name: Advisory Committee on Childhood Lead Poisoning Prevention.

Times and Dates: 8:30 a.m.-5 p.m., February 24, 1998. 8:30 a.m.-3 p.m., February 25, 1998.

Place: Radisson Plaza Hotel at Mark Center, 5000 Seminary Road, Alexandria, Virginia 22311, telephone 703/845-1010.

Status: Open to the public, limited only by the space available. The meeting room accommodates approximately 50 people.

Purpose: The Committee shall provide advice and guidance to the Secretary; the Assistant Secretary for Health; and the Director, CDC, regarding new scientific knowledge and technological developments and their practical implications for childhood lead poisoning prevention efforts. The Committee shall also review and report regularly on childhood lead poisoning prevention practices and recommend improvements in national childhood lead poisoning prevention efforts.

Matters To Be Discussed: Agenda items include: mission statements of the National Center for Environmental Health (NCEH), Division of Environmental Hazards and Health Effects (DEHHE), Lead Poisoning Prevention Branch (LPPB); the Committee: historical overview, new charter and role, policies and procedures, and future directions; Lead Program—Budget and Legislation; Lead Epidemiology and Research; Childhood Blood Lead Surveillance overview; laboratory overview; and a geographic information systems overview.

Agenda items are subject to change as priorities dictate.

Opportunities will be provided during the meeting for oral comments. Depending on the time available and the number of requests, it may be necessary to limit the time of each presenter.

An unavoidable administrative delay prevented meeting the 15-day publication requirement.

Contact Person for More Information: Barbara Nelson, Program Analyst, LPPB, DEHHE, NCEH, CDC, 4770 Buford Highway, NE, M/S F-42, Atlanta, Georgia 30341-3724, telephone 770/488-7272, fax 770/488-7335.

Dated: February 4, 1998.

Carolyn J. Russell,*Director, Management Analysis and Services Office, Centers for Disease Control and Prevention (CDC).*

[FR Doc. 98-3410 Filed 2-9-98; 8:45 am]

BILLING CODE 4163-18-P

**DEPARTMENT OF HEALTH AND
HUMAN SERVICES****Food and Drug Administration****Advisory Committees; Renewals**

AGENCY: Food and Drug Administration, HHS.

ACTION: Notice.

SUMMARY: The Food and Drug Administration (FDA) announces the renewal of certain FDA advisory

**DEPARTMENT OF HEALTH AND
HUMAN SERVICES****Centers for Disease Control and
Prevention****Breast and Cervical Cancer Early
Detection and Control Advisory
Committee: Meeting**

In accordance with section 10(a)(2) of the Federal Advisory Committee Act (Pub. L. 92-463), the Centers for Disease Control and Prevention (CDC)

committees by the Commissioner of Food and Drugs (the Commissioner). The Commissioner has determined that it is in the public interest to renew the charters of the committees listed below for an additional 2 years beyond charter

expiration date. The new charters will be in effect until the dates of expiration listed below. This notice is issued under the Federal Advisory Committee Act of October 6, 1972 (Pub. L. 92-463 (5 U.S.C. app. 2)).

DATES: Authority for these committees will expire on the dates indicated below unless the Commissioner formally determines that renewal is in the public interest.

Name of committee	Date of expiration
Antiviral Drugs Advisory Committee	February 15, 1999
National Mammography Quality Assurance Advisory Committee	July 6, 1999
Nonprescription Drugs Advisory Committee	August 27, 1999
Advisory Committee on Special Studies Relating to the Possible Long-Term Health Effects of Phenoxy Herbicides and Contaminants	December 2, 1999
Food Advisory Committee	December 18, 1999
Vaccines and Related Biological Products Advisory Committee	December 31, 1999

FOR FURTHER INFORMATION CONTACT:

Donna M. Combs, Committee Management Office (HFA-306), Food and Drug Administration, 5600 Fishers Lane, Rockville, MD 20857, 301-827-4820.

Dated: February 4, 1998.

Michael A. Friedman,
Lead Deputy Commissioner for the Food and Drug Administration.

[FR Doc. 98-3295 Filed 2-9-98; 8:45 am]

BILLING CODE 4160-01-F

DEPARTMENT OF HEALTH AND HUMAN SERVICES

Food and Drug Administration

[Docket No. 98F-0052]

Monsanto Co.; Filing a Food Additive Petition

AGENCY: Food and Drug Administration, HHS.

ACTION: Notice.

SUMMARY: The Food and Drug Administration (FDA) is announcing that Monsanto Co. has filed a petition proposing that the food additive regulations be amended to provide for the safe use of L-Phenylalanine, N-[N-(3,3-dimethylbutyl)-L- α -aspartyl]-, 1-methyl ester for use as a tabletop sweetener. Monsanto Co. also proposes that this additive be identified as neotame.

DATES: Written comments on the petitioner's environmental assessment by March 12, 1998.

ADDRESSES: Submit written comments to the Dockets Management Branch (HFA-305), Food and Drug Administration, 12420 Parklawn Dr., rm. 1-23, Rockville, MD 20857.

FOR FURTHER INFORMATION CONTACT: Blondell Anderson, Center for Food Safety and Applied Nutrition (HFS-

206), Food and Drug Administration, 200 C St. SW., Washington, DC 20204, 202-418-3106.

SUPPLEMENTARY INFORMATION: Under the Federal Food, Drug, and Cosmetic Act (sec. 409(b)(5) (21 U.S.C. 348(b)(5))), notice is given that a food additive petition (FAP 8A4580) has been filed by Monsanto Co., 5200 Old Orchard Rd., Skokie, IL 60077. The petition proposes to amend the food additive regulations in 21 CFR part 172 to provide for the safe use of L-Phenylalanine, N-[N-(3,3-dimethylbutyl)-L- α -aspartyl]-, 1-methyl ester as a tabletop sweetener and for the additive to be identified as neotame.

The potential environmental impact of this action is being reviewed. To encourage public participation consistent with regulations promulgated under the National Environmental Policy Act (40 CFR 1501.4(b)), the agency is placing the environmental assessment submitted with the petition that is the subject of this notice on display at the Dockets Management Branch (address above) for public review and comment. Interested persons may, on or before March 12, 1998, submit to the Dockets Management Branch (address above) written comments. Two copies of any comments are to be submitted, except that individuals may submit one copy. Comments are to be identified with the docket number found in brackets in the heading of this document. Received comments may be seen in the office above between 9 a.m. and 4 p.m., Monday through Friday. FDA will also place on public display any amendments to, or comments on, the petitioner's environmental assessment without further announcement in the **Federal Register**. If, based on its review, the agency finds that an environmental impact statement is not required and this petition results in a regulation, the notice of availability of the agency's

finding of no significant impact and the evidence supporting that finding will be published with the regulation in the **Federal Register** in accordance with 21 CFR 25.40(c).

Dated: January 23, 1998.

Laura M. Tarantino,
Acting Director, Office of Premarket Approval, Center for Food Safety and Applied Nutrition.

[FR Doc. 98-3296 Filed 2-9-98; 8:45 am]

BILLING CODE 4160-01-F

DEPARTMENT OF HOUSING AND URBAN DEVELOPMENT

[Docket No. FR-4256-N-03]

Notice of Funding Availability for the HUD-Administered Small Cities Community Development Block Grant (CDBG) Program—Fiscal Year 1997 and Fiscal Year 1998; and the Section 108 Loan Guarantee Program for Small Communities in New York State; Amendment and Extension of Application Deadline

AGENCY: Office of the Assistant Secretary for Community Planning and Development, HUD.

ACTION: Amendment to notice of funding availability and extension of application deadline.

SUMMARY: This notice extends the application deadline for the combined fiscal year (FY) 1997 and FY 1998 NOFA for the HUD-Administered Small Cities Community Development Block Grant (CDBG) Program for Small Communities in New York State, published in the **Federal Register** on December 16, 1997 (62 FR 65970). This notice establishes the application deadline to be April 2, 1998. This notice also amends that NOFA to clarify the special limitations for multiyear plan recipients.

DATES: Applications are due by April 2, 1998.

FOR FURTHER INFORMATION CONTACT:

Joseph A. D'Agosta, Director, Office of Community Planning and Development, Department of Housing and Urban Development, 26 Federal Plaza, New York, NY 10278-0068; telephone (212) 264-0771. Hearing- or speech-impaired persons may call (212) 264-0927 (TTY). (These numbers are not toll-free numbers.)

SUPPLEMENTARY INFORMATION: The Notice of Funding Availability (NOFA) for the HUD-Administered Small Cities Community Development Block Grant (CDBG) Program—Fiscal Year (FY) 1997 and FY 1998, and the Section 108 Loan Guarantee Program for Small Communities in New York State was published in the *Federal Register* on December 16, 1997 (62 FR 65970). Recent ice storms in the northeast part of the United States have resulted in ten New York counties receiving Federal disaster declarations. In response to this emergency, HUD is extending the application deadline from March 2, 1998, to April 2, 1998, to allow these counties and other affected communities sufficient time to complete applications that may include activities related to the damage from the ice storms.

Furthermore, the December 16, 1997 NOFA provided that the application kits would be available from HUD's New York or Buffalo offices at least 45 days prior to the application due date. However, HUD has been unable to provide the application kits as early as planned. Therefore, HUD is extending the application deadline from March 2, 1998, to April 2, 1998, in order to afford communities sufficient time to complete applications once the kits are available.

In addition, applicants should note that HUD is making funds available to disaster-affected areas in New York (which are all at this time under the jurisdiction of the Buffalo field office) under the noncompetitive Imminent Threat grant provisions of 24 CFR 570.424 (see also Section I.B.2. of the December 16, 1997 NOFA regarding imminent threats (62 FR 65972)). In response to a request from the Governor of New York and on-site assessments by HUD's emergency teams, HUD has announced that it is setting aside up to \$12 million of FY 1997 and FY 1998 funds for such purposes, pursuant to the provisions cited above. Imminent Threat grant applications are not subject to the procedures and deadlines of the December 16, 1997 NOFA. Eligible applicants should contact the Buffalo field office for information about

procedures applicable to such grants. However, counties and other eligible units of general local government that receive CDBG assistance under the Imminent Threat provisions of § 570.424 will not be prejudiced in their application for competitive CDBG Small Cities grant assistance announced in the December 16, 1997 NOFA.

In addition to extending the application deadline until April 2, 1998, this notice also amends the December 16, 1997 NOFA to clarify the special limitations for multiyear plan recipients. Section I.D.2.c. of that NOFA (62 FR 65974, 1st column), regarding Single Purpose grants, and special limitations for multiyear plan recipients, provided information on how the grant limitations apply to applicants with approved multiyear plans that wish to apply for and receive their FY 1997 increment. This notice amends the NOFA to clarify that, to the extent to which a recipient with previously-approved multiyear plan received approval for a FY 1997 and/or FY 1998 multiyear plan increment in an amount that is less than the \$400,000 (or, in the case of counties, \$600,000) grant limits established in the NOFA, such recipient may also, in addition to the application(s) to be submitted for the FY 1997 or FY 1998 multiyear plan increment, submit an application(s) to be rated and ranked with all other competitive applications for up to the difference between the amount of the applicable established grant limit and the amount of the FY 1997 or FY 1998 multiyear plan application submission.

For example, if a community was approved for a multiyear plan of \$250,000 for FY 1997 and \$250,000 for FY 1998, that community may submit two additional applications for \$150,000 each (the \$400,000 grant limit minus the \$250,000 amount approved for the multiyear plan increment equals \$150,000), one for FY 1997 and one for FY 1998, to be scored and ranked competitively with all other competitive applications submitted. Thus, in this example, the community could submit up to four (4) separate applications—two applications for \$250,000 each for the FY 1997 and FY 1998 previously approved multiyear plan, and two applications for \$150,000 each for the FY 1997/FY 1998 competition. HUD is aware of two communities and two counties that fall into this category, and is amending this NOFA after an inquiry from one of the counties. HUD had not taken these facts into consideration when it originally published the NOFA on December 16, 1997, and believes that all communities should have the same opportunity to receive a grant up to the

applicable grant limits established in the NOFA.

Catalog of Federal Domestic Assistance. The Catalog of Federal Domestic Assistance Number for this program is 14.219.

Accordingly, FR Doc. 97-32851, the NOFA for the HUD-Administered Small Cities Community Development Block Grant (CDBG) Program—Fiscal Year 1997 and Fiscal Year 1998; and the Section 108 Loan Guarantee Program for Small Communities in New York State, published in the *Federal Register* on December 16, 1997 (60 FR 65970) is amended as follows:

1. On page 65970, in column 2, the four paragraphs under the heading **DATES** are amended to read as follows:

DATES: Applications (including applications from recipients approved for a multiyear plan for second or third component in FY 1997 or FY 1998) are due by April 2, 1998. Application kits may be obtained from and must be submitted to either HUD's New York or Buffalo Office. (The addresses for these offices are provided in Section II. of this NOFA.)

Applications, if mailed, must be postmarked no later than midnight on April 2, 1998. If an application is hand-delivered to the New York or the Buffalo Office, the application must be delivered to the appropriate office by no later than 4:00 p.m. (local time) on April 2, 1998.

HUD expects to make application kits available in field offices by a date that affords applicants no fewer than 45 days to respond to this NOFA. If HUD fails to do so, a further extension of the application deadline will be published in the *Federal Register*. For further information on obtaining and submitting applications, please see Section II. of the NOFA.

The above-stated application deadline is firm as to date and hour. In the interest of fairness to all competing applicants, HUD will treat as *ineligible for consideration* any application that is not received by 4:00 p.m. on, or postmarked by, April 2, 1998. Applicants should take this procedure into account and make early submission of their materials to avoid any risk of loss of eligibility brought about by unanticipated delays or other delivery-related problems.

2. On page 65974, in column 1, section I.D.2.c., under the heading "*Special Limitations for Multiyear Plan Recipients*", is amended to read as follows:

I. Purpose and Substantive Description

* * * * *

D. Types of Grants

* * * * *

2. Single Purpose Grants

* * * * *

c. *Special Limitations for Multiyear Plan Recipients.* With respect to multiyear plan recipients that choose to submit applications for their second and/or third year increments, such applicants may also submit applications for up to two Single Purpose grants, provided that the sum of the grant amount requested for each approved multiyear increment plus the Single Purpose grant amount requested does not exceed \$400,000 (or \$600,000 in the case of a county applicant).

* * * * *

Dated: February 4, 1998.

Saul N. Ramirez, Jr.,

Assistant Secretary for Community Planning and Development.

[FR Doc. 98-3238 Filed 2-9-98; 8:45 am]

BILLING CODE 4210-29-P

DEPARTMENT OF HOUSING AND URBAN DEVELOPMENT

[Docket No. FR-4325-N-01]

Privacy Act of 1974; Proposed Amendment to a System of Records

AGENCY: Office of Administration, HUD.
ACTION: Notification of a proposed amendment to an existing system of records.

SUMMARY: In accordance with the Privacy Act of (5 U.S.C. 552a(e)(11)), HUD is issuing notice of our intent to amend the system of records entitled HUD/Dept-34, Pay and Leave Records of Employees, to include a new routine use. The disclosure is required by the Personal Responsibility and Work Opportunity Reconciliation Act. We invite public comment on this publication.

DATES: Effective date: The proposed routine use will become effective as proposed without further notice March 12, 1998, unless comments dictate otherwise.

Comments due by: Persons wishing to comment on the proposed routine use must do so by March 12, 1998.

ADDRESSES: Interested persons are invited to submit comments regarding this notice to the Rules Docket Clerk, Office of General Counsel, Room 10276, Department of Housing and Urban Development, 451 Seventh Street, SW, Washington, DC 20410. Communications should refer to the above docket number and title. A copy

of each communication submitted will be available for public inspection and copying between 7:30 a.m. and 5:30 p.m. weekdays at the above address.

FOR FURTHER INFORMATION CONTACT: Jeanette Smith, Privacy Act Officer, Telephone Number (202) 708-2374 [This is not a toll-free number] or FAX Number (202) 708-3577.

SUPPLEMENTARY INFORMATION: Pursuant to the Personal Responsibility and Work Opportunity Reconciliation Act of 1996. (Pub. L. 104-193, approved August 22, 1996), HUD will disclose data from its Privacy Act system of records, HUD/Dept-34, Pay and Leave Records of Employees, to the Office of Child Support Enforcement, Administration for Children and Families, Department of Health and Human Services for use in the National Database of New Hires, part of the Federal Parent Locator Service (FPLS) and Federal Tax Offset System, DHHS/OCSNE No. 09-90-0074. A description of the Federal Parent Locator Service may be found at 62 FR 51663 (October 2, 1997).

FPLS is a computerized network through which States may request location information from federal and State agencies to find non-custodial parents and their employers for purposes of establishing paternity and securing support. On October 1, 1997, the FPS was expanded to include the National Directory of New Hires, a database containing employment information on employees recently hired, quarterly wage data on private and public sector employees, and information on unemployment compensation benefits. On October 1, 1998, the FPLS will be expanded further to include a Federal Case Registry. The Federal Case Registry will contain abstracts on all participants involved in child support enforcement cases. When the Federal Case Registry is instituted, its files will be matched on an ongoing basis against the files in the National Directory of New Hires to determine if an employee is a participant in a child support case anywhere in the country. If the FPLS identifies a person as being a participant in a State child support case, that State will be notified. State requests to the FPLS for location information will also continue to be processed after October 1, 1998.

When individuals are hired by HUD, we may disclose to the FPLS their names, social security numbers, home addresses, dates of birth, dates of hire, and information identifying us as the employer. We also may disclose to FPLS names, social security numbers, and quarterly earnings of each HUD

employee, within one month of the end of the quarterly reporting period.

Information submitted by HUD to the FPLS will be disclosed by the Office of Child Support Enforcement to the Social Security Administration for verification to ensure that the social security number provided is correct. The data disclosed by HUD to the FPLS will also be disclosed by the Office of Child Support Enforcement to the Secretary of the Treasury for use in verifying claims for the advance payment of the earned income tax credit or to verify a claim of employment on a tax return.

Accordingly, HUD/Dept-34, Pay and Leave Records of Employees system notice originally published in the "Federal Register Privacy Act Issuances, 1995 compilation, is further amended by addition of the new routine use disclosure below.

A report of HUD's intention to add a new routine use disclosure has been submitted to the Office of Management and Budget (OMB), the Senate Committee on Governmental Affairs, and the House Committee on Government and Oversight pursuant to paragraph 4 of Appendix I to OMB Circular No. A-130, "Federal Agency Responsibilities for Maintaining Records About Individuals," February 8, 1996.

Authority: 5 U.S.C. 552a, 88 Stat. 1896; 42 U.S.C. 3535(d).

Dated: February 4, 1998.

David S. Cristy,

Acting Deputy Director, Office of Information Technology.

HUD/DEPT-34

SYSTEM NAME:

Pay and Leave Records of Employees.

* * * * *

ROUTINE USES OF RECORDS MAINTAINED IN THE SYSTEM, INCLUDING CATEGORIES OF USERS AND THE PURPOSES OF SUCH USES:

* * * * *

The names, social security numbers, home addresses, dates of birth, dates of hire, quarterly earnings, employer identifying information, and State of hire of employees may be disclosed to the Office of Child Support Enforcement, Administration for Children and Families, Department of Health and Human Services for the purpose of locating individuals to establish paternity, establishing and modifying orders of child support, identifying sources of income, and for other child support enforcement actions as required by the Personal

Responsibility and Work Opportunity Reconciliation Act, Pub. L. 104-193).

[FR Doc. 98-3237 Filed 2-9-98; 8:45 am]

BILLING CODE 4210-01-M

DEPARTMENT OF THE INTERIOR

Fish and Wildlife Service

Endangered and Threatened Species Permit Applications

AGENCY: Fish and Wildlife Service.

ACTION: Notice of receipt of permit applications.

SUMMARY: The following applicants have applied for a scientific research permit to conduct certain activities with endangered species pursuant to section 10 (a)(1)(A) of the Endangered Species Act of 1973, as amended (16 U.S.C. 1531 et seq.).

Permit No.'s: 741345, 756268, 777965, 816204, 831207, 787392, 745541, 804203, 744707, 802453, 787644, 809230, 775869

Applicants: Baxter Consulting Services, Lake Mathews, California; Philip Behrends, Solana Beach, California; LSA, Irvine, California; Douglas Kelt, Davis, California; Kirtland Biological Services, Riverside, California; San Bernardino County Museum, Redlands, California; SJM Biological Consultants, San Diego, California; Stephen Myers, Riverside, California; Michael O'Farrel, Las Vegas, Nevada; Mary Price, Riverside, California; William Vanherweg, Bakersfield, California; Leroy McClenaghan, San Diego, California; Richard Friesen, Irvine, California.

These applicants request a permit amendment to take (capture, handle, and release) the San Bernardino kangaroo rat (*Dipodomys merriami parvus*) in conjunction with presence or absence surveys, population monitoring, and research in Riverside and San Bernardino Counties, California, for the purpose of enhancing its survival.

Permit No.'s: 780195, 786497, 802447, 781220, 783926

Applicants: Royce B. Riggan, Jr., San Diego, California; Paul Principe, Murrieta, California; Kimberly Miller, San Diego, California; William D. Wagner, Wrightwood, California; California Department of Transportation, San Diego, California.

These applicants request a permit amendment to take (harass by survey) the Quino checkerspot butterfly (*Euphydryas editha quino*) in conjunction with presence or absence surveys and ecological research throughout the species' range in California, for the purpose of enhancing its survival.

Permit No.'s: 838741, 839084, 839078

Applicant: Larry D. Munsey, Tustin, California; Wendy Loeffler, Orange, California; Spencer Langdon, Costa Mesa, California.

These applicants request a permit to take (harass by survey) the Quino checkerspot butterfly (*Euphydryas editha quino*) in conjunction with presence or absence surveys and ecological research throughout the species' range in California, for the purpose of enhancing its survival.

Permit No.: 838739

Applicant: Larry Munsey International, Irvine, California.

The applicant requests a permit to take (harass by survey) the Quino checkerspot butterfly (*Euphydryas editha quino*) in conjunction with presence or absence surveys and ecological research throughout the species' range in California, for the purpose of enhancing its survival.

Permit No.: 702631

Applicant: Assistant Regional Director-Ecological Services, Region 1, Fish and Wildlife Service, Portland, Oregon.

The applicant requests a permit amendment to take (capture, handle, and release) the San Bernardino kangaroo rat (*Dipodomys merriami parvus*) throughout the species' range in California in conjunction with recovery efforts, for the purpose of enhancing its survival.

DATES: Written comments on these permit applications must be received on or before March 12, 1998.

ADDRESSES: Written data or comments should be submitted to the Chief, Division of Consultation and Conservation Planning, Ecological Services, Fish and Wildlife Service, 911 N.E. 11th Avenue, Portland, Oregon 97232-4181; FAX: (503) 231-6243. Please refer to the respective permit number for each application when submitting comments. All comments, including names and addresses, received will become part of the official administrative record and may be made available to the public.

FOR FURTHER INFORMATION CONTACT: Documents and other information submitted with these applications are available for review, subject to the requirements of the Privacy Act and the Freedom of Information Act, by any party who submits a written request for a copy of such documents within 20 days of the date of publication of this notice to the address above; telephone: (503) 231-2063. Please refer to the respective permit number for each

application when requesting copies of documents.

Dated: February 4, 1998.

Don Weathers,

Acting Regional Director, Region 1, Portland, Oregon.

[FR Doc. 98-3255 Filed 2-9-98; 8:45 am]

BILLING CODE 4310-55-P

DEPARTMENT OF THE INTERIOR

Fish and Wildlife Service

Notice of Availability of a Draft Recovery Plan for the Star Cactus (*Astrophytum asterias*) for Review and Comment

AGENCY: Fish and Wildlife Service, Interior.

ACTION: Notice of document availability.

SUMMARY: The U.S. Fish and Wildlife Service announces the availability for public review of a draft recovery plan for the star cactus (*Astrophytum asterias*). This species occurs in the grasslands and thornshrub of the Rio Grande Plains of Texas and Tamaulipas, Mexico. It is found on gravelly clays or loams overlaying the Tertiary Catahoula and Frio formations in the United States, and on soils of limestone origin overlaying Cenozoic to Mesozoic marine sediments in Tamaulipas. The historical range of star cactus included Cameron, Hidalgo, and Starr Counties in South Texas and the states of Nuevo Leon and Tamaulipas in Mexico. The cactus was historically and is still found on private lands and may also occur on State lands or highway right-of-ways. The Service solicits review and comment from the public on this draft plan.

DATES: Comments on the draft recovery plan must be received on or before May 11, 1998, to receive consideration by the Service.

ADDRESSES: Persons wishing to review the draft recovery plan may examine a copy by contacting Field Supervisor, U.S. Fish and Wildlife Service, Ecological Services Field Office, c/o TAMU-CC Campus Box 338, 6300 Ocean Drive, Corpus Christi, Texas, 78412. Telephone (512) 994-9005. Fax No. (512) 994-8262. Written comments and materials regarding the plan should also be addressed to the above address. Comments and materials received will be made available upon request for public inspection by appointment during normal business hours at the same address.

FOR FURTHER INFORMATION CONTACT: Field Supervisor, U.S. Fish and Wildlife Service (Corpus Christi) at (512) 994-9005.

SUPPLEMENTARY INFORMATION:

Background

Restoring an endangered or threatened animal or plant to the point where it is a secure, self-sustaining member of its ecosystem, is a primary goal of the U.S. Fish and Wildlife Service's endangered species program. To help guide the recovery effort, the Service prepares recovery plans for most of the listed species native to the United States. Recovery plans describe actions considered necessary for conservation of the species, establish criteria for the recovery levels for reclassifying them from endangered to threatened status or removing them from the list, and estimate the time and cost for implementing the needed recovery measures.

The Endangered Species Act of 1973 (Act), as amended (16 U.S.C. 1531 *et seq.*) requires the development of recovery plans for listed species unless such a plan would not promote the conservation of a particular species. Section 4(f) of the Act, as amended in 1988, requires that public notice and opportunity for public review and comment be provided during recovery plan development. The Service will consider all information presented during a public comment period prior to approval of each new or revised Recovery Plan. The Service and other Federal agencies will take these comments into account in the course of implementing approved recovery plans.

The star cactus was listed as an endangered species on November 17, 1993. The primary objective of this recovery plan is to maintain sufficient star cactus populations in natural habitats to ensure that the species is safe from extinction. This species is threatened by habitat destruction and modification through conversion of native habitat to agricultural land uses and urban development; collection of wild plants for the cactus trade; competition with exotic grasses introduced for cattle forage and erosion control; and genetic vulnerability due to low population numbers. The Recovery Plan is the product of considerable biological and historical data developed by a team of scientists, agency personnel, stakeholders from the management community, conservation organizations, and the general public. It provides scientific information about the species and establishes management plans for the protection of native populations, and the development of new populations to enhance its range and abundance to the extent that no natural or man-caused disturbance will result in irrevocable losses.

Public Comments Solicited

The Service solicits written comments on the recovery plan described. All comments received by the date specified above will be considered prior to approval of the plan.

Authority

The Authority for this action is section 4(f) of the Endangered Species Act, 16 U.S.C. 1533(f).

Dated: January 30, 1998.

Ren Loehfner,

Acting Regional Director, Fish and Wildlife Service, Region 2.

[FR Doc. 98-3232 Filed 2-9-98; 8:45 am]

BILLING CODE 4310-55-F

DEPARTMENT OF THE INTERIOR

Fish and Wildlife Service

Application for Approval of Tin Shot as Nontoxic for Waterfowl Hunting

AGENCY: Fish and Wildlife Service, Interior.

ACTION: Notice of application.

SUMMARY: The U.S. Fish and Wildlife Service (Service) announces that the International Tin Research Institute, Ltd. (ITRI), of Uxbridge, Middlesex, United Kingdom, has applied for approval of tin shot as nontoxic for waterfowl hunting in the United States. The Service has initiated review of the Tier 1 application.

FOR FURTHER INFORMATION CONTACT: Paul R. Schmidt, Chief, or Carol Anderson, Wildlife Biologist, Office of Migratory Bird Management (MBMO), (703) 358-1714.

SUPPLEMENTARY INFORMATION: Since the mid-1970s, the Service has sought to identify shot that, when spent, does not pose a significant toxic hazard to migratory birds and other wildlife. Currently, only bismuth-tin and steel shot are approved by the Service as nontoxic. Tungsten-iron shot received temporary conditional approval for the 1997-98 hunting season. The Service believes approval for other suitable candidate shot materials as nontoxic is feasible.

On November 5, 1997, ITRI submitted their Tier 1 application for approval of pure tin shot as nontoxic pursuant to 50 CFR 20.134 (recently amended—see 62 FR 63608, December 1, 1997). The Service has determined that the application is complete, and has initiated a comprehensive review of the Tier 1 information to be concluded within April 13, 1998. After this review, the Service will either 1) publish a *Notice of Review* to inform the public

that the Tier 1 test results are inconclusive or 2) publish a proposed rule for approval of the candidate shot. The *Notice of Review* will indicate whether Tier 2, Tier 3, or both tests will be required before nontoxic approval of the tin shot is granted. If the Tier 1 data results in a preliminary determination that the candidate material does not impose a significant danger to migratory birds, other wildlife, and their habitats, the Service will propose to approve this shot based on the toxicological report and toxicity studies.

ITRI's candidate shot is made from commercially pure tin; no alloying or other alterations are intentionally made to the chemical composition of the shot. This shot has a density of approximately 7.29 g/cm³. The shot is 99.97 percent tin, with a low level of iron pickup due to the steel production equipment.

The application includes a statement of proposed use, a description of the new shot, a statement of expected variability of shot during production, an estimate of yearly production, and a 5-pound sample of shot. It also includes a discussion on the toxicity of elemental tin to wildlife and man and the fate of discharged tin shot in the environment (Tier 1). ITRI's discussion incorporates the following toxicity information: a synopsis of toxicity data for wild mammals (including man) and birds; secondary toxicosis of avian predators; potential dissolution and absorption of ingested tin shot; effect of one shot absorbed in 24 hours; toxicity to fish, amphibians, and reptiles; effects of firing tin shot; chemical transformation of tin shot in the environment; and information on environmental fate and transport.

References available upon request.

Authorship

The primary author of this notice of application is Carol Anderson, Wildlife Biologist, Office of Migratory Bird Management.

Dated: January 30, 1998.

Jamie Rappaport Clark,

Director, U.S. Fish and Wildlife Service.

[FR Doc. 98-3253 Filed 2-9-97; 8:45 am]

BILLING CODE 4310-55-F

DEPARTMENT OF THE INTERIOR

Geological Survey

Technology Transfer Act of 1986

AGENCY: U.S. Geological Survey, Interior.

ACTION: Notice to accept contribution from private source.

SUMMARY: The U.S. Geological Survey is accepting a \$50,000 contribution per year for 2 years from Exxon Exploration Company to support the World Energy Project.

ADDRESSES: If any other parties are interested in making contributions for the same or similar purposes, please contact Dr. Thomas Ahlbrandt, U.S. Geological Survey, Central Region Energy Resources Team, Box 25046, Mail Stop 939, Denver, Colorado 802325-0046; telephone (303) 246-5776; e-mail ahlbrandt@usgs.gov.

SUPPLEMENTARY INFORMATION: This notice is to meet the USGS requirement stipulated in the Survey Manual.

Dated: January 26, 1998.

P. Patrick Leahy,

Chief, Geologic Division.

[FR Doc. 98-3339 Filed 2-9-98; 8:45 am]

BILLING CODE 4310-31-M

DEPARTMENT OF THE INTERIOR

Bureau of Land Management

DEPARTMENT OF AGRICULTURE

Forest Service

[CO-030-5101-00-YCKD; COC-51280]

Availability of the Draft Supplement to the Final Environmental Impact Statement for a TransColorado Gas Transmission Project; Colorado and New Mexico

AGENCY: Bureau of Land Management, Department of the Interior, and Forest Service, Department of Agriculture.

ACTION: Amendment to Notice of Availability of a Supplement to The Final Environmental Impact Statement TransColorado Gas Transmission Project; Colorado and New Mexico; Correction for Written Comments Due Date.

SUMMARY: In accordance with the National Environmental Policy Act, the Bureau of Land Management (BLM), as lead agency, and in cooperation with the U.S. Forest Service (USFS) has prepared a Draft Supplement (Supplement) to the Final Environmental Impact Statement (FEIS) for the TransColorado Gas Transmission (TransColorado) project on federal lands in Colorado and New Mexico.

An amendment to the Notice of Availability for the Draft Supplement was published on February 2, 1998 (Volume 63, Number 21, Page 5400-5401) in the Federal Register. In that

amendment, the date on which written comments on the Draft Supplement must be postmarked or submitted was incorrectly shown as being March 10, 1998. This Notice amends the date on which written comments on the Draft Supplement must be postmarked or submitted. The correct date on which written comments on the Draft Supplement must be submitted or postmarked is no later than March 18, 1998, to coincide with the date the public comment period on the Draft Supplement ends. This Notice also includes the date and starting time of the public meeting on the Draft Supplement to be held in Grand Junction, Colorado. The Amendment published in the Federal Register on February 2, 1998 for the Draft Supplement omitted the date of the Grand Junction meeting. The Grand Junction meeting will be held on February 19, 1998, at 7:00 pm at the Holiday Inn, 755 Horizon Drive in Grand Junction, Colorado. Written comments on the Draft Supplement may be submitted at the Grand Junction meeting and two other public meetings to be held on February 17, 1998 at 7:00 pm at the Double Tree Inn, 501 Camino del Rio in Durango, Colorado, and on February 18, 1998 at 7:00 pm at the Ponderosa Restaurant, 108 South 8th in Dolores, Colorado.

FOR FURTHER INFORMATION CONTACT: Bill Bottomly (970) 240-5337, Ilyse Auringer (970) 385-1341, or Steve Hemphill (970) 874-6633.

Signed: February 4, 1998.

Phillip Dwyer,

Assistant District Manager for Support Services, Montrose District, BLM.

Robert L. Storch,

Forest Supervisor, Grand Mesa/Uncompahgre/Gunnison National Forests.

[FR Doc. 98-3257 Filed 2-9-98; 8:45 am]

BILLING CODE 4310-JB-P

DEPARTMENT OF THE INTERIOR

Bureau of Land Management

[NV 910 0777 30]

Northeastern Great Basin Resource Advisory Council Meeting Location and Time

AGENCY: Bureau of Land Management, Interior.

ACTION: Resource Advisory Council's Meeting Location and Time.

SUMMARY: In accordance with the Federal Land Policy and Management Act and the Federal Advisory Committee Act of 1972 (FACA), 5

U.S.C., the Department of the Interior, Bureau of Land Management (BLM), Council meetings will be held as indicated below. The agenda for this meeting includes: approval of minutes of the previous meetings, Standards and Guidelines, wild horses, Interior Columbia River Basin Draft Environmental Impact Statement, Bureau of Land Management water rights and policy in Nevada, road standards, off highway vehicles, identification of additional issues to be resolved and determination of the subject matter for future meetings.

All meetings are open to the public. The public may present written comments to the Council. Each formal Council meeting will also have time allocated for hearing public comments. The public comment period for the Council meeting is listed below. Depending on the number of persons wishing to comment and time available, the time for individual oral comments may be limited. Individuals who plan to attend and need special assistance, such as sign language interpretation, tour transportation or other reasonable accommodations, should contact the District Manager at the Battle Mountain District Office, 50 Bastion Road, Battle Mountain, Nevada, 89820, telephone (702) 635-4000.

DATES, TIMES, PLACE: The time and location of the meeting is as follows: Northeastern Great Basin Resource Advisory Council, Battle Mountain District Office, 50 Bastion Road, Battle Mountain, Nevada, 89820; March 9, 1998 starting at 9:00 a.m.; public comments will be at 11:00 a.m. and 3:00 p.m.; tentative adjournment for the day at 5:00 p.m.

FOR FURTHER INFORMATION CONTACT:

Curtis G. Tucker, Team Leader for the Northeastern Resource Advisory Council, Ely District Office, 702 North Industrial Way, HC 33 Box 33500, Ely, NV 89301-9408, telephone 702-289-1841.

SUPPLEMENTARY INFORMATION: The purpose of the Council is to advise the Secretary of the Interior, through the BLM, on a variety of planning and management issues, associated with the management of the public lands.

Dated: February 3, 1998.

Gerald M. Smith,

District Manager, Battle Mountain.

[FR Doc. 98-3256 Filed 2-9-98; 8:45 am]

BILLING CODE 4310-MC-M

DEPARTMENT OF THE INTERIOR

Bureau of Land Management

[AZ-030-1050-00; AZA-25624]

Notice of Realty Action, Recreation and Public Purpose (R&PP) Act Classification, Arizona

AGENCY: Bureau of Land Management, Interior.

ACTION: Notice.

SUMMARY: The Golden Valley, Fire Department, Station #2, 749 S. Egar Road, Golden Valley, Arizona, has filed an R&PP application amending their original lease of 2½ acres for a fire station to add an additional 2½ acres for a training facility located on the following public lands.

Gila and Salt River Base and Meridian, Mohave County, Arizona

Township 21 North, Range 19 West
Sec 16, SE¼SE¼SE¼NE¼

Comprising 2½ acres, more or less

Lease or conveyance is consistent with current BLM land use planning and would be in the public interest.

The lease/patent, when issued, will be subject to the following terms, conditions, and reservation:

1. Provisions of the Recreation and Public Purpose Act and to all applicable regulations of the Secretary of the Interior.

2. A right-of-way for ditches and canals constructed by the authority of the United States.

3. All minerals shall be reserved to the United States, together with the right to prospect for mine, and remove the minerals.

Detailed information concerning this action is available for review at the office of the Bureau of Land Management, Kingman Field Office, 2475 Beverly Avenue, Kingman, Arizona.

Upon publication of this notice in the *Federal Register*, the lands will be segregated from all other forms of appropriation under the public land laws, including the general mining laws, except for lease or conveyance under the Recreation and Public Purpose Act and leasing under the mineral leasing laws.

For a period of 45 days from the date of publication of this notice, interested persons may submit comments regarding the amended proposed lease/conveyance or classification of the land to Joyce Bailey, Realty Specialist, Kingman Field Office, 2475 Beverly Ave, Kingman, Arizona, 86401, telephone (520) 692-4400. Any adverse comments will be reviewed by the State

Director. In the absence of any adverse comments, the classification will become effective 60 days from the date of publication of this notice.

John R. Christensen,

Field Manager.

[FR Doc. 98-3340 Filed 2-9-98; 8:45 am]

BILLING CODE 4310-32-M

DEPARTMENT OF THE INTERIOR

Bureau of Reclamation

Notice of Intent To Prepare a Programmatic Environmental Impact Statement for a Recovery Implementation Program for Four Threatened and Endangered Species in the Central Platte River Region and Announcement of Public Scoping Meetings

AGENCY: Bureau of Reclamation, Interior.

ACTION: Notice of intent to prepare a programmatic environmental impact statement, and announcement of public scoping meetings.

SUMMARY: The U.S. Department of the Interior, Bureau of Reclamation (Reclamation) and Fish and Wildlife Service (Service), announce their intent to prepare a Programmatic Environmental Impact Statement (PEIS) pursuant to the National Environmental Policy Act (NEPA) of 1969, as amended.

This PEIS will evaluate impacts of alternative Recovery Implementation Programs (Programs) to: (1) Secure defined benefits for the target species and their associated habitats to assist in their conservation and recovery through a basin-wide cooperative approach that can be agreed to by the three states and the Department of the Interior (Department); (2) serve as the reasonable and prudent alternative to offset the effects of existing and new water related activities in the Platte River Basin that, in the absence of such a Program, would be found by FWS to be likely to jeopardize the continued existence of the target species or adversely modify designated critical habitat; (3) help prevent the need to list more basin associated species pursuant to the ESA; and (4) mitigate new water related activities in a state in a manner that will not increase the mitigation responsibilities of other signatory states.

The Department invites other Federal agencies, States, Indian tribes, local governments, and the general public to submit written comments or suggestions concerning the scope of the issues to be addressed, alternatives to be analyzed, and the environmental impacts to be

assessed in the Draft PEIS. The public is invited to participate in a series of scoping workshops and meetings that will be held during the months of February through April in Wyoming, Nebraska, and Colorado. A schedule of the meetings is provided. Those not desiring to submit comments or suggestions at this time, but who would like to receive a copy of the Draft PEIS, should write to the address below.

During the scoping process, Reclamation and the Service will be identifying which other Federal, State and local agencies, and tribal governments may have expertise or authority relative to the Program and may be invited to become cooperating agencies in the preparation of the PEIS.

When the Draft PEIS is complete, its availability will be announced in the *Federal Register* and in the local news media. Comments will be solicited on this document.

DATES: See SUPPLEMENTARY INFORMATION section for meeting dates.

ADDRESSES: See SUPPLEMENTARY INFORMATION section for meeting locations.

FOR FURTHER INFORMATION CONTACT: Dr. Curt Brown, Study Manager, or Ms. Lynn Holt, Outreach Coordinator, Platte River EIS Office, PO Box 25007, Mail Code PL-100, Department of the Interior, Denver, Colorado 80225-0007. Telephone: (303) 445-2096. FAX: (303) 445-6331.

SUPPLEMENTARY INFORMATION:

Background

The States of Nebraska, Wyoming, and Colorado, and the U.S. Department of the Interior have entered into an agreement to begin cooperatively addressing endangered species issues in the Platte River in Nebraska which may affect the entire Platte River Basin, including development of a recovery implementation program (Program). (*Cooperative Agreement for Platte River Research and Other Efforts Relating to Endangered Species Habitat Along the Central Platte River, Nebraska*. Signed July 1, 1997, by the Governors of Wyoming, Colorado, and Nebraska, and the Secretary of the U.S. Department of the Interior.) A copy of the Cooperative Agreement may be obtained by contacting the Platte River EIS Office, or attending a scoping meeting. It is also available at the Platte River EIS website: <http://www.usbr.gov/platte>.

Purpose and Need for Action

The whooping crane, piping plover, and interior least tern, which are listed as threatened or endangered under the Endangered Species Act (ESA), use the

Central Platte River Valley in Nebraska. The Fish and Wildlife Service has designated the reach of the Central Platte River from Lexington to Shelton, Nebraska, as critical habitat for the whooping crane. The pallid sturgeon, which occurs in the Lower Platte River between its confluence with the Elkhorn and the Missouri River, is also listed as endangered. Together, these four species are the "target species" for the partnership.

The waters of the Platte River serve the people of Wyoming, Colorado and Nebraska in many ways. Federal and non-Federal water projects in the Platte River Basin, including 15 major dams, provide municipal and industrial water supplies for about 3.5 million people, irrigate millions of acres of farmland, and generate millions of dollars in hydroelectric power. These projects also provide flood control, recreation, and fish and wildlife habitat.

The Service has concluded that suitable habitat in the Central Platte region for the target species has been significantly reduced by water diversions and other factors, such as highway and bridge construction and other changes in land use that have come with extensive settlement throughout the Platte River Basin. Under the ESA, Federal agencies must ensure that the water projects which they operate or for which they provide Federal permits or funds are not likely to jeopardize the continued existence of any threatened or endangered species or to adversely modify critical habitat. If a project is likely to cause these adverse impacts, its operation must be modified or other measures undertaken to protect the species.

Many water projects in the Platte River Basin are now or soon will be undergoing a review of their impacts on endangered species. These projects include Reclamation's North Platte Projects in Wyoming and western Nebraska and the Colorado Big Thompson Project in Colorado; the Corps of Engineers' reservoirs in the Denver area; and a large number of non-Federal water storage and diversion projects, primarily in Colorado, which require renewal of permits from the U.S. Forest Service. Also included are the non-Federal hydropower projects in Nebraska and Colorado, including Kinglsey Dam, which require license renewals from the Federal Energy Regulatory Commission (FERC).

The Department believes that the best approach to addressing the ESA issues in the Platte region in Nebraska is a basin-wide, cooperative effort to improve and maintain habitat for the target species. The alternative to a basin-

wide approach would be for each of these water projects in the Platte River Basin to undergo individual review and lengthy proceedings to develop separate measures to help the listed species. The Department believes that a basin-wide, cooperative approach will be more effective, efficient, and equitable, and provide greater certainty for water users regarding compliance with the ESA.

The purpose of the Proposed Program, and any Program alternatives formulated is to:

1. Secure defined benefits for the target species and their associated Platte River habitat through a Program that offsets the effects of existing and new water related activities in the basin that without a Program would be found likely to jeopardize the continued existence of the target species or adversely modify critical habitat. ("Associated habitats," "water related activities," and "new water related activities" are defined in the Cooperative Agreement.) This will be accomplished by implementing certain aspects of the Fish and Wildlife Service recovery plans for the target species that relate to their associated habitats by:

- Improving and maintaining the migrational habitat for the whooping cranes.
- Improving and maintaining the reproductive habitat for the interior least tern and the piping plover.
- Testing the assumption that it is possible to improve habitat for the pallid sturgeon by managing flows in the Central Platte River that may also affect the sturgeon's habitat in the Lower Platte River.

2. Ensure that the effects of future water activities in the Platte River Basin are offset so that they are not likely to jeopardize the continued existence of the target species or adversely modify critical habitat. Mitigate new water related activities in the States of Wyoming, Colorado, and Nebraska in a manner that will not increase the mitigation responsibilities of the other states.

3. Provide greater regulatory certainty regarding compliance with section 7 of the ESA, by serving as the reasonable and prudent alternative under the ESA for existing and new water related activities.

4. Help prevent the need to list more species associated with the Platte River as threatened or endangered pursuant to the ESA.

5. Accomplish these goals through a cooperative, basin-wide approach that can be agreed to by the three States and the Department of the Interior.

The Proposed Federal Action

The Cooperative Agreement describes a proposed Recovery Implementation Program to address the endangered species issues. This proposed Program, and alternatives, will be evaluated according to the requirements of the National Environmental Policy Act.

The long-term objectives for the proposed Program are to:

- Provide additional or modified river flows to and through the Central Platte habitat area. The Service has identified flow levels they believe are necessary to provide adequate habitat for the endangered species. Existing flows currently fall short of these targets. The Department and the States agree that flow targets will be reviewed and may be modified as new information becomes available.

- Improve habitat through management, leasing, or acquisition of approximately 29,000 acres of suitable habitat between Lexington and Chapman, Nebraska.

- Mitigate or offset any impacts on the target species that might result from new water related activities in the basin.

The first phase of the proposed Program (10-12 years) would:

- Reduce shortages to the current target flows by an average of 130,000 to 150,000 acre-feet per year. The proposed Program would restore the original storage capacity of Pathfinder Reservoir in Wyoming; establish an environmental water account in Lake McConaughy in Nebraska; and develop a groundwater recharge and river re-regulation project near Tamarack State Wildlife Area in Colorado. These three actions are expected to reduce shortages by approximately 70,000 acre-feet of water. A basin-wide study will look for ways to provide an additional 60,000 acre-foot reduction in flow shortages through water conservation and water supply options.

- Protect or restore, through acquisition, lease, or easement, 10,000 acres of habitat in the Central Platte River area between Lexington and Chapman, Nebraska. The Nebraska Public Power District's Cottonwood Ranch between Overton and Elm Creek (2,650 acres) will contribute to that goal.¹

All water conservation, habitat management, leases, easements, or acquisition of lands to meet these goals

¹ In later phases of the proposed Program, the holdings of the Platte River Whooping Crane Maintenance Trust, the Nebraska Game and Parks Commission, the Nature Conservancy, and the Audubon Society, totaling approximately 9,000 acres of habitat, will be included toward the long-term goal of 29,000 acres.

would be undertaken only with willing sellers and participants.

Progress made under this initial phase of the proposed Program would be closely monitored. The cooperating entities would then evaluate the results of the first phase and define any subsequent approaches and actions needed to meet the overall goals.

Additional description of the proposed Program can be obtained by contacting the Platte River EIS Office at the address above.

Programmatic EIS

The impacts of the proposed Program and alternatives will be evaluated through a PEIS. This assessment will look at the effects of the proposed Program and alternatives primarily upon the habitat of the four target threatened and endangered species along the Central Platte River in Nebraska in order to assess the degree to which each alternative achieves the program purposes. Other impacts of the alternatives will be examined more broadly. Once a preferred alternative is selected for implementation, further NEPA compliance may be required for site-specific Federal actions. For example, the PEIS will examine the effects of restoring the original storage in Pathfinder Reservoir upon the water operations of Reclamation's North Platte reservoirs and the downstream effects upon the habitat of the target species. If this element is part of the ultimately selected Program, an additional site-specific NEPA study would likely need to be undertaken to assess, for example, the construction impacts of raising Pathfinder Dam. Similarly, it is expected that the PEIS will examine the benefits to the habitat of the target species from a range of water conservation measures throughout the Platte River Basin, including the costs of such measures and their broad effects on factors such as water use, associated revenues, and local taxes. It is possible that further NEPA compliance might be required prior to implementing some specific conservation measures in specific locations.

A Draft PEIS is scheduled for completion by mid-1999.

Public Scoping

Scoping meetings will be held in Wyoming, Colorado, and Nebraska in February through April of 1998 for the purpose of obtaining public input and suggestions on the significant issues related to the proposed action. The schedule and locations for these activities are shown below. The public is especially asked to provide input on:

(1) alternative approaches to meeting the needs and purposes of the Federal action. For example, are there more effective or feasible ways to improve or protect the habitat of the four target species? Suggestions could address individual elements of a plan, such as ways to conserve water or to improve habitat management, or could provide broader options, such as reoperation of the Federal reservoirs in the Platte River Basin. Suggestions also could address such factors as the timing of a program, e.g., implementing an entire program at the onset, rather than using the phased, adaptive management approach in the proposed Program.

(2) impacts of the proposed Program and alternatives that should be evaluated and reported. In addition to the effects of the alternatives on the habitat of the target species, what are likely to be significant consequences of the various options that should be considered and reported?

Schedule of Scoping Meetings

A series of meetings will be conducted in Colorado, Nebraska, and Wyoming. Each will begin with a 1-hour open house at which the public can informally discuss issues and ask questions of staff and managers involved in the Platte River Endangered Species Partnership.

The open house will be followed by a more formal scoping meeting in which each participant will be given time to make comments. Speakers should plan on 5 minutes for their comments. These comments will be formally recorded. Speakers are encouraged to provide written versions of their oral comments, and any other additional written materials, for the record.

Comments may also be sent directly to the Platte River EIS Office to be included in the record.

Dates of Scoping Meetings

February 25, 1998, 5–8 p.m., Loveland, CO
 March 2, 1998, 4–7 p.m., Scottsbluff, NE
 March 3, 1998, 2–5 p.m., North Platte, NE
 March 4, 1998, 4–7 p.m., Grand Island, NE
 March 5, 1998, 4–7 p.m., Lincoln, NE
 March 11, 1998, 3–6 p.m., Kearney, NE
 March 17, 1998, 3–6 p.m., Saratoga, WY
 March 18, 1998, 4–7 p.m., Casper, WY
 March 19, 1998, 2–5 p.m., Torrington, WY
 March 26, 1998, 4–7 p.m., Sterling, CO
 April 7, 1998, 6–9 p.m., Denver, CO

Addresses of Scoping Meetings

• Loveland—Loveland Museum, 503 North Lincoln Avenue, Loveland, CO 80537.

- Scottsbluff—Scottsbluff Inn, 1901 21st Avenue, Scottsbluff, NE 69361.
- North Platte—Camino Inn & Suites, Jct US 83 & I-80, North Platte, NE 69101.
- Grand Island—Holiday Inn Midtown, 2503 South Locust, Grand Island, NE 68801.
- Lincoln—The Nebraska Center for Continuing Education, 33rd and Holdrege Street, Lincoln, NE 68583.
- Kearney—Regency Inn, 301 2nd Avenue, Kearney, NE 68847.
- Saratoga—Riviera Lodge, 104 East Saratoga Street, Saratoga, WY 82331.
- Casper—Casper Hilton Inn, 800 North Poplar Street, Casper, WY 82601.
- Torrington—The King's Inn, 1555 S Main Street, Torrington, WY 82240.
- Sterling—Ramada Inn, I-76 & Highway 6, Sterling, CO 80751.
- Denver—Stapleton Plaza Hotel and Fitness Center, (Ballroom Arapaho A), 3333 Quebec Street, Denver, CO 80207.

Dated: February 5, 1998.

Patricia J. Beneke,

Assistant Secretary—Water and Science,
 Department of the Interior.

[FR Doc. 98-3399 Filed 2-9-98; 8:45 am]

BILLING CODE 4310-84-P

INTERNATIONAL TRADE COMMISSION

Sunshine Act Meeting

AGENCY HOLDING THE MEETING: United States International Trade Commission.

TIME AND DATE: February 19, 1998 at 2:30 p.m.

PLACE: Room 101, 500 E Street S.W., Washington, DC 20436.

STATUS: Open to the public.

MATTERS TO BE CONSIDERED:

1. Agenda for future meeting: none
2. Minutes
3. Ratification List
4. Inv. Nos. 731-TA-776-779 (Preliminary) (Certain Preserved Mushrooms from Chile, China, India, and Indonesia)—briefing and vote.
5. Outstanding action jackets:
 1. Document No. GC-98-001: Decision whether to grant the appeals of Order No. 96 in Inv. No. 337-TA-383 (Certain Hardware Logic Emulation Systems and Components Thereof).

In accordance with Commission policy, subject matter listed above, not disposed of at the scheduled meeting, may be carried over to the agenda of the following meeting.

By order of the Commission:

Issued: February 5, 1998.

Donna R. Koehnke,
Secretary.

[FR Doc. 98-3424 Filed 2-6-98; 11:21 am]

BILLING CODE 7020-02-P

DEPARTMENT OF JUSTICE

Drug Enforcement Administration

[Docket No. 96-26]

Richard S. Wagner, M.D.; Revocation of Registration; Denial of Request to Modify Registration

On February 8, 1996, the Deputy Assistant Administrator, Office of Diversion Control, Drug Enforcement Administration, (DEA), issued an Order to Show Cause to Richard S. Wagner, M.D., (Respondent) of Fresno, California and Hanover, Pennsylvania, notifying him of an opportunity to show cause as to why DEA should not revoke his DEA Certificate of Registration, AW8019033, under 21 U.S.C. 824(a), and deny any pending applications for modification of his registration to change his address from California to Pennsylvania, under 21 U.S.C. 823(f). The Order to Show Cause alleged that Respondent materially falsified two applications for the renewal of his DEA Certificate of Registration and that he was not currently authorized to handle controlled substances in the Commonwealth of Pennsylvania.

Respondent, proceeding pro se, filed a request for a hearing, and following prehearing procedures, a hearing was held in Arlington, Virginia on August 27, 1996, before Administrative Law Judge Mary Ellen Bittner. At the hearing, both parties called witnesses to testify and introduced documentary evidence. Ultimately, the alleged lack of authorization to handle controlled substances in the Commonwealth of Pennsylvania was not pursued as an independent basis for revocation. After the hearing, counsel for the Government submitted proposed findings of fact, conclusions of law and argument. However, Respondent only filed a motion to expedite the matter, which was denied by Judge Bittner because Respondent did not provide any compelling reason to decide this matter before other pending cases. On October 20, 1997, Judge Bittner issued her Opinion and Recommended Ruling, Findings of Fact, Conclusions of Law and Decision, recommending that Respondent's DEA Certificate of Registration be revoked, his request for modification be denied, and any

pending applications for registration be denied.

On November 26, 1997, Respondent filed a response to Judge Bittner's decision, which reiterated the arguments Respondent raised at the hearing and also sought to introduce evidence not presented at the hearing. On November 28, 1997, Government counsel filed a motion to strike Respondent's exceptions or, in the alternative, to seek leave to file a response to Respondent's exceptions. The Government argued that Respondent's exceptions were not timely filed. Judge Bittner denied the Government's motion to strike Respondent's exceptions, finding that they were filed within the time period that she had authorized for the filing of exceptions, however, Judge Bittner provided the Government the opportunity to file a response to Respondent's exceptions. On December 17, 1997, the Government filed its response and also a motion to strike Respondent's additional exhibits arguing that the record is closed and Respondent could have introduced the exhibits at the hearing, but did not do so. Thereafter, on December 18, 1998, Judge Bittner denied the Government's motion to strike the additional exhibits, finding the "[p]ursuant to 21 C.F.R. § 1316.66(b) (1997), exceptions filed pursuant to 21 C.F.R. § 1316.66(a) are to become part of the record of the proceeding." However, Judge Bittner recommended that "the Deputy Administrator not consider these documents in rendering his final order." On December 18, 1997, Judge Bittner transmitted the record of these proceedings to the Acting Deputy Administrator.

The Acting Deputy Administrator, pursuant to 21 C.F.R. 1316.67, hereby issued his final order based upon findings of fact and conclusions of law as hereinafter set forth. In rendering his decision in this matter, the Acting Deputy Administrator has not considered Respondent's exceptions, including the attached additional documents, to the extent that they seek to introduce evidence not submitted at the hearing in this matter, since Respondent did not offer any explanation as to why this information was not presented at the hearing. After careful consideration of the record, the Acting Deputy Administrator adopts, in full, the Opinion and Recommended Ruling, Findings of Fact, Conclusions of Law and Decision of the Administrative Law Judge, and his adoption is in no manner diminished by any recitation of facts, issues and conclusions herein, or

of any failure to mention a matter of fact or law.

The Acting Deputy Administrator finds that Respondent is a psychiatrist who received his medical degree from a school in Guadalajara, Mexico, and became board certified in psychiatry in April 1981. In October 1981, Respondent moved to Warren, Pennsylvania where he established a private practice and also became the medical director of the psychiatric unit of Warren General Hospital. In 1982, the hospital suspended Respondent's hospital staff privileges, and in 1985, his hospital privileges were permanently revoked. According to Respondent, this action was taken by the hospital as a result of a scheme by county officials to take a piece of Respondent's property that was in a desirable location, and to force Respondent to become a county employee. In addition, Respondent testified that county officials made false accusations about his professional competence and tried to force him into selling his property to the county at a loss.

According to Respondent, he was told by hospital officials that if he resigned from the hospital, his employment record would not reflect the suspension and revocation of his staff privileges. Thereafter, Respondent resigned from the hospital. Subsequently, Respondent had a job offer in Ohio and he applied for an Ohio medical license. This application was denied by the Ohio licensing agency (Ohio Board) because he did not disclose on the application that he had lost his hospital privileges in Pennsylvania. Respondent testified that he did not disclose the hospital's action because he relied upon the promises of the hospital officials that his employment record would not reflect such action. Other than his own assertions, Respondent did not offer any evidence to corroborate that such an agreement with the hospital existed.

As a result of the Ohio Board's action, the New York licensing agency (New York Board) suspended Respondent's license to practice medicine in that state because of his misrepresentations on the Ohio application for licensure. It appears that the New York Board stayed the suspension. Subsequently, in 1987, the Pennsylvania State Board of Medicine (Pennsylvania Board) suspended his Pennsylvania medical license for two years based on his misrepresentations to Ohio, stayed the suspension, and placed Respondent on probation.

In 1989, Respondent filed a civil action in the United States District Court for the Western District of Pennsylvania against Warren General

Hospital and various county officials, claiming that their actions violated both his constitutional rights and antitrust laws. The Acting Deputy Administrator finds it significant to note that Respondent did not mention in his civil suit the purported promises made by the hospital officials that his employment records would not reflect the suspension and revocation of his hospital privileges if Respondent resigned from the hospital. The court granted summary judgement for the hospital and county officials, finding that Respondent presented neither direct nor circumstantial evidence sufficient to establish the existence of a conspiracy and Respondent's case was based on "little more than his own suspicions and beliefs." At the hearing before Judge Bittner, Respondent contended that the lawyer representing him in the civil suit had many personal problems and therefore was ineffective in her representation of Respondent.

On May 25, 1994, Respondent was involuntarily committed to the psychiatric unit of a local Pennsylvania hospital after a mental health review officer found that he posed a danger to others. Respondent was released after 20 days and on June 13, 1994, Respondent's Pennsylvania medical license was automatically suspended. Respondent testified that his involuntary commitment was a result of untrue accusations made by his wife. Following an evaluation and report by an independent psychiatrist who "did not find any psychiatric impairment which would prevent [Respondent] from making adequate medical judgements in the practice of medicine," the Pennsylvania Board reinstated Respondent's medical license on March 28, 1995.

Regarding the DEA applications that are the subject of these proceedings, the Acting Deputy Administrator finds that in 1992, Respondent submitted an application for renewal of his DEA Certificate of Registration issued to him in Pennsylvania. On this application, Respondent answered "no" to the liability question which asks: "Has the applicant ever been convicted in connection with controlled substances under State or Federal law or surrendered or had a Federal controlled substance registration revoked, suspended, restricted or denied or ever had a professional license or controlled substance registration revoked, suspended, denied, restricted or placed on probation?" In 1994, Respondent's registration was transferred from Pennsylvania to California. Thereafter, on May 24, 1995, Respondent executed another renewal application for his DEA

registration. Respondent answered the same liability question in the negative as he had done on his 1992 renewal application. On the 1995 renewal application, Respondent crossed out the pre-printed California address and wrote in an address in Pennsylvania. DEA interpreted this alteration on the application to be a request by Respondent to modify his DEA registration by changing the address.

After receiving the 1995 renewal application, DEA sent a letter to Respondent dated August 16, 1995, offering Respondent the opportunity to voluntarily surrender his DEA registration in lieu of the initiation of proceedings to revoke his registration, in light of his failure to disclose on the renewal applications actions taken by state licensing agencies. In addition, Respondent was informed that because revocation proceedings would be initiated should Respondent not surrender his registration, Respondent's request to modify his registration from California to Pennsylvania would not be approved at that time. Respondent was further advised in the letter that as a result, he was not authorized to handle controlled substance in Pennsylvania.

On August 25, 1995, Respondent responded by filing a civil action in the United States District Court for the Eastern District of Pennsylvania against two DEA employees, claiming both a violation of his civil rights and defamation. A hearing was held by the court on August 28, 1995, to determine whether DEA should be temporarily restrained from taking action against Respondent's DEA Certificate of Registration. At his hearing, Respondent argued that all state disciplinary action against him stemmed from his problems at Warren General Hospital and from his reliance on the promises made by hospital officials that his loss of hospital privileges would not be reflected in his employment records if he resigned from the hospital. Respondent also argued that the liability question on the DEA applications was ambiguous, and that he had at some point contacted DEA headquarters in order to clarify the meaning of the question on the applications. Respondent asserted that some DEA employee told him to answer the question in the negative since the actions taken by the state boards did not pertain to his handling of controlled substances. The court denied Respondent's request for a temporary restraining order against the DEA finding that Respondent, instead of accepting responsibility for answering the liability question on the applications incorrectly, tried to blame an unidentified DEA employee. The court

ultimately dismissed Respondent's civil complaint against the two DEA employees on March 1, 1996, on the grounds that Respondent failed to effect proper service on the defendants.

At the hearing before Judge Bittner, Respondent reiterated his contention that in answering the liability question on his application for Ohio licensure, he relied upon the representations made by Warren General Hospital officials that his employment record would not reflect that he had lost his hospital privileges. However, the Acting Deputy Administrator finds that Respondent did not present evidence to corroborate this contention. In addition, Respondent testified at the hearing before Judge Bittner that in answering the liability question on the DEA renewal applications regarding whether any action had been taken against a state professional license, he relied upon the advice of an unidentified DEA employee. Respondent was not able to remember the name of the person with whom he spoke, nor the position of the individual. Again, Respondent did not offer any evidence to corroborate his assertion.

The Deputy Administrator, in his discretion, may revoke a DEA Certificate of Registration and deny any renewal applications if the registrant "has materially falsified any application filed pursuant to or required by this subchapter. * * * 21 U.S.C. 824(a)(1). In addition, the Deputy Administrator may also revoke a DEA Certificate of Registration and deny any pending applications for registration "if he determines that the issuance of such registration would be inconsistent with the public interest." 21 U.S.C. 823(f) and 824(a)(4). A request for modification of registration is considered an application for registration pursuant to 21 CFR 1301.51.

In determining whether or not a registration would be inconsistent with the public interest, the Deputy Administrator is to consider the following factors set forth in 21 U.S.C. 823(f):

- (1) The recommendation of the appropriate State licensing board or professional disciplinary authority.
- (2) The applicant's experience in dispensing, or conducting research with respect to controlled substances.
- (3) The applicant's conviction record under Federal or State laws relating to the manufacture, distribution, or dispensing of controlled substances.
- (4) Compliance with applicable State, Federal, or local laws relating to controlled substances.
- (5) Such other conduct which may threaten the public health and safety.

In considering whether revocation of Respondent's DEA Certificate of Registration is appropriate under 21 U.S.C. 824(a)(1), the Acting Deputy Administration finds that it is undisputed that Ohio denied Respondent's application for a license to practice medicine; that New York suspended Respondent's medical license; that in 1987, Pennsylvania suspended Respondent's medical license and then placed it on probation; and that beginning in June 1994, Respondent's Pennsylvania medical license was suspended for nine and one half-months. It is also undisputed that Respondent answered a question on both his 1992 and 1995 applications for renewal of this DEA registration indicating that no action had ever been taken against any of his professional licenses.

DEA has previously held that in finding that there has been a material falsification of an application, it must be determined that the applicant knew or should have known that the response given to the liability question was false. See *Bobby Watts, M.D.*, 58 FR 4699 (1993); *Hebert J. Robinson, M.D.*, 59 FR 6304 (1994).

Like Judge Bittner, the Acting Deputy Administrator does not find credible Respondent's explanation for why he did not disclose the loss of his hospital privileges in Pennsylvania on his application for an Ohio medical license which resulted in the denial of the application and the subsequent actions taken against his New York and Pennsylvania medical licenses. Respondent did not provide any corroborating evidence that the hospital staff in Pennsylvania agreed to remove any reference to Respondent's loss of staff privileges if he resigned. In addition, the Acting Deputy Administrator does not find credible Respondent's assertion that he incorrectly answered the liability question on his DEA renewal applications because some unidentified DEA employee told him to do so. Therefore, the Acting Deputy Administrator concludes that Respondent knew or should have known that his response to the liability question was false and consequently, grounds exist to revoke Respondent's DEA Certificate of Registration pursuant to 21 U.S.C. 824(a)(1). The question now becomes whether the Acting Deputy Administrator, in exercising his discretion, believes that revocation is the appropriate sanction in light of the facts and circumstances of this case. See, *Martha Hernandez, M.D.*, 62 FR 61,145 (1997).

The Acting Deputy Administrator concludes that revocation is warranted in this case. Respondent has repeatedly failed to acknowledge and accept responsibility for his falsifications of his applications. Instead, Respondent tries to blame others for his predicament. Respondent contends that officials of Warren General Hospital and county officials in Pennsylvania are to blame for the Ohio Board action; that the fact that Ohio's action was entered in the National Practitioner Databank is to blame for the New York Board action and the Pennsylvania Board action in 1987; that his wife is to blame for the 1994 Pennsylvania Board action; and that the ambiguity of the liability question and an unidentified DEA employee are to blame for his incorrect answer on the DEA renewal applications. This failure to accept responsibility raises serious questions as to Respondent's ability to accept the responsibilities inherent in a DEA registration.

In considering whether grounds exist to deny Respondent's request to modify his DEA registration and to revoke the registration pursuant to 21 U.S.C. 823(f) and 824(a)(4), it should be noted that the factors specified in 21 U.S.C. 823(f) are to be considered in this disjunctive. The Deputy Administrator may rely on any one or a combination of those factors, and give each factor the weight he deems appropriate, in determining whether a registration should be revoked or an application for registration denied. See *Henry J. Schwarz, Jr., M.D.*, 54 FR 16,422 (1989).

As to factor one, it is undisputed that Respondent is currently licensed to practice medicine in Pennsylvania and therefore authorized to handle controlled substances in that state.

However, as Judge Bittner notes, "although state authorization to handle controlled substances is a necessary condition for Respondent's registration with DEA, it is not dispositive of the question of whether his continued registration would be in the public interest." Regarding factors two and four, no evidence was placed in the record by either party regarding Respondent's experience in handling controlled substances, or his compliance with applicable laws relating to controlled substances. Likewise there is no evidence in the record that Respondent has ever been convicted of a controlled substance offense as referred to in factor three. However, Respondent's material falsification of his 1992 and 1995 applications for renewal of his DEA registration are clearly significant under factor five.

The Administrative Law Judge found that Respondent's material falsification of these applications, as well as his failure to accept responsibility for his actions support a finding that his continued registration would be inconsistent with the public interest and therefore revocation of his DEA registration is appropriate. Judge Bittner also recommended that denial of Respondent's request for modification of this registration is appropriate.

Respondent in his exceptions argues that Judge Bittner wrongly ignored and disallowed some of Respondent's evidence. The Acting Deputy Administrator has considered all of the evidence presented at the hearing in this matter and agrees with Judge Bittner's evidentiary rulings. Also in his exceptions, Respondent contends that there are witnesses available to corroborate his version of events and attempts to introduce documents into the record that were not presented at the hearing. The Acting Deputy Administrator has not considered this information because Respondent has not offered any explanation as to why he did not present this evidence at the hearing in this matter. In addition, Respondent argues that DEA has admitted that the question on its application is ambiguous because it has since modified the question on the application. The Acting Deputy Administrator concludes that the liability question on the applications at issue is not ambiguous. The fact that DEA has since modified the application does not support a conclusion that DEA has admitted otherwise. Respondent also asserts that his registration should not be revoked because "at no time did I try to deceive." But, as the Acting Deputy Administrator has previously held, a registration may be revoked whether or not there is any intent by the applicant to deceive. See, *Martha Hernandez, M.D.*, 62 FR 61,145 (1997). Finally, Respondent claims that "the crime for which I am accused, condemned and sentenced is this and only this. I checked the wrong box on a renewal form for a DEA Certificate." The Acting Deputy Administrator finds that Respondent's attempt to minimize his actions is further support for the revocation of his DEA registration. Truthful answers to the liability questions on the application are extremely important, since they alert DEA as to whether further investigation of the applicant is necessary. See *Bobby Watts, M.D.*, 58 FR 46,995 (1993); *Ezzat E. Majd Pour, M.D.*, 55 FR 47,547 (1990). The Acting Deputy Administrator concludes that in light of Respondent's material falsification of his applications

for renewal of his DEA registration, and his persistent attempts to blame others for his predicament, Respondent's request to modify his DEA registration must be denied and his DEA Certificate of Registration must be revoked.

Accordingly, the Acting Deputy Administrator of the Drug Enforcement Administration, pursuant to the authority vested in him by 21 U.S.C. 823 and 824 and 28 C.F.R. 0.100(b) and 0.104, hereby orders that DEA Certificate of Registration AW8019033, issued to Richard S. Wagner, M.D., be and it hereby is, revoked. The Acting Deputy Administrator further orders that Dr. Wagner's request to modify his registration, and any pending applications for renewal of such registration, be, and they hereby are, denied. This order is effective March 12, 1998.

Dated: February 2, 1998.

Peter F. Gruden,

Acting Deputy Administrator.

[FR Doc. 98-3217 Filed 2-9-98; 8:45 am]

BILLING CODE 4410-09-M

DEPARTMENT OF LABOR

Employment and Training Administration

Proposed Information Collection Request Submitted for Public Comment and Recommendations; Procedures for Classifying Labor Surplus Areas

ACTION: Notice.

SUMMARY: The Department of Labor, as part of its continuing effort to reduce paperwork and respondent burden, conducts a preclearance consultation program to provide the general public and Federal agencies with an opportunity to comment on proposed and/or continuing collections of information in accordance with the Paperwork Reduction Act of 1995 (PRA95) (44 U.S.C. 3506(c)(2)(A)). This program helps to ensure that requested data can be provided in the desired format, reporting burden (time and financial resources) is minimized, collection instruments are clearly understood, and the impact of collection requirements on respondents can be properly assessed. Currently, the Employment and Training Administration is soliciting comments concerning the proposed extension of the information collection for Procedures Classifying Labor Surplus Areas.

A copy of the proposed information collection request can be obtained by

contacting the employee listed below in the contact section of this notice.

DATE: Written comments must be submitted on or before April 13, 1998.

Written comments should evaluate whether the proposed information collection is necessary for the proper performance of the functions of the agency, including whether the information will have practical utility; evaluate the accuracy of the agency's estimate of the burden of the proposed collection of information including the validity of the methodology and assumptions used; enhance the quality, utility, and clarity of the information to be collected; and minimize the burden of the collection of information on those who are to respond, including through the use of appropriate automated, electronic, mechanical, or other technological collection techniques or other forms of information technology, e.g., permitting electronic submission of responses.

ADDRESSES: William McGarrity, U.S. Employment Service, Employment and Training Administration, Department of Labor Room N-4470, 200 Constitution Avenue, N.W., Washington, D.C. 20210, 202-219-5185, ext. 129. (This is not a toll-free number)

SUPPLEMENTARY INFORMATION:

I. Background

Under Executive Orders 12073 and 10582, the Secretary of Labor is required to classify labor surplus areas (LSAs) and disseminate this information for the use of Federal agencies. Federal agencies utilize LSA classifications for various purposes including procurement decisions, food stamp waiver decisions, certain Small Business loan decisions, as well as other purposes determined by the agencies. The LSA listings are issued annually, effective October 1 of each year, utilizing data from the Bureau of Labor Statistics. Areas meeting the criteria are classified as Labor Surplus Areas.

The Department's regulations specify that the Department can add other areas to the annual LSA listing under the exceptional circumstance criteria. Such additions are based upon information contained in petitions submitted by the State employment security agencies (SESAs) to the national office of the Employment and Training Administration. These petitions contain specific economic information about an area in order to provide ample justification for adding the area to the LSA listing under the exceptional circumstance criteria. An area is eligible for classification as an LSA if it meets all of the criteria, and if the exceptional

circumstance event is not temporary or seasonal. This data collection pertains only to data submitted voluntarily by States in exceptional circumstance petitions.

II. Current Actions

This is a request for OMB approval under the Paperwork Reduction Act of 1995 (44 U.S.C. 3506(c)(2)(A)) of an extension to an existing collection of information previously approved and assigned OMB Control No. 1205-0207. There is no change in burden.

Type of Review: Extension.

Agency: Employment and Training Administration, Labor.

Titles: Procedures for Classifying Labor Surplus Areas.

OMB Number: 1205-0207.

Frequency: On occasion.

Affected Public: States.

Number of Respondents: 52.

Estimated Time Per Respondent:

Item	States	Annual hours	Total hour
Petitions	52	4	208

Estimated Burden Hours: 208.

Total Estimated Cost: \$5,000.00.

Comments submitted in response to this will be summarized and/or included in the request for Office of Management and Budget approval of the information collection request; they will also become a matter of public record.

Dated: February 3, 1998.

John R. Beverly, III,

Director, U.S. Employment Service.

[FR Doc. 98-3342 Filed 2-9-98; 8:45 am]

BILLING CODE 4510-30-M

DEPARTMENT OF LABOR

Employment and Training Administration

Federal-State Unemployment Compensation Program; Unemployment Insurance Program Letters Interpreting Federal Unemployment Insurance Law

The Employment and Training Administration interprets Federal law requirements pertaining to unemployment compensation (UC) as part of its role in the administration of the Federal-State UC program. These interpretations are issued in Unemployment Insurance Program Letters (UIPLs) to the State Employment Security Agencies. The UIPLs described below are published in the Federal Register in order to inform the public.

UIPL 08-98

Federal law authorizes withdrawals from a State's unemployment fund only with respect to an individual's unemployment. This means that payment of UC from the State's unemployment fund is limited to periods in which an individual has experienced unemployment. UIPL 08-98 is issued to remind the States that their UC laws must contain this limitation. Whether an individual is unemployed depends on whether the individual has suffered a loss of work—an actual reduction in hours worked. It is not sufficient that the individual merely have reduced earnings. If just wages, and not also hours worked, are

used as a measure for unemployment, then it is possible that an individual moving from a high- to low-paying job could be eligible for UC without having experienced unemployment. Thus, each State's law must contain language to prevent payment of UC to individuals who have experienced no unemployment for the period being compensated.

UIPL 09-98

UIPL 09-98 advises States of the Department's position concerning State-wide personnel actions such as hiring freezes, shutdowns and furloughs. The service delivery needs of the UC program must first be taken into account. When a State subjects its UC

program to State-wide personnel actions, the State will be required to address how its workload will be handled without a decline in performance and demonstrate it has adequately addressed those activities funded by Federal dollars. This position is consistent with one of the basic purposes of the "methods of administration" requirement of section 303(a)(1) of the Social Security Act—to assure the proper and prompt delivery of UC services to claimants and employers.

Dated: January 29, 1998.

Raymond J. Uhalde,
Acting Assistant Secretary of Labor.

BILLING CODE 4510-30-P

U. S. Department of Labor Employment and Training Administration Washington, D.C. 20210	CLASSIFICATION UI
	CORRESPONDENCE SYMBOL TEUL
	DATE January 12, 1998.

DIRECTIVE : UNEMPLOYMENT INSURANCE PROGRAM LETTER NO. 08-98

TO : ALL STATE EMPLOYMENT SECURITY AGENCIES

FROM : GRACE A. KILBANE *Grace A. Kilbane*
 Director
 Unemployment Insurance Service

SUBJECT : Unemployment Compensation (UC) - Payment Only for
 Periods of Unemployment

1. Purpose. To remind States that Federal law limits the payment of UC to periods when an individual has experienced unemployment.

2. References. Section 303(a)(5) of the Social Security Act (SSA) and Sections 3304(a)(4) and 3306(h) of the Federal Unemployment Tax Act (FUTA); Employment and Training Administration Glossary of Program Terms and Definitions, ET Handbook No. 373 (Glossary).

3. Background. Since the inception of the UC program, Federal law has authorized withdrawals from a State's unemployment fund only with respect to an individual's unemployment. Put another way, Federal law limits the payment of UC to periods in which an individual has experienced unemployment, that is, an actual reduction in hours worked. As the result of questions arising from a review of a State's law, this UIPL is being issued to remind all States that their laws must contain this limitation.

This UIPL addresses only whether an individual has experienced unemployment. It does not address other eligibility conditions related to the term "unemployment" such as able and available requirements.

4. Discussion. Section 3304(a)(4), FUTA, requires, as a condition for employers in a State to receive credit against the

RESCISSIONS None	EXPIRATION DATE Continuing
----------------------------	--------------------------------------

Federal tax, that State law provide that:

all money withdrawn from the unemployment fund of the State shall be used solely in the payment of unemployment compensation, exclusive of expenses of administration, and for refunds of sums erroneously paid into such fund. . . .

Section 303(a)(5), SSA, contains the same requirement as a condition for receiving administrative grants. Section 3306(h), FUTA, defines compensation as "cash benefits payable to individuals with respect to their unemployment." Thus, Federal law permits withdrawals from a State's unemployment fund only with respect to an individual's "unemployment."

The 1935 Senate Report on the original Social Security Act also emphasized that UC may be paid only with respect to an individual's unemployment:

Unemployment compensation differs from relief in that payments are made as a matter of right not on a needs basis, but only while the worker is involuntarily unemployed. . . . Payment of compensation is conditioned upon continued involuntary unemployment. [S. Rep. No. 628, 74th Cong., 1st Sess. 11 (1935).]

On January 31, 1939, the Social Security Board, which at that time had Federal jurisdiction for the UC program, also concluded that unemployment must exist for UC to be payable:

[S]ince . . . any benefits paid under a State law must be paid with respect to unemployment, a State's plan for the payment of partial benefits must safeguard against the payment for reduced earnings without accompanying unemployment.

Thus, whether an individual is unemployed within the meaning of Federal law depends on whether the individual has suffered a loss of work. It is not sufficient that the individual merely have reduced earnings.

The Department uses the phrase "partial benefits" to describe "UC of less than the full weekly benefit amount payable to a claimant."¹ Partial benefits may be paid for a period of "part-total unemployment" when an individual has odd jobs or subsidiary work with other than the individual's regular employer, or

¹This and the definitions of "partial" and "part-total" unemployment and "full-time week" are taken from the Glossary.

"partial unemployment" in which an individual works less than regular full-time hours for his/her regular employer. (Short-time compensation is a form of "partial unemployment.")

5. Effect on State laws. State laws must be fashioned so as to prevent payment of UC to individuals who have experienced no unemployment for the period being compensated. Whether a payment of partial benefits may be made is determined by whether the individual has actually experienced unemployment. If wages are used as the only surrogate for unemployment, it may be possible that an individual, who moves from a high-paying job to a low-paying job, could experience no unemployment, or even see hours worked increased, and still be eligible for benefits. To avoid this, State law must contain a test which ensures that the individual has, in fact, experienced unemployment.

Generally, States provide for partial UC benefits through provisions of State law which specify the individual must be "unemployed." Usually States determine if the individual has worked less than a full-time week where "full-time week" means the number of hours or days per week currently established by schedule, custom, or otherwise, as constituting a week of full-time work for the kind of service an individual performs for an employing unit.

6. Action Required. Each State should take appropriate action to ensure that its law is consistent with the above requirements.

7. Inquiries. Inquiries should be directed to the appropriate Regional Office.

U. S. Department of Labor Employment and Training Administration Washington, D.C. 20210	CLASSIFICATION UI
	CORRESPONDENCE SYMBOL TEUL
	DATE January 12, 1998

DIRECTIVE : UNEMPLOYMENT INSURANCE PROGRAM LETTER NO. 09-98
TO : ALL STATE EMPLOYMENT, SECURITY AGENCIES
FROM : GRACE A. KILBANE *Grace A. Kilbane*
 Director
 Unemployment Insurance Service
SUBJECT : Application of State-Wide Personnel Actions,
 including Hiring Freezes, to the Unemployment
 Insurance (UI) Program

1. Purpose. To advise States of the Department's position concerning the application of State-wide personnel actions such as hiring freezes, shutdowns and furloughs to the UI program.

2. References. Section 303(a)(1) of the Social Security Act (SSA).

3. Background. Due to State budget constraints, some States have, in the past, imposed hiring freezes, furloughs and other actions on a State-wide basis. These actions are usually taken during economic downturns when State revenues decline while the demand for UI services increases.

State UI agencies have objected to being subjected to these State fiscal actions on the basis that, because Federal UI grants may only be used for UI purposes, there are no savings to the State budget. The Department has supported the UI agencies in articulating this argument. The Department has noted that these actions will likely have a detrimental effect on unemployed workers and businesses and result in decreased performance against Federal standards. Finally, the Department has noted that, since the amount of

RESCISSIONS None	EXPIRATION DATE Continuing
---------------------	-------------------------------

Federal funds provided to a State takes into account the State's workload, Federal funding for UI increases during downturns. In spite of these objections, the UI program has been subjected to these fiscal restrictions.

As a result, the Department has re-examined this matter to determine whether a more proactive stance may be taken to assure the continued delivery of UI services during downturns. This UIPL is issued to advise States of the Department's determination and its basis in Federal law.

4. Department's Position. Section 303(a)(1), SSA, requires, as a condition of a State receiving grants for the administration of its UI law, that State law provide for--

Such methods of administration . . . as are found by the Secretary of Labor to be reasonably calculated to insure full payment of unemployment compensation when due;

One of the basic purposes of this "methods of administration" requirement is to assure the proper and prompt delivery of UI services to claimants and employers. Therefore, any action that does not take into account the service delivery needs of the UI program, is not a "method of administration" consistent with Section 303(a)(1), SSA. This position applies to all State-wide personnel actions, including hiring freezes, shutdowns, furloughs, across-the-board staff reductions, and any process that serves to delay the hiring of UI staff when additional staff is needed.

When a State subjects the UI program to State-wide personnel actions, the State will be required to demonstrate to the Department that it has adequately addressed the UI program's needs. These needs include all activities funded by Federal dollars - payments, determinations, appeals, integrity and tax functions, etc. The State will be required to address how its workload will be handled without a decline in performance. If a State fails to show that its actions adequately take into account the needs of its UI program, then the action is not an acceptable "method of administration" under the SSA and the State's entire UI grant could be at risk. Similarly, if State performance declines despite the State's "showing" that program needs have been considered, then the action may not be an acceptable "method of administration."

The Department recognizes that there may be situations where hiring freezes, staff reductions or other personnel actions taken by the UI agency are necessary. For example, when workload decreases, the need for staff decreases and the UI agency will need to take appropriate action to assure that only amounts necessary for the proper and efficient administration of the UI program are expended from grant funds. Since these actions take into account the needs of the UI program, they raise no issue under Federal law.

5. Action Required. State agency administrators are requested to provide this UIPL to appropriate staff.

6. Inquiries. Direct questions to your Regional Office.

[FR Doc. 98-3341 Filed 2-9-98; 8:45 am]

BILLING CODE 4510-30-C

NATIONAL ARCHIVES AND RECORDS ADMINISTRATION

Agency Information Collection Activities: Submission for OMB Review; Comment Request

AGENCY: National Archives and Records Administration (NARA).

ACTION: Notice.

SUMMARY: NARA is giving public notice that the agency has submitted to OMB for approval the information collection described in this notice. The public is invited to comment on the proposed information collections pursuant to the Paperwork Reduction Act of 1995.

DATES: Written comments must be submitted to OMB at the address below on or before March 12, 1998 to be assured of consideration.

ADDRESSES: Comments should be sent to: Office of Information and Regulatory Affairs, Office of Management and Budget, Attn: Ms. Maya Bernstein, Desk Officer for NARA, Washington, DC 20503.

FOR FURTHER INFORMATION CONTACT: Requests for additional information or copies of the proposed information collection and supporting statement should be directed to Tamee Fechhelm at telephone number 301-713-6730 or fax number 301-713-6913.

SUPPLEMENTARY INFORMATION: Pursuant to the Paperwork Reduction Act of 1995 (Pub. L. 104-13), NARA invites the general public and other Federal agencies to comment on proposed information collections. NARA published a notice of proposed collection for this information collection on August 19, 1997 (62 FR 44151). No comments were received. NARA has submitted the described information collection to OMB for approval.

In response to this notice, comments and suggestions should address one or more of the following points: (a) whether the proposed collection information is necessary for the proper performance of the functions of NARA; (b) the accuracy of NARA's estimate of the burden of the proposed information collections; (c) ways to enhance the quality, utility, and clarity of the information to be collected; and (d) ways to minimize the burden of the collection of information on respondents, including the use of information technology. In this notice, NARA is soliciting comments concerning the following information collection:

Title: Request Pertaining to Military Service.

OMB number: 3095-0029.

Agency form number: Standard Form (SF) 180 and NA Form 13075.

Type of review: Regular.

Affected public: Veterans, their authorized representatives, state and local governments, and businesses.

Estimated number of respondents: 713,400.

Estimated time per response: 5 minutes for the SF 180 and NA Form 13075.

Frequency of response: On occasion (when respondents wish to request information from military service records).

Estimated total annual burden hours: 207,689 hours.

Abstract: Individuals and interested public and private sector agencies write to the National Personnel Records Center (NPRC) to request information from military service records, using letters or Standard Forms 180, Request Pertaining to Military Records. NPRC uses the information provided in letters and on Standard Forms 180 to locate requested records or information. In cases where the information provided by requesters is not sufficient to locate requested records or information, NPRC asks requesters to furnish additional information on NA Forms 13075, Questionnaire About Military Service. A major fire at NPRC on July 12, 1973, destroyed a number of military service records. If requests involve records or information that may be from records that were lost in the fire, NPRC also asks requesters to complete NA Forms 13075, so that NPRC can search alternative sources to reconstruct basic military service data.

Dated: February 3, 1998.

L. Reynolds Cahoon,

Assistant Archivist for Human Resources and Information Services.

[FR Doc. 98-3338 Filed 2-9-98; 8:45 am]

BILLING CODE 7515-01-P

NATIONAL SKILL STANDARDS BOARD

Notice of Open Meeting

AGENCY: National Skill Standards Board.

ACTION: Notice of open meeting.

SUMMARY: The National Skill Standards Board was established by an Act of Congress, the National Skill Standards Act, Title V, Pub. L. 103-227. The 27-member National Skill Standards Board will serve as a catalyst and be responsible for the development and implementation of a national system of voluntary skill standards and certification through voluntary partnership which have the full and

balanced participation of business, industry, labor, education and other key groups.

Time and Place: The meeting will be held from 8:30 a.m. to approximately 1:30 p.m. on Friday, February 20, 1998 in the Hampton Room of the Omni Shoreham Hotel located at 2500 Calvert Street, NW, Washington, DC 20008.

Agenda: The agenda for the Board Meeting will include: an update on the Board's Strategic Plan; updates from the Board's committees; and presentations from the new Convening Groups representing the following industries: Finance & Insurance; Restaurants, Hotels, & Hospitality; Construction; Education & Training; and Communications, Entertainment, & Information.

Public Participation: The meeting, from 8:30 a.m. to 1:30 p.m., is open to the public. Seating is limited and will be available on first-come, first-served basis. Seats will be reserved for the media. Individuals with disabilities should contact Pat Warfield at (202) 254-8628, if special accommodations are needed.

FOR FURTHER INFORMATION CONTACT: Tracy Marshall, Manager of Program Operations at (202) 254-8628.

Signed at Washington, D.C., this 4th day of February, 1998.

Edie West,

Executive Director, National Skill Standards Board.

[FR Doc. 98-3343 Filed 2-9-98; 8:45 am]

BILLING CODE 4510-23-M

NUCLEAR REGULATORY COMMISSION

Agency Information Collection Activities: Proposed Collection; Comment Request

AGENCY: U.S. Nuclear Regulatory Commission (NRC).

ACTION: Notice of pending NRC action to submit an information collection request to OMB and solicitation of public comment.

SUMMARY: The NRC is preparing a submittal to OMB for review of continued approval of information collections under the provisions of the Paperwork Reduction Act of 1995 (44 U.S.C. Chapter 35).

Information pertaining to the requirement to be submitted:

1. *The title of the information collection:* 10 CFR Part 19, "Notices, Instructions, and Reports to Workers: Inspection and Investigations"

2. *Current OMB approval number:* 3150-0044

3. *How often the collection is required:* As necessary in order that adequate and timely reports of radiation exposure be made to individuals involved in NRC-licensed activities.

4. *Who is required or asked to report:* Licensees authorized to receive, possess, use, or transfer material licensed by the NRC.

5. *The number of annual respondents:* 280

6. *The number of hours needed annually to complete the requirement or request:* 39,918 (approximately 34,566 reporting hours—an average of 5 minutes per response, and 5,352 recordkeeping hours—an average of 18 hours per recordkeeper)

7. *Abstract:* Title 10 of the Code of Federal Regulations, Part 19, requires licensees to advise workers on an annual basis of any radiation exposure they may have received as a result of NRC-licensed activities or when certain conditions are met. These conditions apply during termination of the worker's employment, at the request of a worker, former worker, or when the worker's employer (the NRC licensee) must report radiation exposure information on the worker to the NRC. Part 19 also establishes requirements for instructions by licensees to individuals participating in licensed activities and options available to these individuals in connection with Commission inspections of licensees to ascertain compliance with the provisions of the Atomic Energy Act of 1954, as amended, Title II of the Energy Reorganization Act of 1974, and regulations, orders and licenses thereunder regarding radiological working conditions.

The worker should be informed of the radiation dose he or she receives because: (a) that information is needed by both a new employer and the individual when the employee changes jobs in the nuclear industry; (b) the individual needs to know the radiation dose received as a result of an accident or incident (if this dose is in excess of the 10 CFR Part 20 limits) so that he or she can seek counseling about future work involving radiation, medical attention, or both, as desired; and (c) since long-term exposure to radiation may be an adverse health factor, the individual needs to know whether the accumulated dose is being controlled within NRC limits. The worker also needs to know about health risks from occupational exposure to radioactive materials or radiation, precautions or procedures to minimize exposure, worker responsibilities and options to report any licensee conditions which may lead to or cause a violation of Commission regulations, and individual

radiation exposure reports which are available to him.

Submit, by April 13, 1998, comments that address the following questions:

1. Is the proposed collection of information necessary for the NRC to properly perform its functions? Does the information have practical utility?
2. Is the burden estimate accurate?
3. Is there a way to enhance the quality, utility, and clarity of the information to be collected?
4. How can the burden of the information collection be minimized, including the use of automated collection techniques or other forms of information technology?

A copy of the draft supporting statement may be viewed free of charge at the NRC Public Document Room, 2120 L Street, NW (lower level), Washington, DC. OMB clearance packages are available at the NRC worldwide web site (<http://www.nrc.gov>) under the FedWorld collection link on the home page tool bar. The document will be available on the NRC home page site for 60 days after the signature date of this notice.

Comments and questions about the information collection requirements may be directed to the NRC Clearance Officer, Brenda Jo. Shelton, U.S. Nuclear Regulatory Commission, T-6 F33, Washington, DC, 20555-0001, or by telephone at 301-415-7233, or by Internet electronic mail at BJS1@NRC.GOV.

Dated at Rockville, Maryland, this 3rd day of February, 1998.

For the Nuclear Regulatory Commission.

Brenda Jo. Shelton,
NRC Clearance Officer, Office of the Chief Information Officer.

[FR Doc. 98-3271 Filed 2-9-98; 8:45 am]

BILLING CODE 7590-01-P

NUCLEAR REGULATORY COMMISSION

[Docket Nos. 50-317 and 50-318]

Baltimore Gas & Electric Company (Calvert Cliffs Nuclear Power Plant, Units 1 and 2); Exemption

I

The Baltimore Gas & Electric Company (BGE or the licensee) is the holder of Facility Operating License Nos. DPR-53 and DPR-69, which authorize operation of the Calvert Cliffs Nuclear Power Plant, Units 1 and 2 (the facilities), respectively. The license provides, among other things, that the facilities are subject to all rules, regulations, and orders of the U.S. Nuclear Regulatory Commission (NRC

or the Commission) now or hereafter in effect.

The facilities are pressurized-water reactors located at the licensee's site in Calvert County, Maryland.

The licensee is implementing an upgrade to the existing Calvert Cliffs Unit 1 emergency diesel generator (EDG) 1B during the upcoming Unit 1 refueling outage (RFO-14). RFO-14 is scheduled to commence on April 3, 1998, and is expected to be completed in early June 1998. To support the upgrade, the licensee has identified one temporary exemption required at this time. The exemption is specified below.

II

The *Code of Federal Regulations* at 10 CFR Part 50, Appendix A, General Criterion 2 (GDC-2) requires that structures, systems, and components important to safety be designed to withstand the effects of natural phenomena, such as tornadoes, without the loss of capability to perform their safety functions.

The licensee has requested the temporary exemption from GDC-2 because of the planned upgrade of the Unit 1 EDG 1B. The effort will require temporary removal of two steel doors, which will expose the out-of-service Unit 1 EDG 1B and the operating Unit 2 EDGs 2A and 2B, as well as the support systems for the out-of-service Unit 1 EDG 1B and the operating Unit 2 EDGs 2A and 2B. Unit 2 EDGs 2A and 2B must be operable to support the operation of Unit 2. These EDGs require protection from the effects of missiles, generated by natural phenomena.

The licensee indicates that the steel missile doors will be removed four times during RFO-14; only one door will be removed at a time. The licensee estimates that each of the missile door removals will take less than 24 hours, which will result in a total removal time of about 100 hours during the scheduled 60-day outage.

The licensee is providing compensatory action to ensure the safe operation of Unit 2, for the short periods that the steel missile doors will be removed. To cover all severe weather conditions, as defined in the plant site Emergency Response Plan Implementing Procedures 3.0, Attachment 17, a concerted effort will be made to reinstall the missile doors if a tornado or a hurricane watch is issued or if sustained winds are predicted to be greater than 50 miles an hour at the site. When the missile shield is removed, it is left connected to the crane used to remove it. A crane operator remains at the crane controls during the time the missile shield is removed. In addition to

the crane operator, three people are used to handle the movement of the shield and fasten it in place. These people are drawn from the crew working on the diesel upgrade since the shield is removed only when they are working in the area. The time required to reinstall the missile shield is approximately 1 hour and 15 minutes. This time includes 30 minutes to 45 minutes to move and position the shield, and 30 minutes to completely torque a minimum of 13 bolts to hold it in place. The installation time is considered sufficient since plant procedures require that the missile shield be reinstalled on an adverse weather watch, rather than waiting until a warning is issued. The only factor that would impede the reinstallation of the missile doors would be the safety of the individuals performing the reinstallation. The licensee has also stated that the missile doors between the EDG 1B room and the EDG 2A room is a fire barrier but not a flood barrier. The fire barrier will be breached when the door is removed to pass EDG parts through. Plant procedures require a fire watch if any fire barrier is to remain open. The procedures will be followed from the time the door is removed until it is replaced.

Considering the existing design features and the compensatory measures proposed by the licensee, the likelihood of damage to the exposed EDGs and the support systems from postulated missiles generated by natural phenomena is minimal for the short periods that the protective doors will be removed. Also, on the basis of the compensatory measure provided, reasonable assurance exists that the ability to reinstall the missile doors will be maintained during any severe weather that could result in airborne missiles. Therefore, there is reasonable assurance that the proposed GDC-2 exemption will present no undue risk to public health and safety.

III

The Commission has determined, pursuant to 10 CFR 50.12(a), that special circumstances, as set forth in 10 CFR 50.12(a)(2)(v), exist. The exemption would provide only temporary relief from the applicable regulation (GDC-2). The exemption is requested for a specific period, after which the facility would again be in conformance with all the requirements of GDC-2. The licensee has made good faith efforts in considering alternatives to the exemption request and has concluded that without the subject exemption, the EDG upgrade can only be conducted when both units are shut down.

On the basis of this information and review of the licensee's submittal, as summarized in the Safety Evaluation, the NRC staff concludes that the likelihood of unacceptable damage to the exposed portions of the operable EDGs and support systems as a result of weather-induced missiles during short-duration exposures in the exemption period is low.

On the basis of the low probability of the occurrence of unacceptable events, coupled with the compensatory measure to which the licensee has committed, the NRC staff finds the proposed exemption from GDC-2 to be acceptable.

IV

Accordingly, the Commission has determined that pursuant to 10 CFR 50.12, the subject exemption is authorized by law, will not present an undue risk to public health and safety, and is consistent with the common defense and security. The Commission further determines that special circumstances, as provided in 10 CFR 50.12(a)(2)(v), are present that justify the exemption; namely, that the exemption would provide only temporary relief from the applicable regulations and that the licensee has made good faith efforts to comply with the regulations.

Therefore, the Commission hereby approves the following exemption: Calvert Cliffs Nuclear Power Plant, Units 1 and 2, may operate without conforming to the requirements of GDC-2 as they apply to the exposed portions of the Unit 2 EDGs 2A and 2B and the support systems for the EDGs, providing that the compensatory measure, as described herein, is in place for the period of the exemption.

Pursuant to 10 CFR 51.32, the Commission has determined that granting the above exemption will have no significant impact on the quality of the human environment (62 FR 114).

The subject Unit No. 1 EDG 1B upgrade GDC-2 exemption is effective from the date of issuance through July 31, 1998.

Dated at Rockville, Maryland, this 4th day of February 1998.

For the Nuclear Regulatory Commission.

Samuel J. Collins,
Director, Office of Nuclear Reactor Regulation.

[FR Doc. 98-3272 Filed 2-9-98; 8:45 am]

BILLING CODE 7590-01-P

NUCLEAR REGULATORY COMMISSION

[Docket Nos. 50-269, 50-270, and 50-287]

Duke Energy Corporation; Notice of Consideration of Issuance of Amendments to Facility Operating Licenses, Proposed No Significant Hazards Consideration Determination, and Opportunity for a Hearing

The U.S. Nuclear Regulatory Commission (the Commission) is considering issuance of amendments to Facility Operating License Nos. DPR-38, DPR-47, and DPR-55, issued to the Duke Energy Corporation (the licensee), for operation of the Oconee Nuclear Station, Units 1, 2, and 3, respectively, located in Seneca, South Carolina.

If approved, the proposed amendments would amend the Oconee Nuclear Station, Units 1, 2, and 3 Technical Specifications (TS) to revise the present wording used to specify refueling outage surveillances to indicate that the surveillances are to be performed on an 18-month frequency.

The original Oconee TS required that certain surveillances be performed annually and, therefore, were not constrained to performance with a unit in the refueling condition. As a result, the licensee has not interpreted a surveillance that is specified to be performed at refueling outage frequency as meaning that the unit must be in a refueling outage to satisfy the requirement. Therefore, some surveillances specified at a refueling outage frequency were performed at times other than during a refueling outage. In discussions with the NRC staff on January 29, 1998, the licensee was informed of the staff's interpretation of Oconee's TS that concluded any surveillance that was specified to be performed during refueling outages must be performed with the unit in a refueling outage. Thus, any surveillances performed at power, in past forced outages, or during planned shutdowns, would not satisfy the TS requirements. The licensee then immediately began to evaluate the impact of the staff's literal interpretation of the TS. On January 30, 1998, the licensee confirmed that certain surveillances had been performed at times other than during a refueling outage and that implementation of the staff's interpretation of the surveillances designated in the TS as "refueling outage" would result in exceeding the time constraints allowed in the TS and, in accordance with TS 3.0, would result in the forced shutdown of Units 2 and 3 and interfere with the planned startup of Unit 1. However, the licensee

determined that all surveillances that are presently required to be performed during refueling outages have been performed within the required interval (22.5 months), even though some have been performed with the unit in a condition other than a refueling outage. Thus, the surveillance interval requirements have been satisfied.

When these findings were discussed with the staff on January 30, 1998, a Notice of Enforcement Discretion was issued verbally on January 30, 1998, to exercise discretion not to enforce compliance with TS 3.0 for these surveillances for the period from 3:30 p.m. on January 30, 1998, until issuance of the related amendments. The request for license amendments was submitted by letter dated February 2, 1998. Since the proposed amendments are designed to complete the review process and implement the proposed TS changes, pursuant to the NRC's policy regarding exercising discretion for an operating facility set out in Section VII.c of the "General Statement of Policy and Procedures for NRC Enforcement Actions" (Enforcement Policy), NUREG-1600, and be effective for the period until the issuance of a related TS amendment, these circumstances require that the amendments be processed under exigent circumstances.

Before issuance of the proposed license amendment, the Commission will have made findings required by the Atomic Energy Act of 1954, as amended (the Act) and the Commission's regulations.

Pursuant to 10 CFR 50.91(a)(6) for amendments to be granted under exigent circumstances, the NRC staff must determine that the amendment request involves no significant hazards consideration. Under the Commission's regulations in 10 CFR 50.92, this means that operation of the facility in accordance with the proposed amendments would not (1) involve a significant increase in the probability or consequences of an accident previously evaluated; or (2) create the possibility of a new or different kind of accident from any accident previously evaluated; or (3) involve a significant reduction in a margin of safety. As required by 10 CFR 50.91(a), the licensee has provided its analysis of the issue of no significant hazards consideration, which is presented below:

This proposed change has been evaluated against the standards in 10 CFR 50.92 and has been determined to involve no significant hazards, in that operation of the facility in accordance with the proposed amendment would not:

1. Involve a significant increase in the probability or consequences of an accident previously evaluated?

No. The proposed change will revise the surveillance requirements for selected surveillances which have a refueling outage surveillance frequency with a maximum interval of 22 months and 15 days. The proposed change will replace the refueling outage requirement with a comparable requirement to perform the surveillance every 18 months which has a maximum interval of 22 months and 15 days. The proposed change does not increase the maximum interval between surveillances and does not change any surveillance acceptance criteria. Thus, the probability and consequences of an accident previously evaluated will not be significant[ly] increased.

2. Create the possibility of a new or different kind of accident from the accidents previously evaluated?

No. Since the proposed change does not increase the maximum interval between surveillances and does not change any surveillance acceptance criteria, a new or different kind of accident from the accidents which were previously evaluated will not occur.

3. Involve a significant reduction in a margin of safety?

No. The margin of safety will not be significantly reduced by this amendment request because the maximum interval between the surveillances and the surveillance acceptance criteria are not changed. Thus, the operability of the plant equipment and systems will be verified within the same surveillance interval and to the same acceptance criteria.

Duke has concluded based on the above information that there are no significant hazards involved in this amendment request.

The NRC staff has reviewed the licensee's analysis and, based on this review, it appears that the three standards of 10 CFR 50.92(c) are satisfied. Therefore, the NRC staff proposes to determine that the amendment request involves no significant hazards consideration.

The Commission is seeking public comments on this proposed determination. Any comments received within 14 days after the date of publication of this notice will be considered in making any final determination.

Normally, the Commission will not issue the amendment until the expiration of the 14-day notice period. However, should circumstances change during the notice period, such that failure to act in a timely way would result, for example, in derating or shutdown of the facility, the Commission may issue the license amendment before the expiration of the 14-day notice period, provided that its final determination is that the amendment involves no significant hazards consideration. The final

determination will consider all public and State comments received. Should the Commission take this action, it will publish in the Federal Register a notice of issuance. The Commission expects that the need to take this action will occur very infrequently.

Written comments may be submitted by mail to the Chief, Rules and Directives Branch, Division of Administrative Services, Office of Administration, U.S. Nuclear Regulatory Commission, Washington, DC 20555-0001, and should cite the publication date and page number of this Federal Register notice. Written comments may also be delivered to Room 6D22, Two White Flint North, 11545 Rockville Pike, Rockville, Maryland, from 7:30 a.m. to 4:15 p.m. Federal workdays. Copies of written comments received may be examined at the NRC Public Document Room, the Gelman Building, 2120 L Street, NW., Washington, DC. The filing of requests for hearing and petitions for leave to intervene is discussed below.

By March 12, 1998, the licensee may file a request for a hearing with respect to issuance of the amendment to the subject facility operating license and any person whose interest may be affected by this proceeding and who wishes to participate as a party in the proceeding must file a written request for a hearing and a petition for leave to intervene. Requests for a hearing and a petition for leave to intervene shall be filed in accordance with the Commission's "Rules of Practice for Domestic Licensing Proceedings" in 10 CFR Part 2. Interested persons should consult a current copy of 10 CFR 2.714 which is available at the Commission's Public Document Room, the Gelman Building, 2120 L Street, NW., Washington, DC, and at the local public document room located at the Oconee County Library, 501 West South Broad Street, Walhalla, South Carolina. If a request for a hearing or petition for leave to intervene is filed by the above date, the Commission or an Atomic Safety and Licensing Board, designated by the Commission or by the Chairman of the Atomic Safety and Licensing Board Panel, will rule on the request and/or petition; and the Secretary or the designated Atomic Safety and Licensing Board will issue a notice of hearing or an appropriate order.

As required by 10 CFR 2.714, a petition for leave to intervene shall set forth with particularity the interest of the petitioner in the proceeding, and how that interest may be affected by the results of the proceeding. The petition should specifically explain the reasons why intervention should be permitted

with particular reference to the following factors: (1) The nature of the petitioner's right under the Act to be made a party to the proceeding; (2) the nature and extent of the petitioner's property, financial, or other interest in the proceeding; and (3) the possible effect of any order which may be entered in the proceeding on the petitioner's interest. The petition should also identify the specific aspect(s) of the subject matter of the proceeding as to which petitioner wishes to intervene. Any person who has filed a petition for leave to intervene or who has been admitted as a party may amend the petition without requesting leave of the Board up to 15 days prior to the first prehearing conference scheduled in the proceeding, but such an amended petition must satisfy the specificity requirements described above.

Not later than 15 days prior to the first prehearing conference scheduled in the proceeding, a petitioner shall file a supplement to the petition to intervene which must include a list of the contentions which are sought to be litigated in the matter. Each contention must consist of a specific statement of the issue of law or fact to be raised or controverted. In addition, the petitioner shall provide a brief explanation of the bases of the contention and a concise statement of the alleged facts or expert opinion which support the contention and on which the petitioner intends to rely in proving the contention at the hearing. The petitioner must also provide references to those specific sources and documents of which the petitioner is aware and on which the petitioner intends to rely to establish those facts or expert opinion. Petitioner must provide sufficient information to show that a genuine dispute exists with the applicant on a material issue of law or fact. Contentions shall be limited to matters within the scope of the amendment under consideration. The contention must be one which, if proven, would entitle the petitioner to relief. A petitioner who fails to file such a supplement which satisfies these requirements with respect to at least one contention will not be permitted to participate as a party.

Those permitted to intervene become parties to the proceeding, subject to any limitations in the order granting leave to intervene, and have the opportunity to participate fully in the conduct of the hearing, including the opportunity to present evidence and cross-examine witnesses.

If the amendment is issued before the expiration of the 30-day hearing period, the Commission will make a final determination on the issue of no

significant hazards consideration. If a hearing is requested, the final determination will serve to decide when the hearing is held.

If the final determination is that the amendment request involves no significant hazards consideration, the Commission may issue the amendment and make it immediately effective, notwithstanding the request for a hearing. Any hearing held would take place after issuance of the amendment.

If the final determination is that the amendment request involves a significant hazards consideration, any hearing held would take place before the issuance of any amendment.

A request for a hearing or a petition for leave to intervene must be filed with the Secretary of the Commission, U.S. Nuclear Regulatory Commission, Washington, DC 20555-0001, Attention: Rulemakings and Adjudications Staff, may be delivered to the Commission's Public Document Room, the Gelman Building, 2120 L Street, NW., Washington, DC, by the above date. A copy of the petition should also be sent to the Office of the General Counsel, U.S. Nuclear Regulatory Commission, Washington, DC 20555-0001, and to Mr. J. Michael McGarry, III, Winston and Strawn, 1200 17th Street, NW., Washington, DC 20036, attorney for the licensee.

Nontimely filings of petitions for leave to intervene, amended petitions, supplemental petitions and/or requests for hearing will not be entertained absent a determination by the Commission, the presiding officer or the presiding Atomic Safety and Licensing Board that the petition and/or request should be granted based upon a balancing of the factors specified in 10 CFR 2.714(a)(1)(i)-(v) and 2.714(d).

For further details with respect to this action, see the application for amendment dated February 2, 1998, which is available for public inspection at the Commission's Public Document Room, the Gelman Building, 2120 L Street, NW., Washington, DC, and at the local public document room, located at the Oconee County Library, 501 West South Broad Street, Walhalla, South Carolina.

Dated at Rockville, Maryland, this 5th day of February 1998.

For the Nuclear Regulatory Commission.
David E. LaBarge,
Senior Project Manager, Project Directorate II-2, Division of Reactor Projects—I/II, Office of Nuclear Reactor Regulation.
 [FR Doc. 98-3270 Filed 2-9-98; 8:45 am]
 BILLING CODE 7590-01-P

NUCLEAR REGULATORY COMMISSION

Sunshine Act Meeting

AGENCY HOLDING THE MEETING: Nuclear Regulatory Commission.

DATES: Weeks of February 9, 16, 23, and March 2, 1998.

PLACE: Commissioner's Conference Room, 11555 Rockville Pike, Rockville, Maryland.

STATUS: Public and Closed.

MATTERS TO BE CONSIDERED:

Week of February 9

There are no meetings the week of February 9.

Week of February 16—Tentative

Wednesday, February 18

2:00 p.m.—Briefing on Investigative Matters (Closed—Ex. 5 & 7).

Thursday, February 19

9:30 a.m.—Meeting with Northeast Nuclear on Millstone (Public Meeting) (Contact: Bill Travers, 301-415-1200).

12:00 m.—Affirmation Session (Public Meeting) (if needed).

Week of February 23—Tentative

There are no meetings the week of February 23.

Week of March 2—Tentative

There are no meetings the week of March 2.

* The schedule for Commission meetings is subject to change on short notice. To verify the status of meeting call (Recording)—(301) 415-1292. Contact Person for more information: Bill Hill (301) 415-1661.

The NRC Commission Meeting Schedule can be found on the Internet at:

<http://www.nrc.gov/SECY/smj/schedule.htm>

This notice is distributed by mail to several hundred subscribers; if you no longer wish to receive it, or would like to be added to it, please contact the Office of the Secretary, Attn: Operations Branch, Washington, D.C. 20555 (301-415-1661).

In addition, distribution of this meeting notice over the Internet system is available. If you are interested in receiving this Commission meeting schedule electronically, please send an electronic message to wmh@nrc.gov or dkw@nrc.gov.

Dated: February 2, 1998.
 William M. Hill, Jr.,
 Secy, Tracking Officer, Office of the Secretary.
 [FR Doc. 98-3464 Filed 2-6-98; 8:45 am]
 BILLING CODE 7590-01-M

RAILROAD RETIREMENT BOARD

Proposed Collection; Comment Request

SUMMARY: In accordance with the requirement of Section 3506 (c)(2)(A) of the Paperwork Reduction Act of 1995 which provides opportunity for public comment on new or revised data collections, the Railroad Retirement Board (RRB) will publish periodic summaries of proposed data collections.

Comments are invited on: (a) Whether the proposed information collection is necessary for the proper performance of the functions of the agency, including whether the information has practical utility; (b) the accuracy of the RRB's estimate of the burden of the collection of the information; (c) ways to enhance the quality, utility, and clarity of the information to be collected; and (d) ways to minimize the burden related to the collection of information on respondents, including the use of automated collection techniques or other forms of information technology.

Title and purpose of information collection: Placement Service; OMB 3220-0057. Section 12(i) of the Railroad Unemployment Insurance Act (RUIA),

authorizes the Railroad Retirement Board (RRB) to establish, maintain, and operate free employment offices to provide claimants for unemployment benefits with job placement opportunities. Section 704(d) of the Regional Railroad Reorganization Act of 1973, as amended, and as extended by the consolidated Omnibus Budget Reconciliation Act of 1985, required the RRB to maintain and distribute a list of railroad job vacancies, by class and craft, based on information furnished by rail carriers to the RRB. Although this requirement under the law expired effective August 13, 1987, the RRB has continued to obtain this information in keeping with its employment service responsibilities under Section 12(k) of the RUIA. Application procedures for the job placement program are prescribed in 20 CFR 325. The procedures pertaining to the RRB's obtaining and distributing job vacancy reports furnished by rail carriers are described in 20 CFR 346.1.

The RRB utilizes six forms to obtain information needed to carry out its job placement responsibilities. Form ES-2, Supplemental Information for Central Register, is used by the RRB to obtain information needed to update a computerized central register of separated and furloughed railroad employees available for employment in the railroad industry. Form ES-20a, Notice of Employment Referral and Form ES-20b, Notice of Employment

Referral (Employer), are used by the RRB to refer unemployed railroad employees to local employers (railroad and nonrailroad). Form ES-21, Referral to State Employment Service, and ES-21c, Report of State Employment Service Office are used by the RRB to provide placement assistance for unemployed railroad employees through arrangements with State Employment Service offices. Form UI-35, Field Office Record of Claimant Interview, is used primarily by RRB Field Office staff to conduct in-person interviews of claimants for unemployment benefits. Completion of these forms are required to obtain or maintain a benefit. The RRB proposes to revise all of the forms to incorporate language required by the Paperwork Reduction Act of 1995. Minor editorial and formatting changes are also being proposed.

In addition, the RRB also collects job vacancy information received voluntarily from railroad employers (currently OMB 3220-0122, Railroad Job Vacancies). The RRB proposes to merge the Railroad Job Vacancies information collection into the Placement Service information collection. Minor nonburden impacting changes are being proposed to the Railroad Job Vacancies portion of the information collection.

Estimate of Annual Respondent Burden

The estimated annual respondent burden for this collection is as follows:

Form number(s)	Annual responses	Completion time (minutes)	Burden (hours)
ES-2	7,500	0.25	31
ES-20a	2,000	0.75	25
ES-20b	2,000	0.50	17
ES-21	3,500	0.68	40
ES-21c	1,250	1.50	31
UI-35 (in-person)	9,000	7.00	1,050
UI-35 (by mail)	1,000	10.50	175
Railroad Job Vacancies Report	750	10.00	125
Total	27,000		1,494

ADDITIONAL INFORMATION OR COMMENTS:

To request more information or to obtain a copy of the information collection justification, forms, and/or supporting material, please call the RRB Clearance Officer at (312) 751-3363. Comments regarding the information collection should be addressed to Ronald J. Hodapp, Railroad Retirement Board, 844 North Rush Street, Chicago, Illinois 60611-2092. Written comments

should be received within 60 days of this notice.

Chuck Mierzwa,
 Clearance Officer.
 [FR Doc. 98-3222 Filed 2-9-98; 8:45 am]
 BILLING CODE 7905-01-M

SECURITIES AND EXCHANGE COMMISSION

[Release No. 34-39617; File No. SR-BSE-97-6]

Self-Regulatory Organizations; Notice of Filing and Immediate Effectiveness of Proposed Rule Change by Boston Stock Exchange, Inc., Relating to its BEACON Liability Rule

February 3, 1998.

Pursuant to Section 19(b)(1) of the Securities Exchange Act of 1934

("Act"),¹ notice is hereby given that on January 20, 1998, the Boston Stock Exchange, Inc. ("Exchange") filed with the Securities and Exchange Commission the proposed rule as described in Items I, II and III below, which items have been prepared by the self-regulatory organization.² The Commission is publishing this notice to solicit comments on the proposed rule from interested persons.

I. Self-Regulatory Organization's Statement of the Terms of Substance of the Proposed Rule Change

The Exchange seeks to modify its rule regarding losses sustained by members as a result of their use of the Boston Exchange Automated-Surveillance Monitoring System.

II. Self-Regulatory Organization's Statement of the Purpose of, and Statutory Basis for, the Proposed Rule Change

In its filing with the Commission, the self-regulatory organization included statements concerning the purpose of and basis for the proposed rule change. The text of these statements may be examined at the places specified in Item IV below. The self-regulatory organization has prepared summaries, set forth in sections A, B and C below, of the most significant aspects of such statements.

A. Self-Regulatory Organization's Statement of the Purpose of, and Statutory Basis for, the Proposed Rule Change

1. Purpose

The purpose of the proposed rule change is to bring the Exchange's BEAM system within the purview of Chapter XXXIII, Section 7 (BEACON Liability). This section disclaims Exchange liability for losses related to the BEACON system, from which the BEAM system receives its data "feed." Whereas losses related to the BEACON system are determined by the appearance of an order on the Member Firm Interface Safe-Store file, BEAM related losses are assessed directly to the affected member

¹ 15 U.S.C. 78s(b)(1).

² See letter from Thomas Frain, Staff Attorney, Exchange, to Kevin Ehrlich, Attorney, Division of Market Regulation, Commission, dated January 20, 1998 ("Amendment No. 1"). The Exchange originally submitted the proposal on October 6, 1997. However, Amendment No. 1, which is a substantive amendment, restricts the scope of the filing by limiting the Exchange's BEAM-related disclaimer to instances involving a member or member organization's reliance on the Boston Exchange Automated Communication Order-routing Network ("BEACON") data feed to the Boston Exchange-Automated Monitoring ("BEAM") system.

or member organization utilizing the BEAM system.

2. Statutory Basis

The Exchange believes the proposed rule change is consistent with Section 6(b) of the Act³ in general and furthers the objectives of Section 6(b)(5)⁴ of the Act in that the proposed rule change is designed to promote just and equitable principles of trade; to foster cooperation and coordination with persons engaged in regulating, clearing, settling, processing information with respect to, and facilitating transactions in securities; to remove impediments to and perfect the mechanism of a free and open market and a national market system; and in general, to protect investors and the public interest; and is not designed to permit unfair discrimination between customers, issuers, brokers, or dealers.

B. Self-Regulatory Organization's Statement on Burden on Competition

The Exchange does not believe that the proposed rule change will impose any burden on competition that is not necessary or appropriate in furtherance of the purposes of the Act.

C. Self-Regulatory Organization's Statement on Comments on the Proposed Rule Change Received From Members, Participants or Others

The Exchange has neither solicited nor received comments on the proposed rule change.

III. Date of Effectiveness of the Proposed Rule Change and Timing for Commission Action

The Exchange has asserted that the proposed rule change (i) will not significantly affect the protection of investors or the public interest; (ii) will not impose any significant burden on competition; and (iii) will not become operative for 30 days after the date of this filing. The proposed rule change was originally submitted to the Commission on October 6, 1997. However, the submission of substantive Amendment No. 1 on January 20, 1998 delays the statutorily required implementation date to February 19, 1998.⁵ For the foregoing reasons, the rule filing will become operative as a "non-controversial" rule change pursuant to Rule 19b-4(e)(6) under the

³ 15 U.S.C. 78f(b).

⁴ 15 U.S.C. 78f(b)(5).

⁵ The Commission notes that any substantive amendment to a proposed rule change filed under Section (e)(6) of Rule 19b-4 causes the 30 day delayed implementation period to be restarted from the date of the filing of the amendment.

Act.⁶ The Commission notes that the Exchange did not submit a pre-filing of this proposal to the staff five days prior to the formal filing of the proposal. However, the staff has determined to waive the pre-filing requirement.

At any time within 60 days of the filing of the proposed rule change, the Commission may summarily abrogate such rule change if it appears to the Commission that such action is necessary or appropriate in the public interest, for the protection of investors, or otherwise in the furtherance of the purposes of the Act.

IV. Solicitation of Comments

Interested persons are invited to submit written data, views and arguments concerning the foregoing, including whether the proposed rule change is consistent with the Act. Persons making written submissions should file six copies thereof with the Secretary, Securities and Exchange Commission, 450 Fifth Street, N.W., Washington, D.C. 20549. Copies of the submission, all subsequent amendments, all written statements with respect to the proposed rule change that are filed with the Commission, and all written communications relating to the proposed rule change between the Commission and any person, other than those that may be withheld from the public in accordance with the provisions of 5 U.S.C. § 552, will be available for inspection and copying in the Commission's Public Reference Room. Copies of the filing will also be available for inspection and copying at the principal office of the Exchange. All submissions should refer to the file number SR-BSE-97-6 and should be submitted by March 3, 1998.

For the Commission by the Division of Market Regulation, pursuant to delegated authority.⁷

Margaret H. McFarland,

Deputy Secretary.

[FR Doc. 98-3277 Filed 2-9-98; 8:45 am]

BILLING CODE 8010-01-M

⁶ 17 CFR 240.19b-4.

⁷ 17 CFR 200.30-3(a)(12).

SECURITIES AND EXCHANGE COMMISSION

[Release No. 34-39613; File No. SR-NASD-97-83]

Self-Regulatory Organizations; National Association of Securities Dealers, Inc.; Order Approving Proposed Rule Change Relating to Listing Fees for Nasdaq National Market Issuers

February 2, 1998.

I. Introduction

On November 13, 1997, the National Association of Securities Dealers, Inc. ("NASD" or "Association"), through its wholly owned subsidiary, the Nasdaq Stock Market, Inc. ("Nasdaq"), filed with the Securities and Exchange Commission ("SEC" or "Commission") the proposed rule change pursuant to Section 19(b)(1) of the Securities Exchange Act of 1934 ("Act")¹ and Rule 19b-4 thereunder² to amend Nasdaq listing fees for Nasdaq National Market issuers. On December 3, 1997, the NASD filed Amendment No. 1 to the proposal.³

Notice of the proposed rule change, including Amendment No. 1, was published in the *Federal Register*.⁴ One comment was received, which is described below.

II. Description of the Proposal

Nasdaq's proposal would amend NASD Rule 4510 to revise the fees for Nasdaq National Market issuers and would make conforming changes to NASD Rule 4520. The proposed rule change will adjust both the Entry Fee and the Annual Fee for Nasdaq National Market issuers, effective January 1, 1998. Nasdaq has determined that an increase in the Entry Fee and the Annual Fee for issuers included on the Nasdaq National Market is necessary. Nasdaq has not filed an adjustment to its fee rates since the fall of 1991. Nasdaq has represented that, since that time, it has committed increased resources in efforts to strengthen market qualifications, to communicate with investors, and to prepare for closer integration of the world's equity markets.

The proposed rule change also revises references to the type of information on which the fees are based to include, in

addition to the issuer's most recent periodic report required to be filed with the issuer's appropriate regulatory authority, more recent information held by Nasdaq. The NASD has made other technical changes to Rules 4510 and 4520.

III. Summary of Comments

One commenter responded to the proposal.⁵ The commenter, which opposed the proposal, indicates that it is a Nasdaq-listed company and, as a result, would be subject to the proposed fee increase. The commenter argues that the proposed increase in the listing fee is "excessive," contending that Nasdaq collects fees in excess of the level of its costs. The commenter also states that many of Nasdaq's enhancements are electronic and should reduce mailing and paper costs. The commenter expresses concern that a "significant portion" of the Nasdaq budget "has gone to administrative salaries, overhead and marketing." The commenter notes that it has been approached by an exchange regarding listing there and indicates that the proposed fee increase will increase the likelihood that the commenter will in fact delist from Nasdaq and pursue another marketplace for listing.

By letter dated January 23, 1998, Nasdaq responded to the comment letter.⁶ In its response, Nasdaq states that, with respect to the commenter's assertion that the proposed issuer listing fee increase is excessive, Nasdaq has not increased fees since the fall of 1991. Nasdaq re-emphasizes a point made in its initial filing, that "since 1991 Nasdaq has committed increased resources in efforts to strengthen market qualifications, to communicate with investors, and to prepare for close integration of the world's equity markets." Nasdaq also notes its development of new information services for investors and issuers, such as nasdaq.com and Nasdaq Online. Nasdaq states that such additional services were not envisioned when the 1991 filing fee was instated.

Nasdaq further notes in its response letter that the fee increase also would be used "to support the continued expansion and technological enhancements of Nasdaq's qualification and market surveillance systems and

programs." Nasdaq believes that such initiatives will "enhance the overall quality of companies listed on Nasdaq, foster the protection of investors, and promote the integrity of The Nasdaq Stock Market." Nasdaq asserts that the proposed fee increase "reflects additional costs that Nasdaq incurs for services provided to issuers."

IV. Discussion

The Commission finds that the proposed rule change is consistent with the requirements of the Act and the rules and regulations thereunder applicable to a national securities association, and, in particular, Sections 15A(b)(5) and 15A(b)(6) of the Act. Section 15A(b)(5) requires that the rules of a national securities association provide for the equitable allocation of reasonable dues, fees, and other charges among members and issuers using the Nasdaq system. Section 15A(b)(6) requires, among other things, that the rules of a national securities association not be designed to permit unfair discrimination between customers, issuers, brokers, or dealers.

Since 1991, the last time that the NASD raised the fees it charges issuers, there has been tremendous change in the Nasdaq stock market, both in terms of volume and market developments. Volume on Nasdaq has increased significantly over the past several years, suggesting that investor interest in Nasdaq-listed companies is growing. This growth has resulted in investor expectations for Nasdaq to render services commensurate with its market position. For example, the NASD represented in its proposal that during the last eighteen months Nasdaq has incurred substantial incremental annual expenses in developing and implementing new information services for issuers and investors. These services include nasdaq.com and Nasdaq Online. While the NASD believes that such services add value to a Nasdaq listing, the associated costs were not envisioned in 1991 when issuer listing fees were set at their current levels.

The NASD has represented that the proposed fee increase will also be used to support the continued expansion and technological enhancements of Nasdaq's qualification and market surveillance systems and programs. Initiatives include the development of an automated issuer risk assessment system and an automated Internet surveillance system. The NASD has represented that additional resources will be committed to additional listing qualifications staff to ensure compliance with the recently approved increase in Nasdaq's listing

¹ 15 U.S.C. § 78s(b)(1).

² 17 CFR 240.19b-4.

³ See Letter from Robert E. Aber, Vice President and General Counsel, Nasdaq, to Katherine A. England, Assistant Director, Division of Market Regulation, Commission, dated December 3, 1997.

⁴ Securities Exchange Act Release No. 39441 (Dec. 11, 1997), 62 FR 66707 (Dec. 19, 1997)

⁵ See Letter from James R. Maronick, Vice President, Finance, Crown Resources, to Douglas A. Patterson, Senior Vice President, Nasdaq, dated Dec. 19, 1997 (copy of which was forwarded to the Division of Market Regulation, Commission).

⁶ See Letter from Arnold P. Golub, Attorney, Nasdaq, to Katherine England, Esq., Assistant Director, Division of Market Regulation, Commission, dated January 23, 1998.

requirements.⁷ These initiatives, in concert with the additional services that Nasdaq is providing to companies and investors, should enhance the overall quality of companies listed on Nasdaq, foster the protection of investors, and promote the integrity of The Nasdaq Stock Market.

Because the fee increases are allocated equitably and do not discriminate between issuers, the Commission believes that the proposal is consistent with Sections 15A(b)(5) and 15A(b)(6) of the Act. Although one commenter has argued that the fee increases are excessive, the Commission notes that no other issuer expressed similar views. Even the single commenter indicated that there may be a suitable alternative to paying the increased fees (*i.e.*, by listing on another marketplace).

V. Conclusion

It is therefore ordered, pursuant to Section 19(b)(2) of the Act,⁸ that the proposed rule change (SR-NASD-97-83) be, and hereby, is approved.⁹

For the Commission, by the Division of Market Regulation, pursuant to delegated authority.¹⁰

Margaret H. McFarland,
Deputy Secretary.

[FR Doc. 98-3278 Filed 2-9-98; 8:45 am]
BILLING CODE 8010-01-M

SECURITIES AND EXCHANGE COMMISSION

[Release No. 34-39616; File No. SR-PHLX 97-49]

Self-Regulatory Organizations; Order Granting Approval to Proposed Rule Change and Amendment No. 1 Thereto by the Philadelphia Stock Exchange, Inc., Relating to Exchange Approval of Member Advertising

February 3, 1998.

I. Introduction

On November 13, 1997, pursuant to Section 19(b)(1) of the Securities Exchange Act of 1934 ("Act")¹ and Rule 19b-4 thereunder,² the Philadelphia

⁷ See Securities Exchange Act Release No. 38961 (Aug. 22, 1997), 62 FR 45895 (Aug. 29, 1997).

⁸ 15 U.S.C. § 78s(b)(2).

⁹ In approving this rule, the Commission has considered the proposed rule's impact on efficiency, competition and capital formation. The proposed rule change should not have a materially adverse impact on the issuer listing process due to the robust competition among marketplaces to attract issuers. The net effect of approving the proposed rule change will be positive. 15 U.S.C. § 78c(f).

¹⁰ 17 CFR 200.30-3(a)(12).

¹ 15 U.S.C. 78s(b)(1)/

² 17 CFR 240.19b-4.

Stock Exchange, Inc. ("Phlx" or "Exchange") filed with the Securities and Exchange Commission ("SEC" or "Commission") a proposed rule change (SR-PHLX-97-49) to require Exchange approval of member advertising. On December 15, 1997, the Exchange filed Amendment No. 1 to the proposed rule change. The proposed rule change was published for comment in the *Federal Register* on December 29, 1997.³ No comments were received on the proposal. This order approves the proposal.

II. Description of the Proposal

In the rule proposal, the Phlx proposed to amend Phlx Rule 605 to require member or foreign currency option participant organizations for which the Phlx is the designated examining authority ("DEA"): (1) to receive Exchange consent prior to using the Internet to provide market quotations or to advertise to the general public; (2) to receive prior Exchange consent before making use of radio or television broadcasts for any business purpose or broadcasting Exchange quotations on radio or television programs or via public telephone reports; and (3) to submit the text of all commercials or program materials about securities or investing sponsored by the firm on radio, television, public telephone or on the Internet, promptly following the program in which it was used. Further, the commentary to the rule which states that the provisions of the rule do not apply to advertisements, market letters and sales literature relating to options as defined in Rule 1049 would be deleted so that the rule would apply to all products traded on the Exchange, including, options. The Exchange filed Amendment No. 1 to make clear that print advertisements are also subject to prior Exchange review and approval under the new proposed language of Phlx Rule 605.

III. Discussion

After careful review, the Commission finds that the proposed rule change is consistent with the requirements of the Act and the rules and regulations thereunder. The Commission believes the proposal is consistent with the requirements of section 6 of the Act in general, and in particular, with Section 6(b)(5), in that it is designed to promote just and equitable principles of trade, prevent fraudulent and manipulative

³ See Securities Exchange Act Release No. 39466 (December 18, 1997), 62 FR 67680.

acts and practices, and to protect investors and the public interest.⁴

The Commission believes that it is beneficial and in the public interest to add a layer of review to the advertisements of Phlx members. The Commission believes that the review process will protect investors because it will help prevent misleading advertisements and fraudulent practices.

IV. Conclusion

It is therefore ordered, pursuant to Section 19(b)(2) of the Act,⁵ that the proposed rule change (SR-PHLX-97-49) is approved.

For the Commission, by the Division of Market Regulation, pursuant to delegated authority.⁶

Margaret H. McFarland,
Deputy Secretary.

[FR Doc. 98-3276 Filed 2-9-98; 8:45 am]
BILLING CODE 8010-01-M

SMALL BUSINESS ADMINISTRATION

Reporting and Recordkeeping Requirements Under OMB Review

ACTION: Notice of reporting requirements submitted for review.

SUMMARY: Under the provisions of the Paperwork Reduction Act (44 U.S.C. Chapter 35), agencies are required to submit proposed reporting and recordkeeping requirements to OMB for review and approval, and to publish a notice in the *Federal Register* notifying the public that the agency has made such a submission.

DATES: Comments should be submitted on or before March 12, 1998. If you intend to comment but cannot prepare comments promptly, please advise the OMB Reviewer and the Agency Clearance Officer before the deadline.

COPIES: Request for clearance (OMB 83-1), supporting statement, and other documents submitted to OMB for review may be obtained from the Agency Clearance Officer. Submit comments to the Agency Clearance Officer and the OMB Reviewer.

FOR FURTHER INFORMATION CONTACT:

Agency Clearance Officer: Jacqueline White, Small Business Administration, 409 3rd Street, S.W., 5th Floor, Washington, D.C. 20416, Telephone: (202) 205-6629.

⁴ In approving this rule, the Commission notes that it has also considered the proposed rule's impact on efficiency, competition, and capital formation. 15 U.S.C. 78(c)(f).

⁵ 15 U.S.C. 78s(b)(2).

⁶ 17 CFR 200.30-3(a)(12).

OMB Reviewer: Victoria Wassmer, Office of Information and Regulatory Affairs, Office of Management and Budget, New Executive Office Building, Washington, D.C. 20503.

Title: CBIS Financial Reports.

Form No: SBA Form 468.

Frequency: On Occasion.

Description of Respondents: Small Business Investment Companies.

Annual Responses: 325.

Annual Burden: 5,185.

Dated: February 2, 1998.

Jacqueline White,

Chief, Administrative Information Branch.

[FR Doc. 98-3122 Filed 2-9-98; 8:45 am]

BILLING CODE 8025-01-M

SMALL BUSINESS ADMINISTRATION

Reporting and Recordkeeping Requirements Submitted for Review

ACTION: Notice of reporting requirements submitted for review.

SUMMARY: Under the provisions of the Paperwork Reduction Act (44 U.S.C. Chapter 35), agencies are required to submit proposed reporting and recordkeeping requirements to OMB for review and approval, and to publish a notice in the *Federal Register* notifying the public that the agency has made such a submission.

DATES: Comments should be submitted on or before March 12, 1998. If you intend to comment but cannot prepare comments promptly, please advise the OMB Reviewer and the Agency Clearance Officer before the deadline.

COPIES: Request for clearance (OMB 83-1), supporting statement, and other documents submitted to OMB for review may be obtained from the Agency Clearance Officer. Submit comments to the Agency Clearance Officer and the OMB Reviewer.

FOR FURTHER INFORMATION CONTACT:

Agency Clearance Officer: Jacqueline White, Small Business Administration, 409 3rd Street, SW., 5th Floor, Washington, DC 20416, Telephone: (202) 205-6629.

OMB Reviewer: Victoria Wassmer, Office of Information and Regulatory Affairs, Office of Management and Budget, New Executive Office Building, Washington, DC 20503.

Title: Portfolio Financing Report.

Form No's: SBA Form 1031.

Frequency: On Occasion.

Description of Respondents: Small Business Investment Companies.

Annual Responses: 2,100.

Annual Burden: 420.

Dated: February 2, 1998.

Jacqueline White,

Chief, Administrative Information Branch.

[FR Doc. 98-3123 Filed 2-9-98; 8:45 am]

BILLING CODE 8025-01-P

OFFICE OF THE UNITED STATES TRADE REPRESENTATIVE

Notice of Meeting of the Industry Sector Advisory Committee on Small and Minority Business (ISAC-14)

AGENCY: Office of the United States Trade Representative.

ACTION: Notice of meeting.

SUMMARY: The Industry Sector Advisory Committee on Small and Minority Business (ISAC 14) will hold a meeting on February 23, 1998 from 9:15 a.m. to 3:00 p.m. The meeting will be open to the public from 9:15 a.m. to 12:30 p.m. and closed to the public from 12:30 p.m. to 3:00 p.m.

DATES: The meeting is scheduled on February 23, 1998, unless otherwise notified.

ADDRESSES: The meeting will be held at the Department of Commerce in Room 3884, located at 14th Street and Constitution Avenue, N.W., Washington, D.C., unless otherwise notified.

FOR FURTHER INFORMATION CONTACT:

Millie Sjoberg, Department of Commerce, 14th St. and Constitution Ave., N.W., Washington, D.C. 20230, (202) 482-4792 or Bill Daley, Office of the United States Trade Representative, 600 17th St. N.W., Washington, D.C. 20508, (202) 395-6120.

SUPPLEMENTARY INFORMATION: The ISAC 14 will hold a meeting on February 23, 1998 from 9:15 a.m. to 3:00 p.m. The meeting will include a review and discussion of current issues which influence U.S. trade policy. Pursuant to Section 2155(f)(2) of Title 19 of the United States Code and Executive Order 11846 of March 27, 1975, the Office of the U.S. Trade Representative has determined that part of this meeting will be concerned with matters the disclosure of which would seriously compromise the development by the United States Government of trade policy, priorities, negotiating objectives or bargaining positions with respect to the operations of any trade agreement and other matters arising in connection with the development, implementation and administration of the trade policy of the United States. During the discussion of such matters, the meeting will be closed to the public from 12:30 p.m. to 3:00 p.m. The meeting will be open to

the public and press from 9:15 a.m. to 12:30 p.m. when other trade policy issues will be discussed. Attendance during this part of the meeting is for observation only. Individuals who are not members of the committee will not be invited to comment.

Pate Felts,

Acting Assistant United States Representative, Intergovernmental Affairs and Public Liaison.

[FR Doc. 98-3274 Filed 2-9-98; 8:45 am]

BILLING CODE 3190-01-M

DEPARTMENT OF TRANSPORTATION

Federal Aviation Administration

Revision #2 to the Approved Noise Compatibility Program, San Diego International Airport—Lindbergh Field (SAN), San Diego, CA

AGENCY: Federal Aviation Administration, DOT.

ACTION: Notice.

SUMMARY: The Federal Aviation Administration (FAA) announces that it is reviewing a proposed Revision (#2) to the approved Noise Compatibility Program that was submitted by the San Diego Unified Port District for San Diego International Airport—Lindbergh Field (SAN), San Diego, California, under the provisions of Title I of the Aviation Safety and Noise Abatement Act of 1979 (Pub. L. 96-193) (hereinafter referred to as "the Act") and 14 CFR Part 150. The proposed Revision #1 to the Noise Compatibility Program, therefore review and determination of new maps are not necessary. The proposed Revision #2 consists of sound attenuation of residential homes between the 65 dB and 75 dB CNEL contours.

EFFECTIVE DATE: The effective date of the start of the FAA's review of the revision to the approved Noise Compatibility Program is January 27, 1998. The public comment period ends February 25, 1998. The proposed Revision #2 to the approved Noise Compatibility Program will be approved or disapproved on or before July 28, 1998.

FOR FURTHER INFORMATION CONTACT:

Charles B. Lieber, Airport Planner, Federal Aviation Administration, Western-Pacific Region, P.O. Box 92007, Worldway Postal Center, Los Angeles, California 90009-2007, (310) 725-3614. Comments on the proposed Revision #2 to the Noise Compatibility Program should also be submitted to the above office.

SUPPLEMENTARY INFORMATION: This notice announces that the FAA is reviewing a proposed Revision (#2) to

the approved Noise Compatibility Program for San Diego International Airport—Lindbergh Field which will be approved or disapproved on or before July 28, 1998. This notice also announces the availability of this Revision (#2) for public review and comment.

The FAA has formally received Revision #2 to the approved Noise Compatibility Program for San Diego International Airport—Lindbergh Field, effective on August 13, 1997. It was requested that the FAA review this material and that the noise mitigation measures, to be implemented jointly by the airport and surrounding communities, be approved as a revision to the approved Noise Compatibility Program under Section 104(b) of the Act. On June 5, 1991, the FAA approved the Noise Compatibility Program for the San Diego International Airport. An announcement of FAA's approval of the Noise Compatibility Program was published in the Federal Register on June 19, 1991. On May 11, 1995, the FAA approved Revision #1 to the Noise Compatibility Program. Preliminary review of Revision #2 indicates that it conforms to the requirements for the submittal of Noise Compatibility Programs, but that further review will be necessary prior to approval or disapproval of the revision. The formal review period, limited by law to a maximum of 180 days, will be completed on or before July 28, 1998.

The FAA's detailed evaluation will be conducted under the provisions of 14 CFR Part 150, Section 150.33. The primary considerations in the evaluation process are whether the proposed measures may reduce the level of aviation safety, create an undue burden on interstate or foreign commerce, or be reasonably consistent with obtaining the goal of reducing existing noncompatible land uses and preventing the introduction of additional noncompatible land uses.

Interested persons are invited to comment on the proposed Revision #2 with specific reference to these evaluation factors. All comments, other than those properly addressed to local land use authorities, will be considered by the FAA to the extent practicable. Copies of the Noise Exposure Maps, the approved Noise Compatibility Program, Revision #1 to the Noise Compatibility Program, and proposed Revision (#2) are available for examination at the following locations:

Federal Aviation Administration,
National headquarters, 800
Independence Avenue, SW., Room
617, Washington, DC 20591

Federal Aviation Administration,
Western-Pacific Region AWP-600,
P.O. Box 92007 WPC, Los Angeles,
California 90009-2007

Mrs. Danette B. Lake, Director, Airport
Noise Information, San Diego Unified
Port District, P.O. Box 488, San Diego
California 92112-0488

Questions may be directed to the
individual named above under the
heading, **FOR FURTHER INFORMATION
CONTACT.**

Issued in Hawthorne, California on January
27, 1998.

Herman C. Bliss,
Manager, Airports Division, Western-Pacific
Region, AWP-600.

[FR Doc. 98-3297 Filed 2-9-98; 8:45 am]

BILLING CODE 4910-13-M

DEPARTMENT OF TRANSPORTATION

Federal Aviation Administration

Termination of Environmental Impact Statement at General Mitchell International Airport, Milwaukee, Wisconsin

AGENCY: Federal Aviation
Administration, DOT.

ACTION: Notice of termination.

SUMMARY: The Federal Aviation Administration (FAA) is issuing this notice to advertise to the public that preparation of an Environmental Impact Statement (EIS) for the proposed extension of Runway 7L/25R by 700 ft; the implementation of approved FAR Part 150 Noise Abatement Measures NA-4 and NA-5; the implementation of a modified departure procedure for aircraft departing Runway 19R in lieu of disapproved Noise Abatement Measure NA-7; for updating the airport's Noise Exposure Maps (NEM's); and for evaluation of other cumulative or connected actions at the General Mitchell International Airport (MKE), Milwaukee, Wisconsin has been terminated. The airport has dropped the proposal to pursue the three noise abatement departure procedures and to update the airport's NEM's which were included in the original Notice of Intent issued in the Federal Register on Thursday, August 29, 1996. One project remains, however, to be subject to an environmental review. This remaining project is the proposed 700 ft extension to Runway 7L/25R along with any cumulative or connected actions. The FAA has recently completed its environmental review of this project and has concluded that it can be categorically excluded from the need to

prepare an environmental assessment or environmental impact statement.

FOR FURTHER INFORMATION CONTACT: Mr. Daniel J. Millenacker, Program Manager, Federal Aviation Administration, Airports District Office, 6020 28th Avenue South, Room 102, Minneapolis, Minnesota, 55450-2706. Phone (612) 713-4359.

SUPPLEMENTARY INFORMATION: This notice announces that the FAA, in cooperation with the Wisconsin Department of Transportation and Milwaukee County, Wisconsin, has terminated an EIS for those projects listed above, with the exception of the proposal to lengthen general aviation Runway 7L/25R at MKE by 700 feet to provide a total length of 4,800 ft to accommodate certain general aviation turboprop and commuter category aircraft. The decision to not continue the environmental process for the three noise abatement procedures and the update of MKE's NEM's was made by Milwaukee County, who, as the airport sponsor, decided to withdraw the project. The sponsor's decision was supported by a study which concluded that the noise abatement procedures would not result in significantly beneficial noise relief to communities surrounding the airport. A decision to prepare a categorically exclusion document for the runway extension project was based upon a preliminary environmental analysis which indicated that the 700 ft extension would not result in significant impacts to any of these environmental categories defined under FAA Order 5050.4A.

Questions may be directed to the individual named above under the heading, **FOR FURTHER INFORMATION CONTACT.**

Issued in Minneapolis, Minnesota, January
16, 1998.

Franklin D. Benson,
Manager, Minneapolis Airports District
Office, FAA Great Lakes Region.

[FR Doc. 98-3298 Filed 2-9-98; 8:45 am]

BILLING CODE 4910-13-M

DEPARTMENT OF TRANSPORTATION

Federal Aviation Administration

Notice of Intent to Rule on Application to Impose and Use the Revenue From a Passenger Facility Charge (PFC) at Worcester Regional Airport, Worcester, Massachusetts

AGENCY: Federal Aviation
Administration (FAA), DOT.

ACTION: Notice of intent to rule on
application.

SUMMARY: The FAA proposes to rule and invites public comment on the application to impose and use the revenue from a PFC at Worcester Regional Airport under the provisions of the Aviation Safety and Capacity Expansion Act of 1990 (Title IX of the Omnibus Budget Reconciliation Act of 1990) (Pub. L. 101-508) and Part 158 of the Federal Aviation Regulations (14 CFR Part 158).

DATES: Comments must be received on or before March 12, 1998.

ADDRESSES: Comments on this application may be mailed or delivered in triplicate to the FAA at the following address: Federal Aviation Administration, Airports Division, 12 New England Executive Park, Burlington, Massachusetts 01803.

In addition, one copy of any comments submitted to the FAA must be mailed or delivered to Mr. Eugene B. Conrad, Airport Director for Worcester Regional Airport at the following address: Worcester Regional Airport, 375 Airport Drive, Worcester, Massachusetts 01602.

Air carriers and foreign air carriers may submit copies of written comments previously provided to the City of Worcester under section 158.23 of Part 158.

FOR FURTHER INFORMATION CONTACT:

Priscilla A. Scott, PFC Program Manager, Federal Aviation Administration, Airports Division, 12 New England Executive Park, Burlington, Massachusetts 01803, (781) 238-7614. The application may be reviewed in person at 16 New England Executive Park, Burlington, Massachusetts.

SUPPLEMENTARY INFORMATION: The FAA proposes to rule and invites public comment on the application to impose and use the revenue from a PFC at Worcester Regional Airport under the provisions of the Aviation Safety and Capacity Expansion Act of 1990 (Title IX of the Omnibus Budget Reconciliation Act of 1990) (Public Law 101-508) and Part 158 of the Federal Aviation Regulations (14 CFR Part 158).

On January 13, 1998, the FAA determined that the application to impose and use the revenue from a PFC submitted by the City of Worcester was substantially complete within the requirements of section 158.25 of Part 158. The FAA will approve or disapprove the application, in whole or in part, no later than April 8, 1998.

The following is a brief overview of the application.

*PFC Project #: 98-02-C-00-ORH.
Level of the proposed PFC: \$3.00.*

Proposed charge effective date:

October 1, 1992.

Proposed charge expiration date: May 31, 1997.

Total estimated net PFC revenue: \$393,556.

Brief description of proposed projects: Runway 11/29 Drainage Improvements and Permanent Erosion Control Measures
Purchase Snow Removal Equipment
PFC Professional Services

Class or classes of air carriers which the public agency has requested not be required to collect PFCs: The City of Worcester has not requested any exclusions.

Any person may inspect the application in person at the FAA office listed above under **FOR FURTHER INFORMATION CONTACT**.

In addition, any person may, upon request, inspect the application, notice and other documents germane to the application in person at the Worcester Regional Airport, 375 Airport Drive, Worcester, Massachusetts 01602.

Issued in Burlington, Massachusetts on January 29, 1998.

Vincent A. Scavano,

Manager, Airports Division, New England Region.

[FR Doc. 98-3299 Filed 2-9-98; 8:45 am]

BILLING CODE 4910-13-M

DEPARTMENT OF TRANSPORTATION

National Highway Traffic Safety Administration

Federal Highway Administration

Availability of the Revised Draft Guideline for Minimum Uniform Crash Criteria

AGENCY: National Highway Traffic Safety Administration and the Federal Highway Administration, DOT.

ACTION: Notice of availability.

SUMMARY: This notice announces the availability of Revised Draft Guideline for Minimum Uniform Crash Criteria (MUCC) for public review. The Guideline is a cooperative effort of the Highway Safety Community under the sponsorship of the National Highway Traffic Safety Administration, the Federal Highway Administration, and the National Association of Governors' Highway Safety Representatives. It is intended to meet a recognized need to collect uniform motor traffic vehicle crash data both within a state and across states. Implementation of a final Guideline by the states by will voluntary.

ADDRESSES: Interested parties may obtain a printed copy of the Revised Draft by sending a written request via one of the modes listed below or by downloading it from the MUCC Internet site:

<http://www.nhtsa.dot.gov/people/ncsa/codes/MinData/minstand.html>.

By Mail:

MUCC Guideline, NHTSA, NRD-31, 400 Seventh Street, S.W., Room 6125, Washington, DC 20590

By FAX:

202.366.7078

By E-Mail:

MUCCMAIL@nhtsa.dot.gov

FOR FURTHER INFORMATION CONTACT:

Mr. Dennis E. Utter, National Center for Statistics and Analysis, NHTSA, NRD-31, 400 Seventh Street, S.W., Room 6125, Washington, DC 20590; phone-202.366.531; E-Mail-dutter@nhtsa.dot.gov.

Issued: February 4, 1998.

Patricia Breslin, Ph.D.

Director, National Center for Statistics and Analysis, National Highway Traffic Safety Administration.

Michael Trentacoste,

Director, Office of Highway Safety, Federal Highway Administration.

[FR Doc. 98-3288 Filed 2-9-98; 8:45 am]

BILLING CODE 4910-69-M

DEPARTMENT OF THE TREASURY

Submission for OMB Review; Comment Request

February 3, 1998.

The Department of Treasury has submitted the following public information collection requirement(s) to OMB for review and clearance under the Paperwork Reduction Act of 1995, Public Law 104-13. Copies of the submission(s) may be obtained by calling the Treasury Bureau Clearance Officer listed. Comments regarding this information collection should be addressed to the OMB reviewer listed and to the Treasury Department Clearance Officer, Department of the Treasury, Room 2110, 1425 New York Avenue, NW., Washington, DC 20220.

Financial Management Service (FMS)

OMB Number: 1510-0012.

Form Number: FMS 6314.

Type of Review: Extension.

Title: Annual Financial Statements of Surety Companies—Schedule F.

Description: The information is obtained from Surety and Insurance Companies. It is used to compute the amount of unauthorized reinsurance in determining Treasury Certified

Companies' underwriting limitations which are published in Treasury Circular 570 for use by Federal Bond approving officers.

Respondents: Business or other for-profit.

Estimated Number of Respondents: 451.

Estimated Burden Hours Per Respondent: 48 hours, 45 minutes.

Frequency of Response: Annually.

Estimated Total Reporting Burden: 19,108 hours.

Clearance Officer: Jacqueline R. Perry (301) 344-8577, Financial Management Service, 3361-L 75th Avenue, Landover, MD 20785.

OMB Reviewer: Alexander T. Hunt (202) 395-7860, Office of Management and Budget, Room 10202, New Executive Office Building, Washington, DC 20503.

Lois K. Holland,

Departmental Reports Management Officer.

[FR Doc. 98-3279 Filed 2-9-98; 8:45 am]

BILLING CODE 4810-35-P

DEPARTMENT OF THE TREASURY

Submission to OMB for Review; Comment Request

February 3, 1998.

The Department of Treasury has submitted the following public information collection requirement(s) to OMB for review and clearance under the Paperwork Reduction Act of 1995, Public Law 104-13. Copies of the submission(s) may be obtained by calling the Treasury Bureau Clearance Officer listed. Comments regarding this information collection should be addressed to the OMB reviewer listed and to the Treasury Department Clearance Officer, Department of the Treasury, Room 2110, 1425 New York Avenue, NW., Washington, DC 20220.

Internal Revenue Service (IRS)

OMB Number: 1545-1566.

Notice Number: Notice 97-66.

Type of Review: Extension.

Title: Certain Payments Made Pursuant to a Securities Lending Transaction.

Description: Notice 97-66 modifies final regulations which are effective November 14, 1997. The Notice relaxes the statement requirement with respect to substitute interest payments relating to securities loans and repurchase transactions. It also provides a withholding mechanism to eliminate excessive withholding on multiple payments in a chain of substitute dividend payments.

Respondents: Business or other for-profit.

Estimated Number of Respondents: 377,500.

Estimated Burden Hours Per

Respondent: 10 minutes.

Frequency of Response: Other (once).

Estimated Total Reporting Burden: 61,750 hours.

Clearance Officer: Garrick Shear (202) 622-3869, Internal Revenue Service, Room 5571, 1111 Constitution Avenue, NW., Washington, DC 20224.

OMB Reviewer: Alexander T. Hunt (202) 395-7860, Office of Management and Budget, Room 10226, New Executive Office Building, Washington, DC 20503.

Lois K. Holland,

Departmental Reports Management Officer.

[FR Doc. 98-3280 Filed 2-9-98; 8:45 am]

BILLING CODE 4830-01-P

DEPARTMENT OF THE TREASURY

Submission for OMB Review; Comment Request

January 30, 1998.

The Department of Treasury has submitted the following public information collection requirement(s) to OMB for review and clearance under the Paperwork Reduction Act of 1995, Pub. L. 104-13. Copies of the submission(s) may be obtained by calling the Treasury Bureau Clearance Officer listed. Comments regarding this information collection should be addressed to the OMB reviewer listed and to the Treasury Department Clearance Officer, Department of the Treasury, Room 2110, 1425 New York Avenue, NW., Washington, DC 20220.

Bureau of the Public Debt (PD)

OMB Number: 1535-0062.

Form Number: PD F 2966.

Type of Review: Extension.

Title: Special Bond of Indemnity to the United States.

Description: The form is used by the purchasers of savings bonds in a chain letter scheme to request refund of the purchase price of the bonds.

Respondents: Individuals or households.

Estimated Number of Respondents: 6,000.

Estimated Burden Hours Per Respondent: 8 minutes.

Frequency of Response: On occasion.

Estimated Total Reporting Burden Hours: 665 hours.

OMB Number: 1535-0111.

Form Number: SB 2152 and SB 2153.

Type of Review: Extension.

Title: Authorization for Purchase and Request for Change United States Savings Bonds.

Description: These forms are used to authorize employers to allot funds from

employee's pay for the purchase of Savings Bonds.

Respondents: Individuals or households.

Estimated Number of Respondents: 1,600,000.

Estimated Burden Hours Per Respondent: 1 minute.

Frequency of Response: On occasion.

Estimated Total Reporting Burden Hours: 33,333 hours.

OMB Number: 1535-0127.

Form Number: None.

Type of Review: Extension.

Title: Offering of United States Mortgage Guaranty Insurance Company Tax and Loss Bonds.

Description: Regulations governing the issue, reissue, and redemption of United States Mortgage Guaranty Insurance Company tax and loss bonds.

Respondents: Business or other for-profit.

Estimated Number of Respondents: 37.

Estimated Burden Hours Per Respondent: 15 minutes.

Frequency of Response: On occasion.

Estimated Total Reporting Burden Hours: 20 hours.

Clearance Officer: Vicki S. Thorpe (304) 480-6553, Bureau of the Public Debt, 200 Third Street, Parkersburg, West VA 26106-1328.

OMB Reviewer: Alexander T. Hunt (202) 395-7860, Office of Management and Budget, Room 10226, New Executive Office Building, Washington, DC 20503.

Lois K. Holland,

Departmental Reports, Management Officer.

[FR Doc. 98-3281 Filed 2-9-98; 8:45 am]

BILLING CODE 4810-40-P

UNITED STATES INFORMATION AGENCY

Culturally Significant Objects Imported for Exhibition Determinations

Notice is hereby given of the following determinations: Pursuant to the authority vested in me by the Act of October 19, 1965 (79 Stat. 985, 22 U.S.C. 2459), Executive Order 12047 of March 27, 1978 (43 FR 13359, March 29, 1978), and Delegation Order No. 85-5 of June 27, 1985 (50 FR 27393, July 2, 1985), I hereby determine that the objects to be included in the exhibit "Conversion by Candlelight: The Four Magdalens by Georges de la Tour" (see list ¹), imported

¹ A copy of this list may be obtained by contacting Mr. Paul W. Manning, Assistant General Counsel, at 202/619-5997, and the address is Room 700, U.S. Information Agency, 301 Fourth Street, S.W., Washington, D.C. 20547-0001.

from abroad for the temporary exhibition without profit within the United States, are of cultural significance. These objects are imported pursuant to loan agreements with the foreign lenders. I also determine that the exhibition or display of the listed exhibit objects at The Metropolitan Museum of Art, New York, New York, from on or about February 9, 1998, to on or about March 15, 1998, is in the national interest. Public Notice of this determination is ordered to be published in the **Federal Register**.

Dated: February 3, 1998.

Les Jin,

General Counsel.

[FR Doc. 98-3336 Filed 2-9-98; 8:45 am]

BILLING CODE 8230-01-M

Corrections

Federal Register

Vol. 63, No. 27

Tuesday, February 10, 1998

This section of the FEDERAL REGISTER contains editorial corrections of previously published Presidential, Rule, Proposed Rule, and Notice documents. These corrections are prepared by the Office of the Federal Register. Agency prepared corrections are issued as signed documents and appear in the appropriate document categories elsewhere in the issue.

DEPARTMENT OF THE INTERIOR**Office of Surface Mining Reclamation and Enforcement****30 CFR Part 924**

[SPATS No. MS-012-FOR]

Mississippi Regulatory Program*Correction*

In rule document 98-532 beginning on page 1342 in the issue of Friday, January 9, 1998, make the following corrections:

(1) On page 1345, in the first column, starting in the thirteenth line remove "However, the Director finds that the proposed definition is not inconsistent with the Federal definition."

(2) On the same page, in the second column, in the first full paragraph, seven lines from the bottom "utility of publicly" should read "utility or publicly".

(3) On page 1348, in the third column, in the first full paragraph, in the twelfth line "plant" should read "plan".

(4) On page 1352, in the third column, in the first full paragraph, six lines from the bottom "are non inconsistent" should read "are not inconsistent".

(5) On page 1353, in the first column, in the second full paragraph, three lines from the bottom "from other requirement" should read "from the requirement".

BILLING CODE 1505-01-D

Federal Register

Tuesday
February 10, 1998

Part II

Department of Housing and Urban Development

24 CFR Part 200

Use of Materials Bulletins Used in HUD
Building Products Standards and
Certification Program; Proposed Rule

**DEPARTMENT OF HOUSING AND
URBAN DEVELOPMENT**
24 CFR Part 200

[Docket No. FR-4265-P-01]

RIN 2502-AH02

**Use of Materials Bulletins Used in the
HUD Building Products Standards and
Certification Program**
AGENCY: Office of the Assistant
Secretary for Housing-Federal Housing
Commissioner, HUD.

ACTION: Proposed rule.

SUMMARY: This proposed rule would adopt a number of Use of Materials Bulletins (UM's) and references related to national voluntary consensus standards in accordance with OMB Circular 119A. It also supplements the HUD Building Product Standards and Certification Program by requiring that additional information be included on the label, tag, or mark that each manufacturer affixes to the certified product. The labeling of these products is in the public interest because it will allow consumers to readily identify those products that comply with existing voluntary consensus standards. In addition, the rule would eliminate the need for manufacturers of these building products to seek HUD acceptance for individual products. HUD will now accept them on a generic basis for use in houses covered under HUD mortgage insurance programs, thus streamlining Departmental requirements. This proposed rule also specifies the frequency with which products should be tested in order to be acceptable to HUD. Section (c)(1) of 24 CFR 200.935 would be modified to accept organizations that comply with International Standards Organization (ISO) standard Guide 65-96 "General Requirements for Bodies Operating Product Certification Systems" as an alternative to the acceptance qualifications specified in this section. Also, section (d)(3) of 24 CFR 200.935 would be modified to allow the use of ISO standard Guide 25-90 "General Requirements for the Competency of Calibration and Testing Laboratories", as a voluntary guideline for accrediting laboratories.

DATES: *Comment due date:* April 13, 1998.

ADDRESSES: Interested persons are invited to submit comments regarding this rule to the Rules Docket Clerk, Office of the General Counsel, Room 10276, Department of Housing & Urban Development, 451 Seventh Street, SW., Washington, DC 20410-0500.

Communication should refer to the above docket number and title. A copy of each communication submitted will be available for public inspection and copying between 7:30 am and 5:30 pm weekdays at the above address. Facsimile comments will not be accepted.

FOR FURTHER INFORMATION CONTACT: David R. Williamson, Director, Office of Consumer and Regulatory Affairs, Department of Housing and Urban Development, 451 Seventh Street SW., Room 9156, Washington, DC 20410-8000; telephone: voice (202) 708-6423; TTY, (202) 708-4594 (these are not toll free numbers.)

SUPPLEMENTARY INFORMATION: HUD's Building Product Standards and Certification Programs (BPSCP), authorized by section 521 of the National Housing Act, 12 U.S.C. 1735e, provide a sound basis for determining the acceptability of materials and products for use in properties with HUD-insured mortgages. Under the BPSCP, materials and products are determined to be acceptable through the Department's issuance of Materials Releases and Use of Materials Bulletins. The Department issues Materials Releases to individual manufacturers for the acceptance of specific new or innovative building products where there are no existing standards for such products. Use of Materials Bulletins are issued by the Department for the acceptance of products on a generic or class basis, making it unnecessary for individual manufacturers to continue applying for approval of similar products, and making the approval process overall much less cumbersome.

Materials Releases are periodically renewed or revised, for a fee, by the Department. In cases where there are many manufacturers of similar new products, or standards developed that cover these products, the Department cancels the Materials Releases and refers to the new standard, and a certification program, in a Use of Materials Bulletin.

Use of Materials Bulletins are issued in the public interest, to provide HUD standards that establish minimum acceptable qualities for certain materials and products to be used in properties subject to mortgages insured by the Department. In accordance with 24 CFR 200.935, UM's are also used in third-party labeling and certification programs to assure that the building products used in HUD programs meet the appropriate national voluntary standards.

With the promulgation of a Use of Materials Bulletin, individual manufacturers no longer have to pay a

fee to the Department for the maintenance of their Materials Releases, and the Department no longer has the administrative burden of renewing or revising the individual Materials Releases. For these reasons, the Department anticipates increasing its reliance on Use of Materials Bulletins to accept new or innovative building products.

This proposed rule would promulgate the following Use of Materials Bulletins:

- UM 25e Application and Fastening Schedule at § 200.958
- UM 40d Plywood and Other Wood-Based Structural-Use Panels at § 200.944
- UM 44e Carpet and Carpet With Attached Cushions at § 200.945
- UM 48a Pressure Treated Lumber and Plywood at § 200.960
- UM 52b Wood Flush Doors and Primary Entrance Doors at § 200.961
- UM 71b Polystyrene Foam Insulation Board at § 200.947
- UM 72b Carpet Cushion at § 200.948
- UM 73b Plastic Plumbing Fixtures at § 200.937
- UM 82b Sealed Insulating Glass Units at § 200.940
- UM 84a Solid Fuel Type Room Heaters and Fireplace Stoves at § 200.936
- UM 89a Steel Insulated Exterior Door Systems at § 200.949
- UM 100a Solar Water Heating Systems at § 200.950
- UM 104 Kitchen Cabinets, Plastic Sinks, and Solid Surface Kitchen Countertops at § 200.956
- UM 105 Elastomeric Joint Sealants at § 200.951
- UM 110 Sprayed Polyurethane Foam Roof Insulation at § 200.953

UMs 40d, 44e, 72b, 73b, 105, and 110 have previously been issued for public comment as parts of a proposed rule published on May 19, 1997 (62 FR 27486). The Department has updated the standards referenced in the proposed rule along with these UMs, and is reissuing them for public comment before adopting them in a final rule.

The third party certification program for "Kitchen Cabinets, Plastic Sinks, and Solid Surface Kitchen Countertops" has been informally accepted by the Department, and would be designated as new Bulletin UM 104 under the procedures of 24 CFR 200.935.

UM 44e, Carpet and Carpet With Attached Cushions, would be implemented at § 200.945, which currently cites UM 44d. Section 200.942, which also cites 44d, would be removed and reserved.

In addition, section (c)(1) of 24 CFR 200.935 would be modified to accept organizations that comply with the International Standards Organization (ISO) standard Guide 65-96, "General Requirements for Bodies Operating

Product Certification Systems," as an alternative to the acceptance criteria specified in this section. Also, section (d)(3) of 24 CFR 200.935 is being modified to allow the use of International Standards Organization (ISO) standard Guide 25-90, "General Requirements for the Competency of Calibration and Testing Laboratories," as a voluntary guideline for accrediting laboratories.

The Department has evaluated the updated technical standards prepared by national standards organizations, and plans to adopt these standards by incorporating them in the UMs by reference. The UMs adopted would also augment the labeling requirements of 24 CFR 200.935(d)(6).

Copies of UM's are available for public inspection during regular business hours in the Office of Consumer and Regulatory Affairs, Department of Housing and Urban Development, Room 9156, 451 Seventh Street, SW, Washington, DC. 20410-8000, and in the Office of the Rules Docket Clerk, Office of the General Counsel, Room 10276, at the Department of Housing and Urban

Development, Washington, DC. 20410-0500. This proposed rule permits public comment prior to the issuance of the subject Use of Materials Bulletins.

Findings and Certifications

Paperwork Reduction Act

The proposed information collection requirements contained at §§ 200.936, 200.937, 200.940, 200.944, 200.945, 200.947, 200.948, 200.949, 200.950, 200.951, 200.953, 200.956, 200.958, 200.960, and 200.961 of this rule have been submitted to the Office of Management and Budget (OMB) for review, under section 3507(d) of the Paperwork Reduction Act of 1995 (44 U.S.C. Chapter 35).

(a) In accordance with 5 CFR 1320.5(a)(1)(iv), the Department is setting forth the following concerning the proposed collection of information:

(1) Title of the information collection proposal:

Department of Housing and Urban Development—Minimum Property Standards, Use of Materials Bulletins for HUD Building Products Standards and Certification Programs.

(2) Summary of the collection of information:

The labeling requirements inform the public and particularly the building and mortgage industries that the covered building products meet the minimum standard to qualify for HUD insurance.

(3) Description of the need for the information and its proposed use:

Labeling building products makes them easily identifiable as acceptable for purposes of obtaining HUD insurance.

(4) Description of the likely respondents, including the estimated number of likely respondents, and proposed frequency of response to the collection of information:

Respondents are standard-setting organizations who issue validating labels to product manufacturers. The labels are a convenient way of indicating the products meet the Minimum Property Standards necessary to qualify for HUD insurance.

(5) Estimate of the total reporting and recordkeeping burden that will result from the collection of information:

REPORTING BURDEN

Number of respondents	Freq. of response	Est. avg. response time (hours)	Est. annual burden (hrs.)
20	20	1	400
Total Reporting Burden			400 hours

(b) In accordance with 5 CFR 1320.8(d)(1), the Department is soliciting comments from members of the public and affected agencies concerning the proposed collection of information to:

(1) Evaluate whether the proposed collection of information is necessary for the proper performance of the functions of the agency, including whether the information will have practical utility;

(2) Evaluate the accuracy of the agency's estimate of the burden of the proposed collection of information;

(3) Enhance the quality, utility, and clarity of the information to be collected; and

(4) Minimize the burden of the collection of information on those who are to respond; including through the use of appropriate automated collection techniques or other forms of information technology, e.g., permitting electronic submission of responses.

Interested persons are invited to submit comments regarding the information collection requirements in

this proposal. Under the provisions of 5 CFR part 1320, OMB is required to make a decision concerning this collection of information between 30 and 60 days after today's publication date. Therefore, a comment on the information collection requirements is best assured of having its full effect if OMB receives the comment within 30 days of today's publication. This time frame does not affect the deadline for comments to the agency on the proposed rule, however. Comments must refer to the proposal by name and docket number (FR-4265) and must be sent to: Joseph F. Lackey, Jr., HUD Desk Officer, Office of Management and Budget, New Executive Office Building, Washington, DC 20503.

Unfunded Mandates Reform Act

Title II of the Unfunded Mandates Reform Act of 1995 establishes requirements for Federal agencies to assess the effects of their regulatory actions on State, local, and tribal governments and the private sector.

This proposed rule does not impose any Federal mandates on any State, local or tribal governments or the private sector within the meaning of the Unfunded Mandates Reform Act of 1995.

Environmental Impact

A Finding of No Significant Impact with respect to the environment has been made in accordance with HUD regulations in 24 CFR part 50, which implement section 102(2)(C) of the National Environmental Policy Act of 1969, 42 U.S.C. 4332. The Finding of No Significant Impact is available for public inspection and copying between 7:30 am and 5:30 pm weekdays in the Office of the Rules Docket Clerk, Room 10276, 451 Seventh Street, SW, Washington, DC 20410-0500.

Impact on Small Entities

The Secretary, in accordance with the Regulatory Flexibility Act (U.S.C. 605(b)) has reviewed and approved this proposed rule, and in so doing certifies that this rule will not have a significant economic impact on a substantial

number of small entities. These Use of Materials Bulletins adopt standards that are nationally recognized throughout the affected industry and will not create a burden on manufacturers currently meeting the standards. The proposed rule will have no adverse or disproportionate economic impact on small businesses.

Federalism Impact

The General Counsel has determined, as the Designated Official for HUD under section 6(a) of Executive Order 12612, Federalism, that this rule does not have federalism implications concerning the division of local, State, and federal responsibilities. The rule only proposes to adopt standards that are already nationally recognized throughout the affected industry.

Incorporation by Reference

These standards have been approved by the Director of the Federal Register for incorporation by reference in accordance with 5 U.S.C. 552(a) and 1 CFR 51. Copies of the standards may be obtained from the American National Standards Institute, Inc. (ANSI), 11 West 42nd Street, New York, NY 10036, the American Society for Testing and Materials (ASTM), 100 Barr Harbor Drive, West Conshohocken, PA 19428, or from the organizations specifically mentioned in the referenced section.

List of Subjects in 24 CFR Part 200

Administrative practice and procedure, Claims, Equal employment opportunity, Fair housing, Home improvement, Housing standards, Incorporation by reference, Lead poisoning, Loan programs—housing and community development, Minimum property standards, Mortgage insurance, Organization and functions (Government agencies), Penalties, Reporting and recordkeeping requirements, Social security, Unemployment compensation, Wages.

Accordingly, 24 CFR part 200 is proposed to be amended as follows:

PART 200—INTRODUCTION

1. The authority citation for 24 CFR part 200 continues to read as follows:

Authority: 12 U.S.C. 1701 through 1715z-18; 42 U.S.C. 3535(d).

2. In § 200.935, paragraph (c)(1), and paragraph (d)(3) are revised, and a new paragraph (f) is added, to read as follows:

§ 200.935 Administrator qualifications and procedures for HUD building products certification programs.

* * * * *

(c) *Administration qualifications and application procedures.* (1) *Qualifications.* Each program administrator shall be capable of conducting a certification program with respect to organization, staff, and facilities, and have a reputation for adhering to high ethical standards. To be considered acceptable for conducting a certification program, each administrator shall, in the alternative, comply with International Standards Organization (ISO) standard Guide 65-96, "General Requirements for Bodies Operating Product Certification Systems," or with the following qualifications:

* * * * *

(d) * * *
(3) *Laboratory approval.* The administrator shall review the laboratories that apply for participation in this program on the basis of the procedures described in paragraph (e) of this section. A list of approved laboratories shall be maintained by the administrator. When the certification program allows the use of the administrator's testing laboratories, the laboratories shall be reviewed by a qualified party acceptable to HUD. When HUD requires the use of accredited laboratories for specific products, the International Standards Organization (ISO) standard Guide 25-90 "General Requirements for the Competency of Calibration and Testing Laboratories", may be used as the basis for accrediting laboratories.

* * * * *

(f) The standards cited in this section have been approved by the Director of the Federal Register for incorporation by reference in accordance with 5 U.S.C. 552(a) and 1 CFR part 51. The ISO standards are available from the American National Standards Institute (ANSI), 11 West 42nd Street, New York, NY 10036.

3. Section 200.936 is revised to read as follows:

§ 200.936 Supplementary specific requirements under the HUD building product standards and certification program for solid fuel type room heaters and fireplace stoves.

(a) *Applicable standards.* (1) All solid fuel type heaters and fireplace stoves shall be designed, manufactured, and tested in compliance with the following standards of the American National Standards Institute (ANSI), which are incorporated by reference:

- (i) ANSI/UL 737-95, Standard for Fireplace Stoves;
- (ii) ANSI/UL 1482-88, Standard for Solid Fuel Type Room Heaters.

(2) These standards have been approved by the Director of the Federal Register for incorporation by reference in accordance with 5 U.S.C. 552(a) and 1 CFR part 51. They are available from the American National Standards Institute (ANSI), 11 West 42nd Street, New York, NY 10036.

(b) *Labeling.* Under the procedures set forth in 24 CFR 200.935(d)(6) concerning labeling of a product, the administrator's validation mark and the manufacturer's certification of compliance with the applicable standards are required to be on the certification label issued by the administrator to the manufacturer. Each fireplace stove and solid fuel type room heater shall be marked as conforming to UM 84a. The label shall be located on each stove or room heater so that it is available for inspection. The label shall include the manufacturer's name, plant location, model number, and type of fuel to be used.

(c) *Periodic tests and quality assurance inspections.* Under the procedures concerning periodic tests and quality assurance inspections, the frequency of testing for a product shall be described in the specific building product certification program. In the case of fireplace stoves and solid fuel type room heaters, testing and inspection shall be conducted as follows:

- (1) At least every four years, the administrator shall visit the manufacturer's facility to select a sample of each certified fireplace stove and solid fuel type room heater for testing in an accredited laboratory.
- (2) The administrator shall also review the quality assurance procedures once a year to assure that they are being followed by the manufacturer.

4. Section 200.937 is revised to read as follows:

§ 200.937 Supplementary specific requirements under the HUD building product standards and certification program for plastic plumbing fixtures.

(a) *Applicable standards.* (1) All plastic plumbing fixtures shall be designed, manufactured, and tested in compliance with the following American National Standards Institute (ANSI) standards, which are incorporated by reference:

- (i) ANSI Z 124.1-95 Plastic Bathtub Units;
- (ii) ANSI Z 124.2-95 Plastic Shower Receptors and Shower Stalls;
- (iii) ANSI Z 124.3-95 Plastic Lavatories;
- (iv) ANSI Z 124.4-96 Plastic Water Closets, Bowls, & Tanks; and
- (v) ANSI Z 124.6-90 Plastic Sinks.

(2) These standards have been approved by the Director of the Federal Register for incorporation by reference in accordance with 5 U.S.C. 552(a) and 1 CFR part 51. They are available from the American National Standards Institute, Inc., 11 West 42nd Street, New York, NY 10036.

(b) *Labeling.* Under the procedures set forth in 24 CFR 200.935(d)(6) concerning labeling of a product, the administrator's validation mark and the manufacturer's certification of compliance with the applicable standards are required to be on the certification label issued by the administrator to the manufacturer. Each plastic plumbing fixture shall be marked as conforming to UM 73b. The label shall be located on each plastic plumbing fixture so that it is available for inspection. The label shall include the manufacturer's name and plant location.

(c) *Periodic tests and quality assurance inspections.* Under the procedures concerning periodic tests and quality assurance inspections, the frequency of testing for a product shall be described in the specific building product certification program. In the case of plastic plumbing fixtures, testing and inspection shall be conducted as follows:

(1) At least every year, the administrator shall visit the manufacturer's facility to select a sample of each certified plastic plumbing fixture for testing in a laboratory accredited by the National Voluntary Laboratory Accreditation Program (NVLAP) of the U.S. Department of Commerce.

(2) The administrator shall also review the quality assurance procedures once a year to assure that they are being followed by the manufacturer.

5. Section 200.940 is revised to read as follows:

§ 200.940 Supplementary specific requirements under the HUD building product standards and certification program for sealed insulating glass units.

(a) *Applicable standards.* (1) All sealed insulating glass units shall be designed, manufactured, and tested in compliance with the following standard of the American Society for Testing & Materials (ASTM), ASTM E 774-97, Standard Specification for the Classification of the Durability of Sealed Insulating Glass Units.

(2) This standard has been approved by the Director of the Federal Register for incorporation by reference in accordance with 5 U.S.C. 552(a) and 1 CFR part 51. The standard is available from the American Society for Testing &

Materials (ASTM), 100 Barr Harbor Drive, West Conshohocken, PA 19428.

(b) *Labeling.* Under the procedures set forth in 24 CFR 200.935(d)(6) concerning labeling of a product, the administrator's mark, and the manufacturer's certification of compliance with the applicable standard are required to be on the certification label issued by the administrator to the manufacturer. Each sealed insulating glass unit shall be marked as conforming to UM 82b. The label shall be located on each sealed insulating glass unit so that it is available for inspection. The label shall include the manufacturer's name, plant location, and type.

(c) *Periodic tests and quality assurance inspections.* Under the procedures concerning periodic tests and quality assurance inspections, the frequency of testing for a product shall be described in the specific building product certification program. In the case of sealed insulating glass units, testing and inspection shall be as follows:

(1) At least every year, the administrator shall visit the manufacturer's facility to select a sample of the maximum size commercially available for testing in a laboratory approved by the administrator.

(2) The administrator shall also review the quality assurance procedures every six months to assure that they are being followed by the manufacturer.

§ 200.942 [Removed and Reserved]

6. Section 200.942 is removed and reserved.

7. Section 200.944 is revised to read as follows:

§ 200.944 Supplementary specific requirements under the HUD building product standards and certification program for plywood and other wood-based structural-use panels.

(a) *Applicable standards.* (1) All plywood prescriptively designed, manufactured, and tested shall be in compliance with the U.S. Department of Commerce Voluntary Product Standard PS 1-95. Plywood panels not meeting the grade requirements of PS 1-95 and all composite and non-veneer structural-use panels, shall comply with the "Performance Standards and Policies for Structural-Use Panels-94" (APA Standard PRP 108-94 or TECO Standard PRP 133-94).

(2) These standards have been approved by the Director of the Federal Register for incorporation by reference in accordance with 5 U.S.C. 552(a) and 1 CFR part 51. They are available from

the U.S. Department of Commerce, NIST, Gaithersburg, MD 20899; APA-The Engineered Wood Association, 7011 South 19th St., Tacoma, WA 98411; TECO/PFS Inc., 2402 Daniels Street, Madison, WI. 53704; American Society for Testing and Materials (ASTM), 100 Barr Harbor Drive, West Conshohocken, PA 19428.

(b) *Labeling.* Under the procedures set forth in 24 CFR 200.935(d)(6) concerning labeling of a product, the administrator's validation mark and the manufacturer's certification of compliance with the applicable standards are required to be on the certification label issued by the administrator to the manufacturer. All plywood panels made to PS 1-95 prescriptive or performance standards shall be marked as complying to PS 1-95. All plywood products not meeting the requirements of PS 1-95 and all composite and non-veneer structural-use panels that comply with APA PRP 108-94 or TECO PRP 133-94, shall be marked as complying with UM 40d. The label shall be located on each panel so that it is available for inspection. The label shall include the manufacturer's name and mill number.

(c) *Periodic tests and quality assurance.* Under the procedures concerning periodic tests and quality assurance inspections, the frequency of testing for a product shall be described in the specific building product certification program. In the case of plywood and other wood-based structural-use panels, testing and inspection shall be conducted as follows:

(1) At least three times a year, the administrator shall visit the manufacturer's facility to select 10 panels of each certified product for testing in a laboratory accredited by the National Voluntary Laboratory Accreditation Program (NVLAP) of the U.S. Department of Commerce.

(2) The administrator shall also review the quality assurance procedures three times a year to assure that they are being followed by the manufacturer.

8. Section 200.945 is revised to read as follows:

§ 200.945 Supplementary specific requirements under the HUD building product standards and certification program for carpet and carpet with attached cushions.

(a) *Applicable standards.* (1) All carpets and carpets with attached cushions shall be designed, manufactured, and tested in compliance with the following standards:

- (i) ASTM D297-93 Standard Test Method for Rubber Products-Chemical Analysis;
- (ii) ASTM D5848-95 Test Method for Mass per Unit Area of Pile Floor Coverings;
- (iii) ASTM D3936-90 Test Method for Delamination of Secondary Backing of Pile Coverings;
- (iv) ASTM D2646-96 Test Methods for Backing Fabric Characteristics of Pile Yarn Floor Coverings;
- (v) AATCC 16E-93 Test Method for Colorfastness to Light-Xenon;
- (vi) AATCC 165-93 Test for Crocking;

(2) These standards have been approved by the Director of the Federal Register for incorporation by reference in accordance with 5 U.S.C. 552(a) and 1 CFR part 51. They are available from:

- (i) American Society for Testing and Materials (ASTM), 100 Barr Harbor Drive, West Conshohocken, PA 19428;
- (ii) American Association of Textile Chemists and Colorists (AATCC), P.O. Box 12215, Research Triangle Park, NC 27709.

(b) *Labeling*. Under the procedures set forth in 24 CFR 200.935(d)(6) concerning labeling of a product, the administrator's validation mark and the manufacturer's certification of compliance with the applicable standards are required to be on the certification label issued by the administrator to the manufacturer. Each carpet shall be marked at intervals of at least 6 feet and no less than 1 foot from the edge, in compliance with UM 44e. The label shall include the manufacturer's name, plant location, and statement of compliance with UM 44e.

(c) *Periodic tests and quality assurance inspections*. Under the procedures set forth in 24 CFR 200.935(d)(8) concerning periodic tests and quality assurance inspections, the frequency of testing for a product shall be described in the specific building product certification program. In the case of carpet and carpet with attached cushion, testing and inspection shall be conducted as follows:

(1) Two samples of each certified quality shall be taken every six months from the manufacturer and one sample annually from the public marketplace for testing in a laboratory accredited by the National Voluntary Laboratory Accreditation Program (NVLAP) of the U.S. Department of Commerce.

(2) The administrator shall also review the quality procedures twice a year to assure that they are being followed by the manufacturer.

(d) *Cut pile polypropylene carpet*. Provisions for cut pile polypropylene are included under UM 44e.

9. Section 200.947 is revised to read as follows:

§ 200.947 Supplementary specific requirements under the HUD building product standards and certification program for polystyrene foam insulation board.

(a) *Applicable standards*. (1) All polystyrene foam insulation board shall be designed, manufactured, and tested in compliance with the American Society for Testing & Materials (ASTM) standard C 578-95, "Standard Specification for Rigid Cellular Polystyrene Thermal Insulation".

(2) This standard has been approved by the Director of the Federal Register for incorporation by reference in accordance with 5 U.S.C. 552(a) and 1 CFR part 51. The standard is available from the American Society for Testing and Materials (ASTM), 100 Barr Harbor Drive, West Conshohocken, PA 19428.

(b) *Labeling*. Under the procedures set forth in 24 CFR 200.935(d)(6) concerning labeling of a product, the administrator's validation mark and the manufacturer's certification of compliance with the applicable standard are required to be on the certification label issued by the administrator to the manufacturer. Each polystyrene foam insulation board shall be marked as conforming to UM 71b. The label shall be located on each polystyrene foam insulation board so that it is available for inspection. The label shall include the manufacturer's name, plant location, and type.

(c) *Periodic tests and quality assurance inspections*. Under the procedures concerning periodic tests and quality assurance inspections, the frequency of testing for a product shall be described in the specific building product certification program. In the case of polystyrene foam insulating board, testing and inspection shall be conducted as follows:

(1) At least every six months, the administrator shall visit the manufacturer's facility to select a sample for testing in an accredited laboratory.

(2) The administrator shall also review the quality assurance procedures every six months to assure that they are being followed by the manufacturer.

10. Section 200.948 is revised to read as follows:

§ 200.948 Supplementary specific requirements under the HUD building product standards and certification program for carpet cushion.

(a) *Applicable standards*. (1) All carpet cushion shall be designed, manufactured, and tested in compliance with the following standards:

- (i) ASTM D3574-95 Test Method for Flexible Cellular Materials;
- (ii) ASTM D297-93 Standard Test Method for Rubber Products Chemical Analysis;
- (iii) ASTM D629-95 Test Methods for Quantitative Analysis of Textiles;
- (iv) ASTM D1667-90 Specification for Flexible Cellular Materials;
- (v) ASTM D2646-96 Test Method for Backing Fabric Characteristics of Pile Yarn Floor Coverings;
- (vi) ASTM D3696-90 Test Method for Delamination of Secondary Backing of Pile Coverings.

(2) These standards have been approved by the Director of the Federal Register for incorporation by reference in accordance with 5 U.S.C. 552(a) and 1 CFR part 51. They are available from the American Society for Testing and Materials (ASTM), 100 Barr Harbor Drive, West Conshohocken, PA 19428.

(b) *Labeling*. Under the procedures set forth in 24 CFR 200.935(d)(6) concerning labeling of a product, the administrator's validation mark and the manufacturer's certification of compliance with the applicable standards are required to be on the certification label issued by the administrator to the manufacturer. Each carpet cushion shall be marked as to type and class, and as conforming to UM 72b.

(c) *Periodic tests and quality assurance*. Under the procedures set forth in 200.935(d)(8), testing and inspection shall be conducted as follows:

(1) At least twice a year, the administrator shall visit the manufacturer's facility to select a sample of each certified carpet cushion for testing by a laboratory approved by the administrator.

(2) The administrator shall review the quality assurance procedures every six months to assure that they are being followed by the manufacturer.

11. Section 200.949 is revised to read as follows:

§ 200.949 Supplementary specific requirements under the HUD building product standards and certification program for steel insulated exterior door systems.

(a) *Applicable standards*. (1) All steel insulated exterior door systems shall be designed, manufactured, and tested in compliance with the following American Society for Testing & Materials (ASTM) and American National Standards Institute (ANSI) standards:

- (i) ASTM A 591/A 591M-89 (1994), Standard Specification for Steel Sheet Steel, Electrolytic Zinc-Coated for Light Coating Mass Applications;

(ii) ANSI/ISDI 100-90, Door Size Dimensional Standard and Assembly Tolerances for Insulated Steel Door Systems;

(iii) ANSI/ISDI 101-83 (1989), Air Infiltration Performance Standard for Insulated Steel Door Systems;

(iv) ANSI/ISDI 102-93, Installation Standard for Insulated Steel Door Systems;

(v) ANSI/ISDI 104-93, Water Penetration Performance Standard for Insulated Steel Door Systems;

(vi) ANSI A224.1-90, Test Procedure and Acceptance Criteria for Prime Painted Steel Surfaces for Steel Doors and Frames;

(vii) ASTM F 476-84 (1996), Standard Test Methods for Security of Swinging Door Assemblies"

(2) These standards have been approved by the Director of the Federal Register for incorporation by reference in accordance with 5 U.S.C. 552(a) and 1 CFR part 51. The ASTM standard is available from the American Society for Testing & Materials (ASTM), 100 Barr Harbor Drive, West Conshohocken, PA 19428. The ANSI/ISDI standards are available from the American National Standards Institute (ANSI), 11 West 42nd Street, New York, NY 10036.

(b) *Labeling.* Under the procedures set forth in 24 CFR 200.935(d)(6) concerning labeling of a product, the administrator's validation mark and the manufacturer's certification of compliance with the applicable standards are required to be on the certification label issued by the administrator to the manufacturer. Each insulated exterior steel door system shall be marked as conforming to UM 89a. The label shall be located on each insulated exterior steel door system so that it is available for inspection. The label shall include the manufacturer's name and plant location.

(c) *Periodic tests and quality assurance inspections.* Under the procedures concerning periodic tests and quality assurance inspections, the frequency of testing for a product shall be described in the specific building product certification program. In the case of insulated exterior steel door systems, testing and inspection shall be conducted as follows:

(1) At least every four years, the administrator shall visit the manufacturer's facility to select a sample in a laboratory approved by the administrator.

(2) The administrator shall also review the quality assurance procedures once a year to assure that they are being followed by the manufacturer.

12. Section 200.950 is revised to read as follows:

§ 200.950 Supplementary specific requirements under the HUD building product standards and certification program for solar water heating systems.

(a) *Applicable standard.* (1) All solar water heating systems shall be designed, manufactured, and tested in compliance with the Solar Rating & Certification Corporation (SRCC) Standard OG 300-97, Operating Guidelines & Minimum Standards for Certifying Solar Water Heating Systems: An Optional SWH System Certification and Rating Program. Section 10 of the SRCC standard has been omitted because it was considered proprietary, since it describes an administrative program specifically carried out by SRCC.

(2) This standard has been approved by the Director of the Federal Register for incorporation by reference in accordance with 5 U.S.C. 552(a) and 1 CFR part 51. The standard is available from the Solar Rating and Certification Corporation (SRCC), 777 North Capital Street, NE., Suite 805, Washington, DC 20002.

(b) *Labeling.* Under the procedures set forth in 24 CFR 200.935(d)(6) concerning labeling of a product, the administrator's validation mark and the manufacturer's certification of compliance with the applicable standard are required to be on the certification label issued by the administrator to the manufacturer. Each solar water heating system shall be marked as conforming to UM 100a. The label shall be located on each solar water heating system so that it is available for inspection. The label shall include the manufacturer's name and plant location.

(c) *Periodic tests and quality assurance inspections.* Under the procedures concerning periodic tests and quality assurance inspections, the frequency of testing for a product shall be described in the specific building product certification program. In the case of solar water heating systems, testing and inspection shall be conducted as follows:

(1) At least every four years, the administrator shall visit the manufacturer's facility to select a sample of each certified solar water heating system for testing in a laboratory approved by an administrator.

(2) The administrator shall also review the quality assurance procedures every two years to assure that they are being followed by the manufacturer.

(d) *Warranty.* The manufacturer shall provide, at no cost, a full five-year warranty against defects in material or workmanship, on the absorber plate, cooling passages, and the collector (excluding any glass), running from the

date of installation of the solar water heating system. The warranty also shall include the full costs of field inspection, parts, and labor required to remedy the defects, and will include the cost of replacement at the site if required. The warranty is not required to cover defects resulting from exposure to harmful materials, fire, flood, lightning, hurricane, tornado, hailstorms, earthquakes, or other acts of God, vandalism, explosions, harmful chemicals or other fluids, fumes, or vapors. This exclusion will apply to the operation of the collector under excessive pressures or excessive flow rates, misuse, abuse, negligence, accidents, alterations, falling objects or other causes beyond the control of the manufacturer. Following the initial five years, the manufacturer shall provide a limited no-cost five year warranty for the collector parts on a pro rata allowance basis.

13. A new § 200.951 is added to read as follows:

§ 200.951 Supplementary specific requirements under the HUD building product standard and certification program for elastomeric joint sealants.

(a) *Applicable standards.* (1) All exterior elastomeric joint sealants shall be designed, manufactured, and tested in compliance with the following American Society for Testing and Materials standards:

(i) ASTM C920-95 Standard Specification for Elastomeric Joint Sealants, Class 25 and Class 12½, except that 2500 hours are required using test methods ASTM G26-96 Standard Practice for Operating Light-Exposure Apparatus (Xenon-Arc Type) With and Without Water for Exposure of Nonmetallic Materials or ASTM G53-96 Standard Practice for Operating Light- and Water-Exposure Apparatus (Fluorescent UV-Condensation Type) for Exposure of Nonmetallic Materials. It should be noted that this standard alone does not provide sufficient information for all appropriate uses of a product, and also that the user must comply with the manufacturer's installation recommendations.

(ii) ASTM C1193-95 Standard Guide for the Use of Joint Elastomeric Sealants.

(2) These standards have been approved by the Director of the Federal Register for incorporation by reference in accordance with 5 U.S.C. 552(a) and 1 CFR part 51. They are available from the American Society for Testing and Materials (ASTM), 100 Barr Harbor Drive, West Conshohocken, PA 19428.

(b) *Labeling.* Under the procedures set forth in 24 CFR 200.935(d)(6) concerning labeling of a product, the

administrator's validation mark and the manufacturer's certification of compliance with the applicable standards are required to be on the certification label issued by the administrator to the manufacturer. Each container of elastomeric joint sealant shall include the sealant's type, grade, class, and use, and the manufacturer's name, plant location and statement of compliance with UM 105.

(c) *Periodic tests and quality assurance inspections.* Under the procedures set forth in 24 CFR 200.935(d)(8) concerning periodic tests and quality assurance inspections, the frequency of testing for a product shall be described in the specific building product certification program. In the case of elastomeric joint sealants, testing and inspection shall be conducted as follows:

(1) At least once every year, the administrator shall visit the manufacturer's facility to select a sample for testing in a laboratory accredited by the National Voluntary Laboratory Accreditation Program (NVLAP) of the U.S. Department of Commerce.

(2) The administrator shall also review the quality assurance procedures once a year to assure that they are being followed by the manufacturer.

14. A new § 200.953 is added to read as follows:

§ 200.953 Supplementary specific requirements under the HUD building product standards and certification program for sprayed polyurethane foam roof insulation.

(a) *Applicable standards.* (1) All sprayed polyurethane foam for roof insulation shall be designed, manufactured, and tested in compliance with ASTM C1029-96 Standard Specification for Spray Applied Rigid Cellular Polyurethane Thermal Insulation. The foam shall be installed in accordance with ASTM D5469-93 Standard Guide for Application of New Spray-Applied Polyurethane Foam and Coated Roofing Systems, and designed in accordance with the Society of the Plastics Industry (SPI) standard PFCD AY 104-94 Spray Polyurethane Foam Systems for New and Remedial Roofing.

(2) These standards have been approved by the Director of the Federal Register for incorporation by reference in accordance with 5 U.S.C. 552(a) and 1 CFR part 51. They are available from the American National Standards Institute, Inc., 11 West 42nd Street, New York, NY 10036, or the Society of the Plastics Industry (SPI), 1801 K Street, NW, Suite 600K, Washington, D.C., 20006.

(b) *Labeling.* Under the procedures set forth in 24 CFR 200.935(d)(6) concerning labeling of a product, the administrator's validation mark and the manufacturer's certification of compliance with the applicable standard are required to be on the certification label issued by the administrator to the manufacturer. Each container or package of sprayed polyurethane foam roof insulation material shall be marked as conforming to UM 110. The label shall include the manufacturer's name and plant location.

(c) *Periodic tests and quality assurance inspections.* Under the procedures set forth in 24 CFR 200.935(d)(8) concerning periodic tests and quality assurance inspections, the frequency of testing for a product shall be described in the specific building product certification program. In the case of sprayed polyurethane foam for roof insulation, testing and inspection shall be conducted as follows:

(1) At least twice a year, the administrator shall visit the manufacturer's facility to select a sample for testing in an approved laboratory with the applicable standard.

(2) The administrator shall also review the quality assurance procedures twice a year to assure that they are being followed by the manufacturer.

15. A new § 200.956 is added to read as follows:

§ 200.956 Supplementary specific requirements under the HUD building product standards and certification program for kitchen cabinets, plastic sinks, and solid surface kitchen countertops.

(a) *Applicable standards.* (1) All kitchen cabinets, plastic sinks, and solid surface kitchen countertops shall be designed, manufactured, and tested in accordance with the following American National Standards Institute (ANSI) standards:

(i) ANSI/KCMA A161.1-95, Performance and Construction Standard for Kitchen and Vanity Cabinets;

(ii) ANSI Z124.6-90, Plastic Sinks;

(iii) ANSI/ICPA-SS-1-97, Performance Standard for Solid Surface Materials.

(2) These standards have been approved by the Director of the Federal Register for incorporation by reference in accordance with 5 U.S.C. 552(a) and 1 CFR part 51. The ANSI standards are available from the American National Standards Institute (ANSI), 11 West 42nd Street, New York, New York 10036. The ANSI/ICPA standard is available from the International Cast Polymer Association (ICPA), 8201 Greensboro Drive, Suite 300, McLean, VA 22102.

(b) *Labeling.* Under the procedures set forth in 24 CFR 200.935(d)(6) concerning labeling of a product, the administrator's validation mark and the manufacturer's certification of compliance with the applicable standards are required to be on the certification label issued by the administrator to the manufacturer. Each kitchen cabinet, plastic sink, and solid surface kitchen countertop shall be marked as conforming to UM 104. The label shall include the manufacturer's name and plant location.

(c) *Periodic tests and quality assurance inspections.* Under the procedures concerning periodic tests and quality assurance inspections, the frequency of testing for a product shall be described in the specific building product certification program. In the case of kitchen cabinets, plastic sinks, and solid surface kitchen countertops, testing and inspection shall be conducted as follows:

(1) At least every year, the administrator shall visit the manufacturer's facility to select a sample of each kitchen cabinet, plastic sink, or solid surface kitchen countertop for testing in a laboratory approved by the administrator.

(2) The administrator shall also review the quality assurance procedures once a year to assure that they are being followed by the manufacturer.

16. A new § 200.958 is added to read as follows:

§ 200.958 Supplementary specific requirements under the HUD building product standards program for application and fastening schedule.

(a) *Applicable standards.* (1) All fasteners shall be designed, manufactured, and tested in compliance with the International Staple, Nail, & Tool Association (ISANTA) standard SNT 112-97, International Power Staples, Nails & Allied Fasteners For All Types of Building Construction.

(2) This standard has been approved by the Director of the Federal Register for incorporation by reference in accordance with 5 U.S.C. 552(a) and 1 CFR part 51. It is available from the International Staple, Nail, & Tool Association (ISANTA), 512 West Burlington Avenue, LaGrange, IL 60525.

(b) There are no labeling or certification requirements under UM 25e, Application and Fastening Schedule.

17. A new § 200.960 is added to read as follows:

§ 200.960 Supplementary specific requirements under the HUD building product standards and certification program for pressure treated lumber and plywood.

(a) *Applicable standards.* (1) All pressure treated lumber and plywood shall be designed, manufactured, and tested in compliance with the following American Wood Preservers Association (AWPA) standards:

(i) AWPA C1-96, All Timber Products—Preservative Treatment by Pressure Processes;

(ii) AWPA C2-96, Lumber, Timbers, Bridge Ties, and Mine Ties—Preservative Treatment by Pressure Processes;

(iii) AWPA C9-96, Plywood—Preservative Treatment by Pressure Processes;

(iv) AWPA C15-96, Wood for Commercial-Residential Construction—Preservative Treatment by Pressure Processes;

(v) AWPA C22-96, Lumber and Plywood for Permanent Wood Foundations—Preservative Treatment by Pressure Processes;

(vi) AWPA C28-95, Standard for Preservative Treatment of Structural Glued Laminated Members and Laminations Before Gluing of Southern Pine, Pacific Coast Douglas Fir, Hemfir, and Western Hemlock by Pressure Processes;

(vii) AWPA C31-95, Lumber Used Out of Contact With the Ground and Continuously Protected from Liquid Water—Treatment by Pressure Processes.

(2) These standards have been approved by the Director of the Federal Register for incorporation by reference in accordance with 5 U.S.C. 552(a) and 1 CFR part 51. They are available from the American Wood Preservers Association (AWPA), 32346 Fall Creek Highway, Suite 190, Granbury, Texas 76049.

(b) *Labeling.* Under the procedures set forth in 24 CFR 200.935(d)(6) concerning labeling of a product, the administrator's validation mark and the

manufacturer's certification of compliance with the applicable standards are required to be on the certification label issued by the administrator to the manufacturer. Each piece of pressure treated lumber and plywood shall be marked as conforming to UM 48a or the referenced AWPA standard. The label shall include the manufacturer's name, plant location, the preservative used, the preservative retention time, the year of treatment if required by the AWPA standard, and the exposure category (e.g. Above Ground, Ground Contact).

(c) *Periodic tests and quality assurance inspections.* Under the procedures concerning periodic tests and quality assurance inspections, the frequency of testing for a product shall be described in the specific building product certification program. In the case of pressure treated lumber and plywood, testing and inspection shall be as follows:

(1) At least every six months, the administrator shall visit the manufacturer's facility to select a sample for testing in a laboratory approved by the administrator.

(2) The administrator shall also review the quality assurance procedures every six months to assure that they are being followed by the manufacturer.

18. A new § 200.961 is added to read as follows:

§ 200.961 Supplementary specific requirements under the HUD building product standards and certification program for wood flush doors and primary entrance doors.

(a) *Applicable standards.* (1) All architectural wood flush door systems and primary entrance doors shall be designed, manufactured, and tested in compliance with the following National Window & Door Association (NWDA) standards:

(i) ANSI/NWWDA I.S. 1A-97, Architectural Wood Flush Doors;

(ii) ANSI/NWWDA I.S. 9-88, Wood Primary Entrance Doors;

(2) These standards have been approved by the Director of the Federal Register for incorporation by reference in accordance with 5 U.S.C. 552(a) and 1 CFR part 51. They are available from the American National Standards Institute (ANSI), 11 West 42nd Street, New York, NY 10036.

(b) *Labeling.* Under the procedures set forth in 24 CFR 200.935(d)(6) concerning labeling of a product, the administrator's mark and the manufacturer's certification of compliance with the applicable standards are required to be on the certification label issued by the administrator to the manufacturer. Each architectural wood flush door system and primary entrance door system shall be marked as conforming to UM 52b. The label shall be located on each door so that it is available for inspection. The label shall include the manufacturer's name and plant location.

(c) *Periodic tests and quality assurance inspections.* Under the procedures concerning periodic tests and quality assurance inspections, the frequency of testing for a product shall be described in the specific building product certification program. In the case of wood doors, testing and inspection shall be conducted as follows:

(1) At least every four years, the administrator shall visit the manufacturer's facility to select a sample of each certified wood door for testing in a laboratory approved by the administrator.

(2) The administrator shall also review the quality assurance procedures once a year to assure that they are being followed by the manufacturer.

Dated: January 5, 1998.

Nicolas P. Retsinas,

Assistant Secretary for Housing-Federal Housing Commissioner.

[FR Doc. 98-3236 Filed 2-9-98; 8:45 am]

BILLING CODE 4210-27-P



Federal Register

Tuesday
February 10, 1998

Part III

Department of Transportation

Federal Aviation Administration

14 CFR Part 21
Primary Category Seaplanes; Direct Final
Rule

DEPARTMENT OF TRANSPORTATION**Federal Aviation Administration****14 CFR Part 21**

[Docket No. 27641; Amendment No. 21-75]

RIN 2120-AG39

Primary Category Seaplanes**AGENCY:** Federal Aviation Administration, DOT.**ACTION:** Direct final rule; confirmation of effective date.**SUMMARY:** This action confirms the effective date of a rule, published on November 25, 1997, which established a maximum weight limit of 3,375 pounds

for seaplanes that are proposed for type certification in the primary category.

EFFECTIVE DATE: February 23, 1998.**FOR FURTHER INFORMATION CONTACT:**

Brian A. Yanez, Certification Procedures Branch (AIR-110), Aircraft Certification Service, Federal Aviation Administration, 800 Independence Avenue, SW., Washington, DC 20591, telephone (202) 267-9588.

SUPPLEMENTARY INFORMATION: The FAA published the direct final rule with a request for comments in the *Federal Register* on November 25, 1997 (62 FR 62805). The FAA uses the direct final rulemaking procedure for a non-controversial rule where the FAA believes there will be no adverse public

comment. The direct final rule advised the public that no adverse comments were anticipated, and that unless a written adverse comment, or a written notice of intent to submit such an adverse comment, were received within the comment period, the regulation would become effective on February 23, 1998. No adverse comments were received, and thus this document confirms that the final rule will become effective on that date.

Issued in Washington, DC, on February 3, 1998.

Donald P. Byrne,*Assistant Chief Counsel for Regulations.*

[FR Doc. 98-3292 Filed 2-9-98; 8:45 am]

BILLING CODE 4910-13-M

Federal Register

**Tuesday
February 10, 1998**

Part IV

Department of Agriculture

**Cooperative State Research, Education,
and Extension Service, Risk Management
Agency, Federal Crop Insurance
Corporation**

Request for Proposals; Notice

DEPARTMENT OF AGRICULTURE

Cooperative State Research,
Education, and Extension Service

Risk Management Agency

Federal Crop Insurance Corporation

Request for Proposals

AGENCIES: Cooperative State Research, Education, and Extension Service (CSREES), Risk Management Agency (RMA), and Federal Crop Insurance Corporation (FCIC), USDA.

ACTION: Announcement of availability of grant funds and request for proposals for Agricultural Risk Management Education.

SUMMARY: CSREES and RMA, administering this program for FCIC, in consultation with the Risk Management Education Steering Committee, is soliciting proposals for a Risk Management Education Program under section 516 of the Federal Crop Insurance Act and under a delegation of authority memorandum from the FCIC to the Administrator of CSREES. Projects are solicited in the following areas: 1. The delivery of risk management education programs to producers and related agribusiness operators in the U.S. agricultural sector (program delivery); 2. The development of agricultural risk management educational curricula and materials (curriculum and materials); and 3. Supporting research that leads to improved risk management strategies and decision aids for agricultural producers or that improves access to risk management information (supportive research).

This notice sets out the objectives for these projects, the eligibility criteria for projects and applicants, the application procedures and instructions, and the project selection process and evaluation criteria. To obtain application forms, contact the CSREES Proposal Services Unit, Office of Extramural Programs, USDA/CSREES at (202) 401-5048; e-mail: psb@reeusda.gov. When contacting the Proposal Services Unit, please indicate that you are requesting forms for the Risk Management Education Program.

DATES: Applications must be received on or before April 13, 1998. Proposals received after April 13, 1998 will not be considered for funding.

FOR FURTHER INFORMATION CONTACT: Craig Witt, Risk Management Agency, U.S. Department of Agriculture, Stop 0805, 1400 Independence Avenue, S.W., Washington, D.C. 20250-0805; Voice: (202) 690-2957; Fax: (202) 690-2095;

Internet: cwitt@wdc.fas.usda.gov; or Donald A. West, Cooperative State Research, Education, and Extension Service, U.S. Department of Agriculture, Stop 2212, 1400 Independence Avenue, S.W., Washington, D.C. 20250-2212; Voice: (202) 720-5633; Fax: (202) 690-2522; Internet: dwest@reeusda.gov.

Table of Contents

Part I—General Information

- A. Legislative Authority
- B. Definitions
- C. Eligibility

Part II—Program Description

- A. Purpose of the Program
- B. Available Funds and Award Limitations
- C. Indirect Costs
- D. Scope of Program
- E. Program Delivery
- F. Curriculum and Materials
- G. Supportive Research

Part III—Preparation of a Proposal

- A. Program Application Materials
- B. Content of a Proposal

Part IV—Submission of a Proposal

- A. What to Submit
- B. When and Where to Submit

Part V—Selection Process and Evaluation Criteria

- A. Selection Process
- B. Evaluation Criteria

Part VI—Supplementary Information

- A. Access to Peer Review Information
- B. Grant Awards
- C. Use of Funds; Changes
- D. Other Federal Statutes and Regulations that Apply
- E. Confidential Aspects of Proposals and Awards
- F. Evaluation of Program
- G. Regulatory Information

Part I—General Information

A. Legislative Authority

Sections 506(l) of the Federal Crop Insurance Act, 7 U.S.C. 1506, provides FCIC with the authority to carry out programs intended to provide education in the management of risks inherent in the production of agricultural commodities. Consequently, FCIC is providing assistance to stimulate programs which help agricultural producers understand the effective use of insurance protection programs and other related risk management tools which lead to their improved financial stability.

FCIC funds this competitive grants program under its authority in section 516 of the Federal Crop Insurance Act, 7 U.S.C. 1516, to fund research and development of risk management programs for insurance protection and related issues. FCIC and CSREES have entered into an interagency agreement under the Economy act, 31 U.S.C. 1535,

and FCIC has delegated the necessary authority for CSREES to administer this program for FCIC.

B. Definitions

For the purpose of making awards under this program, the following definitions are applicable:

Administrator means the Administrator of the Cooperative State Research, Education, and Extension Service (CSREES) and any other officer or employee of the Department of Agriculture to whom the authority involved may be delegated.

Agricultural Risk Management means the informed use of tools and strategies by farmers, ranchers, and agribusiness firms to deal with the risks encountered when producing and marketing agricultural products. The insurance protection programs area, including those related risks encountered in the production, marketing, financial, legal, and human resource(s) aspects of agricultural operations, is the primary thrust of this RFP.

Authorized Departmental Officer means the Secretary or any employee of the Department who has the authority to issue or modify grant instruments on behalf of the Secretary.

Authorized Organizational Representative means the official designated by the president or chief executive officers of the applicant organization who has the authority to commit the resources of the organization.

Budget Period means the interval of time (usually 12 months) into which the project period is divided for budgetary and reporting purposes.

Department or USDA means the United States Department of Agriculture.

Grant means the award by the Administrator of CSREES or his designee of funds to an eligible entity whose proposal has been selected under this RFP.

Grantee means the organization designated in the grant award document as the responsible legal entity to which a grant is awarded.

Insurance (Risk) Protection Programs mean programs relating to crop insurance and agriculture-related risks and losses.

Manager means the Manager of the Federal Crop Insurance Corporation (FCIC).

Peer Review Panel means a group of experts qualified by training and experience in particular fields designated by the Risk Management Education Steering Committee to evaluate eligible proposals in those fields submitted under this RFP.

Prior approval means written, prior consent by an authorized departmental officer as defined above.

Producers and Related Agribusiness Operators mean individuals, companies, or corporations engaged in the business of agriculture or in the business of supplying agriculture with products or services.

Project Director means the person designated by the grantee in the grant application and approved by the Secretary who is responsible for the direction and management of the project.

Project means the insurance protection program or related risk management education activity for which a grant has been requested.

Project period means the specific dates, as stated in the award document and modifications thereto, if any, during which Federal sponsorship begins and ends.

Public and private sector delivery points mean the direct contacts between a person delivering the RME program and the producer (e.g., a lender or insurance agent discussing risk management with a producer).

RME Steering Committee means the Risk Management Education Steering Committee, consisting of representatives from RMA, CSREES, and the Commodity Futures Trading Commission, formed by these agencies in an April 1997 Memorandum of Understanding.

Request for Proposals (RFP) means an invitation to submit projects for consideration for funding under this program.

Secretary means the Secretary of Agriculture and any other officer or employee of the Department of Agriculture to whom the authority involved may be delegated.

C. Eligibility

Except where otherwise prohibited by law, proposals are invited from all colleges and universities, other research institutions, Federal, State, and local agencies, nonprofit and for-profit private organizations or corporations, and individuals, with strong encouragement to minority organizations, which have a demonstrated capability to conduct risk management education delivery, curricula development or supportive research programs. Projects which represent, involve, or foster partnerships between two or more eligible entities are encouraged.

To compete for a grant, an entity must submit a completed application before the announced deadline. To be eligible, an entity must have: (a) The capacity

and professional expertise to deliver educational programs, prepare curricula and materials, or conduct research in agricultural risk management; (b) adequate knowledge of insurance protection programs and related areas in agricultural production, marketing, financial, legal and human resource practices; (c) competency to implement a project, provide fiscal accountability and oversight, and prepare status reports and project documentation; and (d) a demonstrated willingness to share information with researchers, educators, and the public.

Although an applicant may be eligible to compete for an award based on its status as an eligible entity, other factors may exclude an applicant from receiving Federal assistance under this program (e.g., debarment and suspension, a determination of non-responsibility based on the information submitted).

Part II—Program Description

A. Purpose of the Program

Recent events have placed greater responsibility on U.S. producers to manage the risks of their operations. Recent changes brought about by the Federal Agriculture Improvement and Reform Act of 1996, Pub. L. No. 104-127, increased global competition and price variation, changes in the structure of some agricultural segments, and the adoption of new technologies have all contributed to a more risky environment for U.S. farmers and ranchers. The need to manage risks in this new environment is so compelling that it has prompted new efforts targeting increased risk management education.

Many farm and ranch operators do not have the training to develop effective risk management strategies involving insurance protection and related techniques for their businesses. Moreover, the risks in production, marketing, finance, legal, and human resources are increasingly interconnected. Consequently, these risks demand comprehensive strategies for their management. In seeking profit opportunities in the new risk environment, producers and the agricultural community can benefit from increased risk management education, increased access to risk management information, and new decision aids.

Proposals are requested for the purpose of stimulating the research and development of education in the risks covered by insurance protection programs, including the related areas of production, marketing, finance, legal, and human resource(s). Specifically, these programs should recognize the

relationships between risk areas. They should also be part of a substantial effort to reach all segments of U.S. agricultural producers by increasing their awareness of both traditional and new risk management tools.

Proposals are invited for competitive awards under the Risk Management Education Program for fiscal year (FY) 1998. The purpose of these awards is to provide U.S. agricultural producers with the knowledge, skills, and tools needed to make better-informed risk management decisions. Projects should incorporate one or more of the following areas: (1) Deliver risk management training to U.S. farmers, ranchers, and related agribusinesses; (2) develop and distribute risk management educational curricula and materials; and (3) support research that leads to improved risk management strategies, information, or decision aids for producers. This grants program is funded by the FCIC and administered by CSREES.

B. Available Funds and Award Limitations

For FY 1998, approximately \$3 million is available for risk management education and supportive research projects. The total of all awards will not exceed \$3 million for FY 1998. Proposals will be awarded on a fiscal year basis with a one-year duration for projects focused on educational program delivery and curricula development and up to two years for those focused on supportive research.

Federal funding for each successful proposal will not exceed \$250,000. Proposed budgets are subject to negotiation, but the Federal share will not exceed \$250,000.

C. Indirect Costs

If requested, indirect costs must be justified and may not exceed the current rate negotiated with the cognizant Federal negotiating agency. If no rate has been negotiated, a reasonable dollar amount in lieu of indirect costs may be requested, which will be subject to approval by USDA. Due to the nature of the projects to be funded under this program, applicants are encouraged to request rates that are lower than an applicant's approved negotiated research or instructional rate. Applications from colleges and universities that are not submitted through an Office of Sponsored Programs (or equivalent thereto) must provide a statement in the budget narrative verifying that the indirect costs requested are in accordance with institutional policies.

D. Scope of Program

Risk management education projects funded by this RFP are intended to reach either U.S. agricultural producers directly or agribusinesses that interact with U.S. producers. These projects must be directed to (a) Program delivery; (b) the development of curriculum and materials; and/or (c) supportive research and decision aids. Projects which address more than one of these areas are encouraged. Also encouraged are projects which form or foster private and public partnerships, are likely to become self-supporting, and are innovative. All projects must contain explicit information indicating how results from the project will be measured, evaluated, and reported. The indicators used to measure results of the project should be clear and objective and focus on the anticipated impacts of risk management education or resulting behavior of U.S. agricultural producers, to the extent possible.

E. Program Delivery

Program delivery is providing instruction and materials directly to farmers and ranchers or training third party educators who have the opportunity and ability to reach farmers and ranchers with risk management education. A successful proposal in this area will include the use of strong organizational skills to reach the farmers and ranchers in a specific region or who use similar production practices. Proposals should show how public or private sector (or both) delivery points will be used to reach producers. Moreover, proposals should be mindful of the private sector's competitive motivations and the potential conflicts of interest in providing risk management education. Proposals which use innovative educational techniques to deliver risk management education are encouraged.

F. Curriculum and Materials

Educational curricula and materials are printed, electronically based, or multi-media items which can be used in program delivery. Proposals should offer materials which address important risk management topics, are easy to use, and effectively communicate the risk management message. Projects should produce teaching devices which can be readily understood and easily adopted by program deliverers. Those proposals which address topics and issues not covered in the body of existing risk management education materials are encouraged. Also encouraged are proposals which deal with the linkages

among different kinds of risk and their management.

G. Supportive Research

Supportive research is adaptive or applied research which results in improved educational programming, practical tools, techniques, strategies, or decision aids. Applied research on the unmet risk management needs of crop and livestock producers is encouraged. Producers should be able to use these results in making better risk management decisions. Proposals should also focus on producing results which will be readily understood by producers or by trainers when used in program delivery. Proposals which include innovative approaches are encouraged.

Part III—Preparation of a Proposal

A. Program Application Materials

Program application materials will be made available to eligible entities upon request. These materials include information on the purpose of the program, how the program will be conducted, the required contents of a proposal, and the forms needed to prepare and submit grant applications.

To obtain application forms, please contact the Proposal Services Unit; Office of Extramural Programs; USDA/CSREES at (202) 401-5048. When calling Proposal Services please indicate that you are requesting forms for the Risk Management Education Program. Application materials also may be requested via Internet by sending a message with your name, mailing address (not e-mail) and telephone number to psb@reeusda.gov. The request should indicate that you wish to receive a copy of the application materials for the FY 1998 Risk Management Education Program. Materials will then be mailed to you (not e-mailed).

B. Content of a Proposal

After you have received the application materials, you can complete your application as follows:

1. Cover Page

Complete the "Application for Funding" Form in its entirety.

a. Note that providing a Social Security Number is voluntary, but is an integral part of the CSREES information system and will assist in the processing of the proposal.

b. One copy of the "Application for Funding" form must contain the pen-and-ink signatures of the project director and authorized organizational representative for the applicant organization.

c. Note that by signing the "Application for Funding" form the applicant is providing the required certifications set forth in 7 CFR Part 3017, as amended, regarding Debarment and Suspension and Drug-Free Workplace, and 7 CFR Part 3018, regarding Lobbying. The certification forms are included in this application package for informational purposes only. It is not necessary to submit the forms to USDA.

2. Table of Contents

For ease in locating information, each proposal must contain a detailed table of contents immediately after the proposal cover page. The Table of Contents should include page numbers for each component of the proposal. Pagination should begin immediately following the Table of Contents.

3. Project Summary

The proposal must contain a concise project summary on a separate page. This page must include the title of the project and the names of the project director and the applicant organization, followed by a project summary of 250 words or less. The project summary should describe the overall goals and relevance of the project. It should also contain a listing of all organizations involved in the project. The Project Summary should immediately follow the Table of Contents.

4. Project Narrative

The Project Narrative must be prepared on only one side of each page using standard size (8½" x 11"; 21.6 cm x 27.9 cm) white paper, one-inch margins, typed or word processed using no type smaller than 10 point font regardless of whether it is single or double-spaced. The project narrative shall not exceed 10 pages. It must state and then answer each of the following six questions:

(a) What risk management education activity or supportive research project is being proposed? Explain the type of project, the direct or ultimate beneficiaries of the project, and which areas of risk will be covered. The project must be directed to either program delivery, the development of curricula and materials, or supportive research. More than one of these three activities can be included in one project. Identify and describe the insurance protection and related areas of risk (production, marketing, financial, legal, or human resources) which will be included in the project. Describe the methodology to be used, the procedures to be followed, and the time line for their completion. Include a description of any innovative

techniques used in the project to advance risk management education.

(b) At what audience(s) is the project directed? Provide a description of the U.S. agricultural production sector(s) for which the project is intended. Describe the geographical area, demographic profile, and perceived risk management needs of the proposed beneficiaries of the project. Indicate reasons why these risk management education needs are not being met with existing programs.

(c) What are the goals of the project? Describe the goals of the project and the procedures to be followed in meeting them. Indicate how the project will make a positive measurable impact on producer's knowledge of agricultural risks and their ability to cope with these risks. Indicate, also, how the impact of the project will be measured and how results will be reported. Ensure that indicators used to measure the results of the project are relevant and as objective as possible.

(d) What partnering opportunities will be created through the project? Identify the private and public organizations that will participate in the project. Identify any additional organizations which may become involved or have a positive influence on risk management education as a result of the project.

(e) How can the project become self-sustaining? For program delivery proposals, or components of proposals, indicate how the project can become self-sustaining in the absence of further outside funding. Specify mechanisms such as user fees or product sales that could be used.

(f) How does the project assist in the effort to provide simple and practical risk management tools to producers? Describe the ways in which the project activities will communicate clearly and simply with producers. Indicate the ways in which this project will result in the producers receiving practical, user-friendly materials or tools for risk management.

5. Key Personnel

Identify the primary project director, the co-project manager(s), and other key personnel committed to this project. Summarize the relevant experience of key project personnel that will enable them to successfully complete the project. Include brief vitae which provide enough information so that proposal reviewers can make an informed judgment as to their capabilities and experience. An organizational chart for the project should be provided if available.

6. Budget

Budget Form: Prepare the budget form in accordance with instructions provided with the form. Projects selected for program delivery or curricula and materials will be funded for up to one year. Projects selected for supportive research will be funded for up to two years. A budget form is required for each year of requested support. In addition, a summary budget is required detailing the requested total support for the overall project period, if more than one year. The budget form may be reproduced as needed by applicants. Funds may be requested under any of the categories listed on the form, provided that the item or service for which support is requested is allowable under authorizing legislation, applicable Federal cost principles, these program guidelines, and can be justified as necessary for the successful conduct of the proposed project. Requested expenditures for equipment should not represent more than 10 percent of the budget total.

7. Current and Pending Support

All proposals must list any other current public or private support (including in-house support) to which key personnel identified in the proposal have committed portions of their time, whether or not salary support for person(s) involved is included in the budget. Analogous information must be provided for any pending proposals that are being considered by, or that will be submitted in the near future to, other possible sponsors, including other USDA programs or agencies. Concurrent submission of identical or similar proposals to other possible sponsors will not prejudice proposal review or evaluation for this purpose. However, a proposal that duplicates or overlaps substantially with a proposal already reviewed and funded (or that will be funded) by another organization or agency will not be funded under this program. The application material includes Form CSREES-663 which is suitable for listing current and pending support.

8. Compliance With the National Environmental Policy Act (NEPA)

Environmental data for any proposed project is to be provided to CSREES so that CSREES may determine whether any further action is needed. In some cases, however, the preparation of environmental data may not be required. Certain categories of actions are excluded from the requirements of NEPA.

In order for CSREES to determine whether any further action is needed with respect to NEPA, pertinent information regarding the possible environmental impacts of a particular project is necessary; therefore, Form CSREES-1234, "NEPA Exclusions Form," must be included in the proposal indicating whether the applicant is of the opinion that the project falls within a categorical exclusion and the reasons therefor. If it is the applicant's opinion that the proposed project falls within the categorical exclusions, the specific exclusion must be identified. Form CSREES-1234 and supporting documentation should be placed after the Form CSREES-661, "Application for Funding," in the proposal.

Even though a project may fall within the categorical exclusions, CSREES may determine that an Environmental Assessment or an Environmental Impact Statement is necessary for an activity, if substantial controversy on environmental grounds exists or if other extraordinary conditions or circumstances are present which may cause such activity to have a significant environmental effect.

Part IV—Submission of a Proposal

A. What to Submit

An original and 14 copies of each proposal must be submitted. Each copy must be stapled in the upper left-hand corner (DO NOT BIND). All copies of a proposal must be submitted in one package.

B. Where and When to Submit

Proposals must be received by close of business on April 13, 1998. A proposal's postmark date is not a factor in whether an application is timely received. The applicant assumes the risk of any unforeseen delays in proposal delivery. Proposals sent by First Class mail must be sent to the following address: Risk Management Education Program, c/o Proposal Services Unit, Office of Extramural Programs, USDA/CSREES, Stop 2245, 1400 Independence Ave., S.W., Washington, D.C. 20250-2245; Telephone: (202) 401-5048.

Note: Hand-delivered proposals or those delivered by overnight express service should be brought to the following address: Risk Management Education Program, c/o Proposal Services Unit, Office of Extramural Programs; USDA/CSREES; Room 303, Aerospace Center; 901 D Street, S.W.; Washington, DC 20024. The telephone number is (202) 401-5048.

C. Acknowledgment of Proposals

The receipt of all proposals will be acknowledged in writing and this

acknowledgment will contain an identifying proposal number. Once a proposal has been assigned an identification number, the number should be referred to in future correspondence.

Part V—Selection Process and Evaluation Criteria

A. Selection Process

Each proposal will be evaluated in a three-part process. First, each proposal will be screened by CSREES to ensure it meets the requirements as set forth in this solicitation. Second, proposals that meet these requirements will be technically evaluated by an expert peer review panel(s) selected by and using procedures approved by the RME Steering Committee. Evaluation criteria are set forth below. Each proposal will be judged on its own merit. Third, after the peer review panel(s) submits its recommendations to the RME Steering Committee, the Administrator of CSREES or his designee will make the final award decisions in consultation with the RME Steering Committee.

B. Evaluation Criteria

The peer review panel(s) will evaluate all proposals using the following criteria:

1. Program Need 20 Points

How well does the proposal identify an existing risk management education need for insurance protection or a related area that can be filled by the project? How pressing is the need identified in the project? Does the project address topics, issues, or needs of producer groups not covered in existing risk management educational programs?

2. Professional Expertise: 20 Points

Which skills, talents, and professional experiences do the applicants bring to the project? What does the track record of the applicants indicate about the likely delivery and quality of the project results?

3. Partnering: 10 Points

To what extent does the project involve organizations or groups with the capacity to conduct risk management education or supportive research? How will this partnering enhance the effort to educate agricultural producers?

4. Feasibility: 10 Points

How realistic are the project's stated goals and objectives? What is the probability that the project will reach its objectives, given the skills and prior performance of the applicant?

5. Simplicity and Practicality: 10 Points

How well does the proposal recognize the need for simplicity and practicality in risk management education for U.S. farmers and ranchers? How well will farmers and ranchers be able to understand and use the results of the project?

6. Measurability of Results: 10 Points

Are the goals and objectives of the project well-defined? Have provisions been made to measure the impact of the project? How objective and reliable are the proposed measurements and what provisions are made for reporting results on a timely basis?

7. Innovation: 10 Points

Does the proposal offer innovative approaches, procedures or solutions to the problems addressed? For example, how well does the project use new technology to accomplish its objectives? Does the project address linkages among various sources of risk and management strategies to deal with them?

8. Sustainability: 10 Points

For projects focused on program delivery, how long will the positive effects of the project likely continue? Are mechanisms set in motion by this project that assure that the delivery activity will continue in the absence of outside funding?

Part VI—Supplementary Information

A. Access to Peer Review Information

After final decisions have been announced, CSREES will, upon request, inform the project director of the basis for its decision on a proposal. Copies of summary reviews, not including the identity of the reviewers, will be made available to respective project directors.

B. Grant Awards

1. General

Within the limit of funds available for such purpose, the awarding official of CSREES shall make grants to eligible applicants whose proposals are judged most meritorious under the technical evaluation criteria and procedures set forth in this request for proposals. The date specified by the Administrator as the effective date of the grant shall be no later than September 30 of the Federal fiscal year in which the project is approved for support and funds are appropriated for such purpose, unless otherwise permitted by law. It should be noted that the project need not be initiated on the grant effective date, but as soon thereafter as practicable so that project goals may be attained within the funded project period. All funds granted

and administered by CSREES under this request for proposals shall be expended solely for the purpose for which the funds are granted in accordance with the approved application and budget, the terms and conditions of the award, the applicable Federal cost principles, and the Department's assistance regulations (parts 3015, 3016, and 3019 of 7 CFR, as amended).

2. Organizational Management Information

Specific management information relating to an applicant shall be submitted on a one-time basis prior to the award of a grant identified under this program if such information has not been provided previously under this or another program for which the sponsoring agencies are responsible. Copies of forms recommended for use in fulfilling the requirements contained in this section will be provided by USDA as part of the pre-award process.

3. Grant Award Document and Notice of Grant Award

The grant award document shall include at a minimum the following:

- a. Legal name and address of performing organization or institution to whom the Administrator has awarded a grant under the terms of this request for proposals;
- b. Title of Project;
- c. Name(s) and address(es) of project director(s) chosen to direct and control approved activities;
- d. Identifying grant number assigned by the Department;
- e. Project period, specifying the amount of time the Department intends to support the project without requiring recompetition for funds;
- f. Total amount of Department financial assistance approved by the Administrator during the project period;
- g. Legal authority(ies) under which the grant is awarded;
- h. Approved budget plan for categorizing allocable project funds to accomplish the stated purpose of the grant award; and
- i. Other information or provisions deemed necessary by CSREES to carry out their respective granting activities or to accomplish the purpose of a particular grant.

4. Notice of Grant Award

The notice of grant award, in the form of a letter, will be prepared and will provide pertinent instructions or information to the grantee that is not included in the grant award document.

5. CSREES will award standard grants to carry out this program. A standard grant is a funding mechanism whereby

CSREES agrees to support a specified level of effort for a predetermined time period without additional support at a future date.

C. Use of Funds; Changes

1. Delegation of Fiscal Responsibility

The grantee may not in whole or in part delegate or transfer to another person, institution, or organization the responsibility for use or expenditure of grant funds.

2. Changes in Project Plans

a. The permissible changes by the grantee, project director(s), or other key project personnel in the approved project grant shall be limited to changes in methodology, techniques, or other aspects of the project to expedite achievement of the project's approved goals. If the grantee and/or the project director(s) are uncertain as to whether a change complies with this provision, the question must be referred to the CSREES Authorized Departmental Officer for a final determination.

b. Changes in approved goals, or objectives, shall be requested by the grantee and approved in writing by the CSREES Authorized Departmental Officer prior to effecting such changes. In no event shall requests for such changes be approved which are outside the scope of the original approved project.

c. Changes in approved project leadership or the replacement or reassignment of other key project personnel shall be requested by the grantee and approved in writing by the awarding official of CSREES prior to effecting such changes.

d. Transfers of actual performance of the substantive programmatic work in whole or in part and provisions for payment of funds, whether or not Federal funds are involved, shall be requested by the grantee and approved in writing by the Department prior to effecting such transfers.

e. Changes in Project Period: The project period may be extended by CSREES without additional financial support, for such additional period(s) as the Authorized Departmental Officer determines may be necessary to complete or fulfill the purposes of an approved project. Any extension of time shall be conditioned upon prior request by the grantee and approval in writing by the Authorized Departmental Officer, unless prescribed otherwise in the terms and conditions of a grant.

f. Changes in Approved Budget: Changes in an approved budget must be requested by the grantee and approved in writing by the authorized

departmental officer prior to instituting such changes if the revision will:

(1) Involve transfers of amounts budgeted for indirect costs to absorb an increase in direct costs;

(2) Involve transfers of amounts budgeted for direct costs to accommodate changes in indirect cost rates negotiated during a budget period and not approved when a grant was awarded; or

(3) Involve transfers or expenditures of amounts requiring prior approval as set forth in the applicable Federal cost principles, Departmental regulations, or in the grant award.

D. Other Federal Statutes and Regulations that Apply

Several other Federal statutes and regulations apply to grant proposals considered for review and to project grants awarded under this program. These include but are not limited to:

7 CFR Part 1.1, subpart A—USDA implementation of the Freedom of Information Act.

7 CFR Part 3, as amended—USDA implementation of OMB Circular No. A-129 regarding debt collection.

7 CFR Part 15, subpart A—USDA implementation of Title VI of the Civil Rights Act of 1964, as amended.

7 CFR Part 3015, as amended—USDA Uniform Federal Assistance Regulations, implementing OMB directives (i.e., Circular Nos. A-21, and A-122) and incorporating provisions of 31 U.S.C. 6301-6308 (formerly the Federal Grant and Cooperative Agreement Act of 1977, Pub. L. 95-224), as well as general policy requirements applicable to recipients of Departmental financial assistance.

7 CFR Part 3016, as amended—Uniform Administrative Requirements for Grants and Cooperative Agreements to State and Local Governments.

7 CFR Part 3017—USDA implementation of Governmentwide Debarment and Suspension (Nonprocurement) and Governmentwide Requirements for Drug-Free Workplace (Grants).

7 CFR Part 3018—USDA implementation of New Restrictions on Lobbying. Imposes new prohibitions and requirements for disclosure and certification related to lobbying on recipients of Federal contracts, grants, cooperative agreements, and loans.

7 CFR Part 3019, as amended—USDA implementation of OMB Circular A-110, Uniform Administrative Requirements for Grants and Other Agreements With Institutions of Higher Education, Hospitals, and Other Nonprofit Organizations.

7 CFR Part 3052 (62 FR 45947, August 29, 1997)—USDA implementation of OMB Circular No. A-133 regarding audits of States, local governments, and nonprofit organizations.

48 CFR Part 31, as amended—Contract Cost Principles and Procedures of the Federal Acquisition Regulation.

29 U.S.C. 794, section 504 of the Rehabilitation Act of 1973, and 7 CFR Part 15B (USDA implementation of statute), prohibiting discrimination based upon physical or mental handicap in Federally assisted programs.

35 U.S.C. 200 et seq.—Bayh-Dole Act, controlling allocation of rights to inventions made by employees of small business firms and domestic nonprofit organizations, including universities, in Federally assisted programs (implementing regulations are contained are contained in 37 CFR part 401).

E. Confidential Aspects of Proposals and Awards

When a proposal results in a grant, it becomes a part of the record of the Agency's transactions, available to the public upon specific request. Information that the Secretary determines to be of a privileged nature will be held in confidence to the extent permitted by law. Therefore, any information that the applicant wishes to have considered as privileged should be clearly marked as such and sent in a separate statement, two copies of which should accompany the proposal. The original copy of a proposal that does not result in a grant will be retained by the Agency for a period of one year. Other copies will be destroyed. Proposals that do not receive a grant will be released to others only with the consent of the applicant or to the extent required by law. If such a request is made, the applicant will be consulted prior to release of the proposal. A proposal may be withdrawn at any time prior to the final selection action thereon.

F. Evaluation of Program

All grantees shall be expected to assist USDA by providing relevant information on their respective projects. Applicants also are encouraged to plan for their own internal self-assessments and evaluations to measure the effectiveness of each project.

G. Regulatory Information

For the reasons set forth in the final Rule-related Notice to 7 CFR part 3015, subpart V (48 FR 29115, June 24, 1983), this program is excluded from the scope of the Executive Order 12372 which requires intergovernmental consultation with State and local officials.

Done at Washington, D.C., this 5th day of
February 1998.

B. H. Robinson,

*Administrator, Cooperative State Research,
Education, and Extension Service.*

Robert J. Prchal,

*Deputy Administrator for Insurance Services,
Risk Management Agency.*

Robert J. Prchal,

*Acting Manager, Federal Crop Insurance
Corporation.*

[FR Doc. 98-3419 Filed 2-9-98; 8:45 am]

BILLING CODE 3410-22-P

federal register

Tuesday
February 10, 1998

Part V

Department of Transportation

14 CFR Part 71

**Proposed Establishment of Cincinnati/
Northern Kentucky International Airport
Class B Airspace Area and Revocation of
Cincinnati/Northern Kentucky International
Airport Class C Airspace Area,
Covington, KY; Proposed Rule**

DEPARTMENT OF TRANSPORTATION

Federal Aviation Administration

14 CFR Part 71

[Airspace Docket No. 93-AWA-5]

RIN 2120-AE97

Proposed Establishment of Cincinnati/Northern Kentucky International Airport Class B Airspace Area and Revocation of Cincinnati/Northern Kentucky International Airport Class C Airspace Area, Covington, KY

AGENCY: Federal Aviation Administration, DOT.

ACTION: Notice of proposed rulemaking (NPRM).

SUMMARY: The Federal Aviation Administration (FAA) proposes to establish a Class B airspace area at the Cincinnati/Northern Kentucky International Airport, and revoke the existing Class C airspace area. Specifically, the FAA is proposing to establish a Class B airspace area that would consist of airspace with a 25-mile radius of the Cincinnati/Northern Kentucky International Airport. The airspace would extend from the surface or higher up to and including 8,000 feet above mean sea level (MSL). The FAA is proposing this action to enhance safety, reduce the potential for midair collisions, and to better manage air traffic operations into, out of, and through the Cincinnati/Northern Kentucky area.

DATES: Comments must be received on or before April 13, 1998.

ADDRESSES: Comments on this NPRM should be mailed, in triplicate, to: Federal Aviation Administration, Office of the Chief, Attention: Rules Docket (AGC-200), Airspace Docket No. 93-AWA-5, 800 Independence Avenue, SW., Washington, DC 20591. Comments may be also sent electronically to the following *Internet address*: 9-NPRM-CMTS@faa.dot.gov. Comments delivered must be marked Airspace Docket No. 93-AWA-5. The official docket may be examined in the Office of the Chief Counsel, Room 915G, weekdays, between 8:30 a.m. and 5:00 p.m., except on Federal holidays. An informal docket may also be examined during normal business hours at the Office of the Regional Air Traffic Division.

FOR FURTHER INFORMATION CONTACT: Patricia Crawford, Airspace and Rules Division, ATA-400, Office of Air Traffic Airspace Management, Federal Aviation Administration, 800 Independence

Avenue, SW., Washington, DC 20591; telephone (202) 267-8783.

SUPPLEMENTARY INFORMATION:**Comments Invited**

Interested persons are invited to participate in the rulemaking process by submitting such written data, views, or arguments as they may desire. Comments on the environmental, energy, federalism, or economic impact that might result from adopting the proposals in this notice are also invited. Substantive comments should be accompanied by cost estimates.

Comments should identify the airspace docket number and should be submitted in triplicate to the Rules Docket address specified above. All comments received by the closing date for comments specified will be considered by the Administrator before acting on this proposed rulemaking. The proposals contained in this notice may be changed considering comments received. All comments received will be available, both before and after the closing date for comments, in the Rules Docket for examination by interested persons. A report summarizing each substantive public contact with FAA personnel concerned with this rulemaking will be filed in the docket.

Commenters wishing the FAA to acknowledge receipt of their comments submitted in response to this notice must include a self-addressed, stamped postcard on which the following statement is made: "Comment to Docket No. 93-AWA-5." The postcard will be date/time stamped and returned to the commenter.

Availability of NPRM

An electronic copy of this document may be downloaded using a modem and suitable communications software from the FAA regulations section of the Fedworld electronic bulletin board service (telephone: 703-21-3339) or the Government Printing Office's electronic bulletin board service (telephone: 202-512-1661).

Internet users may reach the FAA's web page at <http://www.faa.gov> or the Superintendent of Documents' webpage at http://www.access.gpo.gov/su_docs/ for access to recently published rulemaking documents.

Any person may obtain a copy of this NPRM by mail by submitting a request to the Federal Aviation Administration, Office of Rulemaking, 800 Independence Avenue, SW., Washington, DC 20591, or by calling 202-267-9677. Communications must identify the notice number of this NPRM.

Persons interested in being placed on the mailing list for future NPRM's should request from the FAA's Office of Rulemaking a copy of Advisory Circular No. 11-2A, Notice of Proposed Rulemaking Distribution System, that describes the application procedure.

Background

The Class B airspace (formerly terminal control area (TCA)) area program was developed to reduce the potential for midair collision in the congested airspace surrounding airports with high density air traffic by providing an area wherein all aircraft are subject to certain operating rules and equipment requirements.

The density of traffic and the type of operations being conducted in the airspace surrounding major terminals increase the potential for midair collisions. In 1970, an extensive study found that the majority of midair collisions occurred between a general aviation (GA) aircraft and an air carrier or military aircraft, or another GA aircraft. The basic causal factor common to these conflicts was the mix of aircraft operating under visual flight rules (VFR) and aircraft operating under instrument flight rules (IFR). Class B airspace areas provide a method to accommodate the increasing number of IFR and VFR operations. The regulatory requirements of Class B airspace areas afford the greatest protection for the greatest number of people by giving air traffic control (ATC) increased capability to provide aircraft separation service, thereby minimizing the mix of controlled and uncontrolled aircraft.

On May 21, 1970, the FAA published the Designation of Federal Airway, Controlled Airspace, and Reporting Points Final Rule (35 FR 7782). This rule provided for the establishment of TCA's. To date, the FAA has established a total of 29 Class B airspace areas. The FAA is proposing to take action to modify or implement the application of these proven control areas to provide greater protection for air traffic in the airspace areas most commonly used by passenger-carrying aircraft.

The standard configuration of a Class B airspace area contains three concentric circles centered on the primary airport, extending to 10, 20, and 30 nautical miles (NM) respectively. The standard vertical limits of the Class B airspace area normally should not exceed 10,000 feet MSL, with the floor established at the surface in the inner area and at levels appropriate for the containment of operations in the outer areas. Variation of these criteria may be utilized contingent on the terrain,

adjacent regulatory airspace, and factors unique to the terminal area.

Cincinnati/Northern Kentucky International Airport reported 5,044,813 and 5,780,241 enplaned passengers in calendar years (CY) 1991 and 1992. The enplaned passenger count has increased to 9,225,526 in CY 1996. Operations at that airport have increased from 297,869 and 304,214 in fiscal years (FY) 1991 and 1992 to 393,523 in FY 1996. Cincinnati/Northern Kentucky International Airport qualifies as a candidate for establishing Class B airspace based on the passenger enplanement and airport operations count.

The coordinates for this airspace docket are based on North American Datum 83. Class B and Class C airspace areas are published in paragraphs 3000 and 4000, respectively, of FAA Order 7400.9E dated September 10, 1997, and effective September 15, 1997, which is incorporated by reference in Title 14 of the Code of Federal Regulations (14 CFR) part 71. The Class B airspace area listed in this document would be published subsequently in the Order and the Class C airspace area would be removed subsequently from the Order.

Related Rulemaking Actions

On June 21, 1988, the FAA published the Transponder with Automatic Altitude Reporting Capability Requirement Final Rule (53 FR 23356). This rule requires all aircraft to have an altitude encoding transponder when operating within 30 NM of any designated TCA primary airport, from the surface up to 10,000 feet MSL. This rule excluded those aircraft that were not originally certificated with an engine driven electrical system, (or those that have not subsequently been certified with such a system), balloons, or gliders.

On October 14, 1988, the FAA published the TCA Classification and TCA Pilot and Navigation Equipment Requirements Final Rule (53 FR 40318). This rule, in part, removed the different classifications of TCA's, and requires the pilot-in-command of civil aircraft operating within a TCA to hold at least a private pilot certificate, except for a student pilot who has received certain documented training.

On December 17, 1991, the FAA published the Airspace Reclassification Final Rule (56 FR 65655). This rule discontinued the use of the term "Terminal Control Area" (TCA) and replaced it with the designation "Class B airspace area." This change in terminology is reflected in this NPRM.

Pre-NPRM Public Input

As announced in the Federal Register on July 23, 1992 (57 FR 32835), informal airspace meetings were held on September 3 and 4, 1992, in Ohio and Kentucky respectively. These meetings allowed the public an opportunity to preview and comment on the proposed design for the Cincinnati/Northern Kentucky International Airport Class B airspace area. Comments were received from owners and managers of the local GA airports, members of the aviation industry, fixed-base operators (FBO), and concerned airspace users. An Ad Hoc User Group Advisory Committee was established and submitted seven recommendations in conjunction with their Class B airspace design proposal.

All comments received during the informal airspace meetings and the subsequent comment period were considered and incorporated, in this NPRM. The following is an analysis of these comments.

Discussion of Comments

Several commenters recommended modifications to the northeast (NE) quadrant of the proposed Class B airspace to accommodate VFR aircraft operating to and from Blue Ash, Clermont County, and Hamilton-Fairfield Airports, without a Mode C transponder. Comments from the Experimental Aircraft Association (EAA) and Lebanon Air Service specifically recommended designating the floor of the Class B airspace in the vicinity of these aforementioned satellite airports at a minimum of 3,500 feet MSL. The reasoning for this recommendation is that a Mode C transponder would not be required because aircraft would be operating below and outside of the Class B airspace area. EAA stated that certain benefits would be derived because pilots would not be required to contact air traffic control (ATC) thus limiting frequency congestion. In addition, prominent landmarks could be utilized to navigate and a discrete code could be assigned to assist ATC with monitoring activity, if necessary.

The Ad Hoc Advisory Committee submitted a recommendation with emphasis on serving traffic operating to and from the satellite airports and expediting the flow of traffic within the lateral boundaries of the proposed Class B airspace area. In addition, the committee recommended that a satellite airport controller position, with a supporting data position, be added to the ATC facility.

The FAA agrees, in part, with these recommendations, the floors of the

Cincinnati/Northern Kentucky International Airport Class B airspace area in the vicinity of Clermont County, Blue Ash, and Hamilton-Fairfield are proposed to be 6,000; 5,000; and 4,000 feet MSL, respectively. The FAA believes that designating the Class B airspace area floors at these altitudes would allow sufficient airspace for aircraft transitioning to and from the subject satellite airports.

Currently, air traffic regulations allow pilots to transition below the floor of the Class B airspace without contacting an ATC facility. Aircraft operating within a 30-mile radius of the Class B airspace primary airport are required to have the appropriate equipment as outlined in § 91.215. Requests to operate without the § 91.215 equipment are handled on a case-by-case basis, and must be made to the ATC facility having jurisdiction over the affected airspace.

The FAA has budgeted for an additional radar controller and flight data position at the Cincinnati/Northern Kentucky International Airport. The new positions will be added as a result of an increase in traffic, and are not related to the actions proposed in this NPRM. Efforts are ongoing to secure the necessary equipment to activate the positions in a timely manner. Once the equipment is available and the position certified operational, the Air Traffic Manager of the Cincinnati Airport Traffic Control Tower (ATCT) will determine how the new position(s) would best be utilized.

Several commenters objected to the lateral (25 NM radius) and vertical (8,000 feet MSL) limits of the proposed Class B airspace area. One commenter expressed concern that the proposed Cincinnati/Northern Kentucky International Airport Class B airspace area appears to be larger than other established Class B areas. One commenter recommended that the lateral boundaries of the Cincinnati/Northern Kentucky International Airport Class B airspace be limited to a 20 NM radius.

Most of the comments received supported a proposed ceiling of 8,000 feet MSL.

A representative for Sporty's Shops recommended 6,000 feet MSL for the ceiling of the proposed Class B airspace area.

The Air Transport Association of America (ATA) objected to the proposed ceiling at 8,000 feet and recommended a ceiling of 10,000 feet MSL. The ATA suggested that by establishing the ceiling at 10,000 feet MSL, the potential for a disaster would be reduced because fewer aircraft would be operating within that airspace between 8,000 and 10,000

feet MSL. In addition, ATA voiced concern that aircraft flying over the ASR antenna, would not be seen by the controller for two or three sweeps of the antenna.

The proposed Cincinnati/Northern Kentucky International Airport Class B airspace area is unique with a site specific design to support Cincinnati/Northern Kentucky International Airport aircraft operations and to contain all published instrument approach procedures. The loss of a radar return as an aircraft passes over the radar antenna is a common occurrence in any terminal radar environment. Consequently, there are sufficient traffic management procedures in place to address these situations. The FAA believes that the proposed 8,000 feet MSL ceiling and 25-nautical mile lateral boundary would be sufficient and not be over-restrictive.

Lunken Airport Advisory and Users' Committee and the Lunken Airport Action Group (LAAG) recommended a change in the vicinity of Lunken Airport, Area D east of the Cincinnati/Northern Kentucky International Airport. The committee suggested that the floor in Area D should be raised from 3,500 to 4,000 feet MSL to preserve 3,500 feet as a VFR altitude. The committee believes that this recommendation is plausible since Runways 09/27 at the Cincinnati/Northern Kentucky International Airport are seldom utilized for approaches, therefore, a lower floor is not supported.

The Flying Knights, located at Lunken Airport, submitted comments which parallel those of the Airport Advisory and Users Committee. Furthermore, the Knights commented that any lower altitudes would cause unnecessary congestion and noise disturbance to the surrounding residential area.

The FAA does not agree with these commenters. The base altitude in Area D east of the airport, at 3,500 feet MSL, would ensure that pilots executing the instrument landing system (ILS) approach procedures for Runways 09/27 remain within Class B airspace. Currently, Runways 09/27 are utilized less than the parallel north-south runways. However, traffic demands and varying meteorological conditions necessitate the structure of Area D with a 3,500 foot MSL floor.

Sporty's Academy, Inc., conducts flight instruction in the vicinity of Clermont Airport. Less than 15 miles east of Clermont Airport is the western boundary of Buckeye Military Operations Area (MOA) (Restricted Area R-5503A was downgraded to Buckeye Military Operations Area (MOA) in

February 1995). At the narrowest point, the "gap" between the Buckeye MOA and the eastern edge of the Class B airspace area would be approximately 10 NM. This commenter believes that aircraft transitioning north and south would have to circumnavigate the Class B airspace area east of the Cincinnati/Northern Kentucky International Airport. Consequently, these aircraft could be compressed between the Class B airspace area and the Buckeye MOA into an area of high density student flight training. Sporty's Academy, Inc., recommended that the FAA give serious consideration to widening that "gap".

Another commenter recommended that the Class B airspace area be limited to 15 NM east of the Cincinnati/Northern Kentucky International Airport.

The FAA encourages pilots to follow standard air traffic procedures and participate in, rather than circumnavigate Class B airspace areas. In addition, the FAA asserts that sufficient airspace exists for pilots to circumnavigate the proposed Class B area, avoid the Buckeye MOA if active, and coexist with the student training activity if they chose not to navigate thru the proposed Class B airspace area.

Lane's Lebanon Air Service, Inc., suggested establishing an area around the Lebanon-Warren County Airport to accommodate gliders, towplanes, and other aircraft not equipped with Mode C transponders. This commenter emphasized that one of its main sources of revenue is generated from passenger rides in gliders. Several times a day, the commenter operates its gliders over Kings Island Amusement Park at an altitude of 6,200 feet MSL. It is Lebanon Air Service's opinion that the proposed Class B airspace area would have a negative impact on its business.

The FAA has determined that the implementation of the proposed Class B airspace area would have an insignificant or no impact on glider operations between the Lebanon-Warren County Airport and Kings Island Amusement Park because the operations would be conducted outside of the Class B airspace area.

The fixed based operator (FBO) at Hamilton-Fairfield Airport suggested a cutout north along the Great Miami River to exclude the airport from the Class B airspace. Implementing this proposal would be beneficial to the large number of experimental and antique aircraft based at that airport.

The FAA has proposed to designate the floors of the Class B airspace at 3,500-4,000 feet MSL in the vicinity of Hamilton-Fairfield Airport. The airport would be below the floor of the class B

airspace area which should provide airspace for egress/ingress.

The Ad Hoc Advisory Committee, Aircraft Owners and Pilots Association (AOPA), and Sporty's Shops recommended that the FAA relocate the Cincinnati very high frequency omnidirectional range tactical air navigation (VORTAC) to the airport property before the proposed Class B airspace is implemented. In these commenters' opinion, relocating the Cincinnati VORTAC would simplify the identification of the Class B airspace boundaries for transient and local pilots. In addition, the commenters recommended that the FAA install a Doppler radar antenna in conjunction with relocating the navigational aid (NAVAID).

Furthermore, AOPA recommended a test to determine the feasibility of relocating the Cincinnati VORTAC to the airport property.

The FAA appreciates these comments; however, the FAA has determined that measures such as relocating the NAVAID are not necessary or practicable. Additionally, the FAA has installed Doppler Radar System at the CVG.

During the preliminary stages of planning, the FAA attempted to define as many boundaries of the Class B airspace area by prominent landmarks as feasible (e.g., aligning boundaries with major roads, rivers, or powerlines). In the absence of the Cincinnati VORTAC, these geographic landmarks can be utilized to assist pilots with identifying the lateral boundaries of the Class B airspace area, and assisted by normal navigating procedures.

Several rotorcraft operators suggested that the FAA implement a "rotorcraft only" VFR corridor in the Ohio River Valley north of the Cincinnati/Northern Kentucky International Airport. The corridor's ceiling would be 900 feet MSL.

EAA Chapter 174 recommended a VFR corridor northwest of the Class B airspace area, to include Cincinnati West and Miamitown Airports. The EAA proposed establishing the ceiling of this corridor below 3,000 feet MSL, and to allow aircraft to operate within the corridor without a Mode C transponder.

The FAA does not agree with these suggestions because the establishment of a VFR corridor could interfere with safe and efficient operations in the Class B airspace area. The establishment of an uncontrolled VFR corridor for nonparticipating rotorcraft north of the airport, under the final approach courses for Runways 18L/18R and the departure paths for Runways 36L/36R,

would impede operations. Arriving and departing turbojet aircraft cross this area at very low altitudes. Consequently, the incorporation of a VFR rotorcraft corridor could result in unsafe conditions as well as difficulties with wake turbulence.

Currently, there is an established letter of agreement between Cincinnati/Northern Kentucky International Airport and local helicopter operators for controlled routes to and from the airport. If the need arises, the facility manager will, as necessary, work with other airspace users to develop or modify the appropriate procedural agreements.

The Proposal

The FAA proposes to amend 14 CFR part 71 by establishing a Class B airspace area at the Cincinnati/Northern Kentucky International Airport, and by revoking the Cincinnati/Northern Kentucky International Airport Class C airspace area. The proposal to establish this Class B airspace area is based on aviation safety and operational efficiencies.

The proposed establishment, depicted in the attached chart, considers flight operations and terrain. Specifically, the areas would be established as follows:

Area A. Airspace within a 5-mile radius of the primary airport, Cincinnati/Northern Kentucky International Airport, extending upward from the surface to and including 8,000 feet MSL. This airspace is necessary to contain large turbojet aircraft within the limits of the Class B airspace area while operating to and from the primary airport.

Area B. Airspace between the 5- and 10-mile radius of the primary airport extending upward from 2,100 feet MSL to and including 8,000 feet MSL. This airspace is necessary to support the approach procedures for aircraft transitioning to the final approach course for the Cincinnati/Northern Kentucky International Airport.

Area C. Airspace between the 10- and 15-mile arcs, north and south of the primary airport extending upward from 3,000 feet MSL to and including 8,000 feet MSL. This area is necessary to provide sufficient airspace for sequencing and vectoring arriving and departing aircraft in close proximity to the primary airport.

Area D. Airspace between the 10- and 15-mile arcs east and west from the primary airport, and airspace between the 15- and 20-mile arcs north and south from the primary airport, extending upward from 3,500 feet MSL to and including 8,000 feet MSL. These airspace areas are necessary for

sequencing and vectoring aircraft and to ensure that operations are contained within Class B airspace.

Area E. This airspace provides a controlled environment for aircraft arriving and departing the Class B airspace area. Area E consists of designated airspace between the 20- and 25-mile arc north and south of the primary airport extending upward from 4,000 feet MSL to and including 8,000 feet MSL.

Area F. Airspace encompasses an area from northeast through southeast, and southwest through northwest of the Class B airspace area, extending upward from 5,000 feet MSL to and including 8,000 feet MSL. Area F is necessary to ensure that aircraft have sufficient airspace to maneuver within the Class B airspace area and a controlled environment while preparing for the approach or executing departure procedures. Also, this airspace is designed to allow nonparticipating aircraft sufficient airspace to conduct VFR operations below the vertical limits of the Class B airspace area while transitioning to/from secondary satellite airports.

Area G. This airspace would be established east of the primary airport extending from the powerlines eastward to the 25-mile arc from the primary airport, extending upward from 6,000 feet MSL to and including 8,000 feet MSL. This area is necessary to allow adequate airspace to contain aircraft in a controlled environment when transitioning between the en route and terminal phase of flight.

Regulatory Evaluation Summary

Proposed changes to Federal regulations must undergo several economic analyses. First, Executive Order 12866 directs that each Federal agency shall propose or adopt a regulation only upon a reasoned determination that the benefits of the intended regulation justify its costs. Second, the Regulatory Flexibility Act of 1980 requires agencies to analyze the economic effect of regulatory changes on small entities. Third, the Office of Management and Budget directs agencies to assess the effect of regulatory changes on international trade. In conducting these analyses, the FAA has determined that this Notice of Proposed Rulemaking (NPRM): (1) would generate benefits that justify its minimal costs and is not "a significant regulatory action" as defined in the Executive Order; (2) is not significant as defined in the Department of Transportation's Regulatory Policies and Procedures; (3) would not have a significant impact on a substantial

number of small entities; (4) would not constitute a barrier to international trade; and (5) would not contain any Federal intergovernmental or private sector mandate. Therefore, the requirements of Title II of the Unfunded Mandates Reform Act of 1995 do not apply. These analyses are summarized here in the preamble and the full Regulatory Evaluation is in the docket.

This NPRM would establish the Cincinnati Class B airspace area at Cincinnati/Northern Kentucky International Airport and revoke the Cincinnati Class C airspace area at Cincinnati/Northern Kentucky International Airport (CVG). The Cincinnati Class B airspace area would consist of the airspace up to and including 8,000 feet mean sea level (MSL) from the surface or higher (various sector floor levels) within a 25-mile radius of the Cincinnati/Northern Kentucky International Airport. The establishment of a Class B airspace area at the CVG would impose more stringent operating rules and equipment requirements on GA operators. Some of these Class B airspace requirements would include an operating two-way radio and a transponder with automatic altitude-reporting capability. Additional equipment requirements for IFR operations include an operable VOR or tactical air navigation (TACAN) receiver.

The NPRM would provide benefits to participating and nonparticipating operators primarily in the form of enhanced safety as well as to the aviation community and the flying public by increasing air traffic control's (ATC's) authority and capability to monitor and to separate aircraft in the terminal airspace around CVG.

The FAA has determined that this NPRM would impose minimal, if any, additional cost on the agency or aircraft operators. The FAA has determined this NPRM would impose costs of approximately \$74,000 (1996 dollars) to the agency for the revision of aeronautical charts for CVG.

The proposed rule would impose minimal, if any, equipment costs and only negligible circumnavigation costs on aircraft operators. This NPRM would require changes to the plates used to print those charts on which the proposed Class B airspace would be depicted. Printing the revised aeronautical charts to reflect the proposed change of the airspace around Cincinnati/Northern Kentucky would be accomplished during regularly scheduled chart printings. The National Oceanic Service (NOS), the agency responsible for the publication and distribution of aeronautical charts,

estimates that the total one-time cost of these changes would be \$74,000 (1996 dollars). The proposed rule would not impose any additional administrative costs on the FAA for either personnel or equipment. The additional operations workload generated by the proposed rule would be absorbed by current personnel and equipment resources at CVG. The proposed rule would require neither any additional air traffic controllers nor any additional radar control or hand-off positions.

In view of the minimal cost of compliance, enhanced safety and operational efficiency, the FAA has determined that the proposed rule would be cost-beneficial.

Initial Regulatory Flexibility Determination

The Regulatory Flexibility Act of 1980 (RFA) was enacted by Congress to ensure that small entities are not unnecessarily burdened by government regulations. The RFA requires agencies to review rules that may have a "significant economic impact on a substantial number of small entities."

Only those unscheduled aircraft operators without the capability to operate under IFR requirements would be potentially affected by the proposed rule. However, the FAA has determined the vast majority of unscheduled operators are already equipped to operate under IFR requirements. This is because such operators routinely fly into airspace where radar approach control services have been established.

The FAA has also determined that other local airspace users, such as balloonists, parachutists, ultralight and sailplane owners, and fixed base operators, would not have to significantly circumnavigate around the proposed Class B airspace. The FAA has determined that Cincinnati Approach Control can accommodate these users on a case-by-case basis and use letters of agreement and cutouts, where advisable, to ensure as little adverse impact as possible on these users. Therefore, the FAA has determined that this proposed rule would not have a significant economic impact on a substantial number of small entities.

International Trade Impact Assessment

The Office of Management and Budget directs agencies to assess the effects of regulatory changes on international trade. The FAA has determined that the proposed rule would neither have an effect on the sale of foreign aviation products or services in the United States, nor would it have an effect on the sale of U.S. products or services in foreign countries. This is because the

proposed rule would neither impose costs on aircraft operators nor aircraft manufacturers (U.S. or foreign).

Unfunded Mandates Assessment

Title II of the Unfunded Mandates Reform Act of 1995 (the act), enacted as Public Law 104-4 on March 22, 1995, requires each Federal agency, to the extent permitted by law, to prepare a written assessment of the effects of any Federal mandate in a proposed or final agency rule that may result in the expenditure of \$100 million or more adjusted annually for inflation in any one year by State, local, and tribal governments, in the aggregate, or by the private sector. Section 204(a) of the ACT, 2 U.S.C. 1534(a), requires the Federal agency to develop an effective process to permit timely input by elected officers (or their designees) of State, local and tribal governments on a proposed "significant intergovernmental mandate." A "significant intergovernmental mandate" under the act is any provision in a Federal agency regulation that would impose an enforceable duty upon state, local, and tribal governments, in the aggregate, (of \$100 million adjusted annually for inflation) in any one year. Section 203 of the ACT, 2 U.S.C. 1533, which supplements section 204(a), provides that before establishing any regulatory requirements that might significantly or uniquely affect small governments, the agency shall have developed a plan that among other things, provides for notice to potentially affected small governments, if any, and for a meaningful and timely opportunity to provide input in the development of regulatory proposals.

This NPRM does not contain any Federal intergovernmental or private sector mandate. Therefore, the requirements of Title II of the Unfunded Mandates Reform ACT of 1995 do not apply.

Paperwork Reduction Act

In accordance with the Paperwork Reduction Act of 1995 (44 U.S.C. 3507(d)), there are no requirements for information collection associated with this rule.

Conclusion

The FAA has determined that this regulation: (1) is not a significant rule under Executive Order 12866; and (2) is not a significant rule under Department of Transportation Regulatory Policies and Procedures (44 FR 11034; February 26, 1979). Also, for the reasons stated under the headings "Trade Impact Statement" and Regulatory Flexibility Determination," the FAA certifies that

the NPRM will not have a significant economic impact on a substantial number of small entities. A copy of the full regulatory evaluation is filed in the docket and may also be obtained by contacting the person listed in the FOR FURTHER INFORMATION CONTACT.

List of Subjects in 14 CFR Part 71

Airspace, Incorporation by Reference, Navigation (Air).

The Proposed Amendment

The Federal Aviation Administration proposes to amend 14 CFR Part 71 as follows:

PART 71—DESIGNATION OF CLASS A, CLASS B, CLASS C, CLASS D, AND CLASS E AIRSPACE AREAS; AIRWAYS; ROUTES; AND REPORTING POINTS

1. The authority citation for part 71 continues to read as follows:

Authority: 49 U.S.C. 106(g), 40103, 40113, 40120; E.O. 10854, 24 FR 9565, 3 CFR, 1959-1963 Comp., p. 389.

§ 71.1 [Amended]

2. The incorporation by reference in 14 CFR 71.1 of the Federal Aviation Order 7400.9E, Airspace Designations and Reporting Points, dated September 10, 1997, and effective September 15, 1997, is amended as follows:

Paragraph 3000—Subpart B—Class B Airspace
* * * * *

ASO KY B Cincinnati/Northern Kentucky International Airport, KY [NEW]

Cincinnati/Northern Kentucky International Airport (Primary Airport)
(Lat. 39°02'43" N., long. 84°39'43" W.)
Cincinnati VORTAC
(Lat. 39°00'57" N., long. 84°42'12" W.)

Boundaries

Area A. That airspace extending upward from the surface to and including 8,000 feet MSL within a radius of 5 miles from the Cincinnati/Northern Kentucky International Airport.

Area B. That airspace extending upward from 2,100 feet MSL to and including 8,000 feet MSL beginning at the 5-mile arc of the airport and the Kentucky bank of the Ohio River northeast of the airport; northeast along the Kentucky bank of the Ohio River to the 10-mile arc of the airport; thence clockwise to the Kentucky bank of the Ohio River southwest of the airport, north along the Kentucky bank of the Ohio River to the Indiana-Ohio State line (long. 84°49'00" W); thence north to Interstate 275; follow Interstate 275 northeast to Interstate 74; thence east on Interstate 74 to CVG VORTAC 040° radial; thence southwest on the CVG VORTAC 040° radial to the 5-mile arc of the airport; thence clockwise on the 5-mile arc to the point of beginning.

Area C. That airspace extending upward from 3,000 feet MSL to and including 8,000

feet MSL beginning at the intersection of Interstate 275 and Indiana-Ohio State line (long. 84°49'00" W); thence north on the Indiana Ohio State line, to intersect the 15-mile arc of the airport; thence clockwise on the 15-mile arc to long. 84°30'00" W; thence south on long. 84°30'00" W to the 10-mile arc of the airport; thence clockwise on the 10-mile arc to the Kentucky bank of the Ohio River; proceed along the Kentucky bank of the Ohio River west to the 5-mile arc of the airport; thence counterclockwise along the 5-mile arc to the CVG VORTAC 040° radial; thence northeast along the CVG VORTAC 040° radial to Interstate 74; proceed west along Interstate 74 to Interstate 275; thence west along Interstate 275 to the point of beginning.

That airspace beginning at the 10-mile arc of the airport and long. 84°30'00" W; thence south along long. 84°30'00" W to the 15-mile arc of the airport; thence clockwise along the 15-mile arc to the Kentucky bank of the Ohio River; thence north along the Kentucky bank of the Ohio River to the 10-mile arc of the airport; thence counterclockwise along the 10-mile arc to the point of beginning.

Area D. That airspace extending upward from 3,500 feet MSL to and including 8,000 feet MSL beginning at lat. 39°09'21"N and the 10-mile arc northeast of the airport; thence east to the 15-mile arc of the airport; thence clockwise on the 15-mile arc to lat. 30°56'04"N; thence west on lat. 38°56'04"N to intersect the 10-mile arc of the airport; thence counterclockwise along the 10-mile arc to the point of beginning. That airspace beginning at the intersection of the Kentucky bank of the Ohio River and lat. 30°56'04"N; thence west along lat. 30°56'04"N to the 15-mile arc of the airport; clockwise on the 15-mile arc to lat. 39°09'21"N; thence east to Indiana-Ohio State line (long. 84°49'00" W); thence South along the Indiana-Ohio State line to the Kentucky bank of the Ohio River; thence south along the Kentucky bank of the Ohio River to point of beginning. That

airspace beginning at the intersection of the 15-mile arc of the airport and the Indiana-Ohio State line (long. 84°49'00" W) proceed north to the 20-mile arc of the airport; thence clockwise along the arc to long. 84°30'00" W; thence south to the 15-mile arc of the airport; thence counterclockwise along the 15-mile arc to point of beginning. That airspace beginning at the intersection of the 15-mile arc southeast of the airport and long. 84°30'00" W; thence south to the 20-mile arc of the airport clockwise to long. 84°49'00" W; thence north to the Kentucky bank of the Ohio River; proceeding along the Kentucky bank of the Ohio River to the 15-mile arc of the airport; thence counterclockwise on the 15-mile arc to the point of beginning.

Area E. That airspace extending upward from 4,000 feet MSL to including 8,000 feet MSL beginning at the 20-mile arc of the airport and Indiana-Ohio State line (long. 84°49'00" W); thence north to the 25-mile arc of the airport; thence clockwise to long. 84°30'00" W; thence south to the 20-mile arc of the airport; thence counterclockwise on the 20-mile arc to the point of beginning. That airspace beginning at the 20-mile arc and long. 84°30'00" W south of the airport; thence south along the long. 84°30'00" W to the 25-mile arc of the airport; thence clockwise along the 25-mile arc to long. 84°49'00" W; thence north along long. 84°49'00" W to the 20-mile arc of the airport; thence counterclockwise along the 20-mile arc to the point of beginning.

Area F. That airspace extending upward from 5,000 feet MSL to and including 8,000 feet MSL beginning at the 25-mile arc north of the airport and long. 84°30'00" W; thence clockwise on the 25-mile arc of the airport to Route 28; thence southwest 3-miles to the power line; thence south along the power line to the Ohio River; thence south-southeast along the Ohio bank of the Ohio River to the 25-mile arc of the airport southeast; thence clockwise on the 25-mile arc of the airport to long. 84°30'00" W south

of the airport; thence north to the 10-mile arc of the airport; thence east along lat. 38°56'04"N to the 15-mile arc of the airport; thence north along the 15-mile arc of the airport to lat. 39°09'21"N; thence west to the 10-mile arc of the airport and long. 84°30'00" W; thence north to the point of beginning. That airspace beginning at the 25-mile arc of the airport and the Indiana-Ohio State line (long. 84°49'00" W) counterclockwise to long. 84°49'00" W south of the airport; thence north to the Kentucky bank of the Ohio River; thence north along the Kentucky bank of the Ohio River to lat. 38°56'04"N; thence west to the 15-mile arc of the airport; clockwise on the 15-mile arc of the airport to lat. 39°09'21"N; thence east to the Indiana-Ohio State line; thence north to the point of beginning.

Area G. That airspace extending upward from 6,000 feet MSL to and including 8,000 feet MSL beginning at the intersection of Route 28 and the 25-mile arc of the airport; thence southeast 3 miles to powerline; thence south along the powerline to the Ohio River; thence south-southeast along the Ohio bank of the Ohio River to the 25-mile arc southeast of the airport; thence counterclockwise along the 25-mile arc of the airport of the point of beginning.

* * * * *
Paragraph 4000—Subpart C—Class C
Airspace

* * * * *
ASO KY Cincinnati/Northern Kentucky
International Airport, KY [Removed]

* * * * *
Issued in Washington, DC, on February 4,
1998.

Reginald C. Matthews,
Acting Program Director for Air Traffic
Airspace Management.
[FR Doc. 98-3287 Filed 2-9-98; 8:45 am]
BILLING CODE 4910-13-M



Federal Register

Tuesday
February 10, 1998

Part VI

Department of Transportation

Federal Aviation Administration

14 CFR Part 135
Commercial Passenger-Carrying
Operations in Single-Engine Aircraft
Under Instrument Flight Rules; Proposed
Rule

DEPARTMENT OF TRANSPORTATION**Federal Aviation Administration****14 CFR Part 135**

[Docket No. 28743; Notice No. 98-11]

RIN 2120-AG55

Commercial Passenger-Carrying Operations in Single-Engine Aircraft Under Instrument Flight Rules

AGENCY: Federal Aviation Administration, DOT.

AGENCY: Notice of proposed rulemaking.

SUMMARY: The Federal Aviation Administration (FAA) is proposing to revise and clarify certain conditions and limitations in Part 135 for instrument flight rule (IFR), passenger-carrying operations in single-engine aircraft. The clarification is necessary to resolve ambiguity in the current rule over the requirement for redundant power for gyroscopic instrumentation. The intended effect of this action is to remove any ambiguity concerning the required power sources for the gyroscopic instruments required for flight under IFR for single engine aircraft involved in commercial, passenger carrying operations.

DATES: Comments must be received by March 12, 1998.

ADDRESSES: Comments on this notice should be submitted in triplicate to: Federal Aviation Administration, Office of the Chief Counsel, Attn: Rules Docket (AGC-200), Room 915-G, Docket No. 28743, 800 Independence Ave., SW, Washington, DC 20591.

Comments must be marked Docket No. 28743. Comments also may be submitted electronically to the following Internet address: 9-nprm-cmts@faa.dot.gov. Comments may be examined in room 915G weekdays between 8:30 a.m. and 5 p.m. except on Federal holidays.

FOR FURTHER INFORMATION CONTACT: Mr. Dan Meier, Flight Standards Service, Federal Aviation Administration, 800 Independence Ave., SW, Washington, DC, 20591 (202) 267-8166.

SUPPLEMENTARY INFORMATION:**Comments Invited**

Interested persons are invited to participate in the making of the proposed rule by submitting such written data, views, or arguments as they may desire. Comments relating to the environmental, energy, federal, or economic impact that might result from adopting the proposals in this notice are also invited. Substantive comments should be accompanied by cost

estimates, if appropriate. Comments should identify the regulatory docket or notice number and should be submitted in triplicate to the Rules Docket address specified above. All comments received on or before the specified closing date for comments will be considered by the Administrator before taking action on this proposed rulemaking. The proposals contained in this notice may be changed in light of comments received. All comments received will be available, both before and after the closing dates for comments, in the Rules Docket for examination by interested persons. A report summarizing each substantive contact with FAA personnel concerned with this rulemaking will be filed in the docket. Commenters wishing the FAA to acknowledge receipt of their comments submitted in response to this notice must include a pre-addressed, stamped postcard on which the following statement is made: "Comments to Docket No. 28743." The postcard will be date stamped and returned to the commenter.

Availability of NPRMs

An electronic copy of this document may be downloaded, using a modem and suitable communications software, from the FAA regulations section of the Fedworld electronic bulletin board service (703) 321-3339, the Federal Register's electronic bulletin board service ((202) 512-1661), or the FAA's Aviation Rulemaking Advisory Committee Bulletin Board service ((800) 322-2722 or (202) 267-5948).

Internet users may reach the FAA's web page at <http://www.faa.gov> or the Federal Register web page at http://www.access.gpo.gov/su_docs for access to recently published rulemaking documents.

Any person may obtain a copy of this NPRM by submitting a request to the Federal Aviation Administration, Office of Rulemaking, ARM-1, 800 Independence Ave, SW, Washington, DC 20591, or by calling (202) 267-9677. Communications must identify the notice number or docket number of this NPRM.

Persons interested in being placed on the mailing list for future NPRMs should request from the above office a copy of Advisory Circular No. 11-2A, Notice of Proposed Rulemaking Distribution System, which describes the application procedure.

Background

On August 6, 1997, the FAA published Amendment 135-70 (62 FR 42364) that allowed commercial, passenger-carrying operations under IFR in single-engine aircraft under certain

conditions and limitations, and eliminates the limited IFR provision of the current rule. The effective date for the new rule is May 4, 1998 (62 FR 45014) to allow operators to obtain the necessary parts and approvals, to modify their operations manuals and specifications, and to retrofit their aircraft. The FAA also established Special Federal Aviation Regulations (SFAR) 81 to accommodate those operators who may be ready to meet the requirements of the rule sooner than the effective date.

Discussion of the Proposed Rule

Current SFAR 81, paragraph 2(b) and 14 CFR 135.163(h) require single-engine, passenger-carrying aircraft flying IFR to have two independent sources of energy (with means of selecting either), of which at least one is an engine-driven pump or generator, each of which is able to drive all gyroscopic instruments and installed so that failure of one instrument or source does not interfere with the energy supply to the remaining instruments or the other energy source.

A question was raised as to whether this requirement would allow the use of a "split panel," in which gyroscopic instruments could be driven by different energy sources, including vacuum, bleed air, or electrical sources. This question was also raised when the original requirement for dual sources of energy for gyroscopic instruments was promulgated. In the October 10, 1978 (43 FR 46769) preamble discussion regarding § 135.163(h), the Agency stated that:

Other commenters state that § 135.163 prohibits "splitting" gyro instruments between electrical and vacuum sources and that defeats safety. For instrument panels with both electric and vacuum instruments, a pump or generator is unable to drive all gyroscopic instruments. The pilot must be able to select an energy source which will drive all gyros if the other source fails. Anything less under IFR conditions would derogate safety. *Where a split panel is desired, each engine must have both a generator and a vacuum pump.* (emphasis added)

Thus, in October 1978, the Agency clearly contemplated that split panels would be used and that failure of one energy source must not impact the operation of the gyroscopic instruments. This requirement can readily be met by multi-engine aircraft because 14 CFR parts 23 and 135 require each independent source of energy to be on separate engines and that the means of selecting the energy source be either automatic or manual. For single-engine aircraft, however, the issue centers on

whether one energy source must be able to drive all gyroscopic instruments. While a single engine airplane does not provide engine redundancy, system redundancy is still required for each gyroscopic instrument.

Therefore, the FAA has determined that a "split panel," i.e., instruments driven by separate and independent sources, is an acceptable configuration for single-engine aircraft provided that each required gyroscopic instrument has a redundant energy source. This means that if any one energy source fails, all gyroscopic instruments must remain operable. This does not mean, however, that each source must drive *all* of the instruments, but rather that the failure of any one source would not result in the loss of energy to any gyroscopic instrument powered by that energy source.

For example, an acceptable configuration would be a gyroscopic direction indicator powered by redundant electrical sources, and a gyroscopic pitch and bank indicator (with artificial horizon) powered by bleed air and vacuum sources. Failure of any one energy source would not affect operation of all of the gyroscopic instruments. Thus, in this example, if one electrical source fails there is a redundant electrical system to power the direction indicator, and the artificial horizon indicator continues to be powered by the vacuum or bleed air system.

Therefore, to clarify that although each independent source of energy need not drive all gyroscopic instruments, and that each gyroscopic instrument must be powered by redundant sources, the Agency has deleted the phrase "all gyroscopic instruments," and has replaced it with the phrase "all gyroscopic instruments powered by, or to be powered by, that particular source."

The FAA also wishes to clarify that where single-engine, passenger-carrying IFR operations are flown with a single pilot and an autopilot, only the gyroscopic instruments on the pilot's panel need be operable and powered by redundant energy sources. However, where such operation is to be flown with both a pilot and a co-pilot, the gyroscopic instruments on both panels must be operable and powered by redundant energy sources.

Another question was raised as to the meaning of the phrase "means of selecting either," as it pertains to energy source redundancy. As discussed above, § 23.1331(c) requires that the means of selecting energy sources be either

automatic or manual. In the example cited above, § 23.1331 would be met because when the direction indicator failed, the redundant electrical source powering that instrument automatically allowed for its continued operation.

Regulatory Analyses

The FAA is proposing this change because some commenters to the final rule on Commercial Passenger-Carrying Operations in Single-Engine Aircraft under Instrument Flight Rules had questions on the redundant sources of power to the gyroscopic flight instruments. This propose change will alleviate any ambiguity and clarify the regulatory requirements. Therefore, the FAA has determined that this regulation imposes no additional burden on any entity. Accordingly, it has been determined that the action (1) is not significant under Executive Order 12866 and (2) is not a significant rule under the Department of Transportation Regulatory Policies and Procedures (44 FR 11034; February 26, 1979). Also, because this proposed amendment is editorial in nature, no impact is expected to result and a full regulatory evaluation is not required. In addition, the FAA certifies that this proposal will not have a significant economic impact, either positive or negative, on a substantial number of small entities under the criteria of the Regulatory Flexibility Act.

International Trade Impact

The proposed amendment would not impose any costs on either U.S. or foreign operators. Therefore, a competitive trade disadvantage would not be incurred by either U.S. operators abroad or foreign operators in the United States.

Paperwork Reduction Act

This proposed rule contains no information collection requests requiring approval of the Office of Management and Budget pursuant to the Paperwork Reduction Act (44 U.S.C. 3507 *et seq.*).

List of Subjects in 14 CFR Part 135

Air taxis, Aircraft, Aviation safety, Safety, Single-engine aircraft.

For the reasons set out in the preamble, 14 CFR part 135 is proposed to be amended as set forth below:

PART 135—OPERATING REQUIREMENTS: COMMUTER AND ON-DEMAND OPERATIONS

1. The authority citation for part 135 continues to read as follows:

Authority: 49 U.S.C. 106(g), 40113, 44701–44702, 44705, 44709, 44711–44713, 44715–44717, 44722.

SFAR No. 81 [Amended]

2. Paragraph 2(b) of Special Federal Aviation Regulation No. 81 is revised to read as follows:

SFAR No. 81—Passenger-Carrying Single-Engine IFR Operations

2. * * *
(a) * * *

(b) Two independent sources of energy (with means of selecting either) of which at least one is an engine-driven pump or generator, each of which is able to drive all gyroscopic instruments powered by, or to be powered by, that particular source and installed so that failure of one instrument or source does not interfere with the energy supply to the remaining instruments or the other energy source, unless, for single-engine aircraft in all cargo operations only, the rate of turn indicator has a source of energy separate from the bank and pitch and direction indicators. For the purpose of this paragraph, for multi-engine aircraft, each engine-driven source of energy must be on a different engine.

* * * * *

3. Section 135.163 is amended by revising paragraph (h) to read as follows:

§ 135.163 Equipment requirements: Aircraft carrying passengers under IFR.

* * * * *

(h) Two independent sources of energy (with means of selecting either) of which at least one is an engine-driven pump or generator, each of which is able to drive all gyroscopic instruments powered by, or to be powered by, that particular source and installed so that failure of one instrument or source, does not interfere with the energy supply to the remaining instruments or the other energy source unless, for single-engine aircraft in all cargo operations only, the rate of turn indicator has a source of energy separate from the bank and pitch and direction indicators. For the purpose of this paragraph, for multi-engine aircraft, each engine-driven source of energy must be on a different engine.

* * * * *

Issued in Washington, D.C. on February 4, 1998.

Thomas E. Stuckey,

Director, Flight Standards Service.

[FR Doc. 98-3344 Filed 2-9-98; 8:45 am]

BILLING CODE 4910-13-M



federal register

Tuesday
February 10, 1998

Part VII

Department of Education

Fund for the Improvement of
Postsecondary Education (FIPSE)—
Special Focus Competition: European
Community/United States of America
Joint Consortia for Cooperation in Higher
Education and Vocational Education;
Notice

DEPARTMENT OF EDUCATION

[CFDA No. 84.116J]

Fund for the Improvement of Postsecondary Education (FIPSE)—Special Focus Competition: European Community/United States of America Joint Consortia for Cooperation in Higher Education and Vocational Education

Notice inviting applications for new awards for fiscal year (FY) 1998.

Purpose of Program: To provide grants or enter into cooperative agreements to improve postsecondary education opportunities by focusing on problem areas or improvement approaches in postsecondary education.

Eligible Applicants: Institutions of higher education or combinations of institutions and other public and private nonprofit educational institutions and agencies.

Deadline for Transmittal of Applications: April 17, 1998.

Deadline for Intergovernmental Review: June 17, 1998.

Applications Available: February 17, 1998.

Available Funds: \$1,485,000.

Estimated Range of Awards: \$100,000–\$175,000 for up to three years.

Estimated Average Size of Awards: \$160,000 for up to three years.

Estimated Number of Awards: 8.

Note: The Department is not bound by any estimates in this notice.

Project Period: Up to 36 months.

Applicable Regulations: The Education Department General Administrative Regulations (EDGAR) in 34 CFR parts 74, 75, 77, 79, 80, 82, 85 and 86.

SUPPLEMENTARY INFORMATION: For FY 1998, the competition also includes an invitational priority to encourage proposals designed to support the formation of educational consortia of institutions in the U.S. and the European Union to encourage cooperation in the coordination of curricula, the exchange of students and the opening of educational opportunities between the U.S. and the European Union. The invitational priority is issued in cooperation with the European Union. European institutions participating in any consortium proposal responding to the invitational priority may apply to the European Commission Directorate Generale for Education, Training, and Youth for additional funding under a separate European competition.

Priority**Invitational Priority**

The Secretary is particularly interested in applications that meet the

following invitational priority.

However, an application that meets this invitational priority does not receive competitive or absolute preference over other applications (34 CFR 75.105(c)(1)).

Invitational Priority: Projects that support consortia of institutions of higher education that promote institutional cooperation and student mobility between the United States and the member states of the European Union.

Methods for Applying Selection Criteria

The Secretary gives equal weight to the listed criteria. Within each of the criteria, the Secretary gives equal weight to each of the factors.

Selection Criteria

In evaluating applications for grants under this program competition, the Secretary uses the following selection criteria chosen from those listed in 34 CFR 75.210.

1. *The significance of the proposed project, as determined by—*

a. The significance of the problem or issue to be addressed by the proposed project;

b. The extent to which the proposed project involves the development or demonstration of promising new strategies that build on, or are alternatives to, existing strategies;

c. The importance or magnitude of the results or outcomes likely to be attained by the proposed project, especially improvements in teaching and student achievement;

d. The potential replicability of the proposed project or strategies, including, as appropriate, the potential for implementation in a variety of settings; and

e. The likely utility of the products (such as information, materials, processes, or techniques) that will result from the proposed project, including the potential for their being used in a variety of other settings.

2. *The quality of the design of the proposed project, as determined by—*

a. The extent to which the design of the proposed project is appropriate to, and will successfully address, the needs of the target population or other identified needs;

b. The extent to which the goals, objectives, and outcomes to be achieved by the proposed project are clearly specified and measurable; and

c. The quality of the proposed demonstration design and procedures for documenting project activities and results.

3. *The adequacy of resources, as determined by—*

a. The extent to which the costs are reasonable in relation to the objectives, design, and potential significance of the proposed project;

b. The relevance and demonstrated commitment of each partner in the proposed project to the implementation and success of the project;

c. The potential for continued support of the project after Federal funding ends, including, as appropriate, the demonstrated commitment of appropriate entities to such support.

FOR APPLICATIONS OR INFORMATION

CONTACT: Fund for the Improvement of Postsecondary Education (FIPSE), U.S. Department of Education, 7th & D Streets, S.W., Room 3100, ROB-3, Washington, D.C. 20202-5175. You may also request application forms by calling 732-544-2504 (fax on demand), or application guidelines by calling 202-358-3041 (voice mail) or submitting the name of the competition and your name and postal address to FIPSE@ED.GOV (e-mail). Applications are also listed on the FIPSE Web Site <<http://www.ed.gov/offices/OPE/FIPSE>>. For additional program information call Beverly Baker at the FIPSE office (202-708-5750) between the hours of 8 a.m. and 5 p.m., Eastern time, Monday through Friday. Individuals who use a telecommunications device for the deaf (TDD) may call the Federal Information Relay Service (FIRS) at 1-800-877-8339 between 8 a.m. and 8 p.m., Eastern time, Monday through Friday.

Individuals with disabilities may obtain this document in an alternate format (e.g., Braille, large print, audiotape, or computer diskette) on request to the contact person listed in the preceding paragraph.

Individuals with disabilities may obtain a copy of the application package in an alternate format, also, by contacting that person. However, the Department is not able to reproduce in an alternate format the standard forms included in the application package.

Electronic Access to This Document

Anyone may view this document, as well as all other Department of Education documents published in the **Federal Register**, in text or portable document format (pdf) on the World Wide Web at either of the following sites:

<http://ocfo.ed.gov/fedreg.htm>
<http://www.ed.gov/news.html>

To use the pdf you must have the Adobe Acrobat Reader Program with Search, which is available free at either of the previous sites. If you have questions about using the pdf, call the U.S. Government Printing Office toll free at 1-888-293-6498.

Anyone may also view these documents in text copy only on an electronic bulletin board of the Department. Telephone: (202) 219-1511

or, toll free, 1-800-222-4922. The documents are located under Option C—Files/Announcements, Bulletins, and Press Releases.

Note: The official version of a document is the document published in the **Federal Register**.

Program Authority: 20 U.S.C. 1135-1135a-3.

Dated: January 29, 1998.

David A. Longanecker,
Assistant Secretary for Postsecondary Education.

[FR Doc. 98-3282 Filed 2-9-98; 8:45 am]

BILLING CODE 4000-01-P



Federal Register

Tuesday
February 10, 1998

Part VIII

**Environmental
Protection Agency**

**Mobile Source Outreach Assistance
Competition; Fiscal Year 1998:
Solicitation Notice**

ENVIRONMENTAL PROTECTION AGENCY

[FRL-5957-5]

Mobile Source Outreach Assistance Competition; Fiscal Year 1998: Solicitation Notice

AGENCY: Environmental Protection Agency.

ACTION: Notice.

SUMMARY: Today's notice announces the availability of funding and solicits proposals from state, local and tribal air pollution control agencies for mobile source-related outreach projects. The funding will be allocated by EPA's Office of Mobile Sources through the competitive process described in this notice.

DATES: The deadline for submitting final proposals is March 26, 1998. In addition, to allow for efficient management of the competitive process, OMS is requesting that agencies submit an Intent to Apply by February 20, 1998. (Instructions for submitting final proposals and Intents to Apply are found in Section X. below).

ADDRESSES: This proposal can also be found on the Office of Mobile Sources Web Page: "www.epa.gov/omswwww/" click on "What's New?" Addresses for submitting proposals can be found in Section X. below.

FOR FURTHER INFORMATION CONTACT: Susan Bullard, Director of Outreach and Communication, US EPA Office of Mobile Sources, 401 M. Street SW, (mail code 6401), Washington, DC 20460. Telephone (202) 260-2614; Fax (202) 260-6011; or email "bullard.susan@epamail.epa.gov".

Contents by Section

- Section I. Overview and Deadlines
- Section II. Eligible Organizations
- Section III. Funding Issues
- Section IV. Program Emphasis
- Section V. Criteria
- Section VI. Evaluation and Selection
- Section VII. Proposals
- Section VIII. Current OMS-Funded Outreach Projects
- Section IX. Other Items of Interest
- Section X. How to Apply
- Section XI. OMS Program Contact

Section I. Overview and Deadlines

A. Overview

Over the past year, OMS has entered into agreements and established partnerships with a number of organizations to (1) provide national support for community-based mobile source public education efforts and, (2) encourage responsible choices for organizational and individual actions

through public education. Current outreach projects funded through OMS (listed in Section VIII(U) below) emphasize transportation choices; education of vehicle owners and drivers of the future; car care and the role of the automotive technician; and, related projects such as ozone mapping and small engines. EPA's Office of Mobile Sources has set aside funds from the State and Tribal Assistance Grants (STAG) funds to provide support to community-based mobile source-related outreach projects. This notice solicits proposals for outreach projects which directly support state and local air management organizations in their efforts to improve air quality from mobile sources. Proposals will be accepted from state, local, tribal and multi-state air management agencies which are identified under Section 302(b) of the Clean Air Act.

Interested persons call also obtain copies of this solicitation at no charge by accessing "What's New?" on the OMS Website, "http://www.epa.gov/omswwww.."

B. What Are the Deadlines for This Competition?

In order to efficiently manage the selection process, the Office of Mobile Sources requests that an informal "Intent to Apply" be submitted by February 20, 1998. An "Intent to Apply" simply states in the form of e-mail, phone, or fax that your organization intends to submit a proposal to be received by the deadline. *The deadline for submitting completed proposals (original and six copies) is March 26, 1998.*

Section II. Eligible Organizations

C. Who Is Eligible To Submit Proposals?

According to funding policies associated with the State and Tribal Assistance Grants regulations (STAG funds), proposals can be accepted only from air pollution control agencies as defined under Section 302(b) of the Clean Air Act (for projects to be undertaken will have replicability to other communities nationally), as well as multi-state organizations supporting Section 302(b) agencies and collaborations of air pollution control agencies.

Interested air management organizations which are not air pollution control agencies as defined under Section 302(b) of the Clean Air Act are encouraged to create partnerships with eligible organizations. In that situation, the eligible organization would be required to

submit the final proposal and serve as the funding recipient if selected.

Section III. Funding Issues

D. What Is the Amount of Available Funding?

Approximately \$575K

E. How Will Funds Be Allocated?

The competition process will be managed by OMS and selected cooperative agreements will be awarded by EPA's Regional offices and funded through either Section 103 (multi-state organizations) or Section 105 authority (state and local air pollution control agencies.)

F. How Many Agreements Will Be Awarded?

Approximately six agreements will be awarded, none to exceed \$150,000. The total dollar amount of the final awards must be within available funding.

G. Are Matching Funds Required?

Possibly. Clean Air Act Section 105 mandates that eligible agencies provide matching funds of at least 40%. Therefore, if an air pollution control agency submits a proposal for which they do not already have sufficient matching funds, they must include a statement in their proposal indicating that the match could be met if their proposal is selected. Organizations unable to meet a required match must be considered ineligible. (This requirement does not apply to multi state organizations.) Organizations which are unclear as to their matching status are recommended to contact their EPA Regional Grant Coordinator.

H. Can Funding Be Used To Acquire Services or Fund Partnerships?

Yes—subgrants and other procurement services are allowed. Because the method used to fund subgrants is not a federal matter, procedures governing your organization's procurement practices must be followed. Please indicate any intent to enter into such agreements in the proposal.

Section IV. Program Emphasis

I. Program Emphasis

- Voluntary Measures
- Transportation choices
- Car care (testing, repair, maintenance)
- Environmental education for youth.
 - Other mobile source issues (including but not limited to: on-board diagnostics, diesel, particulate matter, heavy duty engines; nonroad engines; ozone mapping/forecasting)

Section V. Criteria**J. Primary Criteria**

- Addresses environmental goals of improved air quality from mobile sources
- Presents a strong public health message
- Demonstrates national or regional applicability
- Demonstrates effectiveness of delivery mechanism to reach targeted audience
- Exhibits clearly—stated and appropriate levels of funding
- Includes effective measurement/evaluation methods
- Reflects the potential for sustainability

K. Other Factors To Be Considered

- Innovation in public awareness
- Effectiveness of collaborative activities and partnerships with other stakeholders needed to effectively develop or implement the project
 - Integration with existing programs
 - Willingness to coordinate with other OMS-funded outreach activities

L. Presentation Criteria

- Completeness
- Action-oriented
- Clearly-stated objectives
- Reasonable time frames

Section VI. Evaluation and Selection**M. The Evaluation Team Is Chosen to Address a Full Range of Mobile Source and EPA Program Expertise.**

In addition, each EPA Regional office is given the opportunity to review those proposals generated by eligible organizations within that Region. The Evaluation Team will base its evaluation on the criteria referenced in this Request for Proposal. Completed evaluations will be referred to a Selection Committee representing OMS senior managers and Regional representatives who are responsible for final selection. To ensure equity and objectivity throughout the process, the OMS Program Contact (listed below) and staff who facilitate the process and participate in pre-application assistance, do not serve as members of either the Evaluation Team or the Selection Committee.

Section VII. Proposals**N. What Must Be Included in the Proposal?**

Proposals should be approximately 5–7 pages in length and must include:

- (1) A brief statement that candidate organization is defined as an air pollution control agency under Section 302(b) of the Clean Air Act

(2) A statement that any required match could be met

(3) A concise statement of project background/objectives highlighting relationship to improving air quality from mobile sources

(4) A detailed project summary—description of specific actions to be undertaken, including estimated time line for each task

(5) Associated work products to be developed

(6) Explanation of project benefits

(7) Detailed explanation of how project outcomes will be designed for replication in other communities

(8) A detailed budget estimate (clearly explain how funds will be used, including estimated cost for each task)

(9) Projected time frame for project from initiation through completion

(10) Project contact(s) (provide name, organization, phone, fax, and e-mail where available)

(11) Other relevant information to assist in the selection process

O. Will 2-Year Proposals Be Considered?

Yes. If a proposal with a 2-year project period is submitted, OMS requires that the budget and cost estimate be designed to indicate what will be accomplished in each of the first and second years.

P. May an Eligible Organization Submit More Than One Proposal?

An organization may submit more than one proposal only if the proposals are for different projects.

Q. May an Eligible Organization Resubmit a Proposal Which Was Submitted to the Mobile Source Outreach Assistance Competition in 1997, but Was Not Selected?

Yes. The proposals received by OMS in 1997 were generally of very high quality. Clearly, all proposals of merit could not be selected due to finite resources available.

R. May an Eligible Organization Submit a Proposal for This Fiscal Year, Even if It Was Awarded Funding Under This Program in Its First Year?

Yes. Applicants awarded funding in last year's competition may submit new proposals to fund a different project. This program is designed to provide seed money to initiate new projects or advance existing projects that are new in some way (e.g. new audiences, new locations, new approaches.)

S. Does This Funding Expire at the End of FY 98?

No. The statute states that State and Tribal Assistance Grants (STAG) for

environmental programs remain available until expended.

T. Ineligible Proposals

Proposals will be determined to be ineligible if: (1) The candidate organization is not currently defined as an air pollution control agency under Section 302(b) of the Clean Air Act; (2) a required match cannot be met; (3) the proposal is incomplete; or (4) the proposal is postmarked after the deadline.

Section VIII. Current OMS-Funded Outreach Projects**U. OMS/Section 105-Funded Mobile Source Outreach Projects Currently Underway**

To minimize the possibility for duplication of effort, leverage resources and maximize the possibility for networking as proposals are developed, the following provides brief sketches of mobile source-related outreach projects currently funded through the Office of Mobile Sources.

The Seven Projects Selected Through the FY 97 Mobile Source Outreach Assistance Competition Are Indicated With (* * *)

Other projects listed are funded from the Office of Mobile Sources program funds. Contacts are provided for further information. Projects are categorized as for clarity.

Transportation Choices

"A Tour of the Urban Environment" (* * *). Illinois EPA and the Chicago Museum of Science and Industry, Contact: Betsy Tracey, 217/782-0408

The project is designed to:

- enhance the air quality and mobile source component of "A Tour of the Urban Environment"—a permanent environmental science exhibit at the Chicago Museum of Science and Industry
- present basic science, describe health effects, explain citizen role in contributing to mobile source emissions, explain "calls to action" such as "Ozone Action Days," foster critical problem-solving and decision-making skills
- create "real" meteorological station measuring actual ambient conditions outside the Museum, an interactive learning device (computer with CD Rom) and supporting materials to illustrate the relationship between meteorology and ozone. The user can become an ozone forecaster
- projected to open on Earth Day, 1998

"Chattanooga Lifestyle Campaign: Improving Chattanooga's Air Quality Through Voluntary Citizen Transportation Choices" (* * *). Chattanooga-Hamilton County Air Pollution Control Board, Contact: Angela Turner, 423/867-4321

Working with the Global Action Plan (GAP), the project goal will be to enhance the mobile source component of Chattanooga's Household EcoTeam Project. The project includes:

- 4-month tracking of specific actions to reduce auto emissions through transportation choices in 50 households
- peer support and handbook to support family involvement
- follow up research to determine sustainability of new transportation practices
- two-part national technology transfer—invitational conference for local, state and federal air quality managers after demonstration period; broad-based outreach through presentations at meetings and conferences

EPA/DOT Transportation/Air Quality Initiative. Contacts: Kathy Daniel (DOT/FHWA), 202/366-6276, Joann Jackson-Stephens (EPA/OMS), 734/668-4276, Abbe Marner (DOT/FTA), 202/366-4317

This collaborative effort is:

- community-based with support from federal agencies to increase public awareness of impact of travel behavior on air quality, encourage the public to make informed transportation choices, and increase the driving public's awareness of alternative modes of transportation
- building on results from 3 pilot community sites—Dover, DE; Milwaukee, WI; and San Francisco, CA
- designed to include coalition-building at the national and local levels, environmental education for youth, production of consistent, effective informational materials for public and media, and evaluation of changes in public awareness and actions
- nationally available to additional sites nationally in Spring, 1999

"Youth VMT Initiative: Community-Based Solutions to Community-Defined Problems". Academy for Educational Development (AED), Contacts: Rick Bossi, 202/884-8898

The purpose of this youth-based program, which begins with 3 pilot sites in Kansas City, Boston, and Tampa is to:

- create a replicable and sustainable program for involving youth and

- families in reducing growth in vehicle miles traveled (VMT)
- enable youth to communicate about travel choices, solve problems and make sound travel decisions to minimize VMT
- share successful practices, lessons learned and tools developed in the pilot sites with other communities
- serve as a blueprint for communities interested in including a youth component in efforts to reduce emissions from mobile sources

"Interactive Information Kiosk" (* * *). Ventura County Air Pollution Control Board, Contact: Barbara Page, 805/645-1415

This initiative will:

- develop a stand-alone bilingual interactive information kiosk for the public focusing on transportation-related air quality issues with content which reflects national, state and local issues
- produce products including a prototype kiosk (providing other air quality management agencies with 60-70% of actual programming needed to produce a similar kiosk for their citizens—video, graphics, animation) and an instructional handbook
- be delivered in Summer, 1998

Youth Education

"I.D.L.E. in Dade" (* * *). Dade County Department of Environmental Resources Management, Contact: Jenny May, 305/372-6495

The program will:

- educate new drivers on the air quality impacts of driving, use of alternative fuels and transportation choices
- encourage responsible maintenance and driving practices
- teach critical-thinking, problem-solving, and decision-making skills through educational videos, informational handouts, creative hands-on demonstrations and design contests

"Public Education and Outreach on Mobile Source Emissions and Driving Smart". Environmental Health Center of the National Safety Council, Contact: Nyki Brandon-Palermo, 202/974-2484

Networking and coordinating with other similar projects across the country, this effort will:

- develop a driver education curriculum module for new drivers linking benefits of responsible maintenance to responsible driving for use in 15,000+ public and private driver education programs nationwide

Driver Education Pilot. NESCAUM, Contact: Natoschia Scruggs, 617/367-8540

This effort will:

- pilot the driver education curriculum module (developed by the Environmental Health Center—see above) in several locations in the northeast

Car Care and the Role of the Auto Technician

"Car Care for Clean Air" Contacts: Mia Zmud, Weber State University, 801/536-4095

This pilot project is designed to:

- raise public awareness of ways in which automotive service affects air quality
- create coalitions to identify ways to improve vehicle maintenance practices—elevating the number, skill sets, performance and image of vehicle maintenance technicians
- encourage environmentally-sound transportation choices in anticipation of 2002 Olympics and beyond

"Air Pollution, Motor Vehicles and Public Health." American Lung Association (ALA), Contact: Katherine Pruitt, 202/785-3355

Mini-grants, provided to 17 local lung associations (through ALA competitive process) for public education efforts, will:

- send a strong public health message focused on children and asthma designed to raise public awareness of air quality and the impact of mobile sources
- be in place for ozone season, 1998

"The Air Repair Communications Project" (* * *). Missouri Department of Natural Resources, Contact: Kerry Cordray, 573-751-4817

A bi-state effort in partnership with the American Lung Association of Eastern Missouri, the "Air Repair Communications Project" will:

- focus on enhanced inspection and maintenance
- create replicable materials including media kits, psas, exhibits, articles for newsletters, brochure to educate on enhanced I/M, theater screen slides, video to be distributed through Blockbuster;
- undertake activities including car care clinics, community presentations, training and materials development for transportation management associations, participation at commuter fairs, open houses for public information exchange; make I/M program information available through posting on the WWW and other outreach tools.

Related Projects

"Integrate the Televised Ozone Map with Mobile Source Outreach Initiatives" (* * *). NESCAUM/MARAMA/OTC Collaboration, Contact: Natoschia Scruggs, NESCAUM, 617/367-8540

This project will:

- expand the scope of the animated ozone map to 14 states represented by the NESCAUM, MARAMA, and the OTC
- encourage region-wide distribution and use of the map, conduct public outreach to inform and motivate voluntary mobile source ozone abatement actions, and development of outreach materials for meteorologists and the public
- provide technical assistance to other regions of the country interested in the benefits of ozone mapping and forecasting, through creation of a web site and other outreach activities

Ozone and Particulate Matter Outreach. STAPPA/ALAPCO, Contact: Gail Lewkowicz, 202/624-7864

STAPPA/ALAPCO will develop dynamic education and outreach materials to help state and local air agencies communicate the ozone and PM decisions and potential implications to elected officials, the media and the public. The project will:

- produce an informational video on PM 2.5 and disseminate to every state and local air agency. The video will be designed to educate important constituents including

state and local elected officials, civic and business groups and high school and college students—available in January 1998

- develop a modular PM implementation tool kit providing a variety of materials including communication tools to assist state and local agencies in explaining how the new PM fine standard will be implemented as well as potential implications

"Cash for Clippers" (* * *). Maryland Department of the Environment, Contact: Anna Nardolillo, 410/631-3240

This program will:

- educate consumers about pollution prevention, ground-level ozone, MDE's forecasting program, and the impact of lawn and garden equipment
- offer rebates toward purchase of non-gasoline powered lawn mowers
- develop economic incentives to prevent pollution, foster creativity and innovation within the private and public sectors

Section IX. Other Items of Interest

V. Is There Other Information I Should Have?

Yes.

- Submission of a proposal does not guarantee funding.
- Only those organizations selected will be required to submit a complete "Application for Federal Assistance and Budget Information (SF 424 and SF 424A) to the appropriate EPA Regional Office."

Section X. How to Apply

X. How Do I Apply?

Completed proposals (original + 6) should be sent via regular mail to:

Susan Bullard, Director of Outreach and Communication, US EPA Office of Mobile Sources, Mail Code 6401, 401 M Street SW, Washington, DC 20460

Note: Proposals may be faxed, but must be followed by a hard copy original and 6 copies.

Proposals to be sent through express mail must be sent to the following address:

Susan Bullard, Director of Outreach and Communication, US EPA Office of Mobile Sources, Room W737, 401 M Street, SW, Washington, DC. 20460, (202) 260-2614, (202) 260-7645 (backup number for expressed proposals only)

Deadline for Submitting Final Proposals—March 26, 1998.

Section XI. OMS Program Contact

Susan Bullard, Director of Outreach and Communication, EPA Office of Mobile Sources, 401 M Street, SW (Mail Code 6401), Washington, DC 20460, (Phone) 202/260-2614, (Fax) 202/260-6011, "bullard.susan@epamail.epa.gov"

Dated: January 27, 1998.

Richard D. Wilson,
Program Official.

[FR Doc. 98-3317 Filed 2-9-98; 8:45 am]

BILLING CODE 6560-50-U



Reader Aids

Federal Register

Vol. 63, No. 27

Tuesday, February 10, 1998

CUSTOMER SERVICE AND INFORMATION

Federal Register/Code of Federal Regulations	
General Information, indexes and other finding aids	202-523-5227
E-mail	info@fedreg.nara.gov
Laws	
For additional information	523-5227
Presidential Documents	
Executive orders and proclamations	523-5227
The United States Government Manual	523-5227
Other Services	
Electronic and on-line services (voice)	523-4534
Privacy Act Compilation	523-3187
TDD for the hearing impaired	523-5229

ELECTRONIC BULLETIN BOARD

Free **Electronic Bulletin Board** service for Public Law numbers, Federal Register finding aids, and list of documents on public inspection. 202-275-0920

FAX-ON-DEMAND

You may access our Fax-On-Demand service with a fax machine. There is no charge for the service except for long distance telephone charges the user may incur. The list of documents on public inspection and the daily Federal Register's table of contents are available. The document numbers are 7050-Public Inspection list and 7051-Table of Contents list. The public inspection list is updated immediately for documents filed on an emergency basis.

NOTE: YOU WILL ONLY GET A LISTING OF DOCUMENTS ON FILE. Documents on public inspection may be viewed and copied in our office located at 800 North Capitol Street, NW., Suite 700. The Fax-On-Demand telephone number is: 301-713-6905

FEDERAL REGISTER PAGES AND DATES, FEBRUARY

5223-5446.....	2
5447-5720.....	3
5721-5858.....	4
5859-6044.....	5
6045-6468.....	6
6469-6626.....	9
6627-6838.....	10

CFR PARTS AFFECTED DURING FEBRUARY

At the end of each month, the Office of the Federal Register publishes separately a List of CFR Sections Affected (LSA), which lists parts and sections affected by documents published since the revision date of each title.

3 CFR		5873, 5875, 5876, 5878, 5879, 5881, 6064, 6066, 6069, 6629, 6633, 6635, 6636, 6638, 6639, 6642
Proclamations:		
7066.....	5717	
7067.....	5719	71.....5228, 5229, 5230, 5231, 5232, 6001
13073.....	6467	95.....5882
Executive Orders:		97.....5447, 5886
Administrative Orders:		
No. 98-12 of January		
28, 1998.....	6469	Proposed Rules:
No. 98-13 of January		39.....5318, 5320, 5322, 5324, 5325, 5327, 5763, 5765, 5766, 5898, 5900, 5902, 5904, 6499, 6501, 6682, 6683, 6685, 6689
30, 1998.....	5857	71.....6818
5 CFR		135.....6826
532.....	6471	259.....5329
7 CFR		
6.....	5223	15 CFR
1948.....	6045	303.....5887
1951.....	6045, 6627	740.....5448
4274.....	6045	742.....5448
Proposed Rules:		
205.....	5285, 6498	17 CFR
723.....	5285	11.....5232
911.....	6679	211.....6474
915.....	6679	228.....6470
958.....	5472	229.....6470
980.....	5472	230.....6470
4284.....	5474	239.....6470
8 CFR		274.....6470
Proposed Rules:		Proposed Rules:
274a.....	5287	1.....6112
299.....	5287	33.....6112
9 CFR		
93.....	6063	18 CFR
10 CFR		157.....6476
Proposed Rules:		388.....5452
2.....	5315	430.....6477
12 CFR		
9.....	6472	19 CFR
226.....	6474	Proposed Rules:
614.....	5721	10.....5329
615.....	5223	12.....5329
627.....	5721	18.....5329
791.....	5859	24.....5329
Proposed Rules:		111.....5329
226.....	6112	113.....5329
708.....	5898	114.....5329
937.....	5315	114.....5329
13 CFR		125.....5329
107.....	5859	134.....5329
Proposed Rules:		145.....5329
121.....	5223, 5480	162.....5329
14 CFR		171.....5329
21.....	6808	172.....5329
39.....	5224, 5225, 5226, 5225,	

520.....5254
 522.....6643
 524.....5254
 529.....6643
 558.....5254, 6644
 601.....5233
 807.....5233
 812.....5233
 814.....5233
 860.....5233
Proposed Rules:
 601.....5338
22 CFR
 51.....6478
 72.....6479
 92.....6479
24 CFR
 200.....5422
Proposed Rules:
 200.....6798
 203.....5660
26 CFR
 1.....5834
27 CFR
 53.....5727
29 CFR
 24.....6614
 1200.....6644
Proposed Rules:
 1910.....5905
30 CFR
 924.....6796
 946.....5888
Proposed Rules:
 206.....6113
 904.....6286
31 CFR
 203.....5644
Proposed Rules:
 210.....5426, 6001
33 CFR
 80.....5728

82.....5728
 84.....5728
 87.....5728
 88.....5728
 90.....5728
 100.....5455, 6071
 117.....5456, 5457, 5458, 6073
 160.....5458
 165.....6071
Proposed Rules:
 Ch. I.....5767
 110.....6141
 165.....6142
 167.....6502
36 CFR
 1193.....5608
37 CFR
 1.....5732
39 CFR
 20.....5458
 262.....6480
 265.....6480
40 CFR
 50.....6032
 51.....6483, 6645
 52.....5268, 5269, 5460, 6073,
 6483, 6484, 6487, 6489,
 6491, 6645, 6646, 6647,
 6648, 6649, 6650, 6651,
 6653, 6659, 6664
 60.....5891, 6493
 61.....5891, 6493
 62.....6664
 70.....6494
 73.....5734
 81.....6664
 82.....6008
 180.....5735, 5737, 6495, 6665
 186.....6665
 244.....5739
 245.....5739
 271.....6666
 281.....6667
 372.....6668
 721.....5740, 6496, 6668

Proposed Rules:
 52.....5339, 5484, 5489, 5834,
 6143, 6504, 6505, 6690,
 6691
 62.....5834
 63.....6288
 73.....5773
 82.....5460, 5906
 144.....5907
 146.....5907
 180.....5907
 186.....5907
 300.....6507
 372.....6691
 444.....6392
 445.....6426
 799.....5915
41 CFR
 101-46.....5892
 302-10.....5742
43 CFR
 8372.....6075
 8560.....6075
44 CFR
 206.....5895
46 CFR
Proposed Rules:
 Ch. I.....5767
47 CFR
 2.....6669
 25.....6496
 43.....5743
 63.....5743
 64.....5743
 73.....5464, 5743, 5744, 6077,
 6078, 6079
 101.....6079
Proposed Rules:
 73.....6144, 6698, 6699
48 CFR
 225.....5744
 246.....6109
 252.....5744

932.....5272
 970.....5272
 1515.....6675
 1552.....6675, 6676
Proposed Rules:
 4.....5714
 7.....5714
 8.....5714
 15.....5714
 16.....5714
 17.....5714
 22.....5714
 27.....5714
 28.....5714
 31.....5714
 32.....5714
 35.....5714
 42.....5714
 43.....5714
 44.....5714
 45.....5714
 49.....5714
 51.....5714
 52.....5714
 53.....5714
49 CFR
 192.....5464
 195.....6677
 572.....5746
Proposed Rules:
 192.....5339
 193.....5918
 195.....5339, 5918
 531.....5774
 571.....6144
50 CFR
 216.....5277
 229.....5748
 622.....6109
 679.....5836, 6110, 6111
Proposed Rules:
 18.....5340
 622.....6004
 648.....6510, 6699, 6701
 679.....5777

REMINDERS

The items in this list were editorially compiled as an aid to Federal Register users. Inclusion or exclusion from this list has no legal significance.

RULES GOING INTO EFFECT FEBRUARY 10, 1998**AGRICULTURE DEPARTMENT****Animal and Plant Health Inspection Service**

Exportation and importation of animals and animal products:

Horses from Mexico; quarantine requirements; published 1-26-98

ENVIRONMENTAL PROTECTION AGENCY**Acquisition regulations:**

Information Resources Management policies; electronic access; correction; published 2-10-98

Profit or fee calculations; correction; published 2-10-98

Air programs; approval and promulgation; State plans for designated facilities and pollutants:

New Mexico et al.; correction; published 2-10-98

Air quality implementation plans:

Preparation, adoption, and submittal—
Vehicle inspection and maintenance program

requirements; motorist compliance enforcement mechanisms for pre-existing programs; correction; published 2-10-98

Air quality implementation plans; approval and promulgation; various States:

Minnesota; correction; published 2-10-98

Missouri; correction; published 2-10-98

Air quality implementation plans; approval and promulgation; various States, etc.:

Ohio, et al.; correction; published 2-10-98

Air quality implementation plans; approval and promulgation; various States:

Ohio; correction; published 2-10-98

Washington; correction; published 2-10-98

Hazardous waste program authorizations:

Alabama; correction; published 2-10-98

Hazardous wastes:

State underground storage tank program approvals—

West Virginia; correction; published 2-10-98

Pesticides; tolerances in food, animal feeds, and raw agricultural commodities:

Thiodicarb; correction; published 2-10-98

Superfund program:

Toxic chemical release reporting; community right-to-know—

Hydrochloric acid; correction; published 2-10-98

Toxic substances:

Significant new uses—

Cyclohexanecarbonitrile, 1,3,3-trimethyl-5-oxo; correction; published 2-10-98

HEALTH AND HUMAN SERVICES DEPARTMENT**Food and Drug Administration**

Animal drugs, feeds, and related products:

New drug applications—
Salinomycin; published 2-10-98

Sponsor name and address changes—

Phoenix Scientific, Inc.; published 2-10-98

NATIONAL MEDIATION BOARD

Conflict of interests; CFR part removed; published 2-10-98

SECURITIES AND EXCHANGE COMMISSION

Securities and investment companies:

Money market funds; rules and forms; technical amendments; published 12-9-97

COMMENTS DUE NEXT WEEK**LIST OF PUBLIC LAWS**

This is the first in a continuing list of public bills from the current session of Congress

which have become Federal laws. It may be used in conjunction with "PLUS" (Public Laws Update Service) on 202-523-6641. This list is also available online at <http://www.nara.gov/nara/fedreg/fedreg.html>.

The text of laws is not published in the **Federal Register** but may be ordered in "slip law" (individual pamphlet) form from the Superintendent of Documents, U.S. Government Printing Office, Washington, DC 20402 (phone, 202-512-1808). The text will also be made available on the Internet from GPO Access at http://www.access.gpo.gov/su_docs/. Some laws may not yet be available.

S. 1575/P.L. 105-154

To rename the Washington National Airport located in the District of Columbia and Virginia as the "Ronald Reagan Washington National Airport". (Feb. 6, 1998; 112 Stat. 3)

Public Laws Electronic Notification Service

Free electronic mail notification of newly enacted Public Laws is now available. To subscribe, send E-mail to LISTPROC@ETC.FED.GOV with the message:
Subscribe Publaws-L (your) Firstname Lastname.

Now Available Online

through

GPO Access

A Service of the U.S. Government Printing Office

Federal Register

Updated Daily by 6 a.m. ET

**Easy, Convenient,
FREE**

Free public connections to the online Federal Register are available through the GPO Access service.

To connect over the World Wide Web, go to the Superintendent of Documents' homepage at http://www.access.gpo.gov/su_docs/

To connect using telnet, open swais.access.gpo.gov and login as guest (no password required).

To dial directly, use communications software and modem to call (202) 512-1661; type swais, then login as guest (no password required).



You may also connect using local WAIS client software. For further information, contact the GPO Access User Support Team:

Voice: (202) 512-1530 (7 a.m. to 5 p.m. Eastern time).

Fax: (202) 512-1262 (24 hours a day, 7 days a week).

Internet E-Mail: gpoaccess@gpo.gov

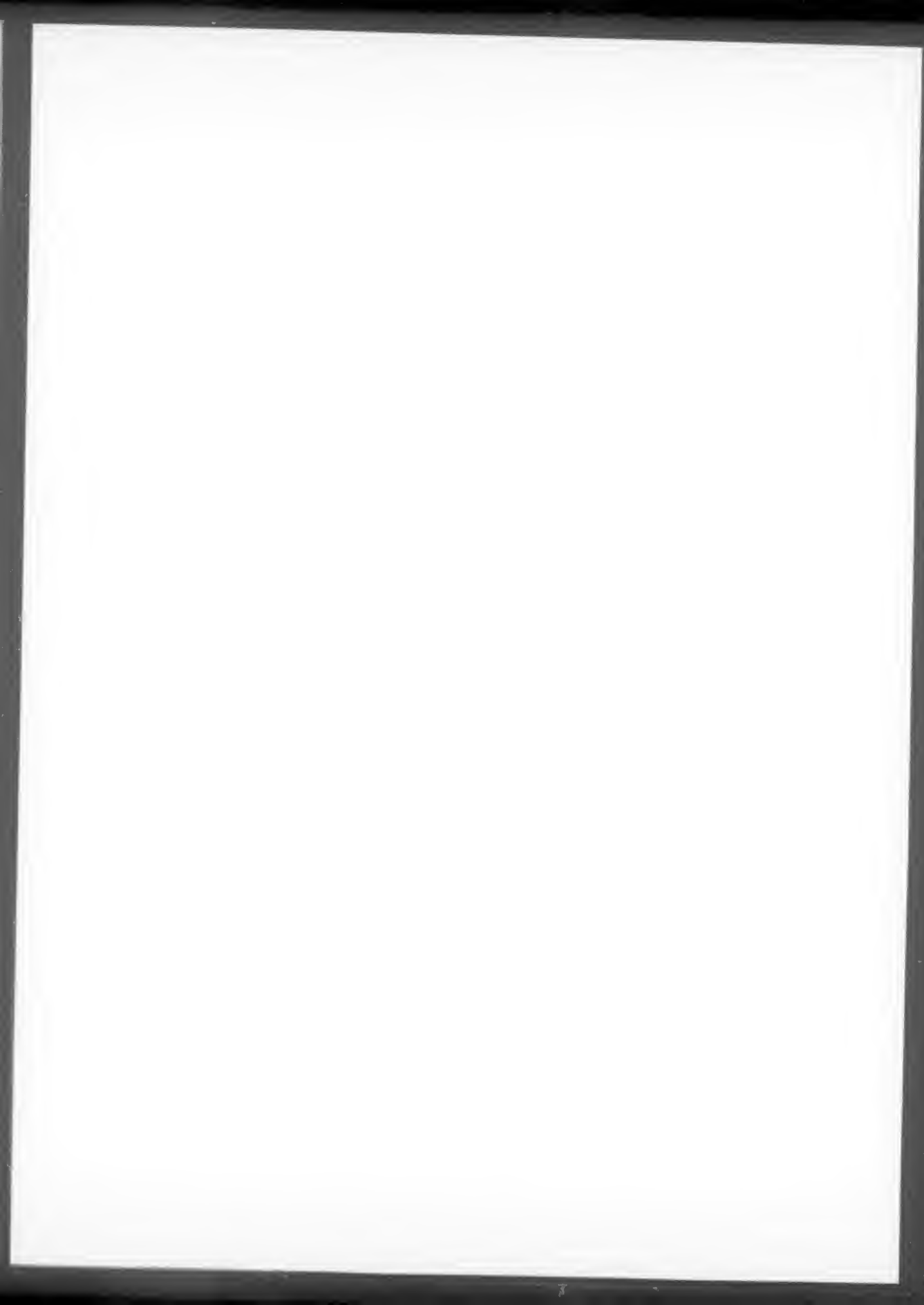



Printed on recycled paper

