

Historic, Archive Document

Do not assume content reflects current scientific knowledge, policies, or practices.

BIOLOGY AND BIOLOGICAL CONTROL OF DALMATIAN AND YELLOW TOADFLAX



Sharlene E. Sing, Rosemarie A. De Clerck-Floate, Richard W. Hansen,
Hal Pearce, Carol Bell Randall, Ivo Tošovski, and Sarah M. Ward



The Forest Technology Enterprise Team (FHTET) was created in 1995 by the Deputy Chief for State and Private Forestry, USDA Forest Service, to develop and deliver technologies to protect and improve the health of American forests. This manual was published by FHTET as part of the technology transfer series.

<http://www.fs.fed.us/foresthealth/technology/>

The use of trade, firm, or corporation names in this publication is for the information and convenience of the reader. Such use does not constitute an official endorsement or approval by the U.S. Department of Agriculture or the Forest Service of any product or service to the exclusion of others that may be suitable.



This publication/database reports research involving pesticides. It does not contain recommendations for their use, nor does it imply that the uses discussed here have been registered. All uses of pesticides must be registered by appropriate State and/or Federal agencies before they can be recommended.

CAUTION: Pesticides can be injurious to humans, domestic animals, desirable plants, and fish or other wildlife—if they are not handled or applied properly. Use all pesticides selectively and carefully. Follow recommended practices for the disposal of surplus pesticides and pesticide containers.

How to cite this publication:

Sing, S.E., R. De Clerck-Floate, R.W. Hansen, H. Pearce, C.B. Randall, I. Toševski, and S.M. Ward. 2015. *Biology and Biological Control of Dalmatian and Yellow Toadflax*. USDA Forest Service, Forest Health Technology Enterprise Team, Morgantown, West Virginia. FHTET-2015-03.

Cover photos (L to R): Dalmatian toadflax (K. George Beck & James Sebastian, Colorado State University); yellow toadflax (Linda Wilson, University of Idaho); (Center top to bottom): *Mecinus* spp. adult (Bob Richard, USDA APHIS PPQ); *Calophasia lunula* (Laura Parsons & Mark Schwarzländer, University of Idaho); *Rhinusa linariae* (Bob Richard, USDA APHIS PPQ)

In accordance with Federal civil rights law and U.S. Department of Agriculture (USDA) civil rights regulations and policies, the USDA, its Agencies, offices, and employees, and institutions participating in or administering USDA programs are prohibited from discriminating based on race, color, national origin, religion, sex, gender identity (including gender expression), sexual orientation, disability, age, marital status, family/parental status, income derived from a public assistance program, political beliefs, or reprisal or retaliation for prior civil rights activity, in any program or activity conducted or funded by USDA (not all bases apply to all programs). Remedies and complaint filing deadlines vary by program or incident.

Persons with disabilities who require alternative means of communication for program information (e.g., Braille, large print, audiotope, American Sign Language, etc.) should contact the responsible Agency or USDA's TARGET Center at (202) 720-2600 (voice and TTY) or contact USDA through the Federal Relay Service at (800) 877-8339. Additionally, program information may be made available in languages other than English.

To file a program discrimination complaint, complete the USDA Program Discrimination Complaint Form, AD-3027, found online at http://www.ascr.usda.gov/complaint_filing_cust.html and at any USDA office or write a letter addressed to USDA and provide in the letter all of the information requested in the form. To request a copy of the complaint form, call (866) 632-9992. Submit your completed form or letter to USDA by: (1) mail: U.S. Department of Agriculture, Office of the Assistant Secretary for Civil Rights, 1400 Independence Avenue, SW, Washington, D.C. 20250-9410; (2) fax: (202) 690-7442; or (3) email: program.intake@usda.gov.

USDA is an equal opportunity provider, employer, and lender.



Federal Recycling Program
Printed on recycled paper

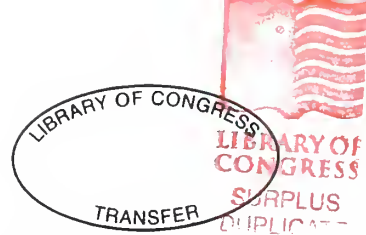

BIOLOGY AND BIOLOGICAL CONTROL OF DALMATION AND YELLOW TOADFLAX

Sharlene E. Sing, Research Entomologist
USDA Forest Service, Rocky Mountain Research Station
1648 South 7th Avenue - MSU Campus, Bozeman, MT
ssing@fs.fed.us

Rosemarie A. De Clerck-Floate, Research Scientist
Weed Biological Control, Lethbridge Research Centre
Agriculture and Agri-Food Canada, Lethbridge, Alberta, Canada
rosemarie.declerck-floate@agr.gc.ca

Richard W. Hansen, Entomologist
USDA Animal and Plant Health Inspection Service
Plant Protection and Quarantine Center for Plant Health Science and Technology
2301 Research Blvd., Suite 108, Fort Collins, CO
Richard.W.Hansen@aphis.usda.gov

Hal Pearce, Natural Resource Specialist
USDA Forest Service, Rocky Mountain Region 2 Invasive Species/Pesticide Use Coordinator
220 East Market Street Meeker, CO
hpearce@fs.fed.us

Carol Bell Randall, Entomologist
USDA Forest Service, Forest Health Protection
2502 E. Sherman Ave, Coeur d'Alene, ID
crandall@fs.fed.us

Ivo Toševski, Research Scientist
Biological Weed Control, CABI, Rue des Grillons 1, CH-2800 Delémont, Switzerland
tosevski_ivo@yahoo.com

Sarah M. Ward, Associate Professor – Plant Genetics
Department of Soil and Crop Sciences
Colorado State University, Fort Collins, CO
sarah.ward@colostate.edu

U.S. Department of Agriculture
National Agricultural Library

JAN 30 2018

Received
Acquisitions and Reference Branch

**Original 2005 version by Linda M. Wilson, Sharlene E. Sing, Gary L. Piper, Richard W. Hansen,
Rosemarie De Clerck-Floate, Daniel K. MacKinnon, and Carol Bell Randall**

Acknowledgments

The content for this second edition was compiled by Rachel L. Winston (MIA Consulting), and the layout was designed by Denise E. Binion, USDA Forest Service-FHTET. Todd Neel (USDA FS) contributed to the discussion on toadflax management options in Chapter 5: An Integrated Toadflax Management Program. We thank Peter G. Mason, Agriculture and Agri-Food Canada, for assistance with the Canadian regulatory information. Linda Wilson (University of Idaho), Mark Schwarzländer (University of Idaho), Daniel K. MacKinnon (Colorado State University), Eric Coombs (Oregon Department of Agriculture), Robert Nowierski (USDA-CSREES), Susan Turner (British Columbia Ministry of Forests), André Gassmann (CABI Bioscience), Ruth Hufbauer (Colorado State University), and Gilbert Wilson (Hazelton, British Columbia) contributed to the first edition of this manual, and many of their contributions have been retained in this revision. We also thank Alec McClay, Timothy Collier, and Joseph McCaffrey for reviewing the first edition of this manual. We would like to thank all of the photographers who granted permission for the use of photos. We also extend our gratitude to Richard Reardon (Forest Service-Forest Health Technology Enterprise Team or FHTET) for producing this guide.

This third edition of the Biology and Biological Control of Toadflaxes has been updated to reflect developments in toadflax biological control since 2009, and expanded to include more information on the history, process, safety, and application of classical biological control of weeds as a component of an integrated weed management program. Since the first edition was published, the taxonomic classification of Dalmatian and yellow toadflax has been revised, and hybrids of Dalmatian and yellow toadflax have been recognized as significant pests. New images have been added to better illustrate identifying characteristics of Dalmatian toadflax, yellow toadflax, and their hybrids. A new section has been included which provides information on how to distinguish plant species commonly confused with Dalmatian, yellow, or hybrid toadflax plants. The second edition reflects updated taxonomic information which divided the toadflax stem mining weevil into two distinct species. New images have been added to help readers more easily differentiate biocontrol agent life stages and biocontrol agent damage to toadflax plants. Biocontrol agent life stages (eggs, larvae, pupae, adults), life cycles, habitat preferences, damage, and current status and availability are described in more detail and in tabular form to facilitate identification and comparison of biocontrol agents' life cycles and damage. The chapter on biocontrol implementation has been expanded to provide the reader with resources for successfully planning and implementing a toadflax biocontrol program. A new chapter on integrated toadflax management has been added which describes other management tools for toadflax (including physical, cultural, and chemical control) and when and how best to integrate biological control with other management tools as part of a toadflax integrated weed management program.

For additional copies of this publication, contact:

Mark Schwarzländer
University of Idaho, PSES Dept.
875 Perimeter Dr., MS 2339
Moscow, ID 83844-2339
208-885-9319
markschw@uidaho.edu

Carol Bell Randall
USDA Forest Service
Forest Health Protection
2502 E. Sherman Ave.
Coeur d'Alene, ID 83814
208-769-3051
crandall@fs.fed.us

Richard Reardon
USDA Forest Service - FHTET
180 Canfield Street
Morgantown, WV 26505
304-285-1566
rreardon@fs.fed.us

TABLE OF CONTENTS

CHAPTER 1: INTRODUCTION	1
Overview	1
Classical Biological Control of Weeds	3
Code of Best Practices for Classical Biological Control of Weeds	5
Biological Control of Toadflaxes	6
Integrated Weed Management	6
Is Biological Control of Toadflax Right for You?	7
About this Manual	8
CHAPTER 2: GETTING TO KNOW TOADFLAXES	11
Classification	11
Dalmatian toadflax.....	12
Classification	12
History	12
Description	12
Biology and Ecology	16
Habitat	16
Distribution	17
Taxonomic issues	17
Commonly Confused Species	19
Yellow toadflax.....	20
Classification	20
History	20
Description	20
Biology and Ecology	24
Habitat	25
Distribution	25
Commonly Confused Species	26
Hybrid toadflax	28
Classification	28
History	28
Description	28
Biology and Ecology	31
Habitat	32
Distribution	32
Toadflax Comparison Table	34
CHAPTER 3: BIOLOGY OF TOADFLAX BIOLOGICAL CONTROL AGENTS	35
Basic Insect Biology.....	35
Toadflax Biological Control Agents.....	36
Beetles	36
Butterflies and Moths	36
<i>Brachypterolus pulicarius</i>	38
Toadflax flower-feeding beetle	
<i>Mecinus janthinus</i> & <i>M. janthiniformis</i>	41
Toadflax stem-mining weevil	
<i>Rhinusa antirrhini</i> & <i>R. neta</i>	45
Toadflax seed weevil	
<i>Rhinusa linariae</i>	49
Toadflax root-galling weevil	
<i>Calophasia lunula</i>	52
Toadflax defoliating moth	
<i>Eteobalea intermediella</i> & <i>E. serratella</i>	54
Toadflax root-boring moths	

Comparison Tables	60
Prospective Toadflax Biological Control Agents	62
CHAPTER 4: ELEMENTS OF A TOADFLAX BIOLOGICAL CONTROL PROGRAM	67
Before You Begin	67
Determining the Scope of the Problem	67
Defining Goals and Objectives	68
Understanding Toadflax Management Options	68
Developing, implementing and Managing a Toadflax Biological Control Program	69
Selecting Biological Control Agent Release Sites	69
Establish goals for your release site.....	69
Determine site characteristics.....	69
Note land use and disturbance factors	70
Survey for presence of biological control agents.....	70
Record ownership and access	70
Choosing the Appropriate Biological Control Agents for Release	71
Biocontrol agent efficacy	74
Biocontrol agent availability	74
Release site characteristics	74
Obtaining and Releasing Toadflax Biological Control Agents	74
Factors to consider when looking for sources of biological control agents.....	75
Collecting Toadflax Biological Control Agents	75
Collection methods.....	76
Tray sampling	76
Hand picking	76
Aspirating.....	76
Sweep netting.....	78
Transferring agent-infested plant material	79
Sorting	79
Collection methods by species	80
Toadflax flower-feeding beetle (<i>Brachypterolus pulicarius</i>).....	80
Toadflax defoliating moth (<i>Calophasia lunula</i>).....	80
Toadflax stem-mining weevils (<i>Mecinus janthinus</i> / <i>M. janthiniformis</i>)	80
Toadflax seed-galling weevil (<i>Rhinusa antirrhini</i>).....	81
Toadflax root-galling weevil (<i>Rhinusa linariae</i>).....	82
Release Containers for Toadflax Biological Control Agents	82
Transporting Toadflax Biological Control Agents.....	83
Keep the containers cool at all times.....	83
Transporting short distances.....	83
Shipping long distances.....	83
Other factors to consider	84
Common packaging mistakes.....	84
Purchasing Toadflax Biological Control Agents.....	85
Releasing Toadflax Biological Control Agents	85
Establish permanent location marker	85
Record geographical coordinates at release point using GPS.....	85
Prepare map.....	85
Complete relevant paperwork at site	86
Set up photo point	86
Release as many agents as possible.....	86
Regulations for the Transfer of Toadflax Biological Control Agents.....	88
Documenting, Monitoring and Evaluation a Biological Control Program	89
The Need for Documentation.....	89
Information Databases.....	89
Monitoring Methods.....	90
Assessing biological control agent populations.....	90
Assessing the status of toadflaxes and co-occurring plants	94
Qualitative vegetation monitoring	94
Quantitative vegetation monitoring	94
Assessing impacts on nontarget plants.....	95
CHAPTER 5 : AN INTEGRATED TOADFLAX MANAGEMENT PROGRAM	97
Introduction	97
Components of Integrated Weed Management Programs	98
Education & Outreach	98

Inventory & Mapping	99
Prevention	99
EDRR	100
Weed Control Activities.....	101
Biological Control	101
Physical Treatment	101
Hand pulling	101
Mowing	102
Tilling	103
Cultural Practices	103
Flooding and Burning	103
Grazing	104
Seeding competitive species	105
Chemical Control	106
 GLOSSARY	 113
 SELECTED REFERENCES	 118
Chapter 1: Introduction.....	118
Chapter 2: Getting to Know Toadflaxes.....	119
Chapter 3: Biology of Toadflaxes Biological Control Agents.....	121
Chapter 4: Elements of a Toadflaxes Biocontrol Program	123
Chapter 5: An Integrated Toadflaxes Management Program	124
 APPENDICES	 127
Appendix I: Troubleshooting Guide: When Things Go Wrong	127
Appendix II: Sample Biological Control Agent Release Form	128
Appendix III: Toadflax Standardized Impact Monitoring Protocol	130
Appendix IV: General Toadflax Biological Control Agent Monitoring Form	134
Appendix V: Toadflax Qualitative Monitoring Form	136
Appendix VI: Toadflax Quantitative Monitoring Form	137

CHAPTER 1: INTRODUCTION

Overview

Dalmatian toadflax, *Linaria dalmatica* (L.) Mill., and yellow toadflax, *Linaria vulgaris* Mill., are exotic weeds of rangeland, grassland, forests, and cropland. Both Dalmatian and yellow toadflax are short-lived perennial forbs that are easily recognized by their yellow snapdragon-like flowers (Figure 1a, 1b). Both species propagate by seed and vegetatively from shoots that arise either from lateral rhizomes (Dalmatian toadflax) or from buds developing on their roots (yellow toadflax). Dalmatian toadflax is native to southeastern Europe while yellow toadflax is considered to be native to Europe and Asia. Hybrids of Dalmatian and yellow toadflax have been found throughout northwestern USA (Figure 1c; hybrids are discussed further in Chapter 2 of this manual). Although several exotic toadflax species have been intentionally or accidentally introduced to North America, these two species and their hybrids are by far the most common and problematic for land managers, and are the focus of this manual. The use of “toadflaxes” throughout this manual encompasses both Dalmatian and yellow toadflax, as well as their hybrids.



Figure 1. Toadflax plants a. Dalmatian toadflax (K. George Beck & James Sebastian, Colorado State University); b. yellow toadflax (Tiffany Wax, Washington State University Extension), c. hybrid toadflax (center) between yellow toadflax (left) and Dalmatian toadflax (right) (Elizabeth Goulet, Cornell University)(a,c bugwood.org)

Dalmatian and yellow toadflax were introduced to North America by the 1800s, likely as ornamental plants, and for use in fabric dye and folk remedies. Both species are now present throughout much of temperate North America. Yellow toadflax occurs in all continental states, all 10 Canadian provinces, and two Canadian territories (Figure 2a), while Dalmatian toadflax is mostly absent in the southeastern USA, Alaska, and the Canadian territories (Figure 2b). The widespread distribution of both species in North America likely began with their sentimental and medicinal value to early settlers, and continued to increase with their popularity as hardy ornamental plants coupled with their highly invasive nature. Exotic toadflaxes continue to be sold as nursery stock in the USA, advertised as “butter and eggs,” “wild snapdragon,” and “Jacob’s ladder”; toadflax seed is sometimes still a component of wildflower seed mixes. The sale of these two species is now illegal in states where they are classified as regulated plants or noxious weeds. Hybrids of yellow and Dalmatian toadflax were recently confirmed to be present in five western states (Figure 2c).



Figure 2. North American distribution maps of a. yellow toadflax; b. Dalmatian toadflax (a,b USDA PLANTS Database, EDDMapS); hybrids of yellow and Dalmatian toadflax (Sarah M. Ward, unpublished data)

Yellow and Dalmatian toadflax are known to thrive particularly well in disturbed, open habitats, especially in areas characterized by dry summers. Dalmatian toadflax is most commonly found on well-drained, coarse-textured soils in disturbed or otherwise degraded sites, such as roadsides, abandoned lots and fields, gravel pits, forest or pasture clearings, overgrazed or deteriorated rangelands, and along railroad tracks. Because Dalmatian and yellow toadflax compete aggressively for light, water, and nutrients, both toadflaxes can displace native and/or more desirable plant species in natural areas. Although yellow toadflax is typically associated with more moist and fertile sites, it can invade higher elevations (e.g. alpine meadows), and unlike Dalmatian toadflax, affects cropland. Consequently, yellow toadflax is a serious management concern on both cultivated and uncultivated sites. Large yellow toadflax infestations have caused economic injury to crops as diverse as grain, oil seed, berries/small fruits, and oil mint. Economic injury associated with hybrid toadflax infestations is thus far unknown.

Successful management of toadflaxes is an intensive process due to their robust root systems and abundant seed production. Hand-pulling small, individual toadflax plants can be an effective control strategy if repeated for several years. Pulling large plants is more difficult and may exacerbate the problem if viable root fragments are left behind to generate new shoots. Repeated mowing can reduce toadflax vigor and seed production, but may similarly exacerbate the problem by triggering re-growth and spreading seeds. Tilling is effective only if repeated regularly throughout the growing season and for multiple years in a row, but it is generally not feasible in many settings where toadflax infestations occur. Infrequent tilling increases

toadflax infestations because it facilitates the development of new shoots from fragmented roots. Burning is largely ineffective for toadflax control as it typically fails to kill enough of the roots to prevent re-sprouting, and often favors the re-establishment and growth of toadflaxes over less competitive species.

Toadflaxes produce secondary compounds known to deter herbivory, which may make them initially less attractive for grazing; however, with sufficient exposure, acceptance and even preference for grazing on Dalmatian and yellow toadflax typically increase. Livestock and wildlife have been observed browsing toadflaxes, and cattle and sheep have both been “trained” successfully to suppress Dalmatian and yellow toadflax infestations. Grazing toadflaxes can be an effective management strategy under the right circumstances, but it can be difficult and/or time-consuming to implement strategically, and may have negative, long-term consequences for plant communities. Herbicides can provide satisfactory short-term control of small toadflax infestations, but treatments generally need to be repeated regularly for lasting results. Dalmatian toadflax typically requires the use of a surfactant to aid penetration of herbicides into the waxy leaves. Yellow toadflax is thought to be more difficult to control with herbicides than Dalmatian toadflax. For both species, and their hybrids, herbicides can be impractical and uneconomical against very large infestations and may have negative, long-term effects on plant communities.

Due to the difficulties in managing toadflaxes throughout their invaded range, a biological control program was initiated in the 1950s. This manual discusses the biological control of toadflaxes in North America, within the larger context of an integrated toadflax management strategy.

Classical Biological Control of Weeds

Most invasive plants in the United States are not native to North America; they arrived with immigrants, through commerce, or by accident from different parts of the world. These non-native plants are generally introduced without their natural enemies, the complex of organisms that feed on or attack the plant in its native range. A lack of natural enemies is thought to be one reason plant species become invasive pests when introduced to areas outside of their native range.

Biological control of weeds (also called “biocontrol”) of weeds is the deliberate use of living organisms to limit the abundance of a target weed. In this manual, biological control refers to “classical biological control,” which reunites host-specific natural enemies from the weed’s native range with the target weed in its introduced range. Natural enemies used in classical biological control of weeds include different organisms, such as insects, mites, nematodes, and pathogens. In North America, most weed biological control agents are plant-feeding insects, of which beetles, flies, and moths are among the most commonly used.

Biological control agents may attack a weed’s flowers, seeds, roots, foliage, and/or stems. Effective biological control agents seldom kill weeds outright, but work with other stressors such as moisture or nutrient shortages to reduce vigor and reproductive capability, or facilitate secondary infection from pathogens—all of which compromise the weed’s ability to compete with other plant species. Once established, root- and crown-feeding biocontrol agents are

usually more effective against perennial plants that primarily spread by root buds. Flower- and seed-feeding biocontrol agents are typically more useful against annual or biennial plants that spread only by seed. Regardless of the plant part attacked by biocontrol agents, the aim is always to reduce populations of the target weed.

There are advantages and disadvantages to biological control of weeds as a management tool (Table 1).

Table 1. Advantages/disadvantages of classical biological control as a weed management tool.

Advantages	Disadvantages
Target specificity	Will not work on every weed in every setting
Continuous action	Permanent; cannot be undone
Long-term cost-effective; can provide sustained control at the landscape scale	Funding and testing candidate biocontrol agents is expensive; measurable impact may take years or even decades to materialize
Integrates well with other control methods	Approved biocontrol agents are not available for all exotic weeds
Generally environmentally benign	Like all weed control methods, "nontarget" effects are possible, but pre-release testing reduces the risks
Self-dispersing, even into rough or difficult to access terrain	Unpredictable level of control; generally does not eliminate weed

To be approved for release in North America, weed biocontrol agents must be host-specific, meaning they must feed and develop only on the target weed, or in limited cases, on a few closely related plant species. They must never feed on any crop or protected plant species; attack on ornamental plants may be minimally tolerated and is evaluated on a case-by-case basis. Rigorous testing is required to confirm that biocontrol agents are host specific and effective. Potential biocontrol agents often undergo five or more years of testing to ensure that rigid host specificity requirements are met, and results are vetted at a number of stages in the approval process.

The United States Department of Agriculture's Animal and Plant Health Inspection Service - Plant Protection and Quarantine (USDA-APHIS-PPQ) is the federal regulatory agency responsible for providing testing guidelines and authorizing the importation of biocontrol agents into the USA. The Canadian Food Inspection Agency (CFIA) serves the same regulatory role in Canada. Federal laws and regulations are in place to identify and avoid potential risks to native and economically valuable plants and animals that could result from exotic organisms introduced to manage weeds. The Technical Advisory Group (TAG) for Biological Control Agents of Weeds is an expert committee with representatives from USA federal regulatory, resource management, and environmental protection agencies, and regulatory counterparts from Canada and Mexico. TAG members review all petitions to import new biocontrol agents into the USA, and make recommendations to USDA-APHIS-PPQ regarding the safety and potential impact of prospective biocontrol agents. Weed biocontrol researchers work closely with USDA-APHIS-PPQ and TAG to accurately assess the environmental safety of potential weed biocontrol agents and programs. In addition, some states in the USA have their own approval process to permit field release of

weed biocontrol agents. In Canada, the Biological Control Review Committee (BCRC) draws upon the expertise and perspectives of Canadian-based researchers (e.g. entomologists, botanists, ecologists, weed biological control scientists) from academic, government, and private sectors for scientific review of petitions submitted to the CFIA. The BCRC reviews submissions for compliance with the North American Plant Protection Organization's (NAPPO) Regional Standards for Phytosanitary Measures (RSMP) No. 7. The BCRC also reviews submissions to APHIS. The BCRC conclusions factor into the final TAG recommendation to APHIS on whether to support the release of the proposed agent in the USA. When release of an agent is proposed for both the USA and Canada, APHIS and the CFIA attempt to coordinate decisions based on the assessed safety of each country's plant resources.

Code of Best Practices for Classical Biological Control of Weeds

Biological control practitioners have adopted the International Code of Best Practices for Biological Control of Weeds. The Code was developed in 1999 by delegates and participants in the Tenth International Symposium for Biological Control of Weeds to both improve the efficacy of, and reduce potential negative impacts from, weed biological control. In following the Code, practitioners reduce the potential for causing environmental damage through the use of weed biological control by voluntarily restricting biocontrol activities to those most likely to result in success and least likely to cause harm.

International Code of Best Practices for Classical Biological Control of Weeds

1. Ensure that the target weed's potential impact justifies release of non-endemic agents
2. Obtain multi-agency approval for target
3. Select agents with potential to control target
4. Release safe and approved agents
5. Ensure that only the intended agent is released
6. Use appropriate protocols for release and documentation
7. Monitor impact on the target
8. Stop releases of ineffective agents or when control is achieved
9. Monitor impacts on potential nontargets
10. Encourage assessment of changes in plant and animal communities
11. Monitor interaction among agents
12. Communicate results to public

Ratified July 9, 1999, by the delegates to the X International Symposium on Biological Control of Weeds, Bozeman, MT

Although weed biological control is an effective and important weed management tool, it does not work in all cases and should not be expected to eradicate the target weed. Even in the most successful cases, biocontrol often requires multiple years before impacts become noticeable. When classical biological control alone does not result in an acceptable level of weed control, other weed control methods (e.g. physical, cultural, or chemical control) may be incorporated to achieve desired results. For a more in-depth description of all weed control methods in the context of toadflax management, please refer to Chapter 5.

Biological Control of Toadflaxes

Three insect species that likely ‘hitch-hiked’ on yellow toadflax plants imported from Europe are now credited with the earliest incidences of biological control of toadflaxes in North America. The flower-feeding beetle, *Brachyterolus pulicarius*, and two seed-feeding weevils, *Rhinusa antirrhini* (formerly *Gymnetron antirrhini*) and *R. neta* (formerly *Gymnetron netum*), were first recorded between 1909 and 1957 on yellow toadflax growing in the USA and Canada. Following the initiation of the toadflax biocontrol program in the 1950s, five additional species were officially screened for safety, suitability, host specificity, and efficacy.

The first tested and approved toadflax biocontrol agent, the defoliating moth *Calophasia lunula* (Figure 3), was released in Canada in 1962 and subsequently in the USA. During the 1990s, four additional toadflax biological control agents were approved for release in North America, including two root-boring moths (*Eteobalea intermediella* and *E. serratella*), a root-galling weevil (*Rhinusa linariae*, formerly *Gymnetron linariae*), and a stem-mining weevil (*Mecinus janthinus*). Recently, some populations of what was thought to be *Mecinus janthinus* were determined through DNA analysis to be composed of a closely related, but morphologically indistinguishable species, *Mecinus janthiniformis*. Surveys have determined that *M. janthiniformis* preferentially feeds on Dalmatian toadflax and is well established throughout the USA Northwest and southern British Columbia, Canada. A few relatively small-sized populations of *M. janthiniformis* also have been recently found established on Dalmatian toadflax in southern Alberta. *Mecinus janthinus* preferentially feeds on yellow toadflax, and while currently more rarely encountered than *M. janthiniformis*, has recently been confirmed as successfully established at limited sites in the USA and Canada.

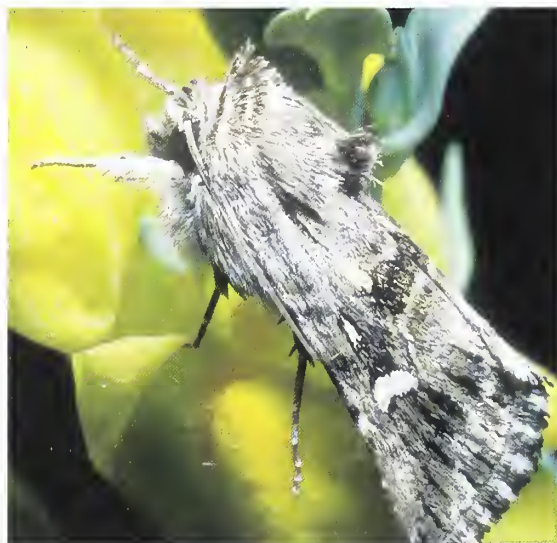

Figure 3. Adult *Calophasia lunula*, the toadflax defoliating moth (Laura Parsons & Mark Schwarzländer, University of Idaho)

Integrated Weed Management

The most effective weed management programs vary weed management activities and control methods based on changing weed populations and management objectives over time (termed Integrated Weed Management or IWM). Weed management activities available to managers include education and prevention, physical (hand pulling, mowing, or tilling), cultural (burning, flooding, grazing, or re-seeding), chemical (herbicides), and biological control. IWM relies on the development of realistic weed management objectives, accurate weed identification and mapping, appropriate control methods, and post-treatment monitoring to ensure current weed-management activities are meeting weed-management goals.

Land managers choose weed control methods that will enable them to achieve their weed management goals or objectives in the most cost-effective manner. No single weed control method will enable managers to meet their toadflax management goals in all environments or instances. Control method(s) employed in IWM will depend on the size and location of the infested area and specific management goals (e.g., eradication vs. weed density reduction). Very small patches of toadflaxes may be eliminated through a persistent hand-pulling or herbicide program, but large infestations will require the use of additional control methods. A combination of control methods consistently applied through time may be necessary to attain and maintain weed management goals for toadflaxes, especially when they infest large areas.

Is Biological Control of Toadflax Right For You?

When biological control is successful, biocontrol agents increase in abundance until they suppress (or contribute to the suppression of) the target weed. As local target weed populations are reduced, their biological control agent populations also decline due to starvation and/or dispersal to other target weed infestations. In many biocontrol systems, there are fluctuations over time with the target weed becoming more abundant, followed by increases of its biocontrol agent, until the target weed/biocontrol agent populations stabilize at a much lower abundance.

While biocontrol has been successful against toadflaxes at many sites in North America, it is not universally effective or appropriate for every toadflax infestation. We recommend that you develop an integrated weed management program in which biological control is one of several weed management approaches considered. Here are some questions you should ask before you begin a biological control program:

Is my management goal to eradicate the weed or reduce its abundance?

Biological control does not eradicate target weeds, so it is not a good fit with an eradication goal. However, depending on the target weed, biological control agent used, and land use, biological control can be effective at reducing the abundance of a target weed to an acceptable level.

How soon do I need results: this season, one to two seasons, or within five to ten years?

Biological control requires time and patience to work. Generally, it can take one to three years after release to confirm that biological control agents are established at a site, and even longer for biocontrol agents to cause significant impacts to the target weed. For some weed infestations, 5-30 years may be needed for biological control to reach its weed management potential.

What resources can I devote to my weed problem?

If you have only a small toadflax problem (few infested acres or much smaller), weed control methods such as hand pulling and/or herbicide applications, followed by regular monitoring for re-growth, may be most effective. These intensive control methods may allow you to achieve rapid control and prevent the weed from infesting more area, especially when infestations occur in high-priority treatment areas such as travel corridors where the weed is more likely to

readily disperse. However, if the target weed is well established over a large area, and resources are limited, biological control may be the most economical weed control option.

Is the weed the problem, or a symptom of the problem?

Invasive plant infestations often occur where desirable plant communities have been or continue to be disturbed. Without restoration of a desirable, resilient plant community, and especially if disturbance continues, biological control is unlikely to solve your weed problems.

The ideal biological control program:

1. is based upon an understanding of the target weed, its habitat, land use and condition, and management objectives
2. is part of a broader integrated weed management program
3. has considered all weed control methods and determined that biological control is the best option based on available resources and weed management objectives
4. has realistic weed management goals and timelines
5. includes resources to ensure adequate monitoring of the target weed, the vegetation community, and populations of biological control agents

About This Manual

This manual provides information on the biology and ecology of Dalmatian toadflax, yellow toadflax, their hybrids, and toadflax biological control agents. It also presents guidelines to establish and manage biological control agents as part of an integrated toadflax management program.

Chapter 1: *Introduction* provides introductory information on toadflaxes (including their distribution, habitat, and economic impact) and classical biological control.

Chapter 2: *Getting to Know Toadflaxes* provides detailed descriptions of the taxonomy, growth characteristics and features, invaded habitats, and occurrence of Dalmatian toadflax, yellow toadflax, and their hybrids in North America. It also describes how to differentiate toadflaxes from look-alike species.

Chapter 3: *Biology of Toadflax Biological Control Agents* describes biological control agents of toadflaxes, including details on each agent's native range, original source of releases in North America, part(s) of toadflax plants attacked, life cycle, description, host specificity, known nontarget effects, habitat preferences, and availability. This chapter is particularly useful for identifying biological control agents in the field.

Chapter 4: *Elements of a Toadflax Biological Control Program* includes detailed information and guidelines on how to plan, implement, monitor, and evaluate an effective toadflax biological control program. Included are guidelines and methods for:

- Selecting and preparing biological control agent release sites
- Collecting, handling, transporting, shipping, and releasing biological control agents
- Monitoring biocontrol agents and vegetation

Chapter 5: *An Integrated Toadflax Management Program* discusses the role of biological control in the context of an integrated toadflax management program.

The Glossary defines technical terms frequently used by those involved in toadflax biological control and found throughout this manual.

References lists selected publications and resources utilized to compile this manual.

Appendices:

- I. Troubleshooting Guide: When Things Go Wrong
- II. Sample Biological Control Agent Release Form
- III. Toadflax Standardized Impact Monitoring Protocol
- IV. General Toadflax Biological Control Agent Monitoring Form
- V. Toadflax Qualitative Monitoring Form
- VI. Toadflax Quantitative Monitoring Form

CHAPTER 2: GETTING TO KNOW TOADFLAXES

Classification

It has been suggested that toadflaxes were so named because toads liked to hide in their foliage, and the shape of toadflax flowers resemble a toad's mouth. The name "toadflax" is applied to several closely related plant species. Formerly members of the figwort family (Scrophulariaceae), they were recently reclassified as members of the plantain family (Plantaginaceae). Closely related plants in this family include the snapdragons; toadflaxes and snapdragons share a unique five-petal flower with distinct upper and lower lips, and a long spur (Figure 4).

Dalmatian toadflax, yellow toadflax, and their hybrids are in the genus *Linaria*. There are approximately 150 species in this genus, none of which are native to North America. Four plant species native to North America were previously considered to be in *Linaria*, but have since been re-classified to a different genus, *Nuttallanthus*. Approximately 13 *Linaria* species and hybrids of two different pairs of *Linaria* occur in the USA and Canada. All species of *Linaria* have smooth-margined leaves that attach directly to the stem without a supporting stalk (petiole). *Linaria* flowers are arranged in long clusters at stem tips and bloom from the bottom upwards.

Of the 13 *Linaria* species present in North America, Dalmatian toadflax [*Linaria dalmatica* (L.) Mill.], yellow toadflax [*Linaria vulgaris* Mill.], and their hybrids are by far the most common and problematic for land managers, and are the focus of this manual. The taxonomy of Dalmatian toadflax is currently in flux and is described in greater detail later in this chapter.

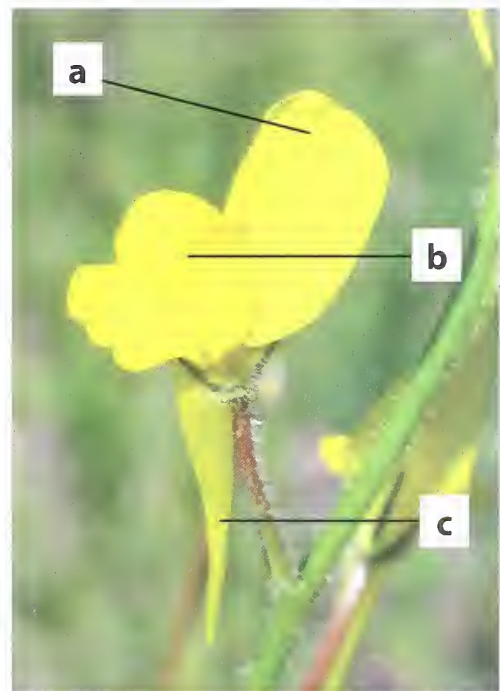

Figure 4. Yellow toadflax (*Linaria vulgaris*) flower. (a) Upper lip, (b) lower lip, (c) spur.

Dalmatian Toadflax

Scientific Name

Linaria dalmatica (L.) Mill

Common Names

Dalmatian toadflax, broad-leaved toadflax, narrow-leaved toadflax

Classification

KINGDOM	Plantae	Plants
SUBKINGDOM	Tracheobionta	Vascular plants
SUPERDIVISION	Spermatophyta	Seed plants
DIVISION	Magnoliophyta	Flowering plants
CLASS	Magnoliopsida	Dicotyledons
SUBCLASS	Asteridae	
ORDER	Lamiales	
FAMILY	Plantaginaceae	Plantain family
GENUS	<i>Linaria</i>	<i>Linaria</i>
SPECIES	<i>Linaria dalmatica</i> (L.) Mill.	Dalmatian toadflax
SUBSPECIES	<i>Linaria dalmatica</i> (L.) Mill. ssp. <i>dalmatica</i> (L.) Mill.	broad-leaved Dalmatian toadflax
	<i>Linaria dalmatica</i> (L.) Mill. ssp. <i>macedonica</i> (Griseb.) D.A. Sutton	narrow-leaved Dalmatian toadflax

History

Dalmatian toadflax was introduced to eastern North America from southeastern Europe by the late 1800s, reportedly as an ornamental plant used by horticulturists in private gardens. Plants that escaped cultivation were collected in California in 1920 and Edmonton, Alberta in 1933.

Description

At a Glance

Dalmatian toadflax (Figures 5, 8) is an erect, herbaceous perennial with one or more stems growing 1-4 feet tall (0.3-1.2 m) from a deep taproot with lateral roots. Leaves are alternate, thick (succulent to leathery), green in color (sometimes blue-green), and often with a waxy surface. Leaves are heart-shaped at the base, clasp the stem, and are typically 1-2 inches long (2.5-5.0 cm) and nearly as wide. Flowers are bright yellow and snapdragon-like with an obvious upper and lower lip and a long spur pointing downward. Each has a fuzzy, yellowish-orange throat. Flowers occur in spiked clusters emerging from leaf axils. Each flower produces a round capsule holding 60-300 small, somewhat triangular seeds.

Roots

Dalmatian toadflax develops taproots that are large, contorted, and deep (up to 4-10 feet or 1.2-3 m in length). Roots have lateral branches that can extend over 10 feet (3 m) from the parent plant, giving rise to vegetative buds that produce new stems. Over time, these shoots form their own roots and eventually become independent plants. Severed root segments as short as 0.4 inches long (1 cm) can develop into new plants.

Stems

Plants typically grow 1-4 feet tall (0.3-1.2 m) and have 1-25 erect stems that are leafy, thick-walled, fibrous and waxy in appearance. Plants also produce non-flowering, prostrate stems (Figure 6a). Prostrate stems typically persist over winter until the following growing season.



Figure 5. Dalmatian toadflax plant (K. George Beck & James Sebastian, Colorado State University)

Leaves

Dalmatian toadflax leaves are long and narrow on seedlings (Figure 6b), but grow significantly wider with age. Mature leaves are heart-shaped at the base, clasp the stem, and are typically 1-2 inches long (2.5-5.0 cm) and nearly as wide. Upper leaves are smaller and oval or lance-shaped. All leaves are alternate, thick, green (sometimes blue-green), often waxy, and have multiple prominent veins.



Figure 6. Dalmatian toadflax a. erect and prostrate stems; b. seedlings; c. mature leaves (a-c Linda Wilson, University of Idaho, bugwood.org)

Flowers

Flowers are bright yellow and snapdragon-like with an obvious upper and lower lip and a long spur pointing downward. Each flower is 0.8-1.6 inches long (2-4 cm) and has a fuzzy, yellowish-orange throat (Figure 7a). Flowers occur in spiked clusters emerging from leaf axils. Flowering occurs throughout the summer.

Fruits and Seeds

Each flower produces a round capsule fruit (Figure 7b) that is 0.2-0.4 inches long (0.5-1.0 cm) and 0.2-0.3 inches wide (0.5-0.75 cm). Each capsule contains 60-300 seeds. Seeds are small, triangular or pyramidal in shape, rough textured, minimally winged, and approximately 0.04 inches long (1 mm) (Figure 7c). A mature plant can produce up to 500,000 seeds annually.

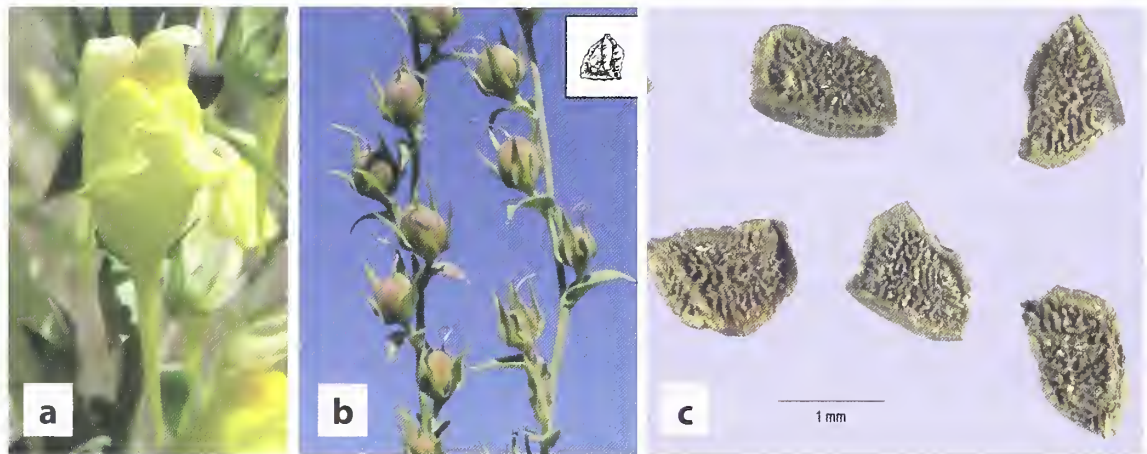

Figure 7. Dalmatian toadflax a. flower (Bonnie Million, National Park Service); b. fruits (Linda Wilson, University of Idaho); c. seeds (Steve Hurst, USDA NRCS PLANTS database) (a-c bugwood.org)

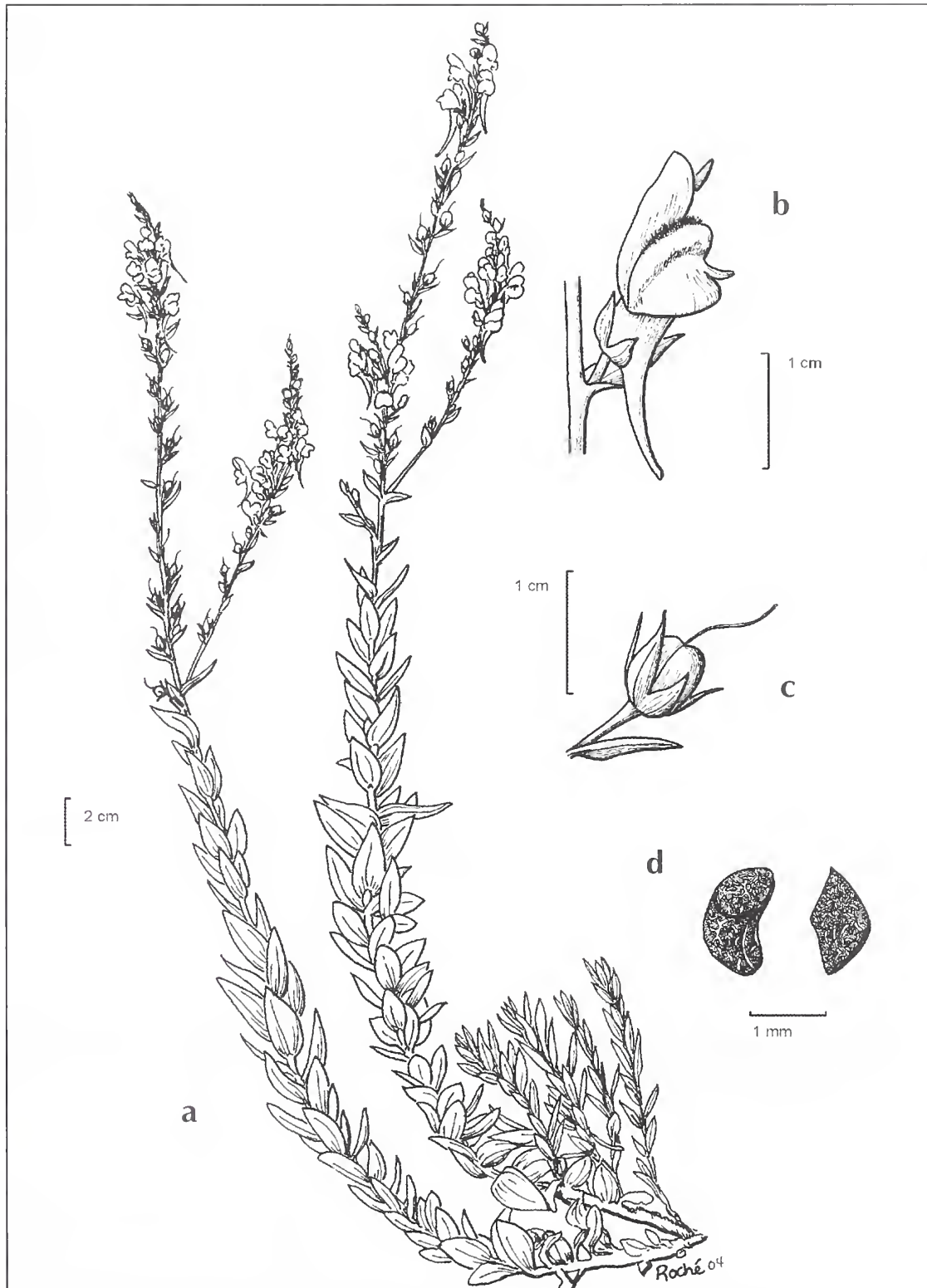

Figure 8. Line drawing of Dalmatian toadflax key traits of a. plant; b. flower; c. fruit; d. seeds

Biology and Ecology

Dalmatian toadflax spreads by seeds and root fragments. Seeds are dispersed fall through winter, and typically spread by humans and animals. Seeds can be caught on motorized equipment, mud on tires or clothing, hay, or animal fur. Because seeds ingested by animals often remain viable upon defecation, livestock, birds, elk, and deer grazing toadflax fruits in autumn is one of the primary modes of toadflax long distance seed dispersal. Many Dalmatian toadflax seeds germinate within one year; however, the soil seed bank can at times yield seedlings ten years after seed drop. The highest rates of germination have been recorded for seeds buried shallowly in loamy or sandy soil.

Some Dalmatian toadflax seeds germinate in fall, but most germinate in spring. Seedlings (Figure 6b) grow quickly, and can establish a 20-inch (51 cm) long taproot within eight weeks of germination. Plants produce 2-5 erect flowering stems and prostrate non-flowering stems the first season (Figure 6a). The prostrate stems sprout in summer or early autumn and remain green throughout the winter, especially under snow cover. In the second year and subsequent years, there can be up to 25 flowering stems and up to 40 non-flowering stems arranged in a loose rosette at the base of the plant. Seasonal growth of stems can begin as early as February in warm areas, or as late as April in cooler, northern or high elevation areas. Flowering occurs throughout summer and fall (May to hard frost, depending on site conditions). Flowers are cross-pollinated by bumblebees and other large bees, and seeds are produced from summer to fall. A mature plant can annually produce up to 500,000 seeds that are gradually released through the fall and winter. Plants re-sprout each spring from adventitious buds on the root crown. Vegetative buds on lateral roots can produce new stems as early as three weeks after germination. Over time, these stems form new roots and eventually become independent plants. Severed root segments as short as 0.4 inches long (1 cm) can also develop into new plants. Dalmatian toadflax plants live 3-5 years on average.

Habitat

Soil disturbance is a very important contributor to Dalmatian toadflax seedling establishment. This weed is often found along railroads, riverbanks, and roadsides (Figure 9a), as well as in fallow fields, slash piles, abandoned lots, and overgrazed rangeland (Figure 9b). A variety of habitat types and plant communities can be invaded or become dominated by Dalmatian toadflax following heavy grazing, trampling, cultivation, logging, and burning. This weed thrives in cool, semiarid conditions and on coarse-textured soils.



Figure 9. Dalmatian toadflax infestations a. along a dirt road (Eric Coombs, Oregon Department of Agriculture); b. in a grazed pasture (Steve Dewey, Utah State University)(a,b bugwood.org)

Distribution

Dalmatian toadflax is considered established in 31 states and ten Canadian provinces (Figure 2b, repeated here in Figure 10a). It has been declared noxious in 14 of the states and three of the provinces in which it is currently established (Figure 10b)

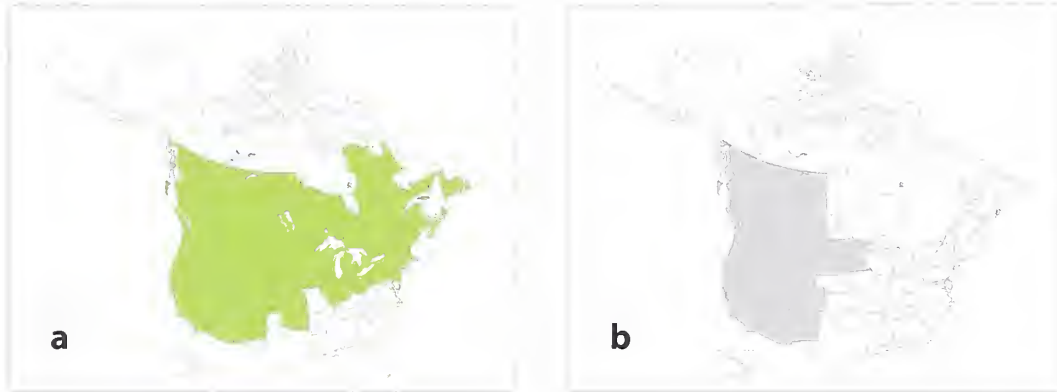

Figure 10. States and provinces where Dalmatian toadflax is a. established (USDA PLANTS Database, EDDMapS); b. listed as noxious.

Taxonomic Issues

The taxonomy and distribution of Dalmatian toadflax have long been a point of contention, primarily due to large variations in leaf appearance. Dalmatian toadflax continues to be referred to by a range of scientific names, including *Linaria genistifolia* (L.) Mill., *Linaria genistifolia* (L.) Mill. ssp. *dalmatica* (L.) Maire & Petitm., and *Linaria dalmatica* (L.) Mill. (alone as well as with two subspecies). Two forms of Dalmatian toadflax are often mentioned (narrow-leaved-



Figure 11. Dalmatian toadflax recovering from drought-stress and grazing exhibiting different leaf forms on the same plant (Sarah M. Ward, Colorado State University)

and broad-leaved). These two forms may correspond to two subspecies (*L. dalmatica* ssp. *macedonica* and *L. dalmatica* ssp. *dalmatica*, respectively), or they may just represent variation in the leaves of one, all-encompassing Dalmatian toadflax species throughout its range. Dalmatian and yellow toadflax hybridizing in North America produce offspring that are intermediate in appearance of the two parental species, often with leaves more narrow than are typical for Dalmatian toadflax, but wider than typical for yellow toadflax. Drought-stressed Dalmatian toadflax plants frequently produce leaves that are narrower than typical, and drought stress later in the growing season can result in both broad and narrow leaves on the same plant (Figure 11).

As of 2015, the taxonomic status of Dalmatian toadflax remains uncertain. The authors of this manual followed the taxonomic interpretation that *Linaria genistifolia* (L.) Mill., known by the common name of broomleaf toadflax, is very closely related to but distinct from *L. dalmatica* (L.)

Mill. *Linaria genistifolia* differs from Dalmatian toadflax primarily in the size of flowers and capsule fruit (Figure 12a-c); *L. genistifolia* flowers are significantly smaller (0.5-0.6 inches long or 12-16 mm) than the flowers of Dalmatian toadflax (0.8-1.6 inches long or 20-40 mm). The presence and distribution of *L. genistifolia* in North America remain unconfirmed at this time. The authors of this manual also followed the interpretation that *L. dalmatica* consists of two subspecies, of which only one (*L. dalmatica* ssp. *dalmatica*) is invasive and weedy in North America. DNA analysis may reveal that plants designated as one of the two subspecies of Dalmatian toadflax, or categorized as narrow- or broad-leaved forms of *L. dalmatica*, may in fact be hybrids of Dalmatian and yellow toadflax. The two forms may be unique species, whereby broad-leaved refers to *L. dalmatica* ssp. *dalmatica* and narrow-leaved refers to *L. genistifolia*. These uncertainties are currently being addressed.

All of the control information presented in this manual for “Dalmatian toadflax” applies to wide-leaved toadflax prevalent throughout North America, regardless of what species, subspecies, or form the ongoing genetic studies may reveal individual plants to be. When information is known to apply to confirmed Dalmatian and yellow toadflax hybrids, that information will be presented separately.

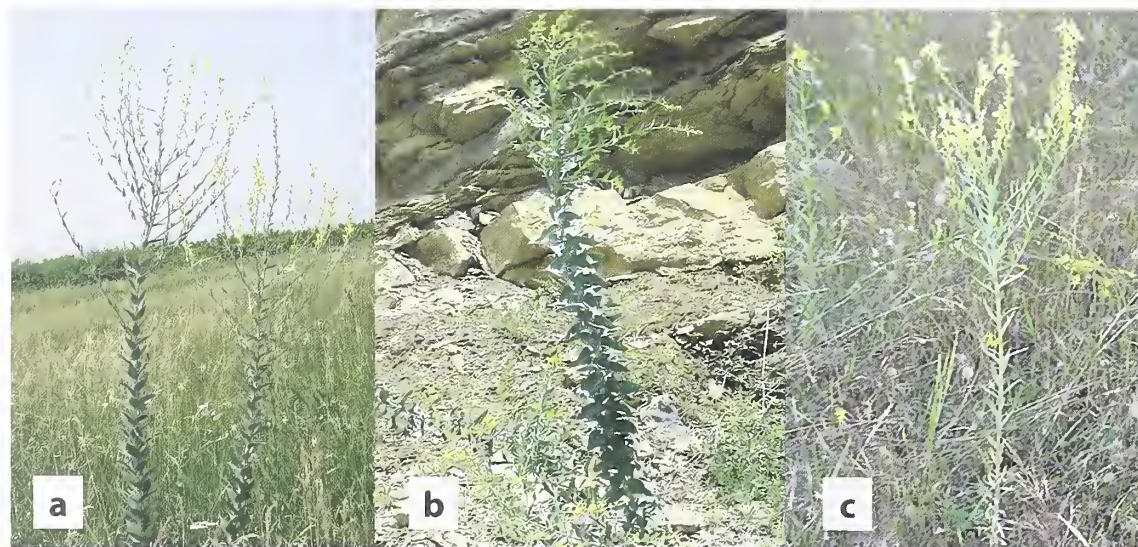

Figure 12. Broomleaf toadflax, *Linaria genistifolia*, growing in Europe a,b. wide-leaved form; c. narrow-leaved form (a-c Ivo Toševski, CABI)

Comments

Toadflaxes produce secondary compounds known to deter herbivory, which may make them initially less attractive for grazing; however, with sufficient exposure, acceptance and even preference for grazing on Dalmatian toadflax typically increase. Cattle, sheep, and goats have been used to graze on and suppress Dalmatian toadflax. Grazing animals will pass viable Dalmatian toadflax seed in their excrement, so it is important to corral animals that have grazed on mature toadflax plants and feed them weed-seed free forage/hay to ensure the Dalmatian toadflax seed has been eliminated before moving them onto other pastures. This may take up to 72 hours.

Commonly Confused Species

The combination of yellow, snapdragon-like flowers and large, waxy, heart-shaped or triangular leaves help differentiate Dalmatian toadflax from most potential look-alike species in North America. Myrtle spurge (*Euphorbia myrsinites* L.) is similar in appearance to Dalmatian toadflax (Figure 13a), except that myrtle spurge stems lean over instead of growing upright, they produce a milky sap when wounded, and they have typical spurge-type flowers that are green, inconspicuous, and surrounded by yellow-green bracts. Myrtle spurge is also listed as a noxious weed in several states. Goldenbanner species, including *Thermopsis montana* Nutt. and *Thermopsis rhombifolia* (Pursh) Richardson, have large, showy yellow flowers similar to Dalmatian toadflax, especially when viewed from afar (Figure 13b). Closer inspection reveals that goldenbanner leaves are always 3-parted and not succulent, and goldenbanner flowers do not have long spurs. The leaves, stems, and growth form of bastard toadflax (*Comandra umbellata* (L.) Nutt.) resemble those of Dalmatian toadflax; however, bastard toadflax leaves do not feel waxy to the touch, as they do for Dalmatian toadflax. Bastard toadflax also differs in its shorter overall height (maximum 1 foot or 30 cm), roots that are parasitic on other plants and also turn robin's-egg blue when cut, and tiny whitish-pink flowers that appear only on the tip of the main stem (see Table 2 on page 26).

Most other *Linaria* species present in North America (all of them exotic) have pink, purple, or bi-colored flowers. *Linaria* species present in North America that have yellow flowers are more likely to be confused with yellow toadflax and so are discussed on page 26. Yellow toadflax and yellow/Dalmatian toadflax hybrids are the plants most likely to be confused with Dalmatian toadflax. A section devoted to differentiating yellow, Dalmatian toadflax, and their hybrids can be found on page 34.

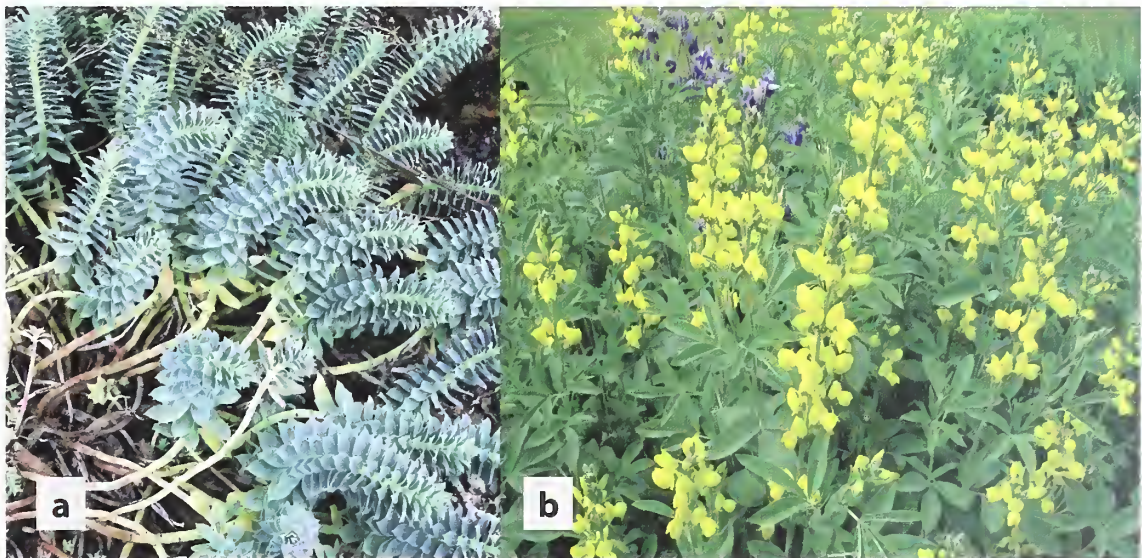

Figure 13. Potential Dalmatian toadflax look-alikes a. myrtle spurge (*Euphorbia myrsinites*) (Jebulon); b. mountain goldenbanner (*Thermopsis montana*)(Steve Law)

Yellow Toadflax

Scientific Name

Linaria vulgaris Mill.

Common Names

Yellow toadflax, common toadflax, butter-and-eggs, toad-flax, wild snapdragon, perennial snapdragon, flaxweed, ramsted, eggs and bacon, Jacob's-ladder, common linaria, rabbit-flower, impudent lawyer

Classification

KINGDOM	Plantae	Plants
SUBKINGDOM	Tracheobionta	Vascular plants
SUPERDIVISION	Spermatophyta	Seed plants
DIVISION	Magnoliophyta	Flowering plants
CLASS	Magnoliopsida	Dicotyledons
SUBCLASS	Asteridae	
ORDER	Lamiales	
FAMILY	Plantaginaceae	Plantain family
GENUS	<i>Linaria</i>	Linaria
SPECIES	<i>Linaria vulgaris</i> Mill.	Yellow toadflax

History

Yellow toadflax was introduced to North America from Eurasia by the late 1600s, likely as an ornamental plant, and for use in fabric dye and folk remedies. Yellow toadflax reportedly become naturalized in some eastern American colonies by 1671 and was considered a significant and fairly common agricultural weed as early as 1849. In Canada, yellow toadflax was first collected in the early 1800s in southern Quebec. The weed spread throughout the Prairie provinces, forming large populations in the early to mid-1900s.

Description

At a Glance

Yellow toadflax (Figures 14, 18) is an erect, herbaceous perennial typically growing numerous stems 1-3 feet tall (0.3-1.0 m) from a taproot with spreading lateral roots. Leaves are alternate, green, pointed at both ends, and may have small petiole-like stalks. Older leaves are narrow and typically 1-2 inches long (2.5-5.0 cm) with a large central vein on the underside. Flowers are pale yellow and snapdragon-like with an obvious upper and lower lip and a spur pointing downward. Each has a fuzzy, bright orange throat. Flowers occur in spiked clusters at the top of the stem. Each flower produces an oval capsule fruit holding 10-40 viable, flat, disc-shaped seeds.

Roots

Yellow toadflax develops taproots that can grow up to 3.3 feet deep (1 m). Roots have lateral branches that can extend several yards (meters) from the parent plant. Lateral roots have vegetative buds that produce new stems. Severed root segments as short as 4 inches long (10 cm) can develop into new plants.

Stems

Plants typically grow 1-3 feet tall (0.3-1.0 m), though stem height can vary dramatically, even for plants growing in the same vicinity (Figure 15a,b). Plants produce a few to hundreds of erect, leafy stems (Figure 14a). Most stems are woody and somewhat reddish at their base, becoming more slender, succulent, and greener toward the growing tip. Yellow toadflax stems die back completely in winter; unlike Dalmatian toadflax, yellow toadflax does not produce an overwintering rosette.



Figure 14. Yellow toadflax plant (Linda Wilson, Ivo Toševski, CABI)

Leaves

Yellow toadflax leaves are alternate, pointed at both ends, and may be attached to the stem by small petiole-like stalks, though these are sometimes absent. Older leaves are narrow and typically 1-2 inches long (2.5-5.0 cm) with an obvious central vein on the underside. Leaves are green, often with a silvery tinge (Figure 16b). Though all yellow toadflax leaves are linear and have a consistent width along their length, the overall leaf width can vary significantly between infestations. Some leaves are quite slender and feathery (Figure 16a), some are moderately more robust but still pointed at the tip (Figure 16b), while others can be somewhat wider with rounded tips that give them the shape of a baseball bat (Figure 16c). Experienced observers may find that yellow toadflax leaves give off a distinctive “cat urine” odor.

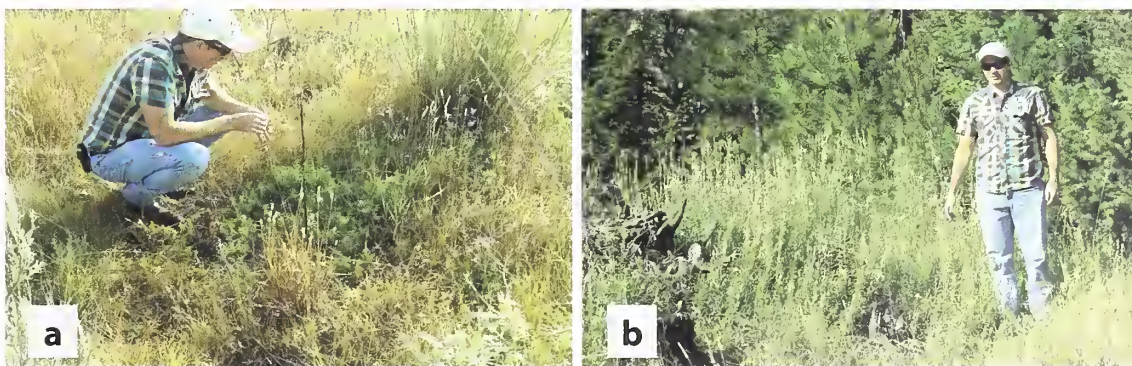

Figure 15. Yellow toadflax populations with a. short individuals; b. tall individuals (a, b Sharlene E. Sing, USDA FS RMRS)



Figure 16. Yellow toadflax a. stems with feathery leaves; b. mid-width leaves (a, b Michael Shephard, Forest Service, bugwood.org); c. robust, rounded leaves (Sharlene E. Sing, USDA FS RMRS)

Flowers

Flowers are pale yellow and snapdragon-like with an obvious upper and lower lip and a spur pointing downward. The spur on yellow toadflax flowers is reduced compared to that on Dalmatian toadflax. Each flower is 0.8-1.6 inches long (2-4 cm) with a fuzzy, bright orange throat that functions as a nectar guide to entice pollinators (Figure 17a). Flowers occur in tightly grouped, spiked clusters at the tops of stems in groups of 6-30. Flowering occurs throughout the summer and into fall at some locations.

Fruits and Seeds

Each flower produces an oval-shaped capsule fruit (Figure 17b) that is 0.2-0.5 inches long (0.5-1.2 cm). Seed capsules have the potential to produce a maximum of 250 seeds, though most contain only 10-40 viable seeds. Seeds are very small, lightweight, flat, prominently winged discs, and approximately 0.06 inches in diameter (1.5 mm) (Figure 17c). A mature plant produces 1,500 to 30,000 seeds annually.



Figure 17. Yellow toadflax a. flowers (Michael Shephard, Forest Service); b. fruits (John Cardina, Ohio State University); c. seeds (Steve Hurst, USDA NRCS PLANTS database) (a-c bugwood.org)

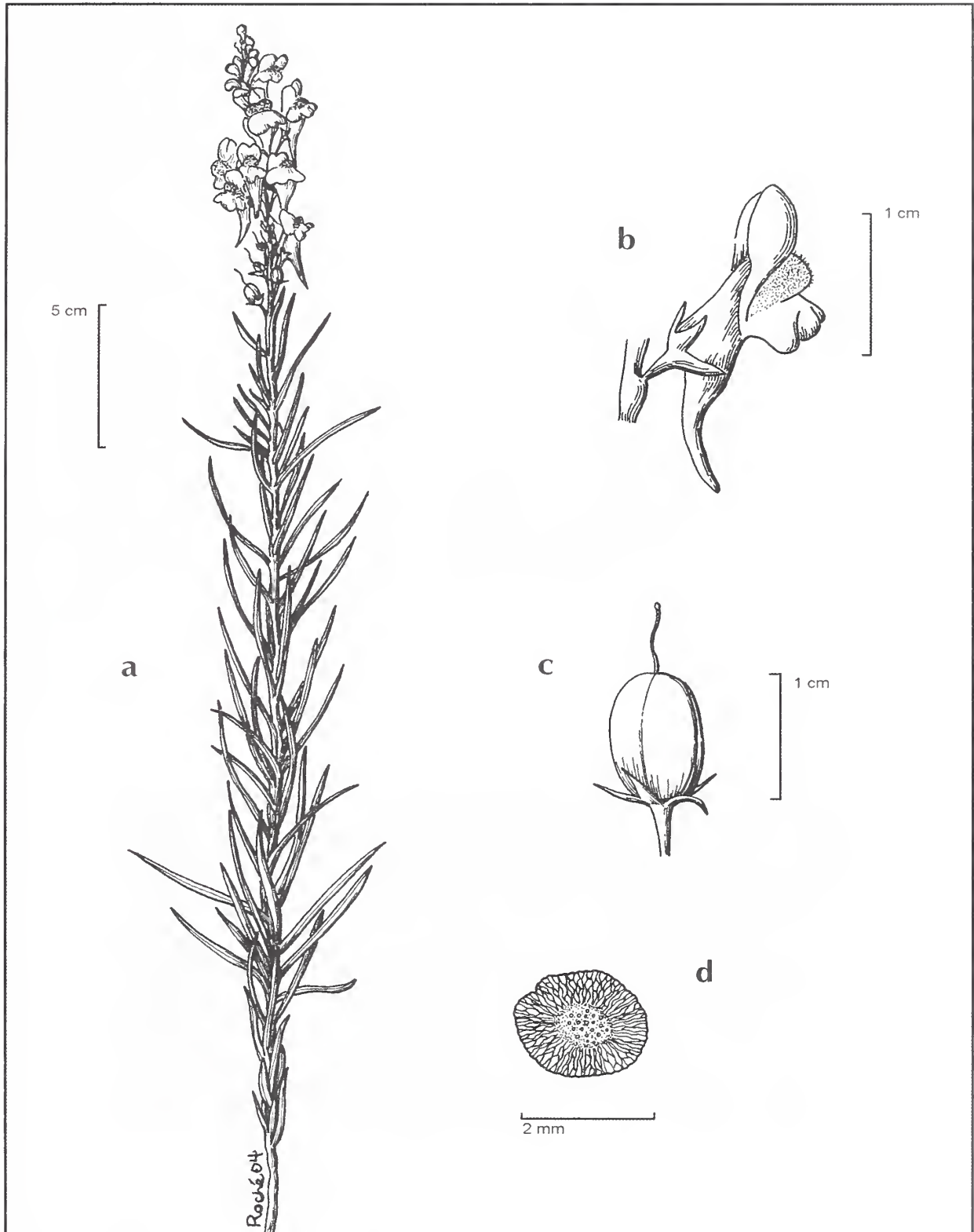

Figure 18. Line drawing of yellow toadflax key traits of a. plant; b. flower; c. fruit; d. seed

Biology and Ecology

Yellow toadflax spreads by seeds, creeping roots, and root fragments. Seeds are dispersed from late summer through winter, and typically spread by humans and animals. Seeds can be caught on motorized equipment, mud on tires or clothing, hay, or animal fur. Because seeds ingested by animals often remain viable upon defecation, livestock, birds, elk, and deer grazing toadflax fruits in autumn is one of the primary modes of toadflax long distance seed dispersal. Yellow toadflax seeds have low viability, with germination rates commonly less than 50%. Some researchers have reported that seed capsules maturing late in the season (November) contained more viable seeds than those maturing earlier in the season (September), though this may not be true for all yellow toadflax populations. While some yellow toadflax seeds germinate immediately, many can remain dormant but viable in the soil for 8 years or more.

Yellow toadflax seeds germinate in spring. Seedlings grow quickly, developing lateral roots capable of vegetative reproduction within three weeks of germination. Plants can produce up to 100 stems from the root system during the first growing season, then up to 250 new shoots during the second year. Because all yellow toadflax stems die back completely in winter, spring re-growth in established plants occurs only from sub-soil root buds (Figure 19a) and not, as is the case for Dalmatian toadflax, from an overwintered rosette. Spring stem growth (Figure 19b) begins as early as March in warm regions, or in April or even later in cooler, more northerly or high elevation sites. Flowering occurs throughout summer and into fall (May to November, depending on site conditions). Flowers are cross-pollinated by bumblebees and other large bees, and seeds are produced from summer to fall. A mature plant can produce 1,500 to 30,000 seeds annually, on average. These are gradually released from the seed capsules throughout fall and winter. Plants re-sprout each spring from adventitious buds in their roots. Severed root segments as short as 4 inches long (10 cm) can also develop into new plants. Yellow toadflax plants live four years on average.



Figure 19. Yellow toadflax a. overwintering subsoil root buds (inside yellow circle); b. stems sprouting in spring (a, b Sharlene E. Sing, USDA FS RMRS)

Habitat

Soil disturbance can be an important contributor to yellow toadflax seedling establishment. The weed is often found at chronically disturbed sites such as roadsides, railroads, cultivated fields, pastures, and rangeland. Yellow toadflax has also been found in backcountry locations where there has been very little to no disturbance, indicating it also has the ability to invade healthy ecosystems. Yellow toadflax is a common weed across North America occurring in a variety of habitat types and plant communities (Figure 18a-c). It is frequently found in more fertile and moist soil than Dalmatian toadflax.



Figure 20. Yellow toadflax infestations a. plants in a roll of barbed wire; b. in a montane forest opening (a, b Hal Pearce, USDA FS); c. in a field in the sagebrush steppe (Mark Schwarzländer, University of Idaho, bugwood.org)

Distribution

As of 2015, yellow toadflax is considered established in all 49 continental states, ten Canadian provinces and two Canadian territories (Figure 2a, repeated here in Figure 21a). It has been declared noxious in 13 of the states and three of the provinces where it is currently established (Figure 21b). Yellow toadflax is more likely to be a minor contributor to plant communities composed of mixed weedy and native species in the eastern USA and Canada, but is capable of generating significant monoculture infestations in the Intermountain West.

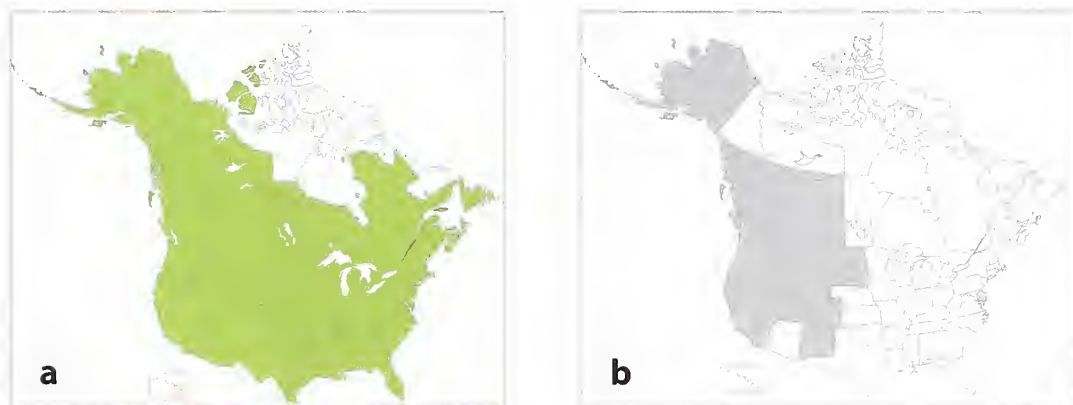

Figure 21. States and provinces where yellow toadflax is a. established (USDA PLANTS Database, EDDMapS); b. listed as noxious

Comments

Toadflaxes produce secondary compounds known to deter herbivory, which may make them initially less attractive for grazing; however, with sufficient exposure, acceptance and even preference for grazing on yellow toadflax typically increase. Both cattle and sheep have been trained to feed on yellow toadflax. Grazing animals can pass viable yellow toadflax seed in their excrement, so it is important to corral animals that have grazed on mature toadflax plants, and feed them weed-seed free forage/hay to ensure the yellow toadflax seed has been eliminated before moving them onto other pastures. This may take up to 72 hours.

In states where yellow toadflax is not listed as noxious, it still is sold by some nurseries as “butter and eggs,” “Jacob’s ladder,” or “wild snapdragons,” and is frequently included in seed mixes sold for wildflower and pollinator gardens.





Commonly Confused Species

The large, yellow snapdragon-like flowers help differentiate yellow toadflax from most potential look-alikes. The majority of *Linaria* species present in North America (all of them exotic) have pink, purple, or bi-colored flowers. There are two *Linaria* species present in North America and one cultivated yellow snapdragon (*Antirrhinum majus* L.) with similar yellow flowers that could be confused with yellow toadflax. Other species present in North America have foliage and growth traits similar to yellow toadflax, and could be confused for this species, especially when observed prior to flowering. Some of the species that most closely resemble yellow toadflax are listed in Table 2, along with key characteristics that can be used to differentiate the look-alikes.

Dalmatian toadflax and yellow/Dalmatian toadflax hybrids are the plants most likely to be confused with yellow toadflax. A section devoted to differentiating yellow, Dalmatian toadflax, and their hybrids can be found in Table 3 on page 34.

Table 2. North American species similar in appearance to yellow toadflax, and key traits for differentiation.

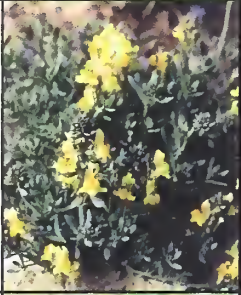
SPECIES	IMAGE	DIFFERENTIATING FEATURES
Ballast toadflax <i>Linaria spartea</i> Plantain Family Exotic annual forb Weed		Ballast toadflax, an exotic <i>Linaria</i> reportedly present only in Connecticut and Michigan, is weedy along roadsides, fields and waste areas. Similarities to yellow toadflax: snapdragon-like flowers; narrow leaves. Differences from yellow toadflax: lacks lateral roots; tiny but obvious hairs present on upper stems; leaves are narrower (less than 1 mm wide).

SPECIES	IMAGE	DIFFERENTIATING FEATURES
<p>Bastard toadflax <i>Comandra umbellata</i> Sandalwood Family Native perennial forb or subshrub</p>		<p>Bastard toadflax grows on open wooded hillsides, rocky outcrops, and in upland rangeland. Similarities to yellow toadflax: habitats occupied; leaf and growth form; stems have a reddish-colored base. Differences from yellow toadflax: shorter height (maximum 1 foot or 30 cm); presence of rhizomes; parasitic roots; rhizomes turn robin's-egg blue when cut; leaves drier to the touch with obvious lateral veins on the underside; tiny, whitish-pink, five-petal flowers that only appear at the tip of the stem.</p>
<p>Leafy spurge <i>Euphorbia esula</i> Spurge Family Exotic perennial forb Weedy; listed as noxious in many states</p>		<p>Leafy spurge, also frequently listed as a noxious weed, inhabits many of the same habitats as yellow toadflax. Similarities to yellow toadflax: creeping lateral roots; linear leaves; growth form. Differences from yellow toadflax: milky sap produced by foliage and stem when damaged; inconspicuous green flowers surrounded by yellow-green bracts.</p>
<p>Leafy spurge <i>Euphorbia esula</i> Spurge Family Exotic perennial forb Weedy; listed as noxious in many states</p>		<p>Prostrate toadflax is a rare, exotic <i>Linaria</i> ornamental that could escape into disturbed, waste areas, similar to yellow toadflax. Other similarities to yellow toadflax: yellow snapdragon-like flowers; long, narrow leaves. Differences from yellow toadflax: does not have lateral roots; upper stems have tiny hairs; leaves are narrower; stems are more sprawling; maximum plant height is 8 inches (20 cm).</p>
<p>Stoneseed <i>Lithospermum ruderale</i> Forget-me-not Family Native perennial forb</p>		<p>Stoneseed grows in similar habitats to yellow toadflax in western North America, including rangeland, forest openings, moist roadsides, and abandoned fields. Similarities to yellow toadflax: height; produces numerous stems; leaf shape and form of leaf attachment to stem. Differences from yellow toadflax: does not have lateral roots; leaves and stems are covered with fine hairs; has small, star-shaped flowers with 5 whitish-yellow petals.</p>
<p>Yellow snapdragon <i>Antirrhinum majus</i> Plantain Family Exotic annual to perennial forb Used as an ornamental</p>		<p>Yellow snapdragon is often planted as an ornamental; it could co-occur with yellow toadflax where it has escaped cultivation or where yellow toadflax invades gardens and fields. Similarities to yellow toadflax: color and form of flowers; alternate, long, and narrow leaves. Differences from yellow toadflax: flowers and leaves are larger; has multiple leaves per axil; roots are typically fine and not creeping.</p>

Ballast toadflax (Javier Martin); Bastard toadflax (© 2015 Keir Morse); Leafy spurge (K. George Beck & James Sebastian, Colorado State University, bugwood.org); Prostrate toadflax (Ghislain 118 (AD)); Stoneseed (Matt Lavin, Bozeman MT); Yellow snapdragon (MChance666)

Hybrid Toadflax

Scientific Name

Linaria vulgaris x *L. dalmatica*; *Linaria dalmatica* x *L. vulgaris*

Common Names

Hybrid toadflax

Classification

KINGDOM	Plantae	Plants
SUBKINGDOM	Tracheobionta	Vascular plants
SUPERDIVISION	Spermatophyta	Seed plants
DIVISION	Magnoliophyta	Flowering plants
CLASS	Magnoliopsida	Dicotyledons
SUBCLASS	Asteridae	
ORDER	Lamiales	
FAMILY	Plantaginaceae	Plantain family
GENUS	<i>Linaria</i>	<i>Linaria</i>
SPECIES	<i>Linaria vulgaris</i> x <i>L. dalmatica</i>	Hybrid toadflax

History

By the late 1800s, yellow and Dalmatian toadflax were introduced to North America from Eurasia and southeastern Europe, respectively, for ornamental and medicinal purposes. Hybrids of these species were first reported in North America in 2009.

Description

Due to the many possible combinations of genetic contributions of either parental toadflax species, a set description for hybrid toadflax is impossible. Hybrids may very closely resemble Dalmatian toadflax if the genetic contribution from yellow toadflax was only minor, or vice versa. In the most clear-cut cases, hybrid toadflax presents traits that are truly intermediate between both parent species (Figure 22). The below descriptions are based on a combination of traits exhibited by both parental toadflax species and are supplemented by field observations.

Hybrid toadflaxes are erect, herbaceous perennials that grow few to numerous stems 1-3 feet tall (0.3-1.2 m), although individual hybrids may grow shorter or taller depending on site conditions and the interaction of genes. Dalmatian toadflax has a prominent taproot with short lateral roots, while yellow toadflax has a comparatively smaller taproot and more developed lateral roots. Hybrids observed in the field have possessed prominent taproots as well as prominent lateral roots.



Figure 22. Toadflax plants a. Dalmatian toadflax; b,c. hybrid toadflax; d. yellow toadflax (a-d Sharlene E. Sing, USDA FS RMRS)

Dalmatian toadflax leaves are often heart-shaped, waxy, thick, clasp the stem, and have multiple veins (Figure 22a) while yellow toadflax leaves are often long and narrow, non-waxy and thin, and have short stalks and a single prominent midvein (Figure 22d). The leaves on hybrid toadflax are highly variable in terms of size, shape, and color (Figure 22b,c; Figure 23a-c). Hybrid leaves are generally wider than yellow toadflax leaves, usually do not clasp the stem, have a prominent midvein as well as multiple, less prominent side veins, and are intermediate in terms of thickness and waxy texture. Because both Dalmatian and yellow toadflax leaves can vary considerably depending on local population genetics and site conditions (Figure 22a,d), intermediate leaf forms are not always a reliable characteristic for identifying hybrid individuals.



Figure 23. Variation in hybrid toadflax leaves (a-c Sarah M. Ward, Colorado State University)

Hybrid toadflax blossoms can range in color from the pale yellow of yellow toadflax to the bright yellow of Dalmatian toadflax (Figure 24 a-c). Hybrids have an orange throat, though this can sometimes resemble either the vibrant orange throat of yellow toadflax or the less bright coloration of Dalmatian toadflax. Similar to both parent species, hybrid toadflax flowers have a snapdragon-like shape with two lips and a long spur. Hybrid toadflax flowers occur in spiked clusters either at the top of the stem or from leaf axils from summer through fall. Fruit capsules of hybrid toadflax are similar in size and shape to both Dalmatian and yellow toadflax (round and 0.2-0.5 inches or 0.5-1.2 cm long). Hybrid seeds are variable in shape; they can resemble those of Dalmatian or yellow toadflax, or be intermediate in form (Figure 25).



Figure 24. Variation in hybrid toadflax flowers (a-d Sarah M. Ward, Colorado State University; e Sharlene E. Sing, USDA FS RMRS)

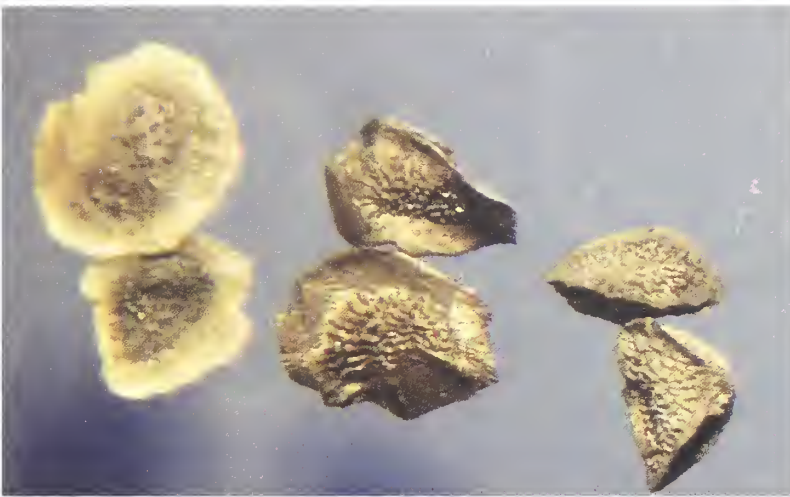

Figure 25. Toadflax seeds: yellow toadflax (left), hybrid toadflax (center), Dalmatian toadflax (right) (Sarah M. Ward, Colorado State University)

Biology and Ecology

Similar to both parent species, hybrid toadflax spreads by seeds, lateral roots, and root fragments. Toadflax hybrid seeds are highly viable, dispersed from late summer through winter, and are likely spread by humans and animals. Seeds can likely be caught on motorized equipment, mud on tires or clothing, hay, or animal fur. As far as we know, hybrid toadflax seeds ingested by animals may remain viable upon defecation, and so ingestion by livestock, birds, elk, and deer grazing toadflax fruits in autumn may contribute to long distance seed dispersal. Hybrid toadflax grown under controlled conditions produces large quantities of viable seeds. Seed production by hybrids growing under typical field conditions and across the full range of known hybrid-infested sites requires additional investigation.

Seasonal growth of stems has been observed as beginning earlier in the spring for hybrid toadflax compared to either parent species. Flowering occurs throughout summer and into fall, depending on site conditions. Similar to both parent species, hybrid flowers are cross-

pollinated by bumblebees and other large bees, and seeds are produced from summer to fall. It is not yet known how long hybrid toadflax plants live on average, though neither parent species typically lives longer than five years.

Habitat

Soil disturbance is a very important contributor to Dalmatian and yellow toadflax seedling establishment. Hybrid toadflaxes have been found in chronically disturbed sites suitable for either parent species, including roadsides, riverbanks, slash piles, abandoned lots, pastures, and rangeland in a variety of soils and climatic conditions (Figure 26a-b). The presence of both Dalmatian and yellow toadflax on-site increases the possibility that hybridization has taken place, although on some sites, either or both parental species may have been eliminated by competitively superior hybrid offspring.



Figure 26. Hybrid toadflax infestations a. in a forest understory, with Dalmatian toadflax uphill, hybrid toadflax plants mid-slope, and yellow toadflax downhill; b. following a prescribed burn for aspen regeneration (a,b Sharlene E. Sing, USDA FS RMRS)

Distribution

As of 2015, hybrid toadflaxes were confirmed as present in five western states (Figure 2c, repeated here in Figure 27a). Scouting continues to be the best way to identify other potential hybrid toadflax populations in North America. Due to the recent confirmation of naturally occurring infestations, hybrid toadflax has thus far only been listed as noxious in Colorado. However, the other states and provinces where the parent species are declared noxious (Figures 10b and 17b, repeated here in Figures 27b and 27c, respectively) may likely also treat hybrid toadflax as noxious.

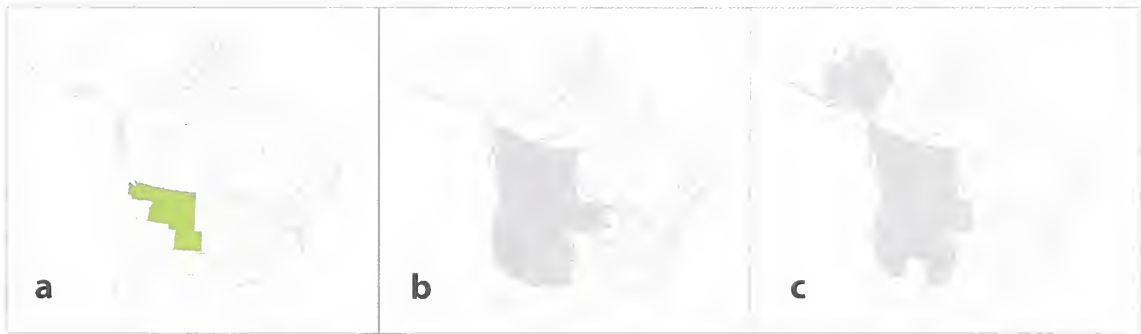



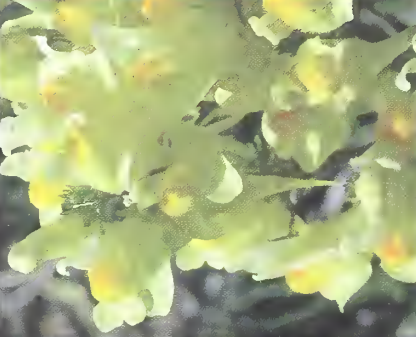

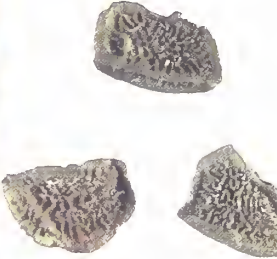
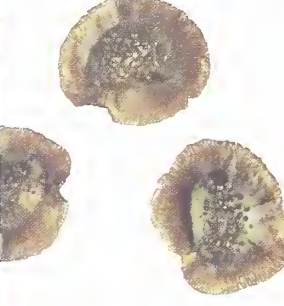
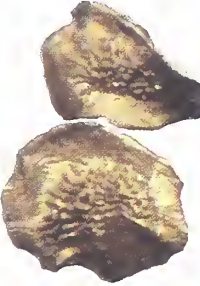

Figure 27. States and provinces where a. hybrid toadflax is established (Sarah M. Ward, unpublished data); b. Dalmatian toadflax is listed as noxious; c. yellow toadflax is listed as noxious

Comments

Grazing animals can pass viable yellow and Dalmatian toadflax seed in their excrement. Though not yet studied, this is likely also true for hybrid toadflax. It is important to corral animals that have grazed on mature toadflax plants, and feed them weed-seed free forage/hay to ensure the toadflax seed has been eliminated before moving them onto other pastures. This may take up to 72 hours.

Table 3. Comparison of Dalmatian toadflax, yellow toadflax, and their hybrids.

Feature	Dalmatian toadflax	Yellow toadflax	Hybrid toadflax
<p>LEAVES Dalmatian: waxy, heart-shaped, significant outward bulging mid-leaf, clasping, multiple prominent veins Yellow: not waxy, linear (consistent width entire length), short stalk (non-clasping), single prominent vein, 'aromatic' Hybrid: often one prominent midvein with many less prominent side veins, many intermediate combinations of both parents, mid-leaf outward bulging typically less exaggerated than in Dalmatian toadflax</p>			
<p>FLOWERS Dalmatian: bright yellow, yellowish-orange throat, long spur Yellow: pale yellow, bright orange throat, spur and blossom slightly shorter than Dalmatian toadflax, tight clustering of flowers resembles small popcorn balls Hybrid: often medium orange throat, many intermediate combinations of both parents</p>			
<p>SEEDS Dalmatian: triangular Yellow: winged, rounded Hybrid: moderately winged triangular</p>			

Dalmatian, yellow, and hybrid toadflax leaves (Sharlene E. Sing, USDA FS RMRS); Dalmatian toadflax flowers (Bonnie Million, National Park Service, bugwood.org), yellow toadflax flowers (Mary Ellen Harte, bugwood.org); Dalmatian and yellow toadflax seeds (Steve Hurst, USDA NRCS PLANTS database); Hybrid toadflax flowers, seeds (Sarah M. Ward, Colorado State University)

CHAPTER 3: BIOLOGY OF TOADFLAX BIOCONTROL AGENTS

Basic Insect Biology

Insects are the largest and most diverse class of animals. Basic knowledge of insect anatomy and lifecycle will help in understanding insects, and recognizing them in the field.

Most insects used in weed biocontrol have complete metamorphosis, which means they exhibit a life cycle with four distinct stages: egg, larva, pupa, and adult (Figure 28). Insects have an exoskeleton (a hard external skeleton) and a segmented body divided into three regions (head, thorax, and abdomen, Figure 29a,b). Adult insects have three pairs of segmented legs attached to the thorax, and a head with one pair each of compound eyes and antennae.

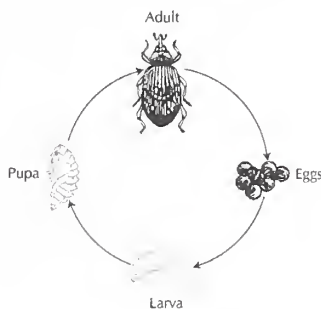

Figure 28. Line drawings of a beetle lifecycle showing complete metamorphosis (University of Idaho)

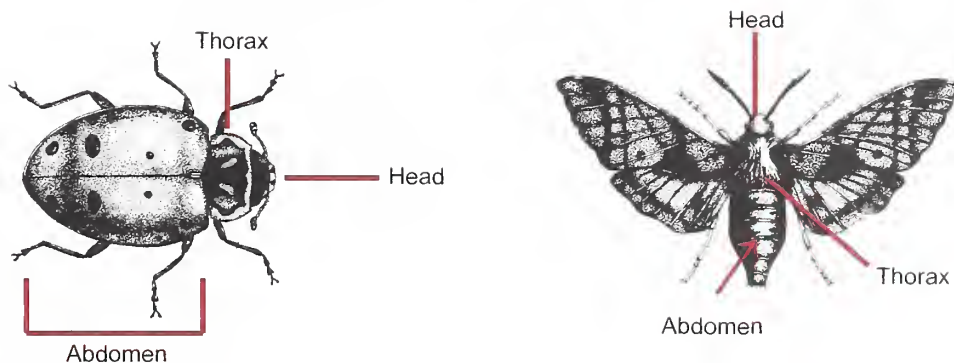

Figure 29. Line drawings of insect anatomy a. beetle; b. moth (a,b adapted from *Biological Control of Weeds in the West*, Rees et al. 1996)

Because insects have an external skeleton, they must shed their skeleton in order to grow. This process of shedding the exoskeleton is called molting. Larval stages between molts are called “instars.” Larvae generally complete three to five instars before they molt into pupae. During the pupal stage, insects change from larvae to adults. Insects do not feed or molt during the pupal stage. Adult insects emerge from the pupal stage and do not grow or molt.

Toadflax Biological Control Agents

Nine species of exotic insects have been intentionally or accidentally introduced for biocontrol of toadflax in North America. They belong to two groups: beetles and moths.

Beetles (Order Coleoptera)

Adult beetles are hard-bodied insects with tough exoskeletons. Adult beetles possess two pairs of wings. The two front wings, called elytra, are thickened and meet in a straight line down the abdomen, forming a hard, shell-like, protective covering (Figure 29a). The two hind wings are membranous and used for flight. These are larger and are folded under the elytra when not in use. Beetle larvae are grub- or worm-like with three small pairs of legs, allowing some to be quite mobile. Many are pale white with a brown or black head capsule, though some may be quite colorful and change markedly in appearance as they grow. Beetles, like those used for toadflax biocontrol, have chewing mouthparts.

Species from two different families are used for toadflax biocontrol: weevils (Curculionidae) and flower beetles (Kateretidae). Weevils are plant-feeding beetles with chewing mouthparts at the tip of a long snout. They use their snouts to chew inside plant tissues to feed or to notch out holes in which they lay their eggs. Some adult weevils cause significant foliar feeding damage. Weevil larvae feed internally in the flowers, seeds, stems, or roots of their target plants. Weevil larvae often cause more damage to plants than adult weevils.

Adult flower beetles are small, dark, oval insects that eat leaves, young stems, and occasionally floral tissues and pollen. Flower beetle larvae live inside the flower and consume floral tissue, pollen, and developing seeds. Both larval and adult flower beetles can cause significant feeding damage to their host plants.

Butterflies and Moths (Order Lepidoptera)

Adult moths are soft-bodied insects with two pair of membranous wings that are covered with powder-like scales (Figure 29b). Adult moths have prominent antennae and coiled mouthparts that are adapted to siphoning sap and nectar from plant flowers. They can be bright- or dull-colored, and males and females of the same species do not always have the same coloration. Adult moths feed very little, if at all, and do not damage their host plant. Moth larvae (known as caterpillars) have a toughened head capsule, chewing mouthparts, and a soft body. They are active feeders, developing internally or externally on the host plant. The pupal stage of moths is known as a chrysalis and is often enclosed in a cocoon. The moth species used for toadflax biocontrol in North America belong to two families: the Noctuidae and the Cosmopterigidae.

Insects used for North American toadflax biocontrol attack different parts of the plant. They include two seed-feeding weevils, a flower-feeding beetle, two stem-mining weevils, a root-

galling weevil, a defoliating moth, and two root-boring moths. As such, roots, stems, flowers, seeds, and foliage are all attacked by the toadflax biocontrol agents. Toadflax biocontrol agents preferentially attack Dalmatian or yellow toadflax, but may survive to some degree on both species and potentially on their hybrids. Figure 28 illustrates the toadflax species and plant parts attacked by each biocontrol agent. Each insect is described in detail in the following sections, with separation between beetles and moths. All toadflax biocontrol agents already established in North America are summarized and compared in Tables 4-6 near the end of this chapter.

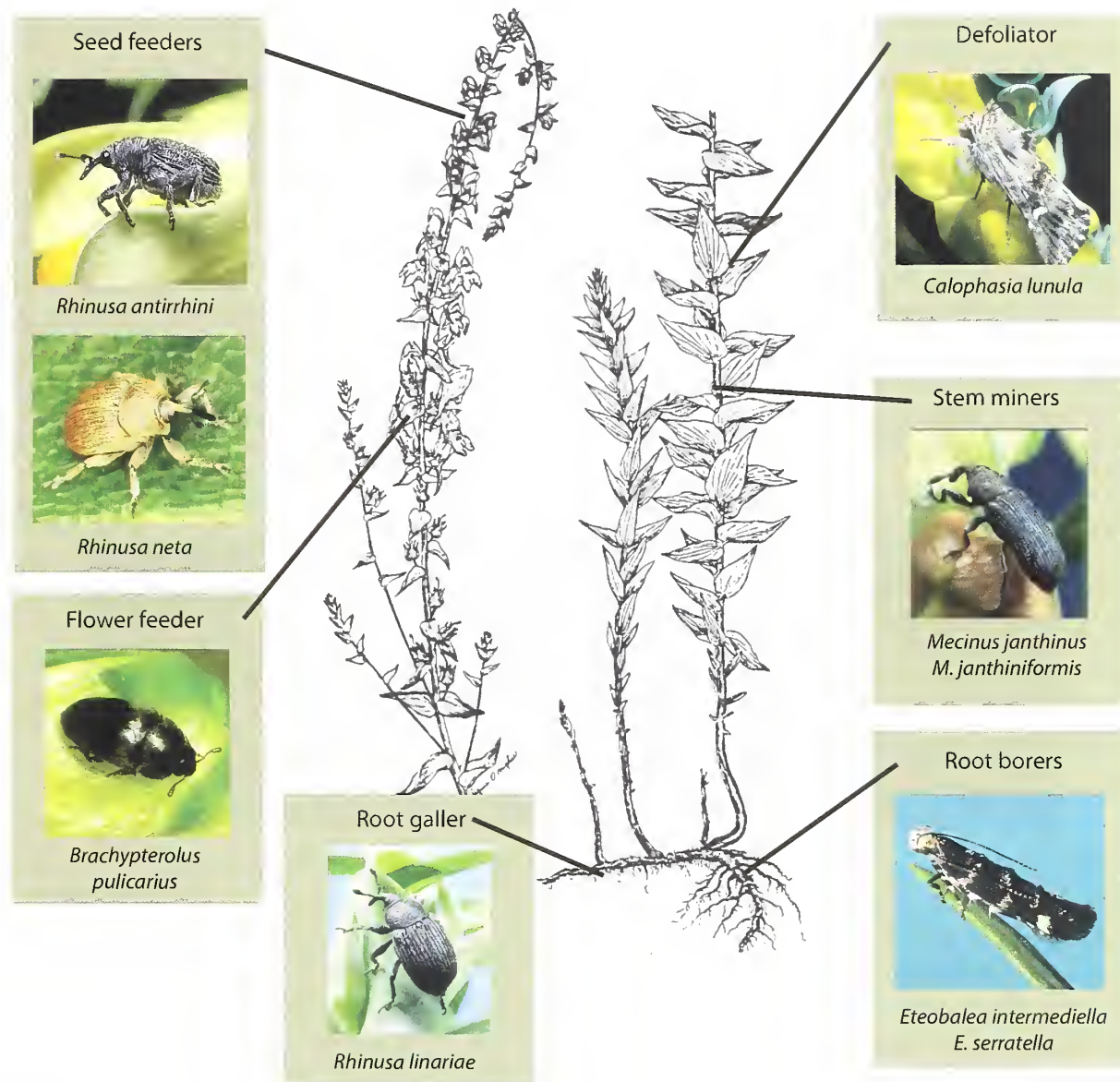

Figure 30. Generalized drawing of toadflax, including the biocontrol agents and the plant parts they attack. Note Most biocontrol agents can attack both Dalmatian and yellow toadflax but have a preference for one of the two species. *Rhinusa* spp., *Brachyterolus pulicarius*, *Eteobalea serratella*, and *Mecinus janthinus* prefer yellow toadflax; *E. intermediella* and *M. janthiniformis* prefer Dalmatian toadflax. All biocontrol agents listed above are able to attack hybrid toadflax. (Plant: modified from Regina O. Hughes, mtwow.org); *R. antirrhini* (Ivo Toševski, CABI); *R. neta* (Gyorgy Csoka, Hungary Forest Research Institute); *B. pulicarius* (Daniel K. MacKinnon, Colorado State University); *R. linariae*, *Mecinus* spp. (Bob Richard, USDA APHIS PPQ); *C. lunula* (Laura Parsons, University of Idaho); *E. intermediella* (Ivo Tosevski, CABI)

Brachyterolus pulicarius (L.)

Toadflax flower-feeding beetle

ORDER	Coleoptera
FAMILY	Kateretidae
NATIVE DISTRIBUTION	Europe
ORIGINAL SOURCE	USA: Accidental CAN: Accidental
FIRST RELEASE	USA: 1919 CAN: 1953
NONTARGET EFFECTS	None reported

Description

Eggs appear milky white at first, becoming yellow just before hatching. Larvae are yellow and up to 7 mm long. The larval head capsule starts out dark brown to black and wider than the abdomen, but by the third instar, lightens to a golden brown and becomes more slender than the body (Figure 31a). Pupae are up to 3 mm long and 2 mm wide. Adults are shiny, dark brown to black, or sometimes black with brown mottling. They are 2-3 mm long and somewhat oval-shaped (Figure 31b).

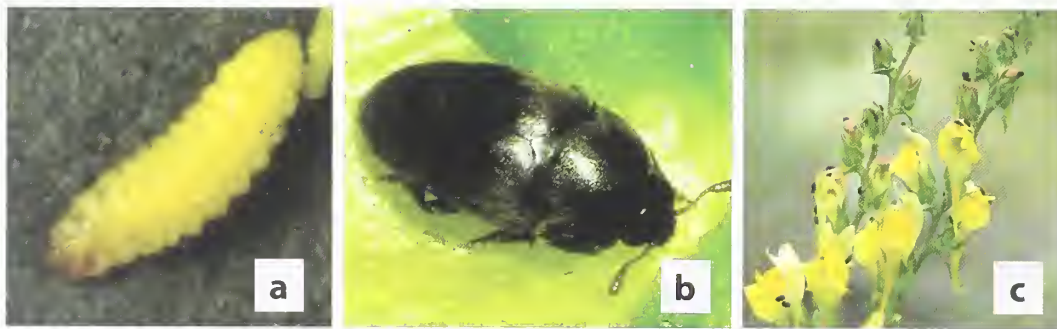

Figure 31. *Brachyterolus pulicarius* a. larva; b. adult (a,b Daniel K. MacKinnon, Colorado State University); c. adults on toadflax flowers and buds (Susan Turner, British Columbia Ministry of Forests) (a-c bugwood.org)

Life Cycle

Adults emerge in late spring and feed on young toadflax shoot tips and leaf buds. Females lay eggs singly into unopened toadflax buds, just beneath the folded petals. Larvae feed on flower pollen, anthers, ovaries, and immature seeds. They develop through three instars and drop to the soil in fall to overwinter as pupae in soil or plant litter. There is one generation per year.

Egg												
Larva												
Pupa												
Adult												
	Jan	Feb	Mar	Apr	May	Jun	Jul	Aug	Sep	Oct	Nov	Dec

Figure 32. Schematic life cycle of *Brachyterolus pulicarius*. Bars indicate the approximate length of activity for each life stage; dates will vary depending on local conditions. Black bars represent the inactive overwintering period.

Habitat Preference

The toadflax flower-feeding beetle is well adapted to a variety of environmental conditions and can be found throughout the majority of toadflax infestations in North America.

Damage

Adult feeding can delay flowering and reduce the number of healthy flowers (and thereby seeds) produced by yellow toadflax. At high densities, adult feeding increases branching and reduces the height of Dalmatian toadflax plants. Injury from larval feeding is generally more significant, reducing seed output by more than 75% in attacked flowers. Seeds surviving to maturity in attacked flowers are smaller, lighter weight, and less viable. Decreasing seed output does not kill existing plants but can help reduce the rate of spread and genetic diversity of toadflax populations.

Current Status and Availability

This beetle was unintentionally introduced. First reported on yellow toadflax in New York, it has spread naturally and via redistributions throughout North America on both yellow and Dalmatian toadflax. *Brachyterolus pulicarius* biotypes (or strains) were believed to have evolved to specialize on either yellow toadflax or Dalmatian toadflax; however, a recent study found no genetic basis for this claim. *B. pulicarius* prefers and performs better on yellow toadflax, even for individuals collected from Dalmatian toadflax. Its use of Dalmatian toadflax, therefore, remains incidental in both the USA and Canada.

On Dalmatian toadflax in the USA, high densities (such as those observed in Idaho, Oregon, and Washington) can stunt stem height and cause increased branching. However, the overall impact on Dalmatian toadflax flowering and seed production is considered minimal at most sites. *Brachyterolus pulicarius* is typically more abundant on yellow toadflax in the USA, delaying flowering and reducing seed production by 80-90% at some locations. However, the overall impact on yellow toadflax populations also appears to be minimal.

On yellow toadflax in Canada, *B. pulicarius* is abundant, but its overall impact has been limited. It delays flowering and seed production, but has not truly changed the scope or prevalence of problems associated with yellow toadflax. *B. pulicarius* is found sporadically on Dalmatian toadflax in Canada but appears to be too rare to have any major impact on seed production. The impacts of *B. pulicarius* on hybrid toadflax have not yet been studied in North America.

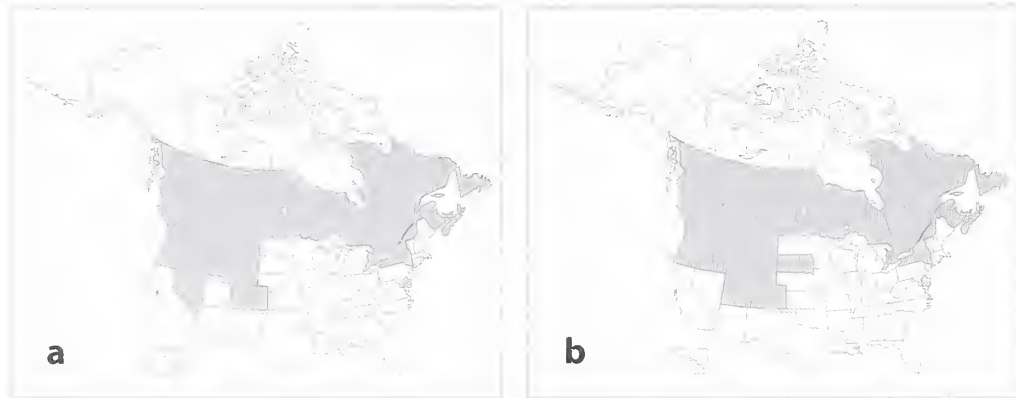

Figure 33. North American establishment of *Brachypterolus pulicarius* on a. Dalmatian toadflax; b. yellow toadflax. Note: *B. pulicarius* is anecdotally reported as established on yellow toadflax in other northeastern states in the USA not specified in the literature.

Comments

Though *B. pulicarius* was first an accidental introduction in the USA, it is approved for redistribution within North America. Because the beetle is already widespread and its overall impact is low, it is not a high priority for redistribution.

Adult *B. pulicarius* can be differentiated from the other toadflax beetle species by their lack of snouts; the other toadflax beetles are weevils and have long snouts. Competition between *Rhinusa antirrhini* and *Brachypterolus pulicarius* prevents both species from having an additive impact in many locations.

Adult *B. pulicarius* have been observed feeding on the pollen of many plant species, including dandelion, clovers, wild mustards, strawberry, apple, and dogwood. This feeding causes little to no impact.

Mecinus janthinus Germar

Yellow toadflax stem-mining weevil

Mecinus janthiniformis Toševski & Caldara

Dalmatian toadflax stem-mining weevil

<i>Mecinus janthinus</i>	
ORDER	Coleoptera
FAMILY	Curculionidae
NATIVE DISTRIBUTION	Eurasia
ORIGINAL SOURCE	USA: France, Germany CAN: France, Germany
FIRST RELEASE	USA: 1996 CAN: 1991
NONTARGET EFFECTS	None reported

<i>Mecinus janthiniformis</i>	
ORDER	Coleoptera
FAMILY	Curculionidae
NATIVE DISTRIBUTION	southeastern Europe
ORIGINAL SOURCE	USA: Macedonia via Canada CAN: Macedonia
FIRST RELEASE	USA: post 1996 CAN: 1992
NONTARGET EFFECTS	None reported

Description

These species are morphologically very similar. Eggs are white and oval-shaped. Larvae are C-shaped, creamy-white with brown head capsules, and are up to 5 mm long (Figure 34a). Adults are bluish-black (rarely greenish-black), elongated, and have long snouts (Figure 34c). Newly emerged adults may have a subtle metallic sheen that becomes more dull black with age. *Mecinus janthinus* adults are smaller (2.4-3.4 mm vs. 3.2-6.0 mm long, excluding snout) and their snouts are less abruptly curved than *M. janthiniformis*. Otherwise, these two species are nearly identical.

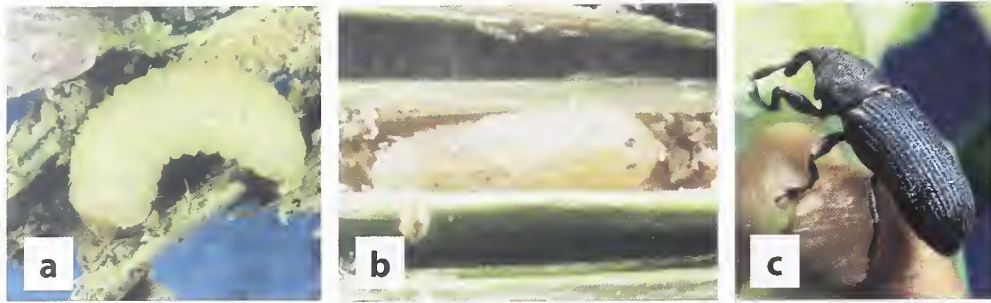

Figure 34. *Mecinus* spp. a. larva (Rosemarie De Clerck-Floate, Agriculture and Agri-Food Canada); b. pupa; c. adult. Top bar *M. janthinus*, bottom bar *M. janthiniformis* (b,c Bob Richard, USDA APHIS PPQ) (a-c bugwood.org)

Life Cycle

Overwintering adults emerge in early spring and feed on shoot tips. In the native range, *Mecinus janthinus* reportedly emerges a few weeks earlier on yellow toadflax than *M. janthiniformis* does on Dalmatian toadflax (Figure 35,36). Spring emergence of adult weevils in North America varies significantly due to the influence of site-specific characteristics such as latitude, elevation, aspect, and residual snow cover. Adult feeding on toadflax shoot tips and leaves produces a distinctive shot hole injury pattern, which tends to be more obvious on Dalmatian toadflax. Females chew holes into toadflax stems and lay eggs singly (up to 45 in a lifetime), covering eggs with chewed plant tissue. Larvae feed through three instars in short tunnels chewed inside the toadflax stems. *Mecinus janthinus* tends to mine lower in toadflax stems than *M. janthiniformis*. Pupation occurs in mid-summer in chambers located in the larval feeding tunnels. Development to adulthood occurs by late summer, with adults overwintering inside the pupal chambers. There is one generation per year, with all development from egg deposition to adult emergence the following spring taking place in the same toadflax stem.

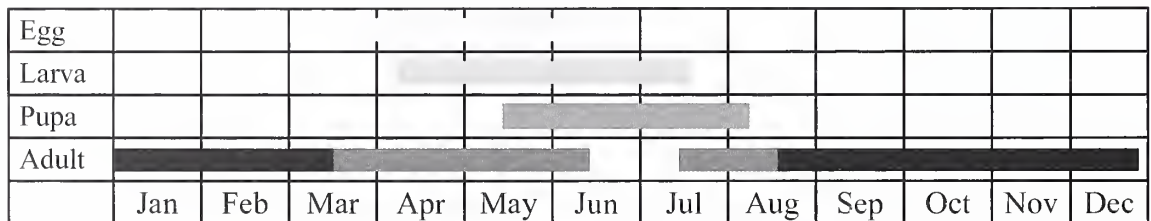

Figure 35. Schematic life cycle of *Mecinus janthinus*. Bars indicate the approximate length of activity for each life stage; dates will vary depending on local conditions. Black bars represent the inactive overwintering period.

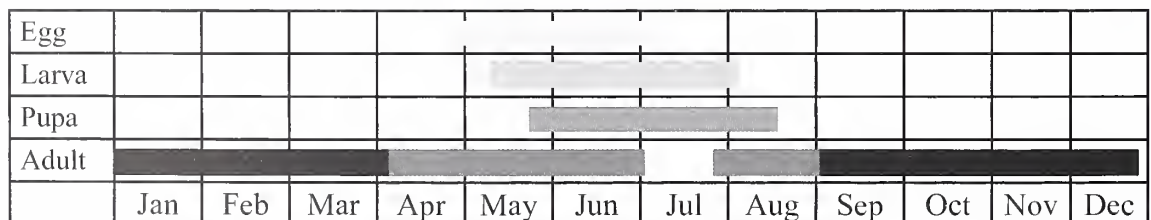

Figure 36. Schematic life cycle of *Mecinus janthiniformis*. Bars indicate the approximate length of activity for each life stage; dates will vary depending on local conditions. Black bars represent the inactive overwintering period.

Habitat Preference

Mecinus janthiniformis is well adapted to a variety of environmental conditions and can be found on many Dalmatian toadflax infestations in North America. The overwintering of adults within dead Dalmatian toadflax stems, which typically stand above snow cover, exposes the weevils to extremes in fluctuating ambient temperature and humidity. Adult mortality can reach 75 to 100% where temperatures drop lower than -18.5°F (-28°C); however, affected populations can rebound over time. *Mecinus janthinus* prefers milder, low-elevation sites in its native range compared to *M. janthiniformis*. The North American distribution and habitat preferences of *M. janthinus* are still being determined; however, successful yellow toadflax biological control with *M. janthinus* has been observed at elevations above 7,000 feet (2,180 m), and establishment so far has been confirmed at latitudes of up to 53.5°N in Northern Alberta, Canada.

Damage

Adult weevils consume/chew on the growing tips of toadflax shoots, stems, and leaves, producing a distinctive shot hole injury pattern (Figure 37a, 38a). This damage weakens the plant, can suppress flowering and seed production, and severely stunts shoots. Large aggregations of *M. janthiniformis* adults feeding on new toadflax shoot growth can result in significant injury to shoot tips and leaves; heavily attacked shoot tips may turn brown and shrivel. Larval mining (Figure 37c) severs water/nutrient-conducting tissues, causing desiccation and death (Figure 38b). Larval feeding also likely depletes nutrient reserves in the roots, which is important for the year-to-year persistence of individual plants. Repeated, yearly attack by both adults and larvae can lead to striking reductions in toadflax plant density.

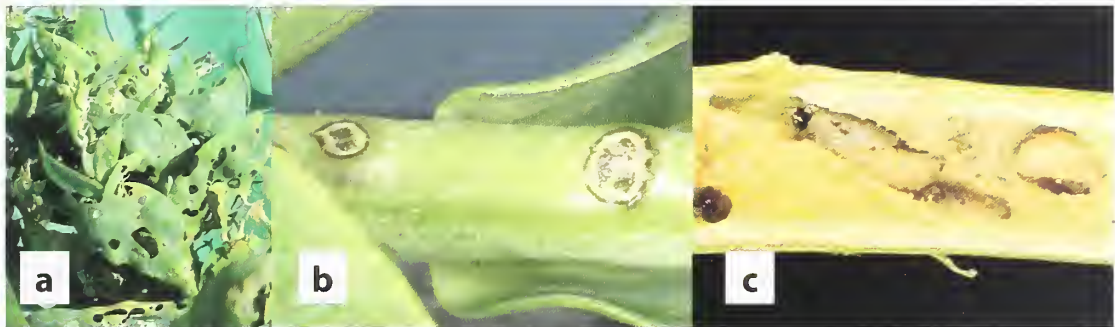

Figure 37. *Mecinus* spp. damage on Dalmatian toadflax a. adult feeding on leaves; b. oviposition scars (a,b Sharlene E. Sing USDA FS RMRS); c. larval mining (Laura Parsons, University of Idaho)



Figure 38. *Mecinus* spp. damage on yellow toadflax a. adult and feeding holes on foliage; b. plants dying from larval mining (a,b Sharlene E. Sing USDA FS RMRS)

Current Status and Availability

Agents originally released in the USA and Canada as *Mecinus janthinus* were recently discovered to be a mixture of *M. janthinus* and a closely related species, *M. janthiniformis*. Field surveys and lab-based experiments have determined that *M. janthiniformis* prefers Dalmatian toadflax. *Mecinus janthiniformis* is currently established in northwestern North America (Figure 39a), where it has reduced Dalmatian toadflax populations dramatically at some locations.

Surveys and studies have similarly found that *M. janthinus* prefers yellow toadflax. While currently not widely distributed (Figure 39b), *M. janthinus* densities and impact on yellow toadflax can be high locally, and this species appears to establish well in new areas. The impacts of *Mecinus* spp. on hybrid toadflax have not yet been fully determined.



Figure 39. North American establishment of a. *Mecinus janthiniformis* on Dalmatian toadflax; b. *Mecinus janthinus* on yellow toadflax; Note: because the identification of *M. janthiniformis* has only recently been made, sorting the establishment status of each *Mecinus* species on the two toadflax species is a work in progress in North America.

Comments

Mecinus spp. weevils are strong fliers and can easily disperse throughout toadflax-infested areas. Field observations showed that in southern British Columbia, *M. janthiniformis* was capable of spreading over 2 miles (3.2 km) in four years. *Mecinus janthinus* readily located isolated plants and small toadflax populations throughout an extensive area where it had become established in west-central Montana. Dalmatian toadflax has live prostrate stems that persist even under snow over winter, providing a food supply and little incentive for newly emerged adult *M. janthiniformis* to disperse in spring. Because there is no equivalent overwintering rosette produced by yellow toadflax, adult *M. janthinus* emerging in spring are left marooned without a food supply and readily disperse to seek out host plants.

Low rates of parasitism have been documented on *Mecinus* spp. in the USA and Canada. Adult *Mecinus* spp. can be differentiated from the other toadflax weevil species by their elongated shape, compared to the more rounded bodies of *Rhimusa* spp. Adult *Brachypterolus pulicarius* do not have the snouts of the *Mecinus* and *Rhimusa* weevils.

***Rhinusa antirrhini* (Paykull)**

Toadflax seed-galling weevil

Synonyms: *Gymnetron antirrhini* (Paykull), *Gymnaetron antirrhini* (Paykull)***Rhinusa neta* (Germar)**

Toadflax seed-feeding weevil

Synonyms: *Gymnetron netum* (Germar), *Gymnaetron netum* (Germar)

<i>Rhinusa antirrhini</i>	
ORDER	Coleoptera
FAMILY	Curculionidae
NATIVE DISTRIBUTION	Eurasia, Mediterranean
ORIGINAL SOURCE	USA: Accidental & former Yugoslavia CAN: 1917 accidental & former Yugoslavia
FIRST RELEASE	USA: 1909 accidental; 1996 intentional CAN: 1917 accidental; 1993 intentional
NONTARGET EFFECTS	None reported

<i>Rhinusa neta</i>	
ORDER	Coleoptera
FAMILY	Curculionidae
NATIVE DISTRIBUTION	Europe
ORIGINAL SOURCE	USA: Accidental CAN: Accidental
FIRST RELEASE	USA: 1937 CAN: 1957
NONTARGET EFFECTS	None reported

Description

Rhinusa antirrhini and *R. neta* are similar weevils attacking the seeds of toadflaxes in North America. *Rhinusa antirrhini* eggs are oval and flattened. Larvae are C-shaped, creamy yellow (Figure 40a) with dark brown head capsules, and are up to 4 mm long. Pupae are dark gray, typically 2.5 mm long, and have two tiny ‘horns’ protruding from the top of the thorax (see arrow in Figure 40b). Adults are gray to black and covered in dense, short hairs (Figure 40c). They have a long, distinctly curved, and pointed snout and a wide body. Adults collected from yellow toadflax are typically 2.5-3 mm long, while those developing on Dalmatian toadflax are up to 5 mm long.

Rhinusa neta eggs are oval and flattened. Larvae are C-shaped, creamy yellow with light brown head capsules, and are up to 4 mm long. Pupae are gray or brown, typically 3 mm long, and have two small bumps at the top of the thorax. Adults are gray or brown and covered in dense, short hairs (Figure 41a,b). Adult snouts are somewhat blunt and only slightly curved, and are not tapered or pointed. Adults are typically 3 mm long.

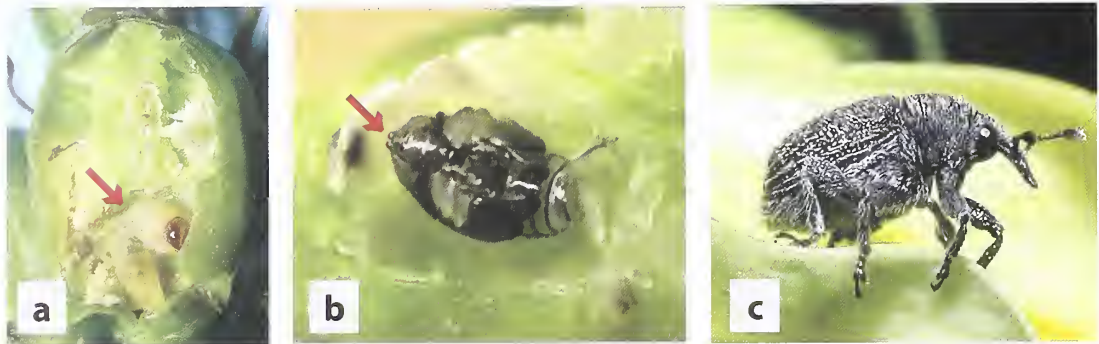

Figure 40. *Rhinusa antirrhini* a. arrow points to larva in seed capsule; b. pupa, arrow points to 'horns' on top of the thorax (© Arnold Grosscurt); c. adult (a,c Ivo Toševski, CABI)

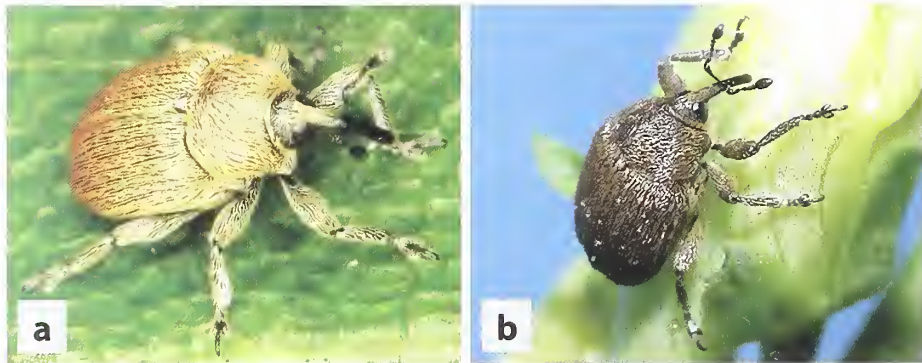

Figure 41. *Rhinusa neta* adults a. (Gyorgy Csoka, Hungary Forest Research Institute, bugwood.org); b. (Ivo Toševski, CABI)

Egg												
Larva												
Pupa												
Adult												
	Jan	Feb	Mar	Apr	May	Jun	Jul	Aug	Sep	Oct	Nov	Dec

Figure 42. Schematic life cycle of *Rhinusa antirrhini* and *R. neta*. Bars indicate the approximate length of activity for each life stage; dates will vary depending on local conditions. Black bars represent the inactive overwintering period.

Habitat Preference

The overall habitat preferences of *R. antirrhini* and *R. neta* are unknown. *Rhinusa antirrhini* is distributed throughout most yellow toadflax infestations in North America, indicating it is well adapted to a variety of conditions.

Damage

Rhinusa antirrhini

Adult feeding (Figure 43a) is typically insignificant. Female's egg deposition triggers the development of a spur (bump) on the seed capsule (sec arrow, Figure 43b). The growing spur pushes the *R. antirrhini* egg into the developing toadflax seeds, triggering the formation of a gall. The gall causes the 8-17 seeds closest to the egg to grow up to 10 times their normal size and turn a watery, pale yellow color. As a result, attacked capsules can be easily identified (Figure 43c). Abnormal seeds are not viable, and larval feeding destroys additional seeds within attacked capsules.

Rhinusa neta

Adult feeding is typically insignificant. While oviposition and feeding by *R. neta* does not cause seed swelling, a single larva can consume a high proportion of seeds in the capsule. For both species, at densities of more than two larvae per capsule, all viable seeds in an attacked capsule can be destroyed. Decreasing seed output does not kill existing plants but can help reduce the rate of spread and genetic diversity of toadflax populations.

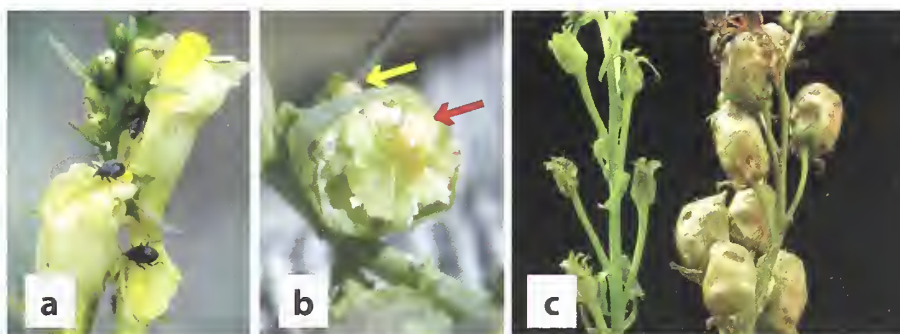

Figure 43. *Rhinusa antirrhini* a. adults on flowers (Eric Coombs, Oregon Department of Agriculture, bugwood.org); b. larvae in seeds, yellow arrow points to 'spur' while red arrow points to a larva (Eric Coombs, Oregon Department of Agriculture, bugwood.org); c. galled, swollen seed capsules of yellow toadflax (right) and normal seed capsules (left) (© Arnold Grosscurt)

Current Status and Availability

Rhinusa antirrhini

This beetle (yellow toadflax biotype) was unintentionally introduced. First reported on yellow toadflax in Massachusetts, it has spread naturally and via redistributions throughout North America on both yellow and Dalmatian toadflax. An additional strain (Dalmatian biotype) was intentionally introduced from former Yugoslavia and released against Dalmatian toadflax in Canada and the USA from 1993.

Rhinusa antirrhini is established on Dalmatian toadflax in the USA and Canada (Figure 44a), but it is not as abundant as *R. antirrhini* on yellow toadflax, and its host impacts have not been studied. *Rhinusa antirrhini* is well established on yellow toadflax throughout the USA and Canada (Figure 44b). Larval feeding destroys some seeds in attacked capsules, and seed reductions between 85 and 90% have been reported in Washington; however, seed reduction is typically much lower. Attack rates from 30-40% in Oregon had minimal impacts on plant

density. In Canada, widespread distribution of *R. antirrhini* has yet to lead to satisfactory control. It is believed that the overall impact of *R. antirrhini* on yellow toadflax is limited, and likely also limited on Dalmatian toadflax.

The impacts of *R. antirrhini* on hybrid toadflax have not yet been studied in North America.

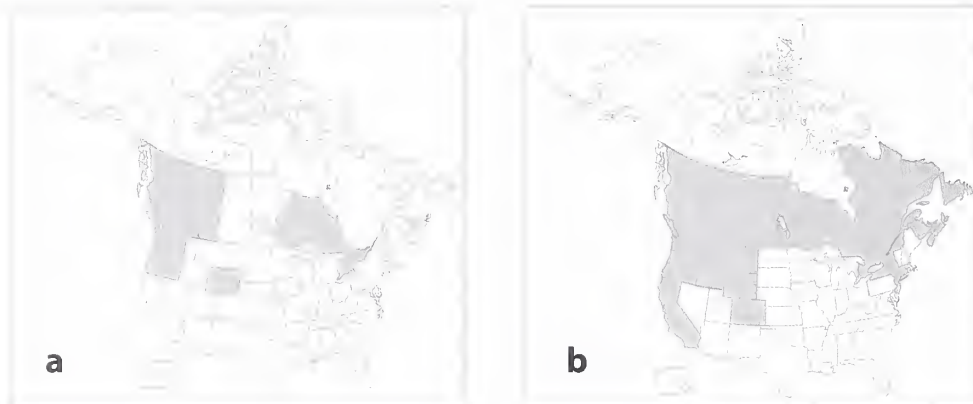

Figure 44. North American establishment of *Rhinusa antirrhini* on a. Dalmatian toadflax; b. yellow toadflax. Note: *R. antirrhini* is established on yellow toadflax in other northeastern and northwestern states in the USA not specified in the literature (where yellow toadflax is established) and has yet to be fully assessed for current distribution within Canada.

Rhinusa neta

This beetle was unintentionally introduced and found on both Dalmatian and yellow toadflax in the northeastern USA, and it is now established other parts of North America on both yellow and Dalmatian toadflax (Figure 45a,b). In the USA, it occurs on both toadflaxes in several eastern states and at least Washington in the Northwest, but only in scattered populations. In Canada, it is more widespread on yellow toadflax, but only found sporadically on Dalmatian toadflax. In both countries, *R. neta* prefers yellow toadflax over Dalmatian toadflax. Larval feeding destroys a high proportion of seeds in attacked capsules, though overall attack rates on yellow toadflax are typically limited in the USA. Even in Canada, where yellow toadflax attack rates are higher, satisfactory control has yet to be achieved.

The impacts of *R. neta* on hybrid toadflax have not yet been studied in North America.

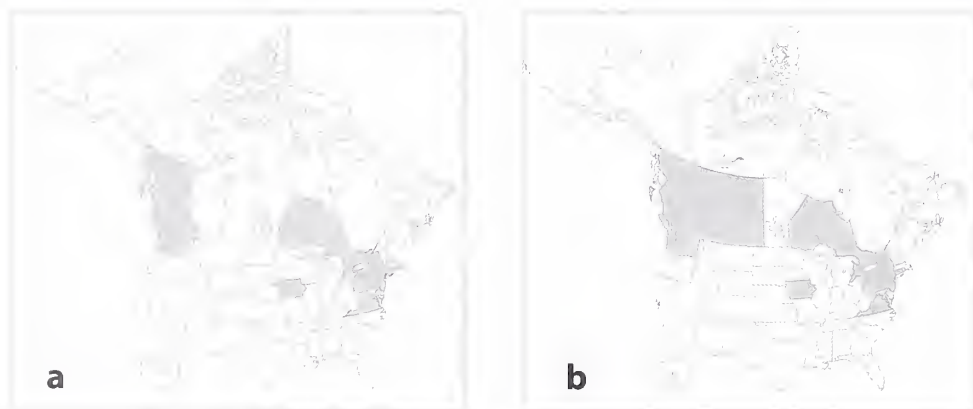

Figure 45. North American establishment of *Rhinusa neta* on a. Dalmatian toadflax; b. yellow toadflax.

Comments

At least one parasitic wasp species has been reported to attack *R. antirrhini* in the USA. Competition between *Brachypterolus pulicarius* and *Rhinusa antirrhini*/*R. neta* prevents these species from having an additive impact in many locations.

Rhinusa antirrhini pupae have tiny ‘horns’ that are more pronounced than the small bumps on *R. neta*. Adult *R. antirrhini* have a more pointed and curved snout than *R. neta* and are dark grayish-black while *R. neta* adults are a lighter gray to brown. Both *R. antirrhini* and *R. neta* differ from *R. linariae* in their location of attack (adults attack flowers and shoot tips and larvae attack seeds while *R. linariae* adults attack stems and larvae attack roots). *Mecinus* spp. adults have more elongated bodies compared to *Rhinusa* spp. Adult *Brachypterolus pulicarius* do not have the snouts of the *Mecinus* and *Rhinusa* weevils.

Though *R. antirrhini* was first an accidental introduction in the USA, it is approved for redistribution within North America. Because this weevil is already widespread and its overall impact is low, it is not a high priority for redistribution. *Rhinusa neta* is not approved for redistribution in the USA.

Rhinusa linariae Panzer

Toadflax root-galling weevil

Synonyms: *Gymnetron linariae* (Panzer)

ORDER	Coleoptera
FAMILY	Curculionidae
NATIVE DISTRIBUTION	Europe
ORIGINAL SOURCE	USA: Germany CAN: central southern Europe, Russia
FIRST RELEASE	USA: 1996 CAN: 1996
NONTARGET EFFECTS	None reported

Description

Eggs are pale yellow, smooth surfaced, and pear-shaped (Figure 46a). Larvae are C-shaped, creamy white with brown head capsules, and are up to 4 mm long. Pupae are dark gray and typically 2.5 mm long. Adults are small and black with pronounced, curved snouts (Figure 46b). They are covered in dense, short hairs.

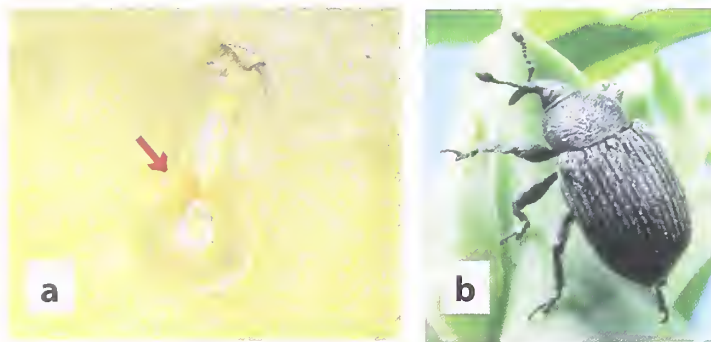

Figure 46. *Rhinusa linariae* a. egg position inside of a root gall on yellow toadflax (note arrow) (Ivo Toševski, CABl) ; b. adult (Bob Richard, USDA APHIS PPQ, bugwood.org)

Life Cycle

Overwintering adults emerge in spring and feed on new toadflax shoots, consuming stem tissue and sap. Females lay eggs singly into pockets chewed into toadflax roots and root crowns, triggering gall formation. Larvae feed on galled root tissue through three instars. Pupation occurs in galls with new adults emerging in mid- to late summer. Adults often feed briefly on toadflax stems and then overwinter in soil or plant litter. Some new, fully developed adults remain within the root galls throughout the fall and winter, and do not emerge until the following spring. There is one generation per year (Figure 47).

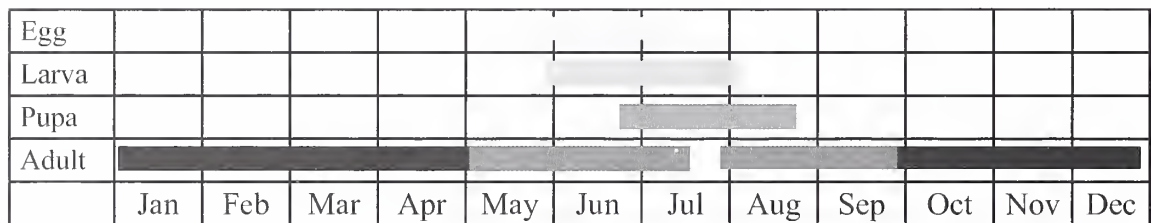

Figure 47. Schematic life cycle of *Rhinusa linariae*. Bars indicate the approximate length of activity for each life stage; dates will vary depending on local conditions. Black bars represent the inactive overwintering period.

Habitat Preference

The overall habitat preferences of *R. linariae* in North America are unknown because confirmed established populations are restricted to limited sites in British Columbia. In Europe, *R. linariae* does well in grassland habitats, is rarely found in subalpine habitats, and is absent from alpine zones.

Damage

In European field studies, between 20 and 100 galls per plant were found on the roots of attacked yellow toadflax. Adjacent individual root galls can fuse into gall complexes comprised of up to 40 individual galls (Figure 48a,b). Root galls disrupt the transport of nutrients and water to and from the roots. Root galls may also act as a metabolic sink, directing root nutrients to the developing galls and ultimately to the *R. linariae* larvae that feed on the gall tissues, therefore robbing the toadflax plant of essential nutrients for normal plant growth. Although significant gall development can occur, it is not yet known what impact, if any, this agent is having on Dalmatian or yellow toadflax populations in the United States and Canada because of its limited confirmed establishment to date.

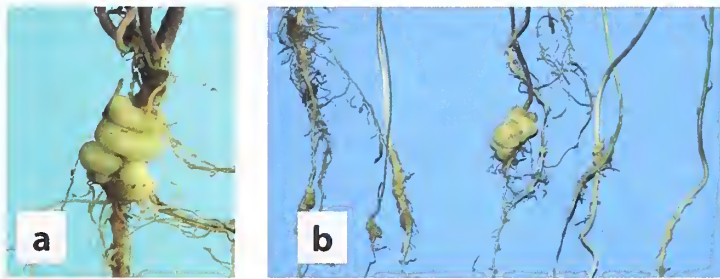

Figure 48. *Rhinusa linariae* galls on yellow toadflax roots a,b (Ivo Toševski, CABI)

Current Status and Availability

After the initial USA introductions failed to establish, a population from British Columbia was redistributed to Colorado in 2008. This introduction failed as well. Another redistribution attempt was made in 2015, though it is too soon to know the fate of this release. To date, *R. linariae* is confirmed as established at a limited number of sites only in British Columbia and only on yellow toadflax (Figure 49a,b). Because populations are slow to build, redistributions are made whenever possible. Adult foliage feeding and larval galling are known to reduce plant nutrient reserves; however, current populations are too low to have a significant impact on yellow toadflax populations. The impacts of *R. linariae* on hybrid toadflax have not yet been studied in North America.

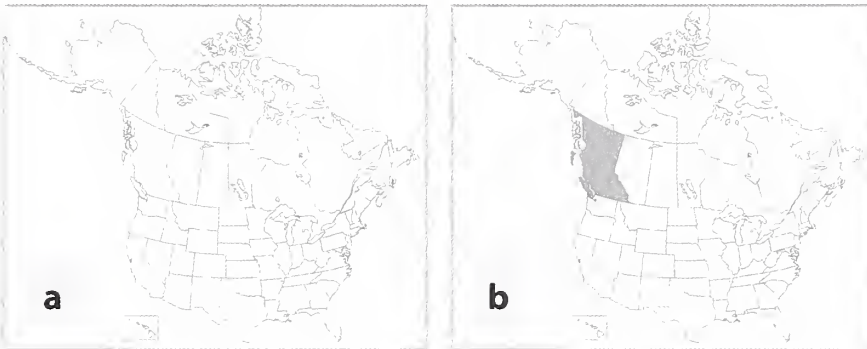

Figure 49. North American establishment of *Rhinusa linariae* on a. Dalmatian toadflax (not established); b. yellow toadflax

Comments

Rhinusa linariae can be differentiated from the other toadflax *Rhinusa* beetles by the location of attack on host plants. *Rhinusa linariae* adults attack toadflax stems, and their larvae attack the roots; *R. antirrhini*/*R. neta* adults attack toadflax flowers and shoot tips, and their larvae attack the seeds. In addition, *R. linariae* has a more pointed and curved snout than *R. neta* and is black while *R. neta* is gray to brown. *Mecinus* spp. adults have more elongated bodies compared to *Rhinusa* spp. Adult *Brachypterolus pulicarius* do not have the snouts of the *Mecinus* and *Rhinusa* weevils.

Calophasia lunula (Hufnagel)

Toadflax defoliating moth

ORDER	Lepidoptera
FAMILY	Noctuidae
NATIVE DISTRIBUTION	Eurasia
ORIGINAL SOURCE	USA: Switzerland via Canada CAN: Switzerland and former Yugoslavia
FIRST RELEASE	USA: 1968 CAN: 1962
NONTARGET EFFECTS	Multiple species

Description

Eggs are pale yellow, strongly ribbed, and slightly conical. Larvae (caterpillars) are gray initially but have vivid black and yellow stripes with white spots at the final instar (Figure 50a). Final instar larvae reach a maximum length of 4.6 cm. Pupae are reddish-brown or golden brown within green cocoons (Figure 50b). Adults are a mottled gray-brown with light and dark markings on the wings (Figure 50c) and are 1-1.5 cm long with a wingspan of 2.5-3 cm.



Figure 50. *Calophasia lunula*: a. larva; b. cocoon (Gary Piper, Washington State University, bugwood.org); c. adult. Top bar length of body, bottom bar wingspan (a,c Laura Parsons & Mark Schwarzländer, University of Idaho)

Life Cycle

Adult moths emerge in late spring and feed on the nectar of toadflaxes and other plant species. Females lay an average of 100 eggs singly on toadflax foliage and, less frequently, on toadflax flowers. Larvae feed on young, tender leaves but will consume older and tougher lower stem leaves as plants become increasingly defoliated. Larvae nearing the end of the fifth instar move to the base of toadflax plants and spin cocoons of silk, chewed leaves, and soil that they attach to stem bases, plant litter, or soil. There are 1-3 generations per year, depending on weather conditions and the length of the growing season. At northern latitudes and high elevations, 1-2 generations are most common; three may occur in warmer locales, at lower elevations, and in regions with longer growing seasons. The moth overwinters as a pupa within the cocoon.

Egg												
Larva												
Pupa												
Adult												
	Jan	Feb	Mar	Apr	May	Jun	Jul	Aug	Sep	Oct	Nov	Dec

Figure 51. Schematic life cycle of *Calophasia lunula*. Bars indicate the approximate length of activity for each life stage; dates will vary depending on local conditions. Black bars represent the inactive overwintering period. There are 1-3 generations per year, but most frequently 1-2 in North America.

Habitat Preference

Calophasia lunula prefers warm, dry sites with coarse-textured soils. Establishment can be limited in cold climates, at northern latitudes, and at high elevations. Caterpillars are most often found in relatively sparse toadflax infestations.

Damage

Severe defoliation of seedlings and one-year-old plants can be fatal; older, larger plants can usually rebound from defoliation, although defoliated plants are less vigorous and may produce fewer flowers. Complete defoliation of an entire patch of toadflax by this moth has not been documented.

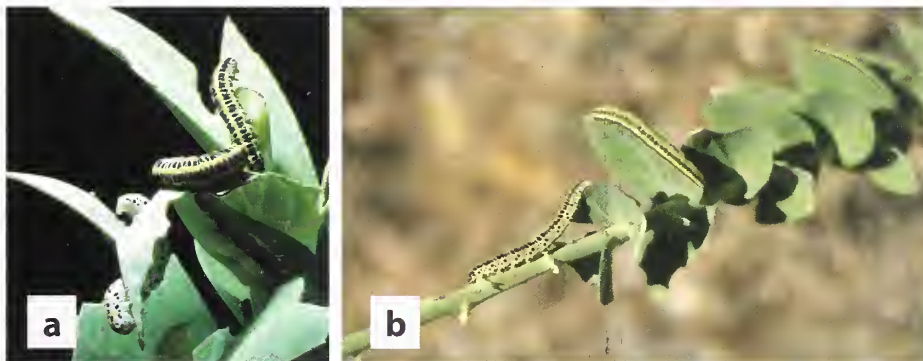

Figure 52. *Calophasia lunula* damage: a. larvae feeding on Dalmatian toadflax leaves (Laura Parsons & Mark Schwarzländer, University of Idaho); b. larvae defoliating a Dalmatian toadflax stem (Susan Turner, British Columbia Ministry of Forests)(a,b bugwood.org)

Current Status and Availability

Although population densities are typically low, this species occurs consistently on both Dalmatian and yellow toadflax infestations throughout much of the USA. Localized population explosions occasionally occur. Feeding by high densities of early instar *C. lunula* larvae can cause substantial patch defoliation. Overall, larval feeding typically decreases leaf area but does not disrupt the photosynthetic capacity sufficiently to have a significant impact on attacked plants.

Calophasia lunula is established on both yellow and Dalmatian toadflax in southern parts of Canada (Figure 53a,b), but its spread north is limited by the colder climates, and its impact is limited for the same reasons as in the USA. Parasitism may also limit populations in some parts of Canada. The impacts of *C. lunula* on hybrid toadflax have not yet been studied in North America.

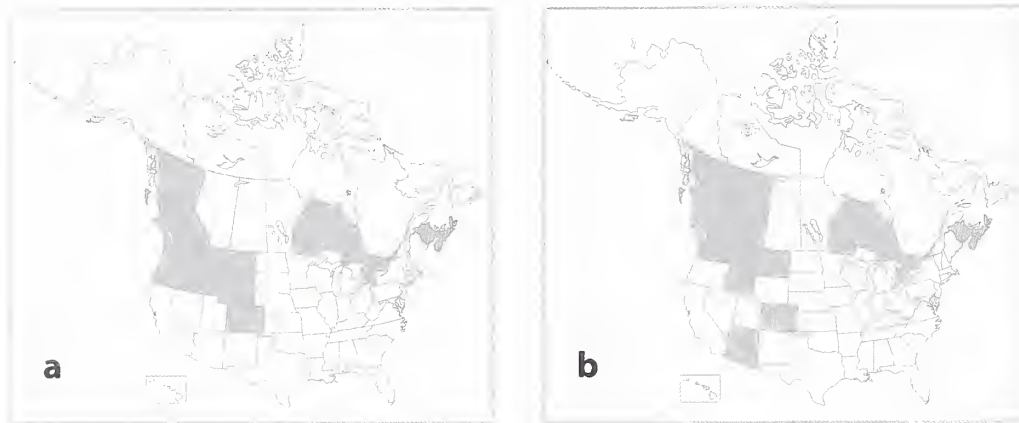

Figure 53. North American establishment of *Calophasia lunula* on a. Dalmatian toadflax; b. yellow toadflax.

Comments

Populations may be limited by parasitism, predation, and pathogen outbreaks in some locations.

Calophasia lunula caterpillars are known to feed and develop on plants related to toadflaxes, including non-native ornamentals and one native North American species, *Sairocarpus virga*. Because *C. lunula* poses a risk to nontarget plant species in the USA, some land managers have ceased collecting and redistributing this defoliating moth. **Caution should be taken during its redistribution, especially in areas with desirable snapdragon species present.**

Eteobalea intermediella Riedl.

Dalmatian toadflax root-boring moth

Eteobalea serratella Treitschke

Yellow toadflax root-boring moth

<i>Eteobalea intermediella</i>	
ORDER	Lepidoptera
FAMILY	Cosmopterigidae
NATIVE DISTRIBUTION	Southern Europe
ORIGINAL SOURCE	USA: former Yugoslavia CAN: Serbia
FIRST RELEASE	USA: 1996 CAN: 1991
NONTARGET EFFECTS	None reported

<i>Eteobalea serratella</i>	
ORDER	Lepidoptera
FAMILY	Cosmopterigidae
NATIVE DISTRIBUTION	Southern Europe
ORIGINAL SOURCE	USA: Italy CAN: Italy
FIRST RELEASE	USA: 1996 CAN: 1992
NONTARGET EFFECTS	None reported

Description

These species are very similar in appearance, differing most obviously in the surface texture of their eggs. The pattern on the surface of *E. intermediella* eggs is netlike while the surface of *E. serratella* eggs has a ridged appearance, marked by fine parallel lines or furrows (Figure 54). Larvae (caterpillars) are cream-colored with brown head capsules and are up to 12 mm long (Figure 55a). Adults are slender, 8-10 mm long, and are black with white and yellow spots (Figure 55c).

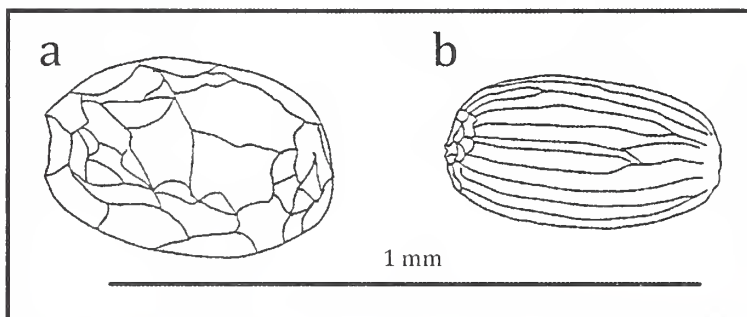

Figure 53. *Eteobalea* eggs a. *E. intermediella*; b. *E. serratella*



Figure 55. *Eteobalea* spp. a. *E. intermediella* larva; b. *E. intermediella* pupa (both a,b in Dalmatian toadflax root); c. *E. intermediella* adult; *E. serratella* adult (Ivo Toševski, CABI)

Life Cycle

Adults of both species emerge in late spring and live for only a few weeks. Adult moths are active from dawn to dusk and do not feed; they spend their entire adulthood mating and laying eggs. *Eteobalea intermediella* lays eggs in loose strings of 3-8 in the lower leaf axils or on the base of yellow toadflax and non-flowering Dalmatian toadflax stems. *Eteobalea serratella* lays eggs in loose strings of 3-8 at the base of yellow toadflax stems or on the soil surface. Adult females of both species can lay up to 180 eggs. Hatching larvae bore into the root crown where they feed on tissue inside tunnels they carve and line with silk. Larvae develop through five instars. Mature larvae tunnel back to the root crown or up into the base of a stem to construct a cocoon in which to pupate. *Eteobalea serratella* has one generation per year (Figure 56), overwintering as larvae in the roots and pupating the following spring. In contrast, *E. intermediella* typically has two generations per year (Figure 57). New adults emerge in mid-summer, quickly mate, and lay eggs. Larvae of this second generation feed inside toadflax roots through the fall and winter. Both species pupate within silken cocoons the following spring, and adults emerge through a small hole in the base of the stem.

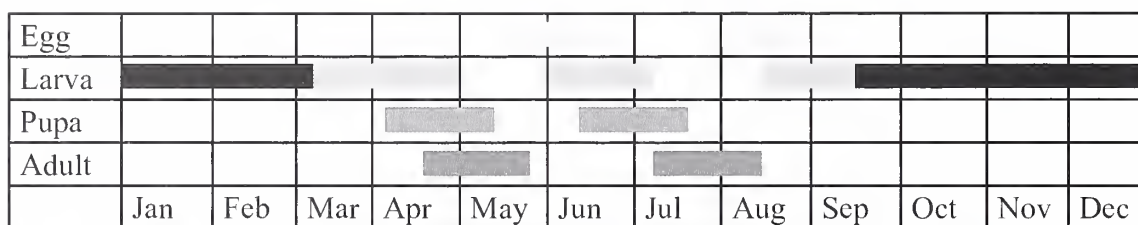

Figure 56. Schematic life cycle of *Eteobalea intermediella*. Bars indicate the approximate length of activity for each life stage; dates will vary depending on local conditions. Black bars represent the overwintering period. There are typically two generations per year.

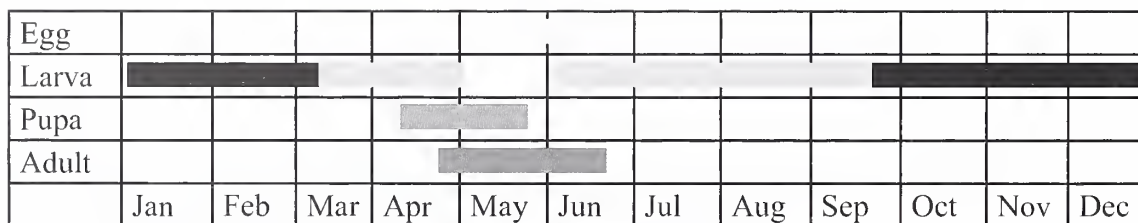

Figure 57. Schematic life cycle of *Eteobalea serratella*. Bars indicate the approximate length of activity for each life stage; dates will vary depending on local conditions. Black bars represent the overwintering period.

Habitat Preference

The overall habitat preferences of *Eteobalea intermediella* and *E. serratella* in North America are unknown because neither species is known to have established.

Damage

The impact of both root-boring moths on toadflax is similar. In studies conducted in Europe, three to seven larvae can be found within a single root of a toadflax plant, depending on the size of the roots. Root tunneling and boring by moth larvae does not usually kill toadflax plants directly. However, attacked plants are generally less vigorous, have fewer flowers, and produce fewer seeds than unattacked plants (Figure 58).





Current Status and Availability

Despite multiple introductions, neither species is known to have established on toadflaxes in North America.



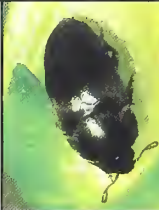

Figure 58. *Eteobalea serratella* damage to yellow toadflax (reddish brown dying stems) (Ivo Tosevski, CABI)

Table 4. Traits of biological control beetles introduced against toadflaxes in North America. Underlined plant species is preferred host.

BIOLOGICAL CONTROL AGENT	SPECIES ATTACKED	GENERATIONS/YEAR	OVERWINTERING STAGE, LOCATION	ADULT	EGG	LARVA	PUPA
<i>Brachypterosus pulicarius</i> Toadflax flower-feeding beetle	Dalmatian, <u>Yellow</u>	One	Pupae in soil or plant litter		Milky white; becoming yellow	Yellow; brown head capsules; up to 7 mm long	Up to 3mm long and 2 mm wide
<i>Mecinus janthinus</i> Yellow toadflax stem-mining weevil	<i>M. janthinus</i> : Dalmatian, <u>Yellow</u> <i>M. janthiniformis</i> : <u>Dalmatian</u> , <u>Yellow</u>	One	Adults inside stems		White; oval	C-shaped; creamy-white; brown head capsules; up to 5 mm long	Creamy-white; 3-5 mm long
<i>Mecinus janthiniformis</i> Dalmatian toadflax stem-mining weevil	<u>Dalmatian</u> , <u>Yellow</u>	One	Adults in soil or plant litter; less commonly adults remain in seed capsules		Oval; flattened	C-shaped; creamy-yellow; dark brown head capsules; up to 4 mm long	Dark gray; typically 2.5 mm long; 2 tiny 'horns' on top of thorax
<i>Rhinusa antirrhini</i> Toadflax seed-galling weevil	Dalmatian, <u>Yellow</u>	One	Adults in soil; less commonly adults remain in root galls		Pale yellow; smooth-surfaced; pear-shaped	C-shaped; creamy white; brown head capsules; up to 4 mm long	Dark gray; typically 2.5 mm long
<i>Rhinusa linariae</i> Toadflax root-galling weevil	Dalmatian, <u>Yellow</u>	One	Adults in soil or plant litter; less commonly adults remain in seed capsules		Oval; flattened	C-shaped; creamy yellow; light brown head capsules; up to 4 mm long	Gray or brown; typically 3 mm long; 2 tiny rounded bumps on top of thorax

Brachypterosus pulicarius (Daniel K. MacKinnon, Colorado State University); *Mecinus* spp. (Bob Richard, USDA APHIS PPQ); *Rhinusa antirrhini* (Ivo Toševski, CABI); *Rhinusa linariae* (Bob Richard, USDA APHIS PPQ); *Rhinusa neta* (Gyorgy Csoka, Hungary Forest Research Institute)

Table 5. Traits of biological control moths introduced against toadflaxes in North America. Underlined plant species is preferred host.

BIOLOGICAL CONTROL AGENT	SPECIES ATTACKED	GENERATIONS/YEAR	OVERWINTERING STAGE, LOCATION	ADULT	EGG	LARVA	PUPA
<i>Calophasia lunula</i> Toadflax defoliating moth	Dalmatian, Yellow	One or two most typically; three in some warm locations with long growing seasons	Pupae within cocoons attached to toadflax stem bases, plant litter or soil		Pale yellow; strongly ribbed; slightly conical	Gray initially; older larvae with black and yellow stripes and white spots; up to 4.6 cm long	Reddish- to golden-brown within green cocoons
<i>Eteobalea intermedia</i> Dalmatian toadflax root-boring moth	<u><i>E. intermedia</i></u> Dalmatian, Yellow	<i>E. intermedia</i> Typically two	Larvae in roots		<i>E. intermedia</i> : surface pattern netlike; <i>E. serratella</i> : surface pattern furrowed with ridges	Cream-colored; brown head capsules; up to 12 mm long	Slender; black with white and yellow spots; 8-10 mm long
<i>Eteobalea serratella</i> Yellow toadflax root-boring moth	<i>E. serratella</i> ; Dalmatian, <u>Yellow</u>	One					

Calophasia lunula (Laura Parsons & Mark Schwarzländer, University of Idaho); *Eteobalea intermedia* (Ivo Toševski, CABI)

Table 6. Comparison of established toadflax biocontrol agent activity according to toadflax growth stage (plant and agent stages will vary by climate and location).

Month	Dalmatian toadflax life stage	Yellow toadflax life stage	<i>Brachypterus pulicarius</i>	<i>Calophasia humula</i>	<i>Mecinus janthinus</i>	<i>Mecinus janthiniformis</i>	<i>Rhinusa antirrhini R. neta</i>	<i>Rhinusa linariae</i>
January	Prostrate stems overwinter; seeds continue to disperse from previous year's stems;	Seeds continue to disperse from previous year's stems; new shoots begin sprouting at warm sites	Pupae overwinter in soil or plant litter	Pupae overwinter in cocoons attached to toadflax stem bases, plant litter, or soil	Adults overwinter within previous year's toadflax stems	Adults overwinter within toadflax root	Adults overwinter in soil or plant litter; less commonly adults overwinter within toadflax root galls	
February								
March	New shoots sprout from buds on root crown; seeds germinate; flowers begin to form	Warm sites: shoots sprout from buds on lateral roots; seeds germinate Colder sites; shoots sprout, seeds germinate; All sites: stems elongate, flowers begin to form	Adults emerge and feed on young toadflax: eggs are laid in young toadflax buds	Adults emerge and lay eggs inside toadflax stems; new larvae feed on toadflax tissue inside short chewed tunnels	At warmer sites, adults begin to emerge, feed on young toadflax and lay eggs inside toadflax stems; new larvae feed on toadflax tissue inside short chewed tunnels	Adults emerge and feed on young toadflax	Adults emerge and feed on young toadflax; adults lay eggs into toadflax root crowns, triggering gall formation	
April								
May								
June	Flowers form	Flowers form	Adult emergence and egg laying continue; new larvae feed on floral/seed tissue	New larvae feed on toadflax foliage (young leaves attacked first)	Adults continue to emerge at colder sites; Larvae continue feeding within toadflax stems; pupation begins	Adults continue to emerge at colder sites; larvae continue feeding within toadflax stems; pupation begins	Adults lay eggs inside developing toadflax flowers; new larvae feed on seed tissue	New larvae feed on toadflax galled root tissue
July								

Table 6 continued. Comparison of established toadflax biocontrol agent activity according to toadflax growth stage (plant and agent stages will vary by climate and location).

Month	Dalmatian toadflax life stage	Yellow toadflax life stage	<i>Brachypterochus pullicarius</i>	<i>Calophasia humula</i>	<i>Mecinus janthinus</i>	<i>Mecinus janthiniiformis</i>	<i>Rhiiusa antirrhini R. neta</i>	<i>Rhiiusa lineariae</i>
August	Flowers and seeds mature; senescence begins; prostrate stems sprout	Flowers and seeds mature; senescence begins	Larvae continue feeding on floral and seed tissue	Pupation occurs in cocoons near plant bases; new adults begin emerging/ laying eggs	New adults emerge in pupal cells, but remain within toadflax stems	New adults emerge in pupal cells, but remain within toadflax stems	Larvae continue feeding on seed tissue; pupation begins in seed capsules	Pupation occurs in toadflax root galls
September			Larvae drop to the soil to pupate	New larvae feed on toadflax leaves			Pupation finishes; adults emerge from seed capsules to overwinter in soil or plant litter	Adults emerge from root galls, feed briefly on toadflax stems, and overwinter in soil or plant litter
October					Adults overwinter within toadflax stems	Adults overwinter within toadflax stems		Adults overwinter in soil or plant litter; less commonly adults overwinter within toadflax root galls
November	Upright stems die back; prostrate stems overwinter; seeds on current-year stems disperse	Stems die back; seeds on current-year stems disperse	Pupae overwinter in soil or plant litter	Pupation occurs in cocoons near plant bases; pupae overwinter				
December								

Prospective Toadflax Biological Control Agents

(Not available as of the publication of this manual, but may become available soon)

Several potential toadflax biocontrol agents are currently undergoing testing to determine their suitability for release in North America. These include five stem-galling weevils.

Mecinus spp.

(Coleoptera, Curculionidae)

Three additional species of *Mecinus* weevils are currently being evaluated overseas by CABI as potential toadflax biocontrol agents. All three closely resemble the currently established *M. janthinus* and *M. janthiniformis*, but differ in two significant aspects of their life history. Eggs laid by the three candidate *Mecinus* species cause the stem to swell and produce a semi-gall in which the larva feeds; *Mecinus janthinus* and *M. janthiniformis* larval feeding is not similarly confined to a gall, so their feeding tunnels are significantly longer. *M. janthinus*/*M. janthiniformis* adults overwinter in toadflax stems, whereas the candidate *Mecinus* species overwinter as adults in the soil. This difference may aid the overwintering success of the new species because they are at a lower risk of temperature fluctuations, drying out, and injury from wind and animals. Additional traits of all three weevils are given below.

Mecinus heydenii Wencker

Yellow toadflax stem-galling weevil

Mecinus heydenii has been collected only from yellow toadflax in its native range of Europe, Scandinavia, and Russia. Adults emerge in early March from the soil around the previous year's yellow toadflax stems and intensively feed on host shoots. Egg laying begins shortly thereafter, and extends over an unusually long period, from mid-March through mid-June. Eggs are deposited in the top or middle of actively growing toadflax stems, causing the stems to swell and form semi-galls. Larvae feed exclusively on this swollen stem tissue, creating chambers where pupation eventually occurs (Figure 59a). Larval feeding results in stunted shoots (Figure 59d). Adults exit host stems in early August via a 'window', where a thin layer of the outer stem tissue is all that remains after larvae chew away the internal gall tissue (Figure 59b). Adult *M. heydenii* (1.6-2.8 mm long, Figure 59c) are smaller than both *M. janthinus* (2.4-3.4 mm) and *M. janthiniformis* (3.2-6.0 mm). *Mecinus heydenii* has been successfully propagated on a range of hybrid toadflax genotypes in North America under quarantine greenhouse conditions, showing promise for release against field hybrids.



Figure 59. *Mecinus heydenii* attacking yellow toadflax a. pupa in stem; b. larval feeding 'windows' (left) through which adults exit (right); c. adult; d. stunted and deformed stems (a-d Ivo Toševski, CABI)

***Mecinus laeviceps* ssp. *laeviceps* Tournier**

Dalmatian toadflax stem-galling weevil

Mecinus laeviceps ssp. *laeviceps* has been collected from Dalmatian toadflax and broomleaf toadflax (*Linaria genistifolia*, closely related to Dalmatian toadflax) in its native range of Macedonia, northern Greece, and Montenegro. In their native range, adult *M. laeviceps* emerge much earlier in the growing season and begin laying eggs up to two months earlier than *M. janthiniformis*. Similar to *M. janthiniformis*, large aggregations of *M. laeviceps* adults feeding on new toadflax shoot growth can result in significant damage to shoot tips and leaves. Eggs (Figure 60a) are typically deposited within, but near the base of growing toadflax shoots between mid-April and the end of May. Egg laying causes swelling of stem tissue, resulting in the formation of reddish-colored semi-galls. The larvae of *M. laeviceps* develop at the base of the toadflax stem while the larvae of *M. janthiniformis* tend to occupy more upper regions of the stem. Following pupation, new adults remain in the pupal chamber feeding on the gall tissue until mid-August (Figure 60b), when they emerge to overwinter in the soil near their host plant. Adult *M. laeviceps* (2.4-3.3 mm long, Figure 58c) are significantly smaller than *M. janthiniformis* (3.2-6.0 mm).

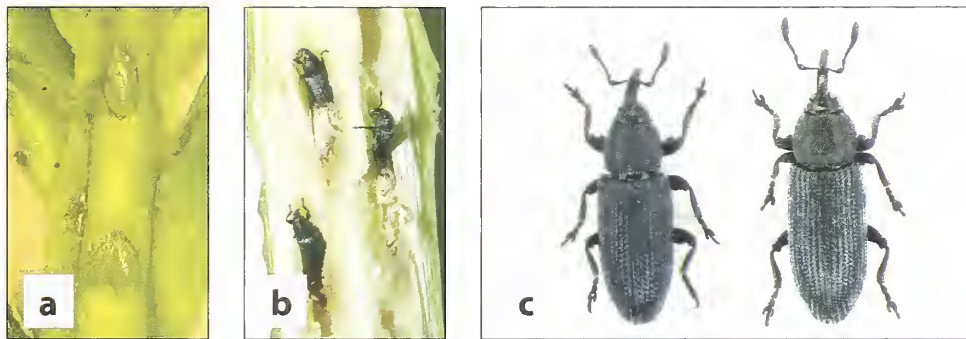

Figure 60. *Mecinus laeviceps* ssp. *laeviceps* a. eggs in a broomleaf toadflax stem; b. adults feeding within a Dalmatian toadflax stem; c. adult male (left) and adult female (right) (a-c Ivo Toševski, CABI)

***Mecinus peterharrisi* Toševski & Caldara sp. n.**

Dalmatian toadflax stem-galling weevil

Mecinus peterharrisi has been collected from both subspecies of Dalmatian toadflax (*Linaria dalmatica* ssp. *dalmatica* and *L. dalmatica* ssp. *macedonica*) in its native range of Macedonia, northern Greece, and Montenegro. The life cycle and other biological attributes of *M. peterharrisi* are similar to *M. laeviceps*; however, *M. peterharrisi* has been collected from higher elevations than *M. laeviceps*, which may make it better adapted than either *M. laeviceps* or *M. janthiniformis* for release at North American Dalmatian toadflax sites experiencing colder climates. In their native range, *M. peterharrisi* emerges earlier in the growing season and begins laying eggs up to two months before *M. janthiniformis*. Similar to *M. janthiniformis* and *M. laeviceps*, large aggregations of *M. peterharrisi* adults feeding on new toadflax shoot growth can result in significant damage to shoot tips and leaves. Eggs are typically deposited near the base of growing toadflax shoots, and oviposition causes stem swelling and the formation of semi-galls on host stems. The larvae of *M. peterharrisi* develop at the base of the toadflax stem while the larvae of *M. janthiniformis* tend to occupy the upper part of the stem. Following pupation, new adults remain in the pupal chamber feeding on the gall tissue until mid-August (Figure 61a), when they emerge to overwinter in the soil near their host plant. Adult *M. peterharrisi* (2.5-3.7 mm long, Figure 61b) are slightly larger than *M. laeviceps* (2.4-3.3 mm long) but significantly smaller than *M. janthiniformis* (3.2-6.0 mm).

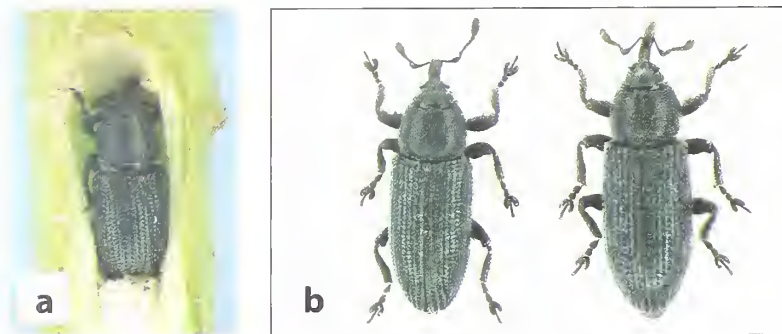

Figure 61. *Mecinus peterharrisi* a. adult in Dalmatian toadflax stem; b. adult male (left) and adult female (right) (a,b Ivo Toševski, CABI)

Rhinusa spp.

(Coleoptera, Curculionidae)

Two new species of *Rhinusa* weevils are currently under consideration as potential toadflax biocontrol agents. Both physically resemble the currently established *R. antirrhini* and *R. linariae*, and are described in greater detail below.

Rhinusa pilosa (Gyllenhal)

Yellow toadflax stem-galling weevil

Rhinusa pilosa has been collected from yellow toadflax throughout its native range of northern Europe. Adults are black, covered in upright hairs, have a distinctive curved profile (Figure 62a), and are up to 4 mm long (excluding the snout) (Figure 62b). In comparison, average *R. antirrhini* and *R. linariae* adults are approximately 3.0 and 2.5 mm long, respectively. The snout gives this weevil a distinctive hook-nosed appearance. In their native range, adult *R. pilosa* adults emerge up to two months earlier in spring compared to the *Rhinusa* species currently established in North America. Eggs are laid in the actively growing tips of yellow toadflax stems, triggering the formation of large, obvious galls (sometimes red-tinged) that can be up to 9 mm wide and 20 mm long (Figure 63a,b). The galls are nearly fully developed by the time eggs hatch, after which the larvae undergo three instars while feeding on the nutrient-rich inner gall tissues before pupating, also within the gall. Galls reduce yellow toadflax height, number of stems, and biomass. The newly emerged adults also remain in the gall for a period of time in early summer-mid fall and feed on remnant gall tissues before chewing their way through the gall wall to exit. Feeding continues on host shoots for a brief period before adults move to the soil or litter where they become inactive, waiting out periods of intense daytime heat, reduced humidity, and food scarcity. These mostly inactive *R. pilosa* adults may occasionally emerge from temporary refuges in the soil or litter to feed on toadflax shoots during cooler, more humid hours in the evening and at night. Once temperatures cool consistently in late autumn, adult *R. pilosa* leave their soil or litter refuges and feed extensively on toadflax re-growth before overwintering in soil or plant litter near senescing host plants. Adaptations for dealing with environmental challenges, such as summer inactivity and overwintering near the ground, make *R. pilosa* especially attractive for release in North America over the wide range of climates where yellow toadflax is invasive.

Rhinusa pilosa was recommended for release in North America by the Technical Advisory Group for Biological Control Agents of Weeds (TAG), but a USA release permit has not yet been granted. Canadian regulatory authorities (CFIA) approved the release of *R. pilosa* in Canada in March

2014. Limited releases of *R. pilosa* were made in Alberta and British Columbia, Canada in both spring 2014 and 2015, after which successful galling of yellow toadflax was confirmed. There also was successful overwintering survival of first generation adults produced from the 2014 releases. Continued monitoring of the new weevil populations is planned to determine population changes, spread, and impact.

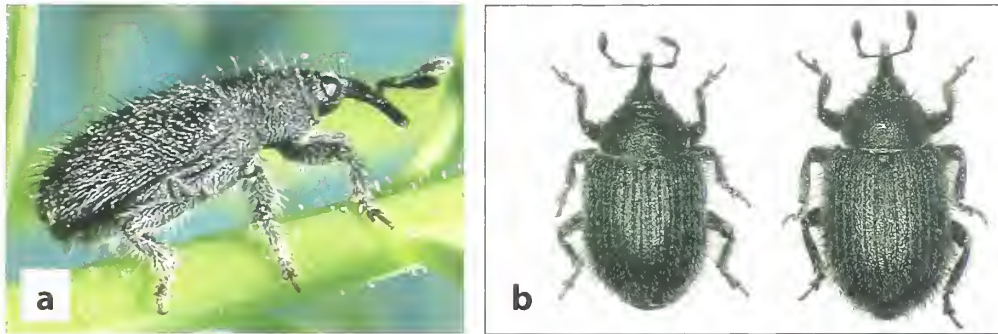

Figure 62. *Rhinusa pilosa* a. adult on yellow toadflax; b. adult male (left) and adult female (right) (a,b (Ivo Toševski, CABI))

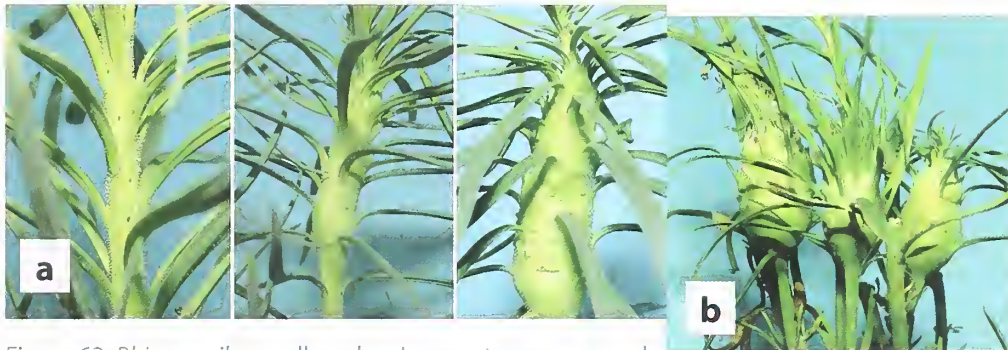

Figure 63. *Rhinusa pilosa* galls a. development over one week (oviposition, 4 days, 7 days); b. mature galls (Ivo Toševski, CABI)

***Rhinusa rara* Toševski & Caldara sp.n.**

Dalmatian toadflax stem-galling weevil

Rhinusa rara is a relatively rare species, but has been collected from Dalmatian and broomleaf toadflax (*Linaria genistifolia*) in its native range of Serbia, Hungary, southern Slovakia, southern Czechia, Austria, and southern Russia. Adults are shiny black, covered in flat-laying hairs, have a distinctly flattened profile, and are up to 3.8 mm long (excluding the snout) (Figure 64a). In comparison, *R. antirrhini* and *R. linariae* adults are approximately 3.0 and 2.5 mm long, respectively. Similar to *R. pilosa*, *R. rara* adults in their native range emerge up to two months earlier in spring compared to *R. antirrhini* and *R. linariae* in North America. Eggs are laid at the base of new toadflax shoots, triggering the formation of galls (Figure 64b,c). Galls formed very early in the season suppress any further shoot growth. When *R. rara* eggs are laid on toadflax stems later in the season, gall development is not triggered. Larvae feed exclusively on gall tissue. New adults exit galls mid-summer after completing all development within the same gall (egg, larva, pupation, adult emergence). Similar to *R. pilosa*, newly emerged *R. rara* adults may continue to feed sporadically on toadflax through autumn, but are frequently inactive in the hot, dry conditions of late summer. Following a brief, but intensive fall feeding period, adult weevils overwinter in the soil or plant litter.

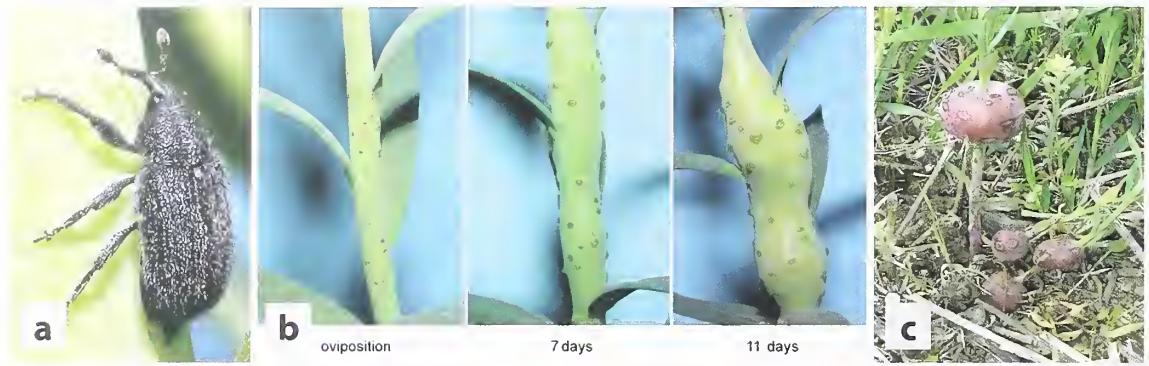

Figure 64. *Rhinusa rara* a. adult; b. gall development over 11 days; c. mature galls in the field (a-c Ivo Toševski, CABI)

CHAPTER 4: ELEMENTS OF A TOADFLAX BIOLOGICAL CONTROL PROGRAM

Before You Begin

The results of using biological control to treat toadflaxes vary from site to site for a variety of reasons. Land managers should develop treatment programs that complement land use activities and management objectives unique to the area. This is accomplished by first understanding the scope of the toadflax problem, defining overall goals for the toadflax management program, and understanding the control methods available for accomplishing the goals.

Determining the Scope of the Problem

Your first step should be to develop a distribution map of toadflaxes at a scale that will allow you to address the problem in a manner consistent with your overall land management objectives and available weed management resources. The most appropriate scale may encompass a large landscape with a variety of site characteristics and land uses managed by many different land owners/managers—all of whom contribute to mapping efforts (Figure 65a). In large landscapes with significant toadflax infestations and limited mapping resources, aerial mapping of large patches of toadflaxes may be sufficient to identify priority areas for additional survey and weed management activities. In other management areas with small, discrete toadflax infestations, or where an infestation's characteristics affect your ability to meet management objectives, your weed management strategy might have to include more extensive mapping and analysis of the scope of the infestations (e.g. size, density, cover, or location in relation to roads and waterways over time) (Figure 65b). In many cases, it may prove useful to check for existing toadflax distribution data before collecting your own. Several different agencies and organizations maintain weed distribution databases,

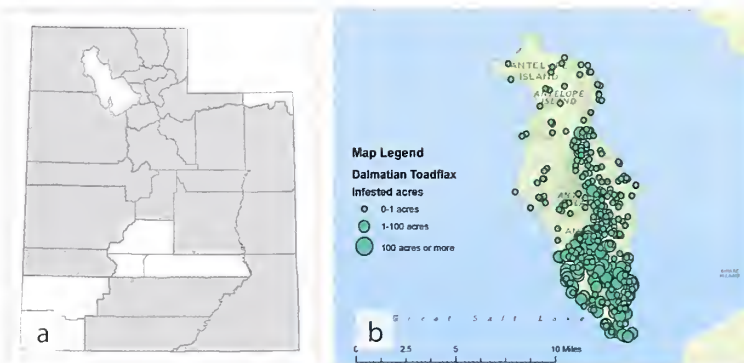

including state agricultural departments, provincial ministries (e.g. British Columbia IAPP Application), invasive plant/species councils, USDA PLANTS database, EDDMapS, and many others. EDDMapS can be particularly useful for land managers interested in creating toadflax

Figure 65. Dalmatian toadflax data for a. counties with Dalmatian toadflax in the state of Utah (EDDMapS); b. infestations on Antelope Island in the Great Salt Lake, Utah (Becca VanKampen, MIA Consulting, EDDMapS)

distribution maps for their area. By visiting www.eddmaps.org and creating a free account, users can view existing distribution maps for toadflaxes or other weeds at the state, county, or point level. By selecting the GIS view option, users can view toadflax data on various backgrounds and zoomed into different scales, add hand drawn labels, boundaries, points and other shapes to the map, perform measurements such as perimeter estimates or distance between points, add new toadflax data from user shapefiles, edit the management status of various infestations, and print finished maps (see page 90 for more information on EDDMapS).

Defining Goals and Objectives

Goals broadly define the “what” or desired outcome of management; objectives define the “how” or specific activities through which desired outcomes can be achieved. To be effective, objectives must be SMART: specific, measurable, achievable, realistic, and timely. Defining your weed management goals and objectives is the crucial first step in developing a successful biological control program. By defining what you want to achieve, you will be able to determine if, when, and where you should use biological control.

As precisely as possible, you must define what will constitute a successful toadflax management program. For example, the objective of “. . . a noticeable reduction in toadflax density over the next ten years . . .” might be achievable, but it uses a subjective measurement of success that is open to observer bias. Alternatively, the objective of “. . . a 50 percent reduction in toadflax stems over the next three years . . .” is objectively measurable (and therefore SMART). If your goal is to reduce the abundance of toadflaxes, then biological control might be an appropriate weed management tool; however, by itself biological control will not completely and permanently remove toadflaxes from the landscape. If your goal is to eradicate toadflaxes, then you should plan to employ other weed control techniques instead of, or in addition to, biological control (see Chapter 5 for more details).

Understanding Toadflax Management Options

Once you determine the scope of your toadflax infestations and define your overall program goal and objectives, review the weed control methods available (biological control, physical treatments, cultural practices, and herbicides), and determine the conditions (when, where, if, etc.) under which it might be appropriate to use each method or combination of methods (see Chapter 5). Consult commercial, agency, or university biological control experts, cooperative weed management area partners, or county weed coordinator/supervisors to learn about other toadflax management activities (herbicide use, grazing, etc.) underway or planned for your area, and the level and persistence of control that might be achieved by each.

Identify the resources that will be available for weed management activities, and determine if they will be consistently available until you meet your weed management program objectives. If resources are not currently available, or will not be available consistently, identify what will happen at the treatment site if planned management activities are not implemented or are not completed. This information will help you determine the best management activities to use as you initiate and continue your integrated toadflax management program.

With a map of toadflax infestations in your management area, an understanding of your land management goals, well defined weed management objectives, and a list of the weed control

methods available with the level of control you can realistically expect from each, you can identify sites where biological control would be a good fit, alone or in combination with other control methods.

Developing, Implementing, and Managing a Toadflax Biological Control Program

When biological control is deemed suitable for treating your toadflax infestations, there are several important factors to consider. These include selecting appropriate release sites, obtaining and releasing biocontrol agents, and monitoring the success of the program. Familiarity with all aspects of a biocontrol program before beginning will greatly facilitate its implementation and increase its chances of success. These items are discussed in their own sections below. If problems are encountered following the initiation of a toadflax biological control program, refer to the troubleshooting guide in Appendix I for potential solutions.

Selecting Biological Control Agent Release Sites

Establish goals for your release site

Consider your overall management goals for a given site when you evaluate its suitability for the release of biological control agents. Suitability factors will differ depending on whether the release is to be a:

1. general release, where biological control agents are simply released for toadflax management,
2. field insectary (nursery) release, used primarily to mass produce biological control agents for redistribution to other sites, or
3. research release, used to investigate biological control agent biology and/or the agent's impact on the target weed and nontarget plant community.

A site chosen to serve one of the roles listed above may also serve additional functions over time (e.g., biological control agents might eventually be collected for redistribution from a research or general release).

Determine site characteristics

For practical purposes, no toadflax infestation is too large for biocontrol releases; however, it might not be large enough (Figure 66a). Very small, isolated patches of toadflaxes may not be adequate for biological control agent populations to build up and persist and are often better off treated with other weed control methods, such as herbicides or physical control. Toadflax infestations of at least 4 acres (1.6 hectares) are typically the minimum size recommended for biological control releases, but larger infestations are more desirable (Figure 66b), especially if the land manager hopes to someday use the release site as a field insectary. Biocontrol agents disperse more easily in contiguous toadflax infestations than in infestations with only a few scattered plants and distant patches. If your biological control program goals involve evaluating the program's efficacy, establish permanent monitoring sites before you release any biocontrol agents. Monitoring sites require regular inspections, so consider the site's ease of accessibility, terrain, and slope.



Figure 66. Toadflax infestations a. too small for biological control (Hal Pearce, USDA FS); b. appropriate size for biological control (Sharlene E. Sing, USDA FS RMRS)

Note land use and disturbance factors

Release sites should experience little to no regular disturbance. Abandoned fields/pastures and natural areas are good choices for biological control agent releases. Sites where insecticides are used should not be utilized for biocontrol agent releases. Such sites include those near wetlands that are subject to mosquito abatement, rangelands that are subjected to grasshopper control, or near agricultural fields or orchards where pesticide applications occur regularly. Roadside infestations along dirt or gravel roads with heavy traffic should also be avoided; extensive dust makes toadflax plants less attractive to biocontrol agents and silica may kill larvae. Do not use sites where significant land use changes will take place, such as road construction, cultivation, building construction, and mineral or petroleum extraction. If supply of biocontrol agents is limited, prioritize release sites that are not regularly burned or treated with herbicides.

Survey for presence of biological control agents

Always examine your prospective release sites to determine if toadflax biological control agents are already present. If an agent you are planning to release is already established at a site, you can still release it at that site to augment the existing population. If populations already appear to be abundant, then it may be better to make the release at another site. Re-evaluate planned releases if another species of biological control agent is already present; e.g. competition between *Brachypteroles pulicarius* and *Rhinusa antirrhini*/*R. neta* prevents these species from having an additive impact in many locations. Consider releasing a biocontrol agent known to be more effective, such as the toadflax stem miners *M. janthinus* or *M. janthiniformis*, on sites where less effective, widely distributed agents as *B. pulicarius*, *Rhinusa antirrhini* and *Calophasia humila* are already established.

Record ownership and access

If you release biological control agents on private land, it is a good idea to select sites on land likely to have long-standing, stable ownership and management. Stable ownership will help you establish long-term agreements with a landowner, permitting access to the sites to sample or harvest biological control agents and collect insect and vegetation data for the duration of the project. This is particularly important if you are establishing a field insectary site, because five years or more of access may be required to complete insect harvesting or data collection. General releases of biological control agents to control toadflax populations require less-frequent and short-term access; you may need to visit such

a site only once or twice after the initial release. When releasing biocontrol agents on private land, it may be a good idea to obtain the following:

- written permission from the landowner allowing use of the area as a release site,
- written agreement with the landowner allowing access to the site for monitoring and collection for a period of at least six years (three years for establishment and buildup and three years for collection),
- permission to put a permanent marker at the site, and
- written agreement with the landowner that land management practices at the release site will not interfere with biological control agent activity

The above list can also be helpful for releases made on public land where the goal is to establish an insectary. In particular, an agreement should be reached that land management practices will not interfere with biological control agent activity (e.g. spraying or physically destroying the weed infestation). It is often useful to visit the landowner or land manager at the release site annually to ensure they are reminded of the biological control endeavors and agreement.

You may wish to restrict access to release locations, especially research sites and insectaries, and allow only authorized project partners to visit the sites and collect insects. The simplest approach is to select locations that are not easily visible to or accessible by the general public (Figure 67a). To be practical, most if not all of your sites will be readily accessible, so in order to restrict access you should formalize arrangements with the landowner or manager. This will require you to post no-trespassing signs, install locks on gates, etc. (Figure 67b).

Another consideration is physical access to a release site. You will need to drive to or near the release locations, so determine if travel on access roads might be interrupted by periodic flooding or inclement weather. You might have to accommodate occasional road closures by private landowners and public land managers for other reasons, such as wildlife protection.

Choosing the Appropriate Biological Control Agents for Release

You should consider several factors when deciding which biological control agent to release at a site, including agent efficacy, availability, and site preferences (Table 7).



Figure 67. Methods for discouraging biocontrol agent release site access a. being very difficult to approach (Jesse Young, USDA FS RMRS); b. posting “no disturbance” sign (Alan Martinson, Latah County Weed Control & Paul Brusven, Nez Perce BioControl Center)

Table 7. Summary of general characteristics and site preferences of toadflax biological control agents established in North America.

Agent Characteristics			Site characteristics		
SPECIES	PART ATTACKED	EFFICACY	AVAILABILITY	FAVORABLE CONDITIONS	UNFAVORABLE CONDITIONS
<i>Brachypterosus pullicarius</i> Toadflax flower-feeding beetle	Flowers	Prefers yellow toadflax, on which it delays flowering and reduces seed production. Though abundant, its overall impact is minimal.	Widespread in the USA and CAN, but because it has low impact, it is a low priority for redistribution.	Well adapted to a variety of conditions throughout the majority of toadflax infestations in North America.	No specific unfavorable conditions determined to date.
<i>Calophasia lunula</i> Toadflax defoliating moth	Leaves	Widespread but usually in low densities on yellow and Dalmatian toadflax in the USA and CAN. High densities cause heavy defoliation, but mature plants usually recover.	Limited throughout the North American Northwest and in ON, NB, and NS. Because it has low impact, and may attack desirable snapdragons, it is a low priority for redistribution.	Warm, dry sites with coarse-textured soils. Frequently found in sparse toadflax infestations.	Cold climates, northern latitudes, high elevations, dense toadflax infestations.
<i>Mecinus janthiniiformis</i> Dalmatian toadflax stem-mining weevil	Stems, leaves, shoot tips	Successful in warmer inter-mountain climates. Mining and adult feeding significantly decrease Dalmatian toadflax populations in the USA and CAN (Southern Interior, British Columbia). Like to travel uphill	Common through parts of the North American Northwest.	Well adapted to a variety of conditions; winter temperatures lower than -18.5° F (-28° C) cause temporary population reductions.	Cold climates and regions with fluctuating spring temperatures (e.g. eastern slope of Rocky Mountains) less ideal, though populations can rebound from killing winter temperatures.
<i>Mecinus janthinus</i> Yellow toadflax stem-mining weevil	Stems, leaves, shoot tips	Populations are still limited. Mining and adult feeding decrease yellow toadflax populations locally in the USA and still under study in CAN. Like to travel uphill.	Limited distribution on sites throughout the North American Northwest and in Nova Scotia. Populations are small but increasing; adults readily disperse to colonize new plants/patches.	Mild, low-elevation sites, though successful populations have been observed above 7,000 feet (2,180 m).	Still being determined for North America, though likely to include cold climates.

Table 7 continued. Summary of general characteristics and site preferences of toadflax biological control agents established in North America

Agent Characteristics		Site characteristics			
SPECIES	PART ATTACKED	EFFICACY	AVAILABILITY	FAVORABLE CONDITIONS	UNFAVORABLE CONDITIONS
<i>Rhinusa antirrhini</i> Toadflax seed-galling weevil	Seeds	Prefers yellow toadflax, on which it reduces seed production. Despite its high abundance, overall impact is limited.	Limited on Dalmatian toadflax in the Northwest and in Ontario. Widespread on yellow toadflax in northern USA and southern CAN. Because it has low impact, it is a low priority for redistribution.	Well adapted to a variety of conditions throughout the majority of toadflax infestations in North America.	No specific unfavorable conditions determined to date.
<i>Rhinusa linariae</i> Toadflax root-galling weevil	Roots	Prefers yellow toadflax on which it reduces plant nutrient reserves. Established in BC only, its populations are too low for significant impact.	Populations are very limited and established only in BC CAN to date. Insufficient for redistribution.	Largely unknown because of its low establishment. In Europe, it does best at low elevation sites.	Unknown, possibly high elevation sites.
<i>Rhinusa neta</i> Toadflax seed-feeding weevil	Seeds	Prefers yellow toadflax, on which it reduces seed production. Despite its high abundance, overall impact is limited.	Limited on yellow toadflax and even more so on Dalmatian toadflax in the USA and CAN. Not approved for redistribution in the USA.	Unknown	Unknown

Biocontrol agent efficacy

Efficacy refers to the ability of the biological control agent to directly or indirectly reduce the population of the target weed below acceptable damage thresholds or cause weed mortality resulting in control. It is preferable to release the most effective biocontrol species rather than releasing all available biocontrol species against the target weed. Consult with local weed biological control experts, neighboring land managers, and landowners to identify the agent(s) that appear(s) more effective given local site characteristics and management scenarios.

Biocontrol agent availability

The toadflax root moths, *Eteobalea* spp., are not known to have established in North America. All seven of the remaining toadflax biocontrol agents described in this manual are established, though their availability varies greatly between species and sites. *Mecinus janthiniformis* is currently the most effective Dalmatian toadflax biocontrol agent, and is readily available for collection throughout the northwestern USA and the Southern Interior of British Columbia. *Mecinus janthinus* prefers yellow toadflax, and though it is currently less widespread than *M. janthiniformis*, populations of *M. janthinus* are increasing in parts of northwestern North America. The toadflax defoliating moth, *Calophasia lunula*, is established on both Dalmatian and yellow toadflax at multiple locations in the USA and Canada, though its abundance and impact are typically limited. The toadflax root-galling weevil, *Rhinusa linariae*, is established only in British Columbia, and populations are limited. The flower- and seed-feeding beetles *Brachyterolus pulicarius* and *R. antirrhini* are widespread on their hosts in North America; however, their low impact and wide distribution make them low priorities for redistribution. The seed-feeding beetle *R. neta* is more limited in its distribution throughout North America; however, it has low impact and is also **not approved for redistribution in the USA**.

Federal and state/provincial departments and commercial biological control suppliers may be able to assist you in acquiring agents not yet available but permitted for use in your area (see Obtaining and Releasing Toadflax Biological Control Agents, below). In the USA, state departments of agriculture, county weed managers, extension agents, or federal and university weed biological control specialists should be able to recommend in-state sources.

Release site characteristics

General physical site and biological preferences for each agent have been developed from anecdotal observations and experimental data. These are listed in Table 7 to help land managers ensure that insects are released in sites with suitable conditions.

Obtaining and Releasing Toadflax Biological Control Agents

You can obtain toadflax biological control agents by collecting or rearing them yourself, having someone collect them for you, or by purchasing them from a commercial supplier. This section provides information on collecting and purchasing toadflax biocontrol agents, with emphasis on *Mecinus janthinus* and *M. janthiniformis*. The toadflax root-galling weevil, *Rhinusa linariae*, is currently less available in the field. *Brachyterolus pulicarius*, *Calophasia lunula*, and *R. antirrhini* are already widespread and have limited impact, so are not highly recommended for redistribution. *R. neta* is not approved for redistribution in the USA.

Factors to consider when looking for sources of biological control agents

You do not need to take a “lottery approach” and release all available biological control agents at a site in the hopes that one of them will work. In fact, some biological control agents will not be available even if you want them (e.g. *Eteobalea* spp.), and some have been shown to have little or no effectiveness in certain areas (e.g. *Brachypterolus pulicarius* and *Rhinus antirrhini*). The best strategy is to release the best agent! Ask the county, state, provincial, or federal biological control experts in your area for recommendations of agents for your particular project.

If available, biological control agents from local sources are best. Using local sources increases the likelihood that biocontrol agents are adapted to the climate and site conditions present and are available at appropriate times for release at your target infestation. Using locally sourced agents also reduces the possibility of accidentally introducing biocontrol agent pathogens or natural enemies to your area. Local sources may include neighboring properties or other locations in your and adjacent counties/districts. Remember that in the USA, interstate transport of biological control agents requires a USDA-APHIS-PPQ permit (see Regulations Pertaining to the Transfer of Toadflaxes Biological Control Agents, page 88). Get your permits early to avoid delays.

Some USA states, counties, and universities have “field days” at productive insectary sites (Figure 68a,b). On these days, land managers and landowners are invited to collect or receive freshly collected toadflax biological control agents for quick release at other sites. These sessions are an easy and often inexpensive way for you to acquire biological control agents. They are good educational opportunities as well, because you can often see first-hand the impacts of various biocontrol agents on toadflax plant communities.

Typically, field days are conducted at several sites in a state and on several dates. Although designed for intrastate collection and redistribution, out-of-state participants may be welcome to participate (remember that USDA permits are required for interstate movement and release of biological control agents). Contact county weed supervisors, university weed or biological control specialists, or federal weed managers for information about field days in your region.

Collecting Toadflax Biological Control Agents

Planning and timing of collection is critical. For all species, it is usually most efficient to scout the potential collection site well in advance to ensure your desired species is present at suitable densities. The species of biological control agent and weather characteristics at your



Figure 68. Toadflax field days a. yellow toadflax (Sharlene E. Sing, USDA FS RMRS); b. Dalmatian toadflax (Melissa Griffiths, Madison Valley Ranchlands)

collection and release site will determine the best time in the season to collect. Ensure that all necessary collection supplies are on hand. Also, accurate identification of the biological control agents is essential. General guidelines for collecting toadflax biological control agents are listed below and in Table 8.

For all species, collect only on a day with good weather. Do not collect in the rain; insects will hide and become difficult to find in rainy weather, excess moisture causes health problems, and biocontrol agents may drown in wet collection containers. As a general rule of thumb, biocontrol agent populations are large enough to permit redistribution collections if the number of insects recommended for an initial release can be harvested in a fairly short period of time (less than an hour). For example, if 200 adult weevils are recommended for a stem-mining weevil release, you should be able to easily collect several hundred adult weevils in about 30 minutes or less from a collectible population. If it takes several hours to collect 200 weevils, then the population is not large enough to support redistribution collections. There is generally no danger of over-collecting at an established site, provided 1) collections stop when it becomes difficult to find insects; and 2) collections are made once or, at most, only a few times during a season.

Collection methods

Tray sampling, hand picking, aspirating, sweep netting, and transferring biocontrol agent-infested plant material are commonly used methods for collecting toadflax biocontrol agents. The most appropriate method will depend on the physical characteristics of the insect, the density of the insect population, time of year, time available for collecting, and available personnel. Regardless of the method used, it is most effective to collect biocontrol agents and release them on the same host species (i.e. if collecting from Dalmatian toadflax, release the collected individuals on Dalmatian toadflax).

Tray sampling: The tray sampling method is the most efficient way to collect adult beetles (*Brachyterolus pulicarius*, *Mecinus* spp., and *Rhinusa* spp.), especially when their populations are high. Using your hand or a short stick, gently tap the plant, knocking the beetles from the plant into a plastic tray or tub (Figure 69a,b). Choose a tub or tray appropriate for the size of the plants/position of agents on the plants: for example, if you need to capture *M. janthiniformis* adults sheltering in leaf axils all along the length of a tall Dalmatian toadflax stem, a larger sized tub or tray will be required than for collecting *M. janthinus* from stunted yellow toadflax plants. Avoid disturbing the toadflax before tapping because this will often cause most beetles to drop to the ground. Cover or frequently shake the tray or tub to prevent biocontrol agents from escaping, and sort the agents prior to shipping (see below).

Hand picking: Hand picking is required for collecting easily damaged insects such as the larvae of *Calophasia lunula*. Flexible forceps, which bend around larvae without injuring them as traditional tweezers would, are typically used to pluck agents from toadflaxes. In some cases it may be easier and more productive to break off a section of host plant where insects are aggregated, rather than collect them on an individual basis. Small paintbrushes (e.g., those used for art projects) are also useful for delicate hand picking jobs with small larvae or eggs.

Aspirating: An aspirator is a device used to suck insects from a surface into a collection vial. Aspirators can be used to collect insects out of a sweep net or off a sorting tray (both described below), out of a sorting cage, or to collect adults of *B. pulicarius*, *Mecinus* spp.,

Table 8. Recommended timetable and methods for collecting toadflax biological control agents in North America. Methods are listed in the order of ease of collection.

BIOCONTROL AGENT	BIOCONTROL AGENT STAGE	TOADFLAX PLANT STAGE	TIMING	METHOD	NOTES
<i>Braconypterus pulicarius</i> Toadflax flower-feeding beetle	Adults	Stems bolting to early flowering	May to June	Aspirate or hand-pick adults from inside flowers, or collect using a sweep net or tray.	Though approved for redistribution, it is already widespread with low impact, so is not a high priority for redistribution.
<i>Calophasia lunula</i> Toadflax defoliating moth	Larvae (caterpillars)	Stems early flowering to mature	Mid-June through September	Hand pick larvae from plants	Limited impact makes low priority for redistribution. Reports of nontarget attack; redistribute with caution.
<i>Eteobalea intermediella</i> Dalmatian toadflax root-boring moth <i>Eteobalea serratella</i> Yellow toadflax root-boring moth	N/A	N/A	N/A	N/A	Despite multiple releases, these species have not been confirmed as established in North America.
<i>Mecinus janthiniiformis</i> Dalmatian toadflax stem-mining weevil	Adults	Stems bolting to flowering	Adults: April to late June; Infested Stems: fall-early spring	Tray sampling, sweep netting, or moving <i>M. janthiniiformis</i> -infested stems to uncolonized weed patches	Already widespread, but should be redistributed to Dalmatian toadflax populations where not currently established.
<i>Mecinus janthinus</i> Yellow toadflax stem-mining weevil	Adults	Stems bolting to flowering	Adults: late March to mid-June depending on climatic region; Infested stems: fall-early spring	Tray sampling, sweep netting, or moving <i>M. janthinus</i> -infested stems to uncolonized weed patches	Not widespread and should be redistributed to yellow toadflax populations where not currently established.
<i>Rhinusa antirrhini</i> Toadflax seed-galling weevil	Adults	Stems bolting to flowering	May to mid-June	Tray sampling, sweep netting, or aspirating adults from flowers	Though approved for redistribution, it is already widespread with low impact, so is not a high priority for redistribution.
<i>Rhinusa linariae</i> Toadflax root-galling weevil	Adults	Stems bolting to flowering	May	Tray sampling or sweep netting	Failure to determine establishment at many release sites and low impact of established populations make this a low priority for redistribution.
<i>Rhinusa neta</i> Toadflax seed-feeding weevil	N/A	N/A	N/A	N/A	This species is not approved for redistribution within the USA.



Figure 69. Tray sampling to collect toadflax biocontrol agents a. (Sharlene Sing, USDA FS RMRS); b. (Carol Bell Randall, USDA FS)

and *Rhinusa* spp. directly from toadflax plants. A variety of aspirators can be purchased from entomological, forestry, and biological supply companies, or you can construct one yourself. Aspirators are powered by mouth suction, manually by using an aspirating bulb (Figure 70a), or mechanically using a modified hand vacuum (Figure 70b). Inline filters are commercially available to prevent unintentional inhalation or swallowing of debris or insects during mouth aspiration. At the very least, mouth aspirators should be equipped with fine-mesh screening on the vial end of the tubing held in the mouth so that insects and small particles are not inhaled (Figure 70a). In some cases, biocontrol agents might be abundant enough to collect with a specialized insect vacuum (Figure 70c).

Sweep netting: A sweep net consists of a conical canvas or muslin bag held open on one end by a sturdy wire hoop 10-15 inches in diameter (25-38 cm) attached to a handle 3 feet long (0.9 m, Figure 71a). Insects are ‘swept’ off toadflax plants and accumulate in the closed (narrow) end of the conical net. Sweep nets can be purchased from entomological, forestry, and biological supply companies, or you can construct them yourself. Heavy-duty nets and rigorous sweeping are required to dislodge biocontrol agents from toadflaxes. However, many beetles will fail to fall into the net. Sweeping also breaks off many shoots, killing any *Mecinus* eggs and larvae contained inside. Sweeping is not a recommended method for collecting toadflax agents because it can significantly reduce the number of *Mecinus* offspring emerging on swept sites in following year(s).

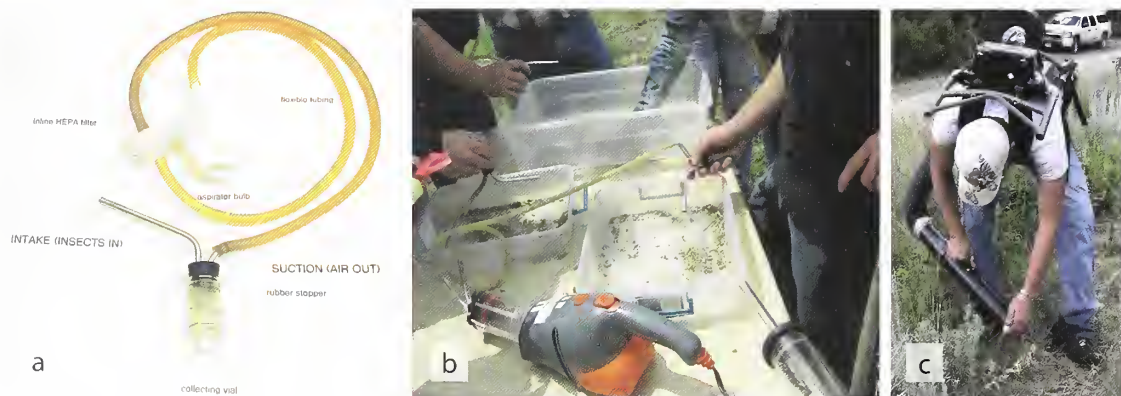

Figure 70. Aspirators for collecting toadflax biocontrol agents a. mouth aspirator with inline HEPA filter, bulb, and collection vial indicating release density fill levels; b. modified hand vacuum aspirator (Carol Bell Randall, USDA FS); c. motorized backpack aspirator (a,c Sharlene E. Sing, USDA FS RMRS)

A sweep is made by swinging the net through the upper plant canopy and collecting insects off the foliage. It is best to use no more than 25 sweeps before removing the biocontrol agents from the net. Removing insects at regular intervals reduces the harm that could result from knocking biocontrol agents around with debris, and reduces opportunities for predatory insects and spiders swept up with the biocontrol agents to find and devour the biocontrol agents. It is often helpful to dump the contents of the sweep net into a shallow tray or basin to facilitate sorting by aspirating biocontrol agents from debris and other insects in the net.

Transferring agent-infested plant material: This method is applicable for the *Mecinus* weevils. Because adults overwinter within toadflax stems, infested stems can be cut, bundled (Figure 71b), and moved to new sites where the weevils are not yet established. Stems can be collected from late fall through early spring. However, all collected stems must then be retained under consistently cold, moist conditions (9°C or 48°F at ~60% humidity) to keep agents alive and discourage them from leaving the stems, until host plants begin growing on release sites the following spring. If you use this method, always remove roots, seed capsules and loose seeds to eliminate the spread of toadflax propagules (seeds and root buds) to new sites as this can introduce new toadflax genetic material.

Sorting: Tray sampling, sweep netting, and vacuum sampling are not selective collection methods, so other insects and spiders are usually collected along with the biocontrol agents. Sorting separates the biocontrol agents from unwanted insects, other organisms and debris, such as weed seeds, collected along with the biocontrol agents. The easiest way to sort is to empty the contents of the net or tray into a plastic tub and aspirate the toadflax biocontrol agents out of the debris. If the collected material is first chilled in a cooler, the insects will move more slowly and will be easier to catch and sort. Use an aspirator (described above) to sort the biocontrol agents (Figure 72a,b). To speed up the sorting process, count out a set number of agents 2-5 times (for example, 200 or 500 adult *Mecinus* spp. weevils) into separate collecting vials. Tap the bottom of vial to knock down all the weevils, then mark the fill level on the vial. Use the average fill level based on those 2-5 collection vials to collect approximate release-size densities of agents without needing to count out each individual insect. Remember that *M. janthinus* adults are smaller than *M. janthiniformis* adults, so different release density fill levels need to be used for these two species.



Figure 71. Toadflax biocontrol agent collection methods a. sweep net (Laura Parsons, University of Idaho, bugwood.org); b. 50-stem bundles of *Mecinus*-infested yellow toadflax stems (top) and Dalmatian toadflax stems (bottom)(after removing all roots, seed capsules, and loose seeds); c. the same 50-stem bundles of Dalmatian toadflax stems (left) and yellow toadflax stems (right) shown in 71b, with stems fanned out on one end to facilitate the dispersal of emerging adult *Mecinus* spp. (b,c Sharlene E. Sing, USDA FS RMRS)

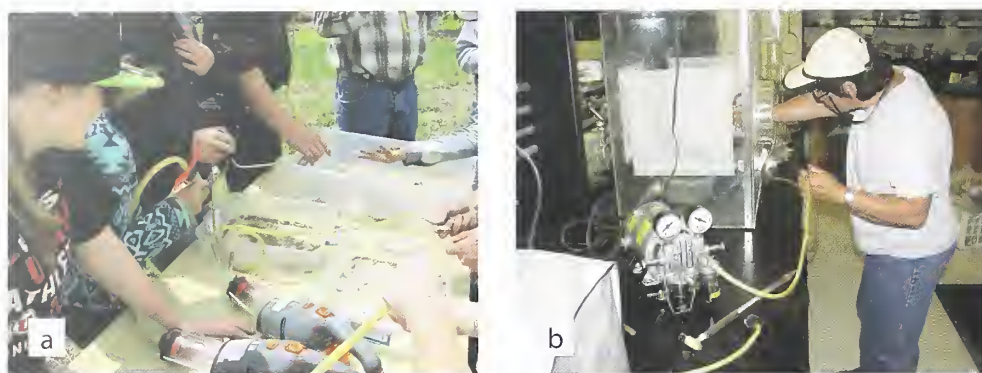

Figure 72. Sorting toadflax biocontrol agent collections a. in the field with mechanical aspirators and trays (Carol Bell Randall, USDA FS); b. in a cage with a mechanical aspirator (Sharlene E. Sing, USDA FS RMRS)

Collection methods by species

Toadflax flower-feeding beetle: (*Brachyterolus pulicarius*): Collect adult beetles. Adults are easily collected by aspirating individual beetles from inside the flowers and from stem tips. Adults can also be collected using the tray sampling method if their populations are large. Sweeping the tops of plants is a slower, more destructive, and less selective method for collecting adults. Depending on location, the best time to collect adult beetles is May to June, when they have emerged from overwintering sites and are actively feeding, aggregating near the tops of the plants, and mating. The best time of day to collect adults is mid- to late morning, when they are active but still moving slowly. Adult beetles are very sensitive to heat; hot afternoons cause them to seek shaded niches. This beetle is already widespread throughout North America, but has a low overall impact on toadflax populations. Consequently, it is not a high priority for redistribution.

Toadflax defoliating moth: (*Calophasia lumula*): When collecting the defoliating moth, it is better to collect the larvae. Although care still needs to be taken when collecting larvae, the adult moths are substantially more fragile and difficult to find. Gently pick larvae off of plants by hand or with the aid of flexible forceps that were designed to prevent the crushing of soft-bodied larvae, carefully dislodge them into shallow plastic tubs, or just break off and collect toadflax shoots where multiple early-instar larvae are feeding. Larger caterpillars may regurgitate a green liquid when handled; this is a normal defensive response and does not indicate the caterpillar is injured. Larvae will frequently drop from the plant when approached or touched. Sweeping is not advised because it will injure the larvae. Young larvae will be found on young foliage or flowers; older larvae are found on larger leaves or stems. It is important not to place too many larvae (less than 50) in a container as overcrowding may result in cannibalism. Ensure that collecting bins and shipping containers are well provisioned with healthy toadflax leaves and kept cool because larvae are heat sensitive. Caterpillars can be collected from mid-June through September. **Because of concerns about the host specificity of this insect and its tendency to disperse widely from its point of release, we do not recommend collecting the defoliating moth for redistribution, particularly in the USA.**

Toadflax stem-mining weevils (*Mecinus janthinus*/*M. janthiniformis*): Collect adult beetles. Adults are collected by tapping plants over tubs or trays to dislodge the insects, or by sweeping

the tops of toadflax plants. Tray sampling is preferable to sweeping because sweeping can break off shoots with eggs and larvae developing inside, which reduces the number of adults that can emerge the following spring. Choose a tub or tray appropriate for the size of the plants/position of agents on the plants: for example, if you need to capture abundant *Mecinus janthiniformis* adults sheltering in leaf axils all along the length of a tall Dalmatian toadflax stem, a larger sized tub or tray will be required than for collecting *M. janthinus* from stunted yellow toadflax plants. At peak densities, several thousand *M. janthiniformis* adults can be collected in 2-3 hours. Depending on location, the collecting period is generally from late April through June when adults have emerged from overwintering in last year's stems and are actively feeding and mating on the top portions of new toadflax shoots. *Mecinus janthinus* adults can be collected slightly earlier than *M. janthiniformis* adults.

Because adults overwinter within attacked toadflax stems, infested plants can also be cut, bundled, and moved to new sites where the weevils are not yet established. When releasing by transferring toadflax stems infested with *Mecinus* spp., begin by confirming that agent population densities are high by splitting 10-20 stems randomly selected throughout the collection site. If most stems evaluated contain more than 2 adults, carefully harvest entire stems, keeping them as intact as possible by cutting them off at soil level with gardening pruners. Gently remove seed capsules, brush away any loose seeds and soil, and cut off all root material at the collecting site. Assemble bundles of 20-50 stems that are tied with kitchen twine at each end of the bundles (Figure 71b). Transport bundles loosely stacked in plastic bins fitted with lids. Do not allow stems to become warm or dried out during transportation or storage. Stems can be collected from fall through early spring but must be stored under consistently cold, moist conditions (9°C or 48°F with ~60% humidity) to keep agents alive and discourage them from leaving the stems prematurely. Once host plants in the field begin spring growth, release *Mecinus* by cutting the binding on one end of the stem bundle so that the stems can be fanned out and the bundle can be placed upright within a dense stand of uncolonized host plants. Failing to cut binding from one end of the bundle can prevent adult *Mecinus* in interior stems from successfully exiting the bundle. Precautions must be taken to eliminate the spread of toadflax propagules (seeds and root buds) to new sites as this can introduce new toadflax genetic material. Though this method requires a large effort, it can be useful for transferring *M. janthinus* to uncolonized yellow toadflax infestations due to the relatively limited establishment of *M. janthinus* in North America. Stem transfers can also be useful for both yellow and Dalmatian toadflax infestations that occur at high elevations where toadflax plant development is often delayed. Adult *Mecinus* spp. emergence on low elevation toadflax can occur too early to be used for making biocontrol releases on high elevation sites. The stem transfer method is therefore also a useful alternative for making later season releases on high elevation toadflax infestations.

Toadflax seed-galling weevil (*Rhinusa antirrhini*): Collect adult beetles. Adults are collected by tapping plants over tubs or trays to dislodge the insects, or by sweeping the tops of toadflax plants. Aspirating individual adults or mating pairs from plants is possible but slow and laborious. Collect the seed-galling weevils during the heat of the day. The optimal time to collect is the period between the appearance of flower buds and the onset of flowering. Mating pairs aggregate at the top of plants, and are easily seen. Depending on location, the collecting period is generally from May to mid-July when adults are actively feeding and mating on the top portions of plants. More beetles are collected from yellow toadflax than from Dalmatian toadflax. This beetle is already widespread throughout North America, but has a low overall impact on toadflax populations.

Consequently, it is not a high priority for redistribution. A related species, the toadflax seed-feeding weevil *Rhinusa neta*, is not approved for redistribution in the USA.

Toadflax root-galling weevil (*Rhinusa linariae*): Only a few known populations are believed to be established in Canada, so this weevil is largely unavailable at this time. When collections are deemed possible, this should only be done under the guidance of the appropriate Canadian authority. Generally adult beetles are collected throughout May when they are actively feeding and mating on the top portions of plants but before females move to the bases of the plants to oviposit. Tapping weevils into collection trays or tubs is the recommended collection method.

Release Containers for Toadflax Biological Control Agents

The manner in which biological control agents are handled during transportation to the release site will affect whether they will survive and multiply at the new site. To reduce mortality or injury, it is best to release biocontrol agents the same day they are collected.

Following collection, biocontrol agents need to be transferred to release containers intended to protect them (and to prevent insects from escaping en route). Release containers should be rigid enough to resist crushing but also ventilated to provide adequate airflow and reduce condensation. Un-waxed paperboard cartons are ideal; they are rigid, permeable to air and water vapor, and are available in many sizes. As an alternative, you can use release containers made of either light-colored lined or waxed paper (e.g., ice cream cartons are particularly suitable, see Figure 73a) or plastic, providing they are ventilated; simply poke numerous holes in the container or its lid with an ordinary push pin or thumb tack (Figure 73b), and cover larger holes with a fine mesh screen or fabric. Untreated paper bags (lunch bags) work well for transporting biocontrol agents short distances; however, they are fragile and offer little physical protection for the material within, must be sealed tightly to prevent biocontrol agents from escaping, and some biocontrol agents are capable of chewing through them. **Do not use glass or metal release containers;** they are breakable and make it difficult to regulate temperature, airflow, and humidity.

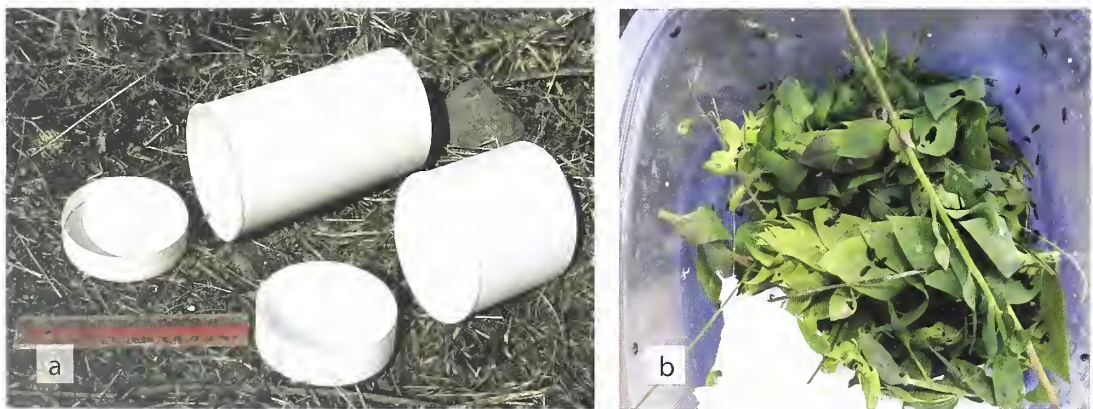

Figure 73. Containers for transporting toadflax biocontrol agents a. cardboard release containers (Martin Moses, University of Idaho, bugwood.org); b. plastic container with pinholes for ventilation on the sides, containing *Mecinus janthiniformis* and Dalmatian toadflax sprigs (Sharlene E. Sing, USDA FS RMRS)

Fill release containers half full with crumpled paper towels or tissue paper to provide a substrate for biocontrol agents to rest on and hide in, and to help regulate humidity. Fill the other half with toadflax sprigs. Sprigs must be inspected to ensure they are free of seeds, flowers, dirt, spiders, and other insects and should not be placed in water in the release container. Seal the release container lids either with masking tape or label tape. If you are using paper bags, fold over the tops several times and staple them shut. Be sure to label each container with (at least) the biological control agent(s) name, the collection date and site, and the name of the person(s) who did the collecting.

Transporting Toadflax Biological Control Agents

Keep the containers cool at all times: If you sort and package the biocontrol agents while in the field, place the release containers in large coolers equipped with frozen ice packs. Do not use ice cubes unless they are contained in a separate, closed, leak-proof container. Wrap the ice packs in crumpled newspaper or bubble wrap to prevent direct contact with release containers and to absorb any condensation that forms. Place extra packing material in coolers to prevent ice packs from shifting and damaging biocontrol agent containers. As an alternative to coolers with ice packs, electric car-charged coolers may be utilized, provided the cycle is set to cool and not warm. Always keep coolers out of direct sun, and only open them when you are ready to remove the biological control agent containers to place them in a refrigerator for overnight storage or to release the biocontrol agents. If you sort and package your agents indoors, keep them in a refrigerator (no lower than 40°F or 4.4°C) until you transport or ship them (which should occur as soon as possible but no longer than 48 hours).

Transporting short distances: If you can transport your biocontrol agents to their release sites within 3 hours after collection, and release them the same day or early the next, you need not take any measures other than those already described.

Shipping long distances: If you will be shipping your insects to their final destination, use a bonded carrier service with guaranteed overnight delivery (e.g., USPS, FedEx, UPS, or DHL) and send the recipient the tracking number for the package. In such cases, the release containers should be placed in insulated shipping containers with one or more ice packs. Some specially designed foam shippers have pre-cut slots to hold biocontrol agent containers and ice packs (Figure 74). This construction allows cool air to circulate but prevents direct contact between the ice and the release containers. Laboratory and medical suppliers sell foam “bioshippers” that are used to transport medical specimens or frozen foods. If neither foam product is available, you can use a heavy-duty plastic cooler. **Please note that for safety reasons, dry ice cannot be used for transporting biocontrol agents.**

Careful packaging is very important regardless of the shipping container you use. Ice packs need to be wrapped in crumpled newspaper, wrapping paper, or bubble wrap, and should be firmly taped to the inside walls of the shipping



Figure 74. Commercially made shipping container (University of Idaho, bugwood.org)

container to prevent them from bumping against and possibly crushing the release containers during shipping. Empty spaces in the shipping container should be loosely filled with crumbled or shredded paper, bubble wrap, packing “peanuts,” or other soft, insulating material. Use enough insulation to prevent release containers and ice packs from shifting during shipment, but not so much that air movement is restricted. Tape the release container lids shut. Enclose all paperwork accompanying the biocontrol agents (including copies of permits and release forms) before sealing the shipping container. For additional security and protection, you may place the sealed shipping containers or coolers inside cardboard boxes.

Other factors to consider

- Make overnight shipping arrangements well before you collect your biological control agents, and make sure the carrier you select can guarantee overnight delivery.
- Plan collection and packaging schedules so that overnight shipments can be made early in the week. Avoid late-week shipments that may result in delivery on Friday through Sunday, potentially delaying release of the agents for several days.
- Clearly label the contents of containers and specify that they are living insects.
- Check with a prospective courier to make sure that they can accept this type of cargo and will not treat the packages in ways that could harm the biological control agents. If the courier cannot guarantee that such treatments will not occur, choose a different carrier.
- Contact personnel at the receiving end, tell them what you are shipping and when it is due to arrive, provide a tracking number, verify that someone will be there to accept the shipment, and instruct them not open the container prior to releasing the agents.

Common Packaging Mistakes

Crushing- Secure all material included in the shipping container so that blue ice, bundles of plant material, etc. do not become loose and move around in transit thereby crushing, tearing or popping open release containers and killing or scattering the biocontrol agents inside.

Escape- Tape release containers securely with masking or other easily removable/resealable tape to prevent agents from escaping into the shipping container.

Excess heat- Do not expose release containers to direct sunlight or temperatures above 80°F (27°C). Avoid shipping delays that can expose agents to high temperatures.

Excess moisture- Remove spilled or excess water in release and shipping containers. Do not ship weed sprigs with any type of water source (e.g., floral foam or tubes) inside release containers; use only a small square of new, well-rinsed, moist but not damp cellulose sponge. Add crumpled paper towels to release containers to absorb incidental moisture or condensation.

Lack of ventilation- Provide adequate ventilation; use air-permeable release containers or make air holes in plastic containers with push pins or other small diameter tools.

Starvation- Provide sufficient food, and do not store release containers with biological control agents more than 48 hours. Larval *Calophasia lumula* eat constantly so they need to be shipped with abundant foliage.

Stress- Provide root-, flower- and seed-free sprigs of the target weed (free also of other weed species' seeds, flowers, dirt, spiders, or other insects) and crumpled paper towels where biocontrol agents can shelter; avoid over-crowding.

Purchasing Toadflax Biological Control Agents

A number of commercial suppliers provide toadflaxes biological control agents. In the USA, county weed managers, extension agents, or university weed or biological control specialists may be able to recommend one or more suppliers. Make sure that a prospective supplier is reputable, can provide copies of required permits, can provide healthy individuals of the species you want (parasite- and pathogen-free), and can deliver them to your area at a time appropriate for field release (you will want to know where and when the biocontrol agents were collected). Avoid purchasing agents from a supplier who collects biocontrol agents from an environment significantly different from your planned release location. Interstate shipments of toadflax biological control agents by commercial suppliers also require a USDA permit, a copy of which should be enclosed in the shipping box (see page 88). Confirm in advance that there is a permit in place for the species you are acquiring as well as the region in which the release will occur. **DO NOT** purchase or release unapproved or non-permitted biological control organisms. Note that before any agents can be taken across national borders, whether collected or purchased, an importation permit from the regulatory agency of the receiving country is required (USDA-APHIS in the USA and CFIA in Canada).

Releasing Toadflax Biological Control Agents

Establish permanent location marker: Place a steel fence post or plastic/fiberglass pole as a marker at the release point (Figure 75a). Avoid wooden posts; they are vulnerable to weather and decay. Markers should be colorful and conspicuous. Bright orange or pink are superior to red, blue, yellow and green, which can blend into surrounding vegetation. Where conspicuous posts may encourage vandalism, mark your release sites with short, colorful plastic tent/surveyor's stakes or steel plates that can be tagged with release information and located later with a metal detector and GPS.

Record geographical coordinates at release point using GPS: Map coordinates of the site marker should be determined using a global positioning system device (GPS) or a GPS-capable tablet/smartphone. There are numerous free apps available for recording GPS coordinates on a tablet/smartphone (Figure 75b). Coordinates should complement but not replace a physical marker. Accurate coordinates will help re-locate release points if markers are damaged or removed. Along with the coordinates, be sure to record what coordinate system and datum you are using, e.g., latitude/longitude in WGS 84 or UTM's in NAD83.

Prepare map: The map should be detailed and describe access to the release site, including roads, trails, and relevant landmarks.

Use your vehicle's trip odometer to measure and record mileage between specified locations on your map, e.g., when you turn on to a new road, at cattle guards along the route, and where you park. The map should complement but not replace a physical marker and



Figure 75. Biocontrol agent release site tools a. permanent marker; b. smartphone with free weed and biocontrol agent mapping app iBioControl (a,b Rachel Winston, MIA Consulting)

GPS coordinates. Maps are especially useful for long-term biological control programs in which more than one person will be involved or participants are likely to change. Maps are often necessary to locate release sites in remote locations or places physically difficult or confusing to access.

Complete relevant paperwork at site: Your local land management agency/authority may have standard biocontrol agent release forms for you to complete. Typically, the information you provide includes a description of the site's physical location, including GPS-derived latitude, longitude, and elevation; a summary of its biological and physical characteristics and land use; the name(s) of the target weed and biocontrol agent(s) released; date and time of the release; weather conditions during the release; and the name(s) of the person(s) who released the agents (see Sample Biological Control Agent Release Form in Appendix II). The best time to record this information is while you are at the field site. Consider using a smartphone and reporting app such as iBioControl. This free application uses EDDMapS (see page 90 for more information) to help county, state, and federal agencies track releases and occurrences of biological control agents of noxious weeds. Once back in the office, submit the information to your local weed control office, land management agency, or other relevant authority/database. Always keep a copy for your own records.

Set up photo point: A photo point is used to visually document changes in toadflax infestations and the plant community over time following the release of biocontrol agents. Use a permanent feature (landmark) in the background as a reference point (e.g., a mountain, large rocks, trees, or a permanent structure) and make sure each photo includes your release point marker. Avoid capturing images that mostly show only the target weed without reference points that can identify specific release sites. Pre- and post-release photographs should be taken from roughly the same place and at the same time of year (Figure 76a,b). Label all photos with the year and location.



Figure 76. Multi-year photos of a Dalmatian toadflax biocontrol agent release site at Oster, Idaho utilizing permanent geographical features in the background and taken from roughly the same place and time in both years a. 2003; b. 2010 (a,b Joseph Milan, BLM/ISDA)

Release as many agents as possible: As a general rule of thumb, it is better to release an adequate number of individuals of a biocontrol agent species on one toadflax infestation than it is to spread those individuals too thinly over multiple toadflax infestations. Releasing all the agents within a release container in one spot will help ensure that a sufficient number of males and females can find one another to reproduce; this also reduces the risks of inbreeding and other genetic problems. An optimal release of the defoliating moth, *Calophasia lunula*, would consist of at least 100 larvae; however, redistributions of this biocontrol agent are not recommended because of nontarget feeding concerns. Generally for toadflax beetles, a minimum release of 200 insects is recommended to establish a population. You may want to release 500 or more beetles if you want to establish an insectary site for future collecting.

Often, a single release will be sufficient to establish an insect population, especially if a large number (500 or more) of insects were released. The only way to determine if biocontrol agents have established is to inspect them annually for up to 5 years (or more) after releases were made. Subsequent releases may be necessary if initial releases fail to establish. For species or locations where establishment is likely to be slow (e.g. due to high levels of overwintering mortality), planning to make releases on the same site for 2 or 3 consecutive years may increase successful establishment and reduce the time until agent impact on target weed populations is seen. If more than one release is available in a given year, be sure to put some distance between releases; 1 km ($\frac{2}{3}$ mile) is ideal. If possible, make more than one release per drainage or in adjoining drainages; if one of your releases is wiped out by flooding, fire, herbicide application or other catastrophic disturbance, then biocontrol agents from adjoining releases can repopulate it. Strategically releasing biocontrol agents in adjoining weed infested drainages can over time lead to sustainable, effective suppression of toadflaxes at a landscape level.

Mecinus spp. weevils typically travel uphill rather than downhill to colonize uninfested host plants, so releases of this biocontrol agent should be made at the bottom of weed infested hillsides. When releasing by transferring toadflax stems infested with *Mecinus* spp., remove the ties on one end of each bundle. Fan out the stems at the loose end of the bundle so adult weevils can easily escape from the stems (Figure 71c). Deposit bundles into dense patches of toadflax on uncolonized sites.

In general, you can release biocontrol agents either in open or caged releases. Caged releases prevent immediate dispersal of biocontrol agents but require you to put up and take down equipment. For open releases, get to the desired release location, open the release container, and gently shake out all insects and toadflax stems and foliage in one small area (Figure 77a). **Do not scatter biocontrol agents throughout the infestation. Do not walk back over the area where you just made a release.** Make sure the toadflax stems in the release container do not have any immature or mature seeds on them before dumping them out at the new site. Gently dislodge any insects hiding in or clinging to the paper towels in the release containers. For caged releases, place a mesh bag over a toadflax plant or a caged area containing multiple plants (Figure 77b), release insects into the cage, and secure the bottom of the cage to either the stem or the ground. Cages confine the insects for a period of time so they adjust to the site and easily find one another. Cages should be removed after a few weeks to prevent them from being vandalized or damaged by animals or weather.

It is most effective to collect biocontrol agents and release them on the same host species (i.e. if collecting from Dalmatian toadflax, then release those onto Dalmatian toadflax). Releases of all biocontrol agents should be made under moderate weather conditions (mornings or evenings

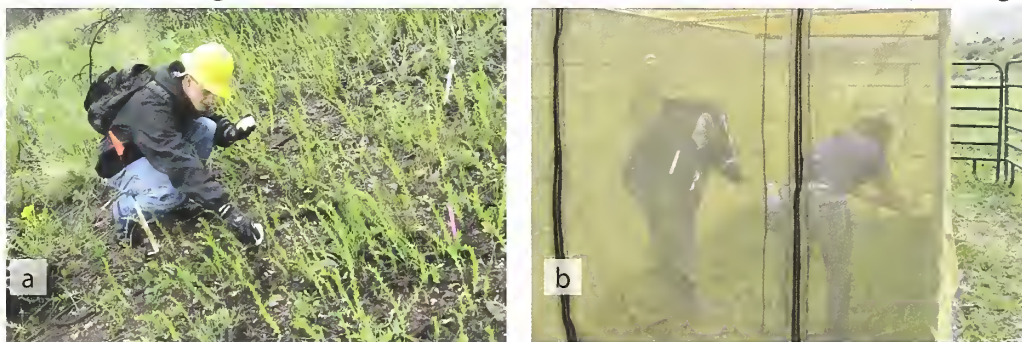

Figure 77. Releases of *Mecinus* spp. a. open release of *M. janthiniformis* on Dalmatian toadflax (Curt Leibrand, USDA FS RMRS); caged release of *M. janthinus* on yellow toadflax (Carol Bell Randall, USDA FS)

of hot summer days, mid-day for cold season releases). Making releases under these conditions reduces the immediate dispersal of stressed agents when they are dumped out of release containers; appropriately timed releases can significantly enhance the probability of establishment. If you encounter an extended period of poor weather, however, it is better to release the insects than wait three or more days for conditions to improve as the agents' vitality may decline with extended storage. Do not worry if it snows after you made your release – biocontrol agents are well adapted to most field conditions and cold, wet conditions are preferable to hot, dry conditions for making releases. Avoid transferring biocontrol agents to areas with obvious ant mounds or signs of ground dwelling animals that may prey upon biological control agents.

Regulations for the Transfer of Toadflax Biological Control Agents

USA, intrastate

Generally, there are few if any restrictions governing collection and shipment of approved biological control agents within the same state; however, you should check with your state's department of agriculture or agriculture extension service about regulations governing the release and intrastate transport of your specific biological control agent. The state of California regulates release permits at the county level.

USA, interstate

The interstate transportation of biological control agents is regulated by the U.S. Department of Agriculture (USDA), and a valid permit is required to transport living biological control agents across state lines. You should apply for a Plant Protection and Quarantine (PPQ) permit from the Animal and Plant Health Inspection Service (APHIS) as early as possible—but at least six months before actual delivery date of your biological control agent. You can check the current status of regulations governing intrastate shipment of weed biological control agents, PPQ Form 526 at the USDA-APHIS-PPQ website. The permit process can be accessed by doing an Internet search for “USDA APHIS 526 permit application”. This allows the complete online processing of biological control agent permit requests.

Canada

Canada requires an import permit for any new biological control agent or shipments from overseas of previously released agents. Permits are issued by the Plant Health Division of the Canadian Food Inspection Agency. Redistribution within a province (or even within Canada) of weed biological control agents that have been officially approved for use in Canada is generally allowed; however, you should consult with provincial and federal authorities and specialists prior to moving any weed biological control agent between areas (e.g., from the prairies to the interior or coast of British Columbia). Accidentally introduced biocontrol agents that have become adventive in a region, or native organisms that may feed on a weed targeted for control should not be moved to new areas without consulting federal authorities and specialists as their host range or potential ecological impacts are not fully known.

Documenting, Monitoring, and Evaluating a Biological Control Program

The Need for Documentation

The purpose of monitoring is to evaluate the success of your toadflax biological control program and to determine if you are meeting your weed management goals. Documenting outcomes (both successes and failures) of biocontrol release programs will help generate a more complete picture of biocontrol impacts, guide future management strategies, and serve education and public relations functions. Monitoring can provide critical information for other land managers by helping them predict where and when biological control might be successful, helping them avoid releasing ineffective biocontrol agents or the same biocontrol agent in an area where they were previously released, and/or helping them avoid land management activities that would harm local biocontrol agent populations or worsen the toadflax problem. (See the Code of Best Practices for Classical Biological Control of Weeds on page 5.)

Monitoring activities utilize standardized procedures over time to assess changes in populations of the biocontrol agents, toadflaxes, other plants in the community, and other components of the community. Monitoring can help determine:

- If biological control agents have become established at the release site
- If biological control agent populations are increasing or decreasing, and how far they have spread from the initial release point
- If biological control agents are having an impact on toadflaxes
- If/how the plant community or site factors have changed over time

Monitoring methods can be simple or complex. A single year of monitoring may demonstrate whether or not the biocontrol agents established, while multiple years of monitoring may allow you to follow the population of the biocontrol agents, the decline of the target weed, changes in the plant community, and changes in other factors such as climate or soil.

Information Databases

Many federal and state/provincial departments have electronic databases for archiving information about weed biological control releases. We have included a standardized biological control agent release form that, when completed, should provide sufficient information for inclusion in any number of databases (see Appendix II).

At the federal level in the USA, the USDA Animal and Plant Health Inspection Service (APHIS) maintains the Cooperative Agricultural Pest Survey (CAPS) database, which is part of the National Agricultural Pest Information System (NAPIS). Biological control agent release information is entered into CAPS by a number of state and federal agency personnel who serve on the state's CAPS survey committee. Contact your local APHIS officials or state department of agriculture for more information on participation. Similarly at the federal level in Canada, Agriculture and Agri-Food Canada maintains a database of initial releases of all biocontrol agents permitted by CFIA for use.

The USDA Forest Service maintains a database of biological control agent releases on federal and non-federal lands. As of the writing of this document, weed biocontrol agent releases made on Forest Service lands are entered into the Forest Service Activity Tracking System (FACTS)

database. Other agencies may maintain their own databases for this information. Many of the databases maintained by state and federal agencies have safeguards in place to prevent exploitation of the information they contain.

The USDA Forest Service (in conjunction with the University of Georgia, MIA Consulting, University of Idaho, CAB International, and the Queensland Government) also maintains a worldwide database for the Biological Control of Weeds: A World Catalogue of Agents and their Target Weeds. The database includes entries for all weed biocontrol agents released through 2014, including the year of first release within each country, the biocontrol agents' current overall abundance and impact in each country, and more. This database can be accessed at www.ibiocontrol.org/catalog/.







EDDMapS (Early Detection & Distribution MAPping System) is a web-based mapping system increasingly being used for documenting invasive species as well as biocontrol agent distribution in North America. EDDMapS combines data from existing sources (e.g. databases and organizations) while soliciting and verifying volunteer observations, creating an inclusive invasive species geodatabase that is shared with educators, land managers, conservation biologists, and beyond. Information can be added in online forms through home computers and/or apps created for smartphones. For more information on how to utilize or contribute to these tools, visit www.eddmaps.org and apps.bugwood.org.

Monitoring Methods

There are three main components to measure in a toadflax monitoring program: biological control agent populations, toadflax populations, and the rest of the plant community (including nontarget plants). More detailed monitoring might also examine effects on other biotic community components (such as other insects, birds, mammals, etc.) or abiotic factors (such as erosion, soil chemistry, etc.). Only the three main monitoring components are discussed in this manual.

Assessing biological control agent populations: If you wish to determine whether or not toadflax biocontrol agents have established after initial release, you simply need to find the agents in one or more of their life stages, or evidence of their presence (Table 9). Begin looking for biocontrol agents where they were first released, and then expand to the area around the release site.

Table 9. Life stages/damage to look for to determine establishment of toadflax biological control agents (*Eteobalea* spp. are not included as these root moths have not been confirmed as established in North America). a. *Brachypterolus pulicarius* adults congregating on toadflax buds and flowers (Susan Turner, British Columbia Ministry of Forests); b. *B. pulicarius* larva (Daniel K. Mackinnon, Colorado State University); c. *Calophasia lunula* cocoon (Gary Piper, Washington State University); d. *C. lunula* larvae defoliating toadflax (Laura Parsons & Mark Schwarzländer, University of Idaho); e. *M. janthiniiformis* adult feeding damage on foliage (Carol Bell Randall, USDA FS); f. *M. janthiniiformis* larval mines in toadflax stem (Laura Parsons, University of Idaho); g. *Mecinus* spp. adult (Bob Richard, USDA APHIS PPO); h. yellow toadflax dying from *M. janthinus* larval mining (Sharlene E. Sing, USDA FS RMRS); i. *Rhinusa antirrhini* adults on toadflax flowers; j. *R. antirrhini* larvae in swollen seed capsules (i-j Eric Coombs, Oregon Department of Agriculture); k. *R. linariae* adult (Bob Richard, USDA APHIS PPO); l. *R. linariae* galls on yellow toadflax stem (Ivo Toševski, CABI); m. *R. neta* adult (Gyorgy Csoka, Hungary Forest Research Institute)

AGENT	LIFE STAGE	WHERE TO LOOK	WHEN TO LOOK	WHAT TO LOOK FOR	APPEARANCE
<i>Brachypterolus pulicarius</i> Toadflax flower-feeding beetle	Adults	Toadflax shoot tip leaves and buds; flowers	May to June	Feeding damage (holes) in the side of flowers, or on shoot tips leaves and buds; adults congregating on toadflax buds and flowers to lay eggs	
	Larvae	Inside toadflax flowers	June to September	Larvae feeding within flowers on pollen, anthers, ovaries and immature seeds	
<i>Calophasia lunula</i> Toadflax defoliating moth	Adults	Toadflax stem bases, plant litter, soil beneath toadflax plants	August through April	Cocoons made of silk, chewed leaves and soil attached to stem bases, plant litter, or soil	
	Larvae	Toadflax foliage	June to September	Extensive defoliation of upper half of shoots; groups of actively feeding larvae on foliage; feeding damage focused on the edge of leaves.	
<i>Mecinus janthiniiformis</i> Dalmatian toadflax stem-mining weevil	Adults	Toadflax shoot tips, foliage	April to late June	Intense shot-hole feeding damage focused on foliage and buds at tops of stems; adults congregating on leaves and stems to mate and lay eggs.	
	Larvae	Inside toadflax stems	May to July	Larvae mining inside stems; dead plants; plants with shoot tips curled and leaning over, stunted growth and limited flowering.	

AGENT	LIFE STAGE	WHERE TO LOOK	WHEN TO LOOK	WHAT TO LOOK FOR	APPEARANCE
<i>Mecinus janthinus</i> Yellow toadflax stem-mining weevil	Adults	Toadflax shoot tips, foliage	March to mid-June	Minor shot-hole feeding damage on toadflax foliage; adults congregating on upper leaves and stems to mate and lay eggs.	
	Larvae	Inside toadflax stems	April to late June	Larvae mining inside stems; dead plants; plants with twisted shoot tips, stunted growth, and limited flowering	
<i>Rhinusa antirrhini</i> Toadflax seed-galling weevil	Adults	Toadflax shoot tips, buds, flowers	May to mid-July	Feeding damage on flowers or shoot tips; adults congregating on toadflax buds and flowers to lay eggs	
	Larvae	Inside toadflax flowers	July to August	Spur on swollen seed capsules; swollen, watery pale seeds; larvae feeding on seeds.	
<i>Rhinusa linariae</i> Toadflax root-galling weevil	Adults	Toadflax shoots, root crowns	May	Feeding damage on stems; adults congregating at root crowns to lay eggs.	
	Larvae	Galled tissue of toadflax roots	June to July	Galls extending downward from toadflax root crowns; larvae feeding in galled tissue	

AGENT	LIFE STAGE	WHERE TO LOOK	WHEN TO LOOK	WHAT TO LOOK FOR	APPEARANCE
<p><i>Rhinusa neta</i> Toadflax seed-feeding weevil</p>	Adults	Toadflax shoot tips, buds, flowers	May to mid-July	Feeding damage on flowers or shoot tips; adults congregating on buds and flowers to lay eggs	
	Larvae	Inside toadflax flowers	July to August	Larvae feeding within seed capsules on immature seeds (neither the seed capsules nor the seeds are swollen)	

Populations of some biocontrol agents may take two to three years to build to detectable levels. If no biocontrol agents are detected a year after release, it does not mean they failed to establish. Revisit the site at least once annually for three years. If no evidence of biocontrol agents is found, either select another site for release or make additional releases at the monitored site. Consult with your county extension educator or local biological control of weeds expert for assistance.

A systematic monitoring approach is required to determine the changing densities of biocontrol agent populations. The Standardized Impact Monitoring Protocol (SIMP) is one such approach to monitoring biocontrol agent populations, weed populations, and the surrounding plant community over time (Appendix III). This protocol was cooperatively developed by the Bureau of Land Management, the University of Idaho, USDA Forest Service Forest Health Protection, the Nez Perce Biocontrol Center, and the Idaho State Department of Agriculture. SIMP was designed to be simple, efficient, and sufficiently versatile to allow for the collection of information from the same sites over multiple years. The SIMP method can be easily modified to meet your personal or agency needs for toadflaxes. For example, rather than counting adult *Mecinus* spp. during repeated sweep intervals, one could count the number of *Calophasia lunula* larvae (or any other agent species-life stage combination) present on toadflax foliage during a timed interval. An alternative general toadflax biological control agent monitoring form can be found in Appendix IV. Feel free to modify existing data sheets by adding extra columns, descriptive classes, etc. to satisfy your monitoring needs.

Assessing the status of toadflaxes and co-occurring plants: The ultimate objective of a toadflax biological control program is to permanently reduce the abundance of toadflaxes and enable the recovery of more desirable vegetation on the site. To determine the efficacy of biocontrol efforts, there must be monitoring of plant community attributes, such as target weed distribution and density. Ideally, monitoring begins before biological control efforts are started (pre-release) and at regular intervals after release. There are many ways to qualitatively (descriptively) or quantitatively (numerically) assess weed populations and other plant community attributes at release sites.

Qualitative (descriptive) vegetation monitoring: Qualitative monitoring uses subjective measurements (words, images, or objects) to describe toadflaxes and the rest of the plant community at the management site. Examples include listing plant species occurring at the site, estimating density, age and distribution classes, visual infestation mapping (as opposed to mapping with a GPS unit), and a series of photos from designated photo points through time (Figure 78a,b). See Appendix V for a sample data form where you can record qualitative toadflax monitoring data along with information on associated vegetation. Qualitative monitoring provides insight into the status or change of toadflaxes populations. However, its descriptive nature does not generally allow for detailed statistical analyses. Data obtained in qualitative monitoring may trigger more quantitative monitoring later.

Quantitative vegetation monitoring: Quantitative monitoring measures changes in the toadflax population as well as the vegetative community as a whole before and after a biocontrol agent release using numbers and statistics. It may be as simple as counting the number of toadflax stems in a small sample area, or as complex as measuring toadflaxes plant height, flower and seed production, biomass, species diversity, and species cover (Figure 79a,b).



Figure 78. Dalmatian toadflax infestation with large populations of *Mecinus janthiniformis* a. in 2010; b. in 2011 in Idaho County, Idaho (a,b Rachel Winston, MIA Consulting)



Figure 79. Monitoring a. measuring toadflax density; b. estimating toadflax cover (Sharlene E. Sing, USDA FS RMRS)

Quantitative sampling data can be more readily analyzed using statistical methods and demonstrate significant plant community changes. Pre- and post-release monitoring should follow the same protocol and be employed at the same time of year. Post-release assessments should be planned annually for at least three to five years after the initial biocontrol agent release.

The SIMP approach described earlier and found in Appendix III is a combination of qualitative and quantitative monitoring elements. See Appendix VI for a sample data form where you can record qualitative toadflax monitoring data along with information on associated vegetation.

Assessing impacts on nontarget plants: To address possible nontarget attacks on species related to toadflaxes, you must become familiar with the plant communities present at and around your release sites and be aware of species present that are related to toadflaxes. Start by compiling a list of the Plantaginaceae species present that are closely related to the *Linaria*, including native and exotic species of snapdragons, and native toadflaxes in the genus *Nuttallanthus*. You may need to consult with local, state, or regional botanical experts, or review local herbarium records for guidance on areas where related nontarget plants might be growing and additional information on how you can identify them. Care should be taken in the management of your toadflax biocontrol program to ensure that all related native species are identified and monitored along with toadflaxes.

If you observe approved biocontrol agents feeding on and/or developing on nontarget species, the vegetation sampling procedures described above can be easily modified to monitor changes in density and/or cover of the nontarget species. Concurrently, you may wish to collect additional data, such as the number of agents observed on nontarget plants, the amount of foliar attack observed, or the presence of characteristic biocontrol agent damage. Collecting this data over subsequent years can help determine if there is a population level impact or if the nontarget feeding is temporary or of minor consequence to the nontarget species. Please be aware that there are many “look-alike” native insects that feed on related native plants. Correct identification by insect specialists is needed to confirm such records.

If you observe approved biological control agents feeding on and/or developing on native species, collect samples and take them to a biocontrol specialist in your area. Alternatively, you may send the specialist the site data so he or she can survey the site for nontarget impacts. Be sure not to ascribe any damage you observe on native species to any specific species and thus bias the confirmation of attack and the identification of the species causing the attack.

CHAPTER 5: AN INTEGRATED TOADFLAX MANAGEMENT PROGRAM

Introduction

Classical biological control has been applied to many invasive plant species, and there are several examples in which both single- and multiple-biocontrol agent introductions have successfully controlled the targeted weeds. At some locations, biological control can maintain toadflax densities below economically or ecologically significant levels, enabling land managers to live with the weed; however, it may take three to five years or more for biological control to reduce weed populations to such manageable levels. Furthermore, toadflaxes occur across a wide range of conditions. Some habitats are unsuitable to biocontrol agents, so biological control is not going to work against toadflaxes every time at every site. Depending on the infestation, integration with other weed control methods or resorting to other control measures entirely may be required to attain toadflax management objectives. A wide variety of successful weed control methods have been developed and may be useful for helping meet management goals for toadflaxes. The most successful long-term toadflax management efforts have a number of common features, including:

- Education and Outreach
- Inventory and Monitoring
- Prevention
- Weed Control Activities: A variety of toadflax control activities which are selected based on characteristics of the target infestation and planned in advance to use the most appropriate method or combination of methods at each site, including:
 - Biological control
 - Physical treatment
 - Cultural practices
 - Chemical treatment

Programs that incorporate many of these activities are called Integrated Weed Management (IWM) programs, and they address several aspects of land management, not just weed control. Land managers or landowners engaged in IWM take the time to educate themselves and others about the threat invasive plants pose to the land. They get out on their land and look for potential threats, including toadflaxes. When an infestation is found, they map it and make plans to address it utilizing single or combined control methods most appropriate for their particular infestation. After initiating control activities, they monitor if the control efforts were

successful. If re-treatment or additional treatments are necessary, these are applied in a timely manner with appropriate post-treatment monitoring to ensure that management objectives are being met.

Integrated Weed Management programs undertaken on a landscape level over many years can at times prove logistically difficult, expensive, and time-consuming. The concept of Cooperative Weed Management Areas (CWMA) was created in western North America in order to erase jurisdictional boundaries and make a landscape approach to weed management more feasible and successful. CWMA's consist of federal, state and local land managers, as well as concerned private landowners, within a delineated area who join efforts against exotic plants, pooling and stretching limited resources and manpower for managing invasive species and protecting/restoring habitat. Cooperation between neighboring CWMA's helps transfer knowledge and experience between heavily treated regions and places not yet as impacted by toadflaxes. Sharing successes and failures in toadflax management saves time and funding and reduces the incidence of negative impacts from management efforts, such as herbicide resistance. Numerous CWMA's exist throughout the western states of the USA and are excellent sources of information, experience, and resources for treating toadflax infestations using an IWM approach.

The components of toadflax IWM are described individually below. Because the focus of this manual is the biological control of toadflaxes, the potential to integrate biocontrol with other weed control methods is described at the end of each control method's section. Long-term management success is greatly improved when control methods are identified according to infested habitat type, land use, ownership, and available resources and then integrated when appropriate.

Components of Successful Integrated Weed Management Programs to Manage Toadflaxes

Education & Outreach

Education and outreach activities increase public awareness of noxious weeds, the problems they cause, their distribution, and ways to manage them (Figure 80). Ideally, education and outreach activities also foster cooperation and collaboration across land ownership boundaries to facilitate the development of a landscape-level weed management response. Education efforts should be an important component of any weed management plan, regardless of the target weed or weed control method employed.



Figure 80. Dalmatian toadflax education poster (University of Nevada, Cooperative Extension)

Toadflax education and outreach should focus on conveying to the public:

- the threat toadflaxes pose
- how to identify toadflaxes (and their hybrids) in different stages
- the importance of not utilizing/planting toadflaxes or their hybrids in any setting
- ways in which they can help in toadflax management

By educating land managers and landowners, recreationalists and the public about the threat of toadflaxes, enabling them to identify infestations, and enlisting them in mapping and management efforts, it becomes possible to cooperatively develop successful weed management responses at the landscape level.

Inventory & Mapping

Inventory and mapping are key elements of a successful weed management program. It is imperative to accurately characterize the size and extent of weed infestations before control activities are identified, prioritized, and implemented because the best treatment methods are often determined by the size and location of the infestation. Education and outreach activities that foster collaboration between adjacent landowners are particularly useful when developing landscape-level maps of weed infestations. Once land managers and landowners fully understand the threats toadflaxes pose to their land, they are often more willing to participate to ensure that their land is inventoried and accurate maps of toadflax are developed so the best control activities can be implemented.

Toadflax infestations are often mapped by foot, vehicle, horse, or airplane using a global positioning system unit (GPS) and a geographical information system (GIS), though hard copy maps made by hand are suitable for some locations. An exciting recent development is the increasing use of free smartphone and tablet apps that make accurate, detailed, and versatile weed mapping available to anyone (e.g. the apps available from EDDMapS, see page 90 for more information). Inventory efforts should document the following for each infestation: location coordinates, boundaries, estimated density (number of stems of target weed per area, e.g. square meter or square yard), land usage, treatment history, disturbance history (e.g. fire, flooding), habitat type (wetland, upland, shrubland, grassland), and date. Photos of the infestation and a list of co-occurring species are also very useful. Documenting inventory and mapping efforts enables land managers to determine if all known toadflax infestations have been treated, and facilitates post-treatment monitoring. In turn, this allows land managers to judge the effectiveness of various treatment methods. See Chapter 4 for suggested techniques of monitoring infestations.

Prevention

Prevention activities focus on areas not currently infested by toadflaxes with the goal of keeping these areas weed-free. Though toadflaxes are already present throughout much of North America, there are many sites where they are absent or remain at low densities. Inventory efforts help identify the precise borders of these locations. Preventing the introduction and spread of toadflaxes to uninfested areas is more environmentally desirable and cost-effective than treating of large-scale infestations.

Toadflaxes are spread by the movement of seed by humans and animals (livestock and wildlife), primarily along transportation corridors such as rivers, roads, recreation and game trails, and rail lines. Seeds can be caught on motorized equipment, mud on tires or clothing, hay, or animal fur. Because seeds ingested by animals often remain viable upon defecation, livestock, birds, elk, and deer grazing toadflax fruits in autumn is one of the primary modes of toadflax long distance seed dispersal. Limited seed dispersal of yellow toadflax may occur by wind, and both toadflaxes and their hybrids may be spread short distances locally by insects and rodents. Root fragments can also spread toadflaxes into uninfested areas. Preventing the spread of toadflaxes requires cooperation among all affected landowners and land managers. In areas where toadflaxes are not yet present, it is important to ensure that possible invasion avenues are identified and management actions taken to reduce the risk of spread. This includes minimizing soil disturbances and regularly monitoring uninfested sites to confirm that they have remained uninfested.

Cultivation, soil erosion (especially following flooding events and prescribed or wildfire), road grading, recreational activities (e.g. riding dirt bikes or four wheelers), and overgrazing all weaken existing plant communities, decrease plant cover, and cause disturbance, conditions that favor toadflax establishment and persistence (Figure 81). Because such activities are also potential ways of spreading toadflax seeds, they should either be avoided or closely monitored in toadflax-prone areas. Where grazing does occur, proper livestock management (such as strategic timing and stocking rates) will allow grazed vegetation to recover and competitive plants to increase which, in turn, will help prevent the establishment of toadflaxes. If possible, livestock should be kept off weed-infested land when they are most likely to spread viable seeds (e.g. after seed formation). If it is not possible to avoid driving vehicles and machinery (e.g. logging, construction, or rangeland fire-fighting equipment) through toadflax infestations, it is crucial that a thorough cleaning take place before equipment leaves the contaminated area.

Prevention and exclusion activities are typically paired with education efforts. Examples of exclusion efforts include weed-free forage programs, state and provincial seed laws, and mandatory equipment cleaning when leaving infested sites and before entering uninfested sites.

EDRR

An early detection and rapid response (EDRR) program is a specific protocol for tracking and responding to new infestations. It relies heavily on education and outreach activities to be effective. An EDRR program targets areas where toadflaxes may spread. It consists of three complementary activities: 1) educating land managers and the public on weed identification and mapping techniques, 2) enlisting their aid in immediate and thorough detection of the weed and 3) initiating rapid response eradication efforts at all verified locations of the weed.



Figure 81. Dalmatian toadflax growing in soil disturbed by railroad activities (Steve Dewey, Utah State University, bugwood.org)

Weed Control Activities

Biological Control

Biological control involves the use of living organisms, usually insects, mites, or pathogens, to control a weed infestation and regain the balance among coexisting plant species. Classical biological control focuses on the introduction of host specific natural enemies from the invasive weed's native range. This method of toadflax management is the most economical and suitable control option for larger infestations (tens to thousands of acres), though some smaller infestations have shown great suppression by biocontrol agents. For small patches (less than 4 acres or 1.6 hectares) of new satellite (those growing outside of well-established) toadflax infestations, more aggressive control methods should be utilized (e.g. physical control or herbicides). Refer to Chapter 3 for detailed descriptions of the biological control agents currently approved for use against toadflaxes and Chapter 4 for how to implement a toadflax biological control program in your area.

Physical Treatment

Physical treatment utilizes hand pulling, mowing, or tilling to remove or disrupt the growth of weeds and is the oldest method of weed control. Physical methods have had variable success in controlling toadflaxes but are often labor-intensive and not suitable for the more rugged and inaccessible sites where toadflaxes have invaded. Due to toadflax's ability to regenerate from severed root fragments, extreme care must be taken to ensure physical control methods are carried out under the appropriate conditions so that toadflax populations do not increase as a result of control efforts. Regardless of the physical method employed, it is imperative that all equipment used be thoroughly cleaned following use to prevent the spread of toadflax seeds or propagating root or stem fragments.

Hand pulling

Hand pulling can provide successful control of small toadflax infestations (under 1 acre or 0.4 ha) if applied persistently. It is especially effective on young plants growing in sandy, moist, and/or loose soil (Figure 82). As plants age, or for plants growing in compacted soils, hand pulling can increase the size of the infestation due to seedling recruitment in the newly disturbed soil, and to regeneration from the severed roots of pulled plants. To account for this plant response, small populations of older toadflaxes individuals must be pulled several times a year and often for multiple years. Multiple hand-pulling sessions will also control new toadflax individuals sprouting later in the growing season from seeds lying dormant in the seed bank.

It is important to remove as much of the toadflax root as possible, while minimizing soil disturbance. When toadflax plants are in flower or seed, cut off and bag all flowering stems prior to pulling. Otherwise, the jarring action of pulling may dislodge and distribute seeds at the site. All roots, stems, flowers and seeds should be securely bagged and taken to the trash or a transfer site to prevent possible toadflax vegetative growth or seed dispersal from pulled material. Re-seeding the open space resulting from toadflax removal with seeds of desirable vegetation can provide competition that will decrease successful toadflax seedling germination and establishment.

Due to the destructive nature of hand pulling, this control method is not compatible with

biological control. Hand pulling is most appropriate for small infestations where immediate eradication is feasible, while biological control is more appropriate for much larger, established infestations. One way to successfully combine these two methods is to release biological control agents in a large, main infestation while employing hand pulling to remove individual plants and to control small, satellite patches arising outside of the main toadflax infestation.



Figure 82. Hand pulling Dalmatian toadflax (Rachel Winston, MIA Consulting)

Mowing

Mowing toadflaxes may decrease seed production. Though this can decrease the rate of toadflax spread by seed, it does not alter the existing seedbank and does not kill toadflax plants. In many cases, mowing may exacerbate the problem by stimulating toadflax re-growth (and subsequent flowering) and reducing competition from surrounding vegetation. Multiple mowing events are necessary in order to truly decrease toadflax seed production. However, long-term mowing of yellow toadflax populations can result in toadflax plants growing shorter and successfully flowering and setting seed beneath the mower height (Figure 83a). Frequent mowing of toadflaxes is not feasible in either the crop or rangeland setting where toadflaxes are so problematic in North America, but it may provide control of toadflaxes along roadsides and rights-of-way. Alternatively, mowing can be used to remove excess plant litter and overgrowth, which will improve the effectiveness of herbicide applications on toadflax re-growth. When mowing is used as a form of toadflax control, it is important that mowing treatments occur after plants flower but before seed production, because mowing can facilitate seed dispersal. This can be especially difficult to time properly in populations where plants flower at different times.

The destructive nature of mowing is damaging to the larvae of *Brachyterolus pulicarius*, *Calophasia lumula*, *Mecinus* spp., *Rhinusa antirrhini*, and *R. neta*, all of which utilize above-ground parts of toadflaxes. Mowing is more compatible with the root-galling weevil, *Rhinusa linariae*, as larvae and pupae can be found in galls in the roots of toadflax. Adults of all toadflax beetle species are susceptible to mowing while feeding on toadflax shoot tips, foliage, and flowers.



Figure 83. Physical control of toadflax a. mowed patch where yellow toadflax plants have re-grown and successfully flowered lower than the height of the mower (Hal Pearce, USDA FS); b. tilled field (background) infested with Dalmatian toadflax, with a few scattered Dalmatian toadflax plants in the foreground (Sharlene E. Sing, USDA FS RMRS)

Tilling

Tilling can be an effective form of control for yellow and Dalmatian toadflax if it is repeated every 7-10 days throughout the growing season, and repeated for multiple growing seasons. A single cultivation event can make the toadflax problem worse (Figure 83b) because toadflaxes are capable of regenerating from root fragments as small as 0.4 inches long (1 cm). Repeated tilling is not compatible with agricultural practices in active croplands where yellow toadflax is frequently a problem. In general, cultivation is not practical or desirable in the wildlands and rangelands where toadflaxes are so problematic in North America. Where repeated tilling is feasible, toadflax control is enhanced when an herbicide treatment is used in conjunction with cultivation, particularly to control the spread and regeneration of toadflaxes from root fragments. Sowing competitive pasture species or crops and adding fertilizer may also help prevent re-infestation by toadflaxes.

Because cultivation destroys above-ground growth and can slice toadflax roots into numerous fragments, this form of weed control is typically destructive to all established species of toadflax biocontrol agents. Repeated tilling is most applicable in a crop setting, where chronic disturbance and the need to attain immediate control make biological control fundamentally incompatible.

Cultural Practices

Cultural methods of weed control (including flooding, burning, grazing, and seeding with competitive species) can enhance the growth of desired vegetation, which in turn provide a barrier that slows the invasion of noxious weeds onto at-risk sites. Regardless of which method is used, all cultural control techniques are more successful when combined with other control methods.

Flooding and Burning

For toadflax management, flooding is typically not practical due to logistical challenges posed by the location and landscape scale of many toadflax infestations. Burning has also largely been dismissed as ineffective. While above-ground growth can be destroyed by prescribed or wildfires, the extensive root systems of toadflaxes survive even the hottest fires and readily re-

sprout viable shoots. Toadflax re-growth thrives and proliferates in the disturbed, nutrient-rich soil, especially if competition from other plant species is reduced or eliminated following the fire. While fire often exacerbates the problem, it has been used intentionally in some locations to burn off plant litter in order to make the re-sprouting toadflaxes more visible for applying herbicides (Figure 84). When prescribed fire kills off competing vegetation, it will only increase the toadflax problem, even with subsequent herbicide applications. Revegetation with desired vegetation is recommended wherever fire is utilized to aid in toadflax chemical control.



Figure 84. Burning toadflax with prescribed fire (David Cappaert, Michigan State University, bugwood.org)

High temperature fires destroy the larvae and potentially many adults of *Brachypterochus pulicarius*, *Calophasia lunula*, *Mecinus* spp., *Rhinusa antirrhini*, and *R. neta*, all of which utilize above-ground parts of toadflaxes. In fires where the roots of toadflaxes are not damaged, burning should not affect the larvae of *Rhinusa linariae*.

Grazing

Toadflaxes produce secondary compounds known to deter herbivory, which may make them initially less attractive for grazing. Horses, and grazing wildlife have been observed lightly browsing Dalmatian toadflax (Figure 85a), and cattle, domestic goats, and domestic sheep have been used successfully to suppress Dalmatian toadflax infestations (Figure 85b). Dalmatian toadflax provides adequate nutrition to livestock during targeted grazing; the animals feed on Dalmatian toadflax regularly and preferentially following a period of exposure. Grazing animals often avoid yellow toadflax, though deer and elk have been observed browsing flowering stems. Following prolonged exposure, cattle and sheep can be “trained” to graze yellow toadflax, which may help reduce seed production if animals are utilized short-term during flowering stages (Figure 85c); however, the effectiveness of using grazing to control yellow toadflax is largely unknown. The effect of grazing on hybrid toadflax has not been studied.

Grazing can exacerbate toadflax infestations. Livestock grazing can stimulate re-growth in grazed stems, and animals spread toadflax seeds that usually remain viable, even after ingestion. Overgrazing infested pastures reduces toadflax competition and increases soil disturbance, enhancing the establishment and spread of toadflax. Consequently, utilizing livestock for toadflax management must be done with caution, close observation, and only under the right circumstances.

Grazing the stems and flowers of toadflaxes would destroy populations of *Brachypterochus pulicarius*, *Calophasia lunula*, *Mecinus* spp., *Rhinusa antirrhini*, and *R. neta*. However, grazing that does not disturb the soil or roots of toadflaxes should not hinder the life cycle of the root-galling weevil, *Rhinusa linariae*. Biological control may be more compatible with responsible bison grazing because the bison diet consists primarily of grasses and, in general, less than 5% forbs.



Figure 85. Grazing toadflaxes a. deer grazing Dalmatian toadflax fruits; b. cattle grazing late-season Dalmatian toadflax (a,b Sharlene E. Sing, USDA FS RMRS), c. cattle-grazed yellow toadflax outside of exclusion cage and yellow toadflax still growing within exclusion cage. Trampled area surrounding cage is a result of cattle utilizing the cage panels for rubbing/scratching (Jessica Richert, The Nature Conservancy)

Seeding competitive species

Yellow toadflax is an economically important weed in crops such as mint, canola, barley, wheat, and strawberries. In this setting, planting the affected crops at high densities, using high quality seed/transplants, and planting crop species or varieties well adapted to local environmental conditions are all helpful for reducing yellow toadflax infestations. Tilling and/or applying selective herbicides and fertilizer to infested fields prior to planting enhances crop competitiveness and can increase yellow toadflax control.

In natural settings where toadflaxes are established and then suppressed by one or more control methods, reinvasion by toadflaxes or other undesirable species is likely if the ecological niche they occupied remains unfilled. Successful long-term management requires taking active measures to enhance the establishment and maintenance of desirable competitive species to avoid reinvasions.

Toadflax seedlings are sensitive to competition for light, moisture, and soil nutrients. Studies have shown that seeding with various exotic and native species can successfully reduce toadflax establishment while also proving beneficial to wildlife. The most suitable plant species to use for competition with toadflaxes depends on habitat, site conditions, climate, management goals, and future land use. Ideally, planted seeds should contain a mix of species, some of which should be quick to germinate and others to provide more long-term competition to toadflax seedlings. Utilizing ecologically equivalent species (those with root and growth patterns similar to toadflaxes) may provide the best competition. Inventorying nearby sites that are uninvaded by toadflaxes may provide insight into the best replacement species. Consult your local county extension agent or Natural Resource Conservation Service (NRCS) representative for additional help in determining the best alternatives in your area. Further suggestions for ecoregions throughout the United States may be found on the Native Seed Network website (please see Chapter 5 References for the URL). Likewise, the “links” section of the USDA PLANTS website offers numerous revegetation guideline manuals specific to different regions of both the United States and Canada. The USDA PLANTS site also provides access to a program and fact sheets that utilize soil, plant, and climate data to select plant species that

are site-specifically adapted, suitable for the selected practice, and appropriate for the goals and objectives of the revegetation project.

Control of toadflaxes prior to seeding more desirable species is important because established toadflax plants are highly competitive. Seeding of competitors should take place immediately following exposure of soil to maximize their competitive abilities (Figure 86). For example, seeding should occur in bare soil following burning or after young toadflax plants have been hand pulled or killed with herbicides. Because high populations of rodents can reduce the success of re-seeding, erecting a raptor perch/pole may discourage rodent habitation and help ensure seeded species successfully germinate and establish.

Incorporating biocontrol agents with re-seeding has not been studied explicitly for toadflaxes, but could be difficult, primarily because the methods used to establish a productive stand of competitive species are not always compatible with the establishment and survival of biological control agents. Any method used to initially reduce toadflax stems and foliage to promote the growth of competitive species would hinder the survival of *Brachypterolus pulicarius*, *Calophasia lumula*,



Figure 86. Revegetation efforts following soil disturbance (Lassen Volcanic National Park)

Eteobalea spp. *Mecinus* spp., *Rhinusa antirrhini*, and *R. neta*. Consequently, many successful revegetation programs establish competitive plant species first, using biological control agents after the seeded species have become established and toadflaxes begin to reappear. Alternatively, revegetation projects can target only a small portion of the infestation annually, leaving a reservoir of toadflax plants to support biocontrol agent populations. In some settings, it may be the biological control agents that open up the competing plant canopy, allowing for subsequent re-seeding to occur.

Chemical Control

Many herbicides are registered for use against toadflaxes growing in a variety of locations. Herbicide usage is most effective on small infestations, including newly established populations and recently established satellite patches arising from nearby older, larger toadflax infestations. If utilized appropriately, herbicides may also be useful on the leading edge of large, advancing toadflax infestations.

Herbicides may be too costly to be of practical use in treating extensive infestations of toadflaxes and, similar to physical and cultural control methods, are also impractical in hard-to-access and environmentally sensitive areas. Repeated herbicide applications may be required over time as toadflax plants can re-sprout from their root system if not completely killed, and new toadflax plants may germinate from the seedbank. Potential nontarget damage to associated vegetation must also be considered when using herbicides. For these reasons, herbicides are best used as part of a larger, integrated weed management program that employs other weed control methods in areas where herbicides are less likely to be cost effective or the most appropriate control choice.

Herbicides are generally applied in one of two ways: spot or broadcast applications. Spot treatments are used for individual toadflax plants or small patches. In spot applications, an appropriate herbicide is applied to the foliage of target plants only, thus reducing nontarget effects (Figure 87a,b). Broadcast treatments spray an appropriate herbicide over an entire area to treat larger weed infestations. Broadcast treatments should be used with caution as many herbicides also impact plants that land managers may want to retain. If a broadcast treatment should kill all plants in a treated area, the bare soil remaining often allows the toadflaxes to reinvade from the seedbank, creating a larger infestation than was there originally. Selective herbicides are those that target selected species (e.g. broad-leaved forbs vs. grasses) while leaving other species virtually unharmed. Utilizing selective herbicides in spot treatments helps reduce the nontarget impacts of herbicide applications, and is the recommended approach for treating toadflax infestations with chemical control. The herbicide label should always be referenced to help determine the chance of nontarget species damage.

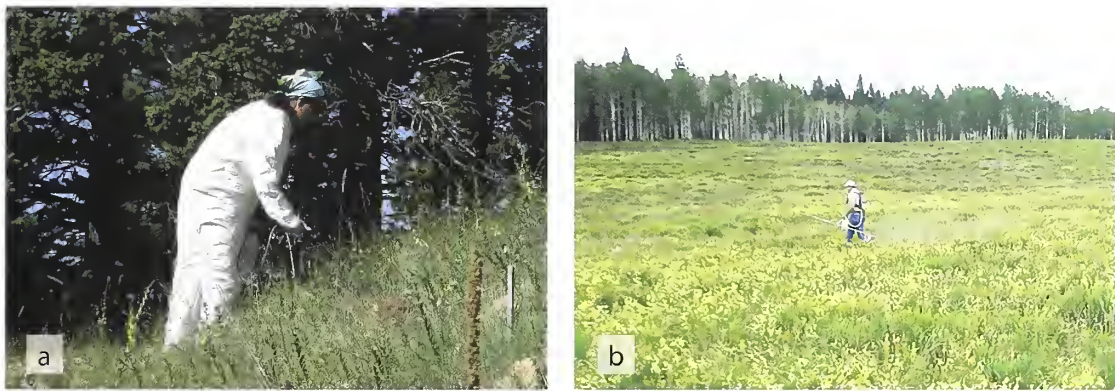

Figure 87. Applying herbicides a. Dalmatian toadflax (Sharlene E. Sing, USDA FS RMRS); b. yellow toadflax (Hal Pearce, USDA FS)

The optimal timing for herbicide application depends on site-specific variables including the stage of the toadflax plants and the climatic conditions present at the site. For example, chemical control of Dalmatian toadflax in California is most effective when treated plants receive adequate seasonal rainfall and are in the post-senescence or early rosette stage, as opposed to the early flowering stage for Great Plains and Intermountain West plants. Most herbicides currently registered for use against yellow toadflax work best when applied during flowering or in fall. For Dalmatian toadflax, treatments are most effective using picloram at full flower, and using chlorsulfuron in the spring or fall when applied to emerging rosettes (prior to bolting). The thick surfaces of leaves on Dalmatian toadflax hinder the uptake of herbicides, so adding a surfactant to the herbicide mix is highly recommended. Recent research has shown that a methylated seed oil/silicone blend surfactant works much better than the standard non-ionic surfactant. In general, yellow toadflax has been found less responsive to herbicide treatments than Dalmatian toadflax; higher application rates are often required when treating yellow toadflax. For both species, repeat applications and careful attention to the timing of application are required. The efficacy of herbicide compounds, application rates, and timing are not currently known for hybrid toadflax, though are likely to vary depending on the genetic composition of the population.

Some of the most widely used herbicides to combat toadflaxes in North America include:

- Chlorsulfuron application recommendations for Dalmatian toadflax vary depending on location; the majority state either bud-bloom stages or in fall when plants become dormant. The best success against yellow toadflax (up to 98% control for two years post-application) has been achieved when chlorsulfuron was applied during late summer or early fall when most of the shoots had already flowered so that adventitious root bud activity had begun. The highest rates of application are necessary in order to achieve the greatest success against both toadflax species, though these rates interfere with grazing restrictions on the label. Chlorsulfuron should be mixed with a surfactant to increase weed control results. A methylated seed oil/silicone blend surfactant is recommended. **This herbicide is selective against broadleaf species, but can also affect some grasses at certain application rates, so limiting its use should be considered when used in conjunction with some revegetation efforts.**
- Picloram has been applied more frequently than any other herbicide against Dalmatian or yellow toadflax, except where prohibited by proximity to water. It has proven effective against Dalmatian toadflax when applied during full flowering or in early fall. Picloram alone provides short-term control of yellow toadflax when applied during flowering or in fall. Because yellow toadflax can reportedly recover from single applications of picloram, repeated annual applications are recommended for three consecutive years to achieve lasting results. Control of yellow toadflax increases dramatically if picloram is combined with diflufenzopyr and dicamba. Picloram has a long soil residual period, which will reduce re-growth from Dalmatian and yellow toadflax roots or seedlings for 2-3 years post-application. Picloram is less useful in hot, sunny conditions or in sandy soil because it is degraded by sunlight and can leach below the root zone in sandy soils. **This herbicide is safe to use over established grasses, however young monocots may be affected. It will kill desirable legume species, and may kill other desirable broadleaf plants.**
- Imazapic is reportedly effective against both Dalmatian and yellow toadflax, though one study found it be somewhat ineffective against Dalmatian toadflax. Imazapic gives the best results when applied (along with a surfactant) to Dalmatian and yellow toadflax in fall, after a hard frost. **This herbicide is selective against broadleaf species, but can also target some grasses depending on application rates, so its use should be limited when used in conjunction with some revegetation efforts. In particular, cool-season grasses such as bluegrass and smooth brome are injured when imazapic is applied at high rates. Always follow label recommendations regarding re-planting intervals when using Imazapic.**
- Imazapyr is reportedly best applied to Dalmatian and yellow toadflax anytime plants are growing rapidly/actively. However, one study in California found excellent control was only achieved when imazapyr was applied in mid-fall to dormant plants. **It is a non-selective herbicide and should only be used in spot treatments and in situations where loss of nontarget vegetation is acceptable.** It is soil-active with a long residual activity, so is effective against preventing seedling germination. **However, it can harm other plants rooted in the general area or even downhill and can interfere with revegetation efforts.**
- Dicamba should be applied to actively growing Dalmatian and yellow toadflax rosettes in spring; effectiveness decreases once plants bolt or are dormant. Dicamba alone is usually not very effective herbicide against toadflaxes because although it can kill above-ground

growth, plants re-sprout from the roots, and repeated applications are required. However, there is some residual activity of dicamba that is useful against the seedbank. Dicamba is often mixed with other herbicides (especially picloram and diflufenzopyr) to increase weed control results. When mixed with diflufenzopyr, dicamba is accumulated in the plant and is more effective against the root system. **Dicamba will likely kill desirable broadleaf species, including legumes.** Alone, it does not kill grasses, sedges, cattails or other monocots (though increased effects may be observed when it is used in combination with diflufenzopyr).

- 2,4-D can be applied to Dalmatian and yellow toadflax rosettes or bolting plants in spring in conjunction with other broadleaf herbicides to increase their efficacy or help provide short-term control at lower application rates. 2,4-D, alone, will not harm grasses, sedges, cattails, or other monocots. However, 2,4-D alone is not the most effective herbicide against toadflaxes as there is no soil activity, and though above-ground growth may be killed, plants will re-sprout from the roots and from the soil seedbank. Repeated applications are required. 2,4-D has a low cost, so is often combined with other herbicides that offer more complete and/or residual control, such as picloram or chlorsulfuron.
- Glyphosate is typically applied to Dalmatian and yellow toadflax in spring during the actively growing rosette or bolting stages. It has had variable results against toadflaxes. It has no residual activity in the soil, and repeated applications are often required. **It is a non-selective herbicide and will create bare ground. It should only be used in spot treatments and in situations where loss of nontarget vegetation is acceptable.** Glyphosate use should be accompanied by revegetation of desirable species.
- Aminocyclopyrachlor is a relatively new herbicide that can provide excellent control of toadflaxes (especially Dalmatian) when applied at the beginning of flowering. Aminocyclopyrachlor applied to post-flowering yellow toadflax showed no impact, likely due to the senescing plants not translocating the herbicide. Studies in Colorado have shown potential in the control of yellow toadflax, especially when combined with chlorsulfuron. Aminocyclopyrachlor is currently available for use in non-crop areas, and may have a range and pasture label in the near future. It is available as a stand-alone herbicide, and is also sold pre-mixed with both chlorsulfuron and metsulfuron methyl. **Caution should be utilized with this compound as aminocyclopyrachlor can cause severe damage to nontarget plants, including trees, shrubs, many broadleaf species, and some grasses.**

When herbicides are used against toadflaxes, it is important that the applicator adhere to all label instructions to ensure the usage, surfactant requirement, application rate, application timing and location/site of herbicide application fall within label recommendations. Not all herbicides are registered for use against toadflaxes in all settings (including on or near water), or for use in each state of the USA and in Canada. Some herbicides are restricted use and can only be applied by a certified and licensed applicator, and then only under specific conditions. Herbicide treatments can vary widely depending upon geographic location, climatic conditions and rate of application. Please consult your local weed control authority, county agricultural extension agent, or forest invasive coordinator to learn which herbicides work best for toadflaxes control and when to apply them in your area.

If land usage of treated areas includes grazing practices, consult the herbicide label for any

grazing restrictions that might be applicable.

Heavy herbicide use will reduce the toadflax stems, leaves, and flowers on which *Brachypterolus pulicarius*, *Calophasia lunula*, *Mecinus* spp., *Rhinusa antirrhini*, and *R. neta* rely, thus hindering establishment of these species. Herbicides which kill toadflax root systems in addition to above-ground growth will likewise hinder the establishment of *Rhinusa linariae*. One way to successfully combine these two methods is to release biological control agents in a large, main infestation while applying herbicides to control small, satellite patches surrounding the main toadflax infestation.

The advantages and disadvantages of the most common toadflax control methods are summarized in Table 10.

Use Herbicides Safely!

Read the herbicide label, even if you have used the herbicide before. Follow all instructions on the label.

Wear protective clothing and safety devices as recommended on the label.

Bathe or shower after each herbicide application.

Be cautious when you apply herbicides. Know your legal responsibility as an herbicide applicator. You may be liable for injury or damage resulting from herbicide use.

Follow all storage and disposal instructions on the herbicide label.

Table 10. Comparison of toadflax management options.

CONTROL METHOD	ADVANTAGE	DISADVANTAGE	COMPATIBILITY WITH BIOCONTROL
Biological Control	Selective	Measurable changes in weed densities may take many years (eradication is not the goal)	Competition between <i>Rhinusa antirrhini</i> and <i>Brachypterosus pullicarius</i> prevents additive impact in many locations. Heavy feeding by <i>Mecinus</i> spp. suppresses flowering, which decreases the food source of <i>R. antirrhini</i> and <i>B. pullicarius</i>
	sustainable - agents generally do not have to be reintroduced once established	Some risk of undesirable effects on nontarget plants	
	Public acceptance is generally higher than with other weed control methods	Permanent; cannot be undone	
	Most economical option for large infestations	Not successful in all situations	
Physical Control (hand pulling)	Useful for small infestations that must be quickly eradicated	Must be repeated regularly due to constant threat of re-establishment from seedbank or plants re-growing from root fragments	applicable only to very small infestations where biocontrol is not recommended. Hand pulling is not directly compatible with any biocontrol agent; however, biocontrol can be applied to large, main infestations while hand pulling can be used on surrounding small, satellite populations
	Reduces seed production	Expensive and time intensive	
Physical Control (mowing)	Repeated mowing may reduce seed production; leaf removal reducing photosynthesis impedes root carbohydrate storage essential for plant persistence and vigor	May spread toadflaxes if done during flowering or seeding; can spur compensatory growth; toadflax can set seed below blade Expensive and time intensive; requires proper timing and equipment	Not compatible with <i>Brachypterosus pullicarius</i> , <i>Calophasia lunula</i> , <i>Mecinus</i> spp., <i>Rhinusa antirrhini</i> , and <i>R. ueta</i> . Mowing is more compatible with larval and pupal stages of the root-galling weevil <i>R. linearia</i> .
Physical Control (tilling)	Can kill toadflax plants when done repeatedly over a single growing season	Only applicable in limited crop settings May spread toadflaxes if done infrequently Expensive and time intensive; requires proper timing and equipment	Not compatible with all established toadflax biocontrol species. Tilling is only suitable in certain crop settings, where biocontrol is not recommended in general.

Table 10. Comparison of toadflax management options

CONTROL METHOD	ADVANTAGE	DISADVANTAGE	COMPATIBILITY WITH BIOCONTROL
Cultural Control (grazing)	Allows use of the land even with heavy toadflax infestations	Cannot be used in many natural areas such as national parks and wilderness areas	Grazing toadflax stems and flowers would destroy <i>Brachypterolus pullicarius</i> , <i>Calophastia lunula</i> , <i>Mecinus</i> spp., <i>Rhinusa antirrhini</i> , and <i>R. neta</i> . Grazing may be compatible with <i>R. linariae</i> if toadflax roots are not trampled/damaged. Compatible with bison grazing.
	Can be used (under the right conditions) in combination with chemical control methods	Non-selective; can exacerbate the problem	
	Can be used to restore native species	Can be expensive Kills only above-ground growth; toadflaxes can recover post grazing Expensive for large areas	Compatible if biocontrol agents are introduced after competitive species are established. Also compatible if re-seeding is done only on small sections of the infestation annually, leaving toadflax "refuges" for the biocontrol agents. In some settings, it is biocontrol that may make re-seeding feasible.
Cultural Control (re-seeding)	Can be self-perpetuating	May be ineffective if existing toadflax stands are dense	
Chemical Control	Fast acting	Expensive for large areas; repeat applications and monitoring often required	Herbicides are applicable only to small infestations, which are unsuitable for biocontrol. Compatible when using biocontrol on a main infestation and herbicides on surrounding small, satellite infestations.
	Successful in reducing toadflax individuals in some settings, especially in combinations with other control methods.	May harm desirable, culturally sensitive or protected plant species	Herbicides that kill only above-ground growth may be safe for use with <i>Rhinusa linariae</i> , though they interfere with the food source of <i>Brachypterolus pullicarius</i> , <i>Calophastia lunula</i> , <i>Mecinus</i> spp., <i>Rhinusa antirrhini</i> , and <i>R. neta</i> .
	If applied correctly and repeatedly, has the potential to eradicate some populations of toadflax	Often ineffective on yellow toadflax; highly dependent on applying an effective herbicide at the correct time in the growing season	
	Useful along transportation vectors (roads, trails, and occasionally waterways)	Public resistance to chemical controls Regulations or policies may prohibit us in some areas.	

GLOSSARY

abdomen	The last of the three insect body regions; usually containing the digestive and reproductive organs
adventive	Species that arrived in the geographical area from elsewhere by any means, but is not self-sustaining and whose numbers are only increased through non-reproductive means, unlike a naturalized species
alternate	Where leaves appear singly at stem nodes, on alternate side of the stem
annual	A plant that germinates, flowers, and dies all in the same year
antenna (pl. antennae)	In arthropods, one of a pair of appendages on the head, normally many jointed and of sensory function
aspirator	An apparatus used to suck insects into a collection container. The device can be simple (as in a mouth-aspirator) or mechanical (as in gasoline- or battery-powered vacuum aspirator)
basal	Located at the base of a plant or plant part
biennial	A plant that flowers and dies between its first and second years and does not flower in its first year
biological control	The reduction in abundance of a pest through intentional use of its natural enemies (predators, parasitoids, and pathogens)
biotype	An informal subdivision of a species; generally, refers to a group of organisms that are morphologically identical to other individuals of a species but possess distinctive physiological characteristics (e.g., able to attack a normally resistant host, or not susceptible to a pesticide)
bolting	Plant stage at which the flower stalk begins to develop
bract	A small, leaf-like structure below a flower
capsule (from plant)	A pod or seed vessel made of two or more cells, which becomes dry and splits open when mature to release its seeds (see “head capsule” for capsule from insect)
caterpillar	The larval stage of a moth or butterfly
chrysalis	The pupal stage of a moth or butterfly
cocoon	A silk case that moth or butterfly larvae spin to contain the chrysalis
community	A naturally-occurring group of different species of organisms that live together and interact as a more or less self-contained “unit”
complete metamorphosis	A life cycle with four distinct stages (egg, larva, pupa, adult)
compound eyes	Paired eyes consisting of many facets, or ommatidia, in most adult Arthropoda

coordinates	A set of numbers used to specify a location
defoliation	The loss of foliage due to insect or fungal activity or the actions of abiotic factors (e.g. hailstorms)
density	Number of individuals per unit area
dicot	Plant with two seed leaves upon germination, including most common flowering species, excluding grasses, sedges, cattails, lilies and orchids
dispersal	The spread of animals and plants from any point; the redistribution of plant seeds, fungal spores, or insect eggs, larvae, and adults
dissemination	Dispersal. Can be applied to seeds or insects
emergence (insect)	Act of adult insect leaving the pupal exoskeleton, or leaving winter or summer dormancy
elytron (pl. elytra)	Hardened forewing of a beetle
erect	Grows upright and vertical as opposed to prostrate (spreading on the ground)
exoskeleton	Hard, external skeleton of the body of an insect
exotic	Not native
field insectary	An area where host plants or animals are abundant and biological control agents are released and propagated with or without additional human manipulation
flower beetles	Small beetles in the family Kateretidae, the adults and larvae of which consume flowers and/or seeds of host plants
forb	Herbaceous plant (does not have solid woody stems)
frass	Plant fragments, usually mixed with excrement, deposited by feeding insects
gall	A plant tumor; a localized proliferation of abnormal plant tissue that is induced by an insect, nematode, fungus or other organism and usually exhibits a characteristic shape and color; gall-making insects usually live and feed within the gall
genus (pl. genera)	A taxonomic category ranking below family and above species and consisting of a group of species exhibiting similar characteristics. The genus name is followed by a Latin adjective or epithet to form the name of a species
GPS	Global Positioning System; a space-based navigational system providing location and time information by using four or more satellites
grub	A soft thick-bodied, C-shaped beetle larva
head	Insect segment with the mouth parts, antennae, and eyes

head capsule	Hardened covering of the head of an immature insect
herbivory	Feeding on plants
host	The plant or animal on which an organism feeds; the organism utilized by a parasitoid; a plant or animal susceptible to attack by a pathogen
host specificity	The highly-evolved, often obligatory association between an insect and its host (i.e. weed). A highly host-specific insect feeds only on its host and on no other species
hybrid	The offspring of two parent of different species
inflorescence	The flowering part of the plant
instar	The phase of an insect's nymphal or larval development between molts
larva (pl. larvae)	Immature insect stage between the egg and pupa (examples include grubs, caterpillars and maggots)
lateral root	Roots that extend horizontally from the primary root and serve to anchor the plant securely in the soil
litter	Dead plant material, such as leaves, bark, needles, twigs, that has fallen to the ground
margin (of leaf)	The edge of a leaf. Margins typically fall within a handful of categories and are useful in plant identification
membranous	Thin and transparent
metabolic sink	Any living cell, tissue, organ, or structure (e.g. gall) that is a storage depot of a metabolite
molting	Process of insect development
monocot	Plant with only one seed leaf upon germination, including grasses, sedges, cattails, lilies, and orchids
monoculture	An area vegetated by a single plant species
NAD 83	North American Datum, the official datum used for the UTM geographic coordinate system in North America
nectar	A sugar-containing secretion produced by plants, usually in flowers, that often attracts insect pollinators
node	Part of the stem of a plant from which a leaf, branch or root grows
nontarget effect	When control efforts affect a species other than the species they were enacted to control (can be positive or negative)
noxious weed	A weed whose control is mandated, and whose movement is regulated by federal or state law
oviposit	To lay or deposit eggs

perennial	A plant that lives for more than two years
petiole	Leaf stalk that attaches it to a plant stem
plant cover	The portion of the vegetative canopy in a fixed area attributable to an individual or a single plant species
pupa (pl. pupae v. pupate)	Non-feeding, inactive insect stage between larva and adult
qualitative	Measurement of descriptive elements (e.g. age class, distribution)
quantitative	Measurement of quantity; the number or amount (e.g. seeds per capitulum)
rhizome	A modified stem of a plant that grows horizontally underground, often sending out roots and shoots from its nodes
root crown	Part of a root system from which a stem arises
rosette	A compact, circular, and normally basal cluster of leaves
senescence	Final stage in a plant's life cycle when seeds are produced and plants die back
semi-gall	Plant tissue produced as an irritation response to the presence of egg-laying fluids, eggs, larvae, or larval frass. Different from true galls, they appear externally to be smaller swellings on plant stems
snout	The prolongation of the head of a weevil
species	A fundamental category of taxonomic classification, ranking below a genus or subgenus and consisting of related organisms capable of interbreeding
surfactant	Often applied with an herbicide mix to help bring the herbicide into closer contact with the leaf surface in order to aid absorption
synchrony	The classification of organisms in an ordered system that indicates natural relationships. The science, laws, or principles of classification; systematics
thorax	Body region of an insect behind the head and abdomen, bearing the legs and wings
transect	A straight line of varying length along which plants are periodically sampled individually or in quadrants
UTM	Universal Transverse Mercator, a grid-based geographic coordinate system
vegetative reproduction	Reproduction in plants other than by seeds, such as from rhizomes, stolons, and from nodes on lateral, often creeping roots
viability	The proportion of propagules (e.g. seeds) that are alive and can germinate

weevil	A type of plant eating beetle, the adults having distinct snouts of variable lengths
WGS 84	The World Geodetic System, a datum for latitude/longitude geographic coordinate systems

SELECTED REFERENCES

CHAPTER 1: INTRODUCTION

- Balciunas, J.K. 1999. Code of best practices for classical biocontrol of weeds. In: N.R. Spencer (ed.). Proceedings of the X International Symposium on Biological Control of Weeds. Montana State University, Bozeman, Montana, USA.
- Center for Invasive Species Management. 2015. State and Province Noxious Weed Lists. [No longer updated] (<http://www.weedcenter.org/resources/state.html>, Accessed 15 August 2015).
- Coombs, E.M., J.K. Clark, G.L. Piper, and A.F. Cofrancesco, Jr. (eds.). 2004. Biological Control of Invasive Plants in the United States. Oregon State University Press, Corvallis. 467 pp.
- EDDMapS. 2015. Early Detection & Distribution Mapping System. The University of Georgia - Center for Invasive Species and Ecosystem Health. (www.eddmaps.org, Accessed 15 August 2015).
- De Clerck-Floate, R.A. and A. McClay. 2013. *Linaria vulgaris* Mill., yellow toadflax (Plantaginaceae). In P.G. Mason and D. Gillespie, Eds. Biological Control Programmes in Canada 2001-2012. Chapter 53. CABI Publishing Wallingford, U.K. pp. 354–362.
- De Clerck-Floate, R.A. and S. Turner. 2013. *Linaria dalmatica* (L.) Mill., Dalmatian toadflax (Plantaginaceae). In P.G. Mason and D. Gillespie, Eds. Biological Control Programmes in Canada 2001–2012. Chapter 52. CABI Publishing Wallingford, U.K. pp. 342–353.
- NAPPO RSMP NO.7. 2008. North American Plant Protection Organization, Regional Standards for Phytosanitary Measures, Number 7. Guidelines for Petition for First Release of Non-indigenous Phytophagous Biological Control Agents. Ottawa, Ontario, Canada.
- Preston, R.E. and M. Wetherwax. 2011. *L. dalmatica* (L.) Mill, subsp. *dalmatica*, Dalmatian toadflax. In Jepson Flora Project. Jepson eFlora, http://ucjeps.berkeley.edu/cgi-bin/get_IJM.pl?tid=51304. 20 August 2015.
- Rice, P.M. 2015. INVADERS Database System (<http://invader.dbs.umt.edu>). Division of Biological Sciences, University of Montana, Missoula, MT 59812-4824. Accessed 15 August 2015.
- USDA, APHIS. 2016. Technical Advisory Group for Biological Control Agents of Weeds Manual - Interim Edition. Animal and Plant Health Inspection Service, Plant Protection and Quarantine. https://www.aphis.usda.gov/import_export/plants/manuals/domestic/downloads/tag-bcaw_manual.pdf
- USDA, ARS. 2015. National Genetic Resources Program. Germplasm Resources Information Network - (GRIN). Online Database. (<http://www.ars-grin.gov/4/cgi-bin/npgs/html/taxon.pl?102284>; 20 August 2015). National Germplasm Resources Laboratory, Beltsville, Maryland, USA.
- USDA, NRCS. 2015. The PLANTS Database (<http://plants.usda.gov>, 15 August 2015). National Plant Data Center, Baton Rouge, LA 70874-4490 USA.

- Winston, R.L., C.B. Randall, R. De Clerck-Floate, A. McClay, J. Andreas, and M. Schwarzländer. 2014. Field Guide for the Biological Control of Weeds in the Northwest. FHTET-2014-08. USDA Forest Service, Forest Health Technology Enterprise Team, Morgantown, West Virginia. 168 pp.
- Winston, R.L., M. Schwarzländer, H.L. Hinz, M.D. Day, M.J.W. Cock and M.H. Julien, Eds. 2014. Biological Control of Weeds: A World Catalogue of Agents and Their Target Weeds, 5th edition. USDA Forest Service, Forest Health Technology Enterprise Team, Morgantown, West Virginia. FHTET-2014-04. 838 pp.

CHAPTER 2: GETTING TO KNOW TOADFLAXES

- Albach, D.C., H.M. Meudt and B. Oxelman. 2005. Piecing together the “new” Plantaginaceae. *American Journal of Botany* 92: 297–315.
- Alex, J.F. 1962. The taxonomy, history, and distribution of *Linaria dalmatica*. *Can. J. Bot.* 40: 295–307.
- Arnold, R.M. 1982. Pollination, predation and seed set in *Linaria vulgaris* (Scrophulariaceae). *American Midland Naturalist* 107: 360–369.
- Bakshi, T.S. and R.T. Coupland. 1960. Vegetative propagation in *Linaria vulgaris*. *Canadian Journal of Botany* 38: 243–249.
- Carpenter, A. and T. Murray. 1998. Element stewardship abstract for *Linaria genistifolia* (L.) P. Miller ssp. *dalmatica* (L.) Maire & Petitmengin (synonym: *Linaria dalmatica* (L.) P. Miller) and *Linaria vulgaris* P. Miller: Dalmatian toadflax, broad-leaved toadflax and yellow toadflax, butter and eggs, wild snapdragon, common toadflax. The Nature Conservancy - wildland invasive species program. <http://tncweeds.ucdavis.edu/esadocs/documnts/linadal.html>
- Charlton, W.A. 1966. The root system of *Linaria vulgaris* Mill. I. Morphology and anatomy. *Canadian Journal of Botany* 44: 1111–1116.
- Charlton, W.A. 1967. The root system of *Linaria vulgaris* Mill. II. Differentiation of root types. *Canadian Journal of Botany* 45: 81–91.
- Chater, A.D., B. Valdés, and D.A. Webb. 1972. *Linaria* Miller. Pp. 226–236 in Tutin, T.G., V.H. Heywood, N.A. Burgess, S.M. Walters, and D.A. Webb (Eds.), *Flora Europaea* 3, Cambridge University Press, Cambridge.
- Coombs, E.M., J.K. Clark, G.L. Piper, and A.F. Cofrancesco, Jr. (eds.). 2004. *Biological Control of Invasive Plants in the United States*. Oregon State University Press, Corvallis. 467 pp.
- De Clerck-Floate, R.A. and A. McClay. 2013. *Linaria vulgaris* Mill., yellow toadflax (Plantaginaceae). In P.G. Mason and D. Gillespie, Eds. *Biological Control Programmes in Canada 2001–2012*. Chapter 53. CABI Publishing Wallingford, U.K. pp. 354–362.
- De Clerck-Floate, R.A. and S. Turner. 2013. *Linaria dalmatica* (L.) Mill., Dalmatian toadflax (Plantaginaceae). In P.G. Mason and D. Gillespie, Eds. *Biological Control Programmes in Canada 2001–2012*. Chapter 52. CABI Publishing Wallingford, U.K. pp. 342–353.
- Fernández-Mazuecos, M., J.L. Blanco-Pastor, and P. Vargas. 2013. A phylogeny of toadflaxes (*Linaria* Mill.) based on nuclear ITS sequences: systematic and evolutionary consequences. *International Journal of Plant Sciences* 174: 234–249.

- Grieshop, M.J., and R.M. Nowierski. 2002. Selected factors affecting seedling recruitment of Dalmatian toadflax. *J. Range Manage.* 55: 612–619.
- Macoun, W.T. 1908. List of herbaceous perennials tested in the arboretum and botanic garden, Central Experimental Farm, Ottawa, Canada with descriptions of flowers, and other notes. *Can. Bull.* 5, Second Series, Government Printing Bureau, Ottawa, ON Canada, p. 70.
- Nadeau, L.B., and J.R. King 1991. Seed dispersal and seedling establishment of *Linaria vulgaris* Mill. *Can. J. Plant Sci.* 71: 771–782.
- Niketić, M. and G. Tomović. 2008. Taxonomy and nomenclature of the *Linaria genistifolia* complex (Plantaginaceae-Antirrhineae) in S.E. Europe and Anatolia. *Taxon* 57: 619–629.
- Preston, R.E. and M. Wetherwax. 2011. *L. dalmatica* (L.) Mill, subsp. *dalmatica*, Dalmatian toadflax. In Jepson Flora Project. Jepson eFlora, http://ucjeps.berkeley.edu/cgi-bin/get_IJM.pl?tid=51304. 20 August 2015.
- Robocker, W.C. 1970. Seed characteristics and seedling emergence of Dalmatian toadflax. *Weed Sci.* 18: 720–725.
- Robocker, W.C. 1974. Life history, ecology, and control Dalmatian toadflax. *Wash. Agric. Exp. Sta. Tech. Bull.* 79. Wash. State Univ., Pullman.
- Robocker, W.C., R. Schirman, and B.A. Zamora 1972. Carbohydrate reserves in roots of Dalmatian toadflax. *Weed Sci.* 20: 212–214.
- Sutton, D.A. 1988. A Revision of the Tribe Antirrhineae. British Museum of Natural History, Oxford Univ. Press, London. 575 p.
- Toševski, I. 2013. (personal communication) CABI, Rue des Grillons 1, CH-2800 Delémont, Switzerland.
- Turner, M.F.S. 2012. Viability and invasive potential of hybrids between yellow toadflax (*Linaria vulgaris*) and Dalmatian toadflax (*Linaria dalmatica*). Ph.D. Dissertation, Colorado State University. Fort Collins, CO U.S.A.
- USDA, ARS. 2015. National Genetic Resources Program. Germplasm Resources Information Network - (GRIN). Online Database. (<http://www.ars-grin.gov/cgi-bin/npgs/html/taxon.pl?102284>; 20 August 2015). National Germplasm Resources Laboratory, Beltsville, Maryland, USA.
- USDA, NRCS. 2015. The PLANTS Database (<http://plants.usda.gov>, 15 August 2015). National Plant Data Center, Baton Rouge, LA 70874-4490 USA.
- Vujnovic, K. and R.W. Wein. 1997. The biology of Canadian weeds. 106. *Linaria dalmatica* (L.) Mill. *Canadian Journal of Plant Science* 77: 483–491.
- Ward, S.M., C.E. Fleischmann, M.F. Turner and S.E. Sing. 2009. Hybridization between invasive populations of Dalmatian toadflax (*Linaria dalmatica*) and yellow toadflax (*Linaria vulgaris*). *Invasive Plant Science and Management* 2(4): 369–378.
- Zouhar, K. 2003. *Linaria* spp. In: Fire Effects Information System, [Online]. U.S. Department of Agriculture, Forest Service, Rocky Mountain Research Station, Fire Sciences Laboratory (Producer). Available: <http://www.fs.fed.us/database/feis/> [15 August 2015].

CHAPTER 3: BIOLOGY OF TOADFLAXES BIOLOGICAL CONTROL AGENTS

- Andreas, J.E., E.M. Coombs, J. Milan, and M. Schwarzländer. 2014. Biological Control. In E. Peachey, Ed. Pacific Northwest Weed Management Handbook. Oregon State University, Corvallis, Oregon. pp. B1-B6.
- British Columbia Biocontrol Agent on Invasive Plant Matrix. 2015. British Columbia Ministry of Forests, Lands, and Natural Resources. (https://www.for.gov.bc.ca/hra/Plants/biocontrol/Agent-plant_matrix.htm, Accessed 04 July 2015).
- Caldara, R., D. Sassi, and I. Toševski. 2010. Phylogeny of the weevil genus *Rhinusa* Stephens based on adult morphological characters and host plant information (Coleoptera: Curculionidae). *Zootaxa* 2627: 39–56.
- Coombs, E.M., J.K. Clark, G.L. Piper, and A.F. Cofrancesco, Jr. (eds.). 2004. Biological Control of Invasive Plants in the United States. Oregon State University Press, Corvallis. 467 pp.
- De Clerck-Floate, R. A., and P. Harris. 2002. *Linaria dalmatica* (L.) Miller, Dalmatian toadflax (Scrophulariaceae), pp. 368–374. In P. G. Mason and J. T. Huber (eds.), Biological Control Programmes in Canada, 1981-2000. CABI Publishing, Wallingford, Oxon, UK.
- De Clerck-Floate, R.A. and A. McClay. 2013. *Linaria vulgaris* Mill., yellow toadflax (Plantaginaceae). In P.G. Mason and D. Gillespie, Eds. Biological Control Programmes in Canada 2001-2012. Chapter 53. CABI Publishing Wallingford, U.K. pp. 354–362.
- De Clerck-Floate, R., and V. Miller. 2002. Overwintering mortality of and host attack by the stem-boring weevil, *Mecinus janthinus* Germar, on Dalmatian toadflax (*Linaria dalmatica* (L.) Mill.) in western Canada. *Biol. Control* 24: 65–74.
- De Clerck-Floate, R.A. and S. Turner. 2013. *Linaria dalmatica* (L.) Mill., Dalmatian toadflax (Plantaginaceae). In P.G. Mason and D. Gillespie, Eds. Biological Control Programmes in Canada 2001-2012. Chapter 52. CABI Publishing Wallingford, U.K. pp. 342–353.
- Egan, J.F., and R.E. Irwin. 2008. Evaluation of the field impact of an adventitious herbivore on an invasive plant, yellow toadflax, in Colorado, USA. *Plant Ecology* 199: 99–114.
- Gassmann, A., R. De Clerck-Floate, S. Sing, I. Toševski, M. Mitrović and O. Krstić. 2014. Biology and host specificity of *Rhinusa pilosa*, a recommended biological control agent of *Linaria vulgaris*. *BioControl* 59: 473–483.
- Gassmann, A. and C. Paetel. 1998. *Gymnetron netum* (Col.; Curculionidae) A potential agent for biological control of toadflax in North America summary report 1996-1998. CABI Bioscience, Switzerland Centre, Delemont, Switzerland. 27p.
- Grubb, R.T., R.M. Nowierski, and R.L. Sheley. 2002. Effects of *Brachypterolus pulicarius* (L.) (Coleoptera: Nitidulidae) on growth and seed production of Dalmatian toadflax, *Linaria genistifolia* ssp. *dalmatica* (L.) Maire and Petitmengin (Scrophulariaceae). *Biol. Control* 23: 107–114.
- Hansen, R., T. Costanzo, and L. Morales. 2012. Rearing and field releases of the yellow toadflax stem-mining weevil, *Mecinus janthinus*. pp. 37-39 In USDA-APHIS-PPQ-CPHST, Fort Collins and Phoenix Laboratories 2012 Annual Report. 64 pp.

- Harris, P. 1963. Host specificity of *Calophasia lumula* (Hufn.) (Lepidoptera: Noctuidae). *Can. Entomol.* 95: 101–105.
- MacKinnon, D.K., R.A. Hufbauer, and A.P. Norton. 2007. Evaluating host use of an accidentally introduced herbivore on two invasive toadflaxes. *Biological Control* 41: 184–189.
- MacKinnon, D.K., R.A. Hufbauer, and A.P. Norton. 2005. Host-plant preference of *Brachypterolus pulicarius*, an inadvertently introduced biological control insect of toadflaxes. *Entomologica Experimentalis et Applicata* 116: 183–189.
- Malicky, H. 1967. Climatological and ecological aspects of the geographical distribution of the genus *Calophasia* Steph. (Lep., Noctuidae). *Technical Bulletin of the Commonwealth Institute of Biological Control* 8: 103–116.
- McClay, A.S., and R.A. De Clerck-Floate. 2002. *Linaria vulgaris* Miller, yellow toadflax (Scrophulariaceae), pp. 375–382. In P. G. Mason and J. T. Huber (eds.), *Biological Control Programmes in Canada, 1981–2000*. CABI Publishing, Wallingford, Oxon, UK. Rees, N.E., P.C. Quimby, Jr., G.L. Piper, E.M. Coombs, C.E. Turner, N.R. Spencer, L.V. Knutson. 1996. *Biological Control of Weeds in the West*. Western Society of Weed Science, Bozeman, Montana.
- McClay, A.S. and R.B. Hughes. 2007. Temperature and host-plant effects on development and population growth of *Mecinus janthinus* (Coleoptera: Curculionidae), a biological control agent for invasive *Linaria* spp. *Biol. Control.* 40: 405–410.
- Peterson, R.K.D., S.E. Sing, and D.K. Weaver. 2005. Differential physiological responses of Dalmatian toadflax, *Linaria dalmatica* (L.) Miller, to injury from two insect biological control agents: implications for decision-making in biological control. *Environmental Entomology* 34: 899–904.
- Saner, M.A. and Müller-Schärer, H. 1994. Impact of root mining by *Eteobalea* spp. on clonal growth and sexual reproduction of common toadflax, *Linaria vulgaris* Mill. *Weed Research* 34: 199–204.
- Saner, M.A., P. Jeanneret, and H. Müller-Schärer 1994. Interaction among two biological control agents and the developmental stage of their target weed, Dalmatian toadflax, *Linaria dalmatica* (L.) Mill. (Scrophulariaceae). *Biocontrol. Sci. Technol.* 4: 215–222.
- Toševski, I., R. Caldara, J. Jović, G. Hernández-Vera, C. Baviera, A. Gassmann, and B.C. Emerson. 2015. Host-associated genetic divergence and taxonomy in the *Rhimusa pilosa* Gyllenhal species complex: an integrative approach. *Systematic Entomology* 40: 268–287.
- Tosevski, I., A. Gassmann, M. Desančić and J. Jović. 2008. Biological control of Dalmatian and yellow toadflaxes, *L. dalmatica* and *L. vulgaris*. Annual Report 2007. Unpublished Report, CABI Europe – Switzerland, Delémont, Switzerland.
- Toševski, I., A. Gassmann, M. Desančić and J. Jović. 2010. Biological control of Dalmatian and yellow toadflaxes, *Linaria dalmatica* and *L. vulgaris*. Annual Report 2009. CABI Europe-Switzerland. CABI Ref.: VM00770B, April 2010. 31–99.
- Toševski, I., R. Caldara, J. Jovic, G. Hernández-Vera, C. Baviera, A. Gassmann, and B. Emerson. 2011. Morphological, molecular and biological evidence reveal two cryptic species in *Mecinus janthinus* Germar (Coleoptera, Curculionidae), a successful biological control

- agent of Dalmatian toadflax, *Linaria dalmatica* (Lamiales, Plantaginaceae). Systematic Entomology: 1–13.
- Turner, S.C. 2014. (personal communication) Ministry of Forests, Lands and Natural Resource Operations, Provincial Range Operations - Kamloops, 441 Columbia Street Kamloops, BC V2C 2T3.
- Van Hezewijk, B.H., R.S. Bouchier and R.A. De Clerck-Floate. 2010. Regional-scale impact of the weed biocontrol agent *Mecinus janthinus* on Dalmatian toadflax (*Linaria dalmatica*). Biological Control 55: 197–202.
- Volenberg, D.S., H.J. Hopen and D.L. Mahr. 1996. The rearing of the root mining larva *Eteobala serratella* Treitschke (Lep.: Cosmopterigidae) for control of *Linaria vulgaris* Mill. Weed Sci. Soc. Am. Abstract 36: 69.
- Winston, R.L., C.B. Randall., R. De Clerck-Floate, A. McClay, J. Andreas, and M. Schwarzländer. 2014. Field Guide for the Biological Control of Weeds in the Northwest. FHTET-2014-08. USDA Forest Service, Forest Health Technology Enterprise Team, Morgantown, West Virginia. 168 pp.
- Winston, R.L., M. Schwarzländer, H.L. Hinz, M.D. Day, M.J.W. Cock and M.H. Julien, Eds. 2014. Biological Control of Weeds: A World Catalogue of Agents and Their Target Weeds, 5th edition. USDA Forest Service, Forest Health Technology Enterprise Team, Morgantown, West Virginia. FHTET-2014-04. 838 pp.

CHAPTER 4: ELEMENTS OF A TOADFLAXES BIOCONTROL PROGRAM

- Coombs, E.M., J.K. Clark, G.L. Piper, and A.F. Cofrancesco, Jr. (eds.). 2004. Biological Control of Invasive Plants in the United States. Oregon State University Press, Corvallis. 467 pp.
- De Clerck-Floate, R., and K.W. Richards. 1997. Pollination ecology and biocontrol: developing release strategies for seed feeding insects on Dalmatian toadflax. Acta Hort. (Wageningen) 437: 379–384.
- Harris, P. 1984. *Linaria vulgaris* Miller, yellow toadflax and *L. dalmatica* (L.) Mill., broad-leaved toadflax (Scrophulariaceae). In: Kelleher, J.S. and M.A. Hulme (eds) Biological Control Programmes Against Insects and Weeds in Canada 1969-1980. Commonwealth Agricultural Bureaux, Slough, England. 179–182.
- Harris, P. and A.C. Carder. 1971. *Linaria vulgaris* Mill., yellow toadflax, and *Linaria dalmatica* (L.) Mill., broad-leaved toadflax (Scrophulariaceae). In: Biological Control Programmes in Canada, 1959-1968. Commonwealth Institute of Biological Control Technical Communication 4: 94–97.
- Loan, L.A. 1954. Progress report on a study of insects found on toadflax, *Linaria vulgaris* Mill., from Saskatchewan and Belleville, Ontario. Ent. Res. Inst. for Biol. Control, Belleville, Ontario.
- McClay, A.S., and R.A. De Clerck-Floate. 2002. *Linaria vulgaris* Miller, yellow toadflax (Scrophulariaceae), pp. 375-382. In P. G. Mason and J. T. Huber (eds.), Biological Control Programmes in Canada, 1981-2000. CABI Publishing, Wallingford, Oxon, UK.

- Nowierski, R.M. 1995. Dalmatian toadflax, pp. 312–317. In J.R. Nechols, L.A. Andres, J.W. Beardsley, R.D. Goeden, and C.G. Jackson (eds.), *Biological Control in the Western United States: Accomplishments and Benefits of Regional Research Project W-84, 1964-1989*. Univ. Calif. Div. Agric. Nat. Res. Publ. 3361, Oakland, CA.
- Rees, N.E., P.C. Quimby, Jr., G.L. Piper, E.M. Coombs, C.E. Turner, N.R. Spencer, and L.V. Knutson. 1996. *Biological Control of Weeds in the West*. Western Society of Weed Science, USDA/ARS, Montana Dept. Agric., Montana State Univ., Bozeman, MT.
- Sing, S.E., R.K.D. Peterson, D.K. Weaver, R.W. Hansen and G.P. Markin. 2005. A retrospective analysis of known and potential risks associated with exotic toadflax-feeding insects. *Biological Control* 35: 276–287.
- Turner, S.C. 2014. (personal communication) Ministry of Forests, Lands and Natural Resource Operations, Provincial Range Operations - Kamloops, 441 Columbia Street Kamloops, BC V2C 2T3.
- Winston, R.L., C.B. Randall., R. De Clerck-Floate, A. McClay, J. Andreas, and M. Schwarzländer. 2014. *Field Guide for the Biological Control of Weeds in the Northwest*. FHTET-2014-08. USDA Forest Service, Forest Health Technology Enterprise Team, Morgantown, West Virginia. 168 pp.

CHAPTER 5: AN INTEGRATED TOADFLAXES MANAGEMENT PROGRAM

- Almquist, T.L., K.L. Wirt, J.W. Adams, and R.G. Lym. 2015. Adaptive development of yellow toadflax (*Linaria vulgaris*) chemical control recommendations. *Invasive Plant Science and Management*: 8: 276–283.
- Baig, M.N., A.L. Darwent, K.N. Harker, J.T. O'Donovan. 1999. Preharvest applications of glyphosate for yellow toadflax (*Linaria vulgaris*) control. *Weed Technology* 13:777–782.
- Baig, M.N., K.N. Harker and A.L. Darwent. 1994. Tillage enhances yellow toadflax (*Linaria vulgaris* Mill.) control with glyphosate. *Weed Sci. Soc. Am. Abstract* 34:16.
- Beck, K.G. 2014. *Biology and Management of the Toadflaxes*. Fact Sheet No. 3.114. Colorado State University Extension. 4 pp.
- Burrows, G.E. and R.J. Tyrl. 2001. *Scrophulariaceae Juss.*, In: *Toxic Plants of North America*. Iowa State University Press. Ames IA. Pp 1092–1103.
- Davison, J.C., E. Smith, and L.M. Wilson. 2006. *Livestock grazing guidelines for controlling noxious weeds in the western United States*. UNR Cooperative Extension Publication EB-06-05. University of Nevada – Reno, Reno NV. 85 pp.
- DiTomaso, J.M., G.B. Kyser et al. 2013. *Weed Control in Natural Areas in the Western United States*. Weed Research and Information Center, University of California. 544 pp.
- Duncan, C.A., S.A. Dewey and M.B. Halstvedt. 1999. The effect of picloram and picloram plus 2,4-D on Dalmatian toadflax. *Proceedings of the Western Society Weed Science* 52:73–74.
- Dodge, R.S. and P.Z. Fulé. 2008. Dalmatian toadflax (*Linaria dalmatica*) response to wildfire in a southwestern USA forest. *Ecoscience* 15:213–222.

- Frost, R.A., L.M. Wilson, K.L. Launchbaugh, and E.M. Hoyde. 2008. Seasonal change in forage value of rangeland weeds in northern Idaho. *Invasive Plant Science and Management* 1:343–351.
- Gates, D.H., and W.C. Robocker. 1960. Revegetation with adapted grasses in competition with Dalmatian toadflax and St. Johnswort. *J. Range Manage.* 13: 322–326.
- Harker, K.N., J.T. O'Donovan and R.E. Blackshaw. 1995. Integrated management of yellow toadflax in a zero tillage system. Pp 79–82 In: G.P. Lafond, H.M. Plas, and E.G. Smith (Eds) *Bringing Conservation Technology to the Farm*. PARI Factbook. Proceedings of the Conservation Workshop, November 26-28, 1995. Saskatoon, SK.
- Jacobs, J.S. and R.L. Sheley. 2003a. Combination of burning and herbicides may favor establishment of weedy species in rangeland restoration (Montana). *Ecological Restoration* 21: 329–330.
- Jacobs, J.S. and R.L. Sheley. 2003b. Prescribed fire effects on Dalmatian toadflax. *Journal of Range Management* 56:193–197.
- Jacobs, J.S. and R.L. Sheley. 2003c. Testing the effects of herbicides and prescribed burning on Dalmatian toadflax (Montana). *Ecological Restoration* 21:138–139.
- Jacobs, J.S. and R.L. Sheley. 2005. The effect of season of picloram and chlorsulfuron application on Dalmatian toadflax (*Linaria genistifolia*) on prescribed burns. *Weed Technology* 19:319–324.
- Jacobs, J. and S. Sing. 2007. Ecology and Management of Yellow Toadflax (*Linaria vulgaris* (L.) Mill.). USDA, Natural Resources Conservation Service, Invasive Species Technical Note No. MT-7.
- Kadrmaz, T. and W.S. Johnson. 2002. Managing yellow and Dalmatian toadflax, Fact Sheet FS-09-96 UNR Cooperative Extension. University of Nevada – Reno, Reno NV. 4 pp.
- Kyser, G.B. and J.M. DiTomaso. 2013. Effect of timing on chemical control of Dalmatian toadflax (*Linaria dalmatica*) in California. *Invasive Plant Science and Management* 6:362–370.
- Lajeunesse, S. 1999. Dalmatian and yellow toadflax. Pp. 202–216 In: R.L. Sheley and J.K. Petroff [eds] *Biology and Management of Noxious Rangeland Weeds*. Oregon State University Press, Corvallis, OR
- Lajeunesse, S.E. P.K. Fay, D. Cooksey, J.R. Lacey, R.M. Nowierski, and D. Zamora D. 1993. Dalmatian and Yellow Toadflax: Weeds of Pasture and Rangeland. Montana State University Extension Service Publication EB 115. Bozeman MT.
- Lym, R.G. 2014. Comparison of aminocyclopyrachlor absorption and translocation in leafy spurge (*Euphorbia esula*) and yellow toadflax (*Linaria vulgaris*). *Weed Science* 62:321–325.
- Morishita, D.W. 1991. Dalmatian toadflax, yellow toadflax, black henbane, and tansymustard: importance, distribution, and control. Pp. 399–407 In: L.F. James, J.O. Evans, M.H. Ralphs, R.D. Childs (eds) *Noxious Range Weeds*. Westview Press, Boulder CO.
- Nadeau, L.B., M.R.T Dale, and J.R. King. 1991. The development of spatial pattern in shoots of *Linaria vulgaris* (Scrophulariaceae) growing on fallow land or in a barley crop. *Canadian Journal of Botany* 69: 2539–2544.

- Nadeau, L.B., J.R. King, and K.N. Harker. 1992. Comparison of growth of seedlings and plants grown from root pieces of yellow toadflax (*Linaria vulgaris*). *Weed Science* 40:43–47.
- Native Seed Network. <http://www.nativeseednetwork.org>. Accessed 22 August 2015.
- Olson, B and K. Launchbaugh. 2006. Managing herbaceous broadleaf weeds with targeted grazing. Pp 58–67 In: K.L. Launchbaugh (Ed). *Targeted Grazing: A Natural Approach to Vegetation Management and Landscape Enhancement*. American Sheep Industry Association. Cottrell Printing, Centennial CO.
- Pacific Northwest Weed Management Handbook. 2014. Compiled by E. Peachey, D. Ball, R. Parker, J.P. Yenish, T.W. Miller, D.W. Morishita, and P.J.S. Hutchinson. Oregon State University Agricultural, Corvallis, OR. 451 pp. <http://pnwhandbooks.org/weed/>
- Rose, K.K., T.D. Whitson, and D.W. Koch. 1999. The competitive effects of five cool-season grasses on Dalmatian toadflax (*Linaria genistifolia* ssp. *dalmatica*). *Proceedings of the Western Society of Weed Science* 52:64–67.
- Sing, S.E. and R.K.D. Peterson. 2011. Assessing environmental risks for established invasive weeds: Dalmatian (*Linaria dalmatica*) and yellow (*L. vulgaris*) toadflax in North America. *International Journal of Environmental Research and Public Health* 8:2828–2853.
- USDA, NRCS. 2015. The PLANTS Database (<http://plants.usda.gov>, 15 August 2015). National Plant Data Center, Baton Rouge, LA 70874-4490 USA.
- VanBebber, R. 2003. *CWMA Cookbook: A Recipe for Success*. Idaho State Department of Agriculture, Boise, ID. 22 pp.
- Zilke, S. and R.T. Coupland. 1954. The effect of one cultivation on the density of toadflax (*Linaria vulgaris* Hill). *Research Report of the National Weed Committee, Western Section*. p. 107.
- Zouhar, K. 2003. *Linaria* spp. In: *Fire Effects Information System*, [Online]. U.S. Department of Agriculture, Forest Service, Rocky Mountain Research Station, Fire Sciences Laboratory (Producer). Available: <http://www.fs.fed.us/database/feis/> [15 August 2015].

APPENDICES

APPENDIX I: TROUBLESHOOTING GUIDE: WHEN THINGS GO WRONG

PROBLEM	PROBABLE CAUSE	SOLUTION	
Biological control agents unhealthy or dead when received	Physical damage to agents in transport	Provide adequate packing material to minimize movement of containers and ice packs	
	Drowning	Do not put water in containers during transport; prevent accumulation of excess moisture; too much plant material causes condensation	
	Excess or prolonged heat or cold	Keep containers cool at all times; use coolers and ice packs; avoid exposure to direct sunlight while in transit	
	Starvation	Put toadflaxes foliage (no flowers, seeds or roots) in containers; minimize time agents are in containers	
	Release delay	Transport or ship agents immediately after collection	
			Release agents at new site immediately upon arrival or receipt of agent
Parasitism and/or disease	Check source agents. Ensure the insect population is disease-free when collecting or receiving shipment		
Reproductive problems	Agents past reproductive stage	Collect at peak activity (i. e. insects are mating and ovipositing)	
	Sex ratio: not enough males or females	Collect at peak activity; observing mating among target agents before collecting; males often emerge earlier than females	
	Agents not synchronized with the toadflax growth stage	Biological control agents require the weed to be at specific growth stage for optimal oviposition; collect agents from sites with plants in similar stages.	
Few biological control agents collected	Collection at wrong time	Refer to Table 8 for collection time and technique	
	Collection technique	Biological control agents can be killed/damaged during sweeping or aspirating so sweep lightly; avoid debris	
	Conditions at the time of collection wrong	Refer to Chapter 4 section "Collecting Toadflax Biological Control Agents" for guidelines on desirable weather conditions	
	Population insufficient	Only collect from well established populations	
Agents not found after release	Site is unsuitable or too small	Refer to Chapter 4 section "selecting Biological Control Agent Release Sites"	
	Not enough agents released	Release at least 200 adults of the toadflax beetle species and at least 100 <i>Calophasia lumula</i>	
	Pesticide use/mowing in area	Select sites where land usage and management practices will not interfere with biological control agent life cycles	
	Released on wrong species	Ensure toadflaxes and the correct biological control agent are used	
	Released at wrong time	Release only during the correct plant stage and in the cool hours of the day. Refer to Table 8 for guidelines	
	Agents not well adapted to conditions	Release field-collected biocontrol agents from local sources wherever possible rather than greenhouse-reared adults or insects collected from distant locations	
	Ants or other predators preyed upon biocontrol agents	Release only at sites with no obvious ant mound or high insect predator populations (e. g. mice, voles)	
Cannot locate release site	Location marker not obvious	Use bright-colored wooden, metal or plastic stake	
	Site destroyed	Communicate with all direct and neighboring land users	
	Map poorly/incorrectly drawn	Check map; redraw with more detail or add landmarks; GPS	

APPENDIX II: SAMPLE BIOLOGICAL CONTROL AGENT RELEASE FORM

Released By: _____ Release Date: ___/___/___ State: _____ County: _____
 (mm dd yy)

Biocontrol Agent: _____ # Released: _____

Source of Agents: _____ Date Collected: ___/___/___
 (mm dd yy)

Life Stage (circle): Larvae Adults

Land Ownership (circle): Private County State USFS BLM COE BOR BIA/Tribe TNC Other (specify) _____

Legal: T ___ R ___ Sec ___ Q ___ Lat: Deg ___ Min ___ Sec ___ Long: Deg ___ Min ___ Sec ___

UTM: UTM Datum Zone: ___ UTM Year: ___ UTM Easting: _____ UTM Northing: _____

ENVIRONMENT

Temperature (°F): _____ Wind: Calm, Light, Moderate, Strong, Gusty Wind Direction: N S E W

Weather (circle): Clear Ptlly Cloudy Cloudy Rain Snow Release Time: _____ AM/PM

Site Aspect (circle): N, NE, E, SE, S, SW, W, NW Elevation: _____

Site Slope: Flat (0-10%) _____ Gentle (10-30%) _____ Moderate (30-60%) _____ Steep (>60%) _____

Topographic Position (circle): Valley Bottom Terrace Lower Slope Mid/Upper Slope Crest

Disturbance: (check all that apply, circle most prevalent) Cultivation ___ Fire ___ Flood ___ Grazing ___ Logging ___
 Roads ___ Mining ___ Recreation ___

SITE CHARACTERISTICS

Site Name: _____ Size of Infestation (acres): _____ Estimated % Weed Cover: _____

Est. Weed Height (cm): _____ Est. Weed Density (# per meter sq.): _____ Dominant Plant: _____

Distribution of Weed: Isolated ___ Scattered ___ Sc-Patchy ___ Patchy ___ Continuous ___ Linear ___

Phenology: Seedling % ___ Rosette % ___ Bolt % ___ Bud % ___ Flowering % ___ Seed % ___ Dormant % ___

Vegetation Type (check):	Estimate % Cover:
Grassland <input type="checkbox"/>	Tree _____
Pasture <input type="checkbox"/>	Shrub _____
Dry Meadow <input type="checkbox"/>	Forb _____
Moist Meadow <input type="checkbox"/>	Grass _____
Shrubland Steppe <input type="checkbox"/>	Litter _____
Conifer Forest <input type="checkbox"/>	Bare Ground _____
	Rock _____

Soil Texture: (check) Sand ___ Silt ___ Clay ___ Gravel ___ Loam ___

APPENDIX II: SAMPLE BIOLOGICAL CONTROL AGENT RELEASE FORM (SIDE 2)

CONTACT PERSON:

Name: _____
Address: _____
City: _____
State: _____
Phone: _____ - _____ - _____
e-mail: _____

LEGAL LANDOWNER:

Name: _____
Address: _____
City: _____
State: _____
Phone: _____ - _____ - _____
e-mail: _____

Road Map to Site

Site and Vegetation Map

Comments:

APPENDIX III: STANDARDIZED IMPACT MONITORING PROTOCOL (SIMP)

Please see the following site for more information and downloadable forms:

http://www.agri.idaho.gov/AGRI/Categories/PlantsInsects/NoxiousWeeds/Bio_Control.php

Idaho's Statewide Monitoring Guidelines for *Mecinus janthinus* and Dalmatian Toadflax:



Overview:

A critical part of successful weed biological control programs is a monitoring process to measure populations of biological control agents and the impact that they are having on the target weed. Monitoring should be conducted on an annual basis for a number of years. The Idaho State Department of Agriculture, in conjunction with the University of Idaho, Nez Perce Biocontrol Center, and federal land management agencies, has developed the monitoring protocol below to enable land managers to take a more active role in monitoring the progress and weed control ability of the toadflax stem-mining weevil, *Mecinus janthinus* (MEJA) in efforts to control Dalmatian toadflax, *Linaria genistifolia* ssp. *dalmatica*. This monitoring protocol was designed to be implemented by land managers in a timely manner while providing data which will enable researchers to better quantify the impact of URCA on Canada thistle throughout the state.

Dalmatian Toadflax:

Dalmatian toadflax is a perennial that grows up to 4 feet tall. Its waxy green leaves are heart shaped, 1 to 3 inches long, and clasp the stem. Flowers are 1 inch long (excluding the 1/2-inch spur), yellow, often tinged with orange or red, and similar in shape to a snapdragon. Plants flower from midsummer to fall. Seeds are produced in a 1/2-inch pod and are irregularly wing angled. A single plant may produce up to 500,000 seeds in a season which may remain viable in the soil for up to 10 years. This plant also reproduces vegetatively by stems that develop from adventitious buds on primary and creeping lateral roots. It is usually associated with sparsely vegetated areas, such as roadsides, abandoned or unmanaged land, gravel pits, and disturbed pastures and rangelands. It is found in most counties in Idaho. This invasive plant and other *Linaria* species are reportedly toxic to livestock.



Toadflax Stem-Mining Weevil (MEJA):

Adult MEJA are small, somewhat elongated bluish black weevils which emerge from last year's infested Dalmatian toadflax stems in April-May. Adult MEJA feed on toadflax stems that are at least 0.04 inches in diameter and feed on leaves and stems from June to mid-July before mating and laying eggs inside new shoots. The eggs typically hatch in 6-7 days. Larvae tunnel within the toadflax stem for 23 to 34 days moving no more than 1.2 inches from where the egg was laid. Pupation occurs within the stem. Adult feeding on stems and leaves has a limited impact on the

APPENDIX III: STANDARDIZED IMPACT MONITORING PROTOCOL (SIMP) (CONT.)

plant. Larval mining impacts the plants by causing premature wilting of shoots and suppressing flower formation. MEJA overwinter as adults inside their pupation chamber. The effects of the weevil on the plant are reportedly enhanced under drought stress.

Monitoring:

The Statewide Biological Control monitoring protocol is based upon a permanent 20 meter vegetation sampling transect randomly placed in a suitable (at least 1 acre) infestation of Dalmatian toadflax and timed counts of MEJA adults. Annual vegetation sampling will allow researchers to characterize the plant community and the abundance and vigor of Dalmatian toadflax. Visual counts of MEJA adults will provide researchers with an estimate of MEJA population levels.

Permanent Site Set-up:

To set up the vegetation monitoring transect, you will need: 1) a 25 x 50 cm Daubenmire frame made from PVC (preferred) or rebar, 2) a 20 m tape measure for the transect and plant height, 3) 10 permanent markers (road whiskers and 16 penny nails – see picture below), 4) a post (stake or piece of rebar) to monument the site (see pictures for examples of field equipment), and 5) 30-45 minutes at the site during the **week before Memorial Day**. To set up the transect, place the 20 m tape randomly within the infestation. Mark the beginning of the transect with a post. Place permanent markers every 2 m (for a total of 10 markers) beginning at the 2 m mark and ending with the 20 m mark on the tape measure. Place the Daubenmire frame parallel to the tape on the 50 cm side with the permanent marker in the upper left corner starting at 2 m (see pictures). **Refer to the “timed” data sheet for how to conduct monitoring.** Repeat the frame placement at 2 m intervals for a total of 10 measurements (one at each permanent marker).

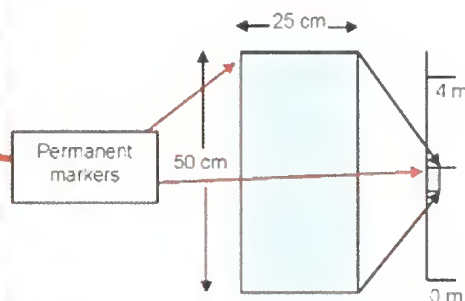
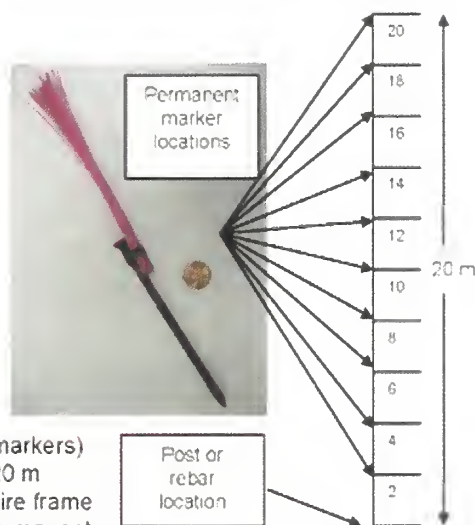

APPENDIX III: STANDARDIZED IMPACT MONITORING PROTOCOL (SIMP) (CONT.)

Monitoring biological control agents is an essential component of a successful biological control program. Monitoring data can be used to accurately document the impact of this weed management practice. This monitoring form has been endorsed by the Nez Perce Biocontrol Center, University of Idaho, Forest Health Protection, Bureau of Land Management, and Idaho State Department of Agriculture. The monitoring information from this form will be used to document vegetation cover, target weed density, and biological control agent abundance. When conducted annually, this monitoring data will document changes that occur over time.

Standardized Impact Monitoring Protocol (SIMP) Biological Control Monitoring Form

General Information:

Observer(s):		Date:	Landowner:
Permanent site? Y N	Site name:		Weed:
Biological control agent:		Insect Stage:	
Lat/Long: N °	W °	UTM Datum:	UTM E:
		UTM Year:	UTM N:

Weed Infestation:

Size in acres:	Picture taken?	Yes	No	If Y, picture direction:
----------------	----------------	-----	----	--------------------------

Vegetation cover (all in %, rows add to 100%):

Frame	Target weed%	Other weed%	Forb/shrub%	Perennial Grass%	Bare ground%	Litter%	Moss%	Total%
1								
2								
3								
4								
5								
6								
7								
8								
9								
10								

Target weed size/density:

Frame	Number of Stems	Height of tallest stem (cm)
1		
2		
3		
4		
5		
6		
7		
8		
9		
10		

Biological control agent:

10 sweeps repeated 6 times (for AP, GA, LA, CYAC & OBER) OR a 3 minute timed count repeated 6 times (for MEJA, ACMA galls & URCA galls)	
Count site	Insect (or gall) count
1	
2	
3	
4	
5	
6	

Notes:

APPENDIX III: STANDARDIZED IMPACT MONITORING PROTOCOL (SIMP) (CONT.)

A step-by-step guide for completing the SIMP biological control monitoring form:

General Information:

- Observer(s) – Who are you?
- Date – Today's date.
- Landowner – Who is the landowner/land manager?
- Permanent? – Is this a permanent monitoring site?
- Site name – Which site are you monitoring? This could have a specific name if it is a permanent site.
- Weed – Which target weed are you are monitoring?
- Biological control agent – Which biological control agent you are monitoring?
- Insect Stage – What is the developmental stage of the agent are you monitoring (egg, larva, nymph, pupa adult)?
- Lat/Long OR UTM – What are the GPS coordinates of the site you are monitoring? If UTM (preferred), what datum and year is your coordinate system?



Annual grass – note stems which are typically solitary or in a few stemmed tufts

Vegetation Cover (all in %, rows add up to 100%) – All percentages are to be estimated to the nearest 5%. If there is a trace of any of the vegetation you monitoring in the frame, round up to 5%.

- Frame – Which frame number are you working on (1 = 2m, 2 = 4m, ..., 10 = 20m)?
- Target weed % – What is % cover of the target weed to the nearest 5%?
- Other weeds % – What is the % cover of any other weeds in the frame to the nearest 5%? Count undesirable annual grasses as weeds
- Forb/Shrub % – What is the % cover of native forbs/shrubs in the frame to the nearest 5%?
- Grass % – What is the % cover of perennial grass to the nearest 5%?
- Bare Ground/Litter % – What is the % cover of bare ground/litter to the nearest 5%?



Perennial grass – note the multiple stem base with multiple year's growth

Target Weed Size/Density

- Frame – Which frame number are you working on (1=2m, 2=4m, ..., 10=20m)?
- Number of stems – How many stems of the target weed are in the frame?
- Height of tallest stems (cm) – How tall is the tallest stem of the target weed in the frame (in cm)?

Biological Control Agent

- Count location – Identify 6 sites at least 5 paces away from the vegetation transect but within the same weed infestation.
- # of insects per 10 sweeps – How many insects are in your net after 10 sweeps of the surrounding vegetation? Take one step between each sweep. Repeat 5 more times (for a total of 6 sweep sites, 60 sweeps) moving at least 2 steps away from the last sweep location (for AP, CYAC, GA, LA, & OBER).
- # of biological control insects or galls per 3 min. count – How many biological control agents or galls do you see in a 3 minute period? Carefully approach the plants and be sure to count insects one time only. Please repeat 5 times (for a total of 6) moving at least 4 paces away from the first count location (for, MEJA, ACMA galls & URCA galls)

APPENDIX IV: GENERAL TOADFLAX BIOLOGICAL CONTROL AGENT MONITORING FORM

SITE: _____ STATE: _____ DATE: _____
year month day

Last name: _____ First name: _____

GPS: Lat N _____ ° _____ ' Long W _____ ° _____ ' Elevation: _____ ft m

UTM: UTM Datum Zone: __ UTM Year: ____ UTM Easting: _____ UTM Northing: _____

TIME: _____ TEMPERATURE: _____ WEATHER: _____

1. Counting Biocontrol Agents This method is used to count adults of the **flower-feeding beetle** and the **stem-mining weevil**, and caterpillars of the **defoliating moth**.

What to do For flower-feeding beetle: Count for 10 minutes
For each agent: For stem-mining weevil: Count for 5 minutes
 For the defoliating moth: Count for 15 minutes

Number of agents observed
🍏 No agents observed
🍏 One agent observed
🍏 2-10 agents observed
🍏 10-50 agents observed
🍏 50-100 agents observed
🍏 >100 agents observed

Agent feeding damage
🍏 No agent feeding observed
🍏 Occasional, scattered feeding damage observed
🍏 Conspicuous, widespread feeding damage observed

2. Sweep-net or tray sampling This method is used for the **seed-feeding weevils** and the **root-galling weevil**.

What to do For sweep net: Sweep plants 5 times; then count beetles
for each sample: For tray sample: Tap plant 10 times to knock beetles onto a tray; then count

Sample	Weevils	Sample	Weevils	Sample	Weevils	Sample	Weevils
1		6		11		16	
2		7		12		17	
3		8		13		18	
4		9		14		19	
5		10		15		20	

Total number of weevils collected: _____

Notes: _____

APPENDIX IV: INSTRUCTIONS FOR GENERAL TOADFLAX BIOLOGICAL CONTROL AGENT MONITORING FORM

Materials needed: stopwatch, sweep net, monitoring form, pencils, clipboard, camera, and GPS unit to record site location.

General: The purpose of this monitoring activity is to estimate the abundance of toadflax biocontrol agents at your monitoring site. Conduct the monitoring when the biocontrol agents are at their peak.

1) Site information: Fill out the site information at the top of the form.

2) Insect counting: To estimate the density of biocontrol agents, you need to count them. Carefully approach the site and avoid disturbing the vegetation. Adults often drop from the vegetation once you touch stems (or even as you approach the quadrat).

Timed Counting: Schedule monitoring to coincide with the adult stage of the biocontrol agent that you are sampling (or caterpillars of *Calophasia*). Randomly walk at a steady pace within the observation area, staying within 32 yd (30 m) of the release point. Accuracy is increased if you avoid backtracking over the same area because both beetles and caterpillars are easily brushed off or fall from toadflax. Beginning at the release point marker, count all the agents you see, concentrating on the top portions of the plants. Count the insects for five, 10, or 15 minutes, as appropriate, and record the number seen.

Sweep net sampling: Using a sturdy canvas net, sweep the upper 3 in (10 cm) of the plant along transects 64 ft (20 m) long. Sweeping lower will give you lots of broken plant parts, but will not necessarily yield any more beetles. Make 20 samples of five sweeps each, sweeping relatively gently through the upper parts of the toadflax plants. Open the net after the five sweeps, count any biocontrol insects collected, then either release the captured insects, or place them in alcohol-filled vials for identity confirmation. You may also empty your sweep net into a white tray for immediate counting, or dump the tray contents into a large plastic cup that you can cover for later counting. The 20 samples can be taken randomly through the toadflax infestation, or by radiating in a straight line away from the release point along each cardinal direction (N, S, E, W). For the latter, do five to seven, five-sweep samples at regular intervals (e.g., 10-16 ft (3-5 m) apart) depending on the size of the toadflax patch.

Tray sampling: This method is particularly useful when monitoring low to medium population densities of biocontrol beetles. Use a white or similarly light-colored plastic tray, pan, or other flat receptacle with sides. The tray should be rectangular or square (for ease of tipping collected insects into specimen vials or other containers), and 12-18 in (30-46 cm) on the longest side. Take 20 samples at each release location. For each sample, gently hold one toadflax stem or a handful of toadflax stems and shake or tap the upper stems 10 times over the collecting tray. This should dislodge at least some of the adults present; they can then be easily counted on the tray and released. Twenty to thirty samples may be taken randomly throughout the toadflax infestation, or you may collect tray samples radiating away from the release point along each cardinal direction (N, S, E, W). For the latter, do five to seven 'beating' samples at regular intervals (e.g., 10-16 ft (3-5 m) apart), depending on the size of the toadflax patch.

APPENDIX V: TOADFLAX QUALITATIVE MONITORING FORM

SITE: _____ STATE: _____ DATE: _____
year month day

Last name: _____ First name: _____

GPS: Lat N ____° ____' Long W ____° ____'

UTM: UTM Datum Zone: __ UTM Year: ____ UTM Easting: _____ UTM Northing: _____

TIME: _____ TEMPERATURE: _____ WEATHER: _____

Biocontrol Insect: _____ Year of release: _____

Toadflax Species (circle): **Dalmatian** yellow

Cover class estimate by plant category							
	0%	1-5%	6-25%	26-50%	51-75%	76-95%	96-100%
Toadflax							
Grasses							
Forbs							
Shrubs							
Trees							

Dominant plant species on site:
Other noxious weeds:

Estimate toadflax density class (✓check one)			
Flowering plants/m ²		Toadflax distribution	
0		Isolated	
1-25		Scattered	
26-50		Scattered-Patchy	
50-75		Patchy	
>75		Continuous	

Toadflax phenology class	
Toadflax Stage	Estimated percent
Seedling	
Rosette	
Bolting	
Flowering	
Senescent	

Comments/Observations _____

APPENDIX VI: TOADFLAX QUANTITATIVE MONITORING FORM

SITE: _____ STATE: _____ DATE: _____
year month day

Last name: _____ First name: _____

GPS: N _____ ° _____ ' W _____ ° _____ ' Elevation: _____ ft m

UTM: UTM Datum Zone: __ UTM Year: ____ UTM Easting: _____ UTM Northing: _____

TIME: _____ TEMPERATURE: _____ WEATHER: _____

Chart A: Cover Class	Class	% Cover	Class	% Cover	Class	% Cover	% Cover	Class
	0	0	2	6-25 %	4	51-75 %	6	95-100 %
1	1-5 %	3	26-50 %	5	76-95 %			

Quad #	Toadflax Stems					Cover Class (use Chart A)					
	# flowering stems	# non-flowering stems	Height (cm) of 4 tallest stems			Toad-flax	Grass	Forbs	Shrubs	Litter	Bare ground
1											
2											
3											
4											
5											
6											
7											
8											
9											
10											
11											
12											
13											
14											
15											
16											
17											
18											
19											
20											

Notes: _____

APPENDIX VI: TOADFLAX QUANTITATIVE MONITORING FORM (SIDE 2)

Quad #	Toadflax Stems				Cover Class (use Chart A)							
	# flowering stems	# non-flowering stems	Height (cm) of 4 tallest stems				Toad-flax	Grass	Forbs	Shrubs	Litter	Bare ground
21												
22												
23												
24												
25												
26												
27												
28												
29												
30												
31												
32												
33												
34												
35												
36												
37												
38												
39												
40												

Notes: _____

INSTRUCTIONS FOR APPENDIX VI: TOADFLAX QUANTITATIVE MONITORING FORM

Materials needed: 1.1 yd (1 m) measuring stick, 3.5 ft² (0.1 m²) quadrat frame, data sheets, pencils, clipboard, camera, and GPS unit to relocate quadrats.

General: The purpose of this activity is to estimate the abundance of other vegetation in the community, and to record measurements of toadflax plant attributes. Monitoring is easier with two people, one to make the observations and the other to record data.

1) Site information: Fill out the site information at the top of the form.

2) Locate the transect and position the quadrat: After you have completed the insect counts, locate the transect using the GPS coordinates and the permanent marker.

3) Position the quadrat frame: Position the quadrat frame along the transect, as close to the ground as possible, carefully positioning the quadrat frame along that transect line. Gently arrange vegetation so that plant parts are either within or outside, rather than underneath, the frame, but be sure not to damage the plants. The quadrat should be in the same location as the previous year's quadrat.

4) Count stems: Count the number of toadflax stems, beginning at one corner of the quadrat and working systematically across the quadrat. Count the number of flowering and non-flowering stems.

5) Measure stems: Select the four tallest toadflax stems in each quadrat (if there are fewer than four stems/quadrat, measure all that are present). Measure the stem height to the closest cm.

6) Estimate percent cover: Standing over the frame, estimate how much of the quadrat is covered by toadflax. Then estimate the percent cover of grasses, forbs, shrubs, plant litter, and bare ground. Use cover estimates in Chart A to estimate percent cover class.

7) Other observations: Record any general observations or useful information such as disturbances, grazing, fire, etc., for the sample quadrat or the site in general.

United States
Department of
Agriculture



**NATIONAL
AGRICULTURAL
LIBRARY**

Advancing Access to
Global Information for
Agriculture

* NATIONAL AGRICULTURAL LIBRARY



1022497936