

- I. *The Description of a new Instrument for taking Angles.* By John Hadley, Esq; Vice-Pr. R. S. communicated to the Society on May 13. 1731.

THE Instrument is design'd to be of Use, where the Motion of the Objects, or any Circumstance occasioning an Unsteadiness in the common Instruments, renders the Observations difficult or uncertain.

The Contrivance of it is founded on this obvious Principle in Catoptricks: That if the Rays of Light diverging from, or converging to any Point, be reflected by a plane polish'd Surface, they will, after the Reflection, diverge from, or converge to another Point on the opposite Side of that Surface, at the same Distance from it as the first; and that a Line perpendicular to the Surface passing through one of those Points, will pass through both. Hence it follows, that if the Rays of Light emitted from any Point of an Object be successively reflected from two such polish'd Surfaces; that then a third Plane, perpendicular to them both, passing through the emitting Point, will also pass through each of its two successive Images made by the Reflections: All three Points will be at equal Distances from the common Interfection of the three Planes; and if two Lines be drawn thro' that common Interfection, one from the original Point in the Object, the other from that Image of it which is made by the second Reflection; they will comprehend

U

hend

hend an Angle double to that of the Inclination of the two polish'd Surfaces.

FIG. I. Let $R F H$ and $R G I$ represent the Sections of the Plane of the Figure by the polish'd Surfaces of the two Specula $B C$ and $D E$, erected perpendicularly thereon, meeting in R , which will be the Point where their common Section, perpendicular likewise to the same Plane, passes it, and $H R I$ is the Angle of their Inclination. Let $A F$ be a Ray of Light from any Point of an Object A falling on the Point F of the first Speculum $B C$, and thence reflected into the Line $F G$, and at the Point G of the second Speculum $D E$ reflected again into the Line $G K$, produce $G F$ and $K G$ backwards to M and N , the two successive Representations of the Point A ; and draw $R A$, $R M$, and $R N$.

Since the Point A is in the Plane of the Scheme, the Point M will be so also by the known Laws of Catoptricks. The Line $F M$ is equal to $F A$, and the Angle $M F A$ double the Angle $H F A$ or $M F H$; consequently $R M$ is equal to $R A$, and the Angle $M R A$ double the Angle $H R A$ or $M R H$. In the same manner the Point N is also in the Plane of the Scheme, the Line $R N$ equal to $R M$, and the Angle $M R N$ double the Angle $M R I$ or $I R N$: Subtract the Angle $M R A$ from the Angle $M R N$, and the Angle $A R N$ remains equal to double the Difference of the Angles $M R I$ and $M R H$, or double the Angle $H R I$, by which the Surface of the Speculum $D E$ is reclin'd from that of $B C$; and the Lines $R A$, $R M$ and $R N$ are equal.

Corol. 1. The Image N will continue in the same Point; altho' the two Specula be turn'd together circularly on the Axis R , so long as the Point A remains elevated on the Surface of BC : provided they retain the same Inclination.

Corol. 2. If the Eye be plac'd at L , (the Point where the Line AF continued cuts the Line GK ;) the Points A and N will appear to it at the angular Distance ALN , which will be equal to ARN : For the Angle ALN is the Difference of the Angles FGN and GFL ; and FGN is double FGI ; and GFL double GFR , and consequently their Difference double FRG or HRI : Therefore L is in the Circumference of a Circle passing through A , N , and R .

Corol. 3. If the Distance AR be infinite, those Points A and N will appear at the same angular Distance, in whatever Points of the Scheme the Eye and Specula are placed: Provided the Inclination of their Surfaces remain unaltered, and their common Section parallel to itself.

Corol. 4. All the Parts of any Objects will appear to an Eye viewing them by the two successive Reflections, as before described, in the same Situation as if they had been turn'd together circularly round the Axis R , keeping their respective Distances from one another, and the Axis, with the Direction HI , *i. e.* the same Way the second Speculum DE reclines from the first BC .

Corol. 5. If the Specula be suppos'd to be at the Center of an infinite Sphere; Objects in the Circumference of a great Circle, to which their common Section is perpendicular, will appear remov'd by the two

Reflections, through an Arch of that Circle, equal to twice the Inclination of the Specula, as is before said. But Objects at a Distance from that Circle will appear removed thro' the similar Arch of a Parallel: Therefore the Change of their apparent Place will be measured by an Arch of a great Circle, whose Chord is to the Chord of the Arch equal to double the Inclination of the Specula, as the Sines Complements of their respective Distances from that Circle are to the Radius: And if those Distances are very small, the Difference between the apparent Translation of any one of these Objects, and the Translation of those which are in the Circumference of the great Circle aforesaid, will be to an Arch equal to the versed Sine of the Distance of this Object from that Circle, nearly as double the Sine of the Angle of Inclination of the Specula, is to the Sine Complement of the same.

FIG. II. The Instrument consists of an Octant ABC, having on its Limb BC an Arch of 45 Degrees, divided into 90 Parts or half Degrees; each of which answers to a whole Degree in the Observation. It has an Index M L moveable round the Center, to mark the Divisions: And upon this, near the Center, is fix'd a plane Speculum E F perpendicular to the Plane of the Instrument, and making such an Angle with a Line drawn along the middle of the Index, as will be most convenient for the particular Uses the Instrument is designed for; (for an Instrument made according to Fig. 2. the Angle L M F may be of about 65 Degrees.) I K G H is another smaller plane Speculum, fix'd on such Part of the Octant as will likewise be determin'd by its particular Use, and having its Surface in such Direction, that when the Index is brought to mark
the

the beginning of the Divisions (*i. e.* 0°) it may be exactly parallel to that of the other; this Speculum being turned towards the Observer, and the other from him. PR is a Telescope fix'd on one Side of the Octant, having its Axis parallel to that Side, and passing near the middle of one of the Edges IK or IH of the Speculum IKGH; so that half its Object-Glass may receive the Rays reflected from that Speculum, and the other half remain clear to receive them from a distant Object. The two Specula must also be dispos'd in such manner, that a Ray of Light coming from a Point near the middle of the first Speculum, may fall on the middle of the second in an Angle of 70 Degrees or thereabouts, and be thence reflected into a Line parallel to the Axis of the Telescope, and that a clear Passage be left for the Rays coming from the Object to the Speculum EF by the Side HG. ST is a dark Glass fix'd in a Frame, which turns on the Pin V; by which Means it may be plac'd before the Speculum EF, when the Light of one of the Objects is too strong: Of these there may be several.

FIG. III. In the distinct Base of the Telescope, represented by the Circle *abcdef*, are placed three Hairs, two of which, *ac* and *bd*, are at equal Distances from, and parallel to the Line *gh*, which passes through the Axis, and is parallel to the Plane of the Octant: The third *fc* is perpendicular to *gh* through the Axis.

The Instrument, as thus described, will serve to take any Angle not greater than 90 Degrees; but if it be design'd for Angles from 90 to 180 Degrees, the polish'd Surface of the Speculum EF (Fig. 2.) must be turn'd
towards.

towards the Observer ; the second $I K G H$ must be brought forward to the Position $N O$ so as to receive on its Middle the Rays of Light from the middle of the first in an Angle of about 25 Degrees, their Surfaces being perpendicular to one another when the Index is brought to the End of the divided Arch next C ; and this second must stand five or six Inches wide of the first, that the Head of the Observer may not intercept the Rays in their Passage towards it, when the Angle to be observ'd is near 180° . The smaller Speculum is fix'd perpendicularly on a round brass Plate, tooth'd on the Edge ; and may be adjusted by an endless Screw.

In order to make an Observation, the Axis of the Telescope is to be directed towards one of the Objects, the Plane of the Instrument passing as near as may be through the other, which must lie to that Hand of the Observer, as the particular Form of the Instrument may require ; *viz.* the same Way that the Speculum $E F$ does from $I K G H$, if it be compos'd according to this Figure and Description. The Observer's Eye being applied to the Telescope, so as to keep sight of the first Object ; the Index must be moved backward and forward till the second Object is likewise brought to appear through the Telescope, about the same Distance from the Hair cf (Fig. 3.) as the first : If then the Objects appear wide of one another, as at i and k , the Instrument must be turn'd a little on the Axis of the Telescope, till they come even, or very nearly so, and the Index must be remov'd till they unite in one, or appear close to one another in a Line parallel to cf , both of them being kept as near the Line $g b$ as they can. If the Instrument be then
turn'd

turn'd a little on any Axis perpendicular to its Plane, the two Images will move along a Line parallel to gh , but keep the same Position in respect of one another; so that in whatever Part of that Line they be observed, the Accuracy of the Observation will be no otherwise affected than by the Indistinctness of the Objects. If the two Objects be not in the Plane of the Instrument, but equally elevated on, or depress'd below it, they will appear together at a Distance from the Line gh , when the Index marks an Angle something greater than their nearest Distance in a great Circle: And the Error of the Observation will increase nearly in Proportion to the Square of their Distance from that Line; but may be corrected by help of the fifth Corollary. Suppose the Hairs ae and bd , each at a Distance from the Line gh , equal to $\frac{1}{4}$ of the focal Length of the Object-Glass, so as to comprehend between them the Image of an Object, whose Breadth to the naked Eye is a little more than $2^\circ \frac{1}{4}$; and let the Images of the Objects appear united at either of those Hairs: Then as the Sine Complement of half the Degrees and Minutes mark'd by the Index, is to the doubled Sine of the same; so is one Minute to the Error which is always to be subtracted from the Observation. Other Hairs may also be plac'd in the Area $abcdef$, parallel to gh , and at Distances from it proportional to the square Roots of the Numbers 1, 2, 3, 4, &c. and then the Errors to be subtracted from the same Observation made at each of those Hairs respectively, will be in Proportion to the Numbers 1, 2, 3, 4, &c. This Correction will always be exact enough if the Observer take care

care (especially when the Angle comes near 180°) to keep the Plane of the Instrument from varying too much from the great Circle passing thro' the Objects.

In regard to the Workmanship, if an Exactness be required in the Observations, the Arch ought to be divided with the greatest Care; because all Errors committed in the Division are doubled by the Reflections. The Index must have a steady Motion on the Center, so that the Axis of it remain always perpendicular to the Plane of the Octant; for if that alter, it will be liable to vary the Inclination of the Speculum it carries to the other: The Motion must likewise be easy, lest the Index be subject to bend edge-ways: For the same reason it should be as broad at that End next the Center as conveniently can be. The Specula should have their Surfaces of a true flat; because a Curvature in either of them, beside rendering the Object indistinct, will vary its Position, when seen by Reflection from different Parts of them: They must also be of a sufficient Length and Breadth for the Telescope to take in a convenient Angle without losing the Use of any Part of the Aperture of its Object-Glass, and that in all the different Positions of the Index. They may be either of Metal or Glass Plates foil'd, having their two Surfaces as nearly parallel as they can; yet a small Deviation may be allowed; provided either their thickest or thinnest Edges (and consequently the common Section of their Surfaces) be parallel to the Plane of the Octant: For in that Case, though there are several Representations of the Object, they will be always very near one another in a Line parallel to cf ; and any of them may be used,

used, except when the Angle to be observed is very small. The chief Inconvenience will be, that a small Star will be more difficultly discerned, the Light being divided among the several Images. The Telescope may be contrived to alter its Situation, so as to receive the reflected Rays on a greater or less Part of its Object-Glass, if the Objects differ in Brightness. The second Speculum may have a Part unfoil'd, that if either of them be sufficiently luminous, the less bright may be seen through it by the whole Aperture. If the Sun be one of the Objects, or the Moon be compared with a smaller fix'd Star; their reflected Images must be still farther weakened by the Interposition of one or more of the dark Glasses S T. An exact Position of the Telescope is not necessary; and the Instrument may be used without one, the Disposition of the Specula, with regard to the Sector and Index, being such as may allow the Eye to be brought as near the second Speculum as may be, and make the Instrument the most commodious for the Observer.

It will be easy to judge, that scarce any greater Degree of Steadiness is requisite in the Pedestal, or Machine which carries this Instrument, than what is sufficient for the Telescope us'd with it: For although the vibrating Motion of the Instrument may occasion the Images of the Objects also to vibrate cross one another; their apparent relative Motion will be very nearly in Lines parallel to *cf*; and it will not be difficult to distinguish whether they coincide in crossing one another, or pass at a Distance: And if the Objects are near one another, and the Telescope magnify but about four or five Times, it may be held in

the Hand without any standing Support. In this Manner the Altitude of the Sun, Moon, or some of the brighter Stars from the visible Horizon may be taken at Sea, when it is not too rough.

FIG. IV. shews an Instrument designed for this Purpose; differing from the foregoing Description chiefly in the placing the Specula and Telescope, with regard to the Sector and Index; it has also a third Speculum *NO* dispos'd according to the Directions when the Angle is greater than 90 Deg. whose Use is to observe the Sun's Altitude by Means of the opposite Part of the Horizon. In placing these two smaller Specula, it will be farther necessary to take care that the Speculum *IKGH* do not stand so as to intercept any of the Rays coming from the greater one fix'd on the Index to the third *NO*, nor either of them hinder the Index from coming Home to the End of the divided Arch. *WQ* is a Director for the Sight; which is necessary when the Telescope is not made use of. This consists of a long narrow Piece, which slides on another fix'd on the back of the Octant, and carries at each End a Sight erected perpendicularly on it: It may be removed at Pleasure, and exchanged for the Telescope, which slides on in the same manner, both serving indifferently with either of the two smaller Specula. The Eye is to be plac'd close behind the Sight at *W*; and the Thread stretch'd across the opening of the other Sight at *Q* perpendicular to the Instrument is to assist the Observer in holding it in a vertical Posture, who is to keep this Thread as near as he can parallel to the Horizon, and the Object near the upright one. How far an Instrument of this Kind

Kind may be of Use at Sea to take the Distance of the Moon's Limb from the Sun or a Star, in order to find the Ship's Longitude, when the Theory of that Planet is perfected, I leave to Trials to determine.

The Society have the Satisfaction of knowing that Theory to be already brought to a good Degree of Certainty and Exactness, thro' the consummate Skill in Astronomy, and indefatigable Diligence in observing, of a very learned Member; and have great Reason to hope, that this useful and difficult Part of Astronomy will in a little time appear to be absolutely compleated by the continued Labour and Application of some of their own Body.

II. *An Extract of a Dissertation De Styliis Veterum, & diversis Chartarum generibus, [by the Hon. Sir John Clerk, one of the Barons of the Exchequer in Scotland, and F. R. S.] By Roger Gale, Esq; Vice-President and Treasurer R. S.*

THE learned and judicious Author takes occasion from some antique Brass Implements found near the Wall of *Antoninus Pius*, now named *Graham's Dyke*, in *Scotland*, to give us this curious Dissertation upon the *Stylus*, an Instrument used by the Ancients for Writing, with the Figures of some of them annex'd in a Copper Plate; two of which are represented in the Shape and Form of the Roman *Fibula*; but the Author is of Opinion they were designed for a different Purpose, for which he produces very cogent Reasons.

easy to keep the Plane of the Instrument so near that of the before-mentioned great Circle as not to want any, if the Situation of that Circle be known: If it be not, the Observer, when he sees the two Objects together, may turn the Instrument on the Axis of the Telescope, 'till he finds that Position of it by which he obtains the least Angle; and this (if the Specula are set truly perpendicular to the Plane of the Instrument) will always happen when the Objects appear to coincide in the Line $g b$, as expressed in the third Fig. of *Transf.* No 420.

In Page 152 of the same, a Rule is given for finding to which Hand of the Observer the Object seen by Reflection ought to lie, but is restrained to the particular Form of the Instrument there described. The general Rule is, that when the Index is brought to the beginning of the Scale (*i. e.* to 0° when the Instrument is designed for Angles under 90° , or to 90° when it is designed for Angles from 90° to 180°) if then a Line be imagined to be drawn on it parallel to the Axis of the Telescope, or Line of Direction of the Sight, so as to point towards the Object seen directly; which ever way this Line is carried by the Motion of the Index along the Arch from 0° towards 90° in the first Case, or from 90° towards 180° in the second, the same way the Object seen by Reflection ought to lie from that which is seen directly.

Erratum, Pag. 154. Line 24, read, *They may be either of Metal, or Glass Plates foil'd, having their two Surfaces, &c.*

Fig. I.

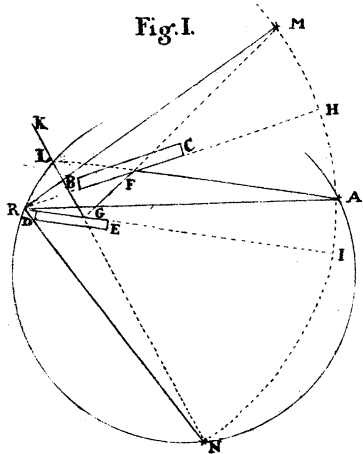

Fig. II.

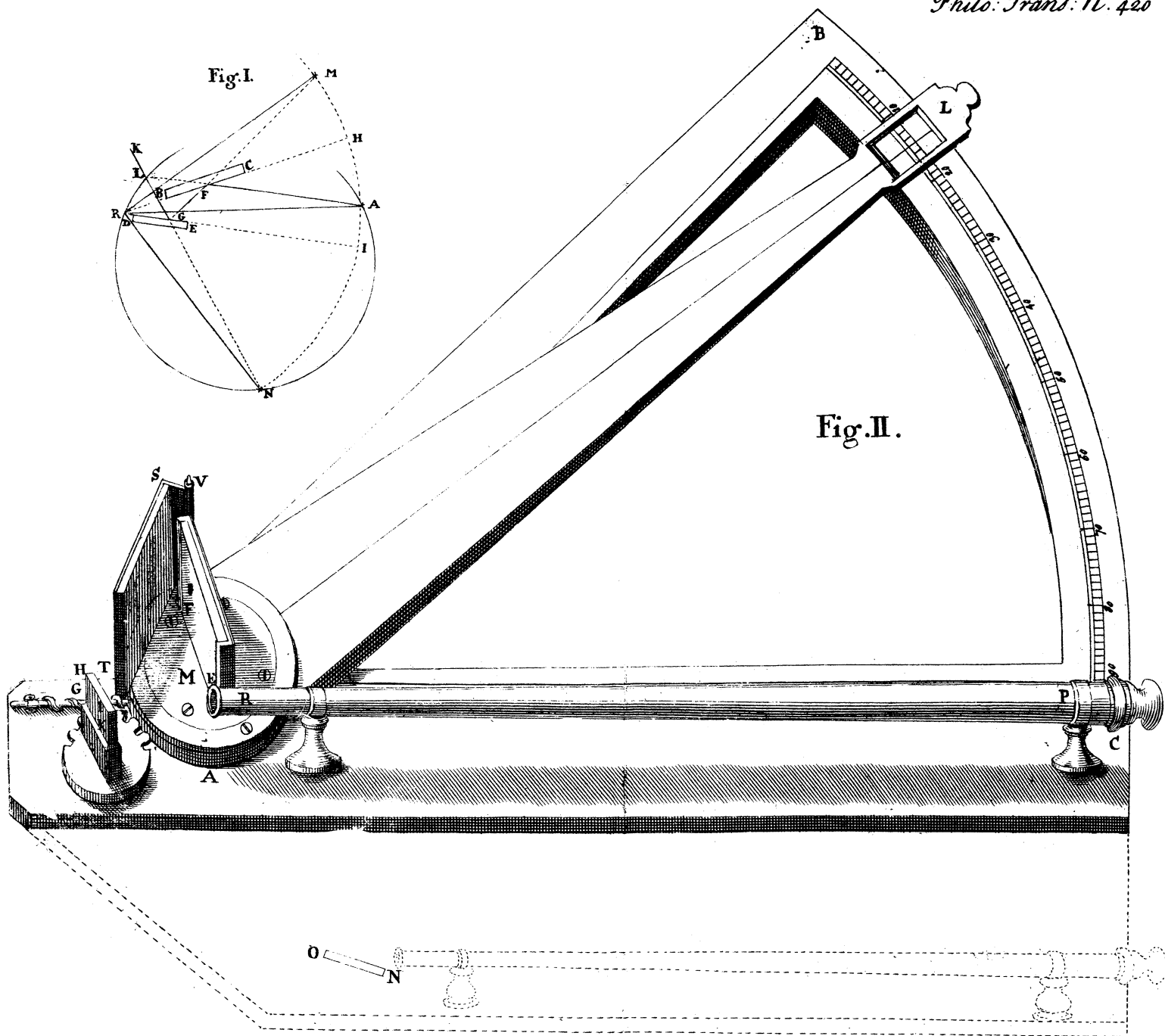

Fig. IV.

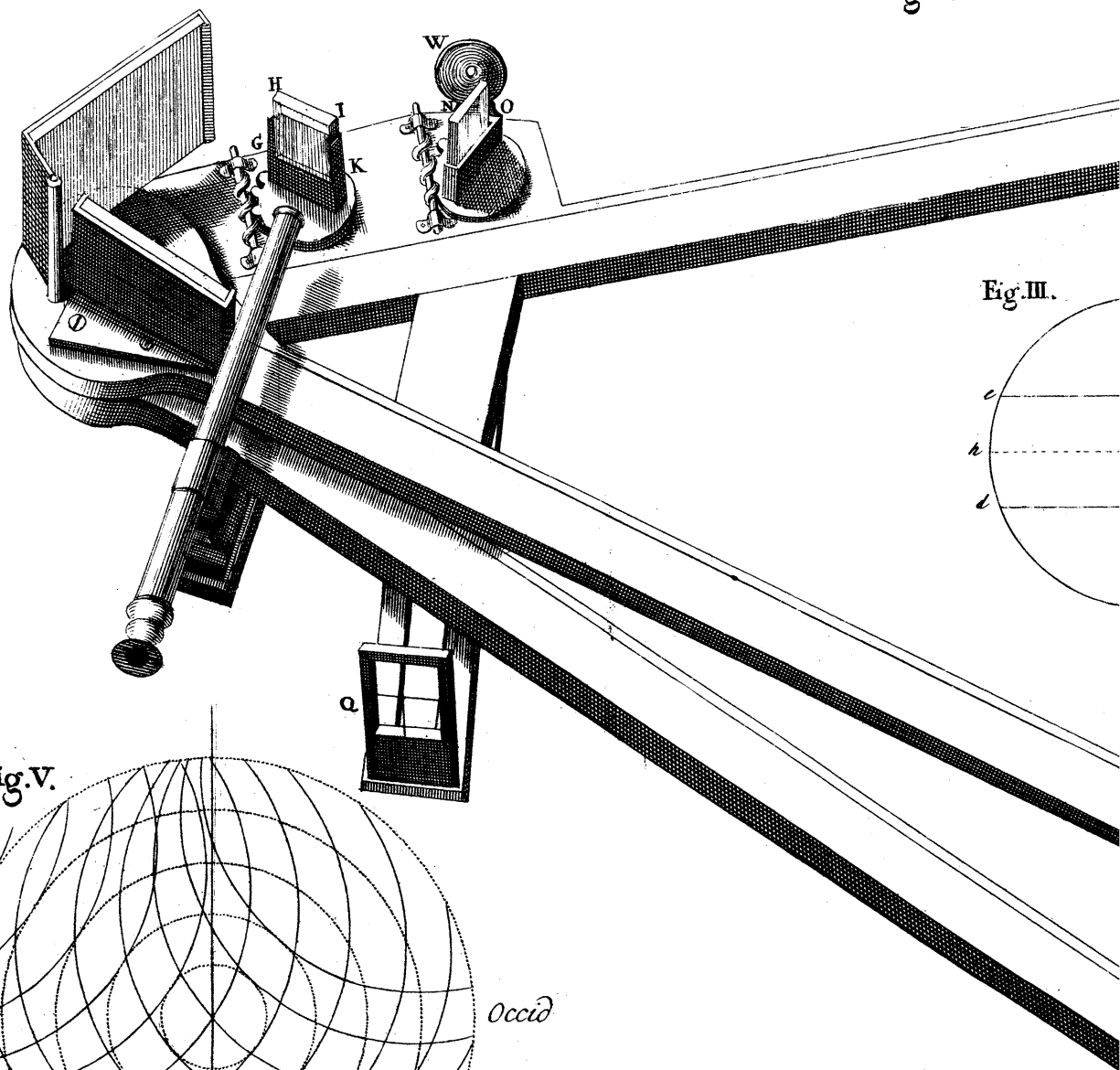

Fig. III.

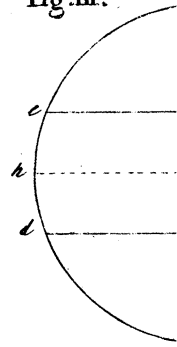
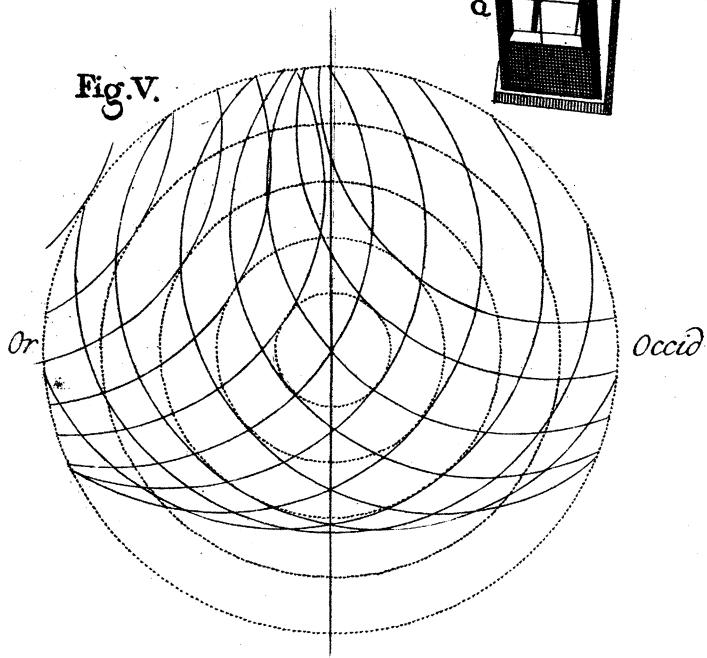

Fig. V.



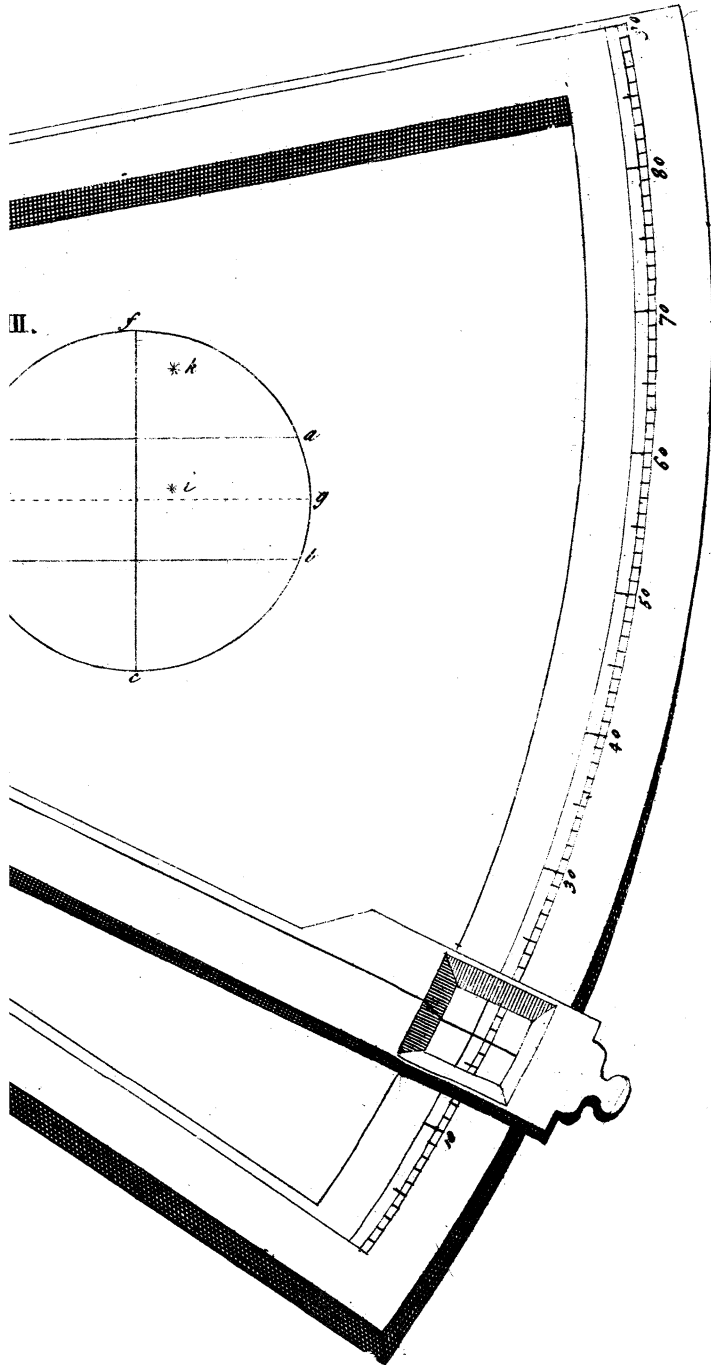

Fig. IV.

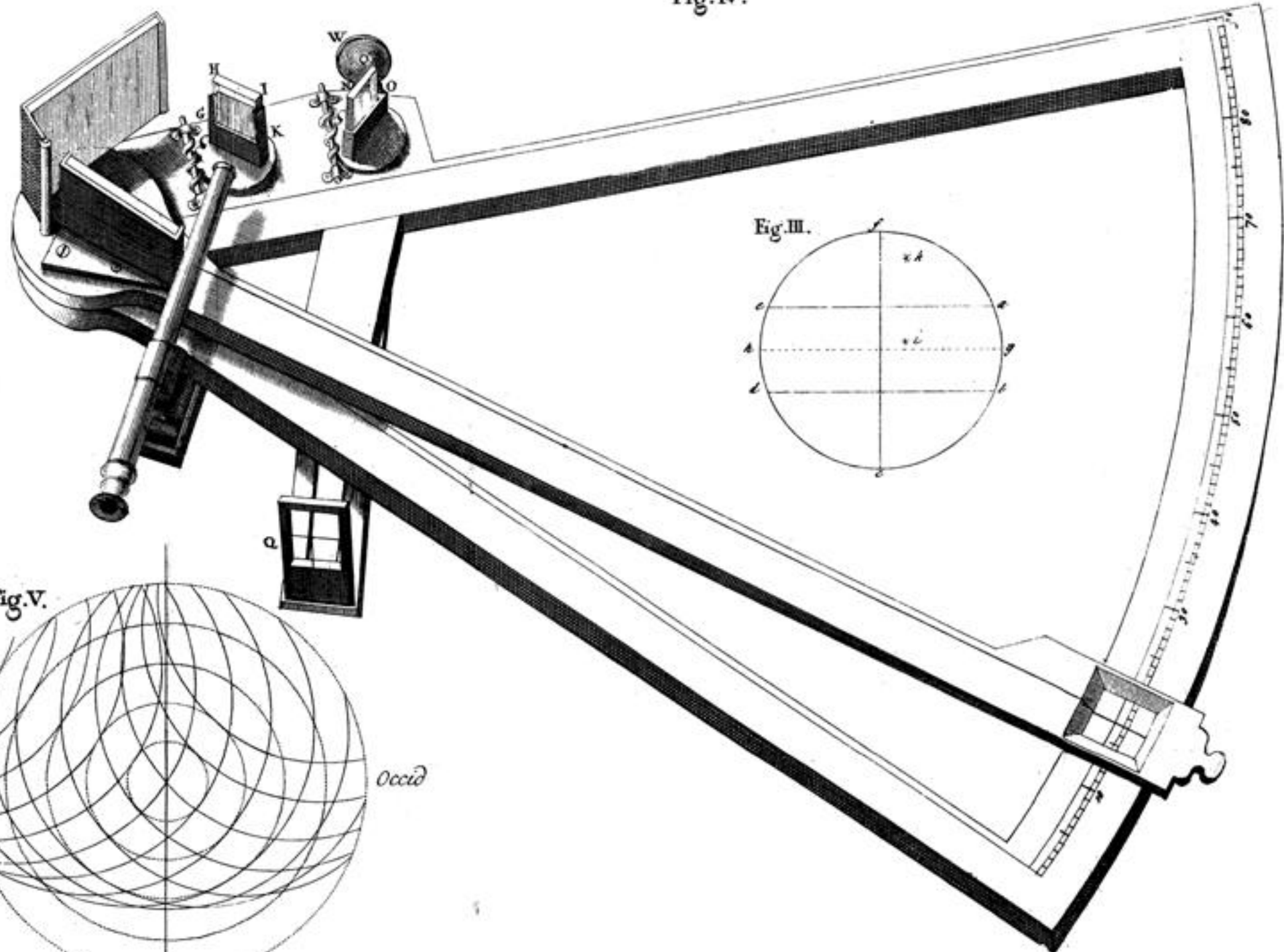

Fig. V.

