

TM 9-1005-229-12

DEPARTMENT OF THE ARMY TECHNICAL MANUAL

OPERATOR'S AND ORGANIZATIONAL MAINTENANCE
MANUAL INCLUDING REPAIR PARTS AND
SPECIAL TOOLS LISTS

SUBMACHINE GUN, CALIBER .45: M3, W/E
(1005-672-1767)

SUBMACHINE GUN, CALIBER .45: M3A1, W/E
(1005-672-1771)

This reprint includes all changes in effect
at the time of publication - Changes 1 and 2.

HEADQUARTERS, DEPARTMENT OF THE ARMY
OCTOBER 1969

WARNING

DANGEROUS PROCEDURES

Care must be exercised to either have the submachine gun raised or pointed down range when loading. Load the weapon only when ready to fire. The submachine gun has no mechanical means of locking the trigger. The insertion of a loaded magazine loads the weapon. If the cover is open and the bolt cocked, pressure on the trigger will fire the gun. If an unlocked weapon is dropped, it may fire whether the bolt is cocked or not.

Unlock the loaded weapon only when it is raised for firing. When firing long bursts, the weapon has a tendency to move up and to the right. The firer can control this tendency by always taking a correct firing position.

DANGEROUS CONDITIONS

Before firing, the firer must be sure that the bore of the submachine gun is free from any obstruction in the bore that will result in damage to the weapon and possible injury to personnel.

Clear the weapon of all ammunition before starting the inspection. Remove the magazine and check the chamber to insure it is empty. Do not actuate the trigger until the weapon has been cleared.

DANGEROUS SOLUTIONS

Avoid skin contact with P-C-111. The compound should be washed off thoroughly with running water if it comes in contact with the skin. A good lanolin base cream, after exposure to the compound, is helpful. The use of rubber gloves and protective equipment is recommended.

CHANGE

No.1



HEADQUARTERS
DEPARTMENT OF THE ARMY
WASHINGTON, D.C. 21 November 1972

**Operator's and Organizational Maintenance Manual
Including Repair Parts and Special Tools Lists**

**SUBMACHINE GUN, CALIBER .45: M3, W/E
(1005-672-1767)**

**SUBMACHINE GUN, CALIBER .45: M3A1, W/E
(1005-672-1771)**

TM 9-1005-229-12, 20 October 1969, is changed as follows:

Page 1-1. Paragraph 1-2*b.* Change last sentence to read: Reports should be submitted on DA Form 2028 (Recommended Changes to Publications) and forwarded direct to: Commander, US Army Weapons Command, ATTN: AMSWE- MAS-SP, Rock Island, IL 61201.

Page 1-1. Paragraph 1-4. Add the following statement at end of paragraph: "One cartridge magazine (1, fig. C-1) and one small arms sling (3, fig. C-3) are supplied with each weapon as a component item."

Page 3-3. Add the following table:

Table 3-2.1. Expendable and Consumable Supplies

FSN	Description	Symbol
8020-244-0153	BRUSH, ARTISTS: Metal ferrule, flat, chisel edges 7/16 wide by 1 1/8 inches long, exposed H-H-241 (81348).	
7920-205-2401	BRUSH, CLEANING, TOOL AND PARTS: Round, 100 percent tampico fiber, 1 1/16 at ferrule brush diam 2 7/8 clear of block brush length MS16746-29 (96906).	

*Table 3-2.1. Expendable and Consumable Supplies—
Continued*

FSN	Description	Symbol
6850-965-2332	CARBON REMOVING COMPOUND: (5 gal pail) P-C-111 (81348). CLEANING COMPOUND, RIFLE BORE: Mil-C-372 (81349).	RBC
6850-224-6656	2 oz bottle	
6850-224-6657	8 oz can	
6850-224-6663	1 gal can	
5350-221-0872	CLOTH, ABRASIVE, CROCUS: Ferric oxide and quartz, jean-cloth-backing, closed coating 9 inches wide, 11 inches long, 50-sh-sleeve P-C-458 (81348).	
6850-281-1985	DRY CLEANING SOLVENT: (1 gal can) P-D-680 (81348).	SD
	LUBRICATING OIL, GENERAL PURPOSE: VV-L-800 (81348).	PL-S
9150-273-2389	4 oz can	
9150-231-6689	1 qt. can	
9150-292-9689	LUBRICATING OIL, WEAPONS: For below zero operations (1 qt can) MIL-L-14107 (81349).	LAW
7920-205-1711	RAG, WIPING: Cotton (50 lb bale) DDD-R-30, class 2, grade B (81348).	
1005-288-3565	SWAB, SMALL ARMS CLEANING: Cotton 2 1/2 sq. (1000 in pkg) 5019316 (19204).	

Page C-1. Appendix C is changed as follows:

Change title to read:

**BASIC ISSUE ITEMS LIST
AND
ITEMS TROOP INSTALLED OR AUTHORIZED LIST
AND
REPAIR PARTS
AND
SPECIAL TOOLS LIST**

Paragraph C-1 is changed to read:

C-1. Scope

This appendix lists basic issue items, items troop installed or authorized, and repair parts and special tools required by the crew/operator for operation and required for the performance of organizational maintenance of the caliber .45 submachine gun M3 and M3A1.

Paragraph C-2 is changed as follows:

C-2 General

These basic issue items, items troop installed or authorized, and repair parts and special tools lists are divided into the following sections:

a. Basic Issue Items List-Section II. A list, in alphabetical sequence, of items essential for operation of the end item, which are furnished with and must be turned in with the end item.

b. Items Troop Installed or Authorized List—Section III.* A list, in alphabetical sequence, of items required by the operator for sustained operation of the end item. These discretionary items will be requisitioned by the unit in accordance with its mission requirements. They may accompany the end item, but are not subject to be turned in with it.

Delete paragraph *c*. Change paragraphs, *d* to *c*, *e* to *d* and *f* to *e*.

Page C-2. Paragraphs C-3*d* through *j* are superseded as follows:

d. Unit of Measure (U/M). This designation indicates the standard or basic quantity by which the listed item is used in performing the actual maintenance function. This measure is expressed by a two-character alphabetical abbreviation; e.g., ea for each, and is the basis used to indicate quantities. When the unit of measure differs from the unit of issue, the lowest unit of issue that will satisfy the required units of measure will be requisitioned.

e. Quantity Furnished with Equipment (Basic Issue Items). This designation indicates the quantity of the item authorized to be used with the equipment.

f. Quantity Authorized (Items Troop Installed or Authorized). This designation indicates the quantity of the item authorized to be used with the equipment.

g. Quantity Incorporated in Unit. This designation indicates the quantity of the item used in that functional group/assembly. A V appearing in this column in lieu of a quantity indicates that no specific quantity is applicable; e.g., shims, spacers; etc.

Paragraph *k* is changed to *h*.

Page C-3. Paragraph *l* is changed to *i*.

Page C-4. Section II is superseded as follows:

Section II. BASIC ISSUE ITEMS LIST

(1) Federal stock No	(2) Description <i>Reference number & mfg. code</i>	(3) Unit of meas	(4) Qty furn with equip	(5) Illustration	
				(a) Fig. No.	(b) Item No.
1005-726-5879	CAP, MAGAZINE: 7265879 (19204).	ea	1	C-3	6
1005-726-5628	FLASH HIDER ASSEMBLY: M9 765628 (19204).	ea	1	C-3	5

Page C-5. Section III is superseded as follows:

Section III. ITEMS TROOP INSTALLED OR AUTHORIZED LIST

(1) Federal stock No	(2) Description <i>Reference number & mfg. code</i>	(3) Unit of meas	(4) Qty auth
1005-550-4036	BRUSH CLEANING, SMALL ARMS: M5 bore 5504036 (19204).	ea	1
1005-610-8828	BRUSH, CLEANING SMALL ARMS: M6 chamber 6108828 (19206).	ea	1
1005-726-5879	CAP, MAGAZINE 7265879 (19204).	ea	14
1005-565-3431	FILLER, MAGAZINE: M1 5653431 (19204).	A ea	1
1005-565-3427	MAGAZINE CARTRIDGE: 5653427 (19204).	ea	14
1005-556-4364	OILER, CARBINE 5564364 (19204).	A ea	1

Page C-6. Delete section IV.

By Order of the Secretary of the Army:

CREIGHTON W. ABRAMS
General, United States Army
Chief of Staff

Official:

VERNE L. BOWERS
Major General, United States Army
The Adjutant General

Distribution:

To be distributed in accordance with DA Form 12-40 (qty rqr block No. 108) Organizational Maintenance Requirements for Submachine Guns, Caliber .45, M3 and M3A1.

CHANGE }
No. 2 }

HEADQUARTERS
DEPARTMENT OF THE ARMY
WASHINGTON, DC, 13 May 1985

Operator's and Organizational Maintenance Manual
Including Repair Parts and Special Tools Lists

SUBMACHINE GUN, CALIBER .45: M3, W/E
(1005-00-672-1767)

SUBMACHINE GUN, CALIBER .45: M3A1, W/E
(1005-00-672-1771)

TM 9-1005-229-12, 20 October 1969, is changed as follows:

Title is changed as shown above.

Page 1-1 Paragraph 1-2b. Change address to read: Commander, US Army Armament, Munitions and Chemical Command, ATTN: AMSMC-MAS, Rock Island, IL 61299-6000.

Page 1-2 Paragraph 1-6. Change last line to read: Maximum Range (Ball 30° elevation) 1760 yards or 1609 meters.

Page 3-3 Table 3-2 Preventative Maintenance Checks and Services
Add item numbers 1, 7, 8, 9, 10, and 12 in Quarter (Q) Column to indicate quarterly inspection is necessary.

Page C-3 Paragraph 3k(4), Line 5. Change address to read: Commander, US Army Armament, Munitions and Chemical Command, ATTN: AMSMC-MAS, Rock Island, IL 61299-6000,

Page C-3 Paragraph 3k(4), Line 10. Change address to read: Commander, US Army Armament, Munitions and Chemical Command,

Page C-7 Section V. Repair Parts List. Delete item 7 in its entirety.

Page C-7. The table is changed as shown.

Page C-10 Section VII. Federal Stock Number and Reference Number Cross-Reference to figure and item number. Change Stock Number 1005-716-1911 to 1005-716-1913.

Page C-11 Figure C-11 (M3A1) is changed as shown.

Section V. REPAIRPARTSLIST

(1) Source Maint and Recov Code			(2) Federal Stock No.	(3) Description		(4) Unit of Meas	(5) Qty Inc in Unit	(6) 15-day organizational maintenance alw				(7) Illustration	
(a) Source	(b) Maint	(c) Recov		Reference Number & Mfr Code	Usable on Code			(a) 1-5	(b) 6-20	(c) 21-50	(d) 51-100	(a) Fig. No.	(b) Item No.
P	O	--	1005-716-1913	CAP: 7161913 (19204)	B	EA	1	*	2	2	3	C1	7
P	O	--	1006-716-1911	GASKET: SYNTH-RBR, 0.490 OD, 0.290 ID, 0.060 THK 7161911 (19204)	B	EA	1	2	2	2	3	C1	8
P	O	--	5310-716-1905	NUT, PLAIN, ROUND: S, PHOS-CTD, 7/16 20NF-2, 0.090 IN.THK 7161905 (19204)	B	EA	1	*	2	2	3	C1	9
P	O	--	5310-261-7161	WASHER LOCK: 101836 (81580)	B	HD	1	*	2	2	3	C1	10
P	O	--	1005-731-2910	OILER: 7312910 (19204)		EA	1	*	2	2	3	C1	11

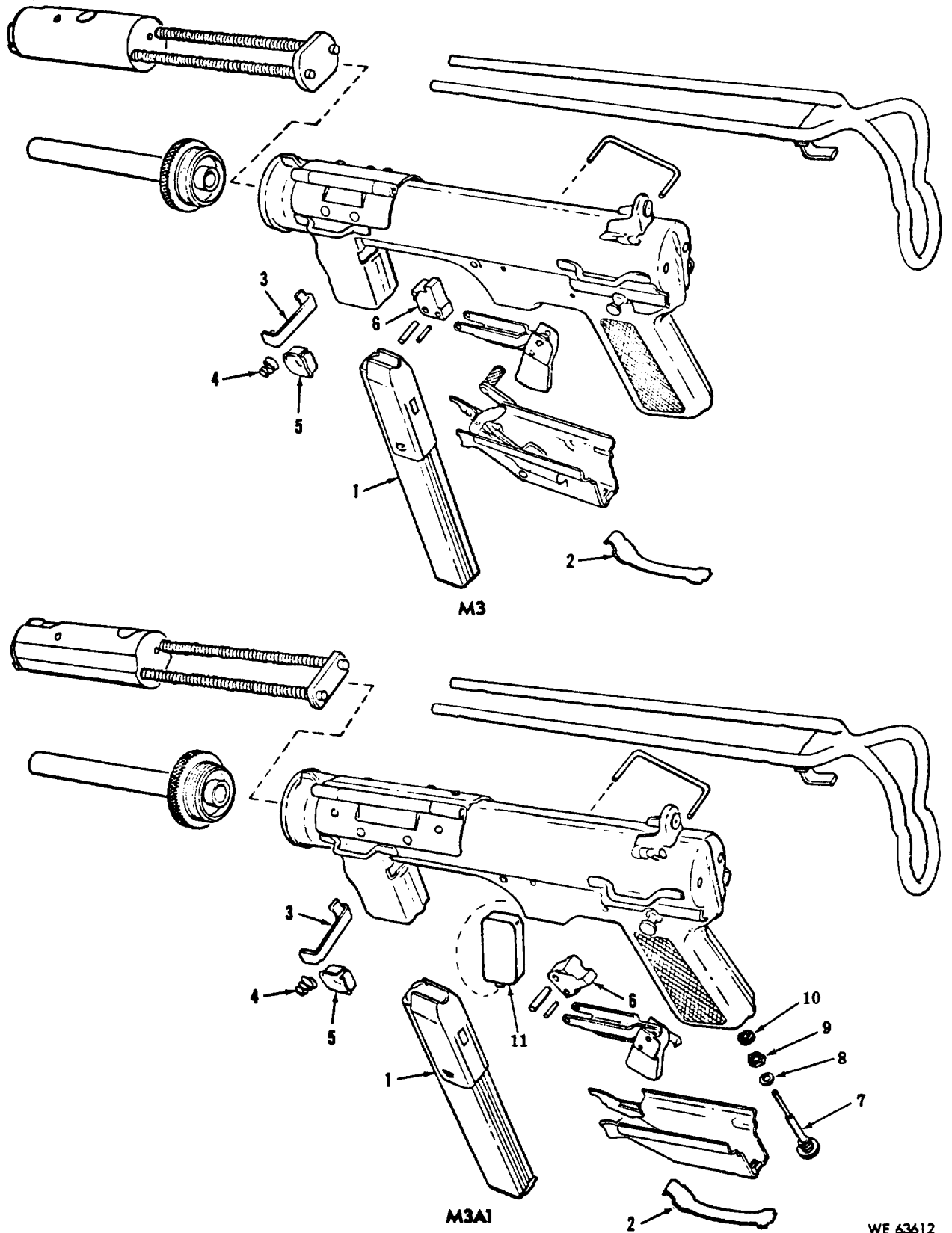

Figure C-1. Major groups assemblies and components—Caliber .45 Submachine Guns M3 and M3A1.

WE 63612

By Order of the Secretary of the Army:

JOHN A. WICKHAM, JR.
General, United States Army
Chief of Staff

Official:

ROBERT M. JOYCE
Major General, United States Army
The Adjutant General

Distribution: To be distributed in accordance with DA Form 12-40, Operator's and Organizational Maintenance Requirements for Submachine Gun, Caliber .45, M3, M3A1.

TECHNICAL MANUAL

No. 9-1005-229-12



HEADQUARTERS
DEPARTMENT OF THE ARMY
WASHINGTON, D. C., 20 October 1969

OPERATOR'S AND ORGANIZATIONAL MAINTENANCE MANUAL
INCLUDING REPAIR PARTS AND SPECIAL TOOLS LISTS

SUBMACHINE GUN, CALIBER .45: M3, W/E
(1005-672-1767)
SUBMACHINE GUN, CALIBER .45: M3A1 , W/E
(1005-672-1771)

This manual is current as of 1 October 1969

	Paragraphs	Pages
CHAPTER 1. INTRODUCTION		
Section I. General -----	1-1-1-3	1-1
II. Description and data -----	1-4-1-6	1-1
CHAPTER 2. OPERATING INSTRUCTIONS		
Section I. Controls -----	2-1	2-1
II. Operation under usual conditions -----	2-2-2-4	2-2, 2-3
III. Operation under unusual conditions -----	2-5-2-7	2-4
CHAPTER 3. OPERATOR AND ORGANIZATIONAL MAINTENANCE INSTRUCTIONS		
Section I. Service upon receipt of materiel -----	3-1	3-1
II. Repair parts, special tools and equipment -----	3-2-3-5	3-1
III. Lubrication instructions -----	3-6-3-7	3-1
IV. Preventive Maintenance checks and services -----	3-8-3-9	3-2
Section V. Troubleshooting -----	3-10	3-4
VI. Operators maintenance procedures-----	3-11-3-12	3-4-3-6
VII. Organizational maintenance procedures -----	3-13-3-14	3-8
CHAPTER 4. AMMUNITION -----	4-1	4-1
CHAPTER 5. DESTRUCTION TO PREVENT ENEMY USE-----	5-1	5-1
APPENDIX A. REFERENCE -----	A-1-A-3	A-1
APPENDIX B. MAINTENANCE ALLOCATION CHART		
Section I. Introduction -----	B-1-B-3	B-1
II. Maintenance allocation chart for Caliber .45 Submachine Guns M3 and M3A1 -----		B-2
APPENDIX C. ORGANIZATIONAL MAINTENANCE REPAIR PARTS AND SPECIAL TOOLS LIST		
Section I. Introduction -----	C-1-C-7	C-1-C-3
II. Basic issue items list (figs C1 and C3) -----		C-4
III. Maintenance and operating supplies -----		C-5
IV. Prescribed load allowance -----		C-6
V. Repair parts list-----		C-7
VI. Major groups, assemblies and component parts (fig C1)-----		C-11
Bolt and guide rod group (fig C2)-----		C-12
Oiler carbine (fig C3) -----		C-13
Special tools, test and support equipment (fig.C-3)-----		C-8
VII. Index-Federal stock number and reference number cross-reference to figure and item number -----		C-10

* This manual supersedes TM 9-1005-229-12P, 14 Dec 64 in its entirety.

CHAPTER 1

INTRODUCTION

Section I. GENERAL

1-1. Scope

This manual contains instructions for the operator and organizational maintenance of the Caliber .45, Submachine Guns, M3 and M3A1.

1-2. Forms and Records

a. General DA forms and procedures used for equipment maintenance will be only those prescribed in TM 38-750, Army Equipment Record Procedures.

b. Recommendations *for Equipment Publication Improvements*. Report of errors, omissions,

and recommendations for improving this publication by the individual user is encouraged. Reports should be submitted on DA Form 2028 (Recommended Changes to DA Publications) and forwarded direct to the Commanding General, U.S. Army Weapons Command, ATTN: AMSWE-SMM-P, Rock Island, Illinois 61201.

1-3. Administrative Storage

Refer to TM 740-90-1 for Administrative Storage.

Section II. DESCRIPTION AND DATA

1-4. General

The Submachine Guns, M3 (fig. 1-1) and M3A1 (fig. 1-2) are aircooled, blowback-operated, magazine-fed, automatic shoulder weapons. They are light, compact and rugged. The stock is one piece of formed steel rod which can be telescoped for ease of handling and the ends are drilled and tapped for usage as a cleaning rod. The stock can also be used as a disassembly tool or wrench and is made so it can be utilized to load the magazine. There is no provision for semi-automatic fire, however, because of the low cyclic rate of fire the operator can fire single shots through trigger manipulation. Both submachine guns are fed a magazine which has a capacity of 30 rounds. For convenience of maintenance, the weapons are divided into groups and assemblies which consist of magazine, barrel, gun stock extension, bolt and guide rod group, trigger housing group, trigger and sear group, and receiver assembly.

1-5. Difference Between Models

The Submachine Gun M3A1 is basically the same as the Submachine Gun M3; however, the difference in the two models is specified in a through c below:

a. The housing assembly M3A1 (fig. 1-3) has been changed in design to eliminate the retracting handle, spring, lever assembly, and oiler clip. It contains the ejector, which is secured to the housing by two rivets.

b. The bolts for the M3 and M3A1 vary in design as shown in figure 1-4. The M3A1 bolt contains a circular cut which permits the cocking of the weapon by retracting the bolt with the finger. It also contains an ejector groove extending the length of the bolt. This permits the removal of the bolt and guide rod group without necessitating the removal of the trigger guard and housing assembly from the weapon. The retracting lever pawl notch has been eliminated and a cover-hinge-rivet clearance slot has been added.

c. The receiver assembly M3A1 is designed to incorporate the oiler in the stock. The cover hinge is riveted and now is part of the receiver body.

1-6. Tabulated Data

Weight of M3 w/o	
magazine	-----8.0 lb
Weight of M3A1	
w/o magazine	-----7.8 lb
Weight of empty	
magazine	-----0.75 lb

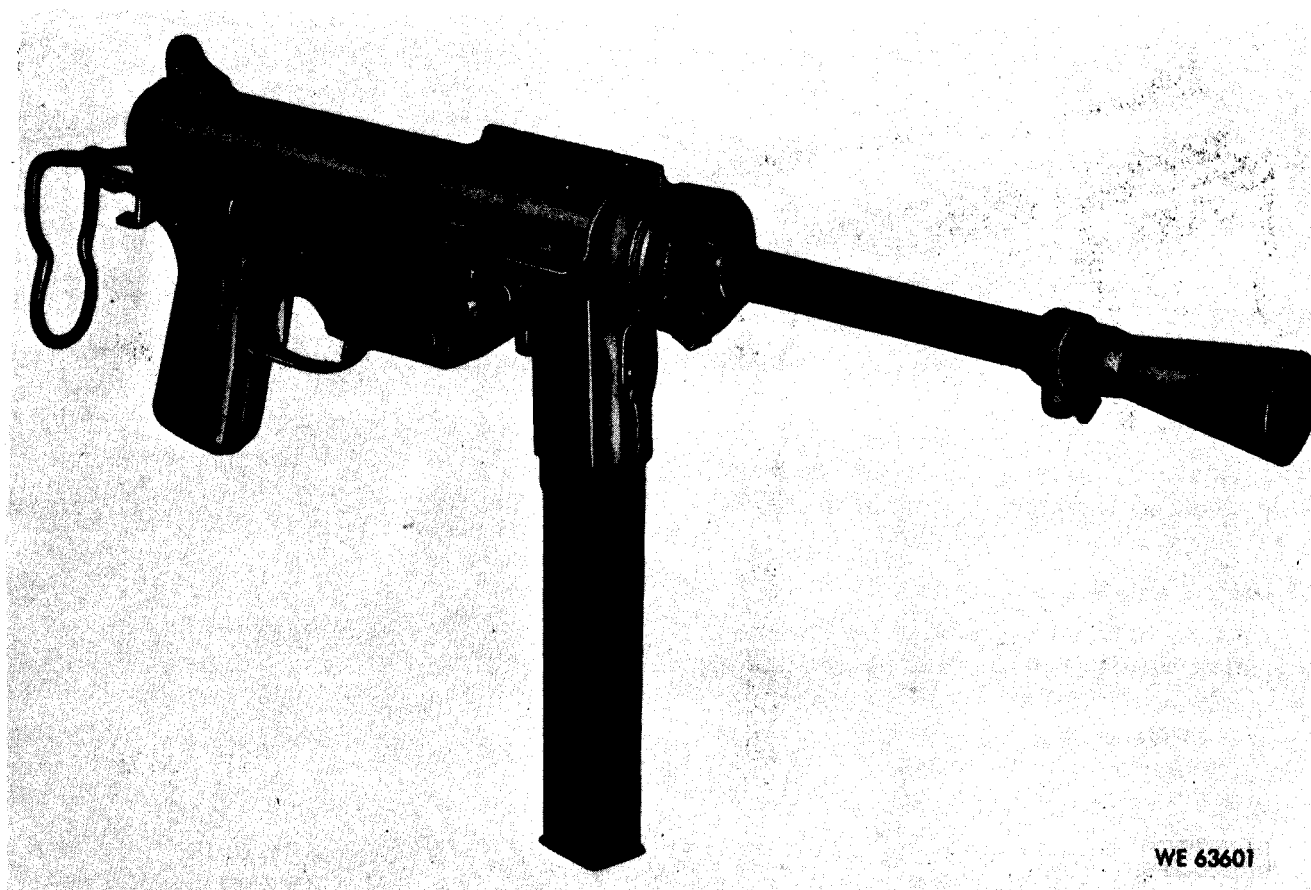

WE 63601

Figure 1-1. Calibm .45 Submachine Gun M3 w/Flash Hider Assembly, M9-right front view.

Weight of full magazine (30 rds) -----	2.10 lb	Sight radius -----	10.9 in
Length :		Trigger pull -----	4-1/2 to 7-1/2 lb
Stock Extended -----	29.8 in	Operation -----	Blowback
Stock Forward -----	22.8 in	Feed -----	Magazine (30 rd)
Barrel -----	8.0 in	Cooling -----	Air
Rifling:		Type of Ammunition -----	Ball, Tracer, Dummy
Number of lands -----	4.0	Rate of Fire -----	350 to 460 @s/m
Uniform right hand twist one turn in -----	16.0 in	Muzzle Velocity (Ball 234 grain Bullet) -----	920 FPS
Capacity of magazine -----	30.0 rd	Maximum Range (Ball 30° elevation) -----	760 yd or 1609 meters

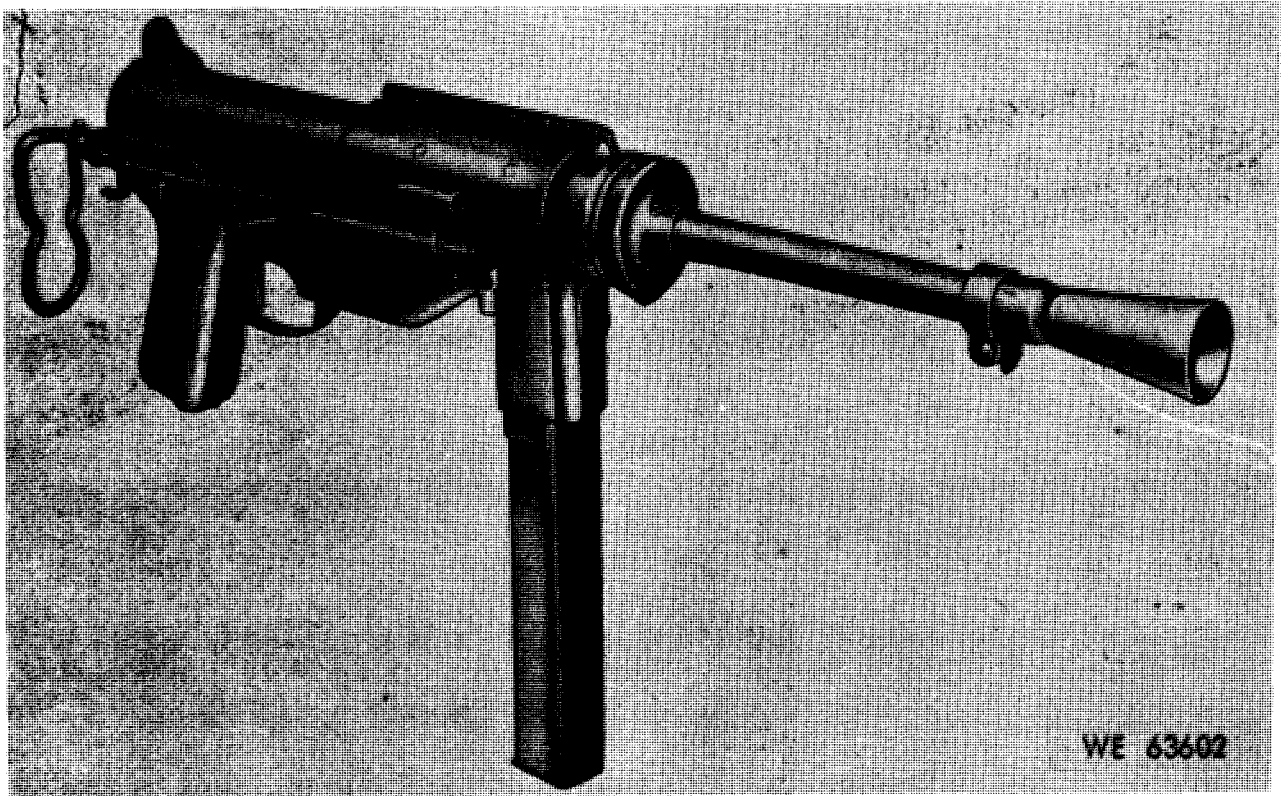

Figure 1-2 Caliber .45 Submachine Gun M3A1 w/Flash Hider Assembly, M9-right front view.

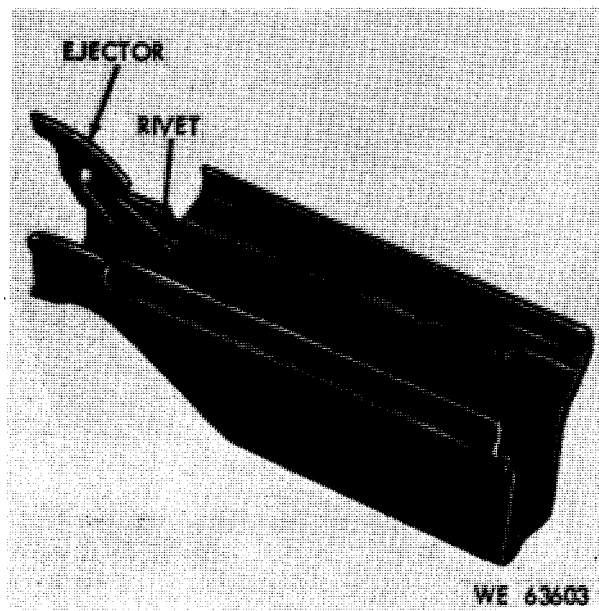

Figure 1-3. M3A1 housing assembly.

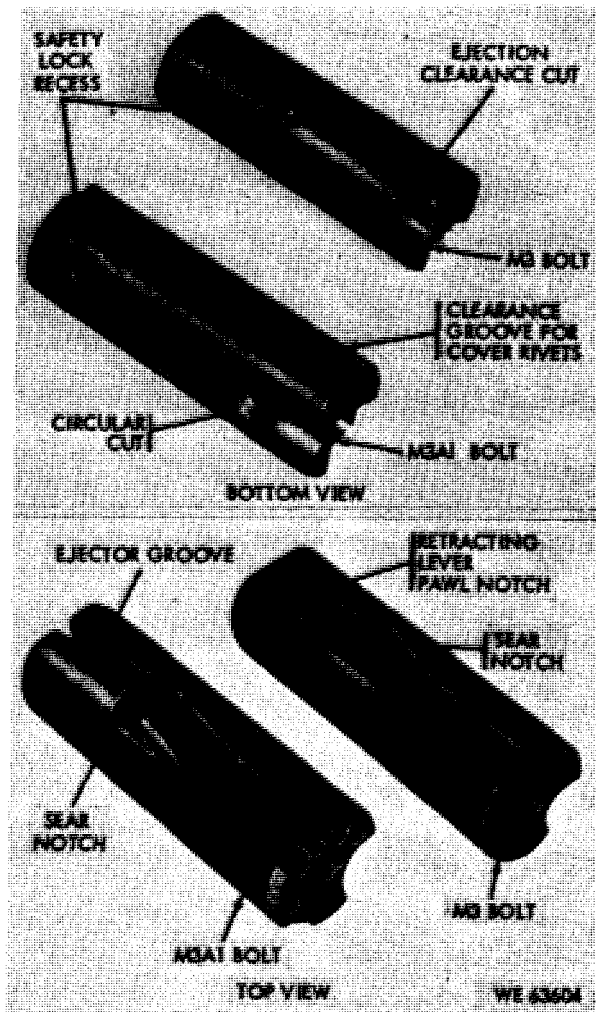

Figure 1-4. Two types of bolts.

CHAPTER 2

OPERATING INSTRUCTIONS

Section I. CONTROLS

2-1. General

to insure the proper operation of the Submachine Guns, Caliber .45, M3 and M3A1.

a. This section describes the various controls and provides the operator sufficient information

Table 9-1. Controls

Control of instrument	Function	Reference
Magazine release catch	When depressed, releases the magazine for loading and unloading.	Fig 2-1
Stack extension catch	When depressed, releases the stock extension.	Fig 2-1
Safty	When cover is closed, prevents firing of weapon.	Fig 2-2
Trigger	Controls firing of weapon.	Fig 2-1

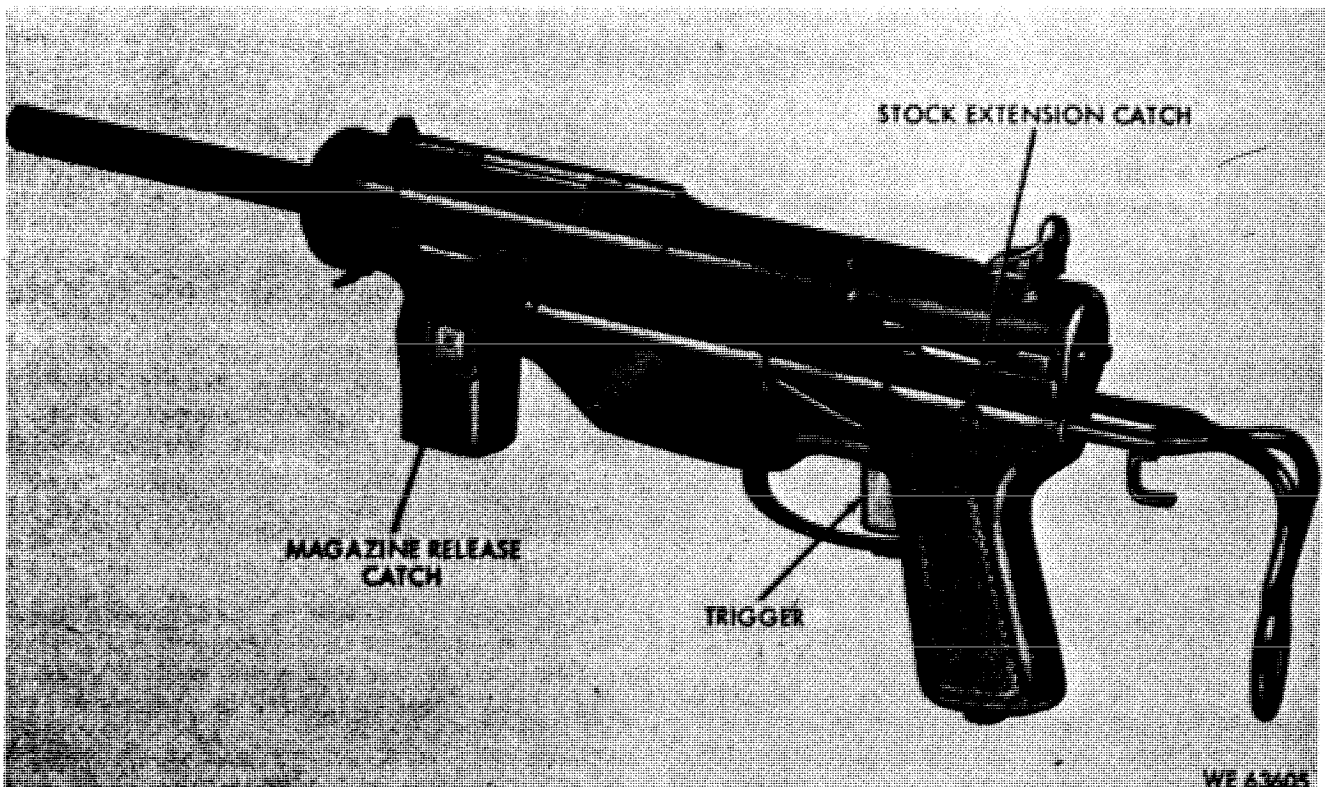
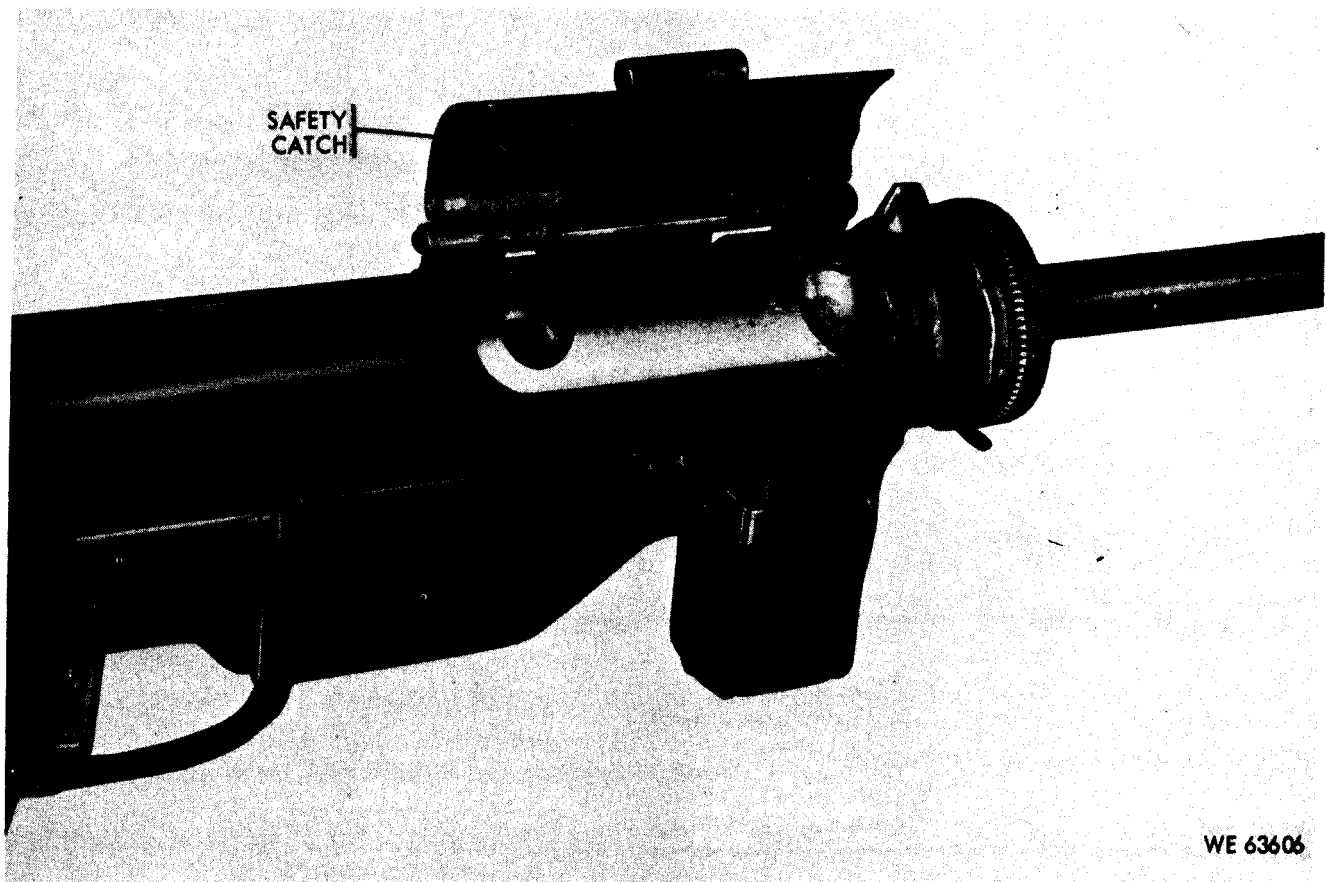

Figure 2-1. Controls.



WE 63606

Figure 2-2. Controls.

Section II. OPERATION UNDER USUAL CONDITIONS

2-2. General

Care and cleaning of the submachine gun includes daily preventive maintenance, which is the ordinary care of the weapon to preserve its condition and appearance when no firing is done. Before firing cleaning insures that the weapon is safe to fire and is properly lubricated for efficient operation and after firing maintenance insures that all corrosion-inducing agents are completely removed. For cleaning procedures refer to paragraph 3-12. For lubrication procedures refer to paragraphs 3-6 and 3-7.

2-3. Loading, Firing and Unloading

a. Loading Magazine. Use the stock extension as a hand loader. Place the butt of stock on top of the magazine, then place the base of the magazine on a firm surface. Push down on the stock extension to depress the magazine follower. Insert a cartridge, base first, into the magazine. Lift the stock extension and push the cartridge all the way into the magazine. Push down on the

stock extension, depressing the cartridge and magazine follower (fig. 2-3). Repeat the operation until the magazine is full.

b. Loading Submachine Gun.

Warning. Care must be exercised to either have the submachine gun raised or pointed down range when loading.

To load the submachine gun, pull the bolt sharply to the rear (cock), close the cover (lock), insert the magazine, and push it upward until the magazine catch clicks into the magazine notch (load).

c. Firing.

Warning. The firer must be sure that the bore of the submachine gun is free from any obstruction in the bore that will result in damage to the weapon and possible injury to personnel.

To fire the weapon, raise the cover and pull the trigger. The weapon has no mechanism for semi-automatic fire. However, it is possible to fire sin-

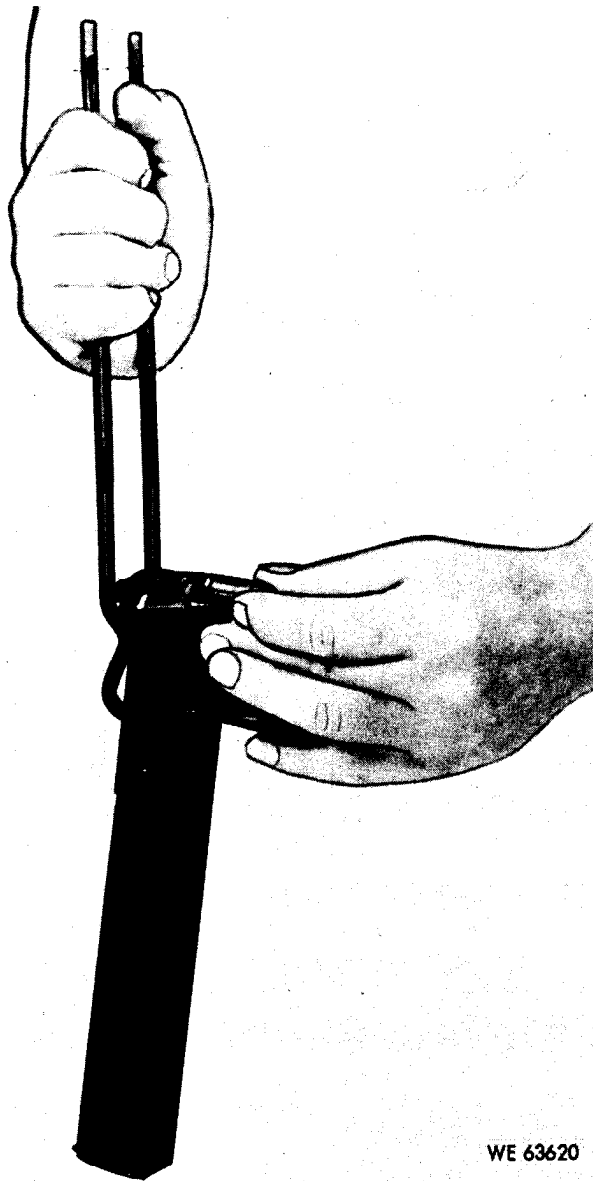

Figure 2-3. Loading magazine.

gle shots by proper functioning of the trigger, pressing it and then quickly releasing it. It takes practice for a firer to become proficient at firing single shots. When the magazine has been emptied, the bolt will close on the empty chamber. Cock the weapon and close the cover, before inserting another loaded magazine.

Warning. Always keep the cover closed as it locks the bolt either forward or backward and functions as a safety. The submachine gun has no mechanical means of locking the trigger. The insertion of a loaded magazine loads the gun. If the cover is open and the bolt cocked, pressure on the trigger will fire the gun. If an unlocked gun is dropped, it may fire whether the

bolt is cocked or not. When firing long bursts, the weapon has a tendency to move up and to the right. The firer can control this tendency by always taking a correct firing position.

d. Unloading. Remove the magazine, and raise the cover. If the bolt is forward, pull it to the rear. Inspect the chamber (look and feel). Press the trigger and allow the bolt to go forward, then close the cover. At this time the weapon is clear.

2-4. Firing Malfunctions and Stoppages

a. Malfunctions. A malfunction is a failure of the weapon to function properly. Malfunctions are classified as defects in the weapon that normally do not cause a break in the cycle of operation.

(1) Sluggish operation of the weapon is usually due to excessive friction caused by dirt, lack of proper lubrication, burred or bent guide rods, or a dent in the receiver. See table 3-3, trouble-shooting.

(2) Uncontrolled automatic fire (runaway gun) is fire that continues after the trigger has been released. This may be caused by the following:

- (a) A worn sear nose
- (b) A worn sear notch on the bolt
- (c) A weak or broken trigger spring

b. Stoppage. A stoppage is an unintentional interruption in the cycle of operation. A stoppage occurs when the submachine gun does not fire when the trigger is squeezed through no fault of the firer. Periodic inspection and proper care and cleaning will reduce the possibility of the submachine gun having a stoppage.

c. Immediate Action in Case of Failure to Fire.

(1) As the first step in reducing a stoppage, remove the magazine, retract the bolt, and inspect the chamber to insure that it does not contain a live cartridge or any other obstruction. If there is no obstruction, close the cover, replace the magazine, open the cover, and attempt to fire. If weapon still does not fire, check to see whether a live cartridge has chambered; if it has not, remove the magazine and insert a new magazine.

(2) If there is a live cartridge or other obstruction lodged in the chamber, cock the weapon and hold the cover down firmly; remove the barrel; then clear the chamber by using the stock to push the obstruction out of the barrel.

Note. Under combat conditions, when time is short, omit the step of removing the barrel.

Section III. OPERATION UNDER UNUSUAL CONDITIONS

2-5. General

In addition to the normal operation of the submachine gun, special care in cleaning and lubrication must be observed where extremes of temperature, humidity, and atmospheric conditions exist or are anticipated. Proper cleaning, lubrication, storage and handling of lubricants not only insure operation of the weapon, but also guard against wear of the working parts and deterioration of the materiel.

2-6 Operation in Extreme Cold

Note. Use general purpose lubricating oil (PL special) to lubricate all component of the weapon when temperature is expected to vary down to -30°F temporarily. When temperature is expected to remain at 0°F to 46°F weapon will be lubricated with weapons lubricating oil (LAW) after cleaning.

a. It is necessary that the moving park of the weapon be kept absolutely free from moisture. Excessive oil on the working parts will solidify and cause sluggish operation or complete failure,

(1) Before firing in temperatures below 0° Fahrenheit, disassemble the weapon and clean all parts thoroughly. Oil parts lightly by rubbing with a cloth dipped in weapons lubricating oil (LAW). Keep the bore and chamber free of oil.

(2) When the weapon is brought indoors, allow it to come to room temperature; then disassemble it, wipe it completely dry of any moisture,

clean and oil lightly with weapons lubricating oil (LAW).

(3) If the submachine gun has been fired, the bore should be immediately swabbed out with an oily patch. When the weapon reaches room temperature, clean and oil as prescribed in paragraphs 3-6, 3-7 and 3-12.

2-7. Operation in Extreme Heat

a. In tropical climates where temperature and humidity are high or where salt air is present, and during rainy seasons, thoroughly inspect the weapon daily and keep lightly oiled when not in use. Remove the groups at regular intervals and, if necessary, disassemble them for cleaning, drying and oiling. Be careful to see that all unexposed parts, as well as exposed surfaces, are kept clean and oiled with general purpose lubricating oil (PL special).

b. In hot, dry climates, where sand and dust are likely to get into the trigger housing, receiver, and bore, the weapon should be wiped clean daily, or more often if necessary. Groups should be disassembled to insure thorough cleaning. Immediately after use in sandy terrain, the weapon should be cleaned and lubricated with PL special. Lubricants should be wiped from exposed and noncritical operating surfaces. This will prevent sand or dust from sticking to the lubricants and forming an abrasive which can damage the moving parts.

CHAPTER 3

OPERATOR AND ORGANIZATIONAL MAINTENANCE INSTRUCTIONS

Section I. SERVICE UPON RECEIPT OF MATERIEL

3-1. General

Refer to table 3-1.

Table 3-1. Service Upon Receipt of Materiel

Step	Action	Reference
1	Remove submachine gun and items from container.	
2	Remove VCI packaging.	
8	Check for missing items.	
	Note. Items must agree with Basic Issue Items List.	App C
4	Field strip weapon and inspect for:	Para 3-11
	Missing parts	App C
	Proper assembly	
5	Clean and lubricate (if necessary).	Para 3-12, 3-6 and 3-7
6	Assemble	Figs 3-1 and 3-2
7	Hand function	

Section II. REPAIR PARTS, SPECIAL TOOLS AND EQUIPMENT

3-2. Repair Parts

Repair parts issued with the submachine guns are listed in appendix C.

3-3. Tools and Equipment

Tools and equipment issued with the submachine guns are listed in the basic issue items list, appendix C.

3-4. Special Tools and Equipment

Tools and equipment for organizational maintenance are listed in and illustrated in appendix C.

3-5. Maintenance Repair Parts

Organizational maintenance repair parts are listed in and illustrated in appendix C.

Section III. LUBRICATION INSTRUCTIONS

3-6. General Lubrication instructions

a. Use PL special for lubrication above 0°F, and LAW for lubrication below 0°F on all parts of the weapon. All interior parts that do not come in contact with the ammunition must have a light coat of oil prior to firing.

b. Refer to appendix C for listing of maintenance supplies.

3-7. Specific Lubrication instructions

Apply a light coat of PL special, before firing, to the guide rods. During lulls in firing lubricate the guide rods, oil the sear pin and trigger pin.

Caution. Prior to loading the weapon, after lubrication, attention should be directed to wiping all excess oil off the receiver; Excessive oil could cause loss of control during firing.

Section IV. PREVENTIVE MAINTENANCE CHECKS AND SERVICES

3-8. Preventive Maintenance Performed by the Operator

maintenance checks and services to be performed by the operator.

a. The submachine gun should be inspected (para 3-12b) each day and cleaned (para 8-12a), if necessary.

3-9. Preventive Maintenance Performed by Organizational Maintenance

b. Refer to table 3-2 for specific preventive

Refer to table 3-2.

Table 3-2. Preventive Maintenance Checks and Services

Item number	Interval						Item to be inspected	Procedure	Reference
	Operator Org								
	Daily								
	B	D	A	W	M	Q			
1	1						<p>Warning. Before starting an inspection, be sure to clear the weapon. Do not actuate the trigger until the weapon has been cleared. Remove magazine, inspect the chamber to insure that it is empty and check to see that no ammunition is in position to be introduced.</p> <p>Examine exterior for damage (i.e., dents, broken or missing parts).</p> <p>Open cover and check for freedom of bolt assembly movement within the receiver. With bolt to the rear, close cover and squeeze the trigger; bolt should not go forward. Open cover, squeeze trigger, sear should disengage allowing bolt to move forward. If submachine gun malfunctions during use or becomes otherwise unserviceable turn the gun into organizational maintenance.</p> <p>Field strip weapon to clean and lubricate.</p> <p>Inspect exterior of tube for deformities. Push down on follower and inspect tube interior for dirt and/or debris.</p> <p>Check barrel interior for obstruction. Examine exterior for extrusions that would indicate a bulged barrel. Clean as required.</p> <p>Inspect for presence of all components. Examine extractor for breakage. Inspect for freedom of movement on the guide rods.</p> <p>Inspect for deformities and for freedom of movement of the trigger. Examine the ejector for breakage.</p> <p>Reassemble weapon and wipe the external surface with a lightly oiled patch.</p> <p>Check barrel locking spring for retention of barrel to receiver. Do not attempt to bend spring.</p> <p><i>Note.</i> During periods of inactivity, perform above services every 90 days, unless inspection reveals more frequent servicing is necessary.</p>		
2	2					Submachine Guns (M3 and M3A1)			
3	3								
4	4								
5		5							
6			6						
7			7			Magazine assembly			
8			8			Barrel			
9			9			Bolt and guide rod group			
10			10			Trigger housing group			
11			11						
12			12			Receiver assembly			

Section V. TROUBLESHOOTING

3-10. General

a. Refer to table 3-3.

Note. The letters in the maintenance level column indicate the lowest level of maintenance at which corrective

action can be performed Letter C indicates operator and letter O organizational maintenance.

b. Notify organizational maintenance for corrective action not authorized to the operator.

Table 3-3. Troubleshooting

Malfunction	Probable cause	Corrective action	Maintenance level
1. Failure to feed.	a. The top cartridge in the magazine is not properly positioned.	a. Reload magazine.	c
	b. Improper assembly of magazine.	b. Reassemble magazine (fig 3-3).	c
	c. Dirty or dented magazine.	c Replace magazine.	c
	d. Weak or broken magazine spring.	d. Clean or replace magazine.	c
	e. Worn magazine notch.	e. Replace magazine.	c
	f. Corroded ammunition.	f. Replace ammunition.	c
	g. Worn or broken magazine catch.	g. Replace magazine catch.	o
2. Failure to chamber	a. Dirty chamber.	a. Clean chamber (para 3-12).	c
	b. Obstruction in chamber.	b. Remove obstruction.	c
	c. Weak driving springs.	c. Replace springs.	o
3. Failure to fire	a. Defective ammunition.	a Replace ammunition.	c
	b. Defective firing pin.	b. Evacuate to direct support maintenance.	o
	c. Weak or broken driving spring.	c. Replace driving springs.	o
	d. Dirt on face of bolt.	d. Clean (para 3-12).	c
4. Failure to extract	a. Worn or broken extractor.	a. Replace extractor.	o
	b. Dirty chamber.	b. Clean chamber (Para 3-12).	c
	c. Pitted chamber.	c. Evacuate to direct support maintenance.	o
5. Failure to eject.	a. Broken ejector.	a. Evacuate to direct support support maintenance.	o
	b. Broken or missing extractor.	b. Replace extractor.	o
	C. Lack of lubrication.	c. Lubricate (Para 3-6).	c
6. Failure to cock	a. Chipped or worn sear.	a. Replace sear.	o
	b. Worn sear notch.	b. Evacuate to direct support maintenance.	o
7. Miscellaneous Excessive pull required to retract bolt.	c. Bent guide rods.	c. Straighten rods.	o
	Lack of lubrication.	Lubricate (Para 3-6).	c

Section VI. OPERATORS MAINTENANCE PROCEDURES

3-11. Disassembly/Assembly Procedures
For disassembly/assembly of the weapon authorized to the operator refer to figures 4-1 and 3-2.

Note. White arrows, shown on illustrations, indicate removal or disassembly sequence, and black arrows assembly or installation sequence.

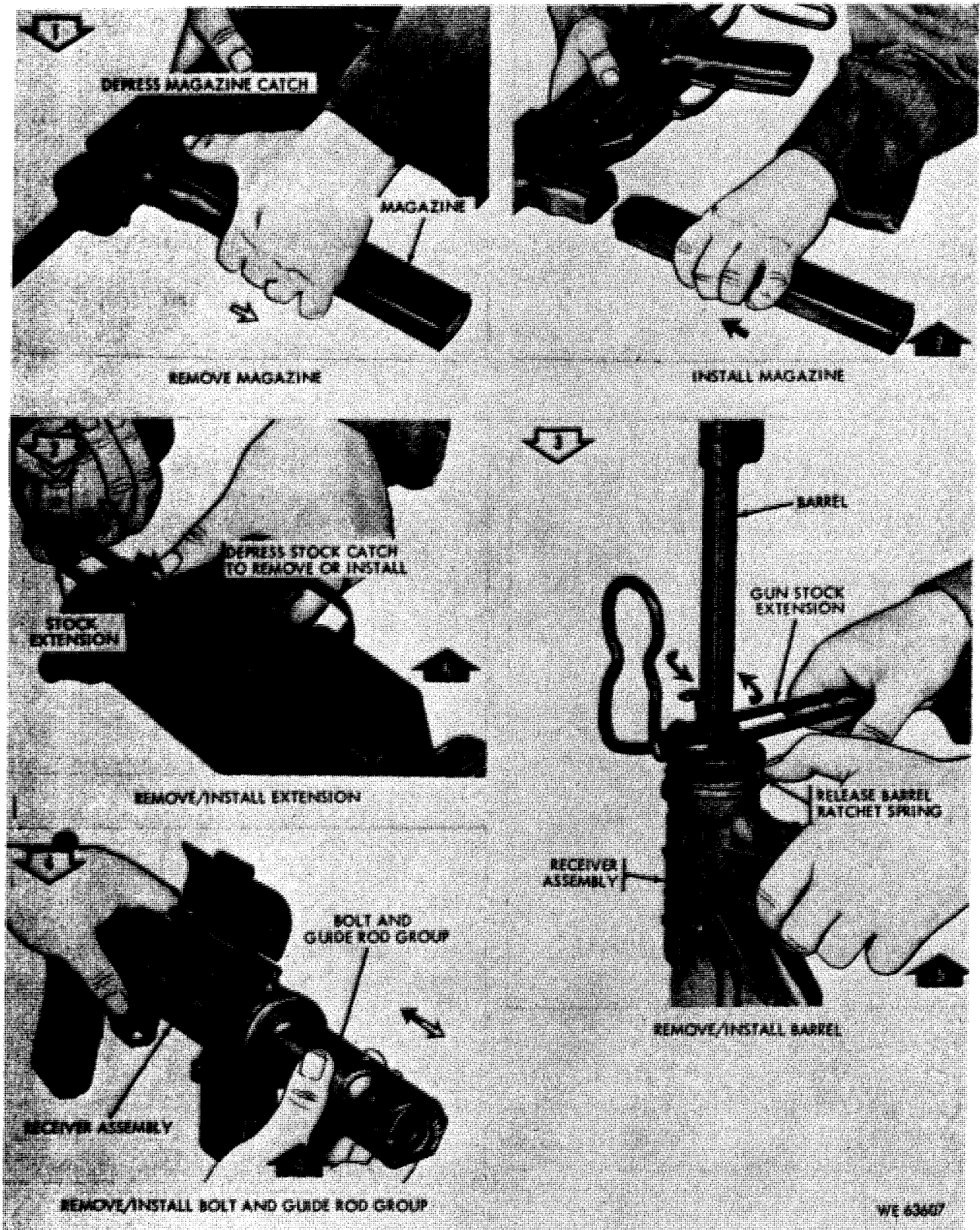
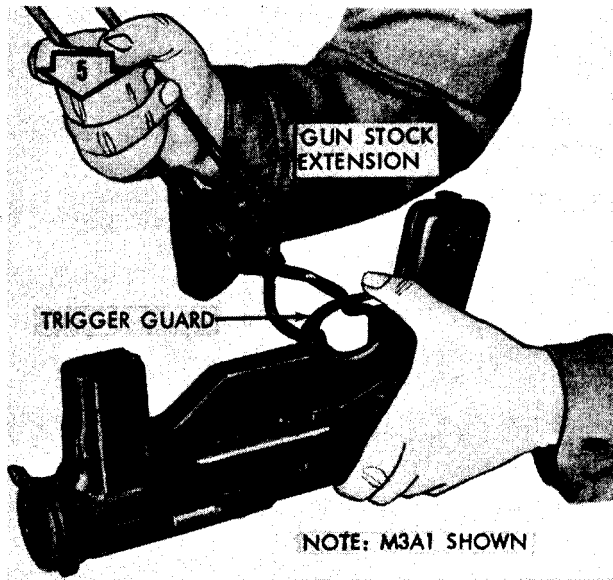
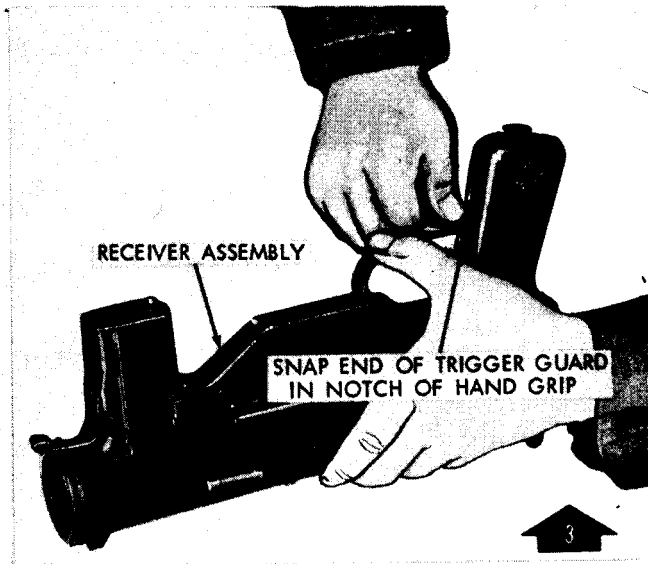

Figure 3-1. Disassembly/assembly of Submachine Guns M3 and M3A1. (1 of 2)



REMOVE TRIGGER GUARD



INSTALL TRIGGER GUARD

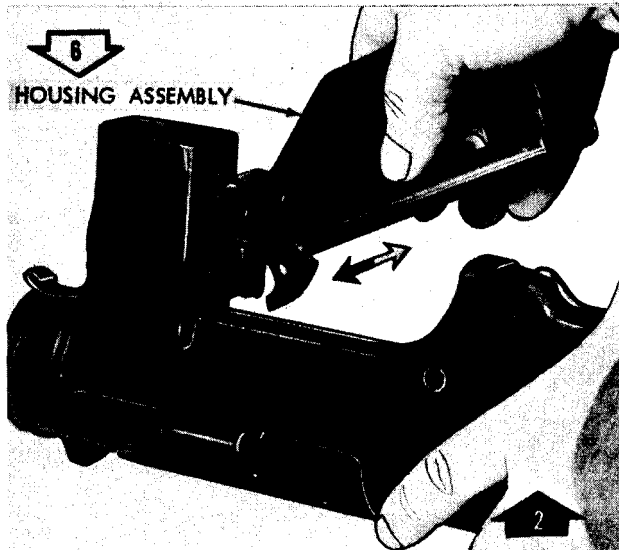

REMOVE/INSTALL HOUSING ASSEMBLY

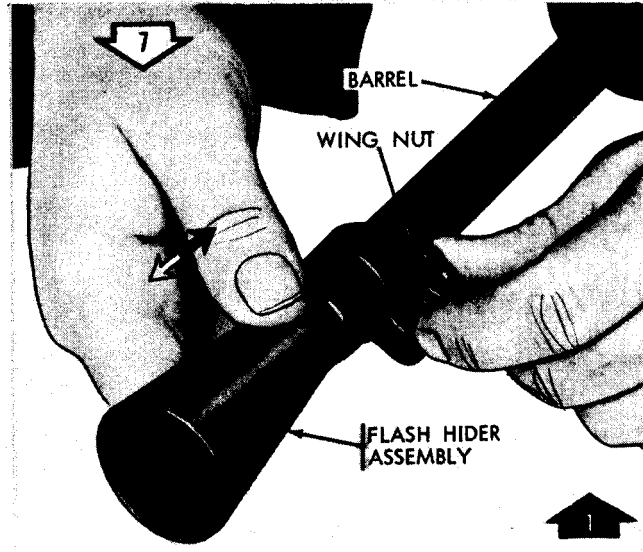

REMOVE/INSTALL FLASH HIDER ASSEMBLY

WE 63608

Figure 3-2. Disassembly/assembly of Submachine Guns M3 and M3A1. (2 of 2)

3-12. Cleaning, Inspection, and Repair

a. Cleaning.

Note. Use general purpose lubricating oil (PL special) to lubricate all components of the weapon when temperature is expected to vary down to -30°F temporarily. When temperature is expected to remain at 0°F to -65°F weapon will be lubricated with weapons lubricating oil (LAW) after cleaning.

(1) *Cleaning before firing.* Before the submachine gun is fired, the following steps should be taken to make sure that it will function properly:

(a) Disassemble the weapon (figs 3-1 and 3-2).

(b) Clean the bore and chamber with a clean, dry patch,

Note. Do not apply oil to the bore or chamber before firing.

(c) Clean all parts thoroughly.

(d) Use a lightly oiled cloth to apply a light coat of oil to all parts that do not come in contact with the ammunition. Apply a light coat of PL special to the guide rods.

(e) Assemble the weapon (figs. 3-1 and 3-2) .

(f) Wipe excess oil from the receiver.

(g) Clean the magazine and place a light film of oil on outer surfaces.

(2) *Cleaning during firing.*

(a) During lulls in firing, lubricate the guide rods, sear pin, and trigger pin. Use the stylus of the oiler to apply oil from the oiler.

(b) If time permits, during a lull in firing, disassemble the submachine gun and oil the sear, sear notch, connector pin, connector rivet, and the grooves in the bottom of the bolt.

(3) *Cleaning after firing.* The weapon must be cleaned as soon as practicable on the day of firing and for the next three days, or longer if necessary, in the following manner:

(a) Disassemble the groups.

(b) Clean all parts with dry, clean cloth, using riflebore cleaning compound (CR) if necessary. Inspect all parts and apply a light film of oil.

(c) Clean the bore and chamber, using the following procedure:

1. Saturate a patch with CR, and run it back and forth through the bore.

2. Repeat the operation two or three times with clean patches saturated with CR.

3. Run dry patches through the bore until they come out dry and clean.

4. Inspect the bore for cleanliness. If it is not free of all residue, repeat the cleaning pro-

cess. If the residue cannot be removed by the use of patches, the bore brush should be used,

5. Clean the chamber with CR applied to a patch on the chamber cleaning brush.

6. Dry the chamber and inspect it for cleanliness.

7. When the chamber and bore are thoroughly clean, lubricate with general purpose lubricating oil (PL special).

b. Inspection.

Warning. Clear the weapon of all ammunition before starting the inspection. Remove the magazine and check the chamber to insure it is empty. Do not actuate the trigger until the weapon has been cleared.

The operator should daily inspect the weapon. Particular attention should be directed to making sure the submachine gun is free from rust and foreign matter, and that it is clean.

c. Repair.

(1) Operator's repairs to the weapon will be limited to the replacement of the magazine. The magazine can be disassembled in accordance with figure 3-3 for cleaning purposes.

Note. On the new magazines the base of the magazine is spot-welded to the body and disassembly of the magazine by the operator for cleaning purposes is not authorized.

(2) For repairs other than authorized above, notify organizational maintenance,

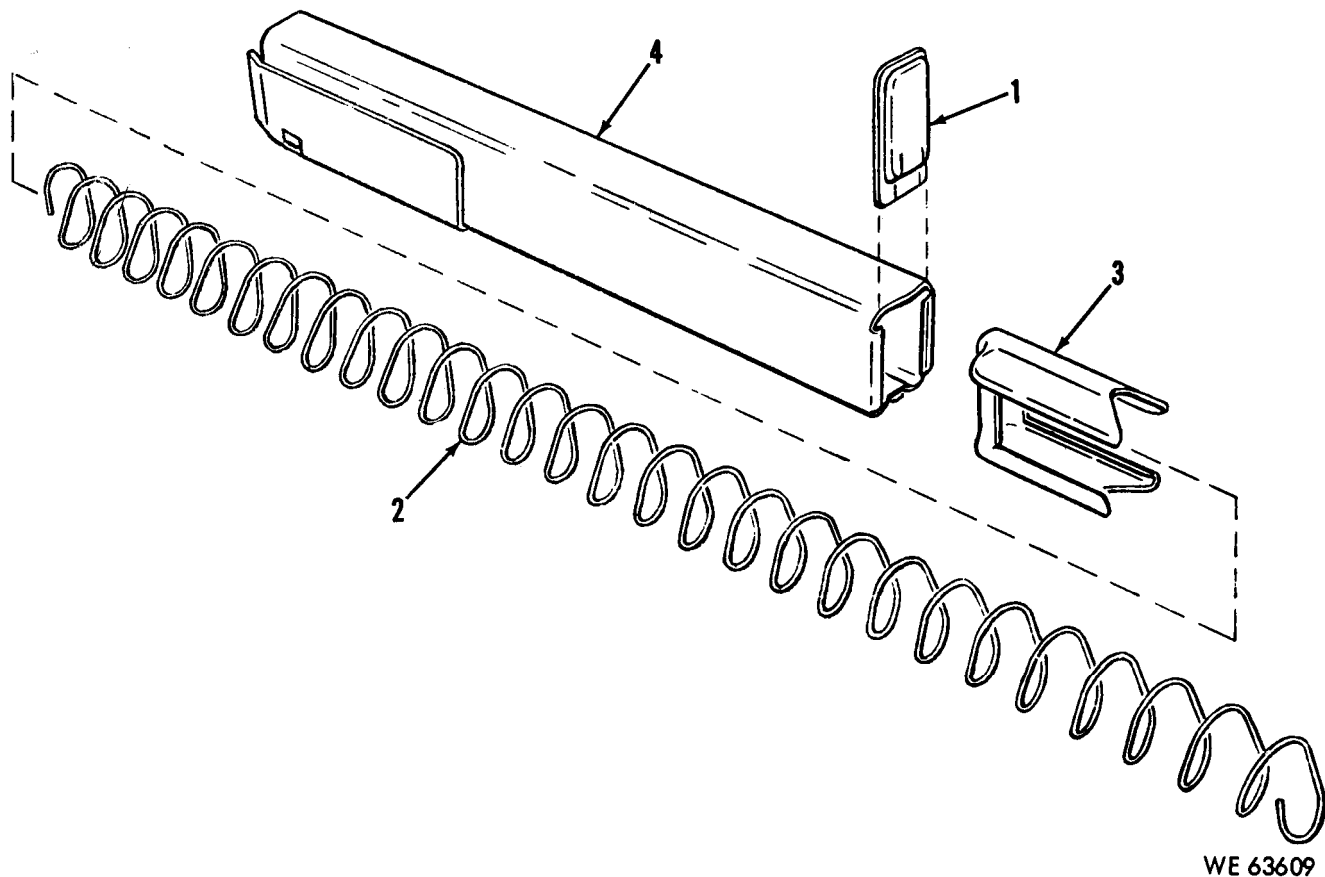

WE 63609

Figure 3-3. Magazine-exploded view.

Section VII. ORGANIZATIONAL MAINTENANCE PROCEDURES

3-13. Disassembly/Assembly Procedures

Refer to figures 3-1 through 3-5 for detailed procedures on disassembly/assembly of the sub-machine gun.

3-14. Cleaning, Inspection, and Repair

a. Cleaning. For general cleaning instructions refer to TM 9-208-1 and TM 9-247. For specific cleaning procedures refer to paragraph 3-12(a). On those component parts which contain a hard carbon residue it may be necessary to clean the parts with carbon removing compound, P-C-111. Observe the following procedures when using P-C-111,

Warning. Avoid skin contact with P-C-111. The compound should be washed off thoroughly with running water if it comes in contact with the skin. A good lanolin base cream, after exposure to the compound, is helpful. The use of

rubber gloves and protective equipment is recommended.

(1) Using a suitable container, fill with fresh compound.

(2) Before soaking parts in the compound, remove all loose dirt, grease, and oil. Place parts to be cleaned in the container, making certain they are completely immersed.

(3) Depending on the amount of residue to be removed, soak for 2 to 16 hours.

(4) Rinse parts with water or dry cleaning solvent (SD), and brush with a stiff bristle brush.

(5) Wipe parts dry and lubricate (para 3-6 and 3-7).

b. Inspection.

Refer to table 3-4, for inspection procedures.

c. Repair.

(1) Remove burs, rough spots, rust and scored areas with a fine stone or crocus cloth

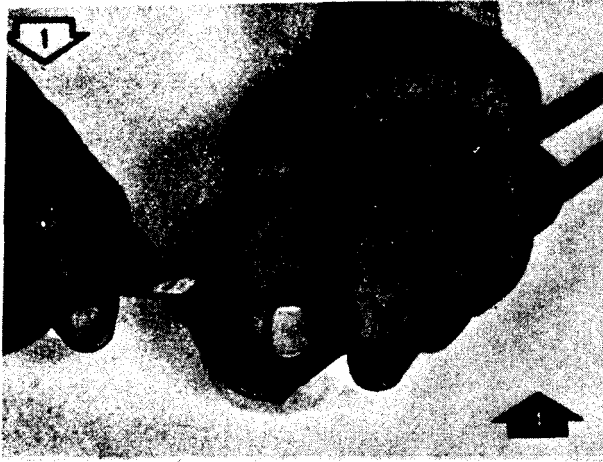

REMOVE/INSTALL RETAINING CLIP.

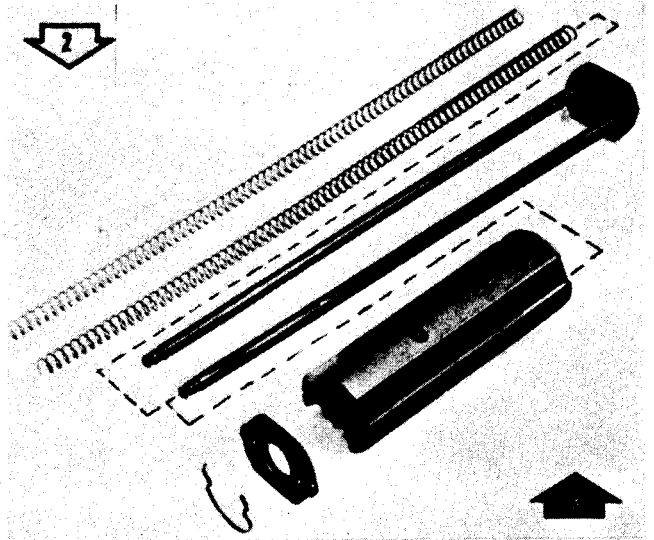

DISASSEMBLE/ASSEMBLE BOLT AND GUIDE ROD GROUP.

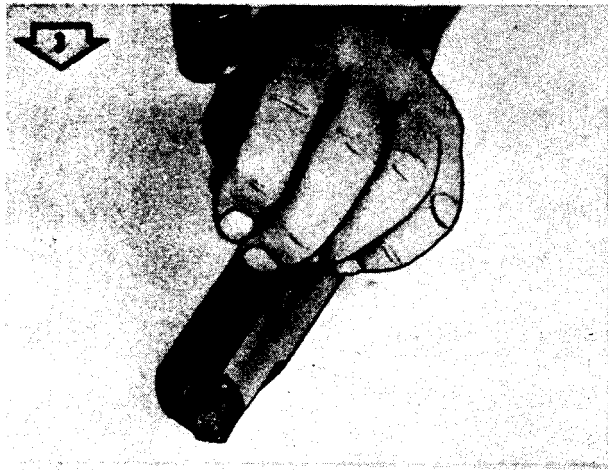

REMOVE SHOULDER PIN.



INSTALL SHOULDER PIN.

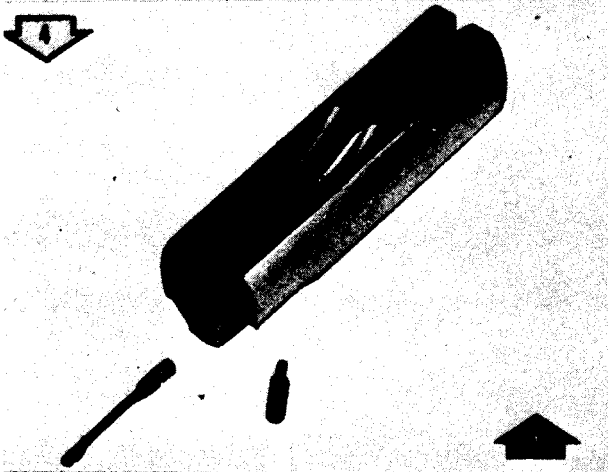

REMOVE/INSTALL EXTRACTOR.

WE 63610

Figure 3-4. Disassembly/assembly of bolt and guide rod group.



Figure 3-5. Remove/install trigger and sear group, magazine catch, spring and shield.

moistened with oil. When stoning, care must be taken not to alter any surfaces from the original dimensions.

(2) Replace only those parts which are authorized to organizational maintenance. (Refer to appendix C).

(3) For repair or replacement of parts, not authorized for organizational maintenance, evacuate submachine gun to direct support maintenance.

(4) For specific repair functions refer to table 3-4.

Table 3-4. Inspection and Repair Procedures

Component part or assembly	Inspection	Repair	Reference
Magazine	<p>Depress follower and spring to check freedom of movement.</p> <p>With follower depressed check for dirt or foreign material that could impede functioning.</p> <p>Inspect tube for dents.</p> <p>Inspect magazine lips for burs and/or deformation.</p>	<p>Clean, lubricate or replace magazine.</p> <p>Clean and lubricate.</p> <p>Replace magazine.</p> <p>Remove burs or replace magazine.</p>	<p>Para 3-12 and 3-6</p> <p>Para 3-12 and 3-6</p> <p>Fig 3-1</p>
Barrel	<p>Inspect barrel assembly for looseness of retaining pin.</p> <p>Inspect barrel assembly for burred or damaged threads.</p> <p><i>Note.</i> The barrel assembly, previously used on the M3, has been changed in design by the addition of two flat cuts on the barrel collar to permit the usage of the stock as a wrench for removal and installation of the barrel assembly. The unnotched barrel is still usable.</p>	<p>Evacuate to direct support maintenance.</p> <p>Remove burs or evacuate to direct support maintenance.</p>	<p>Para 3-14c</p>
Gun stock extension	<p>Inspect for distortion.</p> <p>Inspect for magazine loading assist. (Original M3 extension did not incorporate assist but is acceptable, if serviceable.)</p> <p><i>Note.</i> The gun stock extension previously used on the M3, has been changed in design by the addition of a bracket at the rear end. This bracket is utilized as a hand loader for loading ammunition into the magazine and to provide a stop for limiting the entry of the stock into the barrel when the stock is used as a cleaning rod, thereby preventing burring the end of the barrel. However, the old gun stock extension is still usable.</p>	<p>Repair or replace.</p> <p>Replace extension.</p>	<p>Fig 3-2</p>
Bolt and guide rod group	<p><i>Note.</i> On the guide rods that contain a round plate (early manufacture) it will be necessary to remove the trigger guard and housing assembly before removal of bolt and guide rod group.</p> <p>Inspect guide rods for distortion restricting movement of the bolt.</p> <p>Inspect helical spring for flat worn areas, kinks or distortion.</p> <p>Inspect retaining clip for retentive qualities.</p> <p>Inspect extractor claw for burs or damage.</p> <p>Inspect bolt for burs.</p> <p>Inspect firing pin in the face of the bolt for wear or peening.</p> <p><i>Note.</i> Bolt for M3A1 must show two holes on side of the bolt.</p>	<p>Remove restriction by stoning or evacuate to direct support maintenance.</p> <p>Replace spring.</p> <p>Replace clip.</p> <p>Repair or replace.</p> <p>Remove burs.</p> <p>Evacuate to direct support maintenance.</p>	<p>Fig 3-4</p> <p>Fig 3-4</p> <p>Fig 3-4</p>

Table 3-4. Inspection and Repair Procedures—Continued

Component part or assembly	Inspection	Repair	Reference
Trigger housing group	<p>Inspect trigger guard for damage that would retard retention of the trigger housing to the receiver.</p> <p>Inspect ejector for damage.</p> <p>Inspect handle for freedom of movement. (Handle retraction must move lever assembly forward and backward.) (M3 only).</p> <p>Inspect housing for dents and/or deformities.</p>	<p>Replace guard.</p> <p>Evacuate to direct support maintenance.</p> <p>Evacuate to direct support maintenance.</p> <p>Evacuate to direct support maintenance.</p>	Fig 3-2
Trigger and sear group	<p>Inspect trigger for burrs that would impede operation.</p> <p>Inspect sear for rounded lip.</p>	<p>Remove burrs.</p> <p>Replace sear.</p>	Fig 3-5
Receiver assembly (M3A1)	<p>Inspect barrel retaining spring for looseness or damage.</p>	<p>Evacuate to direct support maintenance.</p> <p><i>Note.</i> Do not attempt to tighten rivets or bend spring.</p> <p>Tighten nut.</p>	
Receiver assembly (M3)	<p>Inspect oiler retaining nut for looseness.</p>	<p>Replace gasket if missing.</p>	Fig 3-5
	<p>Inspect oiler cap for presence of gasket.</p>	<p>Replace.</p>	Fig 3-5
	<p>Inspect magazine catch shield for dents or distortion.</p>	<p>Replace.</p>	Fig 3-5
	<p>Inspect magazine catch for distortion and/or broken tang.</p>	<p>Evacuate to direct support maintenance.</p>	
	<p>Inspect spring for tension.</p>	<p>Replace gasket.</p>	
	<p>Inspect oiler retaining clip for retentive qualities.</p>	<p>Evacuate to direct support maintenance.</p>	
Flash hider assembly	<p>Inspect oiler for gasket leak.</p>	<p>Evacuate to direct support maintenance.</p>	
	<p>Inspect cover for presence of safety catch.</p>	<p>Evacuate to direct support maintenance.</p>	
	<p>Inspect barrel retaining spring for distortion or breakage.</p>	<p>Evacuate to direct support maintenance.</p>	
	<p>Inspect stock extension catch for freedom of movement.</p>	<p>Lubricate and function to induce movement or evacuate to direct support maintenance.</p>	Para 3-6
	<p>Inspect for burrs on wing nut.</p>	<p>Remove burrs.</p>	Para 3-14c
Flash hider assembly	<p>Inspect setscrew for thread damage.</p>	<p>Evacuate to direct support maintenance.</p>	
	<p>Inspect flash hider for distortion.</p>	<p>Evacuate to direct support maintenance.</p>	
	<p>Inspect to insure flash hider is secured tightly to barrel.</p>	<p>Evacuate to direct support maintenance.</p>	

CHAPTER 4

AMMUNITION

4-1. General

Ammunition for the Caliber .45 Submachine Guns, M3 and M3A1 is issued in the form of a complete round. A complete round (cartridge)

consists of all the components (cartridge case, primer, propelling charge, and bullet) necessary to fire the weapon once. Refer to SC 1305/30-IL for identification of various types of ammunition.

CHAPTER 5

DESTRUCTION TO PREVENT ENEMY USE

5-1. General

a. Destruction of the submachine gun when subject to capture or abandonment in the combat zone, will be undertaken only when in the judgment of the commander concerned such action is necessary. If destruction is resorted to, the equipment must not be merely discarded, but must be so badly damaged that it cannot be restored to a usable condition in the combat zone either by repair or cannibalization. The reporting of the destruction of equipment is to be through regular channels.

b. Priorities for destruction of parts are:

- (1) Barrel
- (2) Receiver assembly
- (3) Bolt and guide rod group
- (4) Trigger housing group
- (5) Stock extension

c. The same priority for the destruction of component parts of the submachine gun are to be given to the destruction of similar components in spare parts storage areas.

APPENDIX A

REFERENCES

A-1. Publication Indexes

The following indexes should be consulted frequently for the latest changes or revisions of references given in this appendix and for new publications relating to material covered in this manual.

Index of Administrative Publications	DA Pam 310-1
Index of Army Films, Transparencies, GTA Charts, and Recordings	DA Pam 108-1
Index of Blank Forms	DA Pam 310-2
Index of Doctrinal, Training, and Organizational Publications	DA Pam 310-3
Index of Supply Catalogs and Supply Manuals (excluding types 7, 8, and 9)	DA Pam 310-6
Index of Technical Manuals, Technical Bulletins, Supply Manuals (types 7,8 and 9), Supply Bulletins, and Lubrication Orders	DA Pam 310-4
U.S. Army Equipment Index of Modification Work Orders	DA Pam 310-7

A-2. Forms

DA Form 2028, Recommended Changes to DA Publications.

A-3. Other Publications

The following explanatory publications pertain to this material.

a. *General.*

Accident Reporting and Records	AR 385-40
Administrative Storage of Equipment	TM 740-90-1
Army Equipment Record Procedures	TM 38-750
Authorized Abbreviations and Brevity Codes	AR 320-50
Dictionary of United States Army Terms (Short Title: AD)	AR 320-5
Military Symbols	FM 21-30
Military Training Management	FM 21-5
Physical Security Standards for Protection of Weapons and Ammunition	AR 190-11
Supply Procedures for TOE and TDA Units or Activities	AR 735-35
Submachine Guns, Caliber .45, M3 and M3A1	FM 23-41
Techniques of Military Instruction	FM 21-6

b. *Ammunition.*

Ammunition, General	TM 9-1900
Care, Handling, Preservation and Destruction of Ammunition	TM 9-1300-206
Disposal of Supplies and Equipment:	AR 756-140-1
Ammunition	
Explosives and Demolitions	FM 5-25
Malfunctions Involving Ammunition and Explosives	AR 700-1300-8

c. *Inspection and Maintenance.*

Cleaning of Ordnance Materiel	TM 9-208-1
Materials Used for Cleaning, Preserving, Abrading and Cementing Ordnance Materiel; and Related Materials Including Chemicals	TM 9-247

d. *Issue of Supplies and Equipment.*

Requisitioning, Receipt, and Issue System	AR 725-50
---	-----------

e. *Maintenance of Supplies and Equipment.*

Organization, Policies, and Responsibilities for Maintenance Operations	AR 750-6
---	----------

APPENDIX B

MAINTENANCE ALLOCATION CHART

Section I. INTRODUCTION

B-1. General

The maintenance allocation chart indicates specific maintenance operations performed at the proper maintenance levels. Deviation from maintenance operations allocated in the chart is authorized only upon approval of the commanding officer.

B-2. Maintenance Functions

The maintenance allocation chart designates overall responsibility for the maintenance function on an end item or assembly. Maintenance functions will be limited to and defined as follows:

a. Inspect. To determine serviceability of an item by comparing its physical, mechanical, and electrical characteristics with established standards.

b. Test. To verify serviceability and to detect electrical or mechanical failure by use of test equipment.

c. Service. To clean, to preserve, to charge and to add fuel, lubricants, cooling agents, and air.

d. Adjust. To rectify to the extent necessary to bring into proper operating range.

e. Align. To adjust specified variable elements of an item to bring to optimum performance.

f. Calibrate. To determine the corrections to be made in the readings of instruments or test equipment used in precise measurement. Consists of the comparison of two instruments, one of which is a certified standard of known accuracy, to detect and adjust any discrepancy in the accuracy of the instrument being compared with the certified standard.

g. Install. To set up for use in an operational environment such as an emplacement, site, or vehicle.

h. Replace. To replace unserviceable items with serviceable like items.

i. Repair. Those maintenance operations necessary to restore an item to serviceable condition

through correction of material damage or a specific failure. Repair may be accomplished at each category of maintenance.

j. Overhaul. Normally, the highest degree of maintenance performed by the Army in order to minimize time work in process is consistent with quality and economy of operation. It consists of that maintenance necessary to restore an item to completely serviceable condition as prescribed by maintenance standards in technical publications for each item of equipment. Overhaul normally does not return an item to like new, zero mileage, or zero hour condition.

k. Rebuild. The highest degree of materiel maintenance. It consists of restoring equipment as nearly as possible to new condition in accordance with original manufacturing standards. Rebuild is performed only when required by operational considerations or other paramount factors and then only at the depot maintenance category. Rebuild reduces to zero the hours or miles the equipment, or component there of, has been in use.

l. Symbols. The uppercase letter placed in the appropriate column indicates the lowest level at which that particular maintenance function is to be performed.

B-3. Explanation of Format

Purpose and use of the format are as follows:

a. Column 1, Group Number. Lists group numbers, the purpose of which is to identify components, assemblies, subassemblies and modules with the next higher assembly.

b. Column 2, Functional Group. Lists the noun names of components, assemblies, subassemblies and modules on which maintenance is authorized.

c. Column 3, Maintenance Functions. Lists the various categories of maintenance to be performed on the weapon.

d. *Use of Symbols.* Explanation of the use of symbols in maintenance function column 3 is as follows:

Code	Explanation
C	Operator/Crew
O	Organizational
F	Direct Support
H	General Support
D	Depot

e. *Column 4, Tools and Equipment.* This column is used to specify by code these tools and test equipment required to perform the designated function.

f. *Column 5, Remarks.* Self-explanatory.

Note. Columns not utilized are considered not applicable.

**Section II. MAINTENANCE ALLOCATION CHART FOR CALIBER .45
SUBMACHINE GUNS M3 AND M3A1**

(1) Group No.	(2) Functional Group	(8) Maintenance Function										(4) Tools and equipment	(6) Remarks
		Test	Service	Adjust	Align	Calibrate	Install	Replace	Repair	Overhaul	Rebuild		
1	MAGAZINE		—	C	—	—	—	C	C	—	D		
2	BARREL	C	—	C	—	—	—	O	—	O	D		
3	GUN STOCK EXTENSION	C	—	C	—	—	—	C	F	—	D		
4	BOLT AND GUIDE ROD GROUP	C	—	C	—	—	—	C	—	O	D		
5	TRIGGER HOUSING GROUP (M3A1)	C	—	C	—	—	—	—	—	—	F	D	
6	TRIGGER HOUSING GROUP (M3)	C	—	C	—	—	—	C	—	F	D		
7	TRIGGER AND SEAR GROUP	C	—	C	—	—	—	—	—	O	D		
8	RECEIVER ASSEMBLY (MSA1)	C	—	C	—	—	—	—	—	—	F	D	
9	RECEIVER ASSEMBLY (M3)	C	—	C	—	—	—	C	O	F	D		
10	FLASH HIDER ASSEMBLY	C	—	C	—	—	—	C	O	F	D		

APPENDIX C

ORGANIZATIONAL MAINTENANCE REPAIR PARTS AND SPECIAL TOOLS LIST

Section I. INTRODUCTION

C-1. Scope

This appendix lists basic issue items, repair parts, special tools, required for the performance of organizational maintenance of the Caliber .45, Submachine Guns, M3 and M3A1.

C-2. General

This Basic Issue Items, Repair Parts, and Special Tools List is divided into the following sections:

a. *Basic Issue Items-Section II.* A list of items which accompany the submachine guns and are required by the operator/crew for installation, operation, or maintenance.

b. *Maintenance and Operating Supplies-Section III.* A listing of maintenance and operating supplies required for initial operation.

c. *Prescribed Load Allowance (PLA)-Section IV.* A composite listing of repair parts, special tools, test and support equipment having quantitative allowances for initial stockage at the organizational level.

d. *Repair Parts-section V.* A list of repair parts authorized for the performance of maintenance at the organizational level in figure and item number sequence.

e. *Special Tools, Test and Support Equipment -section VI.* A list of special tools, test and support equipment authorized for the performance of maintenance at the organisational level.

f. *Federal Stock Number and Reference Number Index-Section VII.* A list of Federal stock numbers in ascending numerical sequence, followed by a list of reference numbers appearing in all the listings, in ascending alphanumeric sequence, cross-referenced to the illustration figure number and item number.

C-3. Explanation of Columns

The following provides an explanation of columns in the tabular lists in Sections II through VI,

a. *Source, Maintenance and Recoverability Codes (SMR).*

(1) *Source Code.* Indicates the selection status and source for the listed item, Source codes used are:

Code	Definition
P	Repair parts which are stocked in or supplied from the GSA/DSA, or Army supply system, and authorized for use at indicated maintenance categories.
P2	Repair parts which are procured and stocked for insurance purposes because the combat or military essentiality of the end item dictates that a minimum quantity be available in the supply system.
M	Repair parts which are not procured or stocked but are to be manufactured in indicated maintenance levels.
A	Assemblies which are not procured or stocked as such but are made up of two or more units. Such component units carry individual FSN's and descriptions, are procured and stocked separately and can be assembled to form the required assembly at indicated maintenance categories.
X	Parts and assemblies which are not procured or stocked and the mortality of which is normally below that of the applicable end item or component. The failure of such part or assembly should result in retirement of the end item from the supply system.
X1	Repair parts which are not procured or stocked. The requirement of such items will be filled by use of the next higher assembly or component.
x2	Repair parts which are not stocked. The indicated maintenance category requiring such repair parts will attempt to obtain through cannibalization; if not obtainable through cannibalization, such repair parts will be requisitioned with supporting justification through normal supply channels.

G Major assemblies that are procured with PEMA funds for initial issue only to be used as exchange assemblies at DSU and GSU level. These assemblies will not be stocked above DSU and GSU level or returned to Depot supply level.

(2) *Maintenance Code*. Indicates the lowest category of maintenance authorized to install the listed item. The maintenance level codes are:

Code	Maintenance Category
C	Operator/crew
O	Organizational
F	Direct Support
H	General Support
D	Depot

(3) *Recoverability Code*. Indicates whether unserviceable items should be returned for recovery or salvage. Items not coded are expendable. Recoverability codes are:

Code	Recoverability Aspect
R	Applied to repair park (assemblies and components), special tools and test equipment which are considered economically repairable at Direct end General support maintenance levels. When the item is no longer economically repairable, it is normally disposed of at GS level. When supply considerations dictate, some of these repair parts may be listed for automatic return to supply for Depot level repair as set forth in AR 710-50. When so listed, they will be replaced by supply on an exchange basis.
8	Repair parts and assemblies which are economically repairable at DSU and GSU activities and normally are furnished by supply on an exchange basis. When items are determined by a GSU to be uneconomically repairable, they will be evacuated at a depot for evaluation and analysis before final disposition.
T	High dollar value recoverable repair parts which are subject to special handling and are issued on an exchange basis. Such repair parts are normally repaired or overhauled at Depot maintenance activities.
U	Repair parts specifically selected for salvage by reclamation units because of precious metal content, critical materials, high dollar value reusable casings, or castings.

No code

Indicated Part will be considered expendable,

b. *Federal Stock Number*. Indicates the Federal stock number assigned to the item and will be used for requisitioning purposes.

c. *Description*. Indicates the Federal item name and any additional description of the item required. The abbreviation "w/e" when used as a part of the nomenclature, indicates the Federal stock number includes all armament equipment,

accessories, and repair parts issued with the item. A part number or other reference number is followed by the applicable five-digit Federal supply code for manufacturers in parentheses.

d. *Unit of Measure (U/M)*. A 2 character alphabetic abbreviation indicating the amount or quantity of the item upon which the allowances are based, e.g., ft, ea, pr, etc.

e. *Quantity Incorporated in Unit*. Indicates the quantity of the item used in the functional group or assembly. A "V" appearing in this column in lieu of a quantity indicates that a definite quantity cannot be indicated (e.g., shims, spacers, etc.).

f. *Quantity Furnished with Equipment*. Indicates the quantity of an item furnished with the equipment (BIIL only).

g. *Component Application*. Identifies the component application of each maintenance or operating supply item (M&O supplies only).

h. *Quantity Required for Initial Operation*. Indicates the quantity of each maintenance or operating supply item required for initial operation of the equipment (M&O supplies only).

i. *Quantity Required for 8 Hours Operation*. Indicates the estimated quantities required for an average 8 hours of operation (M&O supplies only).

j. *Notes*. Indicates informative notes keyed to data appearing in a preceding column (M&O supplies only).

k. *15-Day Organizational Maintenance Allowances*.

(1) The allowance columns are divided into four subcolumns. Indicated in each subcolumn opposite the first appearance of each item is the total quantity of items authorized for the number of equipments supported. Subsequent appearances of the same item will have the letters "REF" in the allowance columns. Items authorized for use as required but not for initial stockage are identified with an asterisk in the allowance column.

(2) The quantitative allowances for organizational level of maintenance represents one initial prescribed load for a 15-day period for the number of equipments supported. Units and organizations authorized additional prescribed loads will multiply the number of prescribed loads authorized by the quantity of repair parts reflected in the appropriate density column to obtain the total quantity of repair parts authorized.

(3) Organizational units providing maintenance for more than 100 of these equipment shall determine the total quantity of parts re-

quired by converting the equipment quantity to a decimal factor by placing a decimal point before the next to last digit of the number to indicate hundredths, and multiplying the decimal factor by the parts quantity authorized in the 51-100 allowance column. Example, authorized allowance for 51-100 equipments is 12; for 140 equipments multiply 12 by 1.40 or 16.80 rounded off to 17 parts required.

(4) Subsequent changes to allowances will be limited as follows: No change in the range of items is authorized. If additional items are considered necessary, recommendation should be forwarded to Commanding General, Headquarters, U.S. Army Weapons Command, ATTN: AMSWE-SMM-SA, Rock Island, Illinois 61201, for exception or revision to the allowance list. Revisions to the range of items authorized will be made by Headquarters, U.S. Army Weapons Command based upon engineering experience, demand data, or TAERS information.

l. Illustration.

(1) *Figure Number.* Indicates the figure number of the illustration in which the item is shown.

(2) *Item Number.* Indicates the call-out number used to reference the item in the illustration.

C-4. Special Information

Identification of the usable on codes of this publication are:

Code	Used on
A	M3
B	M3A1
No Code	M3 and M3A1

C-5. How to Locate Repair Parts

a. When Federal stock number or reference number is unknown:

(1) *First.* Using the table of contents determine the functional group or assembly, within

which the repair part belongs. This is necessary since illustrations are prepared for functional groups and assemblies, and listings are divided into the same groups.

(2) *Second.* Find the illustration covering the functional group or assembly to which the repair part belongs.

(3) *Third.* Identify the repair part on the illustration and note the illustration figure and item number of the repair part.

(4) *Fourth.* Using the Repair Parts Listing, find the functional group or assembly to which the repair part belongs and locate the illustration figure and item number noted on the illustration.

b. When Federal stock number or reference number is known:

(1) *First.* Using the Index of Federal Stock Numbers and Reference Numbers find the pertinent Federal stock number or reference number. This index is in ascending FSN sequence followed by a list of reference numbers in alphanumeric sequence, cross-referenced to the illustration figure number and item number.

(2) *Second.* Using the Repair Part Listing, find the functional group or assembly of the repair part and the illustration figure number and item number referenced in the Index of Federal Stock Numbers and Reference Numbers.

C-6. Abbreviations

Abbreviation	Explanation
DIA-----	Diameter
ID-----	Inside Diameter
OD-----	Outside Diameter
SH-SLEEVE-----	Sheet Sleeve
SQ-----	Square
SYNTH-RBR-----	Synthetic Rubber
THK-----	Thick

C-7. Federal Supply Codes for Manufacturers

Code	Manufacturer
19204 -----	Rock Island Arsenal
19205-----	Springfield Armory

Section II. BASIC ISSUE ITEMS LIST

(1) Source Maint. and Recov. Code			(2) Federal stock No.	(3) Description Usable On Code	(4) Unit of meas	(5) Qty. Inc in Unit	(6) Qty. Furn. with Equip	(7) Illustration	
(a) source	(b) maint.	(c) recov.						(a) Fig. No.	(b)
P	C	---	1005-565-3427	SUBMACHINE GUN, CALIBER .45, M3 AND M3A1 REPAIR PARTS	EA	1	15	C1	1
			1005-550-4036	MAGAZINE, CARTRIDGE : 5653427 (19204)					
				TOOLS AND EQUIPMENT					
			1005-550-4036	BRUSH, CLEANING, SMALL ARMS: M5, BORE 5504036 (19204)	EA	--	1		
			1005-610-8828	BRUSH, CLEANING, SMALL ARMS: M6 CHAMBER 6108828 (19204)	EA	--	1	C8	
			1005-726-5879	CAP, MAGAZINE : 7265879 (19204)	EA	--	15	C8	
			1005-565-3481	FILLER, MAGAZINE : M1 5653481 (19204)	EA	--	1	C8	
			1005-726-5628	FLASH HIDER ASSEMBLY: M9 7265628 (19204)	EA	--	1	C8	5
			1005-556-4364	OILER, CARBINE : 5564364 (19204)	EA	--	1	C8	9
			1005-555-7152	SLING, SMALL ARMS: 5557152 (19204)	EA	--	1	C8	8

Section III. **MAINTENANCE AND OPERATING SUPPLIES**

(1) Component Application	(2) Federal Stock Number	(3) Description	(4) Qty. Required for initial operation	(5) Qty. required for 8 hours operation	(6) Notes
SUBMACHINE GUNS, CALIBER .45, M3 AND M3A1	1005-288-3565	SWAB, SMALL ARMS CLEANING: COTTON 2 1/2 SQ. (1000 IN PKG) 5019316 (19204)	*		

Section IV. PRESCRIBED LOAD ALLOWANCE

(1) Federal stock No.	(2) Description Usable on code	(3) Qty. inc. in unit pack	(4) 15-day organizational maint. allowance			
			(a) 1-5	(b) 6-20	(c) 21-50	(d) 51-100
	REPAIR PARTS					
1005-200-5864	SPRING, HELICAL COMPRESSION			2	2	3
1005-519-6456	GASKET		--	2	3	5
1005-534-9931	CLIP, RETAINING		--	2	2	3
1005-565-3427	MAGAZINE, CARTRIDGE		2	2	4	7
1005-630-1453	CATCH, MAGAZINE		--	2	2	3
1005-630-1456	GUARD, TRIGGER			2	2	3
1005-630-1464	EXTRACTOR, CARTRIDGE		--	2	2	2
1005-716-0997	SHIELD			2	2	3
1005-716-0999	SPRING, HELICAL, COMPRESSION		--	2	2	2
1005-716-1911	GASKET		--	2	2	3
1005-716-2774	SEAR		--		2	2
	TOOLS AND EQUIPMENT					
1005-288-3565	SWAB, SMALL ARMS CLEANING		--	--	2	2
1005-550-4036	BRUSH, CLEANING, SMALL ARMS		--	--	2	2
1005-555-7152	SLING, SMALL ARSM		--	2	2	3
1005-556-4364	OILER, CARBINE			--	2	2
1005-610-8828	BRUSH, CLEANING, SMALL ARMS		--	2	2	3
1005-726-5628	FLASH HIDER ASSEMBLY		--	--	2	2
1005-726-5879	CAP, MAGAZINE		2	2	4	7
4933-726-6175	TOOL, REMOVER, EXTRACTOR PIN		--	--	2	2

Section V. REPAIR PARTS LIST

(1) Source maint and recov code			(2) Federal stock No.	(3) Description <i>Reference Number & Mfr Code Usable on Code</i>	(4) Unit of meas	(5) Qty inc in mit	(6) 15- I organizational ntenance alw				(7) Illustra m	
(a) source	(b) maint	(c) recov					(a) 1-5	(b) 1-20	(c) 1-50	(d) 51-100	(a) Figure No.	(b) Item No.
				REPAIR PARTS FOR: MAJOR GROUPS, ASSEMBLIES AND COMPONENT PARTS								
P	C		1005-565-3427	MAGAZINE, CARTRIDGE: 5653427 (19204)	EA	1	2	2	4	7	C1	1
P	O		1005-630-1456	GUARD, TRIGGER: 6301456 (19204)	EA	1	*	2	2	3	C1	2
P	O		1005-630-1453	CATCH, MAGAZINE: 6301453 (19204)	EA	1	*	2	2	3	C1	3
P	O		1005-200-5864	SPRING, HELICAL, COMPRESSION: 7160998 (19204)	EA	1	*	2	2	3	C1	4
P	O		1005-716-0997	SHIELD: 8160997 (19204)	EA	1	*	2	2	3	C1	5
P	O		1005-716-2774	SEAR: 7162774 (19204)	EA	1	*	*	2	2	C1	6
P	O		1005-716-1911	GASKET: NONMETALIC, SYNTH- B RBR, 0.490 OD, 0.290 ID, 0.060 THK 7161911 (19204)	EA	1	*	2	2	3	C1	7
				BOLT AND GUIDE ROD GROUP								
P	O		1005-534-9931	CLIP, RETAINING: 5349931 (19205)	EA	1	*	2	2	3	C2	1
P	O		1005-630-1464	EXTRACTOR, CARTRIDGE: 6301464 (19204)	EA	1	*	2	2	2	C2	2
P	O		1005-716-0999	SPRING, HELICAL, COMPRESSION: 7160999 (19204)	EA	2	*	2	2	2	C2	3
				OILER, CARBINE								
P	O		1005-519-6456	GASKET: SYNTH-RBR, 0.200 ID, 0.383 OD 0.060 THK, OILER TUBE A 5196456 (19204)	EA	1	*	2	3	5	C3	10

Section VI. SPECIAL TOOLS, TEST AND SUPPORT EQUIPMENT

(1) Source maint an recov cod			(2) Federal stock No.	(3) Description <i>Reference Number & Mfr Code</i> <i>Usable on Cod</i>	(4) Unit of meas	(5) Qty inc in unit	(6) 15-day organizational maintenance alw				(7) Illustration	
(a) source	(b) maint	(c) recov					(a) 1-5	(b) -20	(c) 1-50	(d) 1-100	(a) Figure No.	(b) Item No.
				TOOLS AND EQUIPMENT AUTHORIZED FOR UNIT REPLACEMENT								
			1005-288-3565	SWAB, SMALL ARMS CLEANING: COTTON 2-1/2 SQ (1,000 IN PKG) 5019816 (19204)	PG	--	*	*	2	2	C3	8
			1005-550-4036	BRUSH, CLEANING, SMALL ARMS: M5, BORE 5504036 (19204)	EA	--	*	*	2	2		
			1005-555-7152	SLING, SMALL ARMS: 5557152 (19204)	EA	--	*	2	2	3	C3	8
			1005-556-4364	OILER, CARBINE: 5564364 (19204)	EA	--	*	*	2	2	C3	9
			1005-565-3431	FILLER, MAGAZINE: M1 5653431 (19204)	EA	--	*	*	*	*	C3	4
			1005-610-8828	BRUSH, CLEANING, SMALL ARMS: M6, CHAMBER 6108828 (19204)	EA	--	*	2	2	3	C3	11
			1005-726-5628	FLASH HIDER ASSEMBLY: 7265628 (19204)	EA	--	*	*	2	2	C3	6
			1005-726-5879	CAP, MAGAZINE: 7265879 (19204)	EA	--	2	2	4	7	C3	
				TOOLS AND EQUIPMENT FOR ARMORERS USE								
				THE 15-DAY LEVEL, DOES NOT APPLY								
			1005-555-9738	BAG: CANVAS, SPARE PARTS 5559738 (19204)	EA	--	*	*	*	*	C3	1
			1005-722-8907	ENVELOPE: FABRIC, 2 BUTTON, 4-7/8 X 3 7228907 (19204)	EA	--	*	*	*	*	C3	2
			4933-726-6175	TOOL, REMOVER, EXTRACTOR PIN: 7266175 (19204)	EA	--	*	*	2	2	C3	7
				MAINTENANCE SUPPLIES								
			8020-244-0153	BRUSH, ARTISTS: METAL FERRULE, FLAT, CHISEL EDGES, 7/16W, 1-1/8 LG EXPOSED	EA	--	*	*	*	*		
			7920-205-2401	BRUSH, CLEANING, TOOL AND PARTS: RD, 100 PERCENT TAMPICO FIBER, 1-1/16 AT FERRULE BRUSH DIA, 2-7/8 CLEAR OF BLOCK BRUSH LG	EA	--	*	*	*	*		
			6850-965-2332	CARBON REMOVING COMPOUND: (P-C-111) (5 GAL PAIL) CLEANING COMPOUND, RIFLE BORE: (CF	PL	--	*	*	*	*		
			6850-224-6656	2 OZ BOTTLE								
			6850-224-6657	6 OZ CAN	OZ	--	*	*	*	*		
			6850-224-6658	1 QT CAN,	OZ	--	*	*	*	*		
			6850-224-6663	1 GAL CAN	QT	--	*	*	*	*		
			5350-221-0872	CLOTH, ABRASIVE, CROCUS: FERRIC OXIDE AND QUARTZ, JEAN-CLOTH-BACKING, CLOSED COATING, 9W 11 LG 50 SH-SLEEVE (CA)	GL	--	*	*	*	*		
					SH	--	*	*	*	*		

(1) Source maint and reserv code			(2) Federal stock No.	(3) Description <i>Reference Number & Mfr Code</i> <i>Usable on Code</i>	(4) Unit of meas	(5) Qty inc in unit	(6) 3-day main nan ational slw				(7) Instr on	
(a)	(b)	(c)					(a)	(b)	(c)	(d)	(a)	(b)
source	maint	reserv					1-5	1-20	1-50	1-100	Figure No.	Item No.
			6850-281-1985	DRY CLEANING SOLVENT: (SD) (1 GAL CAN)	GL		*	*	*	*		
			9150-273-2389	LUBRICATING OIL, GENERAL PURPOSE : (PL SPECIAL) 4 OZ CAN	OZ		*	*	*	*		
			9150-231-6689	1 QT CAN	QT	--	*	*	*	*		
			9150-292-9689	LUBRICATING OIL, WEAPONS : (LAW) FOR ZERO OPERATIONS FOR BELOW (1 QT CAN)	QT	--		*	*	*		
			7920-205-1711	RAG, WIPING : COTTON (50 LB BALE)	LB	--	*	*	*	*		

Section VII. INDEX-FEDEUAL STOCK NUMBER AND REFERENCE NUMBER CROSS-REFERENCE TO FIGURE AND ITEM NUMBER

Stock Number	Figure No.	Item No.	Stock Number	Figure No.	Item No.
1005-200-5864	C 1	4	1005-630-1456	C 1	2
1005-288-3565	C 3	8	1005-630-1464	C 2	2
1005-519-6456	C 3	10	1005-716-0997	C 1	5
1005-534-9931	C 2	1	1005-716-0999	C 2	3
1005-555-7152	C 3	3	1005-716-1911	C 1	7
1005-555-9738	C 3	1	1005-716-2774	C 1	6
1005-556-4364	C 3	9	1005-722-8907	C3	2
1005-565-3427	C 1	1	1005-726-5628	C3	5
1005-610-8828	C 3	11	1005-726-5879	C3	6
1005-630-1453	C 1	3	4933-726-6175	C3	7

Reference No.	Mfg. Code	Fig. No.	Item No.	Reference No.	Mfg. Code	Fig. No.	Item No.
5019316	19204	C3	8	6301464	19204	C 2	2
5196456	19204	C8	10	7160997	19204	C 1	5
5349931	19205	C2	1	7160998	19204	C1	4
5557152	19204	C3	3	7160999	19204	C 2	3
5559738	19204	C3	1	7161911	19204	C 1	7
5564364	19204	C3	9	7162774	19204	C 1	6
5653427	19204	C1	1	7228907	19204	C3	2
5653431	19204	C3	4	7265628	19204	C3	5
6108828	19204		11	7265879	19204	C3	6
6301453	19204	C3	3	7266175	19204	C3	7
6301456	19204	C1	2				

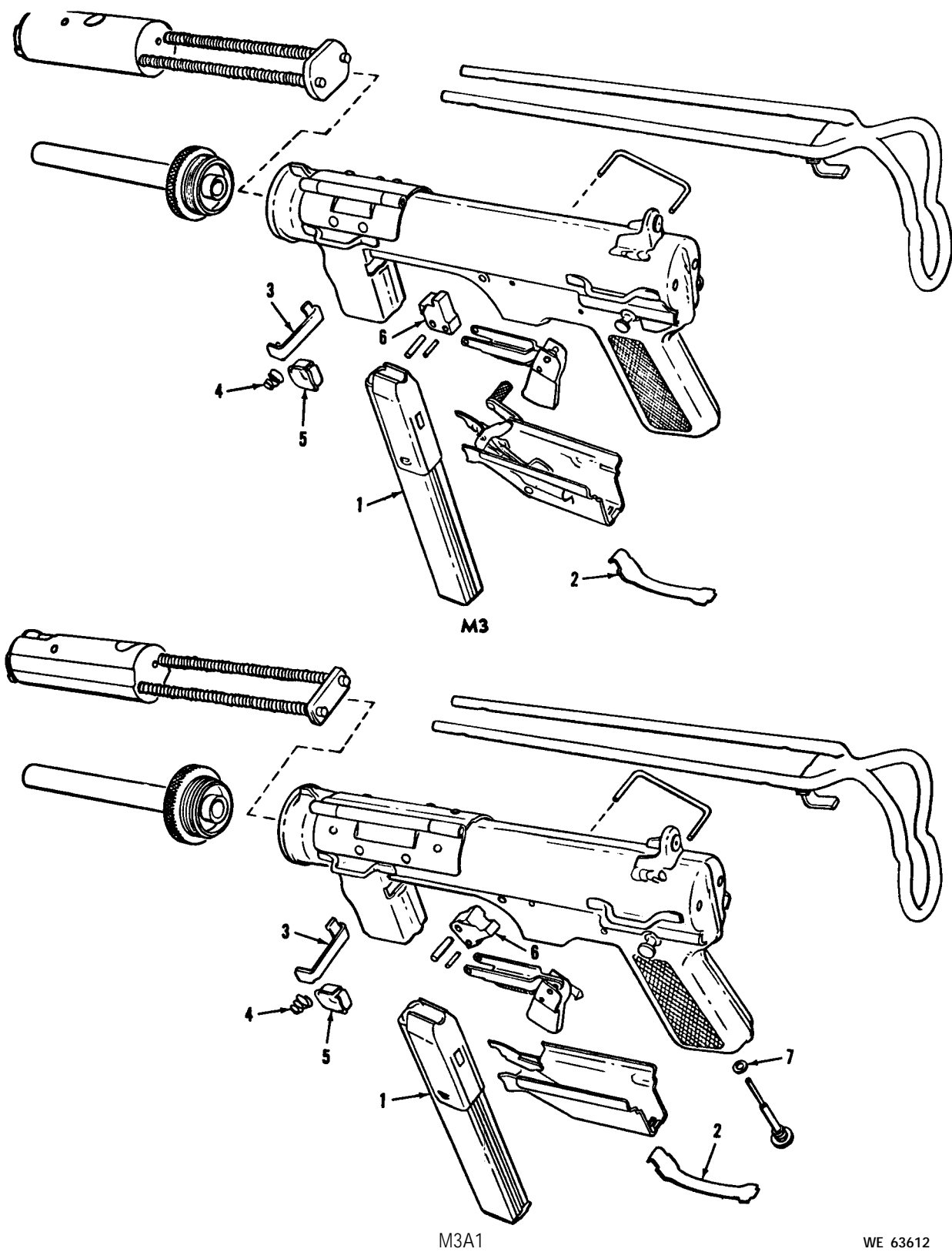

WE 63612

Figure C-1. Major groups assemblies and components-Caliber .45 Submachine Guns M3 and M3A1.

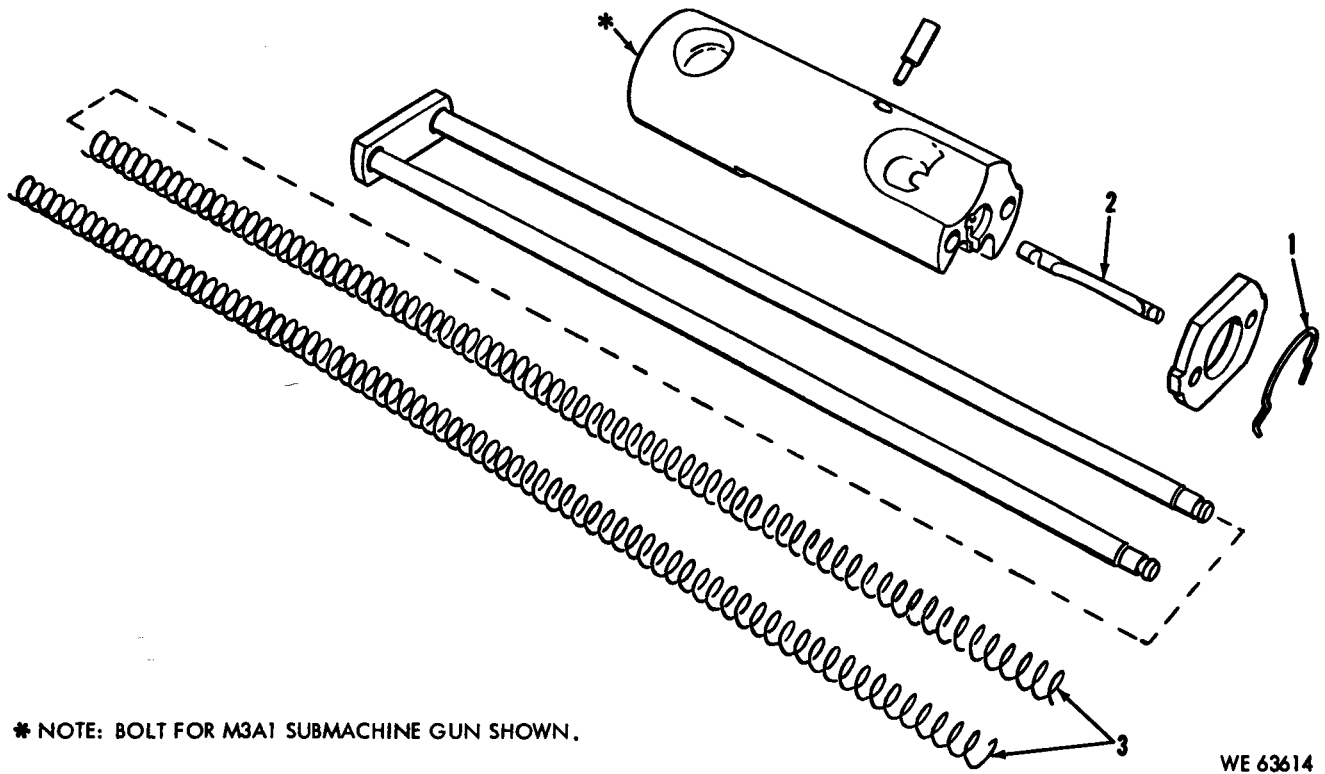

Figure C-2. Bolt and guide rod group.

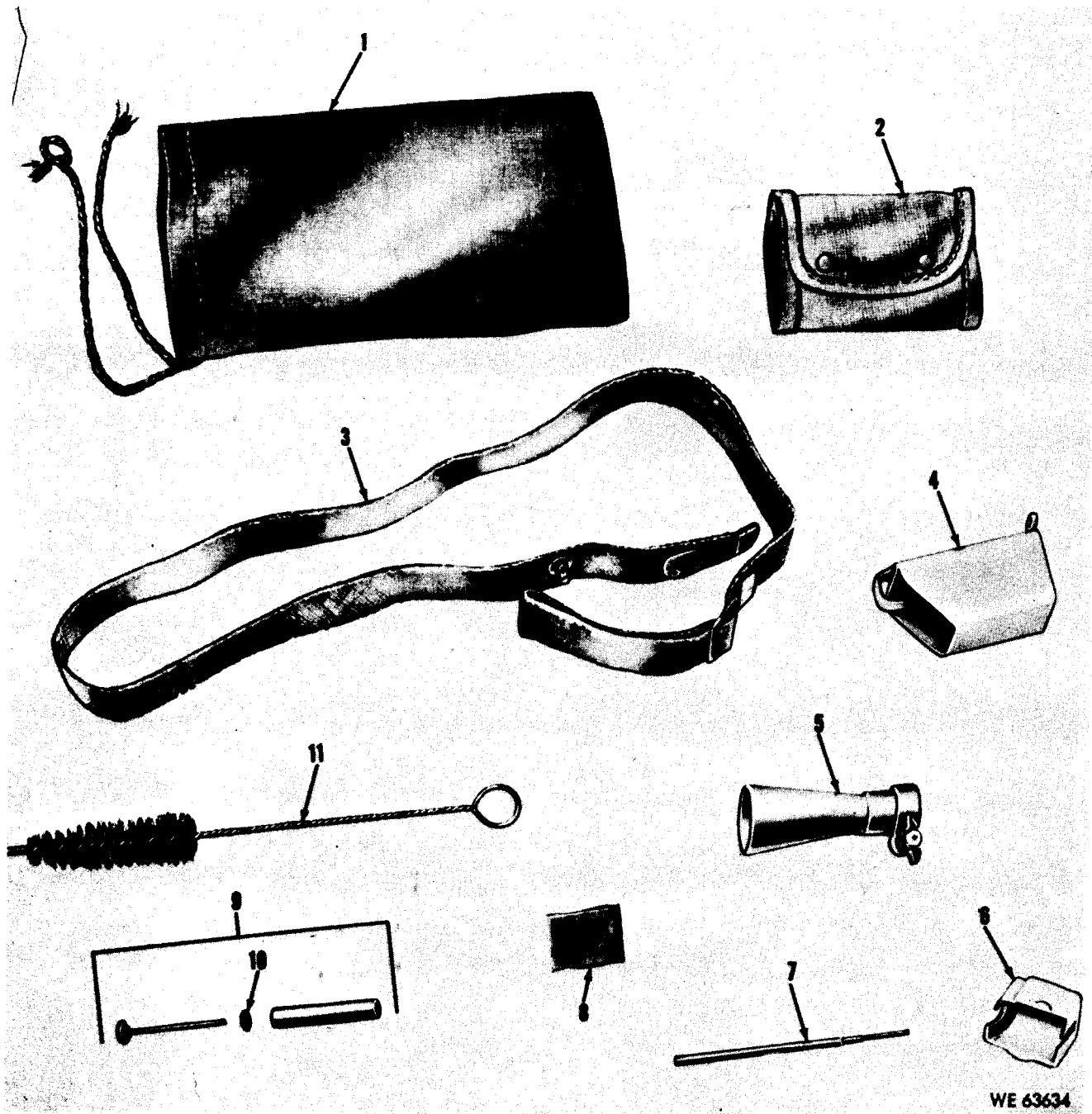

Figure C-3. Tools and equipment.

By order of the Secretary of the Army:

Official:

KENNETH G. WICKHAM,
Major General, United States Army
The Adjutant General

W. C. WESTMORELAND,
General, United States Army,
Chief of Staff.

DISTRIBUTION:

To be distributed in accordance with DA Form 12-40 (qty req block no. 108) organizational maintenance requirements for Submachine Guns, Caliber .45: M3 and M3A1.

This fine document...

Was brought to you by me:



[Liberated Manuals -- free army and government manuals](#)

Why do I do it? I am tired of sleazy CD-ROM sellers, who take publicly available information, slap “watermarks” and other junk on it, and sell it. Those masters of search engine manipulation make sure that their sites that sell free information, come up first in search engines. They did not create it... They did not even scan it... Why should they get your money? Why are not letting you give those free manuals to your friends?

I am setting this document FREE. This document was made by the US Government and is NOT protected by Copyright. Feel free to share, republish, sell and so on.

I am not asking you for donations, fees or handouts. If you can, please provide a link to liberatedmanuals.com, so that free manuals come up first in search engines:

<A HREF=<http://www.liberatedmanuals.com/>>Free Military and Government Manuals

– Sincerely
Igor Chudov
<http://igor.chudov.com/>