



Class TA 676

Book S 58

MODERN
STONE-CUTTING AND MASONRY.

*WITH SPECIAL REFERENCE TO THE MAKING
OF WORKING DRAWINGS.*

BY
JOHN S. SIEBERT, C.E.,
AND
FREDERIC CHILD BIGGIN, B.S.,
ARCHITECT
Instructor in Architecture, Lehigh University.

FIRST EDITION.

FIRST THOUSAND.

NEW YORK:
JOHN WILEY & SONS.
LONDON: CHAPMAN & HALL, LIMITED.

1902.

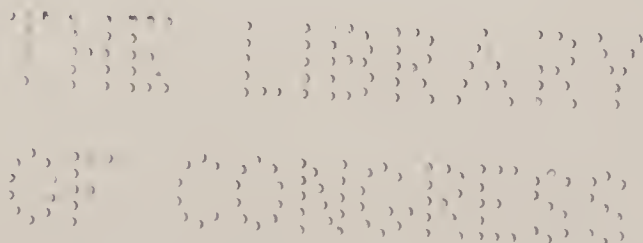

TA 676
558

~~TL 558~~

Copyright, 1896,
BY
JOHN S. SIEBERT
AND
FREDERIC C. BIGGIN.

53916
out

PRESS OF
BRAUNWORTH & CO.
BOOKBINDERS AND PRINTERS
BROOKLYN, N. Y.

4-180 24/4 per

WILSON
LIBRARY

PREFACE.

IT has long been recognized that the works on stone-cutting used in this country are entirely out of date and not abreast of the present demands.

The reasons are apparent. Those works were modelled strictly on lines set by the French school, which dealt chiefly with the heavy masonry of fortifications, and the intricate stone constructions used for the immense churches and cathedrals, built when the Church throughout Europe was in the zenith of its power. Times have changed. The heaviest masonry is no protection against modern projectiles, and steel frames veneered with stone and brick form the walls of our largest buildings. This is not the place to discuss the merits of the different styles of construction, the grace of the stone arch and the steel cantilever, or to place the beauty of a stone carving in opposition to the hard lines of iron ornament; suffice it to say that first cost is a very important factor in this country, and that, stability and usefulness being equal, the cheaper structure is generally adopted.

Intricate stonework is therefore excluded everywhere, save on very costly structures, and a treatise dealing with such work would be interesting and valuable only in so far as it presented problems to be worked by the student in search of exercise for his mental powers.

It has been the aim of the authors, in this little volume, to collect and make available for the student's use only such material as finds a direct application in engineering and architectural practice in this country. Chapter I describes the mason's and stone-cutter's tools, the shape and finish produced by these, the classification of masonry according to shape and finish, as defined by the best existing authorities, and closes with a few general remarks on bond, dressing, etc.

Chapter II deals with stone-cutting and masonry proper, and after a few preliminary definitions and descriptions takes up the study of the different examples chosen. The explanations are detailed where thought necessary, but some of the drawings are intended only as models according to which the student should make similar ones.

The skew or oblique arch is not treated here, because it is rarely used; the right arch with skew face, Plate VIII, or some other simple expedient being substituted. If it becomes necessary to build a true skew arch, the student should refer to "*Traité Pratique de la Coupe des Pierres*," by Émile Lejeune, Paris; the German works of Dr. Ringleb; and the American publications of Prof. Warren bearing on the subject.

The drawings should in all cases be made at least to a scale of one fourth inch per foot, with details three times this size; better still if both can be made double the scales mentioned, although it should be borne in mind that those first given are the ones commonly used in practice. Let the work be executed accurately, neatly, and with strong lines, remembering that nearly all office drawings are nowadays made on tracing-linen, for blue-printing, and that fancy titles are not in demand. The draughtsman who can make the plain Roman letters well has a broad foundation for all styles of lettering.

For exercises other than those given in the book the teacher should select some good existing masonry structures, have the class take full measurements of them, and then make complete drawings in accordance with the samples given in these pages. Models should always be available for the student, and the authors have in preparation a series of models illustrating various stone-cutting problems. They may be obtained direct from the undersigned.

The authors desire to acknowledge their indebtedness to Mr. Bernard R. Green, superintendent and engineer of the building for the Library of Congress; Messrs. Webster and Shaw, engineers of the Lehigh Valley Railroad; and Messrs. E. S. Wheeler and J. L. Callard, United States engineers on the Sault Ste. Marie Canal, for the valuable material furnished for use in this book.

JOHN S. SIEBERT.

SOUTH BETHLEHEM, PA.,
Jan. 1, 1896.

TABLE OF CONTENTS.

CHAPTER I.

DEFINITIONS AND CLASSIFICATIONS.

	PAGE
Art. 1. Names and Definitions of Stone-mason's Tools	1
Art. 2. Stones Classified according to Finish	6
Art. 3. Definitions of Parts of the Structure	10
Art. 4. Classification of Masonry	12

CHAPTER II.

STONE-CUTTING AND MASONRY.

Art. 1. Definitions	18
Art. 2. Gothic Buttress	21
Art. 3. Arches	23
Art. 4. Intersecting Arches	32
Art. 5. Arch-culverts	35
Art. 6. Railroad-bridge Masonry,	41
Art. 7. Canal-lock Masonry	44
Art. 8. Architectural Stonework	46

MODERN STONE-CUTTING AND MASONRY.

CHAPTER I.

DEFINITIONS AND CLASSIFICATIONS.

ART. I.—NAMES AND DESCRIPTIONS OF STONE-MASON'S TOOLS.

1. The following definitions of stone-mason's tools and masonry are taken from the report of the Committee of the American Society of Civil Engineers, prepared to secure uniformity of nomenclature on this subject. (See Trans. Am. Soc. C. E., vol. v. 1. pp. 297-304.)

2. The tools used at the quarry for roughly shaping the stones for transportation and also for shaping for the lower grades of masonry are (see Fig. 1): the *Double-face Hammer*, a tool weighing from 20 to 30 pounds; the *Face-hammer*, having one blunt and one cutting edge and weighing less than the double-face hammer; the *Cavil*, having one blunt and one pointed or pyramidal end and weighing from 15 to 20 pounds; the *Pick* somewhat resembles the pick used in digging, is mostly used on limestone and sandstone, and is from 15 to 24 inches long, the thickness at the eye being about 2 inches.

The tools shown in Figs. 2-6 are used for dressing proper.

The *Axe* or *Pean-hammer* (Fig. 2) has two opposite cut-

ting edges. It is used for making drafts around the arris or edge of stones, and in reducing faces and sometimes joints to a level. Its length is about 10 inches and the cutting

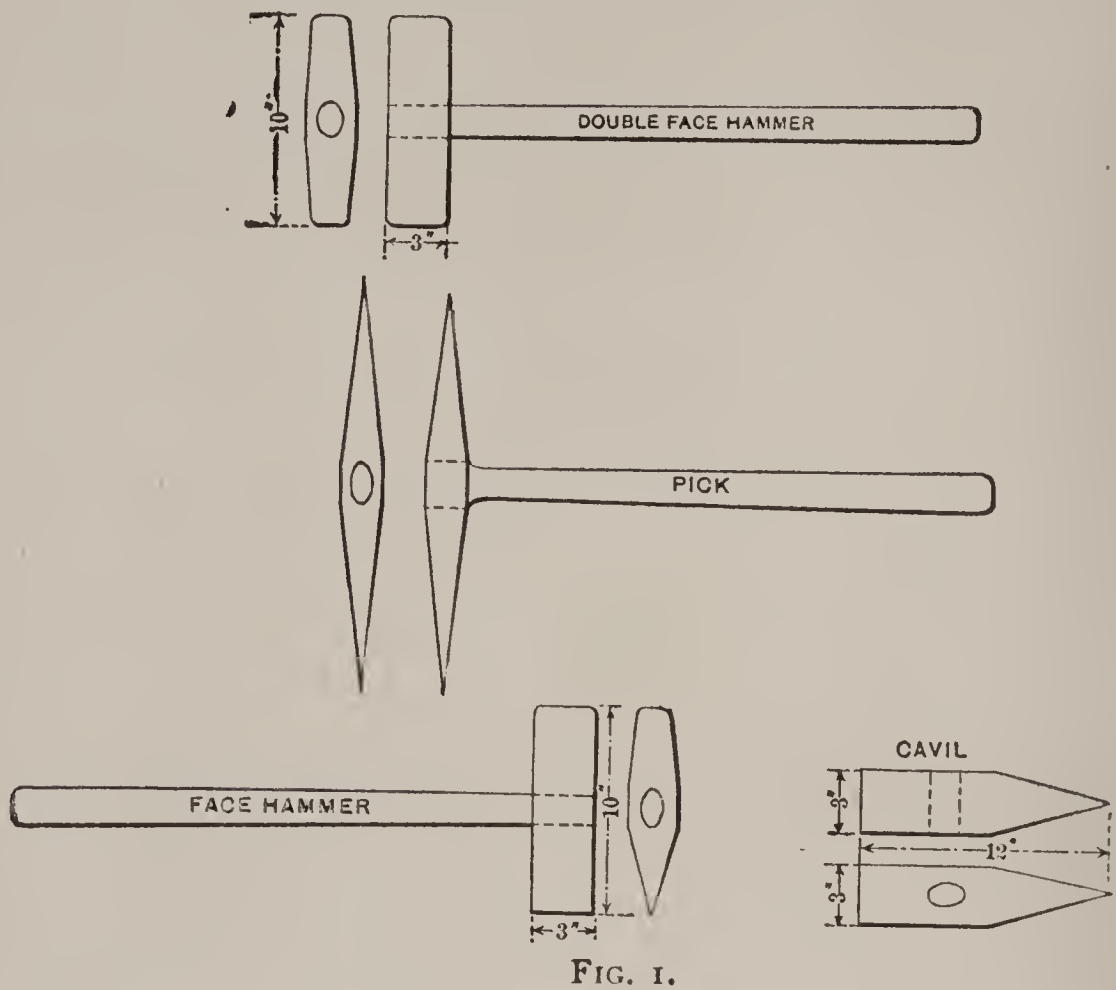

FIG. 1.

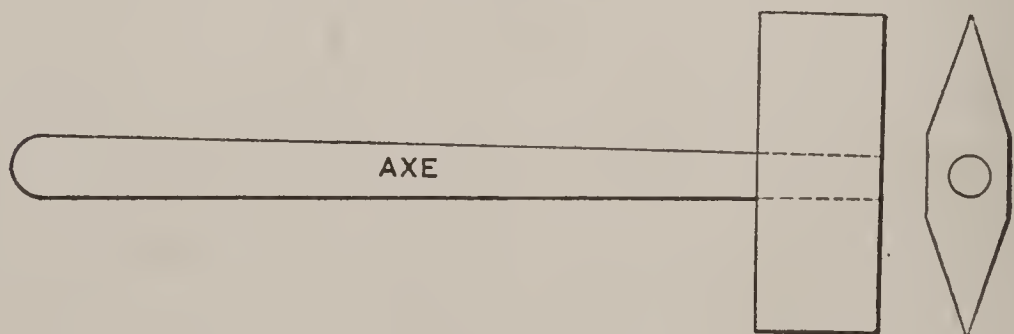

FIG. 2.

edge about 4 inches. It is used after the point and before the patent hammer.

The *Tooth-axe* (Fig. 3) is like the axe, except that its cutting edges are divided into teeth, the number of which vary with the kind of work required. This tool is not used in granite and gneiss cutting.

The *Bush-hammer* (Fig. 4) is a square prism of steel whose ends are cut into a number of pyramidal points. The

length of the hammer is from 4 to 8 inches, and the cutting face from 2 to 4 inches square. The points vary in number

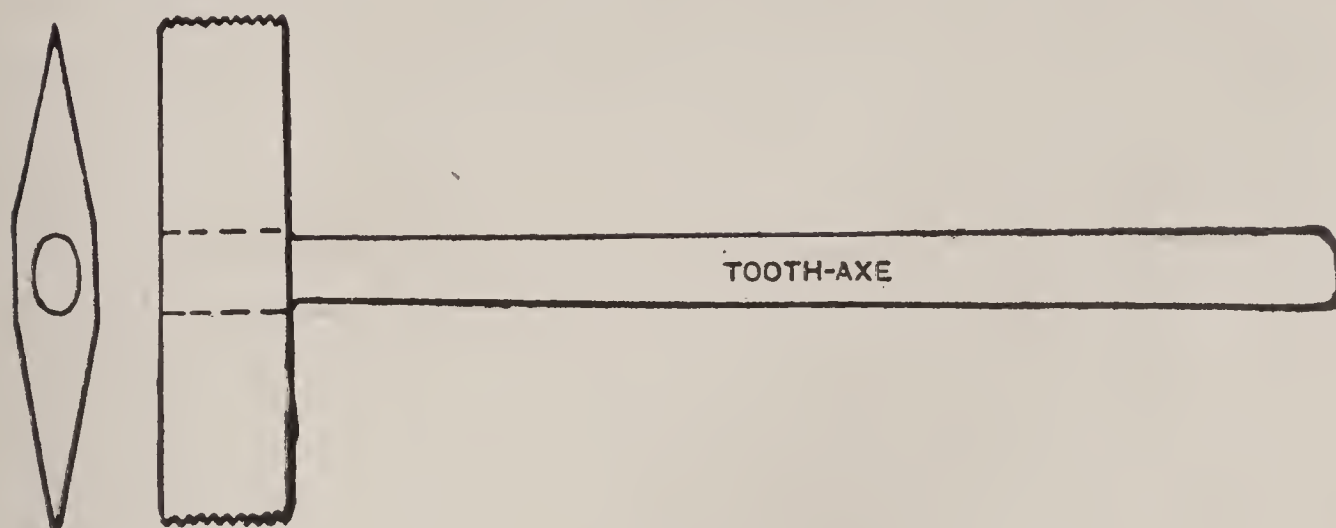

FIG. 3.

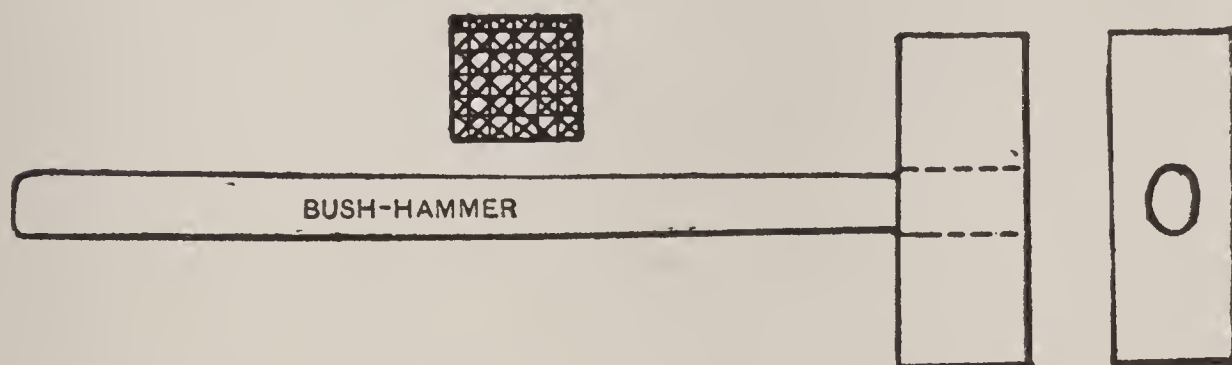

FIG. 4.

and in size with the work to be done. One end is sometimes made with a cutting edge like that of an axe.

The *Crandall* (Fig. 5) is a malleable-iron bar about 2 feet

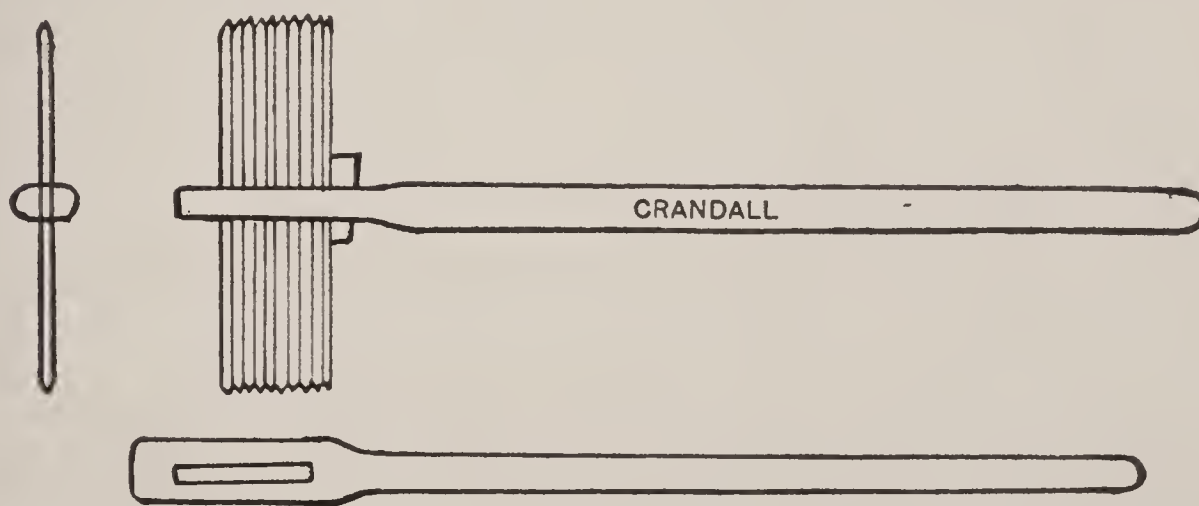

FIG. 5.

long, slightly flattened at one end. In this end is a slot, 3 inches long and $\frac{2}{3}$ inch wide. Through this slot are passed

ten double-headed points of $\frac{1}{4}$ -inch squared steel, 9 inches long, which are held in place by a key.

The *Patent Hammer* (Fig. 6) is a double-headed tool so formed as to hold at each end a set of wide thin chisels.

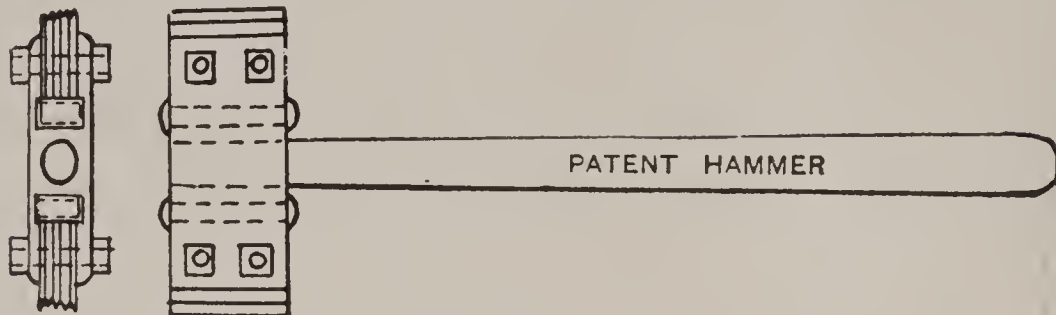

FIG. 6.

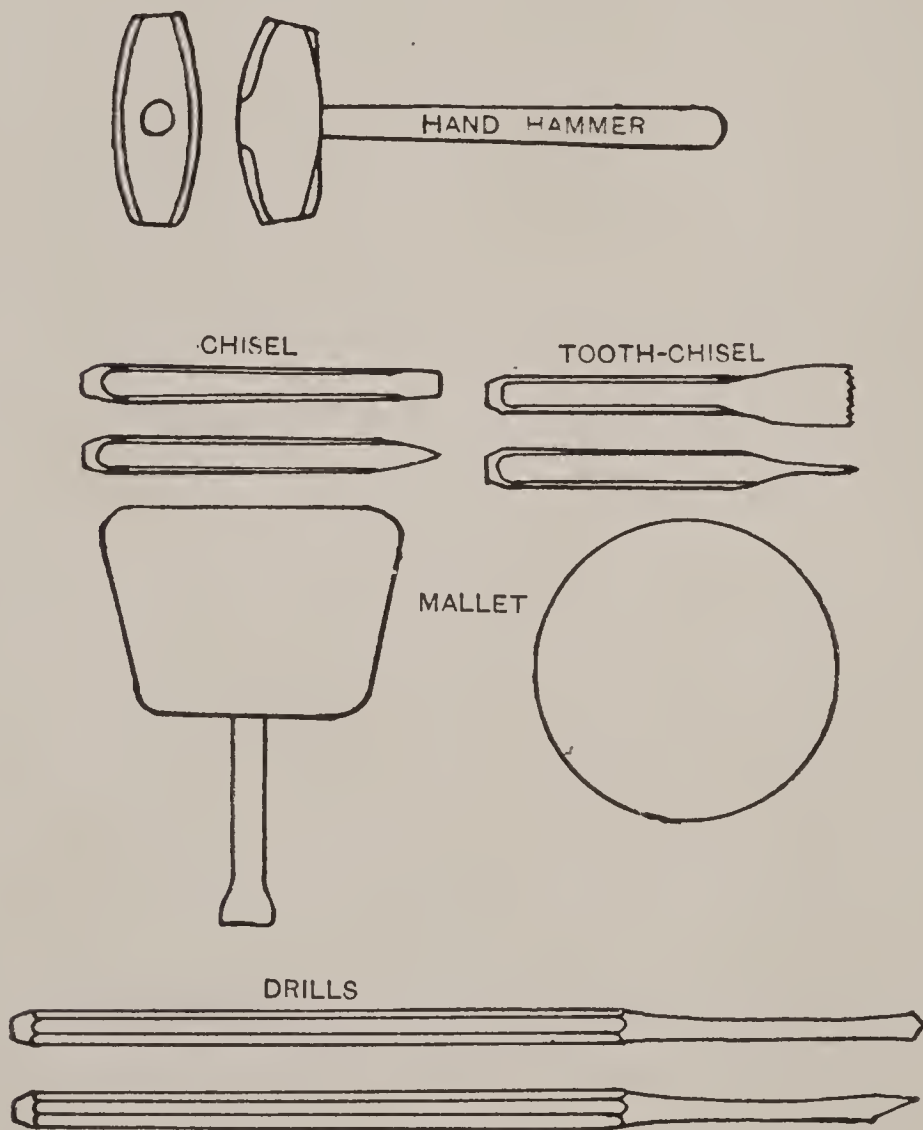

FIG. 7.

The tool is in two parts, which are held together by the bolts which hold the chisels. This tool is used for giving a finish to the surface of stones.

3. All of the above mentioned are two-handed, or require

both hands of the workman to use them. The remaining tools to be described require the use of only one hand for each.

The hand hammer and mallet are used for chiselling hard and soft stones respectively. The pitching-chisel is used to make a well-defined edge on the face of a stone, and the point for finishing a surface. The chisel and tooth-chisel are used for cutting drafts or margins on the face of stones, but the latter is used only on marbles and sandstones. The splitting-chisel and plug are used for splitting stratified and unstratified stone respectively.

In architectural carving a variety of chisels of different forms are used, for most of which no specific name exists.

For extensive operations machinery replaces many of the hand tools above described. The chief ones are the saw and

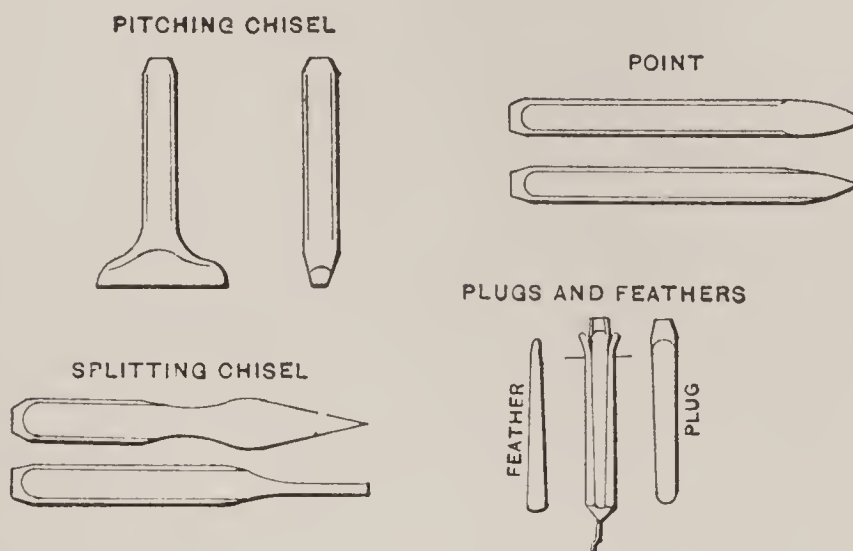

FIG. 8.

planer, the latter being a machine very similar to a metal planer. By simply changing the cutting tool a great variety of surfaces may be formed. A certain amount of hand-work, however, always remains to be done on nearly all stones.

ART. 2.—STONES CLASSIFIED ACCORDING TO FINISH.

4. All stones used in building come under one of three classes, viz. :

I. Rough stones that are used as they come from the quarry.

II. Stones roughly squared and dressed.

III. Stones accurately squared and finely dressed.

In practice the line of separation between them is not very distinctly marked, but one class gradually merges into the next.

5. I. **Unsquared Stones or Rubble.**—This class covers all stones which are used as they come from the quarry without other preparation than the removal of very acute angles, and excessive projections from the general figure. The term “backing,” which is frequently applied to this class of stone, is inappropriate, as it properly designates material used in a certain relative position in a wall, whereas stones of this kind may be used in any position.

6. II. **Squared Stones.**—This class covers all stones that are roughly squared and roughly dressed on beds and joints. The dressing is usually done with the face hammer or the axe, or in soft stones with the tooth-axe. The distinction between this class and the third lies in the degree of closeness of the joints which is demanded. Where the dressing on the joints is such that the distance between the general planes of the surfaces of adjoining stones is one half inch or more, the stones properly belong to this class.

Three subdivisions of this class may be made, depending on the character of the face of the stone :

(a) *Quarry-faced* stones are those whose faces are left untouched as they come from the quarry.

(b) *Pitch-faced* stones are those on which the arris is clearly defined by a line beyond which the rock is cut away by the pitching-chisel, so as to give edges that are approximately true. (Fig. 20.)

(c) *Drafted* stones are those on which the face is surrounded by a chisel-draft, the space inside the draft being left rough. Ordinarily, however, this is done only on stones in which the cutting of the joints is such as to exclude them from this class.

In ordering stones of this class the specification should always state the width of the bed and end joints which are expected, and how far the surface of the face may project beyond the plane of the edge. In practice the projection varies between 1 inch and 6 inches. It should also be specified whether or not the faces are to be drafted.

7. II. Cut Stones.—This class covers all squared stones with smoothly dressed beds and joints. As a rule all the edges of cut stones are drafted, and between the drafts the stone is smoothly dressed. The face, however, is often left rough when the constructions are massive.

Rough-pointed.—When it is necessary to remove an inch or more from the face of a stone, it is done by the pick or heavy points until the projections vary from $\frac{1}{2}$ to 1 inch. The stone is then said to be rough-pointed. This operation precedes all others in dressing limestone and granite.

Fine-pointed.—If a smoother finish is desired, rough-pointing is followed by fine-pointing, which is done with a fine point. It is only used where the finish made by it is to be final, and never as a preparation for final finish by another tool.

Crandalled.—This is only a speedy method of pointing, the effect being the same as fine-pointing, except that the

dots are more regular. The variations of level are about $\frac{1}{8}$ inch, and the rows are made parallel. When other rows at right angles to the first are introduced, the stone is said to be cross-crandalled.

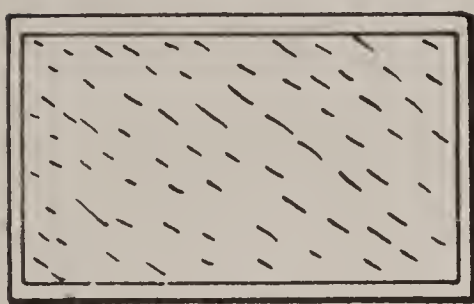

FIG. 9.



FIG. 10.



Axed or Pean-hammered, and Patent-hammered.—These two vary only in the degree of smoothness of the surface

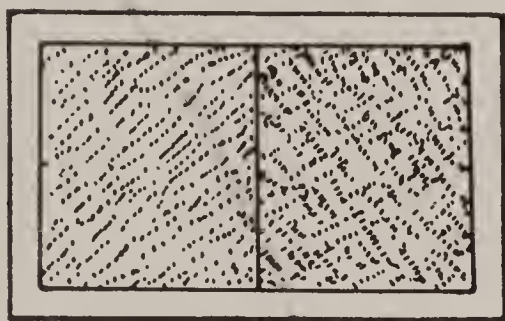

FIG. 11.



FIG. 12.

which is produced. The number of blades in a patent hammer varies from 6 to 12 to the inch, and in precise specifications the number of cuts to the inch must be stated, such as 6 cut, 8 cut, 10 cut, 12 cut. The effect of axing is to cover the surface with chisel-marks which are made parallel as far as possible. Axing is a final finish.

Tooth-axed.—The tooth-axe is practically a number of points, and it leaves the surface of the stone in the same condition as fine-pointing. It is usually, however, only a preparation for bush-hammering, and the work is then done without regard for effect so long as the surface of the stone is sufficiently levelled.

Bush-hammered.—The roughnesses of a stone are pounded

off by the bush-hammer, and the stone is then said to be "bushed." This kind of finish is dangerous on sandstone, as experience has proved that sandstone thus treated is very apt to scale.

In dressing limestone which is to have a bush-hammered

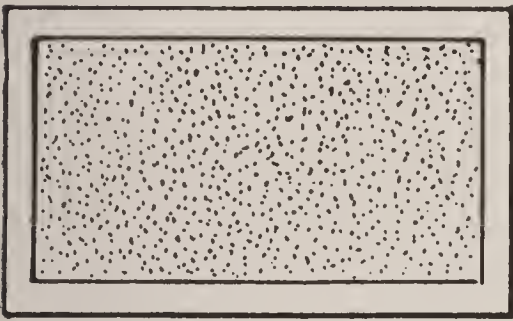

FIG. 13.

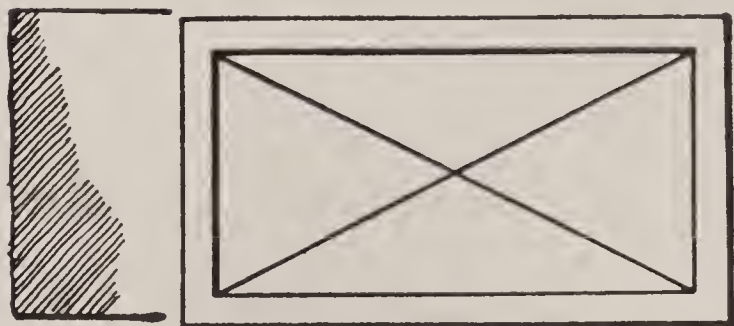

FIG. 14.

finish the usual sequence of operations is: 1st, rough-pointing; 2d, tooth-axing; 3d, bush-hammering.

Rubbed.—In dressing sandstone and marble it is very common to give the stone a plane surface at once by the use of the stone-saw. Any roughnesses left by the saw are removed by rubbing with grit or sandstone. Such stones therefore have no margins. They are frequently used in architecture for string-courses, lintels, door-jambs, etc., and they are also well adapted for use in facing the walls of lock-chambers, and in other localities where a stone surface is liable to be rubbed by vessels or other moving bodies.

Diamond Panels.—Sometimes the space between the margins is sunk immediately adjoining them and then rises gradually until the four planes form an apex at the middle of the panel. Such panels are called diamond panels, and in the case described the panel is a sunk diamond panel. When the surface of the stone rises gradually from the inner lines of the margins to the middle of the panel, it is called a raised diamond panel. Both kinds of finish are common on bridge

quoins and similar work. The details of this method of dressing should be given in the specifications.

8. The student should take care not to confound the above-described three classes with what is termed first-, second-, and third-class masonry in railroad-engineering work. Extracts from specifications defining these classes are given in §§ 45, 53, 54.

ART. 3.—DEFINITIONS OF PARTS OF THE STRUCTURE.

9. *Face*, the front surface of a wall; *back*, the inside surface.

Facing, the stone which forms the face or outside of the wall. *Backing*, the stone which forms the back of the wall. *Filling*, the interior of the wall.

Batter.—The slope of the surface of the wall. A batter of 1 inch to 1 foot, etc., means a horizontal departure of one inch from a vertical direction for each foot of altitude.

Course.—A horizontal layer of stone in the wall. If the stones of each layer are of equal thickness throughout, it is termed regular coursing; if the thicknesses are unequal, the term random or unequal coursing is applied.

Joints.—The mortar layer between the stones. The horizontal joints are called bed-joints or simply beds; the vertical joints are sometimes called the builds. Usually the horizontal joints are called beds, and the vertical ones joints.

Coping.—A projecting course of heavy stones (generally weathered) on the top of the wall to protect it. (A coping is weathered when it is bevelled sufficiently to throw the water away from the face of the wall.)

Pointing.—A better quality of mortar put in the face of the joints to help them resist the influence of the weather.

10. Bond.—The arrangement of stones in adjacent courses. (See Art. 5.)

Stretcher.—A stone whose greatest dimension lies parallel to the face of the wall.

Header.—A stone whose greatest dimension lies perpendicular to the face of the wall.

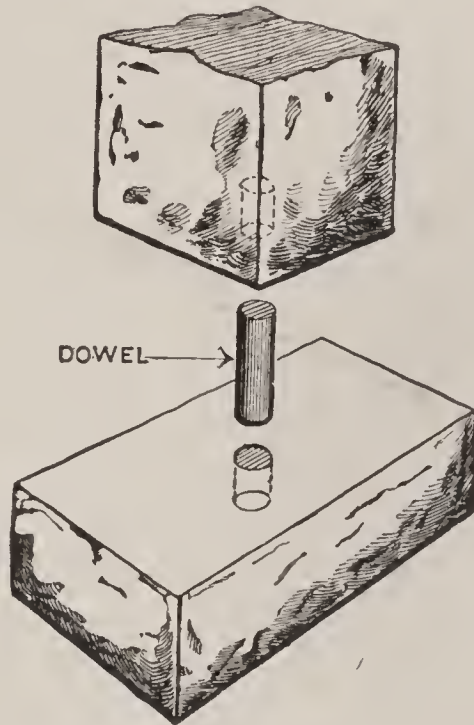

FIG. 15.

Dowels.—Pins of metal or stone which enter a hole in the upper side of one stone and also a hole in the lower side of the stone next above. They are used to prevent lateral motion between two stones. (Fig. 15.)

Cramps.—Metal bars having the ends turned at right angles to the body of the bar, which enter holes in the upper sides of adjacent stones. (Fig. 16.)

Quoin.—A corner-stone. A quoin is a header for one face, and a stretcher for the other. (Fig. 17.)

ART. 4.—CLASSIFICATION OF MASONRY.

II. As the term stone masonry includes properly all classes of construction in stone which require the employment of skilled mechanics or masons, any class of masonry

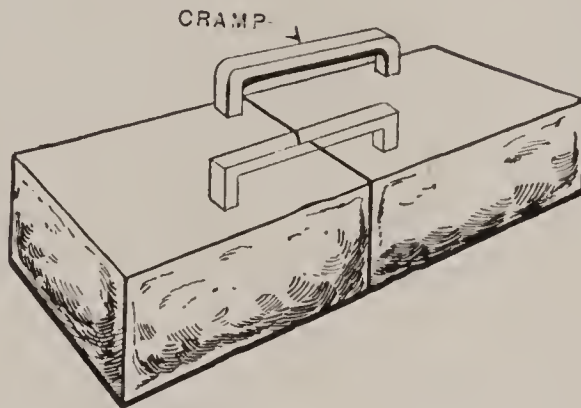

FIG. 16

may be laid dry, in lime mortar or in cement mortar, at will. On this point specifications should always be precise.

12. **Rubble Masonry.**—This is composed of unsquared stones. It is divided into: *Uncoursed Rubble* (Fig. 17), laid

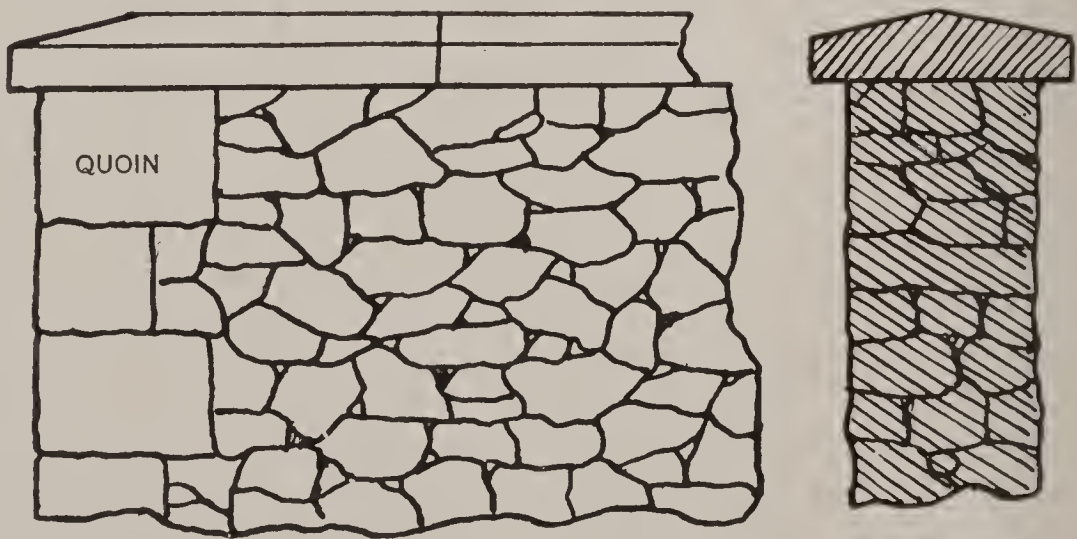

FIG. 17.

without any attempt at regular courses, and *Coursed Rubble* (Fig. 18), levelled off at specified heights to a horizontal surface. The stone may be required to be roughly shaped with

the hammer, so as to fit approximately; it is then called squared rubble.

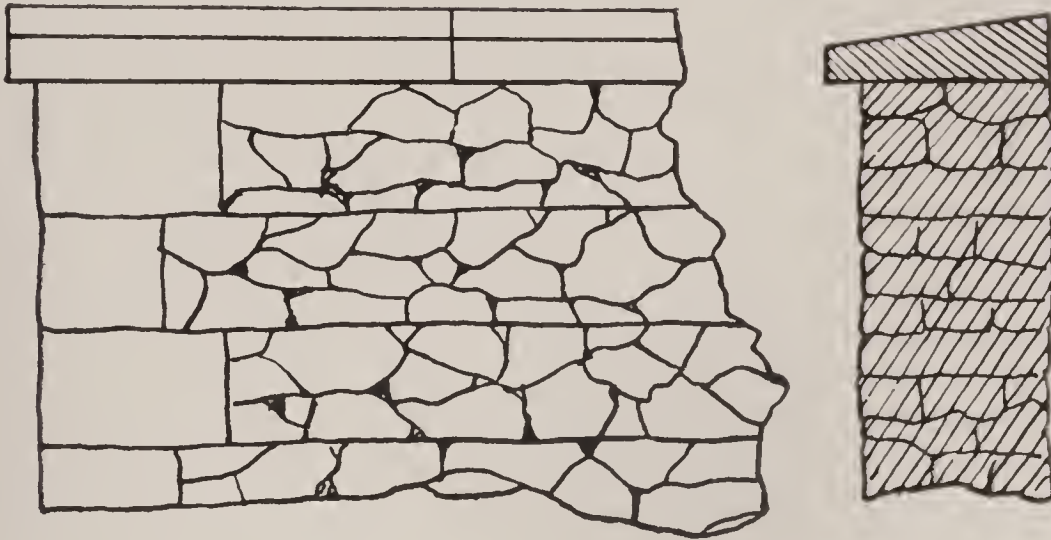
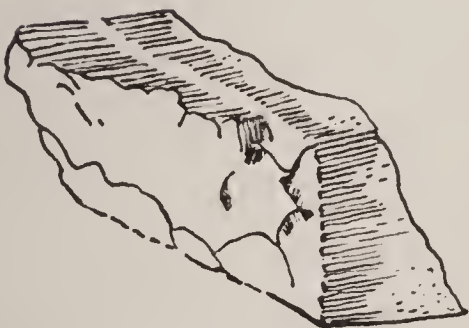

FIG. 18.

13. Squared-stone Masonry.—According to the character of the face, this is classified as *Quarry-faced* (Fig. 19) or as *Pitch-faced* (Fig. 20). If laid in regular courses of



FIGS. 19, 20.

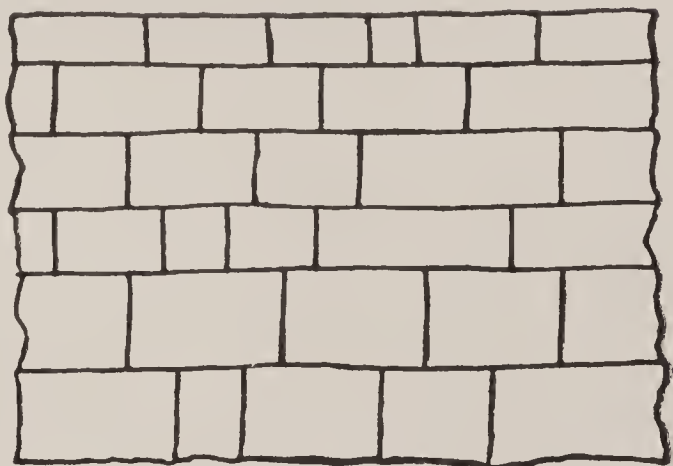

FIG. 21.

about the same rise throughout, it is *Range-work* (Fig. 21). If laid in courses that are not continuous throughout the length of the wall, it is *Broken Range-work* (Fig. 22). If not

laid in courses at all, it is *Random-work* (Fig. 23), and this is generally to be expected of this kind of masonry unless the specifications call for *Range-work*. This style of masonry is called *Block in Course* by the English. In quarry-faced and

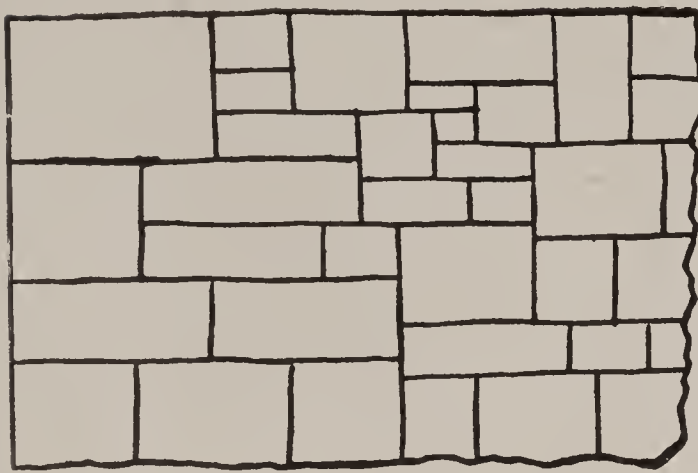

FIG. 22.

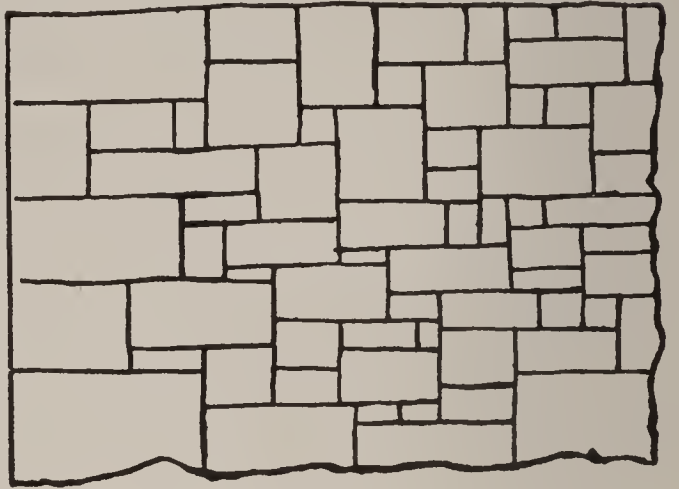

FIG. 23.

pitch-faced masonry, quoins and the sides of openings are usually hammer-dressed. This consists in removing projections so as to secure a rough-smooth surface, and is done with the face-hammer, the plain axe, or the tooth-axe. This work is a necessity where door or window frames are inserted, and it greatly improves the general effect of the wall if used wherever a corner is turned.

14. Ashlar Masonry.—This is equivalent to “cut-stone masonry,” or masonry composed of any of the various kinds

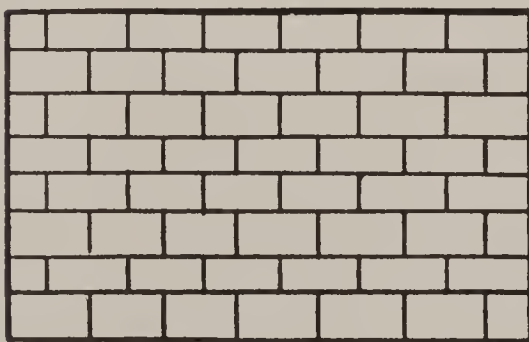

FIG. 24.

of cut stone mentioned above. As a rule the courses are continuous (Fig. 24), but sometimes they are broken by the introduction of smaller stones of the same kind, and then it is called *Broken Ashlar* (Fig. 25). If the stones are less than one foot in height, the term *Small Ashlar* is proper. The term *Rough Ashlar* is sometimes given to squared-stone masonry, either “quarry-faced” or “pitch-

faced," when laid as *range-work*, but it is believed that it is more logical and more expressive to call such masonry "squared range-work." From its derivation, ashlar apparently means large square blocks, but practice seems to have made it synonymous with "cut stone," and this secondary meaning has been retained for convenience.

Dimension-stones are cut stones all of whose dimensions have been fixed in advance. If the specifications for ashlar

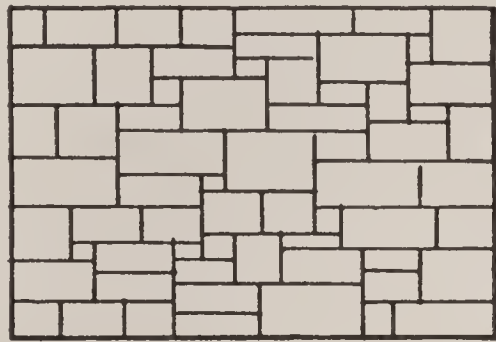
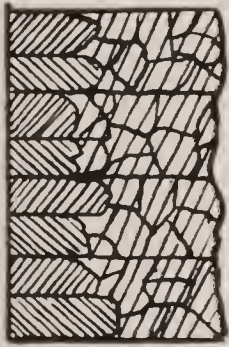

FIG. 25.

masonry are so written as to prescribe the dimensions to be used, it will not be necessary to make a new class of such stones.

Range-work, whether of squared stones or of ashlar, is usually backed up with rubble masonry, which in such cases is specified as Coursed Rubble.

Whatever terms are employed in common use to various classes of masonry, it is not safe to trust to them alone in preparing specifications for construction, but every specification should contain an accurate description of the character and quality of the work desired. Whenever practicable, samples of such kind of cutting and masonry should be prepared beforehand, and exhibited to the persons who propose to undertake the work.

ART. 5.—STRENGTH OF MASONRY.

15. The strength of masonry will depend on the size of the blocks, the accuracy of the dressing, the bond, and the quality of the mortar.

16. **Size of Stone.**—The size of the blocks varies with the nature of the stone and quarry.

Some stones are strong enough to be used in any size, while others are limited by certain proportions of length, breadth, and thickness.

A common rule, for ordinary stone, is to make the breadth at least equal to the thickness, and seldom greater than twice this dimension, and to limit the length to within three times the thickness. When the breadth or the length is considerable in comparison with the thickness, there is danger that the block may break if any unequal settling or unequal pressure should take place. As to the absolute dimensions, the thickness is generally not less than one foot nor more than two; stones of this thickness with the relative dimensions just laid down will weigh from 1000 to 8000 lbs., allowing, on an average, 160 lbs. per cubic foot. Such a weight requires considerable effort of both men and machinery to set it in place.

17. **Accuracy of Dressing.**—Accurate dressing is essential for first-class work. If the individual blocks fit well on each other, the pressure is equalized, and cracking from this cause avoided. One of the objects of the mortar between the blocks is to equalize the pressure, and it will thus be seen that the less attention is paid to dressing the better the quality of the mortar should be. Many of the largest buildings of antiquity were erected without the use of mortar, but so well were the stones fitted together that the structures

stood until overthrown by violence. Before finally placing a block of cut stone, a trial should be made to see that it fits properly.

18. Bond.—In stonework of any kind it is of the utmost importance to secure a good bond.

Headers should in all cases extend into the wall two thirds of its thickness, and preferably entirely through the wall from front to back. The number of headers in a given space varies much with the class of work. *Flemish* bond, consisting of alternate headers and stretchers, presents the best appearance and is probably as strong as any other plain bond. In foundation-work there should not be less than one header for every five square feet of surface of wall.

The vertical joints of the blocks of each course alternate with the vertical joints of the courses above and below it, or *break joints* with them. The vertical joints of one course are not to be less than four inches on one side of those in the next course, and the headers should rest as nearly as possible on the middle of the stretchers in the course below. In important work the proportion of headers, limiting sizes of stones, joints, etc., are always specified.

The mean thickness of a rubble wall should not be less than one sixth of the height; in the case of a dry stone wall the thickness should never be less than two feet.

The largest stones should be used for the foundation course.

Stratified stone should be laid on its *natural bed*, i.e., so that the direction of pressure comes at right angles to the direction of the laminæ.

CHAPTER II.

STONE-CUTTING AND MASONRY.

ART. I.—DEFINITIONS.

19. STEREOTOMY, as applied to stone-cutting, is the art or science which teaches how to make drawings, patterns, levels, etc., by which the mason may shape blocks of stone which when fitted together form a predetermined whole.

20. The stone structures treated of in these limits may be divided into two general classes :

1st, those having plane surfaces only ; and, 2d, those having plane and curved surfaces. The second class may be variously subdivided as structures with developable surfaces, with warped surfaces, and with surfaces of double curvature.

In engineering work structures of the first class predominate, and in architectural work those of the second. Examples of the first class may be found in retaining-walls, wing-walls, culverts, piers, canal-locks, buttresses, and fortifications ; and of the second class in piers, arches, vaults, domes, towers, aqueducts, etc. Numerous engineering structures and buildings show examples of both classes. A sharp division is therefore neither necessary nor desirable, and no effort has been made in these pages to keep them separate, except in the theoretic examples.

21. The first operation in all stone-cutting is to form the joints of one surface, and from these all the other bounding

planes of the finished stone are derived (Fig. 26). A line is first drawn around the stone and the joints either pitched off to this line with the pitching-chisel, as in Fig. 20, or a chisel-draft is sunk all around the face until the line is reached (Fig. 27). The rough projections of the central portion are then



FIG. 26.



FIG. 27.

brought to the plane of the margin by means of chisel and crandall, and finished according to specifications.

22. Directing-instruments.—These are of three kinds.—*patterns*, *templets*, and *bevels*,—and must of course all be full size.

Patterns show the forms of plane or of developable surfaces, and in the latter case are made of flexible material.

Templets give the forms of required edges or other distinguishing lines of a surface. A pattern is used to lay out the *relative* position of the edges, whereas a templet defines any particular edge or edges.

Bevels show the diedral angles between surfaces. The common carpenter's square is a special form of bevel, and the straight-edge a special form of templet.

Thus in Fig. 28 patterns would give the outline of the faces marked *A*, *B*, and *C*, and a bevel or templet, or both, might be used for *D*.

23. It is the place of the engineer or architect to supply the stone-cutters with such drawings as will enable them to make all the necessary directing-instruments. In practical

work it is therefore not customary to make such detailed drawings as shown here for some of the simpler examples; but in order that the student may know to what extent to go

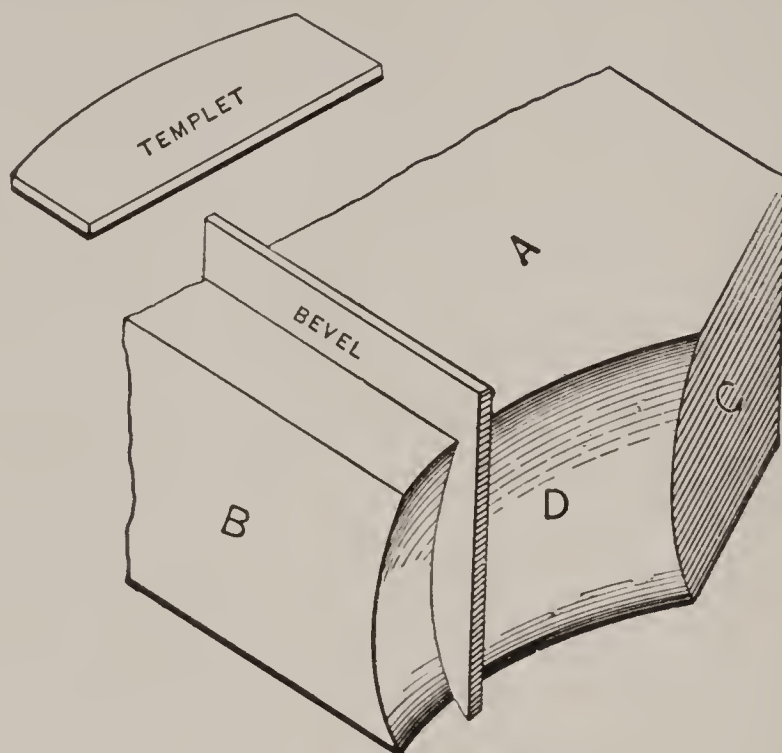
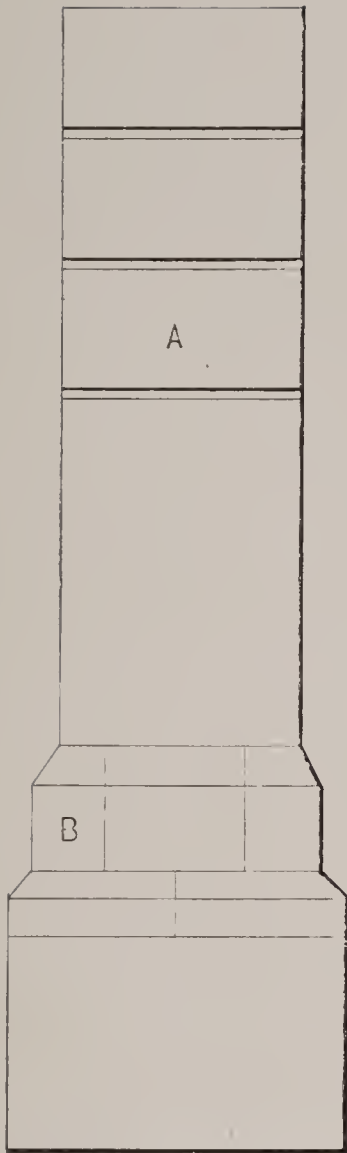

FIG. 28.

into detail he must himself know how to make these details from the drawings.

The plates, which we will now discuss, fully illustrate this point.

PLATE 1
GOTHIC BUTTRESS



FRONT ELEVATION

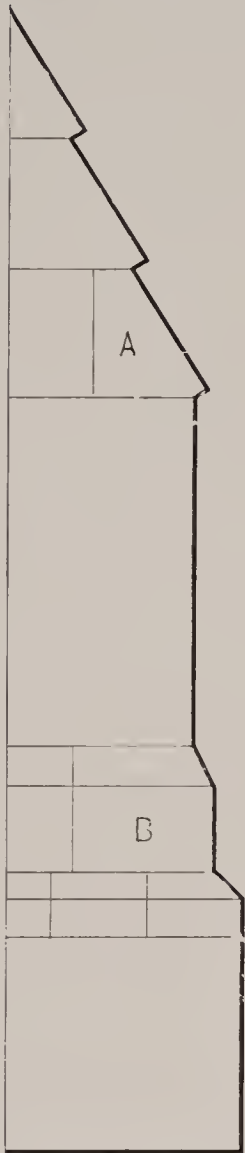

SIDE ELEVATION

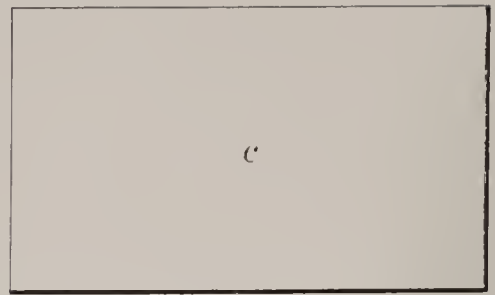

c

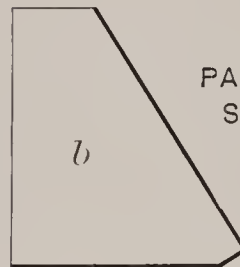

b

PATTERNS OF
STONE AT A

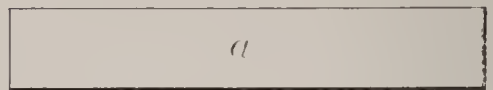

a

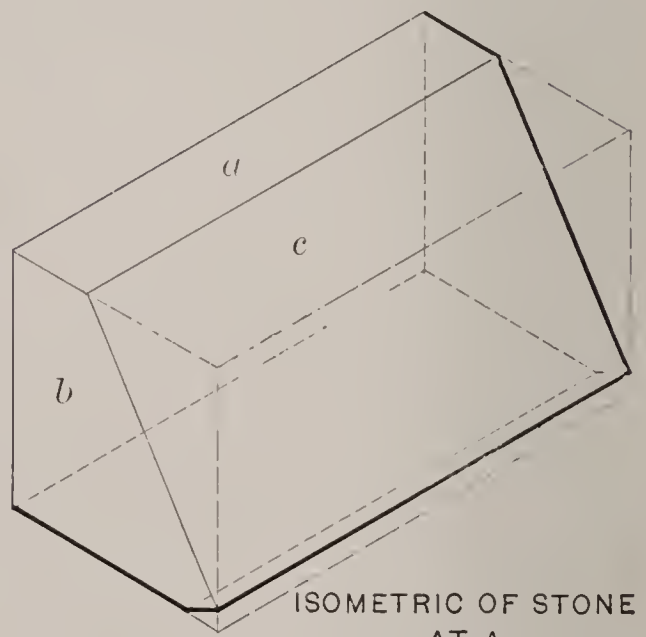

ISOMETRIC OF STONE
AT A

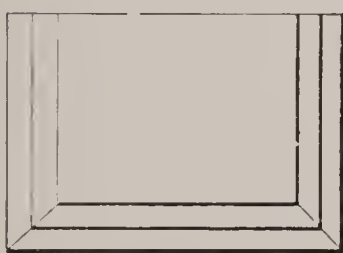

PLAN AT BASE

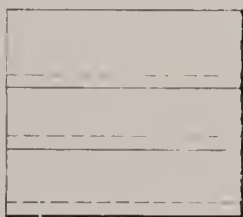

PLAN AT CAP

Scale of Plans
and Elevations

0 1 2 3 Feet

Scale of Patterns
and
Isometric of Stone

0 1 2 Feet

ART. 2.—GOTHIC BUTTRESS.

PLATE I.

24. Plate I illustrates a simple Gothic buttress, examples of which may be seen on the walls of many churches.

Since the corresponding points on the various figures bear the same letters, the student should have no difficulty in reading the drawing. For the sake of clearness a horizontal section at the base is shown, and another just below the cap. The stone *A*, of which the details are drawn, is termed a *kneeler*, and the manner in which it serves to support the coping, or cap, is evident. The details show an isometric view of the stone *A*, and patterns of the different faces. The size of the stone in the rough is indicated by the broken line on the isometric. In practice these patterns are made full size and cut out of paper, cardboard, or zinc.

25. The method of working in this case would be about as follows: Having cut the rough block of stone to a prism of nearly the desired dimensions, as explained above (§ 21), the face *a* is marked out from its pattern and brought to a plane; and the back of the stone and the two faces marked *b* worked at right angles to *a*.

The surfaces *b* are next marked, and *c* roughly cut into shape; *b* is dressed, drafts run around the edges of *c*, and its surfaces finally worked. The bottom is now easily dressed to the proper plane, and the stone is ready to hoist into place.

26. For a working drawing the details shown on this plate would be omitted, because the foreman of the masons

could readily make the patterns himself from the general drawings for such a simple case.

27. Exercises.—1. Draw an isometric view and the necessary patterns of the stone *B*.

2. Draw a buttress similar to the one shown on Plate I against a wall 3 ft. thick at the base, 13 ft. high; batter of face of wall 1 inch per foot, height and dimensions of base of buttress as in illustration, batter of its front 1 inch per foot and its sides $\frac{3}{4}$ inch per foot. Slope of top and water-tables as shown. Make the necessary details for the stones similar to *A* and *B*.

3. Take the measurements and make drawings of a buttress on some building.

PLATE 2
PERSPECTIVE OF ARCH

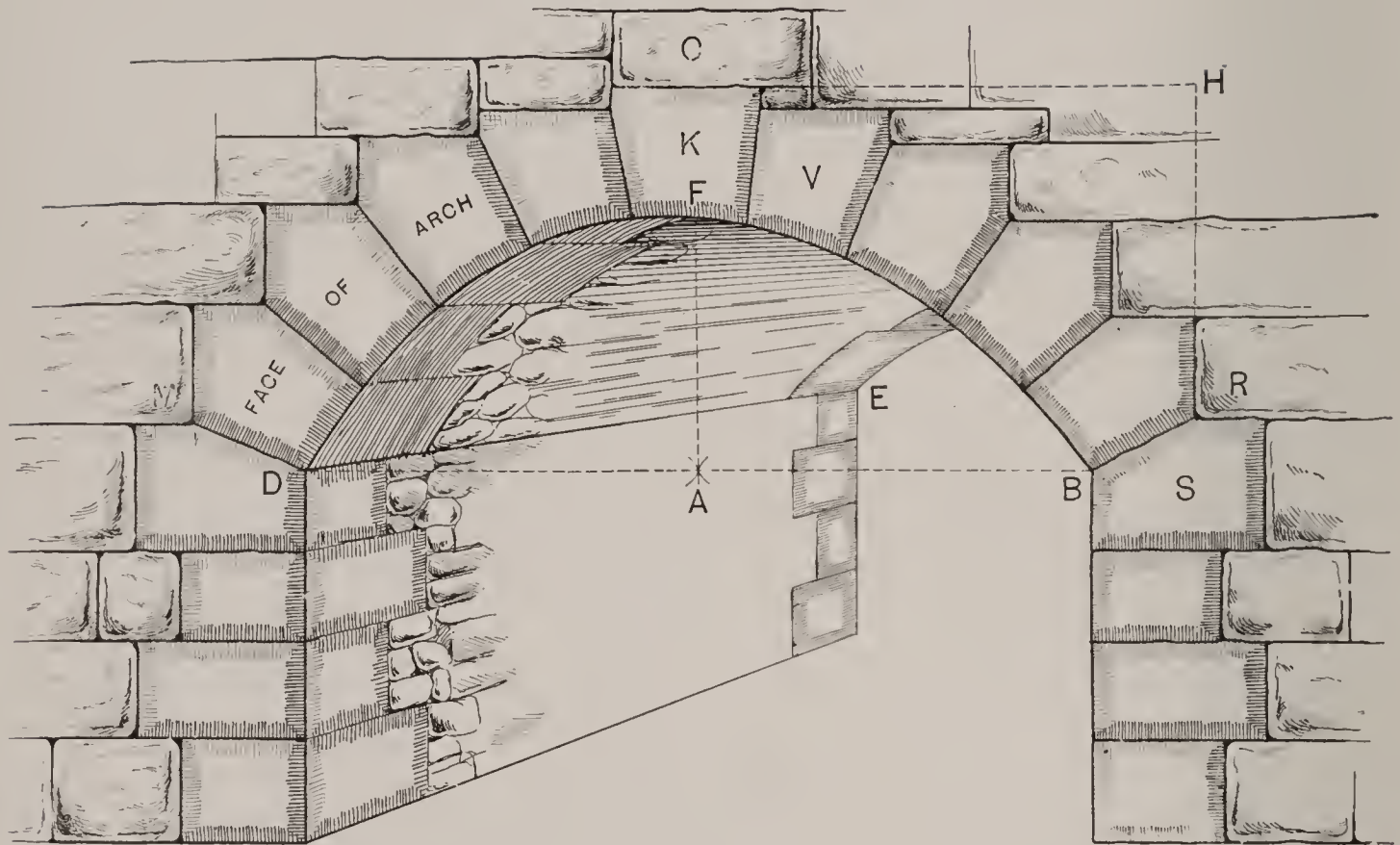

NAMES OF PARTS.

- | | |
|-----------------------------------|----------------|
| D A B=Span | A F=Rise |
| D E=Springing Line | S=Springer |
| V=Voussoirs | D F B=Intrados |
| K=Central Voussoir or
Keystone | R H C=Spandrel |
| M C R=Extrados | C R=Haunch |
| C=Crown | B R=Skewback |

ART. 3.—ARCHES.

PLATE II.

28. This plate clearly illustrates and defines the various parts of an arch. Additional definitions are:

Soffit : the concave surface of the arch.

Back : the convex surface of the arch.

Spandrel-filling : the filling in the space *CHR*.

All the definitions given for one half the arch naturally apply to the other half; thus there are two haunches, two skew-backs, etc.

String-course : a course running the length of the arch, parallel to *DE* in a right arch.

Ring-course : a course parallel to the face of the arch.

Coursing-joint : a joint between adjoining string-courses. Also called *Bed-joint*.

Heading-joint : a joint between adjoining ring-courses.

Arch-shedding : all of the arch masonry of the arch proper, except the face-voussoirs.

The face of the arch is also called *The Head*, and the face-voussoirs *Ring-stones*.

PLATE III.

29. On Plate III are shown methods of constructing the principal styles of arches used in architecture and engineering.

The style of the arch to be employed is governed by the style of architecture employed, the purpose it is to serve, and the local conditions. The full-centred or semicircular arch (Fig. 1) is the strongest, but is often replaced by the segmental (Fig. 6), owing to limited space for the rise. The elliptic arch (Fig. 4) is generally considered the most graceful; and the Gothic and Tudor arches (Figs. 3 and 5) are employed chiefly in certain styles of architecture.

The Gothic or pointed arch, shown in Fig. 3, is drawn by striking intersecting arcs from a, a as centres, with the span as radius.

30. If the intrados is to be an oval and its rise is to be not less than one third the span, a three-centred oval will generally give a curve of form more pleasing to the eye than one of a greater number of centres.

If we assume the radius of the curve at the springing-lines, the general construction of a three-centred oval is as follows:

On the span and rise set off at AD and EF a distance less than the rise HF . Draw DE , bisect it by a perpendicular, and extend this perpendicular to meet FH produced in C . Then will C and D be two of the required centres.

An infinite number of ovals may be thus constructed for the same span and rise, and a third condition may be imposed

PLATE 3
MASONRY ARCHES

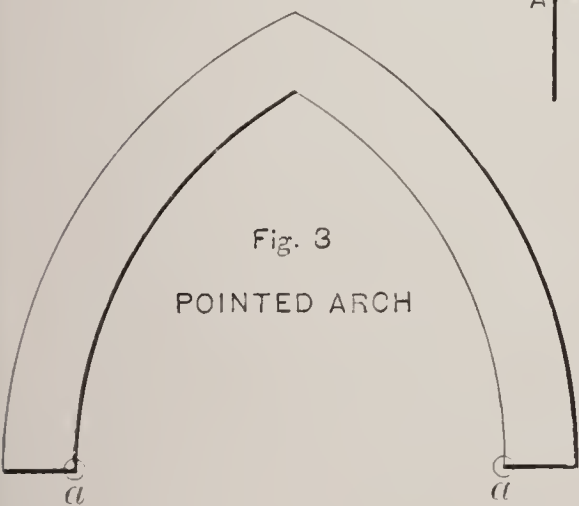
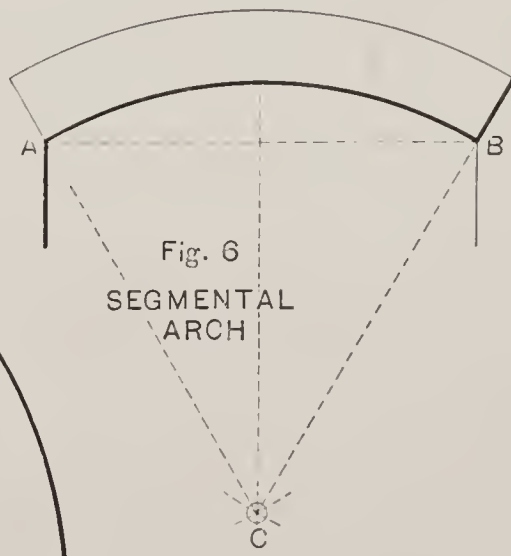
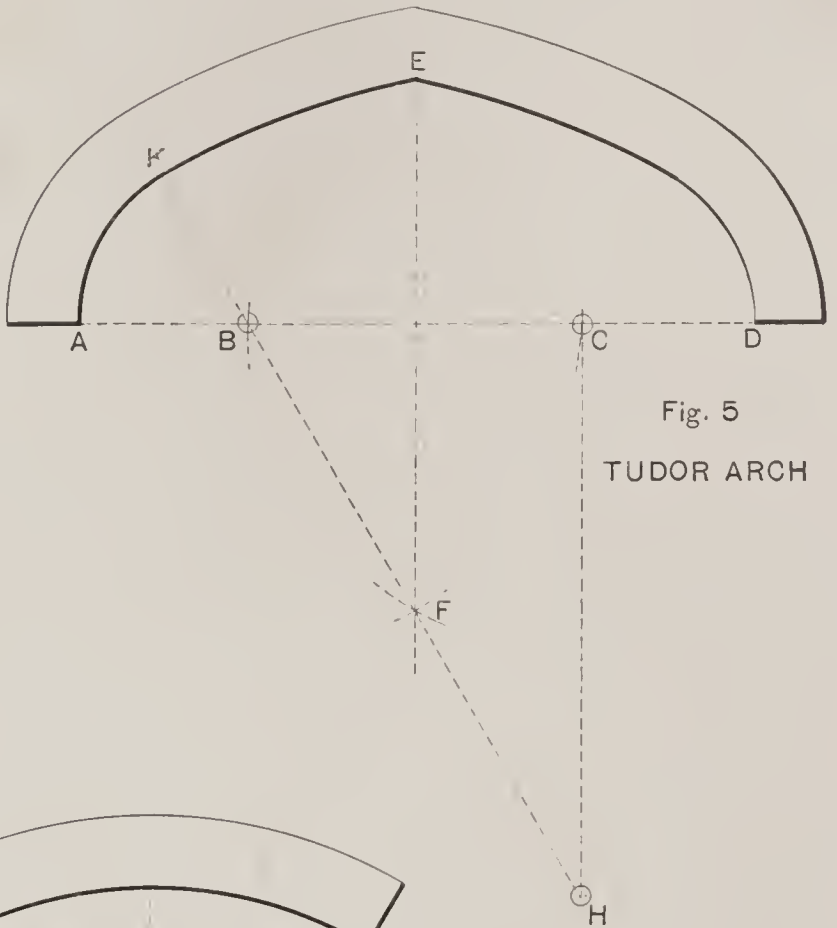
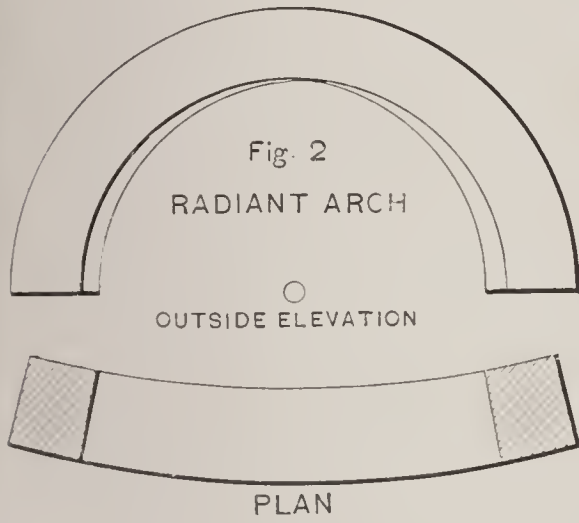
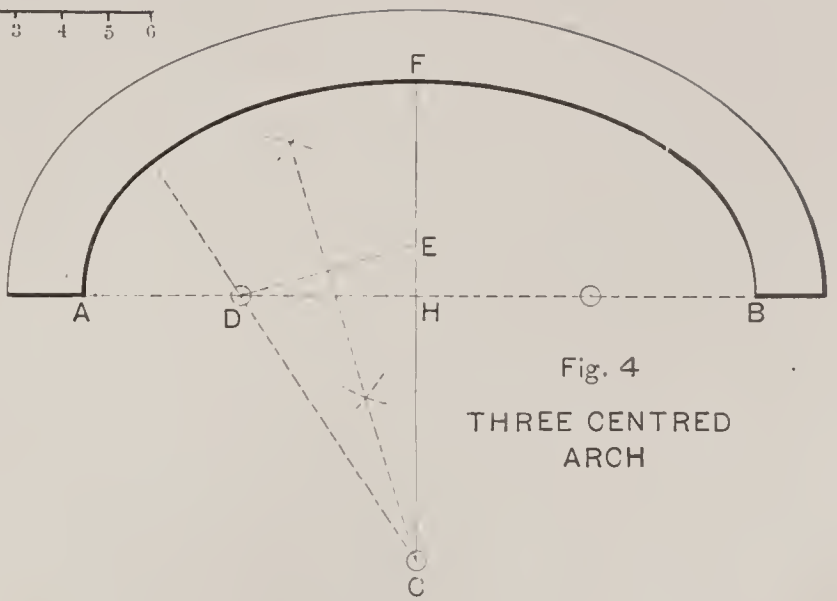
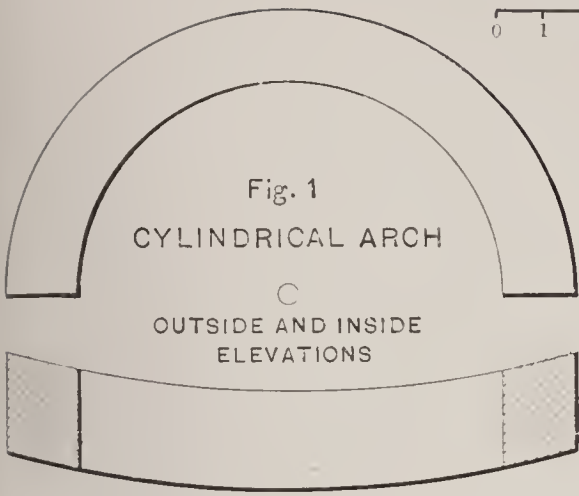
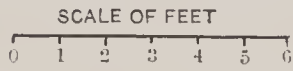

if it be desired to make a determinate solution. (See Wheeler's "Civil Engineering," p. 258.)

31. The four-centred Tudor arch (Fig. 5) may be constructed as follows: Divide the span AD into four equal parts, AB , BC , etc. From B and C as centres, with radius equal to BC , describe arcs intersecting in F . Draw BF and extend it to meet a perpendicular to AD through C . With B as centre and radius AB describe AK , and with H as centre and radius HK describe KE . Similarly for the other half of the arch.

The segmental arch (Fig. 6), such as is used to span openings over doors and windows, is constructed on the equilateral triangle ABC , having a side equal to the span.

PLATE IV.

32. The Recessed Flat Arch, or Plate-band.—This form of arch is used where it is desirable to have the top of the opening present a flat surface. The bearing power of this construction is small, and any considerable weight above it is borne by a *relieving-arch* or a beam. The lintels over the doors and windows of a brick building are simple examples. This arch should not be used for spans exceeding ten feet.

Having given the necessary dimensions, the front elevation and top view are drawn. A top view is shown in place of the usual plan in order to bring out the joints of the arch. Thus the line $f-g$ shows a joint on the back of the arch; $h-i$ on the elevation corresponds to $h-i$ on the top view. There being a shoulder at i which does not appear on the elevation, and the line $i-l$ being in a vertical plane, the points cannot be lettered alike without tending to confuse. The student should draw a vertical section through the keystone, which will materially aid him to a better understanding of the structure.

The isometric of the stone A may be drawn as follows: From any convenient point, as O , draw the usual co-ordinate axes, $O-a$, $O-2$, and $O-13$. Lay off $O-2$ equal to the width of the stone, equal to $12-2$ on the elevation. Draw the front of the stone, all of whose lines except $4-5$ show in their true size, and may therefore be taken from the elevation. Lay off $1-14$ and $14-15$, equal to $1-14$ and $14-8$ respectively on the top view, and draw $1-15$. $15-16 = 8-9$, $16-12 = 15-12$, and $12-13 = 10-13$. As a check $O-13$ should equal $n-O$.

PLATE 4
RECESSED FLAT ARCH

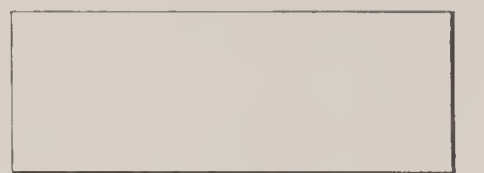
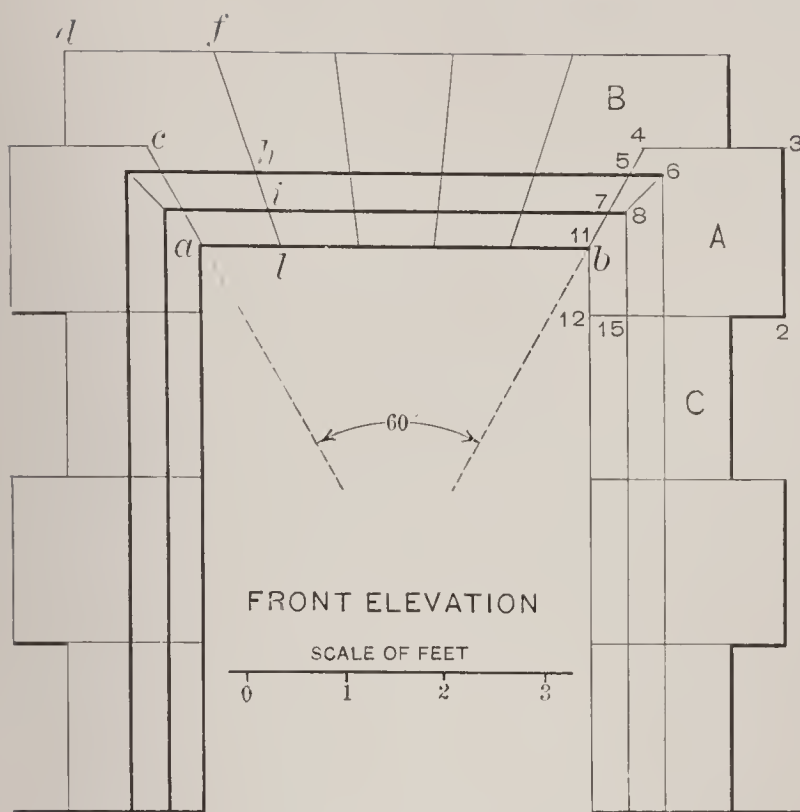

PATTERNS FOR
JOINT A-B

SCALE OF FEET

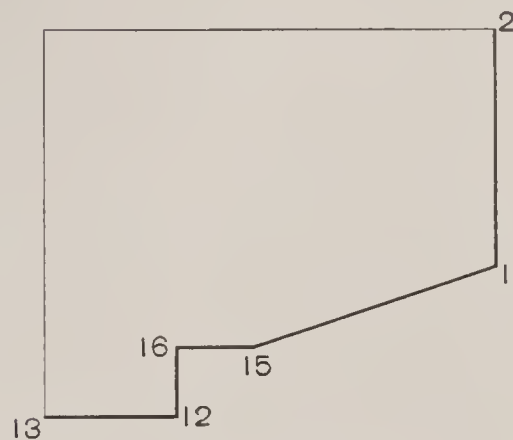
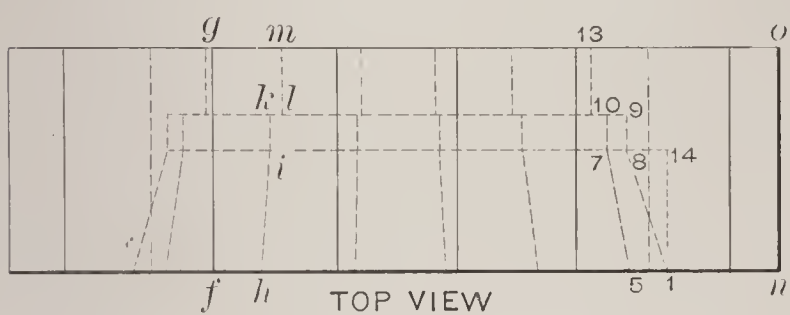
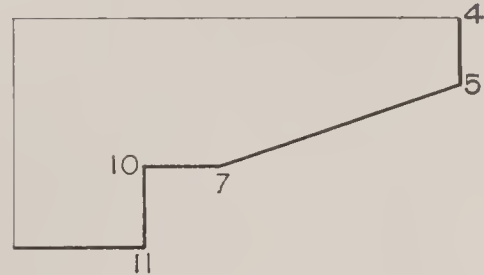
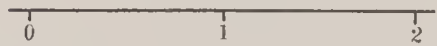

PATTERNS FOR
JOINT A-C

SCALE OF FEET

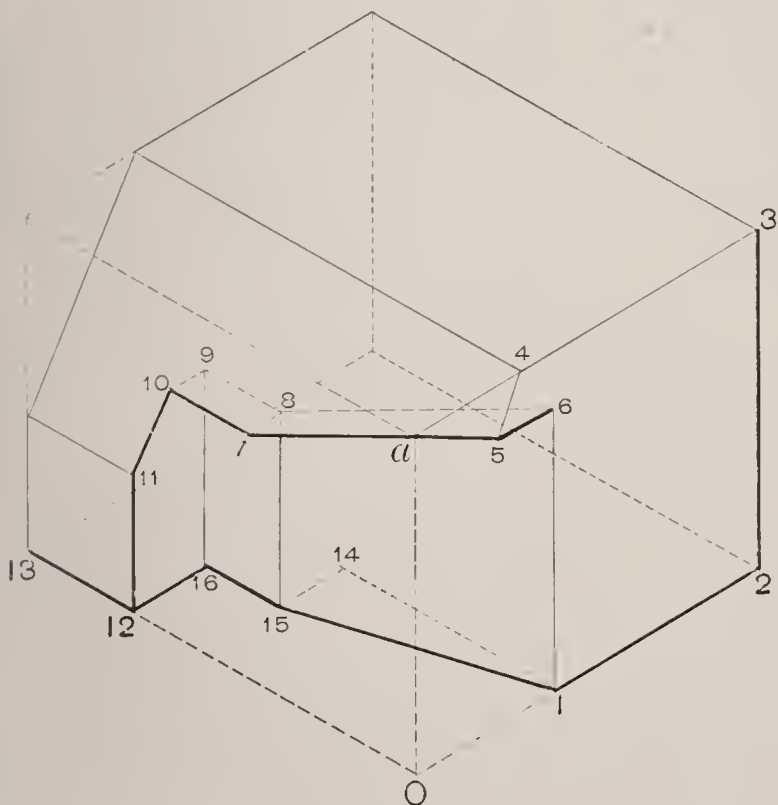
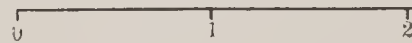

From the points 13, 12, 16, and 15 draw the verticals as taken from the elevation, and the drawing is readily completed. The patterns, being numbered to correspond to the numbering on the other figures, need no further explanation.

33. Exercises on Plate IV.—1. Draw a vertical section through the keystone.

2. Draw an isometric of, and all necessary patterns for, the keystone and the stone *B*.

3. Draw a recessed circular or pointed arched gateway of dimensions similar to the flat one shown; adding three or four stone steps to the front.

PLATE V.

34. Arches in Circular Walls.—An arch in a circular wall is a construction sometimes met in architectural and in engineering work.

It is generally avoided, owing to the difficulty of constructing it, and the not pleasing effect of the finished structure. There are instances, however, when it is necessary to use it, and an explanation of a simple case is inserted here. For the more complex cases the student is referred to Émile Lejeune's "Traité Pratique de la Coupe des Pierres."

35. Almost any form of arch may be constructed in a circular wall. Two general divisions may be noted—the cylindrical arch, and the radiant arch. The first is the ordinary arch with cylindrical intrados and extrados, whereas in the second the elements of intrados and extrados radiate from a common vertical axis. The elements are, however, in every case parallel to the springing-plane—a point which should be carefully noted, and which will readily appear from an inspection of Plate III. The outer and inner openings of the cylindrical arch are the same in size, but in the radiant arch the inner opening is smaller.

36. A cylindrical arch in a circular wall may be considered as a case of two cylinders intersecting at right angles, the axis of the one being vertical and that of the other horizontal. We will explain how to obtain all the necessary patterns, bevels, etc., have given plan, elevation, etc., of the arch.

37. Fig. 1 shows the elevation of a cylindrical circular arch and a portion of the circular wall containing it. The plan

PLATE 5
CYLINDRICAL ARCH
IN A
CIRCULAR WALL

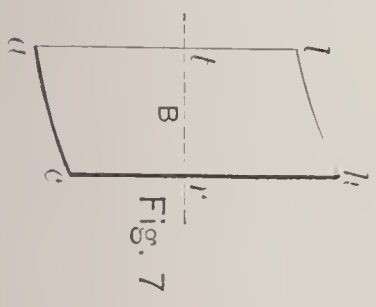
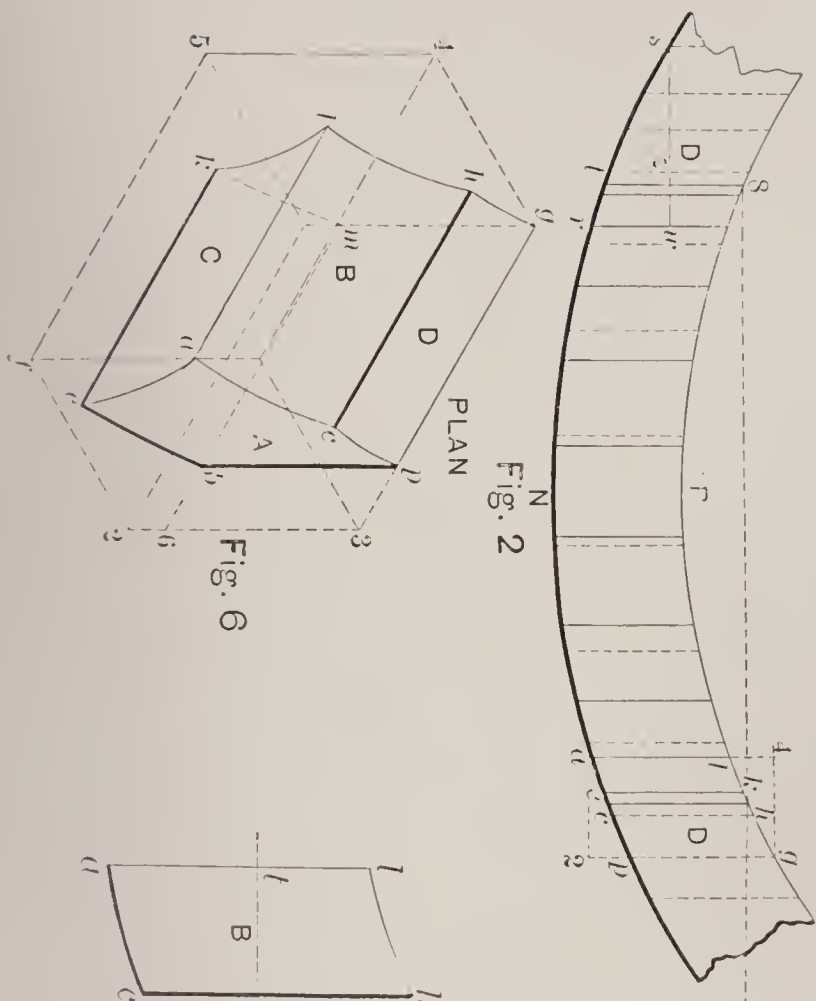
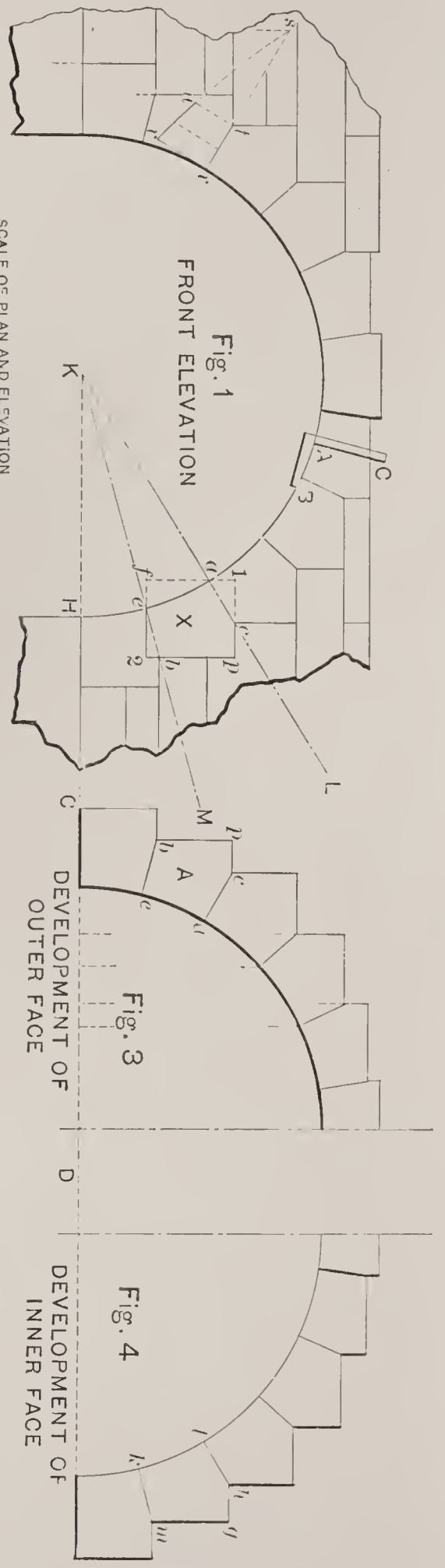

shows the joints as though the soffit were viewed from below, which is done to show its joints more plainly. Let us take some one stone, as X , and show how to derive all the patterns necessary to work its faces.

Draw first an isometric view, as Fig. 6, in order to obtain a better conception of its appearance. Briefly, this may be constructed thus: Around the elevation and plan of X draw rectangles showing the limits of the rough stone from which to work the finished block. Draw an isometric block with these dimensions, as $f-1-3-2$, etc., and on this plot the corners of the stone—remembering that three such co-ordinates are necessary to locate a point not in an isometric plane. Thus the point b requires the co-ordinates $f-2$ and $2-b$ from Fig. 1 and $2-p$ from Fig. 2; which are laid off as $f-2$, $2-6$, and $6-b$ respectively in Fig. 6.

The face A , having the curve of the wall as shown by the lines $c-p$ and $e-p$, Fig. 2, must be developed to show its true size. The developments of one half the outer and one half the inner faces is shown in Figs. 3 and 4. Set off along the line $C-D$, Fig. 3, the outer curve of the wall, by points from Fig. 2; erect ordinates at these points and project the proper heights over from Fig. 1. (See Descriptive Geometry for development of cylinder.) The pattern is now shown in its true size at $b-e-a-c-p$, Fig. 3. The corresponding one for the inner face is found on Fig. 4.

The pattern for B requires us to find the true size and appearance of the radial joints $a-c$ and $e-b$. These joints are formed by the intersection of the planes $K-L$, $K-M$, etc., perpendicular to the vertical plane of projection, with the vertical cylinder or portion of cylinder forming the wall. They are therefore arcs of ellipses, and may be shown in their true size by revolving parallel to one of the planes of projec-

tion or constructing the ellipse, having given its axes. The former method is shown here, and for clearness the corresponding stone on the left of the arch is taken. The chord $s-r$, Fig. 1, is used as an axis. When the ellipse is revolved into V , the point s remains stationary, being where the axis intersects the arc; r falls at v , a distance equal to wr , t at u , and other points similarly. $u-v$ shows the arc we want, and Fig. 7 gives the construction of the pattern—the lines $c-h$ and $a-l$ being obtained from Fig. 2.

To construct the pattern for C we must develop the under surface or soffit of the arch. If the arch were in a straight wall, its development would of course be simply a rectangular band equal in length to the semicircumference of the circle of radius $K-a$ and in width to the thickness $N-P$. But owing to the circular shape of the wall the development departs from this rectangular form, as will be shown if a chord be drawn from h to g , Fig. 2. To develop, then, lay off, by points, on the indefinite line $H-I$, Fig. 5, the length of the arch from Fig. 1, as $H-1$, $1-2$, etc., equal to $H-c$, $e-a$, etc., respectively, in Fig. 1; draw perpendiculars at these points, and project the points k , l , etc., over from Fig. 2. Through the points thus found draw the curve of the developed intrados. C shows the desired pattern. D is shown in its true size in Fig. 2.

38. At CAB , Fig. 1, is shown an arch square. It is a bevel, the arm AC of which radiates from the centre of the arch, and the arm AB is curved to the curve of the intrados, as shown on the elevation.

39. The stone X may now be worked as follows: The face $bpgm$, Fig. 6, is rectangular, and needs no further explanation. The face D at right angles to this one is also readily worked, its pattern being shown on Fig. 2. A bevel, having the

angle acp , Fig. 1, is made, and the face B worked by means of it and the pattern, Fig. 7. The soffit C is now worked by means of the arch square and the pattern $calc$, Fig. 5, this pattern being made of zinc, and bent to the proper curve on the arch square. The development A , Fig. 3, bent to the curve ap , Fig. 2, will give the pattern of A , Fig. 6, and therefore a templet for cb . A draft cb having been sunk, the face A is readily worked. The other faces are obtained similarly.

40. Exercises.—1. Draw an isometric and construct all necessary patterns and bevels for the keystone.

2. Replace the arch in the illustration by a three-centred one and make the drawings.

3. Make the drawings when the face of the arch is moulded.

ART. 4.—INTERSECTING ARCHES.

PLATE VI.

41. We will now deal briefly with the surfaces formed by the intersection of two arches.

Whenever two intersecting surfaces of the second degree (ellipse, hyperbola, parabola) have one diameter in common, their intersections lie in planes, and are consequently projected on the plane of the axes as straight lines. Two cylindrical arches having each the same rise (the spans may or may not be equal) will intersect in ellipses, and this is true whether the intersection be right or oblique. The curves thus formed by the intersection of two vaults are called groins, or groin curves.

Two general divisions of intersecting arches may be noted, forming, 1st, *The Cloistered Vault*, and, 2d, *The Groined Vault*.

The cloistered vault (Figs. 4 and 5) is formed when the arches *meet* to form a covering for a closed area, making a vaulted ceiling for a room. The groins in this case form valleys between the vaulting surfaces. The effect may be seen in any room which has a coved ceiling, i.e., one in which the walls and ceiling are connected by a curve instead of a right angle.

The groined vault (Figs. 1, 2, and 3) is formed when the arches *cross* each other, forming the vaulted passage called cross-vault (German *Kreuzgang*). Fig. 1 shows plainly how the groin curves, as *fbg*, are formed by the intersection of the

PLATE 6
GROINED
AND
CLOISTERED VAULTS

SCALE OF FEET
0 1 2 3 4 5 6 7 8 9 10

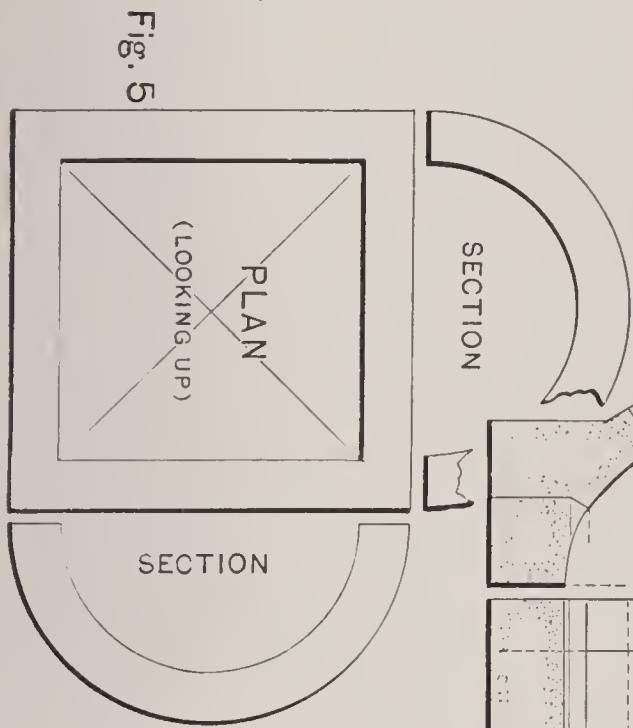
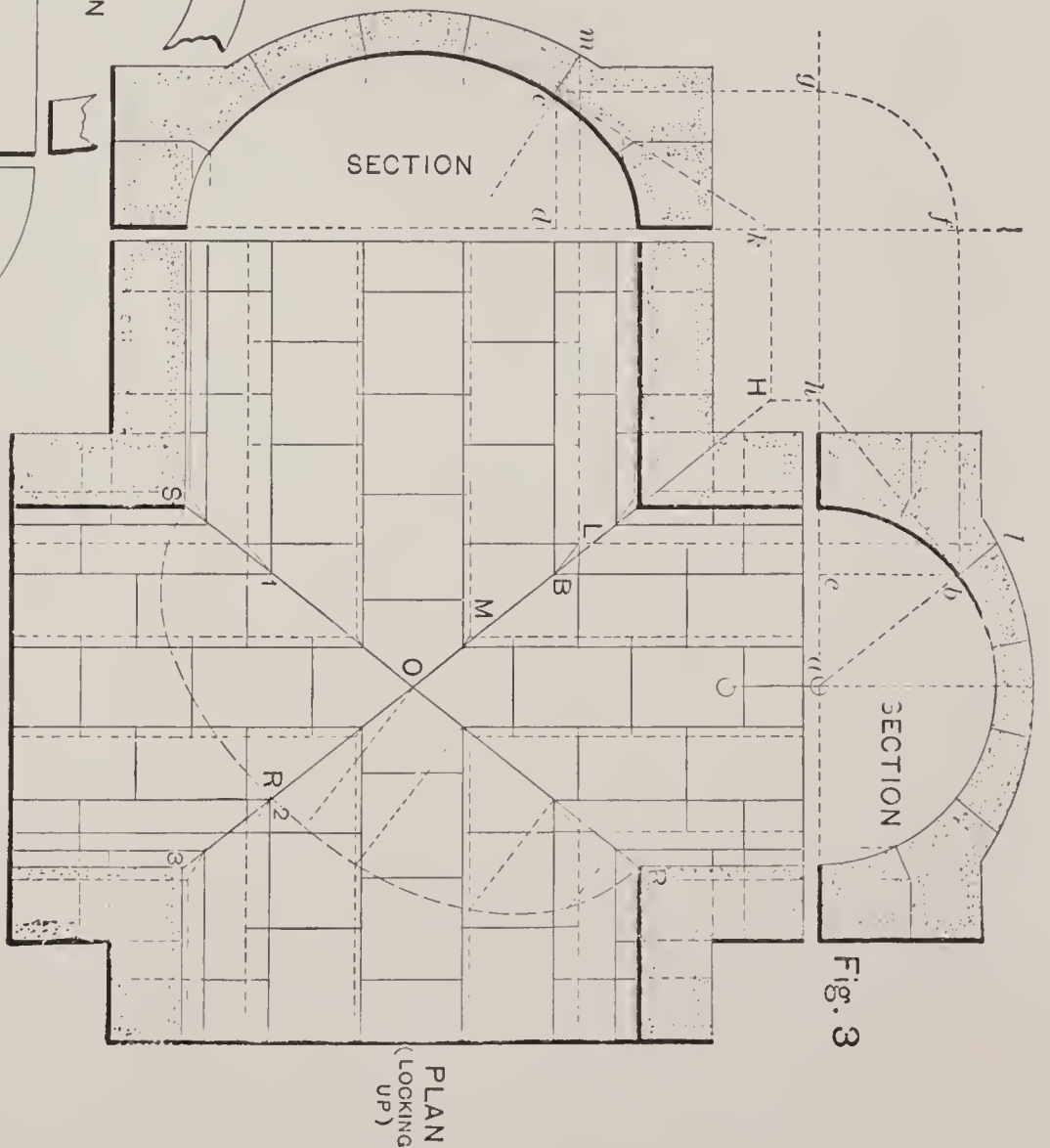
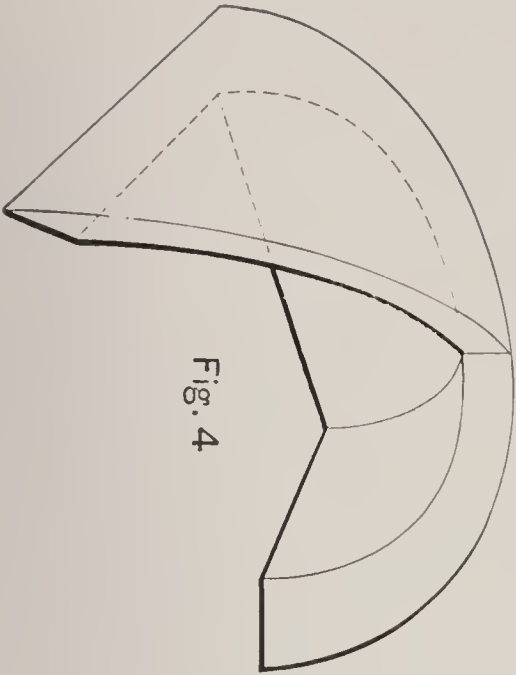
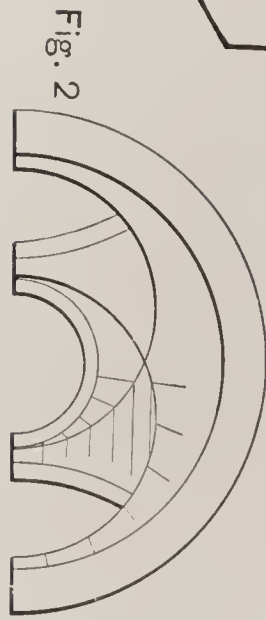
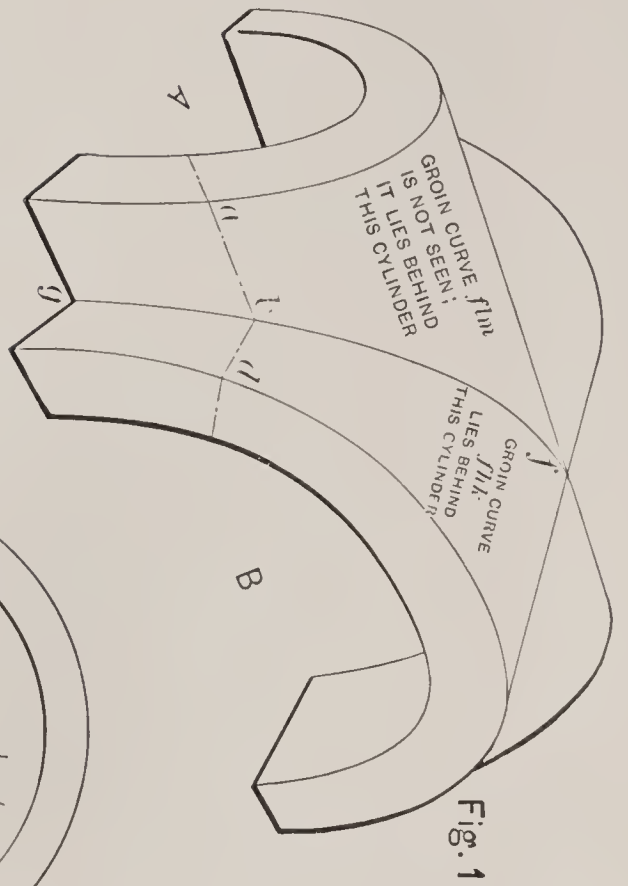

different elements, ab , db , etc. It will be seen that the groins in this case project into the passage—just the opposite from the cloistered groin. If in Fig. 1 the elements of the cylinder A lay between the groins fbg and flk and the corresponding ones to the left, and the elements of the cylinder B lay between the groins fbg and flm and the corresponding ones to the rear, the passageway would be closed and the groined vault would become a cloistered vault.

Fig. 2 shows a groined vault from below.

42. The Right Groined Vault.—Referring now to Fig. 3, let the two vaults be given as in the plan, intersecting at right angles. The joint lines of the intrados are, as in Plate V, shown as full lines, because they are of more importance than those of the extrados, which latter is frequently left unfinished. Let the right section of the one vault be a circle of radius $a-b$, radius of extrados being equal to depth of keystone plus $\frac{3}{4}$ diameter of arch. This increase of radius gives a proper thickness towards the springing of the arches. Now let us impose the conditions that corresponding points on the two arches be the same height above the springing-plane, and that all bed-joints be normal to the soffits. The joints of the circular arch—call it No. 1—will of course radiate towards the centre a of the intrados, while those of the other arch, No. 2, will be determined as follows:

First, to find the curve of the intrados of No. 2. Project the point b of No. 1 on the groin, in B ; from B draw Bc parallel to the axis of No. 2, and lay off dc equal to cb ; or project the point as shown by the dotted construction $bfgc$. Sufficient points having been thus found, the ellipse is readily drawn.

To draw the joints normal to the intrados we must first draw tangents at the points just determined. Draw a tangent

bh in No. 1 and project it on the groin as BH ; draw HK parallel to the axis of No. 2, and join k and c for the new tangent. The normal is, of course, drawn perpendicular to this tangent, and the point m fixed by laying off its height above the springing-plane, as shown by l in No. 1. The reason for this construction will be evident if the student remember that the tangent to the intersection of two surfaces lies in the intersection of the tangent planes.

PRS shows the groin revolved into H , about POS as an axis.

Joining the points LMO , etc., gives the groin of the extrados.

43. Exercises.—1. Isometric and patterns of keystone and a springing-stone.

2. Two vaults of unequal spans uniting at an angle of 60° .

3. Details for 2.

4. Let vault No. 1 stop on the line $S-3$ and No. 2 on the line $P-3$.

ART. 5.—ARCH-CULVERTS.

PLATE VII.—6-FT. ARCH-CULVERT, AUBURN & ITHACA
R. R.

44. Complete working drawings are shown on this plate of a small culvert built of rough masonry.

45. Third-class masonry, as used on this road, is specified as being rubble-work (§ 12), laid with mortar in irregular courses, and will consist of stone containing generally six cubic feet each, so disposed as to make a firm and compact work; and no stone in the work shall contain less than three cubic feet, except for filling up the interstices between the large blocks in the heart of the wall. At least one fifth of the face shall be composed of headers extending full size four feet into the wall, and from the back the same proportion and of the same dimensions, so arranged that a header in the back shall be between two headers in the face. The corner-stones shall be neatly hammer-dressed, so as to have horizontal beds and vertical joints. Also, drafts to be cut on all covers of masonry.

46. The stones for the faces of the arch, coping, etc., are fully figured, and the mason is therefore able to cut them without further detailed drawings.

The method adopted on this plate of showing one half views is done only to economize space. It is not recommended for working drawings of this class. The little extra time required to make the complete drawing is more than

balanced by the time saved during construction in avoiding numberless questions and the probability of making corrections on work done.

This drawing is so well figured and lettered throughout that the student needs only to study it carefully in order to fully understand it.

PLATE 8
12 FOOT ARCH
 ON THE
 AUBURN & ITHACA R. R.

SCALE OF FEET
 0 2 4 6

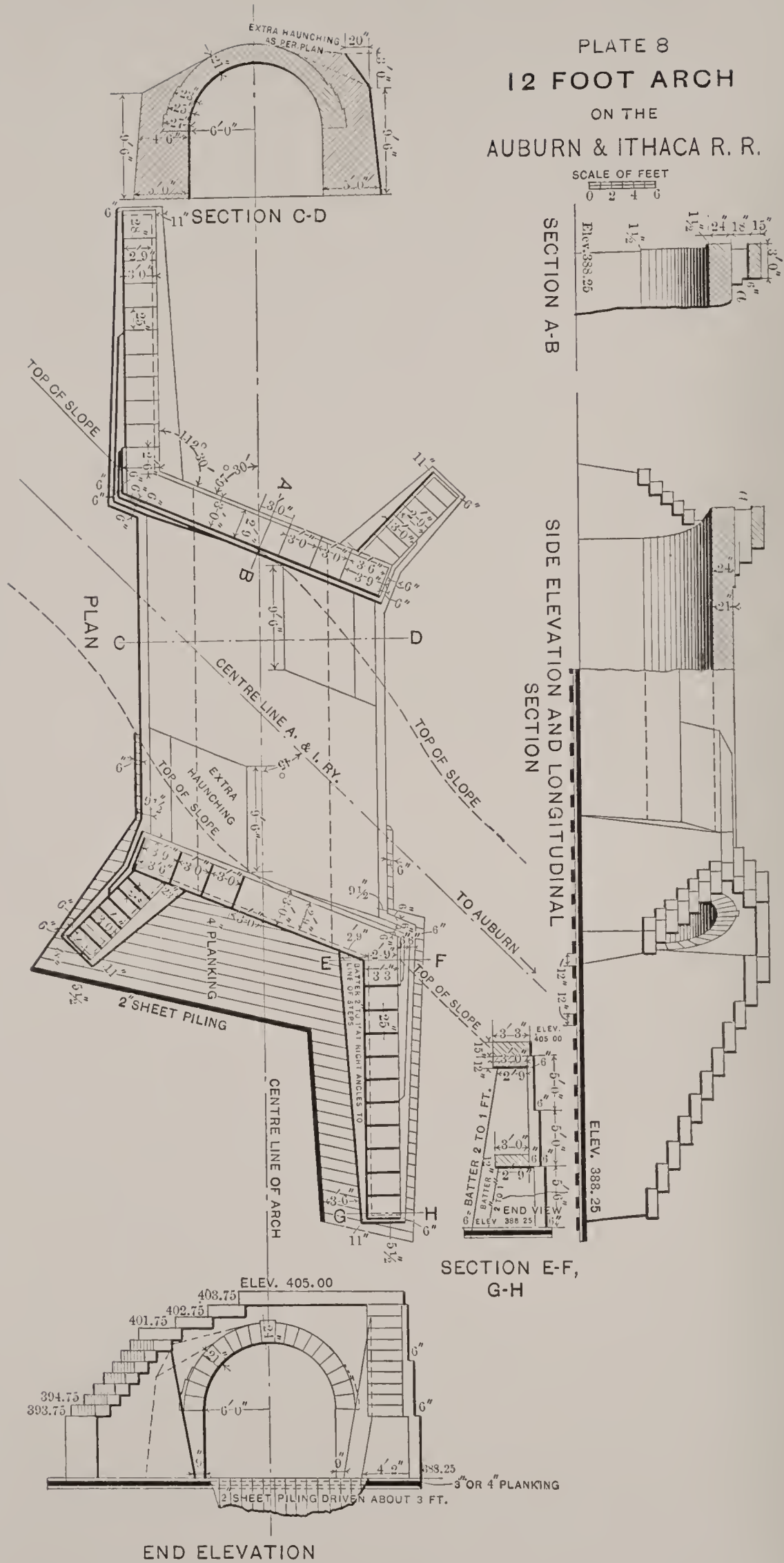

PLATE VIII.—12-FT. ARCH ON THE AUBURN & ITHACA R. R.

47. This is a good illustration of a case where the railroad does not cross the stream at right angles. To save building a larger structure than necessary recourse is had to a skew-face arch, i.e., one in which the axis is oblique to the plane of the faces. Fig. 28 illustrates this, the dotted lines showing where the faces of a plain right arch giving the same width of roadway as the skew-face arch would come.

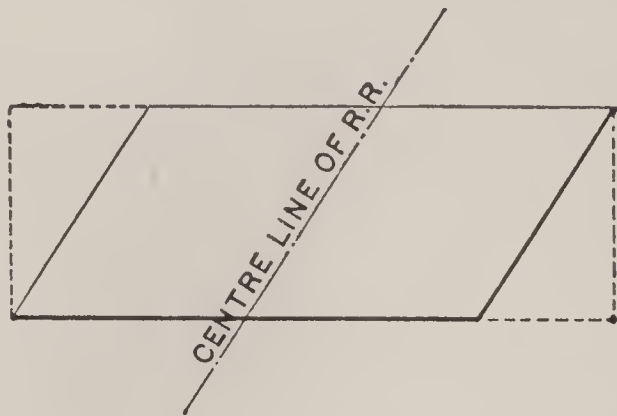

FIG. 28.

The extra haunching shown on the various figures is to strengthen the arch, and the planking, held by heavy sheet piling at the ends, serves to prevent the stream from scouring under the arch. The wing-walls are built with an even batter on the inside faces, while for the outside faces and back of the parapet-walls the same effect is obtained by building steps. This is plainly shown on the right wing-wall of the end elevation.

The right section CD shows the dimensions of the abutment-walls and the increased depth of the sheeting towards the springing.

The student should note that, although the end elevation shows the arch as a semicircle, it is really a semiellipse with diameters equal to 13 feet and 12 feet respectively.

Stones such as α on section AB and on longitudinal

section and in other places are not filled in with cross-section lines, because it is desired to bring the cut-stone work into prominence. The general arrangement of the drawings on this plate is very good, the draughtsman being enabled to readily project from plan to elevation, sections, etc.

48. In passing it may be well to note the difference existing between the term plan as used by the engineer and by the architect. The first uses it in the strictly correct sense, i.e., horizontal projection, while with the second it generally means a horizontal section at some point; thus the plan on this plate would be an architect's top view.

PLATE 9
 DETAILS OF 12 FOOT ARCH
 ON THE
 AUBURN & ITHACA R. R.

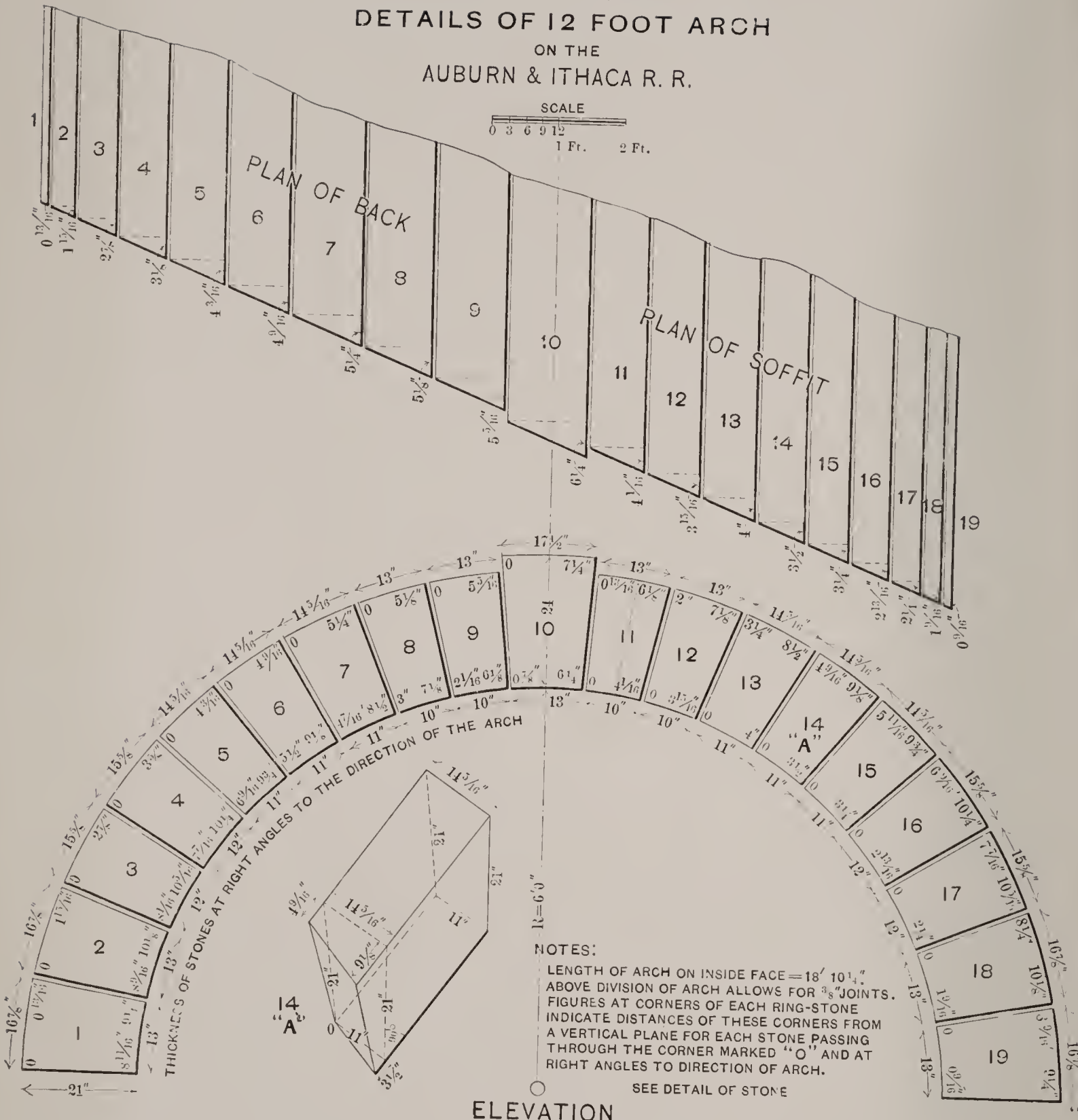
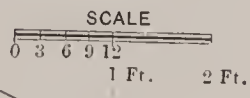

NOTES:
 LENGTH OF ARCH ON INSIDE FACE = 18' 10 1/4"
 ABOVE DIVISION OF ARCH ALLOWS FOR 3/8" JOINTS.
 FIGURES AT CORNERS OF EACH RING-STONE
 INDICATE DISTANCES OF THESE CORNERS
 FROM A VERTICAL PLANE FOR EACH STONE
 PASSING THROUGH THE CORNER MARKED "O"
 AND AT RIGHT ANGLES TO DIRECTION OF ARCH.

SEE DETAIL OF STONE

ELEVATION

PLATE IX.—DETAILS OF ARCH ON PLATE VIII.

49. Here are shown in a complete and simple manner the necessary details for the face-voussoirs of the skew-face arch on Plate VIII. The face is projected on a vertical plane at right angles to the axis of the arch, thus showing a semi-circle instead of a semiellipse. The $18' 10\frac{1}{4}''$ given in the notes as the length of arch on inside face is the length of the intrados of a right section. As the thicknesses of the arch-stones are measured in this plane, it is evident that if proper measurements are given from such a plane to the outside corners of each face-stone the face of the arch will have the desired skew. These distances may be readily obtained from the complete plan of soffit and back. The plan as given shows the method, and for the sake of clearness the soffit and back are shown separate. Fig. 29 shows both projected on the same figure.

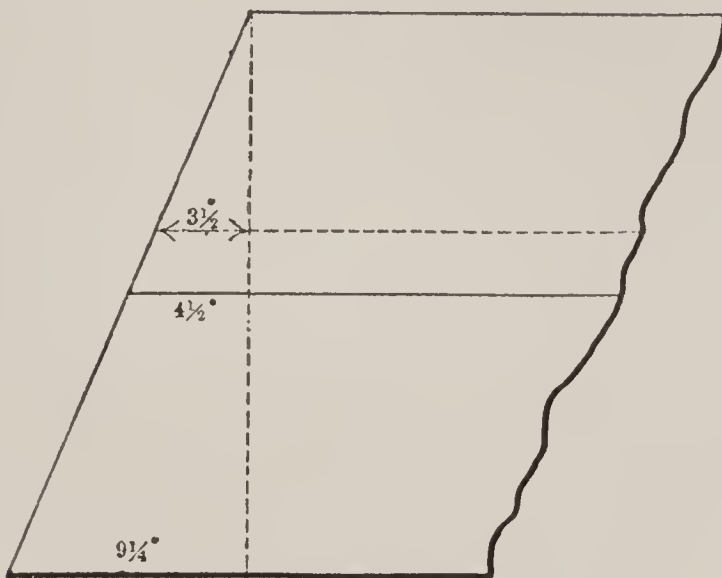

FIG. 29.

The dimensions given on the drawings, together with the specifications for the kinds of masonry of which the structure is to be built, will enable the mason to shape the stones properly.

Masonry for arch-culverts is sometimes divided into first and second class, but a general specification is as follows:

50. Arch-culvert Masonry.—The abutments are to be built of second-class masonry (§ 54).

The beds and joints of the arch-stone are to be accurately cut, and to be laid in courses throughout. The ring-stone will be neatly cut, and composed of alternate long and short bond-stones of not less than three feet and eighteen inches respectively. The parapet and wing walls will be built similarly to the abutments, and surmounted with a well-dressed coping, not less than fourteen inches thick and three feet wide, to be paid for at the same rate as for arch-culvert masonry. The outside stones to be laid in cement mortar, and the whole wall to be thoroughly grouted, each course separately. The spandrel-backing (haunching) to be good rubble-work, laid in mortar, built as directed by the engineer, and to be paid for at the same rate as third-class bridge masonry.

In any arch-culvert or bridge the abutments, wing and spandrel walls, and backing, or any of these, may, at the discretion of the engineer, be built of rubble-work, similar to that of third-class bridge masonry (§ 42), and when so built shall be paid for at the same price as that class of masonry.

51. Exercises on Plates VIII and IX.—1. Make an end elevation taken at right angles to the plane of the face of the arch.

2. Draw isometrics of, and patterns for, some of the coping-stones of the wing and parapet walls.

3. Check the corner dimensions given for the keystone on Plate IX, and make an isometric drawing of the stone.

PLATE 10
SOUTH ABUTMENT & PIER

JORDAN CREEK BRIDGE
 LEHIGH VALLEY R. R.

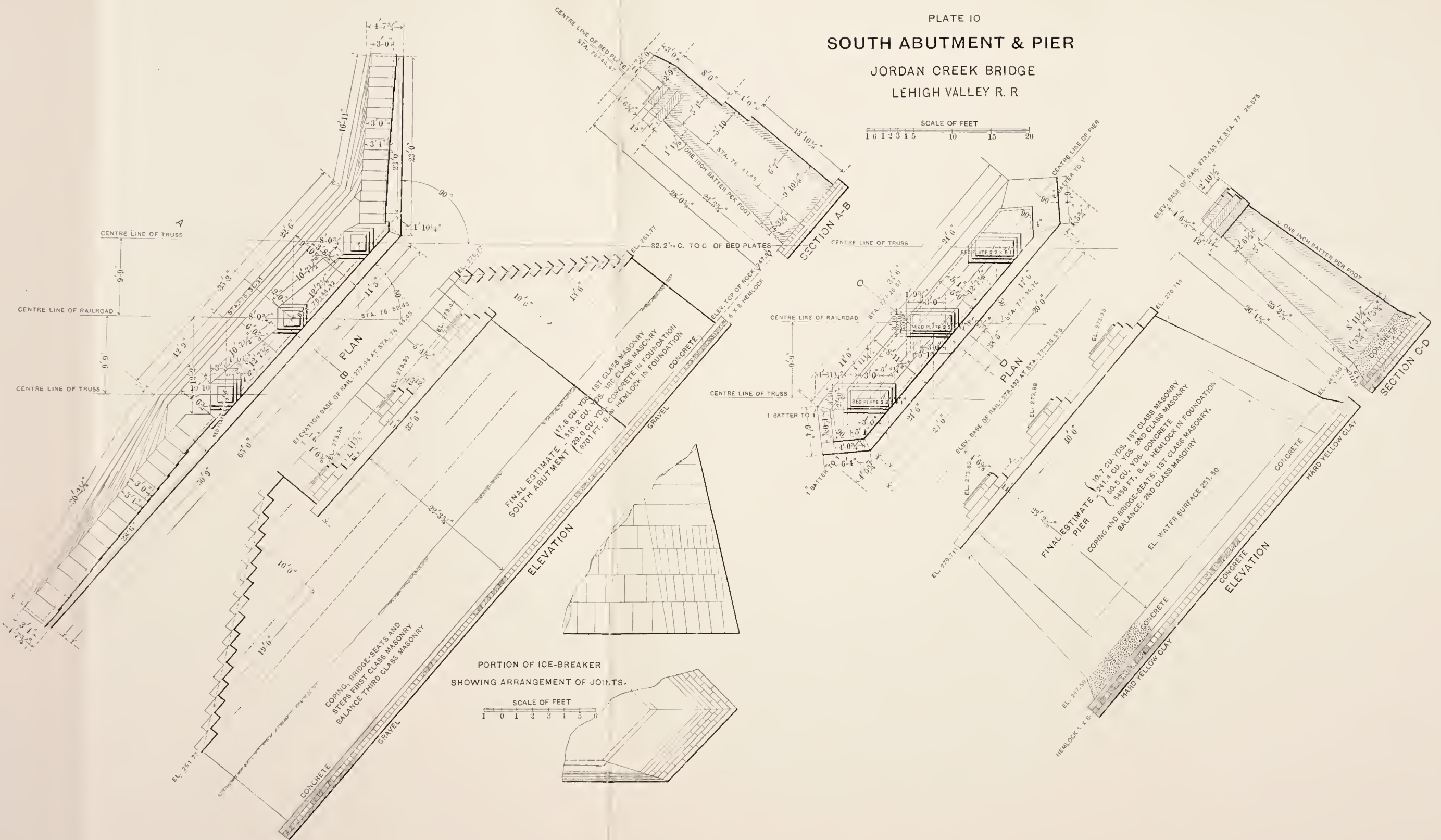
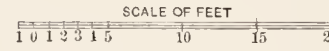

PORTION OF ICE-BREAKER
 SHOWING ARRANGEMENT OF JOINTS.

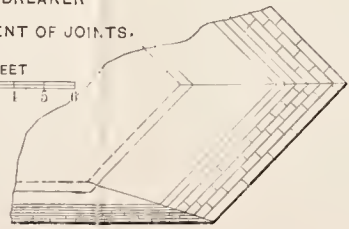
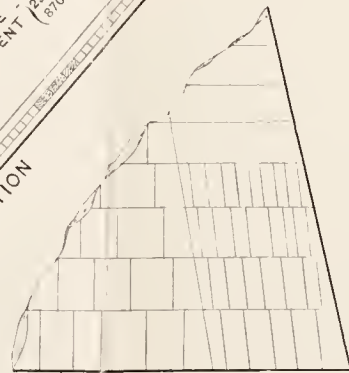
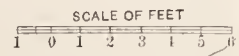

ART. 6.—RAILROAD-BRIDGE MASONRY.

PLATE X.—ABUTMENT AND PIER ON LEHIGH VALLEY RAILROAD.

52. The drawings for this piece of work are much more finished in appearance than the actual structures. By comparison of this plate with No. 11 it will at once be seen that although a great many dimensions are given for the abutment and pier there are but very few dimension-stones and no details for any cut stone. A reference to the specifications for the kinds of masonry used (§§ 50, 53, and 54) shows plainly that no special details are needed. The original drawings are unusually well figured, but for the purpose of reproduction it was found necessary to omit some. The student's attention is, however, called to the fact that it is always well to give full dimensions for a working drawing if it is expected to carry out the work in exact accordance with them. Scaled dimensions, especially from a blue print, are apt to be very misleading. A close study of working drawings and noting carefully the work being done on similar structures in the course of erection will now teach the draughtsman where dimensions are most needed and where he can save himself unnecessary work.

Here, as on Plate VIII, the faces of the different walls have an even batter, while the backs are stepped.

Notice how the steps on the wing-walls radiate from the steps on the back of the abutment. The sections *AB* and *CD* are taken on broken lines in order that the thickness of

all of the stones supporting the bed-plates may be shown on one section.

The ends of the pier are shaped as shown to turn aside driftwood, ice, etc., and to prevent the forming of eddies around the pier, which might scour at the foundation.

53. First-class Masonry will be first-class rock range-work (§ 14). The stone to be accurately squared, jointed, and bedded, and laid in courses not less than ten inches thick, nor exceeding twenty-four inches in thickness, regularly decreasing from bottom to top of pier or abutment. The stretchers shall in no case have less than sixteen inches bed for a ten-inch course, and for all courses above sixteen inches at least as much bed as face; they shall generally be at least four feet in length. The headers will be of similar size with the stretchers, and shall hold the size in the heart of the wall that they show on the face, and be so arranged as to occupy one fifth of the face of the wall, and they will be similarly disposed in the back. When the thickness of the wall necessitates it, stones not less than four feet in length will be placed transversely in the heart of the wall, to connect the two opposite sides of it. The stones for the heart of the wall need not be jointed, but must be well fitted to their places. The stones forming the points of piers which act as ice-breakers shall be neatly dressed on their faces; the other face-stones will, with the exception of the draft, be generally left with the face as they come from the quarry, unless the projections above the draft should exceed two inches, in which case they shall be roughly scabbled down to that point. The coping shall not be less than fourteen inches thick and three feet wide, well dressed and fastened together and to lower courses with clamps of iron, without extra charge.

54. Second-class Masonry.—This comes under squared-

stone masonry (§§ 6 and 13), though the facing is generally a better grade of work. Extracts from specifications for this class are given below.

It shall be range-work or in broken courses, as may best suit the stone that is used. Face-stones to be accurately jointed and bedded, and no stone to be less than eight inches thick. The stretchers in the face to have beds of at least fifteen inches, and in no case less bed than rise, and to be not less than three feet long, measured in the face of the wall. The headers shall not have less than sixteen inches length of face, and shall extend at least three and one half feet into the wall, and not less than one header to every seven feet of wall, measured from centre to centre, and so arranged that a header in a superior course shall be placed between two headers in the course below. Backing-stones to be of large size, have parallel beds, but beds not dressed, as in first-class masonry. The outside stone to be set in cement mortar. Drafts to be cut on all corners of masonry.*

* For complete specifications on all grades of railroad masonry see "A Treatise on Masonry Construction," by Prof. I. O. Baker.

ART. 7.—CANAL-LOCK MASONRY.

PLATE XI.—ST. MARY'S FALLS CANAL-LOCK.

55. The drawings and specifications for this large and important piece of masonry are very detailed and very precise. Outside of government work such exhaustive drawings would hardly be furnished for similar construction.

Extracts from the specifications for the cut stone say:

“The cut stone shall conform approximately in dimensions to the bill of materials appended to these specifications, but exact drawings of the stones will be furnished the contractor when he needs them.”

No joints were cut closer than $\frac{3}{8}$ inch, and it was specified that, “No joint shall vary in thickness from the dimensions specified, and the dimensions of all stones shall be such that the centre of each vertical joint shall not vary more than $\frac{1}{10}$ inch on either side of a vertical line through the centre of the lowest corresponding joint.”

Drawings were therefore made of every course of stone in the lock (and there were twenty-three such courses), elevations, sections and patterns, and other details, specimens of which are shown on Plate XI. The full-size patterns for every stone not rectangular were cut out of zinc and furnished the contractor by the United States engineers in charge.

56. There being a large number of such patterns (471), some system of identification was of course necessary, and each different pattern received a distinctive number. The numbering on the plan and the patterns corresponding are

ST. MARY'S FALLS CANAL, MICH.

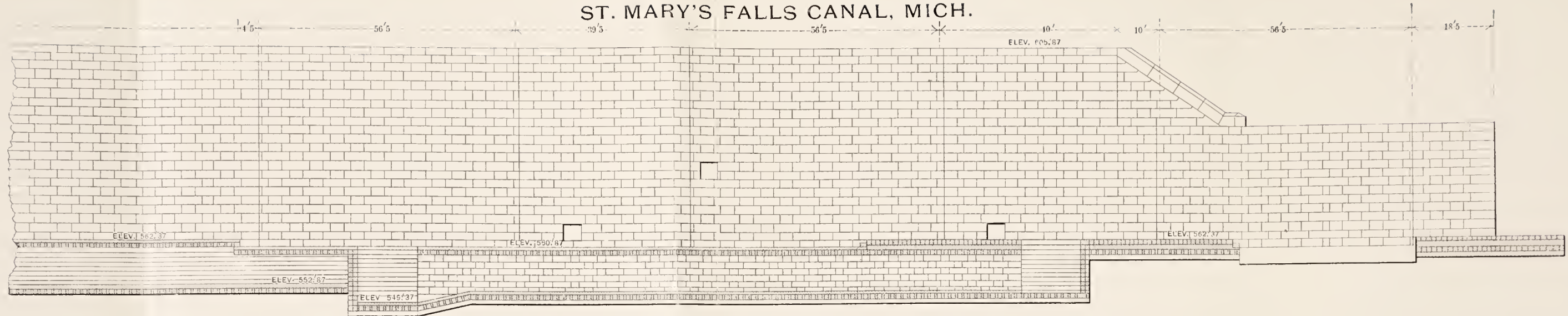

LONGITUDINAL SECTION OF FLOOR AND ELEVATION OF WALL AT EAST END

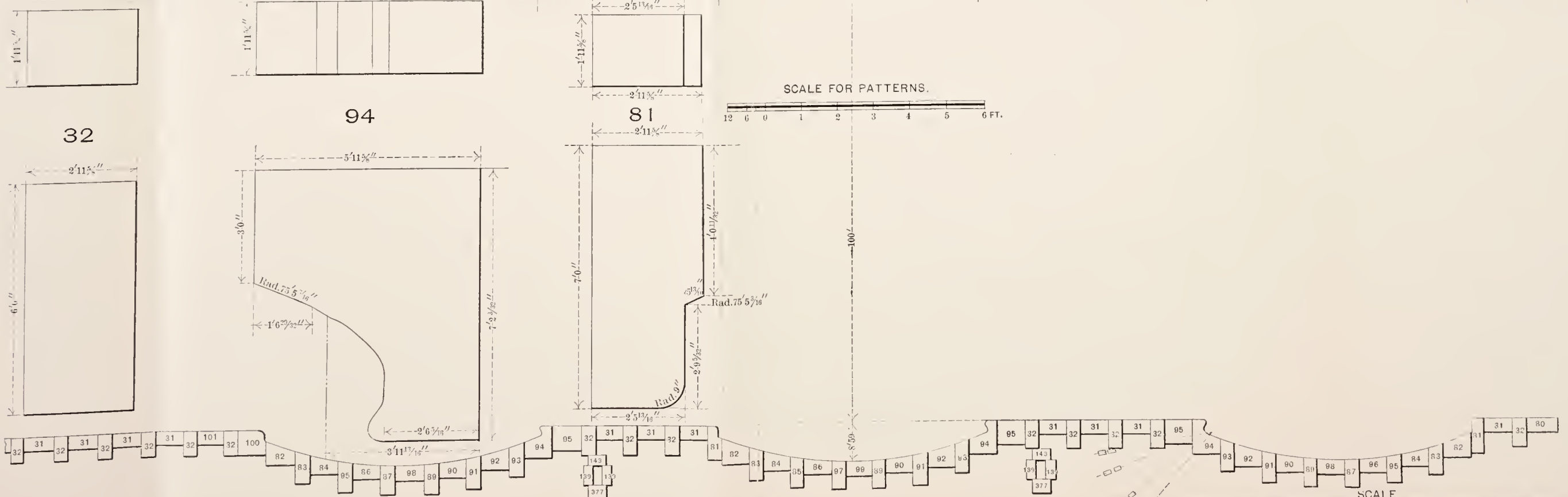
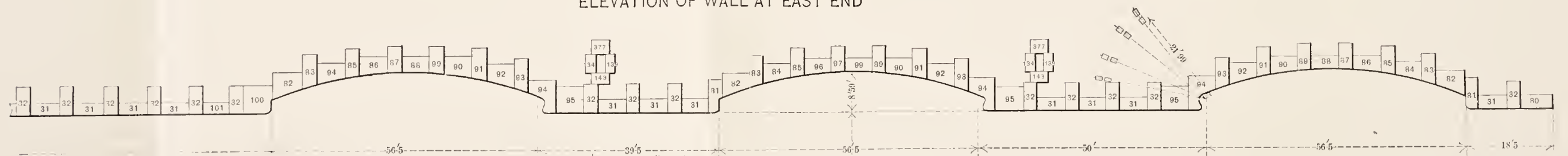

PLAN OF EAST END OF COURSE 7.

shown on this plate. An idea of the scheme followed for identifying the cut stone for a large building, as they are received from the stone-cutters, may be gained from Plates XII and XIII.

In the lock now under consideration the finished stone, when inspected by the United States inspector at the stone-yard, was marked with its proper pattern number, course number, and running number. The exact place on the wall for each stone of the successive courses as carried up was accurately marked for the contractor. The contractor, therefore, had only to cut the stone to certain patterns and put it on the place marked for it on the wall. There were over 1400 pieces of cut stone, aggregating nearly 19,000 cubic yards, and they all went together so nicely that it took less than ten hours' work for a stone-cutter to correct errors on the whole job.

57. The stones varied in size from $3\frac{1}{2}$ ft. \times 8 ft. \times $8\frac{1}{2}$ ft. to $\frac{2}{3}$ ft. \times $1\frac{1}{6}$ ft. \times 8 ft., giving 238 and 6 cu. ft. respectively. In general the dimensions were 2 ft. \times 3 ft. \times 6 ft. As the stone was specified to weigh not less than 148 lbs. to the cubic foot, the above dimensions give over 35,000 lbs. for the largest, and over 5000 lbs. for the average weight of each stone. These figures should give the student a good guide as to the dimensioning of cut stone, that they may be easily handled with the ordinary machinery.

It may be of interest to note that the cut-stone work in this structure was furnished and laid in the walls for \$28.50 per cu. yd., a reasonable figure for such work.

ART. 8.—ARCHITECTURAL STONEMWORK.

PLATE XII.—TOWER DOOR FROM THE BUILDING FOR
LIBRARY OF CONGRESS.

58. The drawings on this and the next two plates are further examples of carefully detailed work. All the face-stones in this immense building are dimension-stones, and details like those on Plate XI were necessary. In this case, however, the usual practice was followed; namely, that of furnishing the contractor for the stonework with the dimensioned drawings instead of the patterns, and letting him make the latter himself. The inspected stone was properly marked for ready identification, shipped to the site of the building, and at once deposited near its final place.

59. Plate XII is a recessed entrance in a circular wall. The clear opening, being less than four feet, is readily spanned by a single stone and the construction of an arch as in Plate V avoided.

60. **Exercises.**—1. Draw a horizontal section through the course *G*.

2. Draw isometrics of the stones *d*, *b*, and *c*.

3. Draw the necessary patterns for *d*, *b*, and *c*.

4. Draw an isometric of, and the necessary patterns for, one of the stones in the doorway, in course *E*.

PLATE 12
 TOWER DOOR
 FROM THE
 LIBRARY OF CONGRESS

SCALE
 0 1 Ft.

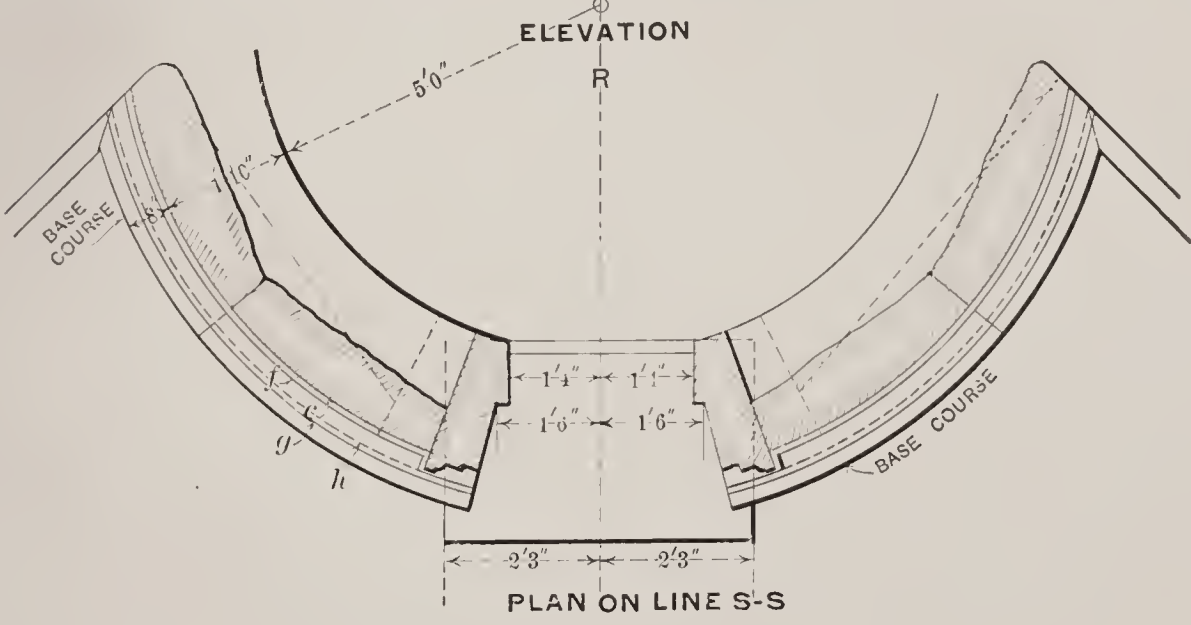
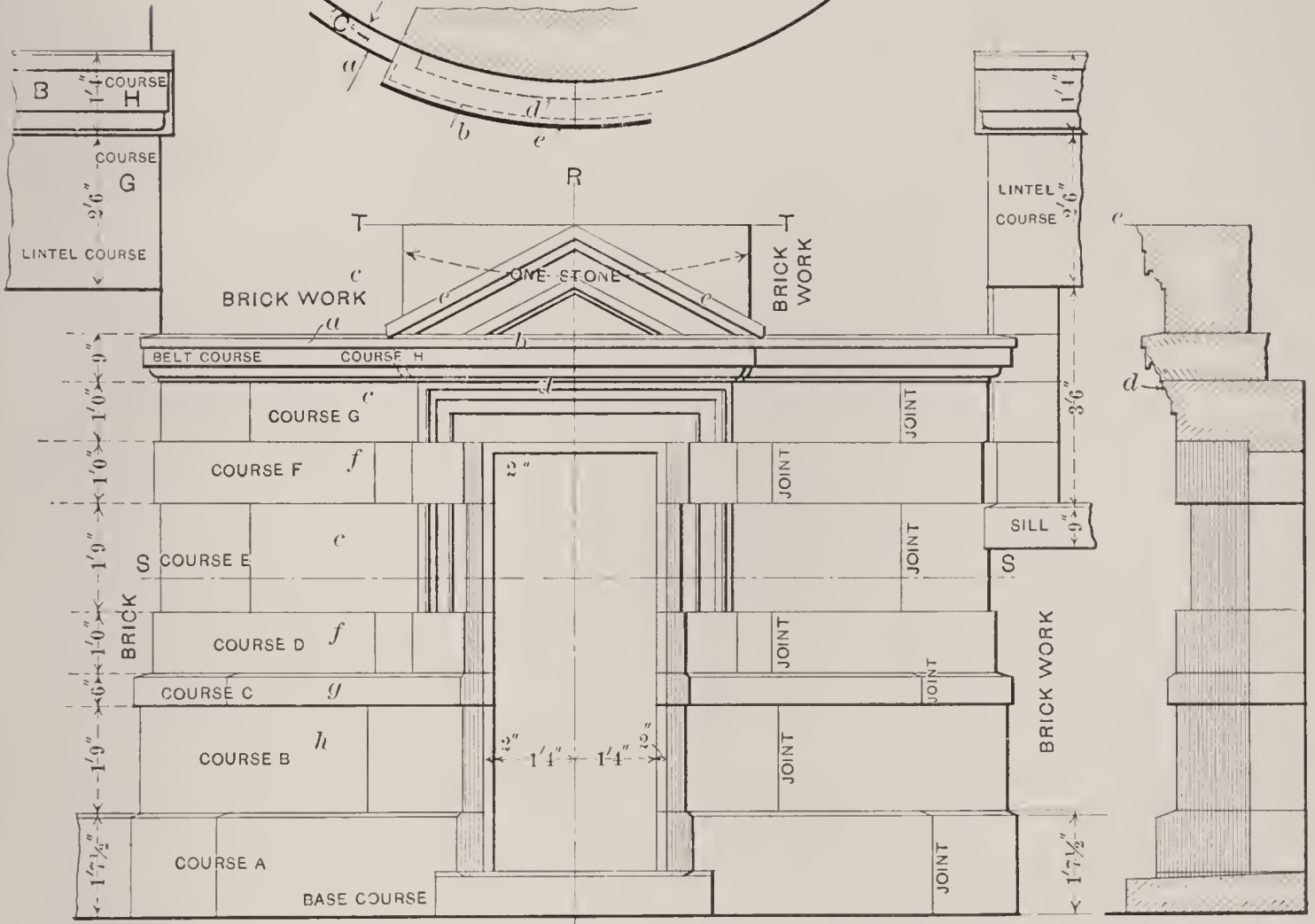
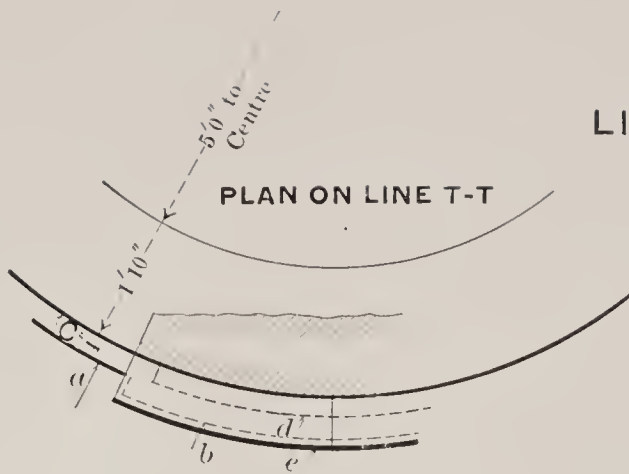
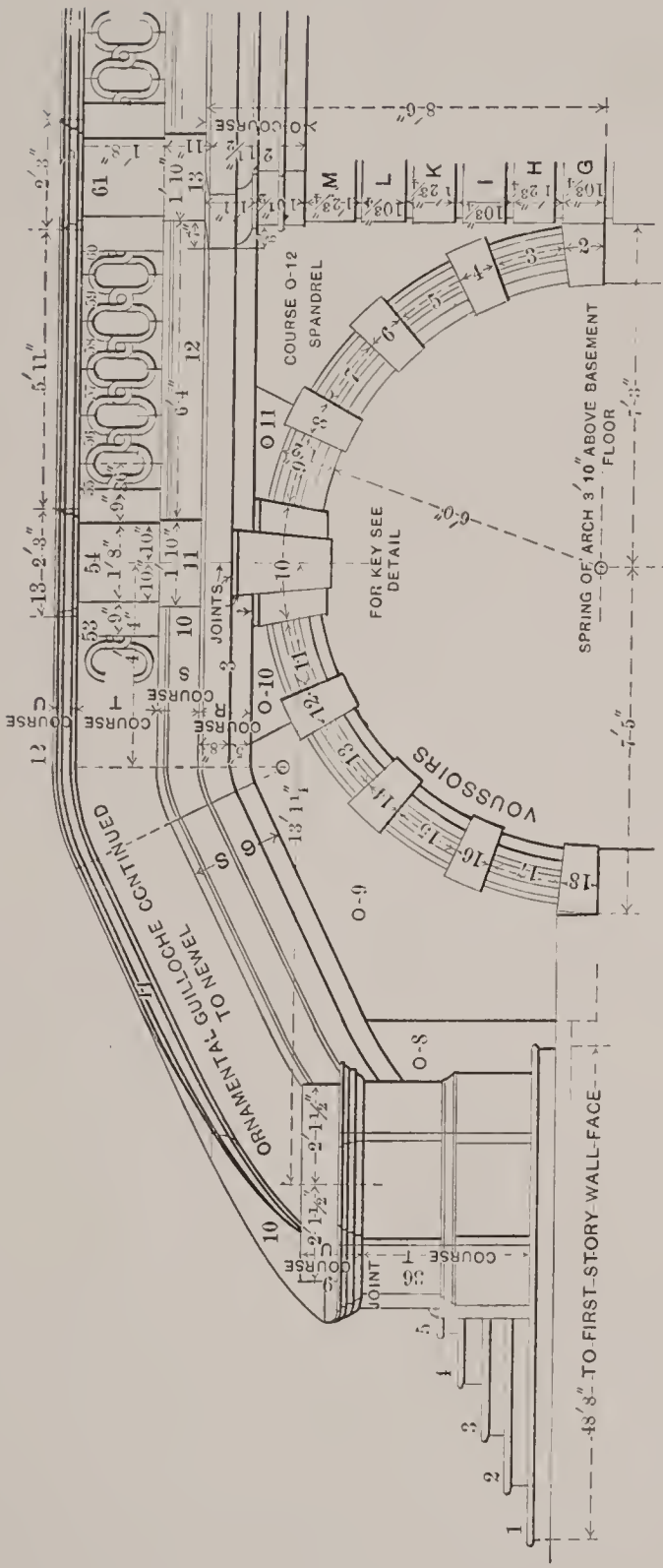

PLATE 13
ENTRANCE & PORTE COCHÉRE
 FROM THE
 LIBRARY OF CONGRESS

SCALE OF FEET
 0 1



ELEVATION

NOTE: FIGURES FOR STEPS & PLATFORMS TAKEN TO FACES OF RISERS AND PLATFORMS, NOT TO NOSING

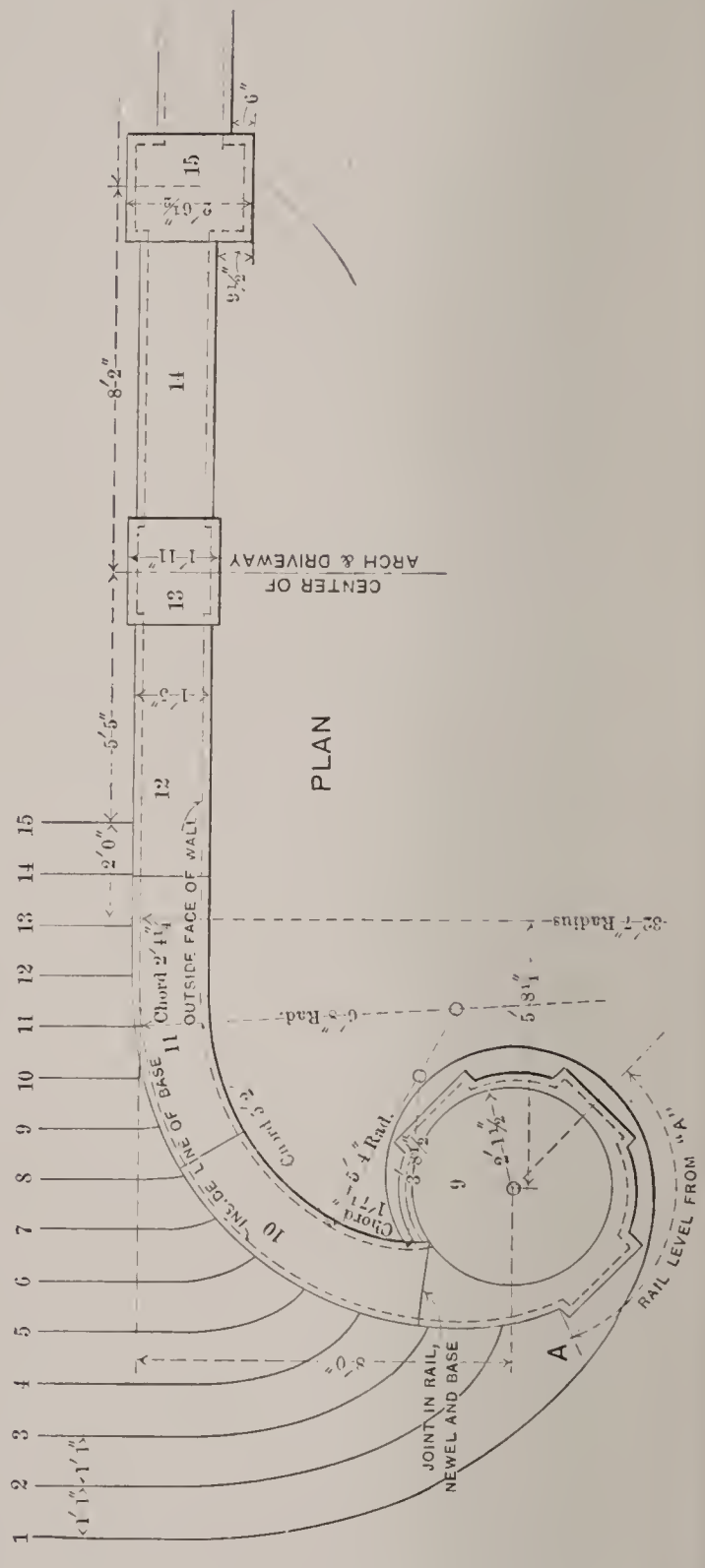

PLAN

PLATES XIII AND XIV.—ENTRANCE AND PORTE COCHÈRE
FROM BUILDING FOR LIBRARY OF CONGRESS.

61. These drawings show a complex and elegant piece of architectural masonry. It is impossible in this limited space to give all the necessary detail drawings, but a sufficient number are given to show the student what else would be required. Every joint of the stones is carefully shown, so that the full-size patterns can easily be made, and the dimensions extending into the walls are given by numerous sections. Some of those not shown are horizontal sections of the courses marked *R*, *S*, *T*, and *U* on the elevation, and vertical sections at different points along the railing, etc.

62. The development of the railing is obtained very simply, thus: From the point *A* on the plan as an origin the length of tread No. 1 as measured on the outer curve of the rail is laid off in the development; 2, 3, 4, etc., are similarly laid off, and the vertical distances of the railing above the plane of each step as obtained from the elevation marked on the corresponding places of the development. The pattern of each stone of the railing is now easily obtained by bending the developed pieces to the proper curves shown on the plan. The faces are of course left rough, so that the cutter who does the artistic work may draw and cut the ornaments.

63. **Exercises.**—1. Make details, isometric and patterns, for one of the railing-posts.

2. How would the stone-cutter work the skew part of the top of the railing?

PLATE 14
 ENTRANCE & PORTE COCHERE
 FROM THE
 LIBRARY OF CONGRESS

SCALE OF FEET
 0 1

ELEVATION OF ENTRANCE STEPS

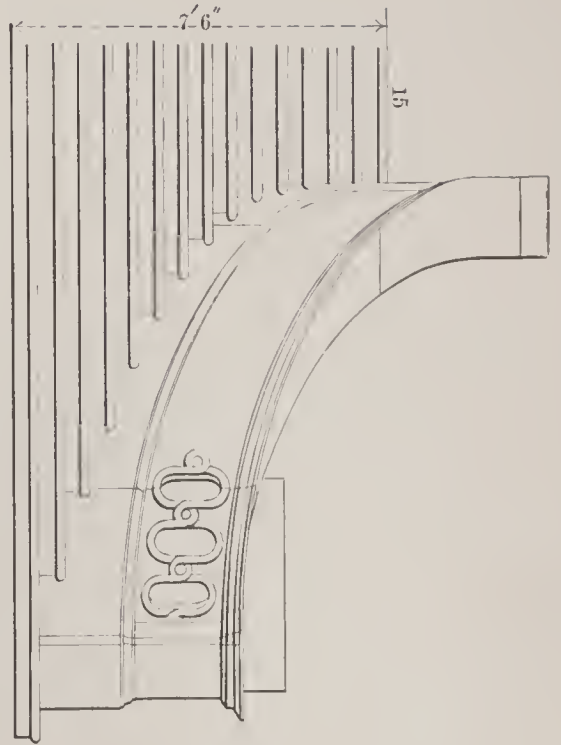

DEVELOPMENT OF RAILING

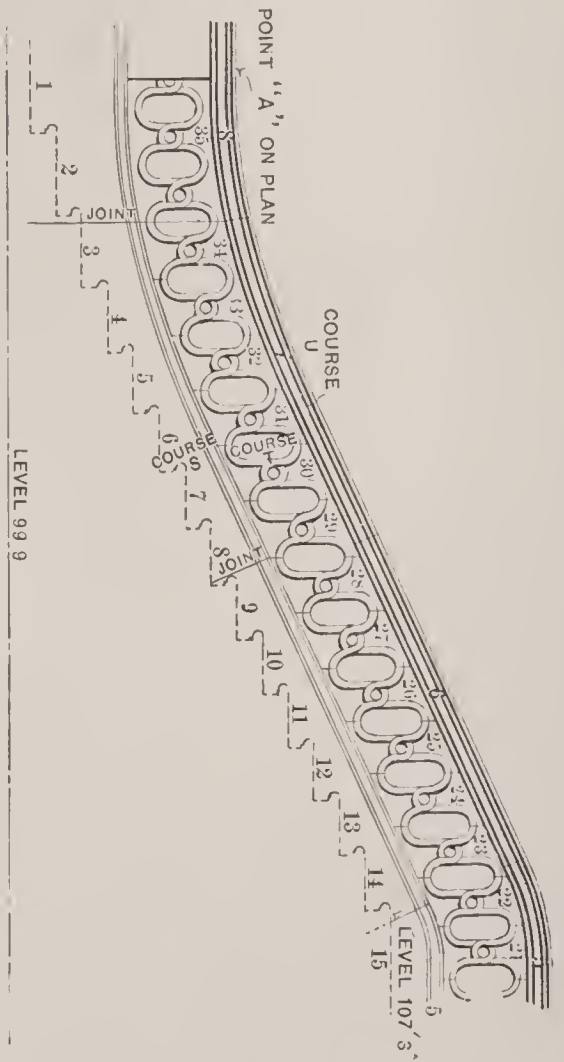

LONGITUDINAL SECTION

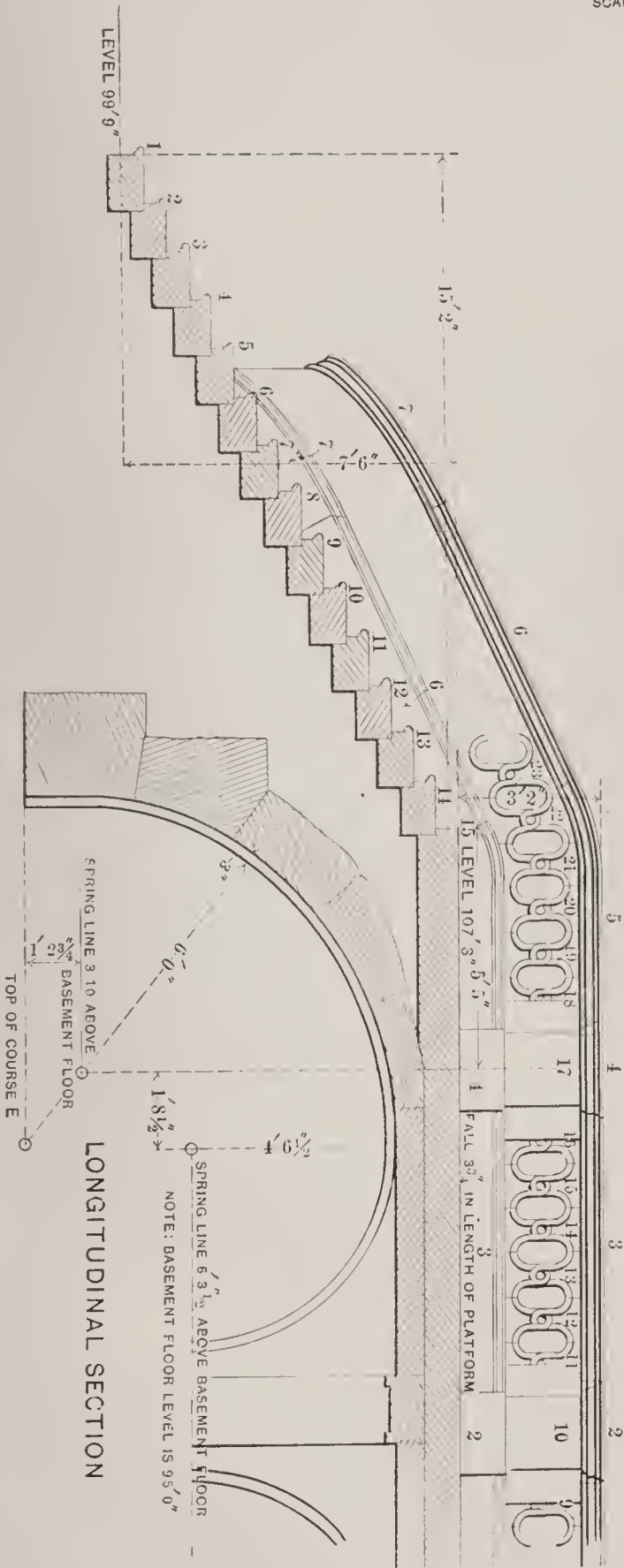

SHORT-TITLE CATALOGUE

OF THE

PUBLICATIONS

OF

JOHN WILEY & SONS,

NEW YORK.

LONDON: CHAPMAN & HALL, LIMITED.

ARRANGED UNDER SUBJECTS.

Descriptive circulars sent on application. Books marked with an asterisk are sold at *net* prices only, a double asterisk (**) books sold under the rules of the American Publishers' Association at *net* prices subject to an extra charge for postage. All books are bound in cloth unless otherwise stated.

AGRICULTURE.

Armsby's Manual of Cattle-feeding.....	12mo,	\$1 75
Principles of Animal Nutrition.....	8vo,	4 00
Budd and Hansen's American Horticultural Manual:		
Part I.—Propagation, Culture, and Improvement.....	12mo,	1 50
Part II.—Systematic Pomology.....	12mo,	1 50
Downing's Fruits and Fruit-trees of America.....	8vo,	5 00
Elliott's Engineering for Land Drainage.....	12mo,	1 50
Practical Farm Drainage.....	12mo,	1 0
Green's Principles of American Forestry. (<i>Shortly.</i>)		
Grotenfelt's Principles of Modern Dairy Practice. (Woll.).....	12mo,	2 0
Kemp's Landscape Gardening.....	12mo,	2 50
Maynard's Landscape Gardening as Applied to Home Decoration.....	12mo,	1 5
Sanderson's Insects Injurious to Staple Crops.....	12mo,	1 5
Insects Injurious to Garden Crops. (<i>In preparation.</i>)		
Insects Injuring Fruits. (<i>In preparation.</i>)		
Stockbridge's Rocks and Soils.....	8vo,	2
Woll's Handbook for Farmers and Dairymen.....	16mo,	1 50

ARCHITECTURE.

Baldwin's Steam Heating for Buildings.....	12mo,	2 50
Berg's Buildings and Structures of American Railroads.....	4to,	5 00
Birkmire's Planning and Construction of American Theatres.....	8vo,	3 00
Architectural Iron and Steel.....	8vo,	3 50
Compound Riveted Girders as Applied in Buildings.....	8vo,	2 00
Planning and Construction of High Office Buildings.....	8vo,	3 50
Skeleton Construction in Buildings.....	8vo,	3 00
Briggs's Modern American School Buildings.....	8vo,	4 00
Carpenter's Heating and Ventilating of Buildings.....	8vo,	4 00
Freitag's Architectural Engineering. 2d Edition, Rewritten.....	8vo,	3 50
Fireproofing of Steel Buildings.....	8vo,	2 50
French and Ives's Stereotomy.....	8vo,	2 50
Gerhard's Guide to Sanitary House-inspection.....	16mo,	1 00
Theatre Fires and Panics.....	12mo,	1 50

Hatfield's American House Carpenter.....	8vo,	5 00
Holly's Carpenters' and Joiners' Handbook.....	18mo,	75
Johnson's Statics by Algebraic and Graphic Methods.....	8vo,	2 00
Kidder's Architect's and Builder's Pocket-book.....	16mo, morocco,	4 00
Merrill's Stones for Building and Decoration.....	8vo,	5 00
Monckton's Stair-building.....	4to,	4 00
Patton's Practical Treatise on Foundations.....	8vo,	5 00
Siebert and Biggin's Modern Stone-cutting and Masonry.....	8vo,	1 50
Snow's Principal Species of Wood.....	8vo,	3 50
Sondericker's Graphic Statics with Applications to Trusses, Beams, and Arches. (Shortly.)		
Wait's Engineering and Architectural Jurisprudence.....	8vo,	6 00
	Sheep,	6 50
Law of Operations Preliminary to Construction in Engineering and Architecture.....	8vo,	5 00
	Sheep,	5 50
Law of Contracts.....	8vo,	3 00
Woodbury's Fire Protection of Mills.....	8vo,	2 50
Worcester and Atkinson's Small Hospitals, Establishment and Maintenance, Suggestions for Hospital Architecture, with Plans for a Small Hospital.		
	12mo,	1 25
The World's Columbian Exposition of 1893.....	Large 4to,	1 00

ARMY AND NAVY.

Bernadou's Smokeless Powder, Nitro-cellulose, and the Theory of the Cellulose Molecule.....	12mo,	2 50
* Bruff's Text-book Ordnance and Gunnery.....	8vo,	6 00
Chase's Screw Propellers and Marine Propulsion.....	8vo,	3 00
Craig's Azimuth.....	4to,	3 50
Crehore and Squire's Polarizing Photo-chronograph.....	8vo,	3 00
Cronkhite's Gunnery for Non-commissioned Officers.....	24mo, morocco,	2 00
* Davis's Elements of Law.....	8vo,	2 50
* Treatise on the Military Law of United States.....	8vo,	7 00
*	Sheep	7 50
De Brack's Cavalry Outpost Duties. (Carr.).....	24mo, morocco,	2 00
Dietz's Soldier's First Aid Handbook.....	16mo, morocco,	1 25
* Dredge's Modern French Artillery.....	4to, half morocco,	15 00
Durand's Resistance and Propulsion of Ships.....	8vo,	5 00
* Dyer's Handbook of Light Artillery.....	12mo,	3 00
Eissler's Modern High Explosives.....	8vo,	4 00
* Fieberger's Text-book on Field Fortification.....	Small 8vo,	2 00
Hamilton's The Gunner's Catechism.....	18mo,	1 00
* Hoff's Elementary Naval Tactics.....	8vo,	1 50
Ingalls's Handbook of Problems in Direct Fire.....	8vo,	4 00
* Ballistic Tables.....	8vo,	1 50
* Lyons's Treatise on Electromagnetic Phenomena. Vols. I. and II. 8vo, each,		6 00
* Mahan's Permanent Fortifications. (Mercur.).....	8vo, half morocco,	7 50
Manual for Courts-martial.....	16mo morocco,	1 50
* Mercur's Attack of Fortified Places.....	12mo,	2 00
* Elements of the Art of War.....	8vo,	4 00
Metcalf's Cost of Manufactures—And the Administration of Workshops, Public and Private.....	8vo,	5 00
* Ordnance and Gunnery.....	12mo,	5 00
Murray's Infantry Drill Regulations.....	18mo, paper,	10
* Phelps's Practical Marine Surveying.....	8vo,	2 50
Powell's Army Officer's Examiner.....	12mo,	4 00
Sharpe's Art of Subsisting Armies in War.....	18mo, morocco,	1 50

* Walke's Lectures on Explosives.....	8vo,	4 00
* Wheeler's Siege Operations and Military Mining.....	8vo,	2 00
Winthrop's Abridgment of Military Law.....	12mo,	2 50
Woodhull's Notes on Military Hygiene.....	16mo,	1 50
Young's Simple Elements of Navigation.....	16mo, morocco,	1 00
Second Edition, Enlarged and Revised.....	16mo, morocco	2 00

ASSAYING.

Fletcher's Practical Instructions in Quantitative Assaying with the Blowpipe.....	12mo, morocco,	1 50
Furman's Manual of Practical Assaying.....	8vo,	3 00
Miller's Manual of Assaying.....	12mo,	1 00
O'Driscoll's Notes on the Treatment of Gold Ores.....	8vo,	2 00
Ricketts and Miller's Notes on Assaying.....	8vo,	3 00
Ulke's Modern Electrolytic Copper Refining.....	8vo,	3 00
Wilson's Cyanide Processes.....	12mo,	1 50
Chlorination Process.....	12mo.	1 50

ASTRONOMY.

Comstock's Field Astronomy for Engineers.....	8vo,	2 50
raig's Azimuth.....	4to,	3 50
Doolittle's Treatise on Practical Astronomy.....	8vo,	4 00
Gore's Elements of Geodesy.....	8vo,	2 50
Hayford's Text-book of Geodetic Astronomy.....	8vo,	3 00
Merriman's Elements of Precise Surveying and Geodesy.....	8vo,	2 50
* Michie and Harlow's Practical Astronomy.....	8vo,	3 00
* White's Elements of Theoretical and Descriptive Astronomy.....	12mo,	2 00

BOTANY.

Davenport's Statistical Methods, with Special Reference to Biological Variation.....	16mo, morocco,	1 25
Thomé and Bennett's Structural and Physiological Botany.....	16mo,	2 25
Westermaier's Compendium of General Botany. (Schnejder.).....	8vo,	2 00

CHEMISTRY.

Adriance's Laboratory Calculations and Specific Gravity Tables.....	12mo,	1 25
Allen's Tables for Iron Analysis.....	8vo,	3 00
Arnold's Compendium of Chemistry. (Mandel.) (<i>In preparation.</i>)		
Austen's Notes for Chemical Students.....	12mo,	1 50
Bernadou's Smokeless Powder.—Nitro-cellulose, and Theory of the Cellulose Molecule.....	12mo,	2 50
Bolton's Quantitative Analysis.....	8vo,	1 50
* Browning's Introduction to the Rarer Elements.....	8vo,	1 50
Brush and Penfield's Manual of Determinative Mineralogy.....	8vo,	4 00
Classen's Quantitative Chemical Analysis by Electrolysis. (Boltwood.)...	8vo	3 00
Cohn's Indicators and Test-papers.....	12mo,	2 00
Tests and Reagents.....	8vo,	3 00
Copeland's Manual of Bacteriology. (<i>In preparation.</i>)		
Craft's Short Course in Qualitative Chemical Analysis. (Schaeffer.)....	12mo,	2 00
Drechsel's Chemical Reactions. (Merrill.).....	12mo,	1 25
Duhem's Thermodynamics and Chemistry. (Burgess.) (<i>Shortly.</i>)		
Eissler's Modern High Explosives.....	8vo,	4 00

Effront's Enzymes and their Applications. (Prescott.)	8vo,	3 00
Erdmann's Introduction to Chemical Preparations. (Dunlap.)	12mo,	1 25
Fletcher's Practical Instructions in Quantitative Assaying with the Blowpipe.		
	12mo, morocco,	1 50
Fowler's Sewage Works Analyses.	12mo,	2 00
Fresenius's Manual of Qualitative Chemical Analysis. (Wells.)	8vo,	5 00
Manual of Qualitative Chemical Analysis. Part I. Descriptive. (Wells.)	8vo,	3 00
System of Instruction in Quantitative Chemical Analysis. (Cohn.)		
2 vols. (<i>Shortly.</i>)		
Fuertes's Water and Public Health.	12mo,	1 50
Furman's Manual of Practical Assaying.	8vo,	3 00
Gill's Gas and Fuel Analysis for Engineers.	12mo,	1 25
Grotenfelt's Principles of Modern Dairy Practice. (Woll.)	12mo,	2 00
Hammarsten's Text-book of Physiological Chemistry. (Mandel.)	8vo,	4 00
Helm's Principles of Mathematical Chemistry. (Morgan.)	12mo.	1 50
Hinds's Inorganic Chemistry.	8vo,	3 00
* Laboratory Manual for Students	12mo,	75
Holleman's Text-book of Inorganic Chemistry. (Cooper.)	8vo,	2 50
Text-book of Organic Chemistry. (Walker and Mott.)	8vo,	2 50
Hopkins's Oil-chemists' Handbook.	8vo,	3 00
Jackson's Directions for Laboratory Work in Physiological Chemistry.	8vo,	1 00
Keep's Cast Iron.	8vo,	2 50
Ladd's Manual of Quantitative Chemical Analysis.	12mo.	1 00
Landauer's Spectrum Analysis. (Tingle.)	8vo,	3 00
Lassar-Cohn's Practical Urinary Analysis. (Lorenz.)	12mo,	1 00
Leach's The Inspection and Analysis of Food with Special Reference to State Control. (<i>In preparation.</i>)		
Löb's Electrolysis and Electrosynthesis of Organic Compounds. (Lorenz.)	12mo,	1 00
Mandel's Handbook for Bio-chemical Laboratory.	12mo,	1 50
Mason's Water-supply. (Considered Principally from a Sanitary Standpoint.)		
3d Edition, Rewritten.	8vo,	4 00
Examination of Water. (Chemical and Bacteriological.)	12mo,	1 25
Meyer's Determination of Radicles in Carbon Compounds. (Tingle.)	12mo,	1 00
Miller's Manual of Assaying.	12mo,	1 00
Mixter's Elementary Text-book of Chemistry.	12mo,	1 50
Morgan's Outline of Theory of Solution and its Results.	12mo,	1 00
Elements of Physical Chemistry.	12mo.	2 00
Nichols's Water-supply. (Considered mainly from a Chemical and Sanitary Standpoint, 1883.)	8vo,	2 50
O'Brine's Laboratory Guide in Chemical Analysis.	8vo,	2 00
O'Driscoll's Notes on the Treatment of Gold Ores.	8vo,	2 00
Ost and Kolbeck's Text-book of Chemical Technology. (Lorenz—Bozart.)		
(<i>In preparation.</i>)		
* Penfield's Notes on Determinative Mineralogy and Record of Mineral Tests.	8vo, paper,	50
Pictet's The Alkaloids and their Chemical Constitution. (Biddle.) (<i>In preparation.</i>)		
Pinner's Introduction to Organic Chemistry. (Austen.)	12mo,	1 50
Poole's Calorific Power of Fuels.	8vo,	3 00
* Reisig's Guide to Piece-dyeing.	8vo,	25 00
Richards and Woodman's Air, Water, and Food from a Sanitary Standpoint.	8vo,	2 00
Richards's Cost of Living as Modified by Sanitary Science.	12mo,	1 00
Cost of Food a Study in Dieteries.	12mo,	1 00
* Richards and Williams's The Dietary Computer.	8vo,	1 50
Ricketts and Russell's Skeleton Notes upon Inorganic Chemistry. (Part I.—Non-metallic Elements.)	8vo, morocco,	75
Ricketts and Miller's Notes on Assaying.	8vo,	3 00

Deal's Sewage and the Bacterial Purification of Sewage.....	8vo,	3 50
Ruddiman's Incompatibilities in Prescriptions.....	8vo,	2 00
Schimpf's Text-book of Volumetric Analysis.....	12mo,	2 50
Spencer's Handbook for Chemists of Beet-sugar Houses.....	16mo, morocco,	3 00
Handbook for Sugar Manufacturers and their Chemists..	16mo, morocco,	2 00
Stockbridge's Rocks and Soils.....	8vo,	2 50
* Tillman's Elementary Lessons in Heat.....	8vo,	1 50
* Descriptive General Chemistry.....	8vo	3 00
Treadwell's Qualitative Analysis. (Hall.).....	8vo,	3 00
Turneaure and Russell's Public Water-supplies.....	8vo,	5 00
Van Deventer's Physical Chemistry for Beginners. (Boltwood.).....	12mo,	1 50
* Walke's Lectures on Explosives.....	8vo,	4 00
Wells's Laboratory Guide in Qualitative Chemical Analysis.....	8vo,	1 50
Short Course in Inorganic Qualitative Chemical Analysis for Engineering Students.....	12mo,	1 50
Whipple's Microscopy of Drinking-water.....	8vo,	3 50
Wiechmann's Sugar Analysis.....	Small 8vo.	2 50
Wilson's Cyanide Processes.....	12mo,	1 50
Chlorination Process.....	12mo,	1 50
Wulling's Elementary Course in Inorganic Pharmaceutical and Medical Chem- istry.....	12mo,	2 00

CIVIL ENGINEERING.

BRIDGES AND ROOFS. HYDRAULICS. MATERIALS OF ENGINEERING. RAILWAY ENGINEERING.

Baker's Engineers' Surveying Instruments.....	12mo,	3 00
Bixby's Graphical Computing Table.....	Paper, 19½ × 24½ inches	25
** Burr's Ancient and Modern Engineering and the Isthmian Canal. (Postage 27 cents additional.).....	8vo, n	3 50
Comstock's Field Astronomy for Engineers.....	8vo,	2 50
Davis's Elevation and Stadia Tables.....	8vo,	1 00
Elliott's Engineering for Land Drainage.....	12mo,	1 50
Practical Farm Drainage.....	12mo,	1 00
Folwell's Sewerage. (Designing and Maintenance.).....	8vo,	3 00
Freitag's Architectural Engineering. 2d Edition, Rewritten.....	8vo,	3 50
French and Ives's Stereotomy.....	8vo,	2 50
Goodhue's Municipal Improvements.....	12mo,	1 75
Goodrich's Economic Disposal of Towns' Refuse.....	8vo,	3 50
Gore's Elements of Geodesy.....	8vo,	2 50
Hayford's Text-book of Geodetic Astronomy.....	8vo,	3 00
Howe's Retaining Walls for Earth.....	12mo,	1 25
Johnson's Theory and Practice of Surveying.....	Small 8vo,	4 00
Statics by Algebraic and Graphic Methods.....	8vo,	2 00
Kiersted's Sewage Disposal.....	12mo,	1 25
Laplace's Philosophical Essay on Probabilities. (Truscott and Emory.)	12mo,	2 00
Mahan's Treatise on Civil Engineering. (1873.) (Wood.).....	8vo,	5 00
* Descriptive Geometry.....	8vo,	1 50
Merriman's Elements of Precise Surveying and Geodesy.....	8vo,	2 50
Elements of Sanitary Engineering.....	8vo,	2 00
Merriman and Brooks's Handbook for Surveyors.....	16mo, morocco,	2 00
Nugent's Plane Surveying.....	8vo,	3 50
Ogden's Sewer Design.....	12mo,	2 00
Patton's Treatise on Civil Engineering.....	8vo, half leather,	7 50
Reed's Topographical Drawing and Sketching.....	4to,	5 00
Rideal's Sewage and the Bacterial Purification of Sewage.....	8vo,	3 50
Siebert and Biggin's Modern Stone-cutting and Masonry.....	8vo,	1 50
Smith's Manual of Topographical Drawing. (McMillan.).....	8vo,	2 50

Sondericker's Graphic Statics, with Applications to Trusses, Beams, and Arches. (<i>Shortly.</i>)		
* Trautwine's Civil Engineer's Pocket-book	16mo, morocco,	5 00
Wait's Engineering and Architectural Jurisprudence	8vo,	6 00
	Sheep,	6 50
Law of Operations Preliminary to Construction in Engineering and Architecture	8vo,	5 00
	Sheep,	5 50
Law of Contracts	8vo,	3 00
Warren's Stereotomy—Problems in Stone-cutting	8vo,	2 50
Webb's Problems in the Use and Adjustment of Engineering Instruments	16mo, morocco,	1 25
* Wheeler's Elementary Course of Civil Engineering	8vo,	4 00
Wilson's Topographic Surveying	8vo,	3 50

BRIDGES AND ROOFS.

Boller's Practical Treatise on the Construction of Iron Highway Bridges	8vo,	2 00
* Thames River Bridge	4to, paper,	5 00
Burr's Course on the Stresses in Bridges and Roof Trusses, Arched Ribs, and Suspension Bridges	8vo,	3 50
Du Bois's Mechanics of Engineering. Vol. II	Small 4to,	10 00
Foster's Treatise on Wooden Trestle Bridges	4to,	5 00
Fowler's Cofferdam Process for Piers	8vo,	2 50
Greene's Roof Trusses	8vo,	1 25
Bridge Trusses	8vo,	2 50
Arches in Wood, Iron, and Stone	8vo,	2 50
Howe's Treatise on Arches	8vo,	4 00
Design of Simple Roof-trusses in Wood and Steel	8vo,	2 00
Johnson, Bryan, and Turneure's Theory and Practice in the Designing of Modern Framed Structures	Small 4to,	10 00
Merriman and Jacoby's Text-book on Roofs and Bridges:		
Part I.—Stresses in Simple Trusses	8vo,	2 50
Part II.—Graphic Statics	8vo,	2 50
Part III.—Bridge Design. 4th Edition, Rewritten	8vo,	2 50
Part IV.—Higher Structures	8vo,	2 50
Morison's Memphis Bridge	4to,	10 00
Waddell's De Pontibus, a Pocket-book for Bridge Engineers	16mo, morocco,	3 00
Specifications for Steel Bridges	12mo,	1 25
Wood's Treatise on the Theory of the Construction of Bridges and Roofs	8vo,	2 00
Wright's Designing of Draw-spans:		
Part I.—Plate-girder Draws	8vo,	2 50
Part II.—Riveted-truss and Pin-connected Long-span Draws	8vo,	2 50
Two parts in one volume	8vo,	3 50

HYDRAULICS.

Bazin's Experiments upon the Contraction of the Liquid Vein Issuing from an Orifice. (Trautwine.)	8vo,	2 00
Bovey's Treatise on Hydraulics	8vo,	5 00
Church's Mechanics of Engineering	8vo,	6 00
Diagrams of Mean Velocity of Water in Open Channels	paper,	1 50
Coffin's Graphical Solution of Hydraulic Problems	16mo, morocco,	2 50
Flather's Dynamometers, and the Measurement of Power	12mo,	3 00
Folwell's Water-supply Engineering	8vo,	4 00
Frizell's Water-power	8vo,	5 00

Fuertes's Water and Public Health.....	12mo,	1 50
Water-filtration Works.....	12mo,	2 50
Ganguillet and Kutter's General Formula for the Uniform Flow of Water in Rivers and Other Channels. (Hering and Trautwine.).....	8vo,	4 00
Hazen's Filtration of Public Water-supply.....	8vo,	3 00
Hazlehurst's Towers and Tanks for Water-works.....	8vo,	2 50
Herschel's 115 Experiments on the Carrying Capacity of Large, Riveted, Metal Conduits.....	8vo,	2 00
Mason's Water-supply. (Considered Principally from a Sanitary Standpoint.) 3d Edition, Rewritten.....	8vo,	4 00
Merriman's Treatise on Hydraulics. 9th Edition, Rewritten.....	8vo,	5 00
* Michie's Elements of Analytical Mechanics.....	8vo,	4 00
Schuyler's Reservoirs for Irrigation, Water-power, and Domestic Water-supply.....	Large 8vo,	5 00
** Thomas and Watt's Improvement of Riyers. (Post., 44 c. additional), 4to,		6 00
Turneure and Russell's Public Water-supplies.....	8vo,	5 00
Wegmann's Design and Construction of Dams.....	4to,	5 00
Water-supply of the City of New York from 1658 to 1895.....	4to,	10 00
Weisbach's Hydraulics and Hydraulic Motors. (Du Bois.).....	8vo,	5 00
Wilson's Manual of Irrigation Engineering.....	Small 8vo,	4 00
Wolff's Windmill as a Prime Mover.....	8vo,	3 00
Wood's Turbines.....	8vo,	2 50
Elements of Analytical Mechanics.....	8vo,	3 00

MATERIALS OF ENGINEERING.

Baker's Treatise on Masonry Construction.....	8vo,	5 00
Roads and Pavements.....	8vo,	5 00
Black's United States Public Works.....	Oblong 4to,	5 00
Bovey's Strength of Materials and Theory of Structures.....	8vo,	7 50
Burr's Elasticity and Resistance of the Materials of Engineering. 6th Edition, Rewritten.....	8vo,	7 50
Byrne's Highway Construction.....	8vo,	5 00
Inspection of the Materials and Workmanship Employed in Construction.	16mo,	3 00
Church's Mechanics of Engineering.....	8vo,	6 00
Du Bois's Mechanics of Engineering. Vol. I.....	Small 4to,	7 50
Johnson's Materials of Construction.....	Large 8vo,	6 00
Keep's Cast Iron.....	8vo,	2 50
Lanza's Applied Mechanics.....	8vo,	7 50
Martens's Handbook on Testing Materials. (Henning.) 2 vols.....	8vo,	7 50
Merrill's Stones for Building and Decoration.....	8vo,	5 00
Merriman's Text-book on the Mechanics of Materials.....	8vo,	4 00
Strength of Materials.....	12mo,	1 00
Metcalf's Steel. A Manual for Steel-users.....	12mo,	2 00
Patton's Practical Treatise on Foundations.....	8vo,	5 00
Rockwell's Roads and Pavements in France.....	12mo,	1 25
Smith's Wire: Its Use and Manufacture.....	Small 4to,	3 00
Materials of Machines.....	12mo,	1 00
Snow's Principal Species of Wood.....	8vo,	3 50
Spalding's Hydraulic Cement.....	12mo,	2 00
Text-book on Roads and Pavements.....	12mo,	2 00
Thurston's Materials of Engineering. 3 Parts.....	8vo,	8 00
Part I.—Non-metallic Materials of Engineering and Metallurgy....	8vo,	2 00
Part II.—Iron and Steel.....	8vo,	3 50
Part III.—A Treatise on Brasses, Bronzes, and Other Alloys and their Constituents.....	8vo,	2 50

Thurston's Text-book of the Materials of Construction	8vo,	5 00
Tillson's Street Pavements and Paving Materials.....	8vo,	4 00
Waddell's De Pontibus. (A Pocket-book for Bridge Engineers.)..	16mo, mor.,	3 00
Specifications for Steel Bridges.....	12mo,	1 25
Wood's Treatise on the Resistance of Materials, and an Appendix on the Pres- ervation of Timber.....	8vo,	2 00
Elements of Analytical Mechanics.....	8vo,	3 00

RAILWAY ENGINEERING.

Andrews's Handbook for Street Railway Engineers. 3×5 inches. morocco,		1 25
Berg's Buildings and Structures of American Railroads.....	4to,	5 00
Brooks's Handbook of Street Railroad Location.....	16mo. morocco,	1 50
Butts's Civil Engineer's Field-book.....	16mo, morocco,	2 50
Crandall's Transition Curve.....	16mo, morocco,	1 50
Railway and Other Earthwork Tables.....	8vo,	1 50
Dawson's "Engineering" and Electric Traction Pocket-book. 16mo, morocco,		4 00
Dredge's History of the Pennsylvania Railroad: (1879).....	Paper,	5 00
* Drinker's Tunneling, Explosive Compounds, and Rock Drills, 4to, half mor.,		25 00
Fisher's Table of Cubic Yards.....	Cardboard,	25
Godwin's Railroad Engineers' Field-book and Explorers' Guide....	16mo, mor.,	2 50
Howard's Transition Curve Field-book.....	16mo morocco	1 50
Hudson's Tables for Calculating the Cubic Contents of Excavations and Em- bankments	8vo,	1 00
Molitor and Beard's Manual for Resident Engineers:.....	16mo,	1 00
Nagle's Field Manual for Railroad Engineers.....	16mo, morocco.	3 00
Philbrick's Field Manual for Engineers.....	16mo, morocco,	3 00
Pratt and Alden's Street-railway Road-bed.....	8vo,	2 00
Searles's Field Engineering.....	16mo, morocco,	3 00
Railroad Spiral.....	16mo, morocco	1 50
Taylor's Prismoidal Formulæ and Earthwork.....	8vo,	1 50
* Trautwine's Method of Calculating the Cubic Contents of Excavations and Embankments by the Aid of Diagrams.....	8vo,	2 00
The Field Practice of Laying Out Circular Curves for Railroads.	12mo, morocco,	2 50
* Cross-section Sheet.....	Paper,	25
Webb's Railroad Construction. 2d Edition, Rewritten.....	16mo. morocco,	5 00
Wellington's Economic Theory of the Location of Railways.....	Small 8vo,	5 00

DRAWING.

Barr's Kinematics of Machinery.....	8vo,	2 50
* Bartlett's Mechanical Drawing.	8vo,	3 00
Coolidge's Manual of Drawing.....	8vo, paper,	1 00
Durley's Kinematics of Machines.....	8vo,	4 00
Hill's Text-book on Shades and Shadows, and Perspective.....	8vo,	2 00
Jones's Machine Design:		
Part I.—Kinematics of Machinery.....	8vo,	1 50
Part II.—Form, Strength, and Proportions of Parts.....	8vo,	3 00
MacCord's Elements of Descriptive Geometry.....	8vo,	3 00
Kinematics; or, Practical Mechanism.....	8vo,	5 00
Mechanical Drawing.....	4to,	4 00
Velocity Diagrams.....	8vo,	1 50
* Mahan's Descriptive Geometry and Stone-cutting.....	8vo,	1 50
Industrial Drawing. (Thompson.).....	8vo,	3 50
Reed's Topographical Drawing and Sketching.....	4to,	5 00

Reid's Course in Mechanical Drawing.....	8vo,	2 00
Text-book of Mechanical Drawing and Elementary Machine Design..	8vo,	3 00
Robinson's Principles of Mechanism.....	8vo,	3 00
Smith's Manual of Topographical Drawing. (McMillan.).....	8vo,	2 50
Warren's Elements of Plane and Solid Free-hand Geometrical Drawing..	12mo,	1 00
Drafting Instruments and Operations.....	12mo,	1 25
Manual of Elementary Projection Drawing.....	12mo,	1 50
Manual of Elementary Problems in the Linear Perspective of Form and Shadow.....	12mo,	1 00
Plane Problems in Elementary Geometry.....	12mo,	1 25
Primary Geometry	12mo,	75
Elements of Descriptive Geometry, Shadows, and Perspective.....	8vo,	3 50
General Problems of Shades and Shadows.....	8vo,	3 00
Elements of Machine Construction and Drawing.....	8vo,	7 50
Problems, Theorems, and Examples in Descriptive Geometry.....	8vo,	2 50
Weisbach's Kinematics and the Power of Transmission. (Hermann and Klein.)	8vo,	5 00
Whelpley's Practical Instruction in the Art of Letter Engraving.....	12mo,	2 00
Wilson's Topographic Surveying.....	8vo,	3 50
Free-hand Perspective.....	8vo,	2 50
Free-hand Lettering. (<i>In preparation.</i>)		
Woolf's Elementary Course in Descriptive Geometry.....	Large 8vo,	3 00

ELECTRICITY AND PHYSICS.

Anthony and Brackett's Text-book of Physics. (Magie.).....	Small 8vo,	3 00
Anthony's Lecture-notes on the Theory of Electrical Measurements.....	12mo,	1 00
Benjamin's History of Electricity.....	8vo,	3 00
Voltaic Cell.....	8vo,	3 00
Classen's Quantitative Chemical Analysis by Electrolysis. (Boltwood.)..	8vo,	3 00
Crehore and Squier's Polarizing Photo-chronograph.....	8vo,	3 00
Dawson's "Engineering" and Electric Traction Pocket-book..	10mo, morocco,	4 00
Flather's Dynamometers, and the Measurement of Power.....	12mo,	3 00
Gilbert's De Magnete. (Mottelay.).....	8vo,	2 50
Holman's Precision of Measurements.....	8vo,	2 00
Telescopic Mirror-scale Method, Adjustments, and Tests....	Large 8vo	75
Landauer's Spectrum Analysis. (Tingle.).....	8vo,	3 00
Le Chatelier's High-temperature Measurements. (Boudouard—Burgess.)	12mo,	3 00
Löb's Electrolysis and Electrosynthesis of Organic Compounds. (Lorenz.)	12mo,	1 00
* Lyons's Treatise on Electromagnetic Phenomena. Vols. I. and II. 8vo, each,	6	00
* Michie. Elements of Wave Motion Relating to Sound and Light.....	8vo,	4 00
Niaudet's Elementary Treatise on Electric Batteries. (Fishback.).....	12mo,	2 50
* Parshall and Hobart's Electric Generators.....	Small 4to. half morocco,	10 00
* Rosenberg's Electrical Engineering. (Haldane Gee—Kinzbrunner.)...	8vo,	1 50
Ryan, Norris, and Hoxie's Electrical Machinery. (<i>In preparation.</i>)		
Thurston's Stationary Steam-engines.....	8vo,	2 50
* Tillman's Elementary Lessons in Heat.....	8vo,	1 50
Tory and Pitcher's Manual of Laboratory Physics.....	Small 8vo,	2 00
Ulke's Modern Electrolytic Copper Refining	8vo,	3 00

LAW.

* Davis's Elements of Law	8vo,	2 50
* Treatise on the Military Law of United States.....	8vo,	7 00
*	Sheep,	7 50
Manual for Courts-martial.....	16mo, morocco,	1 50

Wait's Engineering and Architectural Jurisprudence.....	8vo,	6 00
	Sheep,	6 50
Law of Operations Preliminary to Construction in Engineering and Architecture.....	8vo,	5 00
	Sheep,	5 50
Law of Contracts.....	8vo,	3 00
Winthrop's Abridgment of Military Law.....	12mo,	2 50

MANUFACTURES.

Bernadou's Smokeless Powder—Nitro-cellulose and Theory of the Cellulose Molecule.....	12mo,	2 50
Bolland's Iron Founder.....	12mo,	2 50
"The Iron Founder," Supplement.....	12mo,	2 50
Encyclopedia of Founding and Dictionary of Foundry Terms Used in the Practice of Moulding.....	12mo,	3 00
Eissler's Modern High Explosives.....	8vo,	4 00
Effront's Enzymes and their Applications. (Prescott.).....	8vo,	3 00
Fitzgerald's Boston Machinist.....	18mo,	1 00
Ford's Boiler Making for Boiler Makers.....	18mo,	1 00
Hopkins's Oil-chemists' Handbook.....	8vo,	3 00
Keep's Cast Iron.....	8vo,	2 50
Leach's The Inspection and Analysis of Food with Special Reference to State Control. (<i>In preparation.</i>)		
Metcalf's Steel. A Manual for Steel-users.....	12mo,	2 00
Metcalf's Cost of Manufactures—And the Administration of Workshops, Public and Private.....	8vo,	5 00
Meyer's Modern Locomotive Construction.....	4to,	10 00
* Reisig's Guide to Piece-dyeing.....	8vo,	25 00
Smith's Press-working of Metals.....	8vo,	3 00
Wire: Its Use and Manufacture.....	Small 4to,	3 00
Spalding's Hydraulic Cement.....	12mo,	2 00
Spencer's Handbook for Chemists of Beet-sugar Houses....	16mo, morocco,	3 00
Handbook for Sugar Manufacturers and their Chemists...	16mo, morocco,	2 00
Thurston's Manual of Steam-boilers, their Designs, Construction and Operation.....	8vo,	5 00
* Walke's Lectures on Explosives.....	8vo,	4 00
West's American Foundry Practice.....	12mo,	2 50
Moulder's Text-book.....	12mo,	2 50
Wiechmann's Sugar Analysis.....	Small 8vo,	2 50
Wolff's Windmill as a Prime Mover.....	8vo,	3 00
Woodbury's Fire Protection of Mills.....	8vo,	2 50

MATHEMATICS.

Baker's Elliptic Functions.....	8vo,	1 50
* Bass's Elements of Differential Calculus.....	12mo,	4 00
Briggs's Elements of Plane Analytic Geometry.....	12mo,	1 00
Chapman's Elementary Course in Theory of Equations.....	12mo,	1 50
Compton's Manual of Logarithmic Computations.....	12mo,	1 50
Davis's Introduction to the Logic of Algebra.....	8vo,	1 50
* Dickson's College Algebra.....	Large 12mo,	1 50
* Introduction to the Theory of Algebraic Equations.....	Large 12mo,	1 25
Halsted's Elements of Geometry.....	8vo,	1 75
Elementary Synthetic Geometry.....	8vo,	1 50

* Johnson's Three-place Logarithmic Tables: Vest-pocket size..... paper,	1	15
	100 copies for	5 00
* Mounted on heavy cardboard, 8×10 inches,		25
	10 copies for	2 00
Elementary Treatise on the Integral Calculus.....	Small 8vo,	1 50
Curve Tracing in Cartesian Co-ordinates.....	12mo,	1 00
Treatise on Ordinary and Partial Differential Equations.....	Small 8vo,	3 50
Theory of Errors and the Method of Least Squares.....	12mo,	1 50
* Theoretical Mechanics.....	12mo,	3 00
Laplace's Philosophical Essay on Probabilities. (Truscott and Emory.)	12mo,	2 00
* Ludlow and Bass. Elements of Trigonometry and Logarithmic and Other Tables.....	8vo,	3 00
Trigonometry and Tables published separately.....	Each,	2 00
Maurer's Technical Mechanics. (<i>In preparation.</i>)		
Merriman and Woodward's Higher Mathematics.....	8vo,	5 00
Merriman's Method of Least Squares.....	8vo,	2 00
Rice and Johnson's Elementary Treatise on the Differential Calculus. Sm.,	8vo,	3 00
Differential and Integral Calculus. 2 vols. in one.....	Small 8vo,	2 50
Wood's Elements of Co-ordinate Geometry.....	8vo,	2 00
Trigonometry: Analytical, Plane, and Spherical.....	12mo,	1 00

MECHANICAL ENGINEERING.

MATERIALS OF ENGINEERING, STEAM-ENGINES AND BOILERS.

Baldwin's Steam Heating for Buildings.....	12mo,	2 50
Barr's Kinematics of Machinery.....	8vo,	2 50
* Bartlett's Mechanical Drawing.....	8vo,	3 00
Benjamin's Wrinkles and Recipes.....	12mo,	2 00
Carpenter's Experimental Engineering.....	8vo,	6 00
Heating and Ventilating Buildings.....	8vo,	4 00
Clerk's Gas and Oil Engine.....	Small 8vo,	4 00
Coolidge's Manual of Drawing.....	8vo, paper,	1 00
Cromwell's Treatise on Toothed Gearing.....	12mo,	1 50
Treatise on Belts and Pulleys.....	12mo,	1 50
Durley's Kinematics of Machines.....	8vo,	4 00
Flather's Dynamometers and the Measurement of Power.....	12mo,	3 00
Rope Driving.....	12mo,	2 00
Gill's Gas and Fuel Analysis for Engineers.....	12mo,	1 25
Hall's Car Lubrication.....	12mo,	1 00
Hutton's The Gas Engine. (<i>In preparation.</i>)		
Jones's Machine Design:		
Part I.—Kinematics of Machinery.....	8vo,	1 50
Part II.—Form, Strength, and Proportions of Parts.....	8vo,	3 00
Kent's Mechanical Engineer's Pocket-book.....	16mo, morocco,	5 00
Kerr's Power and Power Transmission.....	8vo,	2 00
MacCord's Kinematics; or, Practical Mechanism.....	8vo,	5 00
Mechanical Drawing.....	4to,	4 00
Velocity Diagrams.....	8vo,	1 50
Mahan's Industrial Drawing. (Thompson.).....	8vo,	3 50
Poole's Calorific Power of Fuels.....	8vo,	3 00
Reid's Course in Mechanical Drawing.....	8vo,	2 00
Text-book of Mechanical Drawing and Elementary Machine Design.....	8vo,	3 00
Richards's Compressed Air.....	12mo,	1 50
Robinson's Principles of Mechanism.....	8vo,	3 00
Smith's Press-working of Metals.....	8vo,	3 00
Thurston's Treatise on Friction and Lost Work in Machinery and Mil Work.....	8vo,	3 00
Animal as a Machine and Prime Motor, and the Laws of Energetics.....	12mo,	1 00

Warren's Elements of Machine Construction and Drawing.....	8vo,	7 50
Weisbach's Kinematics and the Power of Transmission. Herrmann— Klein.).....	8vo,	5 00
Machinery of Transmission and Governors. (Herrmann—Klein.)..	8vo,	5 00
Hydraulics and Hydraulic Motors. (Du Bois.).....	8vo,	5 00
Wolff's Windmill as a Prime Mover.....	8vo,	3 00
Wood's Turbines.....	8vo,	2 50

MATERIALS OF ENGINEERING.

Bovey's Strength of Materials and Theory of Structures.....	8vo,	7 50
Burr's Elasticity and Resistance of the Materials of Engineering. 6th Edition, Reset.....	8vo,	7 50
Church's Mechanics of Engineering.....	8vo,	6 00
Johnson's Materials of Construction.....	Large 8vo,	6 00
Keep's Cast Iron.....	8vo	2 50
Lanza's Applied Mechanics.....	8vo,	7 50
Martens's Handbook on Testing Materials. (Henning.).....	8vo,	7 50
Merriman's Text-book on the Mechanics of Materials.....	8vo,	4 00
Strength of Materials.....	12mo,	1 00
Metcalf's Steel. A Manual for Steel-users.....	12mo.	2 00
Smith's Wire: Its Use and Manufacture.....	Small 4to,	3 00
Materials of Machines.....	12mo,	1 00
Thurston's Materials of Engineering.....	3 vols., 8vo	8 00
Part II.—Iron and Steel.....	8vo,	3 50
Part III.—A Treatise on Brasses, Bronzes, and Other Alloys and their Constituents.....	8vo,	2 50
Text-book of the Materials of Construction.....	8vo	5 00
Wood's Treatise on the Resistance of Materials and an Appendix on the Preservation of Timber.....	8vo,	2 00
Elements of Analytical Mechanics.....	8vo,	3 00

STEAM-ENGINES AND BOILERS.

Carnot's Reflections on the Motive Power of Heat. (Thurston.).....	12mo,	1 50
Dawson's "Engineering" and Electric Traction Pocket-book..	16mo, mor.,	4 00
Ford's Boiler Making for Boiler Makers.....	18mo,	1 00
Goss's Locomotive Sparks.....	8vo,	2 00
Hemenway's Indicator Practice and Steam-engine Economy.....	12mo,	2 00
Hutton's Mechanical Engineering of Power Plants.....	8vo,	5 00
Heat and Heat-engines.....	8vo,	5 00
Kent's Steam-boiler Economy.....	8vo,	4 00
Kneass's Practice and Theory of the Injector.....	8vo.	1 50
MacCord's Slide-valves.....	8vo,	2 00
Meyer's Modern Locomotive Construction.....	4to,	10 00
Peabody's Manual of the Steam-engine Indicator.....	12mo,	1 50
Tables of the Properties of Saturated Steam and Other Vapors.....	8vo,	1 00
Thermodynamics of the Steam-engine and Other Heat-engines.....	8vo,	5 00
Valve-gears for Steam-engines.....	8vo,	2 50
Peabody and Miller's Steam-boilers.....	8vo,	4 00
Pray's Twenty Years with the Indicator.....	Large 8vo,	2 50
Pupln's Thermodynamics of Reversible Cycles in Gases and Saturated Vapors. (Osterberg.).....	12mo,	1 25
Reagan's Locomotives: Simple, Compound, and Electric.....	12mo,	2 50
Rontgen's Principles of Thermodynamics. (Du Bois.).....	8vo,	5 00
Sinclair's Locomotive Engine Running and Management.....	12mo,	2 00
Smart's Handbook of Engineering Laboratory Practice.....	12mo,	2 50
Snow's Steam-boiler Practice.....	8vo,	3 00

Spangler's Valve-gears.	8vo,	2 50
Notes on Thermodynamics.	12mo,	1 00
Spangler, Greene, and Marshall's Elements of Steam-engineering.	8vo,	3 00
Thurston's Handy Tables.	8vo,	1 50
Manual of the Steam-engine.	2 vols. 8vo	10 00
Part I.—History, Structure, and Theory.	8vo,	6 00
Part II.—Design, Construction, and Operation.	8vo,	6 00
Handbook of Engine and Boiler Trials, and the Use of the Indicator and the Prony Brake.	8vo	5 00
Stationary Steam-engines.	8vo,	2 50
Steam-boiler Explosions in Theory and in Practice.	12mo,	1 50
Manual of Steam-boilers, Their Designs, Construction, and Operation.	8vo,	5 00
Weisbach's Heat, Steam, and Steam-engines. (Du Bois.)	8vo,	5 00
Whitham's Steam-engine Design.	8vo,	5 00
Wilson's Treatise on Steam-boilers. (Flather.)	16mo,	2 50
Wood's Thermodynamics. Heat Motors, and Refrigerating Machines.	8vo,	4 00

MECHANICS AND MACHINERY.

Barr's Kinematics of Machinery.	8vo,	2 50
Bovey's Strength of Materials and Theory of Structures.	8vo,	7 50
Chase's The Art of Pattern-making.	12mo,	2 50
Chordal.—Extracts from Letters.	12mo,	2 00
Church's Mechanics of Engineering.	8vo	6 00
Notes and Examples in Mechanics.	8vo.	2 00
Compton's First Lessons in Metal-working.	12mo,	1 50
Compton and De Groot's The Speed Lathe.	12mo,	1 50
Cromwell's Treatise on Toothed Gearing.	12mo,	1 50
Treatise on Belts and Pulleys.	12mo,	1 50
Dana's Text-book of Elementary Mechanics for the Use of Colleges and Schools.	12mo,	1 50
Dingey's Machinery Pattern Making.	12mo,	2 00
Dredge's Record of the Transportation Exhibits Building of the World's Columbian Exposition of 1893.	4to, half morocco,	5 00
Du Bois's Elementary Principles of Mechanics:		
Vol. I.—Kinematics.	8vo,	3 50
Vol. II.—Statics.	8vo,	4 00
Vol. III.—Kinetics.	8vo,	3 50
Mechanics of Engineering. Vol. I.	Small 4to,	7 50
Vol. II.	Small 4to,	10 00
Durley's Kinematics of Machines.	8vo,	4 00
Fitzgerald's Boston Machinist.	16mo,	1 00
Flather's Dynamometers, and the Measurement of Power.	12mo,	3 00
Rope Driving.	12mo,	2 00
Goss's Locomotive Sparks.	8vo,	2 00
Hall's Car Lubrication.	12mo,	1 00
Holly's Art of Saw Filing.	18mo	75
* Johnson's Theoretical Mechanics.	12mo,	3 00
Statics by Graphic and Algebraic Methods.	8vo,	2 00
Jones's Machine Design:		
Part I.—Kinematics of Machinery.	8vo,	1 50
Part II.—Form, Strength, and Proportions of Parts.	8vo,	3 00
Kerr's Power and Power Transmission.	8vo,	2 00
Lanza's Applied Mechanics.	8vo,	7 50
MacCord's Kinematics; or, Practical Mechanism.	8vo,	5 00
Velocity Diagrams.	8vo,	1 50
Maurer's Technical Mechanics. (<i>In preparation.</i>)		

Merriman's Text-book on the Mechanics of Materials.....	8vo,	4 00
* Michie's Elements of Analytical Mechanics.....	8vo,	4 00
Reagan's Locomotives: Simple, Compound, and Electric.....	12mo,	2 50
Reid's Course in Mechanical Drawing.....	8vo,	2 00
Text-book of Mechanical Drawing and Elementary Machine Design..	8vo,	3 00
Richards's Compressed Air.....	12mo,	1 50
Robinson's Principles of Mechanism.....	8vo,	3 00
Ryan, Norris, and Hoxie's Electrical Machinery. (<i>In preparation.</i>)		
Sinclair's Locomotive-engine Running and Management.....	12mo,	2 00
Smith's Press-working of Metals.....	8vo,	3 00
Materials of Machines.....	12mo,	1 00
Spangler, Greene, and Marshall's Elements of Steam-engineering.....	8vo,	3 00
Thurston's Treatise on Friction and Lost Work in Machinery and Mill Work.....	8vo,	3 00
Animal as a Machine and Prime Motor, and the Laws of Energetics.	12mo,	1 00
Warren's Elements of Machine Construction and Drawing.....	8vo,	7 50
Weisbach's Kinematics and the Power of Transmission. (Herrmann— Klein.).....	8vo,	5 00
Machinery of Transmission and Governors. (Herrmann—Klein.)	8vo,	5 00
Wood's Elements of Analytical Mechanics.....	8vo,	3 00
Principles of Elementary Mechanics.....	12mo,	1 25
Turbines.....	8vo,	2 50
The World's Columbian Exposition of 1893.....	4to,	1 00

METALLURGY.

Egleston's Metallurgy of Silver, Gold, and Mercury:		
Vol. I.—Silver.....	8vo,	7 50
Vol. II.—Gold and Mercury.....	8vo,	7 50
** Iles's Lead-smelting. (Postage 9 cents additional.).....	12mo,	2 50
Keep's Cast Iron.....	8vo,	2 50
Kunhardt's Practice of Ore Dressing in Europe.....	8vo,	1 50
Le Chatelier's High-temperature Measurements. (Boudouard—Burgess.)	12mo,	3 00
Metcalf's Steel. A Manual for Steel-users.....	12mo,	2 00
Smith's Materials of Machines.....	12mo,	1 00
Thurston's Materials of Engineering. In Three Parts.....	8vo,	8 00
Part II.—Iron and Steel.....	8vo,	3 50
Part III.—A Treatise on Brasses, Bronzes, and Other Alloys and their Constituents.....	8vo,	2 50
Ulke's Modern Electrolytic Copper Refining.....	8vo,	3 00

MINERALOGY.

Barringer's Description of Minerals of Commercial Value. Oblong, morocco,		2 50
Boyd's Resources of Southwest Virginia.....	8vo,	3 00
Map of Southwest Virginia.....	Pocket-book form,	2 00
Brush's Manual of Determinative Mineralogy. (Penfield.).....	8vo,	4 00
Chester's Catalogue of Minerals.....	8vo, paper,	1 00
Dictionary of the Names of Minerals.....	Cloth,	1 25
8vo,		3 50
Dana's System of Mineralogy.....	Large 8vo, half leather,	12 50
First Appendix to Dana's New "System of Mineralogy."....	Large 8vo,	1 00
Text-book of Mineralogy.....	8vo,	4 00
Minerals and How to Study Them.....	12mo,	1 50
Catalogue of American Localities of Minerals.....	Large 8vo,	1 00
Manual of Mineralogy and Petrography.....	12mo,	2 00
Egleston's Catalogue of Minerals and Synonyms.....	8vo,	2 50
Hussak's The Determination of Rock-forming Minerals. (Smith.) Small	8vo,	2 00

* Penfield's Notes on Determinative Mineralogy and Record of Mineral Tests.	8vo, paper,	0 50
Rosenbusch's Microscopical Physiography of the Rock-making Minerals. (Iddings.)	8vo,	5 00
* Tillman's Text-book of Important Minerals and Docks.	8vo,	2 00
Williams's Manual of Lithology.	8vo,	3 00

MINING.

Beard's Ventilation of Mines.	12mo,	2 50
Boyd's Resources of Southwest Virginia.	8vo,	3 00
Map of Southwest Virginia.	Pocket-book form,	2 00
* Drinker's Tunneling, Explosive Compounds, and Rock Drills.	4to, half morocco,	25 00
Eissler's Modern High Explosives.	8vo,	4 00
Fowler's Sewage Works Analyses.	12mo,	2 00
Goodyear's Coal-mines of the Western Coast of the United States.	12mo,	2 50
Ihlseng's Manual of Mining.	8vo,	4 00
** Iles's Lead-smelting. (Postage 9c. additional.)	12mo,	2 50
Kunhardt's Practice of Ore Dressing in Europe.	8vo,	1 50
O'Driscoll's Notes on the Treatment of Gold Ores.	8vo,	2 00
* Walke's Lectures on Explosives.	8vo,	4 00
Wilson's Cyanide Processes.	12mo,	1 50
Chlorination Process.	12mo,	1 50
Hydraulic and Placer Mining.	12mo,	2 00
Treatise on Practical and Theoretical Mine Ventilation.	12mo,	1 25

SANITARY SCIENCE.

Copeland's Manual of Bacteriology. (<i>In preparation.</i>)		
Folwell's Sewerage. (Designing, Construction, and Maintenance.)	8vo,	3 00
Water-supply Engineering.	8vo,	4 00
Fuertes's Water and Public Health.	12mo,	1 50
Water-filtration Works.	12mo,	2 50
Gerhard's Guide to Sanitary House-inspection.	16mo,	1 00
Goodrich's Economical Disposal of Town's Refuse.	Demy 8vo,	3 50
Hazen's Filtration of Public Water-supplies.	8vo,	3 00
Kiersted's Sewage Disposal.	12mo,	1 25
Leach's The Inspection and Analysis of Food with Special Reference to State Control. (<i>In preparation.</i>)		
Mason's Water-supply. (Considered Principally from a Sanitary Standpoint.) 3d Edition, Rewritten	8vo,	4 00
Examination of Water. (Chemical and Bacteriological.)	12mo,	1 25
Merriman's Elements of Sanitary Engineering.	8vo,	2 00
Nichols's Water-supply. (Considered Mainly from a Chemical and Sanitary Standpoint.) (1883.)	8vo,	2 50
Ogden's Sewer Design.	12mo,	2 00
* Price's Handbook on Sanitation.	12mo,	1 50
Richards's Cost of Food. A Study in Dietaries.	12mo,	1 00
Cost of Living as Modified by Sanitary Science	12mo,	1 00
Richards and Woodman's Air, Water, and Food from a Sanitary Standpoint.	8vo,	2 00
* Richards and Williams's The Dietary Computer.	8vo,	1 50
Rideal's Sewage and Bacterial Purification of Sewage.	8vo,	3 50
Turneure and Russell's Public Water-supplies.	8vo,	5 00
Whipple's Microscopy of Drinking-water.	8vo,	3 50
Woodhull's Notes and Military Hygiene.	16mo,	1 50

MISCELLANEOUS.

Barker's Deep-sea Soundings.....	8vo,	2 00
Emmons's Geological Guide-book of the Rocky Mountain Excursion of the International Congress of Geologists.....	Large 8vo,	1 50
Ferrel's Popular Treatise on the Winds.....	8vo,	4 00
Haines's American Railway Management.....	12mo,	2 50
Mott's Composition, Digestibility, and Nutritive Value of Food. Mounted chart.		1 25
Fallacy of the Present Theory of Sound....	16mo,	1 00
Ricketts's History of Rensselaer Polytechnic Institute, 1824-1894. Small	8vo,	3 00
Rotherham's Emphasized New Testament.....	Large 8vo,	2 00
Steel's Treatise on the Diseases of the Dog.....	8vo,	3 50
Totten's Important Question in Metrology.....	8vo,	2 50
The World's Columbian Exposition of 1893.....	4to,	1 00
Worcester and Atkinson. Small Hospitals, Establishment and Maintenance, and Suggestions for Hospital Architecture, with Plans for a Small Hospital.....	12mo,	1 25

HEBREW AND CHALDEE TEXT-BOOKS.

Green's Grammar of the Hebrew Language.....	8vo,	3 00
Elementary Hebrew Grammar.....	12mo,	1 25
Hebrew Chrestomathy.....	8vo,	2 00
Gesenius's Hebrew and Chaldee Lexicon to the Old Testament Scriptures. (Tregelles.).....	Small 4to, half morocco,	5 00
Letteris's Hebrew Bible.....	8vo,	2 25

LIBRARY OF CONGRESS



0 021 606 975 4