

- 4 *A soft substance, depending from the Upper Part of the Uterus, into which the foresaid Vessels terminate.*
 - 5 *Two Tubercles, seated near the Beginnings of the Tube, to which the Placenta adher'd.*
 - BB *The Vagina laid open.*
 6. 6. *The two Labia of the Collum minus.*
 7. 7. *several small Glands plac'd on the Upper Labium.*
 8. *The Course of the Rugæ on the upper side of the Vagina.*
 9. 9. *Their direction on the under side of that part.*
 10. 10. *Two Orbicular Substances, near the Orifice of the Meatus Urinarius.*
-

III. *An Account of an Experiment made before the Royal Society at Gresham-Colledge, touching the Extraordinary Electricity of Glass, producible on a smart Attrition of it ; with a Continuation of Experiments on the same Subject, and other Phenomena. By Mr Fra. Hauksbee, F. R. S.*

I Took a Hollow Tube of fine Flint Glass, about an Inch Diameter and 30 in Length, which having rubb'd pretty smartly with Paper in my Hand, till it had acquir'd some degree of Heat ; it was then held towards some pieces of Leaf Brass, which so soon as its *Effluviu* had reacht, became suddenly in Motion, flying towards the Tube, even at 9 or 10 Inches distance ; and it seem'd that the hotter the Tube was made by Rubbing, the farther it would Attract, but that it would do so to any Degree of Heat, I dare not determine. And what farther observable was, That sometimes the Bodies Attracted would adhere to the Tube, and there remain quiet. Sometimes would be thrown violently from it to

good Distances: Sometimes in their Motions towards, and sometimes even touching it, they would suddenly be Repell'd back to the distance of 4 or 5 Inches, repeating the same several times with great Velocity in a very surprizing manner. Sometimes the Bodies would move but slowly towards the Tube, sometimes remain a small time suspended between the Glass and the Table on which the Brass Leaf was laid; and sometimes seem to slide along the sides of it without touching. All which *Phenomena*, altho they do not happen at every Tryal exactly as I have here deliver'd them, yet I have sometimes seen them, and in a great measure at all times, are very agreeable to this account, notwithstanding the Force and Vigour of the *Effluvium* is sometimes less than what at other times I have found it. The Reason of which seems to me to proceed from the Different Temperatures of the Air at the time the Experiments are made; for when it happens that abundance of Humid Particles (as sometimes there are) are swimming in the Air, there is no difficulty to believe, but the Resistance of such Particles may mightily impede the Force and Extent of the *Effluvium*: Or, which is much to the same purpose, suddenly Condense on the warm Tube, thereby Hindring or Choking the Passages of the *Effluvia*. For I find Moistness at all times an utter Enemy to Attempts of this nature; besides, the quality of the *Effluvium* seems to be such, that I could not (in an Experiment lately made) with all my endeavours, cause it to affect one of the premention'd Bodies thro a piece of fine Mullin, notwithstanding it was held very near it, and at the same time would Attract or give Motion to the same Body at three or four times that distance, the Mullin not interposing. Moreover, I cannot tell but the Coldness of the Air at the same time may Concur; for when this Experiment was first made it was Summer time, and Dry Weather; and then it seem'd to me to succeed something better than it has done

done of late : Yet the least of its Performances under the foremention'd Inconveniencies is very notable. But to proceed : When the Glass became hottest by the greatest Attrition, it did then send forth such quantity of *Effluvia*, not only performing the Effects before-mentioned with seemingly greater Vigour, but being nearly apply'd to the Face, or any tender part, might be sensibly felt, as if the Part was pusht with the points of a considerable number of weak Hairs. In this place I think it will not be amiss to take notice, That, considering the Vigorous Action of the *Effluvium*, I thought it would not be unnecessary to attempt a discovery of the figure of its Motion, by Approaching the Affricated Tube to the flame of a Candle, Smoak, Steem, Dust, and to the Surfaces of Liquids ; which I did without any manner of success : And which I wholly attribute to the reason before given, of the Humid *Effluvia* suddenly Condensing on the Warm Glass ; so the Oleagenous Quality of the Flame and Smoak, the Moistness of the Steam, the Smalness of the Dust, or the *Effluvia* of the Liquids, would immediately adhere to all parts of the Affricated Tube, as it was approacht within their Spheres, preventing the Operation of its *Effluvia*, which then seem'd to be stopt, or retir'd within itself ; and requir'd a new Attrition to give it vent.

What next occur'd in this Experiment was, That upon exhausting the Air from within the Tube by the Pump, then altho the like Attrition or greater was given it than before, yet very little of the *Affluvium* could be discoverable, by any motion or disturbance given the Leaf Brass, notwithstanding it was held within a quarter of the distance, at which it had been attracted before. After this had been continu'd for some time with little success : I say with little success, Because, sometimes small parts of the Leaf Brass, when the Tube was held near, and at the same time very warm, would
have

have a Motion given them; but without Comparison to what it did when the Experiment was made with it unexhausted of its Air. Besides, I doubt not but some small quantity of Air might be left in the Tube, and so the Attraction to continue in proportion to the Quantity of the remaining Air. Or the Heat that is produc'd upon the smart Attrition of it, may as well in this (I think) as in other Experiments, supply the Effect and Space of such a quantity of that Element: Upon letting in the Air again, it was worth taking notice, That before any new attrition was given the Tube, or was remov'd from the Position and Distance it was held in when *in Vacuo*, that several of the premention'd Bodies at Rest, (as to fence) began suddenly to move, and were some of them attracted to the Tube, which, upon a fresh attrition, its Electrical Quality recover'd as vigorous as at first. Thus far the first part of the Experiment.

Now the Attrition of the Tube being made in the dark, it was very observable, that when the Glass became warm, a Light would continually follow the Motion of the Hand, backward and forward; and at the same time, if another Hand was held near the Tube, a Light would be seen to break from it with noise, much like that of a Green Leaf in the Fire, for smartness, but nothing so loud: Altho when the Experiment has been very silently made, I have heard several Cracks at 7 or 8 feet distance, or more; if any thing else as well as the Hand was brought near it, a Light would fix upon it, notwithstanding it touched it not, as I have try'd with Gold, Silver, Brass, Ivory, Wood, &c. giving much the same appearance as the Hand. But after the Glass came to be exhausted of its Air, then upon the first Attrition of it, a much larger did ensue; but the quality of giving a Light to a Body approacht near it, seem'd to be quite lost. I conclude this Experiment with taking notice,

tice, That the Light produc'd upon the Attrition of the Exhausted Tube, appear'd wholly within it; and that which was discover'd upon the Affrication of it unexhausted, seem'd to be altogether on its outside.

Postscript.

Since this Account was wrote, I procur'd a solid Tube, about the bigness and of the same Metal with the other; but upon tryal of it find no great Difference in its Operations, in comparison with the other, only its *Effluviu*m seem'd to continue a little longer, but attracts not at a greater distance than the other that I can discover. With this new Tube I made the following Experiment, I took a little Lamp-black, and having dry'd it on a Paper before the Fire, and the Tube being rubb'd till it was warm, then being held near the Lamp black, it was not without pleasure to behold the Brisk Agitation of a number of the Little Bodies, seeming promiscuously Ascending and Descending with great velocity: And it was admirable to see, that Bodies so light *in specie*, which by their own Gravity falling on Paper would make no sensible noise, yet the same return'd with such force from the Tube, that their striking the Paper was very audible.

*A Continuation of the Experiments on the Attrition
of Glass.*

I Procur'd a Glass nearly Cylindrical, of the Length and Diameter about seven Inches each, whose motion was given by a Machine of a new Contrivance ; its Axis lying parallel to the Horizon, which in like Experiments heretofore made, was Diametrically opposite to it. With this new Method, after the Cylinder was exhausted of its Contain'd Air, and the Motion made by the Wheel, it succeeded in respect to the Light produc'd upon the Attrition of it, as in the Experiments formerly mention'd. But when all its Air had return'd into it, and the Attrition and Motion continu'd as at first, it was not a little surprizing to behold from the point of ones Finger to the Glass, a vigorous Light, which began (as has been observ'd) at the Finger first ; and seem'd to Gravitate on it, being sensibly to be felt there, notwithstanding the Moving Body was not toucht with it by near an Inch : This Light seem'd to issue from the Glass with a considerable noise, (not much unlike that of Wheezing, but smarter) and was easily distinguishable from that made by the Operation of the Engine, which was not a small one. Here observing the Vigorousness of the Light, and the Noise that attended the near touching Finger, when the Experiment was made in the Dark, I was willing to satisfy my self whether it would Exhibit any *Phenomenon* by Day light ; accordingly, one day in the Afternoon between 2 and 3 a Clock, in a very light Room, I found that immediately after the Attrition was made on the Moving Glass, and the Finger approacht as before, a pure Purple Light became very visible to extend itself from the Finger to the Cylinder, and was accompany'd with the like premention'd Noise. This Experiment I
have

have repeated several times since at different hours, with the like success: It is always made with Glass unexhausted of its Air. To proceed. As to the Electricity of this Body upon such a Motion and Attrition given it as usual, I do not find that it exceeds in that quality what already I have related in former Experiments. I then took a piece of fine Muslin, which was sow'd to two Wires bent Archwise, that it might surround the upper surface of the Glass, almost at four Inches distance from it: The Muslin I made as ragged (by breaking the Threads of it every where) as I could, (for I find that Small and Light Bodies are most apt to be affected by the *Effluvia* of Glass) then the Motion and Attrition being given, it was pleasing enough to see a Multitude of small Sparks of Light every where on the ends of the torn Threads, which resembled so many little Stars observable in a good Telescope in the *Via Lactea*; and the whole was attended with such a whiteness, by the little Light proceeding from them, as in that part of the Hemisphere taken notice of, by those who behold it with the naked Eye.

After that I tryed, whether the Addition of Heat, by placing a red hot Iron just under the Moving Glass, would advance any thing the appearance of Light, which I found without the Attrition of my Hand would do nothing, and with it no more, that I could discover, than if it had been absent; both, with the Glass exhausted of its Air and without.

Now what farther I have to add, occur'd from observing always that Light Bodies, approach'd near any part of the attricated Cylinder, would seemingly be equally Attracted, or Gravitate; so that I contrived a Semi-circle of Wire, which I could fasten at a constant distance, environing the upper Surface of the Glass at 4 or 5 Inches from it. This Wire had twisted round it some Pack-Thread, whereby I could with Ease hang

the Threads at pretty nearly equal distances; the lower ends of which reaching within less than an Inch of the Glafs, when held approaching the Center of it, but appear'd, when at liberty, as in Figure the 1st.

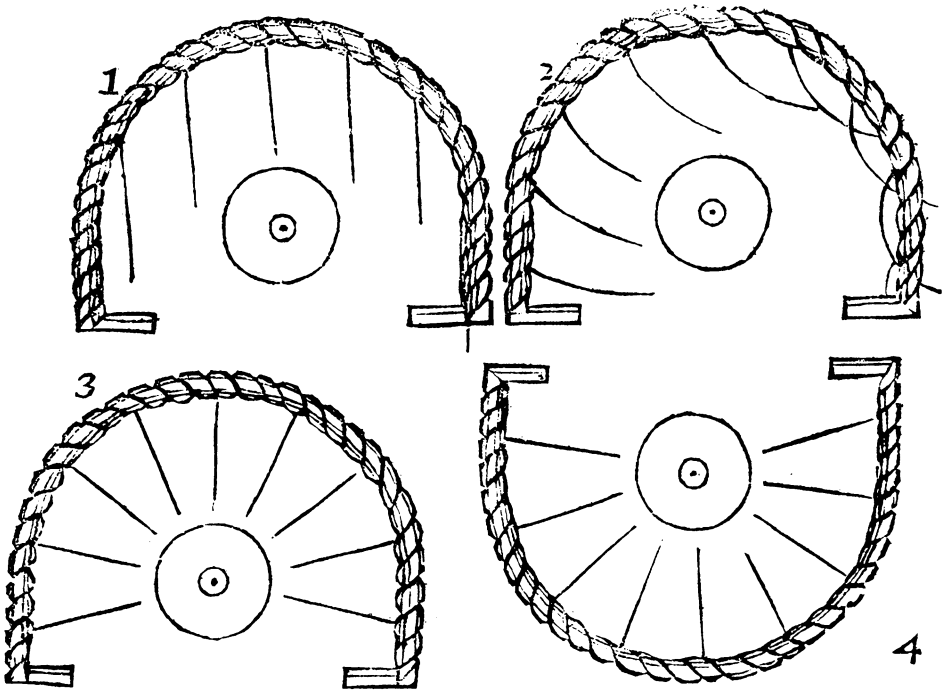

And when the Cylinder was pretty swiftly turn'd about, those Threads would appear by the agitated Air, as in Fig. the 2d. But when on the lower part of the Glafs was applied my hand, the Threads would then represent a Form like Fig. the 3d. And from all parts seem to Gravitate, or were attracted in a direct Line to the Center of the moving Body, suffering no Inconvenience or Disorder of Posture by the Wind occasioned by the Rapidity of the motion; and I could by shifting

ing the Attrition, draw them in a Line towards either end of the Cylinder ; yet still pointing to the Axis of it. And if the Wire with the Threads be revers'd, as I have tryed since, that is, encompassing the under part of the Cylinder, as before the upper, it answer'd exactly the same as the other ; the Threads all pointing to the Axis of it : See Fig. the 4th. I have likewise given a Motion to the same Glass in a perpendicular Posture, by which means I had the opportunity of placing a Hoop-Wire Horizontally, with Threads as before, and left only one small part expos'd for the touch of my Fingers between them ; yet the Threads upon the Motion and Attrition given the Cylinder, elevated themselves from their hanging Posture, making all round an Horizontal Plain, directing their loose ends to the Axis as in the other. Now how far this Experiment may serve to explain the Nature of Electricity, Magnetism, or Gravitation of Bodies, is beyond my Sphere to determine ; but with all Humility submit it to those Learned Gentlemen of this Honourable Society, who have already treated on those Subjects.