

FEB 28 1965



*Technical Note*

*No. 331*

---

**A 100 KW 2-25 Mc/s DISTRIBUTED AMPLIFIER,  
DESIGNED FOR USE WITH 10 KW IONOSPHERIC  
SOUNDERS**

W. B. HARDING, M. W. WOODWARD, AND J. C. CARROLL



---

U. S. DEPARTMENT OF COMMERCE  
NATIONAL BUREAU OF STANDARDS

## THE NATIONAL BUREAU OF STANDARDS

The National Bureau of Standards is a principal focal point in the Federal Government for assuring maximum application of the physical and engineering sciences to the advancement of technology in industry and commerce. Its responsibilities include development and maintenance of the national standards of measurement, and the provisions of means for making measurements consistent with those standards; determination of physical constants and properties of materials; development of methods for testing materials, mechanisms, and structures, and making such tests as may be necessary, particularly for government agencies; cooperation in the establishment of standard practices for incorporation in codes and specifications; advisory service to government agencies on scientific and technical problems; invention and development of devices to serve special needs of the Government; assistance to industry, business, and consumers in the development and acceptance of commercial standards and simplified trade practice recommendations; administration of programs in cooperation with United States business groups and standards organizations for the development of international standards of practice; and maintenance of a clearinghouse for the collection and dissemination of scientific, technical, and engineering information. The scope of the Bureau's activities is suggested in the following listing of its four Institutes and their organizational units.

**Institute for Basic Standards.** Applied Mathematics. Electricity. Metrology. Mechanics. Heat. Atomic Physics. Physical Chemistry. Laboratory Astrophysics.\* Radiation Physics. Radio Standards Laboratory:\* Radio Standards Physics; Radio Standards Engineering. Office of Standard Reference Data.

**Institute for Materials Research.** Analytical Chemistry. Polymers. Metallurgy. Inorganic Materials. Reactor Radiations. Cryogenics.\* Materials Evaluation Laboratory. Office of Standard Reference Materials.

**Institute for Applied Technology.** Building Research. Information Technology. Performance Test Development. Electronic Instrumentation. Textile and Apparel Technology Center. Technical Analysis. Office of Weights and Measures. Office of Engineering Standards. Office of Invention and Innovation. Office of Technical Resources. Clearinghouse for Federal Scientific and Technical Information.\*\*

**Central Radio Propagation Laboratory.\*** Ionospheric Telecommunications. Tropospheric Telecommunications. Space Environment Forecasting. Aeronomy.

---

\* Located at Boulder, Colorado 80301.

\*\* Located at 5285 Port Royal Road, Springfield, Virginia 22171.

# NATIONAL BUREAU OF STANDARDS

## *Technical Note 331*

ISSUED February 15, 1966

A 100 KW 2-25 Mc/s DISTRIBUTED AMPLIFIER,  
DESIGNED FOR USE WITH 10 KW IONOSPHERIC SOUNDERS

W. B. Harding, M. W. Woodward, and J. C. Carroll  
Institute for Telecommunication Sciences and Aeronomy\*  
Environmental Science Services Administration  
Boulder, Colorado

NBS Technical Notes are designed to supplement the Bureau's regular publications program. They provide a means for making available scientific data that are of transient or limited interest. Technical Notes may be listed or referred to in the open literature.

*\*Formerly the Central Radio Propagation Laboratory of the National Bureau of Standards; CRPL was transferred to ESSA in October 1965, but will temporarily use various NBS publication series pending inauguration of their ESSA counterparts.*

---

For sale by the Superintendent of Documents, U.S. Government Printing Office  
Washington D.C. 20402  
Price: 20¢



## Contents

	Page
Abstract	iii
1. Introduction	1
2. Design and Construction	1
2.1 Theoretical Design Considerations	1
2.2 Some Construction Details	5
3. Tests and Results	6
4. Conclusions	7
5. References	8

A 100 kW 2-25 Mc/s Distributed Amplifier,  
Designed for use with 10 kW Ionospheric Sounders  
W. B. Harding, M. W. Woodward, and J. C. Carroll

Abstract

The principles of distributed amplification have been known for many years and have been applied to fast rise time pulse and oscilloscope amplifiers for small-signal applications [Percival, 1935-37; Pettit and McWhorter, 1961]. This paper describes the design, construction, and testing of an r-f distributed amplifier intended for ionospheric sounding and backscatter applications. The amplifier has a power gain of 10 dB and a rated output of 100 kW peak pulse power, over a range of 2 to 25 Mc/s. A feature of this amplifier is the elimination of input and output transformers.

**Key Words:** Amplifier, balanced, bandwidth, ionospheric, power gain, sounder, sweep frequency,

## 1. Introduction

Sweep frequency sounding techniques for ionospheric investigations yield much valuable information. However, for some applications, presently available ionospheric sounding devices are power limited. To increase the power output of a sweep frequency transmitter, a wide-band amplifier is required. Since a distributed amplifier is a reasonably simple device, it was decided to design one for use at fairly high r-f power levels.

## 2. Design and Construction

### 2.1 Theoretical Design Considerations

Distributed amplifier design in the past has been toward unbalanced configurations and in the case of small signal devices has resulted in non-standard unbalanced input and output impedances. High powered designs have appeared using a broadband transformer to convert the output impedance to 50 ohms unbalanced. The use of broadband transformers for high peak pulse powers leads to a high probability of a voltage breakdown within the transformer. Designing a distributed amplifier to match a standard open wire line reduces the probability of destructive voltage breakdowns. This is one of the unique features of this particular amplifier.

For balanced input and output configuration, two side-by-side amplifiers were designed and constructed. Figure 1 is a system block diagram. Figure 2 is the distributed amplifier schematic diagram. Figure 3 is the schematic diagram of the control circuitry.

Very briefly described, a distributed amplifier [Percival, 1935-37; Pettit and McWhorter, 1961] consists of a series of tubes with the grids connected at intervals along a delay line. The plates of

these tubes are connected at corresponding time intervals along another delay line. A signal entering the input travels down the grid line, exciting successive grids, and is finally absorbed by the grid line terminating resistor. Similarly, the signal in the plate line travels down the line, being augmented at each tube until it reaches the output. Backward component voltages are absorbed by the terminating resistor at the reverse end of the plate line. The power dissipated in the line terminating resistors results in a lower efficiency, but this is a price which must be paid for the wide bandwidth obtained. Thus amplification is achieved over a wide frequency range without tuning.

The distributed amplifier under discussion was designed to be driven by the C-3 ionospheric sounder. The C-3 equipment has a nominal peak pulse power capability of 10 kW and a sweep frequency range of 1 to 25 Mc/s. Consideration was given to the desire to extend the frequency range of the present equipment to 60 Mc/s, and a cut-off frequency of 70 Mc/s was inserted into the design requirements for the subject amplifier. Seventy Mc/s was used in order to maintain as much output as possible thru 60 Mc/s; however, lack of a suitable driving power source has prevented testing above 25 Mc/s.

In conventional broadband amplifiers, if the tubes are paralleled to obtain the necessary output power, the tube capacitances add, thus lowering the input impedance excessively. On the other hand, the distributed amplifier provides a method of effectively paralleling tubes so that the transconductances add while the input and output capacitances remain separate and are used as parts of the delay line constants. Therefore, the input and output capacitances of the tubes selected are the first design consideration.

The nominal output impedance of the C-3 ionospheric sounder is 600 ohms, balanced, but tests were conducted which indicated that



the C-3 could be operated into a balanced load of 300 ohms. A design value of 300 ohms input impedance permitted use of readily available tubes. The output impedance selected was 600 ohms, balanced.

The tube most nearly approaching the requirements for this project was the 4-1000A. The input capacitance of this tube varies from 23.8 to 32.4 pf. Tubes are selected to have as nearly as is possible the same input capacitance. This value limits the input impedance to 150 ohms (for one side) or lower for a cut-off frequency of 70 Mc/s. The output capacitance of the 4-1000A will vary from 6.8 to 9.4 pf. This value is small enough to allow for trimming of the plate line, if necessary, with small values of capacitance to equalize the delay in the input and output lines.

The following design values, assuming an unbalanced half of the circuit, are fixed:

$$\begin{aligned}Z_{in} & \text{ (input impedance) } = 150 \text{ ohms} \\Z_{out} & \text{ (output impedance) } = 300 \text{ ohms} \\f_c & \text{ (cut-off frequency) } = 7 \times 10^7 \text{ c/s.}\end{aligned}$$

The design values to be calculated are as follows:

$$\begin{aligned}C_g & = \text{grid line capacitance per section} \\C_p & = \text{plate line capacitance per section} \\L_g & = \text{grid line inductance per section} \\L_p & = \text{plate line inductance per section.}\end{aligned}$$

The design equations were obtained from references on small-signal distributed amplifiers [Ginzton, Hewlett, Jasberg, and Noe, 1948; Rudenberg and Kennedy, 1949; Horton, Jasberg, and Noe, 1950; Cormack, 1952; Stockman, 1956].

The values of  $C_g$  and  $C_p$  were determined by the following equation:

$$C = \frac{1}{\pi f_c Z}$$

The values of  $L_g$  and  $L_p$  were determined by the following equation:

$$L = Z^2 C.$$

The reverse termination for the grid and plate lines consists of non-inductive resistors equal to the line impedance.

The plate and grid lines of each unbalanced half of the amplifier are essentially low pass filter sections of the constant K type. The delay in the plate and grid lines must be precisely the same in order for the signal in the plate line to be reinforced at the plates of successive tubes. When this condition exists, it results in gain from each tube and a relative phase shift thru each tube which will vary from zero at zero frequency to  $180^\circ$  at the cut-off frequency. Low frequency response of the amplifier is limited by the necessity for d-c voltage blocking. The phase relationship at the output terminals of the amplifier is dependent upon the phase relationship at the input terminals. In considering the signal at the input terminals, it must be realized that an amplifier of this type will amplify all of the signals present within its bandwidth. The amplifier is designed to operate as a linear device and is operated in class  $AB_1$  to minimize harmonic generation.

The filament of the 4-1000A is of the thoriated tungsten type. With thoriated tungsten filaments operating at the rated voltage in these tubes, the available emission is approximately 80 milliamperes per watt of filament power. By raising the filament voltage 10%, this figure can be approximately doubled. This is recommended by the

tube manufacturer when using these tubes in pulse service. Tests were made with normal and normal plus 10% filament voltages. With normal voltage, the amplifier was capable of a power output of 60 kW. By increasing the filament voltages 10%, 100 kW was easily obtained. The filaments of the subject distributed amplifier are operated at 10% above nominal voltage.

## 2.2 Some Construction Details

The distributed amplifier is constructed with the grid and plate lines mounted vertically in a cabinet. The tubes, two to a chassis, are placed between the input and output lines and at the proper intervals along the lines. The cathode of each tube is metered from the front panel with an adjustable range meter to compensate for different duty factors. The blowers, one for each tube, are mounted on the front panels at the level of each chassis. Filament transformers for each tube are mounted on each chassis and controlled by means of a variable transformer in the bottom of the cabinet. One transformer is continuously metered as a means of adjusting the filament voltage. Each filament transformer secondary can be measured at the terminal strips on the side of each chassis. All d-c power supplies are external, and all voltages are adjustable. Voltages and currents are metered on the power supply panels. Bias and air interlocks are built into the amplifier cabinet. All voltages are present on the tube elements at all times. Figures 4, 5a and 5b show views of the complete distributed amplifier and power supplies.

The amplifier will operate with a plate potential of 15 kV. However, for dependable long term operation, this should be reduced to 12 kV, as flash-over will occur at times between the plate caps and the next chassis when operating with the higher voltage.

The plexiglass forms on which the plate inductors are wound are 1 inch in diameter and extend a minimum of 4 inches beyond the end of each coil. Initially these sections were fastened to a plexiglass support with 1/4 inch brass screws. Large corona discharge appeared at these screws when operation was attempted, and they were replaced with nylon screws. No metal should be used in the plate line supports, even though they are floating with reference to ground.

The present packaging, while nearly ideal mechanically and electrically, presents some shielding problems. The sides of each compartment must be removable in order to replace tubes. This requires a rigid frame with r-f gaskets and some type of speed fastener. It is recommended that, in future amplifiers, consideration be given to the mounting of all eight tubes on one large chassis in a horizontal plane. The power supplies could be mounted beneath the chassis, resulting in a self-contained unit, and any tube could be replaced from one opening.

### 3. Tests and Results

Although the amplifier was designed for operation to 60 Mc/s, it has been tested thus far only to 25 Mc/s because of lack of adequate drive for the higher range.

The distributed amplifier has been tested and is presently being used within the limits of the C-3 driver. No attempt has been made to select tubes or to trim the plate lines. There has been no indication of instability with  $AB_1$  operation. Figure 6 is the response with reference to 100 kW over the tested frequency range. The measurements were made with open wire line into a load of 600 ohms, constructed of eight 100 watt, 300 ohm, non-inductive resistors connected in series-parallel. Figure 7 shows the measured phase shift of the distributed amplifier.

These measurements were made at low power by comparing the signal at the input terminals with the signal at the output terminals with an oscilloscope.

Figures 8a and 8b show sweep frequency backscatter records obtained using (a) C-3 only and (b) C-3 driving the distributed amplifier. These records were made on February 25, 1963, using a rotatable log periodic antenna directed toward  $150^{\circ}$  E of N. The pulse repetition rate is 12.5 pps and the pulse length is 250  $\mu$ s. Each record is a complete sweep from 7 Mc/s to 25 Mc/s. The vertical markers indicate frequency and are spaced at 1 Mc/s. The horizontal markers indicate range and are spaced at 500 km.

Improvement in the ionograms as a result of adding the distributed amplifier is evidenced by the filling-in of the F layer signature, and the appearance of E layer returns not seen in the ionogram using the C-3 alone.

#### 4. Conclusions

The results of this project confirm that distributed amplification is useful for sweep frequency applications. It has also demonstrated the possibility of designing high powered distributed amplifiers without the use of critical input and output transformers. There are presently available tubes with which it seems practical to attain an additional 10 dB of power gain, although the costs would have to be balanced against the value of the possible increase in information achieved with such a system.

#### Acknowledgment

The authors wish to express their thanks to Dr. W. V. Tilston for his interest in this project and his suggestions in the preparation of this report.

## 5. References

- Cormack, A. (April 1952), Distributed amplification, *Electronic Engineering*, pp. 144-147.
- Ginzton, E. L., W. B. Hewlett, J. H. Jasberg, and J. D. Noe, (August 1948), Distributed amplification, *Proc. IRE* 36, No. 8, pp. 956-969.
- Horton, W. H., J. H. Jasberg, and J. D. Noe (July 1950), Distributed amplifiers; practical considerations and experimental results, *Proc. IRE* 38, No. 7, pp. 748-753.
- Percival, W. S. (1935-37), British Patent 460562.
- Pettit, J. M., and M. M. McWhorter (1961), *Electronic amplifier circuits*, McGraw Hill, New York.
- Rudenberg, H. G., and F. Kennedy (December 1949), 200 Mc traveling-wave chain amplifier, *Electronics*, pp. 106-109.
- Stockman, H. (1956), *Introduction to distributed amplification*, published by SER Company, Waltham, Massachusetts.

BLOCK DIAGRAM OF 100 kw DISTRIBUTED AMPLIFIER

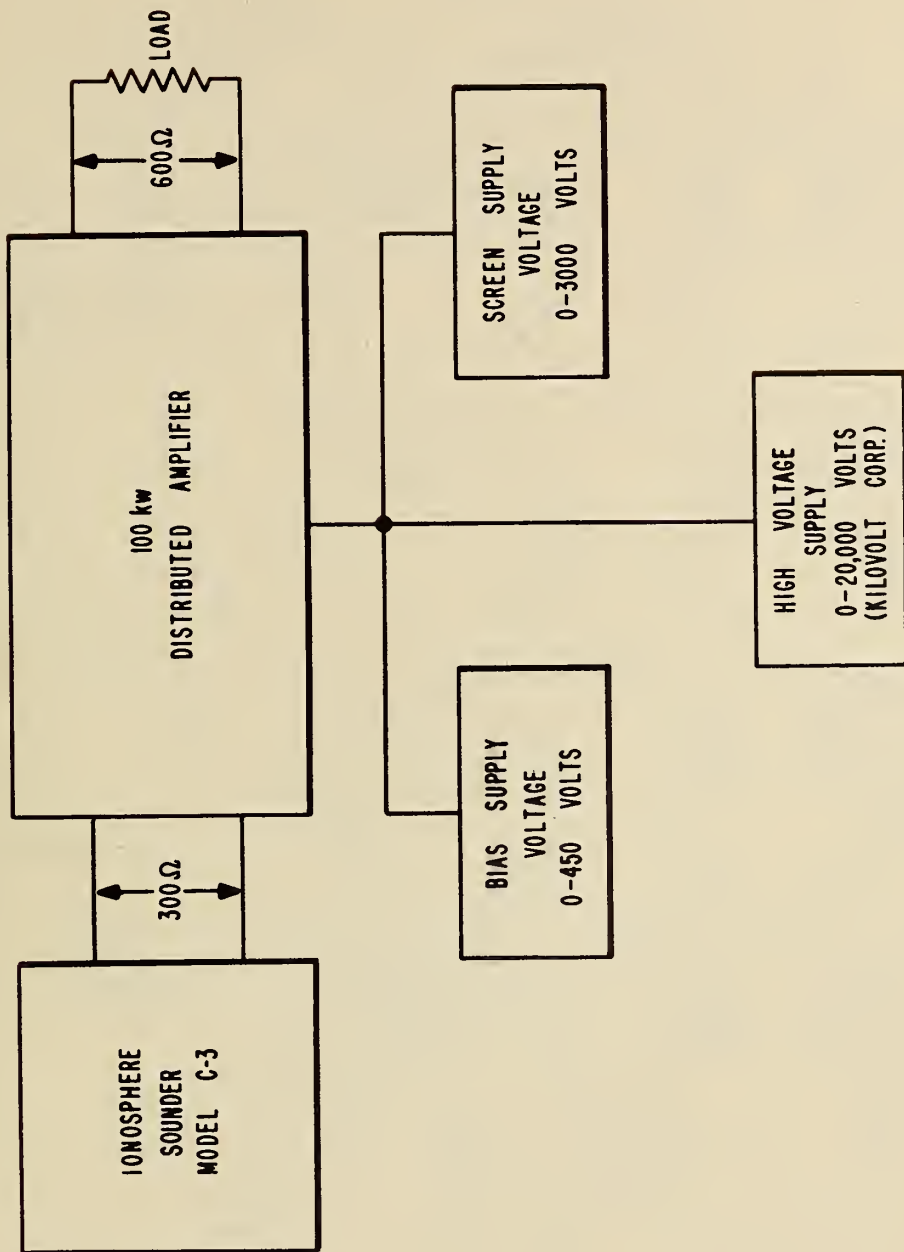

Figure 1. System block diagram

# CIRCUIT DIAGRAM OF 100 kw DISTRIBUTED AMPLIFIER

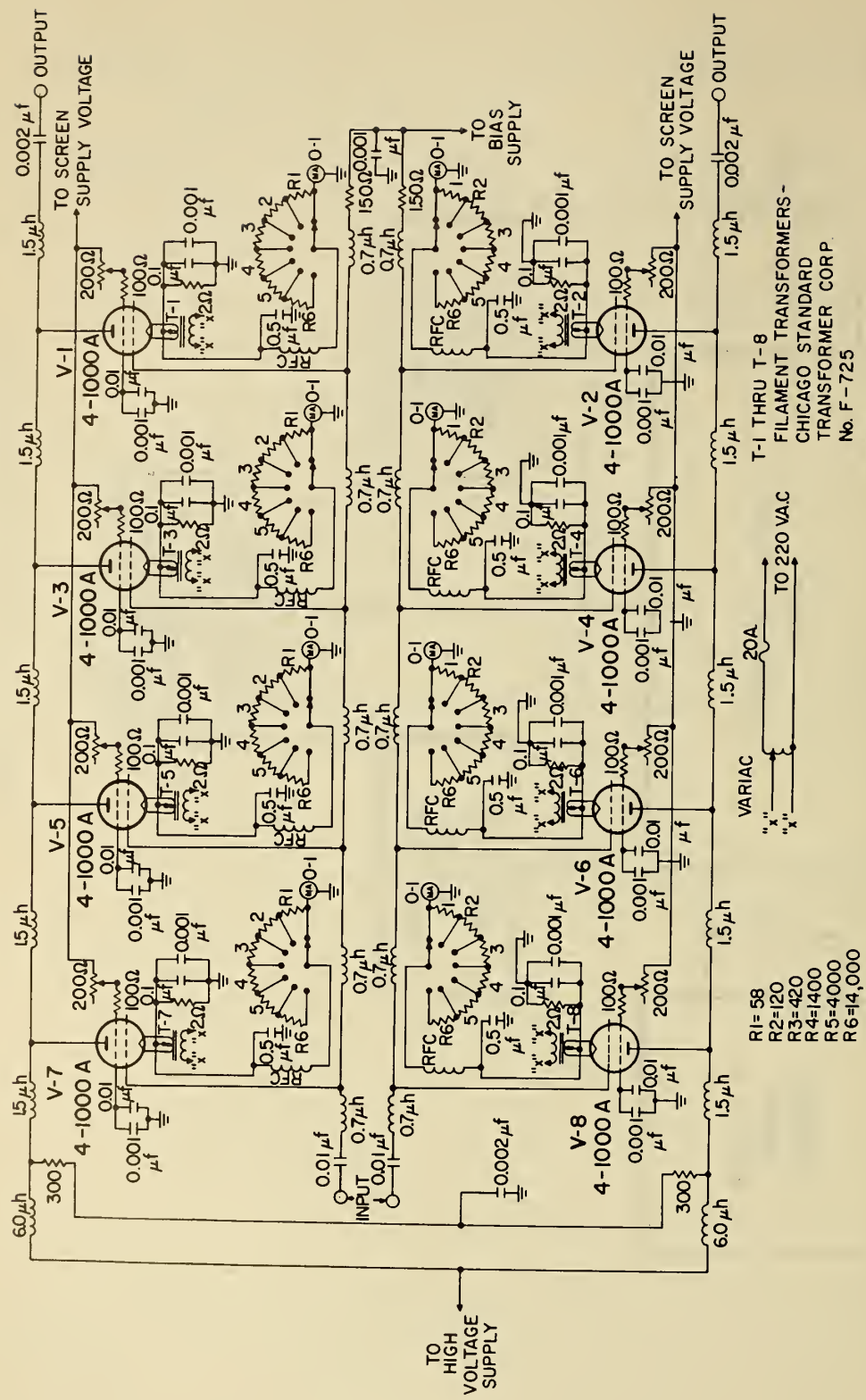

Figure 2. Distributed amplifier schematic diagram



CONTROL CIRCUIT

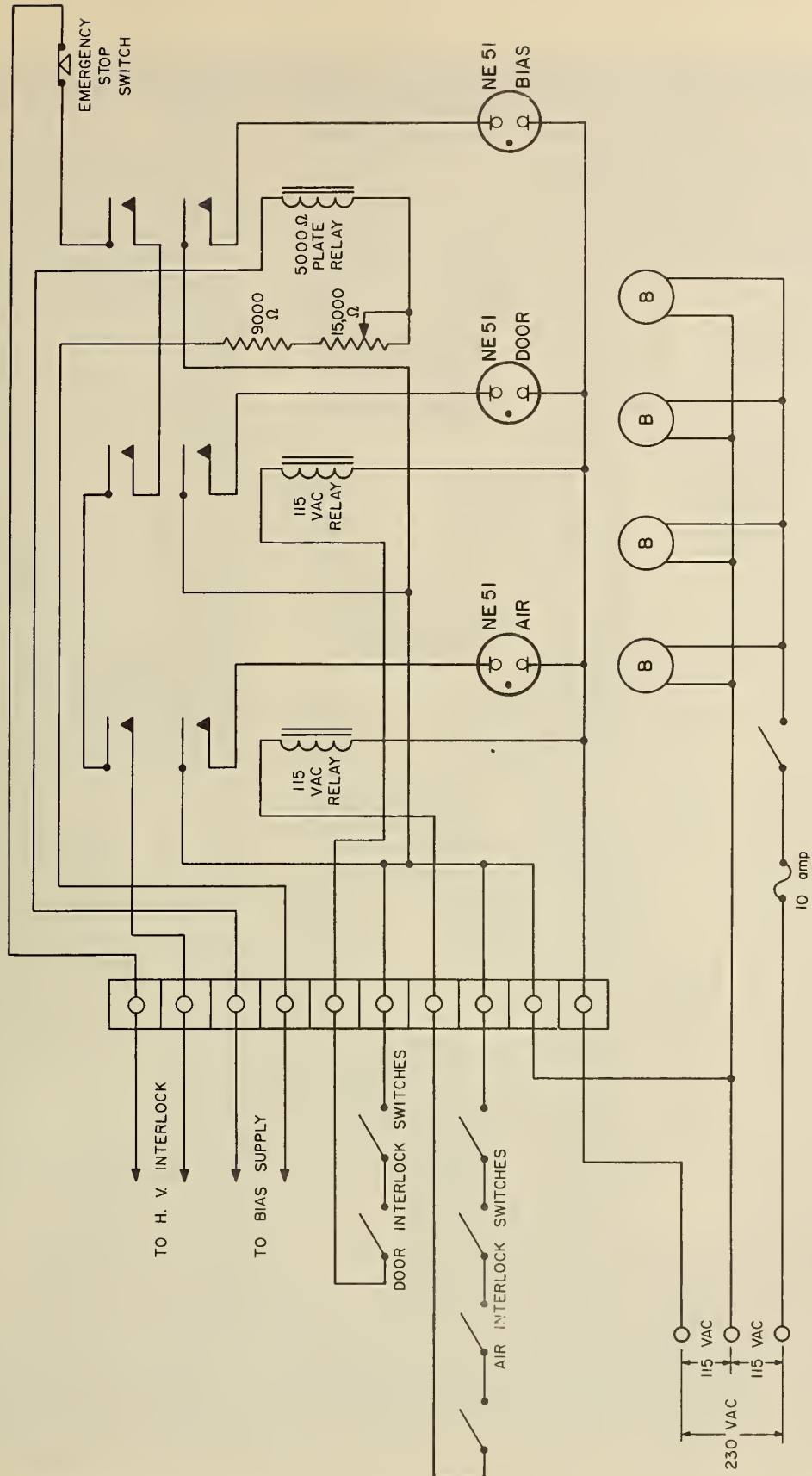

Figure 3. Control circuit schematic diagram

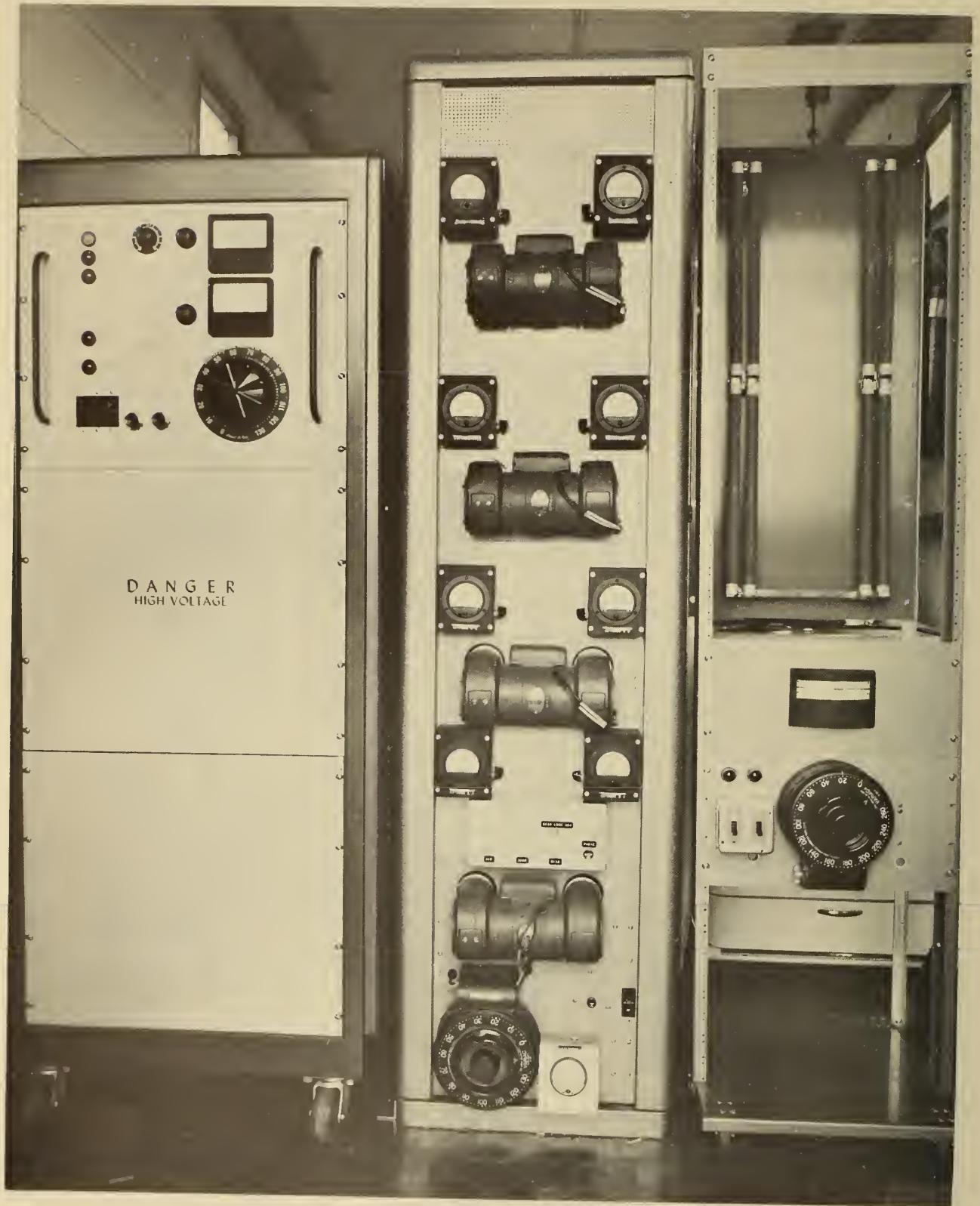

Figure 4. Front view of distributed amplifier, power supply and dummy load

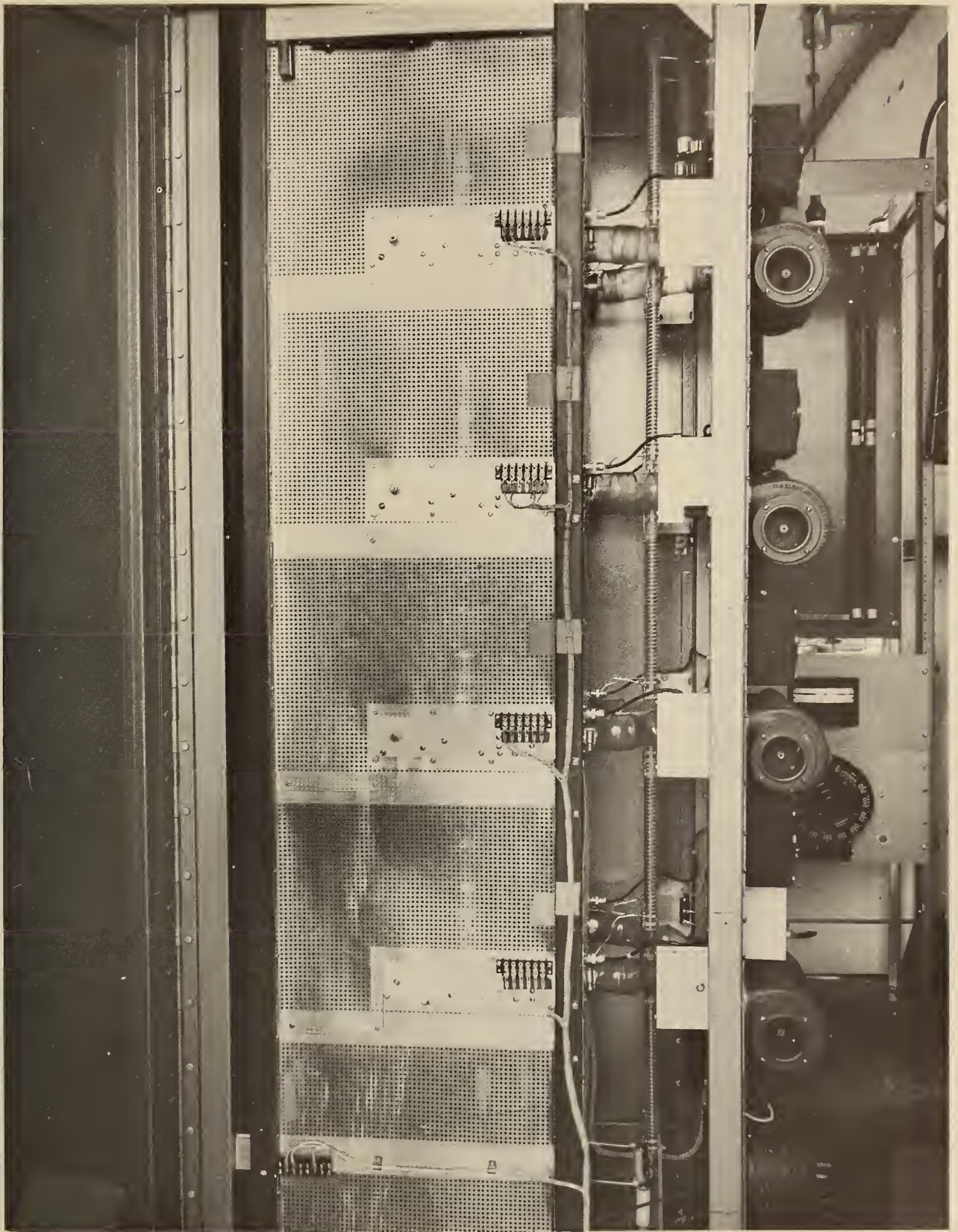

Figure 5a. Side view of distributed amplifier, shields in place

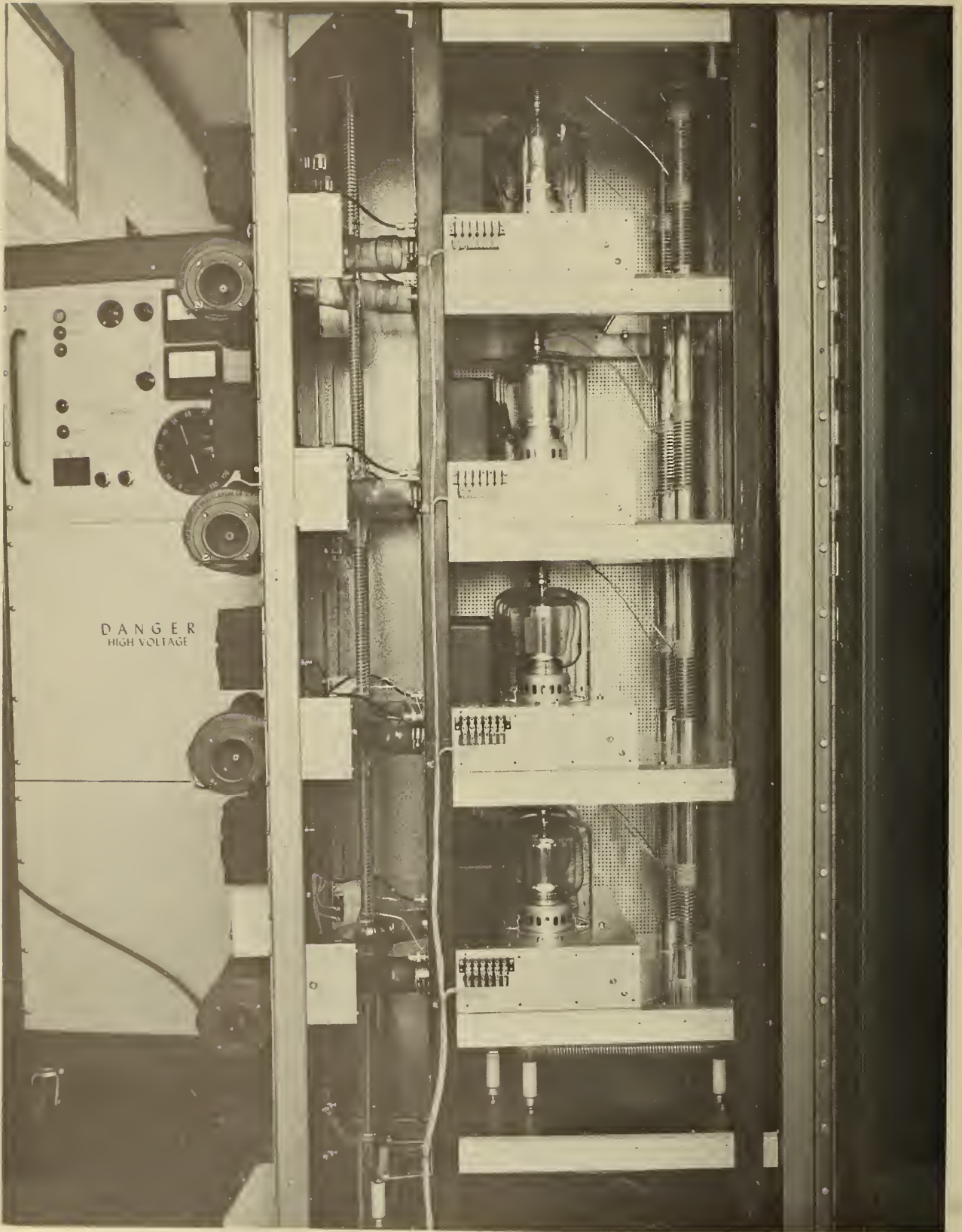

Figure 5b. Side view of distributed amplifier, shields removed

AMPLIFIER RESPONSE WITH REFERENCE TO 100kW

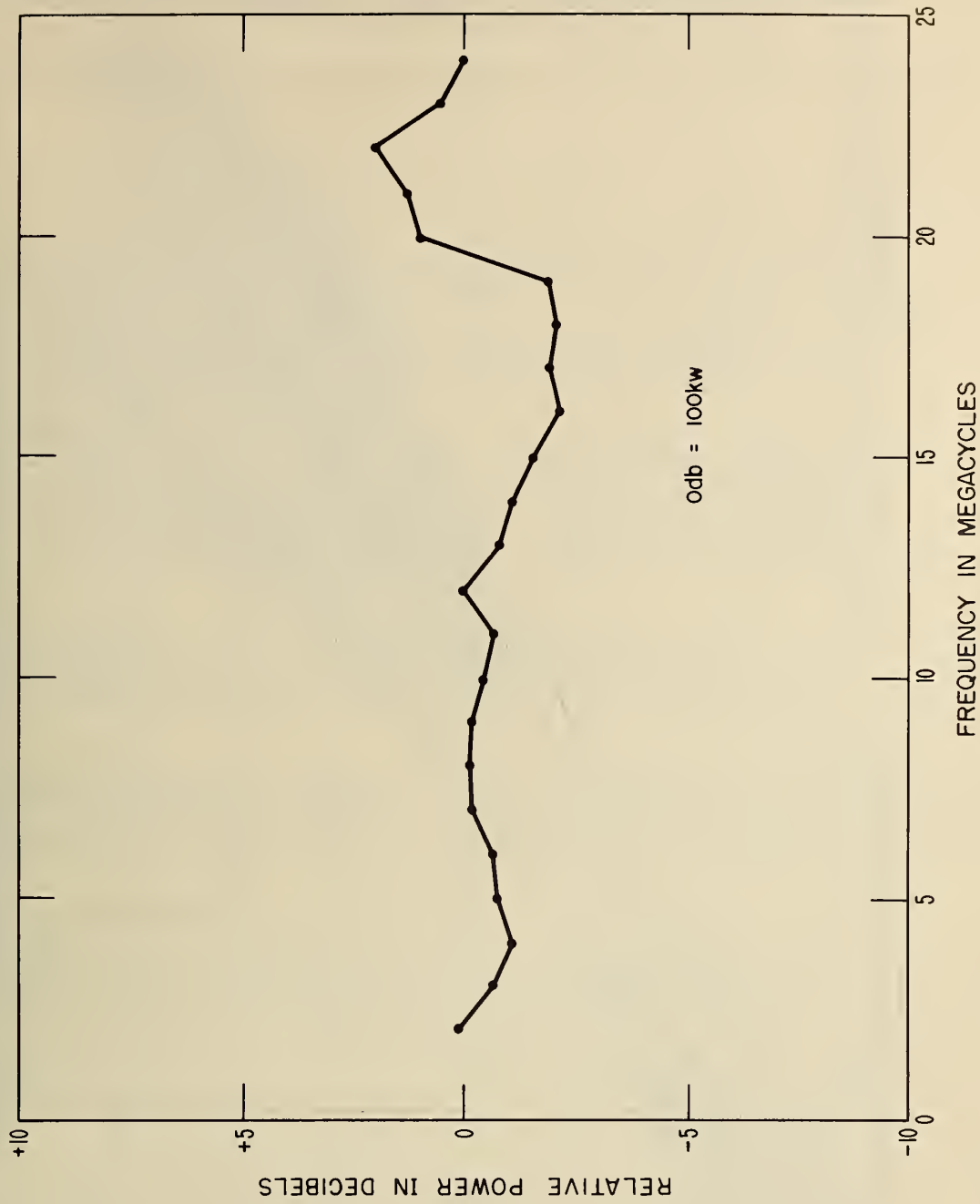

Figure 6. Amplifier response with reference to 100 kW

PHASE SHIFT OF 4-1000A D.A. INPUT TO OUTPUT

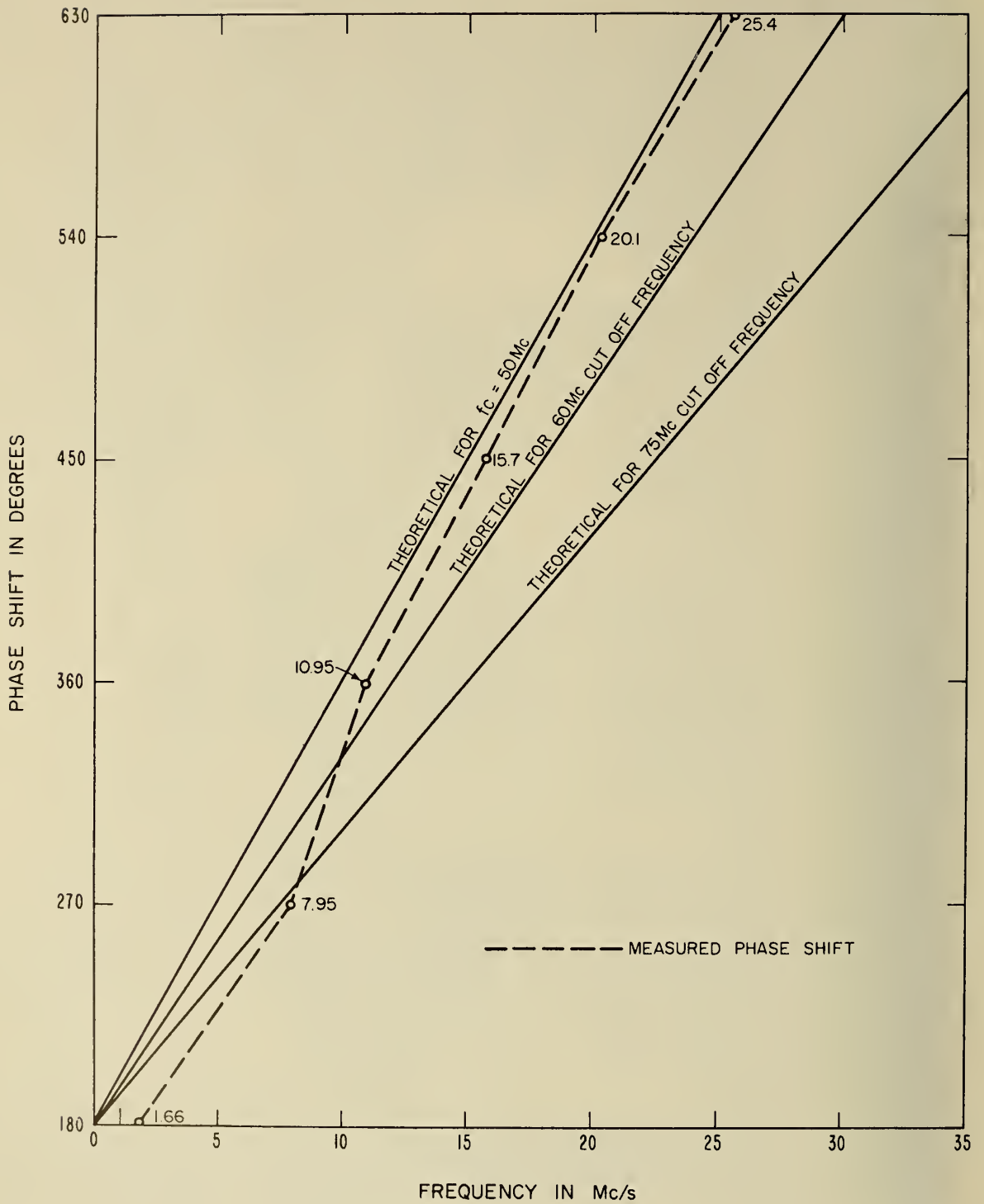

Figure 7. Phase shift of distributed amplifier

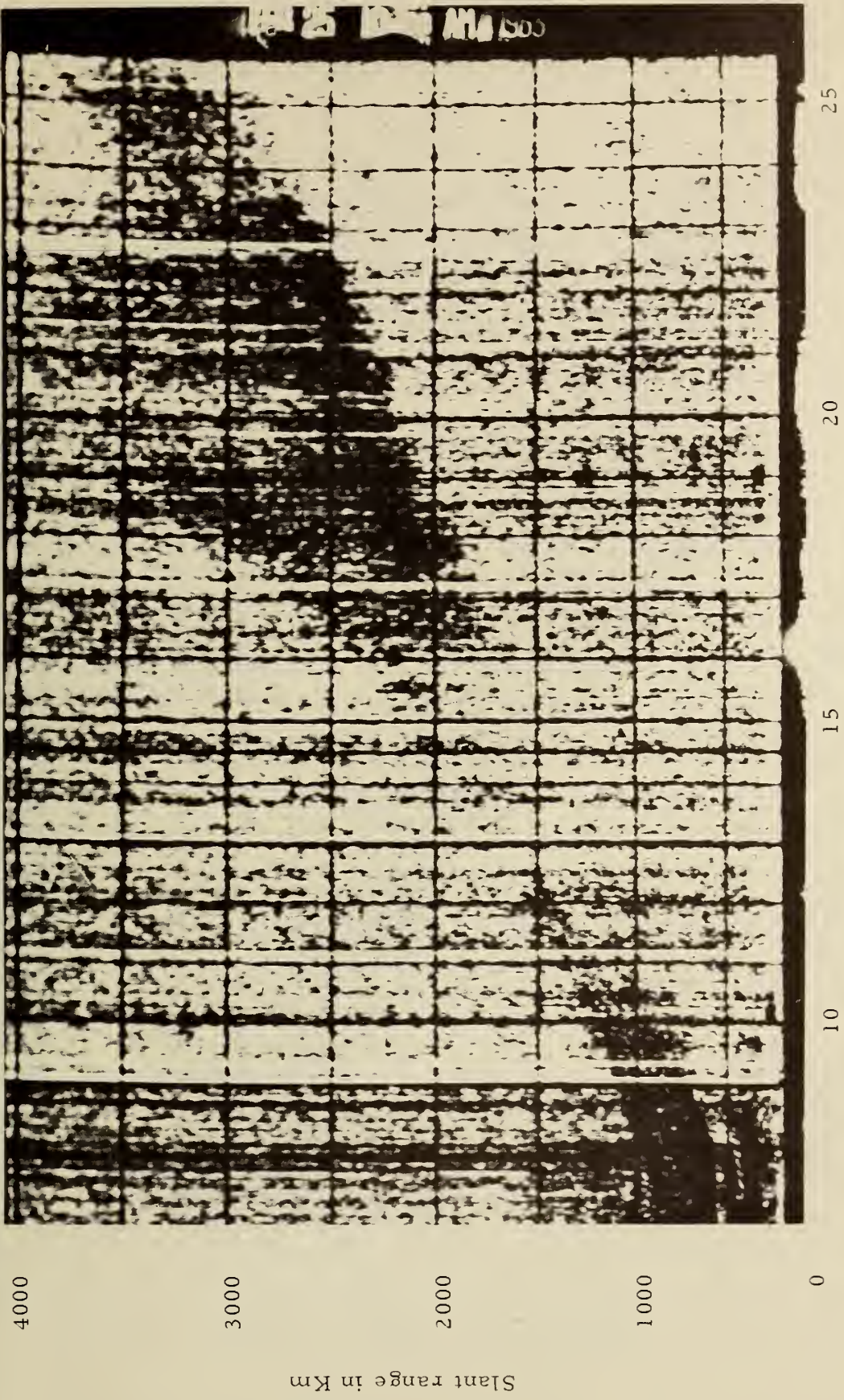

Figure 8a. C-3 sweep frequency backscatter record



Frequency in Mc/s

Figure 8b. Sweep frequency backscatter record using distributed amplifier with C-3





U.S. DEPARTMENT OF COMMERCE  
WASHINGTON, D.C. 20230

POSTAGE AND FEES PAID  
U.S. DEPARTMENT OF COMMERCE

---

OFFICIAL BUSINESS

---