













# Journal of the Royal Microscopical Society

CONTAINING ITS TRANSACTIONS AND PROCEEDINGS

AND

A SUMMARY OF CURRENT RESEARCHES RELATING TO  
ZOOLOGY AND BOTANY  
(principally Invertebrata and Cryptogamia)  
MICROSCOPY, &c.

EDITED BY

R. G. HEBB, M.A. M.D. F.R.C.P.

*Physician Pathologist to Westminster Hospital*

WITH THE ASSISTANCE OF THE PUBLICATION COMMITTEE AND

J. ARTHUR THOMSON, M.A. F.R.S.E.

*Regius Professor of Natural History in the University of Aberdeen*

A. N. DISNEY, M.A. B.Sc.

FELLOWS OF THE SOCIETY

AND

A. B. RENDLE, M.A. D.Sc. F.L.S.

J. J. DOUGLAS, M.D. F.R.C.P.E.

*Assistant in Botany, British Museum*

Minimis partibus, per totum Naturæ campum, certitudo omnis innititur  
quas qui fugit pariter Naturam fugit.—*Linneus.*

FOR THE YEAR  
1903



TO BE OBTAINED AT THE SOCIETY'S ROOMS,  
20 HANOVER SQUARE, LONDON, W.  
OF MESSRS. WILLIAMS & NORGATE, 14 HENRIETTA STREET, LONDON, W.C.  
AND OF MESSRS. DULAU & CO., 37 SOHO SQUARE, LONDON, W.

248



THE  
**Royal Microscopical Society.**

(Established in 1839. Incorporated by Royal Charter in 1866.)

**The Society** was established for the promotion of Microscopical and Biological Science by the communication, discussion, and publication of observations and discoveries relating to (1) improvements in the construction and mode of application of the Microscope, or (2) Biological or other subjects of Microscopical Research.

It consists of Ordinary, Honorary, and Ex-officio Fellows of either sex.

**Ordinary Fellows** are elected on a Certificate of Recommendation signed by three Ordinary Fellows, setting forth the names, residence, and description of the Candidate, of whom the first proposer must have personal knowledge. The certificate is read at two General Meetings, and the Candidate balloted for at the second Meeting.

The Admission Fee is 2*l.* 2*s.*, paid at the time of election, and the Annual Subscription is 2*l.* 2*s.*, payable on election, and subsequently in advance on 1st January in each year, but future payments may be compounded for at any time for 3*l.* 10*s.* Fellows elected at a meeting subsequent to that in February are only called upon for a proportionate part of the first year's subscription. The annual Subscription of Fellows permanently residing abroad is 1*l.* 11*s.* 6*d.* or a reduction of one-fourth.

**Honorary Fellows** (limited to 50), consisting of persons eminent in Microscopical or Biological Science, are elected on the recommendation of five Ordinary Fellows and the approval of the Council.

**Ex-officio Fellows** (limited to 100), consisting of the Presidents for the time being of any Societies having objects in whole or in part similar to those of the Society, are elected on the recommendation of ten Ordinary Fellows and the approval of the Council.

**The Council**, in whom the management of the property and affairs of the Society is vested, is elected annually, and is composed of the President, four Vice-Presidents, Treasurer, two Secretaries, and twelve other Ordinary Fellows.

**The Meetings** are held on the third Wednesday in each month, from October to June, at 20 Hanover Square, W. (commencing at 8 P.M.). Visitors are admitted by the introduction of Fellows.

**The Journal**, containing the Transactions and Proceedings of the Society, and a Summary of Current Researches relating to Zoology and Botany (principally Invertebrata and Cryptogamia), Microscopy, &c., is published bi-monthly, and is forwarded post-free to all Ordinary and Ex-officio Fellows residing in countries within the Postal Union.

**The Library**, with the Instruments, Apparatus, and Cabinet of Objects, is open for the use of Fellows daily (except Saturdays), from 10 A.M. to 5 P.M. It is closed for four weeks during August and September.

*Forms of proposal for Fellowship, and any further information, may be obtained by application to the Secretaries, or Assistant-Secretary, at the Library of the Society, 20 Hanover Square, W.*

## Patron

HIS MAJESTY THE KING.

## Past-Presidents.

	Elected
*SIR RICHARD OWEN, K.C.B., D.C.L., M.D., LL.D., F.R.S.	1840-1
*JOHN LINDLEY, Ph.D., F.R.S. ....	1842-3
*THOMAS BELL, F.R.S. ....	1844-5
*JAMES SCOTT BOWERBANK, LL.D., F.R.S. ....	1846-7
*GEORGE BUSK, F.R.S. ....	1848-9
*ARTHUR FARRE, M.D., F.R.S. ....	1850-1
*GEORGE JACKSON, M.R.C.S. ....	1852-3
*WILLIAM BENJAMIN CARPENTER, C.B., M.D., LL.D., F.R.S..	1854-5
*GEORGE SHADBOLT ....	1856-7
*EDWIN LANKESTER, M.D., LL.D., F.R.S. ....	1858-9
*JOHN THOMAS QUEKETT, F.R.S. ....	1860
*ROBERT JAMES FARRANTS, F.R.C.S. ....	1861-2
*CHARLES BROOKE, M.A., F.R.S. ....	1863-4
*JAMES GLAISHER, F.R.S. ....	1865-6-7-8
*REV. JOSEPH BANCROFT READE, M.A., F.R.S. ....	1869-70
*WILLIAM KITCHEN PARKER, F.R.S. ....	1871-2
*CHARLES BROOKE, M.A., F.R.S. ....	1873-4
HENRY CLIFTON SORBY, LL.D., F.R.S. ....	1875-6-7
*HENRY JAMES SLACK, F.G.S. ....	1878
LIONEL S. BEALE, M.B., F.R.C.P., F.R.S. ....	1879-80
*PETER MARTIN DUNCAN, M.B., F.R.S. ....	1881-2-3
REV. WILLIAM HY. DALLINGER, M.A., LL.D., F.R.S.	1884-5-6-7
*CHARLES THOS. HUDSON, M.A., LL.D. (Cantab.), F.R.S.	1888-9-90
ROBERT BRAITHWAITE, M.D., M.R.C.S. ....	1891-2
ALBERT D. MICHAEL, F.L.S. ....	1893-4-5-6
EDWARD MILLES NELSON. ....	1897-8-9
WILLIAM CARRUTHERS, F.R.S., F.L.S., F.G.S. ....	1900-1

\* Deceased.

# COUNCIL.

ELECTED 21ST JANUARY, 1903.

## President.

HENRY WOODWARD, Esq., LL.D., F.R.S., F.G.S., F.Z.S.

## Vice-Presidents.

\*WILLIAM CARRUTHERS, Esq., F.R.S., F.L.S., F.G.S.

\*GEORGE C. KAROP, Esq., M.R.C.S.

\*A. D. MICHAEL, Esq., F.L.S.

\*E. M. NELSON, Esq.

## Treasurer.

J. J. VEZEY, Esq.

## Secretaries.

REV. W. H. DALLINGER, LL.D., D.Sc., D.C.L., F.R.S.

R. G. HEBB, Esq., M.A., M.D., F.R.C.P.

## Ordinary Members of Council.

JAS. MASON ALLEN, Esq.

WYNNE E. BAXTER, Esq., J.P., F.G.S., F.R.G.S.

CONRAD BECK, Esq.

\*ROBERT BRAITHWAITE, Esq., M.D., M.R.C.S., F.L.S.

REV. EDMUND CARR, M.A., F.R.Met.S.

\*A. N. DISNEY, Esq., M.A. B.Sc.

JAS. WM. GIFFORD, Esq.

THE RIGHT HON. SIR FORD NORTH, P.C., F.R.S.

HENRY GEORGE PLIMMER, Esq., M.R.C.S., F.L.S.

THOMAS H. POWELL, Esq.

PERCY E. RADLEY, Esq.

\*CHARLES F. ROUSSELET, Esq.

## Librarian.

PERCY E. RADLEY, Esq.

## Curator.

CHARLES F. ROUSSELET, Esq.

## Assistant Secretary.

MR. F. A. PARSONS.

\* Members of the Publication Committee.



# CONTENTS.

## TRANSACTIONS OF THE SOCIETY.

	PAGE.
I.—The Rotatorian Genus <i>Diaschiza</i> : A Monographic Study, with Description of a New Species. By F. R. Dixon-Nuttall, F.R.M.S., and Rev. R. Freeman, M.A. (Plates I, to IV.) .. .. .	1, 129
II.—An Arrangement for Obtaining Monochromatic Light with the Mixed Jet. By Edmund J. Spitta, F.R.A.S., &c. (Fig. 1) .. .. .	15
III.—The President's Address: Some Ideas on Life. By Henry Woodward, LL.D. F.R.S. (Figs. 34-36) .. .. .	142
IV.—Report on the Recent Foraminifera of the Malay Archipelago collected by Mr. A. Durrand, F.R.M.S.—Part XIV. By Fortescue William Millett, F.R.M.S. (Plate V.) .. .. .	253
V.—A New Method of Using the Electric Arc in Photomicrography. By E. B. Stringer, B.A. F.R.M.S. .. .. .	276
VI.—The Helmholtz Theory of the Microscope. By J. W. Gordon. (Plate VI.) (Figs. 76-116) .. .. .	381
VII.—On the Theory of Optical Images, with Special Reference to the Microscope. By Lord Rayleigh. (Figs. 117-120) .. .. .	447
VIII.—On the Theory of Optical Images, with Special Reference to the Microscope. (Supplementary Paper.) By Lord Rayleigh .. .. .	474
IX.—On the Rendering Visible of Ultra-Microscopic Particles and of Ultra-Microscopic Bacteria. By H. Siedentopf, Ph.D. .. .. .	573
X.—A Micrometric Correction for Minute Objects. By Edward M. Nelson. (Figs. 139-142) .. .. .	579
XI.—On the "Lag" in Microscopic Vision—(continued). By Edward M. Nelson .. .. .	583
XII.—Report on the Recent Foraminifera of the Malay Archipelago collected by Mr. A. Durrand, F.R.M.S.—Part XV. By Fortescue William Millett, F.R.M.S. (Plate VII.) .. .. .	685

## NOTES.

	PAGE
A Two-speed Fine Adjustment. By Edward M. Nelson. (Fig. 2) .. .. .	19
An Old Non-Achromatic Simple Microscope. By Edward M. Nelson. (Figs. 143-148) .. .. .	587
An Early Compound Microscope with a Mirror attached to its Limb. By Edward M. Nelson. (Fig. 149) .. .. .	590
An Improved Horseshoe Stage. By Edward M. Nelson. (Figs. 150 and 151) ..	591

## OBITUARY.

James Glaisher, F.R.S. F.R.A.S. F.R. Met. S. F.R.M.S. .. .. .	158
Rev. Thomas Wiltshire, M.A. D.Sc. F.L.S. F.G.S. F.R.A.S. F.R.M.S. .. .. .	159

## SUMMARY OF CURRENT RESEARCHES

RELATING TO ZOOLOGY AND BOTANY (PRINCIPALLY INVERTEBRATA AND CRYPTOGAMIA), MICROSCOPY, &C., INCLUDING ORIGINAL COMMUNICATIONS FROM FELLOWS AND OTHERS.\* 21, 160, 281, 483, 593, 705

## ZOOLOGY.

## VERTEBRATA.

## a. Embryology.

DELAGÉ, YVES— <i>Carbonic Acid as a Provocative of Artificial Parthenogenesis</i> ..	21
“ “ <i>Agency of Carbon Dioxide in Inducing Artificial Parthenogenesis</i> ..	21
VIGUIER, C.— <i>Artificial Parthenogenesis</i> .. .. .	22
CHARRIN, A., & OTHERS— <i>Reappearance in Offspring of Lesions Artificially induced in the Mother</i> .. .. .	22
WINIWARTER, HANS VON— <i>Note on Oogenesis in Mammals</i> .. .. .	22
BÜHLER, A.— <i>Retrogressive Changes in Ovarian Follicle of Amphibians</i> .. .. .	22
BEARD, JOHN— <i>Germ-Cells and Germinal Continuity</i> .. .. .	22
LOISEL, G.— <i>Spermatogenesis in Sparrow</i> .. .. .	23
MEVES, F. R.— <i>Dimorphism of Spermatozoa</i> .. .. .	23
KORFF, K. VON— <i>Spermatogenesis in Phalangista vulpina</i> .. .. .	24
TORREY, H. B.— <i>Prepotency in Polydactylous Cats</i> .. .. .	24
DEAN, BASHFORD— <i>Biometric Evidence bearing on Theory of Limb-Origin</i> .. ..	24
SIMON, L.— <i>Notes on Development and Structure of Bradypus</i> .. .. .	24
RABL, CARL— <i>Development of External Body-Form</i> .. .. .	24
THILO, O.— <i>Skeletal Changes in Flat-Fishes in the Course of Development</i> .. ..	25
MOSEK, FANNY— <i>Development of Vertebrate Lung</i> .. .. .	25
EIGENMANN, CARL H.— <i>Solution of the Eel Question</i> .. .. .	25
HERTWIG, O.— <i>Treatise on Comparative and Experimental Embryology of Vertebrates</i>	160
ČERMAK, N.— <i>Fertilisation in Salmon</i> .. .. .	160
WEDEKIND, W.— <i>Vestigial Function</i> .. .. .	160
HOUSSAY, F.— <i>Organic Sexual Dimorphism in Fowls</i> .. .. .	160
WEISMANN, AUGUST— <i>Regeneration in Newts</i> .. .. .	161
WEBER, A.— <i>Torsion of Bird-Embryo</i> .. .. .	161

\* In order to make the Contents complete, the papers printed in the ‘Transactions’ and the Notes printed in the ‘Proceedings’ are included here.

	PAGE
SCHMITT, F.— <i>Gastrulation of Double-Development in Trout</i> .. .. .	161
PELLEGRIN, J.— <i>Curvature of the Spine in Fishes</i> .. .. .	161
HÄCKER, V.— <i>Parental and Grand-parental Components of the Nucleus</i> .. .. .	281
LUBOSCH, W.— <i>Maturation in Newt's Ova and in General</i> .. .. .	281
ROULE, L.— <i>Hermaphroditism in Fishes</i> .. .. .	282
HOUSSAY, F.— <i>Carnivorous Fowls of the Second Generation</i> .. .. .	282
WILSON, J. T.— <i>Early Stages in Development of Ornithorhynchus</i> .. .. .	282
MÄNNICH, H.— <i>Development of Vertebral Column of Penguin</i> .. .. .	283
LEWIN, M.— <i>Development of Beak of Penguin</i> .. .. .	283
LENHOSSÉK, M. VON— <i>Development of Corpus Vitreum</i> .. .. .	283
HERTWIG, O.— <i>Treatise on Comparative and Experimental Embryology</i> .. .. .	483
MINOT, CHARLES SEDGWICK— <i>Laboratory Text-book of Embryology</i> .. .. .	483
BOHN, G.— <i>Influence of Radium Rays on Tadpoles</i> .. .. .	483
"    " <i>Influence of Radium Rays on Ova</i> .. .. .	483
ZIEGLER, H. E.— <i>Influence of Alcohol on Development</i> .. .. .	484
MARSHALL, F. H. A.— <i>Estrous Cycle and Corpus Luteum in Sheep</i> .. .. .	484
SKROBANSKY, K. V.— <i>Yolk-Nucleus or Corpus Albicani in Vertebrates</i> .. .. .	485
SCHULTZE, B. S.— <i>Determination of Sex</i> .. .. .	485
TOKKOFF, W.— <i>Development of Spleen in Tropidonotus natrix</i> .. .. .	485
LAASER, P.— <i>Development of Teeth in Selachians</i> .. .. .	486
COURANT— <i>Preputial Glands of Rabbit</i> .. .. .	486
MARINO, F.— <i>Non-Existence of "Neutrophil" Granulations in Leucocytes of Man and Monkey</i> .. .. .	486
TOKKOFF, W.— <i>Influence of Salt Solution on Early Development of Newt's Egg</i> .. .. .	593
KOPSCH, FR.— <i>Artificial Fertilisation of the Ova of Cristiceps argentatus</i> .. .. .	593
RETZIUS, G.— <i>Spermatozoa of Acanthias vulgaris</i> .. .. .	593
LEIBER, ADOLF— <i>Structure and Development of Female Gonads of Lancelet</i> .. .. .	594
LOYEZ, MARIE— <i>Follicular Epithelium in Birds</i> .. .. .	594
WALLACE, W.— <i>Ovarian Ova and Follicles in Fishes</i> .. .. .	594
WINTREBERT, P.— <i>Influence of Central Nervous System on Development of Limbs in Amphibians</i> .. .. .	594
CAMERON, J.— <i>Development of Pineal Body in Amphibia</i> .. .. .	594
HOUGHTON, H. S.— <i>Development of Musculature and Skeleton in Spelerpes longicaudus</i> .. .. .	595
BROMAN, IVAR— <i>Circulation in Embryonic Stomach</i> .. .. .	595
SCHULTZE, O.— <i>Determination of Sex</i> .. .. .	705
BEARD, JOHN— <i>Embryology of Tumours</i> .. .. .	705
CONKLIN, EDWIN C.— <i>Cause of Inverse Symmetry</i> .. .. .	706
BATESON, W.— <i>Mendelian Heredity</i> .. .. .	706
ALLAN, BENNET M.— <i>Embryonic Development of Mammalian Ovary and Testis</i> .. .. .	706
PITTARD, E.— <i>Results of Castration in Man</i> .. .. .	707
MONTGOMERY, THOMAS H. JR.— <i>Heterotypic Maturation-Mitosis in Amphibia</i> .. .. .	707
POWERS, J. H.— <i>Acceleration and Retardation of Metamorphosis in Amblystoma tigrinum</i> .. .. .	707
WOLTERSTOFF, W.— <i>Hybrid Nature of Triton blasii</i> .. .. .	707
GOGGIO, E.— <i>Development of Lungs in Discoglossus pictus</i> .. .. .	707
MOSER, FANNY— <i>Comparative Embryology of the Swim-Bladder</i> .. .. .	708
EYCLESHYMER, A. C.— <i>Early Development of Lepidosteus</i> .. .. .	708
DAMANY, P. LE— <i>Evolution of Vertebrate Limbs</i> .. .. .	708

## b. Histology.

SCHNEIDER, K. C.— <i>Text-Book of Comparative Histology</i> .. .. .	26
HEIDENHAIN, M.— <i>Molecular Structure and Histology</i> .. .. .	26
GIARDINA, A.— <i>Theory of Cell-Division</i> .. .. .	26
HOLMGREN, E.— <i>Trophospongium of Nerve-Cells and Pancreatic Cells</i> .. .. .	26
TELLYESNICZKY, K.— <i>Criticism of Theories of Nuclear Structure</i> .. .. .	27
PENSA, A.— <i>Structure of Cartilage-Cells</i> .. .. .	27
EYCLESHYMER, A. C.— <i>Nuclear Changes in Striped Muscle-Cell of Necturus</i> .. .. .	27
PENSA, A.— <i>Endings of Nerves in Salivary Glands</i> .. .. .	27
PERRONCITO, A.— <i>Muscular Terminations of Nerve-Fibres</i> .. .. .	27
LAUNOY, L.— <i>Formation of Zymogen in Gastric Glands of Adder</i> .. .. .	27

	PAGE
SCHAEFFER, FR.— <i>Femoral Glands of Lizards</i> .. .. .	27
BETHE, A.— <i>Cell-Division</i> .. .. .	161
BOUIN, P.— <i>Spindle-Residues in Cell-Division</i> .. .. .	162
HOLMGREN, E.— <i>Trophospongia</i> .. .. .	162
SOLGER, B.—“ <i>Intracellular Threads</i> ” in <i>Ganglion-Cells of Electric Organ of Torpedo</i> .. .. .	162
SCHLATER, GUSTAV— <i>Intranuclear Space in Liver-Cells</i> .. .. .	162
SRDINKO, O. V.— <i>Structure and Development of Cartilage</i> .. .. .	163
BERTACCHINI, P.— <i>Development and Structure of Vitreous Humour</i> .. .. .	163
BÉGUIN, F.— <i>Structure of Digestive Canal in Reptiles</i> .. .. .	163
VOSELER, F.— <i>Structure of Intestinal Villi</i> .. .. .	164
BRAUER, A.—So-called “ <i>Telescopic</i> ” <i>Eye of Some Abyssal Fishes</i> .. .. .	164
VOINOV, D. N.— <i>Nature of the Centrosome</i> .. .. .	283
DANGEARD, P. A.— <i>Laws of Division</i> .. .. .	283
HERRICK, C. J.— <i>Size of Nerve-Fibres in Fishes</i> .. .. .	284
COCO, A. MOTTA, & S. DISTEFANO— <i>Nerve-Endings in White Muscle</i> .. .. .	284
ZIETZSCHMANN, E. H.— <i>Integumentary Organs of Cervidæ</i> .. .. .	284
GROSS, J.— <i>Optic Chiasma of Reptiles</i> .. .. .	285
SCHUBERG, A.— <i>Intercellular Connections</i> .. .. .	487
BOEKE, J.— <i>Minute Structure of Amphioxus</i> .. .. .	487
HATAI, SHINKISHI— <i>Efferent Neurons in Electric Lobes of Torpedo</i> .. .. .	487
STERZI, G.— <i>Blood-Vessels of the Spinal Cord of Birds</i> .. .. .	487
BURCKHARDT, R.— <i>Historical Aspects of Zoology</i> .. .. .	487
NEMILOFF, A.— <i>Amitotic Division in Vertebrata</i> .. .. .	595
PRENANT, A.— <i>Myoblasts</i> .. .. .	595
MÜNCH, K.— <i>Structure of Nucleus in Smooth Muscle</i> .. .. .	596
“ “ <i>Cross-Striped Muscle</i> .. .. .	596
HOLMGREN, E.— <i>Intracellular Threads in Nerve-Cells</i> .. .. .	596
“ “ <i>Trophospongia in Glandular Cells</i> .. .. .	596
RŽIČKA, VLADISLAV— <i>Structure of Red Blood-Corpuscles</i> .. .. .	596
ZACHARIADES, P. A.— <i>Axial Filament in the Adult Connective Tissue Fibril</i> .. .. .	596
BABES, V.— <i>Origin of Giant Cells</i> .. .. .	597
RETERER, E.— <i>Transformation of Epithelium into Connective Tissue</i> .. .. .	597
SAINT-HILAIRE, C.— <i>Intestinal Epithelium in Amphiuma</i> .. .. .	597
CIACCIO, C.— <i>Intracellular Canaliculi in Supra-renal Capsules</i> .. .. .	597
VILLARD, J.— <i>Cellular Nature of Zoochlorellæ</i> .. .. .	597
NEUFELD, RACHEL PEWSNER— <i>Canaliculi in Ganglion Cells</i> .. .. .	708
CIACCIO, C.— <i>Secretory Processes in Supra-renal Capsules</i> .. .. .	709
KOLIZOFF, N. K.— <i>Formative Elastic Structures in Cells</i> .. .. .	709
BENSLEY, R. R.— <i>Brunner’s Glands</i> .. .. .	709
HOWARD, ARTHUR D.— <i>Structure of the Outer Segments of the Rods in the Retina of Vertebrates</i> .. .. .	710

## c. General.

VASCHIDE & CL. VURPAS— <i>Vital Rhythm</i> .. .. .	28
WIEDERSHEIM, R.— <i>Comparative Anatomy of Vertebrates</i> .. .. .	28
JORDAN, D. S.— <i>Colours of Fishes</i> .. .. .	28
BERTRAND, G.— <i>Arsenic in Animals</i> .. .. .	29
RODIER, W.— <i>Rabbit Pest in Australia</i> .. .. .	29
DEAN, BASHFORD— <i>Origin of Paired Limbs of Vertebrates</i> .. .. .	29
SHINKISHI HATAI— <i>Interseapular Gland in Human Embryos</i> .. .. .	29
HANNA, W.— <i>Snake Venoms</i> .. .. .	30
ANDRES, ANGELO, & L. PESCI— <i>Permeability of Frog’s Skin</i> .. .. .	30
ZOLOTNITSKY, N.— <i>Toxotes jaculator in Captivity</i> .. .. .	30
ANNANDALE, NELSON— <i>Eating Habits of Galeopithecus volans</i> .. .. .	30
BATELLI— <i>Adrenaline</i> .. .. .	30
LAFICQUE, L.— <i>Hæmatolytic Function of Spleen</i> .. .. .	30
GAUTIER, ARMAND— <i>Fibrinogenic Substance in Albumen of Bird’s Egg</i> .. .. .	31
SCHMIDT-NIELSEN, S.— <i>Autolytic Processes in Pickled Herring</i> .. .. .	31
WOODWARD, HENRY— <i>Some Ideas of Life</i> .. .. .	142
WERNER, F.— <i>Biological Observations on Reptiles and Amphibians</i> .. .. .	165



	PAGE
SIMROTH, H.— <i>Phylogenetic Speculations</i> .. .. .	166
GOETTE, A.— <i>Text-book of Zoology</i> .. .. .	166
GOUGH, L. H.— <i>Anomalies on Head-Shields of Snakes</i> .. .. .	166
M'INTOSH, W. C.— <i>Abnormal Coloration in Pleuronectids</i> .. .. .	166
PALACKÝ, J.— <i>Geographical Distribution</i> .. .. .	167
LECHE, W.— <i>Phylogeny of Erinaceidæ</i> .. .. .	167
ZACHARIAS, O.— <i>Throwing-Net and Mud-Sucker</i> .. .. .	167
BUFFA, P.— <i>Fauna of Alpine Lakes</i> .. .. .	167
VERWORN, MAX.— <i>Biogen-Hypothesis</i> .. .. .	285
DELAGE, YVES— <i>Note on Physiological Injections</i> .. .. .	285
BOUCHARD, CH., & H. CLAUDE— <i>Experiments with Adrenalin</i> .. .. .	285
HOUSSAY, F.— <i>Modifications Observed in Carnivorous Fowls</i> .. .. .	286
SHUFELDT, R. W.— <i>Classification of Birds</i> .. .. .	286
RIDGWAY, ROBERT— <i>Birds of North and Middle America</i> .. .. .	286
CUSHING, H.— <i>Course of the Taste-Fibres</i> .. .. .	286
RACOVITZA, E. G.— <i>Note on the Great Sea Serpent</i> .. .. .	287
RIGGS, ELMER, S.— <i>Largest known Dinosaur</i> .. .. .	287
PARKER, G. H.— <i>Optic Chiasma in Teleosts</i> .. .. .	287
ALLIS, E. PH., JR.— <i>Lateral Canals and Cranial Bones of Polyodon folium</i> .. .. .	288
BARRETT-HAMILTON, G. E. H.— <i>Flight of Flying Fish</i> .. .. .	288
BURKHARDT, R.— <i>Brain of Isistius brasiliensis</i> .. .. .	289
VAILLANT, L.— <i>Fresh-water Fishes of Borneo</i> .. .. .	289
WAGNER, F. VON— <i>Parasitism among Animals</i> .. .. .	487
AYERS, HOWARD, & C. M. JACKSON— <i>Morphology of the Myxinoïds</i> .. .. .	487
EDWARDS, C. L.— <i>Note on Phrynosoma</i> .. .. .	488
ALBARRAN, J.— <i>Functional Inequality of the Kidneys</i> .. .. .	488
BERTRAND, G.— <i>Normal Presence of Arsenic in Animals</i> .. .. .	488
<i>Arsenic in Eggs of Fowl</i> .. .. .	488
GESSARD, C.— <i>Formation of Black Pigment in Tumours of Horse</i> .. .. .	488
STEFANOWSKA, M.— <i>Growth in Weight of White Mice</i> .. .. .	489
LEGROS, R.— <i>Vascular System of Amphioxus</i> .. .. .	489
ALCOCK, A.— <i>Deep-Sea Life in Indian Seas</i> .. .. .	597
GAUTIER, ARMAND— <i>Arsenic in Animals</i> .. .. .	598
SHERBORN, C. DAVIES— <i>Index Animalium</i> .. .. .	598
WEBER, MAX— <i>History of the Fauna of the Indo-Australian Archipelago</i> .. .. .	598
FÜRTH, OTTO VON— <i>Chemical Physiology of Invertebrates</i> .. .. .	598
WALLER, AUGUSTUS D., & A. DURIG— <i>Electrical Criterion of Vitality</i> .. .. .	599
MAUREL, E.— <i>Relation between Weight of Liver and Total Surface</i> .. .. .	599
DEAN, BASHFORD— <i>Coloration of Myxinoïds</i> .. .. .	599
PLATE, L.— <i>Studies on Cyclostomes</i> .. .. .	599
WIEDERSHEIM, R.— <i>"Larynx" of Ganoïds and Dipnoi</i> .. .. .	600
GUITEL, F.— <i>Specific Differences in the Kidneys of Lepadogaster</i> .. .. .	600
BOUNHIOL, J. P.— <i>Study of the Respiratory Exchanges in Water</i> .. .. .	600
POTIER, P.— <i>Temperature of the Tunny</i> .. .. .	600
EIGENMANN, C. H.— <i>Unilateral Coloration with Bilateral Effect</i> .. .. .	601
BROWN, E. E.— <i>Variations of Garter Snakes</i> .. .. .	601
CASE, E. C.— <i>American Pelycosauria</i> .. .. .	601
GADÉAU, H.— <i>How Birds make themselves understood by Man</i> .. .. .	602
SCHUSTER, W.— <i>Bird and Man</i> .. .. .	602
CARLSSON, ALBERTINA— <i>Marsupial Region of Marsupialia</i> .. .. .	710
RAMÉ, DR.— <i>Meckel's Diverticulum and Concomitant Absence of Cæcal Appendix</i> .. .. .	710
BROOM, R.— <i>Phylogeny of Vomerine Bones</i> .. .. .	710
HARRISON, H. SPENCER.— <i>Homology of the Lagena throughout Vertebrates</i> .. .. .	710
SHAMBAUGH, G. E.— <i>Circulation in Labyrinth of Ear of Pig</i> .. .. .	711
RAUTHER, M.— <i>Genital Apparatus of Bats</i> .. .. .	711
RIDGWAY, PROF.— <i>Origin of the Thorough-bred Horse</i> .. .. .	711
HATCHER, J. B.— <i>Ancestral Canidæ</i> .. .. .	711
WEYSSE, ARTHUR W.— <i>Perforation of a Vein by an Artery in the Cat</i> .. .. .	711
BÉZIER, T.— <i>Albinism in Birds and Mammals</i> .. .. .	712
LÖNNBERG, FINAR.— <i>Adaptations to Molluscivorous Diet in Varanus niloticus</i> .. .. .	712
TANDLER, JULIUS— <i>Structure of Gecko's Toes</i> .. .. .	712

	PAGE
BRADLEY, O. CHARNOCK— <i>Muscles of Mastication in Lacertilia</i> .. .. .	712
DOLLO, LOUIS— <i>Phylogeny of Chelonians</i> .. .. .	712
SIEBENROCK, FR.— <i>Classification of Trionychiæ</i> .. .. .	713
PHISALIX, M.— <i>Origin of Poison Glands in the Land Salamander</i> .. .. .	713
PARKER, G. H.— <i>Sense of Hearing in Fishes</i> .. .. .	713
SCHÖNDORFF, ALBERT— <i>Change of Colour in Trout</i> .. .. .	713
SIEDLECKI, M.— <i>Resistance of Gasterosteus aculeatus to the Osmotic Pressure of different Media</i> .. .. .	714
ZANDER, ENOCH— <i>Gill-Filters of Freshwater Fishes</i> .. .. .	714
SOLLAS, W. J. & IGERNA B. J. SOLLAS— <i>Pulvospodiyulus</i> .. .. .	714
PATTEN, W.— <i>Appendages of Tremataspis</i> .. .. .	714
EASTMAN, C. R.— <i>Peculiar Modification in Permian Dipnoans</i> .. .. .	715
SCHARFF, R. F.— <i>Lost Atlantis</i> .. .. .	715
VERRILL, ADDISON E.— <i>Bermuda Islands</i> .. .. .	716
<b>Tunicata.</b>	
GOLDSCHMIDT, R.— <i>Development of Appendicularia</i> .. .. .	167
MAGNUS, R.— <i>Function of Ganglion in Ciona intestinalis</i> .. .. .	489
ISERT, A.— <i>Digestive Glands of Monascidiæ</i> .. .. .	489
BONNIER, J., & CH. PEREZ— <i>New Type of Sulpa-Chain</i> .. .. .	490
HARTMEYER, R.— <i>Arctic Variety of Ciona intestinalis</i> .. .. .	602
BOURNE, G. C.— <i>New Molgulid</i> .. .. .	602
<b>INVERTEBRATA.</b>	
DEFLANDRE, C.— <i>Adipogenic Function of Liver in Invertebrates</i> .. .. .	31
CUENOT, L.— <i>Agglutinating and Cilio-phagocytic Organs</i> .. .. .	31
WESENBERG-LUND, C.— <i>Relict Fauna of Lake Furesö</i> .. .. .	289
DADAY, E. VON.— <i>Microscopic Freshwater Animals of Balaton</i> .. .. .	716
<b>Mollusca.</b>	
<i>a. Cephalopoda.</i>	
WILLIAMS, L. W.— <i>Vascular System of Squid</i> .. .. .	31
CHUN, CARL— <i>Nature and Development of Chromatophores</i> .. .. .	167
JOURDAIN, L.— <i>New Cuttle-fishes</i> .. .. .	168
SCHWEIKART, A.— <i>Chorion and Micropyle in Cephalopods</i> .. .. .	168
BERGMANN, W.— <i>Structure of Ovary in Cephalopods</i> .. .. .	490
GESSARD, C.— <i>Oxidising Ferments in Ink of Cuttlefishes</i> .. .. .	490
GRAVIER, CH.— <i>Nervous System of Nautilus</i> .. .. .	490
CHUN, C.— <i>Remarkable Young Form of Cephalopod</i> .. .. .	716
HAMLIN-HARRIS, R.— <i>Statocysts of Cephalopods</i> .. .. .	716
JOUBIN, L.— <i>Loligo media</i> .. .. .	716
JOUBIN, L.— <i>Hetroteuthis weberi</i> .. .. .	716
THEISING, CURT— <i>Spermatogenesis in Cephalopods</i> .. .. .	717
<i>γ. Gastropoda.</i>	
SMITH, B.— <i>Notes on Species of Fulgur</i> .. .. .	32
SIMROTH, H.— <i>Recent Researches on Gastropods</i> .. .. .	32
ANCEL, P.— <i>Sex Determination of Gametes in Hermaphrodite Gonads</i> .. .. .	32
BERGH, R.— <i>Opisthobranchs from Gulf of Siam</i> .. .. .	32
HESSE, R.— <i>Retina of Gastropod Eye</i> .. .. .	168
ILLINGWORTH, J. F.— <i>Structure of Lucapina crenulata</i> .. .. .	169
DUBOIS, R.— <i>Purple of Dog-Whelk</i> .. .. .	170
TOIZAUER, R. J.— <i>Relations of Kidneys and Gonads in Haliotis</i> .. .. .	170
GRABAN, AMADEUS W.— <i>Studies of Gastropod Shells</i> .. .. .	290
STIASNY, G.— <i>Kidney of Helix pomatia</i> .. .. .	290
YUNG, EMILE— <i>Sense of Smell in Snails</i> .. .. .	290
LETELLIER, A.— <i>Purple of Purpura lapillus</i> .. .. .	290
GLASER, O. C.— <i>Nematocysts of Nudibranchs</i> .. .. .	291
GLAMANN, G.— <i>Tracheopulmonate Gastropods</i> .. .. .	291

	PAGE
KÜNKEL, K.— <i>Locomotion of Slugs</i> .. .. .	490
KOEHLER, R., & C. VANEY— <i>Entosiphon Deimatis Parasitic in an Abyssal Holothuroid</i> .. .. .	491
PAGE, S.— <i>Structure of Pontiothauma</i> .. .. .	491
DAVIS, J. R. AINSWORTH, & H. J. FLEURE— <i>Memoir on the Limpet</i> .. .. .	491
HEATH, H.— <i>Function of Subradular Organ in Chiton</i> .. .. .	492
BREYNE, C. DE— <i>Follicular Cells in Gouuds of Gastropods</i> .. .. .	492
BAVAY, A.— <i>Aëriferous Canal in Shell of certain Pulmonata</i> .. .. .	492
WESTERLUND, C. A.— <i>Synopsis of Palæarctic Forms of Clausilia</i> .. .. .	492
MEISENHEIMER, J.— <i>New Pteropod</i> .. .. .	603
KÜNKEL, K.— <i>Breeding Experiments with Sinistral Snails</i> .. .. .	603
NIERSTRASZ, H. F.— <i>New Solenogastres</i> .. .. .	717
FAHRINGER, J.— <i>Storing-Kidney in Carinaria mediterranea</i> .. .. .	717
COCKERELL, T. D. A.— <i>Variation in the Genus Ashmunella</i> .. .. .	717
GRABAU, AMADEUS— <i>Gastropod Studies</i> .. .. .	718
ANGEL, P.— <i>Sexual Differentiation in the Hermaphrodite Gland of Limax maximus</i> .. .. .	718

### 5. Lamellibranchiata.

BAKER, F. C.— <i>Monstrosities in Bivalves</i> .. .. .	33
BOUTAN, L.— <i>Innervation of Mantle of Pecten</i> .. .. .	33
JAMESON, H. LYSTER— <i>Formation of Pearls</i> .. .. .	170
JOBEIT— <i>Muscular Apparatus of Anomia</i> .. .. .	171
DALL, W. H.— <i>Synopsis of Carditacea</i> .. .. .	171
DUBOIS, R.— <i>Origin of Pearls in Mytilus gallo-provincialis</i> .. .. .	291
M'INTOSH, W. C.— <i>Frequency of Occurrence of Pearls</i> .. .. .	493
ANDRUSOFF, N.— <i>Brackish Water Cockles</i> .. .. .	493
VORGES, DOMET DE.— <i>Utilisation of Carbonate of Lime by Anodonta</i> .. .. .	718
BAKER, F. C.— <i>Rib Variation in Cardium</i> .. .. .	718

## Arthropoda.

### a. Insecta.

HOLMGREN, NILS— <i>Morphological Significance of Chitinous Cuticle</i> .. .. .	33
SNOW, LETITIA M.— <i>Insects of the Drift Line</i> .. .. .	33
BACHMETJEW, P.— <i>Calorimetric Measurements in reference to Pupæ of Lepidoptera</i> .. .. .	33
VERHOEFF, K. W.— <i>Innervation of Metacephalic Segment</i> .. .. .	34
HOLMGREN, NILS— <i>Excretory Processes in Insects</i> .. .. .	34
KELLOGG, V. L.— <i>Mouth-parts of Insects</i> .. .. .	34
COBELLI, RUGGERO— <i>Stridulation of Death's Head Moth</i> .. .. .	34
GODMAN, F. D., & O. SALVIN— <i>Butterflies of Borderland between North and South America</i> .. .. .	34
DIKEY, F. A.— <i>Seasonal Dimorphism in Butterflies</i> .. .. .	35
LEVRAT, D., & A. CONTE— <i>Colour of Silk</i> .. .. .	35
FIELD, ADELE M.— <i>Study of an Ant</i> .. .. .	35
MELANDER, A. L.— <i>Gynandromorphism in Hilara wheeleri sp. n.</i> .. .. .	36
VOINOV, D. N.— <i>Spermatogenesis in Cybister ræselii</i> .. .. .	36
ANNANDALE, NELSON— <i>Malayan Phasmidæ and a Flower-like Beetle Larva</i> .. .. .	36
CARAZZI, D.— <i>Berlese's Bursa in Acanthia lectularia L.</i> .. .. .	36
KELLOGG, V. L.— <i>Larva of Giant Crane Fly</i> .. .. .	36
MIALL, L. C., & G. GILSON— <i>Crickets of Aquatic Habits</i> .. .. .	36
MCCLEUNG, C. E.— <i>Spermatogenesis of Locustidæ</i> .. .. .	37
ESCHERICH, K.— <i>Development of Nervous System in Muscidæ</i> .. .. .	37
BORDI, A.— <i>Species of Mosquitos concerned in Diffusion of Malaria</i> .. .. .	37
TAVARES, J. DA SILVA— <i>Studies on Zooecidia</i> .. .. .	38
KELLOGG, V. L., & SHINKAI I. KUWANA— <i>Mallophaga from Galapagos Birds</i> .. .. .	38
FOREL, A., & H. DUFOUR— <i>Sensitiveness of Ants to Ultra-Violet and Röntgen Rays</i> .. .. .	171
SOSNOWSKI, J.— <i>Physiological Study of Metamorphosis</i> .. .. .	172
WASMANN, E.— <i>Pseudogyny in Formica, and its Cause</i> .. .. .	172

	PAGE
DUCKE, A.— <i>Stingless Bees (Melipona) of Pará</i> .. .. .	172
WASMANN, E.— <i>New Termites, Termitophils, and Myrmecophils</i> .. .. .	172
" <i>Guests of the Dorylinæ</i> .. .. .	172
TOWER, W. L.— <i>Exuvial Glands in Insects</i> .. .. .	173
PORTA, A.— <i>Hepatic Function in Insects</i> .. .. .	173
METALNIKOFF, S.— <i>Excretion in Gnat Larvæ</i> .. .. .	173
GADD, G.— <i>Food-Canal of Larvæ of Cuckoo-Spit</i> .. .. .	174
ENDERLEIN, GÜNTHER— <i>Normal Asymmetry of the Wings in Naucoris cimicoides</i> ..	174
VEVEY, S. ARTAULT DE— <i>Injurious Influence of Thrips on Man</i> .. .. .	174
REH, L.— <i>Statistical Study of Scale Insects on Fruit</i> .. .. .	174
VOSSLER, J.— <i>Chemical Defence and other Adaptations in North African Orthoptera</i>	174
LINDEN, M. GRÄFIN VON— <i>Sensory Hairs on Pupa of Papilio podalirius</i> .. .. .	175
WANDOLLECK, B.— <i>Appendicular Nature of Abdominal Styles</i> .. .. .	175
VERHOEFF, K. W.— <i>Trochanter and Præfemur</i> .. .. .	175
GRÜNERG, K.— <i>Studies on the History of the Germ-Cells in Lepidoptera</i> .. .. .	175
LISTER, J. J.— <i>Notes on Liparids</i> .. .. .	176
JOHNSON, W. F., & J. N. HALBERT— <i>Beetles of Ireland</i> .. .. .	176
FELT, E. P.— <i>Grapevine Root Worm</i> .. .. .	177
MAYER, A. G.— <i>Evolution of Colour-Patterns in Lepidoptera</i> .. .. .	291
KELLOGG, V. L.— <i>Net-winged Midges</i> .. .. .	292
PETRUNKEWITSCH, A.— <i>History of Polar Bodies in Drone-Ova</i> .. .. .	293
TOWER, W. L.— <i>Development of Wings in Beetles</i> .. .. .	293
GRAY, ST. GEORGE— <i>Screw-Worms in St. Lucia</i> .. .. .	293
WESCHÉ, W.— <i>Parasite of the Wallaby</i> .. .. .	294
LÉGER, LOUIS— <i>Parasitic Bacteria in Intestine of Chironomus Larvæ</i> .. .. .	294
SCHENK, O.— <i>Antennary Sense-Organs in Lepidoptera and Hymenoptera</i> .. .. .	294
RIBAGA, COSTANTINO— <i>Insect against Insect</i> .. .. .	294
PICTET, ARNOLD— <i>Changes in Imagines induced by Change of Diet in Caterpillars</i>	294
GULDE, J.— <i>Dorsal Glands of Larvæ of Hemiptera-Heteroptera</i> .. .. .	294
SILVESTRI, F.— <i>A Most Primitive Insect</i> .. .. .	295
ESCHERICH, K.— <i>Studies on Thysanura</i> .. .. .	295
PANTEL, J., & R. DE SINÉTY— <i>Development of Spermatid of Notonecta glauca</i> ..	295
"    " <i>Acrosome of Spermatid of Notonecta</i> .. .. .	295
"    " <i>"Neubkern" and Nuclein Movement in Spermatid</i>	296
"    " <i>of Notonecta glauca</i> .. .. .	296
REGEN, J.— <i>Stridulating Organs in Saltatorial Orthoptera</i> .. .. .	296
BORDAS, L.— <i>Structure of Gizzard of Carabidæ</i> .. .. .	296
SELLARDS, E. H.— <i>Palæozoic and Recent Cockroaches</i> .. .. .	296
LAPOUGE, G. DE— <i>Phylogeny of Carabus</i> .. .. .	493
DEGENER, P.— <i>Post-Embryonic Development of Intestine</i> .. .. .	493
WAGNER, FR.— <i>Variations of Pieris napi</i> .. .. .	493
SHELFORD, R.— <i>New Case of Protective Mimicry in a Caterpillar</i> .. .. .	494
DIXEY, F. A.— <i>Notes on Seasonal Dimorphism</i> .. .. .	494
TICHOMIROFF, A.— <i>Artificial Parthenogenesis in Silk Moth</i> .. .. .	494
BRUES, C. T.— <i>Development of Stylopoidæ</i> .. .. .	494
DYAR, HARRISON G.— <i>Lepidoptera of North America</i> .. .. .	495
BORDAS, L.— <i>Mandibular Glands of Larval Lepidoptera</i> .. .. .	495
GRÜNBERG, K.— <i>Oogenesis in Lepidoptera</i> .. .. .	496
BÖRNER, CARL— <i>Joints of the Walking Legs in Insects and Myriopods</i> .. .. .	604
BAUER, V.— <i>Metamorphosis of Nervous System in Insects</i> .. .. .	604
BULMAN, G. W.— <i>Insects and Petal-less Flowers</i> .. .. .	604
LOWE, ERNEST, E.— <i>Insects and Flowers</i> .. .. .	604
VOINOV, D. N.— <i>Dimorphic Spermatozoa in Butterflies</i> .. .. .	605
KOLBE, H.— <i>Preocious Development of Pupal and Imaginal Organs in Caterpillars</i>	605
ZANDER, E.— <i>Male Genital Appendages in Lepidoptera</i> .. .. .	605
HARRIS, W. H.— <i>Teeth of Diptera</i> .. .. .	606
MEUNIER, F.— <i>Diptera from Amber</i> .. .. .	606
GALLI-VALERIO, BRUNO, & G. ROOHAZ— <i>Mosquitos in Winter</i> .. .. .	606
PITTALUGA, G.— <i>Anopheles in the Iberian Peninsula</i> .. .. .	606
VANEY, C., & A. CONTE— <i>Dipterous Parasite of the Vine-pest Ialtica</i> .. .. .	606
WESCHÉ, W.— <i>Male Organs of Scatophaga</i> .. .. .	607
BORDAS, L.— <i>Alimentary Tract of Silphidæ</i> .. .. .	607

	PAGE
LAUTERBORN, L.— <i>Tracheal Gills on Legs of Larval Perlid</i> .. .. .	607
KÖHLER, A.— <i>Formation of Chorion in Pyrrhocoris apterus</i> .. .. .	607
VERHOEFF, K. W.— <i>Systematic Position of Hemimerus</i> .. .. .	607
SEATON, FRANCES— <i>Compound Eyes of Machilis</i> .. .. .	608
LOVELL, JOHN H.— <i>Insects and Floral Colours</i> .. .. .	718
OUDEMANS, J. Th.— <i>Position of Repose in Lepidoptera</i> .. .. .	719
ROGERS, W. S.— <i>Protective Resemblance in Butterflies</i> .. .. .	719
MEVES, F.— <i>Spermatogenesis in Drones</i> .. .. .	719
DREYLING, L.— <i>Wax-making Organ of Bee</i> .. .. .	719
COBELLI, RUGGERO.— <i>Hibernation of Ants</i> .. .. .	719
RENGEL, C.— <i>Connection between Mid-Gut and Hind-Gut in Larval Hymenoptera</i>	720
GRÜNBERG, K.— <i>Interesting Case of Parasitism</i> .. .. .	720
SHARP, D.— <i>Beetle Embedded in Wall of Human Intestine</i> .. .. .	720
TOWER, W. L.— <i>Coloration of Coleoptera</i> .. .. .	720
PEAL, H. W.— <i>Vasiform Orifice of the Aleurodidæ</i> .. .. .	721
PINE-Beetle .. .. .	721
STEBBING, E. P.— <i>Economic Entomology</i> .. .. .	721
ENDERLEIN, GUNTHER— <i>Copeognathæ from Kameroun</i> .. .. .	721
LEA, ARTHUR M.— <i>Tasmanian Phasmid</i> .. .. .	721
AQUATIC Insects of New York State .. .. .	722
MORSE, MAX— <i>North American Trichodectidæ</i> .. .. .	722

### β. Myriopoda.

ROSSI, G.— <i>Structure of Myriopods</i> .. .. .	177
BRUNTZ, L.— <i>Labial Excretory Organs and a Phagocytic Organ in Diplopoda</i> ..	177
ROSSI, G.— <i>Odoriferous Glands of Julus communis</i> .. .. .	297
ATTEMS, CARL GRAF— <i>New Myriopods</i> .. .. .	297
POCOCK, R. I.— <i>New Clasp ing Organ in a Centipede</i> .. .. .	496
WILLIAMS, S. R.— <i>Variation in Lithobius forficatus</i> .. .. .	608
HENNINGS, CURT— <i>Marine Myriopods</i> .. .. .	722
VERHOEFF, K. W.— <i>Intercalary Segments</i> .. .. .	722

### γ. Prototracheata.

BOUVIER, E. L.— <i>Modes of Development in Onychophora</i> .. .. .	297
EVANS, RICHARD— <i>New Species of Peripatus</i> .. .. .	608

### δ. Arachnida.

BÖSENBERG, W.— <i>Monograph on German Spiders</i> .. .. .	38
TROUSSART, E.— <i>Gamasus auris</i> .. .. .	177
THOR, SIG.— <i>Thick-skinned Acarina</i> .. .. .	177
STSCHELKANOVITZEFF, J. P.— <i>Segments of Pseudoscorpionidæ</i> .. .. .	298
PAPPENHEIM, P.— <i>Development of Dolomedes fimbriatus</i> .. .. .	298
RIBAGA, C.— <i>New Hydrachnida and Ixodidæ from South America</i> .. .. .	298
SHEEP SCAB .. .. .	298
HALBERT, J. N.— <i>Irish Fresh-water Mites</i> .. .. .	496
NEUMANN, L. G.— <i>Species of Ixodidæ</i> .. .. .	496
BÖSENBERG, W.— <i>Spiders of Germany</i> .. .. .	497
DAHL, FR.— <i>Copulation in Spiders</i> .. .. .	609
SOAR, C. D.— <i>Living Hydrachnid Larvæ in Trout's Stomach</i> .. .. .	609
RUCKER, AUGUSTA— <i>New Species of Keneia</i> .. .. .	609
SCHIMKEWITSCH, W.— <i>Development of Telyphonus caudatus</i> .. .. .	723

### ε Crustacea.

LABBÉ, A.— <i>Fibrillar Continuity of Epithelial Cells and Muscles in Nebalia</i> ..	38
BRUNTZ, L.— <i>Excretory Organs in Mulacostraca</i> .. .. .	38

	PAGE
LERAT, P.— <i>Maturation-Phenomena in Oogenesis and Spermatogenesis of Cyclops strenuus</i> .. .. .	319
MURLIN, J. R.— <i>Absorption and Secretion in Terrestrial Isopods</i> .. .. .	319
KOEFFEL, E.— <i>Genus Amphion</i> .. .. .	319
LAUNOY, L.— <i>Nucleolar Changes in Secretion of Hepato-Pancreatic Cells of Hermit-Crab</i> .. .. .	178
JORDAN, H.— <i>Function of Mid-Gut Gland of Crayfish</i> .. .. .	178
BONNIER, J.— <i>Two New Types of Epicaridæ</i> .. .. .	178
CHEVREUX, ED.— <i>Marine Species of Hyalella</i> .. .. .	178
MEISENHEIMER, J.— <i>Crustacea and Pantopoda</i> .. .. .	178
KOTTE, E.— <i>Integumentary Sense-Organs of Deep-Sea Decapods</i> .. .. .	299
BRUNTZ, L.— <i>Excretion in Cirripedia</i> .. .. .	299
HALPERN, B.— <i>Ventral Nerve-Cord of Crayfish</i> .. .. .	299
CAULLERY, M., & F. MESNIL— <i>Gall-forming Copepod in an Anemone</i> .. .. .	300
SAYCE, O. A.— <i>Australian Phyllopods</i> .. .. .	300
HANSEN, H. J.— <i>New Species of Sergestes</i> .. .. .	497
RIDEWOOD, W. G.— <i>New Genus of Copepod</i> .. .. .	497
KIRKALDY, G. W.— <i>Note on Phototropism of Daphnia</i> .. .. .	497
SCOURFIELD, D. J.— <i>Synopsis of British Fresh-water Cladocera</i> .. .. .	497
KEEBLE, F., & F. W. GAMBLE— <i>Colour-Physiology of Higher Crustacea</i> .. .. .	609
THIENEMANN, A.— <i>Statocysts in an Isopod</i> .. .. .	610
THOMPSON, MILLET T.— <i>Rare Thalassinid and its Larva</i> .. .. .	611
WALKER, ALFRED O.— <i>Antarctic Amphipods</i> .. .. .	611
LÖNNBERG, EIMAR— <i>Intermediate Form between Mysis oculata and Mysis relicta</i> .. .. .	611
CHEVREUX, E.— <i>Abyssal Lysianassids</i> .. .. .	611
HANSEN, H. J.— <i>Anuropus and Bathynomus</i> .. .. .	611
SCOTT, THOMAS— <i>Copepoda from Farøe Channel</i> .. .. .	612
HOLMES, F. J.— <i>Death-Feigning in Terrestrial Amphipods</i> .. .. .	723
FABRE-DOMERGUE & E. BIÉTRIX— <i>Emergence of Lobster Larvæ</i> .. .. .	723
HARRIS, J. ARTHUR— <i>Habits of Cambarus</i> .. .. .	723
HOLMES, S. J.— <i>North American Amphipods</i> .. .. .	723

Annulata.

FOOT, K., & E. C. STROBELL— <i>Cocoons of Earthworm</i> .. .. .	40
ABEL, MAX— <i>Regeneration in Limicolæ</i> .. .. .	179
DUBOSQ, O.— <i>New Species of Alma</i> .. .. .	180
LIVANOW, N.— <i>Hemicleipsis and allied Genera</i> .. .. .	180
ROSA, D.— <i>Typical Chloragogen of Oligochæta</i> .. .. .	300
MAYER, A. G.— <i>Atlantic Palolo</i> .. .. .	300
GRAVIER, CH.— <i>Fresh-water Polychæts</i> .. .. .	301
FAUVEL, P.— <i>Otocysts of Polychæta</i> .. .. .	301
COWLES, R. P.— <i>Notes on Polygordius</i> .. .. .	301
SPIESS, CAMILLE— <i>Alimentary Tract of the Leech</i> .. .. .	302
SOULIER, A.— <i>Revision of Annelids of the Certe Region</i> .. .. .	498
TREADWELL, A. R.— <i>Artificial Parthenogenesis in Egg of Podarke obscura</i> .. .. .	498
KOWALEVSKY, A.— <i>Phenomena of Fertilisation in Hæmenteria costata</i> .. .. .	498
STEVENS, N. M.— <i>Oogenesis and Spermatogenesis in Sagitta bipunctata</i> .. .. .	498
SPIESS, C.— <i>Minute Structure of the Alimentary Canal of the Leech</i> .. .. .	612
HÉRUBEL, MARCEL A.— <i>Distribution and Affinities of Sipunculids</i> .. .. .	612
Notes on Sipunculids .. .. .	613
HÉRUBEL, MARCEL A.— <i>Endothelial Derivatives and Pigment-Bodies in Gephyreans</i> .. .. .	613
BERGMANN, W.— <i>Gonads of Hestione sicula</i> .. .. .	613
MALAQUIN, A.— <i>Development of Metameres in Salmacina dysteri</i> .. .. .	613
FOOT, KATHERINE, & E. C. STROBELL— <i>Sperm Centrosome and Aster of Allolobophora fetida</i> .. .. .	724
SIEDLECKI, M.— <i>Rôle of Amœbocytes in Polynnia nebulosa</i> .. .. .	724
IZUKA, AKIRA— <i>Observations on the Japanese Palolo (Ceratocephale osawai sp. n.)</i> .. .. .	724
AUGENER, H.— <i>Studies on Gephyrea</i> .. .. .	725
GÜNTHER, R. T.— <i>Distribution of Mid-water Chætogonatha in North Atlantic</i> .. .. .	725

Nematohelminthes.		PAGE
BANCROFT, T. L.— <i>Intermediate Host of Filaria immitis</i> .. .. .	40	40
STILES, C. W., & W. A. FRANKLAND— <i>Vinegar Eel in Human Bladder</i> .. .. .	40	40
MICHEL, A.— <i>Species of Rhabditis</i> .. .. .	180	180
VOLTZENLOGEL, E.— <i>Hind-End of Ascaris</i> .. .. .	180	180
LOW, G. C.— <i>Filaria perstans</i> .. .. .	302	302
GOLDSCHMIDT, R.— <i>Sense-Organs of Ascaris</i> .. .. .	499	499
MANSON, SIR PATRICK— <i>Life-Span of Filaria medinensis</i> .. .. .	614	614
MIURA, K., & V. NISHICUKI— <i>Unfertilised Ova of Ascaris in Human Fæces</i> .. .. .	614	614
MONTGOMERY, THOMAS H., JR.— <i>Structure of Paragordius varius Leidy</i> .. .. .	725	725

### Platyhelminthes.

IHERING, H. VON— <i>Parasitic Worms as Aids in Zoogeographical Investigation</i> ..	40	40
ZACHARIAS, O.— <i>New Turbellarian</i> .. .. .	41	41
GRAFF, L. VON— <i>Notes on Gyrodactylus hermaphroditus Ehrbg.</i> .. .. .	41	41
MÜLLER, JOS.— <i>Studies on Bipalium Species</i> .. .. .	41	41
LOOSS, A.— <i>Trematodes from Marine Turtles</i> .. .. .	41	41
PRATT, H. S.— <i>North American Trematodes</i> .. .. .	41	41
STAFFORD, J.— <i>American Representatives of Distomum variegatum</i> .. .. .	41	41
PERRONCITO— <i>Production of Hyatid Cysts from Scolices</i> .. .. .	42	42
SCHNEIDER, G.— <i>Life-History of Bothriocotenia proboscidea</i> .. .. .	42	42
LINSTOW, O. v.— <i>Echinococcus alveolaris</i> .. .. .	181	181
BOAS, J. E. V.— <i>Triplotænia mirabilis</i> .. .. .	181	181
BARTELS, E.— <i>Cysticercus fasciolaris</i> .. .. .	181	181
RÖSSLER, P.— <i>Minute Structure of Cysticerci</i> .. .. .	182	182
BUTTEL-REEPEN, H. VON— <i>Distomum clavatum</i> .. .. .	182	182
STAFFORD, J.— <i>American Representatives of Distomum cynuoides</i> .. .. .	182	182
MÜLLER, J.— <i>Contributions to Study of Bipaliidæ</i> .. .. .	182	182
STUMMER-TRAUNFELS, R. RITTER VON— <i>Fresh-water Polyclad</i> .. .. .	182	182
BERGENDAL, D.— <i>Callinera bürgeri</i> .. .. .	182	182
STILES, C. W., & L. TAYLOR— <i>Asiatic Human Parasites</i> .. .. .	302	302
HASWELL, W. A.— <i>New Gyrocotyle</i> .. .. .	302	302
PRATT, H. S.— <i>North American Trematodes</i> .. .. .	303	303
MAREJNOWSKI, E.— <i>Sub-Œsophageal Ganglion of Liver-Fluke</i> .. .. .	303	303
OSBORN H. L.— <i>Peculiar Fluke</i> .. .. .	303	303
ZSCHOKKE, F.— <i>Marine Parasites in Fresh-water Fishes</i> .. .. .	499	499
„ „— <i>New Case of Dipylidium caninum in Man</i> .. .. .	499	499
ROSSETER, T. B.— <i>Drepanidotænia tenuirostris</i> .. .. .	499	499
MACLAREN, N.— <i>Skin of Trematodes</i> .. .. .	500	500
COHN, I.— <i>Notes on Trematodes</i> .. .. .	500	500
JOHNSTON, S. J.— <i>New Distomum from Sawfish Shark</i> .. .. .	500	500
CURTIS, WINTERTON C.— <i>Life-History and Reproduction of Planaria maculata</i> ..	614	614
MACCULLUM, W. G.— <i>New Monostome from Snapping Turtle</i> .. .. .	615	615
JANICKI, C. v.— <i>Behaviour of Chromatin in Segmentation of Ocum of Gyrodactylus</i>	615	615
LÜHE, MAX— <i>Peculiar Cestode from Acanthias</i> .. .. .	615	615
SCHNEIDER, GUIDO— <i>Bothriocephalus in the Baltic Herring</i> .. .. .	615	615
GAMBLE, DR. F. W., & F. KEEBLE— <i>Bionomics of Convolvata Roscoffensis</i>	725	725
HASWELL, W. A.— <i>Two Remarkable Sporocysts from Mytilus latus</i> .. .. .	726	726
PUNNETT, R. C.— <i>Nemerteanus of Norway</i> .. .. .	726	726

### Incertæ Sedis.

VANEY, C., & A. CONTE— <i>Budding of Rhabdopleura normanni</i> .. .. .	42	42
RITTER, W. E.— <i>Heart of Enteropneusta</i> .. .. .	42	42
„ „— <i>Movements of Enteropneusta</i> .. .. .	43	43
KLUNZINGER, C. B.— <i>Ptychodera erythraea from the Red Sea</i> .. .. .	183	183
ANDERSON, K. A.— <i>Re-discovery of Cephalodiscus McIntosh</i> .. .. .	303	303
POCHE, FR.— <i>Correct Name of Genus Phoronis</i> .. .. .	500	500
CALVET, L.— <i>New Species of Alcyonidium</i> .. .. .	500	500

	PAGE
CUMINGS, E. R.— <i>Evolution of Platystrophia</i> .. .. .	615
ROBERTSON, ALICE— <i>Embryonic Fission in the Genus Crisia</i> .. .. .	726
.. .. . <i>Studies in Pacific Coast Entoprocta</i> .. .. .	727
.. .. . <i>Ascorhiza and Related Alcyonidia</i> .. .. .	727

**Rotifera.**

DIXON-NUTTALL, F. R., & REV. R. FREEMAN— <i>The Rotatorian Genus Diaschiza</i> <i>A Monographic Study with Description of a New Species</i> (Plates I.–IV.)	1, 129
WESCHÉ, W.— <i>New Male Rotifers</i> .. .. .	183

**Rotatoria.**

MONTGOMERY, MR. THOS. H.— <i>Morphology of the Rotatorian Family Flosculariadae</i> .. .. .	727
---	-----

**Echinoderma.**

KOEHLER, R., & F. A. BATHER— <i>New Crinoid</i> .. .. .	43
DONCASTER, L.— <i>Rearing Later Stages of Echinoid Larvæ</i> .. .. .	183
BELL, F. JEFFREY— <i>Antarctic Echinoderms</i> .. .. .	303
STEVENS, N. M.— <i>Experimental Studies on Eggs of Echinus microtuberculatus</i> ..	501
LOEB, JACQUES— <i>Experiments on Oca of Starfish</i> .. .. .	501
MONKS, SARAH P.— <i>Regeneration of the Body of a Starfish</i> .. .. .	616
CAULLERY, MAURICE & MICHEL SIEDLECKI— <i>Phagocytic Absorption of Sex-Cells in Echinocardium cordatum</i> .. .. .	727
GRABAU, A. W.— <i>Development of the Biserial Arm in Certain Crinoids</i> .. .. .	728
NICHOLS, A. R.— <i>List of Irish Echinoderms</i> .. .. .	728
NORMAN, CANON A. M.— <i>Echinoderms of East Finmark</i> .. .. .	728

**Cœlentera.**

ADERS, W. M.— <i>Division of Protohydra leuckarti</i> .. .. .	44
BILLARD, A.— <i>Observations and Experiments on Clava squamata</i> .. .. .	44
CITRON, E.— <i>Minute Structure of Syncoryne sarsii</i> .. .. .	44
TORREY, H. B.— <i>Hydroids of Pacific Coast of North America</i> .. .. .	44
GRAVIER, CH.— <i>Adult Pelagic Cerianthid</i> .. .. .	44
CARLQVIST, O.— <i>Actiniaria of the Olga Expedition</i> .. .. .	44
DUERDEN, J. E.— <i>Significance of Budding and Fission in Madreporaria</i> .. .. .	45
TORREY, H. B.— <i>Notes on Anemones and Variation in Metridium</i> .. .. .	45
GARDINER, J. STANLEY— <i>Structure and Development of Flabellum</i> .. .. .	184
.. .. . <i>Notes on Variation, Protandry, and Senescence in Flabellum</i>	184
MOROFF, TH.— <i>New Pennatulacea and Gorgonacea</i> .. .. .	184
TÖRNQUIST, SV. L.— <i>Studies on Graptolites</i> .. .. .	184
ADERS, W. M.— <i>Spermatogenesis in Hydra and Aurelia</i> .. .. .	304
GÜNTHER, R. T.— <i>Cœlentera from Intermediate Waters of North Atlantic</i> ..	304
PERKINS, H. F.— <i>Development of Gonionema murbachii</i> .. .. .	501
TORREY, H. B.— <i>Hydroids of Pacific Coast of North America</i> .. .. .	502
KREMPF, A.— <i>Peculiar Structure in Certain Hexacorallia</i> .. .. .	502
BILLARD, A.— <i>Excretory Cells in Hydroids</i> .. .. .	616
BOURNE, G. C.— <i>Some New and Rare Corals from Funafuti</i> .. .. .	616
KISHINOUE, KAMAKICHI— <i>Species of Corallium</i> .. .. .	616
HARGITT, C. W.— <i>North American Scyphomedusæ</i> .. .. .	617
LEON, N.— <i>Prophysema hœckelii</i> .. .. .	617
BÜRGER, OTTO— <i>Commensalism between Sea-Anemone and Crab</i> .. .. .	728
KÜKENTHAL, W.— <i>Revision of the Nephthyidæ</i> .. .. .	728
HALL, T. S.— <i>Occurrence of Monograpus in New South Wales</i> .. .. .	728
KERFORNE, E.— <i>Development of Graptolites</i> .. .. .	729
BEECHER, CHARLES E.— <i>The Genus Romingeria</i> .. .. .	729



## Porifera.

	PAGE
COTTE, J.— <i>Ingestion of Food-Particles in Sycandra raphanus</i> .. .. .	304
“ “ <i>Metabolism in Sponges</i> .. .. .	314
SCHULZE, F. E.— <i>Indian Triaxonia</i> .. .. .	304
IJIMA, ISAO— <i>Studies on Hexactinellids</i> .. .. .	502
LENDENFELD, R. V.— <i>Note on Spongilla fragilis</i> .. .. .	502
VOSMAER, G. C. J.— <i>Siliceous Spicules</i> .. .. .	503
ZACHARIAS, O.— <i>Carterius Stepanowi Dyb.</i> .. .. .	617
TOPSENT, E.— <i>Asterosteptidæ</i> .. .. .	729
THIELE, JOH.— <i>Inufficiently Described Monaxonia</i> .. .. .	729
PRESWISCH, JOSEF— <i>Calcareous Sponges from the Pacific</i> .. .. .	729
BAAR, R.— <i>Pacific Horny Sponges</i> .. .. .	729

## Protozoa.

PORTA, A.— <i>Reproduction of Acanthometridæ</i> .. .. .	45
BORGERT, A.— <i>New Trypylea</i> .. .. .	45
PERRONCITO— <i>Lambliæ intestinalis Fatal to Rabbits</i> .. .. .	46
MOROFF, TH.— <i>New Species of Chilodon</i> .. .. .	46
LAVERAN, A., & F. MESNIL.— <i>Parasites of an Asiatic Tortoise</i> .. .. .	46
LAVERAN, A.— <i>Trypanosomes from Transvaal Cattle</i> .. .. .	46
LAVERAN, A., & F. MESNIL.— <i>Hæmatozoa in Marine Fishes</i> .. .. .	46
EARLAND, A.— <i>Cymbalopora bulloides</i> .. .. .	185
SIEDLECKI— <i>New Coccidian</i> .. .. .	185
MILLETT, F. W.— <i>Report on the Recent Foraminifera of the Malay Archipelago collected by Mr. A. Durrand, F.R.M.S.—Part XIV. (Plate V.)</i> .. .. .	253
CONTE, A., & C. VANEY— <i>Nuclear Emissions in Protozoa</i> .. .. .	305
PENARD, E.— <i>New Rhizopod</i> .. .. .	305
DANGEARD, P. A.— <i>Nuclear Division of Amœba</i> .. .. .	305
SHERLOCK, R. L.— <i>Foraminifera of Raised Reefs of Fiji</i> .. .. .	306
ENRIQUES, P.— <i>Adaptability of Marine Infusorians of Fresh Water</i> .. .. .	306
RENAULT, B.— <i>Fossil Infusorians</i> .. .. .	306
POCHE, FR.— <i>Flagellate Parasites in Siphonophora</i> .. .. .	306
DANGEARD, P. A.— <i>Structure of Treponomas agilis Dujardin</i> .. .. .	306
MANSON, PATRICK— <i>Trypanosomiasis</i> .. .. .	307
FOÀ, ANNA— <i>Nature of Cytoryctes vaccinæ</i> .. .. .	307
BLANCHARD, L. F.— <i>Cœlonic Gregarine in a Beetle</i> .. .. .	307
LAVERAN, A.— <i>Hæmogregarine of Ophidia</i> .. .. .	307
MENGARINI, MARGHERITA T.— <i>Conjugation of Amœbæ</i> .. .. .	503
SCHEWIAKOFF, W.— <i>Observations on Acanthometrea</i> .. .. .	503
LOISEL, G.— <i>Senescence and Conjugation in Infusorians</i> .. .. .	503
AYRTON, W.— <i>New Vorticellid</i> .. .. .	504
PALMER, T. CHALKLEY— <i>New Species of Trachelomonas</i> .. .. .	504
CASTELLANI, A.— <i>Trypanosoma found in Sleeping Sickness</i> .. .. .	504
DREYER, GEORGES— <i>Influence of Light on Amœbæ and their Cysts</i> .. .. .	617
PRENANT, A.— <i>Myonemes of Protozoa</i> .. .. .	618
PENARD, E.— <i>Multicilia lacustris Lauterborn</i> .. .. .	618
DANGEARD, P. A.— <i>Observations on Monas vulgaris</i> .. .. .	618
BABES, V.— <i>Parasite of Texas Fever</i> .. .. .	618
CRAWLEY, HOWARD— <i>Myxosporidian Parasite of Geophilus</i> .. .. .	618
ARGUTINSKY, P.— <i>Plasmodium præcox</i> .. .. .	619
VOGES, O.— <i>Parasite of a Central South American Horse Disease</i> .. .. .	619
MUSGRAVE, W. E.— <i>Trypanosomiasis of Horses in the Philippines</i> .. .. .	619
LÉGER, L., & O. DUBOSCQ— <i>Development of Gregarines</i> .. .. .	619
MILLETT, F. W.— <i>Report on the Recent Foraminifera of the Malay Archipelago collected by Mr. A. Durrand, F.R.M.S.—Part XV. (Plate VII.)</i> .. .. .	685
LÉGER, L., & O. DUBOSCQ— <i>Sexual Reproduction of Pteroccephalus</i> .. .. .	729
“ “ <i>New Parasite of Hermit-Crabs</i> .. .. .	730
HOLMES, S. J.— <i>Phototaxis in Volvox</i> .. .. .	730
LÜHE, M.— <i>Progress in Study of Coccidia</i> .. .. .	730

## BOTANY.

## GENERAL,

Including the Anatomy and Physiology of Seed Plants.

## Cytology,

including Cell-Contents.

PAGE

FEINBERG, L.— <i>Nuclei of Unicellular Animals contrasted with those of Plant Cells</i> ..	47
KRAEMER, H.— <i>Continuity of Protoplasm</i> .. .. .	47
ERNST, A.— <i>Nuclear Reduction and Fertilisation in Paris and Trillium</i> .. .. .	48
WESSELINGH, C. VAN— <i>Nucleus of Spirogyra</i> .. .. .	48
CAVARA, F.— <i>Observations on the Nucleolus</i> .. .. .	49
HARDEN, A., & W. J. YOUNG— <i>Glycogen from Yeast</i> .. .. .	49
DONARD, E., & H. LABBÉ— <i>New Proteid from Maize</i> .. .. .	49
LIÉNARD, E.— <i>Reserve Carbohydrates of the Albumen of Palms</i> .. .. .	49
ARCANGELI, A.— <i>Detection of Phosphorus in Plants</i> .. .. .	49
CHEVALIER, AUG.— <i>Caoutchouc-yielding Landolphas of the French Congo</i> .. .. .	49
BAKER, R. T., & H. G. SMITH— <i>Leaf-Venation and Chemical Constituents of Eucalypts</i> .. .. .	50
MAIDEN, J. H.— <i>Gums, Resins, and other Vegetable Exudations of Australia</i> .. .. .	50
WALK, GUSTAV V.— <i>Specific Gravity of Cell-sap</i> .. .. .	186
GAUTIER, ARMAND— <i>Arsenic in Plants and Animals</i> .. .. .	186
RUSSELL, W.— <i>Localisation of Daphnine in Daphne Laureola</i> .. .. .	187
EWART— <i>Protoplasmic Streaming</i> .. .. .	308
PETIT, L.— <i>Distribution of Spherulin among Plant Families</i> .. .. .	309
MOTIER, D. M.— <i>Behaviour of the Chromosomes in the Spore-Mother-Cells of Higher Plants</i> .. .. .	505
GRÉGOIRE & WYGAERTS— <i>Reconstitution and Formation of Chromosomes in Somatic Nuclei</i> .. .. .	505
ROSENBERG, O.— <i>Behaviour of the Chromosomes of Hybrids</i> .. .. .	505
COTTON, W. A.— <i>Behaviour of Nuclei in Plant Hybrids</i> .. .. .	506
NĚMEC— <i>Non-Sexual Nuclear Fusions</i> .. .. .	506
LAWSON, A. A.— <i>Relationship of the Nuclear Membrane to the Protoplast</i> .. .. .	506
SCHRAMMEN, F. R.— <i>Effect of Temperature on Growing Cells</i> .. .. .	507
KRAEMER, H.— <i>Structure of the Starch-Grain</i> .. .. .	507
MATRUCHOT, O., & M. MOLLIARD— <i>Action of Freezing on Plant-Cells</i> .. .. .	508
HUSEK, G.— <i>Starch-Grains in the Root-Cap of the Onion</i> .. .. .	508
FAUST, E. S.— <i>Acocantherin: an African Arrow-Poison</i> .. .. .	508
STEVENS, F. L. & A. C.— <i>Mitosis in Synchytrium</i> .. .. .	620
CHAMRERLAIN, C. J.— <i>Mitosis in Pellia</i> .. .. .	620
LAWSON, A. A.— <i>Studies in Spindle Formation</i> .. .. .	731
FARMER, J. B., & J. E. S. MOORE— <i>Reduction of Chromosomes</i> .. .. .	732
GUTTENBERG, H. V.— <i>Crystal-Cells and the Leaf of Citrus</i> .. .. .	732
HEYL, G.— <i>Alkaloids of Dicentra formosa</i> .. .. .	732

## Structure and Development.

## Vegetative.

LAMARLIÈRE, L. GÉNEAU DE— <i>Conifer Wood from the Turf-Pits</i> .. .. .	50
D'IPOLITO, G.— <i>Comparative Anatomy of the Stem in Magnoliaceæ</i> .. .. .	51
KUSANO, S.— <i>Parasitism of Buckleya Quadrifida</i> .. .. .	51
BEYER, H.— <i>Anatomy of Anonaceæ</i> .. .. .	51
HANSGIRG, A.— <i>Protection of Young Foliage Leaves and Seed Leaves</i> .. .. .	51

	PAGE
CUSHMAN, J. A.— <i>Localised Stages of Growth</i> .. .. .	51
HARRIS, J. A.— <i>Thorns of Gleditschia Triacanthos</i> .. .. .	51
DAGUILLON, A.— <i>Distribution of Hairs on the Surface of the Stem</i> .. .. .	52
GAMBLE, J. S.— <i>Manual of Indian Timbers</i> .. .. .	52
WORSDELL, W. C.— <i>Evolution of Vascular Tissue</i> .. .. .	187
GOLDEN, K. E.— <i>Histology of the Wood in Species of Pines</i> .. .. .	188
ENDRISS, W.— <i>Pilostyles Ingæ</i> .. .. .	188
SCHOUTE, J. C.— <i>Stelar System in Flowering Plants</i> .. .. .	309
VUILLEMIN, P.— <i>Intermediate Wood</i> .. .. .	309
RODRIGUE, A.— <i>Anatomy and Movements of Portiera hygrometrica</i> .. .. .	310
FLOT, LÉON— <i>Foliar Origin of the Stem</i> .. .. .	508
COL, M.— <i>Bundle Arrangement in the Petiole and Leaf-Veins in Dicotyledons</i> .. .. .	509
BOUYGUES, M.— <i>Existence of a Pith in the Leaf-Stalk of Phanerogams</i> .. .. .	509
QUEVA, C.— <i>Unipolar Stele in Rootlets of Trapa</i> .. .. .	509
JOESTING, F.— <i>Anatomy of certain Groups of Caryophyllaceæ</i> .. .. .	510
THOUVENIN, M.— <i>Petiolar Glands of Viburnum Opulus</i> .. .. .	510
DANIEL, L.— <i>Modification of Habit by Grafting</i> .. .. .	510
"    "    " <i>Experiments on Grafted Plants</i> .. .. .	511
ESTEVA, J.— <i>Abnormal Growths in Woody Plants</i> .. .. .	511
CHICK, EDITH— <i>Seedling of Torreya Myristica</i> .. .. .	621
KÜSTER, E.— <i>Pathological Plant-Anatomy</i> .. .. .	621
CHAUVEAUD, G.— <i>New Secretory Apparatus in Conifers</i> .. .. .	621
BIBLIOGRAPHY .. .. .	622
MATTE, H.— <i>Meriphyte of the Cycads</i> .. .. .	733
IRGANG, G.— <i>Sap-secreting Elements in Tropæolum majus</i> .. .. .	733
PISCHINGER, F.— <i>Regeneration of the Assimilating Mechanism in Streptocarpus and Monophyllæa</i> .. .. .	733
BIBLIOGRAPHY .. .. .	734

## Reproductive.

WAGNER, R.— <i>Lagochilus</i> .. .. .	52
BARSANTI, L.— <i>Cause of Floral Zygomorphism</i> .. .. .	52
CLOS, D.— <i>Theory of the Petiole in the Flower</i> .. .. .	52
DOP, PAUL— <i>Development of Pollen in Asclepiads</i> .. .. .	53
RICHER, P. P.— <i>Germination of Pollen-Grains</i> .. .. .	53
GUIGNARD, L.— <i>Double Fertilisation in Crucifers</i> .. .. .	53
CAMPBELL, D. H.— <i>Recent Investigations in the Embryo-sac of Angiosperms</i> .. .. .	53
SCHMID, B.— <i>Development of the Embryo of some Dicotyledons</i> .. .. .	188
LAND, W. G.— <i>Morphological Study of Thuja</i> .. .. .	189
MENNECHET, L. A.— <i>Fruit of Jacquinia ruscifolia and Trichomes in Myrsinaceæ</i> .. .. .	189
COULTER, J. M., & C. J. CHAMBERLAIN— <i>Embryogeny of Zamia</i> .. .. .	310
MURBECK, SV.— <i>Life-History of Ruppia</i> .. .. .	311
REED, H. S.— <i>Development of Macrosporangium of Yucca</i> .. .. .	312
TREUB, M.— <i>Embryogeny of Ficus hirta</i> .. .. .	313
BILLINGS, F. H.— <i>Chalazogamy in Carya olivæformis</i> .. .. .	313
HOCHREUTNER, B. P. G.— <i>Biology of Fruit in Malvaceæ</i> .. .. .	313
NICGLOFF, TH.— <i>Floral Structure of Juglandææ</i> .. .. .	314
JOHNSON, D. S.— <i>Development in Piperaceæ</i> .. .. .	511
FRYE, T. C.— <i>Morphological Study of Asclepiadaceæ</i> .. .. .	512
RENAULT, B.— <i>Vegetative Activity in the Carboniferous Epoch</i> .. .. .	513
WAGNER, R.— <i>Notes on Compositæ</i> .. .. .	513
BORZI, A.— <i>Seeds of Inga</i> .. .. .	513
GRÉLOT, P.— <i>Laticiferous Tissue in Flowers of Convolvulaceæ</i> .. .. .	513
OLIVER, F. W.— <i>Lagenostoma Lomaxi, the Seed of Lyginodendron</i> .. .. .	622
GUERIN, J.— <i>Development and Structure of the Seed-Cout in Gentianaceæ</i> .. .. .	622
WORSDELL, W. C.— <i>Abnormal Flowers of Helenium autumnale</i> .. .. .	623
BIBLIOGRAPHY .. .. .	623
COKER, W. C.— <i>Gametophytes and Embryo of Taxodium</i> .. .. .	734
MORPHOLOGY OF Angiosperms .. .. .	735
JUEL, H. O.— <i>Development of the Ovule in Casuarina</i> .. .. .	736
LAURENT, M.— <i>Formation of the Egg and Division of an Antipodal Cell in the Juncaceæ</i> .. .. .	736
BIBLIOGRAPHY .. .. .	737

## Physiology.

## : Nutrition and Growth.

	PAGE
BERNARD, NOEL— <i>Physical Conditions of Tuberculosis in Plants</i> .. .. .	54
GRIFFIN, E., & R. O. HERZOG— <i>Photosynthesis</i> .. .. .	54
BOKORNY, TH.— <i>Assimilation of Yeasts</i> .. .. .	55
CHAPIN, P.— <i>Influence of Carbonic Acid Gas on Growth</i> .. .. .	189
CZAPEK, F.— <i>Nitrogen Assimilation in Moulds</i> .. .. .	190
DORNER, H. B.— <i>Effect of Composition of Soil on Plants</i> .. .. .	190
SABLON, LECLERO DU— <i>Variation in Carbohydrate Reserves in Stem and Root of Woody Plants</i> .. .. .	191
MACCHIATI, L.— <i>Photosynthesis outside the Plant</i> .. .. .	314
MAZÉ, P.— <i>Ripening of Seeds and the Power of Germination</i> .. .. .	315
DANDENO, J. B.— <i>Effects of Water and Aqueous Solutions on Foliage Leaves</i> .. .. .	315
BOUILHAC, R.— <i>Formic Aldehyde as a Food-stuff for Fresh-water Algæ</i> .. .. .	316
LAURENT, EM., & EM. MARCHAL— <i>Synthesis of Proteids by Plants</i> .. .. .	513
POLLACCI, G.— <i>Assimilation in Green Plants</i> .. .. .	514
BUSCALIONI, L., & G. POLLACCI— <i>Use of Collodion for Detecting Transpiration</i> .. .. .	514
AMAR, M.— <i>Function of Calcium Oxalate in Plant Nutrition</i> .. .. .	515
TAMMES, TINE— <i>Periodicity of Morphological Phenomena in Plants</i> .. .. .	515
CHICK, HARRIETTE, & P. G. CHARPENTIER— <i>Nitrogenous Metabolism in Minute Algæ</i> .. .. .	623
ANDRÉ, G.— <i>Nutrition of Plants deprived of their Cotyledons</i> .. .. .	624
BIBLIOGRAPHY .. .. .	624
LUTZ, L.— <i>Alkaloids as a Source of Nitrogen</i> .. .. .	737
HÉBERT, A., & G. TRUFFAUT— <i>Nutrition of Chrysanthemums</i> .. .. .	737
BERNARD, N.— <i>Germination of Orchids: a Symbiotic Relationship</i> .. .. .	737

## Irritability.

HEINRICHER, E.— <i>Influence of Light on Seed-Germination</i> .. .. .	55
FLOWMAN, A. B.— <i>Relations of Plant-Growth to Ionisation</i> .. .. .	56
ROBERTSON, R. A.— <i>Functional Inertia of Plant-Protoplasm</i> .. .. .	191
BURGSTEIN, A.— <i>Movement of Perianth Leaves of Tulip and Crocus</i> .. .. .	191
NEWCOMBE, F. C.— <i>Thigmotropic Root-Curvatures</i> .. .. .	192
WIEDERSHEIM, W.— <i>Influence of Loading on the Formation of Wood and Bast Elements in Weeping Trees</i> .. .. .	192
MACDOUGAL, D. T.— <i>Influence of Light and Darkness on Plant-life</i> .. .. .	316
TRAVERSO, G. B.— <i>Stomata of Cotyledons</i> .. .. .	515
DARWIN, F.— <i>Statolith Theory of Geotropism</i> .. .. .	515
DIXON, H. H.— <i>Resistance of Seeds to High Temperatures</i> .. .. .	624
BIBLIOGRAPHY .. .. .	624
JURIE, A.— <i>Morphological Variation in Leaves of the Vine as a consequence of Grafting</i> .. .. .	738

## Chemical Changes.

NEWTON, G. R.— <i>Enzyme in Ripening Plantains</i> .. .. .	56
BOKORNY, TH.— <i>Yeast Ferment</i> .. .. .	56
MUYNCK, A. DE— <i>Sugar in Ripe Fruits</i> .. .. .	192
SUZUKI, U.— <i>Formation of Asparagine in Metabolism</i> .. .. .	192
ASO, K.— <i>Lime in Phanerogamic Parasites</i> .. .. .	192
SUZUKI, U.— <i>Composition of Seeds of Ginkgo biloba</i> .. .. .	193
BALICKA-IWANOWSKA, GABRIELLE— <i>Decomposition and Regeneration of Albuminoids in Plants</i> .. .. .	317
CHODAT, R., & A. BACH— <i>Function of Peroxides in the Living Cell</i> .. .. .	317
POLLACCI, G.— <i>Hydrogen and Carburetted Hydrogen formed by Plants</i> .. .. .	516
BRÉAL, E.— <i>Experiments with Potatoes</i> .. .. .	516
VERSCHAFFELT, E.— <i>Prussic Acid in Opening Buds of Prunus</i> .. .. .	516
SLADE, H. B.— <i>Hydrocyanic Acid in Sorghum</i> .. .. .	517
KELLERMAN, K. F.— <i>Effects of Chemical Agents on the Starch-converting Power of Taka Diastase</i> .. .. .	517

	PAGE
BOURQUELOT, EM.— <i>Hydrolysis of Polysaccharides</i> .. .. .	517
LITTMANN, E. O. VON— <i>Nomenclature of Enzymes</i> .. .. .	518
WEEVERS, TH.— <i>Changes in Salicin in Plant Nutrition</i> .. .. .	518
TAKAHASHI, T.— <i>Production of Alcohol in Seeds</i> .. .. .	518
LOEW, O.— <i>Action of Uranium on Plants</i> .. .. .	518
ASO, K., & S. SUZUKI— <i>Action of Sodium Fluoride and Potassium Iodide and Potassium Ferrocyanide on Plants</i> .. .. .	518
BOKORNY, TH.— <i>Nature of Protoplasm and Enzymes</i> .. .. .	624
JAVILLIER, M.— <i>Proteolytic Ferments</i> .. .. .	625

## General.

PERKINS, JANET— <i>Notes on Styraceæ</i> .. .. .	57
.. .. . <i>Revision of the Species of Lisianthus</i> .. .. .	57
CHEVALIER, AUG.— <i>Monograph of the Myricaceæ</i> .. .. .	57
JACCARD, P.— <i>Floral Distribution in the Alpine Zone</i> .. .. .	57
PODPERA, J.— <i>Plant-Formations and Flora of South Bulgaria</i> .. .. .	57
MASTERS & W. T. THISELTON-DYER— <i>Chinese Flora</i> .. .. .	57
ARECHAVALETA, J.— <i>Flora of Uruguay</i> .. .. .	57
GREENMAN, J. M.— <i>Monograph of North and Central American Species of Senecio</i> .. .. .	57
CAMBAGE, R. H., AND OTHERS— <i>Notes on Australian Botany</i> .. .. .	57
PENZIG, O.— <i>Plant Teratology</i> .. .. .	58
ZIMMERMANN, C.— <i>Plant Microscopy</i> .. .. .	58
FORBES & HEMSLEY— <i>Chinese Flora</i> .. .. .	193
HARSHBERGER, J. W.— <i>Strand Flora of New Jersey</i> .. .. .	193
VAYREDA— <i>Plants of Catalonia</i> .. .. .	318
AFRICAN Flora XXIV. .. .. .	318
PLATEAU, F.— <i>Poppies and Insect Visitors</i> .. .. .	518
CORRENS— <i>Determination of Dominance in the Colour Characters of Hybrids</i> .. .. .	519
MONTEMARTINI, L.— <i>Aristolochiaceæ</i> .. .. .	519
SCHUTE, TH., & K. W. VON DALLA TORRE— <i>German Flora</i> .. .. .	519
WRIGHT, C. H.— <i>Flora of China</i> .. .. .	519
MAIDEN, J. H.— <i>Plants of Lord Howe Island</i> .. .. .	519
PINCHOT, G.— <i>Forest Destruction in the United States</i> .. .. .	520
POWER, F. B., & P. E. F. PERRÉDÈS— <i>Poisonous Action and Histology of Stem of <i>Derris uliginosa</i></i> .. .. .	520
BUSCALIONI, L.— <i>Mercerisation of Cotton Fabrics</i> .. .. .	520
COULTER, J. M.— <i>Origin of Angiosperms</i> .. .. .	625
SMITH, WINIFRED— <i>Myrmecophily in <i>Macaranga triloba</i></i> .. .. .	625
SCHULZ, O. E.— <i>Monograph of the Genus <i>Cardamine</i></i> .. .. .	626
AFRICAN Flora .. .. .	626
BORNMÜLLER, I.— <i>Flora of Ferio</i> .. .. .	626
VERRILL, A. E.— <i>Bermuda Islands</i> .. .. .	626
MICHELLI, M.— <i>Mexican Leguminosæ</i> .. .. .	626
HUBER, T.— <i>Amazon Flora</i> .. .. .	626
BIBLIOGRAPHY .. .. .	627
BERRY, E. W.— <i>American Species of <i>Thunfeldia</i></i> .. .. .	738
NASH, G. V.— <i>Revision of the Family <i>Fouquieriaceæ</i></i> .. .. .	738
CORRENS, C.— <i>On the Characters of Hybrids</i> .. .. .	739
LOVELL, J. H.— <i>Colours of Northern Gamopetalous Flowers</i> .. .. .	739
PARKIN, J., & H. H. W. PEARSON— <i>Botany of the Ceylon Patanas</i> .. .. .	739
BIBLIOGRAPHY .. .. .	740

## CRYPTOGAMS.

## Pteridophyta.

DAVENPORT, G. E., & OTHERS— <i>Fern Study in North America</i> .. .. .	58
UNDERWOOD, L. M., & W. R. MAXON— <i>Cuban Ferns</i> .. .. .	58
SCOTT, D. H.— <i>Primary Structure of certain Palæozoic Stems</i> .. .. .	193
STEINBRINCK, C.— <i>Permeability of Cell-walls to Air</i> .. .. .	194
MAXON, W. R., & L. M. UNDERWOOD— <i>Ferns and Fern Allies of North America</i> .. .. .	195
BENNETT, A.— <i>Equisetum hyemale</i> .. .. .	195

	PAGE
BOWER, F. O.— <i>Morphology of Spore-producing Members: General Comparisons and Conclusion</i> .. .. .	320
UNDERWOOD, L. M.— <i>Botrychium</i> .. .. .	320
CCKER, W. C.— <i>Spore-cavity Nucleus in Prothallia of Marsilia</i> .. .. .	320
SCHWENDENER, S.— <i>Opening Mechanism of the Macrosporangia of Selaginella</i> ..	321
LEAVITT, R. G.— <i>Root-Development in Azolla</i> .. .. .	520
POOLE, H. S.— <i>Stigmaria</i> .. .. .	521
LUERSEN, C.— <i>German Pteridophyta</i> .. .. .	521
CLUTE, W. N., & OTHERS— <i>North American Pteridophyta</i> .. .. .	521
FARMER, J. B., & OTHERS— <i>Cytology of Apogamy</i> .. .. .	740
YABE, Y., & OTHERS— <i>East Asiatic Pteridophyta</i> .. .. .	740
MAXON, W. R., & OTHERS— <i>North American Pteridophyta</i> .. .. .	741

## Bryophyta.

QUELLE, F.— <i>Rhizoid-Initials of Marchantia</i> .. .. .	58
CORBIÈRE, L.— <i>Riella</i> .. .. .	59
LETT, H. W.— <i>British Hepatics</i> .. .. .	59
MÜLLER, K.— <i>Hepatics of Baden</i> .. .. .	59
EVANS, A. W., & OTHERS— <i>North American Hepatics</i> .. .. .	59
SALMON, E. S.— <i>New Zealand Hepatics</i> .. .. .	59
BERGEVIN, E. DE— <i>Interconversion of Sexual Organs in a Moss</i> .. .. .	59
GROUT, A. J.— <i>Peristome</i> .. .. .	60
GEHEB, A.— <i>Suppression of Redundant Moss-Species</i> .. .. .	60
KINDBERG, N. C.— <i>Genus Thamnium</i> .. .. .	60
SALMON, E. S.— <i>Notes on Oculatia and Schwetschka</i> .. .. .	60
WHELDON, J. A., & OTHERS— <i>British Moss Flora</i> .. .. .	60
CAMUS, F., & OTHERS— <i>French Moss Flora</i> .. .. .	61
LAMARLIÈRE, L. GÉNEAU DE— <i>Moss Flora of French Caverns</i> .. .. .	61
CYPERS, V. V.— <i>German Mosses</i> .. .. .	61
PARIS, E. G.— <i>Japanese Mosses</i> .. .. .	61
.. .. . <i>Muscineæ of South-East Asia</i> .. .. .	61
EVANS, A. W., & W. G. FARLOW— <i>Muscineæ of the Galapagos Islands</i> .. .. .	62
SCHIFFNER, V.— <i>Muscineæ of the Atlantic Islands</i> .. .. .	62
IKENO, S.— <i>Formation of Antherozoids in Marchantia</i> .. .. .	321
BENECKE, W.— <i>Culture of Hepatics</i> .. .. .	321
MASSALONGO, C.— <i>Scapania</i> .. .. .	321
DOUIN, I.— <i>Papillate Hepatics</i> .. .. .	322
CORBIÈRE, L.— <i>Fossombronina</i> .. .. .	322
WARNSTORF, C.— <i>German Hepatics and Sphagna</i> .. .. .	322
BARSALI, E., & C. MASSALONGO— <i>Italian Hepatics</i> .. .. .	322
HAYNES, C. C.— <i>American Hepatics</i> .. .. .	322
BARBOUR, W. C.— <i>Lejeunea in North America</i> .. .. .	322
EVANS, A. W.— <i>Hepaticæ of Puerto Rico</i> .. .. .	323
COKER, W. C.— <i>Two Egg-Cells in Mnium</i> .. .. .	323
BRAITHWAITE, R.— <i>British Mosses</i> .. .. .	323
INGHAM, W.— <i>Yorkshire Muscineæ</i> .. .. .	323
BAGNALL, J. E.— <i>Ricciocarpus natans</i> .. .. .	323
CROZALS, A.— <i>French Volcanic Muscineæ</i> .. .. .	323
HERZOG, TH.— <i>European Mosses</i> .. .. .	323
ROLL, J., & OTHERS— <i>German Mosses</i> .. .. .	323
MATOSCHEK, F.— <i>Austrian Muscineæ</i> .. .. .	324
BOTTINI, A.— <i>Italian Mosses</i> .. .. .	324
KINDBERG, N. C.— <i>North American Mosses</i> .. .. .	324
CARDOT, J., & OTHERS— <i>Mosses of Alaska</i> .. .. .	324
HOLZINGER, J. M.— <i>Inconspicuous Mosses</i> .. .. .	325
WILLIAMS, R. S.— <i>Psilopilum</i> .. .. .	325
DUSÉN, P.— <i>Mosses of East Greenland</i> .. .. .	325
THE MOSS EXCHANGE CLUB— <i>Report for 1903</i> .. .. .	325
SCHIFFNER, V., & J. M. HOLZINGER— <i>K. G. Limpricht</i> .. .. .	325
CAVERS, F., & OTHERS— <i>Ejection of Antherozoids</i> .. .. .	521
GRIMME, A.— <i>Fertilisation and Spore-Ripening in Mosses</i> .. .. .	522
HOWE, M. A., & L. M. UNDERWOOD— <i>Riella</i> .. .. .	522

	PAGE
DOUIN, I.— <i>Sphaerocarpus terrestris</i> .. .. .	522
M CARDLE, D., & H. W. LETT— <i>Irish Hepatics</i> .. .. .	523
HORRALL, E. C., & D. A. JONES— <i>Sphagna of Upper Teesdale</i> .. .. .	523
CASARES-GIL, A.— <i>Homalia lusitânica</i> .. .. .	523
KRIEGER— <i>Catharinaea</i> .. .. .	523
DIXON, H. N.— <i>Dichodontium</i> .. .. .	523
KINDBERG, N. C.— <i>Anomolon Toccoæ</i> .. .. .	523
STIRTON, J., & OTHERS— <i>British Mosses</i> .. .. .	523
OSTERWALD, K., & O. JAAP— <i>German Muscineæ</i> .. .. .	524
BOTTINI, A.— <i>Italian Mosses</i> .. .. .	524
GROUT, A. J., & OTHERS— <i>North American Mosses</i>	524
WATTS, W. W., & T. WHITELEGGE— <i>Moss Flora of Australia</i> .. .. .	524
VAUPEL, F.— <i>Morphology of Muscineæ</i> .. .. .	627
PAUL, H.— <i>Rhizoids of Mosses</i> .. .. .	627
BEER, E.— <i>Chromosomes of Funaria hygrometrica</i>	628
ROTH, G.— <i>European Mosses</i> .. .. .	628
GROUT, A. J.— <i>American Mosses</i> .. .. .	628
CAVERS, F.— <i>Asexual Reproduction</i> .. .. .	628
.. .. . <i>Biology of Hepaticæ</i> .. .. .	629
IKENO— <i>Development of Spermatozoids in Marchantia</i>	741
LIMPRICHT, W., & OTHERS— <i>European Mosses</i>	741
NICHOLSON, W. E.— <i>Weisia sterilis</i> sp. n. .. .. .	742
KINDBERG, N. C.— <i>Thamnum</i> .. .. .	742
BRITTON, E. G., & OTHERS— <i>American Mosses</i>	742
PARIS, E.— <i>West African Mosses</i> .. .. .	742
STABLER, G.— <i>British Hepaticæ</i> .. .. .	742
DOUIN, I., & OTHERS— <i>European Hepaticæ</i> .. .. .	742
SCHIFFNER, V.— <i>Gymnomitrium and Marsupella</i> .. .. .	743
EVANS, A. W.— <i>North American Hepaticæ</i> .. .. .	743
BIBLIOGRAPHY .. .. .	743

## Mosses.

WARNSTORF, C.— <i>European Harpidia</i> .. .. .	195
SALMON, E. S.— <i>Streptopogon</i> .. .. .	196
.. .. . <i>Calyptopogon</i> .. .. .	196
BRITTON, E. G.— <i>Sematophyllum in North America</i> .. .. .	196
GROUT, A. J.— <i>Orthotrichum in the United States</i> .. .. .	196
HENNINGS, P.— <i>Microthamnium</i> .. .. .	197
LORCH, W.— <i>Leaf-cells of Sphagnum</i> .. .. .	197
SCHIFFNER, V., & A. CASARES GIL— <i>European Muscineæ</i>	197
.. .. . <i>Muscineæ of the Atlantic Islands</i> .. .. .	197
MACVICAR, S. M., & OTHERS— <i>British Hepaticæ</i> .. .. .	198
MÜLLER, K., & A. HOLLER— <i>European Hepaticæ</i> .. .. .	198
LIMPRICHT, W., & OTHERS— <i>European Mosses</i> .. .. .	198
KELLER, R.— <i>Mosses of Central Switzerland</i> .. .. .	199
FISCHER, F.— <i>Swiss Cryptogams</i> .. .. .	199

## Thallophyta.

## Algæ.

BLACKMAN, V. H.— <i>The Pyrocystæ</i> .. .. .	62
MERLIN, A. A.— <i>Minute Structure in Triceratium</i> .. .. .	62
FRITSCH, F. E.— <i>Phytoplankton of the Thames</i> .. .. .	63
VOGLER, P.— <i>Variations-Statistics as applied to Plankton-Diatoms</i>	63
MILLS, F. W., & R. H. PHILIP— <i>Diatomaceæ of the Hull District</i> .. .. .	63
MERESCHKOWSKY, C.— <i>Limosphenia, a New Genus of Diatoms</i>	64
KUCKUCK, P.— <i>Reproduction of Valonia</i> .. .. .	64
ERNST, A.— <i>A New Genus of Siphonæ</i> .. .. .	64
LÜTKEMÜLLER, J.— <i>Cell-Membrane of Desmidiaceæ</i> .. .. .	65
HAZEN, T. E.— <i>Ultrichaceæ and Charophoraceæ of the United States</i>	65

	PAGE
FRITSCH, F. E.— <i>Edogonium</i> .. .. .	66
TOBLER, F.— <i>Vegetative Reproduction of Dasys elegans</i> .. .. .	66
HEYDRICH, F.— <i>New Genus of Delesseriaceæ</i> .. .. .	66
SCHWENDENER, S.— <i>Spiral Arrangement in Floridæ</i> .. .. .	66
HOWE, MARSHALL A.— <i>Cnloglossa Leprieurii</i> .. .. .	66
BATTERS, E. A. L.— <i>Catalogue of British Marine Algæ</i> .. .. .	66
BÖRGESEN, F.— <i>Marine Algæ of the Faeroes</i> .. .. .	67
SVEDELIUS, NILS— <i>Marine Algæ from Dago</i> .. .. .	67
SAUVAGEAU, CAMILLE— <i>Australasian Sphaclariæ</i> .. .. .	67
FARLOW, W. G.— <i>Algæ of the Galapagos Islands</i> .. .. .	67
LAING, R. M.— <i>New Zealand Marine Algæ</i> .. .. .	68
KESSLER, CARL VON— <i>Plankton of the Alt-Ausseeer Lake</i> .. .. .	199
MERESCHKOWSKY, C.— <i>Diatoms of the Black Sea</i> .. .. .	199
PANTOCSEK, J.— <i>Hungarian Diatoms: Lake Balaton</i> .. .. .	200
MERESCHKOWSKY, C.— <i>Pyrenoids and Elaeoplasts in Diatoms</i> .. .. .	200
LANZI, MATTEO— <i>Fossil Diatoms in Rome</i> .. .. .	200
"   " <i>Diatoms of Lake Cotronia</i> .. .. .	200
BOHLIN, KNUT— <i>Centronella and Phæodactylon</i> .. .. .	200
WEST, W.— <i>Debarya immersa</i> West .. .. .	201
BESSEY, CHARLES E.— <i>Conjugatæ</i> .. .. .	201
FRITSCH, F. E.— <i>Fresh-water Algæ of the Royal Gardens, Kew</i> .. .. .	201
"   " <i>Young Plants of Stigeoclonium</i> .. .. .	201
HEYDRICH, F.— <i>New Genus of Valoniaceæ</i> .. .. .	201
"   " <i>Melobesizæ</i> .. .. .	202
HOLTZ, L.— <i>Characeæ of Mark Brandenburg</i> .. .. .	202
WEST, W. & G. S.— <i>Fresh-water Algæ of the North of Ireland</i> .. .. .	202
BATTERS, E. A. L.— <i>Scottish Algæ</i> .. .. .	203
GUTWIŃSKI, R.— <i>Javan Algæ</i> .. .. .	203
WHITE, D.— <i>Fossil Algæ</i> .. .. .	203
COMÈRE, J.— <i>Action of Salt Water on certain Fresh-water Algæ</i> .. .. .	203
WEST, W. & G. S.— <i>British Fresh-water Algæ</i> .. .. .	326
HANSGIRG, A.— <i>Fresh-water Algæ</i> .. .. .	326
GAIDUKOW, N.— <i>Literature on the Algal Flora of Russia</i> .. .. .	326
BOHLIN, K.— <i>Fresh-water Algæ of the Azores</i> .. .. .	326
SCHMIDLE, W.— <i>Plankton of Lake Nyassa</i> .. .. .	327
WILLE, N.— <i>Fresh-water Algæ from Zambesi</i> .. .. .	327
USHMAN, J. A.— <i>Desmidiæ from Bridgewater (Mass.)</i> .. .. .	327
COLLINS, F. S.— <i>North American Marine Algæ</i> .. .. .	327
BORGE, O.— <i>Fresh-water Algæ from South Patagonia</i> .. .. .	327
GRINTZESCO, J.— <i>Cultivation of Chlorella vulgaris</i> .. .. .	328
LÜTKEMÜLLER, J.— <i>Cell-membrane of Desmidiaceæ</i> .. .. .	328
ERNST, A.— <i>Dichotomosiphon tuberosus</i> .. .. .	329
WRIGHT, E. PERCEVAL— <i>Bryopsis plumosa</i> .. .. .	329
"   " <i>Mastogloia fimbriata and M. binotata</i> .. .. .	329
SKOTTSSBERG, C.— <i>Macrocystis pyrifera</i> .. .. .	329
YENDO, K.— <i>Eisenia and Ecklonia</i> .. .. .	329
OKAMURA, K.— <i>Vegetative Reproduction in Chondria crassicaulis</i> .. .. .	330
FORTI, A.— <i>Fresh-water Diatoms</i> .. .. .	330
OSTENFELD, C. H., & E. OESTRUP— <i>Diatoms of Koh Chang</i> .. .. .	330
MOLISCH, H.— <i>Blue Diatom</i> .. .. .	330
MERESCHKOWSKY, C.— <i>Classification of Diatoms</i> .. .. .	331
"   " <i>Polynesian Diatoms</i> .. .. .	331
TOBLER, F.— <i>Germination of certain Floridæ</i> .. .. .	331
KUCKUCK, P., & OTHERS— <i>German Algæ and Peridiniæ</i> .. .. .	524
GRINTZESCO, J.— <i>Morphology and Physiology of Scenedesmus acutus</i> .. .. .	525
ROWLEY, F. R.— <i>Structure and Life-History of Diatoms</i> .. .. .	525
HÉRIBAUD, F.— <i>Fossil Diatoms of Auvergne</i> .. .. .	525
SMITH, A.— <i>Lincolnshire Diatoms</i> .. .. .	526
BROWN, R. N. RUDMOSE— <i>Atlantic Plankton</i> .. .. .	526
SCHMIDLE, W.— <i>Plankton of Lake Nyassa and other Mid-African Lakes</i> .. .. .	526
REINKE, J.— <i>Studies on the Comparative Development of Laminariaceæ</i> .. .. .	526
MIYABÉ, KINGO— <i>Laminariaceæ and Laminaria Industries of Hokkaido, Japan</i> .. .. .	527



	PAGE
IIENCKEL, A.— <i>Cystoclonium purpurascens</i> and <i>Chordaria flagelliformis</i> .. .. .	527
MAZZA, A.— <i>Schimmelmanni ornata</i> .. .. .	527
SETCHELL, W. A., & N. L. GARDNER— <i>Algæ of North-Western America</i> .. .. .	527
JONSSON, H.— <i>Marine Algæ of Iceland</i> .. .. .	528
SCHMIDLE, W.— <i>Fresh-water Algæ</i> .. .. .	629
HILLESHEIM, CATHERINE— <i>Nuclear Stains for Fresh-water Algæ</i> .. .. .	630
CROSBY, CAROLINE M.— <i>Dietyosphaeria favulosa</i> .. .. .	630
BRAND, C. J.— <i>Stapfia cylindrica</i> .. .. .	630
WILLE, N.— <i>Algological Notes</i> .. .. .	630
BASTIAN, H. C.— <i>Spores of Vaucheria</i> .. .. .	631
LILLEY, G.— <i>Nitella batrachosperma</i> .. .. .	631
BASTIAN, H. CHARLTON— <i>Chlorochytrium</i> .. .. .	631
MERESCHKOWSKY, C.— <i>Structure and Division of Diatoms</i> .. .. .	632
"    " <i>Aucospores of Diatoms</i> .. .. .	632
"    " <i>Endochrome of Diatoms</i> .. .. .	635
MÜLLER, O.— <i>Melosira</i> .. .. .	633
BACHMANN, H.— <i>Cyclotella bodanica</i> var. <i>lemanica</i> .. .. .	634
HÉRIBAUD, J.— <i>Diatoms of Auvergne</i> .. .. .	634
MURRAY, G.— <i>Diatoms of the Atlantic</i> .. .. .	634
REICHELT, H., & OTHERS— <i>Fossil Diatoms</i> .. .. .	635
PHILIP, R. H., & OTHERS— <i>Diatom Records</i> .. .. .	635
RAMALEY, F.— <i>Egregia Menziesii</i> .. .. .	635
HOLTZ, F. L.— <i>Pelvetia fastigiata</i> .. .. .	636
SCHRADER, H. F.— <i>New Alaria</i> .. .. .	636
TOBLER, F.— <i>Polymorphism of Marine Algæ</i> .. .. .	636
HEYDRICH, F.— <i>New Iridodermis</i> .. .. .	636
TOBLER, F.— <i>Reparation of Injury in Ceramiaceæ</i> .. .. .	637
BUTTERS, F. K.— <i>Trichogloea lubrica</i> .. .. .	637
MAZZA, A.— <i>New Nitophyllum</i> .. .. .	637
BENTIVOGLIO, T.— <i>Galaxaura adriatica</i> Zan. .. .. .	637
TONI, J. B. DE— <i>Floridex</i> .. .. .	638
SPINELLI, V.— <i>Marine Algæ of Sicily</i> .. .. .	638
AMBERG, O., & OTHERS— <i>Fresh-water Algæ of certain Lakes</i> .. .. .	638
SKINNER, S. A.— <i>Tide-Pool Vegetation</i> .. .. .	639
MAZZA, ANGELO— <i>Algæ of the Gulf of Naples</i> .. .. .	639
GUTWINSKI, R.— <i>Algæ from Central Asia and China</i> .. .. .	639
WHITE, D.— <i>Fossil Algæ of North America</i> .. .. .	639
DAVIS, B. M.— <i>Origin of the Sporophyte</i> .. .. .	640
BÖRGESEN, F.— <i>Marine Algæ of the Shetlands</i> .. .. .	743
BÖRGESEN, F., & C. H. OSTENFELD— <i>Phytoplankton of Lakes in the Faerøes</i> .. .. .	744
OKAMURA, K.— <i>Japanese Marine Algæ</i> .. .. .	744
MERESCHKOWSKY, C.— <i>New Genera of Diatoms</i> .. .. .	744
BELLOC, E.— <i>Diatoms from Morocco</i> .. .. .	744
BIBLIOGRAPHY .. .. .	744

## Fungi.

RUHLAND, W.— <i>Fertilisation in the Phycomycetes</i> .. .. .	68
TURQUET, J.— <i>Amylomyces Rouxii</i> .. .. .	68
HIRSCHBRUCH, ALBERT— <i>Sprouting of Yeast-Cells</i> .. .. .	68
GUILLERMOND, M. A.— <i>Spore-formation in Yeast</i> .. .. .	68
ODIN, G.— <i>Origin of Yeast</i> .. .. .	68
MARFMANN— <i>Cell-Nucleus of Saccharomycetes and Bacteria</i> .. .. .	68
TASSI, F.— <i>New Sphaeropsidex</i> .. .. .	69
JUEL, H. O.— <i>Development of Dipodascus albidus</i> .. .. .	69
GLUCK, H.— <i>Nectria moschata</i> .. .. .	69
HILL, H.— <i>Cordiceps Robertsii</i> .. .. .	69
MAGNUS, P.— <i>Gooseberry Mildew</i> .. .. .	69
DELACROIX, G.— <i>Diseases of the Vanilla</i> .. .. .	70
"    " <i>Disease of Bananus</i> .. .. .	70
THAXTER, ROLAND— <i>Laboulbeniaceæ</i> .. .. .	70

	PAGE
BOISTEL, A.— <i>New French Lichen Flora</i> .. .. .	70
LICHEN <i>Flora of the Tyrol</i> .. .. .	70
MORTEO, E.— <i>Rare Lichen from Liguria</i> .. .. .	70
STEINER, J.— <i>Lichen Flora of Algiers</i> .. .. .	71
HARRIS, C. W.— <i>Umbilicaria in N. America</i> .. .. .	71
ZAHLBRUCKNER, A.— <i>Californian Lichens</i> .. .. .	71
BRIZI, V.— <i>Perforation of Vine-Leaves</i> .. .. .	71
"    " <i>New Parasitic Botrytis</i> .. .. .	71
MCALPINE, D.— <i>Black Spot of the Apple</i> .. .. .	71
MASSEE, G.— <i>Diseased Pelargoniums</i> .. .. .	71
SYDOW, P. & H.— <i>Monograph of the Uredineæ</i> .. .. .	72
ERIKSSON, JAKOB— <i>Specialisation of Rusts</i> .. .. .	72
DELACROIX, G.— <i>Rust on Vanilla</i> .. .. .	72
FREEMAN, E. M.— <i>Experiments on the Brown Rust of Bromes</i> .. .. .	72
FISCHER, E.— <i>Researches on Rusts</i> .. .. .	72
BOUDIER, M. E.— <i>Genus Amanita</i> .. .. .	72
MURRILL, W. A.— <i>North American Polyporeæ</i> .. .. .	72
DUDLEY, P. H.— <i>Lentinus lepidius</i> .. .. .	73
HENNINGS, P.— <i>New Member of the Phalloideæ</i> .. .. .	73
LLOYD, C. G.— <i>Genera of Gastromycetes</i> .. .. .	73
TORREND, C.— <i>Fungi of the Setubal Region</i> .. .. .	73
STRASSER, P. P.— <i>Fungus Flora of Sonntagberg</i> .. .. .	73
FERRARIS, T.— <i>Fungi of Piedmont</i> .. .. .	73
HENNINGS, P., & OTHERS— <i>Japanese Fungi</i> .. .. .	73
LLOYD, C. G.— <i>Notes on American Fungi</i> .. .. .	74
MCALPINE— <i>Fungus Diseases in Australia</i> .. .. .	74
PAMPALONI, L.— <i>Fossil Fungi</i> .. .. .	74
OUDEMANS, C. A. J. A., & C. J. KONING— <i>Fungus Flora of Humus</i> .. .. .	74
COOKE, M. C.— <i>Pests of the Flower Garden</i> .. .. .	75
FREEMAN, E. M.— <i>Seed-Fungus of Lolium temulentum</i> .. .. .	75
ARKÖVY, JOSEF— <i>Leptothrix racemosa</i> .. .. .	75
HARSHBERGER, JOHN W.— <i>Fungous Diseases of White Cedar</i> .. .. .	75
FALCK, RICHARD— <i>Oidium Production and the Culture of the Higher Fungi</i> .. .. .	75
OUDEMANS, C. A. J. A.— <i>Critical Notes</i> .. .. .	76
GILLOT, X.— <i>Sap of Fungi as an Antidote to the Venom of Serpents</i> .. .. .	76
ROLAND, LÉON— <i>Photography of Fungi</i> .. .. .	76
TRAVERSO, G. B.— <i>Sclerospora</i> .. .. .	204
MAGNUS, P.— <i>Urophyctis bohemia</i> .. .. .	204
HENNEBERG, W.— <i>Research on Amylomyces β</i> .. .. .	204
MATRUCHOT, L.— <i>Biology of Piptocephalis</i> .. .. .	204
GUILLEMOND, A.— <i>Cytology of Yeast</i> .. .. .	205
FEINBERG— <i>Study of Nuclei in Yeast and Animal Cells</i> .. .. .	205
HIRSCHBRUCH, ALBERT, & FRITZ THIBAUT— <i>Yeast</i> .. .. .	205
HANSEN, EMIL CHR.— <i>Life-history of Yeasts</i> .. .. .	205
SALMON, E. S.— <i>Notes on Erysiphaceæ</i> .. .. .	206
BARKER, B. T. P.— <i>Morphology and Development of the Ascocarp in Monascus</i> .. .. .	206
MASSEE, G.— <i>Chatonium Bostrychoides</i> .. .. .	206
MONTEMARTINI, L., & OTHERS— <i>New Parasitic Fungi</i> .. .. .	206
HENNINGS, P., & G. LINHART— <i>Distribution of Plant Diseases</i> .. .. .	207
ABBADO, MICHELE— <i>Allescheria and Cryptovalsa</i> .. .. .	207
ENGELKE, C.— <i>Claviceps purpurea</i> .. .. .	207
BACCARINI, P.— <i>New Hypomyces</i> .. .. .	207
KLEBAHN, H.— <i>Study of Related Forms</i> .. .. .	207
GUÉGUEN, F.— <i>Glaeosporium phomoides</i> .. .. .	208
NORTON, J. B. S.— <i>Monilia fructigena</i> .. .. .	208
SMITH, A. LORRAIN— <i>Sclerotinia Fuckeliana</i> .. .. .	208
FÜNFSTÜCK, M.— <i>Research on Lichens</i> .. .. .	208
JAJTA, A.— <i>Chinese Lichens</i> .. .. .	208
ZANFLOGNINI, CARLO— <i>Lichen-Flora</i> .. .. .	209
FARLOW, W. G.— <i>Lichens from Galapagos</i> .. .. .	209
ALLESCHER, ANDREAS— <i>Kryptogamen-Flora: Fungi in perfecti</i> .. .. .	209
DELACROIX, G.— <i>Black-rot of Grapes</i> .. .. .	209

	PAGE
FARNETA, R.— <i>Polymorphism of Microfungi</i> .. .. .	209
ENGELKE, C.— <i>Sceptromyces Opizi</i> .. .. .	209
BOS, RITZEMA— <i>Botrytis parasitica</i> .. .. .	209
TAKAHASHI, Y.— <i>Ustilago Panicis miliacei</i> .. .. .	210
MAGNUS, P.— <i>Uredo bistortarum D.C.</i> .. .. .	210
"    " <i>Hyalospora Aspidiotus</i> .. .. .	210
WARD, MARSHALL— <i>Effect of Mineral Starvation on the Parasitism of Puccinia</i> .. .. .	210
BUBÁK, FR.— <i>Cultures of Uredinæ</i> .. .. .	210
BLACKMAN, V. H.— <i>Germination of Teleutospores</i> .. .. .	210
MAIRE, RENÉ— <i>Research on Basidiomycetes</i> .. .. .	211
HARTIG, ROBERT— <i>Dry-rot and other Wood-destroying Fungi</i> .. .. .	211
PETRI, L.— <i>Spore-formation in Gastromycetes</i> .. .. .	211
GUÉGUEN, F.— <i>Adventitious Growths in Fungi</i> .. .. .	212
LANZI MATTEO— <i>Italian Agaricæ</i> .. .. .	212
FARNETI, RODOLFO— <i>Boletus Briosianum sp.n.</i> .. .. .	212
BARBIER, M.— <i>Study of Fungi</i> .. .. .	212
LANZI, MATTEO— <i>Value of Spore Characters</i> .. .. .	212
ROLLAND, L., & OTHERS— <i>Poisoning by Fungi</i> .. .. .	212
SHIBATA— <i>Cytology and Physiology of Endophytic Mycorrhiza</i> .. .. .	213
POTTER, M. C.— <i>Potato Diseases</i> .. .. .	213
BRIOSI, GIOVANNI— <i>Fungus Diseases in Italy</i> .. .. .	213
LAGARDE, J.— <i>Fungi of Mount Ventoux</i> .. .. .	214
MAGNAGHI, ANGELO— <i>Fungi of Lomellina</i> .. .. .	214
"    " <i>Fungus Flora</i> .. .. .	214
HENNINGS, P.— <i>African Fungi</i> .. .. .	214
"    " <i>Fungus Flora of Sao Paulo</i> .. .. .	214
FARLOW, W. G.— <i>Fungi from Galapagos</i> .. .. .	214
PATOUILLARD, N.— <i>Extra-European Fungi</i> .. .. .	215
LANZI, MATTEO— <i>Il Trattato dei Funghi</i> .. .. .	215
JUEL, H. O.— <i>Taphriulum, a New Genus of Protomycetes</i> .. .. .	331
DANGEARD, P. A.— <i>Protascus, a New Genus</i> .. .. .	332
BACCARINI, P.— <i>Endogone</i> .. .. .	332
TRAVERSO, G. B., & OTHERS— <i>Sclerospora</i> .. .. .	332
SERBINOW— <i>New Chytridiaceæ</i> .. .. .	333
MANGIN, L.— <i>Disease of Chestnut Trees</i> .. .. .	333
MATRUCHOT, L., & C. WEHMER— <i>Mucorinæ</i> .. .. .	333
VUILLEMIN, PAUL— <i>Study of Absidia</i> .. .. .	333
HENNINGS, P.— <i>New Discomycetes</i> .. .. .	334
MAYR, H.— <i>Disease of Fir Trees</i> .. .. .	334
HENNINGS, P.— <i>Ruhlandiella berolinensis g. et sp. n.</i> .. .. .	334
MÜLLER-THURGAU, HERM.— <i>Disease of the Vine</i> .. .. .	334
JACZEWSKI, A. VON— <i>Disease of Sorbus Aucuparia</i> .. .. .	335
SALMON, E. S.— <i>Gooseberry Mildew in Europe</i> .. .. .	335
SANDERS, J. G.— <i>Notes on Erysiphaceæ</i> .. .. .	335
STARBÄCK, KARL— <i>Xylariæ of South America</i> .. .. .	335
LEPESCHKIN, W. W.— <i>Study of Heredity</i> .. .. .	335
GUILLIERMOND, A.— <i>Cytology of Yeast</i> .. .. .	335
HANSEN, CHR. EMIL— <i>Formation of Yeast-Spores</i> .. .. .	336
IWANOWSKI— <i>Development of Yeast in Sugar Solution without Fermentation</i> .. .. .	337
NEUVILLE, H.— <i>Industrial Ferments of Eastern Asia</i> .. .. .	337
SYDOW, H. & P.— <i>Asterconium Saccardoii</i> .. .. .	337
POTTER, M. C., & OTHERS— <i>Septoria</i> .. .. .	337
CONSTANTIN & LUCET— <i>Sterigmatocystis pseudonigra</i> .. .. .	338
COUPIN, HENRI— <i>Nutrition of Sterigmatocystis niger</i> .. .. .	338
HALL, C. VAN— <i>St. John Disease of Peas</i> .. .. .	338
VOGLINO, PIETRO— <i>Polydesmus exitiosus and Alternaria Brassicæ</i> .. .. .	338
CZAPEK, F.— <i>Proteid Formation in Moulds</i> .. .. .	528
RAPP, R.— <i>Rennet-like Enzyme from Yeast</i> .. .. .	528
GUÉGUEN, F.— <i>Helminthosporium macrocarpum</i> .. .. .	528
REINITZER, F.— <i>Disease of Apples</i> .. .. .	529
SCHILBER-ZKY, KARL, & OTHERS— <i>Monilia Disease</i> .. .. .	529
BOS, J. RITZEMA— <i>Botrytis parasitica</i> .. .. .	529

	PAGE
PRUNET, A.— <i>Botrytis vulgaris</i> on Figs .. .. .	529
MORGAN & ROLAND THAXTER— <i>New Hyphomycetes</i> .. .. .	529
LONG, WILLIAM, H.— <i>Ravenelias</i> of the United States and Mexico .. .. .	530
HOLWAY, E. W. D., & OTHERS— <i>Notes on Uredineæ</i> .. .. .	530
ARTHUR, J. C., & W. A. KELLERMAN— <i>Cultures of Uredineæ</i> .. .. .	530
DIETEL, P.— <i>Rusts of Leguminosæ</i> .. .. .	531
BUBÁK, FR.— <i>New or Critical Species of Uromyces</i> .. .. .	531
MANGIN, L., & P. VIALA—“ <i>Phthiriose</i> ,” a Disease of the Vine .. .. .	531
ARTHUR, J. C.— <i>Problems in the Study of Plant Rusts</i> .. .. .	531
MÖLLER, ALFRED— <i>Merulius lacrymans</i> .. .. .	532
SMITH, WORTHINGTON, G.— <i>Agaricus (Collybia) Henriettæ</i> sp. n. .. .. .	532
GODFRIN, JULIEN— <i>Critical Agarics</i> .. .. .	532
HOLLÓS, L.— <i>Species of Disciseda</i> .. .. .	532
JOHNSTON, JOHN, R.— <i>Cauloglossum transversarium</i> .. .. .	532
COOKE, M. C., & OTHERS— <i>British Mycology</i> .. .. .	533
DELEZENNE, C., & H. MOUTON— <i>Presence of a Kinase in Basidiomycetes</i> .. .. .	533
MULLER, P. E., & F. CAVERS— <i>Mycorrhiza</i> .. .. .	533
McKENZIE, A., & A. HARDEN— <i>Biological Method for Resolving Inactive Acids into their Optically Active Components</i> .. .. .	533
OLIVER, F. W., & ERNEST S. SALMON— <i>Fossil Fungi</i> .. .. .	534
HOLLRUNG, M.— <i>Jahresbericht der Pflanzenkrankheiten</i> .. .. .	534
WEHMER, C.— <i>Decomposition of Lactic Acid by Fungi</i> .. .. .	534
CZAPEK— <i>Proteid Formation in Moulds</i> .. .. .	534
TEICHERT, KURT— <i>Fungi in Dairy Products</i> .. .. .	534
BRENER, WILHELM— <i>Fat-destroying Fungi of Seeds</i> .. .. .	534
FERRARIS, TEODORO— <i>Fungus Flora of Piedmont</i> .. .. .	535
ALLESCHER, A.— <i>Kryptogamen-Flora</i> .. .. .	535
BRESADOLA, J.— <i>Fungi Polonici</i> .. .. .	535
HARIOT, P., & N. PATOUILLARD— <i>Fungi from New Caledonia</i> .. .. .	535
VESTERGREN, TYCHO— <i>Micromycetes variiores selecti</i> .. .. .	535
CAVAIA, F.— <i>Rare Sicilian Fungi</i> .. .. .	535
BÄUMLER, J. A.— <i>Cryptogamic Flora of Presburg</i> .. .. .	536
MURRIL, W. A.— <i>Polyporaceæ of North America</i> .. .. .	536
BUBÁK, FRANCIS, & OTHERS— <i>American Mycology</i> .. .. .	536
SACCARDO, P. A.— <i>Notæ mycologicæ</i> .. .. .	537
HENNINGS, P.— <i>East African Fungi</i> .. .. .	537
ZOPF, WILHELM— <i>Products of Metabolism in Lichens</i> .. .. .	537
REED, M., & B. M. DAVIS— <i>Two Marine Lichens</i> .. .. .	537
FINK, BRUCE, & MABEL A. HUSBAND— <i>Notes on Cladonias</i> .. .. .	538
LAFAR, FRANZ— <i>Eumycetic Fermentation</i> .. .. .	538
THAXTER, ROLAND— <i>Notes on Monoblepharis</i> .. .. .	640
KOLKWITZ, R.— <i>Leptomitia lacteus</i> .. .. .	640
BUBÁK, FR.— <i>Phycomycetes</i> .. .. .	641
ROTHERT, W.— <i>Spore-Development in Aphanomyces</i> .. .. .	641
DECKENBACH, CONS. VON— <i>Cænomyces consuens</i> g. et sp. n. .. .. .	641
NEW ENGLAND <i>Choanephora</i> .. .. .	641
STEVENS, F. L.— <i>Fertilisation in Sclerospora</i> .. .. .	642
DAVIS, B. M.— <i>Oogenesis in Saprolegnia</i> .. .. .	642
MATRUCHOT, LOUIS, & OTHERS— <i>Cultivation of Truffles</i> .. .. .	643
PETRI, L.— <i>Peziza vesiculosa</i> .. .. .	644
PEGLION, V.— <i>Potato Disease</i> .. .. .	644
“ “ <i>Destruction of Seeds by Fungi</i> .. .. .	644
NYPÉLS, PAUL— <i>Disease of the Alder</i> .. .. .	644
GUILLIERMOND, A.— <i>Epiplasm of Ascomycetes</i> .. .. .	644
DANGEARD, P. A.— <i>Sexuality of the Ascomycetes</i> .. .. .	644
SALMON, E. S., & EM. MARCHAL— <i>Infection Powers of Ascospores in Erysiphaceæ</i> .. .. .	645
LESAGE, P.— <i>Influence of Substratum on Germination of Spores of Penicillium</i> .. .. .	645
DALE, E.— <i>Observations on Gymnozoceæ</i> .. .. .	646
GUILLIERMOND, A.— <i>Cytology of Yeast</i> .. .. .	646
WILL, H.— <i>Observations on the Vitality of Yeast</i> .. .. .	646
HENNEBERG, W., & OTHERS— <i>Yeast Forms, &amp;c.</i> .. .. .	646
JOHN, E.— <i>Research on Klein's Yeast</i> .. .. .	647

	PAGE
BOKORNY, TH.— <i>Action of Yeast on Albumen</i> .. .. .	647
BEAUVIERE, J., & A. GUILLIERMOND— <i>Structure of Botrytis cinerea</i> .. .. .	647
BRIZI, UGO— <i>Botrytis citricola</i> sp. n. .. .. .	648
VOGLINO, PIETRO— <i>Development of Ramularia xquivoca</i> .. .. .	648
MARCHAL, EM.— <i>Rusts of Cereals</i> .. .. .	648
JACKY, ERNST, & W. BANDI— <i>Experiments with Puccinia</i> .. .. .	648
WARD, H. MARSHALL— <i>Puccinia dispersa and its adaptive Parasitism</i> .. .. .	649
LINDROTH, J. IVAR, & OTHERS— <i>Rusts of Special Natural Orders</i> .. .. .	649
MANGIN, L., & P. VIALA— <i>Bornetina Corium</i> .. .. .	650
DIETEL, P.— <i>Uromyces of Lupins</i> .. .. .	650
MAGNUS, P.— <i>Nomenclature of Uredineæ</i> .. .. .	650
SYDOW, H. & P.— <i>Tilletia abscondita</i> Syd. sp. n. .. .. .	650
BUCHOLTZ, F.— <i>Fungi hypogæi</i> .. .. .	651
HENNINGS, P.— <i>Persistence of Fungal Parasites in altered conditions of the Host</i> <i>Plants</i> .. .. .	651
EMERLING, O., & E. ABDERHALDEN— <i>Chemical Action of Growing Fungi</i> .. .. .	651
MOLLIARD, M., & H. COUPIN— <i>Culture of Sterigmatocystis nigra</i> .. .. .	651
ARCANGELI, G.— <i>Notes on Various Fungi</i> .. .. .	651
SYDOW, H. & P.— <i>Notes on Nomenclature</i> .. .. .	651
BRZEZINSKI, JOSEPH— <i>Canker of Fruit Trees</i> .. .. .	652
MOSS, R. J.— <i>Fungicides</i> .. .. .	652
FERRARIS, J., & OTHERS— <i>Fungus Diseases</i> .. .. .	653
MARCHAL, EM., & G. DELACROIX— <i>Phytopathology</i> .. .. .	653
COTTON, A. D.— <i>Wild Plants as Nurseries of Plant Disease</i> .. .. .	653
BRESADOLA, J.— <i>Fungi Polonici</i> .. .. .	654
MURRILL, W. A., & OTHERS— <i>American Fungi</i> .. .. .	654
HENNINGS, P., & D. M'ALPINE— <i>Australian Fungi</i> .. .. .	655
VESTERGRÉN, T., & OTHERS— <i>New Records of Fungi</i> .. .. .	655
PATOUILLARD, N., & OTHERS— <i>Systematic Notes on Fungi</i> .. .. .	656
ROSENBERG, O.— <i>Fertilisation in Plasmopara</i> .. .. .	745
MATRUCHOT, L., & M. MOLLIARD— <i>Action of Fermentation on the Cell</i> .. .. .	745
SWINGLE, DEANE B.— <i>Spore-Formation in Mucorini</i> .. .. .	745
VUILLEMIN, PAUL— <i>Zygosporcs of Mucorini</i> .. .. .	746
IKENO, S.— <i>Systematic Position of Monascus purpureus</i> .. .. .	746
MARTIN, CH. ED.— <i>Boletus subtomentosus</i> .. .. .	746
STÄGER, ROB.— <i>Infection Experiments with Claviceps</i> .. .. .	746
ENGELKE, C.— <i>Observations on the Ergot of Claviceps purpurea</i> .. .. .	747
DIEDICKE, H.— <i>Relationship between Pleospora and Helminthosporium</i> .. .. .	747
NEGER, F. W.— <i>Studies of Erysiphææ</i> .. .. .	747
WILL, H.— <i>Yeast-forms of Fungi</i> .. .. .	747
CUCUMBER LEAF Disease .. .. .	748
SCALIA, G.— <i>New Disease of Asclepias curassavica</i> .. .. .	748
ERIKSSON, JAKOB, & FR. BUBAK— <i>Rhizoctonia violacea</i> .. .. .	748
MIRSKY, BOJANA— <i>Aspergilleæ Parasitic on Human Beings</i> .. .. .	749
BUBAK, FR., & OTHERS— <i>Notes on Uredineæ</i> .. .. .	749
ERIKSSON, J.— <i>Mycoplasma Hypothesis</i> .. .. .	749
MAGNUS, OSCAR— <i>Changes produced in the Peridial Cell-walls of the Uredineæ</i> .. .. .	749
VOSS, W.— <i>Clamp-Connections and Fusion in the Uredineæ</i> .. .. .	750
MAIRE, RENÉ— <i>Taxonomic and Cytological Notes on Botryosporium pulchellum</i> .. .. .	750
BAMBEKE, VAN— <i>Nuclear Behaviour and Spore-Formation in Hydnangeum carneum</i> .. .. .	750
PAMMEL, L. H., & OTHERS— <i>Diseases of Grasses</i> .. .. .	751
MASSALONGO, C.— <i>Mycological Notes</i> .. .. .	751
GUILLIERMOND, M. A.— <i>Metachromatic Corpuscles in the Ascomycetes</i> .. .. .	751
SMITH, A. LORRAIN— <i>British Microfungi</i> .. .. .	751
MULLER, P. E.— <i>Mycorrhiza</i> .. .. .	751
LAURENT, EMILE— <i>Production of Glycogen in Fungi</i> .. .. .	752
HEINZE, BERTHOLD— <i>Production of Acids by Fungi</i> .. .. .	752
VUILLEMIN, PAUL— <i>Bacteriophagous Acrasieæ</i> .. .. .	752
OLIVE, EDGAR W.— <i>Acrasieæ</i> .. .. .	752
MALME, GUST. O. A. N.— <i>Rinodina</i> .. .. .	753
ZAHLBRÜCKNER, A.— <i>Brazilian Lichens</i> .. .. .	753
NILSON, BIRGER— <i>Morphology of Lichens</i> .. .. .	753
ZAHLBRÜCKNER, A.— <i>Lichen Flora</i> .. .. .	753
BIBLIOGRAPHY .. .. .	753

Lichens.		PAGE
JATTA, A., & OTHERS— <i>Lichens</i> .. .. .		657
MARCUSE, M.— <i>Mycorhiza</i> .. .. .		657
Schizophyta.		
Schizophyceæ.		
HYAMS, ISABEL, & ELLEN RICHARDS— <i>Chemical Composition of Oscillaria prolifica</i> ..		76
GOMONT, MAURICE— <i>New Species of Fischerella</i> .. .. .		76
MOLISCH, H.— <i>Floating Properties of certain Phycochromaceæ</i> .. .. .		339
LÖWENSTEIN, A.— <i>Mastigocladus laminosus</i> .. .. .		657
BRAND, F.— <i>Osmotic Properties of Cells of Cyanophyceæ</i> .. .. .		658
HONE, DAISY S.— <i>Petalonema alatum</i> .. .. .		658
NELSON, N. P. B.— <i>Water-Bloom</i> .. .. .		658
NADSON, G.— <i>Perforating Algae</i> .. .. .		658
LEMMERMANN, E.— <i>Anabæna</i> .. .. .		658
POWELL, C.— <i>Calcareous Pebbles</i> .. .. .		658
BRAND, F.— <i>Cyanophyceæ</i> .. .. .		754
Schizomycetes		
GREIG-SMITH, R.— <i>New Gum Bacterium</i> .. .. .		77
GORINI, C.— <i>Acid-Rennet-forming Bacteria in Milk</i> .. .. .		77
LAMBOTTE, V.— <i>Microbe of the "Loque" Disease of Bees</i> .. .. .		77
MALVOZ, E.— <i>Compound Cilia</i> .. .. .		77
HIMMEL, J.— <i>Use of Neutral Red in the Study of Phagocytosis, &amp;c.</i> .. .. .		78
ACHALME, P.— <i>Identification of some Anaerobic Bacteria</i> .. .. .		78
NICOLLE & TRENEL— <i>Agglutination</i> .. .. .		78
SCHAUDINN, F.— <i>Structure of Bacteria</i> .. .. .		79
SCHMIDT-NIELSEN, S.— <i>Psychrophilic Bacteria</i> .. .. .		79
BODIN, E., & F. PAILHERET— <i>Action of Alcoholic Fermentation on the Bacillus typhosus</i> .. .. .		80
KLEMPERER, FELIX, & MAX SCHEIER— <i>Identity of Rhinoscleroma Bacillus with Friedländer's Bacillus</i> .. .. .		80
KRAUSE, F.— <i>Differentiation of Bacillus typhi abdominalis and Bacillus coli communis</i> .. .. .		81
EICHHOLZ, W.— <i>Bacterium Fragi</i> .. .. .		81
UFFENHEIMER, A.— <i>Bacillus aerogenes aerophilus agilis</i> .. .. .		81
COLE, R.— <i>Bacillus aerogenes capsulatus in Circulating Blood</i> .. .. .		82
GREIG-SMITH, R.— <i>Bacillus vascularum and gummosis</i> .. .. .		82
" " <i>New Ascobacterium from the Sugar-Cane</i> .. .. .		82
GORINI, C.— <i>Bacteria of the Milk-ducts of the Cow</i> .. .. .		83
RIGLER, G. v.— <i>Bacteriology of Natural Mineral Waters</i> .. .. .		83
BESANÇON, F., & OTHERS— <i>Bacillus of Soft Sore</i> .. .. .		83
JOHNSON, W. B.— <i>Gonococcus in the General Circulation</i> .. .. .		84
WILEY, H. W.— <i>Agriculture and Bacteria</i> .. .. .		84
JACKSON, D. D.— <i>Genus Crenothrix</i> .. .. .		215
FOULERTON, A. G. R., & OTHERS— <i>Streptothrix</i> .. .. .		215
CHRZASZCZ— <i>Micro-organisms of Barley and Malt</i> .. .. .		216
GRUBER, TH.— <i>Coccus lactis viscosi and the Causes of Sliminess and Threads in Milk</i> ..		216
ELLRODT, GUSTAV— <i>Penetration of Plants by Bacteria</i> .. .. .		216
EMMERLING, O.— <i>Destruction of Non-nitrogenous Organic Substances by Bacteria</i> ..		216
PEIRCE, G. J.— <i>Root-tubercles of Medicago denticulata and other Leguminous Plants</i> ..		217
MACFADYEN, A., & S. ROWLAND— <i>Intracellular Toxin of the Typhoid Bacillus</i> .. .. .		217
DEFALLE, W.— <i>Antibodies of Spores of Bacteria</i> .. .. .		218
IWANHOW, W. W.— <i>Leprosy Bacillus</i> .. .. .		218
TISSIER & MARTELLY— <i>Putrefaction of Meat</i> .. .. .		218
EYBE, J. W. H.— <i>Bacteriology</i> .. .. .		218
FRANKLAND, MRS. PERCY— <i>Bacteria in Daily Life</i> .. .. .		219
MATZSCHITA— <i>Physiology of Spore-formation in Bacteria</i> .. .. .		339
SMITH, R. GRIEG— <i>Bacterial Origin of Vegetable Gums</i> .. .. .		339

	PAGE
BEJERINCK & VAN DELDEN—Colourless Bacterium obtaining Carbon from the Air	340
HASSLAUER—Bacterial Flora of the Nose	340
WEICHELBAUM, A.—Cultivation of Anaerobic Bacteria	340
KONINSKI, KARL—Biology of Anaerobic Bacteria	340
KUPJUEWIT—Effect of Oil on Bacteria	340
RODELLA—Bacteria in Pus from a Gas-containing Abscess	341
FERNANDEZ, D.—Pigment Bacterium of Water	341
TOYAMA—Bacterium Pathogenic for House Rats	341
ESMARCH, ERWIN VON—Passage of Bacterium through Filters	341
PETROW—New Red Pigment-forming Bacillus	342
BUHLERT, H.—Question of Species in the Bacteria of Leguminous Tubercles	342
KOVÁRZIK, KARL—Epidemic of Guinea-Pigs caused by a Variety of Bacterium coli	342
WOLFF, ALFRED—Influenza-like Bacillus from a Rat	342
FRIEDBERGER, E.—Influenza-like Bacillus from a Dog	342
SCHWER—Micro-organism infecting small Animals in the Laboratory	342
STEFANSKY—Leprous Sewer Affection of the Skin and Lymph-glands of Rats	342
KLEIN, E.—New Pathogenic Microbe of the Diphtheria Bacillus Group	343
BRONSTEIN, J., & G. W. GRÜNBLATT—Differentiation of the Diphtheria and Pseudo-Diphtheria Bacillus	343
JOCHMANN, GEORG—Rapid Diagnosis of Typhus Bacilli	343
JAEGER, H.—Characters of Meningococcus intracellularis	343
KINDBOG, A.—Pneumococcus which liquefies Gelatin	348
HARRISON, F. C., & M. CUMMING—New Bacterium in freshly-drawn Milk	343
FEYFER, DE, & OTHERS—Paratyphoid Fever	344
CASTELLANI, ALDO—Etiology of Sleeping Sickness	344
TSIKLINSKY—Thermophilous Bacteria	539
ITERTSON, G. VAN, JUN.—Accumulation Experiments with Denitrifying Bacteria	539
GERLACH & VOGEL—Nitrogen-fixing Bacteria	540
FREMLIN, H. S.—Culture of the Nitroso-Bacterium	540
SCHNEIDER, ALBERT—Motility of Rhizobium	540
ELLIS, DAVID—Observations on Sarcina, Streptococcus, and Spirillum	540
NATHANSON, A.—New Group of Sulphur-Bacteria	540
FUCHS, E.—Staining of Streptotrichaceæ	541
ANDREWES, F. W.—Resisting Powers of Staphylococcus pyogenes aureus	541
MACFADYEN, ALLAN—Immunising Effects of Contents of Typhoid Bacillus	541
VAILLARD, L., & CH. DUPTER—Bacillus of Epidemic Dysentery	659
FREUDENREICH, ED. V.—Nitrogen-assimilating Bacteria	659
DEAN, G.—Disease of the Rat caused by an Acid-fast Bacillus	660
HAUSEMANN, V.—Acid-fast Bacilli in Python reticularis	660
BEHRENS, J.—Retting of Flax and Hemp	661
RODELLA, A.—Presence of strictly Anaerobic Butyric Acid Bacilli (and of other Anaerobic Species in hard Cheese	661
MEYER, H., & F. RANSOM—Researches on Tetanus	661
ISSATCHENKO, M. B.—Experiments with Bacterial Light	662
GRANDI, SILVIO DE—Observations on the Flagella of the Tetanus Bacillus	663
CATTERINA, G.—Flagellated Micrococcus found in a Septicæmia of Rabbits	663
HINZE, G.—Thiophysa volutans	754
ZACHARIAS, OTTO—Achromatium oxaligerum	755
PATTERSON, J. HUME—Salmon Disease	755
MARTIN, SYDNEY—Chemical Products of Diarrhœa-producing Bacteria	755
BARNARD, J. E., & ALLAN MACFADYEN—Luminous Bacteria	756
BARNARD, J. E., & H. DE R. MORGAN—The Bactericidal Action of some Ultra-violet Radiations as Produced by the Continuous-Current Arc	756
KLEIN, E.—Agglutination by Blood of Emulsions of Microbes, with Special Reference to Specificity	756
MARCHOUX, E., & A. SALIMBENI—La Garotilla	756
TISSIER, H., & E. GASCHING—Researches on the Fermentation of Milk	756

## Mycetozoa.

PINCY—Culture of Myzomyctes	84
MORGAN, A. F.—Lepidoderma	344

Dec. 16th, 1903

## MICROSCOPY.

## A. Instruments, Accessories, &amp;c.

## (1) Stands.

	PAGE
NELSON, E. M.— <i>A Two-speed Fine Adjustment</i> (Fig. 2) .. .. .	19
IVES, F. E.— <i>New Bincular Microscope</i> (Fig. 3) .. .. .	85
WATSON & SONS' <i>Metallurgical Microscope</i> (Fig. 4) .. .. .	86
"   " <i>Museum Microscope</i> (Fig. 5) .. .. .	88
"   " <i>Method of Fitting the Stage and Limb of Van Heurck Microscope</i> (Fig. 6) .. .. .	88
"   " <i>Attachable Mechanical Stage</i> (Fig. 7) .. .. .	89
PORTABLE <i>Class-Microscope</i> (Fig. 8) .. .. .	89
BARBOUR'S <i>Pocket Microscope</i> (Fig. 9) .. .. .	90
BIBLIOGRAPHY .. .. .	90
BOURGUET, A.— <i>New Arrangement for avoiding Injury to Preparations when Focus-</i> <i>ing with High Powers</i> (Figs. 37 and 38) .. .. .	220
FORGAN, W.— <i>Modern Fine Adjustments</i> .. .. .	221
BECK'S <i>Portable "Star" Microscope</i> (Fig. 54) .. .. .	345
" <i>Process Microscope</i> (Fig. 55) .. .. .	346
" <i>Pathological Microscope</i> (Fig. 56) .. .. .	346
" <i>Metallurgical Microscopes</i> (Fig. 57) .. .. .	348
BAUSCH & LOMB'S <i>Continental Microscope. BB Model</i> (Fig. 58) .. .. .	349
OLD <i>Microscope by M. Pillischer</i> (Figs. 121 and 122) .. .. .	542
NEW <i>Portable Microscope</i> (Figs. 123 and 124) .. .. .	543
BECK'S <i>Portable Continental Model</i> (Figs. 125 and 126) .. .. .	544
LEITZ' <i>New Double-hinged Limb-holder</i> (Figs. 127 and 128) .. .. .	545
KORISTKA'S <i>Mechanical Stage</i> (Fig. 129) .. .. .	547
" <i>Hand Magnifiers</i> (Fig. 130) .. .. .	548
NELSON, E. M.— <i>An Old Non-Achromatic Simple Microscope</i> (Figs. 143-148) .. .. .	587
"   " <i>An Early Compound Microscope with a Mirror attached to its Limb</i> (Fig. 149) .. .. .	590
"   " <i>An Improved Horseshoe Stage</i> (Figs. 150 and 151) .. .. .	591
LEITZ' <i>New Stand and Fine Adjustment</i> (Figs. 152-154) .. .. .	665
KRAUS, R.— <i>New Regulating Arrangement for a Hot Stage</i> .. .. .	669
WATSON'S <i>New Scöop Mechanical Stage</i> (Fig. 155) .. .. .	669
REGAUD, CL., & NACHET— <i>New Microscopical Stand with a Movable Stage capable</i> <i>of Large Movements</i> .. .. .	670
WATSON'S <i>New Pattern Portable Microscope</i> (Fig. 156 and 157) .. .. .	670
LEITZ' <i>Mineralogical Stand No. I.</i> (Fig. 163) .. .. .	758
" <i>Mineralogical Stand No. II.</i> (Fig. 164) .. .. .	758
" <i>Handloupes</i> (Figs. 165 and 166) .. .. .	761
BOLEY, P.— <i>Very Powerful Micrometric Microscope</i> .. .. .	761
WATSON'S "Argus" <i>Attachable Mechanical Stage</i> (Fig. 167) .. .. .	761
A LENS <i>Pseudoscope</i> .. .. .	762

## (2) Eye-pieces and Objectives.

BARBOUR'S <i>Pocket Magnifier</i> (Fig. 9) .. .. .	91
BOURGUET'S <i>New Index Ocular</i> (Fig. 10) .. .. .	91
BIBLIOGRAPHY .. .. .	91
HUNTER, J.— <i>Eye-piece Lens Interval as arranged for Achromatism</i> (Fig. 39) .. .. .	221
SCHMIDT, H.— <i>Graphic Representation of the Correction Distance of an Objective</i> .. .. .	762
EBERHARD, G.— <i>The Injurious Effect of Cement upon Objectives</i> .. .. .	762
BIBLIOGRAPHY .. .. .	763



(3) Illuminating and other Apparatus.

	PAGE
WATSON & SONS' Macro-Illuminator .. .. .	91
"    "    Incandescent Gas Lamp (Fig. 11) .. .. .	92
G. JOHNSTONE STONEY'S Improved Heliostat (Fig. 12)   .. .. .	92
(HESHIRE, F. J.—Method of Using Abbe's Apertometer (Fig. 13) .. .. .	93
"    "    Simple Method of Focometry and Apertometry (Figs. 14 and 15) .. .. .	94
WATSONS' New Standard Electric Lamp (Fig. 16) .. .. .	95
SCHAEFFER, W.—Small Electric Light for Photomicrography (Figs. 17-19) .. .. .	95
LEE, A. B.—Illumination, and the Use of the Condenser in Histological Micrography .. .. .	97
ILLUMINATING Apparatus for Metallography (Figs. 20-24) .. .. .	98
ORIGIN of the Davis Shutter .. .. .	99
(HESHIRE, F. J.—Simple Form of Reflecting Polariser (Fig. 25) .. .. .	99
BIBLIOGRAPHY .. .. .	100
KORISTKA'S Large Reflecting Mirror (Fig. 59) .. .. .	349
POLL, H.—New Electrical Microscope Lamp (Fig. 60) .. .. .	350
ENGELMANN'S Microspectral Objective with Detachable Thorp's Grating and Detachable Polariser (Figs. 61-65) .. .. .	351
ELLIOTT, L. B.—New Projection Apparatus for Scientific Work (Figs. 131-134) .. .. .	549
KORISTKA'S Apparatus for the Microscopic Projection of Liquid Preparations (Fig. 135) .. .. .	553
"    "    Abbe Camera Lucida with Lens-Holder (Fig. 136) .. .. .	554
DOWDY, S. E.—Colour Illumination of Microscopic Objects .. .. .	671
NELSON, E. M.—Early Glass Micrometers .. .. .	672
BARUS—Method of Demonstrating Newton's Colours by Transmitted Light .. .. .	672
" VILLAGIO," & J. RHEINBERG—Wide Illuminating Cones .. .. .	673
MONOCHROMATIC Light Apparatus (Fig. 158) .. .. .	674
BIBLIOGRAPHY .. .. .	674
TUBEUF'S Drawing Apparatus (Fig. 168) .. .. .	763
FUESS' Hemispherical Gypsum and Metal Reflectors (Fig. 169) .. .. .	763

4) Photomicrography.

SCHAEFFER, W.—Stereoscopic Photography of Microscopic Objects .. .. .	100
"    "    Improvements in the Vertical Microphotographic Camera (Fig. 26) .. .. .	100
BAGSHAW'S 'Elementary Photomicrography' .. .. .	101
BIBLIOGRAPHY .. .. .	101
TURNER, E. R.—On a New Arrangement for taking Photomicrographs in Colours .. .. .	118
IVES, F. E.—New Device for Stereoscopic Photomicrography (Figs. 40 and 41) .. .. .	223
TERRAS, J. A.—New Upright Photomicrographic Apparatus (Fig. 42) .. .. .	224
BIBLIOGRAPHY .. .. .	226
ROWE, A. W.—On the Photomicrography of Opaque Objects as applied to the Delineation of the Minute Structure of Chalk Fossils .. .. .	242
KORISTKA'S Simplified Vertical Camera (Fig. 66) .. .. .	355
MÜLLER, F. W.—Apparatus for Photographing with Light incident from above and below (Figs. 67-70) .. .. .	355
SCHAEFFER'S Stereoscopic Photomicrography with Weak Magnification (Figs. 159-161) .. .. .	671
FOOT, KATHARINE, & ELLA C. STROBELL—New Method of Focussing in Photomicrography .. .. .	677
BECK, C., & H. ANDREWS—Photographic Lenses .. .. .	677
BIBLIOGRAPHY .. .. .	678
WATSON, W. F.—Photography by Natural Lenses .. .. .	764
BIBLIOGRAPHY .. .. .	764

(5) Microscopical Optics and Manipulation.

SPITTA, E. J.—An Arrangement for obtaining Monochromatic Light with the Mixed Jet (Fig. 1) .. .. .	15
RHEINBERG, J.—Common Basis of the Theories of Microscopic Vision, treated without the Aid of Mathematical Formulæ .. .. .	102
STEINHEIL & VOIT'S 'Handbuch der Angewandten Optik' .. .. .	102
BIBLIOGRAPHY .. .. .	102

LEISS' <i>New Crystal Refractometer for the Determination of the Refractive Index of Large and Microscopically Small Objects</i> (Figs. 43 and 44) .. .. .	226
HILGER, ADAM— <i>Michelson Echelon Diffraction Grating</i> .. .. .	228
SIEDENTOFF, H., & R. ZSIGMONDY— <i>Visibility of Ultra-Microscopic Particles</i> .. .. .	228
STRINGER, E. B.— <i>A New Method of Using the Electric Arc in Photomicrography</i> .. .. .	276
SIEDENTOFF, H.— <i>Engelmann's Microspectralphotometer with Grating Spectrum</i> (Figs. 71-73) .. .. .	359
KOENIGSBERGER'S <i>Microphotometer for the Measurement of Light-Absorption</i> (Figs. 74 and 75) .. .. .	362
GORDON, J. W.— <i>The Helmholtz Theory of the Microscope</i> (Plate VI, Figs. 76-116)	381
RAYLEIGH, LORD— <i>On the Theory of Optical Images, with Special Reference to the Microscope</i> (Figs. 117-126) .. .. .	447
"    " <i>On the Theory of Optical Images, with Special Reference to the Microscope</i> (Supplementary Paper) .. .. .	474
SIEDENTOFF, H.— <i>On the Rendering Visible of Ultra-Microscopic Particles and of Ultra-Microscopic Bacteria</i> .. .. .	573
NELSON, E. M.— <i>A Micrometric Correction for Minute Objects</i> (Figs. 139-142) .. .. .	579
"    " <i>On the "Lag" in Microscopic Vision—(continued)</i> .. .. .	583
BIBLIOGRAPHY .. .. .	678
DRUDE'S <i>Theory of Optics</i> .. .. .	765
CONRADY, W. A. E.— <i>Numerical Aperture and Rapidity</i> .. .. .	765
REMEC, B.— <i>Specific Double Refraction of Plant Tissues</i> .. .. .	765
VON KRIES, J.— <i>Visual Purple</i> .. .. .	766
KIME, J. W.— <i>Some Experiments with Actinic Light</i> (Figs. 1-2, plate VIII.) .. .. .	766
BIBLIOGRAPHY .. .. .	766

## (6) Miscellaneous.

GLAZE BROOK— <i>Cantor Lectures, 1902: Glass for Optical Purposes</i> .. .. .	102
MOLISCH'S <i>New Freezing Apparatus</i> (Fig. 27) .. .. .	103
BIBLIOGRAPHY .. .. .	103
NELSON, E. M.— <i>Comparison of British and Metrical Measures at the same Temperature</i> .. .. .	364
JENA <i>Glass</i> .. .. .	554
PERCIVAL, A. S.— <i>The Microscope</i> .. .. .	678
BIBLIOGRAPHY .. .. .	678

## B. Technique.

## (1) Collecting Objects, including Culture Processes.

WILEY, H. W.— <i>Apparatus for Collecting Samples of Earth for Bacteriological Examination</i> .. .. .	104
RIVAS, D.— <i>Anaerobic Cultivation</i> (Figs. 28 and 29) .. .. .	104
CZAPLEWSKI, E.— <i>Cultivating the Influenza Bacillus</i> .. .. .	105
BIBLIOGRAPHY .. .. .	105
KLEIN, E.— <i>Method of Detecting the Presence of Bacillus coli communis in Shellfish</i> .. .. .	229
BIBLIOGRAPHY .. .. .	229
FREMLIN, H. S.— <i>Anaerobic Plate Cultures</i> .. .. .	366
GRUBBS, S. B., & E. FRANCIS— <i>Ring Test for Indol</i> .. .. .	366
BRONSTEIN, J., & E. N. GRÜNBLATT— <i>Differentiation of True and False Diphtheria Bacilli</i> .. .. .	366
ZIELLECKEY, R.— <i>Differentiation of B. coli and B. typhosus</i> .. .. .	367
RIVAS, D.— <i>Anaerobic Cultivations</i> .. .. .	367
FITZGERALD, MABEL P., & G. DREYER— <i>Differentiation of B. typhosus and B. coli</i> .. .. .	367
ALTSCHÜLER, E.— <i>Enrichment Method for Typhoid Bacilli</i> .. .. .	368
BEHRENS, W.— <i>Apparatus for Decanting off Culture Fluids</i> (Fig. 137) .. .. .	557
TONZIG, C.— <i>New Economical Thermostat of Simple and Light Construction</i> .. .. .	678
FREUDENREICH, E. V., & OTHERS— <i>Milk-Agar as a Medium for the Demonstration of the Production of the Proteolytic Enzyme</i> .. .. .	679

	PAGE
MONTGOMERY, F. E.— <i>Method of Preparing Sugar-free Bouillon</i> .. .. .	767
MOORE, G. T.— <i>Cultivation Medium for Algæ</i> .. .. .	767
NEBEL, A.— <i>Demonstration of Tubercle Bacilli in Sputum</i> .. .. .	767
BANDI, J.— <i>New Method of Isolating B. icteroïdes</i> .. .. .	768
BARTARELLI, E.— <i>Tubes for the Preparation of Aërobie and Anaërobie Cultures under the Influence of Coloured Rays</i> .. .. .	768

## (2) Preparing Objects.

NUTTING, E. S.— <i>Fixation of Blood-Films and the Triacid Stain</i> .. .. .	229
GAGE, C. S.— <i>Simple Device for Carrying Minute Objects through the Grades of Cedar Oil and Paraffin</i> .. .. .	230
OSTERGREN, HJALMAR— <i>Ether as a Narcotising Medium for Aquatic Animals</i> ..	308
MAZZARELLI, G.— <i>Demonstrating the Structure of Gastropods</i> .. .. .	308
SCHAEFFER, J.— <i>Decalcification Method</i> .. .. .	558
DOWDY, S. E.— <i>Reagent Bottle</i> .. .. .	558
BROUGHTON, S.— <i>Decantation Method for Cleaning Diatoms</i> .. .. .	679
BOLTON, B. M., & D. L. HARRIS— <i>Rapid Method of Hardening and Imbedding Tissues</i> .. .. .	768
KEELEY, F. J.— <i>Preparation of Diatoms</i> .. .. .	768
SCHOENFELD, H.— <i>Fixation of the Mammalian Egg in the Uterine Cavity</i> .. ..	769
MÜLLER, F.— <i>Improvements of Aubertin's Method for Sticking on Celloidin Sections</i>	769
LITTLE, E. O.— <i>Preparing Sections of Cancellous Bone</i> .. .. .	769
BERG, W.— <i>Contributions to the Theory of Fixation, with particular regard to the Cell-nucleus and its Albuminous bodies</i> .. .. .	770

## (3) Cutting, including Imbedding and Microtomes.

KOLMER, W., & H. WOLFF— <i>Simple Method of Making Thin Paraffin Sections</i> ..	105
SCRIVEN, J. B.— <i>Preparing Serial Sections of Insects</i> .. .. .	106
ABEL, M.— <i>Examining Oligochæta</i> .. .. .	106
JUNG'S <i>New Student's Microtome</i> (Figs. 45 and 46) .. .. .	230
PIERCE, N. B.— <i>Sectioning Fresh Plant-Tissues</i> .. .. .	231
STARLINGER, J.— <i>Improvement in Reichert's Sliding Microtome</i> (Fig. 47) ..	231
LEFEVRE, G.— <i>New Method of Imbedding Small Objects</i> (Figs. 48-51) .. .. .	233
GAGE, S. H.— <i>New Razor-holder and Adjustable Clamp for the Minot Microtome</i> ..	234
BIBLIOGRAPHY .. .. .	234
REITTERER, E.— <i>Fixing and Imbedding dense Connective Tissue</i> .. .. .	369
PRANTER, V.— <i>New Methods of Paraffin Imbedding</i> .. .. .	369
PLEČNIK, J.— <i>Carbon Tetrachloride as a clearing Fluid</i> .. .. .	370
MARPMANN, G.— <i>New Imbedding Medium</i> .. .. .	558
SOLGER, B.— <i>New Freezing Plate for Hand Microtome</i> (Fig. 138) .. .. .	558
BAIN, S. M.— <i>Manipulation of Sections of Leaf-cuticle</i> .. .. .	770
MILLER, C. H.— <i>Imbedding in Celloidin</i> .. .. .	770
STREETER, G. L.— <i>Use of Paraffin Imbedding for Medullary Sheath Staining</i> ..	771
REINSCH, P. F.— <i>New Method for the Preparation of Horizontal Sections of thin Laminated Vegetable Flat Tissues</i> .. .. .	771
BIBLIOGRAPHY .. .. .	771

## (4) Staining and Injecting.

GOLOVINE, E.— <i>Fixing Neutral Red</i> .. .. .	106
CHILESOTTI, E.— <i>Staining Axis-Cylinders with Carmin</i> .. .. .	107
SCHOENEMANN, A.— <i>Staining and Preservation of Series of Sections on Paper Slips</i>	107
HORNIKER, E.— <i>Staining the Plague Bacillus</i> .. .. .	108
REUTER, K.— <i>Staining Malaria Parasites with A-Methylen-Blue-Eosin</i> .. .. .	108
MAURER, G.— <i>Staining the Parasites of Malaria pernicioso</i> .. .. .	108
ELLIS, D.— <i>Demonstration of Flagella in Coccacæ</i> .. .. .	109
STEBBINS, J. H., JUN.— <i>Stain for Elastic Fibres</i> .. .. .	109
CROSBIE, F.— <i>Staining Directions for Photomicrography</i> .. .. .	234
CIACCIO, C.— <i>Method of Demonstrating the Secretory Canaliculi in Supra-renal Capsules</i> .. .. .	235

	PAGE
SCHAUFFLER, W. G.— <i>Staining Diphtheria Bacilli and Cholera Vibrios</i> .. .. .	235
GEMELLI, E.— <i>New Method of Staining Flagella</i> .. .. .	235
WOOLLEY, P. G.— <i>Staining the Reticular supporting Network of Malignant Neoplasms by Mallory's Method</i> .. .. .	236
MILROY, J. A.— <i>Staining Reactions of Proteid Crystals</i> .. .. .	236
ROSS, RONALD— <i>Improved Method for the Microscopical Diagnosis of Intermittent Fever</i> .. .. .	236
LITTLE, E. O.— <i>Method for Demonstrating Nematocyst Cells in Hydra</i> .. .. .	237
FICKER, M.— <i>New Method of Staining Bacterial Granules</i> .. .. .	237
VALENTI, G. L.— <i>Easy Method of Staining the Flagella of Bacteria</i> .. .. .	237
HAMLYN-HARRIS, R.— <i>Apparatus for Facilitating the Manipulation of Celloidin Sections (Fig. 52)</i> .. .. .	238
BIBLIOGRAPHY .. .. .	239
PECK, J. W.— <i>Differential Stain of B. Diphtheriæ</i> .. .. .	370
ROSSI, G. DE— <i>Flagella Staining</i> .. .. .	370
ELMASSIAN, M., & E. MIGONE— <i>Demonstrating Trypanosomata</i> .. .. .	371
SCHAFFER, J.— <i>New Glass Staining Trough</i> .. .. .	371
FICKER, M.— <i>Method for Staining Bacterial Granules</i> .. .. .	371
SCHOENEMANN, A.— <i>Staining and Preservation of Serial Sections on Paper Strips</i> .. .. .	371
WIJHE, J. W. VAN— <i>Method for Demonstrating Cartilaginous Micro-skeletons</i> .. .. .	372
SMITH, W. H.— <i>Method for Staining Sputum for Bacteriological Examination</i> .. .. .	372
SCHÖUTER, H., & H. ARONSON— <i>Staining Nervous Tissue with Gallein</i> .. .. .	559
MOREL & DOLÉRIS— <i>Modification of the Method for Staining with the Ehrlich Triacid Solution</i> .. .. .	560
BIBLIOGRAPHY .. .. .	560
JUNG'S Apparatus for the quick and uniform Staining of Serial Sections and for the Treatment of them in Number with Reagents .. .. .	679
HARRIS, H. F.— <i>Modification of the Romanowsky Stain</i> .. .. .	680
SMITH, W. H.— <i>Method of Staining Sputum for Bacteriological Examination</i> .. .. .	772
TOMPA, V. A.— <i>Two Botanical Staining Methods</i> .. .. .	772
ROMANOFF, B.— <i>Vital Staining of Micro-Organisms</i> .. .. .	773
PUCHBERGER, G.— <i>Vital Staining of Blood Plates in Man with "Brilliantkresylblau"</i> .. .. .	773
GROOT, J. G. DE— <i>Iron Carmalum</i> .. .. .	773
CHILESOTTI, E.— <i>Modification of the Uranium Carmine Staining of Schmaus</i> .. .. .	773
HINTEBERGER, A.— <i>Thermophore for use in Staining</i> .. .. .	774
(5) Mounting, including Slides, Preservative Fluids, &c.	
DOWDY, S. E.— <i>Making Preparations of Crystals for the Micropolariscope</i> .. .. .	110
" " <i>Slide for Pond Life (Fig. 53)</i> .. .. .	239
BIBLIOGRAPHY .. .. .	373
KOZLOWSKI, B.— <i>Staining and Mounting Urinary Sediment</i> .. .. .	560
MAHPMANN, G.— <i>New Medium for Mounting Microscopical Preparations</i> .. .. .	560
HILL, J. A.— <i>Method of Mounting Bacteria from Fluid Media</i> .. .. .	561
FISCHER, C. E. M.— <i>Soluble Glass as Mounting Medium for Examination of Paper</i> .. .. .	774
(6) Miscellaneous.	
INTERESTING Extract from Hooke .. .. .	110
HANDBOOK of Instructions for Collectors .. .. .	110
MANN, G.— <i>Physiological Histology</i> .. .. .	110
CROSS, M. I., & M. J. COLE— <i>'Modern Microscopy'</i> .. .. .	111
WHITNEY, W. R., & A. G. WOODMAN— <i>Microscopic Examination of Paper Fibres</i> .. .. .	111
KELLERMAN, K.— <i>Method of Making Collodion Tubes</i> .. .. .	112
UNNA, P. G.— <i>Ink for Writing on Glass</i> .. .. .	112
HOOKE, J.— <i>New Micrometer (Fig. 30)</i> .. .. .	112
ROSS, L. S.— <i>New Colony-Counter (Figs. 31-33)</i> .. .. .	113
BIBLIOGRAPHY .. .. .	114
MELL, P. H.— <i>Biological Laboratory Methods</i> .. .. .	240
MACMUNN, C. A.— <i>Counting the Red Corpuscles of the Blood</i> .. .. .	240
GLAGE, F.— <i>Fusible Metal Stopper for Test-tubes</i> .. .. .	240
BIBLIOGRAPHY .. .. .	240
ENCYCLOPÆDIA of Microscopical Technique .. .. .	373

	PAGE
EYRE'S <i>Bacteriological Technique</i> .. .. .	374
BIBLIOGRAPHY .. .. .	374
GREENISH, H. G.— <i>Microscopical Examination of Foods and Drugs</i> .. .. .	561
KOB & CO.'S <i>New Sterilisable Hypodermic Syringe for Aseptic and Bacteriological Injection Experiments</i> (Fig. 162) .. .. .	680
STRONG, W. M., & C. G. SELIGMANN— <i>New Method of Counting the Corpuscles of the Blood</i> .. .. .	680
BIBLIOGRAPHY .. .. .	681
HÜBNER, J.— <i>Microscopical Examination of Paper</i> .. .. .	774
CASTELLANI, A.— <i>Detection of Trypanosomes</i> .. .. .	775
SOLLAS, W. J.— <i>Method for the Investigation of Fossils by Serial Sections</i> .. .. .	775
KELLY, B. E.— <i>Application of the Cinematograph Principle to the Study of Serial Sections</i> .. .. .	776
FROST, W. D.— <i>Simple Method of Making Collodion Sacs for Bacteriological Work</i> .. .. .	776
SCHUBERG, A.— <i>Bottle for Immersion Oil</i> .. .. .	777
FRIEDLÄNDER, F. V.— <i>A Modification of the Pantograph for the Drawing of Microscopical Preparations</i> .. .. .	777

### Metallography, &c.

HIORNS, A. H.— <i>Metallography: an Introduction to the Study of the Structure of Metals chiefly by the Aid of the Microscope</i> .. .. .	114
EWING, J. A., & J. C. W. HUMPHREY— <i>Fracture of Metals under repeated Alternations of Stress</i> .. .. .	115
HOLBORN, L., & F. HENNING— <i>Volatilisation and Re-crystallisation of the Platinum Metals</i> .. .. .	115
BIBLIOGRAPHY .. .. .	115
ANDREWS, T.— <i>Microscopic Appearances of Volcanic Dust</i> .. .. .	374
BRIARLEY, H., & F. IBBOTSON— <i>Analysis of Steel-Works Materials</i> .. .. .	375
ROBERTS-AUSTEN, W. C., & T. K. ROSE— <i>Certain Properties of the Alloys of the Gold-Silver Series</i> .. .. .	375
SEKATS, E. A.— <i>Chemical Composition of Limestones. Microscopical Methods</i> .. .. .	681
CHAPMAN, F., & H. J. GRAYSON— <i>Red Rain</i> .. .. .	682
SPELLER, F. N.— <i>New Etching Reagent for Polished Steel Sections</i> .. .. .	682
MAHON, J. J.— <i>The Microscope in Crucible Steel Manufacture</i> .. .. .	682
LANGE, E. F.— <i>Simultaneous Presence of Ferrite and Cementite in Steel</i> .. .. .	683
HALL, J. L.— <i>Effect of Superheated Steam upon the Tensile Strength of Alloys</i> .. .. .	683
JOLY, J.— <i>Improved Method of Identifying Crystals in Rock Sections by use of Birefringence, and Improved Polarising Vertical Illuminator</i> .. .. .	683
BIBLIOGRAPHY .. .. .	684
LONGMUIR, P.— <i>Micrographic Study of Cast Iron</i> .. .. .	777
WEIDMAN, S.— <i>Note on the Amphibole Hudsonite previously called a Pyroxene</i> .. .. .	777
BIBLIOGRAPHY .. .. .	778

*PROCEEDINGS OF THE SOCIETY.*

	PAGE
Meeting, December 17, 1902 .. .. .	116
Anniversary Meeting, January 21, 1903 .. .. .	121
Meeting, February 18, 1903 .. .. .	241
,,    March 18,        ,, .. .. .	244
,,    April 15,       ,, .. .. .	376
,,    May 20,         ,, .. .. .	378
,,    June 17,        ,, .. .. .	562
,,    October 21,     ,, .. .. .	779
,,    November 18,   ,, .. .. .	782

---

GENERAL INDEX TO VOLUME .. .. .	787
---------------------------------	-----





1.



1a.

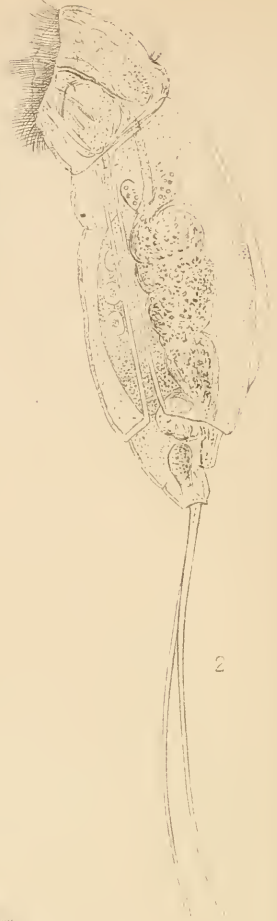

2.

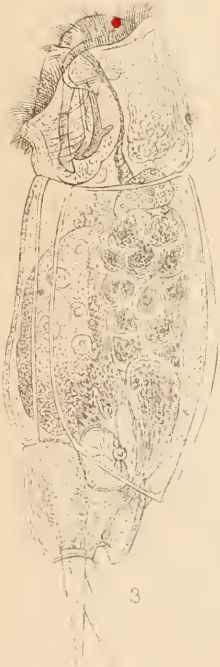

3.



3a.



4.



4a.



183

JOURNAL  
OF THE  
ROYAL MICROSCOPICAL SOCIETY.

FEBRUARY 1903.

TRANSACTIONS OF THE SOCIETY.

I.—*The Rotatorian Genus Diaschiza* :  
*A Monographic Study, with Description of a New Species.*

By F. R. DIXON-NUTTALL, F.R.M.S., and  
The Rev. R. FREEMAN, M.A.

(Read December 17th, 1902.)

PLATES I. TO IV.

It is with a certain amount of diffidence that we venture to put before the Fellows of this Society a monograph with the above title.

The genus *Furcularia* has, since its foundation by Lamarck (1816), been made to contain such a heterogeneous mass of generically distinct rotifers as *Notommata aurita*, *Diglena catellina*, *Scaridium longicaudum*, *Dinocharis pocillum*, &c.

From time to time various authors have divided and subdivided this genus; whilst other authors have referred some of the species to other genera already in existence.

EXPLANATION OF PLATE I.

All figs, except fig. 2,  $\times$  476.

- Fig. 1.—*Diaschiza gibba* Ehren. Lateral view.  
" 1a " " " The male, lateral view.  
" 2 " " *tenuiseta* Burn. Lateral view.  
" 3 " " *sterea* Gosse. Lateral view.  
" 3a " " " Dorsal view.  
" 4 " " *gracilis* Ehren. Lateral view.  
" 4a " " " The male, lateral view.

Feb. 18th, 1903

B

It is evident that Ehrenberg himself acted on the principle that matters had been so much confused, especially in this group of Rotatoria, that he was obliged to pass over without consideration much of the work of his predecessors.

This confusion, however, does not affect us much in the matter of the *Diaschiza*, for most of the species are of later date. We only want to point out that chaos has reigned in Furculariadam.

At last Gosse, discovering more accurate detail of lorica, invented a new genus *Diaschiza*, in which he placed *vulga*, *exigua*, *semiaperta*, *Hoodii*, *pæta*, and *tenuior*. Of these, all were new to science except *semiaperta* and *pæta*. The first is most evidently *Furcularia gibba* of Ehrenberg; the second, Gosse's own *F. caeca*. At one time, seeing the dorsal cleft, Gosse re-names them *Diaschiza semiaperta* and *pæta*; at another time, failing to observe the cleft, he calls them *Furcularia gibba* and *caeca*. Of these species, *gibba*, being the first Ehrenberg described, will serve well as the type species of the genus *Diaschiza*; and in future will stand as *Diaschiza gibba*.

Hence it is not without precedent that we are dissatisfied with the name *Furcularia*; and, thinking the name *Diaschiza* more descriptive of this section of the old genus *Furcularia*, we have no hesitation in taking those *Furculariæ* which satisfy the demands of this genus, and establishing the genus on a sound basis as what may be in future described as *Diaschiza* (Gosse). This will give students a homogeneous genus, and enable them to identify such of the *Notommatadæ* as fall within its limits.

*Generis Charact.*—*Diaschiza* are *Notommatadæ* with the integument of the trunk slightly stiffened into four plates, two subdorsal and two subventral, and with the dorsal and two lateral clefts between these plates strongly marked; also with a bunch of stiff setæ projecting from the foot just above the base of the toes.

There are three divisions of the genus:—I. With frontal eye. II. With cervical eye. III. Without eye.

The following is a list of the fourteen species of this genus which we have been able to observe. One of these, No. 8 (fig. 13), and the males of Nos. 1, 4, and 7 (figs. 1, 4, and 5), are here described for the first time. No. 14 has, however, a very uncertain claim for its position here.

#### I. WITH FRONTAL EYE.

1. <i>Diaschiza gibba</i> Ehrbg.	Greatest size	$\frac{1}{90}$ in. (282 $\mu$ ) A.
2. " <i>globata</i> Gosse	"	$\frac{1}{200}$ in. (127 $\mu$ ) K.
3. " <i>sterca</i> Gosse	"	$\frac{1}{140}$ in. (181 $\mu$ ) F.
4. " <i>gracilis</i> Ehrenberg	"	$\frac{1}{170}$ in. (149 $\mu$ ) H.

## II. WITH CERVICAL EYE.

- |    |   |               |                                  |      |
|----|---|---------------|----------------------------------|------|
| 5. | <i>Diaschiza lacinulata</i> Müller.           | Greatest size | $\frac{1}{160}$ in. (158 $\mu$ ) | G.   |
| 6. | „ <i>ventripes</i> Dixon-Nuttall              | „             | $\frac{1}{190}$ in. (133 $\mu$ ) | J.   |
| 7. | „ <i>Hoodii</i> Gosse                         | „             | $\frac{1}{130}$ in. (195 $\mu$ ) | E 1. |
| 8. | „ <i>Derbyi</i> sp.n. Nuttall and<br>Freeman. | „             | $\frac{1}{180}$ in. (141 $\mu$ ) | I.   |
| 9. | „ <i>exigua</i> Gosse.                        | „             | $\frac{1}{260}$ in. (98 $\mu$ )  | L.   |

## III. NO EYE.

- |     |                                    |               |                                  |      |
|-----|------------------------------------|---------------|----------------------------------|------|
| 10. | <i>Diaschiza caeca</i> Gosse.      | Greatest size | $\frac{1}{125}$ in. (204 $\mu$ ) | C.   |
| 11. | „ <i>tenuior</i> Gosse.            | „             | $\frac{1}{130}$ in. (195 $\mu$ ) | E 2. |
| 12. | „ <i>eva</i> Gosse.                | „             | $\frac{1}{95}$ in. (267 $\mu$ )  | B 1. |
| 13. | „ <i>tenuiseta</i> Burn            | „             | $\frac{1}{95}$ in. (267 $\mu$ )  | B 2. |
| 14. | „ ? <i>megaloccephala</i> Glascott | „             | $\frac{1}{127}$ in. (200 $\mu$ ) | I.   |

This genus comes as a connecting link between the Loricata and the Illoricata.

The integument of the greater part of the trunk is stiffened in four plates (in future called the lorica), two latero-dorsal and two ventral. In between these plates, and also to the rear of these plates, the integument is very soft and flexible.

From a front view the cleft between the dorsal plates is seen as a V; that between the lateral plates as a U; and that between the ventral plates is flat as an  $\sqcap$ .

The head is covered with somewhat stiffened integument, not so stiff as the plates on the trunk but stiffer than that on the rear of the trunk. It is separated clearly from the trunk by a neck which is formed by the frontal edges of the four plates.

In shape the body is more or less cylindrical, sometimes laterally, sometimes dorso-ventrally compressed, sometimes neither.

The antennæ are, as usual, three in number, one dorsal, on the head, about three-quarters back from the front. The two lateral are symmetrically placed in the lumbar regions about three-quarters of the way down the trunk in the latero-dorsal plates.

The trunk projects from the lorica into a flexible, somewhat retractile foot, poorly jointed, from which extend two furcate toes.

There are three divisions of the genus, the first possessing a frontal eye; the second a cervical eye on the occiput or hinder part of the brain; the third without a coloured eye-spot.

In every species of the genus the lips of the buccal orifice project more or less. In some, as in *D. Hoodii* q. v., this projection is so marked that it was mistaken by some authors for a projection of the trophi. In no case do the jaws, or any part of them, project through this orifice.

The ciliary wreath is a continuous ring round the outside of the corona, inside which there is a variable arrangement of stiff setæ.

The bunch of setæ on the foot, which is one of the marks of this genus, consists of four or five stiff hairs pointing back in a divergent pencil, just over the base of the toes.

The gastric glands vary but little in shape and size, being usually rather large irregular sacs. In *D. cæca* they are generally pigmented red; in *tenuior* sometimes pigmented brown; in *lacinulata* sometimes pigmented pink. We have never observed anything approaching this in the other species.

The lateral canals are normal, each canal carrying five vibratile tags.

The construction of the jaws of this genus is exceedingly difficult to elucidate either by drawings or description. They consist of the usual parts, but these are attached to plates. By a special arrangement of the muscles which work the unci and rami, it is able suddenly to expand the cavity enclosed within these plates, thus sucking in its food. This suction is its method of securing its food; not, as Gosse suggests, a protruding and prehensile action of the jaws. His drawings in *Manduc. org.* in *Class Rotif. Phil. Trans. Roy. Soc.* pp. 432, 433, pl. 17, figs. 32-37 (*lacinulata* and *gibba*), are much more accurate than his description.

Take, for example, either *D. eva* or *D. ventripes*. The food of these two species is chiefly diatoms. These they secure simply by the suction caused by the rapid expansion of the mastax cavity and the rush of outside matter to fill the vacuum. We have many a time observed a whole hard diatom almost one-third as large as the trunk of the animal sucked in, and without any mastication, pass straight on through the cesophagus right to the stomach, there to be acted upon by the gastric fluids alone.

All the other species feed on spores or flocculent matter, which are sucked in in a similar manner without any attempt at mastication. In fact the jaws of this genus are not used for mastication.

In giving the sizes of the different species, the maximum size observed by us is taken, and in those cases where the immature specimens fall much short of this standard special note is made of that fact. The words "total length" are used to describe the measure taken from the most projecting point of the head to the tip of the toes when carried straight behind. The "breadth" is the width at the widest part of the animal from a dorsal view. The "height" or "depth" signifies the maximum transverse section or elevation from a lateral view. All these measurements vary in every species; but the proportions between them are fairly constant.

All the figures of the plates (except 2 and 8*b*) have been

drawn at the uniform amplification of 476 diameters, so that the relative sizes of the various species allow direct comparison.

## A DICHOTOMOUS SCHEME OF THE GENUS DIASCHIZA.

- A. Eye present.
- B. Eye frontal.
- C. Body long and large, laterally compressed .. *D. gibba*,  $\frac{1}{30}$  in. (282  $\mu$ )  
No. 1.
- CC. Body short, not laterally compressed.
- D. Body almost spherical, small, toes decurved *D. globata*,  $\frac{1}{200}$  in. (127  $\mu$ )  
No. 2.
- DD. Body gibbose, but of medium length.
- E. Toes sharp, straight, lorica moderately stiff, with a projecting tail .. *D. sterea*,  $\frac{1}{140}$  in. (181  $\mu$ )  
No. 3.
- EE. Toes blunt, slightly recurved, lorica remarkably flexible, no projecting tail. *D. gracilis*,  $\frac{1}{170}$  in. (149  $\mu$ )  
No. 4.
- BB. Eye cervical.
- F. Head large, body short, rapidly tapering .. *D. lacinulata*,  $\frac{1}{100}$  in. (158  $\mu$ )  
No. 5.
- FF. Head not conspicuously large, body longer, gradually tapering.
- G. Foot ventral, lorica projecting over the foot. *D. ventripes*,  $\frac{1}{90}$  in. (133  $\mu$ )  
No. 6.
- GG. Foot not ventral, lorica not projecting.
- H. Large species, buccal orifice very projecting, toes much decurved .. *D. Hoodii*,  $\frac{1}{30}$  in. (195  $\mu$ )  
No. 7.
- HH. Small species.
- K. Buccal orifice fairly projecting, toes nearly straight, slightly recurved, body normal. *D. Derbyi*,  $\frac{1}{80}$  in. (141  $\mu$ )  
No. 8.
- KK. Buccal orifice not prominent, toes distinctly decurved, body wedge-shaped. *D. exigua*,  $\frac{1}{260}$  in. (98  $\mu$ )  
No. 9.
- AA. Eye absent.
- L. Toes of normal length and form, considerably less than half the rest of body.
- M. Lorica fairly stiff, body laterally compressed, of even breadth throughout, toes upcurved, gastric glands usually tinted red. *D. exca*,  $\frac{1}{25}$  (204  $\mu$ )  
No. 10.
- MM. Lorica very flexible, body not laterally compressed, tapering slightly fore and aft, toes outcurved, gastric glands sometimes tinted brown. *D. tenuior*,  $\frac{1}{30}$  in. (195  $\mu$ )  
No. 11.
- LL. Toes of abnormal length or form.
- N. Toes flexible, less than two-thirds rest of body, curved.
- O. Toes about half length of rest of body, tapering rapidly about their middle to a flexible thread. *D. eva*,  $\frac{1}{5}$  in. (267  $\mu$ )  
No. 12.
- OO. Toes very short, less than one-fourth rest of body, flexible throughout, head abnormally large, clefts doubtful, no setae on foot. *D. ? megalcephala*,  $\frac{1}{17}$  in. (200  $\mu$ )  
No. 14.
- NN. Toes not flexible, more than two-thirds rest of body, recurved. *D. tenuiseta*,  $\frac{1}{5}$  in. (267  $\mu$ )  
No. 13.

**Diaschiza gibba** Ehrenberg.

Pl. I. figs. 1 and 1a.

## SYNONYMY.

*Furcularia gibba* Ehrenberg.*Diaschiza semiaperta* Gosse.*Furcularia gibba* Gosse.

## BIBLIOGRAPHY.

- EHRENBURG, G. F.—Die Infusionsthierchen. Leipzig, 1838, p. 420, pl. 48, fig. 3.
- GOSSE, P. H.—Manduc. Org. in class Rotif. Phil. Trans. Roy. Soc. London, 1855, p. 433, pl. 17, figs. 35-37.
- HUDSON & GOSSE.—The Rotifera. London, 1889, vol. ii. p. 80, pl. 22, fig. 10; and vol. ii. p. 43, pl. 19, fig. 13.

*Spec. Char.*—Body long, large; back highly gibbous, laterally compressed, abruptly falling off steep to the foot, flat ventrally; face slightly prone; lorica normal diaschiza type, somewhat flexible; dorsal cleft narrow, straight; lateral cleft normal; eye small, frontal; foot short, stout; toes about two-fifths the length of the rest of the body, furcate, thin, style-shaped, slightly acute, and slightly upcurved.

Ehrenberg described this species as *Furcularia gibba*. Gosse, observing the dorsal cleft, re-described it as *Diaschiza semiaperta*. Then, in his account of *Furcularia gibba*, vol. ii. p. 43, he failed to observe this cleft, which in some specimens is difficult to define. Pl. xix. fig. 13, compared with pl. xxii. fig. 10, will show that his two species are identical even to the jaws.

This is the largest species of *Diaschiza*, varying from  $\frac{1}{90}$  in. downwards.

The very peculiar eye, which is small and *absolutely* frontal (not semioccipital as in Gosse's drawing), consists of a hollow hemisphere the flat front of which is clear and transparent, the rest pigmented red.

The foot-glands are very prominent.

The setæ on the foot are especially well marked.

The toes vary in length, shape, and curvature. In some cases they are almost straight, but never observed by us as straight as drawn by Ehrenberg, pl. xlvi. fig. 3; and by Gosse, pl. xix. fig. 13. In other cases they are distinctly recurved, as in Gosse, pl. xxii. fig. 10. All gradations between these two extremes have been noted at various times. As a rule they are thin, tapering gradually to a point, but sometimes they are to be found stouter at the base, yet we have never seen them quite so stout as in Gosse, pl. xix. fig. 13.

This rotifer has a habit of raising its toes over its back.

It sometimes makes a run of flocculent matter as mentioned in Gosse's description of *Furcularia forficula*.

It is rather an active species, feeding rapaciously on floccose matter, which often gives a brilliant red or green colouring to the stomach.

The jaws have the incus short and stout, slightly swelling at the fulcrum, and the manubria crutch-shaped at the end.

*Size*.—Total length from  $\frac{1}{90}$  in. ( $282 \mu$ ) downwards. Toes alone  $\frac{1}{340}$  in. ( $75 \mu$ ); greatest width  $\frac{1}{330}$  in. ( $72 \mu$ ); greatest depth (from dorsum to venter)  $\frac{1}{300}$  in. ( $85 \mu$ ).\*

Common and generally distributed.

*The Male*.—Pl. I. fig. 1a. This sex made its appearance on the 2nd May, 1901, in about a dozen examples in water from Dundee, sent by Mr. J. Hood; and again on April 29th, 1902, in the Big Lake, Knowsley, Lancashire. It has the four plates, the setæ on the foot, the three antennæ, the lateral compression, and the frontal eye, just like the female. It is remarkably large for a male.

The toes are, strange to say, decurved, sharp, and short. This is the main point of external difference from the female. It is without manducatory organs, and is very restless. The sperm-sac is large, and fills the greater part of the body-cavity.

This sex is, as usual, very soft and flexible, contracting and elongating itself, and, in fact, contorting itself into all sorts of shapes and sizes.

The figure is drawn from a stout and well-developed specimen, and the measurements made from a more elongated one. It assumes its most elongated attitude when swimming.

*Size*.—Total length  $\frac{1}{109}$  in. ( $233 \mu$ ); toes alone  $\frac{1}{700}$  in. ( $36 \mu$ ); breadth about  $\frac{1}{700}$  in. ( $36 \mu$ ); height  $\frac{1}{600}$  in. ( $42 \mu$ ).

This sex is very rare.

### *Diaschiza globata* Gosse.

Pl. III. figs. 9 and 9a.

#### SYNONYMY.

*Furcularia sphaerica* Gosse.

#### BIBLIOGRAPHY.

- GOSSE, P. H.—Twelve new Species of Rotifera. Journ. Roy. Micr. Soc., 1887, p. 361.  
 — Twenty-four more new Species of Rotifera. Journ. Roy. Micr. Soc., 1887, p. 861.  
 HUDSON & GOSSE.—The Rotifera. London, 1889, Suppl. p. 37, pl. 31, fig. 30.  
 — The Rotifera. London, 1889, Suppl. p. 26, pl. 31, fig. 16.

*Spec. Char.*—Body short and stout, subpiriform; head slightly narrower than the body; face not prone; neck only slightly

\* Cf. note on our system of recording maximum size, p. 4.

marked; corona encircled by a prominent ring or collar; lorica normal diaschiza type; dorsal cleft broad, well marked; lateral cleft very distinct; eye frontal, large; foot stout; toes short, about one-sixth length of rest of body, furcate, style-shaped, slightly decurved.

Gosse's description gives a very good idea of this species.

The eye, as he states (Suppl. p. 37), is on rare occasions difficult to define, and is always of the nature of scattered pink pigment rather than of a spherical mass.

The "collar" round the corona was in all our examples easily observable.

The jaws are of the same type as those of *D. gibba*; the incus, however, is slightly thinner.

This species is uncommon, and only found in small numbers and in few localities. It is lethargic in its habits whether swimming or crawling.

It feeds on flocculent matter.

For further description we refer our readers to Gosse, only adding that his *t. sphaerica*, from the figure and also from the somewhat vague description, evidently belongs to this species.

*Size*.—Total length  $\frac{1}{200}$  in. (127  $\mu$ ); toes alone  $\frac{1}{1230}$  in. (20  $\mu$ ); greatest breadth  $\frac{1}{507}$  in. (50  $\mu$ ); height  $\frac{1}{480}$  in. (53  $\mu$ ).

Local and uncommon.

### Diaschiza sterea Gosse.

Pl. I. figs. 3 and 3a.

#### SYNONYMY.

*Furcularia sterea* Gosse.

#### BIBLIOGRAPHY.

GOSSE, P. H.—Twenty-four more new Species of Rotifera. Journ. Roy. Micr. Soc., 1887, p. 861.  
HUDSON & GOSSE.—The Rotifera. London, 1889, Suppl. p. 25, pl. 31, fig. 15.

*Spec. Char.*—Body ovate, cylindric, with a soft projection over foot; head thick, truncate; neck a marked constriction; face sub-

#### EXPLANATION OF PLATE II.

All figs.  $\times 476$ .

- Fig. 5—*Diaschiza Hoodii* Gosse. Dorsal view.  
 " 5a " " " Lateral view.  
 " 5b " " " The male, lateral view.  
 " 6 " *lacinulata* Müller. Lateral view.  
 " 6a " " " Ventral view.  
 " 7 " *ventripes* Dixon-Nuttall. Lateral view.



prone; corona extending well down ventral surface of head; lorica not unusually flexible; dorsal cleft wide, fairly distinct; lateral cleft wide, especially towards posterior extremity; eye frontal, double; foot stout, about one-quarter length of lorica; toes about one-third length of rest of body, straight, furcate, style-shaped.

Gosse describes this species from a single specimen, and his drawing is so weak, that were it not for his mention of the massive foot with its over-arching tail, it would be difficult to identify.

From a lateral view the body is slightly arched dorsally, almost straight ventrally.

The lorica ends somewhat abruptly over a stout foot.

The distinctive feature of this species, the above-mentioned tail, is a fleshy projection which varies somewhat in the extent to which it projects. Viewed dorsally, it comes to an almost acute point.

The setæ on the foot are exceedingly short and fine, and hence very difficult to observe, and it was not until one of Zeiss's apochromatic oil-immersion lenses was brought to bear upon them that they were discovered.

The projection over the foot, by its contact with the point from which they invariably originate, has probably reduced them to these small dimensions.

The dorsal and lateral clefts are so distinctly marked, that we have no hesitation in transferring this species to the genus *Diaschiza*.

The dorso-frontal point of the collar projects slightly.

The eye, which is distinctly frontal, consists of two quite separate reniform red spots inside a clear hollow sphere.

The jaws are of the *gibba* type with a very marked crutch to the manubria.

In the toe, the under edge is quite straight, the upper curves down from the wide base to meet the lower in an acute point, hence Gosse's description gives it as slightly decurved.

This species is often very beautiful owing to the green or yellow spores with which it fills its stomach. We have seen specimens which exhibit quite a cluster of vivid emeralds.

*Size*.—Total length  $\frac{1}{140}$  in. to  $\frac{1}{200}$  in. (181–127  $\mu$ ); toes alone  $\frac{1}{610}$  in. to  $\frac{1}{750}$  in. (41–34  $\mu$ ); breadth and height  $\frac{1}{410}$  in. to  $\frac{1}{600}$  in. (62–42  $\mu$ ).

The larger examples were from Dundee; the smaller were adult specimens from this neighbourhood (Lancashire).

Not common, but occurring frequently in certain localities.

**Diaschiza gracilis** Ehrenberg.

Pl. I. figs. 4 and 4a.

## SYNONYMY.

*Furcularia gracilis* Ehrenberg.*Furcularia gracilis* Gosse.

## BIBLIOGRAPHY.

EHRENBERG, C. G.—Die Infusionsthierchen. Leipzig, 1838, p. 421, pl. 48, fig. 6.  
 HUDSON & GOSSE.—The Rotifera. London, 1889, vol. ii. p. 42, pl. 19, fig. 14.

*Spec. Char.*—Body slender, laterally compressed; head round in front; neck a very slight constriction; face sub-prone; corona extending very little down ventral surface of head; lorica flexible; dorsal cleft distinct; lateral cleft distinct, widening posteriorly; eye frontal, normal in shape and pigmentation; foot ample, stout, rather short; toes about  $\frac{1}{4}$  length of rest of body, almost straight, furcate, style-shaped.

Gosse's description is on the whole accurate; but we are certain that the jaws never protrude.

This misconception has been already explained in the treatment of the genus. We might, however, add that the fleshy projection over the foot is present to a small degree though nothing like so marked as in *D. sterea*.

The short, sharp, furcate toes are usually carried straight behind and rarely approach the back. A lateral view shows that in each toe the ventral edge is slightly recurved, the dorsal almost straight.

The eye is frontal and consists of a simple sphere of red pigment.

The jaws have the incus thin and ending in a fine point. The mallei are also long and thin and **not** crutched.

These two latter points, together with the flexible and graceful body, serve to distinguish it readily from *D. sterea*.

The food of this species is flocculent matter.

*Size.*—Total length  $\frac{1}{170}$  in. ( $150 \mu$ ); toes alone  $\frac{1}{950}$  in. ( $27 \mu$ ); breadth  $\frac{1}{700}$  ( $36 \mu$ ); height  $\frac{1}{635}$  in. ( $40 \mu$ ).

Common everywhere.

*The male*, Pl. I. fig. 4a.—Early in July 1902, Mr. C. F. Rousselet sent a small quantity of moss which contained hundreds of females and a large quantity of males, from which fig. 4a was made.

It is a very hyaline, soft, restless male, contorting itself into a variety of form which it is impossible to represent in one drawing. The drawing has been made from an average form not so fully



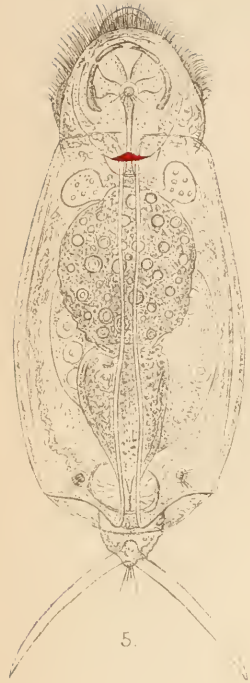

5.



5a.

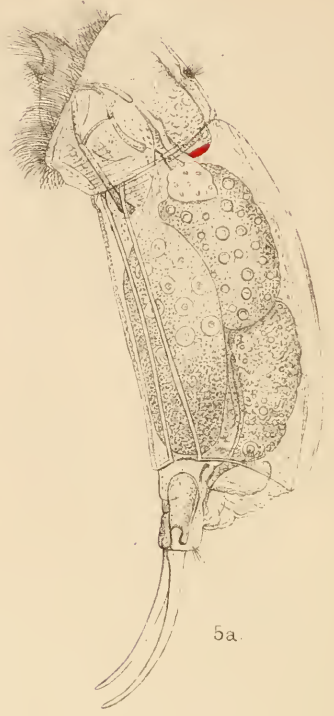

5a.



6

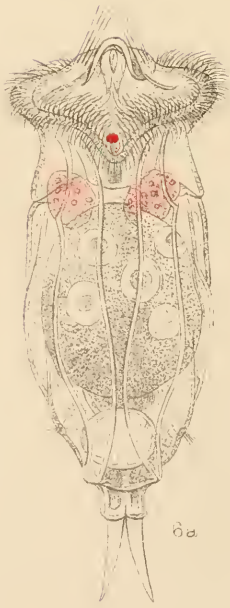

6a



7

FR Dixon Nuttall del ad nat.

West Newman lith

Diaschizae.

extended as when the animal swims freely. It has a frontal eye, slightly marked clefts, short toes, almost straight, slightly recurved. The sperm-sac fills the greater part of the body-cavity.

It is without manducatory organs.

The three antennæ are to be found in their usual situations.

Its length is a little more than half that of the female.

This is the last of the group with a frontal eye. The second group consists of those species with a cervical eye.

### *Diaschiza lacinulata* Müller.

Pl. II. figs. 6 and 6a.

#### SYNONYMY.

*Vorticella lacinulata* Müller.

*Eclissa lacinulata* Schrank.

„ *felis* Oken.

*Furcularia lacinulata* Lamarck.

„ *lobata* Bory de S. Vincent.

*Plagiognatha lacinulata* Dujardin.

*Notommata lacinulata* Ehrenberg.

„ „ Gosse.

„ *ovulum* Gosse.

*Proales gibba* Gosse (nec Ehrenberg).

*Notostemma bicarinata* Bergendal.

*Notommata cuneata* Thorpe.

*Plagiognatha lacinulata* Tessin-Bützow.

#### BIBLIOGRAPHY.

- MÜLLER, O. F.—*Animale. Infusor. Haunniæ*, 1786, p. 292, pl. 42, figs. 1-5.  
 SCHRANK.—*Fauna boica*, iii., 1803, 2, 107, 109.  
 OKEN.—*Lehrbuch d. Naturg.*, iii. 1815, 1, pp. 45, 844.  
 LAMARCK.—*Hist. Nat. d. anim. s. vert.*, ii. 1816, p. 38.  
 BORY DE S. VINCENT.—*Encyclop. method. Vers.*, 1824.  
 EHRENBURG, C. G.—*Die Infusionsthierchen*. Leipzig, 1838, p. 428, pl. 51, fig. 4.  
 DUJARDIN, F. M.—*Hist. Nat. d. Zoophytes Infusoires*. Paris, 1841, p. 652, pl. 18, fig. 6.  
 LEYDIG, F. V.—*Ueber den Bau u. d. syst. Stell. d. Räderthiere*. *Zeitsch. f. wiss. Zool.*, Bd. vi. 1854, p. 38.  
 GOSSE, P. H.—*Manduc. Org. in class Rotif.* *Phil. Trans. Roy. Soc. London*, 1855, p. 432, pl. 17, figs. 32-34.  
 BARTSCH, S.—*Die Räderth. u. ihre bei Tübingen beob. Arten*. Stuttgart, 1870, p. 35.  
 ECKSTEIN, C.—*Die Rotatorien der Umgeg. von Giessen*. *Zeitsch. f. wiss. Zool.*, Bd. 39, 1884, p. 364, pl. 24, fig. 22.  
 EYFERTH, B.—*Die einfachsten Lebensformen*. Brunswick, 1885, p. 107, pl. vii. fig. 18.  
 BLOCHMANN, F.—*Die mikrosk. Pflanz. u. Thierw. des Süßwassers*. Brunswick, 1886, p. 100.

- PLATE, L.—Beiträge z. Naturg. d. Rotator. Jen. Zeitsch. f. Naturw., Bd. 19, N.F. Bd. 12, 1886, p. 23, pl. i. fig. 6.
- TESSIN-BÜTZOW, G.—Rotatorien d. Umgeg. v. Rostock. Arch. 43, d. Frid. Naturg. i. Mechlbg., 1886, p. 149, pl. i. fig. 9.
- HUDSON & GOSSE.—The Rotifera. London, 1889, vol. ii. p. 26, pl. 17, fig. 9; p. 37, pl. 18, fig. 8; Suppl. p. 20, pl. 31, fig. 7.
- THORPE, V. GUNSON.—New and Foreign Rotif. Journ. Roy. Micr. Soc. London, 1891, p. 305, pl. 7, fig. 5.
- BERGENDAL, D.—Zur Rotatorienfauna Grönlands. Lund, 1892, p. 70, pl. 2, fig. 18.
- BILFINGER, L.—Zu Rotatorienfauna Württembergs. Zweiter Beitr. Jahresh. d. Vereins für vaterl. Naturk. in Württ., 1894, p. 44.
- KERTESZ, KALMAN.—Budapest es Kornyekenek Rotat.-Faun. Budapest, 1894, p. 30.
- LEVANDER, K. M.—Materialien z. Kenntn. d. Wasserfauna, etc. Act. Soc. pro Fauna et Flora fennica. Helsingfors, 1894, xii. No. 3, p. 43.
- SCORIKOW, A. S.—Rotat. d. env. d. Kharkow. Kharkow, 1896, p. 86.
- STENROOS, K. E.—Das Thierl. im Nurmjarve-See. Act. Soc. pro Fauna et Flora fennica. Helsingfors, 1898, xvii. No. 1, p. 156.
- WEBER, E. F.—Faune Rotator. d. Bassin d. Léman. Genève, 1898, p. 545, pl. 18, figs 5-7.

For the above bibliography we are indebted to the last work quoted.

*Spec. Char.*—Body round, back highly gibbous, venter flat; head long on the dorsum in proportion to body; neck well marked; face sub-prone; corona extending obliquely down to the ventral side of neck; lorica very transparent, normal diaschiza type; dorsal cleft very wide, especially in front; lateral cleft also wide; eye cervical, on the end of the brain; foot short, scarcely projecting from lorica; toes about  $\frac{1}{4}$  length of rest of body, decurved, slightly outcurved.

This is the oldest of our genus, having been described by Müller in 1786. His original description is remarkably good, accurate, and detailed, considering the early date and the poor lenses which he must have had. Strange to say, he did not fall into the error into which several subsequent authors have fallen, viz. that of stating that the jaws protrude. He describes the arrangement of the "lacinulæ" or flaps as such that "apertura rosacea apparet."

Ehrenberg's figure is good, his description inaccurate as to the jaws, and he transfers it to the genus Notommata.

Gosse retained the generic name Notommata. He fell into the error of supposing that "the tips of the rami were habitually projected from the front." These, as we have already explained in treating of the genus, are really the projecting lips of the buccal orifice.

Weber follows Gosse in this mistake, but adds a note from Mr. C. F. Rousselet, which gives a correct view of the case. He rightly, however, transfers this species to the genus Diaschiza.

This species is exceedingly abundant, and is to be found in nearly every pond which one visits.

It varies very greatly in size from  $\frac{1}{2}\frac{1}{36}$  in. (90  $\mu$ ) to  $\frac{1}{160}$  in. (160  $\mu$ ), and also in shape, some examples being very globular, others more lengthened.

Viewed laterally, it is more or less cuneiform, but the back varies considerably in its rotundity.

Viewed dorsally, it varies from an approximately cylindrical form to a wedge shape, a marked constriction separating the head from the body.

The head is covered up to the face with the usual stiff integument, and is not, as Weber infers, totally illoricated.

The protruding lips of the buccal orifice give the dorsal view of the face that triangular shape to which Weber also refers.

The rotatory organ extends obliquely down to the ventral surface of the head, where it is amply furnished with long vibratile cilia. A bunch of stiff setæ surrounds the buccal orifice.

The lorica is soft and transparent, of the normal type of the genus. The dorsal cleft is easily observed, wide and well marked. Its edges diverge considerably from the back to the front of the trunk. The other clefts, lateral and *ventral*, are broad and conspicuous.

The brain is almost clear.

The eye, which is cervical, and situated on the lower end of the brain, consists of an elliptical mass of red pigments.

The foot is short, and scarcely projects beyond the lorica.

The toes, which are about  $\frac{1}{4}$  the length of the body, vary considerably in size and shape. Sometimes they are almost straight, and can be closely appressed to one another; but as a rule they are slightly outcurved and decurved.

The gastric glands are usually tinted in adult specimens with some shade between brown and pink.

The mastax is normal, with strongly striated muscles.

The jaws have the incus long, and are very robust from a lateral view. The mallei are small and thin.

The stomach is often coloured with food of any colour from ruby red to brilliant emerald green.

In habit "this tiny sprightly atom" frequently (Gosse: "rarely") anchors itself by the mucous secretion of its foot-glands. It has also a pretty habit of jerking itself rapidly from one position to another without weighing anchor.

*Size*.—Total length downwards from  $\frac{1}{159}$  in. (160  $\mu$ ); toes only  $\frac{1}{635}$  in. (40  $\mu$ ); breadth  $\frac{1}{420}$  in. (60  $\mu$ ); height  $\frac{1}{380}$  in. (67  $\mu$ ). Abundant everywhere.

**Diaschiza ventripes** Dixon-Nuttall.

Pl. II. fig. 7.

## BIBLIOGRAPHY.

DIXON-NUTTALL, F. R.—On *D. ventripes*, a new Rotifer. Journ. Quek. Micr. Club, London, April 1901, p. 25, pl. 2, figs. 1-3.

*Spec. Char.*—Body almost cylindrical, dorsum arched, venter slightly concave; head separated by slight constriction, deflexed; neck well marked on dorsal surface; face sub-prone; corona extending down ventral side of head; lorica normal *Diaschiza* type, projecting over base of foot; dorsal cleft well marked, narrow, deep, straight, widening a little aft; lateral cleft well marked, rather wide; eye cervical, double, on the end of brain; foot short, ventral; toes about  $\frac{1}{4}$  length of rest of body, short, sharp, slightly decurved.

This species was described in the *Quekett Journal* (loc. cit.). Since then we have had great quantities of specimens from many ponds in this neighbourhood.

On further acquaintance it turns out to be at times as large as  $\frac{1}{190}$  in. (133  $\mu$ ).

One of the leading features about this rotifer is its arched back, which gives a bent form to the whole body. This, and the ventrally situated foot, are very striking.

The lorica has the appearance of being too large for the trunk, culminating in a clear projection over the foot.

The face is really sub-prone relatively to the head; but as the whole head is depressed by the curvature of the body, it appears quite prone.

The lorica and its clefts are normal.

The eye consists of a pair of red pigmented, hollow hemispheres, fused together at their point of contact.

The foot is short and distinctly ventral.

The toes are remarkably constant in shape and length in this species, being somewhat short and stout and slightly decurved.

The jaws have the incus short, very stout, and specially widened at the fulcrum.

The food consists mainly of diatoms, but also of flocculent matter.

It is slow and graceful in its habits, and seldom found swimming.

The general curve of the body, the projecting lorica, the double eye, the ventral foot, and the short stout incus, mark this species as very distinct from *D. Hoodii* and the rest.

*Size.*—Over all  $\frac{1}{190}$  in. (133  $\mu$ ); toes alone  $\frac{1}{950}$  in. (27  $\mu$ ); breadth  $\frac{1}{600}$  in. (42  $\mu$ ); height  $\frac{1}{480}$  in. (53  $\mu$ ). Well distributed in Lancashire ponds.

‡(Continued on p. 129.)



II.—*An Arrangement for Obtaining Monochromatic Light  
with the Mixed Jet.*

By EDMUND J. SPITTA, F.R.A.S., &c.

(*Read November 19th, 1902.*)

SINCE resolution in the Microscope depends upon two functions, the wave-length of the light used and the N.A. of the objective, it is very obvious, as the latter has reached its practical limit so far as our present knowledge permits us to see, the only hope for increasing the separating power of an objective is to employ monochromatic light composed of the shortest wave-length possible.

The first means which suggests itself to obtain this desirable end is the employment of suitable screens, but it is well known no glass exists, or at present can be made, that is truly monochromatic, save perhaps in the red end of the spectrum, which is of no use for the purpose under consideration. Of course, blue-violet glass is made, but what we mean is that, spectroscopically, the screen passes too much light of other colours, usually red. It has been argued, and in a sense truly, that in photography, provided the sensitive plate is not an orthochromatic one, this does not so much matter, seeing the emulsion is not affected by the red ray, so any blurring effect produced by it would not take effect on the plate, and would not be observable in the developed picture. But the real difficulty lies in the fact that the red image is so disturbing when mixed with the blue-violet, that it seems impossible to focus with the refinement required in photographing minute objects commensurate in size with even perhaps *portions of a single wave-length*. If this be true with photography, it is even more so when using the screen for visual work.

Fluid screens have likewise been tried, but it is found, when they are sufficiently dense to be truly monochromatic, the light is so feeble that the object—anyhow when the mixed jet is the illuminant—is too faint to be well and properly focussed on the focussing screen, especially if the magnification be two or more thousand diameters.

The employment of prisms of great dispersion has also been well tried—in hands, too, far more able than my own—but they have failed for two reasons. One is, that the light produced is so faint and usually so restricted in area, that the coloured beam is only a narrow strip down the field, even when a  $\frac{1}{2}$  homogeneous objective is used; and the other trouble arises from the fact that necessity demands the apparatus to be arranged in a semicircular fashion, and is not capable of being placed in one direct line on an optical

bench, which (without the loss of much time, expense, and trouble) is imperative in photomicrography, and even to a certain extent in visual work.

The position, then, has for some time been one of compelled rest. About four years ago, however, the author, at the Soirée of the Royal Society, first saw the replicas of gratings made by the ingenuity of Mr. Thorp. It may be mentioned that a grating is the name employed for a piece of metal which is ruled with lines so close that they number thousands to the inch. The resulting spectrum is very fine, and although the violet end is characteristically more cramped than is the case with the spectrum formed by a dense glass prism, still it is of sufficient size, if properly manipulated, to fill the substage condenser, even with the use of a  $\frac{1}{3}$ -in. objective. It is, perhaps, needless to state that the spectrum from the grating requires practically the same semicircular arrangement of the apparatus as demanded in the employment of a prism of the same dispersion, and hence its use for the purpose in question is prohibited. Mr. Thorp, however, has discovered a means of coating a metal grating (the one selected for my purpose being  $1\frac{1}{2}$  in. square, with lines about 15,000 to the inch) with a solution he has perfected, and which dries as a solid film. When dry, he is able to strip this film off the metal and mount it on a glass support. These replicas are very perfect, and reflect the prismatic colours with unsurpassable perfection; but in this state, so far as we have as yet described the process, still require the apparatus to be arranged in the semicircular manner previously mentioned in connection with the use of a prism or a metal grating. But they have this difference: being transparent, they *transmit* a spectrum with as much perfection as a metal one *reflects* it.

It is just this difference which constitutes their applicability for the purpose in question. As they can be easily mounted on any glass support, Mr. Thorp now mounts them on corrective prisms of glass of suitable angle, so that he has, after some little trouble, been able to make me one that transmits the violet, blue-violet, and apple-green colours almost in a straight line with the incident light. This enables one to use them with the ordinary optical bench, and so they can be employed both for visual and photographic purposes without arranging any special form of semicircular apparatus, which is a point of very great importance. They are now commercial, and not at all expensive, some being less in shillings, I think, than the metal gratings cost in pounds.

As to the little arrangement I have completed, the apparatus (fig. 1) consists of a specially short and compact mixed jet made by Mr. Beard to the pattern desired, with an addition to enable the microscopist to "turn the lime" by means of a handle shown in the diagram from the eye end of the Microscope as it stands on the base-board, which is a great convenience for two reasons: first, it

saves the operator frequently jumping up and down from his seat; and secondly, it prevents his eye being thrust often and suddenly into the bright light of the incandescent lime, which is quite sufficient to dull its perceptive faculties for some little time. A black glass window, however, is let into the case covering the jet, through which, if necessary, the lime can be viewed without inconvenience. The light from the lime is caught by a 6-in. compound condenser, which, after passing through one of Zeiss' thick water-baths, is focussed on a slit, the size of which is not of much importance, the one in use being about 17 mm. long and 4 wide. Focussed upon the other side of the slit is a lantern-lens of 5-in. focus, thus forming a collimator from which issue parallel rays upon the film mounted on its corrective prism. This prism is mounted on a table which revolves on its vertical axis, graduations of a coarse description being added for convenience. All these details are mounted on Zeiss' saddles to slide on the optical bench, and when the suitable position is found for each of them they can be locked at will. From the prism the rays fall upon the substage condenser of the Microscope, the instrument being bent at right angles so as to stand on the little table fixed to the base-board upon which everything rests. Everything save the Microscope is covered in by a suitable casing, which can be easily opened if required, dia-

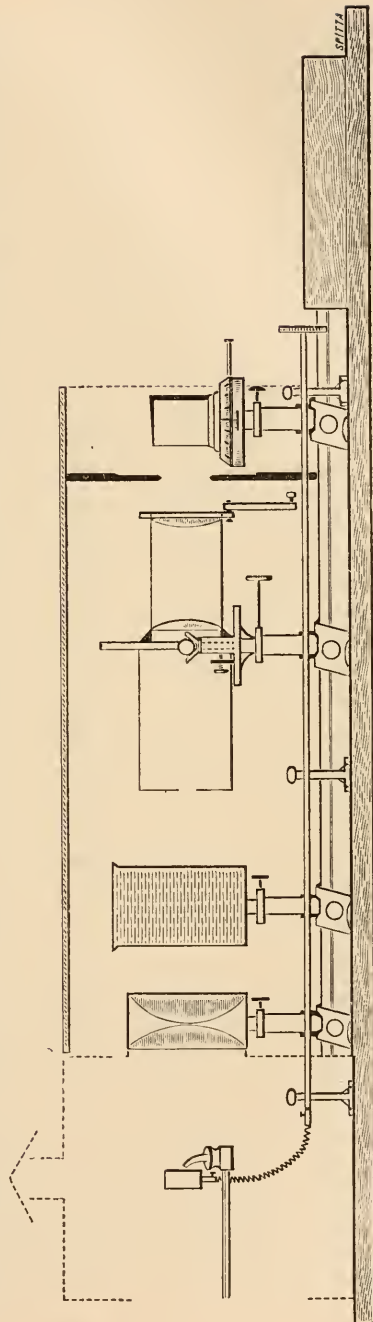

FIG. 1.

phragms, &c. being added to complete the efficiency of the apparatus as a whole.

It must be here remarked that for the full efficiency of this arrangement to be secured it is absolutely necessary to obtain critical light *most carefully*. For this reason it may be well to mention how this may be most easily accomplished.

Having removed the film-prism and its saddle from the optical bench, the collimating lens is covered with a slip of black glass, shown in the diagram, so that the eye may not be blinded. This should not be forgotten, for the direct light is *most intense*. Owing to most condensers being made to work with more or less diverging beams, such as those derived from a lamp, and not with parallel rays such as in this case issue from the collimator, it is in most cases necessary to *raise* the condenser nearer the specimen than would be the case if a lamp at a few inches were used. In consequence, especially if the slip be a thick one, it may in some instances be impossible to raise the condenser high enough to see the markings on the lime—in other words, to obtain critical light. To do this properly, then, a 7 to 10-in. common negative spectacle lens must be placed immediately beneath the condenser, which rectifies the trouble and enables the microscopist to obtain the critical images without further difficulty. In my case, Mr. Conrady computed and made me a special front to his condenser, which does away with the necessity. With respect to the selection of an immersion condenser, it is most important to obtain one with as large an aplanatic cone as possible, because, failing this, less oblique light can be profitably used, and the final resolution is affected most seriously. It should be recollected, too, that as the spectra from the horizontal *as well as* the transverse lines *must* both at one and the same time be seen in the back lens of the objective (the eye-piece being removed), it is obviously most important to use one with as high a N.A. as possible, for a great difference is noticeable in the resolving power even if a 1.30 apochromatic be used instead of a 1.40.

Seeing that one of the great difficulties hitherto experienced in using monochromatic light with a mixed jet is to get enough of it, so it is only fair to point out that the best limes procurable should be used, but perhaps it is more important still to obtain the purest oxygen. Some oxygen on the market contains a large amount of impurities, chlorine, air, and so on, probably through carelessness in its manufacture; hence, while admitting that others may make as good, the author has no hesitation in recommending the gas produced by Brin's Oxygen Co., for the simple reason that, owing to the company frequently testing it during manufacture in every process, and finally before filling the cylinders, it is sent out practically pure.

## NOTE.

*A Two-speed Fine Adjustment.*

By EDWARD M. NELSON.

To make use of a common but apt expression, we may say that the two-speed fine adjustment has "come to stay." I have not been able to hunt up back volumes to discover the first inventor of a two-speed fine adjustment, but if we go back only as far as 1899, and turn up page 139 of the *Journal* for that year, we shall find a new Microscope figured and described by Mr. Keith Lucas, its designer. The principal novelty in this Microscope lies in the peculiar form of its coarse and fine adjustments. Probably it would be more accurate to describe this instrument as a Microscope possessing a two-speed fine adjustment and no coarse adjustment, and this is the exact point where this ingeniously designed Microscope fails—it lacks a coarse adjustment, its so-called coarse adjustment being in reality a quick fine adjustment.

In 1901 we had three forms of two-speed fine adjustments brought by Mr. Ashe to the notice of the Quekett Microscopical Club. Two of these were of the differential screw type, and all of them were very skilfully designed. Since then we have had a new two-speed fine adjustment brought before us in the Males-Watson Microscope, exhibited here at the June Meeting, 1902. This is the only two-speed fine adjustment I have had the opportunity of practically testing; its performance was not only perfectly steady, but it was prompt in its action as well.

It would seem that the best kind of two-speed fine adjustment will eventually settle down to some sort of combination of levers, for an arrangement of screws working within screws will require fine finish and careful adjustment if the movement is to be steady and prompt. Now, to my somewhat fastidious eye, the Males-Watson device is susceptible of improvement in two minor points.

First, the slower movement is actuated by a micrometer-screw placed in the middle of the horizontal arm, and the quicker or rougher adjustment has its screw placed at the posterior end of the arm immediately over the limb, i.e. the position of greatest steadiness.

Now it seems reasonable that if the positions of these were reversed, and the coarser movement were placed at the weaker point, and the more delicate movement at the steadiest point of the arm, an undoubted improvement would be effected.

Again, the difference between the speeds in the two-speed gear fitted to the Microscope exhibited before this Society was not suffi-

ciently great to warrant the trouble and expense of this extra fitting. If, for instance, we could get speeds of, say,  $\frac{1}{500}$  and  $\frac{1}{30}$  for a revolution of each of the respective micrometer-screws, then the full benefit of a two-speed fine adjustment would be at once apparent. Now, as the speed of an ordinary coarse adjustment may be taken as  $\cdot 65$  in. for each revolution of the coarse adjustment pinion, a  $\frac{1}{30}$  will be  $19\frac{1}{2}$  times slower than the coarse adjustment, and  $16\frac{1}{2}$  times faster than the finest. (If the intermediate motion had a movement of  $\cdot 036$  in. for each revolution it would be 18 times slower than the coarse, and 18 times faster than the finest adjustment.)

But in the Microscope exhibited here the intermediate adjustment had a speed of  $\frac{1}{150}$  in. for each revolution, which is three times slower than the fine adjustment of the ordinary Continental Microscope.

Fig. 2 illustrates the proposed alteration, which, like the Males-Watson, consists of a lever of the second order engaging

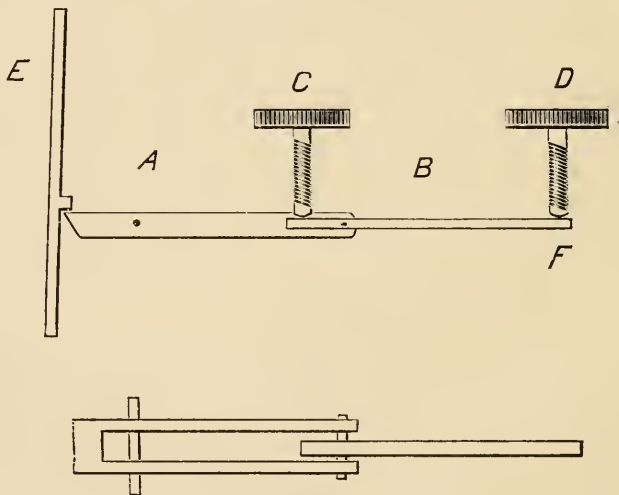

FIG. 2.

with one of the first; the springs at 'E' and 'F' to keep the levers A and B in close contact with the micrometer-screws C and D are not shown.

If, for example, the lever A had a ratio of 2 : 1, and B 4 : 1, and the micrometer-screw C had 15 threads, and that at D 65 threads to the inch, very suitable speeds would be obtained. Both micrometer-screws should be left-handed.

SUMMARY OF CURRENT RESEARCHES  
RELATING TO  
ZOOLOGY AND BOTANY  
(PRINCIPALLY INVERTEBRATA AND CRYPTOGAMIA),  
MICROSCOPY, ETC.\*

ZOOLOGY.

VERTEBRATA.

a. Embryology.†

**Carbonic Acid as a Provocative of Artificial Parthenogenesis.‡—**Yves Delage finds that the ova of starfish just beginning to show signs of maturation may be induced to develop parthenogenetically by being placed for an hour in sea-water charged with carbon dioxide. It is a simple method to make seltzer water with sea-water, and to put the eggs in it, but the results are astounding. Every precaution to ensure the absence of spermatozoa was taken, and more ova began to develop than if spermatozoa had been supplied. The developing ova formed very vigorous blastulæ and gastrulæ and characteristic *Auricularia*-larvæ, quite normal and agile.

**Agency of Carbon Dioxide in inducing Artificial Parthenogenesis.§—**Yves Delage has shown that the presence of this gas in sea-water may induce parthenogenetic development in starfish (*Asterias*) eggs. This gas is acid, anæsthetic, and inhibitory to respiration; and it increases the osmotic pressure of the water. Experiments go to show that it is not in virtue of any of these properties that it induces parthenogenesis. To say that it acts as a specific stimulant or as an acceleratory catalytic is merely to use words. A hint is found in the fact that the experiment with  $\text{CO}_2$  only succeeds when the ova are subjected to the unusual environment just as they are about to exhibit maturation-division or just before the reduced nucleus has passed into a state of rest. The poisonous action of the  $\text{CO}_2$  inhibits further procedure, but when the eggs are replaced in ordinary sea-water they recover and go on with their division, it may be on somewhat different lines.

\* The Society are not intended to be denoted by the editorial "we," and they do not hold themselves responsible for the views of the authors of the papers noted, nor for any claim to novelty or otherwise made by them. The object of this part of the Journal is to present a summary of the papers as *actually published*, and to describe and illustrate Instruments, Apparatus, &c., which are either new or have not been previously described in this country.

† This section includes not only papers relating to Embryology properly so called, but also those dealing with Evolution, Development, Reproduction, and allied subjects.

‡ Comptes Rendus, cxxxv. (1902) pp. 570-3.

§ Tom. cit., pp. 605-9.

Delage's general view is that the agents which induce artificial parthenogenesis act as temporary poisons.

**Artificial Parthenogenesis.\***—C. Viguier notes that the development or commencement of development of eggs which would not spontaneously develop, is now known to be induced by (1) changes in surrounding temperature; (2) mechanical excitation, notably shaking; (3) exposure to various solutions, which may have a directly chemical, or osmotic, or catalytic action; and (4) to the introduction of spermatozoa of a different species from the ovum.

Viguier has experimented with *Sphærechinus*, *Toxopneustes*, and *Arbacia*, and emphasises the absence or rarity of artificial parthenogenesis under the above modes of treatment. Only the third mode gave any positive results.

**Reappearance in Offspring of Lesions Artificially induced in the Mother.†**—A. Charrin, G. Delamare, and Moussu find that the progeny of pregnant rabbits and guinea-pigs, subjected to laparotomy, sometimes show congenital hepatic or renal lesions (congestion, hæmorrhage, degeneration, &c.). The state of the diseased organ in the offspring is precisely analogous to that of the artificially deteriorated organ in the mother.

The authors conclude that "characters acquired by the mother may be transmitted to the offspring. This transmission, this selective action at a distance, this vital induction, this influence of a parent's organ on the corresponding organ of the offspring, is due to the action of soluble substances." Thus they explain the reappearance in successive generations of congenital dystrophy of liver, kidneys, &c. That the phenomena are in the strict sense facts of inheritance is another question.

**Note on Oogenesis in Mammals.‡**—Hans von Winiwarter discusses the so-called "Balbiani's body" (*Nebenkern*) in the oocytes of man and rabbit. The *Nebenkern* in the human ovum is an idiozome and equivalent to a similar body in the oocyte of the rabbit; but the Balbiani's body of the rabbit's ovum is not an idiozome; it is a quite distinct and accessory chromatoid structure.

**Retrospective Changes in Ovarian Follicle of Amphibians.§**—A. Bühler finds that these begin with two almost contemporaneous processes:—a chromatolytic dissolution of the germinal vesicle, and the penetration of follicular epithelium and some leucocytes into the ovum. The epithelial cells have most to do with absorbing component parts of the ovum, especially yolk and pigment, the dissolved results of which are removed via the blood-vessels. While the whole is being reduced in this way, there is an intrusion into the follicle of connective tissue from the theca, and this, as shrivelling proceeds, replaces the degenerating follicular epithelium, which finally disappears into the stroma ovarii.

**Germ-Cells and Germinal Continuity.**—John Beard read a paper on this subject to the Royal Physical Society, Edinburgh, on November 24. The following abstract is published in the billet. The germ-cells of

\* Comptes Rendus, cxxxv. (1902) pp. 197-9.

† Tom. cit., pp. 189-91.

‡ Anat. Anzeig., xxi. (1902) pp. 401-7 (3 figs.).

§ Morph. Jahrb., xxxi. (1902) pp. 85-103 (2 pls.).



*Raja batis* are products of the egg-cleavage. Their number is a definite one, 256 in the male, 512 in the female. As they arise before an embryo, on the unfolding of this latter they have to immigrate into it. Only a percentage of them find the way to the normal position, the germinal nidus. The rest, from 10 p.c. to 28 p.c., occupy various abnormal positions, and many of them degenerate in these. Hardly an organ in the vertebrate body is free from possible "infection" by such aberrant germ-cells. In this way one comes to recognise in them the hypothetical "lost germs" of pathologists, but these are entities quite different from anything ever imagined by any pathologist, and, moreover, structures endowed with far more potent attributes for mischief than any "lost germs" ever conceived of by pathologists.

Such aberrant germ-cells are undoubtedly the seed of those tumours, identified by Wilms as rudimentary embryos or "embryomas." But in mammals the development of such an aberrant germ-cell, or of its products, at a later period of life gives rise to something lying in a different portion of the life-cycle, to a pathological asexual generation, or chorion. This is a structure with indefinite unrestricted process of growth, and the tumours generally classed as carcinomatous are of this nature. The problem of cancer is thus a very simple one of embryology.

**Spermatogenesis in Sparrow.\***—G. Loisel sums up his researches on this subject. He follows the history of the germinal cells through their successive stages,—spermatogonia, spermatocytes, spermatids, and spermatozoa. The cells of Sertoli are hypertrophied germinal cells, in which the function of internal secretion is dominant. They show three successive phases analogous to the phases in spermatogenesis. Loisel lays particular emphasis on the cytogenic function of the testis (awkwardly called "morphological secretion", and the glandular function (chemical secretion) which produces, especially in spring, a fluid containing iron,—an excitant to the seminal epithelium.

**Dimorphism of Spermatozoa.†**—Fr. Meves has continued his investigation of this interesting subject. He gives an account of the spermatogenesis in *Paludina*, which has normal "hair-like" and peculiar "worm-like" spermatozoa. The former may be called "*eupyrene*" [ $\epsilon\acute{\iota}$  and  $\pi\nu\rho\acute{\eta}\nu$  = nucleus], and the latter "*oligopyrene*," for they have little nuclear material. In the case of the Lepidopteron *Pygæra*, the term "*apyrene*" is more appropriate for the peculiar type of spermatozoa, corresponding to the oligopyrene type in *Paludina*. Meves gives an account of the spermatogenesis in both cases.

We have brought this paper—which deals with a Gasteropod and an insect—under the general heading "*Embryology*," and we restrict ourselves to noting that the author discusses the dimorphic spermatogenesis, the problem of "reduction," the nomenclature of cell-centres, and the very difficult question as to the possible function of oligopyrene and apyrene spermatozoa. As to the last point, Meves is very cautious, but he is evidently disinclined to regard the forms with little or no nuclear material as functionless.

\* Journ. Anat. Physiol., xxxviii. (1902) pp. 112-77 (4 pls. and 11 figs.).

† Arch. Mikr. Anat., lxi. (1902) pp. 1-84 (8 pls. and 30 figs.).

**Spermatogenesis in Phalangista vulpina.\***—K. von Korff gives a full account of the spermatogenesis in this Marsupial. Most remarkable is the threefold movement of the nucleus before it assumes its definite position. On the whole, the other parts of the spermatozoon are formed as in other Mammals. The author also describes the remarkable spermatozoa of *Didelphys* which have been inaccurately pictured elsewhere.

**Prepotency in Polydactylous Cats.†**—H. B. Torrey describes a family history of cats from which it appears that the total number of digits, as well as the number on each manus and pes went on increasing from generation to generation (three generations), although one parent (the male) was always normal. All the forms were descended from a stray female cat of unknown pedigree, which had six toes on each manus and five toes on each pes.

**Biometric Evidence bearing on Theory of Limb-Origin.‡**—Bashford Dean has made growth measurements of young stages of the Cestraciont shark *Heterodontus japonicus*, and finds confirmation of the fin-fold theory of the origin of Vertebrate limbs. The pectoral fin is subject to changes with respect to the gravity centre, i.e. physical changes which cause it to become more highly specialised than the ventral fin. The latter is conservative, like the unpaired fins. There is no evidence that the ventral fin is a structure which has shifted its position from in front hindward. In various other ways the author finds confirmation of the Balfour-Thacher theory.

**Notes on Development and Structure of Bradypus.§**—L. Simon describes the respiratory system and vascular system of *Bradypus tridactylus marmoratus*. He gives particular details of the arterial branchial plexus, which is almost completely developed in the embryos, and discusses its physiological significance. Two rudimentary teeth—true incisors—were found in the lower jaw, and reasons are given for changing the adult formula from  $\frac{005}{004}$  to  $\frac{014}{004}$ . A slightly developed “enamel-organ” occurs, but no *Schmelz-Belag*; and no evidence of diphyodont dentition was found. Sebaceous glands, whose presence has been denied, are well developed. In regard to the placenta, the author entirely confirms the results of Klinkowström.

**Development of External Body-Form.||**—Carl Rabl has given us the first part of an atlas displaying beautifully the stages in the development of the form of Vertebrates—Mammals in the first instance. He calls most of the previous delineations “caricatures,” or useless, and the models *scheusslich*. In dealing with embryos he has used platinum-chloride-sublimate or picric-acid-sublimate, and he has stained them with borax-carmin. The results in lithograph are very fine.

\* Arch. Mikr. Anat., ix. (1902) pp. 232-60 (2 pls. and 4 figs.).

† Science, xvi. (1902) pp. 551-5.

‡ Amer. Nat., xxxvi. (1902) pp. 837-47 (1 fig.).

§ Arch. Naturges., lxxviii. (1902) pp. 239-61 (2 pls.).

|| ‘Die Entwicklung des Gesichtes. Tafeln zur Entwicklungsgeschichte der äusseren Körperform der Wirbeltiere,’ Leipzig, 1902, vi. and 21 pp. and 8 folio pls.

**Skeletal Changes in Flat-Fishes in the Course of Development.\*—**

O. Thilo discusses these partly from the standpoint of one accustomed to deal with mechanical problems, and partly from the standpoint of an ophthalmologist. The result is a very interesting essay, to which we cannot do justice in this brief summary. Why do flat-fishes swim on one side? This is the natural result of a change in body-form, and has associated with it a number of remarkable changes—extension of median fins to the head, forward displacement of anus, degeneracy of paired fins, deformation of the urohyal, degeneration of swim-bladder, and migration of one eye.

What forces influence the migration of one eye? There are traction-forces due to the eye-muscles, and *Stützkräfte* due to ossifications in the vicinity of the eye, and to the influence of the migrating eye on its still cartilaginous skeletal surroundings.

**Development of Vertebrate Lung.†—**Fanny Moser has studied this in Amphibians, Reptiles, Birds, and Mammals. In every case the principle is the same:—(a) there is a general increase in size by proliferation in the tissues; and (b) there is a special increase of the endodermic epithelium which, as the intrapulmonary bronchus, grows into the solid connective tissue around it.

If the connective tissue is loose and sparse, the increase of the internal epithelium is associated with a direct and diffuse general out-pushing of the wall, and with an enlargement of the intrapulmonary bronchus (as in Amphibia). If the connective tissue is thick and resistant, the epithelial proliferation is localised at particular areas, and results in bud-like outgrowths insinuated into the connective tissue.

Certain parts of the wall that are very resistant to expansion project inwards as if they were septa. The number of buds of the second order decreases as we ascend the Vertebrate series, and the mass of connective tissue increases. Thus the result tends to be a system of long, narrow canals penetrating a thick connective-tissue-sac (Birds and Mammals).

The branching system of the canals within the lung is always monopodial. In every lung there is demonstrable—on to the distal end—a principal canal, the intrapulmonary bronchus (mesobronchus, Stammbronchus, bronche souche, &c.), the direct continuation of the extrapulmonary bronchus.

**Solution of the Eel Question.‡—**Carl H. Eigenmann has come to the following conclusions:—(1) Both male and female eels migrate to the ocean during October to January. (2) The female migrants of this period probably deposit the eggs that are found on the surface during the following August to January. (3) Female eels never mature in shallow water; according to Grassi, maturity occurs at a depth of 500 metres. (4) The eggs float,—according to Raffaele and Eigenmann at the surface, according to Grassi at a great depth. (5) The larva differs markedly from the *Leptocephalus*-stage, and the latter from the adult. (6) The young eel found entering the stream is the result of a meta-

\* Zool. Anzeig., xxv. (1902) pp. 305–20 (19 figs.).

† Arch. Mikr. Anat., lx. (1902) pp. 587–668 (4 pls and 3 figs.).

‡ Trans. Amer. Micr. Soc., xxiii. (1902) pp. 1–18 (4 pls.).

morphosis through a *Hemichthys*-stage. (7) The young eels enter the streams during spring, about two years after their parents entered the sea.

Against these conclusions must be placed what we do not yet know. We do not know the history between the larva of 15 days and the *Leptocephalus* stage; we are uncertain in regard to the egg and the early development; we do not know whether the eggs are normally or only occasionally pelagic; we are unaware of the normal habits of the *Leptocephalus*; we have not yet secured a female with eggs larger than 0.27 mm. in diameter—far from maturity; the question whether the eel ever breeds in fresh water must be still considered undecided.

#### b. Histology.

**Text-Book of Comparative Histology.**\*—K. C. Schneider has done a good piece of work in writing his text-book, which, apart from Opper's large treatise (confined to the alimentary tract), is the first comprehensive treatise on comparative histology since Leydig's classic work published about fifty years ago. The first part of the book is general cytology and histology; the second part—called *Architektonik*—is really general morphology; the third and largest part gives an account of the minute structure of the tissues from Sponges to Vertebrates.

**Molecular Structure and Histology.**†—M. Heidenhain seeks, in a somewhat difficult essay, to show that the minute structure of muscle-fibrils—both in transverse and longitudinal section—admits of being interpreted in terms of molecular architecture.

**Theory of Cell-Division.**‡—A. Giardina expounds what may be called a chemico-physical theory of cell-division. He supposes currents of diffusion from the centrosome,—currents of specific substances which have a chemotropic, chemotactic, action on the hyaloplasm. The karyokinetic figure is not a figure of lines of force, but a figure of lines of diffusion in two distinct fluids, in which spindle and aster represent two distinct dynamic systems. The function of the nucleus is not active, but passively regulative. Most important is the centrosome, which acts as a centre of diffusion.

**Trophospongium of Nerve-Cells and Pancreatic Cells.**§—E. Holmgren has previously described intracellular canaliculi (*Saftkanälchen*) in various kinds of cells. In close association therewith are the intracellular nets, which he calls *trophospongia*, well seen, for instance, in the spinal nerve-cells of the rabbit. From the multipolar "intra-capsular" cells, whose protoplasmic processes surround the nerve-cell proper like a basket, there arise fine branches which penetrate the nerve-cell and form an intracellular network or trophospongium. Similarly in the glandular cells of the salamander's pancreas, there is an intracellular net, restricted to the region between the nucleus and the gland-lumen.

\* 'Lehrbuch der vergleichenden Histologie der Tiere,' Jena, 1902, 8vo, xiv. and 988 pp. and many illustrations.

† Anat. Anzeig., xxi. (1902) pp. 391-8 (1 fig.).

‡ Tom. cit., pp. 561-81 (4 figs.).

§ Arch. Mikr. Anat., lx. (1902) pp. 669-80 (1 pl. and 3 figs.).

They are not endogenous, but exogenous in origin, representing the terminal branches of processes from the adjacent *Korbzellen* and *centro-acinous* cells.

**Criticism of Theories of Nuclear Structure.\***—K. Tellyesniczky points out that the visible structural complexities which have been described in the nucleus do not in all probability correspond to the living reality. There is no structural theory that helps much in the interpretation of nuclear division and other activities. He discusses particular structures—lanthanin, linin, and so on—in relation to the effect of different reagents.

**Structure of Cartilage-Cells.†**—A. Pensa has demonstrated on the cartilage-cells (i.e. of guinea-pig), a body like a centrosphere (with one centrosome or more), and a reticular apparatus which is in apparently direct relation therewith.

**Nuclear Changes in Striped Muscle-Cell of Necturus.‡**—A. C. Eycleshmyer gives a preliminary account of remarkable changes in quantity, quality, and distribution of chromatin during the various phases of cytoplasmic differentiation. He emphasises the apparent correlation of the nuclear changes with phases of cytoplasmic activity. He asks if the nucleus of the muscle-cell, like that of the gland-cell, builds up and gives off chromatin material which plays an important rôle in cytoplasmic metabolism, and suggests that the dark band of the muscle-fibril may be derived from nuclear chromatin.

**Endings of Nerves in Salivary Glands.§**—A. Pensa finds that the nerves going to the salivary glands in cat, rabbit, &c. end in an endocellular reticulum.

**Muscular Terminations of Nerve-Fibres.||**—A. Perroncito makes another contribution to this much discussed subject. He describes, especially in reference to human muscle, the ultimate terminations of the motor fibrils in relation to the muscular tissue.

**Formation of Zymogen in Gastric Glands of Adder.¶**—L. Launoy finds that the formation of zymogen in the granular gastric cells is quite independent of reflex or mechanical stimulus, and may even occur when the digestive canal has been for a long time in a resting state during fasting. The elaboration of the zymogen-granules is endonucleolar. The transformation of the zymogen into ferment is accomplished in the cytoplasm, and this part of the procedure is reflex—depending on the mechanical, physical, or chemical stimuli which act upon the cells.

**Femoral Glands of Lizards.\*\***—Fr. Schaefer gives a detailed account of the occurrence and structure of the femoral glands in Lacertilia. The secretion which protrudes from the glands consists of cornified or partly cornified stuff in *Lacerta* and *Acanthodactylus*; in *Sceloporus acanthinus*

\* Arch. Mikr. Anat, lx. (1902) pp. 681-706.

† Rend. R. Ist. Lombardo, xxxiv. (1901) pp. 443-7.

‡ Anat. Anzeig., xxi. (1902) pp. 379-85 (3 figs.).

§ Rend. R. Ist. Lombardo, xxxiv. (1901) pp. 362-8 (1 pl.).

|| Tom. cit., pp. 164-70 (4 figs.).

¶ Comptes Rendus, cxxxv. (1902) pp. 195-7.

\*\* Arch. Naturges., lxviii. (1902) pl. 27-64 (2 pls.).

it is more like sebaceous matter without trace of horn. In some cases, e.g. *Lacerta agilis*, there is an actual separation of material from the mouth of the gland, quite apart from moulting. At the breeding season there is in the males a specially active cellular modification in the glandular body.

The femoral glands arise from an insinking in the rete Malpighii into the connective tissue, and a proliferation of the cells of the insunk tissue. They may be called cytogenous glands—*glandulæ celluliparæ*—and may be placed nearest sebaceous glands.

### c. General.

**Vital Rhythm.\***—Messrs. Vaschide and Cl. Vurpas deduce from studies on the vaso-motor system, and from studies of abnormal cerebral conditions (insanity, general paralysis, mania, anencephaly, &c.) that life is characteristically rhythmic. There is a periodic alternation of forceful action (“*dynamogeny*”) and repose. The higher nerve-centres have the rôle of a psycho-dynamic co-ordinator, regulating the living machine to a relatively stable equilibrium, in virtue of their superior and quite specific property of inhibition.

**Comparative Anatomy of Vertebrates.†**—R. Wiedersheim has brought out a thoroughly revised (5th) edition of his well-known *Grundriss*, with more figures, more bibliography, more summaries, and necessarily more pages. In short, it is no longer a *Grundriss*, but much more, and the *Grundriss* will be replaced by a smaller work, an ‘Introduction to the Comparative Anatomy of Vertebrates.’

**Colours of Fishes.‡**—D. S. Jordan contributes an interesting essay on this subject. The colours of fishes are in general produced by oil-sacs or pigment-cells beneath the epidermis or in some cases beneath the scales. Certain metallic shades, silvery blue or iridescent, are due to the deflection of light from the polished skin or the striated surface of the scales. Certain fine striations give iridescence through interference.

The *ground colour* is more subject to individual or local variation, usually within narrow limits; the *markings* are more subject to change with age or sex, but are more distinctive of the species.

The ground coloration most usual among fishes has protective value. Protective markings are also common. In many cases the sexes are differently coloured. Nuptial colours do not appear among marine fishes, but are well known in minnows, dace, and some other fresh-water fishes.

Recognition marks, or what may be plausibly interpreted as such, are frequent, and appear as ocelli, spots, cross-bars, and so on.

In general, coloration is most intense and varied in certain families of the tropical shores, and especially about coral reefs; but the brilliancy of individual markings of some darters (*Etheostominæ*) and sun-fishes (*Centrarchidæ*) of the streams of eastern N. America is noteworthy. The coral fishes seem to scorn the need of protective coloration, saving

\* *Comptes Rendus*, cxxxv. (1902) pp. 752-4.

† ‘Vergleichende Anatomie der Wirbelthiere,’ Jena, 1902, 8vo, xix. and 686 pp. and 379 figs.

‡ *Amer. Nat.*, xxxvi. (1902) pp. 803-8.

themselves by alertness (*Chaetodon*, *Pomacentrus*) or by burying themselves in the sand (e.g. *Jules gaimardi*), a habit more frequent than has been suspected. The author also alludes to variability in coloration.

**Arsenic in Animals.**\*—G. Bertrand has found minute traces of arsenic in a large number of animals—sponge, sea-anemone, starfish, sea-urchin, holothurian, barnacle, sepia, fish, turtle, stormy petrel, and *Orca gladiator*. In most cases it was diffusely distributed.

In an appended note Gautier remarks that in his researches on terrestrial mammals and on birds, the arsenic was mainly restricted to the ectodermic structures. He found it also in marine and fresh-water green algæ, and he is convinced that the sea-water is itself arsenical.

**Rabbit Pest in Australia.**†—W. Rodier has reprinted a useful pamphlet, which was noted in *Nature*, March 21, 1889, explaining a simple method of dealing with the rabbit pest. His plan is based on the fact that while polygamy favours increase, polyandry does not. Rabbits usually live in a polygamous state. Rodier proposes to convert this into polyandry by catching the rabbits alive and killing all the females, while all the males are turned out again. The males become much more numerous, they harass the females by their constant attentions, they injure their powers of breeding. The plan has worked well at Tambua station, Cobar, N.S.W., and surely deserves a trial, since all other methods have been more or less failures.

**Origin of Paired Limbs of Vertebrates.**‡—Bashford Dean considers the historical or palæontological evidence. As regards Palæozoic sharks, it is most distinctly in favour of the Thacher-Balfour theory of derivation from lateral folds. The oldest forms, acanthodians and cladoselachids, present lateral-fold fins. As the series advances from the lower Devonian, the structures of the biserial archipterygium are gradually acquired. The Carboniferous *Cladodus neilsoni* of Traquair shows for the first time a definite segmentation of the supporting elements of the base of the pectoral fin. Then in the Permian *Symmorium* of Cope, the fin-bases are not only formed, but show apparent fusion in the metapterygial terminal, a condition which would be best correlated with a change of function in the fin. And finally, in the Xenacanthids, the pectoral fin acquires a biserial archipterygium.

The author considers the objections to this conclusion, and points out the difficulties of Gegenbaur's theory.

**Interscapular Gland in Human Embryos.**—Shinkishi Hatai has found in five human embryos a long, narrow, paired organ, lying partly along the neck and partly occupying the scapular region. It has no anatomical connection with the thymus. No trace of it was found in the adult. From its position, as well as from its fatty structure, it seems comparable to the so-called hibernating gland or fat-organ of lower mammals, but on the other hand, the lymphoid structure which seems

\* *Comptes Rendus*, cxxxv. (1902) pp. 809-12.

† 'The Rabbit Pest in Australia, its Cause and Cure,' Sydney, 8vo, 16 pp. See *Nature*, lxvii. pp. 43-4.

‡ *Amer. Nat.*, xxxvi. (1902) pp. 767-76 (1 fig.).

§ *Anat. Anzeig.*, xxi. (1902) pp. 369-73 (3 figs.).

more important than the fatty part, favours its interpretation as a cervical hæmolymp gland. Further investigations are demanded.

**Snake Venoms.\***—W. Hanna gives a general account of snake venoms, and draws particular attention to the differences as to poison-apparatus and venom between the two great divisions—poisonous colubrine snakes, e.g. cobra, and viperine snakes, e.g. Russell's viper or daboia. He discusses the various physiological actions of the poisons, the antitoxic use of serum, and the question of self-immunisation.

**Permeability of Frog's Skin.†**—Angelo Andres and L. Pesci have made a number of experiments relating to the permeability, or, as they say, semi-permeability, of the frog's skin. The permeability or semi-permeability is entirely an epidermic function, and persists for some time after death. In frogs with absent or disorganised epidermis the loss of weight increases in proportion to the density of the surrounding medium. In intact frogs the variations in weight are approximately equal in fluids of equal osmotic pressure.

**Toxotes jaculator in Captivity.‡**—N. Zolotnitsky has some interesting notes on the habits of this fish. He remarks on their inability to survive high temperature, on their sensitiveness to changes of temperature, on the mobility of their eyes, on the accuracy of their aim with their water-jets, and on their quickness to learn how to deal with new kinds of food. Thus a blood-worm which clung to the sides of the aquarium and could not be caught, was blown off into the open water and then captured. Zolotnitsky regards *Toxotes* as the most intelligent fish he has as yet had to do with.

**Eating Habits of Galeopithecus volans.§**—Nelson Annandale has some interesting notes on a captive female specimen with a newly born young one. From the way in which it drew the pulp of a banana into its almost closed mouth with its tongue, so that the food mostly passed through the openings in the incisors of the lower jaw, the author was led to conclude that the pectinate teeth act as a strainer by means of which fibres and seeds are prevented from entering the food-canal.

**Adrenaline.||**—Dr. Batelli describes his method of extracting the active substance of the suprarenal capsules which Takamine has called "*adrenaline*." Experiments show that the toxic effects and pressure-effects produced by extracts of the suprarenal bodies are due to this substance, adrenaline, to a large extent at least. But he has not been able to show conclusively that adrenaline passes from the organs which produce it into the blood.

**Hæmatolytic Function of Spleen.¶**—L. Lapicque transfused blood into dogs, and, as is well known, the supernumerary corpuscles were destroyed in a few days. He tried to discover if this was modified by splenectomy. His result was that the suppression of the spleen made

\* Trans. Liverpool. Biol. Soc., xvi. (1902) pp. 471-84.

† Rend. R. Ist. Lombardo, xxxiv. (1901) pp. 976-87.

‡ Arch. Zool. Exper., x. (1902) Notes et Revue, pp. lxxxii.-iv.

§ Proc. R. Phys. Soc. Edinburgh, xiv. (1902) pp. 444-5.

|| Arch. Sci. Phys. Nat., xiv. (1902) pp. 423-5.

¶ Comptes Rendus, cxxxv. (1902) pp. 203-5.



only inconsiderable differences in the hæmolytic function. He inclines to say that the spleen is a relatively unimportant part of a vast hæmolytic system.

**Fibrinogenic Substance in Albumen of Bird's Egg.\***—Armand Gautier finds in white of egg evidence of the existence (1·5 p.c.) of a soluble substance, analogous to the fibrinogen of the blood-plasm and to the myosinogen of the muscle-fibre. Like these, under influences favouring the activity of a specific ferment, it can be transformed into an insoluble stuff (ovofibrin) which slight agitation (not necessary to its formation) separates off in a membranous form. No doubt the same phenomenon occurs elsewhere; it only remains for the organising forces of the cell to dispose this fibrillar material in accordance with the laws which regulate the histological forms of the cell or the tissue.

**Autolytic Processes in Pickled Herring.†**—S. Schmidt-Nielsen has studied the fermentative processes which occur in the curing of herring. He does not deny that the bacteria implicated may be of some practical importance, but he thinks that he has definitely proved that the peculiar "ripening" of the pickled herring is due to autolytic processes, brought about by enzymes previously present in the living muscle.

### INVERTEBRATA.

**Adipogenic Function of Liver in Invertebrates.‡**—Mlle. C. Deflandre has studied the so-called "liver" of various Invertebrates—the snail, the mussel, the crayfish, the starfish, &c.—and finds that this diverse organ has a marked adipogenic function. It is a depot for nutritive reserves, chiefly fats, just as the liver in higher animals is a storehouse for glycogen. The fats are accumulated in days of plenty, and the stores are of use not only to the individual, but to the progeny, for the genital elements get their share.

**Agglutinating and Cilio-phagocytic Organs.§**—L. Cuénot seeks to bring a number of puzzling organs into line. The "urns" of *Sipunculus* differ but little from the "urns" of *Synapta*, and these lead on to the cilio-phagocytic organs of *Nereis*, *Glycera*, *Nephtys*, and *Hirudina*, which again are very like the nephridial filters of *Rhynchelmis*, *Henlea*, and *Branchiobdella*. All have the same function of removing from the cœlom granules of debris and degenerated cells; and in all cases there is a vibratile apparatus which takes an active part in collecting the granules and suspended debris. He suggests that the cilio-phagocytic organs of Polychæts and Hirudinea are derived from pre-existent nephridial funnels, and that the filters of Oligochæts represent a differentiation of nephridial epithelium with phagocytic capabilities.

### Mollusca.

#### a. Cephalopoda.

**Vascular System of Squid.||**—L. W. Williams describes the vascular system of *Loligo pealii*,—the general arrangement of the vessels; the

\* Comptes Rendus, cxxxv. (1902) pp. 133-9.

† Biol. Centralbl., xxii. (1902) pp. 408-12.

‡ Comptes Rendus, cxxxv. (1902) pp. 807-9.

§ Arch. Zool. Expér., x. (1902) pp. 79-97 (5 figs.).

|| Amer. Nat., xxxvi. (1902) pp. 787-94 (5 figs.).

structure of the arteries, veins, heart, and branchial hearts; and the capillary system in particular. The wide distribution of the capillary vessels, the presence of an endothelium around every blood-containing cavity, except possibly the hearts, and the absence of demonstrable lacunæ, all lead to the conclusion that the arterial and venous vessels of the squid are connected by capillaries, so that the vascular system is closed.

#### γ. Gasteropoda.

**Notes on Species of Fulgur.\***—B. Smith communicates some preliminary results of a phylogenetic study of the species of *Fulgur*. The changes in ornamentation agree in general with those noted by the Countess von Linden in regard to other Gasteropods. A plausible pedigree is sketched.

The author describes an abnormal specimen of *F. caniculatum*, apparently due to accident when the shell was young; and he records a series of *F. carica*, in which there was some degree of sexual dimorphism, since the adult males were all smaller than the adult females.

**Recent Researches on Gasteropods.†**—H. Simroth gives a valuable account of recent researches on the structure, relationships, and œcology of Gasteropods. He discusses Kowalevsky's studies on two minute species of *Chatoderma* from the Sea of Marmora; Thiele's conclusion that Molluscs have only a hæmocœl; the interesting work of Stempell and of Biedermann on the nature and origin of the shell; Thiele's theory of Gasteropod torsion; Guiart's system of Gasteropods; the work of Woodward and others on *Pleurotomaria*; Bonnevie's account of the parasitic *Enteroxenos* g. n.; Jordan's account of the locomotion of *Aplysia*; Guiart's study of Opisthobranchs; Kowalevsky's description of the striking form *Pseudovermis paradoxus*; Pelseeneer's studies on Pulmonates; and many other researches, about fifty in all.

**Sex Determination of Gametes in Hermaphrodite Gonads.‡**—P. AnceI maintains, with particular reference to *Helix pomatia*, that the sex-cells are at first indifferent, that those which appear *before* the nutritive elements become male cells (giving origin to spermatozoa), and that those which appear *after* the nutritive elements become ova. He thinks this conclusion may be extended to similar cases; the "cyto-sexual" character of the gametes is determined by the time of their appearance in relation to the appearance of the nutritive cells.

**Opisthobranchs from Gulf of Siam.§**—R. Bergh reports on a collection made by Th. Mortensen on the Danish expedition to Siam (1900). It includes three new Tectibranchs:—*Aplysia immunda*, *Aplysiella incerta*, and *Aclesia ocelligera*; and five new Nudibranchs:—*Idalia plebeia*, *Doriopsis pallida*, *Marionia chloanthes*, *Melibe bucephala*, and *Nossis indica*.

\* Proc. Acad. Nat. Sci. Philadelphia, 1902, pp. 505-7.

† Zool. Centralbl., ix. (1902) pp. 265-305 (4 figs.).

‡ Arch. Zool. Expér., x. (1902) Notes et Revue, pp. lxxxiv.-xciv.

§ Mem. Acad. Danemark, Copenhagen, xii. (1902) pp. 155-218 (3 pls. and 1 map).

### δ. Lamellibranchiata.

**Monstrosities in Bivalves.\***—F. C. Baker notes that in fresh-water forms these are often due to external accidents, e.g. trampling by cattle. They are commonest about fords and shallows. He describes and figures cases in *Lampsilis alata*, *L. ligamentina*, and *Unio gibbosus*.

**Innervation of Mantle of Pecten.†**—L. Boutan describes an independent “*circum-pallial*” nerve-centre which has to do with the sensory structures so greatly developed on the periphery of the mantle of *Pecten*. It is connected with the cerebral and pallio-visceral ganglia, but if the connecting branches be cut, it retains its functional integrity. It is ten times larger than all the three other ganglia combined. The pallio-visceral ganglia also innervate the mantle, excepting the portion known as the “*capuchon céphalique*.”

### Arthropoda.

#### α. Insecta.

**Morphological Significance of Chitinous Cuticle.‡**—Nils Holmgren seeks to show that all vertically striated chitinous structures—of one layer or of several layers—in insects, at least, are morphologically and phylogenetically to be interpreted as chitinised and coalescent ciliary hairs. The chief support of his contention is that all the chitin-matrix cells which he has studied have apically a row of blepharoblasts with which the pillars forming the cuticle are in connection. The same disposition of blepharoblasts in relation to a ciliary fringe is well known. The “*Stäbchensaum*,” or “*Härenchensaum*,” or “*plateau striée*,” e.g. of the gut of *Chironomus*, is homologous with a ciliary fringe. Thus some light is supposed to be thrown on the absence of cilia in Arthropods.

**Insects of the Drift Line.§**—Lætitia M. Snow has studied the insects along and around the line of drift thrown up by the waters of Lake Michigan in the spring of 1902. The collections included 114 species, of which 51 were identified.

“We have here a little community of food-providers and food-obtainers, whose population varies with the season, the wind (probably), the beach conditions, and the relative abundance of the various forms. For example, we found (1) the occurrence was in succession; (2) the population increased apparently at times when an off-shore wind was followed by a lake breeze; (3) it also increased with the temperature; (4) the greatest numbers occurred on beaches of low gradient and of smooth fine sand; (5) the abundance of scavenger forms depended upon the abundance of dead herbivorous and predaceous forms and other refuse; (6) the abundance of predaceous forms depended upon the presence of active scavenger and herbivorous and smaller predaceous forms.”

**Calorimetric Measurements in Reference to Pupæ of Lepidoptera.¶**  
P. Bachmetjew has made a large number of experiments on the specific

\* Trans. Acad. Sci. St. Louis, xi. (1901) pp. 143-6 (1 pl.).

† Comptes Rendus, cxxxv. (1902) pp. 587-9.

‡ Anat. Anzeig., xxi. (1902) pp. 373-8 (5 figs.).

§ Amer. Nat., xxxvi. (1902) pp. 855-64.

¶ Zeitschr. f. wiss. Zool., lxxi. (1902) pp. 550-624 (9 figs.).

heat of dried pupæ, living pupæ, pupal fluid, and on the behaviour of pupal fluids under heat and cold. His experiments relate especially to *Deilephila euphorbiæ* and *Saturnia spini*.

**Innervation of Metacephalic Segment.\***—K. W. Verhoeff describes in detail the nerves of this segment, which corresponds to the maxillipedesegment of Chilopoda, and is otherwise known as the microthorax or "Nacken-segment" in insects. As the result of his researches, he proposes the new order Oothecaria (including Blattodea and Mantodea), which, along with the Phasmodea and the Saltatoria make up the old order Orthoptera.

**Excretory Processes in Insects.†**—Nils Holmgren finds in *Apion flavipes*, one of the Curculionidæ, four long Malpighian vessels and two short acinous glands, which are modified Malpighian vessels. In *Dacytus niger*, one of the Cantharidæ, there are six normal Malpighian tubes, but the female has also 6 club-shaped accessory structures, which may be modified Malpighian tubes.

In both cases the excretory products arise in the nuclei of the excretory cells, pass into the cytoplasm, and are eliminated into the lumen of the organ. The same process was observed after injection with pigments such as methylen-blue.

**Mouth-parts of Insects.‡**—V. L. Kellogg notes that the determination of the homologies of the mouth-parts is as yet far from satisfactory, especially as regards Diptera. There is need for the solid grounding of interpretation on a more complete knowledge of the development. His paper is a contribution towards this end.

**Stridulation of Death's Head Moth.§**—Ruggero Cobelli has made some experiments with *Acherontia atropos*, and finds secure evidence that the stridulation is exclusively due to the rhythmic friction of the two portions of the proboscis, one upon the other. It seems necessary to reject the interpretation of the so-called "voice," which has been given by various entomologists from Dugés onwards. Of "voice," in the strict sense, there is no evidence; according to Cobelli the sound produced is wholly due to stridulation.

**Butterflies of Borderland between North and South America.||**—F. D. Godman and the late Osbert Salvin have enriched zoology by the two volumes here referred to on the Lepidoptera Rhopalocera of Central America. Part of the interest of the work is in its analysis of the results of the meeting of the two contrasted faunas of the Holarctic and Neotropical regions. Prof. Poulton writes: "The whole of the vast mass of material in these and the great series of companion memoirs is a remarkable testimony to the insight of P. L. Sclater, in drawing the

\* Zool. Anzeig., xxxvi. (1902) pp. 20-31 (9 figs.).

† Anat. Anzeig., xxii. (1902) pp. 225-39 (12 figs.).

‡ Amer. Nat., xxxvi. (1902) pp. 683-706 (26 figs.).

§ Verh. Zool.-bot. Ges. Wien, lii. (1902) pp. 572-4.

|| 'Biologia Centrali-Americana. Insecta, Lepidoptera Rhopalocera,' vols. i. and ii. (1879-1901) xvi., 487, and 782 pp. and 112 pls. See Nature, lxvii. (1902) pp. 25-7.

outlines of his regions, of Darwin in laying down the principles of geographical distribution in the *Origin*, and of Wallace in his masterly development of the subject in his great works on the geographical distribution of animals. These principles have been tested by an appeal to the facts collected with consummate skill and care, from the most critical area in the world, and assuredly they have not been found wanting."

**Seasonal Dimorphism in Butterflies.\***—F. A. Dixey gives an account of observations by himself and by G. A. K. Marshall. Thus *Catopsilia pomona* Fabr. (including *C. catilla* Cram.) and *C. crocale* Cram. are phases of one species, which in one part of their range appear to be in relation with the seasons. Similarly *C. pyranthe* L., is conspecific with *C. gnoma* Fabr., in more marked, but apparently not universal correlation with the seasons. Some cases of simultaneous occurrence of dimorphic forms are explained as due to an overlapping at the change of seasons, or lack of differentiation in the climatic conditions.

Marshall has proved by actual breeding the specific identity of six pairs of forms. The final stage can, in many cases, be influenced by the artificial application of heat or moisture during the pupal condition.

**Colour of Silk.†**—D. Levrat and A. Conte have made experiments on *Bombyx mori* and *Attacus orizaba*, and find that an ingested substance, e.g. pigment, can pass from the gut to the silk-glands by the blood. Greenish silk is due to chlorophyll, the spectrum of which was demonstrated in the blood of *Antheraea yama mai*. As Dubois and Blanc have shown, the yellow colour of some silk is directly due to the diet of mulberry leaves.

**Study of an Ant.‡**—Adele M. Field has studied *Stenammas fulvum piceum* for three years. From among her interesting observations, we select the following. There is no regeneration of the antennæ. A single worker may live apparently well in isolation for six months. Familiarity with the nest-aura does not reconcile aliens. The kings have the distinctive odour of their blood-relations. Virgin queens show marked preference or dislike toward certain kings; queens having once mated permit no close approach of an alien king, and do not respond to the attentions of kings of their own lineage; they may drop their wings without assistance from workers; light and warmth appear to be required for the stimulation of the king and queen to mating. Some experiments suggest definite intellectual memory.

The ants in question are very discriminating in regard to the odour of all ants introduced into their dwelling, whether of their own or some other lineage. The hereditary odour descends through the mother, and is unaffected by the father whether of the same lineage or of an alien colony. A cause for the hostility of one colony to another of the same species and variety is a difference of odour, coincident with difference of age in the individuals composing the colony. Many experiments in regard to sensitiveness to light were made.

\* Trans. Entomol. Soc. London, 1902, pp. 189-218 (1 pl.).

† Comptes Rendus, cxxxv. (1902) pp. 700-2.

‡ Proc. Acad. Nat. Sci. Philadelphia, 1902, pp. 599-625 (2 figs.).

**Gynandromorphism in *Hilara wheeleri* sp. n.\*** — A. L. Melander describes in this new species a rather rare anomaly, viz. antero-posterior or "tandem" hermaphroditism. The front part of the body resembled the normal male, while the abdomen was exactly like that of the female.

**Spermatogenesis in *Cybister ræselii*.†** — D. N. Voïnov describes two different modes of spermatogenesis in this insect. They give rise to two kinds of spermatozoa, different in structure, and perhaps different otherwise. The two processes occur at different times of year, but among the elements of one kind there are abortive representatives of the other. Dimorphism of spermatozoa has been noted in some other insects, in *Pygara tricephala* by Meves, and in *Staphylinus* by Holmgren; it also occurs in *Paludina* and elsewhere.

**Malayan Phasmidæ and a Flower-like Beetle Larva.‡** — Nelson Annandale describes the appearance and habits of *Lonchodes* sp., a Malayan Phasmid, which he invariably found standing upon the upper surface of broad leaves, especially on those of the wild Banana (*Musa*), exposed to the full blaze of the mid-day sun. "The insects did not lie along the midrib of the leaf in the characteristic Phasmid attitude of rest, but stood upright, the body being supported on the bent limbs at the height of about an inch above the surface of their resting-place. In this position the red coloration of the insect made it very conspicuous from above, against the pale green of its support; while even from below, its shadow was perfectly visible through the translucent tissues of the leaf."

The author also describes the peculiar larva of a beetle, apparently one of the Endomychidæ, which is covered with white filaments, apparently of a waxy nature, rising from minute papillæ on the dorsal surface of the flat and broad body. "Seen in profile, the larva bore a ludicrous resemblance to a miniature hedgehog, an animal which was also suggested by its gait." It also resembled the head of a species of groundsel, but it was never found associated with this plant.

**Berlese's Bursa in *Acanthia lectularia* L.§** — D. Carazzi gives a description of the "bursa" which Berlese found in the bed-bug, and interpreted as a spermatophagous organ for destroying surplus spermatozoa. Carazzi has not confirmed the interpretation, but he has added to our knowledge of this puzzling structure.

**Larva of Giant Crane Fly.||** — V. L. Kellogg publishes as one of a series of "studies for students" notes on the structure of the larva of the largest known Dipteron—*Holorusia rubiginosa*, whose life-history has not been previously described. It does not occur except on the Pacific Coast, but the account will be found to answer as a guide to the dissection of any other Tipulid larva.

**Cricket of Aquatic Habits.¶** — L. C. Miall and G. Gilson describe *Hydropedeticus vitiensis* g. et sp. n., a cricket found by Gilson in a clear

\* Psyche, ix. (1901) pp. 213-5 (2 figs.).

† Comptes Rendus, cxxxv. (1902) pp. 201-3.

‡ Proc. R. Phys. Soc. Edinburgh, xiv. Session 1900-1901 (1902) pp. 439-44.

§ Internat. Monatschr. Anat. Physiol., xix. (1902) pp. 337-48 (1 pl. and 1 fig.).

|| Psyche, ix. (1901) pp. 207-13 (2 figs.).

¶ Trans. Entom. Soc., part iii. (1902) pp. 281-5 (2 pls.).

and rapid river in Fiji. "Myriads of black specks were seen dancing on the surface of the water. When alarmed, they hid behind stones. They skated on the water, or jumped to a height of about six inches, usually several times in close succession, and were sometimes seen to leap upon very disturbed water. Now and then three or four of the crickets seemed to be playing at leap-frog, and jumping over one another, as if in sport. They were very hard to catch, though several men were employed in capturing them, and very few specimens were secured."

The largest male was 11 mm. long, not including the antennæ, cerci, or wing-tips. The female insect differs most conspicuously from the male in the presence of a rather long, curved ovipositor, and in the quite different pattern of the wing-cover. It seems necessary to recognise the genus as distinct, and as belonging to the tribe Trigonididæ, among which it is distinguished by the male elytron being partly membranous and altogether unlike that of the female, but without functional stridulating organ, while the hind tibia bears two series of articulated spines.

**Spermatogenesis of Locustidæ.\***—C. E. McClung describes in detail the spermatocyte divisions in *Xiphidium*, *Orchesticus*, *Anabrus*, and other Locustidæ. We quote the tenth and last paragraph of his summary. "From each first spermatocyte there are formed, by two divisions, four spermatids, of which two are distinguished from the remaining pair by the possession of an extra chromosome in addition to the number—sixteen—common to them all. Both classes undergo a like series of transformations by which they become mature spermatozoa. These are necessarily of two kinds; and it is believed that those containing the accessory chromosome, in the act of fertilising the egg, determine that the germ-cells of the embryo shall be sexually male, or like themselves, while those from which it is absent are unable to impress their sex upon the egg and assist in producing female embryos." We have here another contribution to the interesting subject of spermatzoic dimorphism.

**Development of Nervous System in Muscidæ.†**—K. Escherich gives a full account of the development of the nervous system in *Lucilia*, with especial reference to the so-called "median strand" (*Mittelstrang*). He finds in the ventral cord two genetically distinct systems:—the paired lateral nerves and unpaired median nerve. They arise independently and are only secondarily associated. As Heymons has discovered a dorsal nerve in Scolopendroids, the author suggests that the *Urform* of the nervous system in Arthropods may have consisted of four longitudinal strands.

**Species of Mosquitos concerned in Diffusion of Malaria.‡**—A. Bordi concludes from his own studies and those of others, that in the greater part of Europe malaria is diffused by *Anopheles claviger* F. (or *O. maculipennis* Mei.), and to a small extent by *A. bifurcatus* L.; that

\* Kansas Univ. Sci. Bull., i. No. 8 (1902) pp. 185-231 (4 pls.).

† Zeitschr. f. wiss. Zool., lxxi. (1902) pp. 525-49 (1 pl.).

‡ Rend. R. Accad. Lincei Roma, xi. (1902) pp. 318-24.

in Southern Europe some slight assistance is given by *A. pseudopictus* Gr. and *A. superpictus* Gr.; and that in tropical countries far and wide the diffusion is essentially due to the two species last named.

**Studies on Zoocecidia.\***—J. da Silva Tavares continues his systematic account of Portuguese Zoocecidia, extending his list from 235 to 329 species. He also † gives an account of 63 forms collected around Vienna.

**Mallophaga from Galapagos Birds.‡**—V. L. Kellogg and Shinkai I. Kuwana give a systematic account of these. They deal with 43 species, of which 25 are new. One of the interesting general facts is the unusual eccentricity of the occurrence of the parasites on the various hosts; thus one normal to a land bird occurs on a tern, and so on. We have to do with an abnormal phase of normal straggling. On the rocks of the islands maritime and land birds sit closely huddled, actual contact of the bodies often occurring. Migration is easily effected, and thus a parasite (*Colpocephalum unciferum* Keel) normally peculiar to pelicans, finds its way to a warbler or honeycreeper, *Certhidea*. On *Geospiza fuliginosa*, 20 species of Mallophaga occur,—the largest recorded list from any bird species. Four or more species are recorded from each of the 18 out of the 34 birds examined,—a condition unique in the records of collections of Mallophaga. This condition, of abundant parasitism, is, of course, due to the unusual facility of migration (or normal straggling) afforded by the forced gregarious habits of the Galapagos birds.

#### δ. Arachnida.

**Monograph on German Spiders.§**—W. Bösenberg continues his valuable monograph, dealing in the fourth part with the Dysderoidæ, Misumenoidæ, and Lycosoidæ.

#### ε. Crustacea.

**Fibrillar Continuity of Epithelial Cells and Muscles in Nebalia.||** A. Labbé finds that in *Nebalia* there is an actual continuity of substance between the epithelial “*tonofibril*” and the myofibril. The terminal delicate discs of the myofibril form a membrane in uninterrupted continuity with the basal membrane of the epithelium. Thus it comes about that the whole external epithelium has a tendinous function, the muscles being *apparently* inserted directly on the chitinous cuticle. According to Claus, the muscle-fibrils pass *between* the epithelial cells, but this is not quite accurate.

**Excretory Organs in Malacostraca.¶**—L. Bruntz has used Kowalevsky's injection-method in studying the excretion of higher Crustaceans. Cuénot found (1895) that in Decapods, in addition to the antennary kidney, an excretory function was discharged by nephrocytes in the branchial canals and by vacuolar cells in the “liver.” Bruntz has extended this conclusion to other Malacostraca, and has also found two

\* Broteria, i. (1902) pp. 1-48.

† Tom. cit., pp. 77-93.

‡ Proc. Washington Acad. Sci., iv. (1902) pp. 457-99 (4 pls.).

§ Zoologica, xiv. Heft 33<sup>iv</sup>. (1902) pp. 289-384 (9 pls.).

|| Comptes Rendus, cxxxv. (1902) pp. 750-2.

¶ Tom. cit., pp. 589-91.



new organs—the cephalic kidneys of Edriophthalmata and a pericardial organ in Amphipods.

The list is as follows:—(1) the antennary kidney and the maxillary kidney, both present in the larvæ, both persisting in *Nebalia*, the first persisting in most cases, the second in Isopods; (2) the branchial kidneys (in *Nebalia*, Amphipods, Isopods, and *Mysis*); (3) cephalic kidneys in Amphipods and Isopods; (4) the “cardiac cells,” surrounding the heart in Amphipods; and (5) the “liver” in all cases.

**Maturation-Phenomena in Oogenesis and Spermatogenesis of *Cyclops strenuus*.**\*—P. Lerat describes the first maturation-division. It falls into Flemming’s category of heterotypical division, showing a longitudinal division of the daughter-bâtonnets of the first figure in the metaphasis of the same. If there is a “reduction” in Weismann’s sense, it occurs in the first kinesis after the manner described by Montgomery.

**Absorption and Secretion in Terrestrial Isopods.**†—J. R. Murlin has made a careful study of absorption and secretion in *Porcellio scaber*, *Oniscus asellus*, and other terrestrial Isopods. The part of the intestine concerned in absorption is a single-layered epithelium of very large cells, multiplying by amitosis especially at the time of moulting. There is a mid-dorsal typhlosole. The intestinal epithelium is syncytial, the cytoplasm being continuous from one cell to another. The author describes minutely the alveolar structure of the cytoplasm, the intracellular fibres, the spherical nucleus with numerous large granules of chromatin, and the changes of the luminal side of the cells at moulting.

The changes after three weeks’ starving are described, and the subsequent results of feeding with various food-stuffs. An intracellular ferment is probably concerned in the change of food from an albumose stage to a later stage of the hydrolysis (peptone), or to a stage in the inverse process toward albumen.

The cells of the typhlosole absorb soluble foods, but the primary use of the structure is to provide channels through which the secretion of the hepatopancreas may flow, unobstructed by solid food, to the median portion of the intestine.

In the hepatopancreas there is but one kind of secreting cell, rich in zymogen granules, and forming a secretion which acts on proteids, carbohydrates, and fats. The ferment is set free by fragmentation, dissolution, or evacuation. The history of fat-foods has been very successfully followed. We have not been able to give more than a hint of the numerous detailed results of this research.

**Genus *Amphion*.**‡—E. Koepfel gives a full account of *Amphion armata* sp.n., a pelagic form captured by Chun near the Canary Islands. He brings forward evidence, e.g. the successive changes from the zoëa onwards and the occurrence of ovaries, to show that *Amphion* is a sexually mature animal and not a mere larva, like *Phyllosoma*, as has been maintained. Specifically, the form described is marked by a spine

\* Anat. Anzeig., xxi. (1902) pp. 407-11 (4 figs.).

† Proc. Acad. Nat. Sci. Philadelphia, 1902, pp. 284-359 (1 pl.).

‡ Arch. Naturges., lxxviii. (1902) pp. 262-99 (2 pls.).

on the frontal margin of the dorsal shield, by another in the gastrical region, and by a third on the third joint of the antenna. It is probably one of the Sergestidæ, and an interesting annectant form.

#### Annulata.

**Cocoons of Earthworm.\***—K. Foot and E. C. Strobell find that *Allolobophora fatida* forms cocoons apart from any copulatory process. Ten were formed by one isolated worm. Earlier observations by the authors related to cocoons formed during copulation. It is plain that there are two methods. The paper includes some notes on the spermatheca and the spermatophores.

#### Nematohelminthes.

**Intermediate Host of *Filaria immitis*.†**—T. L. Bancroft makes a preliminary communication on this large threadworm of the dog, where the adult usually inhabits the right ventricle of the heart and the pulmonary artery, while the young forms swim about in the blood in large numbers. Cobbold taught that an intermediary host is necessary to transmit the parasite from dog to dog, but efforts to find the intermediate host have not been rewarded with definite results.

Bancroft finds that the host is the "house mosquito" (*Culex skusii* Giles), which is also the host of *Filaria nocturna*, and probably also of the malarial parasite.

The sexually mature worms (*F. nocturna* in man, *F. immitis* in dog) produce embryos which swim in the blood; the mosquito is infected with these; the embryos develop first in the Malpighian tubules and then in the gut of the insect; in about three weeks they are capable of entering their final hosts if they get a chance; if the infected mosquito bite man or dog, the filariae pass in by the puncture and grow to sexual maturity, which probably takes about a year.

**Vinegar Eel in Human Bladder.‡**—C. W. Stiles and W. A. Frankland record an extraordinary case in which *Anguillula aceti* was found in the bladder of a young woman suffering from Bright's disease. The occurrence of the parasites was abundant for 34 days, and the worms thrived in the urine for a couple of months. It seems likely that infection occurred through the urethra as the result of vaginal douches with vinegar.

#### Platyhelminthes.

**Parasitic Worms as Aids in Zoogeographical Investigation.§**—H. von Ihering seeks to show that some very useful hints as to the zoogeographical distribution of mammals and birds may be obtained from a study of their helminth parasites.

Mammals and birds, during their wanderings, are not freed from their "worms," whose intermediate hosts are very widely distributed. They gain new parasites as they wander, but they retain their older guests. Thus, in South America, holartic helminths are not found in

\* Biol. Bull., iii. (1902) pp. 206-13 (3 figs.).

† Journ. R. Soc. N. S. Wales, xxxv. (1901, published 1902) pp. 41-6.

‡ Bull. U.S. Department Agriculture, No. 35, 1902, pp. 35-40 (1 pl.).

§ Zool. Anzeig., xxvi. (1902) pp. 42-51.

the autochthonous forms, but only in the heterochthonous later immigrants. Thus helminthology becomes of use in distinguishing old inhabitants from later immigrants, and on the other hand there is a possibility of distinguishing old-established parasites from more recent forms.

**New Turbellarian.\***—O. Zacharias describes *Stenostoma turgidum* sp.n., which lives along with *St. leucops* and *St. lemnae* in the bog-moss of the moor near Plön. It is milk-white in colour, 450–500  $\mu$  in length, 75  $\mu$  in maximum breadth, very like *St. lemnae*, but without its otolith-vesicles. The specific name refers to the characteristic swellings on the body.

**Notes on Gyrator hermaphroditus Ehrbg.†**—L. von Graff finds that this Rhabdocœlid resembles *Monoophorum durum*, in having two female genital apertures: one, the opening of the bursa, serves for copulation; the other, hitherto unknown, serves for oviposition. The latter, which corresponds to the female genital aperture of other digonoporous Turbellarians, is a fine pore on the ventral surface, about twice as far from the mouth as from the posterior end of the body.

**Studies on Bipalium Species.‡**—Jos. Müller has studied some new species of this genus—*Bipalium megaloccephalum*, *B. virile*, *B. graffi*, *B. bohmingi*, and *B. penzigi*, with especial reference to the copulatory apparatus.

He gives diagnoses of the new forms, and describes the reproductive organs in detail. The outstanding result is that the copulatory apparatus shows remarkable diversity of structure. It may be that this hinders inter-breeding of species.

The author also describes the pharyngeal apparatus in several species, and notes the occurrence of a Monocystid Gregarine in the gut of *Bipalium virile*.

**Trematodes from Marine Turtles.§**—A. Looss has produced an elaborate memoir of nearly 500 pages on this subject. Among the many Trematode parasites of turtles, there is one belonging to the Aspidocotyleæ, viz. *Lophotaspis adherens* Lss., one belonging to the Amphistomidæ, viz. *Amphistomum vallei*, twelve belonging to the Fasciolidæ, and fifteen belonging to the Monostomidæ, family Prononcephalidæ, and seven to the Monostomidæ, family Angiodictyidæ. In addition to the systematic descriptions, the memoir discusses questions of species and genus and type,—and other vexed questions among helminthologists.

**North American Trematodes.¶**—H. S. Pratt has published part ii. of his synopsis of North American Trematodes,—a very useful piece of work. The digenetic forms—Aspidocotylea and Malacotylea—are dealt with.

**American Representatives of Distomum variegatum.¶¶**—J. Stafford notes that, as our knowledge of faunistic helminthology widens, it

\* Zool. Anzeig., xxvi. (1902) pp. 41–2. † Tom. cit., pp. 39–41.

‡ Zeitschr. f. wiss. Zool., lxxiii. (1902) pp. 75–114 (3 pls. and 3 figs.).

§ Zool. Jahrb., xvi. (1902) pp. 411–894 (12 pls. and 2 figs.).

¶ Amer. Nat., xxxvi. (1902) pp. 887–910.

¶¶ Zool. Jahrb., xvi. (1902) pp. 895–912 (1 pl.).

becomes increasingly apparent that, in many cases, the conception of a species held by the older investigators must be broadened to include a group of closely related forms. One has but to think of such species as *Distomum appendiculatum* of fishes, and *D. cygnoides* of amphibians, to understand what confusion is likely to arise from a too rigid antipathy to an increase of specific terms. Thus, *Distomum variegatum* Rud., from the lungs of anurous amphibians, turns out to be another so-called "species" that has to be resolved into a group of "modern species."

Stafford has studied this form in many hundreds of cases; he describes their general structure, and he gives good reasons for establishing five new species under the genus *Hematolæchus* proposed by Looss.

**Production of Hydatid Cysts from Scolices.\***—Prof. Perroncito has observed that scolices of *Tenia echinococcus* may form hydatid cysts. The scolex secretes a cuticular membrane and breaks up completely, as the scattered hooklets show. His observation throws light on the serious consequences which are known to follow the opening of a cyst in the peritoneal cavity; the liberated heads settle down and form fresh hydatids.

**Life-History of Bothriotænia proboscidea.†**—G. Schneider has found the young forms of this tapeworm—a common parasite of Baltic salmon—in the stomach and intestine of the herring. But there must be some previous host through which the herring is infected, and there must be some non-marine host by which the perch, trout, and pike of the Genfer-See (quite isolated from the sea) are infected with the said tapeworm, for, as Zschokke has shown, it often occurs in them.

#### Uncertain Sedes.

**Budding of Rhabdopleura normanni.‡**—C. Vaney and A. Conte describe the regeneration of individuals and the lateral budding of the stalk in this interesting animal. In no case did their specimens show blastogenic individuals incompletely developed and giving rise to a series of buds on the stalk, as in those studied by Ray Lankester. The authors emphasise the close affinities between *Rhabdopleura* and endoproctous Bryozoa.

**Heart of Enteropneusta.§**—W. E. Ritter has independently reached conclusions similar to those of C. Dawydoff || in regard to the structure and significance of the heart in Enteropneusta. Dawydoff has stated (1) that the so-called "Herzblase" (Spengel) or "Pericardiablase" arises as a blind vesicle by abstriction from the cœlom in the dorsal portion of the proboscis; (2) that the side of the vesicle-wall turned towards the chorda invaginates into the cavity of the vesicle to form ultimately a blood-sinus, which is the real heart, the outer primary vesicle being the

\* Bull. Soc. Zool. France, xxvii. (1902) pp. 150-1 (1 fig.).

† SB. Ges. Naturfreunde Berlin, 1902, pp. 28-30. See Zool. Centralbl., ix. 902 pp. 198-9.

‡ Comptes Rendus, cxxxv. (1902) pp. 748-50.

§ Zool. Anzeig., xxvi. (1902) pp. 1-5 (3 figs.).

|| Op. cit., xxv. (1902) p. 551.

pericardium ; (3) that the relations of heart and pericardium are thus similar to those in Tunicates, especially *Appendicularia*.

Ritter has shown that the heart of *Balanoglossus occidentalis* is the ventral wall of the pericardium pocketed with the pericardial cavity, the mouth of the pocket remaining open backward and laterally, though narrowly, to form the main blood-vessels. In a word, the heart is constructed on the principle of the Tunicate heart. This type of heart is so unique, that "it is difficult enough to comprehend how it could have arisen *once*, to say nothing of its having arisen anew *twice*." There is evidence here of real affinity between Tunicata and Enteropneusta.

**Movements of Enteropneusta.\***—W. E. Ritter has made some interesting observations on the movements of *Balanoglossus occidentalis* and *Dolichoglossus pusillus*, from Puget Sound and the Californian coast.

Movements of both boring and locomotion are effected by a combination of ciliary and muscular action. The former is most in evidence when the animal creeps about on the surface of objects ; when boring, or moving up and down its canal, muscular action is most used.

When burrowing, the worm shows on its proboscis contraction-waves that move along from tip to base, but often remaining stationary in the form of great blebs. When in its burrow these blebs act chiefly as holdfasts, by which, through the contraction of the longitudinal muscles of the proboscis and collar, the whole body is drawn forward. The muscles most concerned in this are, first, those of the proboscis ; second, the radio-longitudinal muscles of the collar ; and, third, the longitudinal muscles of the "thorax-abdomen."

We have, in Enteropneusts, a system of locomotor muscles acting on an axial skeleton, derived in large part from the digestive tract. Nowhere else in Invertebrates do we find locomotion accomplished by muscles attached either to the intestinal tract or to derivatives of it. This gives an increased importance to the significance of the peculiar muscular relations of the collar region. Ecology is here, perhaps, of service to morphology.

#### Echinoderma.

**New Crinoid.†**—R. Koehler and F. A. Bather describe *Gephyrocrinus grimaldii* g. et sp. n., a new Crinoid dredged by the Prince of Monaco, at a depth of 1786 metres, near Hierre, in the Canaries. It is referred to the Hyocrinidæ, a family represented until recently by a single species, *Hyocrinus bethellianus*, dredged by the 'Challenger.' The specimen differs from *Hyocrinus*, and from all-known Crinoids, in the fact that the food-grooves are carried across from the fourth brachials to the orals on a thin unpled membrane stretching like the web of a duck's foot between each arm and the tegmen. Minor points of distinction from *Hyocrinus*, such as the fusion of the basals, the greater thickness of the cup-plates, the almost complete atrophy of the ambulacrids, and the form of the pinnules, have led the authors to give a fresh diagnosis of the Hyocrinidæ.

\* Biol. Bull., iii. (1902) pp. 255-61.

† Mém. Soc. Zool. France, xv. (1902) pp. 68-79 (4 figs.).

## Cœlentera.

Division of *Protohydra leuckarti*.\*—W. M. Aders describes, what Greeff and Chun have reported, the transverse division of this very simple hydroid polyp. Besides the longitudinal muscular elements described by Greeff and Chun, there are fine annular muscular elements.

Transverse division in *Hydra* seems to be very rare. No budding is known in *Protohydra*. Budding is usual in *Microhydra*, but no division has been seen.

Observations and Experiments on *Clava squamata*.†—A. Billard describes the degeneration and loss of tentacles in this hydroid when sexual maturity is reached. But a similar degeneration was also seen in young immature forms. Agassiz has noted a similar degeneration in sexually mature specimens of *Syncoryne*.

Billard has made a number of successful grafting experiments with *Clava*, and describes the somewhat slight regenerative capacity which this hydroid exhibits.

Minute Structure of *Syncoryne sarsii*.‡—E. Citron has made a histological study of this Tubularian, and describes minutely the covering, interstitial, stinging, ganglion, and sensory cells of the ectoderm; the nutritive, tentacular, glandular, and stinging-cells of the endoderm; the supporting lamella, and so on.

Hydroids of Pacific Coast of North America.§—H. B. Torrey makes a systematic report on these. Some of his general notes are of much interest, e.g. on the frequency of skeletal modifications due to environmental influences; and there is much pertinent oecological material throughout the paper. In connection with *Corymorpha palma*, the author describes phenomena of orientation, regeneration, &c.; in some other cases he has brief notes on the development. The keynote of the paper is that even good systematic work requires prolonged study of the living animals.

Adult Pelagic Cerianthid.||—Ch. Gravier communicates an interesting note on some adult pelagic Cerianthids captured by L. Digue in the Gulf of California. They were swimming near the surface in considerable numbers, and the reproductive elements were very nearly ripe. Young pelagic stages (*Arachnactis*, &c.) of Cerianthids are familiar, but this is the first observation of an adult pelagic form. The mesenteries were rather "biseptal" than "quatreseptal," thus differing from known Cerianthids. The larva described by E. van Beneden as *Dactylactis* seems nearest the new form.

Actiniaria of the Olga Expedition.¶—O. Carlgren reports on an Arctic collection of eight species previously described. With one ex-

\* Zool. Anzeig., xxvi. (1902) pp. 33-9 (11 figs.).

† Bull. Mus. Hist. Nat. Paris, 1902, pp. 345-9.

‡ Arch. Naturges., lxxviii. (1902) pp. 1-26 (2 pls.).

§ Publications Univ. California (Zoology), i. (1902) pp. 1-104 (11 pls.).

|| Comptes Rendus, cxxxv. (1902) pp. 591-3.

¶ Zool. Ergebn. einer Untersuchungsfahrt des Deutsch. Seefischerei Vereins nach der Bäreninsel u. Westspitzbergen, ii. Teil. (1902) pp. 31-56 (1 pl. and 10 figs.).

ception, all are large forms, notably the gigantic *Bolocera multicornis* with several thousand tentacles. Three different species were found in the stomach of a cod, which shows that this fish does not disdain sea-anemones. Carlgren has used the excellently preserved specimens to good purpose in the way of histological study.

**Significance of Budding and Fission in Madreporaria.\***—J. E. Duerden notes that the bud-polyps of gemmiferous corals arise as new individuals, which, in the course of their development, pass through the same stages as larval polyps, and ultimately possess all the distinctive characteristics—cyclical, hexamerous plan, and directive mesenteries—of sexually produced polyps.

Larval polyps of fissiparous corals at first present a regular, cyclical, hexamerous arrangement of the mesenteries, tentacles, and septa.

“Morphologically, a fissiparous coral, whatever its size, is to be regarded as only a single complex polyp, as contrasted with a gemmiferous colony, which is made up of numerous distinct individual polyps.”

**Notes on Anemones and Variation in Metridium.†**—H. B. Torrey gives a systematic account of the anemones collected by the Harriman Alaska Expedition (six genera and six species). One genus, *Charisea*, and two species, *Charisea saxicola* and *Epiactis ritteri*, are described as new. The memoir also includes a description of a new Halcampid, *Harenactis attenuata*, from California, a few facts concerning *Epiactis prolifera* Verrill, and a discussion of the variations in *Metridium dianthus*.

In reference to the last topic, it may be noted that the author seeks to show:—(a) that regular hexamerous diglyphic polyps arise non-sexually as well as sexually; (b) that monoglyphic forms arise sexually as well as non-sexually; (c) that irregularities in the number and arrangement of mesenteries may be accounted for largely, perhaps exclusively, by non-sexual reproduction (mainly basal fragmentation); and (d) that variation of structural types is not correlated with mode of reproduction, but that the cause of such variation must be sought among the causes of variation in the number of siphonoglyphs, of the correlation of siphonoglyphs and directives, and the like. What these causes are is at present unknown.

#### Protozoa.

**Reproduction of Acanthometridæ.‡**—A. Porta describes two modes of multiplication:—(a) by spores; and, rarely (b) by budding. Corresponding thereto are two kinds of juvenile forms:—(a) uninuclear individuals of considerable size, with well-developed skeleton; and (b) multinuclear individuals of small size, in which the skeleton is absent, or very slightly developed.

In *Acanthometra cuspidata* Hkl. the author found a peculiar parasite—*Amæbophrya acanthometræ*—as yet *incertæ sedis*.

**New Tripylea.§**—A. Borgert describes, from the material of the German Plankton Expedition, some interesting new Radiolarians, be-

\* Ann. Nat. Hist., lix. (1902) pp. 382-93 (4 figs.).

† Proc. Washington Acad. Sci., iv. (1902) pp. 373-410 (2 pls. and 17 figs.).

‡ Rend. R. Ist. Lombardo. xxxiv. (1901) pp. 811-22 (2 pls.).

§ Zool. Jahrb., xv. (1902) pp. 563-77 (11 figs.).

longing to the families Medusettidæ (e.g. *Medusetta inflata*, *Euphysetta rara*); Circoporidæ (e.g. *Circoporus oxyacanthus*, *Circogonia* (?) *longispina*); and Tuscaroridæ (e.g. *Tuscarusa globosa*).

**Lambliæ intestinalis Fatal to Rabbits.\***—Prof. Perroncito finds that this Flagellate (with many synonyms,—*Cercomonas intestinalis*, *Megastoma intestinale*, &c.), common in man and in the rat, as a parasite on the epithelial cells of the duodenum and elsewhere, causing obstinate constipation followed by profuse diarrhœa, is a frequently fatal parasite of rabbits, resulting in a mortality whose cause was previously unknown.

**New Species of Chilodon.†**—Th. Moroff describes *Chilodon cyprini* sp. n., which lives on the skin and gills of diseased carp, though it is not itself the cause of the disease. It seems nearly allied to *Ch. megalotrochæ* Stokes, parasitic on certain Rotifers.

**Parasites of an Asiatic Tortoise.‡**—A. Laveran and F. Mesnil found in *Damonia reevesii*, two Hæmogregarines (*Hæmogregarina stephanowiana* sp. n. and *H. rara* sp. n.), *Trypanosoma damoniae* sp. n. in the blood, *Coccidium mitrarium* sp. n. in the gut—a form remarkable in having an *extra-cellular* life, and the Myxosporidian *Myxidium danilewskyi* in the kidneys, where it also occurs in *Emys lutaria*.

**Trypanosomas from Transvaal Cattle.§**—A. Laveran gives a fuller account of *Trypanosoma theileri*, a parasite discovered by Theiler, a veterinarian at Pretoria, as has been previously noticed. The parasite is widespread in South Africa, causing Galziëkté or bile-disease in cattle. Theiler has also sent to Laveran preparations of ox-blood, which reveal another species, *Tr. transvaaliense* sp. n. It seems quite distinct, e.g. in the close proximity of the centrosome to the nucleus. It remains to be seen whether it is restricted to Bovidæ as the other species is.

**Hæmatozoa in Marine Fishes.||**—A. Laveran and F. Mesnil have shown that some marine fishes are often infected with Hæmatozoa. They note the occurrence of *Trypanosoma rajæ* sp. n. in three species of skate; of *Tr. scylliumi* sp. n. in *Scyllium stellare*; of *Hæmogregarina delagei* sp. n. in two species of skate. A large number of bony fishes were examined, but Hæmogregarines were found only in the sole and in blennies, and *Trypanosoma* only in the sole, and that very rarely.

\* Bull. Soc. Zool. France, xxvii. (1902) pp. 151-5 (1 fig.).

† Zool. Anzeig., xxxvi. (1902) pp. 5-8 (3 figs.).

‡ Comptes Rendus, cxxxv. (1902) pp. 609-14 (13 figs.).

§ Tom. cit., pp. 717-21 (5 figs.).

|| Tom. cit., pp. 567-70.





## BOTANY.

## GENERAL,

Including the Anatomy and Physiology of Seed Plants.

## Cytology,

including Cell-Contents.

**Nuclei of Unicellular Animals contrasted with those of Plant Cells.\***—L. Feinberg shows that the nuclei of organisms such as *Amæba*, *Plasmodiophora*, the malarial parasite, &c. exhibit a structure quite different from that of the nuclei of ordinary animal and plant cells. While the latter nearly always show a chromatin network, which with the Romanowski stain becomes coloured red, and nucleoli which, like the protoplasm, becomes coloured blue with the same stain; the former show merely a number of nucleoli, which, by the Romanowski method, stain red, not blue, and are surrounded, not by a chromatin network, but by a clear area which remains unstained and seems to represent cell and sap. Feinberg concludes that, from their staining reaction, the nucleoli of these animal-like unicellular organisms are comparable to the staining network of ordinary animal and plant cells.

**Continuity of Protoplasm.†**—H. Kraemer suggests that the appearances described by Gardiner and others as indicating a continuity of protoplasm through the cell-wall, are due to a peculiarity in the structure of the cell-wall, which is made manifest by the reagents employed, and which bears an analogy to the structure of the starch-grain. He cites observations which lead to the following interpretations. The starch-grain and the cell-wall are made up of alternating lamellæ of colloidal and crystalloidal substances. Physically the structure of the starch-grain and cell-wall are quite similar, although chemically different, the preponderating substance in the grain being granulose, while in the cell-wall the fundamental substance is cellulose. The crystalloidal layer in the starch-grain, consisting chiefly of granulose, is coloured blue with iodine or chlor-zinc iodide, whereas in the cell-wall this layer, consisting chiefly of cellulose, is coloured blue only with chlor-zinc iodide. The colloidal layers in both grain and cell-wall take up various anilin dyes. In starch-grains, as in cell-walls, there are radial clefts or colloidal areas, which, under certain conditions, also take up various anilin stains. The peculiar biconvex arrangement of the groups of striæ between contiguous cells in *Nux vomica* and *Phytelephas* is suggestive of fundamental lines of development corresponding to chromatin threads, although they may be modifications of the wall and represent tracts or channels through which liquids are distributed from cell to cell. All authors since the appearance of Gardiner's work have fallen into the error of supposing that a certain anilin dye could be regarded as a differential stain for protoplasm, whereas many colloidal

\* Ber. Deutsch. Bot. Ges., xx. (1902) pp. 281-3.

† Proc. Amer. Philosoph. Soc., xli. (1902) pp. 174-80 (2 pls.).

carbohydrates, as mucilage and pectin, and oils and other substances, take up these stains. Finally, if the substance in the cell-wall which takes up the stain is protoplasm, what is it in the starch-grain?

**Nuclear Reduction and Fertilisation in Paris and Trillium.\***—A. Ernst has investigated the chromosome reduction, embryo-sac development, and fertilisation in *Paris quadrifolia* and *Trillium grandiflorum*. In *Paris* the reduction in the number of chromosomes is from 24 to 12, and this takes place at the first division of the embryo-sac mother-cell. This division is of the characteristic heterotype, and results in the production of two cells, the lower of which becomes directly the embryo-sac, while the upper, after a second division of its nucleus, degenerates. In *Trillium* the reduction is from 12 to 6 chromosomes (the smallest number known in the vegetable kingdom, and found also in *Najas*), and of the two cells formed the upper usually degenerates without division, while the lower becomes directly the embryo-sac. The heterotypic division was studied, and the synapsis stage, which the author believes to be a natural condition, was observed. The chromosomes of this division in both plants often show, in the equatorial flake stage, indications of a second longitudinal division. In the diaster stage, by separation of the two halves of the daughter-chromosomes, produced by this second division, V-, U-, and O-shaped figures are often produced. When the daughter-nuclei are reconstituted, this second division becomes lost, but a fresh longitudinal splitting of the chromosomes is to be observed when the nuclei divide again. All the divisions in the embryo-sac were found to be exactly similar, so that, in contrast to *Lilium*, *Fritillaria*, and *Tulipa*, the normal reduced number of chromosomes is found even in antipodal nuclei. Double fertilisation was observed in both cases, but actual fusion of the three nuclei appears to take place only on the spindle, for in all three the beginning of a definite chromatin thread was observed while they were in contact but yet unfused. The facts that in the vegetative cells of *Trillium* 8 chromosomes, instead of the normal 12, were sometimes to be observed, and that the number of chromosomes in *Paris* is exactly double that of *Trillium*, when compared with the variations in number among the genera of the Liliaceæ, suggest that the chromatin thread of the nucleus undergoes a successive, and not a simultaneous division.

**Nucleus of Spirogyra.†**—C. van Wesselingh has added yet a fourth to his papers on the nucleus of this alga. In this contribution he pays special attention to the question of the nuclear wall and spindle, and the behaviour of the vacuole-wall during karyokinesis. By slowly killing dividing cells, and by the use of 20 p.c. chromic acid solution, combined with staining, he was able to prove that the spindle consists of a number of similar threads, which surround the nucleus and are combined together to form numerous bundles. The spindle-threads do not grow through the nuclear wall, but the latter disappears at an early stage, and the spindle is at first multipolar, but later becomes bipolar. The observations were made on *Spirogyra informis*.

\* Flora, Ergänzungsband, 1902, 46 pp. (6 pls.).

† Bot. Zeit., lx. (1902) pp. 115-38 (1 pl.).

**Observations on the Nucleolus.\***—F. Cavara has made observations on the nucleolus of the embryo-sac of *Lilium candidum* which lead him to believe that during division the nucleolus extrudes a small corpuscle by a process of gemination. This corpuscle, he believes, is derived from the central and more slightly staining part, and is probably used for the formation of the spindle. The much more deeply staining peripheral portion of the nucleolus, he suggests, is placed at the disposal of the chromosomes.

**Glycogen from Yeast.†**—A. Harden and W. J. Young have studied the glycogen prepared by extracting yeast. They find its chemical composition to be represented by the formula  $C_6H_{10}O_5$ , thus showing its identity in composition with glycogen prepared from animal sources. The optical activity is also the same, and from a consideration of the various properties of glycogen from yeast, and from animal sources, it appears that no well-marked difference exists between the two.

**New Proteid from Maize.‡**—E. Donard and H. Labbé describe a new proteid, maïsine, which they have extracted from seeds of maize. Its analysis corresponds to a chemical composition  $C_{184}H_{300}N_{46}O_{51}S$ . It is insoluble in cold or hot water, and in the various salt solutions, soluble in methyl and ethyl alcohol, insoluble in aqueous acetic acid, but soluble in aqueous solutions of soda or potash, even when very dilute.

**Reserve Carbohydrates of the Albumen of Palms.§**—E. Liénard has studied chemically the carbohydrates contained in the seeds of *Areca Catechu*, *Chamierops excelsa*, *Astrocaryum vulgare*, *Cenocarpus Bacaba*, *Erythea edulis*, and *Sagus Rumphii*. He finds in each case a small amount of saccharose, and also, as a result of fractional hydrolysis, mannose and, in less quantity, galactose.

**Detection of Phosphorus in Plants.||**—A. Arcangeli discusses the value of the microchemical reagents that have been proposed for the detection of phosphorus in plant tissues, for example the employment of ammonium molybdate and nitric acid, and, in order to render the result more evident, the subsequent addition of either pyrogallic acid or stannous chloride, which yield respectively a brown and a blue coloration. He has made numerous experiments, and has come to the conclusion that as yet no satisfactory microchemical method has been established for the purpose, for the phosphomolybdate reaction does not always take place; the tissues respond to the reagent with different degrees of density (independently of the quantity of phosphorus they contain); the molybdic reagent is capable of giving the blue coloration with stannous chloride independently of the presence of phosphorus, and is liable to be influenced by the presence of other substances.

**Caoutchouc-yielding Landolphia of the French Congo.¶**—Aug. Chevalier gives short botanical descriptions of three species of herba-

\* Bull. Soc. Bot. Ital. (1902) pp. 108-12 (5 figs.).

† Journ. Chem. Soc., lxxxi. (1902) pp. 1224-33.

‡ Comptes Rendus, cxxxv. (1902) pp. 744-6. § Tom. cit., pp. 593-5.

|| Atti Soc. Toscana Sci. Nat., xviii. (1902) pp. 214-32.

¶ Comptes Rendus, cxxxv. (1902) pp. 512-5.

ceous lianes belonging to the tribe Landolphiææ. The most widespread — *Carpodinus lanceolatus*—does not yield caoutchouc. The species which yields most of the product is *Landolphia Tholloni*; the aërial shoots contain no caoutchouc in their latex, but the cortex of the long rhizomes is rich in an excellent product. A third species, hitherto undescribed, is *L. humilis*, in which the caoutchouc is confined to the subterranean rhizomes; it contains less of the product than does *L. Tholloni*.

**Leaf-Venation and Chemical Constituents of Eucalypts.\***—R. T. Baker and H. G. Smith find that there is a marked agreement between the chemical constituents in the oils and the venation of the mature lanceolate leaves of the several species of New South Wales Eucalypts, thus forming the genus into fairly well-marked groups. There is reason to suppose that a gradual deviation from a type has taken place, and that the formation of characteristic constituents in these oils has been contemporaneous with the characteristic alteration or deviation of the venation of their leaves.

**Gums, Resins, and other Vegetable Exudations of Australia.†**—J. H. Maiden gives a list of the genera and species yielding gums, &c., arranged in families, with notes on the plants and their exudations. It is followed by "a tentative bibliography of Australian vegetable exudations."

### Structure and Development.

#### Vegetative.

**Conifer Wood from the Turf-Pits.‡**—L. Géneau de Lamarlière has investigated the structure of semi-fossilised woods from turf-pits in the marshes of Saint Gond, now for the most part dry. He concludes, from examination of their remains, that during the tertiary period, conifers which reached a great height existed in Champagne, thus confirming the statements of previous writers. The wood shows a recognisable microscopic structure, though profoundly modified structurally, physically, and chemically. From the morphological point of view, he describes a network of intercellular lamellæ, modified only by the amount of compression to which the trunk has been subjected, cells which apparently have undergone no change (refrangent cells), and others where the internal thickening layers have disappeared or been transformed into an amorphous annular or continuous mass. From the chemical point of view, the changes are very marked. The intercellular network still gives the reactions of pectic compounds, but it is probable that pectic acid occurs in the free state and not in combination with lime as appears to be the case in plants in the normal condition. In addition, lignin occurs and perhaps also phosphates.

The refrangent cells seem to be elements which have not been attacked by destructive agents. Their walls still contain cellulose, pectic compounds, lignin, and phosphates. The amorphous substance

\* Journ. and Proc. Roy. Soc. New South Wales, xxxv. (1902) pp. 116-23 (1 pl.).

† Tom. cit., pp. 161-212.

‡ Rev. Gén. Bot., xiv. (1902) pp. 241-53, 300-15 (15 figs. in text).

shows sometimes traces of cellulose and pectic compounds. The greater part consists of the substance described by Frémy as vasculose.

**Comparative Anatomy of the Stem in Magnoliaceæ.\***—G. D'Ippolito describes the structure of the transverse section of the stem in the chief genera of the order, especially with relation to that of the secondary wood.

**Parasitism of Buckleya Quadriala.†**—S. Kusano has made an elaborate study of the parasitism of this member of the family *Santalaceæ*. The fact of its parasitic habit was discovered by Shirai, and announced in his work on plant diseases (published in Japanese in 1894). Kusano finds that a number of species may serve as hosts, including the conifers *Cryptomeria*, *Abies firma*, *Chamaecyparis*, and species of *Quercus*, *Carpinus*, *Fagus*, *Alnus*, *Rhododendron*, and others. A full description is given of the form and anatomy of the haustoria and of the secondary growth in thickness. The haustorium has a cambium ring between its cortical and axial parts, whereby a continued growth in thickness is effected. The cambium of the haustorium joins that of both the host and the mother root. Demarcations between the zones produced in each growth-period are visible, though faintly.

**Anatomy of Anonaceæ.‡**—H. Beyer gives a general account of the anatomy of the vegetative and floral organs, especially of African species of this family; also a short anatomical description of the leaves of all the African species studied.

**Protection of Young Foliage Leaves and Seed Leaves.§**—A. Hansgirg has studied the means of protection against injury, excessive loss of water, &c. in the young leaves and cotyledons of a large number of plants, including ferns and seed plants. In this connection he arranges under twelve biological types, the young foliage leaves developing from subterranean and aerial buds.

**Localised Stages of Growth.||**—J. A. Cushman has studied the early spring growth in some common New England plants with a view to the appearance of stages of development, similar to stages found in the young individual and also in the adult of ancestral forms. He notes a well marked relation between the occurrence of the earliest stages and the age of the plant. The plant coming up in its second year tends to be more primitive in its first characters than older and stronger plants, and therefore repeats more stages in arriving at the typical form than do older individuals. Weak individuals are more apt to show earlier stages than are more vigorous plants; this is true whether the whole is weak or whether the growth arises from adventitious or weaker buds.

**Thorns of Gleditschia triacanthos.¶**—J. A. Harris figures and describes some variations from the usual structure noted during one season in the thorns of this species.

\* *Malpighia*, xv. (1902) pp. 438-60.

† *Journ. Coll. Sci. Imp. Univ. Tokyo, Japan*, xvii. (1902) Art. 10, 42 pp. (1 pl.).

‡ *Engl. Bot. Jahrb.*, xxxi. (1902) pp. 516-55 (figs. in text).

§ *Beih. Bot. Centralbl.*, xiii. (1902) pp. 173-93.

|| *Amer. Natural.*, xxxvi. (1902) pp. 865-85 (5 pls.).

¶ *Trans. Acad. Sci. St. Louis*, xi. (1901) pp. 215-22 (5 pls.).

**Distribution of Hairs on the Surface of the Stem.\***—A. Daguillon concludes as the result of an examination of the distribution of hairs on the stems of various herbaceous plants, including species of *Veronica*, *Stellaria*, and other members of the order Caryophyllaceæ, that in some herbaceous plants there exists a relation between the distribution of hairs on a stem and its branching, the hairs being usually restricted to, or more abundant at the portion above the axillary buds.

**Manual of Indian Timbers.†**—J. S. Gamble has prepared a new and revised edition of this work, which contains a short diagnosis of the wood and bark characters of all the woody plants of British India, with notes on the distribution of the species, their cultivation, and economic use. The arrangement is a systematic one and follows that of Hooker's *Flora of British India*. The plates represent cross sections of nearly one hundred species.

#### Reproductive.

**Lagochilus.‡**—R. Wagner discusses the morphological details of the inflorescence in species of this eastern genus of Labiatae.

**Cause of Floral Zygomorphism.§**—L. Barsanti reviews the opinions of Sprengel, De Candolle, Monquin-Tandon, Roeper, Dutrochet, Vöchting, Delpino, and others, on the cause of asymmetry in flowers, and expresses his own conclusions, which are that flowers were actinomorphic at first; that by evolution some have become zygomorphic; that such zygomorphism was caused by mechanical causes such as pressure, or by conditions of light or gravity, or by a biological cause such as the visits of fertilising insects; that it gradually acquired stability and became transmitted by heredity.

**Theory of the Petiole in the Flower.||**—D. Clos returns to the discussion of the morphology of the stamen, a subject which he has treated in previous memoirs. He holds the view that in most cases the filament of the stamen represents, in dichlamydeous flowers, the median nerve of the sessile petal or the claw of the clawed petal; and that the anther is a distinct structure of special nature. He criticises adversely the view adopted by many botanists that the filament is homologous with the stalk, and the anther with the blade of a leaf. He points out that there is no relation between the existence of filaments in the androecium and of petioles in the leaves of the same species. Thus sessile leaves and long filaments occur in numerous Caryophyllaceæ, Cruciferae, Crassulaceæ, and other families, while *Aristolochia*, *Arum*, and *Dracunculus* supply examples of sessile anthers and long-petioled leaves.

On the other hand, there is a striking resemblance between the petals and the filaments in many species of different families both

\* Rev. Gén. de Bot., xiv. (1902) pp 289-99 (5 figs. in text).

† J. S. Gamble, 'A Manual of Indian Timbers: an account of the growth, distribution, and uses of the trees and shrubs of India and Ceylon, with descriptions of their wood structure.' New and revised edition, London, Sampson Low & Co., xxvi. and 856 pp. and 20 pls.

‡ Verhandl. k. k. Zool.-bot. Gesell. Wien, lii. (1902) pp. 540-62 (11 figs. in text).

§ Atti d. Soc. Toscana di Sci. Nat., xviii. (1902) pp. 126-41.

|| Mém. Acad. Sci. Toulouse, ser. 10, i. (1901) p. 105-18.

monocotyledons and dicotyledons, while in Nymphaeaceæ and others there is a gradual transition from petals to filaments by narrowing of the former. Again, the petal and the filament have essentially the same anatomical organisation, while that of the petiole is quite different. The connective is merely the continuation of the filament, and it is the connective, and not the anther-cells, which frequently become petaloid. The anther-cell, like the ovule, is a structure *sui generis*. In very rare instances sepals, petals, or carpels are supported on a true petiole quite distinct from the blade in the first two cases.

**Development of Pollen in Asclepiads.\***—Paul Dop has studied the development of pollen in species of *Asclepias*, *Vincetoxicum*, *Gomphocarpus*, *Marsdenia*, and other genera, and finds throughout results comparable to those obtained by Chauveaud in *Vincetoxicum officinale*. The pollen-mother-cells arise by division of subepidermal cells, and give rise to the pollen-grains directly by division into four. The nutritive layer formed of one or several layers of cells, secretes the waxy envelope around the pollinium, while the candicles and retinacula are secreted by the epidermal cells of the stigma. After the dehiscence of the pollen-sac, the pollinium escapes from the sac and attaches itself to the candicles.

**Germination of Pollen-Grains.†**—P. P. Richer finds that the pollen of certain species which will not germinate in pure water, will germinate if a stigma of the same species or an allied species be placed in the water. On the other hand, it germinates less successfully, or may even fail to germinate, in the presence of a stigma of a very different plant. He concludes that there exist in the stigma special substances which encourage the germination of the pollen of the same plant, while inhibiting the germination of the pollen of a strange plant.

**Double Fertilisation in Crucifers.‡**—L. Guignard has been able to follow all stages of this phenomenon in *Capsella Bursa-pastoris* and *Lepidium sativum*. The sexual apparatus has the normal structure and arrangement; the two polar nuclei fuse only a short time before fertilisation, and the large secondary nucleus lies close to the oosphere. The double fertilisation follows the usual course. The male nuclei reach almost simultaneously the nucleus of the oosphere, and the secondary nucleus of the embryo-sac, but the process of fusion is completed earlier in the case of the latter, and the division of the resulting cell precedes that of the egg. In the course of development of the embryo the albumen gradually disappears, with the exception of the peripheral layer. This, which the author has previously styled the proteid layer, persists in the ripe grain in all Crucifers, as it does also in almost all families the seed of which is described as exalbuminous.

#### Recent Investigations in the Embryo-sac of Angiosperms. —

D. H. Campbell gives a *résumé* of recent work on the course of events in the embryo-sac of Angiosperms. He regards *Peperomia* as the most primitive form yet described, basing his conclusions on the absence of a

\* Comptes Rendus, cxxxv. (1902) pp. 710-2.

† Tom. cit., pp. 634-6.

‡ Tom. cit., pp. 497-9.

§ Amer. Natural., xxxvi. (1902) pp. 777-86 (5 figs. in text).

definite egg-apparatus and antipodals, and especially the increase in the number of nuclei. There is a striking similarity between the structure of the embryo-sac in *Peperomia* and in *Gnetum* among Gymnosperms. The typical embryo-sac may have been derived from one like *Peperomia* by the suppression of a nuclear division. The marked polarity, and the specialisation of the egg-apparatus and antipodal cells, are probably secondary characters, and the fusion of the polar nuclei finds its prototype in the multiple fusion of the nuclei in *Peperomia* to form the endosperm-nucleus. The egg-cell probably represents an archegonium reduced to a single cell, and the synergidæ may also represent potential archegonia, although they may with equal probability have been derived from vegetative prothallial cells. The remaining structures—the polar nuclei (and the result of their fusion, the endosperm-nucleus) and the antipodal cells represent vegetative prothallial tissue. The fusion of the polar nuclei is in no way to be regarded as a sexual process; the regular occurrence of a multiple fusion in *Peperomia* is a strong argument against such an assumption. It is probably to be interpreted as a stimulus to further growth. The fusion of the second pollen-nucleus with the endosperm-nucleus must be considered as more or less accidental.

### Physiology.

#### Nutrition and Growth.

**Physical Conditions of Tuberisation in Plants.\***—Noel Bernard discusses the bearing of results recently obtained by M. Laurent on his own theory that the development of buds into tubercles is a symptom of a general modification of the internal constitution of a plant by the action of endophytic fungi which inhabit its organs of absorption. M. Bernard repeats the experiments of M. Laurent, and confirms the results arrived at by that author. Shoots of potatoes cut off and plunged into a solution of saccharose, glycese, glycerin, and other solutions of sufficient concentration, develop tubercles from the buds on their aerial stems. He concludes that the result is due, not to the specific properties of the dissolved substance, but to the degree of concentration of the solution. In every case there is a critical concentration of the solution below which the buds develop into leafy branches, while if it be exceeded tubercles are formed. It would appear that the tuberisation of the buds depends directly on the realisation of a certain degree of concentration of the sap which nourishes them in dissolved substances. The presence in the tissues of the plant of parasites capable of effecting by their diastatic secretions an increase in the complexity of the molecular compounds is one of the conditions which may lead to this state. Other factors, especially those which govern transpiration, may have the same effect. Hence M. Laurent's results are not inimical to the author's parasite theory of tuberisation.

**Photosynthesis.†**—E. Griffin has investigated the relative amount of photosynthetic action in green leaves when the upper and under surfaces respectively are illuminated. He wished to test the hypothesis

\* Comptes Rendus, cxxxv. (1902) pp. 706-8.

† Tom. cit., pp. 303-5.



of Stahl and Haberlandt, who have explained differentiation of the mesophyll of an ordinary dorsiventral leaf into an upper palisade and a lower spongy layer as an adaptation to favour photosynthesis, and at the same time to ensure the protection of the chlorophyll-corpuscles. The author finds that with dorsiventral leaves photosynthesis is reduced if the lower surface is illuminated by direct sunlight instead of the upper. The greatest difference is found in thick leaves; e.g. in cherry laurel the proportion was as 100 to 48. In leaves where the mesophyll is more or less homogeneous, as in the bamboo, the difference was small, the proportion being 100 to 92.

R. O. Herzog \* finds that extracts prepared from crushed green leaves by the method used by Buchner to extract the ferment from yeast have no power to absorb carbon dioxide and give out oxygen. This confirms the view that the photosynthetic power of the chlorophyll corpuscle is dependent on the life of the protoplasm.

**Assimilation of Yeasts.**† — Th. Bokorny, of Munich, has studied the effect of the environment on the life of the yeast plant. He made a series of experiments on the influence of temperature, and he found that while 35° C. was too warm, 5° C. was too cold for healthy development. At the lower temperature the weight of the plant decreased. This result coincides in some measure with that determined by Krensler for green plants; 20° was found to be more favourable than 35°. Cold did not, however, affect so seriously the green plant experimented with. The writer tested also the effect of various concentrations of fluid, to some of which poisons or otherwise harmful substances were added. In most of the experiments a 20 p.c. solution of cane-sugar was used, but the highest degree of activity was reached with 5 p.c. The greatest retardation resulted from the introduction of minute quantities of caffeine. Fluoric acid was found to be almost equally hurtful. Free phosphoric acid was also found to act as a check.

#### Irritability.

**Influence of Light on Seed-Germination.**‡ — E. Heinricher has studied the relation of light to the germination of seeds in a number of genera and species. In the case of many plants which inhabit strongly insulated localities light seems to exercise a very important influence on germination; but the rule is not general, as certain light-loving plants, such as species of *Mesembryanthemum* and others, germinate as rapidly and as well in the dark as in the light, and in some cases, as in the Bromeliad *Acanthostachys strobilacea*, darkness favours germination. Seeds of *Pitcairnia maidifolia* and *Drosera capensis*, on the other hand, refused to germinate in complete absence of light; such a strongly-marked influence of light has been known previously only in the case of the mistletoe. The author suggests that the same relation holds in the case of other plants, especially light-loving epiphytes of the savannas: most of the *Tillandsiæ* probably resemble *Pitcairnia maidifolia* in this

\* Zeit. Physiol. Chem., xxxv. (1902) pp. 459-64. See also Journ. Chem. Soc. lxxxiii. (1902) ii. p. 578.

† Centralbl. Bakt., ix. (1902) pp. 55-62.

‡ Beih. Bot. Centralbl., xiii. (1902) pp. 164-72.

respect. Seeds of the latter plant were found to require a longer light exposure if the other conditions of germination (dampness and warmth) had been previously present. In the case of *Drosera capensis*, if illumination was too long delayed in presence of otherwise favourable conditions, power of germination was lost. In other cases presence of light exercised only an accelerating effect. Remarkable differences were noted in plants of the same family or even genus.

**Relations of Plant-Growth to Ionisation.\***—A. B. Plowman is conducting a series of experiments at the Harvard Botanic Garden on the relation of plants to electricity. He finds that seeds placed near the anode are always killed by a current amounting to 0.003 ampere or more if continued as long as twenty hours, while seeds placed near the cathode are generally but little affected, though sometimes they are apparently stimulated by the current. He suggests that these effects are produced by the electrical charges of the ions rather than by any mere chemical activity of the dissociated atoms, and concludes that negative charges stimulate, and positive charges paralyse, the embryonic protoplasm of the plants. In support of the latter statement he adduces the fact that when a flower-pot containing lupins of about four weeks' growth is charged to relatively high potential with positive electricity, the plants stop growing, gradually lose turgidity, and finally die. On the other hand, when a negative charge is used, these effects are not produced, but the plants are actually stimulated.

#### Chemical Changes.

**Enzyme in Ripening Plantains.†**—C. R. Newton discusses the relation between enzyme action and disappearance of tannin in ripening plantains. The unripe fruit contains large quantities of tannin, while in the dead-ripe fruit scarcely any trace is left. Tincture of guaiacum turns blue the cut surface of the unripe fruit, and the action is most intense in the neighbourhood of the cells which give the strongest tannin reaction with solution of iron salts, namely, those between the skin and the pulp and those near the seeds. Judged by the colour test plantains contain a variable quantity of enzyme. Those grown in the plains had the most, those in the hills, which require to be hung for a long time, often months, to ripen, have a much less quantity, and the wild ones, that never lose their very astringent taste, the least of all. This suggests that the action of an enzyme on the tannin is one of the principal factors in the ripening of the fruit.

**Yeast Ferment.‡**—Th. Bokorny, of Munich, gives us the results of his research on the proteolytic enzymes of yeast. He discusses the quantities produced, and then compares the results with those produced by pepsin and trypsin. The author attacks several other problems: the distinguishing of the different proteolytic effects produced in the yeast; the most favourable conditions of acidity; and the influence of nutrition on the production of enzymes.

\* Amer. Journ. Sci., ser. 4, xiv. (1902) pp. 129-32.

† Indian Garden and Planter, April 24, 1902.

‡ Beih. z. Bot. Centralbl., xiii. (1902) pp. 235-64.

## General.

**Notes on *Styracæ*.**\*—Janet Perkins gives descriptions of some new species of *Styrax* from tropical America, and a list of all known tropical Asiatic species of the genus arranged in clavis form. A few new species are described from China and Sumatra.

**Revision of the Species of *Lisianthus*.**†—The same author contributes a systematic revision of the fifteen species of this West Indian and Central American genus of *Gentianacæ*.

**Monograph of the *Myricacæ*.**‡—Aug. Chevalier gives an exhaustive monograph of this family, including a brief historical introduction, a general detailed account of the anatomy, histology, and organography of its members, and a systematic revision of the species, including full descriptions and notes on geographical distribution. He restores to generic rank *Gale*, which includes the common species *Myrica Gale* L., and *Comptonia*, which comprises the Canadian *Myrica asplenifolia* L.

**Floral Distribution in the Alpine Zone.**§—P. Jaccard discusses the factors which determine the plant distribution in alpine zones, and formulates a number of laws by which it is governed.

**Plant-Formations and Flora of South Bulgaria.**||—J. Podpera describes the topographic and climatic condition of the country and the various plant-formations. He then begins an enumeration of the plants, among which are included several new species, varieties, and forms.

**Chinese Flora.**¶—The continuation of Forbes' and Hemsley's Enumeration of Plants from China and adjoining Islands, part xiii., contains the *Gymnosperms*. Dr. Masters has elaborated the *Conifers* and Sir W. T. Thiselton-Dyer the *Cycads*. This portion completes a volume (*Stylidiæ* to *Cycadacæ*) and is an index number.

**Flora of Uruguay.**\*\*—J. Arechavaleta supplies notes on various species of seed-plants and descriptions of new species of *Ionidium*, *Monnina*, *Cordia*, *Hypericum*, and *Eriocaulon*.

**Monograph of North and Central American Species of *Senecio*.**††—J. M. Greenman gives the first part of his monograph. It comprises a general account of the morphology of the genus, a review of the systematic grouping of the species in sections and subgenera, a nominal enumeration of the species in their respective sections, and an account of their geographical distribution. The second part, which is to follow, will contain the special systematic portion.

**Notes on Australian Botany.**—R. H. Cambage †† continues his notes on the botany of a portion of the interior of New South Wales, the present instalment forming part vi.

\* Engl. Bot. Jahrb., xxxi. (1902) pp. 478-88. † Tom. cit., pp. 489-94.

‡ Mém. Soc. Natur. des Sci. Nat. et Math. Cherbourg, xxxii. (1902) pp. 85-340 (8 pls. and 1 map).

§ Bull. Soc. Vaudoise Sci. Nat., ser. 4, xxxviii. (1902) pp. 69-130 (5 pls.).

|| Verhandl. k. k. Zool.-bot. Ges. Wien, lii. (1902) pp. 608-64.

¶ Journ. Linn. Soc., xxvi. (1902) pp. 537-92.

\*\* Anal. Museo Nacion. Montevideo, iv. (1902) pp. 1-24 (5 pls. and 3 figs. in text).

†† Engl. Bot. Jahrb., xxxii. (1902) pp. 1-33.

‡‡ Proc. Linn. Soc. New South Wales, xxvii. (1902) pp. 186-204 (3 pls.).

E. Cheel \* insists on the specific identity of *Juncus holoschaenus* and *J. prismatocarpus*, which were described by Robert Brown in his *Prodromus*, but subsequently united by Bentham under the name *J. prismatocarpus*.

J. H. Maiden † supplies notes on critical species of *Eucalyptus*, and R. T. Baker ‡ embodies the results of his researches on *Eucalyptus melanophloia* in an amended description.

W. V. Fitzgerald § describes several new species of seed-plants from Western Australia.

**Plant Teratology.** || — O. Penzig describes an abnormal flower of *Gladiolus segetum* in which the members of the inner perianth-whorl had become doubled, and which was tetrandrous from the development of an anterior median stamen; the ovary was also six-chambered. He also figures an ascidial formation at the apex of leaves of *Smilax aspera*, and some remarkable accessory leaf-blade formations in *Carica Papaya*.

**Plant Microscopy.** ¶ — C. Zimmermann describes the use of the Microscope and its appurtenances for the benefit of students of botany. Also forms of microtome and methods of fixing and preparing material for examination.

## CRYPTOGAMS.

### Pteridophyta.

**Fern Study in North America.** — *The Fern Bulletin* \*\* celebrates the completion of the tenth year of its existence and contains papers by G. E. Davenport, W. N. Clute, and L. M. Underwood upon the past, present, and future of fern study in North America. Other papers are contributed on British Fern Culture, by C. T. Drury; New Zealand Ferns and Fern Study, by G. E. Smith; Notes on Japanese Ferns, by Kiichi Miyake; A New Equisetum, by A. A. Eaton; and a Historical Sketch of the Linnean Fern Chapter (the Club who started the periodical), by B. D. Gilbert.

**Cuban Ferns.** †† — L. M. Underwood and W. R. Maxon describe four new species of ferns recently gathered in Eastern Cuba by L. Pollard and W. and E. Palmer. The collection contains 425 plants, of which 144 were ferns. Notes are published on thirteen other species, new, rare, or confused.

### Bryophyta.

**Rhizoid-Initials of Marchantia.** †† — F. Quelle discusses the so-called rhizoid-initials in the ventral scales of the Marchantiaceae, and shows that in many cases they have been confused with the oil-body cells though easily distinguishable from them. He quarrels with the expression initial-cells, on the ground that the rhizoid may arise from any

\* Tom. cit., pp. 210-3.

† Tom. cit., pp. 214-24.

‡ Tom. cit., pp. 225-9 (1 pl.).

§ Tom. cit., pp. 241-5.

|| Malpighia, xvi. (1902) pp. 164-78 (3 pls.).

¶ Broteria, i. (1902) pp. 49-75 (8 figs.).

\*\* Binghamton, N.Y., 1902, vol. x. No. 4, pp. 97-128 (1 pl.).

†† Bull. Torrey Bot. Club, xxix. (1902) pp. 577-84 (1 pl.).

‡‡ Hedwigia, xli. (1902) Repertorium, pp. 174-7.

cell of the ventral scale except the oil-body cells. He provides a key by which the five commonest Marchantiaceous hepatics can be distinguished from one another by characters of the ventral scales, namely, by the appendages and the oil-bodies.

**Riella.**\*—L. Corbière discusses the hepatics *Riella gallica* Trab. and *R. Battandieri* Trab., and shows that the former is not dioicous as has always been supposed, but is monoicous like the Algerian species *R. Battandieri*, and is but the French form of that species and must therefore be reduced. The mistake arose owing to the fugacious character of the antheridia which disappear after discharging their contents.

**British Hepatics.**†—H. W. Lett has published a list, with descriptive notes, of all the species of hepatics hitherto found in the British islands. It is written in simplified English. Each species receives ten to twenty lines of description with notes appended in small type. A key to the genera is given at the beginning of the book, and keys to the species are placed under the genera. The scheme of classification of both the genera and the species is peculiar to the book. A bibliography and index are supplied.

**Hepatics of Baden.**‡—K. Müller publishes a list of his gatherings of hepatics in Baden in 1901, mostly from the Feldberg neighbourhood. He adds eight species and three varieties to the flora of Baden. Full descriptions and critical notes are added where necessary.

**North American Hepatics.**—A. W. Evans§ describes and figures a new species of hepatic, *Diplophyllia apiculata*, which is not uncommon in the Eastern United States, and has long been known, but has been confused with other species. The author shows that it differs from *D. obtusifolia* and *D. taxifolia* in its inflorescence and its apiculate leaves.

W. C. Barbour|| continues his monograph of the species of *Radula* found in the United States, and gives an annotated list of nine species and a key.

A. W. Evans¶ publishes notes on fourteen hepatics which are additions to the flora of New England, and indeed several of them new to the Eastern States. All but two of them occur in Europe. Incidentally several confusions of synonymy are cleared up.

**New Zealand Hepatics.**\*\*—E. S. Salmon describes and figures a new species of hepatic—*Isotachis Stephani*, discovered in New Zealand. It is a robust species of a genus which is remarkable for the close resemblance of its amphigastria and leaves. The original description †† is reproduced with additional notes by R. Brown, the collector of the plant.

**Interconversion of Sexual Organs in a Moss.**‡‡—E. de Bergevin describes an anomaly that occurs in the inflorescence of a form of the

\* Revue Bryologique, xxix. (1902) pp. 109-14 (fig. in text).

† Aghaderg, Co. Down, 1902, 8vo, viii. and 199 pp.

‡ Beih. z. Bot. Centralbl., xiii. (1902) pp. 91-104.

§ Bot. Gazette, xxxiv. (1902) pp. 372-5 (1 pl.).

|| Bryologist, v. (1902) pp. 92-4. ¶ Rhodora, iv. (1902) pp. 207-13.

\*\* Trans. Proc. N. Zeal. Inst., xxxiv. (1902) pp. 325-7 (1 pl.).

†† Rev. Bryolog., xxviii. (1901) pp. 75-6.

‡‡ Op. cit., xxix. (1902) pp. 115-9 (fig. in text).

moss *Plagiothecium sylvaticum* that grows near Lisieux. The young archegonia tend to become converted into antheridia of peculiar shape, but whether they are of functional value is not known. The reason for the transformation has not yet been discovered.

**Peristome.\***—A. J. Grout publishes the fourth part of his notes on the peristome of mosses, and discusses the mechanism by which the spores of *Polytrichum* and *Buxbaumia* are shaken or puffed out of the capsule in nature. In the succeeding article he brings to a conclusion his remarks upon the nomenclature of mosses, and the confusion and anomalies resulting from the well meant efforts of incompetent reformers.

**Suppression of Redundant Moss-Species.†**—A. Geheeb publishes a series of notes upon specific names which have acquired an unjustifiable position in bryological literature. By reducing them to mere synonyms and putting them in their proper place he clears up many doubtful points. He also summarises similar work done by E. S. Salmon.

**Genus *Thamnium*.‡**—N. C. Kindberg finishes his revision of the genus *Thamnium*, and treats of 76 species which he redescribes, adding the synonyms and geographical distribution of each species. The author maintains 96 species in all,—a considerable reduction of the pre-existing total. In the concluding pages he distinguishes the individual variations of two of the species examined, one of which is *T. alopecurum*, a common British moss; he then summarises the geographical distribution of the species, and adds notes on the species which he excludes and those which he has not been able to obtain for examination. The value of the paper is much increased by the index supplied.

**Notes on *Osculatia* and *Schwetschkea*.§**—E. S. Salmon continues his series of bryological notes and shows that the rare and puzzling moss-genus *Osculatia* De Not., which had been misplaced in Meeseaceae, is identical with another moss from the Andes, *Bryum globosum* Mitt. He redescribes and figures the plant. He passes on to the genus *Schwetschkea*, and claims that in at least some of the species the inner peristome has a basal membrane.

**British Moss Flora.**—J. A. Wheldon || and A. Wilson publish an additional list of West Lancashire mosses and hepatics, adding upwards of 40 species and varieties to their previous records for the district, which turns out to be unusually rich in Sphagna.

H. N. Dixon ¶ describes four very perplexing varieties of British mosses from various mountain localities in our islands. In each case they differ remarkably from the typical form of the species to which they are referred.

J. H. Davies \*\* records the first discovery of *Weisia rostellata* Lindb. in Ireland. It was found near Lisburn, Co. Antrim, on a bank of earth dug out of a ditch. This little moss occurs in England, but is rare.

\* Bryologist, v. (1902) pp. 94-7.

† Beih. z. Bot. Centralbl., xiii. (1902) pp. 105-11.

‡ Hedwigia, xli. (1902) pp. 225-68.

§ Journ. Bot., xl. pp. 369-74 (1 pl.).

|| Tom. cit., pp. 412-6.

¶ Tom. cit., pp. 374-80.

\*\* Irish Naturalist, xi. (1902) p. 289.

W. Ingham \* supplements his previous list of Sphagna of Yorkshire and Durham by an account of the additional species and varieties found by himself in the former county.

W. P. Hamilton † publishes a localised list of the Sphagna of Shropshire, renamed in accordance with Warnstorff's revision of the genus.

**French Moss Flora.**—F. Camus ‡ records the occurrence of the Mediterranean moss *Ceratodon chloropus* Brid., on the island of Noirmoutier, on the Atlantic coast of France, and suggests that it should be looked for in other spots along that coast.

C. Meylan § reports the results of his gatherings of Muscineæ in the Jura during the past three years. He adds eleven mosses and twelve hepatics to the flora of the chain of the Jura.

Ravaud || continues his guide to the collector of mosses and lichens in the neighbourhood of Grenoble, that is to say, he records the various plants that may be gathered on the various rocks and soils passed by the wayfarer as he takes a definite walk described by the author, e.g. from La Grave to Villard-d'Arène.

**Moss Flora of French Caverns.**¶—L. Géneau de Lamarlière and J. Maheu publish a third contribution to our knowledge of the mosses which occur in underground caverns. These latter are very numerous in the Jurassic strata of the department of the Yonne in central France. Very few species of mosses occur on the surface owing to the dryness of the limestone. Some of these species occur in the caves, and with them are others which are not known to grow on the surface in the neighbourhood of the caves. The caves are dry, and the mosses growing in them are usually xerophilous and calcicolous in character, and owing to the comparative darkness are considerably modified in habit. About a score of species are recorded, and six of these are so modified that they are described as definite varieties.

**German Mosses.**\*\*—V. v. Cypers continues his list of the cryptogams of the Riesengebirge district by giving an enumeration of the pleurocarpous mosses with annotations. He distinguishes a new variety of *Brachythecium rivulare*.

**Japanese Mosses.**††—E. G. Paris publishes a list of the mosses gathered by Faurie in 1900 in the southern part of Japan, from South Nippon to the Liu-Kin Islands. He records several new species and describes twenty-two of them with the collaboration of V. F. Brotherus. Two genera, *Leucoloma* and *Trichosteleum*, were previously unknown in Japan. At the close of the paper is a list of the Japanese mosses gathered by Ferrié, and among them are several new species by C. Mueller and by Brotherus, but at present they are undescribed.

**Muscineæ of South-East Asia.**‡‡—E. G. Paris gives an account of twenty-four mosses and eleven hepatics gathered in the French posses-

\* The Naturalist, 1902, pp. 381-3. † Journ. Bot., xl. (1902) pp. 416-9.

‡ Revue Bryologique, xxix. (1902) pp. 119-20.

§ Tom. cit., pp. 120-7.

¶ Tom. cit., pp. 98-103.

|| Journ. de Bot., xvi. (1902) pp. 266-79.

\*\* Verh. k. k. zool.-bot. Gesell., lii. (1902) pp. 530-9.

†† Bull. Herb. Boiss., sér. 2, ii. (1902) pp. 918-33, 988-93.

‡‡ Revue Bryologique, xxix. (1902) pp. 93-7.

sions in Eastern Asia by various collectors. Six new species of mosses are described.

**Muscineæ of the Galapagos Islands.\***—A. W. Evans and W. G. Farlow publish lists of the hepatics and mosses respectively of the Galapagos Islands, basing their reports primarily on the collections made by Snodgrass and Heller in 1898 and 1899, but including also all the previous records for these islands, e.g. by Darwin, Andersson, Baur, Eighteen hepatics and nine mosses are catalogued; two of the former were indeterminable specifically. At least five hepatics and three mosses are endemic.

**Muscineæ of the Atlantic Islands.†**—V. Schiffner has worked up the bryophytes of the collections made by J. Bornmüller in Madeira and the Canaries in 1900 and 1901, and has found among them some novelties, several additions to the flora of the Atlantic Islands, and a number of rare species very sparingly gathered previously. He begins a list of his determinations, supplying descriptions and critical notes where necessary, and recording the geographical distribution.

#### Thallophyta.

##### Algæ.

**The Pyrocystæ.‡**—V. H. Blackman here embodies the result of observations made on living material, chiefly during a voyage to the West Indies some years ago. *Pyrocystis pseudonociluca* Wyv. Thoms. is treated in detail under the headings of structure, reproduction, distribution, and luminosity. The author succeeded in stimulating specimens of this organism by means of alcohol sufficiently to enable him to study it by its own light under a low power of the Microscope in the dark. From this examination he is led to believe that the radiation of light arises "from the mass of protoplasm surrounding the nucleus." *P. fusiformis* Wyv. Thoms., *P. Lunula* Schütt, and *P. Hamulus* Cleve are shortly treated, and remarks are then made on amyllum-bodies which occur in all four species in the form of clear, refractive bodies, either spherical, oval, or rod-shaped. The author likens them to the so-called amyllum-bodies of certain Peridineæ, though he considers that their exact nature is at present uncertain. The systematic position of the Pyrocystæ is discussed, but, owing to want of knowledge of the life-history of any of the species, the author considers their position doubtful. A synopsis of species includes the somewhat doubtful species *P. lanceolatus* Schröder. A list of references closes this paper. The plate contains figures of the four established species.

**Minute Structure in Triceratium.§**—A. A. Merlin finds *T. parallelum* and one of its varieties, *T. glandiferum*, possess a "delicate lacework structure apparently covering the whole of the silex composing the

\* Proc. Amer. Acad., xxxviii. (1902) pp. 100-4.

† Hedwigia, xli. (1902) pp. 269-72.

‡ New Phytologist, i. (1902) pp. 178-88 (1 pl.).

§ Journ. Quek. Micr. Club, ser. 2, viii. (1902) p. 267.



upper surface of the valve, and extending to, and closely surrounding the primaries." The structure is exceedingly faint and minute, but the author feels convinced that it really exists.

**Phytoplankton of the Thames.\***—F. E. Fritsch gives a preliminary note on the result of his investigations made during six separate days in July and August of last year. The portion of the river examined extends from Kew to Cookham, and the samples were collected from a rowing-boat by means of an ordinary funnel-shaped net of fine gauze, having the lower narrow end attached to a glass tube. The quantity of plankton organisms decreases steadily down the river, and at Kew, where the tidal influence is felt, the desmids and pediastrums are either dead or dying, while many of the diatoms consist of mere empty frustules. The author attributes this to the influence of the brackish water, which enables purely marine species (*Coscinodiscus radiatus*, *Surirella ovata*, and *Rhaphoneis Rhombus*) to exist at Kew. Diatoms play an important part in the upper reaches examined, the proportion at Windsor and Maidenhead being about 20 to 1. The commonest forms are *Fragilaria virescens*, *Melosira varians*, *M. moniliformis*, *Pleurosigma attenuatum* in the surface layers, species of *Surirella*, and in parts *Campylodiscus noricus*. Among green algæ the most common forms were *Pediastrum Boryanum* and *P. pertusum*, *Closterium moniliferum*, *Cosmarium margaritifera*, and *Scenedesmus quadricauda*. Species of Cyanophyceæ occur more frequently in the lower parts of the river, the commonest forms being *Microcystis protogenita* and *M. marginata*. No Peridiniaceæ were observed.

A table is given in which are enumerated fifty-four species and five varieties, together with their distribution and the relative number of individuals found.

**Variations-Statistics as applied to Plankton-Diatoms.†**—P. Vogler writes a preliminary note on the importance of applying this method of investigation to plankton. He expresses his results in curves, and is of opinion that by this method only can a true conception be formed of the dimensions of a given species. He maintains that average measurements are of no value. He has devoted five years to this research.

**Diatomaceæ of the Hull District.‡**—F. W. Mills and R. H. Philip publish an illustrated list of the diatoms occurring in the neighbourhood of Hull—to the number of about 600 species and varieties, which is a considerable advance upon the lists published by G. Norman in 1859 and 1865, which contained about 400 and 480 species respectively. The present list in fact represents nearly half the species that are found in the British Isles. In what is here called the Hull district are included places within reach of a half-day excursion from Hull. Each species and variety is figured. Most of the figures have been taken from Schmidt's *Atlas*, Van Heurck's *Synopsis*, and other standard and minor works; but some have been drawn specially. The nomenclature and classification are mainly those which have been adopted by

\* *Ann. Bot.*, xvi. (1902) pp. 576-84.

† *Flora*, xci. (1902) pp. 380-3.

‡ *Trans. Hull. Sci. and Field Nat. Club*, i. (1901) p. 157 (17 pls.).

Van Heurck. Synonymy is excluded save in so far as it is necessary for keeping in touch with Norman's lists. Attention is called, in the introduction, to the fixity of certain species in certain localities, and, on the other hand, to the appearance or disappearance of other species in other places, for reasons at present unknown. Norman's slides have been submitted to re-examination.

**Limosphenia, a New Genus of Diatoms.\***—C. Mereschkowsky finds his new genus *Limosphenia* on diatoms collected at Villefranche, and places in it five species—*L. Grunowii*, *L. Clevei*, *L. Peragalli*, *L. Schmidtii*, and *L. Van Heurckii*. He gives a full description and figures of each species. The genus is intermediate between *Licmophora* and *Climacosphenia*, from which it differs in the disposition and perforations of the septa. In *Licmophora* the septa are perforated by a single large orifice; in *Climacosphenia* there are several such orifices, and in *Limosphenia* there are two only. The paper ends with a key to the species.

**Reproduction of Valonia.†**—P. Kuckuck gives a short preliminary account of the mode of reproduction in *Valonia ovalis*. Several days before the spores are ripe and ready to escape, certain delicate markings become visible on the wall of the mother-cell, and dark-green agglomerations of protoplasm are found in the shape of rings or branched bands. The cell-membrane covering this portion of the mother-cell then develops thin spots, around which the masses of protoplasm gradually split up (*zerklüften*), the membrane breaks, and the zoospores escape. The posterior end of the zoospore is deeply coloured and full of starch, the anterior portion being colourless and having two cilia. No eye-spot was to be seen, and the zoospores did not unite in pairs. After a time the mother-cell resumes its normal colour, the openings close up, and eventually the process of reproduction is repeated. It is remarkable that the zoospore is not divided off from the surrounding protoplasm by any cell-wall; and since the contents of the mother-cell are at the time of the escape of the zoospores in direct contact with the outer world, considerable firmness of the membrane is necessary to prevent collapse of the entire cell.

**New Genus of Siphonæ.‡**—A. Ernst finds a new genus, *Dichotomosiphon*, for the reception of the alga which till now has been known as *Vaucheria tuberosa* A. Braun. His paper on the subject is divided into (i.) Vegetative Organs; (ii.) Reproduction; (iii.) Systematic Position of *Dichotomosiphon*. Under the first heading the branching is described as beginning in a dichotomous manner, and ending as tri- or sometimes penta-chotomous. The cell-membrane and cell-contents, including chlorophyll- and starch-grains, are treated in detail, and the similarity is pointed out which exists between this genus and Codiaceæ. Under Reproduction are described the oogonia and antheridia, which arise terminally on short special branches. The development of each has been traced, and is here described, together with an

\* *La Nuova Notarisia*, 1902, pp. 177-83 (5 figs. in text).

† *Ber. Deutsch. Bot. Gesell.*, vii. (1902) pp. 355-7.

‡ *Beih. Bot. Centralbl.*, xiii. (1902) pp. 115-48 (5 pls.).

account of the fertilisation and of the resulting oospore. Attempts to follow the germination of the latter have so far been unsuccessful. Besides the sexual method of reproduction, there exists in *Dichotomopsis* an asexual form of reproduction which is unlike anything known till now among the Siphonæ. Unbranched, rhizoid-like filaments arise on the plant, and these bear tubercles, which become thick in protoplasm, and germinate after being cut off by a transverse wall from the rhizoid-like filament.

As regards the systematic position, the author places this genus nearest to *Vaucheria*, from which, however, it has many points of difference. A striking resemblance exists in certain points to *Halimeda* and *Codium*, but especially to a still undescribed, young condition of *Udotea*. A full diagnosis, followed by references to literature, closes this paper. The various conditions described are figured in coloured plates.

**Cell-Membrane of Desmidiaceæ.\***—J. Lütkenmüller has made an exhaustive study of this subject, and now publishes the result of his nine years' work. Several hundred species were examined, and the author is enabled to divide the family into five groups of genera, which are sharply distinguished from one another by constant anatomical and physiological characteristics. The types of the five groups are *Cosmarium*, *Closterium*, *Penium*, *Gonatozygon*, and *Spirotania*. The cell-membrane, pore-apparatus, and cell-division of the various types are dealt with, and remarks are made on the position of the genus *Penium*, relationship of the types, function of the pore-apparatus, and systematic treatment. Finally a synopsis of genera in Desmidiaceæ is given, drawn up on the lines of classification propounded by the author.

**Ulotrachaceæ and Chætophoraceæ of the United States.†**—T. E. Hazen publishes the result of five years' study on these groups of algæ. After giving short accounts of his method of study and methods of preservation, he gives some remarks on their distribution, which, he says, is still somewhat doubtful from the unreliability of so many records. Then follows the systematic treatment of the two groups, in which the author gives diagnoses of the families and genera, with keys to genera and species. After the name of each species are given synopses and references to literature, a diagnosis, references to Exsiccata, habitats and distribution, and finally critical notes. Ten new species are described, and three new forms or varieties. The author has endeavoured to emphasise cytological, and especially chromatophore characters as much as possible, but in many cases he has been reluctantly compelled to fall back on the character of cell-measurements "to separate species which, after careful observation, he is convinced are distinct." A list of bibliography and an index complete this paper.

**Ædogonium.‡**—F. E. Fritsch has made a detailed study of the young root-ends of five species of this genus, and comes to the conclusion that certain types are characteristic of certain species. It is generally found that the form of the root-end varies, according to whether

\* Beitr. z. Biol. d. Pflanzen, viii. (1902) pp. 347-414 (3 pls.).

† Mem. Torr. Bot. Club, xi. (1902) pp. 135-250 (23 pls.).

‡ Ann. Bot., xvi. (1902) pp. 467-85 (3 figs. in text).

the young plant is free or attached. Air-bubbles are often found in connection with the floating individuals, probably formed from the plant itself. The author shows that though the first cap of the young plant may be, and often is, thrown off, this is by no means the rule. In certain plants there is an abnormal zoospore formation, in which the zoospores are either not liberated at all, or they only exhibit a very sluggish movement. In the latter case, the germinating zoospore produces very strange forms of young plant.

**Vegetative Reproduction of *Dasya elegans*.**\*—F. Tobler describes the result of experiments made by himself on the growth of *Dasya elegans* under various conditions of light. Certain plants of this species were cultivated in a vessel close to a window, with the result that after two days the thallus had shed all the penicilli, as well as the smaller branches, which were lying at the bottom of the glass vessel. These fallen branches were seen to sprout, and the author describes and figures the various stages of the process. He was able to compare with this form of reproduction the normal growth of a plant from tetraspores, since the cultures were carried on simultaneously. The power of reproduction from vegetative cells is not confined to the monosiphonous portions of the thallus, but was also observed among cells which formed the cortex of the polysiphonous axis. Various stages of growth are figured.

**New Genus of Delesseriaceæ.**†—F. Heydrich creates a new genus *Implicaria* for the reception of a species *I. reticulata* from Loochoo, Japan. The specimen described exists in the Berlin Herbarium, and in certain points resembles *Vanvoorstia* and *Claudea*, with which the author compares it. He also gives the points of resemblance and difference between his plant and *Holmesia capensis*.

**Spiral Arrangement in Florideæ.**‡—S. Schwendener criticises adversely the views held by Falkenberg and Rosenvinge on this subject. The author states that his own experience leads him to disbelieve in the continuous spiral with constant divergence in *Polysiphonia*, and states the reasons for his scepticism.

**Caloglossa Leprieurii.**§—Marshall A. Howe publishes some remarks on this species, which occurs in North and South America, as well as in other parts of the world. He gives the views of authors on the question of the migration into fresh water of several species of *Caloglossa*.

**Catalogue of British Marine Algæ.**||—E. A. L. Batters publishes a complete list of all the British marine algæ, together with the localities where each species and variety occurs in the British Isles. The number of genera is 259, including five of doubtful affinity. The nomenclature followed is that adopted by all algologists on the Continent and in America. This catalogue is as complete as it is possible to make it,

\* Ber. Deutsch. Bot. Gesell., xx. (1902) pp. 357-65 (1 pl.).

† Tom. cit., pp. 479-83 (1 pl.).

‡ Tom. cit., pp. 471-5.

§ Torreya, ii. (1902) pp. 149-52.

|| Journ. Bot., xl. (1902) Supplement, pp. 1-107.

since the author has not only published the records of his own extensive collection, but he has included those of the public Herbaria and many private collections.

**Marine Algæ of the Faeroes.\***—F. Børgesen publishes a complete list of the marine algæ of these islands founded on his own and other collections. He has himself examined the marine flora of the Faeroes at various seasons of the year, and his own observations, taken together with his examination of the various collections, enable him to form a definite idea of the development of the algæ from April to December. To the record of each alga there are appended critical notes with figures in the text, and in many cases details are very fully discussed and interesting observations recorded.

Two new species of *Myrionema* are described and one each for the genera *Phaeostroma*, *Laminaria*, *Dermocarpa*, and *Hyella*. An index, which includes the more important synonyms, especially those of Lyngbye, and a coloured map of the Faeroes taken from the Danish Government Survey, complete this volume.

**Marine Algæ from Dago.†**—Nils Svedelius enumerates eleven species of marine algæ and five species of *Chara*, collected by O. A. F. Lönbohm, from this island in the Baltic. A few critical remarks follow on the forms of *Fucus vesiculosus* which occur there. The author is of opinion that the *angustifolia* and *subecostata* series is distributed to the eastward, and the *filiformis* series to the westward of the Baltic shores.

**Australasian Sphacelariæ.‡**—Camille Sauvageau publishes short notes on the morphology and distribution of species of *Sphacelaria* from Australasian seas. Many of the specimens examined by him belong to the Harvey Herbarium in Trinity College, Dublin. The same author has dealt fully with this group in the *Journal de Botanique*, where the new species are described. Of the thirty-six species there cited, thirteen are peculiar to Australasia, and five are common to this and other regions. The author finds that an examination of specimens of Australasian Fucaceæ is productive of good material of *Sphacelaria*, and he believes that a careful search for these plants round the shores of Australia, New Zealand, &c. would have rich results; since many of the specimens known hitherto have only been collected by chance, as growing on other and larger algæ.

**Algæ of the Galapagos Islands.§**—W. G. Farlow publishes a list of 45 species of algæ from these islands, 43 being marine. One new species of *Glossophora* and one of *Dasya* are described, and a new genus is founded provisionally, *Herpophyllon*, for the reception of an alga, *H. coalescens*, which has cruciately divided tetraspores in wart-like sori; the cytocarps are still unknown. The thallus is prostrate and membranaceous, suggesting *Peyssonelia rugosa* at first sight.

\* 'Botany of the Faeroes,' part ii., Copenhagen, 1902, pp. 339-532 (figs. 51-110 and map).

† Bot. Notiser, v. (1902) pp. 225-8.

‡ Notes from Bot. School. Trin. Coll. Dublin, v. (1902) pp. 196-200.

§ Proc. Amer. Acad., xxxviii. (1902) pp. 89-99.

**New Zealand Marine Algæ.\***—R. M. Laing concludes his list of New Zealand algæ begun two years ago, and enumerates 291 species of Floridææ. Three species of Chlorophyceæ are given in an addendum, bringing the list up to 389 in all, including the contents of this and the previous paper. In this part a new species of doubtful position is described, *Nitophyllum microphyllum* Crosby Smith, and a new variety, *tumescens* of *Champia Nova-zelandiæ* Hook. et Harv.

#### Fungi.

**Fertilisation in the Phycomycetes.†**—W. Ruhland publishes a preliminary note on this subject which he has studied in *Albugo Lepigoni* and in several species of *Peronospora*. A more detailed paper will appear later.

**Amylomyces Rouxii.‡**—J. Turquet has conducted a series of culture experiments on this Chinese "yeast" used in the fabrication of wines and spirits from rice. He has succeeded in growing the aërial form, a branched *Mucor* with brownish sporangia and minute oval spores. Chlamydo-spores are also formed in the hyphæ. The author names it *M. Rouxii*.

**Sprouting of Yeast-Cells.§**—Albert Hirschbruch concludes his paper on the development of yeast-cells. He follows out the division of the nuclei, and the accumulation of protoplasm in the daughter-cell which remains attached to the mother-cell until it is of sufficient size to be independent. In the species studied by him, *Saccharomyces ellipsoideus* Hansen, division of the nucleus is by mitosis. The plate in illustration of the paper is to be published in the following number of the journal.

**Spore-formation in Yeast.||**—M. A. Guillermond has studied this subject in *Saccharomyces Ludwigi*. It had been noted by Hansen that in this species the yeast-cell produced a germinating tube which he called a promycelium, and from which were formed the new cells. Guillermond finds that there is frequent conjugation between two cells and fusion of nuclei previous to new cell-formation.

**Origin of Yeast.¶**—G. Odin contributes a note on this question. He has been experimenting with forms of *Penicillium*, and he finds that by cultivation from the spores he obtains in a few generations a yeast form that is perfectly stable, and will continue to form yeast-spores even on solid substances. The writer has not yet determined if these yeasts so obtained will remain indefinitely stable.

**Cell-Nucleus of Saccharomycetes and Bacteria.\*\***—Marpmann discusses the present state of our knowledge as regards the presence of nuclei in yeast and bacteria. In the former the nucleus had

\* Trans. and Proc. New Zeal. Inst., xxxiv. (1901) pp. 327-59.

† Hedw. Beibl., xli. (1902) pp. 178-80.

‡ Comptes Rendus, cxxxv. (1902) pp. 912-5.

§ Centralbl. Bakt., ix. (1902) pp. 513-20.

|| Comptes Rendus, cxxxv. (1902) pp. 708-10.

¶ Tom. cit., cxxxv. (1902) pp. 479-81.

\*\* Centralbl. Bakt., ix. (1902) pp. 357-61.

been observed by many workers. Wager demonstrated that the reputed nucleus was the nucleolus only, and that in the vacuole of the yeast-cell he had observed nuclear threads. Marpmann gives an account of the methods whereby he has clearly proved the existence of nuclei both in yeast and bacteria. He immerses the preparations of bacteria in pure carbolic acid after fixation, thus rendering the nuclei more susceptible to staining. The author has also experimented with several species of *Schizosaccharomyces*. He classifies the yeasts primarily by their colours, as white, grey, yellow-brown, yellow-red, and black yeasts.

**New Sphærospideæ.\***—F. Tassi describes three new genera belonging to this group:—*Trigonosporium*, distinguished by its trigonous hyaline spores, found on dead branches from Sydney; *Santiella*, with fusiform, 2-celled, brown spores, probably the pycnidial form of *Caryospora*; and *Hyalothyridium* which resembles *Camarosporium*, but with brown spores. The species of the two latter genera were found in the Botanical Garden at Siena.

**Development of *Dipodascus albidus*.†**—This minute fungus was first discovered by Lagerheim in Ecuador, and by him described and classified as one of the Hemiasci, specially notable as possessing distinctly sexual fructification. H. O. Juel has recently found the same fungus in Sweden on a fallen birch stem, and he has worked out the different stages in the development of the sexual organs and of the spores. The former arise as projections on one of the hyphæ, from which they are cut off after fusion. Each cell contains also several small vegetative nuclei. After copulation a larger nucleus appears, evidently the result of fusion. The ascus grows out from the conjoint cell, and the nuclei increase by free cell-formation from the large nucleus. These cells become clothed with a cell-wall and form the spores. The author discusses the systematic position of this fungus. He considers that it forms a link between the Phycomycetes and the Ascomycetes.

***Nectria moschata*.‡**—H. Gluck gives an account of the occurrence and life-history of this fungus which forms gelatinous masses in water-pipes and on damp wood. The formation of perithecia and the development of the spores is described.

***Cordiceps Robertsii*.§**—H. Hill publishes a historical and descriptive account of this fungus which has been called the "vegetable caterpillar." It is found all over the North Island of New Zealand. The author has not been able to determine the species of caterpillar attacked by the fungus, and his attempts to germinate the spores on other caterpillars have been as yet unsuccessful.

**Gooseberry Mildew.||**—P. Magnus is of opinion that *Sphærotheca mors-uvæ* is not indigenous in Europe, but that it has been imported from America. He also demurs to the opinion that it is identical with

\* Bull. Laborat. et Orto Bot., iii. pp. 89-92 (2 pls.). Cf. Centralbl. Bakt., ix. (1902) p. 506.

† Flora, xci. (1902) pp. 47-55 (2 pls.).

‡ Engl. Bot. Jahrb., xxxi. (1902) pp. 495-515 (2 pls.).

§ Trans. and Proc. New Zeal. Inst., xxxiv. (1902) pp. 396-401 (1 pl.).

|| Gartenfl., Jahrg. li. (1902) p. 3.

*S. tomentosa* found on *Euphorbia*, as the latter occurs very frequently in regions where the other is as yet unknown.

**Diseases of the Vanilla.\***—G. Delacroix reviews Masee's work on the parasitic fungus *Calospora Vanilla*. He finds that the measurements and descriptions given by Masee do not tally with those of the fungus causing the Vanilla disease. He determines the fungus to be a *Vermicularia* with its conidial form *Colletotrichum Vanilla*. He gives an account of the disease as it affects the trees, with descriptions of the various fungi associated with the attack, and suggests the best means of cure.

**Disease of Bananas.†**—G. Delacroix calls attention to the black discoloration so often seen on Banana fruits. It is caused by the growth of a fungus *Glaeosporium Musarum* Cooke and Mass., which form little red conceptacles on the black spots. The tissue of the fruit underneath is yellow and full of the mycelium of the fungus. It is a wound parasite only.

**Laboulbeniaceæ.‡**—Roland Thaxter publishes a considerable addition to these species of fly-inhabiting fungi. The new genera are *Herpomycetes*, *Acallomyces*, *Ecteinomyces*, and *Coreomyces*. He adds 40 new species to the genus *Laboulbenia*.

**New French Lichen Flora.§**—A. Boistel has just issued the second part of his *Flore des Lichens*. It follows the lines of classification laid down in the volume published by him in 1896, taking the vegetative development rather than the reproductive organs as the more important feature. The book is arranged in the form of a key to the Lichens. There are many forms not included in the previous more elementary publication, but there are no illustrations of species. Boistel gives, as a rule, the habitat of the plant, but not the locality.

**Lichen Flora of the Tyrol.||**—The fourth volume of a general Flora of Tyrol, Voralberg, and Lichtenstein has just appeared. It represents the Lichens and is based on the work of many previous botanists. A history of the work already done on this subject is given in the preface, with special mention of the journeyings and collections of Ferdinand Arnold to whom the volume is dedicated. A full index is given, with a list of the places mentioned and their altitude. A map of the district is also provided.

**Rare Lichen from Liguria.¶**—E. Morteo describes a specimen of *Cladonia turgida*, a somewhat rare lichen. It was collected for the first time in Italy by Ab. Martin in 1867.

\* Bull. Soc. Myc., xviii. (1902) pp. 274-83 (1 pl.).

† Tom. cit., pp. 285-7 (4 figs.).

‡ Proc. Amer. Acad. Arts and Sci., xxxviii. (1902) pp. 9-57.

§ Nouvelle Flore des Lichens, 2<sup>e</sup> partie, by A. Boistel, Paris, 1902, pp. xxxiii. and 332 (1 pl.).

|| Die Flechten (Lichenes) von Tirol, Voralberg und Lichtenstein, by Prof. Dr. K. W. v. Della Torre und Ludwig, Graf von Sarnthein, Innsbruck, 1902, pp. xlv. and 936.

¶ Atti Soc. Lig. d. Sci. Nat. e Geog., xiii. (1902) pp. 113-4.



**Lichen Flora of Algiers.\***—J. Steiner publishes a second list of lichens from Algiers, from material collected by Fr. v. Kerner. He determines a number of new species and one new genus *Gonohymenia*. The collection is preserved in the Botanical Museum of the University at Vienna.

**Umbilicaria in N. America.†**—C. W. Harris continues her study of the lichens of the United States, and monographs briefly the genus *Umbilicaria*, in which she merges *Gyrophora*. She describes all the twelve species in simple terms. Four of the species are photographically figured in the plate.

**Californian Lichens.‡**—A. Zahlbruckner describes a number of new species sent to him by H. E. Hasse from Los Angeles. He finds one new genus among the number, *Hassea*, founded on *Verrucaria bacillosa*, and placed by him in a group Pyrenidiaceæ. These are all characterised by the *Nostoc* or *Scytonema* character of the gonidia and by the simple straight apothecia.

**Perforation of Vine-Leaves.§**—V. Brizi finds that this is due to the action of a fungus, *Gleosporium ampelophagum*, which attacks the young leaves, causing a yellowing of the tissue. Later, the pustules of the fungus appear on the spots, and in time the diseased part of the leaf drops out.

**New Parasitic Botrytis.||**—A disease of the fruits of *Diospyros Kaki* has been found by V. Brizi to be due to a species of *Botrytis*, which he has called *B. Diospyri*. It attacks the calyx, and the fruits drop off before they are ripe.

**Black Spot of the Apple.¶**—The mould *Fusicladium* which produces black spots on apples and pears has been causing great loss to fruit-growers in Australia and Tasmania. D. McAlpine has given a description of the fungus, with an account of its life-history. The winter stage, *Venturia inaequalis* and *V. pyrinum*, have been found by him recently, but he considers that the mould is usually propagated from year to year by the conidia which become entangled in the hairs and bud-scales, and that the appearance of the *Venturia* stage is unnecessary to the continued life of the parasite. He gives a detailed account of spraying experiments and instructions as to the best sprays to use and the method of preparing the mixtures.

**Diseased Pelargoniums.\*\***—G. Masee has found that the South African rust *Puccinia granularis*, which grows on native Geraniaceæ, had transferred itself to the leaves of pelargoniums imported from England and France. The diseased leaves were sent from the Transvaal.

\* Verh. d. k. k. Zool. Bot. Ges. in Wien, lii. (1902) pp. 469-87.

† Bryologist, v. (1902) pp. 89-92.

‡ Beih. z. Bot. Centralbl., xiii. (1902) pp. 149-63.

§ Le Staz. Sperim. Agrarie Ital., xxxiv. (1901) pp. 774-88. Cf. Centralbl. Bakt., ix. (1902) p. 613.

|| Le Staz. Sperim. Agrarie Ital., tom. cit., pp. 767-77. Cf. Centralbl. Bakt., loc. cit.

¶ Bull. No. 3 Dept. of Agric. Victoria, 1902, 29 pp. (4 pls. and 2 figs.).

\*\* Journ. Roy. Hort. Soc., xxvii. (1902) pp. 172-3 (5 figs.).

**Monograph of the Uredineæ.\***—The second fascicle of P. and H. Sydow's great work has now appeared. It includes species of *Puccinia* on plants of the natural orders Goodeniaceæ to Umbelliferæ. The plates illustrate the different forms of the teleutospores; they contain 155 figures.

**Specialisation of Rusts.†**—Jakob Eriksson continues his researches on the forms of *Puccinia graminis*. He has carried out infection experiments in Sweden on a large number of grasses, and he gives detailed tabulated results with extensive notes on the phenomena observed. He also contrasts his results with those arrived at in America by similar experimenters. He finds that the prevailing forms in the two countries do not agree, even on the same host-plants. Specialisation has proceeded on different lines.

**Rust on Vanilla.‡**—G. Delacroix found on some fruits of vanilla from Tahiti, not only the form of disease due to *Glæosporium Vanilla*, but the uredospores and teleutospores of a species of *Uromyces*. Careful examination proved it to be a new species, *U. Joffrini*.

**Experiments on the Brown Rust of Bromes.§**—E. M. Freeman has continued a part of the work begun by Marshall Ward, the special object in the investigation being to test the infection capabilities of numerous species of *Bromus* and so determine more accurately the systematic position of the grasses. Uredospores of *Puccinia dispersa* were used from sori on *B. mollis* and *B. sterilis*. A series of 22 species is given that could not be successfully infected with either set of spores; 12 species were susceptible to the spores from *B. mollis*, but not to those of *B. sterilis*; 5 species are given in which infection from both was successful, but in very varying degree. The writer gathers evidence from these experiments as to the connection of these Bromes with the *mollis* or *sterilis* group.

**Researches on Rusts.||**—E. Fischer has published an account of his infection experiments with various Uredineæ. He deals with the Pucciniæ of *Polygonum Bistorta*, and also with species of *Cronartium*, *Melampsorella*, and *Thecopsora*. The growth of the latter, *Thecopsora Puli*, was induced on *Prunus virginiana* by infection of the spores of *Æcidium strobilinum*, and the uredospores appeared a second year on the *Prunus*.

**Genus Amanita.¶**—M. E. Boudier gives a review of the principal species of this genus with exhaustive notes. He includes 3 species of *Amanitopsis*, which he considers a sub-genus.

**North American Polyporeæ.\*\***—W. A. Murrill has studied the genus *Ganoderma*. There are 7 representatives of the genus in N. America, several of which are described for the first time. *Polyporus lucidus*, the

\* P. and H. Sydow, *Monographia Uredinearum*, vol. i. fasc. ii. Leipzig, 1902, 192 pp. and 12 pls. † *Centralbl. Bakt.*, ix. (1902) pp. 590-607.

‡ *Bull. Soc. Myc.*, xviii. (1902) p. 284 (4 figs.).

§ *Ann. Bot.*, xvi. (1902) pp. 487-94.

|| *Ber. d. Schweiz. bot. Ges.*, xii. (1902) p. 9. Cf. *Bot. Zeit.*, lx. (1902) p. 246.

¶ *Bull. Soc. Myc.*, xviii. (1902) pp. 251-73 (1 pl.).

\*\* *Bull. Torrey Bot. Club*, xxix. (1902) pp. 599-608.

type of the genus, is referred back to Jacquin's name. He figured and described it as *Agaricus pseudoboletus*. It has been finally named *Ganoderma pseudoboletus*.

*Lentinus lepidius*.\*—P. H. Dudley gives an account of this fungus and of the damage it does to timber and to yellow-pine cross-ties on railway tracks.

**New Member of the Phalloideæ.**†—P. Hennings has described a fungus sent to him by A. Klitzing from Mecklenburg, which he has identified as a variety of *Anthurus borealis* Burt, recorded from N. America, and the only species that has been found in temperate lands. Hennings decides from evidence supplied to him by Klitzing that the plant is indigenous to N. Germany. He discusses *Anthurus* and neighbouring genera, and considers that the species of *Anthurus* should be classified with those of the genus *Lysurus*. He therefore renames the species under discussion as *Lysurus borealis* var. *Klitzingii* P. Henn.

**Genera of Gastromycetes.**‡—C. G. Lloyd gives an account of the general structure of the group, makes a few critical remarks on previous attempts at the classification of its members, and suggests a system of arrangement in tribes of the genera of Lycoperdaceæ. Four tribes are recognised: Tylostomeæ, Podaxineæ, Sclerodermeæ, and Lycoperdæ, based on characters of stalk and capillitium. The genera are illustrated by photographic reproductions. Further notes on Lycoperdæ will be found in the Mycological Notes, No. 9, by the same author.

**Fungi of the Setubal Region.**§—C. Torrend communicates the first part of a fungal flora of this Portuguese district. It includes the Hymenomycetes and the beginning of the Gasteromycetes. It contains descriptions of several new genera and species by Bresadola.

**Fungus Flora of Sonntagberg.**||—P. P. Strasser publishes a second contribution of 118 species of the fungi of this region of North Austria. There are several new species determined by Bresadola, a new genus of Sphærospideæ, *Strasseria* Bres. and Sacc., and a genus of Phæostilbeæ, *Höhneliella* Bres. and Sacc., each with one species. The list now extends to 856 species.

**Fungi of Piedmont.**¶—T. Ferraris is examining the Cesati cryptogamic herbarium, and publishes a first list of the micro-fungi he has determined. It includes the Ustilagineæ, Uredineæ, Phycomycetes, and Perisporeæ. The author gives notes and observations on many of the species.

**Japanese Fungi.**—P. Hennings\*\* gives a systematic list of fungi comprised in various collections made in Japan. Several new species are described.

\* Journ. New York Micr. Soc., xvi. (1901) pp. 5-12 (figs. in text).

† Hedw. Beibl., xli. (1902) pp. 169-74 (8 figs. in text).

‡ Bull. Lloyd Library, Mycolog. Series No. 1 (1902) 24 pp. (11 pls.).

§ Broteria, i. (1902) pp. 94-150 (1 pl.).

|| Verh. d. k. k. Zool.-bot. Ges. Wien, lii. (1902) pp. 429-37.

¶ Ann. d. R. Ist. Bot. di Roma, ix. (1902) pp. 187-220.

\*\* Engl. Bot. Jahrb., xxxi. (1902) pp. 728-42; and xxxii. (1902) pp. 34-6.

P. Dietel\* gives a further instalment of his notes on Japanese Uredineæ.

P. Dietel† also describes four new species belonging to this group sent to him from Tokio.

Notes on American Fungi.‡—C. G. Lloyd criticises the genus *Stella* of Masee, and suggests its identity with a *Scleroderma*. He also notes that the American *Lycoperdon separans* is the same as the European *L. cruciatum*, and describes a new species from Washington D.C., *L. pseudoradicans*. G. Bresadola describes a new species which has the habit of a *Cordyceps* and the fructification of a *Hypocrea* as *Hypocrea Lloydii*; it was found in West Virginia. Figures of other fungi are also given.

Fungus Diseases in Australia.§—Dr. McAlpine has just issued an exhaustive account of the fungi that have been found on stone-fruit trees, almond, apricot, cherry, peach, and plum. He describes the attacks and the best way to remedy them, and then gives a technical description of the fungi, 117 in all, as they occur on stem, root, leaves or fruit. Many of the species are new to science, but not all are originators of disease, 38 only are parasitic, the others are saprophytes and harmless. There are abundant illustrations which should help the growers to identify the fungi and determine their nature. Of the plates 10 are coloured and represent the diseases most commonly met with in the colony.

Fossil Fungi.||—L. Pampaloni has studied the minute flora and fauna of the miocene deposits of Dysodile, which is an inflammable shale found at Melilli in Sicily, and he has referred a considerable number of microfungi to various existing allied genera. He describes specimens of *Pythites*, *Peronosporites*, *Uncinulites*, *Erisiphites*, *Perisporites*, *Chatomites*, *Melanosporites*, *Microthyrites*, and *Monilites*. In the latter he gives spore-measurements.

Fungus Flora of Humus.¶—C. A. J. A. Oudemans and C. J. Koning are studying woodland soil, and by examination and culture determining the different fungi that grow there, chiefly the microscopic varieties. Their method is to take a small bit of decayed vegetation with spores or mycelium adhering to it. This is triturated in sterilised water, then diluted. A small quantity of the fluid is added to prepared gelatin and comparatively pure cultures are obtained of the different organisms. Oudemans is responsible for the determination of the species. He has already found 45, mostly Mucoraceæ and Mucedineæ, with 3 Sphærospideæ. There are four new species of *Mortierella* and 2 new species of *Mucor*. In all he finds 33 species are new to science of those that he has named. A number of bacteria have also been isolated, but they are not dealt with in detail. The paper is beautifully illustrated.

\* Op. cit., xxxii. (1902) pp. 47-55.

† Hedw. Beibl., xli. (1902) pp. 177-8.

‡ Mycological Notes, by C. G. Lloyd, No. 9 Lloyd Library (Cincinnati, April 1902).

§ D. McAlpine, Fungus Diseases of Stone Fruit Trees in Australia and their Treatment, Melbourne, 1902, 165 pp and 54 pls.

|| Atti d. Reale Accad. dei Lincei, xi. (1902) pp. 248-53.

¶ Arch. Neer. Sci. Exact. et Nat., vii. (1902) pp. 266-98 (30 pls.).

**Pests of the Flower Garden.\***—Under this title, M. C. Cooke publishes the first instalment of a survey of plant diseases. The introduction deals with the habits of growth and general appearance of parasitic fungi. He describes the parasites themselves under the natural orders of plants on which they have been found, and the present paper takes us as far as the Rosaceæ.

**Seed-Fungus of *Lolium temulentum*.†**—E. M. Freeman is of opinion that the poisonous properties of this grass are probably due to the fungus that is found in the seed. It has not been possible to cultivate the hyphæ of the fungus apart from the seed, and as the grass does not suffer from the presence of the parasite, there is probably a symbiotic relationship between the two organisms. The fungus has not been identified with any known form; it persists in an infection layer of hyphæ close to the embryo. From this layer infection of the growing point takes place, and the fungus grows with the host-plant.

***Leptothrix racemosa*.‡**—Josef Arkövy discusses the systematic position and life-phases of this fungus. He finds that it is the parent organism of very different forms.

**Fungous Diseases of White Cedar.§**—John W. Harshberger gives an account of two fungi, *Gymnosporangium biseptatum* Ellis and *G. Ellisii* Farlow, both of which attack the young stems and branches of white cedar. The author gives a historical account of the different species of *Gymnosporangium*. He then describes the appearance of the fungi and the damage they do to the tree. He gives a careful study of the life-habit of the cedar, *Cupressus thyoides*, and the formation of the tissues, showing the bearing of these conditions on the attack of the fungus. He describes the pathological changes induced by the penetration of the mycelium into the tissues; comparing the attack with those of the larch and fir diseases due to *Dasyscypha Wilkommii* and *D. resinaria*. The specimens of the fungus were collected in the bog-swamps of New Jersey where the white cedar grows. *G. biseptatum* causes elongate swellings which may surround the whole stem. *G. Ellisii* leaves the branch uninjured below the point of attack. Above the injury, the branches are stunted and form a fan-shaped witch's broom.

**Oidium Production and the Culture of the Higher Fungi.||**—Richard Falck gives some results of his work on spore cultivation. He began with the spores of *Collybia velutipes* which germinate easily and produce a mycelium which breaks up into oidia. He transferred the oidia to bread and in time reproduced the *Collybia* form. He followed the same process with equal success with the spores of *Phlebia merismoides*, the oidia in this case being transferred to branches of a cherry-tree. Various other Basidiomycetes were experimented with and cultivated through the *Oidium* stage. He notes that in a pure culture of

\* Journ. Roy. Hort. Soc., xxvii. (1902) pp. 1-45 (3 coloured pls. and 2 figs.).

† Proc. Roy. Soc., lxxi. (1902) pp. 27-30.

‡ (Est.-ung. Vierteljahrsschr. f. Zahnheilk., xviii. (1902) pp. 8-32 (1 pl.). Cf. Centralbl. Bakt., xxxii. (1902) p. 78.

§ Proc. Acad. Nat. Sci. Phil. (1902) pp. 461-502 (with pls.).

|| Beitr. z. Biol. d. Pflanz., viii. (1902) pp. 307-46 (6 pls.).

*Hypoholoma fascicularis* the mycelium had the familiar odour of woods. The author gives a particular account of the development of *Collybia tuberosa*. The *Oidium* formed a colony of oidia and from the colony was developed the sclerotium which produced the higher fruit form. From all his experiments he gathers that the *Oidium* form is a definite stage in the life-cycle of many of the higher fungi, and that under proper conditions these will again be reproduced. In the case of *Oidium lactis* this property is lost and no higher form is ever developed, though from cultivation and comparison with other forms the writer thinks that this *Oidium* should be placed near the ascomycetous fungus *Endomyces*.

**Critical Notes.\***—C. A. J. A. Oudemans passes in review a large number of species of Fungi, rectifying mistakes that he has discovered in description, quotation, or nomenclature. He has found something to correct in 37 species of published fungi.

**Sap of Fungi as an Antidote to the Venom of Serpents.†**—X. Gillot publishes an account of work carried on in this connection by C. Phisalix and others. They used sap extracted directly from the fungi or a decoction obtained by 24 hours' maceration in water. They employed several species of fungi, *Amanita muscarius*, *A. mappa*, *Lactarius torminosus*, *L. theogalus*, all poisonous species; but even with *Agaricus campestris*, an edible fungus, the animals experimented on died when a large dose was used. With smaller doses all these fungi made the animals immune to the venom of serpents. The period of immunity lasted from 15 days to a month.

**Photography of Fungi.‡**—Léon Roland gives his methods of decolorising fungi before photographing them, by which means he secures good and true representations of the plants. He also records successful results from the employment of a decoction of *Amanita mappa* and other fungi as an accelerating solution.

#### Schizophyta.

#### Schizophyceæ.

**Chemical Composition of *Oscillaria prolifica*.§**—Isabel Hyams and Ellen Richards give an analysis of dried *Oscillaria* at various stages of its growth, and also analyses of the water in which it occurred. The proportion of silica in the plant is remarkable, and with some other characteristics indicates an approach to the condition found in diatoms. This large amount of silica accounts for the remarkable stability of the framework or tissue of the plant which persists all the year round.

**New Species of *Fischerella*.||**—Maurice Gomont describes and figures a plant growing in the greenhouses of the Budapest Museum, and names it *Fischerella major*. The principal interest of this plant lies in the fact that it possesses spores, which are formed under conditions which are unfavourable to the normal growth of the alga. Their

\* Rev. Myc., xxiv. (1902) pp. 98-115.

† Op. cit., pp. 125-7.

‡ Op. cit., pp. 85-8.

§ Technol. Quarterly (Boston), xv. pp. 308-15.

|| Journ. de Bot., ix. (1902) pp. 291-300 (1 pl.).

germination and the development of the young filament resemble similar occurrences in *Stigeonema*, to which genus *Fischerella* is closely related. Comparisons are drawn between *F. major* as compared with *Stigeonema hormoides*, *Hapalosiphon intricatus*, and *H. arboreus*.

#### Schizomycetes.

**New Gum Bacterium.\***—R. Greig Smith describes a new species, *Bacterium eucalypti*, found in a sweet exudate of *Eucalyptus Stuartiana*. It forms a gum, levan, identical with those previously obtained by the author by cultivating *B. levaniformis* in saccharose media. The new species from the latter, occurs in cane-juice and raw and refined sugars; and it is interesting that the same gum should be formed by two widely differing species.

**Acid-Rennet-forming Bacteria in Milk.**—C. Gorini publishes a preliminary note on his latest researches on the normal bacterial flora of milk. The bacteria of milk are usually divided into two classes—the lactic ferments which by the production of acid coagulate the milk, but are unable to redissolve the coagulum; and the peptonising bacteria (e.g. tyrothrix), which coagulate the milk with a neutral or alkaline reaction and then redissolve the coagulum. But the author has discovered the existence of a third class of bacteria which acidulate and coagulate the milk and then redissolve the coagulum. Having first satisfied himself by laboratory experiments that this third class of bacteria is distinct from the first (which acidify, but do not produce rennet), he proceeded to examine the milk taken aseptically from a number of cows of different dairies, and found that in every case the acid-rennet-forming bacteria (the third class) were present normally and abundantly, and have the power of liquefying the coagulum in the presence of acid. He points out the importance of these bacteria in the process of cheese-making.

**Microbe of the "Loque" Disease of Bees.†**—V. Lambotte finds that the *Bacillus alvei*, described by Watson-Cheyne and Cheshire as the cause of the "loque" disease of bees, is merely a variety of the widespread *Bacillus mesentericus*. The bacillus occurs in healthy hives, being found in the comb and in the intestinal contents of the bees. The characteristic appearance of the disease is brought about by the budding of the bacillus in the tissues of the larva.

As the result of actual experiment, it is found that healthy hives may be infected by visitors from unhealthy hives, but the most prolific causes of the disease are insufficient nutrition, and want of cleanliness and proper ventilation. Since the spores of the bacillus easily withstand the action of ordinary disinfectants, the only way of stamping out the disease is to burn all infected stock.

**Compound Cilia.‡**—E. Malvož, in a short paper illustrated with two excellent photographs, gives a historical account of compound cilia in bacteria, adding the results of his own observations upon the compound

\* Proc. Linn. Soc. New South Wales, xxvii. (1902) pp. 230-6 (1 pl.).

† R. Ist. Lombardo Rendiconti, xxxiv. (1901) pp. 1279-83.

‡ Ann. Inst. Pasteur, xvi. (1902) pp. 694-704. § Op. cit., pp. 686-9.

cilia of a bacterium obtained from a typhoid patient. These compound cilia take the form of relatively immense fusiform spirals surrounding a central substance, the nature of which was not determined. Malvoz supports the view of Migula that these cilia are really compound, and not merely a single cilium of colossal proportions. The mode of formation of the spirals is uncertain, but, in all probability, two bacteria become attached by their cilia, one of the latter becoming separated from its bacterium. The frequent repetition of this process finally results in the formation of the complex spirals, which, breaking away from the bacterium, ultimately lie free in the surrounding liquid.

**Use of Neutral Red in the Study of Phagocytosis, &c.\*** — The value of neutral red as a reagent depends upon its property of staining living cells. J. Himmel finds that the stain is taken up by all substances engulfed in the living leucocyte, and also by the granules resulting from the metabolism of the cell. The staining action depends upon the oxidising properties of the cell, and it is also shown that all factors affecting the vitality of the cell have a corresponding action upon the efficiency of the stain.

✓ **Identification of some Anaerobic Bacteria.†** — P. Achalme concludes that form and relative mobility are useless as criteria for the identification of species. Staining, however, especially by the Claudius method, is of considerable value in the discrimination of different groups of species, but is of little value for the distinction of the species themselves. Again, the appearances presented by cultures upon solid media are of no value, as the appearances depend upon the nature, and especially the consistency of, the medium. The mode of spore-formation is more satisfactory, but is by no means sufficient. Achalme expected to obtain the most reliable results from observations upon the differences, if any, existing between the assimilatory functions of the forms studied, and his expectations were fully realised. He experimented upon nitrogenous and carbohydrate media, the points considered being (1) the means employed by the microbe for the utilisation of the food-substance, (2) the chemical nature of this substance, (3) the nature of the chemical changes brought about in the medium by the organism. Studying more especially (1) the action of the bacteria upon albumen in the presence of different carbohydrates, and (2) the influence of the latter upon the relative abundance of the cultures, Achalme was enabled to construct a dichotomous key for the identification of the species considered, the criteria being as indicated.

**Agglutination.‡** — Nicolle and Trenal find that the agglutinative and agglutinogenous functions are subject to the greatest variations, and conclude that the functions can be referred to the enveloping membrane of the microbe. This is supported by the fact that the phenomena are much more obvious in those bacteria with the membrane well developed than in those in which the membrane is not so obvious. The authors come to the same conclusion in regard to the free cells of the organism.

\* Ann. Inst. Pasteur, xvi. (1902) pp. 663-85.

† Op. cit., pp. 641-61.

‡ Op. cit., pp. 562-86.



**Structure of Bacteria.\***—F. Schaudinn describes his observations on the structure of a new bacillus, the *B. Butschli*, which he isolated from the midgut of the large kitchen beetle (*Periplaneta orientalis*). His observations were chiefly directed to the structure of the organism, its method of spore-formation, and of spore-germination. The bacillus occurs as a long cylindrical rod with rounded ends, about 50 to 60  $\mu$  in length (maximum noted 80  $\mu$ ). The cell is enclosed in a somewhat dense membrane, which does not give a cellulose reaction. The finely granular cell protoplasm contains numerous coarser granules in its substance which form the nodal points of a distinct network, the whole giving an appearance of an alveolar system. Morphological differentiation of a nucleus was not observed, but the author considers that the nodal points of the network, scattered throughout the cell-protoplasm, correspond to the aggregation which in the higher organisms receives the name of nucleus. The vegetative reproduction of the organism is preceded by the collection of several of these coarse granules to the opposite poles of a bacillus; these shortly become more highly refractile and stain intensely. This stage is followed by the appearance of a septum at right angles to the long axis of the bacillus, which, commencing in the centre, soon spreads to the enclosing membrane and separates into two lamellæ; finally division takes place at the site of this septum. Spore-formation is characteristic, in that two spores are formed in each bacillus; the preliminary stages of aggregation of granules to the poles and the appearance of a central septum occur as a vegetative reproduction. At this point, however, the septum becomes resolved and finally disappears, leaving no trace of its presence behind. The protoplasm round the polar granules becomes condensed and forms the spore-capsule, and the perfect spores are now oval or ellipsoid in shape. The author is of opinion that the appearance and subsequent disappearance of the septum is an indication of a process analogous to the conjugation of the reproductive cells of higher organisms. Spore-formation only takes place in beetles which are overfed, but may be produced artificially by inoculating in a mixture of intestinal secretion and saliva. In the actual process of germination, the young bacillus grows out through one of the poles of the ellipsoid, elongates, and takes on the characteristic form of the bacillus, almost immediately showing the distinctive alveolar arrangement of the protoplasm.

**Psychrophilic Bacteria.†**—S. Schmidt-Nielsen has studied numerous bacteria with respect to their capacity for growth at 0° C. He finds that the *B. aquatilis fluorescens non-liquefaciens* grows well in 10 days; the *B. granulorum* in 40 days; *B. paracoli gaso-formans* feebly in 40 days; *B. radiatum* feebly in 10 days, but more vigorously in 40 days; and the *B. tardi fluorescens* feebly in 40 days. From earth and from vegetables the author isolated 15 other varieties (which on account of an accident he was unable to identify) which possess a similar capacity. So also two unnamed saccharomyces, and a pink torula isolated from the shell of a deep-water shrimp, are capable of multiplying at 0° C. Three

\* Centralbl. Bakt., 1<sup>o</sup> Abt. (Ref.), xxxii. (1902) pp. 139–40. See also Archiv. f. Protistenkunde, I. (1902) pp. 306–43.

† Centralbl. Bakt., 2<sup>o</sup> Abt., ix. (1902) pp. 145–7.

varieties of actinomyces, viz. *ochraceus*, *ochroleucus*, and *carneus*, show evidence of multiplication at 0° C. after 80 days. The author found that numerous bacteria (including the *B. coli communis* and the *B. enteritidis* of Gärtner), although unable to grow at the temperature, were not killed by a 60 days' exposure to it, as when transferred to the incubator at 24° C. growth took place.

**Action of Alcoholic Fermentation on the Bacillus typhosus.\***—E. Bodin and F. Pailheret, having in a previous communication proved that it could multiply in acid cider, made a series of experiments to determine whether the *B. typhi abdominalis*, if previously existing in must, could withstand the action of alcoholic fermentation. They therefore prepared artificial must, consisting of neutral solutions containing 0·5 to 1·5 p.c. peptone, and 3 to 5·5 p.c. pure glucose, ordinary sugar or candied sugar, and planted the *B. typhi* therein. The bacillus growing well, the solution was then inoculated with (? pressed) yeast, and kept at 22° C. Vigorous alcoholic fermentation then ensued, and the authors found that the *B. typhi* and also the *B. coli communis* remained living throughout and after the process. Further, in saccharose media the authors found that the *B. typhi* would only remain alive if carbonate of lime had first been added to the medium (to neutralise, as soon as found, the acid products of the growth of the bacillus), whilst the *B. coli* persisted under all conditions.

**Identity of Rhinoscleroma Bacillus with Friedländer's Bacillus.†**—Felix Klemperer and Max Scheier contend that the bacillus of ozæna and of rhinoscleroma are identical with Friedländer's bacillus, basing their contention on the morphological resemblances and the similarity of the cultural reactions. They further state, as the result of their own experiments, that specific antitoxin and agglutinin are formed in animals immunised against these bacilli; and that serum obtained from animals immunised against each of these organisms will cause "clumping" of all three species, but is so far specific in its action that it fails to clump cultivations of other bacteria. They therefore conclude that the use of the titles bacillus of ozæna and bacillus of rhinoscleroma should be discontinued, and the organisms in question referred to as Friedländer's bacillus in ozæna or in rhinoscleroma respectively.

**Differentiation of Bacillus typhi abdominalis and Bacillus coli communis.‡**—F. Krause describes a method of differentiating the *B. typhi* from the *B. coli* by means of the study of the deep colonies grown in a urine medium containing 1 p.c. agar and 15 p.c. gelatin for from 14 to 15 hours at 37° C. (at which temperature the medium remains solid and is only very slowly liquefied by peptonising bacteria). The author states that the reaction of the medium is extremely important and should correspond to 0·3 p.c. lactic acid. Under these conditions the typhoid colonies are rounded or sometimes irregular in shape, varying in size, and finely granular and greyish in colour, becoming slightly brownish as the colony enlarges. From these colonies

\* Comptes Rendus, cxxxv. (1902) pp. 299-301.

† Centralbl. Bakt., 1<sup>o</sup> Abt. (Ref.), xxxii. (1902) pp. 70-1. See also Zeitschr. f. Klin. Med., xlv. (1902) pp. 132-51.

‡ Centralbl. Bakt., 1<sup>o</sup> Abt. (Ref.), xxxii. (1902) pp. 337-8. See also Archiv. f. Hyg., xlv. H. 1.

radiate numerous very slender, straight or curved, sometimes long spiral offshoots.

Coli colonies, on the other hand, are dark yellow-brown in colour, very variable in size, round or irregular, and coarsely granular; around each colony may be seen one or more concentric zones, as if of ground glass, in which situation daughter colonies frequently develop.

*B. dysentericæ* and a slowly liquefying bacillus (unnamed) give rise to colonies indistinguishable from those of the *B. typhosus*, but none other of the organisms studied by Krause could possibly give rise to confusion.

**Bacterium Fragi.**\*—W. Eichholz describes a new bacillus which he isolated from a sample of milk, to which it had given a distinct strawberry smell.

The organism in question was a long motile bacillus,  $1.75$  to  $2.10 \mu$  long by  $1.05 \mu$  broad, possessing a tuft of flagella at one pole. Upon lactose-gelatin plates the organism forms characteristic small, whitish, rosette-shaped colonies, with a coarsely granular mass of concentric circles, the periphery around this central mass being thin, flat, spreading, and marked with radiating lines, the colony thus resembling the flower of the daisy. The organism does not form spores, and its optimum temperature lies between  $26^\circ$  and  $29^\circ$  C., its range being from  $1.5^\circ$  C. to  $37^\circ$  C., and its thermal death-point is about  $75^\circ$  C. When grown in milk there is neither gas-formation nor clotting, but after three days at the room temperature the milk possesses a rotten smell; by about the eighth day this has given place to a distinct odour of strawberries, which lasts for a considerable period, the milk undergoing no further change.

**Bacillus aerogenes aerophilus agilis.**†—A. Uffenheimer describes a new gas-forming bacillus to which he has given the name *B. aerogenes aerophilus agilis* sp.n., isolated from the liver, spleen, and blood, as well as from the placental site, in a case of general infection and death following abortion.

The bacillus occurs as thick rods, about the same size as the anthrax bacillus, with rounded ends; it stains easily and is not decolorised when treated by Gram's method. The colonies on agar plates were not characteristic; they were whitish-grey in colour and generally round. In agar-stab cultivations growth occurs, and along the line of puncture numerous gas bubbles are formed. In gelatin plates the colonies were quite small and translucent, and later became turbid greyish-white in colour. In sugar media copious gas formation occurs, and in broth general turbidity. Milk is coagulated at  $37^\circ$  C. Anaerobic cultures by Buchner's method yielded only a very scanty growth.

The vitality of the bacillus is short: Inoculation experiments were made upon white mice, guinea-pigs, and rabbits, subcutaneously and intraperitoneally, and in the case of one rabbit, intravenously. Several of the animals showed no reaction whatever; one of the guinea-pigs, which was bled copiously a week after the injection, died four days later. After death the body was placed in the incubator, and after 24 hours

\* Centralbl. Bakt., 2<sup>o</sup> Abt. (1902) pp. 425-8.

† Op. cit., 1<sup>o</sup> Abt. (Ref.), xxxi. (1902) pp. 533-5. See also Beitr. z. Path. Anat. u. Allgem. Pathol., xxxi. (1902).

became enormously distended with gas, and the bacillus in question was recovered from the blood and all the organs in pure cultivation.

**Bacillus aerogenes capsulatus in Circulating Blood.\***—R. Cole obtained the *B. aerogenes capsulatus* Welch from the blood of the general circulation of the living patient, both of whose lower limbs had been amputated after a severe crush. The method employed was to withdraw 8 c.cm. of blood from a superficial vein at the bend of the left elbow by means of a sterile syringe, and distributing 7 c.cm. among 12 tubes of litmus milk and incubating anaerobically in a Novy's jar. The remaining cubic centimetre was injected intravenously into a rabbit, which was killed after a few minutes and placed in the incubator at 37° C. for 24 hours. At the end of this time the animal was distended with gas and subcutaneous emphysema was present. From the heart-blood of the rabbit and from the liver and spleen the *B. aerogenes capsulatus* was isolated in pure cultivation; the litmus tubes also gave a pure cultivation. Some 25 c.cm. of blood were conducted from the arm of the patient (before death) by means of a rubber tube into a basin of water, and the author was able to show that no free gas was present in the circulating blood.

**Bacillus vascularum and gummosis.†**—R. Greig-Smith describes a new bacillus isolated from the gummy exudation of the vascular bundles of sugar-canes affected with gummosis. The organism is an obligate aerobe growing best at 30° C., and not at all at 37° C., averaging 0.4 to 1  $\mu$  in length, actively motile, and possessing a single terminal flagellum. On glucose-gelatin plates the colonies develop slowly as small, raised, viscid, granular drops, which in about 20 days reach a diameter of 4 to 8 mm., and resemble drops of yellow beeswax; the medium is slowly liquefied. Gelatin-stab shows a filiform growth in the upper part of the puncture, with a hemispherical, yellow, glistening nail-head; no gas-formation occurs. Glycerin-agar gives a thin, broad, translucent, white, moist, glistening growth, which later deepens to a primrose-yellow, with turbid condensation-water. Milk is unaltered in appearance. Nutrient broth shows a scanty growth, uniformly turbid, and gives a faint indol reaction. The best medium consists of peptone 0.5 p.c., saccharose or levulose 5 p.c., potassium phosphate 0.5 p.c., agar 2 p.c., in tap-water, with its reaction adjusted to correspond to 10 c.cm. = 0.14 c.cm. N/10 acid. The organism upon this medium grew well, and produced a slimy material identical in appearance, and by chemical tests, with the gum obtained from the diseased plants, thus confirming the assumption of Cobb, and at the same time completely disproving the statement of Mangin that the gum was produced by the sugar-cane, and that the bacteria lived upon it.

**New Ascobacterium from the Sugar-Cane.‡**—R. Greig-Smith gives an account of a new organism, *Bacterium sacchari*, which he found existing as a normal saprophyte of the sugar-cane, and which formed well-defined masses of capsulated bacteria, under certain conditions, when grown upon solid media in the presence of a sugar. The solid

\* Bull. Johns Hopkins Hosp., xiii. (1902) pp. 234-5.

† Proc. Linn. Soc. New South Wales, xxvii. (1902) pp. 30-47.

‡ Tom. cit., pp. 137-44.

medium most favourable to the production of this phenomenon was prepared by dissolving 10 p.c. of gelatin in cane-juice, and rendering the medium neutral to phenolphthalein by the addition of dilute potassium hydrate.

The organism is a short motile rod, 1 to 2  $\mu$  long, with a variable number of flagella, from a single terminal one to nine arranged around the bacillus. It is an obligate aerobe, and does not form spores; it stains feebly with methylen-blue, but well with fuchsin and violet, and is decolorised by Gram's method. Its optimum temperature is 28° C. On gelatin it forms raised, rounded, glistening, white colonies, with a dark, granular, areolate centre and crenate margin. In broth the medium becomes turbid, and pellicle-formation occurs; traces of indol are sometimes found. Milk is coagulated in about 10 days, with faintly acid reaction. On potato the growth is thin, flat, and dry, glistening, and of a deep yellow colour.

**Bacteria of the Milk-ducts of the Cow.\***—C. Gorini examined milk collected (with all possible attention to asepsis) from 14 cows belonging to the Berne Institute, 6 from an outside dairy, and 2 from a third source. He found that no one udder was completely sterile, the number of bacteria observed per cubic centimetre from each teat varying from a minimum of 20 to a maximum of 300,000. The bacterial flora of the teats consisted chiefly, and sometimes exclusively, of cocci, which were similar in morphology. By their action upon gelatin and milk, however, the author is able to distinguish five types, three of which liquefy gelatin and coagulate milk, though at different rates of time; the remaining two types coagulate milk, but do not liquefy gelatin. He therefore concludes that these cocci represent the normal bacterial flora of the galactiferous ducts of the cow, and that the *B. acidi lactici* does not exist as a normal saprophyte in this situation. In milk from 6 cows from an outside dairy streptococci were found.

**Bacteriology of Natural Mineral Waters.†**—G. v. Rigler, as the result of numerous chemical and bacteriological examinations of German and Austro-Hungarian natural mineral waters, states that they are but very rarely germ-free, and that further contamination takes place in the process of bottling. The chief varieties of bacteria he has isolated from these waters, arranged in order of frequency, are *B. fluorescens liquefaciens*, *B. fluorescens non-liquefaciens*, *B. aquatilis odorans*, *B. chryso-glæa*, *B. aquatilis communis*, *B. arborescens non-liquefaciens*, *B. gaso-formes non-liquefaciens*, *Micrococcus candicans*, *M. sulphureus*, *M. roseus*, and *Actinomyces alba*.

**Bacillus of Soft Sore.‡**—F. Besançon, V. Griffon, and Le Sourd, using a gelatin medium containing rabbits' blood, were able to obtain a bacillus from primary soft sores, and also from the pus of buboes. The bacillus occurs microscopically as slender rods, singly, in groups of parallel individuals, or in chains placed end to end. It exhibits polar staining, and retains the stain when treated by Gram's method. When

\* Atti Reale Accad. d. Lincei, xi. (1902) pp. 159-65.

† Centralbl. Bakt. (Ref.), 1<sup>o</sup> Abt., xxxi. (1902) pp. 681-2. See also Hyg. Rundschau, xii. (1902) p. 473.

‡ Centralbl. Bakt. (Ref.), 1<sup>o</sup> Abt., xxxi. (1902) p. 122. See also Gaz. des Hôpitaux, 1900, No. 141.

grown 48 hours at 37° C. the bacillus forms small, round, raised, isolated colonies of about 1 mm. diameter, opaque, and greyish in colour, with a glazed, shiny surface. In subcultures the organism grows more luxuriantly. It retains its vitality and virulence a considerable time, but in the condensation-water, where it forms long chains, it does not remain living very long. The only other medium in which it will grow is fluid serum from rabbits' blood, in which it forms turbid flocculi. The authors succeeded in three cases in producing typical soft sores by inoculating the surface of the peritoneum with isolated colonies of the bacillus.

**Gonococcus in the General Circulation.\***—W. B. Johnson records a case of endocarditis and general septicæmia due to the presence of the gonococcus, in which he was able to demonstrate the presence of the specific organism in the circulating blood.

Cultivations were made from the circulating blood on five separate days; at the fifth attempt, 24 hours before death, pure growths of the gonococcus were obtained, and the author points out that it is neither necessary to use a large amount of blood to obtain cultivations from these cases, nor to greatly dilute the blood with the medium used, nor to employ any specially prepared medium, for the bactericidal power of the blood appears to have but very slight effect in retarding the growth of the gonococcus. Moreover, he found that it was more advantageous to mix the blood with melted agar and at once pour plates, than to use fluid media, where the oxygen supply is more restricted.

**Agriculture and Bacteria.†**—H. W. Wiley states that the nitrogen necessary for the nutrition of plants and crops is derived from organic compounds previously broken up by the bacteria present in the soil. In this process three stages are distinguishable, each being identified with a specific species of organism. First, the organic matter is broken up into ammonia or its compounds by the activity of the *B. mycoides*; next, the ammonia is converted into nitrous acid or its compounds by the nitrous bacteria, of which, so far, only one species has been isolated, the *nitroso-monas*; and finally, the nitrous acid is converted into nitric acid or its compounds by the *nitro-bacteria*; both these last bacteria were originally isolated by Winogradsky. A second type of nitrification, in which the atmospheric nitrogen is utilised, is effected by parasitic organisms existing in the tubercle on the roots of certain Leguminosæ. Cultures of these organisms are prepared commercially and sold under the name *nitragin*. Another species (the Alinite bacteria), stated to possess similar properties, is likewise prepared commercially.

#### Mycetozoa.

**Culture of Myxomycetes.‡**—Pinoy gives the results of his attempts to make pure cultures of *Chondrioderma difforme* and *Didymium effusum*. He finds that they can be grown, if a bacterium be cultivated along with them. This *Bacillus* he determines to be identical with *B. luteus* of Flügge.

\* Bull. Johns Hopkins Hosp., xiii. (1902) pp. 236-41.

† Journ. Franklin Inst., cliv. (1902) pp. 81-91 and 161-9 (1 pl.).

‡ Bull. Soc. Myc., xviii. (1902) pp. 288-90.

## MICROSCOPY.

## A. Instruments, Accessories, &amp;c.\*

## (1) Stands.

**New Binocular Microscope.**†—F. E. Ives, after an enumeration of the inconveniences which render the ordinary binocular unsuited for high-power work, describes one of his own invention, which has the following advantages:—(1) It is a short-tube Microscope; (2) The parts which make it a binocular may be attached without alteration; (3) It is not an expensive attachment; (4) It does not interfere with the use of the Microscope as a monocular with variable tube-length; (5) It may be used either as a binocular non-stereoscopic Microscope, or as a binocular stereoscopic Microscope; (6) As a non-stereoscopic binocular, it sends to both eyes images practically identical with the single image of a monocular, no diffraction pencils being cut off from either image, and it is as satisfactory with the highest as with the lowest powers, dividing the work evenly between the two eyes even when doing the most critical work; (7) As a stereoscopic binocular, it yields to both eyes images distinctly more perfect than either image in a Wenham binocular, and, while giving true stereoscopic relief with medium and low powers, never exaggerates this effect, as the Wenham binocular sometimes does. As against these advantages may be placed the fact that it requires a little more skill to adjust it than the Wenham binocular; but it should not be at all troublesome to the

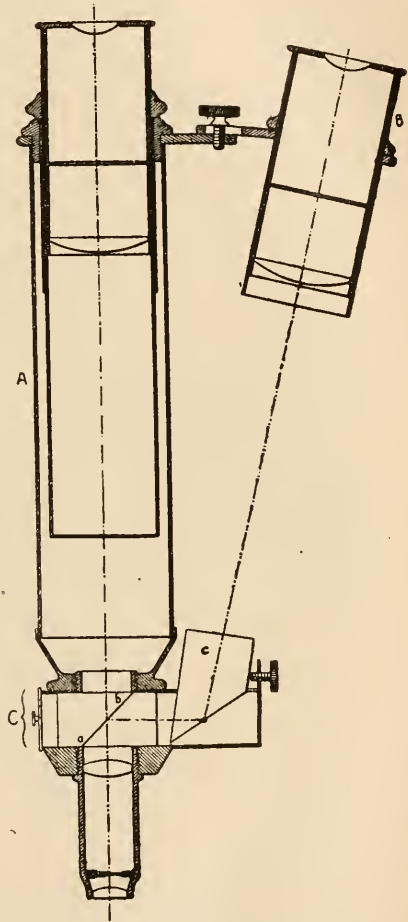

FIG. 3.

\* This subdivision contains (1) Stands; (2) Eye-pieces and Objectives; (3) Illuminating and other Apparatus; (4) Photomicrography; (5) Microscopical Optics and Manipulation; (6) Miscellaneous.

† Journ. Franklin Inst., cliv. (1902) pp. 441-5 (1 fig.).

expert microscopist. In fig. 3 are shown the two attachments which effect this change in an ordinary Microscope:—(1) a small prism-box with Society screw to fit the lower end of the Microscope-tube; and (2) an attachment to the upper end of the tube to carry the second eye-piece, with means for adjustment to suit different pupillary distances. The prism-box C contains one compound cemented prism, with transparent silvering on one of the inner faces *a b*, and a single prism *c*. The dotted lines show the path of the axial ray, one half of which is transmitted through the compound prism, and the other half reflected into the prism *c*, and thence to the auxiliary eye-piece. The body of the prism *c* is extended in the direction of the eye-piece for the purpose of making the optical length of both axial rays alike, so that matched eye-pieces may be used. There are three ways of changing from binocular non-stereoscopic to stereoscopic vision. The first consists in covering a portion of the top of the compound prism by a little metal slide. The other two methods depend upon the fact that de-centring the eye-points is equivalent to covering opposite sides of the back of the objective. Hence, if the eye-points are brought about one-eighth of an inch closer together than the observer's pupillary distance, stereoscopic vision is secured; if they are separated by such an amount, then pseudoscopic vision results. With low-power objectives and two-inch eye-pieces one may arrange the distance so that, by slightly varying the plane of the eye-points, one may have stereoscopic, non-stereoscopic, or pseudoscopic vision at pleasure, and without moving the eyes far enough to lose any of the field of view. With high-power objectives, the entire field is seen perfectly only when the instrument is adjusted for non-stereoscopic vision with the eyes in the plane of the eye-points.

**Watson and Sons' Metallurgical Microscope.\***—This Microscope (fig. 4) has been constructed exclusively for the examination of metals and minerals, and is of the best quality throughout. The coarse and fine adjustments do not present any novelty. The body is of large diameter, and the draw-tube can be arranged to carry either the Continental or large-sized (1·27-in.) eye-pieces, as may be preferred. When the draw-tube is closed the body-length is 152 mm.; when extended, 250 mm. The stage has mechanical screws, and in this respect resembles the "H" Edinburgh Students' Microscope, made by the same firm. In the centre of the stage is a cylindrical fitting, into which super-stage plates may be fitted and interchanged. The illustration shows a super-stage plate, with levelling-screws for the purpose of adjusting the planes of specimens under examination, so as to get them perpendicular to the optical axis. The upper surface of this super-stage is higher than the milled heads controlling the mechanical movements, so that large blocks of metal can be freely moved on the stage. The top-plate measures  $3\frac{1}{2}$  by  $2\frac{1}{2}$  in., and can be readily removed and replaced by a metal-holder, in which blocks of metal can be held at any angle, or rotated. A rackwork of strong, though very smooth and precise construction, is fitted to the stage, and permits it to be moved up and down for focussing after the lighting adjustment has been made. A vertical illuminator, with disc of cover-glass, is provided with the

\* W. Watson & Sons' Catalogue, 1902-3, p. 78.



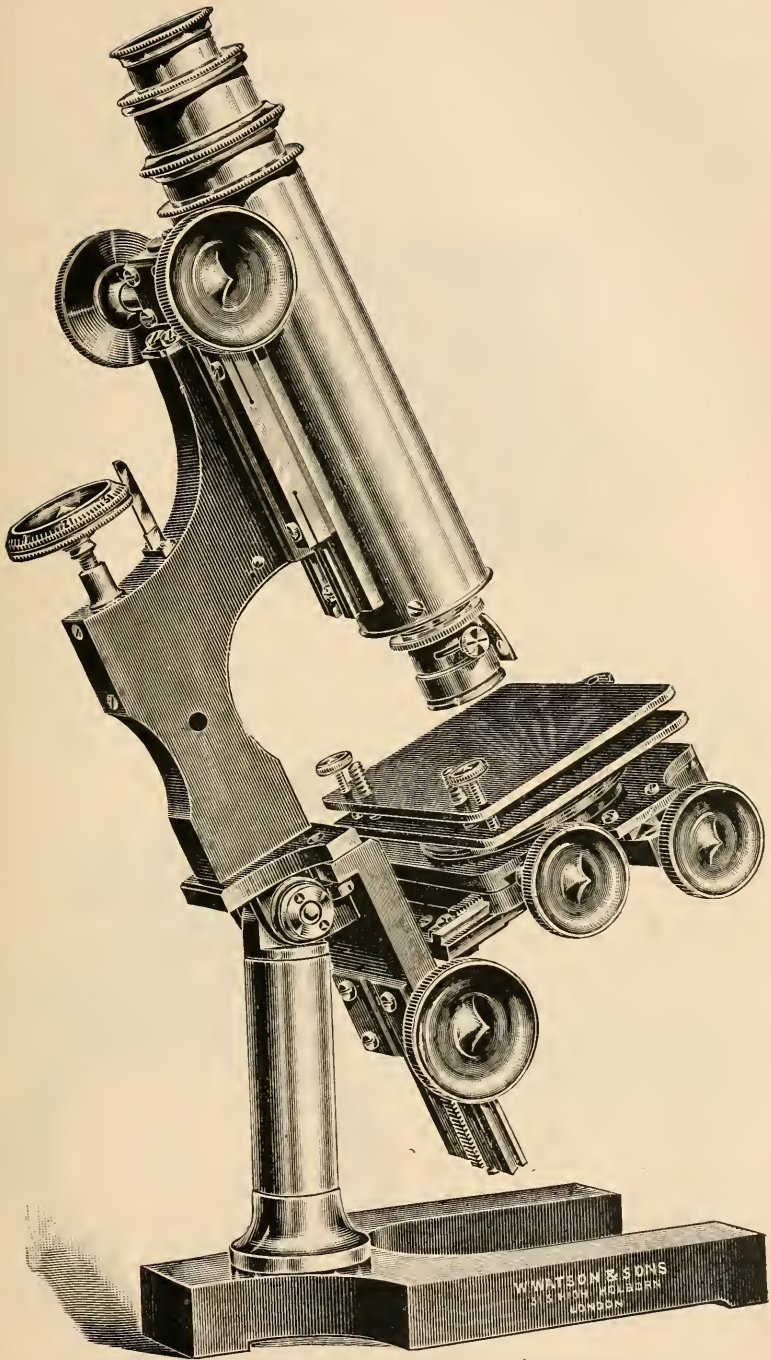

FIG. 1.

instrument, and may be fitted either at the top of the body-tube, or at the lower end, as figured.

**Watson and Sons' Museum Microscope.\***—This instrument (fig. 5) has been designed especially for the use of students who may be pursuing some particular branch of study, or for visitors to museums. It

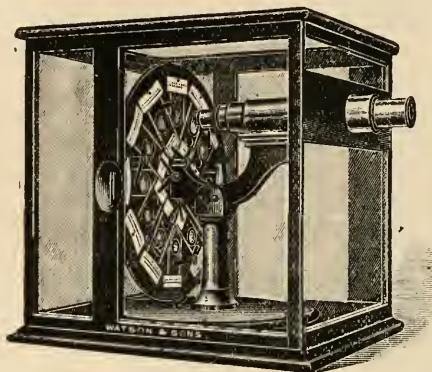

FIG. 5.

consists of a dust-proof mahogany-framed glass case, in which the Microscope is fitted. The objects, 12 in number, are mounted upon a disc, which can be rotated from outside the case. The eye-piece of the Microscope also projects outside the case, and focussing is effected by means of a milled head, actuating a rackwork-and-pinion on the right-hand side of the case.

**Method of Fitting the Stage and Limb of Watson's Van Heurck Microscope.†**—In this instrument the contrivance (fig. 6) for connecting the limb, stage, and substage is especially calculated to ensure rigidity of the whole Microscope. The limb A is fitted into the sub-stage bracket-plate D, which is held firmly by screws; the joint-bolt B goes through the whole—limb and stage-bracket—rendering the limb, stage, and substage as firm as if they were one piece. This stage-bracket C C, instead of being screwed to the front of the limb, as is usually done, is made in a solid casting; it takes the substage beneath on the plate D, and goes right *into* the joint at the top of the pillar. The

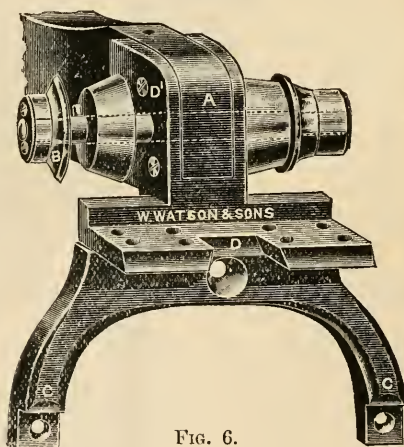

FIG. 6.

\* W. Watson &amp; Sons' Catalogue, 1902-3, p. 77.

† Tom. cit., p. 61.

makers consider that the strength and freedom from spring obtained by these arrangements are unique in Microscope construction, and that the method is altogether superior to that of connecting the parts solely by screws.

**Watson and Sons' Attachable Mechanical Stage.\***—The special feature of this stage (fig. 7) is that it can be immediately fixed to a Microscope without any special fitting. It is placed upon the stage, and grips upon the edges like an ordinary sliding-bar; it is then clamped in position by means of a thumb-screw. It has a long range of movement in both horizontal and vertical directions.

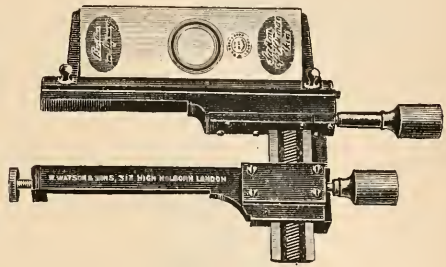

FIG. 7.

**Portable Class-Microscope.†**

This Microscope (fig. 8) is intended for the use of classes studying botany, zoology, &c.

It is of German make, and though not of recent date, has points of interest. The body slides in an outer tube, which has an expanded foot containing a Lieberkuhn  $2\frac{1}{2}$  in. diameter, and an arrangement for holding a slide in front of it. The object is viewed by holding the instrument towards the light. The objective is separable into three parts, forming powers with magnifications of 44, 96, and 130 diameters. In order to focus an object, the screw-collar on the outer tube is

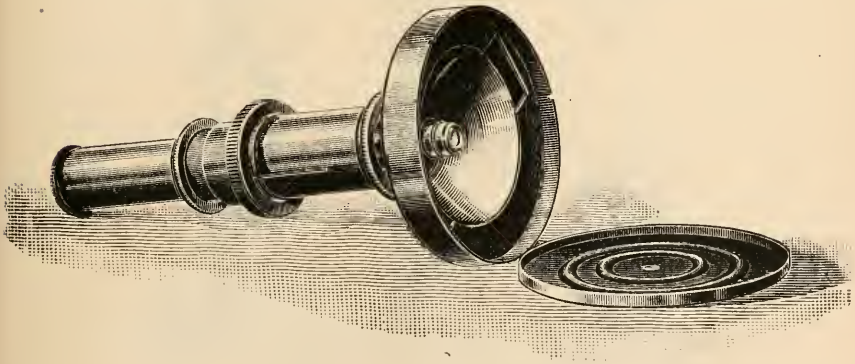

FIG. 8.

slackened, and when the focus is obtained, the collar is tightened. A cap with a small hole in the centre is provided for the protection of the Lieberkuhn, and when more than one lens is used the cap is employed, and acts as a diaphragm when transparent objects are examined.

\* W. Watson & Sons' Catalogue, 1902-3, p. 81.

† Exhibited at the October Meeting, 1902. See this Journal, 1902, p. 622.

**Barbour's Pocket Microscope.\***—This is also primarily intended for field geologists, and is small enough to be carried in the vest pocket, the entire size being scarcely larger than an objective-case. A, fig. 9, shows the instrument open; B, shut. C is a lens-case for comparison as to size. The following magnifications are obtained, viz. 100, 60, 40, 30, 20, and 15 diameters, which are amply sufficient for field work.

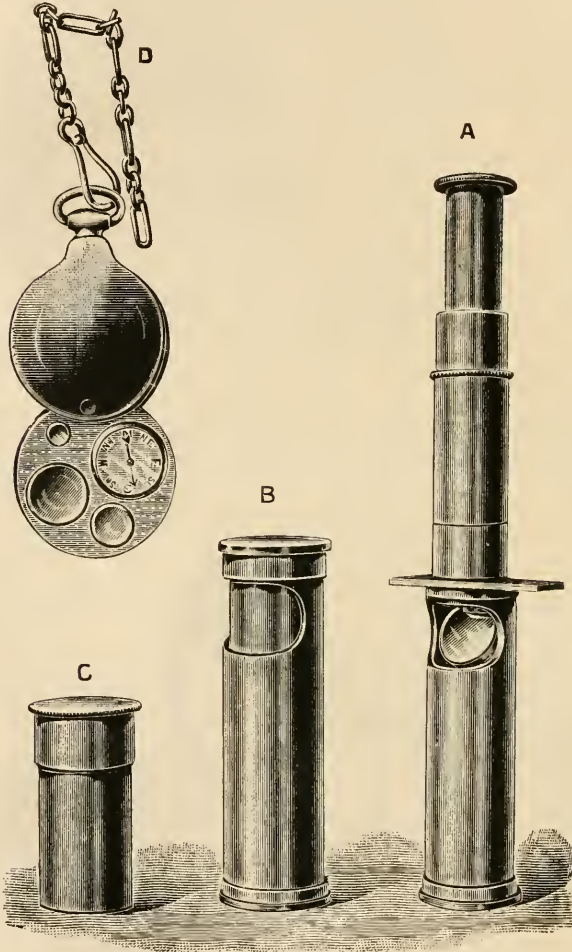

FIG. 9.

RÉGAUD, CL., ET NACHET, A.—Une nouvelle monture de microscope munie d'une platine mobile repérable à mouvements très étendus.

*Arch. d'Anat. Microsc.*, V., fasc. 1 (1902) p. 17.

RÉGAUD, CL.—Nouveau microscope pour l'étude des coupes en séries.

*Comptes Rend. Assoc. des Anatomistes*, 3, Lyon, 1901, p. 262.

\* *Journ. App. Micr.*, v. (1902) pp. 1963-5 (1 fig.).

- SCHAEFFER, W.—*Das Mikroskop, seine Optik, Geschichte und Anwendung.*  
Leipzig (Teubner), 8vo, 114 pp. and 66 figs.
- THON.—*Ein neues Trichinenmikroskop.*  
*Deutsche Thierärztl. Wochenschr.*, 1902, No. 8, p. 74.
- WOLFFHÜGEL, K.—*Ein neues Trichinenmikroskop.*  
*Zeit. f. Fleisch- u. Milchhyg.*, 1901-2, H. 3, p. 78.

(2) Eye-pieces and Objectives.

**Barbour's Pocket Magnifier.\***—This little instrument (D, fig. 9) is primarily intended for the field geologist, and is made by Messrs. Bausch and Lomb. The inventor's idea was to design a pocket magnifier which should fit in the vest pocket like a small flat watch, free from angles and corners. It contains Hastings, triplets of 5, 10, and 20 diameters, together with a compass. If desired, the compass could be omitted, and the size thereby reduced.

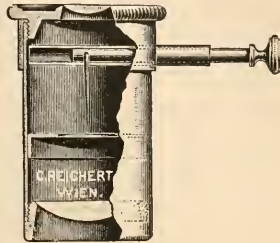

! FIG. 10.

**Bourguet's New Index Ocular.†**—This ocular (fig. 10) contains a pointer, adjustable from outside, by means of whose point every spot of the field of view can be indicated. It is especially adapted for giving students of histological and bacteriological classes definite information about any part of the microscopic field.‡

**Französische Mikroskope.**

[An account of progress recently made by French opticians in the manufacture of objectives.]

*Central. Ztg. f. Opt. u. Mech.*, XXIII. (May 1902) p. 98.

HARTWICH, C.—*Ueber ein paar Mikroskopoculare mit Messvorrichtung.*  
*Centralztg. f. Opt. u. Mech.*, XXIII. (1902) p. 11.

MALASSEZ, L.—*Sur les oculaires à glace micrométrique et à usages multiples.*  
*Arch. d'Anat. Microsc.*, IV., fasc. 2, 3 (1901) p. 219.

MCGREGOR-ROBERTSON, J.—*Ehrlich's Eye-piece for the Differential Count of Red and White Corpuscles in Stained Films.*  
*Glasgow Med. Journ.*, LV. (1901), No. 5, p. 339.

SCHAFFNER, J. H.—*Oculars for General Laboratory Work.*  
*Journ. App. Micr.*, V. (1902) p. 1646.

(3) Illuminating and other Apparatus.

**Watson and Sons' Macro-Illuminator.§**—This is a single achromatic combination of  $1\frac{1}{4}$  in. clear aperture and 2 in. focus. It excels in producing a brilliant and uniform illumination of large objects under low powers. The lens is mounted to fit into the substage, close to the object, so as to focus the image of the source of light on the objective. Objects up to fully 1 in. in diameter may be thus illuminated with absolute uniformity. It is extremely valuable for photography with the holostigmat and planar types of lenses.

\* Loc. cit.

† *Zeitschr. angew. Mikr.*, viii. (1902) p. 33 (1 fig.).

‡ This ocular is a reinvention of Quekett's indicator eye-piece (1848).

§ W. Watson & Sons' Catalogue. 1902-3, p. 99.

**Watson and Sons' Incandescent Gas Lamp.\***—This lamp is shown in fig. 11. It has an incandescent burner, with by-pass, mica chimney, and metal hood. An iris diaphragm may be fitted in the hood, so that the diaphragm aperture may be used as the light-source, and the mantle structure eliminated.

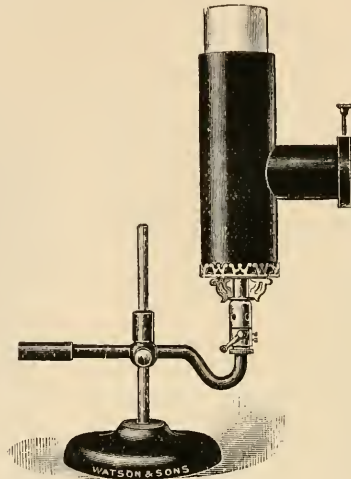

FIG. 11.

**Dr. G. Johnstone Stoney's Improved Heliostat.†**—Messrs. Watson have constructed this instrument (fig. 12) under the designer's super-

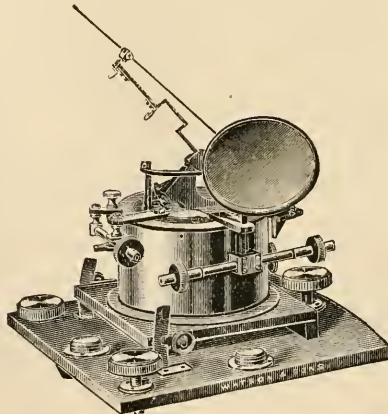

FIG. 12

vision, and the improvements effected in it render it more than ever suited to the requirements of the physicist and photomicrographer. It

\* W. Watson & Sons' Catalogue, 1902-3, p. 116.

† Tom. cit., p. 106.

is mounted on a stout mahogany base, provided with levelling-screws and spirit-levels. The lever clockwork movement is of first-rate quality, and a fine adjustment for precisely setting the position of the instrument is afforded by a rackwork-and-pinion and tangent-screw. The mirror is parallel-worked, of fine quality.

**Method of Using Abbe's Apertometer.\*** — F. J. Cheshire points out that the method of using Abbe's apertometer with a lamp-edge, as given by Dallinger,† is open to an error if the lamp is put too near, and if it be assumed that the centre  $o'$  (fig. 13) of the focussing disc is also

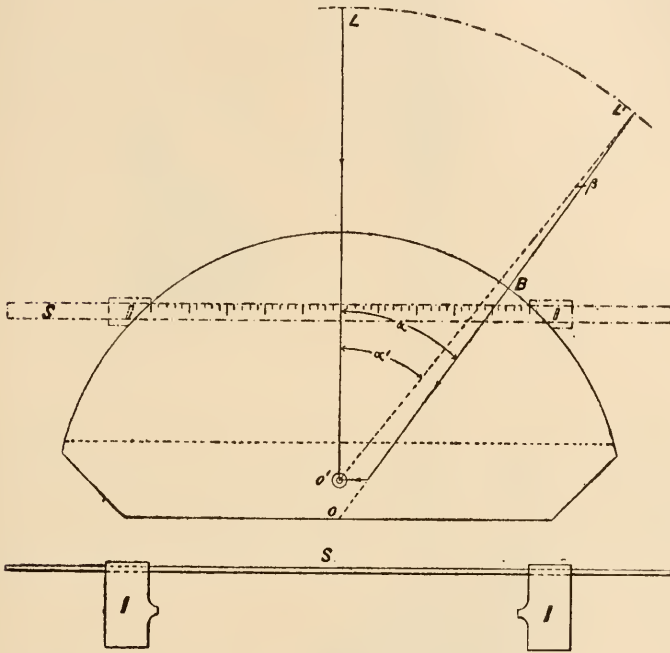

FIG. 13.

the centre of the circular edge of the apertometer; in reality this latter point is  $o$ , the middle of the chord. Let this distance  $oo'$  be  $d$ , and the distance from  $o'$  to the lamp  $L$  be  $D$ . Describe a circle with  $o'$  as centre, and  $o'L$  as radius. Suppose the adjustments made so that  $\alpha'$  is the semi-angle as usually taken,  $\alpha$  the true semi-angle, so that  $\alpha = \alpha' +$  a small angle  $\beta$ . Then it can be shown that the numerical aperture (as found) = true numerical aperture +  $\frac{\mu d \cos \alpha \sin \alpha'}{D}$ . This last term =  $\frac{\mu d \sin 2 \alpha}{2 D}$ , and will have a maximum when  $\alpha = 45^\circ$ , i.e. for N.A.'s

\* Journ. Quekett Micr. Club, Nov. 1902, pp. 349-52 (1 fig.).

† Dallinger-Carpenter, 8th ed., pp. 394-5.

just over unity. If the lamp is set near the instrument, so that  $D$  is small, the error may become 10 p.c. The lamp should be at least a foot away when the error sinks to 1 or 2 p.c.

**Simple Method of Focometry and Apertometry.\***—F. J. Cheshire first shows how Abbe's method † of determining the focal length of an optical system can be conveniently applied to a Microscope objective. The magnifying power of the objective is first determined with the draw-tube pushed in. This may be done by placing a sheet of ground glass on the top of the draw-tube, from which the eye-piece has been removed, and then focussing and measuring the image of a stage-micrometer upon it. The magnification  $M$  having been determined by this or any other method, the draw-tube is then pulled out to its full extent, and the magnification  $M'$  again found. Let  $\delta$  equal the amount of draw-tube extension, then the focal length  $f$  of the objective system =  $\frac{\delta}{M' - M}$ .

The author also gives allied ways of determining the focal and

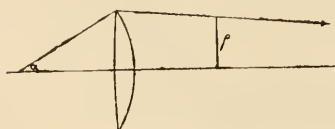

FIG. 14.

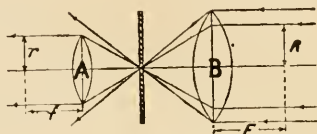

FIG. 15.

principal points of objectives, eye-pieces, &c., and optical tube-lengths. His methods of apertometry depend upon the following theory:—In the case of an aplanatic Microscope objective (fig. 14), let  $a$  equal the semi-angle of the maximum cone of light which it can take up from an object in a medium of refractive index  $\mu$ , and let  $\rho$  equal the radius of the disc of light in the upper focal plane. By a well-known equation,

if  $f$  equal the back or upper focal length, the N.A. =  $\mu \sin a = \frac{\rho}{f}$ . Now

consider the two lens-systems A and B (fig. 15) with a common focal plane and parallel incident light. Further, suppose that each system is spherically corrected for light converging to the common focal points. The system B is shown transmitting a cone of light of greater N.A. than the system A can take up. The effective and equivalent semi-apertures are  $R$  and  $r$  respectively, and for these the N.A.'s must

obviously be equal. Thus  $\frac{r}{f} = \frac{R}{F}$  or  $\frac{R}{r} = \frac{F}{f} = \text{a constant}$ . The

author describes how, by use of an Abbe's two-lens chromatic condenser and a disc of fine wire-gauze, he takes the necessary measurements. He also gives a comparative table of N.A.'s of a series of lenses obtained by Abbe's apertometer and by the above method. The two sets of results closely agree.

\* Journ. Quekett Micr. Club, Nov. 1902, pp. 331-42 (6 figs.).

† This Journal, 1892, p. 427.



**Watson's New Standard Electric Lamp.\***—This lamp (fig. 16), which is intended for Microscope work, has a 16 candle-power incandescent burner, with frosted glass bulb. It is carried on a lacquered brass standard, and, by means of a movable double arm, is adjustable in all directions. The bulb is inclosed in a nickelled reflector of parabolic shape, which has the simultaneous advantage of shielding the eyes and concentrating the light on the Microscope mirror. It can also be supplied with a special hood and iris diaphragm.



FIG. 16.

**Small Electric Light for Photomicrography.†**—W. Scheffer's first experiments were with a cravat-pin, which held a small electric lamp, lighted by a dry cell of American make. He then constructed a small lamp (fig. 17), in which the carbon filament lay as near as possible to the glass, so that the whole lamp might be brought into close proximity to the under side of the object-slide. The filament, magnified ten diameters, is shown more completely in fig. 18. The length of the filament (*a*, fig. 17) is 1 mm., the thickness 0·1 mm., and

\* W. Watson & Sons' Catalogue, 1902-3, p. 116.

† Zeitschr. wiss. Mikr., xviii. (1902) pp. 405-8 (3 figs.).

the distance from the object  $O$   $2.5$  mm. The cone of rays, seen broad-side, is shown in I. (fig. 18), and end-on in II.,  $B$  being the base (i.e.  $\alpha$  in fig. 18). In III. is represented a cone of rays proceeding from a base  $2.5$  mm. under similar conditions; the vertical angle of the cone

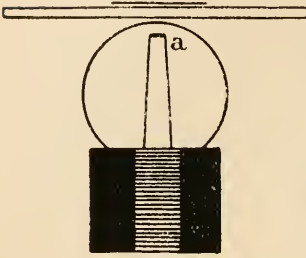

FIG. 17.

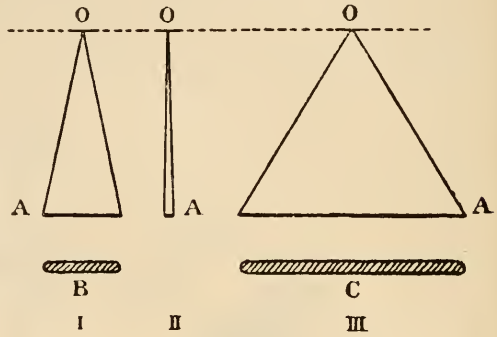

FIG. 18.

is obviously much more obtuse. This latter form is to be recommended for objectives of high aperture, and for objects visible by absorption (e.g. coloured preparations), the narrow filament being better for objects affected merely by refraction (e.g. diatoms, uncoloured preparations, &c.).

When the lamp is brought right under the object, a drop of cedar-oil will bring lamp and object-holder into close connection, and thereby much increase the effect of the light.

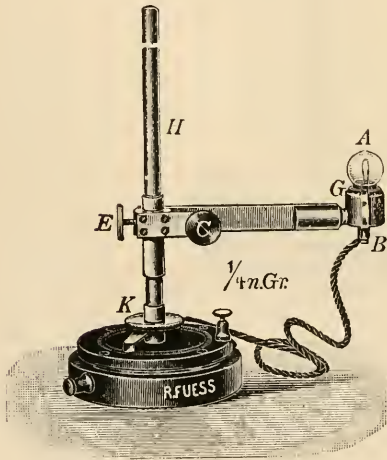

FIG. 19.

$B$  is so fitted with contact-springs that the lamps have merely to be inserted. The resistance-block is provided with a divided circle, so that the degree of illumination can be always regulated. An accumulator is recommended as a light-source. Among other advantages possessed by the apparatus, such as cheapness, simplicity, and constancy,

is the shortness of time-exposure, so that no condenser system is required.\*

**Illumination, and the Use of the Condenser in Histological Micrography.**†—A. B. Lee sums up his paper on this subject with the following advice :—“ If you desire to work with daylight, which I do not advise, put an object on the slide, turn the mirror so as to illuminate it, focus, centre the condenser, if it is not already centred for the objective to be used, set the diaphragm, and focus the condenser on a bar of the window. Afterwards never touch the diaphragm, nor the condenser rackwork.

“ If you desire to use a lamp without bull’s-eye, put it exactly in its marked position on the table, turn the edge of the flame towards the Microscope, put a coloured screen in front, turn the plane mirror so as to illuminate the condenser, centre the condenser, orientate the mirror so as to centre the flame-image, set the diaphragm, and focus the condenser. Afterwards never touch the diaphragm or the condenser, but regulate the light, if necessary, by your coloured screens.

“ If you desire to use the bull’s-eye, which I regard as the normal arrangement for a cytologist, proceed at first exactly as above, then place the bull’s-eye before the flame. Its focal distance from the flame and its azimuthal position having been once for all fixed by stop-screws, it will be in adjustment as soon as it fully illuminates the mirror, and it will be only necessary to slightly correct the orientation of the latter for getting the exact centring of the flame-image, and to re-focus the condenser for its new light-source. As before, never afterwards touch the diaphragm nor the condenser rackwork, but regulate the light, if necessary, by coloured screens.”

**Illuminating Apparatus for Metallography.**‡—1. *Electric Incandescent Lamp.*—

This is shown in fig. 20, and is of 150 candle-power, with Edison base, socket, binding-posts, stand, and elevating-screws. It is used with a large biconvex condensing lens.

2. *90° Automatic Focussing Electric Arc Lamp.*§—This (fig. 21) is used for projection or for photomicrography. It yields from 2000 to

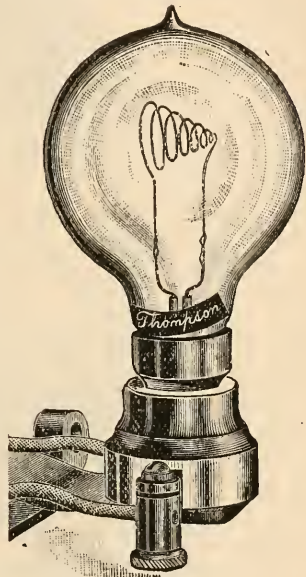

FIG. 20.

\* This method of illumination for visual purposes was exhibited before the Society, January 1883; it proved a complete failure, the definition being such as would satisfy no one but the merest beginner, *Journ. R.M.S.*, 1883, p. 29, figs. 1-6. It was reinvented in 1885 and 1886, v. *Journal* for those years, p. 303, figs. 48-54, and p. 1053, fig. 222.

† *La Cellule*, xix, 2nd fasc. (1902) pp. 405-31 (1 pl.); also as a pamphlet.

‡ Catalogue of the Boston Testing Laboratories, p. 16, fig. 14.

§ *Loc. cit.*, pp. 16-8, fig. 16.

4000 candle-power, and is adapted to both direct and alternating currents. It is enclosed in a nickel-plated light-tight hood.

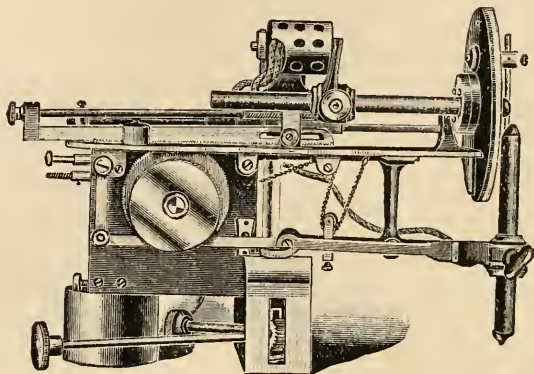

FIG. 21.

3. *90° Hand-fed Electric Arc Lamp.*\*—This (fig. 22) is for exactly the same purpose as the last.

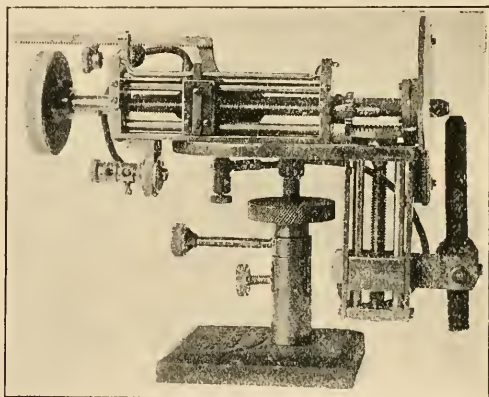

FIG. 22.

4. *Acetylene Gas Apparatus.*†—This illuminant is considered inferior to electricity. The arrangement of burners is shown in fig. 23, and the generator in fig. 24. They are coupled by india-rubber tubing.

\* Loc. cit., fig. 17.

† Loc. cit., p. 19, figs. 18 and 19.

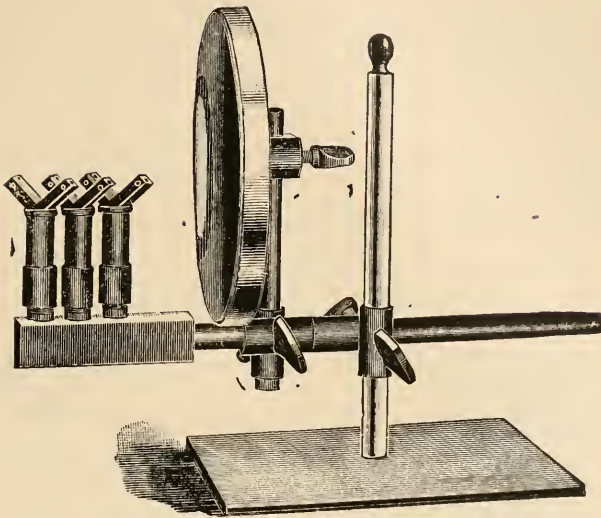

FIG. 23.

**Origin of the Davis Shutter.**—It will be found, on referring to the *Journal* for 1882, p. 262, that an iris diaphragm placed at the back of an object-glass (now known as a Davis shutter) was first suggested by Dr. Royston Pigott in 1869, for reducing the aperture of objectives. At that date Dr. R. Pigott maintained that wide-aperture objectives produced confused images.

**Simple Form of Reflecting Polariser.\***—F. J. Cheshire mounts, in the axis of the Microscope, a slip of ground glass G (fig. 25), about  $1\frac{1}{4}$  by  $2\frac{1}{2}$  in., at an inclination of  $33\frac{1}{2}^\circ$ , on a short spindle A, capable of rotation by a milled head B. The glass slip is blackened with Aspinall's enamel on its back and ground side. This polariser is mounted on the tail-piece of the Microscope in the same way as the usual mirror. Therefore when the spindle A has been rotated so as to bring the lamp-flame into view, the light is reflected at the proper angle

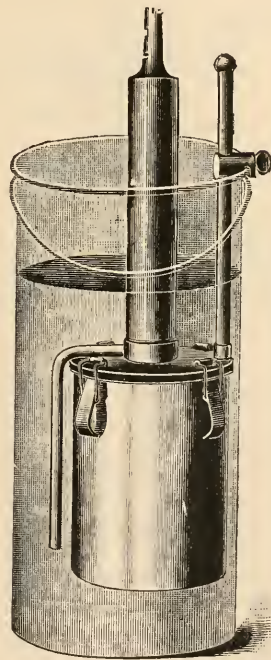

FIG. 24.

\* Journ. Quek. Micr. Club, Nov. 1902, pp. 353-4 (1 fig.).

for polarisation. The analyser is screwed into the bottom of the draw-tube, in which position it does not limit the field of view as when mounted in the eye-piece, and must be capable of independent rotation.

LEISS, C.—Ueber eine Verbesserung an der Polarisations-einrichtung von Mikroskopen.

[The essential part of the arrangement consists in the facility for moving aside the polariser, which is fitted in a sleeve on a hinged arm, the illuminating and condenser lenses being unaffected. The low-power condenser lens is independent of the polariser, and the latter is protected by a cover-glass.]

*Tschermak's Mineral. u. Petrog. Mitth.*, XXI. (1902) p. 45†.

LEISS, C. — Krystallpolymeter nach C. Klein.

[The author gives a full description of the instrument.]

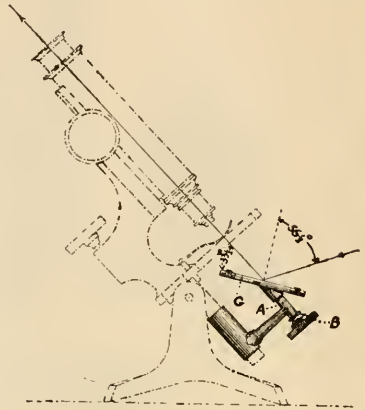

FIG. 25.

*Zeit. f. Instrumentenk.*, XXII. (1902) p. 201.

WENDT, G. VON.—Eine ausgezeichnete Beleuchtungsquelle für mikroskopische Zwecke.

[Strongly recommends the use of the Nernst lamp for microscopy. The light is constant, and when used with strong magnifications (2000 or more) the whole of the field is extraordinarily bright. The author considers it superior to any artificial or even natural light-source.]

*Zeit. f. wiss. Mikr.*, XVIII. (May 1902) pp. 417-8.

#### (4) Photomicrography.

**Stereoscopic Photography of Microscopic Objects.\***—W. Scheffer, after explaining the optical principles underlying the subject, proceeds to their application. When the object to be photographed has been brought into the field of view, the ocular is then removed, and one notes the position of the light-source (i.e. the carbon filaments of the lamp described in a previous section, fig. 18 *supra*). As the direction of the lateral displacement marks the horizontal, it is best to arrange that this displacement should be parallel to the edge of a plane. This is most conveniently attained by setting the lamp, with its stand, in such a position that the direction of the arm should be perpendicular to the longer edge of the plane, and this can be judged very accurately by the eye. By means of the screw a lateral movement in one direction is now given to the lamp until the carbon filament lies close to the periphery of the field; then it is similarly moved to the opposite side. When the observer has convinced himself of the accuracy of these positions, the ocular is re-inserted, the object laid on the stage, and the first photographic plate taken. The carbon filament is then moved to the opposite position and the second plate taken. Stereograms so obtained were compared with the object, and were found to give an excellent physical presentation, exactly corresponding to reality. The camera used was

\* *Zeitschr. f. wiss. Mikr.*, xviii. (1902) pp. 408-12 (2 figs.).

that described in the next section, and it was found that a period of three minutes was quite sufficient to take a stereogram, including the necessary adjustment of light, slides, &c. If the stereogram is required to produce the impression of vision from above, the horizontal must be so arranged that the true place of the lamp is the apparent position of the observer. A lamp should be chosen the length of whose filament is a third of the diameter of the aperture of the objective; the filament should be inclined lengthwise, at an angle of  $45^\circ$  to the horizontal.

**Improvements in the Vertical Microphotographic Camera.\***—W. Scheffer describes (fig. 26) an arrangement by which a Microscope can be used in the ordinary way, and yet almost instantaneously adapted for use with a vertical camera. The spacious foot-plate has two adjustable bars, which are secured by binding-screws, and serve for putting the Microscope into the exact position for accurate centring with the camera. A strong pillar is at the further end of the foot-plate. In the upper and perforated end of this pillar is a steel rod carrying the camera, and rotatory about its axis; it is notched for the adjustment over the Microscope, and is firmly clamped in this position by a screw. This arrangement secures the accurate adjustment of camera and Microscope. The rod not only bears sleeves with suitable arms for the camera, but is graduated so that the position of the ground-glass screen may be accurately controlled. The flame is so arranged that the double dark slide, &c. are not pushed, but dropped in; in this way all trouble from jamming is avoided. The dark slide is of tin, and is pressed down by springs.

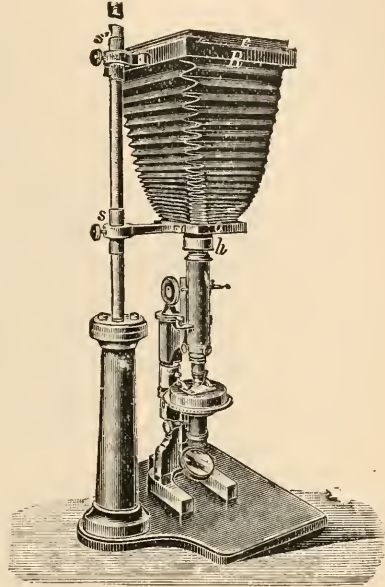

FIG. 26.

**Bagshaw's 'Elementary Photomicrography.'** †—This little book seems to correspond admirably with its title, and is written, as the author says in the preface, for the purpose of encouraging amateurs to commence the subject. It therefore aims at a clear exposition of principles and arrangements; and endeavours to show how many results can be obtained with simple apparatus that almost any one might be supposed to possess. There are ten chapters and an appendix, photomicrography with low powers being, naturally, more fully discussed than high power work, where, however, some very useful hints are given.

**RICHARDS, M. A.**—**Photomicroscopy of Metals as practised by Steel Companies.**

[A useful practical paper.]

*Journ. App. Micr.*, V. (1902) pp 1920-6 (8 figs.).

\* *Zeitschr. f. wiss. Mikr.*, xviii. (1902) pp. 401-4 (1 fig.).

† Iliffe & Sons, London, 1902, 68 pp.

(5) **Microscopical Optics and Manipulation.**

**Common Basis of the Theories of Microscopic Vision, treated without the Aid of Mathematical Formulæ.\***—J. Rheinberg explains in four chapters the principles underlying the formation of a microscopic image. These chapters were intended to form the commencement of a little book dealing fully with each of the various theories of microscopic vision, which have been, at any time, propounded, and the author considers that their publication at the present time may be opportune, in consideration of the interest recently aroused in the subject by Mr. J. W. Gordon's paper.† The great feature in Mr. Rheinberg's paper is a method of showing and explaining the action of a diffraction grating by successive stages, beginning with two slots only. There are numerous clearly drawn diagrams. The chapters are headed: (1) Elementary Considerations; (2) The Image of a Lens; (3) Diffraction and Diffraction Gratings; (4) On Obliquity of Incidence and Cones of Light.

**Steinheil and Voit's 'Handbuch der Angewandten Optik.'**‡—This important handbook on applied optics is less known in England than it deserves to be. The first volume, which is the only portion as yet published, contains some 314 octavo pages, 7 lithographic plates as well as numerous illustrations. It is intended as an exposition of the methods of calculating optical systems, and for their application to simple and achromatic lenses. It consists of 5 chapters and 4 appendices. The contents of the chapters are: (1) Reflection and Refraction of Light, pp. 1–32; (2) Fundamental Peculiarities of a Dioptric System, pp. 33–54; (3) Conditions for an actual Lens-System and Enumeration of Mistakes to be avoided, pp. 55–66; (4) Computation of a Lens and Discussion of its Image Errors, pp. 67–143; (5) Achromatic Objectives of Two Lenses, pp. 144–206. The four appendices, which are partly due to Dr. Seidel, deal with the mathematics of geometrical optics, and include various tables of reference.

HAÜSWALDT, H.—*Interferenzerscheinungen an doppeltbrechenden Krystallplatten im convergenten polarisirten Licht photographisch aufgenommen. Mit einem Vorwort von Th. Liebisch.* Magdeburg, 1902.

STREHL, K.—*Strenge Theorie der Lupe.*

[The author gives some notes and explanations on M. G. Quesneville's *Nouvelle Théorie de la Loupe* (Paris, A. Hermann, 1902). They concern the magnifying power of loupes, Microscopes, and telescopes.]

*Zeit. f. wiss. Mikr.*, XIX. (1902) pp. 32–4 (1 fig.).

THOMPSON, S. P.—*Some Experiments on the Zonal Aberration of Lenses.*

*Arch. Néerland.* [2] VI. (1901) p. 747.

(6) **Miscellaneous.**

**Cantor Lectures, 1902: Glass for Optical Purposes.**§—The lecturer, Dr. Glazebrook, devoted the first of the series of four lectures to an explanation of the defects of a lens (spherical aberration, astigmatism, coma, distortion, chromatic aberration), and of the chemical composition of optical glass. The second lecture showed how the defects were rectified in a modern microscopic objective. The third lecture dealt similarly with a photographic lens; and the fourth with telescopic objectives and combinations of telescopic and photographic lenses. The

\* *Zeitschr. f. wiss. Mikr.*, xix. (1902) pp. 1–32 (35 figs.).

† This Journal, 1901, pp. 353, 475. . . ‡ Leipzig, B. G. Teubner, 1891.

§ *Journ. Soc. of Arts*, Nos. 2601–7, Oct. and Nov. 1902 (59 figs.).



fourth lecture also explained the methods of lens-testing adopted at Kew Observatory and the official certificate issued. The lecturer referred to the following authorities as useful sources of information: Winkelmann's *Handbuch der Physik*; Müller Pouillet's *Lehrbuch der Physik*; M. von Rohr's *Theorie des Photographischen Objectivs*; Hovestadt's *Jenaer Glas*; Silvanus Thompson's translation of *Lummer's Photographic Optics*; and Dallmeyer's *Telephotography*.

**Molisch's New Freezing Apparatus.\***—This (fig. 27) is intended for exhibiting objects under the Microscope in laboratories. It is said

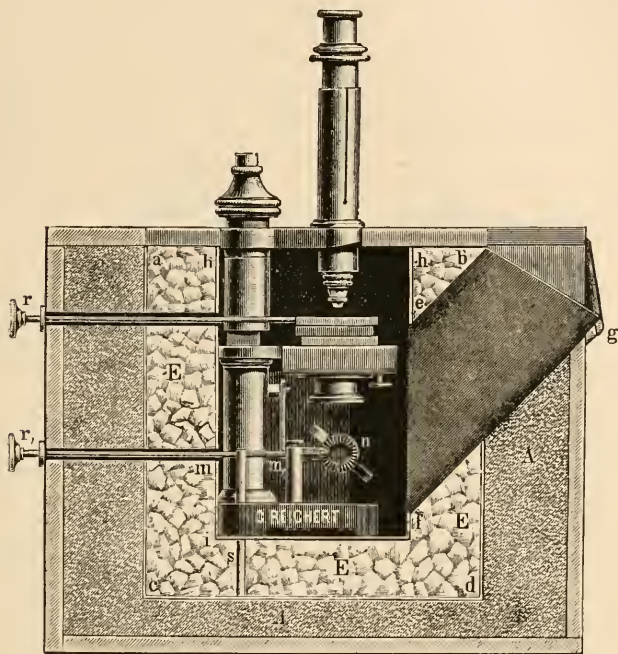

FIG. 27.

to be adapted for a constant temperature of  $-10^{\circ}\text{C}$ . A window admits light on to the mirror, and the various adjustments are effected by rods actuated from the exterior.

DONGIER, R.—Apparat zur Messung der Krümmung und anderer Constanten eines Optischen Systems. *Zeit. f. Instrumentk.*, XXI. (1901) p. 362.

KOHN, R.—Ueber mikroskopischen Electricitätsnachweis.

[The author reviews the limits of delicacy of the methods of electrical reactions observable by microscopic methods. He especially emphasises the electrolytic reactions when coloured or crystalline products are formed.] *Zeit. f. wiss. Mikr.*, XVIII. pp. 427-30.

STREHL, K.—Plaudereien über Optische Abbildung—Mikroskopie; Spektroskopie. [Conclusion of a series of articles.]

*Central-Zeit. f. Opt. u. Mech.*, XXIII. (1902) pp. 193-4.

WALLÉRANT, F.—Sur un nouveau modèle de réfractomètre.

*Bull. de la Soc. Franç. de Minéralog.*, XXV. (1902) p. 54.

\* *Zeitschr. angew. Mikr.*, viii. (1902) pp. 33-4 (1 fig.).

## B. Technique.\*

## (1) Collecting Objects, including Culture Processes.

**Apparatus for Collecting Samples of Earth for Bacteriological Examination.**†—H. W. Wiley describes an apparatus for the collection of samples of earth for examination. It consists of tubes of brass, similar in construction to a cork-borer, one end bevelled, so as to easily enter the soil. Both ends are closed by rubber balls of slightly greater diameter, and the balls are held in position by small rubber caps. The apparatus is sterilised for one hour on two or three successive days. The method of collecting is quite simple. A ditch is dug, some three or four feet deep, and wide enough to hold the operator, and one side is made smooth. Samples are taken by means of separate tubes, usually beginning three inches below the surface, and continuing at stated intervals to the bottom of the ditch. A platinum spatula, sterilised in the flame of an alcohol lamp, is used to remove the surface of earth at the point where the sample is to be taken; both rubber caps are removed from the tube, and the cutting edge is forced into the soil with a turning movement, so as to fill the interior with a core of earth. The tube is withdrawn, the rubber caps are replaced, and the whole apparatus enclosed in a covering of sacking for transmission to the laboratory.

✓ **Anaerobic Cultivation.**‡—D. Rivas claims that the following procedure for cultivating anaerobic organisms is new, simple, and effective. He uses a test-tube with a constriction in the middle (fig. 28). This is filled up to *a* with the medium, which is covered with a layer of oil reaching as high as *c*. The medium used is a mixture of bouillon, agar or gelatin, ammonium sulphide, and sulphindigotate of soda. To make 500 c.cm. of the medium in the least unpleasant way the following procedure is advised:—(1) Bouillon with 1 p.c. grape-sugar and 1.5 p.c. pepton, 474 c.cm. (2) Sulphindigotate of soda 10 p.c. solution in distilled water, heated for 1 hour at 100°, 1 c.cm. (3) Sodium sulphide 1 p.c. solution in distilled water, heated for 1 hour

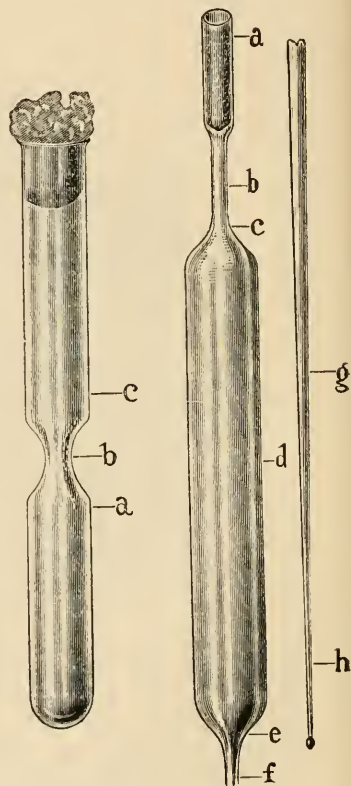

FIG. 28.

FIG. 29.

\* This subdivision contains (1) Collecting Objects, including Culture Processes; (2) Preparing Objects; (3) Cutting, including Imbedding and Microtomes; (4) Staining and Injecting; (5) Mounting, including slides, preservative fluids, &c.; (6) Miscellaneous. † Journ. Franklin Inst., cliv. (1902) pp. 81-91, 161-9 (1 pl.).

‡ Centralbl. Bakt., 1<sup>te</sup> Abt. Orig., xxxii. (1902) pp. 831-41 (4 figs.).

at 100°, 25 c.cm. The medium is then poured into the constricted tubes, covered with oil, and then the tubes are incubated for 48 hours.

In order to study isolated colonies, the author uses a flat tube with a long drawn out extremity (fig. 29), and holding about 8 c.cm. The agar or gelatin to be used is liquefied in test-tubes, inoculated, and diluted. The point of the long arm is then broken off at *h*, and then inserted into the tube containing the medium. By sucking at *a* the flat tube is filled as far as the neck. The neck and point are then melted off at *b* and *f*, and the closed plate placed in the incubator. As the tube is flat the colonies can be examined under the Microscope, and also easily photographed. By means of the media and this apparatus, the author has very successfully cultivated numerous anaerobic bacteria.

**Cultivating the Influenza Bacillus.\***—E. Czapelewski makes a blood-agar culture medium with pigeon's blood. Some feathers are removed with scissors from the bird's breast, and the surface thoroughly cleansed with cotton-wool soaked with alcohol. A slight incision is then made with a lancet, and the blood withdrawn by means of a pipette. The blood is then squirted into a flask, on the bottom of which is a layer of liquid agar (about 10 c.cm.). The ingredients are then mixed by careful shaking. The flask should be kept in a water-bath to prevent the agar setting. More agar is poured in until the correct tone of colour is obtained. The mixture is then passed into test-tubes or Petri dishes, and slants or plates made. With the usual precautions, such as are now employed in bacteriological laboratories, contaminations of the blood-agar are quite rare.

MEYER, E.—**Einige neue Apparate zum Schöpfen von Wasser zu bacteriologischen Zwecken.** (New apparatus for obtaining water for bacteriological purposes.) *Centralbl. Bakt.*, 1<sup>o</sup> Abt. Orig., XXXII. (1902) pp. 845-8 (4 figs.).

### (3) Cutting, including Imbedding and Microtomes.

**Simple Method of Making Thin Paraffin Sections.†**—W. Kolmer and H. Wolff describe a new procedure for making paraffin sections without the employment of fixatives. The chief agent is carbonic acid. To the cylinder containing the liquid gas is attached a tube 20 cm. long. Over the tube is placed a bag made of two layers of velvet. The bag is about the size of a child's head, and is fastened to the tube with strings and a clamp. The tap is opened for a moment. The bag becomes filled with solid CO<sub>2</sub>, which is transferred to a pan and stamped down with a pestle. After repeating the process several times, a cake of solid carbonic acid is obtained which will retain a temperature of about - 80° C. for 10-12 hours.

The cake is then put in an exsiccator, on the bottom of which is placed a small copper tube containing paraffin (melting-point 32°). On the layer of paraffin is placed the piece of fresh tissue (50 c.cm. in bulk). The piece freezes instantly. A dish of pentoxide of phosphorus is also placed in the exsiccator. The air is then removed by means of a water or mercury pump. In about 100 hours the piece of tissue is freed from its water. The exsiccator is then put in a thermostat to thaw the piece

\* *Centralbl. Bakt.*, 1<sup>o</sup> Abt. Orig., xxxii. (1902) pp. 667-70.

† *Zeitschr. f. wiss. Mikr.*, xix. (1902) pp. 148-50.

of tissue, and in this way saturation of the piece with paraffin is accomplished *in vacuo*. The blocks are easily cut on a freezing microtome, yielding sections  $5\ \mu$  thick.

The most important features of this method are that vital staining is retained in the sections, and Nissl's bodies are clearly evident.

**Preparing Serial Sections of Insects.\***—J. B. Scriven, while following generally the technique of Lowne, has introduced several time-saving modifications. After the object has been fixed, it is dehydrated in hot absolute alcohol and then placed straight away in the following imbedding medium. Paraffin ( $45^{\circ}\text{C.}$ ) 80 grs. white wax 10 grs., anhydrous creosote 2 minims, solution of caoutchouc in pure benzol (1 gr. to 5 fl. dr.), 2 minims. This medium cuts well at the temperature of the laboratory ( $16^{\circ}\text{C. circa}$ ). The sections are stretched on and fixed to the slide with warm water. After allowing the ribands of sections to dry by evaporation, the imbedding medium is removed by a rapid flooding with benzoline, which in its turn is removed with absolute alcohol. The other steps do not differ materially from those usually adopted.

**Examining Oligochætæ.†**—For his experiments on the regeneration processes in limicolous Oligochætæ, M. Abel used *Tubifex rivulorum* and *Nais proboscidea*. The regenerative parts, as well as a number of normal segments, were immersed for 1 to  $1\frac{1}{2}$  hours in Hermann's fluid (platinum chloride-osmic-acetic acid). This solution was found to act better than hot sublimate. After the preparations had been washed and hardened they were imbedded in paraffin, and then transverse and longitudinal sections  $5\ \mu$  thick were made. The sections were stained with hæmatoxylin or with Haidenhain's iron-hæmatoxylin solution.

#### (4) Staining and Injecting.

**Fixing Neutral Red.‡**—E. Golovine describes a method of fixing neutral red in the tissues after *intra vitam* staining. The animals used were Nematoda, Turbellaria, &c. The treatment of the object after *intra vitam* staining is divided into five sections: (1) precipitation of the neutral red; (2) fixation of the material; (3) washing and dehydration; (4) imbedding in paraffin; (5) after-staining of the sections. Neutral red may be precipitated and the object fixed at the same time by means of saturated solution of sublimate either alone or in combination with other fixatives such as picric acid, acetic acid, osmic acid, and platino-osmic-acetic acid mixture. Other fixatives mentioned are chromic acid and its salts, iodide of potassium, picric acid, bichloride of platinum, and chloride of gold. Washing is effected by means of saturated aqueous solutions of vanadic, picric, or molybdenic acids, in picrate of ammonia, and under certain circumstances in molybdate of ammonia. For dehydrating, mixtures in various proportions (seven formulæ are given) of water, saturated solution of molybdate of ammonia and  $90^{\circ}$  alcohol are used. The material is cleared up with toluol, xylol, and oil of cloves, after which it is imbedded in paraffin. The sections must be stuck on with

\* Journ. Quekett Micr. Club, viii. (1902) pp. 343-8.

† Zeitschr. f. wiss. Zool., lxxiii. (1902) pp. 3-4 (3 pls.).

‡ Zeitschr. f. wiss. Mikr., xix. (1902) pp. 176-85.

celloidin as albumen dissolves neutralised. For histological staining of the sections, the following solution is used: water 100 c.cm., hæmatoxylin 1 gm., chloral hydrate 7-9 gm., 50 p.c. acid molybdate of ammonia 20-30 drops. The mixture is exposed to the light for 8-10 days. The sections stain in a few seconds.

**Staining Axis-Cylinders with Carmin.\***—E. Chilesotti describes the following method for staining axis-cylinders. (1) Fixation, Müller's fluid for 4 months or more, or formol-Müller (1-10), or formol (about 1 p.c.) for 4 days at least. (2) Impregnation (only for pieces fixed in formol or in formol-Müller) in Weigert's solution for staining medullary sheaths. (3) Imbedding in celloidin. (4) Sectioning. (5) Staining. The staining solution is made by boiling for half-an-hour 1 gm. of carmin nacarat (Merck) finely powdered, in about 250 c.cm. of tap-water. After standing for 24 hours, the clear fluid is decanted off and then is added one drop of an alcoholic solution (70°) of hydrochloric acid (1 p.c.) to each c.cm. of aqueous carmin (3 c.cm. to 100 c.cm.). The mixture is then briskly shaken twice at intervals of 5 minutes. After standing for 24 hours the clear fluid is decanted off. Thymol 1-1000 is added to prevent mould. The sections remain at least 20 hours in the staining solution, and on removal are washed in distilled water. (6) Differentiation. The sections are immersed for 30 seconds in an aqueous solution of permanganate of potash 1-2500 (i.e. 5 parts of water and 1 part of  $\frac{1}{4}$  p.c. of Pal's solution). They are then transferred for 10-60 seconds to a saturated aqueous solution of sulphurous acid ( $\text{SO}_2$  5 p.c.). Wash in water and repeat the procedure, diminishing the stay in permanganate, until the section is of a rose colour traversed by reddish lines. Finally, 96 p.c. alcohol, carbol-xylol, Canada balsam.

The axis-cylinders and the ganglion-cells are stained red while the neuroglia and the medullary sheaths are quite decolorised. The red corpuscles, the nuclei of the neuroglia, are partially stained.

The author calls the attention of microscopists to this selective staining by means of carmin, a pigment which has been much neglected in recent times.

#### **Staining and Preservation of Series of Sections on Paper Slips.†**

A. Schoenemann, after mentioning the material worked with (nasal cavity of infants, petrous bone of adults), describes the method of decalcifying. At first 7 p.c. sulphuric acid was used, but afterwards sulphurous acid. The material was immersed in a saturated solution, and as long as it remained therein, remained hard, but on being transferred to water the bone salts dissolved out. After dehydration in absolute alcohol, the objects were transferred to a mixture of ether and oil of cloves (2-1), and then to Stepañow's celloidin, which consists of celloidin chips 1.5 gm., oil of cloves 5 gm., ether 20 gm., absolute alcohol 1 gm.

After a time, varying according to the size of the object, they were covered with chloroform, and when sufficiently hard the paper casing was stripped off and the mass placed in chloroform. When the hardening is complete the blocks are transferred to cedar-wood oil if they are to

\* Zeitschr. f. wiss. Mikr., xix. (1902) pp. 161-76. † Tom. cit., pp. 150-61.

be dry cut. If wet cutting be preferred, the chloroform bath is not used but the blocks are hardened in 80 p.c. alcohol. The author prefers the dry cutting method, and sticks the block on with a thick solution of collodion or with paraffin. As the sections are cut they are placed on strips of specially prepared colour-proof paper, one end of the strip being reserved for notes on identification, &c. When a sufficient number of sections have been placed in position they are flattened down with blotting-paper. The paper strips are then immersed in 80 p.c. alcohol, in which they are freed from the cedar-wood oil. When the sections are to be stained, the strips are placed in a water-bath to extract the alcohol, after which they are treated with hæmatoxylin, such as hæmalum, Grenacher's, Delafield's, in dilute solutions. The strips are placed in tap-water to bring out the colour well and then in 95 p.c. alcohol to which eosin has been added. In this way they are contrast-stained and partially dehydrated. The next step is to treat the sections with carbolxytol (1-3) and then with xytol. What the next procedure is depends on whether it be decided to preserve the strips or examine them in the dry or moist condition. If the latter, the strips are soaked in cedar-wood oil, and then placed on a slide and covered with a strip of glass or mica.

If they are to be preserved in the dry state, they are coated with elastinlack (Grübler). This varnish dries in from 12 to 24 hours. The strips must be kept in a cool place.

**Staining the Plague Bacillus.\***—E. Horniker obtains excellent polar staining of *B. pestis* by treating the air-dried and flame-fixed films with saturated alcoholic solutions of methylen-blue and gentian-violet. After allowing the stain to act for 1½ to 2 minutes, the preparation is washed with water.

**Staining Malaria Parasites with A-Methylen-Blue-Eosin.†**—K. Renter practises the following procedure. The air-dried film is fixed in formol-alcohol (formol 10, absolute alcohol 90), and then carefully dried with blotting-paper. The preparations are then immersed in the stain (aq. destill. 20 c.cm., A-methylen-blue-eosin (Grübler) 30 drops). By tilting the capsule containing the staining solution after the manner of developing a photographic plate the staining process is materially accelerated; it should be completed in 15-20 minutes. The film is then washed with distilled water, and after having been mopped up and dried in the air, is mounted in balsam.

**Staining the Parasites of Malaria perniciosa.‡**—G. Maurer recommends the following procedure for staining the parasites of pernicious malaria. The chief requisites are a good film, careful drying and hardening, and a very ripe alkaline methylen-blue solution. The slides must be perfectly clean, and the film made after the method of Jancso and Rosenberger. The film is first dried in the air, and then fixed by immersing it for 10 to 15 minutes in alcohol-ether. On removal it is dried in the air or in the flame. It is then ready for

\* Centralbl. Bakt., 1<sup>te</sup> Abt. Orig., xxxii. (1902) pp. 926-8.

† Tom. cit., pp. 842-5.

‡ Tom. cit., pp. 695-717 (3 pls.).

staining. In a 60 c.cm. flask 10 drops of methylen-blue solution are mixed with 25 c.cm. of tap-water, and in another flask 15 drops of eosin solution with 25 c.cm. of tap-water. The latter is then poured into the former, after which the blood preparation is immersed in the mixture and kept moving about briskly for about five minutes. On removing the preparation water is poured over it to get rid of the superfluous stain. The preparation is now probably too blue, and the excess is removed by immersing in distilled water. If this be not sufficient, the preparation must be dried and again treated with distilled water.

The ordinary methylen-blue solution may be used (1 p.c. aqueous methylen-blue med. Höchst with  $\frac{1}{2}$  p.c. soda), but 1-2 p.c. ammonia or  $\frac{1}{10}$  p.c. caustic potash are better than the soda. This solution takes 4 to 6 weeks to ripen. The eosin solution is a 1 p.c. solution in distilled water. Though the proportion of 10 methylen-blue to 15 eosin was found to be best for most cases, yet when the methylen-blue is weak or unripe, it may be increased to 15-25, and conversely, when too ripe and strong may be reduced to 7-15.

**Demonstration of Flagella in Coccaceæ.\***—D. Ellis has demonstrated the presence of flagella in a large number of Coccaceæ by the following method. The samples, which were obtained from Král's laboratory, were sown first on dextrose-agar and Spirillum-agar. As soon as any growth was perceived, a trace thereof was inoculated on fresh agar, and this procedure was repeated until movements in individual cocci became evident, after which they were re-inoculated and cultivated until a culture was found suitable for flagella preparations. In general A. Meyer's method of fixing and staining (see this *Journal*, 1900, p. 373) was adopted, though modifications in the fixation, length of mordanting, and staining were had recourse to. As a rule, the preparations were fixed for 5 minutes at 40° C., and then mordanted for 4-6 minutes at room temperature. For staining, acid-violet was used; this was heated until it vaporised, after which the preparation was allowed to stand for 2 minutes at room temperature.

As the result of the foregoing procedure, the author infers that all species of *Coccaceæ* are flagellated.

**Stain for Elastic Fibres.†**—J. H. Stebbins, jun., recommends the following method by which elastic fibres are stained dark-blue to blue-black. Dissolve 2 grm. fuchsin and 4 grm. resorcin in 200 c.cm. of boiling water. While boiling add 25 c.cm. of liquor ferri sesquichlorid. and boil for 5 minutes longer; then cool and filter. Dissolve the precipitate collected on the filter in 200 c.cm. of 94 p.c. alcohol by boiling, and when all is dissolved bring the volume of the fluid up to 200 c.cm. with 94 p.c. alcohol. Finally add 4 c.cm. of HCl, mix well by shaking, and the stain will be ready for use.

The material may be fixed in Zenker's fluid, or in formaldehyde. The sections are stained for 20 to 60 minutes, washed in absolute alcohol, cleared in xylol, and then mounted. If desired, they may be previously contrast-stained with carmin.

\* Centralbl. Bakt., 2<sup>te</sup> Abt., ix. (1902) pp. 546-60 (2 pls.).

† Journ. N.Y. Micr. Soc., xvi. (1901) pp. 4-5.

## (5) Mounting, including Slides, Preservative Fluids, &amp;c.

**Making Preparations of Crystals for the Micropolariscope.\***—S. E. Dowdy says that the first essential of success is to get the slides perfectly free from grease. Rubbing them with a paste made by working up a little prepared chalk with equal parts of rectified spirit and liquid ammonia, drying, and finally polishing on chamois leather, answers well. Make a saturated solution of the chemical in cold distilled water in a test-tube. Warm the supernatant fluid so that it may take up a little more of the salt in solution. Deposit a drop or two of the warm solution in the centre of a slide and allow it to spread. If it do not form a film but remain as a globule it is a sign that the slide is still greasy. If a film forms, it should be covered with a watch-glass and the slide put aside to cool. The results are better from slow cooling, but the process may be hastened by heating the liquid on the slide until a thin film of salt appears at the edge and then putting aside to cool. When formed, the crystals should be mounted at once in xylol-balsam of thick viscid consistence.

## (6) Miscellaneous.

**Interesting Extract from Hooke.†**—"Nature is not to be limited by our narrow apprehensions; future improvements of glasses may yet further enlighten our understanding and ocular inspection may demonstrate that which as yet we may think too extravagant either to suppose or feign."

This quotation occurs in connection with a letter received from "the ingenious and inquisitive Mr. Leeuwenhoeck, of Delft," sent October 5, 1677. In this letter, Leeuwenhoeck speaks of the vast number of animalcules to be seen in an infusion of pepper, and Hooke calculates that over 8,000,000 of these minute animals exist in a single drop.

The work from which the extract is taken is entitled 'Lectures and Collections made by Robert Hooke, Secretary of the Royal Society,' 1678, p. 118. The latter part of this collection has a second title, 'Microscopium or some new Discoveries made with and concerning Microscopes.'

**Handbook of Instructions for Collectors.‡**—The authorities of the British Museum (Natural History) have issued in book form the series of pamphlets, treating of the collecting and preservation of specimens, which were chiefly drawn up for the better information of voluntary collectors resident abroad. The various chapters have been written by different members of the staff of the Natural History Museum. Much valuable information is contained in the booklet, though a few more diagrams would have been useful adjuncts to the verbal descriptions. On the other hand, illustrations such as that of a cyanide bottle seem somewhat superfluous, and the morality of the advice (p. 129) to bribe customs officers is more than doubtful.

**Physiological Histology.§**—G. Mann's *Methods and Theory of Physiological Histology* is bound to command widespread interest among

\* Engl. Mech., lxxvi. (1902) pp. 319-20.

† Brit. Mus. Cat., 233 h. 5.

‡ Printed by order of the Trustees of the British Museum, London, 1902, 137 pp., with illustrations.

§ Oxford, Clarendon Press, 1902, vii. and 488 pp.



physiologists and pathologists, as it is the first work in the English tongue which has treated the practice and theory of fixation and staining in a thorough and scientific manner. Its contents will well repay a careful examination, and the volume will, no doubt, soon be found in every well appointed laboratory. The first nine chapters deal with the various aspects of fixation. These are followed by others describing the methods of bleaching, decalcifying, injecting, and of obtaining sections. In chapters fourteen to twenty, dyes and staining are treated of. To these succeed impregnation methods, the chemistry of some tissue-constituents, and microchemical reactions. In chapter xxiv. the theory of staining is discussed at considerable length and with much erudition and knowledge.

In the last chapter are described the methods for rendering preparations permanent. The book concludes with an appendix in which the chemistry of dyes is dealt with in much detail, and with a note on micro-anatomical reaction.

In conclusion, we may say that the author has succeeded in producing a work of considerable merit, which is marked throughout by accurate knowledge of the theory of the subject and by practical experience of the methods discussed. It is the work of one in authority, and quite unlike many compilations which profess so much.

‘**Modern Microscopy.**’\*—This useful handbook, which this year has reached its third edition, is the outcome of the knowledge and experience of M. I. Cross and M. J. Cole, by whom the text has been entirely revised and considerably enlarged. The information regarding the Microscope and microscopical technique has been brought up to date and much extended in scope. A new feature of the present edition is a chapter on the choice and use of microtomes. The general get-up of the volume, which is freely illustrated, is very good.

**Microscopic Examination of Paper Fibres.**†—W. R. Whitney and A. G. Woodman, in a very useful communication, give an account of the procedure they adopt for examining paper fibres microscopically. As a rule, a magnification of 60 diameters only is required, but higher powers are at times useful. The Microscope must be fitted with apparatus for viewing objects with polarised light. The paper to be examined is torn into small bits, and these are boiled for a few minutes in a 1 p.c. solution of caustic soda; then the pulpy mass is poured on a fine sieve (about 100 meshes to the linear inch) and washed with water until practically free from alkali. The pulp is transferred to a bottle half filled with water, and shaken vigorously to break up any lumps. It is not advisable to use glass beads or garnets to assist in the dissociation, but it may be necessary, in order to separate the fibres, to fray them gently in a mortar. The fibres may be inspected in water or glycerin and water, and permanent mounts made in agar, glycerin-jelly, or Canada balsam. Several should always be prepared, in order to be sure that examples of the various cell-forms may be obtained. The slides are to be examined by direct, and by polarised light, and their

\* Baillière, Tindal & Cox, London, 1903, xvi. and 292 pp. and 77 figs.

† Technology Quart., xv. (1902) pp. 272-307 (94 figs.).

various characteristics noted down. In this way their identity may be narrowed down to three or four fibres, and their exact identification established by reference to detailed descriptions given by the authors in their valuable paper.

**Method of Making Collodion Tubes.\***—K. Kellerman pours 3 p.c. collodion into test-tubes of suitable size. The tubes are then rapidly revolved, so as to coat the interior. The superfluous collodion solution is poured off, and the tube is then placed in the inverted position to allow it to drain easily, and to dry and harden the film. The tube is allowed to stand for three minutes to one hour, and then filled with water. This loosens the collodion, so that the tube is easily drawn out.

**Ink for Writing on Glass.†**—P. G. Unna uses an ink for provisionally marking slides composed of zinc oxide 7.5, gelanth 7.5, distilled water 15.

**New Micrometer.‡**—This instrument (fig. 30), devised by Sir J. Hooker, obviates the inconvenience of the double measurement involved

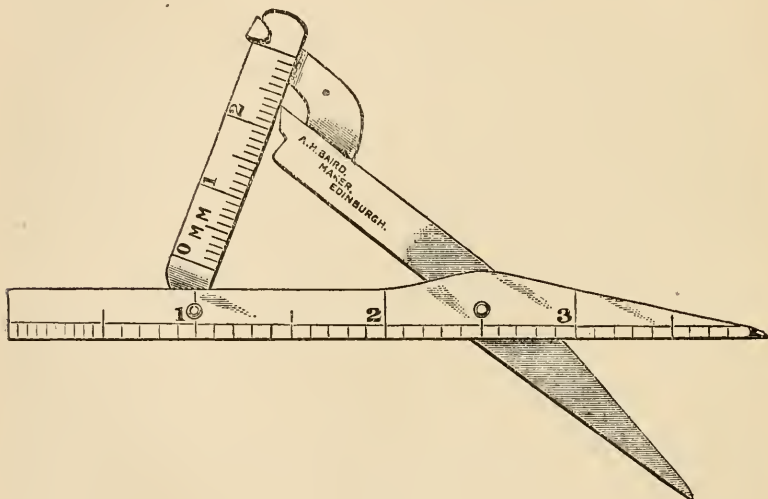

FIG. 30.

in the use of compasses and a rule. It records the length of an object up to a fraction of an inch or millimetre, one side of the scale being graduated to inches and the other to millimetres. It is specially useful for work with the dissecting Microscope, as the object may be measured without removing the eye from the ocular. The instrument is 4 in. in length, and as it is graduated for the ordinary and metric systems, it furnishes a ready means of converting the reading of one scale into terms of the other. It is made by A. H. Baird of Edinburgh.

\* Journ. App. Micr., v. (1902) p. 2038.

† Monatsch. Prakt. Dermatol., xxxii. (1901) p. 343.

‡ A. H. Baird, Edinburgh: Catalogue, 1902 (1 fig.).

**New Colony-Counter.\***—L. S. Ross describes a new bacteria colony-counter (figs. 31-33), of which a great feature is that the glass bearing the ruled lines can be brought quite close to the growth, by which a great source of error is eliminated. A glass disk ruled to square centimetres is mounted on the end of a short barrel that moves freely by

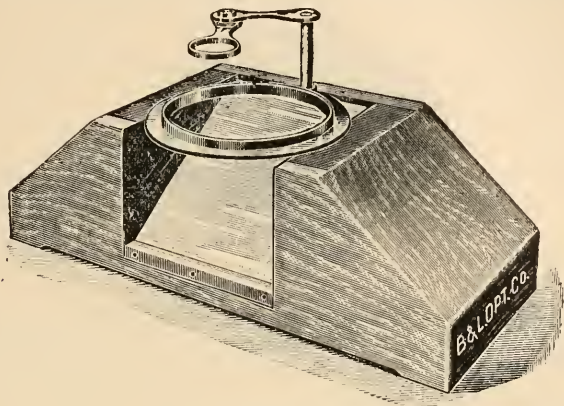

FIG. 31.

screw-thread within a collar. A block similar to that used in the Barnes dissecting Microscope has a metal circle on the top over the mirror, of a size to hold the 100 mm. Petri dish; a rim is on the circle to hold the dish in position. Underneath the circle a mirror, or a black surface if

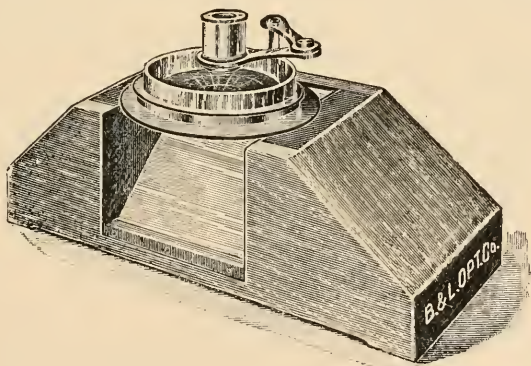

FIG. 32.

desired, is placed at an angle of 45 degrees. A sliding-post bearing a jointed arm is set into the block, to hold the lens in counting. The dish to be counted is set upon the circle, the cover is removed, and the barrel is placed disk down inside the dish, the collar holding the barrel resting upon the edge of the dish. The barrel is lowered through the

\* Journ. App. Micr., v. (1902) pp. 1970-1 (3 figs.)

collar by means of the screw-thread until the ruled glass is close to the gelatin. The barrel is of such a length that the ruled glass may be brought close to the gelatin in dishes of various depths. By means of the jointed arm the lens is swung into place and may be carried over the entire surface of the dish. The apparatus is made by Bausch and Lomb.

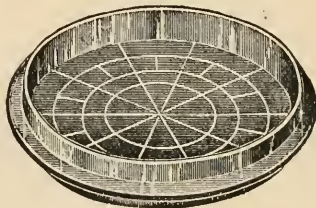

FIG. 33.

- ABBA, F.—*Manuale tecnico di microscopia e batteriologia applicate all'igiene.*  
Torino (Claussen) 1902, Svo, 671 pp., about 351 figs.
- CAJAL, S. RAMON Y.—*Elementos de histologia normal y de técnica micrográfica.*  
3rd ed., Madrid, 1901, Svo.
- EHRlich, P., KRAUSE, R., MOSSE, M., ROSIN, H., UND WEIGERT, C.—*Encyklopädie der mikroskopischen Technik mit besonderer Berücksichtigung der Färbelehre.* Abt. 1, 2.  
Wien (Urban u. Schwarzenberg), 1903, Svo, 800 pp. and numerous figs.
- GOBHAM, F. P.—*A Laboratory Course in Bacteriology.*  
London (Saunders), 1901, Svo.
- STRASBURGER, E.—*Das botanische Practicum. Anleitung zum Selbststudium der mikroskopischen Botanik für Anfänger und Geübtere, zugleich Handbuch der mikroskopischen Technik.*  
4th ed., Jena (Fischer), 1902, Svo, 771 pp. and 230 figs.
- WRIGHT, A. E.—*New Procedures for the Examination of the Blood and of Bacterial Cultures.*  
[(1) On the possibility of dispensing with the standard pipettes and micro-metrical rulings of the hæmocyto-meter. (2) On a method of determining under the Microscope the number of micro-organisms contained in bacterial cultures. (3) On a simple procedure for coagulation tubes of standard calibre; also a note on the practical importance of the information obtained from the coagulometer.]  
*Lancet*, 1902, II. pp. 11-7.

### Metallography.

**Metallography:** an Introduction to the Study of the Structure of Metals chiefly by the Aid of the Microscope.\*—This is the title of a useful work by A. H. Hiorns. The author believes it to be the first on the subject in the English language, and as the principles of metallography are yet in their infancy, he has not attempted any strictly logical basis of treatment. The book is divided into thirteen chapters, the first three of which are devoted to methods of preparation; the others treat of the various metals and their alloys. The book is also subdivided into sections, and the numerous photomicrographs amply

\* Macmillan & Co., 1902, 158 pp. and 96 photomicros.

illustrate our present knowledge of the subject. A glossary of technical terms is appended.

**Fracture of Metals under repeated Alternations of Stress.\***—J. A. Ewing and J. C. W. Humphrey have investigated by means of the Microscope the process by which iron becomes "fatigued" and breaks down, when subjected to repeated reversals of stress. It is shown that, although the greatest stress may be much within the limits of elasticity, it produces rupture after many reversals. The first visible effect is the production of slip-bands here and there on individual crystals. These gradually become more numerous. They also become accentuated and broadened, and their edges turn rough and burred, apparently as a result of grinding of one surface on the other over the plane in which the slip has occurred. At a later stage certain of the slip-bands develop into cracks, the cracks spread from crystal to crystal, and fracture ensues.

**Volatilisation and Recrystallisation of the Platinum Metals.†**—For the measurement of high temperatures by means of thermo-elements, it is usual to employ a combination of a platinum wire with one of platin-rhodium (Le Chatelier), or with one of platin-iridium (Barus). L. Holborn and F. Henning have undertaken experiments to test the suitability of these materials, and especially to discover whether the crystalline structure suffered any degeneration in consequence of prolonged heating. It was found that alloys of platinum and iridium at a temperature of 1500° C. lose weight considerably, and metallographic examination showed extensive disintegration of structure. The other metals and alloys were practically unchanged.

**CAMPBELL, W.—Upon the Structure of Metals and Binary Alloys.**

[Discusses methods, crystalline structure, effects of strain, effects of heat treatment, and representatives of the various groups of binary alloys.]

*Metallographist*, V. (1902) pp. 286-334 (38 figs.).

**HOUGHTON, S. A.—The Internal Structure of Iron and Steel with special reference to defective Material.**

[A very clearly written paper, copiously illustrated with excellent photographs.]

*Metallographist*, V. (1902) pp. 257-35 (34 figs.).

\* Proc. Roy. Soc., lxxi. (1902) p. 79.

† S.B. d. k. Preuss. Akad. d. Wiss. zu Berlin, xxxix. (1902) pp. 136-43 (11 photographs).

PROCEEDINGS OF THE SOCIETY.

---

MEETING

HELD ON THE 17TH OF DECEMBER, 1902, AT 20 HANOVER SQUARE, W.  
DR. HENRY WOODWARD, F.R.S., PRESIDENT, IN THE CHAIR.

The Minutes of the Meeting of the 19th of November, 1902, were read and confirmed, and were signed by the President.

The List of Donations to the Society (exclusive of exchanges and reprints) received since the last Meeting was read, and the thanks of the Society were voted to the donors.

Handbook of Instructions for Collectors. Issued by the British } From  
Museum (Nat. Hist.). (London, Svo, 1902) .. .. . } Mr. F. Justen.

Mr. J. J. Vezey explained that Dr. Hebb had been unexpectedly detained as an examiner at Cambridge, and regretted therefore he could not be present; he (Mr. Vezey) had undertaken to fulfil his duties. He then read the following list of nominations for Officers and Council to be submitted for election at the Annual Meeting of the Society in January next:—

*President*—Dr. Henry Woodward.

*Vice-Presidents*—Messrs. Wm. Carruthers, G. C. Karop, A. D. Michael, and E. M. Nelson.

*Treasurer*—Mr. Vezey.

*Secretaries*—Rev. Dr. Dallinger and Dr. Hebb.

*Council*—Messrs. J. M. Allen, Wynne E. Baxter, Conrad Beck, Dr. Braithwaite, Rev. E. Carr, Messrs. A. N. Disney, J. W. Gifford, Rt. Hon Sir Ford North, Messrs. H. G. Plimmer, T. H. Powell, P. E. Radley, and C. F. Rousselet.

*Librarian*—Mr. Radley.

*Curator*—Mr. Rousselet.

*Auditor on behalf of the Council*—Mr. J. M. Allen.

The Fellows having been requested to elect one of their number as Auditor to act with Mr. Allen, Mr. C. L. Curties was thereupon proposed, seconded and duly elected as Auditor on behalf of the Fellows of the Society.

Mr. C. F. Rousselet exhibited an apparatus for drawing objects natural size, which was figured in the Society's *Journal* for 1900 (p. 734), but had not been previously exhibited. The instrument had now been

sent to them by Messrs. Bausch and Lomb. It consisted of an upright pillar mounted on a firm base, and carrying an eye-piece which consisted of two right-angled prisms cemented together and silvered on their facing surfaces with the exception of a small hole, and having a third prism cemented to these. The pillar also supported a rigid arm, which carried a mirror at each extremity fixed at an angle of  $45^\circ$  to the horizontal. The object to be drawn was placed under one of the mirrors, and the paper on which the drawing was to be made was similarly placed below the other, the image being seen through the eye-piece projected upon the paper, on which it could easily be traced with a pencil.

The thanks of the Meeting were voted to Messrs. Bausch and Lomb for sending this apparatus for exhibition, and to Mr. Rousset for explaining it.

---

Mr. E. M. Nelson's note on a Two-speed Fine Adjustment was read by Mr. Vezey, and illustrated by a diagram drawn upon the board.

The thanks of the Society were voted to Mr. Nelson for his communication.

---

The Rev. R. Freeman read a paper, by Mr. F. R. Dixon-Nuttall and himself, 'On the genus *Diaschiza*,' which was illustrated by a number of drawings shown upon the screen by means of the Epidiascope.

The President, in moving a vote of thanks to Mr. Freeman, said it was obviously impossible to judge fully of the merits of an exhaustive paper of this kind from simply hearing it read, but they would look forward to reading it for themselves in the *Journal*, with the beautiful illustrations they had seen exhibited before them in the plates accompanying the text of the paper.

Mr. C. F. Rousset said: The paper on the genus *Diaschiza* to which we have been listening will be welcomed by all students of the Rotifera. It is one of those which has required a very great deal of work—work of some years indeed, and much more than appears on the surface of it. For I know by experience how difficult it is, and how long a time it takes to check all the reported facts and find out the mistakes or inaccuracies of previous students of such an obscure and difficult group of Rotifers as the genus *Diaschiza*.

The mistakes were due mostly to the imperfection of the tools with which these predecessors had to work, but they were none the less mistakes, likely to lead astray, and involving considerable work to find out and correct. I think the authors are to be congratulated on the success with which they have revised this genus, and also on their good fortune in having found all the well authenticated species in their neighbourhood. The fine figures which we have seen on the screen, drawn by Mr. Dixon-Nuttall, are so good and full of detail, that the identification of the species will no longer offer the difficulties which it formerly did.

It will have been noticed that several well-known names will have to disappear as synonymous, such, for instance, as *Diaschiza semiaperta*, which is obviously identical with *Furcularia gibba* of Ehrenberg, and will now be known as *D. gibba*.

In the case of *D. caeca*, no less than four of Mr. Gosse's species are melted down as varieties of only one. Mr. Gosse was a very keen observer, and no one could draw better than he did such details as he could see. But obviously, he could not draw what his Microscope could not reveal, and when we know from his son's biography, that Mr. Gosse bought a Microscope in 1850, which, regardless of modern improvements, he continued to use throughout his life, we can understand how it is that some of the more minute features in the anatomy of Rotifers escaped his keen scrutiny.

By the courtesy of Dr. H. M. D. Phillpotts, of Babbacombe, Torquay, its present possessor, and the kindness of Dr. Cressey, who has brought it from Torquay, this Microscope is here to-night for your inspection. You will observe it is an old but first class Microscope, made by Hugh Powell about 1840. It is identical with the old Microscope presented to the Society by Messrs. W. Watson and Sons, in November last year, a description of which, by Mr. Nelson, will be found in the *Journal* for 1901, p. 728. The three object-glasses—1-in.,  $\frac{1}{2}$ -in., and  $\frac{1}{4}$ -in., all provided with a Lieberkuhn—are exceedingly good even now, and according to modern standards the two higher powers only lack aperture; but this want of aperture, or N.A., is precisely what prevented Mr. Gosse from seeing the very minute details, such as the dorsal and lateral antennæ in many Rotifers, the fine setæ above the toes of the Diaschiza. &c., which are missing in his drawings. A binocular body is also present, and must have been added later in the sixties; but Dr. Hudson has told me that Mr. Gosse could not use a binocular owing to the shortness of focus of one of his eyes.

This, then, is the very interesting Microscope with which Mr. Gosse did all his work on the Rotifera, and it certainly is a very efficient instrument, and one of the very best types available at the time when he acquired it, and our very best thanks are due to Dr. Phillpotts for kindly sending this instrument for exhibition, and to Dr. Cressey for bringing it up from Torquay.

The thanks of the Meeting were voted to Mr. Dixon-Nuttall and Rev. R. Freeman for their paper, to Mr. Rousselet for his remarks, and to Dr. Phillpotts for the loan of this very interesting old Microscope, and to Dr. Cressey for bringing it from Torquay for this Meeting.

---

Mr. E. R. Turner made a communication 'On a new Arrangement for taking Photomicrographs in Colours,' and illustrated the subject by the exhibition of a number of examples shown on the screen.

The problem of photography in natural colours, said Mr. Turner, has been approached from many different standpoints. Very few processes, however, have been found to be of value. The most successful at present known was suggested by James Clerk Maxwell in a lecture at the Royal Institution in 1861, and although he had not the material to enable him to put his theory into practice, it has been proved since that what he advanced was of real practical value.

He suggested that the theory of colour-vision might be employed as a means of obtaining a reproduction of the natural colour, and that if the three colours to which the eye was found to be sensitive were repre-



sented by three photographs, then by projecting these three photographs each through a colour-screen similar to that used in obtaining the photographs, and superposing the images, an exact reproduction of the various colours of the original would be obtained.

Instead of projecting the images by means of a lantern, photographs in the form of prints or transparencies may be obtained by a modification of the same idea. Ducos du Harmon was the first to obtain a picture in pigments by this method, but his effects were not satisfactory. In 1890, Mr. F. E. Ives produced some good results in Philadelphia, and in 1894 exhibited them in London; but in his lecture before the Society of Arts, April 22, 1896, he described the process as almost impracticable. The two specimens shown, which were made by Mr. Ives about this date, are, however, very good.

Briefly, the details of this process are as follows:—Three negatives are taken of any given subject by means of an ordinary camera, three colour-screens, as suggested by Maxwell, being employed in order to produce the requisite colour records, these colour-screens being respectively red, green, and blue, and the plates employed being sensitive to these colours. Then three pieces of mica, split to the thickness of thin cover-glass, which have been coated on one side with bichromated gelatin, are exposed, one under each negative, to daylight. The particular coloured light, which was absorbed by the colour-screen when taking the negative, will be represented by clear glass, and the light will render this exposed portion insoluble, so that, upon washing away that portion of the gelatin which remains soluble by means of warm water, an image in clear insoluble gelatin is obtained, which in its varying thickness is an exact record of the coloured light absorbed by the colour-screen; thus the red screen absorbed the green and blue light, and the resulting gelatin print is stained in a greenish-blue dye; the green screen absorbs red and blue light, and the gelatin print from this negative is stained with a dye which transmits red and blue; the print from the negative taken through the blue screen is stained yellow.

When making the exposure of the bichromated gelatin under the negative, the mica is placed next the negative, so that the insoluble image which results from the exposure to daylight may have the mica on which to adhere; if printed on the gelatin side, a layer of soluble gelatin will remain between the insoluble image and the support. The necessity of printing through the support at once demonstrates the superiority of mica over celluloid, the former being so thin that the finest details will print sharp. A sheet of celluloid, on the other hand, is of quite an appreciable thickness, and microscopic detail cannot be secured.

The special advantages of using Lumière's process for scientific work are, that, in the first place, by the employment of mica in the place of celluloid, very fine detail can be secured. As the mica has no tendency to become distorted, there is no difficulty in obtaining accurate registration of the three monochromes. Thirdly, as there is no necessity to balsam the three images together, the resulting picture will not be affected by prolonged exposure to the heat of the projection lantern. By the employment of exactly the same process to obtain all three monochromes the scale of gradation is preserved, and the most delicate tints may be accurately reproduced.

Mr. R. L. Gleason also exhibited several interesting slides in illustration of the same process, and gave details as to exposure, &c.

The President expressed the thanks of the Society to Mr. Turner and Mr. Gleason for their demonstration of a process which he was sure had a very great future before it. He thought that practical demonstrations such as this were of great value, not merely as showing what could be done by colour processes, but as a great incentive to others to experiment for themselves.

---

Mr. Vezey thought it scarcely necessary to say how glad the Fellows of the Society were to see Dr. Dallinger amongst them again, and to know that his health had been sufficiently recovered to enable him to be present.

Dr. Dallinger said he was greatly obliged to Mr. Vezey and to the Fellows of the Society for the welcome they had given him. It had been a source of great pain to him to be absent from their Meetings, but the doctors had told him that the only way to recover was to keep from exposure at night and from any mental strain or excitement, and this he had done with so far beneficial results, and he hoped to be in his place in future as usual.

---

Notice was given that the Society's rooms would be closed from December 24 to January 3 inclusive.

---

The following Objects, Instruments, &c., were exhibited:—

Rev. R. Freeman:—Drawings, shown on the screen by means of the Epidiascope, in illustration of the paper by Mr. F. R. Dixon-Nuttall and himself on the Genus *Diaschiza*.

Mr. E. R. Turner:—Slides shown on the screen in illustration of his communication on taking Photomicrographs in Colour.

Mr. R. L. Gleason:—Slides shown on the screen in illustration of Colour Photomicrography.

Mr. K. I. Marks:—*Melicerta tubicoloria*.

Mr. C. F. Rousselet:—H. Bausch's Apparatus for Drawing Objects Natural Size.

---

New Fellows:—The following were elected *Ordinary* Fellows:—  
H. Th. Güssow, Rev. Thomas Nevill, Lieut.-Col. George Lyon Tupman.

ANNIVERSARY MEETING.

HELD ON THE 21ST OF JANUARY, 1903, AT 20 HANOVER SQUARE, W.  
DR. HENRY WOODWARD, F.R.S., PRESIDENT, IN THE CHAIR.

The Minutes of the Meeting of the 17th of December, 1902, were read and confirmed, and were signed by the President.

At the request of the Secretary, Messrs. Freshwater and Rheinberg undertook the duties of Scrutineers, and proceeded with the ballot for Officers and Council of the Society for the ensuing year.

The List of Donations to the Society (exclusive of exchanges and reprints) received since the last Meeting, was read, and the thanks of the Society were voted to the donors.

	From
Cross and Cole, <i>Modern Microscopy</i> . 3rd edition. (London, 8vo, 1903) .. .. .	} <i>The Publishers.</i>
Hovestadt, Dr. H., <i>Jena Glass, and its Scientific and Industrial Applications</i> . Translated and edited by J. D. Everett and Alice Everett. (London, 8vo, 1902) .. .. .	} <i>The Publishers.</i>
Pantocsek, Dr. Józef, <i>A Balaton Kovanoszatai vagy Bacillariái</i> . (Budapesth, 8vo, 1902) .. .. .	} <i>The Author.</i>
Atti dell' Instituto Botanico dell' Università di Pavia. Vol. vii. pt. 1. (Milano, 8vo, 1902) .. .. .	} <i>Prof. G. Briosi.</i>
Journal of the Board of Agriculture. Vol. ix. No. 3. (London, 8vo, 1902) .. .. .	} <i>The Board of Agriculture.</i>

The President called attention to three frames of photographs taken for the lantern by the Sanger-Shepherd three-colour process, exhibited in the room by Mr. Norman, who was invited to offer some remarks in explanation.

Mr. Norman said that the slides were examples of the Sanger-Shepherd process of colour photography, as applied to medical photomicrography. A blow-through jet and zirconium lime were used for the illumination of the specimens from which the negatives were made. This form of jet he preferred, in a private house, for its safety, as well as its simplicity and efficiency. Zeiss's or Swift's objectives were employed, with Zeiss's No. 4 compensating or projection oculars for the higher powers. There was no special difficulty in this colour process, but if ordinary photomicrography required care and patience, then this work required more care, patience and perseverance.

The Cadet Rapid Spectrum plates, which were used for the negatives, although so fast and so sensitive to practically all the colours of the

spectrum, were most easily worked if a suitable developer was used; and they allowed ample illumination in the dark room without showing fog.

In staining up the films he had found the best results were obtained by first staining them fully in the normal solution, then to wash out the excess of colouring matter under a good rose tap, and finally to stain up again in a very weak solution of the dye, by which means the very fine details were secured without overstaining other parts where the impressions were strongest.

He thought it would be admitted that the slides exhibited showed the possibilities of this process, and its undoubted value in teaching histology, pathology, and bacteriology, and many other subjects that required the aid of illustration by the lantern.

On the motion of the President, the thanks of the Society were voted to Mr. Norman for his communication.

---

The President announced that the Scrutineers had handed in the result of the ballot, and declared that the whole of those Fellows whose names had been printed in the lists had been duly elected, as follows—

*President*—Henry Woodward, Esq., LL.D. F.R.S. F.G.S. F.Z.S.

*Vice-Presidents*—William Carruthers, Esq., F.R.S. F.L.S. F.G.S.; George C. Karop, Esq., M.R.C.S.; \* A. D. Michael, Esq. F.L.S.; \* E. M. Nelson, Esq.

*Treasurer*—J. J. Vezey, Esq.

*Secretaries*—Rev. W. H. Dallinger, LL.D. D.Sc. D.C.L. F.R.S. F.L.S. F.Z.S.; R. G. Hebb, Esq., M.A. M.D. F.R.C.P.

*Other Members of Council*—Jas. Mason Allen, Esq.; \* Wynne E. Baxter, Esq., J.P. F.G.S. F.R.G.S.; Conrad Beck, Esq.; \* Robert Braithwaite, Esq., M.D. M.R.C.S. F.L.S.; Rev. Edmund Carr, M.A. F.R.Met.S.; A. N. Disney, Esq., M.A. B.Sc.; \* Jas. William Gifford, Esq.; \* The Rt. Hon. Sir Ford North, P.C. F.R.S.; Henry George Plimmer, Esq., F.L.S.; Thomas H. Powell, Esq.; Percy E. Radley, Esq.; Charles F. Rousselet, Esq.

*Librarian*—Percy E. Radley, Esq.

*Curator*—Charles F. Rousselet, Esq.

The President said that on his own behalf he thanked the Fellows of the Society for the honour they had done him in again electing him as their President.

---

Dr. Hebb then read the Report of the Council for the year 1902, as follows.

#### REPORT OF THE COUNCIL FOR 1902.

##### FELLOWS.

*Ordinary*.—During the year 1902, 18 new Fellows have been elected, whilst 9 have resigned and 10 have died. Amongst the latter the Council makes special mention of the following:—Mr. A. W. Bennett, Mr. T. Comber, Prof. J. W. Groves, Dr. W. M. Ord, Mr. C. M. Vorce, Rev. Prof. Wiltshire.

\* Those with an asterisk (\*) had not held during the preceding year the office for which they are elected.

*Honorary.*—Two Honorary Fellows, H. De Lacaze Duthiers and Dr. R. L. Maddox, have died, and the Right Hon. Lord Rayleigh has been elected an Honorary Fellow. The number of Honorary Fellows is now 46.

The list of Fellows now contains the names of 432 Ordinary, 1 Corresponding, 46 Honorary, and 83 Ex-Officio Fellows, being a total of 562.

## FINANCES.

The amount received for Subscriptions during the past year is about 50*l.* less than that in 1901. This is chiefly accounted for by the slackness of some Fellows in the payment of their Annual Subscriptions, there being about 70*l.* in arrears. The Council hopes that by calling attention to this fact, Fellows will assist the Treasurer by being more prompt in their payments in future. Every Fellow who has not paid in the early months of the year when the subscription is due has received three separate applications for payment, besides a slip of reminder attached to two issues of the *Journal*. This entails much extra and unnecessary work on the clerical staff, besides putting the Society to increased expense for postage.

The admission and compounding fees received during the year have been invested in India 3 per cents., raising the amount of stock held in that security to 474*l.* 19*s.* 5*d.*

The Council has found it possible to make a large saving in the cost of the *Journal*, reducing the outlay on that item by about 50*l.* in the year. It is hoped that a further reduction will be made in the current year. This is most important considering the large outlay under this head, and it is gratifying to note that the economy has been effected without impairing the value of the *Journal*.

## JOURNAL.

During the past year, several changes have been made in the editorial staff. The post of General Editor, rendered vacant by the death of Mr. A. W. Bennett, was assigned to Mr. R. G. Hebb, M.D., while the care of the Botanical Department was accepted by Mr. A. B. Rendle, D.Sc., Assistant in Botany at the British Museum, an appointment on which the Society is much to be congratulated. Another valuable accession has been that of Mr. J. W. H. Eyre, M.D. F.R.S.E., Bacteriologist to Guy's Hospital.

The original papers which have appeared during the year have been quite up to the usual level in value and number, while the abstracts in Zoology, Botany, and Microscopy have fully maintained their previous high standard.

## INSTRUMENTS AND APPARATUS.

The Instruments and Apparatus in the Society's Collection continue to be in good condition.

During the past year, the following additions have been made:—

May 21, 1902.—Two pieces of Apparatus, Forceps, &c., designed by the late Mr. R. Macer for exhibiting flies feeding. Presented by Mrs. Macer.

May 21.—A Cornelius Varley Patent Graphic Telescope. Presented by Mr. E. M. Nelson.

Oct. 15.—An old Microscope, by Cary, with Varley Stage. Presented by Mr. A. W. Waters and Miss Celia Waters.

Oct. 15.—An old Microscope made by George Jackson, a former President of this Society. Presented by Mr. John Jackson.

#### THE LIBRARY.

The Library is in good condition. Several valuable donations, notably those included in the bequest of the late Mr. Bennett, have been received during the present year.

The Author and Subject (card) Catalogues have been completed by the Librarian.

New Rules for the regulation of the Library have been revised by Sir Ford North, and adopted by the Council.

#### EXCURSIONS.

At the suggestion of the President and through his kindness in making the necessary arrangements, a new feature was introduced in the summer in the form of two Excursions. The first, on 21st June, when by the kind invitation of the Hon. Walter Rothschild, about forty Fellows visited his Museum and the Park at Tring. Mr. Rothschild provided conveyances to take the party from Tring station to the Museum where he personally welcomed the visitors, and with his curator, Dr. Hartert, showed them his collection of zoological specimens and gave them much valuable information. The outing was not only instructive but throughout most enjoyable.

The second Excursion took place on 5th July, when by the kindness of the Council of the Zoological Society, a party of Fellows visited the Gardens and were shown round by Mr. F. Beddard, F.R.S., the Prosector.

The Council desires to record its indebtedness to the Hon. Walter Rothschild and the Council of the Zoological Society for these invitations, and to all those who assisted to make the occasions so pleasant and profitable. The President kindly accompanied the Fellows on both occasions.

Visits to the Natural History Museum in the new year are being provisionally arranged, and the Council hopes that this new departure may result in benefit to the Fellows and help to promote social intercourse among them.

---

The Treasurer then read his Annual Statement of Account, with the Audited Balance Sheet (see p. 125).

He said there was nothing to add to this by way of remarks, as the only matter upon which he should have said anything—namely as to the desirability of greater promptness in paying subscriptions—had been fully dealt with in the Report of the Council.

The President said that having now heard the Report and Balance Sheet read, he would ask some Fellow present to move their adoption.

Dr. CASH STATEMENT FOR THE YEAR ENDING 31ST DEC. 1902. Cr.

1902.		£	s.	d.	1902.		£	s.	d.
To Balance from 1901	.. .. .	37	5	0	By Rent, Coals and Attendance	.. .. .	..	..	..
" Admission Fees	.. .. .	38	14	0	" Salaries and Reporting	.. .. .	..	..	153 16 3
" Compounding Fees	.. .. .	23	12	6	" Books, &c., purchased	.. .. .	..	..	85 10 0
" Annual Subscriptions—					" Bookbinding	.. .. .	..	..	20 4 2
1895	.. .. .	0	10	0	" Expenses of Journal—				
1897	.. .. .	1	9	11	Printing Journal, and Reprints				
1898	.. .. .	1	11	6	and Postage	.. .. .	£403	11	11
1899	.. .. .	1	11	6	Illustrations	.. .. .	74	11	4
1900	.. .. .	16	5	6	Editing	.. .. .	159	1	5
1901	.. .. .	22	10	9					637 4 8
1902	.. .. .	572	15	6	" Purchase of India Three per Cents., 35l. 17s. 1d.	.. .. .	..	..	36 0 6
1903	.. .. .	15	15	4	" Placed on Deposit	.. .. .	..	..	50 18 0
					" Refreshments at Meetings	.. .. .	..	..	13 10 0
" Interest on Investments and Deposit Account	.. .. .	632	10	0	" Stationery	.. .. .	..	..	10 0 2
" Sale of Journal	.. .. .	50	16	7	" Fire Insurance	.. .. .	..	..	2 0 0
" Receipts for Advertisements	.. .. .	337	10	11	" Postage and Petty Expenses	.. .. .	..	..	36 13 2
" " Sale of Surplus Books	.. .. .	60	0	0	" Instruments purchased	.. .. .	..	..	0 15 9
" " List of Fellows and Reprints	.. .. .	5	0	0	" Balance in hand	.. .. .	..	..	61 14 0
" " List of Fellows and Reprints	.. .. .	6	13	8					
" Withdrawn from Deposit	.. .. .	50	0	0					
									£1242 2 8

Investments.

- 400l. Nottingham Corporation Stock Three per Cents.
- 315l. 11s. 1d. New South Wales Three and Half per Cents.
- 400l. North British Railway Three per Cents.
- 474l. 19s. 5d. India Three per Cents.
- 150l. on Deposit at Union Bank.

We have examined the foregoing Account, and compared the same with the Vouchers in the possession of the Society; we have also verified its Securities as above mentioned, and find the same to be correct.

J. J. VEZEY, *Treasurer.*  
 J. MASON ALLEN } *Auditors.*  
 C. LEEB (CURTIS) }

Mr. Marshall said he had great pleasure in moving that the Report and Balance Sheet now presented be received and adopted, and that they be printed in the usual way. He thought the Report was one upon which the Society was to be congratulated, and he was pleased to note that the balance in hand was about double the amount of that which was reported at the previous Annual Meeting.

The motion having been seconded by Mr. Gardner, was put to the Meeting, and carried unanimously.

---

The President said he had great pleasure in announcing that it had been proposed that the Society should pay two visits to the Natural History Museum at South Kensington. The first of these would take place on Saturday, February 14th, when those who wished to join the party would assemble in the Central Hall, near the Owen statue, at 2 p.m., and he hoped himself to conduct them to some points of interest in the Geological Department. The second visit was arranged for Saturday, March 14th, at the same time (2 p.m.), when Mr. Carruthers would act as conductor. Mr. Carruthers proposed to show them some of the treasures of the Botanical Department, including Smith's original collection of Diatoms, and also a remarkable series of original botanical drawings of great interest. No further notice would be given.

---

The President also called attention to some models made by Mr. Kirk, exhibited in the room, and to the restored section-model of a remarkable specimen of an abnormal form of Cephalopod shell, *Ascoceros*, from the Upper Silurian of the Island of Gothland, made and coloured by Mr. G. C. Crick, F.G.S., of the Geological Department, British Museum of Natural History.

---

The President then delivered his Annual Address, taking as his subject the development of life as shown by the fossil organisms found in the geological strata. In illustration of this some diagrams were exhibited, one of which showed the ancestral forms of modern Crustacea, or the origin and evolution of the class in geological time, by means of a chart prepared by J. W. Salter and H. Woodward in 1865; also two diagrams, one of which gave the order in which the series of sedimentary strata were deposited, and the other an approximate representation of their relative thicknesses; and he explained that the newer Secondary and Tertiary strata had been successively built up from the destruction of those more massive older formations. Attention was directed to the greater thickness of the Palæozoic rocks, as compared with that of the Mesozoic and Cainozoic, and that it was only in the very latest of these deposits that remains of man occurred. The President then proceeded to give a *résumé* of his address, and by means of numerous illustrations thrown upon the screen by the Epidiascope, traced the development of the various classes of organic forms, from the earliest and simplest met with, such as the Radiolaria, the Foraminifera, the Sponges, Cœlenterata, Annelids, Starfish, Echinoderms, Mollusca, &c.,



to the Nautilus and Octopus, examples of which were still living. He also traced the Crustacea, Arachnida, and Insecta, from the Palæozoic rocks to the present day.

Mr. A. D. Michael said they had listened that evening to a most fascinating address upon a subject which had engrossed attention as perhaps no other could be said to have done; for of all the questions which had occupied the thoughts of men of science, there was surely none more attractive than that of the origin and development of life. As to the origin, he thought he might safely say that to-day they knew no more than when the inquiry commenced, which was equivalent to saying that at present they knew nothing; but they had just enjoyed a most graphic delineation of its development so far as it is known to biologists, and the series of pictures which had been put before them did enable the mind to grasp what was the extent of our present knowledge of the subject, and to trace the connection between the earliest forms of life which geologists are acquainted with and those existing at the present time. In this most interesting study they had the advantage of being instructed by one who was such a thorough master of the subject as their President. He was sure they all felt deeply indebted to the President for his address, and he had great pleasure in moving that the best thanks of the Society be given to him for it, and that he be asked to allow it to be printed in the *Journal*.

Dr. Braithwaite having seconded the motion, it was put to the Meeting by Mr. Michael, and carried with acclamation.

The President said that he felt he should consult the feelings of those present at that late hour of the evening by simply returning his best thanks for the indulgence shown to him by the Fellows present who had listened so patiently to what he feared must have seemed a somewhat disjointed communication. He had prepared probably three times as much matter for his discourse as he ought to inflict upon them, but though he had been so imprudent as to bring it with him, he had refrained from reading it. He hoped, however, when they saw it in print it might prove more acceptable to read than in the brief *résumé* he had attempted to lay before them.

---

The Rev. A. G. Warner said they were very conscious of how much they were indebted to their Honorary Officers for the labour they had bestowed upon the Society in organising and preparing the business and in enabling it to be carried out satisfactorily. Much of their work was hardly seen by anyone, but it had been done well, and the only return they could make was to express their gratitude on an occasion like the one then present. He therefore had great pleasure in moving that a most hearty vote of thanks be given to the Honorary Officers of the Society for their services during the year.

The motion having been duly seconded, was put to the Meeting by the mover, and carried unanimously.

Mr. J. J. Vezey said that Dr. Hebb had asked him to respond to this vote of thanks on behalf of himself and his colleagues. They had been very pleased indeed to do the work, and being human, it was a great pleasure to them to know that it had given satisfaction and to

hear this expression of the Fellows' appreciation. He hoped they would continue to deserve the kind things which had been said about them—they would at least endeavour to do so—and he trusted the Society was entering on another prosperous year.

Mr. D. J. Scourfield then moved "That the thanks of the Society be given to the Auditors and Scrutineers."

Mr. K. J. Marks having seconded the motion, it was put to the Meeting by the President and unanimously carried.

The President again mentioned the proposed visit to the Natural History Museum on 14th February, and whilst giving a cordial invitation to all, reminded them that only those near the centre of a large crowd of persons might be able to hear all that was said in explanation of what was to be seen.

**The following Objects were exhibited :—**

The President, in illustration of his Address :—Diagrams showing the Order in which the Series of Sedimentary Strata were deposited and their approximate relative thicknesses ; Chart showing the Ancestral Forms of modern Crustacea ; Drawings of various classes of Organic Forms shown on the screen by means of the Epidiascope ; Model of Ascoceros ; Recent *Scorpio afer*.

Mr. Albert Norman :—Photomicrographs in Colour by the Sanger-Shepherd Process. (1) Anthracosis, Lung,  $\times 16$ . (2) Taste-Buds in Tongue,  $\times 65$ . (3) Injected Small Intestine,  $\times 16$ . (4) Scalp of Negro, Long. Section,  $\times 15$ . (5) Transverse Section of Scalp,  $\times 50$ . (6) Epithelioma of Skin,  $\times 65$ . (7) Stalk of Polypus,  $\times 13$ . (8) Angioma of Liver,  $\times 18$ . (9) Human Kidney, Injected Vessels,  $\times 18$ . (10) Hæmorrhagic Smallpox Skin,  $\times 50$ . (11) Actinomycosis, Human Liver,  $\times 400$ . (12) Actinomycosis, Tongue of Cow,  $\times 500$ . (13) Blood Film, Eosin Meth.-Blue,  $\times 500$ . (14) Bac. Anthracit. Gel. Impression, Edge of Colony,  $\times 500$ . (15) Bac. Lepreæ, Skin,  $\times 1000$ . (16) Tubercle Bacilli, with Pnemococci Encapsuled, Sputum,  $\times 1000$ . (17) Malaria Crescent,  $\times 1000$ . (18) Tetanus Bacilli, showing Flagella,  $\times 1000$ . (19) Eosinophile Cells, in Plague Specimen,  $\times 1000$ . (20) Bipolar Plague Bacilli, Spleen,  $\times 1000$ . (21) Tubercle Bacilli, Sputum,  $\times 1000$ . (22) Typhoid Bacilli, showing Flagella,  $\times 1000$ . (23) Tsetse Fly Parasites in Guinea-pig's Blood.  $\times 1000$ . (24) Bac. subtilis, Spores,  $\times 1000$ .

**New Fellows.**—The following were elected *Ordinary* Fellows :—Messrs. Louis Rutledge Gleason, Albert William Henly, and Dr. Edmund Johnson Spitta.



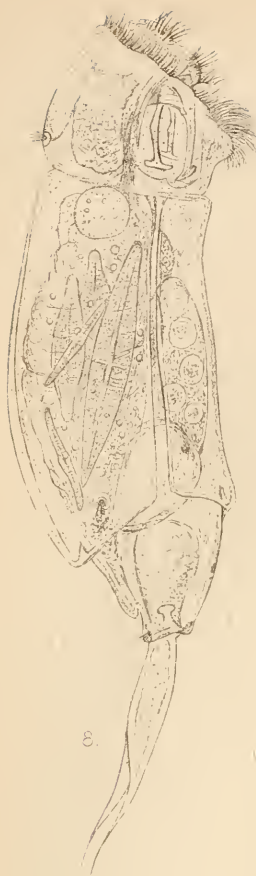

8.



8b



8c



8e

8d



9.

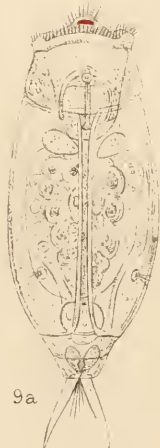

9a



10



10a

FR. Dixon-Nuttall del. ad nat.

West, Newman lit.

Diaschizae.

JOURNAL  
OF THE  
ROYAL MICROSCOPICAL SOCIETY.

APRIL 1903.

TRANSACTIONS OF THE SOCIETY.

I. (continued).—*The Rotatorian Genus Diaschiza:*  
*A Monographic Study, with Description of a New Species.*

By F. R. DIXON-NUTTALL, F.R.M.S., and  
The Rev. R. FREEMAN, M.A.

(Read December 17th, 1902.)

**Diaschiza Hoodii** Gosse.

Pl. II. figs. 5, 5a, and 5b.

SYNONYMY.

*Plagiognatha gracilis* Tessin-Bützow.

*Diaschiza valga* Bilfinger.

„ „ Weber.

„ „ *ramphigera* Gosse.

BIBLIOGRAPHY.

GOSSE, P. H.—Twenty-four new Species of Rotifera. Journ. Roy. Micr. Soc., 1887, pl. i.

HUDSON & GOSSE.—The Rotifera. London, 1889, vol. ii. p. 79, pl. 22, fig. 15.

HUDSON & GOSSE.—The Rotifera. London, 1889, Suppl. p. 38, pl. 31, fig. 32

TESSIN-BÜTZOW.—Rotatorien der Umgegend von Rostock. Arch. 43, d. Fr d. Naturg. i. Mecklenb., p. 148, pl. i. fig. 10.

EXPLANATION OF PLATE III.

All figs, except fig. 8b,  $\times$  476.

Fig. 8—*Diaschiza eva* Gosse. Lateral view.

„ 8a „ „ „ Dorsal view.

„ 8b, c, d, e—*Diaschiza eva* Gosse. Various shapes of toes.

„ 9—*Diaschiza globata* Gosse. Lateral view.

„ 9a „ „ „ Dorsal view.

„ 10 „ „ *exigua* Gosse. Lateral view.

„ 10a „ „ „ Dorsal view.

April 15th, 1903

K

BILFINGER, L.—Zur Rotatorienfauna Württembergs. Zweiter Beitr. Jahresh. d. Ver. f. vaterl. Nat. i. Württ., 50. Jahrg., 1894, p. 53.

WEBER, E. F.—Faune Rotatorienne du Bassin du Léman. Genève, 1898, p. 549, pl. 20, figs. 26-8.

*Spec. Char.*—Body elliptical, gibbous dorsally, flat ventrally, showing slight dorso-ventral compression; head sub-conical; neck a marked constriction; face sub-prone, protruding in a very marked beak-shaped projection of buccal orifice; lorica somewhat flexible; dorsal cleft well marked; lateral cleft well marked; eye cervical, single; foot short, stout, tapering, terminal, not ventral; toes more than  $\frac{1}{4}$  length of rest of body, furcate, style-shaped, well decurved; incus very long.

Gosse's description is very weak, and the figure errs in accentuating the angles of the lorica; and it was with some difficulty that we satisfied ourselves about the identification of this species. But from his drawing of *Hoodii* and his description of what he calls the bird's beak in *ramphigera*, and his reference to the length of the incus, especially of the fulcrum in both, we are satisfied that his two species are one, and that we have it here, and that the name *Hoodii* must take precedence of *ramphigera*.

Tessin-Bützwow described this species as *Plagiognatha gracilis*, a name which is unavailable owing to *Furcularia gracilis* Ehr., which is certainly to be included with this species in the genus *Diaschiza*. His (T.-B.'s) description is also lacking in detail, and he makes the same mistake about the beak-like process.

This beak-like process is one of the most marked features of this species. It is strange that Gosse, Tessin-Bützwow, and Weber (sub *D. valga*) should fall into the error of taking it for a projection of the trophi, whereas it is absolutely distinct from the jaws, and consists of the extended lips of the buccal orifice. Bilfinger and Weber (loc. cit.) also make the mistake of naming this species *D. valga*, while their figure and descriptions are certainly those of *D. Hoodii*. Of this we shall have more to say under *D. valga* at the end of this monograph.

This is one of the placid species of the genus, like *D. ventripes*, and prefers creeping about the flocculent matter found on water-weeds to swimming.

It never, so far as our observations go, throws its toes over its back, and, in fact, does not contort itself so much as the other species do, owing to the slightly stiffer texture of its lorica.

The dorsal cleft, which is well marked, gapes posteriorly.

The cervical eye lies at the extremity of the large brain-sac, and is a single red pigment-spot without a lens.

The foot is terminal, *not ventral*, and carries the usual setæ situated on a small papilla, and generally four in number. It tapers rapidly to the last pseudo-joint, which is of fair length, and only slightly wider than the combined bases of the toes.

The toes are stiff and decurved, ending in a sharp point, and are nearly always carried wide apart, when the points are seen from a dorsal view to curve in slightly towards one another.

The gastric glands are somewhat large, but never tinted.

The jaws are very striking owing to the exceptionally large and long incus which ends in a decided fulcrum. They *never* protrude through the buccal orifice.

It feeds on flocculent matter, not on diatoms, and often fills its stomach with a brown mass of food studded with fat-globules.

*Size*.—Total length  $\frac{1}{130}$  in. (194  $\mu$ ); toes alone  $\frac{1}{545}$  in. (47  $\mu$ ); breadth  $\frac{1}{380}$  in. (67  $\mu$ ); height  $\frac{1}{475}$  in. (53  $\mu$ ).

Common.

*The Male*, Pl. II. fig. 5*b*.—This sex occurred in water from Knowsley Park on November 15, 1901, in several examples. It has the four plates, the usual clefts between them, and the cervical eye exactly as in the female.

Like the males of many rotifers (but unlike that of *D. gibba*) its length is very small compared with that of the female, being little more than half, whereas the male of *D. gibba* is  $\frac{3}{4}$  of the female in length.

The toes are fairly long in proportion to the trunk, thin and decurved.

It is without manducatory organs, the sperm-sac filling the greater part of the trunk.

In habits, it is very restless, contorting itself into all sorts of shapes and sizes. The figure represents the most normal shape and attitude.

*Size*.—Total length  $\frac{1}{224}$  in. (113  $\mu$ ); toes alone  $\frac{1}{940}$  in. (27  $\mu$ ); breadth  $\frac{1}{850}$  in. (30  $\mu$ ); height  $\frac{1}{940}$  in. (27  $\mu$ ).

Rare.

### *Diaschiza Derbyi* sp. n.

Pl. IV. figs. 13, 13*a*, and 13*b*.

*Spec. Char.*—Body ovate cylindrical, laterally compressed; head sub-conical; neck a slightly marked constriction; face sub-prone; corona extending well down ventral surface; lorica not unusually flexible; dorsal cleft well marked; lateral cleft wide, well marked; eye cervical, on dorsal extremity of brain lobe, with one, sometimes two, clear spheres in front; foot short, flexible, terminal; toes about  $\frac{1}{3}$  length of rest of body, nearly straight, slightly upcurved, often thrown up over back.

This species appeared in small numbers in the lake and in a pond in Knowsley Park, Lancashire, at various times throughout the winter of 1900-1901, until May of the latter year, when it

seemed to disappear; and we did not find it again until March 1902.

Viewed laterally, the ventral surface appears almost flat; the dorsal surface arched, more especially in the lumbar region, whence it tapers somewhat rapidly to the foot, projecting a short flap or tail over the cloaca.

Viewed dorsally, it shows a slight lateral compression.

The sub-prone face has the lips of the buccal orifice projecting almost as much as in *D. Hoodii*.

The lorica is of the type normal to the genus, with the dorsal and lateral clefts well marked.

The eye is situated on the dorsal side of the posterior extremity of the large brain-lobe. It consists of a saucer-shaped conglomeration of red pigment, in front of which appears usually one (sometimes a pair) of clear spheres such as are seen in *Proales* spp. (*Petromyzon*).

The foot is small and flexible, and carries the usual bunch of stiff setæ, which are, however, somewhat short.

The tail-like projection over the cloaca, so exaggerated in *D. sterea*, is present in this species to such a very small degree that it does not interfere with these setæ.

The toes, which are nearly straight blades (slightly upcurved), tapering to a sharp point, are very often carried over the back, one on each side of the dorsal cleft, as in the case of *D. eva*, cf. fig. 13a.

The food consists of flocculent matter.

The jaws have the incus short and stout, and clubbed at the fulcrum. The manubria are thin and tapering, and not crutched.

In habits this rotifer is a free and steady swimmer.

*Size*.—Total length  $1\frac{1}{8}$  in. to  $\frac{1}{2}\frac{1}{8}$  in. (140–110  $\mu$ ); toes alone  $7\frac{1}{10}$  in. (34  $\mu$ ); breadth  $\frac{1}{8}\frac{1}{10}$  in. (39  $\mu$ ); height  $\frac{1}{5}\frac{1}{8}$  in. (43  $\mu$ ).

*Habitat*.—Knowsley Park, Lancashire.

Uncommon, only found in small numbers.

The cervical eye places this species nearest to *D. Hoodii* and *D. ventripes*, from which, however, it may readily be distinguished by the following points:—

1. Its one or sometimes two lenses, if they are lenses.
2. Its almost straight, slightly upcurved toes.
3. Its slight lateral compression.

From *D. Hoodii* it is further distinguished by its thick, short incus; and from *D. ventripes* by its unbent shape of body, and terminal foot.

We have named this pretty and interesting species "*Derbyi*," in honour of the Right Hon. the Earl of Derby, K.G., as a slight recognition of his courtesy and kindness in permitting us to enter Knowsley Park, and to visit his ponds which we have found so prolific in rotifera.

Thus we have been enabled to collect very large numbers of



exceedingly rare and uncommon rotifers: e.g. we were the first to record *Ploesoma Hudsoni*, south of Scotland; and have added a new species *rostrata (nobis)* to the genus *Diglena*.

Hence also we have gained an intimate knowledge of this genus, having obtained there every species of *Diaschiza* mentioned in this monograph (except *D. tenuisetata*) and having added two new species to the genus, viz. "*ventripes*" and "*Derbyi*."

### *Diaschiza exigua* Gosse.

Pl. III. figs. 10 and 10a.

#### BIBLIOGRAPHY.

HUDSON & GOSSE.—The Rotifera. London, 1889, vol. ii. p. 78, pl. 22, fig. 13.

*Spec. Char.*—Body very small, wedge-shaped; head rather narrow from a dorsal view; neck well marked, specially deeply constricted on dorsum; face sub-prone; lorica flexible; dorsal cleft large, deep, more decided than usual; lateral cleft wide, deep, more decided than usual; eye cervical, large, double; foot small; toes about  $\frac{1}{3}$  length of rest of body, furcate, blade-shaped, slightly decurved.

In April 1901, we found great quantities of this minute *Diaschiza* in the large lake in Knowsley Park, Lancashire, and were able to make very careful observations.

Gosse's description is good; but the dorsal cleft is well marked and *deep*.

Viewed dorsally, the body tapers rapidly from the broad middle to almost a point above the very small foot. This gives it a wedge-shaped appearance, which may be taken as the most distinctive feature of the species.

There is a trace of a fleshy projection over the foot, as in *D. sterea*, but less conspicuous.

The eye, which is cervical, consists of two large hemispherical spots welded together inside the lower end of the brain-sac.

The setæ on the foot are well marked.

The toes taper evenly throughout, and are slightly decurved.

The jaws have the incus of moderate length, thick, and terminating in a small recurved bulb or fulcrum. The manubria are plain thin rods, not crutched.

Its food is flocculent matter.

*Size.*—Total length  $\frac{1}{260}$  in. (98  $\mu$ ); toes alone  $\frac{1}{1090}$  in. (23  $\mu$ ); breadth  $\frac{1}{800}$  in. (32  $\mu$ ); height  $\frac{1}{800}$  in. (32  $\mu$ ).

Common, but local.

*Diaschiza cæca* Gosse.

Pl. IV. figs. 11 and 11a.

## SYNONYMY.

1. *Furcularia cæca* Gosse.
2. *Furcularia ensifera* Gosse.
3. *Diaschiza pæta* Gosse.
4. *Diaschiza acronota* Gosse.

## BIBLIOGRAPHY.

- GOSSE, P. H.—Catalogue of Rotifera found in Britain. Ann. Nat. Hist., vol. viii. 1851, p. 197.
- HUDSON & GOSSE.—The Rotifera. London, 1889, vol. ii. p. 42, pl. 20, fig. 4; p. 43, pl. 20, fig. 3; p. 79, pl. 22, fig. 11; Suppl. p. 37, pl. 31, fig. 29.

*Spec. Char.*—Body long, more or less cylindrical, laterally compressed; head sub-conical; neck well marked; face sub-prone; corona extending right down to neck; lorica flexible; dorsal cleft well marked, deep; lateral cleft well marked, wide; eye wanting; foot short, thick; toes about  $\frac{2}{3}$  rest of body, furcate, style-shaped, acute, re-curved, wide apart at base; gastric glands in adult tinted red.

This *Diaschiza* is the first of the group which possesses no red eye, and is of the long, laterally compressed type. The lorica is very flexible, especially on the ventral surface, which is consequently sometimes flat, sometimes slightly concave.

The dorsal and lateral clefts are, in spite of this flexibility of the lorica, deep and well marked.

The foot projects considerably from under the lorica, and carries two toes *wide apart at their base* when viewed dorsally.

These toes are long, blade-shaped rods, with a fairly bold curve upward and outward.

The setæ on the foot, usually four, are very long in this species, often half as long as the toes.

The jaws have the incus long, the fulcrum large, and the manubria ending in a somewhat crutch-shaped club.

The adults have the gastric glands filled with red pigmented granules, which were mistaken by Gosse for a very large globose eye, hence he re-described this species as *D. pæta*.

They lie one on each side of an untinted, long brain-sac, which shows distinct cellular construction, but no vestige of an eye-spot.

In many young examples, which vary tremendously in size, all trace of the tint in the gastric glands is absent, and, in our opinion, it was from one of these immature examples that Gosse first described this species.

His description of *F. cæca* is correct as far as it goes.

We might add here that we are convinced that his single dead specimen (!) which he named *D. acronota*, was a dead *D. cæca*.

Again, in his description of what he calls *F. ensifera* he has evidently taken a larger specimen of *cæca*, in which the body has developed a greater gibbosity owing to its being an adult, and in which the foot, as is the case in mature specimens, has become less distinguishable from the trunk. But even in this case his specimens are not so large as some of ours.

It is only when he finds a really fully grown, fully developed specimen that he observed the dorsal cleft and red glands; he then re-described it as *D. pata*. But even in this description he falls into the grievous error of calling the pair of tinted gastric glands "a large cervical eye!"

We think it necessary to emphasise the extent of the variation in size of this species, as it might be easy to mistake some of these variations for new species. But it can always be identified by:—

1. The upcurved, outcurved, blade-shaped toes, wide apart at base.

2. The long brain-sac.

3. The formation of the jaws.

4. The absence of eye-spot.

This is one of the restless species, and is fond of swimming freely, as well as grovelling in the flocculent matter on which it feeds.

*Size of Adult*.— $\frac{1}{1\frac{1}{3}}$  in. (220  $\mu$ ); toes alone  $\frac{1}{4\frac{1}{80}}$  in. (53  $\mu$ ); greatest breadth  $\frac{1}{5\frac{1}{10}}$  in. (46  $\mu$ ); height  $\frac{1}{4\frac{1}{80}}$  in. (53  $\mu$ ). Common everywhere.

### *Diaschiza tenuior* Gosse.

Pl. IV. fig. 12.

#### BIBLIOGRAPHY.

HUDSON & GOSSE.—The Rotifera. London, 1889, vol. ii. p. 81, pl. 22, fig. 14.

*Spec. Char.*—Body almost cylindrical, hyaline; head same breadth as body; neck very lightly marked; face only slightly oblique; corona extending a very little way down ventral surface; lorica very flexible, and transparent; dorsal cleft well marked, deep; lateral cleft very wide indeed; no red eye, a transparent lens on the underpart of a large and long brain-sac; foot large, thick; toes about  $\frac{1}{4}$  length of rest of body, furcate, style-shaped, sharply pointed, straight; gastric glands sometimes tinted *brown*.

This interesting rotifer we consider to be one of the rarest of the *Diaschizæ*. We have very often found it, but only in single examples on each occasion. In this respect, with *D. globata*, it

differs remarkably in habit from the other species of the genus, which we have found almost in any quantity at each gathering.

Gosse's weak description of this rotifer makes it difficult to identify, but as he likens it to *D. gracilis*, we feel sure we have the species he described.

The jaws are certainly very like those of *gracilis*, except that the incus has a blunt broadish end, whereas in *gracilis* it ends in a point.

The hyaline appearance of the body, the width of the lateral cleft, the *straight* toes, and the want of pigmented eye, are sufficient to distinguish this easily from other *Diaschizæ*.

The body is almost cylindrical, very slightly gibbous, and showing just the least trace of lateral compression.

The venter is narrower than the dorsum.

The head, which is of the same width as the body, carries a ring or collar surrounding the corona, especially noticeable on the dorsal side, the extreme dorsal point projecting abruptly forward.

The face is sub-prone. The buccal orifice slightly protrudes. Above this is situated a bunch of stiff setæ.

Every example of this species which we have found has so far had a transparent lens on the lower part of a large brain-sac; but we do not consider this to be an essential mark of the species, as we have known it to vary exceedingly in size.

The stiffened integument ends abruptly a considerable distance in front of the base of the toes, which makes it difficult to determine foot from trunk. This, as already mentioned, is to some extent common to the whole genus, but is abnormally marked in this species.

The setæ on the foot are very long.

The toes are thin rods, and almost straight, the dorsal edge quite straight, the ventral tapering very slightly in an upward curve, and so producing, with the dorsal edge, a very sharp point. They are not wide apart at the base, nor so blade-shaped as in *D. cæca*. They are often thrown up over the back.

The stomach is sometimes tinted with food, but the whole animal has a remarkably hyaline appearance, which is one of the first features to strike one's notice.

#### EXPLANATION OF PLATE IV.

All figs.  $\times 476$ .

Fig. 11	—	<i>Diaschiza cæca</i>	Gosse.	Lateral view.	
" 11a	"	"	"	Dorsal view.	
" 12	"	<i>tenuior</i>	Gosse.	Lateral view.	
" 13	"	<i>Derbyi</i>	sp. n. Dixon-Nuttall and Freeman.	Lateral view.	
" 13a	"	"	"	Lateral view.	
" 13b	"	"	"	Dorsal view.	
" 14	"	? <i>megalcephala</i>	Glascott.	Lateral view.	
" 14a	"	"	"	Dorsal view.	

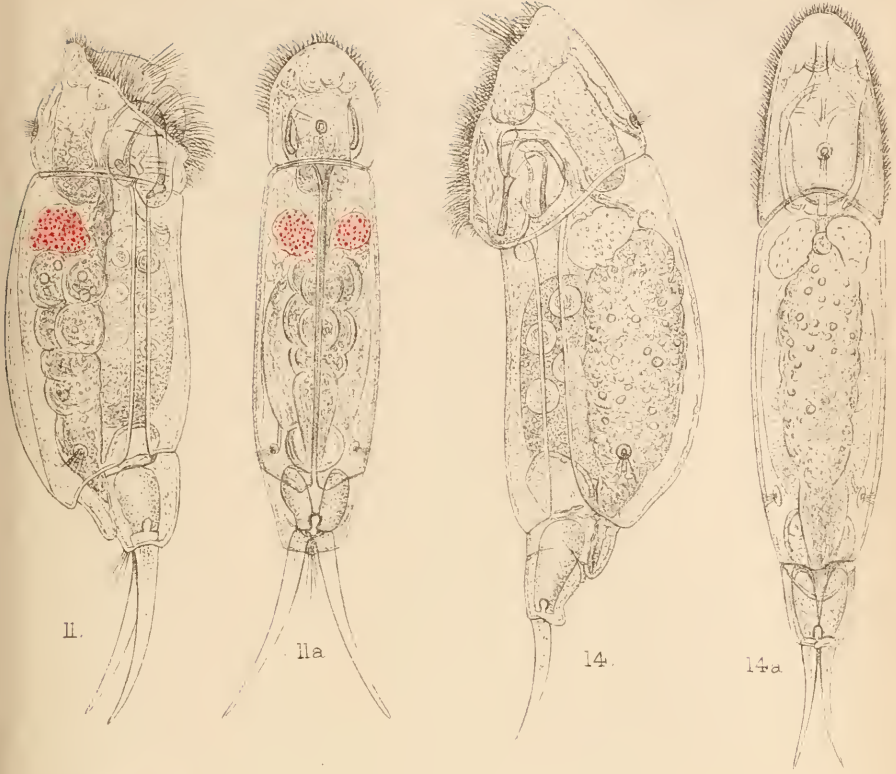

FR Dixon-Nuttall del. ad nat

West, Newman hth

Diaschizae.



The jaws are elementary; the manubria straight, thin, and rod-shaped, with a slight thickening at the end, but not a crutch. The incus is straight, also ending in a slight club.

It feeds on flocculent matter, and is fond of swimming freely.

*Size*.—Total length  $\frac{1}{131}$  in. ( $194 \mu$ ); toes alone  $\frac{1}{700}$  in. ( $36 \mu$ ); width  $\frac{1}{700}$  in. ( $36 \mu$ ); height  $\frac{1}{800}$  in. ( $42 \mu$ ).

Rare. Examples from Dundee, and Knowsley, Lancashire.

### *Diaschiza eva* Gosse.

Pl. III. figs. 8, *Sa*, *Sb*, *Sc*, *Sd*, *Se*.

#### SYNONYMY.

*Furcularia eva* Gosse.

„ *semisetifera* Glascott.

#### BIBLIOGRAPHY.

GOSSE, P. H.—Twenty-four more new Species of Rotif. Journ. Roy. Micr. Soc., 1887, p. 861.

HUDSON & GOSSE.—The Rotifera. London, 1889, Suppl., p. 26, pl. 31, fig. 17.

GLASCOTT, Miss L. S.—A list of some of the Rotif. of Ireland. Sci. Proc. Roy. Dublin Soc., viii. 1893 (n.s.) p. 55, pl. 4, figs. 2 and 2a.

*Spec. Char.*—Body long, laterally compressed; head slightly rounded in front; face sub-prone; corona extending slightly down the ventral side; neck strongly marked; lorica flexible; dorsal cleft narrow, well marked; lateral cleft narrow, well marked; eye absent; foot thick; toes about  $\frac{1}{2}$  length of rest of body, furcate, very wide apart at base, very broad, tapering suddenly to a long, fine, curved, threadlike point.

We have been exceedingly fortunate in finding large quantities of this most interesting and beautiful species, and have no doubt whatever that Gosse's description was made from a dying example, when the soft lorica often distorts into a prominent elevation on the shoulder, as described and drawn by him.

Owing to the well-marked dorsal and lateral clefts, and the setæ on the foot, we have no hesitation in transferring this species to the genus *Diaschiza*.

This rotifer is beautifully hyaline and glossy. It varies much in size and shape, the flexibility of the lorica enabling it to throw itself into all sorts of contortions.

When swimming freely many specimens, viewed dorsally, look exceedingly narrow. The greatest care has been taken in making the drawings to represent as nearly as possible the normal shape and attitude.

The toes are the most distinguishing feature of this species.

In spite of great variation in shape, length, and style, they are always strikingly distinct from those of any other species, in every

case consisting of a broad base rapidly tapering to a flexible thread-like tip.

Fig. 8 represents the commonest form of the toes, in which the blade widens before it begins to taper rapidly to the flexible thread.

Fig. 8a gives a dorsal view of the same form.

Fig. 8b represents a rare form, in which the broad base tapers gradually to the fine flexible thread. (This figure is greatly enlarged.)

Fig. 8c is a larger type of toe with remarkably long thread-tips.

Figs. 8d and 8e give the other extreme.

All these figures (except fig. 8b) are drawn to exactly the same scale, and from specimens as nearly of the same size as it is possible to select, so as to give a good idea of the amount of variation.

Gosse has graphically and accurately described one of the many attitudes which this rotifer strikes, viz. that of the letter T reversed, with the toes extended in a horizontal line. But it is impossible to describe all the different ways in which it fixes and curves its toes. At times it throws them right up on its back; at times it holds them at right angles to its body; and then again it presses them close together and straight behind it, for swimming.

Viewed dorsally, these toes are remarkably wide apart at the base.

The foot-glands are large, and, when under the compressor, are seen to exude a sticky substance which reminds one of that exuded by the Rattulidæ, though not so viscid in this case. This substance seems to make its exit from the toe at the point where it tapers rapidly to the flexible tip.

The usual setæ on the foot are exceedingly fine and difficult to determine, though after careful search we have found them in every case.

The eye is absent.

The food consists mainly of diatoms, numbers of which are often to be seen congesting the stomach.

The jaws are after the type of *D. gibba*.

*Size*.—Total length  $\frac{1}{90}$  in. (282  $\mu$ ); toes alone  $\frac{1}{380}$  in. to  $\frac{1}{300}$  in. (67–85  $\mu$ ); width  $\frac{1}{635}$  in. (40  $\mu$ ); height  $\frac{1}{424}$  in. (60  $\mu$ ).

Rare and local, but has occurred in vast quantities in the large lake, Knowsley, Lancashire.

### *Diaschiza tenuiseta* Burn.

Pl. I. fig. 2.

#### BIBLIOGRAPHY.

BURN, DR. W. B.—New and little known Rotif. Science Gossip, 1890, pp. 34, 35, fig. 22.

*Spec. Char.*—Body slightly gibbous, very glassy; face prone; neck a marked constriction; lorica very flexible; dorsal cleft well marked; lateral cleft well marked; eye wanting; foot rather long



for the genus, tapering; toes about  $\frac{7}{8}$  length of rest of body, very thin except just at base, very slightly recurved; œsophagus very long.

This uncommon species was observed by F.R.D.N. (one example only) on October 10, 1891; and a drawing was then made by him, of which fig. 2 is a copy.

The original description is given by Dr. Barnett Burn in the February number of *Science Gossip*, 1890.

From this description very little can be gathered; but from the drawing which accompanied it, the toes, the long œsophagus, and the trace of dorsal cleft there portrayed give just sufficient detail for identification.

The remarks upon its resemblance to *F. eva* and *F. cœca*, serve to make the identification more a matter of certainty.

We have every confidence, therefore, in classing this as a *Diaschiza*, from the general shape of body, foot and toes, and especially from the dorsal and lateral clefts well figured in F.R.D.N.'s original drawing.

The specific marks of this species are:—(1) the pair of very long thin toes, slightly clubbed at the base, but tapering at once, not at mid-length as in the case of *D. eva*, although they resemble those of *eva* in having flexible extremities; and (2) the extraordinarily long œsophagus.

This rotifer has the habit of throwing its toes over its back, and into some of the other postures characteristic of *D. eva*.

The setæ on the foot were not looked for.

The jaws, food, and size were not recorded.

Rare, not seen since 1891; from Mr. Bolton, Birmingham.

### *Diaschiza megalcephala* Glascott.

Pl. IV. figs. 14 and 14a.

#### SYNONYMY.

*Furcularia lactistes*? Gosse.

„ *megalcephala* Glascott.

#### BIBLIOGRAPHY.

- GLASCOTT, Miss L. S.—A list of some of the Rotifera of Ireland. *Sci. Proc. Roy. Dublin Soc.*, 1893, viii. (n.s.) p. 56, pl. 4, fig. 3.
- HOOD, J.—Rotif. of the Co. Mayo. *Proc. Roy. Irish Acad. Dublin*, 1895, p. 702.
- ROUSSELET, C. F.—On *Diplois trigona* and other Rotifers. *Journ. Quek. Micr. Club*, Nov. 1895, p. 123, pl. 7, fig. 5.
- GOSSE, P. H.?—Twenty-four more new Species of Rotif. *Journ. Roy. Micr. Soc.*, 1887, p. 861, pl. XIV. fig. 5.
- HUDSON & GOSSE?—The Rotifera. London, 1889, Suppl., p. 25, pl. 31, fig. 13.

We are strongly of opinion that this is not a *Diaschiza* at all; but out of respect to Mr. C. F. Rousselet we include it in our list.

(1) We have carefully studied countless examples of this rotifer, and have never been able to discern the dorsal cleft which he states (loc. cit.) that he observed.

(2) Nor have we ever been able to discover the slightest trace of the bunch of stiff setæ on the foot over the base of the toes, which is invariably present in other *Diaschizæ*.

(3) Furthermore, there is a marked division in the foot, forming two distinct joints, which is contrary to the rule in this genus. There certainly is a lateral cleft, but this is the only point of agreement between this species and our genus.

(4) In its habits it is continually swimming freely, and not, like the *Diaschizæ*, given to grovelling amongst the weeds.

(5) Its toes are flexible throughout, and it has a queer habit of snapping them as it swims.

(6) The head is enormously large, the longer axis of the face being even greater than the greatest depth of the rest of the body.

(7) The jaws are extraordinary in form and structure, and not of the type of this genus; (8) and again, the lorica as a whole is much more flexible than that of the most flexible *Diaschiza*.

These eight points of difference are sufficient to account for our hesitation in including this species in this monograph.

We agree with Mr. J. Hood (loc. cit.) that this species is most probably the *Furcularia lactistes* of Gosse, a great many examples showing a distinct milky appearance, from which we expect he so named it, and the jaws agree with his description.

We give a figure of the animal, which will convey a sufficient idea of it without further description.

*Size*.—Total length  $\frac{1}{127}$  in. (200  $\mu$ ); toes alone  $\frac{1}{765}$  in. (33  $\mu$ ); breadth  $\frac{1}{380}$  in. (67  $\mu$ ); height at highest point of trunk  $\frac{1}{470}$  in. (54  $\mu$ ); head  $\frac{1}{400}$  in. (63  $\mu$ ).

Common in certain localities.

The following is a list of species described by other authors which are omitted from this monograph or proved to be synonymous with others herein:—

D. VALGA Gosse.—The description, drawing, and measurements of this species, with its very long toes, two-thirds the length of the rest of the body, seem so definitely distinct from any of those here included, that it may be a good species; but we have omitted it, as we have been unable to secure a specimen.

D. VALGA Bilfinger  
D. VALGA Weber  
D. RAMPHIGERA Gosse } = *D. Hoodii* Gosse.

D. CUPHA Gosse.—That author's description, from one dead specimen, is so vague, and the size  $\frac{1}{24}$  in., and shape of toes, seem to cut it out of this genus altogether. Not seen.

D. FRETALIS Gosse.—Another very vague description. This species, being marine, may be a marine form of *D. Hoodii*.

D. ACRONOTA Gosse  
D. PÆTA Gosse  
FURCULARIA ENSIFERA Gosse } All these are certainly immature or dead specimens of *D. cæca* Gosse.

D. SEMIAPERTA Gosse = *D. gibba* (nobis) = *F. gibba* Ehrenberg.

F. SPHÆRICA Gosse = *D. globata* Gosse.

F. LOPHYRA Gosse.—This may be a fair species, and if so, it is a *Diaschiza*; its frontal eye will distinguish it from *D. eva*, but the description is very vague.

F. GAMMARI Plate  
F. MELANDOCUS Gosse  
F. MOLARIS Gosse } The description of all these species is far too vague for identification.

F. LACTISTES Gosse.—This description is, again, a difficult one from which to identify. It has a certain agreement with *D. megalcephala* Glascott, which we have inserted in the monograph under protest.

It is very likely that a new genus may one day be established in which it is probable that *lactistes* will take precedence over Miss Glascott's *Furcularia megalcephala*.

III.—*The President's Address: Some Ideas on Life.*

By HENRY WOODWARD, LL.D. F.R.S.

*(Delivered January 21st, 1903.)*

THOSE who have in infancy been properly nurtured on a wholesome diet of fairy tales and folk-lore, will carry with them through life, even to old-age, many very pleasant memories of those delightful friends of one's childhood, 'Beauty and the Beast,' 'Cinderella,' 'Little Red Riding-hood,' 'Jack the Giant-killer,' 'Sleeping Beauty,' 'Blue Beard,' and many others; or if they belong to a later generation than myself, they will in early life have been on intimate terms with 'Tom the Water-Baby,' in Kingsley's wonderful book; or will feel, as most of us do, grateful to "Lewis Carroll" (L. Dodgson) for having written 'Alice in Wonderland' and "Through the Looking-glass," for our delectation. Pleasant indeed are such memories,—like the scent of heather from the hills,—or "the odour of brine from the ocean."

On Christmas holidays, in passing along the High Street of the Royal Borough of Kensington, I was startled by a shrill familiar voice from out the distant past, and suddenly, for a few moments, I had sixty years lifted off my shoulders and became once more a child at a school-room window in Norwich, looking on with large eyes at the ineffable effrontery of Mr. Punch encountering the constable, and filled with admiration at the courage and fidelity of his dog Toby.

Perhaps the oldest themes, which are to be found broidered into the later history, legends, and traditions of all races of mankind, are those which relate to the creation of the world and its inhabitants, and their destruction by the flood.

Apart from the sacred writings of the Hebrews, we have Assyrian tablets and Egyptian hieroglyphs, while the Greeks have given us in charming fables, and in many versions, the account of Prometheus forming men of clay and stealing fire from the chariot of the sun to endow them with life; of Deucalion and Pyrrha rescued from the flood, and afterwards renewing the human race by throwing stones behind them which became men; of Epimetheus and his wife Pandora, and the story of the sealed box, which she was forbidden to open, and how the curiosity of Pandora caused her to raise the lid, when all the evils incident to humanity poured out, and the only good remaining was Hope, which has been the solace of mankind ever since.

But leaving the regions of classical and mediæval myths, and even passing over unnoticed the earlier writers and philosophers—whose observations, although often very good, ended frequently in the fabulous and mysterious, or were intermingled with gross errors resulting from ignorance of astronomical laws and cosmical and chemical effects—we come, in 1669, to the observations of *Steno*, a professor of the Padua University, who compared fossil shells with recent, and showed that the two were often specifically the same—that sharks' teeth from the hills of Rome were like those of a shark now living in the Mediterranean.

The eighteenth century gave birth to many able philosophers and also to many writers having a distorted vision resulting from a firm belief in the *literal acceptance* of the Mosaic cosmogony, into which they constrained their facts and observations to fit.

Gesner, a Swiss observer, in 1759, demonstrated, by comparing past physical changes with those now in progress, that elevation of mountains and the wearing away of ravines and valleys must have occupied tens of thousands of years to accomplish.

[1665–1729.] *Dr. John Woodward* insisted on the theory that all deposits resulted from the Noachian deluge, and that their materials and fossil-contents were arranged by *gravitation*, the heaviest at the bottom. He did one excellent thing, he founded in Cambridge the Woodwardian chair of geology, which has now become a great centre for the teaching of modern geology, but was originally designed to ensure the delivery of a sermon annually, to confound the doctrines of *Dr. Camerarius* of Tübingen and all his works, because he differed from the views of *Dr. Woodward*.

Some of the writings of the Italian naturalists at this time were most brilliant and advanced, but the lack of frequent intercommunication between men of science 150 years ago prevented the wide spread of intellectual ideas.

Amongst the most able writers in this country (1726–1797) was *James Hutton* of Edinburgh, whose *Theory of the Earth &c.* was the foundation of *Lyell's Principles of Geology* and many other later writings. His views, based on observations, were clear and convincing to all studious minds:—

“The ruins of an older world are visible in the present structure of our planet; and the strata which now compose our continents have been once beneath the sea, and were formed out of the waste of pre-existing continents. The same forces are still destroying, by chemical decomposition or mechanical violence, even the hardest rocks, and transporting the materials to the sea, where they are spread out and form new strata analogous to those of more ancient date. Although loosely deposited along the bottom of the ocean, they become afterwards altered and consolidated by volcanic heat, and then heaved up fractured and contorted.”

In WILLIAM SMITH (1769–1839) we have a man of humble origin, born at Churchill in Oxfordshire, who, by force of will and industry, trained himself and became a mineral surveyor and geologist of no mean order. He not only mapped out the geology of England and Wales in a most admirable manner, but discovered a great and original principle, which has stood the test of over 100 years of subsequent geological field-work, namely, that the relative age of sedimentary deposits can be determined with certainty by their organised fossil-contents. This principle, which he was able to prove to demonstration over wide areas and in hundreds of instances, together with the excellent map which he produced, obtained for him from Sedgwick the title of "*Father of English Geology.*" Had William Smith been as able a writer as he was a brilliant observer in the field and mapper, his fame would have been more widely known than it is. One of his geological contemporaries was Samuel Woodward\* of Norwich (1790–1837). Suffice it to say that with a succession of men like Sedgwick, Conybeare, Buckland, Phillips, Murchison, Lyell, Scrope, Fitton, de la Beche, Griffiths, Portlock, Prestwich, Ramsay, Geikie, geology has progressed enormously in the past 100 years, and is now one of the most popular sciences of the day.

From the birth of orderly stratigraphical geology has arisen the cognate science of *Palæontology* which treats of all fossil remains, and takes note of their succession in the rocks as well as their zoological position among living organisms.

But since the publication of Darwin's *Origin of Species*, now forty years ago, a new and ardent school of zoologists and botanists have entered the field of palæontology, who,—whilst they ignore entirely the advantage which the stratigraphical geologist derives from fossils, looked at from the chronological aspect,—are nevertheless eager to possess themselves of the *palæozoological evidence* they furnish, which is in fact the key to open the lock of the casket that holds the secret of the origin of species, and even, they believe, of the beginning of life on the earth—a secret they are as eager to learn, as that for which our first mother Eve bartered Paradise, or that which excited the curiosity of the Greek Pandora, or the unhappy wives of Bluebeard.

Although I may not deceive you with promises to disclose the very beginning of life, I may at least be able so far to lift the lid of the casket as to give you a *glance* at some of the earliest appearances of groups of living organisms, and point out a few which have persisted over vast periods of time, and others which, though of great importance at one time (like some of our celebrated human families), have now entirely disappeared.

\* Author of a work entitled 'Outline of the Geology of Norfolk,' 1833, and 'A Synoptical Table of British Organic Remains,' 1830, and about thirty other memoirs and works.

While upon the subject of the evolution and extinction of life-forms I may be permitted to refer you to a very able paper which has lately appeared,\* by Mr. C. B. Crampton, on this subject.

*To-night* I will only venture to glance at some of the INVERTEBRATA; leaving the VERTEBRATA to be discussed upon another occasion.

"In the first place (Mr. Crampton writes) the lowly-organised groups have persisted in spite of the gradual evolution of more and more highly-organised forms, and this must be due in large measure to their rapid growth and reproductive powers.

(2) That groups appear to have a shorter range in time as they acquire a higher degree of organisation.

(3) That living forms of groups that are dominant at the present time rarely show ancestors of such great specialisation as themselves.

(4) That forms that are now isolated in their zoological affinities, and bordering on extinction, are generally highly specialised in some direction, but often show signs of degeneration, and usually have ancestors of greater specialisation during some former period of dominance. A few, at any rate, seem to show a smaller degree of fertility than might be expected.

(5) Other forms which have come down to us from a distant period with small amount of change, or with very gradually-acquired specialisation, often show a great power of resistance to death. They are also generally extremely fertile.

(6) That extinct groups seem almost invariably to have acquired a great degree of specialisation during their period of dominance.

(7) That the more specialised genera and species of groups tend to have a shorter range in time than the less specialised, although they frequently appear to have temporarily acquired a greater dominance.

(8) When a group shows very quickly-acquired variation and specialisation its range is usually very restricted.

(9) That the later forms in extinct groups frequently show signs of degeneration, and sometimes a more primitive organisation than the most specialised forms, possibly owing their persistence to their slower specialisation.

(10) That long retention of primitive characteristics, or a great degree of stability and want of variation, has been usually associated with a long range in time.

(11) That higher groups do not spring from the most specialised forms of the parent groups before them in time, but from some generalised form in those groups which had retained a more primitive organisation."

\* Proc. Roy. Phys. Soc. Edin., xiv. p. 461; read March 20th, 1901.

## TABLE OF STRATIFIED ROCKS.

*Showing the range in time of the great groups of Animals, and the period during which each type was dominant.*

Periods.	SYSTEMS.	FORMATIONS.	LIFE-PERIODS.
Quaternary.	<b>RECENT</b>	Terrestrial, Alluvial, Estuarine, and Marine Beds of Historic, Iron, Bronze, and Neolithic Ages	Dominant type, Man.
	<b>PLEISTOCENE</b> (250 ft.)	Peat, Alluvium, Loess Valley Gravels, Brickearths Cave-deposits Raised Beaches Palæolithic Age Boulder Clay and Gravels	
Tertiary.	<b>PLIOCENE</b> (100 ft.)	Norfolk Forest-bed Series Norwich and Red Craggs Coralline Crag (Diestian)	Dominant types, Birds and Mammals.
	<b>MIOCENE</b> (125 ft.)	Eningen Beds Freshwater, &c.	
	<b>EOCENE</b> (2600 ft.)	Fluvio-marine Series (Oligocene) Bigshot Beds } (Nummulitic Beds) London Tertiaries }	
SECONDARY or MESOZOIC.	<b>CRETACEOUS</b> (7000 ft.)	Maestricht Beds Chalk Upper Greensand Gault Lower Greensand Wealden	Dominant type, Reptilia.
	<b>NEOCOMIAN</b>		
	<b>JURASSIC</b> (3000 ft.)	Purbeck Beds Portland Beds Kimmeridge Clay (Solenhofen Beds) Corallian Beds Oxford Clay Great Oolite Series Inferior Oolite Series Lias	
	<b>TRIASSIC</b> (3000 ft.)	Rhætic Beds Keuper Muschelkalk Bunter	
	<b>PERMIAN or DYAS</b> (500 to 3000 ft.)	Red Sandstone, Marl Magnesian Limestone, &c. } Zechstein Red Sandstone and Conglomerate Rothliegende	
PRIMARY or PALÆOZOIC.	<b>CARBONIFEROUS</b> (12,000 ft.)	Coal Measures and Mill-tone Grit Carboniferous Limestone Series	Dominant Type, Fishes.
	<b>DEVONIAN &amp; OLD RED SANDSTONE</b> (5000 to 10,000 ft.)	Upper Old Red Sandstone Devonian Lower Old Red Sandstone	Dominant Type, Fishes.
	<b>SILURIAN</b> (3000 to 5000 ft.)	Ludlow Series Wenlock Series Llandovery Series May Hill Series	Dominant type, Invertebrata.
	<b>ORDOVICIAN</b> (5000 to 8000 ft.)	Bala and Caradoc Series Llanefello Series Llanvirn Series Arenig and Skiddaw Series Tremadoc Slates Lingula Flage Menevian Series Harlech and Longmynd Series	
	<b>CAMBRIAN</b> (20,000 to 30,000 ft.)		
	<b>EOZOIC—ARCHÆAN</b> (30,000 ft.)	Pebldian, Arvonian, and Dimetian Huronian and Laurentian	

Range of Invertebrata and Plants in time.

Range of Fishes in time.

Range of Reptilia in time.

Footprints of Birds ?—Range of Birds in time.

Range of Mammalia in time.



And I would add lastly :—

That those forms which have persisted through long past periods of geological time, have also an extremely wide geographical distribution at the present day. I illustrate this by a diagram (fig. 34).

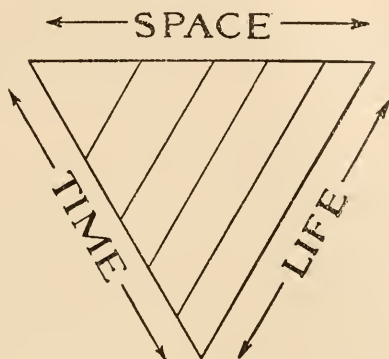

FIG. 34.

As might naturally be expected, it is the *lowly-organised* forms which show the longest geological history.

### I. PROTOZOA.

RADIOLARIA are found throughout the whole geological series and are world-wide in their distribution.

Of the FORAMINIFERA, about two-thirds out of 2000 species occur fossil. The longevity of some genera is truly remarkable, e.g. *Lagena*, *Nodosaria*, *Textularia*. The first two range from Silurian, and the last from Carboniferous times to the present day. *Fusulina* and *Schwagerina* are world-wide in their distribution in Carboniferous time, forming entire beds of limestone. (They are, however, confined to the Carboniferous.)

Several giant species of *Nummulina* occur in early Tertiary times.

### II. PORIFERA (THE SPONGES).

The *Lithistid* and *Hexactinellid* SPONGES have existed since Cambrian times. The *Calcispongiæ* appear in late Palæozoic times and only become important in the Mesozoic period.

### III. CŒLEENTERATA :—I. HYDROZOA.

The GRAPTOLITES are world-wide in their distribution in early Palæozoic time ; they are enormously abundant and varied, and

disappear at the end of the Silurian period. *Dictyonema*, a doubtful Graptolite, extends from the Cambrian to the Devonian.

### III. CŒLEENTERATA:—II. ANTHOZOA.

Of the CORALS, the Rugose and Tabulate corals are confined to the Palæozoic rocks.

The *Hexacoralla* are first seen in the Trias and continue to the present day. *Zaphrentis*, *Petraia*, *Clisiophyllum* and *Strephodes*, all simple types of Rugose corals, range from the Silurian to the Carboniferous age.

The same range is found for *Cyathophyllum* and *Diphyphyllum*, both of which are compound forms.

Of the *Hexacoralla*, four genera range from Jurassic to Recent.

Of the *Tabulate* corals (among the RUGOSA), *Favosites* and *Syringopora* range from Silurian to Carboniferous times.

The existing corals belong to the MADREPORARIA, the FUNGIDA, and PERFORATA, and have no palæozoic representatives, but the Secondary and Tertiary deposits have yielded a large number of these forms. The composite *Madrepora* include a vast number of forms and range from the Eocene to the present day.

### IV. ECHINODERMA.

Of the ECHINODERMA, the extinct groups the CYSTOIDS and BLASTOIDS only lived in the Palæozoic period.

Of Cystoids, 50 genera and 250 species are known, and

Of Blastoids, 19 genera and 120 species are recorded.

The CRINOIDS appear to have declined ever since their maximum development in Palæozoic times.

*Ichthyocrinus* ranges from the Ordovician to the Carboniferous.

*Taxocrinus* has the same range.

Of later forms, *Pentacrinus*, *Estracrinus*, and *Antedon* have persisted from the beginning of the Mesozoic period with very little change.

STARFISHES range from the Cambrian to the present day.

ECHINOIDS: regular forms like *Cidaris* have existed since the Trias.

*Echinocorys* and some other irregular forms appear in the Cretaceous, but many of the genera quickly became extinct. But both regular and irregular forms have continued on to the present time.

### V. POLYZOA ("SEA-MATS").

The POLYZOA date back to the Ordovician.

Of CYCLOSTOMATA, *Stromatopora* and *Berenicea* range through the whole time to Ordovician.

Many living genera range back into Mesozoic times.

The MONTICULIPORIDS, a peculiar group, perhaps related to the POLYZOA, were dominant in Ordovician and Silurian times, but doubtfully survived the Palæozoic period.

Of the CRYPTOSTOMATA, such genera as *Fenestella*, *Polypora*, *Rhabdomeson*, and their allies are Palæozoic.

The CHILOSTOMATA, forming the bulk of living Polyzoa, date back to the Jurassic period.

## VI. BRACHIOPODA.

The BRACHIOPODA have their maximum development in Palæozoic times. *Productus*, *Spirifer*, *Pentamerus*, *Cyrtia*, *Merista*, *Uncites*, and *Stringocephalus* show not only great abundance and extraordinary specialisation of forms, but also remarkable variety of shape, size, and condition of their brachial supports. They have a comparatively short range in time, both in genera and species.

The long-winged Spirifers, dominant in the Devonian, were rapidly extinguished, but the simple *Spirifer glabra* ranges from the Devonian into the Carboniferous. Any striking peculiarity of growth or size seems to be followed by rapid extinction.

In the Mesozoic period both genera and species are much reduced in numbers, the forms chiefly belonging to the persistent *Terebratula* and *Rhynchonella* types, with slight variations in their shell markings.

With these are some exceptional forms, such as *Lyra*, *Magas*, *Kingena*, *Trigonosemus*—strictly Cretaceous, while a few others as *Pygope*, *Dietyothyris* (specialised *Terebratulæ*), have a limited range in the Jurassic period.

From the Lower Palæozoic period genera like *Lingula*, *Crania*, and *Discina* have continued on, and are living now. Such forms may be truly termed persistent types.

In this division hermaphroditism (so rare in this class) occurs.

*Lingula* shows great resistance to death, surviving after being out of water and in a dry condition for some time.

## VII. VERMES (WORMS).

Worms being all *soft-bodied animals* are seldom found in a fossil state. Their former existence is, however, proved by their tracks, burrows, and castings which they have left in the sedimentary rocks from the Cambrian to the present day. Their chitinous teeth and jaws have been exhibited by Dr. Hinde, F.R.S., before this Society and described and figured in the Quart. Journ. Geol. Soc., London, 1879, 1880, and in the Transactions of the Royal Swedish Academy.

Many species construct tubes. These variously formed cases (called *Serpulæ*) are common in many formations, but do not disclose much information about the structure of the animal itself.

They admirably illustrate the persistence *in time* of very simple and lowly organised forms, having bodies composed of a large number of similar segments (often capable of subdivision), and possessing moreover great powers of reparation and reproduction and resistance to death.

### VIII. MOLLUSCA.

In the MOLLUSCA, amongst the LAMELLIBRANCHIATA, there are many persistent types showing very small amount of variation.

E.g. *Solenomya* has persisted since Carboniferous times, and *Nucula* from the Silurian onwards. Both belong to the "*Protobranchiata*" forms, with simple gills and a sole on the foot for creeping upon—not a mere digging foot.

In contrast to these are the Rudistes, such as *Diceras*, Upper Jurassic; *Requienia*, *Monopleura*, *Caprina*, *Sphærulites*, and *Hippurites*, &c., from the Cretaceous. These peculiar Molluscs had a world-wide distribution, and occur in such numbers that beds of limestone are often built up of their shells. *Chama*, which represents them, has continued to the present day, but is less specialised.

*Trigonia* is not only a persistent genus, but exhibits great resistance to extreme variation, save in minor matters of shell-ornament. It ranges from the Trias to recent, and has a world-wide distribution. There are three species living in Australia and at least 100 species extinct.

In the SCAPHOPODA the curious *tubular* genus *Dentalium* ranges from the Ordovician to the present day. There are many species, but little variation from the type.

The multivalve *Chitons* extend also from Ordovician times to the present, but are never common in a fossil state. Only 70 species have been described from all known horizons. They are more abundant in modern seas, more than 200 species being now living.

The PTEROPODS (proper) only date back to the Cretaceous.

The earlier forms known as *Tentaculites*, *Hyolithes*, *Conularia*, are very doubtfully related to the Pteropoda. We have *Tentaculites* in Silurian and Devonian rocks; *Hyolithes*, Cambrian to Permian; and *Conularia*, from Ordovician to Lias; both the latter are very persistent types.

In the MOLLUSCA—GASTEROPODA—*Patella*-like forms have existed from early Palæozoic times. Walcott has figured 6 species of *Scenella*, 8 species or varieties of *Stenotheca*, and 1 of *Platyceras*

from the Lower Cambrian of North America. *Capulus* has persisted from Cambrian times to the present day.

The remarkable genus *Pleurotomaria* also ranges from Cambrian to recent, living in Japan and in the West Indies, and is represented by 4 or 5 species recent; 11 Tertiary; 575 Secondary; and 570 Palæozoic forms.

The *Nerincidæ* are very specialised shells in the structure of the columella; their range is also very brief. There are 150 species recorded from Mesozoic strata.

The PULMONIFERA, Land-Snails range from the Coal Measures to recent.

Among the CEPHALOPODA, the *Nautiloid* type is remarkable for its persistence since Cambrian times. Many specialised forms, showing extreme variety of growth and shell-structure, have branched out from this stock during its dominance in Palæozoic times, but these have in turn all died out.

Of these, the simple genus *Orthoceras*, with its long straight shell, had the greatest range, viz. from the Cambrian to the Trias; the other modifications have also fairly long ranges and show remarkable varieties of shell-structure.

The *Ammonites*, which range from the Trias to the Chalk, show almost endless variety in shell-ornament within certain limits, and have a world-wide range in Jurassic times branching out into more than 600 species.

In the Cretaceous period (before their disappearance) they put on most singular and remarkable developments of shell-variation, *Crioceras*, *Scaphites*, *Ancyloceras*, *Helicoceras*, *Toxoceras*, *Baculites*, *Ptychoceras*, *Hamites*, *Turrilites*, then they disappear entirely. We do not know the animal in *Ammonites*.

The *Belemnitidæ* range from the Trias to the Cretaceous.

The guard in most genera is large and dense, whilst the chambered portion or "phragmocone," is small and rudimentary. But *Aulacoceras* of the Trias has a large phragmocone and the guard quite small.

The Belemnites appear to have been gregarious (like their modern congeners the "Squids"), entire beds in the Lias being composed of their guards at Whitby, Yorkshire, Lyme, in Dorsetshire, and other localities in the central counties. More than 100 species have been described.

Possibly *Spirulirostra*, of the Tertiaries, and the recent *Spirula* may be survivors which have gradually dispensed with the guard to the shell, so characteristic of the Belemnites proper.\*

The following table shows the range of the Arthropoda in time.

\* I am desirous to mention here that for the above summary, from the PROTOZOA to the MOLLUSCA, I have largely made use of Mr. C. B. Crampton's statistics with some modifications from my own notes and other sources of information.—H. W.

## IX. ARTHROPODA.

## A. Crustacea.

## I. ENTOMOSTRACA. 1. BRANCHIOFODA.

- Order 1. PHYLLOPODA.  
*Apus* . . . . . Cambrian to recent.
2. PHYLLOCARIDA.  
*Hymenocaris*,  
*Ceratiocaris (Nebalia \*)* . . . . . Ditto.  
*Estheria* . . . . . Devonian to recent.  
*Cheirocephalus* . . . . . Tertiary to recent  
(Fresh-water).  
*Artemia* . . . . . Ditto (saline).
3. CLADOCERA.  
*Daphnia* and its allies . . . . . Probably all recent.  
(The *Ephippia* winter eggs of *Daphnia* have been found fossil in  
the Forest Bed series of Norfolk.)
4. OSTRACODA.  
*Cypris*, *Candona*, *Cythere*, &c. . . . . Palæozoic to recent.
5. COPEPODA.  
*Cyclops*, &c. . . . . Not found fossil.  
Many other families are not represented in a fossil state.

## II. MALACOSTRACA.

1. PODOPTHALMA.  
*Brachyura* . . . . . Jurassic to recent.  
*Macrura* . . . . . Carboniferous to recent.  
*Schizopoda* . . . . . Ditto (*Palæocaris*).  
*Stomapoda* . . . . . Devonian or Silurian to  
recent.
2. EDRIOPHTHALMA.  
*Cumacea* . . . . . Carboniferous to recent.  
*Isopoda* . . . . . Magn. L. to recent.  
*Præarcturus* . . . . . Devonian?  
*Amphipoda* . . . . . Carboniferous?

## III. GIGANTOSTRACA Haeckel.

- TRILOBITA . . . . . Cambrian to Carboniferous.  
MEROSTOMATA.  
*Furypterida* . . . . . Ditto.  
*Xiphosura* . . . . . Silurian to recent.

## IV. CIRRIPIEDIA.

- (Scissile)  
*Balanidæ (Brachylepas)* . . . . . Cretaceous to recent.  
(Pedunculated)  
*Lepadidæ (Turrilepas)* . . . . . Silurian to recent.

## SCORPIONIDÆ. B. Arachnida.

- (Scorpius) . . . . . Silurian to recent;  
world-wide distribution.  
*Palæophonus* . . . . . U. Sil., Scotland, Gotland,  
and Illinois, U.S.  
*Eophrynus* . . . . . Carboniferous only.

## C. Myriopoda.

- Eupholeria* and allies . . . . . Coal-measures to recent.

## D. Insecta.

- Palæodictyoptera*.  
*Blatta* . . . . . (Silurian?) to recent.  
*Eugereon*, etc. . . . . Permian to recent.  
Orthoptera . . . . . Coal-measures to recent.  
Neuroptera . . . . . Coal-measures to recent.

\* Recent analogue. Probable progenitor of Decapoda.

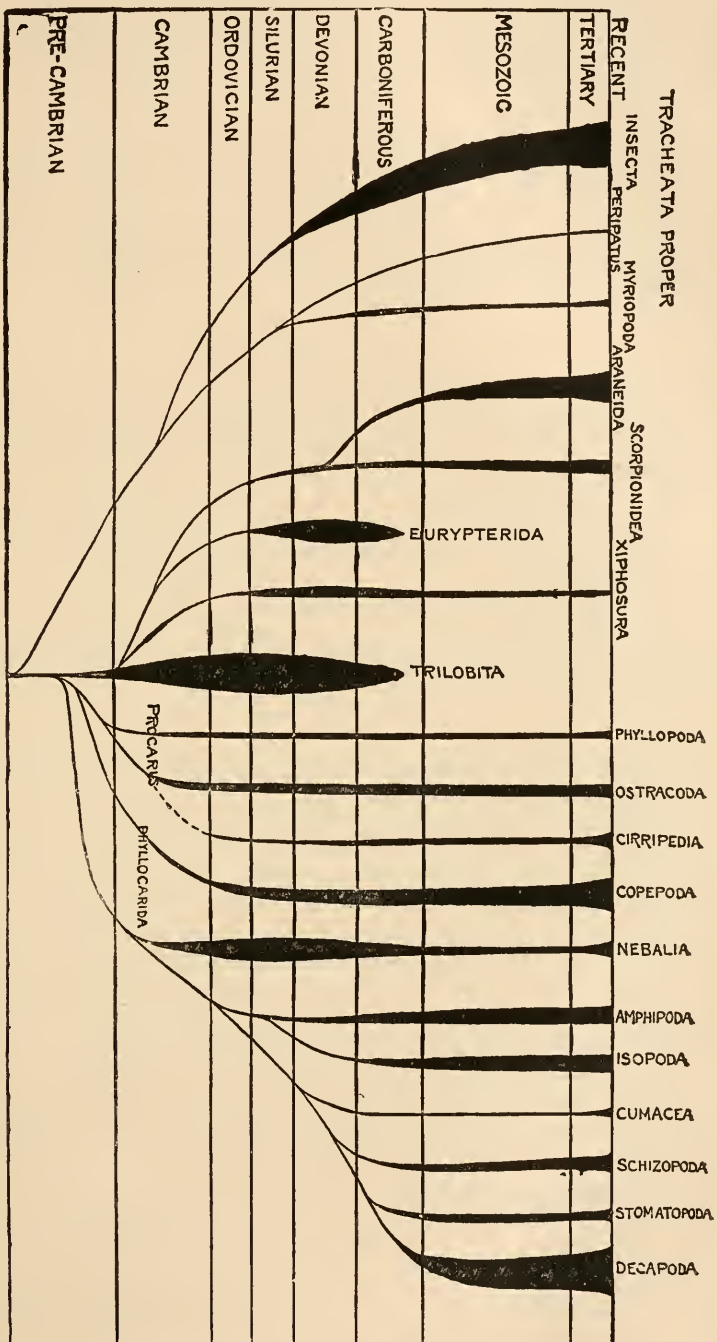

Fig. 35.—THE EVOLUTION OF THE ARTHROPODA IN GEOLOGICAL TIME.

The diagram (fig. 35) on the preceding page (p. 153) is intended to convey an idea of the probable evolution of the Arthropoda in geological time.

#### Summary.

And now, "let us hear the conclusion of the whole matter."

The whole history, since the beginning of life on the earth, shows a steady upward tendency (in fact **Evolution**) in life as displayed in the Geological Record.

#### Extinct Groups.

Some forms appear, attain a more or less important position on Life's Stage, and then die out completely.

Of such are the once abundant **Graptolites**, which had their beginning in the Cambrian, their maximum in the Ordovician and Silurian, and then disappeared.

The **Trilobites**, which began in the Cambrian, attained their maximum in the Silurian, lived on into Carboniferous times, and then disappeared.

The **Merostomata** (*Pterygotus*, *Eurypterus*, *Stylonurus*, &c.) began in the Silurian, attained their maximum, lived on into the Devonian and Carboniferous periods, and then became extinct.

#### Persistent Groups.

Again we have *persistent forms* of which we seem to see neither the beginning nor the ending.

Of these we may name the **Protozoa**, embracing the **RADIOLARIA** and the **FORAMINIFERA**, both persistent in rocks of all ages and well represented at the present day.

The **Porifera** (Sponges) which, though materially differentiated in the course of geological ages, have lived on till to-day.

The **CRINOIDEA** (Sea-lilies), represented from Silurian times to the present day, but not nearly so abundant as in Palæozoic times.

The **STARFISHES** (**Asteroidea** and **Ophiuroidea**), both persistent types from Silurian (or earlier) times to the present.

The **Annelida** again are met with in all strata and also living.

The **Brachiopoda**, beginning in the Cambrian, enormously developed in Silurian, Devonian, Carboniferous, and Secondary deposits, and still surviving in diminished numbers in modern seas.

**Mollusca**, represented in past time by the persistence of

<i>Lamellibranchiata</i>	. . . . .	Cambrian to recent.
<i>Sraphopoda</i>	. . . . .	Cambrian? to recent.
<i>Chitonidæ</i>	. . . . .	Silurian to recent.
<i>Pteropoda</i>	. . . . .	Cretaceous to recent.
<i>Prosobranchiata</i>	. . . . .	Cambrian? to recent.
<i>Cephalopoda</i> (in part)	. . . . .	Ordovician to recent.
<i>Pulmonifera</i> (Zonites and Pupa)	. . . . .	Coal-measures to recent.



The **Crustacea**, represented in past time by persistent forms such as the

ENTOMOSTRACA—

<i>Ostracoda</i> . . . . .	Cambrian to recent.
<i>Phyllocarida</i> . . . . .	" "
( <i>Xiphosura</i> ) <i>Limulus</i> . . . . .	Silurian to recent.

The **Arachnida**.

Scorpionidæ (Scorpio) . . . . .	Silurian to present day.
---------------------------------	--------------------------

The **Myriopoda** . . . . .

Coal-measures to recent.

The **Insecta**.

Neuroptera . . . . .	Coal-measures to recent.
Orthoptera . . . . .	" "
Thysanura . . . . .	" "
Homoptera . . . . .	" "

Of Newer Groups.

The following groups which have appeared in newer geological time may be cited—

The <i>Bryozoa</i> . . . . .	from Carboniferous to recent.
The <i>Echinoidea</i> , or "Sea-urchins" . . . . .	" "
The <i>Pteropoda</i> (proper) . . . . .	" "
The <i>Gasteropoda</i> . . . . .	" "
The <i>Decapoda</i> . . . . .	" "
The <i>Isopoda</i> , &c. . . . .	" "

And the great mass of *living Insects*, from the Secondary to recent.

The Range in time of the principal groups of the Invertebrata is given in a diagram form on p. 156, showing the Persistent groups (P.), the Extinct groups (E.), and the comparatively Modern groups (M.).

If we except such groups as the Crinoids, the Brachiopods, the Nautilidæ, the Xiphosura—which evidently attained their *greatest maximum in the past*, and although still surviving are now but a feeble folk—we shall notice that the modern Echinoids, Bryozoa, Mollusca, Gasteropoda (Siphonostomata and Pulmonifera); the higher Crustacea (Decapoda, Brachyura, and Macrura) the Isopoda, Stomapoda, &c.; and our modern Insects, are far in advance of their "forbears" as regards development, and this is especially true of all the higher forms of life.

Just as in the Vegetable world our modern Flora (with its wealth of Flowering plants) is far more highly organised, varied and beautiful than in the past ages of the world, so is the associated Fauna of to-day when contrasted with that of the past.

But, it may be asked, what prospect is there of arriving at the earliest known ancestor from which all these varied forms have been derived? What help does the geological record afford us? My duty, as your guide, is to inform you that our increased knowledge of the older rocks has not shown that we are nearer the fulfilment of the young biologist's dream, and the secret of Pandora's Box remains still undiscovered. We have not as yet reached the beginning of life.

FIG. 36.—TABLE SHOWING THE APPEARANCE AND RANGE IN TIME OF THE PRINCIPAL DIVISIONS OF THE INVERTEBRATA.

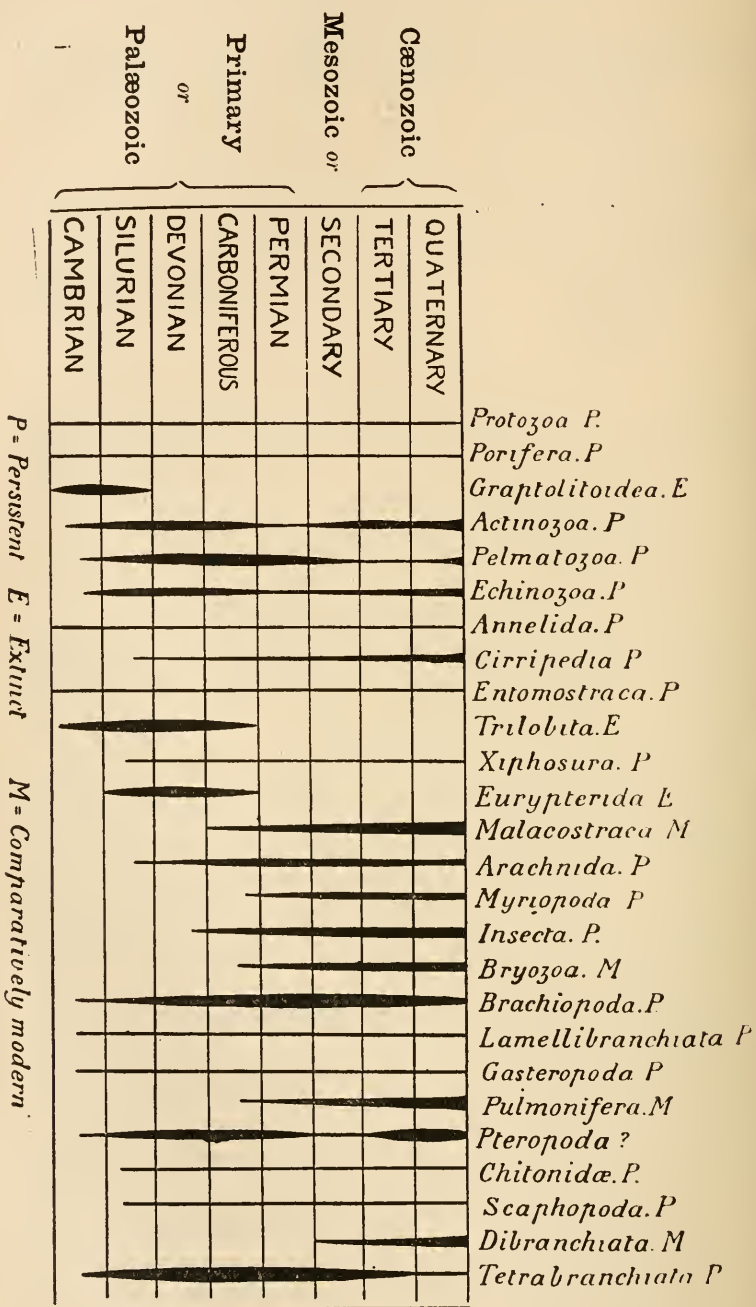

In the oldest Cambrian of North America, Prof. C. D. Walcott has shown the presence of some 61 so-called genera and 142 reputed species, embracing Sponges, Corals, Annelids, Graptolites, Echinoderma, Brachiopoda, Mollusca, lowly Crustacea, and Trilobites. But, *after all our labours, and strivings* to reach the beginning of all things, let us take comfort in this, that, like Pandora of old, we still have HOPE left us in the Box (or shall we say *in the Rocks?*).

Those Eozoic Rocks (see p. 146) which underlie our present oldest fossiliferous strata, may yet yield to the geologist and biologist in the future, an earlier and more primitive fauna and flora, just as the Lower Cambrian rocks have done for us in the past.

NOTE.—Prof. C. D. Walcott, in his monograph on the LOWER CAMBRIAN or “Olenellus Zone” of North America, gives the following list of fossils:—

	<i>Spongiæ</i> .. .. .	4 gen. et 4 sp.	
	<i>Actinozoa</i> .. .. .	5 “ 9 “	
	<i>Worm-tracks?</i> .. .. .	4 “ 6 “	
	<i>Graptolitidæ</i> .. .. .	2 “ 2 “	
	<i>Echinoderma</i> .. .. .	1 “ 1 “	
	<i>Brachiopoda</i> .. .. .	10 “ 29 “	
Mollusca	{ <i>Lamellibranchiata</i> .. .. .	3 “ 3 “	
	{ <i>Gasteropoda</i> .. .. .	6 “ 13 “	
	{ <i>Pteropoda?</i> (doubtful)	4 “ 15 “	
			39 gen. et 82 sp.
	<i>Crustacea</i> —		
	<i>Isorys</i> .. .. .	1 gen. et 1 sp.	
	<i>Ostracoda</i> .. .. .	3 “ 6 “	
	<i>Protocaris</i> .. .. .	1 “ 1 “	
			5 gen. et 8 sp.
	<i>Trilobita</i> —		
	<i>Agnostus</i> .. .. .	1 gen. et 3 sp.	
	<i>Microdiscus</i> .. .. .	1 “ 8 “	
	<i>Olenellus</i> .. .. .	1 “ 4 “	
	<i>Mesonacis</i> .. .. .	1 “ 2 “	
	<i>Holmia</i> .. .. .	1 “ 1 “	
	<i>Olenoides</i> .. .. .	1 “ 5 “	
	<i>Zacanthoides</i> .. .. .	1 “ 2 “	
	<i>Bathynotus</i> .. .. .	1 “ 1 “	
	<i>Avalonia</i> .. .. .	1 “ 1 “	
	<i>Conocoryphe</i> .. .. .	1 “ 2 “	
	<i>Ptychoparia</i> .. .. .	1 “ 8 “	
	<i>Crepicephalus</i> .. .. .	1 “ 2 “	
	<i>Oryctocephalus</i> .. .. .	1 “ 1 “	
	<i>Anomocare</i> .. .. .	1 “ 1 “	
	<i>Agraulos</i> .. .. .	1 “ 3 “	
	<i>Protypus</i> .. .. .	1 “ 3 “	
	<i>Solenopleura</i> .. .. .	1 “ 5 “	
			17 gen. et 52 sp.
	Nine groups are represented, comprising .. ..		61 gen. et 142 sp.

## OBITUARY.

JAMES GLAISHER, F.R.S. F.R.A.S. F.R. Met. S. F.R.M.S.

1809-1903.

JAMES GLAISHER was born on April 9, 1809. When only 20 years of age he was engaged on the Ordnance Survey of Ireland. In 1833 he obtained an appointment as assistant at the Cambridge Observatory, but two years later followed Prof. Airy to Greenwich. In 1841 he was placed at the head of the newly founded Magnetic and Meteorological Department, a post which he retained till 1874, and during his term of office inaugurated the quarterly reports issued by the Registrar-General. Mr. Glaisher was an enthusiastic aeronaut, not so much for the love of the ascents as in the hope that important discoveries relating to the constitution of the atmosphere might be made from these excursions. In one of these ascents, made in company with Mr. Coxwell, on September 5, 1862, a height of nearly 7 miles was attained. On this occasion Mr. Glaisher became unconscious and Mr. Coxwell had to use his teeth, his hands being quite benumbed, to pull the valve-rope in order to effect a descent.

Mr. Glaisher was President of the Royal Microscopical Society from 1865-1868. He was also a member of the Royal, the Royal Photographic, the Royal Aeronautical, and the Royal Meteorological Societies. Of this last, he was the founder, its Secretary for twenty years, and its President in 1867-8.

Besides many articles in the *Philosophical Transactions* and other scientific journals, he was the author of *Hygrometric Tables*, *Travels in the Air*, and the translator of Guillemin's *Les Comètes*.

Mr. Glaisher died on February 7, 1903, and was buried at Shirley, near Croydon.

---

REV. THOMAS WILTSHIRE, M.A. D.Sc. F.L.S. F.G.S. F.R.A.S.  
F.R.M.S.

1826-1902.

THOMAS WILTSHIRE was born in the City of London on April 21, 1826. At the age of 19 he entered Trinity College, Cambridge, and while at the University developed a taste for geology, which continued to be the dominating pursuit of his after life. He took his B.A. degree in 1850, and in June of the same year was ordained. In 1859 he was elected President of the Geologists' Association, and in 1863 became Secretary of the Palæontographical Society, which office he held until 1899. From 1874 to 1878 he was one of the Honorary Secretaries of the Geological Society; in 1890 he was appointed Professor of Geology and Mineralogy at King's College; in 1888 he became Master of the Clothworkers' Company; and in 1899 received the honorary degree of Doctor in Science from the University of Cambridge.

Besides being much occupied in scientific pursuits and geological investigations, the Rev. Dr. Wiltshire was devoted to clerical work and lecturing, and it was shortly after delivering a Sunday evening discourse at St. Clement's, Eastcheap, that he passed quietly away after a busy life of 76 years.

His best known communications are papers 'On the Red Chalk of England,' and 'On the Ancient Flint Implements of Yorkshire and the modern fabrication of similar specimens.'

# SUMMARY OF CURRENT RESEARCHES

RELATING TO

## ZOOLOGY AND BOTANY

(PRINCIPALLY INVERTEBRATA AND CRYPTOGAMIA),

### MICROSCOPY, ETC.\*

#### ZOOLOGY.

##### VERTEBRATA.

###### a. Embryology.†

**Treatise on Comparative and Experimental Embryology of Vertebrates.**‡—O. Hertwig is making progress with the great co-operative treatise which he is editing. The last-published parts (Lieferungen 6–8) deal with the mouth, the buccal cavity (apart from teeth), the swim-bladder, the lungs, and the larynx (E. Göppert); with the intestinal system (F. Maurer); with the skin (W. Krause); and with the integumentary ossifications and the teeth (R. Burckhardt).

**Fertilisation in Salmon.**§—N. Czermak finds that there is a female centrosome in the salmon, and that in the approximation of the two pronuclei the female sphere is apposed to only one pole of the male pronucleus-spindle, so that only this pole—therefore only one of the first two blastomeres—exhibits a perfect fertilisation. The author gives a summary of the whole fertilisation-process as he observed it.

**Vestigial Function.**||—W. Wedekind points out that just as the comparative anatomist speaks of a rudimentary or vestigial organ, so the physiologist may speak of a rudimentary or vestigial function. Such a vestigial function is manifested by those ova of sea-urchins and some other animals, which under physical and chemical stimulus may be induced to develop parthenogenetically. The physico-chemical stimuli are not replacing the spermatozoic stimulus, they are simply liberating a vestigial function—to go on dividing.

**Organic Sexual Dimorphism in Fowls.**¶—F. Houssay notes that while cocks are larger, more muscular, with bigger comb, &c., the hens

\* The Society are not intended to be denoted by the editorial "we," and they do not hold themselves responsible for the views of the authors of the papers noted, nor for any claim to novelty or otherwise made by them. The object of this part of the Journal is to present a summary of the papers *as actually published*, and to describe and illustrate Instruments, Apparatus, &c., which are either new or have not been previously described in this country.

† This section includes not only papers relating to Embryology properly so called, but also those dealing with Evolution, Development, Reproduction, and allied subjects.

‡ 'Handbuch d. vergl. und exper. Entwicklungslehre d. Wirbeltiere,' Lief. 6–8, Jena, 8vo, 462 pp. and 263 figs.

§ Anat. Anzeig., xxii. (1903) pp. 393–400 (5 figs.).

|| Zool. Anzeig., xxvi. (1903) pp. 203–4.

¶ Comptes Rendus, cxxxvi. (1903) pp. 112–4.

have larger internal organs except in the case of heart and lungs, which are usually more strongly developed in cocks. He applies the phrase organic sexual dimorphism to the relation of female mean weight of internal organs to the male mean weight of the same. The ratios vary with the different organs (kidney, spleen, liver, pancreas, gizzard, cæca, &c.), and the dimorphism is not in any simple way connected with egg-laying or increase in gross weight. Houssay shows the curious changes brought about by carnivorous diet, but as yet the results are too complex to yield a satisfactory conclusion.

**Regeneration in Newts.\***—August Weismann reports the results of experiments made under his direction by Egon Breinig. In four cases the oviduct was removed, and no regeneration followed. Experiments with the vas deferens gave the same negative result. In the case of lungs, from which the end was cut off, there was a slight terminal expansion of the organ, but this may be regarded as the mechanical result of continued function. Weismann contrasts these results with the well-known regeneration of the eye—an organ which in natural conditions is liable to be injured by water-beetles, dragon-fly larvæ, and other enemies of the newts.

**Torsion of Bird-Embryo.†**—A. Weber has investigated the early stages of torsion on the longitudinal axis as observed in normal embryos of birds, but he has got much help by a study of two cases where the amnion was wholly absent,—a very rare anomaly.

**Gastrulation of Double-Development in Trout.‡**—F. Schmitt has made a careful study of this process. It occurs in blastoderms which are not larger than the normal nor richer in germinal material. The occurrence of double-embryos cannot be interpreted on the concrescence-theory without auxiliary hypotheses. A short summary is given by the author, but we must be content at present with a mere reference.

**Curvature of the Spine in Fishes.§**—J. Pellegrin brings together a number of cases of abnormal curvature and similar abnormalities in the vertebral column of Teleosts. He alludes to the sole (Howes), the perch (Howes), *Cobitis fossilis* (Giard), the mackerel (Petit), *Mullus surmuletus*, *Mugil capito*, *Trigla lyra* (Moreau), and so on. To what are these malformations due? According to Pellegrin, they are referable to muscular variations which influence the skeletal development.

#### b. Histology.

**Cell-Division.||**—A. Bethe contrasts the mechanical filament-theories (*Faden-theorien*) with the dynamical centrosome-theories to the advantage of the latter. He brings forward a number of facts described by various investigators which cannot be interpreted on the mechanical theory. The field is really left to the dynamical theories, that is to those interpretations which do not credit the achromatin threads with

\* Anat. Anzeig., xxii. (1903) pp. 425-31 (3 figs.).

† Journ. Anat. Physiol., x. xix. (1903) pp. 75-92 (1 pl. and 16 figs.).

‡ Verh. Deutsch. Zool. Ges., xii. Vers. (1902) pp. 64-83 (7 figs.).

§ Bull. Soc. Zool. France, xxvii. (1902) pp. 215-9 (3 figs.).

|| Internat. Monatschr. Anat. Physiol., xix. (1902) pp. 118-28.

an active (muscle-like) function, but refer the process of division to the chemico-physical properties of cytoplasm and nucleoplasm. It seems to him hardly possible to get beyond this vague generalisation until the chemical physiology of the cell is more advanced.

**Spindle-Residues in Cell-Division.\***—P. Bouin distinguishes the spindle-residue formed between two daughter-cells at the expense of the central-spindle-fibres and amalgamating into the intermediate corpuscle, from other spindle-residues built up after the telophase and after the disappearance of the vestiges of the karyokinetic spindle.

In the divisions of the spermatocytes of the first order in *Lithobius forficatus* there are three successive spindle-formations: (1) a primary protoplasmic spindle, extending during the prophase between the central corpuscles, but disappearing before the end of the prophase; (2) a secondary spindle, the true karyokinetic spindle, formed at the expense of the linin-framework of the nucleus; and (3) a tertiary spindle or spindle of separation, formed after the disappearance of (2), from fibrils differentiated *de novo* along the whole equatorial region, and giving rise, as the cell-membrane grows in, to a spindle-residue. This formation is not referable to the karyokinetic spindle; it is a new differentiation characteristic of the telophase.

**Trophospongia.** —E. Holmgren describes canal-like "*trophospongia*" in the cells of the epididymis of the white mouse and in the cells of the bile-duct epithelium of the snail. They occur exclusively within the granular or vacuolar triangular space to the external side of the nucleus, and do not show any direct connection with the fibrillar or threadwork apparatus of the cell. The same disposition was found in the epithelial cells of the mammalian uterus and thyroid gland.

**"Intracellular Threads" in Ganglion-Cells of Electric Organ of Torpedo.†**—B. Solger returns to a study of these structures to which he gives an interpretation somewhat different from that in his paper of 1897.§ He thinks there is a coherent system of canaliculi and spaces penetrating the cell-substance, here and there opening externally into the pericellular space, and often including thread-like structures which stain deeply with iron-hæmatoxylin, and sometimes fill up the lumen. His point is, that the granular threads are in connection with the intracellular canaliculi and spaces, are, in fact, concretions or precipitates within some of them.

**Intranuclear Space in Liver-Cells.||**—Gustav Schlater finds that the nucleus of the hepatic cell is very elaborate. It includes a space ellipsoidal like itself, and with the same centre. Between the surface of this space and the surface of the nucleus is the body proper of the nucleus. This includes six nucleolar apparatuses (*Kernkörperchenapparate*), quite definitely disposed, so that the lines joining them form a regular octahedron. More superficially is the so-called chromatin net-

\* Arch. Zool. Expér., x. (1902) Notes et Revue, No. 7, pp. cvi.-cix.

† Anat. Anzeig., xxii. (1902) pp. 83-6 (2 figs.).

‡ Morph. Jahrb., xxxi. (1902) pp. 104-15 (1 pl.).

§ SB. Med. Ver. Greifswald, May 1897; Tagbl. Naturforsch. Vers. Braunschweig, Sept. 1897.

|| Anat. Anzeig., xxii. (1902) pp. 249-59 (1 fig.).



work bearing chromatin-granula or cytoblasts (chiefly basichromatin). Finer than this is the "linin-framework" which traverses the whole body of the nucleus and unites the nucleolar apparatus and the microsomes (chiefly oxychromatin). In the meshes of the chromatin and linin-framework there are the cyanophil granules (Altmann's granula).

**Structure and Development of Cartilage.\***—O. V. Srdinko has studied this in man and mammals, in adult and embryonic stages. In the embryonic condition the hyaline cartilage has cells with numerous long ramifying protoplasmic processes. These cells have no capsule, and divide so that rows of daughter-cells arise. Many are in very young stages united by plasmic anastomoses. The fundamental substance is homogeneous or fibrillated; the fibrillation follows in consequence of the impenetration of nutritive juices. This embryonic cartilage leads directly to hyaline cartilage, the cells losing the strong processes and becoming surrounded by a capsule. Part of the fundamental substance undoubtedly arises by direct modification of the cells.

In mature hyaline cartilage, there is no persistence of the embryonic processes. Bundles of fine fibres are seen in the fundamental substance running from cell to cell. The nutrition of the cartilage is probably effected by impenetration of fluids along the fine bundles of fibres, which in this way come to stand out clearly amid the matrical substance.

**Development and Structure of Vitreous Humour.†**—P. Bertacchini has studied this in various mammals. He comes to the following conclusions among others. The vitreous humour is not a connective tissue in which the cells have disappeared by atrophy, nor a simple vascular transudation, nor a secretion of retinal cells; and it has no developmental connection with the small quantity of mesoblast which remains included in the optic cup or enters by the choroid fissure. It is a tissue of secondary origin, exclusively due to the blood-vessels through the mediation of leucocytes. The original vitreous cells are leucocytes which have passed from the blood by diapédesis. The humour never loses its cells, though these are superficially disposed.

The intercellular substance of the vitreous humour is secreted by the vitreous cells in all the stages of development. In early foetal life, the cells secrete an unstainable gelatinous substance, which appears as gelatinous spheres in the cytoplasm, and passes out by dehiscence. Subsequently the mode of secretion changes a little; it is associated with the formation of stainable granules and the detachment by clasmatosis of plasmic prolongations. After birth this is the only method. It is probable that the gelatinous drops give rise to the aqueous part of the corpus vitreum, and that the detached plasmic fragments with their stainable granulations form the denser part, and the mucin in particular.

**Structure of Digestive Canal in Reptiles.‡**—F. Béguin gives an account of the minute structure of the digestive canal in common

\* *Anat. Anzeig.*, xxii. (1903) pp. 437-46.

† *Internat. Monatschr. Anat. Physiol.*, xix. (1902) pp. 77-118 (2 pls.).

‡ *Rev. Suisse Zool.*, x. (1902) pp. 251-397 (6 pls.).

Chelonians, Lacertilians, and Ophidians. He gives a useful summary of fifteen chief conclusions, but our space will not admit of more than a reference to a few. The development of the alimentary muscular layers is at its minimum in snakes, which may be associated with the strong muscularity of the body-wall. In most cases there is no basal membrane beneath the epithelium; there are no cell-walls, but there is often intercellular substance, and there may be intercellular bridges. The œsophageal mucosa shows interesting stages of differentiation from ciliary to stratified epithelium. Œsophageal glands occur in some Chelonians. The gastric glands are very deep in Chelonians, deep in lacertiform lizards, much less deep in serpentiform lizards and in snakes. In the mid-intestine there is a lining of cylindrical cells with plasmic prolongations differentiated into rods and with a small quantity of intercalary substance. These rods exhibit pseudopodial movements, and ingest like Amœbæ. Cylindrical and calyciform cells in the intestine are usually the same elements at two stages. Béguin pays particular attention to the glandular cells of the stomach.

**Structure of Intestinal Villi.\***—F. Vosseler has studied the villi of the small intestine in many animals, and he calls attention to numerous peculiarities of structure. Thus he has found that, quite apart from results of injury or degeneration, the villus may show an opening at or somewhat lateral to its apex. Sometimes two are present. They are elongated clefts, bordered by cylindrical epithelium, and with the margins all but touching. Not infrequently the stroma of the apical region of the villus is cleanly retracted from the enveloping epithelium, so that between the two tissues there is a cap-shaped or cylindrical cavity containing some granular debris and leucocytes, but without any formed fibrous components. Vosseler considers the possible physiological import of the structural facts described.

**So-called "Telescopic" Eye of Some Abyssal Fishes.†**—A. Brauer describes a kind of eye that frequently occurs in deep-sea fishes and in some pelagic forms as well. He refers to some interesting cases in which incipient stages towards the so-called telescopic eye occur.

The chief characteristics of the peculiar type of eye alluded to may be summed up as follows. The form is more or less like a tube, its opening—the pupil—is always very wide, the iris is almost degenerate. The pupil is usually quite filled by a large lens, which is over-arched by a very convex cornea. Even more peculiar is the fact that the retina is divisible into two parts which are dissimilar in their differentiation. The large part—the main retina—lines the whole back of the eye, is usually homogeneous, and is always highly developed. It is marked by the great length and large number of the rods, many of which are unusually far from the lens because of the elongation of the region between the cornea and the back of the eye. The smaller part of the retina (*Nebenretina*) usually occurs on the median wall of the eye, and is in various degrees reduced when compared with the main-retina. The layers are thinner; the percipient elements, when present, are less numerous, shorter, and

\* Verh. Deutsch. Zool. Ges., xii. Vers. (1902) pp. 203-13 (4 figs.).

† Tom. cit., pp. 42-57 (7 figs.).

thicker. Their best development is dorsally, close to the lens. Only in *Gigantura* is there on the ventral wall, about the middle, a small representation of the accessory retina. The eyes are directed not laterally but dorsally, or rostrally; and the interorbital space is reduced to such a thin septum that the eyes almost touch, like the eyes of one looking through a field-glass. While many of the eye-muscles are divergent or reduced, when compared with the norm, the accommodation-apparatus is well developed. The author gives many detailed illustrations and a general interpretation of these peculiar eyes as adaptive to special conditions.

### c. General.

**Biological Observations on Reptiles and Amphibians.\***—F. Werner gives in the first place an account of his experiments as to the "tropisms" of reptiles and amphibians. (a) Most reptiles are more or less markedly heliotropic, and many seek the light apart from warmth. In amphibians, heliotropism is much less marked. (b) The persistent upward climbing of species of *Hyla*, *Dryophis*, *Anolis*, and *Chamaeleon* is interpreted as negative geotropism. (c and d) Positive geotropism is always associated with stereotropism, as seen in *Amphisbænida*, *Typhlopida*, *Scincoida*, and limbless amphibians. (e) Hydrotropism, as a particular kind of chemotropism, is strikingly illustrated by *Triton*, *Bombinator*, *Ungalia semicineta*, *Gerrhonotus caruleus*, &c., which persistently make for water, even from considerable distances.

Secondly, Werner discusses the sensory perceptions of reptiles and amphibians (186 different forms). (1) Vision is particularly acute as regards food and enemies. Crocodiles, which see best sideways, do not seem to perceive a fish at a distance greater than half their own length, but they see a man at ten times their own length or even more. Tortoises far excel crocodiles in acuteness of vision as regards food, but they seem less sensitive to the approach of man. Some lizards can see food at a distance of 1-3 yards; others are very short-sighted. Snakes are mostly dull of sight. The Urodela are far inferior to the Anura in range of vision. A large number of precise measurements in terms of body-length are given. (2) As regards hearing, all reptiles are deaf or at any rate dull; the crocodiles react to a few noises, and the geckos come next. The Urodela have little power of hearing, but frogs have considerable sensitiveness. (3) All the forms tried reacted to strong odours, such as those of alcohol and formol. (4-6) Interesting facts are given in regard to the gustatory, tactile, and pressure-senses.

In his third chapter Werner discusses maximum and minimum size. He notes that the attainment of maximum length does not coincide with sexual maturity. Half-grown *chamaeleons*, snakes, &c., may be sexually mature. In many cases there is no definite limit of growth; many grow as long as they live and never show any senile weakness, their death being violent not "natural." Even in abnormally large individuals there is no trace of senile degeneration. An interesting set of figures show for *Boa*, &c., a ratio between the adult size and that of the newly-born young. Length of life is also discussed, and it is noteworthy that within

\* Biol. Centralbl., xxii. (1902) pp. 737-58.

one genus, e.g. *Lacerta*, there are species which live for a year or for two years and others which survive several decennia.

The different sizes attained by different varieties or species seem to be related in the first instance to the diet,—that of carnivorous forms depending on the size of the available victims. Those which eat small creatures become sexually mature and reach their limit of growth sooner than those which eat larger animals. There is a wealth of very interesting information in this paper which we have only hinted at.

**Phylogenetic Speculations.\***—H. Simroth discusses the origin of vertebrates, sponges, and sexual reproduction, but his paper is very elliptical, leaping over obvious difficulties and what seem to us necessary steps in the argument. As might have been expected from the author of *The Origin of Land Animals*, he re-emphasises the evolutionary advantages of terra firma. It was on land that vertebrates were vertebrated, the "*Urstamm*" being the "Tetrapoda," the place of origin being probably the "East Pole." Even the head, he seeks to interpret as "a product of terrestrial life." He refers the sponges to an origin from terrestrial Acœla (Turbellarians), he derives the Acœla from Infusorians, and the Infusorians from "Probacteria" arising in the organic matter which preceded life. Sexual reproduction is also a product of the "*Landleben*," which appears to have given initiative to all the more important steps in evolution. We regret our inability to follow Prof. Simroth's argument.

**Text-book of Zoology.†**—A. Goette has written a text-book of Zoology for serious university students,—a terse and accurate description of animal forms from the comparative anatomist's point of view. According to the preface, it is intended to be distinctively evolutionist, showing the progress of organisms from one grade of structure to another. But we do not find any particular evidence of this in the text, and many of the classifications are extremely conservative and dogmatic. There is too little embryology, too little palæontology, and too little œcology to justify the title '*Lehrbuch der Zoologie*.' But it is the work of an expert, who has done much for Zoology in the widest sense, and its workmanship is good, though, as it seems to us, one-sided.

**Anomalies on Head-Shields of Snakes.‡**—L. H. Gough makes a contribution to the study of variation by giving a list of the anomalies in the head-shields of the snakes in the collections of the University of Strassburg. The anomalies consist chiefly in a difference in the numbers or arrangement of the shields (especially the temporals) on the two sides of the head.

**Abnormal Coloration in Pleuronectids.§**—W. C. McIntosh describes a number of adolescent turbot showing a deep notch above the head, the dorsal fin terminating in a prominent hook, and coloration on *both* sides. He describes other cases of coloration on the under side on sole, flounder, dab, and plaice. Such cases raise doubts as to whether illumination is responsible for the development or non-development of

\* Verh. Deutsch. Zool. Ges., xii. Vers. (1902) pp. 152-62.

† '*Lehrbuch der Zoologie*,' Leipzig (Engelmann), 8vo, xii. and 504 pp. and 512 figs.

‡ Zool. Jahrb., xvii. (1902) pp. 457-68.

§ Ann. Nat. Hist., ix. (1902) pp. 291-308.

pigment in Pleuronectids. Moreover, in metamorphosing young examples the side which is to be pale becomes considerably less pigmented before the fishes swim obliquely or leave their pelagic life. Apart from the influences of light, other factors are operative,—various constitutional peculiarities and the influence of the sympathetic system of nerves.

**Geographical Distribution.**\*—J. Palacký seeks to show in a learned essay that the territorial mapping of zoo-geographical regions—which will apply to the various phyla—is a hopeless task. Whether the regions be those of Wallace and Sclater, or those suggested by others, they do not fit the facts. The useful task is to take class by class and to correlate their present distribution with what geology has to tell us.

**Phylogeny of Erinaceidæ.**†—W. Leche continues his splendid work on the evolution of mammalian dentition, with special reference to the Erinaceidæ. His results are based on a study of 263 skulls and jaws, and on an associated investigation of the other parts of the skeleton and of the soft parts. The outcome is a very important contribution to odontology in general and to the history of the Erinaceidæ in particular. There is an excellent review of the work by M. Fürbringer.‡

**Throwing-Net and Mud-Sucker.**§—O. Zacharias describes what experience has proved to be a really effective throwing-net for use in plankton work on water-basins that have to be worked from the shore, and also an improved mud-sucker for capturing Rhizopods, Infusorians, and the like.

**Fauna of Alpine Lakes.**||—P. Buffa gives a physical and biological account of some alpine lakes of the Trentine mountains. His lists include 12 Protozoa, 23 Rotifers, 7 Crustaceans, and 3 larval Diptera.

#### Tunicata.

**Development of Appendicularia.**¶—R. Goldschmidt notes that there are only two records of observations on this subject, namely, by Kowalevsky and Fol, both to the effect that the development of *Appendicularia* does not differ essentially from that of Ascidians. Goldschmidt studied what were probably the young stages of *Oikopleura dioica* Fol. The minuteness, the extremely refractive character of the living embryo, and the marked poverty of chromatin in the embryonic nuclei made the investigation very difficult. But he confirms circumstantially what Kowalevsky and Fol said, that the development is in no essential features different from that of Ascidians.

### INVERTEBRATA.

#### Mollusca.

##### a. Cephalopoda.

**Nature and Development of Chromatophores.**\*\*—Carl Chun has studied the chromatophores in a species of *Bolitaena* (*Eledonella*), and

\* Verh. Deutsch. Zool. Ges., xii. Vers. (1902) pp. 137-52.

† Zoologica, Heft 37 (1902) 104 pp. (4 pls. and 59 figs.).

‡ Morph. Jahrb., xxxi. (1902) pp. 116-21.

§ Zool. Anzeig., xxvi. (1903) pp. 201-3.

|| Atti Soc. Veneto-Trentina Sci. Nat., iv. (1902) pp. 5-32.

¶ Biol. Centralbl., xxiii. (1903) pp. 72-6 (3 figs.).

\*\* Verh. Deutsch. Zool. Ges., xii. Vers. (1902) pp. 162-82 (11 figs.).

his account of them differs in some noteworthy respects from that given by previous investigators. He has traced their development from a cell with a single nucleus, through stages with two, four, eight, sixteen, and thirty-two nuclei. The chromatophore is not formed by a secondary combination of originally separate elements, it is a single, complex, multinucleate cell. One large and peculiar nucleus remains in the centre; the others are disposed peripherally at the bases of the radiating contractile processes. The resemblance to a multinucleate Protozoon is striking.

The radiating contractile fibres are not secondarily connected with the central pigmented portion, but arise from it primarily, just like pseudopodia. Kölliker's old conclusion that the radial fibres are contractile and act in the expansion of the chromatophore is quite correct, but the fibres are parts of the chromatophore. The contraction of the chromatophore is due to contractile arcs at the margin of the cell, stretching like bows between the basal portions of adjacent radial fibres. Some of Chun's figures are very striking.

**New Cuttle-fishes.\***—L. Jourdain makes a brief communication in regard to the Cephalopods collected in 1901-2 by the Prince of Monaco, chiefly in the vicinity of the Azores. There is a large species of *Cirro-teuthis* (*C. grimaldii* sp. n.), notable for its massive ovoid form and gelatinous consistence. The arms are enveloped in a thick membrane which almost masks them, only the tips being free; there is no separation between arms and head, or between head and body, the whole being enclosed in a cutaneous envelope. Very different is the small *C. richardi* sp. n. The author makes short notes on *Eledonella diaphana* Hoyle, the third specimen known, remarkable for its soft and transparent tissues; on *Leachia cyclura* Lesueur which has luminous organs; and on a new species of *Rossia* (*R. caroli*) with enormous eyes which make the head bigger than the rest of the body.

**Chorion and Micropyle in Cephalopods.†**—A. Schweikart has followed up Bergmann's research on oogenesis in Cephalopods, and has utilised some of his slides. The chorion begins to be formed by the separation of drops or granules from the follicular epithelium; these coalesce into a continuous homogeneous membrane. The stages in the formation are described with particular reference to *Sepiola*, where the truly chorionic nature of the envelope is very clear. The formation of the micropyle as a canal traversing the chorion at its thin region over the animal pole is described with special reference to *Rossia macrosoma*.

#### γ. Gastropoda.

**Retina of Gastropod Eye.‡**—R. Hesse notes that previous investigators are at one in describing two kinds of cells in the retina of the Gastropod eye—pigmented and unpigmented—but that there is no unanimity as to which kind of cell is sensory. Some say the pigmented cells are optic, others say the unpigmented, others say both. The

\* Comptes Rendus, cxxxvi. (1903) pp. 100-2.

† Zool. Anzeig., xxvi. (1903) pp. 214-21 (2 figs.).

‡ Verh. Deutsch. Zool. Ges., xii. Vers. (1902) pp. 121-5 (2 figs.).

problem is to discover which cells are in connection with the fibres of the optic nerve, or which exhibit a "rod" structure. Hesse finds rod-like structures in all the Gastropod eyes which he has studied, and he gives a brief account of their structure, which exhibits considerable diversity, in *Helix*, *Limax*, *Patella*, *Turbo*, *Murex*, and other forms. In *Helix* and *Patella* he demonstrated the expected connection between the rod-bearing cells and nerve-fibres. Between these truly optic cells there are always indifferent cells without rods.

As regards the distribution of pigment in the retinal cells, "all possible combinations are realised." Rod-cells and indifferent cells may be pigmented, as in *Pleurobranchus* and *Murex*; the rod-cells may be pigmented and the indifferent cells not, as in *Patella*; the converse is true of *Helix* and *Turbo*; or both rod-cells and indifferent cells may be free from pigment, as in *Limax*. The absence of pigment in *Limax* shows that the pigment has no essential rôle in vision; it simply serves to isolate the optic elements, and may be dispensed with altogether. In *Limax* there is an accessory retina, or *Nebenretina*, comparable to that which Brauer has described in deep-sea fishes.

**Structure of *Lucapina crenulata*.\***—J. F. Illingworth gives an account of this mollusc, and notes the following results as most important. The epipodium is rudimentary and the nerve going to it is very weak. The pharynx is enlarged into a crop-like pouch with many folded digestive glands. Three large distinct hepatic ducts enter the stomach.

The nephridia are very unsymmetrical. Both have external openings, and the right has an indirect reno-pericardial duct. The oviduct opens just within the external papilla of the right kidney, and the reno-pericardial duct is a short tube leading from the right side of the pericardial cavity, and opening into the oviduct. The epithelial cells lining the duct are very large, with exceedingly long cilia.

The shell muscles are distributed along the margin of the shell and very weak.

The vascular system is closed; there are two auricles with a ventricle between them; joining the ventricle is a large, rectangular aortic chamber, from which three aortæ arise—an anterior or buccal, a gastric, and a posterior or genital aorta. The mantle circulation is well developed; the blood is distributed by a pallial artery that surrounds the body and returns in the pallial sinus, which lies parallel and close to the artery. The blood does not pass through the gills before returning to the heart. The pedal collectors form a close meshwork of veins over the inner surface of the foot. The ctenidia are symmetrical.

The cerebral ganglia are joined to the pleuro-pedal ganglia by two pairs of connectives. The pleural and pedal ganglia are in the form of short cords closely fused along their whole length. A ganglionic nerve lies just within each osphradium. The circum-pallial cord, a chain of small ganglia, encircling the visceral cavity, is joined to the pleural cords by a great number of connectives, each of which sends a small nerve to the epipodium.

\* *Zool. Jahrb.*, xvi. (1902) pp. 449-80 (3 pls. and 15 figs.).

**Purple of Dog-Whelk.\***—R. Dubois has previously shown that the purple of *Murex brandaris* is the result of the transformation of a substance which he called *purpurine* by a ferment which he called *purpurase*. These substances occur in the purple gland, and, by their interaction, give rise to unstable bodies whose change in various physical conditions results in the purple fluid. As Letellier has stated that this does not hold true of *Purpura lapillus*, Dubois has repeated for this animal the observations which he made on *Murex*, and finds that the same is true in both cases.

**Relations of Kidneys and Gonads in Haliotis.†**—R. J. Totzauer finds that the two kidneys are quite separate, opening apart into the branchial cavity; that the rudimentary left kidney opens on a papilla, without a proper efferent canal such as the right kidney has; that the left kidney is connected with the pericardium by a reno-pericardial duct; that the relations between pericardium, right kidney, and gonads correspond precisely to what Pelseuer has described for Fissurellidæ and Trochidæ, except that in front of the communication between genital duct and reno-pericardial duct, there is a second communication between genital duct and right kidney, similar to that described in *Parmophorus intermedius* by Tobler.

#### δ. Lamellibranchiata.

**Formation of Pearls.‡**—H. Lyster Jameson has studied this in *Mytilus edulis* and some other bivalves. The formation of a true pearl is like that of the shell, except that a pearl is laid down in a closed sac of the shell-secreting epithelium, imbedded in the subepidermal tissue of the mantle and completely cut off from the outer epithelium itself. Inside this spherical epithelial sac, the shell substance is laid down in the characteristic concentric layers. Sac and pearl may be compared to a human atheroma cyst.

A sharp distinction must be drawn between true pearls and blisters or pearly excrescences of the shell lining, which are secreted by the outer mantle epithelium to cover over foreign intrusions, &c. "Concretions," again, are calcosphæritic bodies which have not a cuticular origin, but seem to arise by free crystallisation in the mantle or other tissues. The term "attached pearl" should be applied only to pearls which have become secondarily fused to the shell by absorption of the intervening tissues.

Pearls naturally vary according to the animal and according to the part of the mantle implicated. Thus, pearls formed at the margin are composed mainly of periostracum, e.g. leathery pearls of *Modiola modiolus*, while those which occur in the part of the mantle concerned in depositing the prismatic substance are made up of concentric layers of rod-like prisms, as in the brown pearls of *Margaritana margaritifera*. By far the greater part of the mantle epithelium deposits nacre, and typical pearls are of course nacreous. The material of the ligament is represented in the black leathery pearls sometimes found in the dorsal wall of the Australian *Margaritifera maxima* Jameson.

\* *Comptes Rendus*, cxxxvi. (1903) pp. 117-8.

† *Zool. Anzeig.*, xxv. (1902) pp. 487-8.

‡ *Proc. Zool. Soc. London*, 1902, pp. 140-66 (4 pls.).



The epithelial sac is first formed by a live Trematode, which may or may not persist there. The observations of Filippi, Möbius, and others are here confirmed. Sporozoa may also cause sacs.

The parasite of the mussel occurs in sporocyst stage in *Tapes decussatus* and *Cardium edule*; from these bivalves the cercariæ migrate to the mussel, as has been proved experimentally. It is almost certain that the adult stage of the parasite is *Distomum (Leucithodendrium) somaterie* Lev., found in the intestine of eider-duck and scoter.

The author suggests that artificial infection of pearl-oysters or pearl-mussels might turn out very profitable, and points out the futility of transferring young pearl-oysters to more convenient ground near shore unless it is certain that they are infected or will be infected. Perhaps the popular estimation of pearls will not be enhanced by these discoveries which proclaim them to be the cenotaphs of flukes.

**Muscular Apparatus of Anomia.\***—Jobert describes the structure of the adductor and ossicular muscle in *Anomia ephippium*, which opens and shuts its shell at almost regular intervals. The adductor includes striped and smooth muscle-fibres and a white band of fibrillar elastic tissue. The ossicular muscle of the adults is digastric, and the same three kinds of tissue are seen to be arranged in a very characteristic fashion. The brusque closure is due to the striped fibres; the elastic tissue and the smooth fibres effect slow closing and permanent closure. Jobert notes the close resemblance between the musculature of *Anomia* and that of *Pecten*.

**Synopsis of Carditacea.†**—W. H. Dall adds to his previous synopses one dealing with the Carditacea, a group intimately related to the Crassatellitidæ, Astartidæ, and Chamidæ. He directs attention, *inter alia*, to the absence of siphons, to the coarsely reticular gills, to the incubation within the atrium of the ovary or a specially developed fold of the ventral part of the mantle lobes which secretes and lines a shelly marsupium, to the sedentary life and usual occurrence of byssus in youth at least, to the mutable features of the hinge, and so on. The Carditacea are divided into the Carditidæ with the ligament and resilium external and united, and Condyllocardiidæ, with the resilium immersed and the hinge in a more or less permanently and imperfect state. Dall's synopsis includes seven new species.

## Arthropoda.

### a. Insecta.

**Sensitiveness of Ants to Ultra-Violet and Röntgen Rays.‡**—A. Forel and H. Dufour describe experiments which seem to remove all doubt from the conclusion that ants (*Formica fusca*) react to ultra-violet rays. The results of the experiments agree with those previously reached by Lubbock, Graber, and Forel. Under the influence of X-rays the ants remained motionless and were apparently quite unaffected.

\* Comptes Rendus, cxxxv. (1902) pp. 906-7.

† Proc. Acad. Nat. Sci. Philadelphia, 1902, pp. 696-716.

‡ Zool. Jahrb., xvii. (1902) pp. 335-8.

**Physiological Study of Metamorphosis.\***—J. Sosnowski has studied the quantity of carbon dioxide eliminated by the larvæ of *Musca vomitoria* and *Lucilia cæsar* in the later stages of their development. The quantity eliminated decreases as the larva approaches the pupa stage. Illumination increases notably the quantity of carbonic acid eliminated, especially towards the transformation into pupæ. The quantity of ammonia liberated diminishes regularly from the time the larvæ cease to eat until they become pupæ, and the quantity is increased by illumination. As for the liberation of carbonic acid from the pupæ, it decreases rapidly during the first day, remains almost constant for several days, and increases again to the old amount as the fly prepares to emerge from the cocoon.

**Pseudogyny in Formica, and its Cause.†**—E. Wasmann returns with fresh light to a discussion of "pseudogyny" in *Formica sanguinea*, &c. A pseudogynous form exhibits a somewhat deformed combination of the thorax-structure of a female with the abdominal development and body-size of a worker. It seems to be due to a post-embryonic inhibition of the typical female constitution, probably occurring in larvæ which were originally destined to be females, but were subsequently reared as workers. What Wasmann has now shown is, that the occurrence of pseudogyny is in causal connection with the rearing of larvæ of the myrmecophilous beetle *Lomechusa strumosa*. It is never seen except in species and in colonies of *Formica* which rear these beetle-larvæ or similar larvæ, e.g. of *Atemeles* or *Xenodusa*. The care of these guest-larvæ seems sometimes to bring about an aberration or mistake in the rearing of the ant-larvæ.

**Stingless Bees (Melipona) of Pará.‡**—A. Ducke gives an account of the representatives of the genus *Melipona* found in the state of Pará. No fewer than 42 species are described, and *Trigona* is recognised as a necessary sub-genus.

**New Termites, Termitophils, and Myrmecophils.§**—E. Wasmann reports on a collection chiefly made by Dr. W. Horn in Ceylon. He describes *Arrhinotermes heimi* g. et sp. n., *Microtermes globicola* g. et sp. n., *Speculitermes cyclops* g. et sp. n., and numerous new species. He gives an account of some new termitophilous Coleoptera, Diptera, Hymenoptera, and Pseudoneuroptera, and of three new myrmecophils. This is the author's 129th contribution to this general subject.

**Guests of the Dorylinæ.||**—E. Wasmann has continued his interesting investigations on the Coleopterous (Staphylinid) guests of the predeaceous driver-ants (Dorylinæ), such as *Eciton* in South America and *Anomma* in Africa. The guests may be divided into four groups according to the nature of their adaptation to their hosts. (1) There are guests of the "Mimicry-Type," e.g. *Mimeciton*, which in superficial sculpture, form, antennæ, and coloration resemble their hosts; they

\* Bull. Acad. Internat. Sci. Cracovie, 1902, No. 8, pp. 568-73 (3 curves).

† Verh. Deutsch. Zool. Ges., xii. Vers. (1902) pp. 98-108 (1 pl.).

‡ Zool. Jahrb., xvii. (1902) pp. 285-328 (1 pl.).

§ *Ibid.* cit., pp. 99-164 (2 pls.).

|| Verh. Deutsch. Zool. Ges., xii. Vers. (1902) pp. 86-98 (1 pl.).

never have compound eyes and are often blind. (2) There are guests of the "*Trutztypus*," in which the form of the body is not readily gripped, e.g. Cephaloplectini (Xenocephalini) and Pygostenini. Their frequent colour-resemblance to their hosts is probably adaptive to external enemies. (3) There are guests of the "*Symphilentypus*" which give off a secretion pleasant to their hosts who lick them. (4) There are guests of the "*indifferent type*," e.g. *Myrmedonia*, which retain more or less of the form of their non-dorylophilous relatives, and are connected by incipient and half-way transformations with one or other of the three preceding types.

In the second part of his communication Wasmann illustrates in a very interesting way the convergence between neotropical and ethiopian guests of each of the first three types above-mentioned. There is a very striking parallelism, e.g. between *Mimeciton* and *Dorylomimus*, between *Symploemon* and *Ecitogaster*.

The third part of the paper continues the comparison of American and African forms. Wasmann gives the "palm of mimicry" without hesitation to *Mimeciton pulex* whose reflection of *Eciton*-characters is extraordinary. Some of the African forms are more accurately mimetic as regards thorax-form, e.g. *Dorylosthetus*, but the ideal of mimicry is to be seen in *Mimeciton*. Sometimes the mimetic resemblance is "excessive and exaggerated," thus *Mimeciton* has actually lost faceted eyes. The author has many more notes of great value to the student of adaptations.

**Exuvial Glands in Insects.\***—W. L. Tower has carefully studied the structure of the exuvial glands and the formation of the exuvial fluid in the larvæ of the Chrysomelid beetle, *Leptinotarsa decemlineata* Say. He maintains that the exuvial glands are not true glands, but the setigerous cells which, in early life, are chiefly concerned with the formation of the hairs upon the body. Upon the loss of these, the cell takes on the function of secreting the exuvial fluid, which is most copious at pupation. These cells degenerate in the pupa, and take no part in the formation of the imaginal ornamentation.

**Hepatic Function in Insects.†**—A. Porta has demonstrated a biliary secretion in *Coccinella* and he states briefly his conclusion that this occurs (1) in the cæca, (2) in the villousities of the stomach wall, and (3) in glands which lie in the wall of the mesenteron between the muscle-strands.

**Excretion in Gnat Larvæ.‡**—S. Metalnikoff has continued Kowalevsky's work on the excretory function of the pericardial cells. Carmine introduced into the gut is absorbed by the large epithelial cells of the mid-gut and passed on into the general cavity of the body. In other words, it passes into the blood. The leucocytes have no part so far. The pericardial cells soon show a rosy colour. They lie on each side of the heart, two pairs on each segment except the first, which has only one. After they have taken in the carmine they begin to break up and

\* Zool. Anzeig., xxv. (1902) pp. 466-72 (8 figs.).

† Anat. Anzeig., xxii (1903) pp. 447-8.

‡ Bull. Acad. Imp. St. Pétersbourg, xvii. (1902) pp. 49-58 (2 p's.).

disappear, probably with the aid of the leucocytes which subsequently often show carmine corpuscles. The author describes the heart in detail.

**Food-Canal of Larvæ of Cuckoo-Spit.\***—G. Gadd has studied the structure of the gut in the larvæ of *Aphrophora spumaria*. Besides the Malpighian vessels (two pairs) which open into the intestine, there are two long cæcal appendages of the stomach. The first, which opens into the anterior part of the stomach, has in its posterior half large cells with spherules which give evidence of substances belonging to the guanin group. The second appendage, which opens into the posterior region of the stomach, has quite different cells with long processes. The two are united terminally by connective tissue. The first is excretory, the second glandular. Gadd points out that in Arachnoids and Amphipods the mid-gut appendages have an excretory function.

**Normal Asymmetry of the Wings in *Naucoris cimicoides*.†**—Günther Enderlein makes an interesting note on the fact that the anterior right wing of this aquatic insect is different from the left. The stigmata lie on the dorsal surface of the flat body and are covered by the wings which leave a space between them and the back. This space is an air-reservoir, and it requires to be tightly shut. In adaptation to this end the right wing is strengthened and modified for effective closure, and it is always on the top. In related forms, e.g. in the exotic *Macrocoris flavicollis* from Zanzibar, the right wing is always uppermost. This is a fine example of adaptation to a peculiar mode of life.

**Injurious Influence of Thrips on Man.‡**—S. Artault de Vevey describes an interesting case of a feverish tuberculous patient who suffered from extreme itching on the uncovered parts of his body. These were attributed by him and his nurses to small black insects which came in crowds through the open window. The author identified them as *Melanothrips obesa* Fr., which were attracted to the patient at his crises of high temperature, and left him in the intervals. It is suggested that the irritation was due to the minute insects introducing their probosces into the sudoriferous pores.

**Statistical Study of Scale Insects on Fruit.§**—L. Reh has made a detailed study of the occurrence of various species found on fruit brought to Hamburg,—species of *Aspidiotus*, *Mytilaspis*, and *Chionaspis*. He gives statistics as to the occurrence of males, as to age, as to the number of dead forms, as to distribution on the fruit, and as to the spots caused by the parasites.

His investigations lead him to the general conclusion that all morphological characteristics (individual, specific, and generic) are associated with corresponding oecological or physiological peculiarities.

**Chemical Defence and Other Adaptations in North African Orthoptera.||**—J. Vosseler discusses the defensive adaptations of Orthoptera from the desert regions of North Africa,—where there is a high

\* Trav. Soc. Imp. Nat. St. Pétersbourg, xxxii. (1902) pp. 65-95 (1 pl.).

† Zool. Jahrb., xv. (1902) pp. 561-2 (3 figs.).

‡ Bull. Soc. Zool. France, xxvii. (1902) pp. 207-9.

§ Zool. Jahrb., xvii. (1903) pp. 237-84.

|| Verh. Deutsch. Zool. Ges. xii. Vers. (1902) pp. 108-21 (4 figs.).

degree of isolation, great drought, great heat, and sparse vegetation. Colour-resemblance between the exposed parts and the immediate environment is abundantly illustrated. But some forms (*Cedaleus nigro-fasciatus* De Geer and *C. senegalensis* Krss.) seem to be protected by a strongly-swelling secretion from a glandular vesicle beneath the pronotum,—a clear drop is exuded and can be re-absorbed. In others, e.g. *Eugaster guyoni* Serv., there is a blood-spraying apparatus at the junction membrane between coxa and trochanter on all the legs.

In another communication\* on the Orthoptera of Algiers and Tunis, Prof. Vosseler discusses (1) the relations of these to the Mediterranean-palæarctic-Orthoptera; (2) the markings and other adaptations of the Acridiidae; (3) the moulting of *Eugaster* and other forms, with especial reference to coloration; (4) the spermatophores of *Eugaster* and *Platystolus*; (5) the blood-spraying of various Locustidae; and (6) the malodorous glands of *Cedaleus*. The particularly successful illustrations of this paper are being sold separately,—a useful new departure.

**Sensory Hairs on Pupa of *Papilio podalirius*.**†—M. Gräfin von Linden finds projecting from various parts of the chitinous pupal sheath minute hairs; the base is connected by a fine nerve running through the chitin to a peripheral nerve-strand which lies between the pupal sheath and the epithelium covering the body. Internal to the epithelium there are more nerve-strands. The peripheral nerve-terminations outside the body are brought into connection with the outer world by the fine fibres running through the chitin to the projecting hairs. Perhaps the function is concerned with temperature. Perhaps the structures are genetically connected with sensory structures in the caterpillar stage.

**Appendicular Nature of Abdominal Styles.**‡—B. Wandolleck refers to the embryological evidence of Heymons that styles and cerci have an appendicular nature, and that the gonapophyses have not, and to Verhoeff's objection that the styles are always unjointed. In fact, Verhoeff was inclined to attribute a homology with limbs to the gonapophyses, but not to the styles.

Wandolleck describes and figures the styles of a female specimen of *Lagria hirta*, which have two joints. The same is true in *Omophlus lepturoides*. Thus Verhoeff's objection is answered.

**Trochanter and Præfemur.**§—K. W. Verhoeff maintains that the trochanter of Chilopoda is not homologous with what is so called in insects, that it is the equivalent of an overlooked joint in insects, distinct in some lower forms, more and more degenerate in higher forms,—a joint which should be called the præfemur. A true trochanter has two characteristics: (1) that it lies between two joints which are always larger than itself, and has always the coxa to its basal side; and (2) that it is without intrinsic musculature.

**Studies on the History of the Germ-Cells in Lepidoptera.**||—K. Grünberg first discusses the apical cell or Verson's cell which occurs at

\* Zool. Jahrb., xvii. (1902) pp. 1-98 (3 pls. and 5 figs.).

† Verh. Deutsch. Zool. Ges., xii. Vers. (1902) pp. 126-33 (7 figs.).

‡ Tom. cit., pp. 193-5 (2 figs.).

§ Zool. Anzeig., xxvi. (1902) pp. 205-14 (10 figs.).

|| Tom. cit., pp. 131-42 (4 figs.).

the tip of testicular and ovarian tubes. It arises from an original germ-cell, and is distinct from a very early date (even in the embryo in *Bombyx mori*). In the testes it contributes to the nutrition of the germ-cells, acquiring the necessary material partly by dissolution of spermatogonia, partly by assimilating material from the connective-tissue sheath of the testis, and partly by independent secretory production of nutritive substance. After it has done its work, it gradually degenerates. In the ovary the apical cell is practically functionless; in later stages it degenerates.

Grünberg also discusses the post-embryonic development of the ovaries in *Bombyx mori* and *Pieris brassicæ*. He finds that the differentiation of the germinal elements of the ovary begins during the larval period. The original oogonia give rise only to ova and nutritive cells. The follicular cells are due to a limited number of epithelial cells of the stalk of the ovarioles, distinctly separated from the germ-cells during the embryonic period.

**Notes on Liparids.\***—J. J. Lister refers to the vestigial character of the maxillæ in *Porthesia auriflua* and *Psilura monarcha*; they are not accurately opposable to form a proboscis and are shorter than the labial palps.

Sexual dimorphism is well marked in *P. auriflua*, secondary sexual characters being found in the "expansion" of the wings, colour, and the larger size of antennæ and eyes in the male sex. A paired longitudinal groove on the sides of the fourth abdominal segment of the male is probably homologous with the much longer groove found in the males of many *Noctuæ*, notably in *Xylophasia polyodon*, extending from the second to the fourth abdominal segment and lodging a remarkable protrusible tuft of hairs. The males of *P. auriflua* have very keen powers (olfactory?) of detecting the presence of the female. Death rapidly follows fertilisation.

The conspicuous satiny-white colouring of the three species *Porthesia chrysorrhæa*, *P. auriflua*, and *Liparis salicis* is contrasted with the quiet buffs, browns, and blacks of the other members of the family, conforming closely with their environment. There is considerable evidence that the conspicuous species are noxious, both in the larval and adult state, by reason of the urticating properties of the hairs.

**Beetles of Ireland.†**—W. F. Johnson and J. N. Halbert have produced the first published list of the Irish Coleoptera, including about 1630 species, none peculiar to the country. The authors distinguish three groups:—(a) species which range over central Europe and the Mediterranean region, but are rare or wanting in Scandinavia and northern Europe; (b) species of northern origin, a good many of which inhabit mountain districts; (c) species which are found almost exclusively in south-western Europe and the Mediterranean region, the exceptions being littoral species which range as far north as Scandinavia. Most of the Irish representatives of this third group are insects of the sea-shore. The authors think that about forty species in their list have

\* Proc. Cambridge Phil. Soc., xii. (1903) p. 16.

† Proc. R. Irish Acad., vi. (1902) pp. 535-827.

been introduced by human agency. They hope that their work—which is as welcome as it is useful—will stimulate fresh inquiries.

**Grapevine Root Worm.\***—E. P. Felt gives in a well-illustrated bulletin an account of the life-history and habits of the Chrysomelid beetle *Fidia viticida* Walsh, which has proved itself a destructive enemy of the vineyards in the Chautauqua grape belt. The natural enemies and the various remedial measures are duly discussed.

### β. Myriopoda.

**Structure of Myriopods.†**—G. Rossi has made a detailed study of *Julus* and *Scolopendra*, with notes on other forms. The first part of the memoir discusses the skeleton and musculature, the second is devoted to the body-wall, the third to the respiratory system, and the fourth to the vascular system and the cavity of the body. The development of the zonites and skin is also dealt with, the problem of the metamerism is discussed, and careful attention is given to the mechanism of respiration.

**Labial Excretory Organs and a Phagocytic Organ in Diplopoda.‡**—L. Bruntz has used the injection-method to discover the excretory organs of *Glomeris* and other millipedes. He finds four kinds of excretory organs:—(1) Uric cells in the adipose tissue; (2) nephrocytes around the perineural sinus; (3) the Malpighian tubules; and (4) labial organs. The last consist of a sacculæ which eliminates injected carmine and a labyrinth leading to the exterior on the gnathochilarium. He compares them with the antennary and maxillary excretory organs in some Crustaceans. A phagocytic organ which Cuénot demonstrated on each side of the perineural sinus has been found by Bruntz in various Julidæ.

### δ. Arachnida.

**Gamasus auris.§**—E. Trouessart gives an account of this interesting mite which lives as a commensal in the external auditory tube of cattle, feeding on the abundant cerumen. It is parthenogenetic, but two males were found in five hundred specimens. It seems to be sometimes oviparous, sometimes ovoviviparous. A careful study of the animal described in 1872 by Leidy as *Gamasus auris* has led Trouessart to establish for it a new genus *Raillietia*. In a note (in discussion) Racovitza calls attention to the mites (undetermined) found abundantly in the mucus of the nostrils in the Antarctic seal (*Lobodon carcinophaga*).

**Thick-skinned Acarina.||**—Sig. Thor shows that the thick skin is not a dead layer, but composed of many living elements diversely disposed. He describes in particular *Trombidium holosericeum*, *Arrenurus pustulator*, and *Lebertia obscura*, and gives a detailed account of the skin layers—epiostracum, ectostracum, hypostracum, and hypodermis.

\* Bull. New York State Mus., No. 59 (1902) pp. 49-84 (6 pls.).

† Ricerche Lab. Anat. Univ. Roma, ix. (1902) pp. 5-88 (1 pl. and 10 figs.).

‡ Comptes Rendus, cxxxvi. (1903) pp. 57-9.

§ Bull. Soc. Zool. France, xxvii. (1902) pp. 231-3.

|| Arbeit. Zool. Inst. Wien, xiv. (1902) pp. 291-306 (1 pl.).

## e. Crustacea.

**Nucleolar Changes in Secretion of Hepato-Pancreatic Cells of Hermit-Crab.\***—L. Launoy describes in the mid-gut gland of *Eupagurus bernhardus* the division of the nucleolus without subsequent nuclear division; the pulverisation of one or more of the nucleoli; the passage into the karyoplasm of inter-nucleolar granulations or the dissolution of these in the fundamental acidophilous substance of the nucleolus—a process which he sums up in the term *pyrenolysis*.

The phenomena of pyrenolysis, which are easy to follow in the hermit-crab because of the size of the cells, precede or accompany the appearance of the ergastoplasmic filaments. They therefore indicate that the nucleolus plays a very active part in the elaboration of the secretory granules.

**Function of Mid-Gut Gland of Crayfish.†**—H. Jordan sums up the results of experiments made by himself and others on the function of the so-called "liver" of *Astacus fluviatilis*. It forms digestive juice and absorbs food; it does not differ very greatly from the short mid-gut; it is, in fact, a mid-gut greatly increased by evagination and protected from hard bodies.

**Two New Types of Epicaridæ.‡**—J. Bonnier describes the external characters of a single specimen of a new form, *Cumoniscus kruppi* g. et sp. n., found by Lo Bianco in one of the Cumacea (apparently a new genus of Leuconidæ). A second new type, also represented by one specimen, was found in a Schizopod described by G. O. Sars under the name *Gastrosaccus normani*. From its resemblance to *Dajus*, Bonnier calls this second novelty *Prodajus lobiancoi*.

**Marine Species of Hyalella.§**—Ed. Chevreux describes a new amphipod *Hyalella richardi* sp. n., a marine species of a genus hitherto known only as represented by fresh-water forms from America. The new form was obtained by MM. Richard and Neuville on a cruise of the Prince of Monaco's 'Princess Alice' on the shore of the island of Alboran (between Spain and the Mediterranean coast of Morocco). The genus may be represented in the fresh waters of Morocco, but there seems no doubt that the new species is marine. Chevreux gives a description of both male and female forms.

**Crustacea and Pantopoda.||**—J. Meisenheimer gives a short account of the development of Pantopoda or Pycnogonids (especially *Ammotha echinata*) and discusses their systematic position.

The cleavage and the differentiation of an inner and outer cell-complex, the former including the elements of the mid-gut and of the muscular-connective system, the latter forming ectodermic structures, may be harmonised with similar phenomena in *Branchipus*, *Moina*, *Cetochilus*, and *Chondracanthus*. There is in all these a regular total

\* Comptes Rendus, cxxxvi. (1903) pp. 109-12.

† Verh. Deutsch. Zool. Ges., xii. Vers. (1902) pp. 183-6.

‡ Comptes Rendus, cxxxvi. (1903) pp. 102-3.

§ Bull. Soc. Zool. France, xxvii. (1902) pp. 223-7 (2 figs.).

|| Verh. Deutsch. Zool. Ges., xii. Vers. (1902) pp. 57-64.



cleavage, and the establishment of an inner layer, which in some cases, as in *Ammothoa*, forms a recognisable gastrula. The absence of a typical gastrula in *Ammothoa* leads us again to think of the lower Crustacea. But even closer are the resemblances between the Protonymphon-larva and the nauplius, which are discussed in detail.

Allowing that the nauplius has many cœnogenetic characters, Meisenheimer cannot agree with Dohrn that the only relationship between Crustaceans and Pantopods is in their common resemblance to an "Ur-Form," far below the roots of both classes. "The larval development of Pantopods points with great distinctness to a close relationship with Crustaceans."

#### Annulata.

Regeneration in Limicolæ.\*—Max Abel has reached the following conclusions as to regenerative capacity in limicolous Chætopods. The regeneration of the anterior end of *Tubifex* usually occurs only after the loss of fewer than 10–12 segments. The regenerated portion is divided only into three segments. After amputation of numerous segments there is in some rare cases development of regeneration-buds, but these do not usually come to anything.

In *Nais*, the regeneration of the anterior end is more frequent and more rapid than in *Tubifex*, and occurs after the removal of many segments as well as after the removal of a few. Six to eight segments were often observed in the new growth. In both genera, the head-ends do not regenerate a new tail-end unless they have at least 10–12 segments. In both cases the regenerative capacity is markedly less towards the posterior end.

Portions of *Tubifex* from the anterior (genital) region frequently form both anterior and posterior re-growths, while portions from the other regions, usually re-grow only the posterior end, or less frequently a normal anterior end. Portions of *Nais* from all regions of the body except the hindmost region regenerate anterior and posterior ends equally often. On the whole, the regeneration in *Tubifex* resembles that in Lumbricidæ, while *Nais* is more like *Lumbriculus*. The two last-named forms have a greater regenerative power, and this may be associated with their natural habit of asexual fission.

The author then discusses the regeneration of the alimentary system in particular. The lining of the new buccal cavity is ectodermic, but the pharynx is endodermic, thus differing from what occurs in ontogeny. The hind-gut is also regenerated from the ectoderm, but there are frequent deviations from the ontogenetic form.

Abel proceeds to describe the regeneration of the nervous system. The cut-end of the old ventral cord does not show any multiplication of nerve-cells, and the frequent slight divarication of nerve-fibrils to the body-epithelium is of subordinate importance in connection with the regeneration. In the regeneration the nervous elements arise exclusively from the ectoderm, which by proliferation forms an indifferent, somewhat embryonic formative material, subsequently differentiated into various structures, nervous and otherwise. In the regeneration, the

\* Zeitschr. wiss. Zool., lxxiii. (1902) pp. 1–74 (3 pls. and 2 figs.).

several parts of the system (brain, œsophageal ring and commissures) are not re-made separately, but from unified paired ectodermic primordia. The regenerative processes agree with the embryonic development in having this paired origin. The author has many general remarks of much interest, e.g. that the regeneration-process does not show any distinct mesoderm-differentiation.

**New Species of Alma.\***—O. Duboscq describes *Alma zebanguii* sp. n. from a tributary of the Oubangui, Africa. He directs special attention to the large solid paired penis with glands and suckers, to the diverticula of the œsophagus, to the typhlosole, to the clitellum, and to the setæ. He distinguishes three stages:—an immature form without penis, an adolescent form with penis but without clitellum, and a mature form with clitellum. The genus *Alma* includes five species, of which *Alma nilotica* alone has branchiæ and is palæarctic; the non-branchiate species are Ethiopian. Perhaps the genus should be split into two. Affinities with Glossoscolecidae seem certain, but perhaps it will be found necessary to make a new sub-family Alminæ for the African species.

**Hemiclepsis and allied Genera.†**—N. Livanow finds that the representatives of the genus of leeches known as *Hemiclepsis*, fall into two groups, one set grouped round *H. tessellata* and approaching the Glossosiphoniæ; the other set grouped round *H. marginata*, and in some respects approaching the Ichthyobdellids. For the former he proposes the new genus *Protoclepsis*, and describes four new species. The new genus is to some extent a connecting link between *Hemiclepsis* on the one hand and *Glossosiphonia* (along with *Placobdella* and *Hæmenteria*) on the other.

#### Nematohelminthes.

**Species of Rhabditis.‡**—A. Michel has tried to distinguish in his cultures some of the species in this difficult genus. He finds a hermaphrodite form, described by Vernet under Dujardin's title *Rh. terricola*, a name afterwards replaced (by Maupas) by the title *Rh. verneti*, since Dujardin's type was dioecious. He finds also a dioecious form, which is in many ways like *Rh. terricola*, but also like *Rh. dolichura* which is, however, smaller and oviparous. A third form seems to be *Rh. elegans* Maupas, and a fourth the parthenogenetic *Rh. schneideri*.

**Hind-End of Ascaris.**—E. Voltzenlogel has studied the posterior region of *A. megalocephala* and *A. lumbricoides*. There is a glandular ring round the beginning of the hind-gut, consisting of six cells in the male, of three in the female. The dilators of the chyle-intestine and the compressor of the ductus ejaculatorius are formed by the same muscle-cells, two in number.

The spicula are more than setæ. With their sheaths they represent a continuation of the body-wall, including both cuticula and sub-cuticula. The latter is the more important in the formation of the spicule.

\* Arch. Zool. Expér., x. (1902) Notes et Revue, No. 7, pp. xcvi.—cvi. (3 figs.).

† Zool. Jahrb., xvii. (1902) pp. 339-62 (1 pl.).

‡ Comptes Rendus, cxxxv. (1902) pp. 907-10.

§ Zool. Jahrb., xvi. (1902) pp. 481-510 (3 pls.).

Each spicule has its musculus exsertor, which is not a single muscle, but is composed of two components,—a plicator and a fixator of the sheath.

The lateral nerves and the dorsal nerve end in common in a caudal ganglion, which lies about the middle of the tail. From this in each lateral line a fine nerve-strand runs for a short distance backwards, innervating a somewhat lateral simple papilla. On the dorsal wall of the hind-gut, behind the anal ring, a nerve-strand runs backwards from the ring to the caudal ganglion.

#### Platyhelminthes.

*Echinococcus alveolaris*.\*—O. v. Linstow has reinvestigated this form from a pig's liver, which used to be regarded as a tumour (an alveolar colloid neoplasm). Many regard it as a distinct species of *Echinococcus*, but von Linstow gives good reasons for interpreting it as an abnormal modification of *Echinococcus polymorphus*. It arises from a form which has been smothered in hepatic tissue and half-starved. The scolex-formation is sparse or absent, and the number of hooks, which should be about thirty-six, may sink to ten. Von Linstow also describes *Plerocercus lachesis* sp. n., a Cestode from *Lachesis mutus*.

*Triplotænia mirabilis*.†—J. E. V. Boas describes a remarkable new tapeworm from the intestine of a "rock-kangaroo" (probably *Petrogale penicillata*). It consists of a scolex (with four suckers and no hooks), bearing two long puckered bands or strobilæ, in which the proglottides are not demarcated and the gonads occur in closely crowded succession. The presence of three shell-envelopes and of a pear-shaped process from the innermost envelope suggested relationship with the Anoplocephalinæ. The unarmed head is another resemblance, and the unilateral position of all the genital apertures brings this new form near the genus *Anoplocephala*. All the tapeworms hitherto described from Marsupials have been Anoplocephalinæ.

As four similar specimens were obtained, there can be no question of abnormality. It is true that abnormal Cestodes with lateral chains springing from the main chain have been described, but here the main chain is undeveloped and the accessory chains spring from the scolex. Another peculiarity is the absence of distinct proglottides, which sometimes occurs as an anomaly elsewhere. A third peculiarity is the difference between the two sides of the chain; one side is smooth and swollen, the other is thin and puckered,—a condition somewhat like that of *Tænia villosa* from *Otis tarda*.

*Cysticercus fasciolaris*.‡—E. Bartels gives in the first place an account of the structure of this bladderworm of the mouse, which hardly differs from the structure of the tapeworm of the cat (*Tænia crassicolis*) except in the absence of a terminal excretory bladder and of any hint of gonads. Even the jointing or segmentation is quite pronounced in the *Cysticercus*-stage. He describes successive stages in

\* Zool. Anzeig., xxvi. (1902) pp. 162-7 (14 figs.).

† Zool. Jahrb., xvi. (1902) pp. 329-34 (1 pl.).

‡ Tom. cit., pp. 511-70 (3 pls. and 2 figs.).

the development of this bladderworm of the mouse, and corroborates Küchenmeister's account of its transformation into the tapeworm of the cat, which was more accurate than Leuckart's. Almost the entire length of the bladderworm, except the bladder and the part immediately adjacent, passes over into the tapeworm stage.

**Minute Structure of Cysticerci.\***—P. Rössler gives a histological account of the cuticle and the subjacent epithelium that forms it, the parenchyma, and the musculature in *Cysticercus tenuicollis* and *C. fasciolaris*.

**Distomum clavatum.†**—H. von Buttel-Reepen points out that this name covers a group of species parasitic in fishes (Scombridæ). He takes a survey of the group and gives a detailed account of two new species,—*D. ampullaceum* probably from *Coryphæna* (though reported by the collector as from a Cetacean), and *D. siemersi* from the stomach of *Sphyræna barracuda*, the first Trematode reported from this fish.

**American Representatives of Distomum cygnoides.‡**—J. Stafford shows that there occur in American frogs and toads no fewer than five distinct species of what should (after Looss) be called the genus *Gorgodera*. He gives diagnoses and figures of these.

**Contributions to Study of Bipaliidæ.§**—J. Müller has investigated the copulatory apparatus of *Bipalium virile*, *B. graffi*, *B. böhmigi*, *B. penzigi*,—four new species. He has also studied *B. megacephalum* sp. n. and *B. robiginosum* v. Graff. The most striking general result is the great diversity in the copulatory apparatus as compared with other systems, but this is characteristic of terrestrial Tricladæ and of many other groups of animals. It is noteworthy that species inhabiting the same area are often very different in their copulatory organs, while those inhabiting separate areas are often somewhat similar. There may be here some relation to reproductive isolation, i.e. to the prevention of intercrossing.

**Fresh-water Polyclad.||**—R. Ritter von Stummer-Traunfels describes as *Shelfordia borneensis* g. et sp. n. a new form of Leptoplanid, interesting in its marked structural divergence from all other known genera in this family, but even more interesting as the only Polyclad known to occur in fresh water. It was found by R. Shelford in stagnant pools in Borneo.

**Callinera bürgeri.¶**—D. Bergendal completes his account of this divergent Palæonemertine. As regards the epithelium, the integumentary muscular layer, the disposition of the blood-vessels, the position of the mouth, the structure of the brain and lateral cords, the nature of the gut and gonads, *Callinera* agrees generally with the Palæonemertines. As regards the position of the brain and nerve-cords, it agrees especially with the Protonemertines.

The most important peculiarities are the following :—(1) The pointed

\* Zool. Jahrb., xvi. (1902) pp. 423-48 (2 pls. and 4 figs.).

+ Op. cit., xvii. (1902) pp. 165-236 (5 pls. and 8 figs.).

† Tom. cit., pp. 411-24 (1 pl.).

§ Zeitschr. wiss. Zool., lxxiii. (1902) pp. 75-114 (3 pls. and 3 figs.).

|| Zool. Anzeig., xxvi. (1902) pp. 159-61.

¶ Acta Univ. Lund, xxxvii. No. 2 (1901) pp. 49-118 (2 pls. and 25 figs.).

head, not marked off from the body, with subterminal proboscis-opening, and with the mouth opening just behind the brain; (2) the absence of special cerebral organs and the presence of contractile lateral organs; (3) the strong development of the brain, and especially of the dorsal ganglia, whose fibrillar nuclei are for a considerable extent directly apposed to the matrical layer, and the shortness of the ventral cerebral commissures; (4) the development on the head only of a strong nervous layer; (5) the unpaired œsophageal nerve; (6) the thinness of the matrical layer and its very constant and regular lenticular swellings outside the nerve-cords; (7) the four bundles of longitudinal muscles and the annular muscles in the fore-gut division of the proboscis; (8) the enormous strength and peculiar form of the posterior end of the proboscis-sheath; and (9) the disposition of the blood-vessels above the gut in the fore-gut region.

The classification proposed is:—

Fam. Carinellidæ M'Intosh.

Sub-family 1. Carinelleæ Bergendal, incl. *Carinina* Hubrecht and *Carinella* Johnston.

Sub-family 2. Callinereæ Bergendal, incl. *Callinera* Bergendal.

#### Incertæ Sedis.

*Ptychodera erythræa* from the Red Sea.\*—C. B. Klunzinger extends Spengel's account of this species. Some of its chief characters may be summed up—considerable size, conical proboscis, a grape-like appendage on the ventral surface of the proboscis stalk, cylindrical collar and trunk, very large genital ridges sinuous marginally, long branchial region.

#### Rotifera. ¶

New Male Rotifers.†—W. Wesché describes and figures the males of *Triarthra longiseta*, *Notommata naias*, and *Notops hyptopus*, not before recorded, and in addition a male Rotifer having jaws which the author has not been able to identify. †

#### Echinoderma.

Rearing Later Stages of Echinoid Larvæ.‡—L. Doncaster used four-litre jars secured from dust, supplied with fresh sea-water (brought from some distance from land) about five times a week, with or without plunger, and kept cool in the hot weather by a slow stream of running water. The results obtained differed very greatly according to the species; *Sphærechinus granularis* and hybrids with this species never developed further than the stage reached about the eighth day, although they sometimes lived for three weeks; *Strongylocentrotus lividus* and *Echinus microtuberculatus* and hybrids between them were reared to the young urchin stage. The hybrid urchins, which for some reason do not occur in nature, lived for a few days.

\* Verh. Deut.-ch. Zool. Ges., xii. Vers. (1902) pp. 195-202 (4 figs.).

† Journ. Quekett Mic. Club, viii. (1902) pp. 323-30 (2 pls.).

‡ Proc. Cambridge Phil. Soc., xii. (1903) pp. 47-9.

## Cœlentera.

**Structure and Development of Flabellum.\***—J. Stanley Gardiner discusses the genus *Flabellum* and the species *F. pavoninum* and *F. rubrum*. He gives an account of the general and minute structure of *F. rubrum*, and some notes on its post-larval development. In *F. rubrum* there appear to be three distinct specific or discontinuous variations.

Noteworthy in the larval development is the occurrence of a mouth almost as large as that of the calicle, and without tentacles or stomodæum. The stomodæum of the adult is probably formed by the external body-wall growing inwards, catching up the edges of the mesenteries in its progress, until it finally reaches the mesenterial filaments, which fuse together and help to make the stomodæal wall. The larval conditions—probably brought about by an enormous enlargement of the gastropore in the first place—is perhaps related to the need for rapid growth and abundant nutrition, which might be assisted by a widely open mouth. It is a larval character, not a palingenetic recapitulation.

**Notes on Variation, Protandry, and Senescence in Flabellum.†**—J. Stanley Gardiner finds that *F. stokesi* and *F. nutrix* are varieties of *F. rubrum*, the three forms illustrating discontinuous variability in the same area. When the polyps are 15–17 mm. in length, all the mesenteries have testes, and those on the larger mesenteries are functional. With increase of size beyond 25 mm. in length, the ova ripen, and the ovaries replace the testes.

The author discusses signs of senescence (?) in *Flabellum* and *Madrepora*, and suggests that the operative cause is probably the same as that which ultimately produces the death of our forest trees. He thinks that senescence is a general phenomenon in animal life, though definite evidence of this is scarce. He also inquires whether the dying away observed in particular species of coral over large areas may be comparable to the death of the bamboo after flowering. But no conclusion can be come to without more facts.

**New Pennatulacea and Gorgonacea.‡**—Th. Moroff has worked over the Pennatulacea in the museum at Munich, and describes several new species, two of *Pteroides*, one of *Pennatula*, one of *Ptilosarcus*, one of *Virgularia*, two of *Pavonaria*, one of *Acanthoptilum*, and one of *Cavernularia*. He also describes from Japan *Pleurocorallium confusum* sp. n., *Pleurocoralloides* g. n., *Paramuricea procera* sp. n., and *Plexurooides asper* sp. n.

**Studies on Graptolites.§**—Sv. L. Törnquist describes forms of *Didymograptus*, *Isograptus*, and *Mæandrograptus* from the lower zones of the Scanian and Vestrogothian Phyllo-Tetragraptus beds. In *Didymograptus* (sensu strictiori), the cavity of the ramifying portion of the

\* Marine Investigation in South Africa, ii. pp. 117–54 (4 pls.).<sup>1</sup>

† Proc. Cambridge Phil. Soc., xi. (1902) pp. 463–71.

‡ Zool. Jahrb., xvii. (1902) pp. 363–410.

§ Acta Univ. Lund, xxxvii. No. 5 (1901) pp. 1–32 (3 pls.).

first theca passes gradually into the common canal of the primordial stipe as well as into the apertural part of the theca. In *Isograptus*, the cavity of the ramifying portion of the first theca passes gradually into its apertural part, but into the common canal of the primordial stipe by means of a very constricted foramen placed near the prolific side of the sicula. In *Mæandrograptus*, the cavity of the ramifying portion of the first theca is in direct communication with two or three thecae of the primordial stipe. Of the two last-named genera, established by Moberg (1892), only one species is known. They are very distinct from *Didymograptus*, but perhaps they should be ranked as sub-genera. Törnquist describes eight new species of *Didymograptus*.

Protozoa.

*Cymbalopora bulloides*.\*—A. Earland has paid particular attention to the final inflated portion of the shell of this Foraminifer, the so-called "balloon" chamber, and finds that it incloses another very delicate chamber, the "float" chamber. This inner chamber has a very delicate imperforate calcite wall, it is not attached to the inner surface of the balloon chamber. It is attached to the lower surface of the upper or spiral shell, but has no direct connection with these upper chambers, the only opening into its interior consisting of the small tube in the centre of its base, as discovered by Möbius.

New Coccidian.†—M. Siedlecki has found in the mature males of the Polychæt *Polymnia nebulosa* a large Coccidian which he calls *Caryotropha mesnili* g. et sp. n. Like other Coccidia, it is an intracellular parasite, and occurs in the packets of spermatogonia, never more than one in each. The "indifferent adult" form may multiply by division into merozoites (mononts, schizonts), or it may reproduce sexually. In the first case the Coccidian does not leave its hypertrophied cell-host, it gives rise to *m* "*Monontocytes*" which produce *m n* Mononts, whence adults develop. The sexual reproduction may be summed up as follows :—

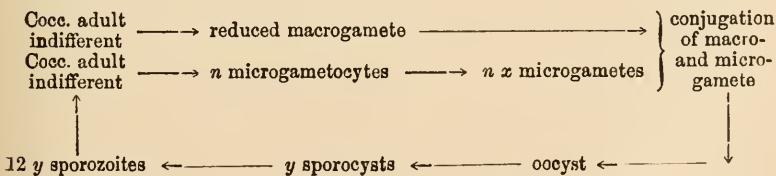

\* Journ. Quekett Micr. Club, viii. (1902) pp. 309-22 (1 pl. and 3 figs.).

† Bull Internat. Acad. Sci. Cracovie, No. 8 (1902) pp. 561-8 (5 figs.).



## BOTANY.

## GENERAL,

Including the Anatomy and Physiology of Seed Plants.

## Cytology,

including Cell-Contents.

**Specific Gravity of Cell-sap.\***—Gustav v. Walk has studied the specific gravity of the cell-sap in different parts of the plant; his observations have extended over a large number of species. The limits of concentration were represented by a specific gravity of 1·099 and 1·007. In 34 determinations of the specific gravity of growing shoots (from which leaves and apical bud had been removed) of seven plants, including three species of *Rumex*, *Polygonum cuspidatum*, and *Sambucus nigra*, the numbers varied from 1·012 to 1·024. The difference between the specific gravity of sap from succulent leaves, and that from ordinary mesophyte foliage was not great. In the former (eight plants, chiefly Crassulaceæ) it ranged from 1·013 to 1·028, in the latter from 1·015 to 1·044. This is associated with the fact that succulent leaves store not only water but also matter in solution. In special reserve stores (sixteen specimens) a variation occurred from 1·014 in tubers of *Mirabilis* to 1·08 in the rhizome of *Cochlearia Armoracia*. In fruits (seventeen examples) the lowest concentration was in *Cucurbita melanosperma*, 1·013, the experiment being made with the parenchymatous tissue of a fruit which had been kept through the winter; the highest result was obtained with berries of *Berberis vulgaris*, namely 1·073. Kraus had previously recorded a specific gravity of 1·08 in *Lonicera tartarica*.

A comparative examination was also made at different times of the day, with transpiring plants. Thus in *Rheum officinale* at 6 a.m., 3 p.m., and 6 p.m. the numbers were respectively 1·015, 1·018, and 1·015, and with *Heracleum pubescens* 1·019, 1·034, 1·028. The concentration in the leaves in summer was less than that in autumn: thus in *Sambucus nigra* the results were, in June 1·020, in October 1·056.

**Arsenic in Plants and Animals.†**—Armand Gautier finds arsenic in a number of algæ, especially seaweeds (species of *Fucus*). He remarks that the association of arsenic and iodine in seaweeds is paralleled by a similar association in animal organs (hair, skin, thyroid, &c.). He also finds arsenic in the boghead of Autun and Australia, which M. Renault has shown to contain spores of fresh-water algæ. The bacteria of sulphur springs were also found to contain both arsenic and iodine, and arsenic was isolated from the plankton of sea-water. The source of the arsenic which is thus shown to be assimilated by plant and animal organisms is presumably the sediment derived from the primitive rocks. The author found that arsenic always accompanies iodine, nitrogen, and phosphorus in these rocks, and thus appears to play a universal part like nitrogen and phosphorus.

\* Zeitschr. f. angew. Mikr., viii. (1902) pp. 141-64.

† Comptes Rendus, cxxv. (1902) pp. 833-8.



**Localisation of Daphnine in *Daphne Laureola*.**\*—W. Russell finds that the glucoside daphnine is localised, in the stem and leaf of the plant, in the epidermis, in the parenchyma and in the fibres of the primary bast; in the secondary bast it occurs in these elements and also in the medullary rays; in the wood it occurs in the medullary rays. The root, which is rich in starch, contains but little of the glucoside; the author detected it in the periphery of the cortex, and in the bast of young roots, but was not able to certainly recognise it in old roots. All the members of the flower contain it, its distribution resembles that in the foliage leaves, but it predominates in the epidermis. It also occurs in the integuments of the ovule and in the nucellus in the neighbourhood of the chalaza. The glucoside can easily be made to crystallise in situ, by placing leaf or stem in alcohol and tartaric acid for 24 hours with subsequent evaporation. The crystals are grouped in roundish masses and show the radiating arrangement which is observed in spherocrystals of inulin. Daphnine is always accompanied by oily matters.

### Structure and Development.‡

#### Vegetative.

**Evolution of Vascular Tissue.**†—W. C. Worsdell gives a short general survey of the various types of arrangement of the vascular tissue in plants and suggests a course of evolution of the types characteristic of the higher plants from those found in the lower. The prototype is sought in the solid stele (protostele) consisting of a central mass of xylem surrounded by a ring of phloem. This structure always appears as the first stage in the individual development in the fern group, and also in the mature vascular structure of several of the most primitive ferns such as Hymenophyllaceæ and, among the fossils, *Botryopteris*. In the next stage a pith arises in the centre of the solid stele; examples occur in *Platyzoma* (Gleicheniaceæ), *Schizæa*, and others. The protoxylem is situated at, or a short distance within, the periphery of the metaxylem, the development of which is chiefly centripetal. In the third stage, the solenostele, an internal zone of phloem is added, as in various Schizæaceæ, and *Medullosa stellata* among the Cycadofilices. The next condition, the dialystelic, results from the splitting of the solenostele into a number of solid steles or concentric strands, the protoxylem being still at or near the external limits of the xylem. This structure is due to the crowded arrangement of the leaves in the stem, necessitating frequent gaps in the original solenostele, to allow of the passing out of the leaf-trace bundles. Both conditions belong essentially to the siphonostelic or tubular type of stele. Dialystely is very common in ferns, occurring in almost all the Polypodiaceæ which represent the most advanced type of the series. It also occurs in several of the Cycadofilices, such as the *Medullosæ* and *Cladoxylon*. The gymnospermous type arose by the gradual reduction of the concentric to the collateral type by reduction of the tissue on its inner side, whereby the phloem and the whole of the secondary wood on that side vanished, leaving the

\* Rev. Gén. de Bot., xxxiv. (1902) pp. 420-6.

† Bot. Gazette, xxxiv. (1902) pp. 216-23 (7 figs. in text).

mesarch bundle consisting of a protoxylem with a group of primary metaxylem on its inner and outer side. This type occurs in the peduncle of the cone in *Stangeria* and *Bowenia*, in the leaves of *Cordaites* and modern cycads, and in the cotyledons of *Gingko* and *Cephalotaxus*. But in the stems of modern cycads, and the still more recent Coniferæ, it has given place to the endarch type in which the inner centripetal group of xylem has disappeared, so that the protoxylem now forms the most internal portion of the bundle nearest the pith. But stems of certain fossils—*Pitys*, *Calamopitys*, and *Dadoxylon*—still retain the older mesarch type. In the foliage leaves of conifers the centripetal primary xylem is modified to form the transfusion tissue. In the highest group, the angiosperms, all trace of the old mesarch structure has vanished both in stem and leaf, and the purely endarch structure prevails everywhere.

**Histology of the Wood in Species of Pines.\***—K. E. Golden has examined thirteen species of pine, to determine, if possible, what peculiarity of structure produces the variations in quality of the wood. The results of the measurements of length, breadth, and thickness of wall of the tracheides, the characters of the wood, including its distribution between spring and summer formation, the distribution of resin-canals, the nature of the medullary rays, and the weight, strength, density, grain, and quality of the wood are given in a series of tables. Examination of the figures shows that there are six species in which the spring wood tracheides are longer than those of the summer, while seven species have the summer tracheides the longer. The species in each group show variations in hardness and strength, so that taking the length of the tracheides as a factor by itself nothing can be deduced in regard to the quality of the wood, but taking the length and comparing it with the width of the cells, and again comparing the width and the thickness of walls together, and the amount of the spring and summer wood, the strength can be determined within limits in each species.

**Pilostyles Ingæ.†**—W. Endriss describes the morphology and development of this parasitic seed-plant. The vegetative "thallus" grows in the intercellular spaces of the host-plant or penetrates its cells. The flowers arise exogenously. The male contains two ring-like structures with 18 to 20 pollen-sacs in each, standing above a rudimentary ovary. The ovary in the female flowers contains usually five placentas bearing anatropous ovules. Normal fertilisation was not observed.

#### Reproductive.

**Development of the Embryo of some Dicotyledons.‡**—B. Schmid finds that in detached seeds of *Eranthis hiemalis*, *Corydalis cava*, and *Ranunculus Ficaria* the embryo continues its development throughout the whole summer and autumn. Development depends only on favourable physical conditions, and not on any special quality of the soil. Germination goes on in the open, influenced by the weather, from December to March; the seedlings are always free from mycorrhiza.

\* Proc. Indiana Acad. Sci., 1901 (1902) pp. 292-7.

† Flora, xci. (1902) pp. 209-36 (1 pl.).

‡ Bot. Zeit., lx. (1902) pp. 207-30 (3 pls.).

The development of the cotyledon in *Corydalis* and *Ficaria* is on the same lines in the two genera; there is scarcely a trace of a second cotyledon. In *Corydalis cava*, *C. nobilis*, and *C. lutea* a considerable increase in the endosperm takes place before germination. Idioblasts occur in very young embryos.

**Morphological Study of Thuja.\***—W. G. Land has studied the gametophyte stage, fertilisation, and embryology in *Thuja occidentalis* in the vicinity of Chicago. No prothallial cells could be demonstrated in the pollen-grain, the next step after the separation of the tetrads being the organisation of a tube nucleus and a generative cell. Before the appearance of the archegonium initials the penetration of the pollen-tube is relatively slow, but now becomes rapid, the tube piercing the remaining rows of nucellar cells and spreading over the archegonia absorbs the remnants of the neck-cells and lays bare the upper ends of the eggs. The body-cell divides into two equal and functional male cells.

There are generally six archegonium initials; the neck consists of two to six cells formed by anticlinal divisions only, they are soon almost entirely absorbed by the central cells. Protoplasmic connections between the jacket cells and central cells were not seen. A ventral nucleus is cut off and lies free in the cytoplasm in the upper part of the egg. When an archegonium has not been fertilised there are indications that the ventral nucleus divides. There are frequent instances of a further (mitotic) division after fertilisation, and there is evidence that both the ventral nucleus and the egg in an archegonium may be fertilised.

In most cases the tube and stalk nuclei from the pollen-tube do not enter the egg but disorganise in the space above the archegonia. The fusion nucleus is in general below the centre of the egg where it remains until the first division is completed. The two nuclei then sink to the bottom of the egg and divide simultaneously, while the ventral has enlarged considerably and is quite conspicuous. Eight free nuclei are formed in the proembryo which become separated by a transverse wall into two groups, each of four nuclei; the nuclei of the lower group are completely walled in and from these the single embryo develops. The upper nuclei are exposed to the cytoplasm above. The latter divide to form two tiers, the lower of which elongates to form the four suspensors by which the embryo is thrust down into the endosperm.

**Fruit of *Jacquinia ruscifolia* and Trichomes in Myrsinaceæ.**†—L. A. Mennechet describes the anatomy of the fruit and the histology of the pericarp and seed of *Jacquinia ruscifolia*, and also the structure and development of the hairs, glandular and non-glandular, in this and other genera and species of the order Myrsinaceæ.

### Physiology.

#### Nutrition and Growth.

**Influence of Carbonic Acid Gas on Growth.**‡—P. Chapin finds that the optimum amount of CO<sub>2</sub> in the air for growth in the higher

\* Bot. Gazette, xxxiv. (1902) pp. 249-58 (3 pls.).

† Journ. de Bot., xvi. (1902) pp. 349-57 (3 figs. in text).

‡ Flora, xci. (1902) pp. 348-79 (1 pl.).

plants is about 1 to 2 p.c. Growth of the root began to be checked with 5 p.c.  $\text{CO}_2$ , and was stopped with 25 to 30 p.c., in the case of the stem the percentages were 15 and 20 to 25 respectively. In the case of seedlings of barley, an exposure for 24 to 48 hours to 25 to 40 p.c. of the gas exercised no recognisable injurious effect on the root, while the stem was able similarly to resist an exposure for the same period to a 20 p.c. atmosphere.

Spore-germination was inhibited by 60 p.c.  $\text{CO}_2$  in the case of *Mucor*, 100 p.c. in the case of *Aspergillus* and of *Penicillium*, while growth of *Mucor* was checked in an atmosphere containing 30-40, and the other two moulds in one containing 80 p.c. of the gas. Ripe spores were formed as long as the amount of  $\text{CO}_2$  did not exceed 10 p.c. in the case of *Mucor*, 50 p.c. in the case of *Penicillium*, and 40 p.c. with *Aspergillus*.

✓ Nitrogen Assimilation in Moulds.\*—F. Czapek has studied the utilisation of amines, amides, and ammonium salts in the production of proteids in *Aspergillus niger*. Suitable sources of nitrogen were found among primary, secondary, and tertiary amines, whilst quaternary ammonium compounds are very injurious. The suitability of alkylamines as a source of nitrogen increases with the amount of carbon and the molecular weight. Isomeric compounds show marked differences; the presence of hydroxyl groups is favourable. Acetamide and propionamide are good sources of nitrogen, whilst the other amides of the series are unsuitable. Amides of dibasic acids gave good results. Nitrites are on the whole unsuitable. Amidines are good sources. Urea and its derivatives are inferior to amino-acids and alkylamines. Ammonium salts of the acetic acid series are not on the whole suitable as sources of nitrogen, whilst the salts of the oxalic acid series proved to be very suitable. Good results ensued with ammonium oxalate when carbon was supplied in the form of sugar.

‡ Effect of Composition of Soil on Plants.†—H. B. Dorner studied the effect of difference of soil, namely loam, clay, and sand on a few common plants,—carnation, chrysanthemum, geranium, bean, corn, and onion. The differences are more marked in the gross than in the minute structure, being general in the former for all the plants studied, while changes in minute structure are more specific in nature. The effect of a heavy clay upon a plant is almost the same as that of sand. This may be partly explained by the fact that although a clay soil is very rich in plant foods, the roots find such difficulty in penetrating it that the greater part is unavailable. A change in soil from loam to sand was found to produce a decrease in general size, and also in leaf-surface, length of petioles, diameter of stem, and length of internodes, also a decrease in the mass of roots, except in the onion; if, however, the size of the plants be considered, the mass of roots of plants in the sand was always relatively the greatest. Thus the plants in the sand have a stunted growth above soil and an increased growth in the soil. This is also true of the clay, but to a less extent than of the sand. The clay

\* Beitr. Chem. Physiol. Path., 1902, ii. pp. 557-90. See also Journ. Chem. Soc., lxxxiv. (1903) ii. p. 35.

† Proc. Indiana Acad. Sci., 1901 (1902) pp. 284-90 (2 pls.).

soil gave a very dark-green leaf, while that in the sand was of a sickly yellowish-green.

The changes in histological structure may be summed up as follows. A decrease in the transpiring surface and in the relative size of the woody tissue of the root in a change from the loam to the sand. A larger number of crystals for the clay soil than for the other two. A greater wood-development in the loam. Variations in the number of stomata were specific and not general. In some cases the loam had the highest average, in others the clay, but in most cases the sand. In five cases out of the six, the loam gave the thickest leaves; in the case of carnation the clay gave the greatest average. This increase in thickness was caused by a general increase in thickness of all the tissues. Plants growing in the loam had the smallest number of trichomes.

**Variation in Carbohydrate Reserves in Stem and Root of Woody Plants.\***—Leclerc du Sablon has investigated the variation in the amount of sugars and starch in the course of the year in certain trees. He finds that the amounts reach the minimum in the spring, when reserve material is being used up by rapid vegetation, and attain a maximum in autumn at the end of the vegetative period. It is interesting to note that during winter when growth is apparently at a standstill, the reserves diminish slightly. This may be due in part to their change into substances which are not transformable into glucose under the conditions of the experiment. Generally speaking, the root contains more reserve-stuff than the stem. The experiments were made with the chestnut, the pear, the peach, and the willow.

#### Irritability.

**Functional Inertia of Plant-Protoplasm.†**—R. A. Robertson reviews a number of phenomena which illustrate the fact that plant-protoplasm, like animal protoplasm, possesses functional inertia. The latent period and period of after-effect, which respectively precede the response to a stimulus and persist after its withdrawal, are examples. As a wheel in virtue of its inertia of motion continues to rotate for a time after the driving gear is slipped, so isolated organs or their parts may for a time manifest functional activity. Thus isolated chloroplasts continue to assimilate, and the nuclei of staminal hairs of *Tradescantia* carry on karyokinetic division after death of the protoplasm. In the acquirement of new characters by living matter it is suggested that functional inertia is a factor of importance.

**Movement of Perianth Leaves of Tulip and Crocus.‡**—A. Burgerstein finds when flowers of crocus and tulip are exposed to a relatively high and constant temperature, that the opening movement of the perianth leaves proceeds for a short time with increased and then with diminished speed, thereby confirming previous observations by Jost. In opposition to Pfeffer, who explained such movements by unequal

\* Comptes Rendus, cxxxv. (1902) pp. 866-8.

† Proc. Roy. Soc. Edinb., xxiv. (1902) pp. 200-4.

‡ Jahresb. d. k. k. Erzherr. Rainer-Gymnasiums, Wien, 1902. See also Bot. Centralbl., xc. (1902) p. 665.

growth on the two surfaces of the leaf, the author finds that the flowers of tulip and species of crocus show opening movements above the maximum temperature for growth, and closing movements at temperatures below the growth-minimum; also that the movements occur in rarefied air (20 mm. barometric pressure) and in pure oxygen, hydrogen, and carbonic acid gas, and even in watery solutions of different salts which may even be injurious to the plant, provided that the concentration is not sufficient to cause plasmolysis. The author concludes that alterations of turgidity in the tissue of the perianth leaves are the cause of the movements.

**Thigmotropic Root-Curvatures.\***—F. C. Newcombe has repeated Sachs' experiments on the curvature of roots caused apparently by pressure, and finds that the result varies according to the material of which the small rods applied to the root-tip is made. Pins made of oak or of the wood of yellow pine caused a strong bending towards the side in contact in roots of maize, lentil, bean, and others, but no result followed when wood of the white pine or of the tulip-tree, or glass, was used. The author concludes that it is not the pressure of the attached object which causes the bending of the root, but probably substances injurious to the root which are imparted by the attached object. That is to say, the supposed thigmotropic curvatures are traumatic.

**Influence of Loading on the Formation of Wood and Bast Elements in Weeping Trees.†**—W. Wiedersheim, experimenting with normal individuals and weeping varieties of ash, beech, mountain ash, hazel, and wych elm, finds a shortening of the wood-cells in the loaded branches. No other effect was produced on the wood. In the hazel alone, the bast-ring was more strongly developed, and there was also an increase in the number of stereides.

#### Chemical Changes.

**Sugar in Ripe Fruits.‡**—A. de Muynck has analysed varieties of ripe pears during the winter months, and finds that levulose is always greatly in excess of glucose. The former varies from 70 to 93 p.c. of total sugar, the latter from 7 to 30 p.c. He suggests the possibility of a fermentation process by which the glucose is attacked, in order to explain this great difference between the percentages in the two cases.

**Formation of Asparagine in Metabolism.§**—U. Suzuki finds, as a result of experiments with barley and beans, that there was an increase of asparagine in the shoots only when oxygen was present, whereas decomposition of proteid goes on in absence as well as in presence of oxygen.

**Lime in Phanerogamic Parasites.||**—K. Aso finds evidence to support the view that the presence of chlorophyll influences the relative

\* Beih. z. Bot. Centralbl., xii. (1902) pp. 243-7.

† Pringsh. Jahrb., xxxviii. (1902) pp. 41-69.

‡ La Cellule, xviii. fasc. 2, pp. 441-5.

§ Bull. Coll. Agric. Tokyo Imp. Univ., iv. (1902) pp. 351-6. See also Journ. Chem. Soc., lxxxii. ii. (1902) p. 684.

|| Bull. Coll. Agric. Tokyo Imp. Univ., tom. cit., pp. 287-9. See also Journ. Chem. Soc., l.c.

amount of lime in the ash of plants. While the ash of *Cruscula europæa* contains only about 2 p.c. of lime, that of the clover, its host, contains more than 30 p.c. This taken in conjunction with Palladin's observation that etiolated leaves of *Vicia Faba* contain less lime than green leaves, and the fact that seedlings generally require less lime before than after they have chlorophyll, suggests that not only the nuclei but also the chlorophyll-bodies require lime. The author also investigated the colourless saprophytic orchid *Gastrodia elata* in this connection, and finds that the ratio of lime to magnesia in the above-ground parts is 1 : 1, as compared with flowering cereals 2 : 1 and lucerne 8 : 1.

**Composition of Seeds of Ginkgo biloba.\*** — U. Suzuki finds that the dry matter of the seeds freed from the testa have the following percentage composition :—Total nitrogen 1·8, proteid nitrogen 1·4, crude fat 2·6, lecithin ·17, crude fibre 1·2, starch 62·4, sucrose 5·2, reducing sugar 1·4, ash 3.

#### General.

**Chinese Flora.†**—The continuation of Forbes and Hemsley's enumeration of Chinese plants includes the small orders, Hydrocharideæ and Burmanniaceæ (by C. H. Wright) and the Orchidaceæ, which have been elaborated by R. A. Rolfe. A number of new orchids are described, including a new genus, *Hancockia*, the majority of which were contained in Augustin Henry's recent collections.

**Strand Flora of New Jersey.‡** — J. W. Harshberger makes some notes supplementary to his 'Ecological Study of the New Jersey Strand Flora,' published in the *Proceedings* of the Academy for 1900.

### CRYPTOGAMS.

#### Pteridophyta.

**Primary Structure of certain Palæozoic Stems.§** — D. H. Scott concludes, from an examination of certain stems from the Lower and Upper Carboniferous strata, that distinct, usually mesarch strands of primary xylem forming the downward continuations of the leaf-traces, were present around the pith in a number of palæozoic stems with secondary wood of *Dadoxylon* structure. Thus the anatomical structure, of which we may take *Lyginodendron Oldhamium* as the type, proves to have been widely distributed among palæozoic plants, and to have extended to stems which, on the basis of other characters, would have been referred with some probability to the Cordaitææ. The stems examined represent three groups :—

(1) The *Calamopitys* group, characterised by the relatively large size and distinct mesarch structure of those primary xylem-strands which are about to pass out from the pith, while the same strands, lower in their course, are reduced in size and may assume endarch structure by failure of the centripetal wood. A single strand passed out from the pith to

\* Op. cit., pp. 357-8. See also Journ. Chem. Soc., l.c.

† Journ. Linn. Soc., xxxvi. (1903) pp. 1-72.

‡ Proc. Acad. Nat. Sci. Philad., 1902, pp. 642-9 (figs. in text).

§ Trans. Roy. Soc. Edinb., xl. (1902) pp. 331-65 (6 pls. and figs. in text).

form the leaf-trace. The pith is solid, with no trace of discoid structure, and very variable in size. The secondary wood has the typical *Dadoxylon* structure; the medullary rays are one or two cells in thickness.

(2) The *Pityis* group with numerous small xylem-strands around a large pith, in which they are more or less deeply imbedded; their structure is generally mesarch. The leaf-trace passes out as a single strand. The pith is large and may show some approach to discoid structure. The secondary wood has the typical characters of the *Pissalendron* subgenus of *Dadoxylon* with rather wide elements; the larger medullary rays are always pluriseriate.

(3) The type of *Dadoxylon Spencersi* with a few small primary xylem-strands scattered at the pith margin and closely applied to the secondary wood, of mesarch structure, and passing out in pairs, each pair constituting a single leaf-trace. The pith is of moderate size and probably not discoid. The secondary wood is of the usual *Dadoxylon* type but very dense, consisting of small tracheides, with medullary rays generally of one cell in thickness.

As regards their affinities, the stems referred to *Calamopitys* are very suggestive of Cycadofilices, owing to the great development of the primary xylem-strands, and the marked similarity to the structure of *Lyginodendron*. They differ from the latter in the structure of the petiole which approaches that of a *Myeloxylon*. The tendency towards an endarch structure in the lower part of their course suggests that this group had advanced further towards the usual stem structure of Gymnosperms than had *Lyginodendron* or even *Poroxyton*. Of interest also is the narrow-rayed secondary wood, quite Cordaitean or Araucarian in structure.

*Pityis* were tall branching trees, a habit which is incompatible with Cycads or Cycadofilices, and the only known family to which they could be referred is the Cordaiteæ, leaves of which have been found at a similar horizon. They differ in having broad medullary rays and a non-discoid pith and in the presence of the primary xylem-strands, and are probably to be regarded as a primitive member of this family, affording a new link between *Lyginodendrea* (which they resemble in having mesarch xylem-strands) and the true Cordaiteæ.

*Dadoxylon Spencersi* with its dense wood and double leaf-traces appears to stand near the typical Cordaiteæ, and also as Williamson pointed out, suggests the recent *Gingko*, which may itself have Cordaitean affinities. The primary xylem-strands, though much reduced, have essentially the same structure as in *Lyginodendron*. This fossil indicates that in the period of the Upper Carboniferous, stems which had in other respects attained a typically Gymnospermous character, had not quite lost the primitive form of wood, which we can trace back, through the Cycadofilices, to the Ferns.

Permeability of Cell-walls to Air.\*—C. Steinbrinck describes some experiments on the cell-walls of the sporangia of ferns and *Selaginella*, and of the leaves of mosses with reference to their permeability to the passage of air. A historical introduction is followed by a descrip-

\* *Flora*, xcii. (1903) pp. 102-31 (1 pl.).



tion of the different methods of investigation—by means of the air-pump, &c. The results of the experiments are then detailed; the permeability of dry and damp cell-walls under reduced and increased atmospheric pressure. The cell-wall is even more pervious in the damp than in the dry state. The dry moss-cell contains very little air owing to the strong contraction of the walls when dry. It is difficult to explain the rapid extrusion of air and infiltration of water into the active sporangial cells of ferns and *Selaginella*. In the leaves of *Mnium* only a portion of the membrane of each cell is permeable—probably the upper and lower tangential walls; the other parts resist a pressure of several atmospheres.

**Ferns and Fern Allies of North America.\***—W. R. Maxon has compiled a list of the vascular cryptogams of North America north of Mexico, with their principal synonyms and geographical distribution. The list comprises 280 species, 26 varieties, and a hybrid, and is based on an examination of the national herbaria and the principal private collections of the country. An account is given of the only two standard treatises, by D. C. Eaton and L. M. Underwood respectively, which cover the whole of the vast territory under notice; and this is followed by a chronological bibliography of the principal papers and lists that bear upon the subject.

L. M. Underwood † publishes a severe criticism of Hooker's *Synopsis Filicum* with special reference to the genus *Gymnogramme*, which he shows to comprise fragments of several generic groups in no way related to one another save in the absence of an involucre. Some are related to the Polypodiæ, some to the Aspidiæ, one possibly to the Vittariæ, and others to the Asplenieæ. It is as great an error to transfer them bodily to the Pterideæ as is done in *Die natürlichen Pflanzenfamilien*. The name *Gymnogramma* may have to give way to the earlier name *Gymnopteris*. Only two of the species occur in the United States, and they belong to two distinct genera *Ceropteris* and *Bommeria*, and to the former of these is now added another species from California.

The same author ‡ supplies a preliminary review of the genus *Danaea*, with a synopsis of twelve North American species, among which are five new.

**Equisetum hyemale.§**—A. Bennett records and discusses the distribution of *Equisetum hyemale* in Scotland, Scandinavia, and North America.

#### Mosses.

**European Harpidia.||**—C. Warnstorf publishes a detailed study of the difficult section of the genus *Hypnum*, usually known as the Harpidium group. Aquatic in habit, the species are extremely variable and well-nigh impossible to define. After summarising the various schemes of classifying the group which have been put forward by Sanio, Renauld, Klinggræff, and Limpricht, the author gives a list of the collections which he has examined and proceeds to unfold his own views,

\* Proc. U.S. Nat. Museum, xxiii. (1901) pp. 619-51.

† Bull. Torrey Bot. Club, xxix. (1902) pp. 617-34.

‡ Tom. cit., pp. 669-79.

§ Ann. of Scottish Nat. Hist., 1903, pp. 47-8.

|| Beih. z. Bot. Centralbl., xiii. (1903) pp. 288-430 (2 pls.).

beginning with a general discussion of the anatomy of the plants and passing on to the systematic treatment of the group. He discards the name *Harpidium* as being already in use for a genus of Lichens, and accepts *Drepanocladus* C.M. as a better generic name. He then offers a scheme of classification containing several sections and, in all, twenty European species with their synonymies; and, after describing in full some of the less known species with their varieties and forms, he concludes with some critical remarks.

**Streptopogon.\***—E. S. Salmon monographs the genus *Streptopogon*. Twenty-six species had been ascribed to it. Nine of these must be excluded, as the author shows, and the residual seventeen may be referred to five species and one variety. These five species, maintained by the author, are all South American, but two of them are found also in Madagascar. The genus and species are defined at great length and supplied with full synonymy and distribution, and abundant historical and critical observations. A bibliography and three plates with ninety-seven figures are included.

**Calyptopogon.†**—E. S. Salmon discusses the history and synonymy of the Chilean moss, *Calyptopogon mnioides* Broth., which was originally figured and described by Schwaegrichen as *Barbula mnioides*. It was then confused with *B. prostrata* Mont. by C. Müller, and later on was redescribed as a new moss as *B. crispata* by Hampe, and as *B. crispatula* and *B. Wilhelmii* by C. Müller, also as *Streptopogon Hookeri* by R. Brown. Its distribution is now extended to Patagonia and Ecuador, and also to Australia, Tasmania, and New Zealand. The author discusses the value of *Calyptopogon* as a genus, and shows that its systematic position is between *Streptopogon* and *Barbula* (*Syntrichia*); points out that the limb of the leaf is unistratose, despite what Carl Müller has said about it; gives the full synonymy for the species, a lengthy description and the geographical distribution, and describes a new variety from New Zealand.

**Sematophyllum in North America.‡**—E. G. Britton gives a detailed figure of *Sematophyllum recurvans* and discusses its history, affinities, and synonymy. Authors are much at variance as to the latter and as to some allied species owing to the loss of Michaux's types. The degree of variability of the species is not yet settled. The plant occurs in Canada and the eastern and central United States. It is contrasted with *S. delicatulum*.

**Orthotrichum in the United States.§**—A. J. Grout publishes a monograph of the genus *Orthotrichum* and describes ten species that are found in the United States, giving detailed figures of eight of them. He simplifies the differences as much as possible, to enable the student to discriminate the species with a pocket-lens. He calls attention to the continued shrinkage that occurs in herbarium specimens, and insists

\* Ann. of Bot., xviii. (1903) pp. 107-50 (3 pls.).

† Journ. of Bot., xli. (1903) pp. 1-8, 46-51 (1 table).

‡ Bryologist, vi. (1903) pp. 1-3 (1 pl.).

§ Tom. cit., pp. 4-13 (5 pls. and 3 figs. in text).

upon a prolonged and thorough soaking as necessary to restore the primitive dimensions of the plant.

**Microthamnion.\*** — P. Hennings claims that the generic name *Microthamnium* Mitt. should be suppressed on the plea that *Microthamnion* Naeg. was established in 1849, that is 20 years earlier, for a genus of Algæ. Instead, he proposes *Mittenothamnium*. Also he claims that *Asterella* is not available for a genus of hepatics as it was applied to a genus of Fungi by Saccardo 10 years ago.

**Leaf-cells of Sphagnum.†** — W. Lorch describes the comparative development of the stem-leaves and branch-leaves of *Sphagnum*, and the differentiation of the hyaline cells and the chlorophyll-cells. He then passes on to the consideration of the perforations in the stem-leaves of certain Sphagna. He divides the pores in the hyaline cells into two groups according to whether they do or do not retain the original shape in which they were developed. In the branch-leaves the pores entirely retain the original shape; but in the stem-leaves they do not; they assume all shapes, and there is often a complete or partial resorption of the outer wall. Pores are produced during the bud-stage on the under or convex side of the leaf; but they do not appear on the upper or concave side till later—and in some cases not at all. It is essential to employ stains to render the pores visible. Methyl-blue and methyl-violet act well. They stain the under but not the upper membranes. This may be explained in two ways. Either the upper walls are thinner than the lower, and contain less colourable material; or the material of the upper membrane is different from that of the lower, and probably this is the true explanation, because in the young leaf the development of pores takes place on the under side only.

**European Muscineæ.‡** — V. Schiffner gives an annotated list of nine rare hepatics and one moss gathered in new localities in Austria by J. Baumgartner; and a second list of ten rare mosses and two hepatics mostly gathered by the same collector and all from new Austrian localities.

A. Casares Gil§ publishes a list of 25 hepatics and 45 mosses gathered by himself in the neighbourhood of Barcelona, and mentions five other mosses which he has failed to find but had previously been recorded for the district. He adds some remarks upon the dryness of the climate and its effect upon the moss-flora.

**Muscineæ of the Atlantic Islands.||** — V. Schiffner concludes his contributions to our knowledge of the Muscineæ of the Atlantic Islands. He enumerates in all some 40 species of hepatics and 80 species of mosses with numerous varieties. The novelties are three species and one variety among the hepatics, and one species and three varieties among the mosses. Several critical notes are introduced, and the dis-

\* Hedwigia, xli. (1902) Beibl., p. 225.

† Flora, xcii. (1903) pp. 84-97 (10 figs. in text).

‡ Verh. d. k. k. Zool.-bot. Ges., lii. (1902) pp. 703-11.

§ Bol. Soc. Española Hist. Nat., ii. (1902) pp. 327-33.

|| Hedwigia, xli. (1902) pp. 273-94.

tribution of the plants in the islands concerned is rendered much more complete than it has ever been before.

**British Hepaticæ.\***—S. M. Macvicar records the discovery of the rare hepatic, *Geocalyx graveolens* Nees, for the first time in the British Isles, near the sea in West Ross-shire. It grows associated with other Muscineæ on moist rocks, and on it were found the curious pouched perigynia which characterise the genus. A new description of the plant is supplied.

A. Wilson and J. A. Wheldon † have discovered on Cockerham Moss in West Lancashire a hepatic which proves to be *Kantia submersa* Arnell, and was not previously known to occur in the British Isles. It grows on wet sphagnum bogs. The description of it is republished and some critical notes are appended.

S. M. Macvicar ‡ spent five weeks during June 1900 and 1901 in the neighbourhood of Ben Lawers and explored the mountains to determine their hepatic flora. He records his results, a total of some 114 species, and of these no less than seven are additions to the British Flora. The species are mostly of the eastern type, but about a quarter are of the western or Atlantic type. He adds several critical and some general remarks on distribution.

C. Crossland § completes his account of the hepatics found in the neighbourhood of Halifax, and records 69 species, one of which, *Jubula Hutchinsiae*, is an addition to the county of Yorkshire. He also considers the lichens of the district.

**European Hepaticæ.||**—K. Müller publishes a further list of 45 hepatics gathered in Alsace, four of which are new to the district, and the rest noted as from new localities; also 34 species from new localities in the Alps, two being new to Switzerland. A few more species collected by Röhl in the Rhöngebirge, the flora of which needs further attention, and others from Tyrol, &c. are added.

A. Holler ¶ publishes a list of 111 hepatics collected in the district of Schwaben and Neuburg in Bavaria, with notes as to distribution, geological strata, &c. The classification adopted is that of the *Synopsis Hepaticarum*, with an indication of the modern genus to which each plant is referred.

**European Mosses.\*\***—W. Limpricht carries on the work of his father K. G. Limpricht, who died last autumn, and publishes another part of the supplement to his moss-flora, treating of the acrocarpous mosses from *Tortula* to *Bryum*.

J. Röhl †† publishes a list of 57 species of mosses gathered in the vicinity of Herkulesbad in South Hungary, and describes one new species—*Philonotis Schliephackei*—and eight new varieties.

\* Journ. of Bot., xli. (1903) pp. 18-9.

† Tom. cit., pp. 17-8.

‡ Trans. Proc. Bot. Soc. Edinburgh, 1902, pp. 220-32.

§ Halifax Naturalist, vii. (1903) Supplement, pp. 209-16.

|| Beihefte z. Bot. Centralbl., xiii. (1902) pp. 265-71.

¶ Ber. Naturw. Vereins f. Schwaben und Neuburg, 1902, pp. 65-90.

\*\* Rabenhorst's Kryptog.-Flora, IV. iii. Die Laubmoose, Lief. 38, Nachträge, 1903, pp. 705-68.

†† Hedwigia, xli. (1902) Beiblatt, pp. 215-8.

F. Matouschek\* describes a new form of the well-known moss—*Leucodon sciuroides*—which is remarkable for the crisped leaves on some of its secondary branches, apparently not due to injury by insects. The species is not a variable one. This new form—*crispifolius*—grows near Machendorf in the Jeschkengebirge.

**Mosses of Central Switzerland.**†—R. Keller publishes a localised list of 125 mosses gathered by him in October 1891, near Lungern in Canton Unterwalden and identified by P. Culmann. The distribution of the mosses of Central Switzerland is only partly known.

**Swiss Cryptogams.**‡—E. Fischer publishes a series of notices of all the literature that appeared in 1891 and had any bearing on the cryptogamic flora of Switzerland. He groups them under the three heads, Fungi, Algæ, and Mosses, classing the bacteria and lichens under Fungi, and the hepatics under the Mosses. Twenty-one references are cited under Fungi, eleven under Algæ, and ten under Mosses. Lists of new localities compiled from the literature under notice are given under the heads, Fungi and Mosses.

#### Algæ.

**Plankton of the Alt-Ausseer Lake.**§—Carl von Keissler gives a short note on his gatherings in this small Styrian lake. He records nine species, of which three belong to Peridiniaceæ. Samples were taken from the surface and from other depths down to 10 metres, and short analytical tables are given.

**Diatoms of the Black Sea.**||—C. Mereschkowsky publishes some notes on certain diatoms from the Black Sea, and describes three new species and two new varieties. The author regards a knowledge of the endochrome and the elæoplasts of *Navicula scabriuscula* (Cl. et Grove) Mer. as essential, in order to form a correct estimate as to its systematic position. He gives measurements of the frustules and a figure of the endochrome.

A list is given of 456 species and varieties recorded from the Black Sea, and this is said to be not exhaustive. An interesting fact in connection with this list is noted by the author, namely, that about forty of the Black Sea species are common in the North Sea and the Atlantic and Arctic Oceans, but have never been found in the Mediterranean. He explains this by the theory that in the glacial epoch a vast sea connected the Black Sea, the Caspian, and the Aral with the North Sea and the Arctic Ocean; whereas it was not till comparatively recently that communication was established between the Black Sea and the Mediterranean, by way of the Bosphorus. A plate containing thirty-two figures and four figures in the text serve to illustrate the author's observations.

\* Tom. cit., pp. 218-9.

† Ber. d. Schweiz. Bot. Gesell., Heft xii. (1902) pp. 76-83.

‡ Tom. cit., pp. 59-75.

§ Verh. d. k. k. Zool.-bot. Gesell. Wien, lii. (1902) pp. 706-8.

|| Journ. de Bot., xvi. (1902) pp. 319-24, 358-60, 416-30 (2 pls. and 4 figs. in text).

**Hungarian Diatoms: Lake Balaton.\***—J. Pantocsek publishes a monograph comprising 288 species of diatoms from Lake Balaton in Hungary, including one new genus, some 74 new species, and some 60 new varieties. References to literature are given for each species, as well as a diagnosis in Hungarian and in Latin. The paper is illustrated by 17 plates and one text figure. In the introduction is an account of the methods adopted in gathering and examining the diatoms; and a bibliography is provided.

**Pyrenoids and Elæoplasts in Diatoms.†**—C. Mereschkowsky has succeeded in finding pyrenoids in diatoms which partially or entirely emerge from the endochrome, and may even be seen as free colourless bodies on the inner surface of the chromatophores. He also finds elæoplasts which arise inside the endochrome mass, from which they gradually protrude, still surrounded by the endochrome and of a yellow colour. The author believes that it will be possible after further investigations to prove a genetic connection between pyrenoids and elæoplasts. The coloured elæoplasts are divided by the author into (1) sparsioplasts which are variable in number and position, and (2) stablioplasts which are not variable. Stablioplasts are again divided into placoplasts which are in contact with the chromatophores, and libroplastats which lie free along the middle line of the cell. Instances and figures are given.

**Fossil Diatoms in Rome.‡**—Matteo Lanzi has examined diatomaceous earth taken from the Janiculum and finds it contains 68 species of fresh-water diatoms and several varieties. The species are those generally recorded from shallow water.

The same author also enumerates 63 species of fossil diatoms, found in soil which was excavated from below the Via Nazionale, when the foundations of the Banca d'Italia were being constructed. The genus most abundantly represented was *Epithemia*, and after that the commonest forms were *Navicula radiosa*, *N. elliptica*, *Rhoicosphenia curvata*, *Synedra longissima*, and *Pleurosigma attenuatum*. The species are such as live in fresh or brackish water.

**Diatoms of Lake Cotronia.§**—Matteo Lanzi records 36 species of diatoms from this small lake. The most predominant genus was *Cyclotella*, and all the species found were fresh-water forms and principally floating.

**Centronella and Phæodactylon.||**—Knut Bohlin calls attention to *Centronella Reichelti* Voigt and points out that this organism is a near ally of his *Phæodactylon tricorutum*. He therefore proposes that the new genus *Centronella* be suppressed and the Bohlin species be known as *Phæodactylon Reichelti*. He regards the plant as related to the *Diatomaceæ*. Small figures are given of both species.

\* Balaton Tudományos Tanulmányozásának Eredményei, ii. 2 (1902) 144 pp. (17 pls., 378 figs., and 1 fig. in text).

† Flora, xcii. (1903) pp. 77-83 (4 figs. in text).

‡ Atti Accad. Pont. Nuovi Lincei, xlii. (1889); xlvii. (1894).

§ Op. cit., lv. (June 1902).

|| Hedwigia, Beibl., xli. (1902) pp. 209-10.

*Debarya immersa* West.\* — W. West finds that his recently described species *Mougeotia immersa* must be transferred to the genus *Debarya*.

**Conjugatæ.**† — Charles E. Bessey gives a short account of the structure and classification of this group with a revision of the families and a rearrangement of the North American genera. He divides them into three families, Zygnemataceæ, Desmidiaceæ, and Bacillariaceæ, and gives a key to these, and another to the genera of the Zygnemataceæ. The author regards the Conjugatæ as a degeneration from filamentous algæ of a higher type. Diagnoses are given of the genera in Zygnemataceæ.

**Fresh-water Algæ of the Royal Gardens, Kew.**‡ — F. E. Fritsch publishes a note on the periodical development of the algæ in the artificial waters at Kew, and gives two tables illustrating the development which takes place in a tank near the Jodrell Laboratory and in the lake. He also remarks on the occurrence of certain species in the hot-houses, where desmids and other Conjugatæ are rare before April. The hot-house flora is, however, more or less uniform throughout the year, while the outside flora differs largely in summer and winter, attaining its highest development in August and September. Desmids are entirely absent in winter and are not very common in summer.

**Young Plants of Stigeoclonium.**§ — The same author has made a minute study of the young plant of species of *Stigeoclonium*. After giving an account of the results and views of other authors on this subject, he proceeds to describe his own observations, worked out chiefly on three species which are as distinct from each other as possible. These are *S. variabile* Näg., *S. nanum* Kütz., and a new variety, *simplex*, of *S. farctum* Berthold. Under the heading of "The ordinary type of young plant," the author describes the development of a plant from the moment of the zoospore coming to rest. Species which have well-developed hairs in maturity begin to form them very early in their life-history, and the same may be said of the branching. The development of the base varies according to the species, and plants occur in which the young plant is attached by means of a specially modified basal cell aided by rhizoids. These rhizoids may arise from the basal cell or from the cells above it, and may become multicellular and very long. A description is then given of *S. farctum* Berth. var. nov. *simplex*, and comparisons are drawn between it and other epiphytic species of the genus. The author believes that species of *Herpoteiron*, which possess distinctly septate hairs, are merely stages in the life-history of species of *Stigeoclonium*. Finally, certain other forms belonging to *Endoderma* are discussed, which are possibly connected with *Stigeoclonium*.

**New Genus of Valoniaceæ.**|| — F. Heydrich describes and figures a new marine algæ from Kerama, Loochoo Islands, Japan, and he creates

\* Journ. of Bot., xli. (1903) p. 58; and xl. (1902) p. 144.

† Trans. Amer. Micr. Soc., xxiii. (1902) pp. 145-50.

‡ Ann. of Bot., xvii. (1903) pp. 274-8.

§ Beih. z. Bot. Centralbl., xiii. (1903) pp. 368-87 (2 pls.).

|| Flora, xcii. (1903) pp. 97-101 (4 figs.).

for it the new genus *Rudicularia*. It consists of a slightly encrusted unicellular thallus, having a main axis and whorls of branches, both of which are constricted at intervals. Branched rhizoids are given off either in place of or immediately below a whorl. The main axis is about 3-5 cm. high and about  $\frac{3}{4}$  mm. thick. Vegetative reproduction takes place by the formation of a transverse wall across a constriction near the base of a branch. Rhizoids are then given off from the next joint above and an independent plant starts its existence. The author thinks he has also found sporangia containing a single aplanospore. The paper ends with a comparison between *Rudicularia* and neighbouring genera.

**Melobesiæ.\***—F. Heydrich describes three new species and a new form of a previously known species of *Lithophyllum*, and a new species of *Melobesia*. The species had already been quoted in a list by M. Hariot. They are preserved in the Paris Museum d'Histoire Naturelle.

**Characeæ of Mark Brandenburg.†**—L. Holtz publishes a separate monograph of the Characeæ as a contribution to the larger work on the Cryptogamic flora of the province of Mark Brandenburg. To this end he has, *inter alia*, worked through the herbarium of A. Braun which is preserved in the Berlin Museum, and gathered copious materials for his purpose. He divides his subject into two parts; and devotes the first to a general consideration of the group, the development and structure of the plant, the history, classification, and geographical distribution of the group, and so on. This occupies 42 pages. The rest of the book is concerned with the special study of the Characeæ of the province, the characteristics of the district, the sources of information employed, the systematic treatment of the species and forms, a table of the ponds and lakes explored, and the methods of collecting and preserving the specimens. Five genera and twenty-seven species are recognised. Full descriptions, and geographical and critical notes are supplied.

**Fresh-water Algæ of the North of Ireland.‡**—W. and G. S. West publish a list of 614 species and 107 varieties and forms, representing 139 genera, collected in Lough Neagh and in Donegal, Co. Down, and Co. Louth; a few species are also recorded from Co. Wicklow for the sake of convenience or as a confirmation of previous records for that county. About 12 new species are described and about 24 records are new for the British Isles, while many others, though known from other parts of the British Isles, are new records for Ireland. The authors note a remarkable scarcity of the genus *Vaucheria* and of the desmid *Euastrum insigne* Haas. They also remark on the interesting distribution of the three desmids, *Micrasterias furcata* Ag., *Staurastrum Arcticon* Lund., and *Staurastrum longispinum* Arch., which appear to be confined to the western shores of the British Isles, i.e. Connemara

\* Bull. Mus. d'Hist. Nat. Paris, viii. (1902) pp. 473-6.

† 'Kryptogamenflora der Mark Brandenburg. IV. 1. Characeen.' Leipzig 1903, vi. and 136 pp. and 14 pls.

‡ Trans. Roy. Irish Acad., xxxii. (1902) pp. 1-100 (3 pls.).



and Donegal, the lakes of the Snowdon range, and the extreme north-west of Scotland.

A special section of the paper is devoted to the plankton-algæ of Lough Neagh. The authors describe the method of collecting and remark on the presence or absence of certain forms. Many plants which have been exclusively found in the fresh-water plankton-flora of the Continent are here recorded from Lough Neagh. A tabulated list is given of the plankton species found in Lough Neagh in May 1900 and July 1901, together with records from the upper River Bann and from Lough Beg. Three plates containing 98 figures complete this paper.

**Scottish Algæ.\***—E. A. L. Batters' recently published *Catalogue of the British Marine Algæ* is the source from which, in an unsigned note, a list has been drawn up of all those algæ that are recorded as occurring on the coast of Scotland.

**Javan Algæ.†**—R. Gutwiński gives an account of the algæ collected by Raciborski in 1899 in Java. The Desmidiæ gathered in Siteo Tjibenong pr. Bogor are particularly rich in species and forms. In all, 170 species of algæ are enumerated, raising the algal flora of Java to 918 species, and that of the Dutch Indies to 1774 species. To the Javan flora the actual additions are 7 genera, 108 species, 14 varieties, and 2 forms. Five plates with 79 figures are supplied; and 15 new species, 21 new varieties, and several new forms are described.

**Fossil Algæ.‡**—D. White describes two fossil specimens from the Eurypterid beds at Kokomo, Indiana, and makes of them two new species of the genus *Buthotrephis*. They are of marine origin; and from their form they might be sponges or algæ; but are referred to the latter group as they contain no sponge-spicules. It is certain that they closely resemble *Codium tomentosum* in outward appearance.

**Action of Salt Water on certain Fresh-water Algæ.§**—J. Comère has experimented on certain species of *Cedogonium*, *Spirogyra*, *Vaucheria*, and *Cladophora*, with a view to determining what strength of saline solution can be successfully withstood by them under cultivation. The plants are grown in distilled water, to which is added a certain proportion of a nutritive solution. Artificial sea-water is then prepared and added by drops to the above culture-medium. Fertile specimens quickly succumb to these experiments, and it is necessary to work with young sterile and vigorous plants. Certain species of *Cedogonium* and *Cladophora* are able to bear as much as 35 grm. of marine salts to the litre of water, while *Vaucheria sessilis* was seen to grow in water containing 20 grm. of marine salts to the litre. The results varied with the different species of *Spirogyra*. *S. catenaformis* and *S. varians* flourished in a solution containing 18–20 grm. to the litre, while *S. jugalis* and *S. orbicularis* cannot bear more than 15 grm. to the litre. The figures vary according to circumstances, however, and must not be regarded as

\* Ann. Scottish Nat. Hist., 1903, pp. 55–8.

† Bull. Internat. Acad. Sci. Cracovie, 1902, pp. 575–617 (5 double pls.).

‡ Proc. U.S. Nat. Mus., xxiv. (1902) pp. 265–70 (3 pls.).

§ Nuova Notarisa, xiv. (1903) pp. 18–21.

absolute. As a general rule it may be stated that the more robust the structure and the less delicate the chromatophores of a plant, the more successfully does it withstand the intrusion of salt water. The order of resisting power among the genera experimented upon stands thus:—*Cladophora*, *Edogonium*, *Vaucheria*, and species of *Spirogyra* with large chromatophores, and lastly, species of *Spirogyra* with numerous and slender spirals.

Reverse experiments of cultivating marine species in fresh water were successfully carried out, and the author comes to the conclusion that many algæ can, under favourable conditions, develop equally well in fresh or in salt water.

### Fungi.

**Sclerospora.\***—G. B. Traverso has made a critical study of the species constituting the above genus, *S. Kriegeriana*, *S. macrospora*, and *S. graminicola*, all of them parasitic on grasses. He comes to the conclusion that *S. Kriegeriana* is not distinct from *S. macrospora*, the older species, and that there are but the two forms that attack the Gramineæ *S. macrospora* and *S. graminicola*.

**Urophlyctis bohémica.†**—P. Magnus gives a historical and critical account of this fungus. It was found by Passerini on *Trifolium pratense* and named by him *Synchytrium Trifolii*. At a later date Bubak found it on *T. montanum* and named it *Urophlyctis bohémica*. Magnus confirms its classification under *Urophlyctis*, but gives it the first specific name *Trifolii*. It is found all over Europe.

**Research on Amylomyces β.‡**—This fungus, a species of *Mucor*, has been much used in distilleries on account of the large amount of diastase it contains. W. Henneberg has instituted a series of cultures to test its capacity of growth in various media. A long account is given of the different experiments. The chief results arrived at are, that maize mash is a specially favourable matrix for the growth of the fungus; that in potato mash, under a pressure of 3–4 atm., products of an acid nature are developed which interfere with its growth, though the same substance, less highly heated, might be used with advantage; and finally, that the fungus is very susceptible to many bacteria, and therefore bacterial infection is to be guarded against.

**Biology of Piptocephalis.§**—L. Matruchot has attempted to grow the parasite *Piptocephalis* on other fungi than Mucoraceæ. He experimented with a very large and varied number of fungi, and found that *Piptocephalis* could not be cultivated except on some member of the family of Mucoraceæ. He applied this biological test to a doubtful mould, *Cunninghamella africana*, of which the vegetative characters resembled those of Mucoraceæ, but which instead of sporangia produced only conidia. The *Piptocephalis* grew readily and convinced the writer that *Cunninghamella* was a true *Mucor*.

\* Malpighia, xvi. (1902) pp. 280–90.

† Centralbl. Bakt., ix (1902) pp. 895–7.

‡ Zeitschr. f. Spiritusindustrie, 1902, pp. 19–29 (1 pl.). See also Centralbl. Bakt., ix. (1902) pp. 333–8.

§ Comptes Rendus, cxxxv. (1902) pp. 988–91

**Cytology of Yeast.\***—A. Guillermond has published an important work on this subject. He gives a historical account of previous research, and details the methods employed, then follows the account of work done on special forms of the genera *Saccharomyces*, *Schizosaccharomyces*, and *Dematium*. In all yeast-cells he finds a nucleus that divides by direct division. In discussing the genus *Schizosaccharomyces*, he describes the process of copulation of the yeast-cells and their nuclei which precedes spore-formation. After fusion, the nucleus divides and the daughter-nucleus goes back to the cell from which the fusing nucleus had passed over; both nuclei divide equally to form spores. In other yeast-forms copulation has not been found.

**Study of Nuclei in Yeast and Animal Cells.†**—Feinberg has devoted his attention to the form of the nucleus in one-celled organisms with special reference to yeast, the amœbæ of Myxomycetes, fresh-water rhizopods, and sporozoa. With the exception of yeast he finds that there is no nucleolus in any of the nuclei examined, and no nuclear fibrils corresponding to that of plants and animals. As an equivalent they possess a chromatin body which he terms a nuclear point (*Kernpunkt*) and which is surrounded by nuclear sap.

**Yeast.‡**—Albert Hirschbruch discusses the condition of the yeast-cells in old cultures. He finds in many of them that the nucleus has broken down and he describes three stages in this process of degeneration ending in the total disappearance of the nucleus. He has not determined yet at what stage of degeneration the cell loses the power of multiplication, nor to what extent these degenerated cells can be revived.

Fritz Thibaut § contributes a paper on the influence of the alcoholic fermentation products on the yeast-plant and on the process of fermentation.

**Life-history of Yeasts.||**—Emil Chr. Hansen studied this subject first with *Saccharomyces apiculatus*. He found that this yeast was present on fruits all through the ripening season, transported from one to the other by the agency of insects and especially wasps. It was washed off by rain or was conveyed to the ground with falling fruit and wintered in the soil. The wind was a sufficient agent in again transporting it to ripening fruit the following summer. The connection between the soil and the fruit was so close that this particular yeast was never found in soil far removed from fruit-bearing plants. Hansen found for other species of *Saccharomyces* that their life-history was very similar; only, though they were most abundant in gardens, they were also to be found in soils everywhere. The reason of this, Hansen found, was that those other yeasts increase more abundantly in the moisture of the soil and sustain life longer in water. They can thus be more readily transported in a living condition in water than can *S. apiculatus*.

\* 'Recherches cytologiques sur les levures et quelques moisissures à formes levures,' Lyon, 1902, 289 pp. and 12 pls. See also Hedwigia, Beibl., xli. (1902) p. 233.

† Ber. Deutsch. Bot. Ges., xx. (1902) pp. 567-77 (1 pl.).

‡ Centralbl. Bakt., ix. (1902) pp. 737-43 (1 pl.).

§ Tom. cit., pp. 743-6.

|| Op. cit., x. (1903) pp. 1-8.

**Notes on Erysiphaceæ.\***—E. S. Salmon contributes supplementary information on some species of *Uncinula* from Japan. They present some interesting variations of form and habit. He also comments on the spread of the gooseberry mildew, *Spherotheca mors-uvæ*.

**Morphology and Development of the Ascocarp in Monascus.†**—B. T. P. Barker has followed in minute detail the growth of this fungus. He describes the formation of the ascogonium from one of the cells of the hyphæ and its fertilisation by the antheridium. The ascogonium develops as a large central cell and produces a nest of ascogenous hyphæ, the large cell growing round these and affording protection as well as nutrition. Investing hyphæ which eventually form the peridium are produced from the base of the cell. Meanwhile the ascogenous hyphæ increase and push out the large central cell, and in time produce 8-spored asci. The walls of the asci break down and leave a mass of spores loose in the sporangium-like fruit.

From the development, Barker considers *Monascus* as a comparatively simple type of Ascomycetes and not far removed from a common ancestral type. He compares *Monascus* with other Ascomycetes and with the Oomycetes, and is inclined to consider that a close relationship exists between the latter and the simpler forms of Ascomycetes.

**Chætomium Bostrychoides.‡**—G. Masee describes the corkscrew-like appendages of the perithecium, which are hygroscopic and aid in the dispersal of the spores by uncoiling or expanding. The species is new to Britain.

**New Parasitic Fungi.§**—L. Montemartini and R. Farneti have examined a disease of the vine from the Caucasus, which was supposed to be identical with black-rot. The fungus found growing on the grapes could not be identified with that causing black-rot. The authors find that it is a new species and name it *Physalospora Woroninii*. The perithecia develop in the autumn, and are black, somewhat pyriform, about  $\frac{1}{2}$  mm. in height, and almost superficial; the asci are accompanied by paraphyses. The pycnidial form is smaller but has much the same appearance.

G. Pallacci || examined some plants of *Medicago sativa*, the leaves of which were covered with pale spots. He found that this was caused by the perithecia of a pyrenomycete *Pleosphaerulina Briosiana* sp. n. The perithecia are immersed, then erumpent, globose-oblong; the asci are clavate without paraphyses; the spores colourless and muriform.

G. Briosi and R. Farneti ¶ publish a preliminary note on a disease of the mulberry caused by *Fusarium lateritium*, hitherto recognised only as a saprophyte. The fungus attacks the young buds and does very great damage to the trees. The authors describe three new fungi found also growing on the branches attacked by *Fusarium*: namely *Phoma pyriformis*, *Ph. cicatricula*, and *Coniothyrium mororum*. Their connection with the disease was not determined.

\* Bull. Torrey Bot. Club, xxix. (1902) pp. 647-9.

† Ann. Bot., xvii. (1903) pp. 167-233 (2 pls.).

‡ Journ. Quekett Micr. Club, 1902, pp. 355-6.

§ Atti Ist. Bot. Univ. Pavia, vii. (1902) pp. 33-47 (1 pl.).

|| Tom. cit., pp. 49-53 (1 pl.).

¶ Tom. cit., p. 123.

**Distribution of Plant Diseases.\***—P. Hennings learns from various correspondents that the fungus *Sphaerotheca mors-uvæ* is very prevalent in the Government of Moskau, and that in Riga the whole crop has been ruined by it. He warns cultivators against the appearance of the fungus and advises instant burning of any bushes attacked.

G. Linhart † contributes a note on the occurrence of *Glæosporium caulivorum*, which is to be found on red clover in many districts in Germany. He considers that the spores are distributed with the clover seed, and he recommends washing clover seed with copper sulphate. Lucerne is not subject to attack by this fungus.

**Allescherina and Cryptovalsa.‡**—Michele Abbado has published a monograph of these two genera, both of the *Valsa* type and both with polysporous asci. Under *Allescherina*, a genus recently created by Berlese, he places those species that have scattered perithecia, while he includes in *Cryptovalsa* those forms that have the perithecia closely grouped and where the ostioles emerge together from the matrix. This revision has necessitated a considerable rearranging of species. The spores of both genera are coloured and rather large.

**Claviceps purpurea.§**—C. Engelke has made a series of observations on the development of this fungus. He obtained pure cultures from the ejected spores of the perithecia, and he found in the perithecia club-shaped paraphyses. Infection of the rye floret takes place only before fertilisation. The spores alight on the stigma and germinate there, and the mycelium then bores its way down to the ovary. The formation of the sclerotium thus begins at the base. The irritation caused by the presence of the fungus induces the production of honey-dew by the stigma. The fungus itself does not form the honey-dew as has been supposed. The author still continues his cultures and researches on this fungus.

**New Hypomyces.||**—P. Baccarini describes the fungi he found growing on a dead plant of *Areca madagascariensis* in the botanical gardens at Florence. He made careful cultures of the spores and succeeded in tracing the entire life-history of the fungus in question. The asporous stage was a golden-yellow *Hypomyces* which he named *H. aureus*; the conidial stage was a *Verticillium* with simple, elliptical conidia. A resting-stage of the fungus was also formed, a small yellow sclerotium.

Another species of the same fungus was also cultivated, *H. conviva* sp. n., but only the conidial stages were present; these were a form of *Coremium* and of *Mycogone*.

**Study of Related Forms.¶**—H. Klebahn finds that the perfect form of *Phleospora Ulmi* is a species of *Mycosphærella* which he describes as *M. Ulmi*. A similar research as to *Glæosporium nervisequum* which grows on the leaves of *Platanus orientalis* enabled him to connect that fungus with the pyrenomycete *Laestadia Veneta*. In the latter case he

\* Zeitschr. f. Pflanzenkr., xii. (1902) pp. 278-9.

† Tom. cit., pp. 281-2.

‡ Malpighia, xvi. (1902) pp. 291-330.

§ Hedwigia, Beibl., xli. (1902) pp. 221-2.

|| App. al Nuovo Giorn. Bot. Ital., ix. (1902) pp. 483-98.

¶ Zeitschr. f. Pflanzenkr., xii. (1902) pp. 257-8.

was not able to infect leaves directly with the ascospore, but only with the conidial form produced by their artificial culture. He then got a growth of the *Glæosporium* which placed the connection beyond doubt.

**Glæosporium phomoides.\***—F. Guéguen finds that this fungus, which grows on the fruits of the tomato, is a wound-parasite and has been found only on ripe tomatoes. The mycelium produces suckers which penetrate the cells of the host and destroy the nucleus. The cell is then invaded by the hyphæ of the fungus and the whole tissue is gradually destroyed.

**Monilia fructigena.†**—This fungus has been long known in its conidial and sclerotium forms, and recognised as a "brown-rot" disease of fruits. J. B. S. Norton has recently proved its connection with the *Peziza* stage. The apothecia were attached to sclerotia on the buried peaches that were diseased with the fungus, but only from sclerotia that were over one year old. They developed during April, just about the time of the flowering of the peaches and other fruit-trees. The writer cultivated the conidial stage from the ascospores and infected twigs of peach and plum. He also produced the "brown-rot" by inoculating healthy fruits with conidia that he had developed from the ascospores of the *Peziza*, or more directly with the ascospores themselves.

**Sclerotinia Fuckeliana.‡**—A. Lorrain Smith has investigated a disease of gooseberries that affected the stem, destroying the bark and so killing the bush. She found that it was due to the presence of *Botrytis* and sclerotia, and by culture obtained the *Peziza* form from the sclerotium which proved to be identical with *Sclerotinia Fuckeliana*. A comparison with other forms of *Botrytis* was made, and the development of the mycelium contrasted with that of *Monilia*, also a sclerotium-forming fungus.

**Research on Lichens.§**—M. Fünfstück reviews the work that has been done towards completing our knowledge of Lichens. He cites the papers by Baur and others on the sexuality of the fruit, and concludes that though sexuality in a number of forms is almost established, it has not yet been proved. He touches on the influence exerted by the sub-stratum on the development of the lichen, and draws attention to the growth of the algal cells which remain green under a thick, more or less opaque sheath of hyphæ. All these points require further elucidating, and much research work on Lichens, Fünfstück considers, remains to be done.

**Chinese Lichens.||**—A. Jatta gives a list of 200 species and subspecies of Lichens collected by Father Giraldi in the north of China in the province of Shen-si. About fifty of the species are extra-European and nineteen are new to science. Locality and habitat are carefully recorded for each plant and diagnoses given of the new forms.

\* Bull. Soc. Myc. de France, xviii. (1902) pp. 312-27 (2 pls.).

† Trans. Acad. Sci. St. Louis, xii. (1902) pp. 91-7 (4 pls.).

‡ Journal of Botany, xli. (1903) pp. 19-23.

§ Ber. Deutsch. Bot. Ges., xx. (1903) pp. 62-77.

|| Nuov. Giorn. Bot. Ital., ix. (1902) pp. 460-81.

**Lichen-Flora.\***—Carlo Zanfognini concludes his list of Lichens from the district of Emilia. The present contribution includes the families Lecideaceæ, Verrucareaceæ, Caliciae, Graphidaceæ, Collemaceæ, and Micarææ.

**Lichens from Galapagos.†**—The enumeration of the Lichens from Galapagos by W. G. Farlow is based on the collections of Snodgrass and Heller, and of various previous collectors. The specimens belong chiefly to the larger and more striking forms, which are in most cases identical with species found on the Pacific Coast of America from California to Chile.

**Kryptogamen-Flora: Fungi imperfecti.‡**—In part 86 of this Flora Andreas Allescher concludes the "Fungi imperfecti." He deals with the genera *Hyaloceras*, *Torosporium*, and with the genera belonging to the groups of Dietyosporæ and Scolecosporæ. He also gives a first instalment of additions to the genus *Phyllosticta*. Figures illustrating the genera are given in the text. In part 87 *Phyllosticta* is concluded and the species recently added to the genus *Phoma* are described.

**Black-rot of Grapes.§**—G. Delacroix confirms by experimental cultures the existence of a conidial stage in the fungus *Guignardia Bidwelli*, which forms sclerotia and later pycnidia on grapes. The conidial form resembles a *Scolecotrichum*; single conidia are borne at the apex of upright hyphæ.

**Polymorphism of Microfungi.||**—R. Farneta found an *Oidium* parasitic on *Salvia Horminum* which he describes as *Oidium Hormini*. He made a series of cultures, and from the *Oidium* he developed several forms of *Botrytis*, a sclerotium, and microconidial forms of *Macrosporium* and *Alternaria*.

**Septromyces Opizi.¶**—This plant has also been named in its immature form *Botrytis sceptrum*. C. Engelke found it growing on chestnut husks, and on cultivating it under certain conditions it developed *Aspergillus niger*. He verified the result by repeated culture experiments. A rise of temperature invariably secured a growth of *Aspergillus*. The *Septromyces* form was produced with a lower temperature, a deficient supply of nitrogen, and increased humidity.

**Botrytis parasitica.\*\***—This fungus is the cause of a serious disease of tulips and some other bulbous plants, and Ritzema Bos gives an account of his experience of the disease. It attacks the leaves, causing brown spots; it also attacks the young buds, entirely destroying them. In these cases the *Botrytis* form of the disease is specially prominent. When the bulb is attacked sclerotia are developed. The author has not succeeded in obtaining any *Peziza* fruits, though he has induced the

\* Nuov. Giorn. Bot. Ital., ix. (1902) pp. 434-50.

† Proc. Amer. Acad. Arts and Sci., xxxviii. (1902) pp. 83-9.

‡ Rabenhorst's Kryptogamen-Flora, Bd. i. Abth. vii. Lief. 86 (1902) and 87 (1903).

§ Comptes Rendus, cxxxv. (1902) pp. 1372-4.

|| Estratto Atti R. Ist. Bot. Univ. Pavia, vii. (1902) 42 pp., tav. 17-20. See also Hedwigia, Beibl. xli. (1902) p. 232.

¶ Hedwigia, Beibl. xli. (1902) pp. 219-21.

\*\* Centralbl. Bakt., x. (1903) pp. 18-26.

growth of the *Botrytis* from these sclerotia. He discusses the probable causes of infection and dissemination of the disease.

**Ustilago Panici miliacei.**\*—Y. Takahashi describes this fungus which appears on the inflorescence which is changed into a smut pustule. The author concludes from his observations that the fungus is a true *Sorosporium* and should be named *S. Panici miliacei*.

**Uredo bistortarum D.C.†**—P. Magnus discusses the synonymy of this fungus. He finds that it has no connection with *Puccinia bistorte*. It is identical with *Ustilago bistortarum* Körn. and with *Tilletia bullata* described by Fuckel in the *Symbolæ mycologicae*.

**Hyalospora Aspidiotus.‡**—For this fungus, placed first in the form genus *Uredo*, then in *Melampsorella*, P. Magnus creates the new genus *Hyalospora*, on account of the different form of the *Uredo* sorus. The specific name is that originally given by Mougeot and Nestler, viz. *Polypodii dryopteridis*.

**Effect of Mineral Starvation on the Parasitism of Puccinia.§**—Marshall Ward finds that lack of minerals in no way secures immunity from infection, though seedlings deficient in phosphorus or in nitrogen tend to show retardation of infection. He also finds that the uredospores grown on the starved plants of *Bromus* are entirely normal, though smaller in quantity, and can re infect other plants. High cultivation does not increase resistance or confer immunity, as the most vigorous spores were produced on plants reared in a decoction of horse-dung; the highly fed plant yields more food-material for the fungus, but as long as the host is living the fungus finds material for growth development. The paper is well illustrated by figures in the text and by tables of results.

**Cultures of Uredineæ.||**—Fr. Bubák gives the results of his infection experiments on a number of Uredineæ. *Puccinia Balsamitæ*, he finds, belongs to the Brachypuccineæ; *Æcidium Thymi* is a stage of *Puccinia Stipæ*; *Endophyllum Sedi* is an *Æcidium* and is to be included under *Puccinia longissima*; *Æcidium lactucinum* forms its teleutospores on *Carex muricata*. To *Uromyces Scirpi* belong *Æcidia* found on *Glauca maritima*, *Hippuris vulgaris*, *Sium latifolium*, *Pastinaca sativa*, *Berula angustifolia*, and *Daucus carota*. Infection experiments with *Uromyces Poæ* were tried on *Ranunculus repens* and *R. bulbosus*, and spermatogonia were developed freely. Similar infections of *R. nemorosus* and *R. Ficaria* gave no results.

**Germination of Teleutospores.¶**—V. H. Blackman publishes a note on the conditions of teleutospore germination and of sporidia formation in the Uredineæ. Different authors have figured and described the promycelium in some cases as extremely short, while in others it appears to be several times the length of the teleutospore before the sporidia are given off. Blackman finds that the conditions of germination are alone responsible for this variation. If the spores germinate in moist air the

\* Bot. Mag. Tokyo, xvi. (1902) pp. 183-4 (1 pl.).

† Hedwigia, Beibl. xli. (1902) pp. 223-4.

‡ Tom. cit., pp. 224-5.

§ Proc. Roy. Soc., lxxi. (1902) pp. 138-51 (figs. in text).

|| Centralbl. Bakt., ix. (1902) pp. 913-28 (figs. in text).

¶ New Phyt., ii. (1903) pp. 10-4 (6 figs.).



germ-tube is short; if they are placed in water, the promycelium continues to grow until it emerges from the drop of water. Sporidia are never produced except in the air; as they are wind-borne this condition is essential.

**Research on Basidiomycetes.\***—René Maire follows Brefeld in his classification, including the Uredineæ under the Protobasidiomycetes. He gives a historical account of work done on the cytology of the group, and carefully details his methods of fixing, staining, &c. Maire has examined a few Uredineæ and a very large number of Basidiomycetes, and from his extensive study he arrives at a number of general conclusions, taxonomic as well as cytological. The number of chromosomes in the nucleus is invariably two, though in the basidium the first phases of division show a number of protochromosomes which later resolve themselves also into two chromosomes; the basidium in any species can give rise to two generations of spores on the same sterigma. The cytological results have enabled Maire to group a number of families under the Cantharellineæ: these are the Cantharellaceæ, Clavariaceæ, Hydna-ceæ, Phylacteriaceæ, Peniophoraceæ, and Exobasidiaceæ. They have a varying number of sterigmata and in other respects show a lower type of development than other Autobasidiomycetes. Maire also finds a new family Vuilleminiaceæ with one genus and one species, *Vuilleminia comedens*, distinguished by an irregular hymenium. He does not find that sexuality is proved in the Basidiomycetes: his theory is that the fusion of the two nuclei which takes place in the basidium is not a case of fecundation but of "mixie," a term which he uses to distinguish this phenomenon.

**Dry-rot and other Wood-destroying Fungi.†**—In this treatise Robert Hartig gives an account of dry-rot, *Merulius lacrymans*; the extent and nature of the injury caused by it; the development of the fungus in the woodwork of buildings; with advice as to the best means of preventing or getting rid of the pest. *Polyporus vaporarius* is also shortly described. The author considers it much less harmful than *Merulius lacrymans*.

**Spore-formation in Gastromycetes.‡**—L. Petri publishes an account of his research on the development of the basidia and spores of *Hydnangium carneum*. He finds that while the cells of the vegetative hyphæ may have either one or two nuclei, the hyphæ which are more directly connected with the formation of the spores are binucleate. These two nuclei fuse, giving off at the same time granules which move to the tip of the basidium, and which aid in the formation of the sterigmata or of the spore involucre; the fused nucleus then divides simultaneously into four daughter-nuclei which are connected by fibrils, probably of nuclear origin, with the granules. By means of the fibrils part of the chromatic substance of the nuclei of the basidium passes into

\* Bull. Soc. Myc. de France, xviii. (1902) 211 pp. (8 pls.).

† 'Der echte Hausschwamm und andere das Bauholzzerstörende Pilze,' 2. Aufl. bearb. und herausg. von Dr. C. Freiherr von Tubeuf, Berlin (1902). 165 pp. and 33 figs. See also Hedwigia, Beibl. xli. (1902) pp. 233-7.

‡ App. al Nuovo Giorn. Bot. Ital., ix. (1902) pp. 499-514 (1 pl.).

the spore. Petri considers that the definitive nuclei of the mature spore are derived from the division of a pseudonucleus formed from the chromatic granules. The spore figured by the author has three nuclei.

**Adventitious Growths in Fungi.\***—F. Guéguen has studied the various cases among the higher fungi where an additional hymenium has been formed. He concludes that the malformation is caused by some external interference; it may be some foreign body in contact with the pileus during growth that prevents the growth of the external layer, and so induces the formation of a hymenium.

**Italian Agaricaceæ.†**—Matteo Lanzi has published from time to time descriptions of the larger fungi from the neighbourhood of Rome. A number of the parts have come recently to hand, published at intervals from 1888 to 1894. They deal with white, pink, brown, and purple-spored forms. The species are very fully described and a number of coloured plates accompany the text.

**Boletus Briosianum sp. n.‡**—Rodolfo Farneti gives a careful macroscopical and microscopical description of this new hymenomycete found near Padua. He directs special attention to the chlamydo-spores which resemble teleutospores in form. The anatomy of the fungus is worked out in detail and a water-conducting tissue is described—a phenomenon not hitherto noted. This species of *Boletus* comes under the section *subtomentosi*.

**Study of Fungi.§**—M. Barbier publishes some notes on the methods he has found useful in determining fungi. He makes a tracing of the section of any large fungus and colours the different parts. In examining the spores microscopically he advises the student to make them move, as only by so doing can he determine their exact form.

**Value of Spore Characters.||**—Matteo Lanzi concludes from his observation and experience that the colour and form of fungus spores are of great value in the determination of species. Size is of less importance as there may be considerable variation in dimension.

**Poisoning by Fungi.¶**—L. Rolland inquired into a serious case of illness and death caused by eating fungi. A number of species had been cooked and eaten by the victims, and Rolland was able to identify several species of *Amanita* as the origin of the mischief and especially *A. mappa*. Another case of poisoning he also examined and probably been due to a species of *Lactarius*, but the plants could not be accurately determined from the descriptions given.

L. Lutz\*\* gives an account of an exhibition of edible and poisonous species at Aix-en-Uthe, and J. Offner †† explains the system of inspection that prevails at Grenoble, where a large number of fungi are exposed for sale in the market.

\* Bull. Soc. Myc. de France, xviii. (1902) pp. 305-11 (1 pl.).

† Atti Acc. Pontif. Nuov. Lincei, 1888-1894, pp. 87-196 (6 pls.).

‡ Atti Ist. Bot. Univ. Pavia, vii. (1902) pp. 65-82 (3 pls.).

§ Bull. Soc. Myc. de France, xviii. (1902) pp. 413-6.

|| Atti Acc. Pontif. Nuov. Lincei, li. (1898) pp. 4.

¶ Bull. Soc. Myc. de France, xviii. (1902) pp. 417-22.

\*\* Tom. cit., pp. 423-4.

†† Tom. cit., pp. 425-6.

**Cytology and Physiology of Endophytic Mycorrhiza.\***—Shibata has made additions to our knowledge of Mycorrhiza in species of *Podocarpus*, in *Psilotum triquetrum*, and in *Alnus* and *Myrica*. The most interesting observations were those on *Podocarpus*, in which, according to Nobbe and Hiltner, infected plants are able to assimilate free nitrogen. The cells of the root-tubercles soon become filled with masses of mycelium. The cells of the host then begin to react to the presence of the fungus, the cytoplasm increases and the nucleus grows in size and has more stainable contents. It soon begins to divide by a process of simple direct division till as many as eight nuclei may be found in a single cell. While these changes are taking place the fungus mycelium shows signs of disorganisation, and not only do the contents of the hyphæ become lost, but the chitinous walls themselves become almost completely dissolved. This behaviour suggests the secretion of a ferment or ferments by the host-cell, and Shibata has actually demonstrated the presence of a proteolytic ferment in the infected tubercles. Similar cytological observations were made on *Psilotum*, though here the chitinous walls remain behind as an undigested mass.

In *Alnus* also a proteolytic ferment was demonstrated, though the symbiont in this case seems to be a bacterium-like organism. In *Myrica* the fungus of the tubercle is confined to a definite ring consisting of one to three layers of parenchyma. The radiating arrangement of the hyphal branches of the fungus and the club-shaped swellings at their ends point to a relationship to the genus *Actinomyces*. This would appear to be an actual case of vegetable "actinomycosis," a condition hitherto known only in animals.

**Potato Diseases.†**—*Edomyces leproides*, a disease of beetroots, has been found on potatoes causing nodulose, black, scab-like crusts. These nodules are described as containing irregularly shaped cavities which are filled with the dark-coloured resting-spores of the fungus, one of the Ustilagineæ. Figures of this fungus as it occurs on the potato are given. A second disease, bacteriosis, due to *Bacillus solanacearum*, is also described and figured. The leaves and stalks are attacked first; the bacteria gradually descend the stem and pass into the tubers which they destroy.

*Sclerotinia sclerotiorum* attacks the potato stems, forming sclerotia in the tissues and causing the death of the plant. It occurs on many other herbaceous plants.

*Chrysophlyctis endobiotica,‡* a disease new to this country, is described by M. C. Potter. The outward appearance of the tubers attacked is similar to that described under *Edomyces leproides*; but this fungus belongs to the Chytridineæ. The resting-spores are to be found in the periphery of the nodules imbedded in the plant-tissue. Potter traced it through an early plasmodium stage to the final development of the thick-walled spores.

**Fungus Diseases in Italy.§**—Giovanni Briosi publishes an account of the work done in the Laboratory of Cryptogamic Botany in Padua

\* Pringsh. Jahrb., xxxvii. (1902) pp. 643-84 (2 pls.).

† Journ. Board of Agric., pp. 307-11 (3 pls.).

‡ Tom. cit., pp. 320-3 (1 pl.).

§ Atti Ist. Bot. Univ. Pavia, vii. (1902) pp. 295-356.

on plant diseases in 1900 and 1901. He tabulates the diseases examined under the groups of plants attacked, beginning with the vine, then the cereals, fruit-bearing trees, &c. He also gives separate lists of those observed in the earlier part of the year, and those that were found in the later months. He recapitulates the work that has been done in the laboratory since its foundation in 1871, and gives a list of the papers that have been published by himself or his assistants—a very large proportion of them dealing with fungal diseases of plants. The insect pests are also noted, and suggestions for the cure of many of the maladies are given.

**Fungi of Mount Ventoux.\***—J. Lagarde publishes a first list of fungi from this mountain which forms a continuation of the Southern Alps on the western side. The list is a long one and includes members of all the different groups. In each case the habitat of the fungus is given and the name of the month in which it was gathered.

**Fungi of Lomellina.†**—Angelo Magnaghi publishes a first list of fungi from this district of Lombardy. He records 140 species belonging to the various natural orders. There is one new species, *Phoma Capsici*, parasitic on the fruits of *Capsicum annuum*.

**Fungus Flora.‡**—The same author publishes an account of the fungi collected in Egypt by G. Schweinfurth. The larger forms are fairly well represented, and he describes one new genus, *Battareopsis*, something like *Battarea*, but differing in the form of the gleba. Hennings places it near *Secotium*. The new plant is illustrated by figures in the text. He records several new species of Uredineæ and a new *Hypomyces*.

**African Fungi.§**—P. Hennings finds among these a considerable number of new species, all of them microscopic. There are a number of Uredineæ and other leaf-inhabiting forms. He records two new genera, *Baumiella* a pyrenomycete, and *Hypthastis* a hyphomycete, both with one species.

**Fungus Flora of Sao Paulo.||**—P. Hennings gives a second contribution from the collection of Pultemans. With the exception of three species belonging to *Polyporus*, *Lepista*, and *Scleroderma*, they are all microscopic. There are a few forms of Ustilagineæ and Uredineæ, but by far the largest number, including many new species, belong to the Ascomycetes and the "Fungi imperfecti." He records two new genera, *Capnodiopsis*, closely allied to *Capnodium*, but with a very sparse mycelium, and *Pseudobeltrania*, a member of the Dematiæ group. The latter genus has upright, branched, brown conidiophores bearing acrogenous, septate, brown spores. Both fungi were found on leaves.

**Fungi from Galapagos.¶**—W. G. Farlow in his flora of these islands includes three species of fungi, *Favolus ciliaris*, *Fomes lucidus*, and *Schizophyllum abneum*. There were a few others that were not in a condition to be determined.

\* Bull. Soc. Myc. de France, xviii. (1902) pp. 328-80.

† Atti Ist. Bot. Univ. Pavia, vii. (1902) pp. 105-22.

‡ Hedwigia, Beibl. xli. (1902) pp. 210-5 (2 figs. in text).

§ Fungi: Kunene-Sambesi Expedition, Berlin, 1902, pp. 155-69. See also Hedwigia, Beibl. xli. (1902) pp. 237-8. || Hedwigia, xli. (1902) pp. 295-311.

¶ Proc. Amer. Acad. Arts and Sci., xxxviii. (1902) pp. 82-3.

**Extra-European Fungi.\***—N. Patouillard describes twelve new species of fungi belonging to Basidiomycetes and Pyrenomycetes, and collected both in the Eastern and Western hemispheres.

**Il Trattato dei Funghi.†**—This treatise on Fungi was published anonymously in Rome in 1792, and the authorship has always remained a mystery. Matteo Lanzi has recently taken the matter up and has proved indubitably that it was written by the Baron Girolamo Gavotti.

### Schizophyta.

#### Schizomycetes.

**Genus Crenothrix.‡**—D. D. Jackson gives a general account of this genus which is of importance in connection with water supplies. Hitherto only one species of the genus has been described, *C. kühniana*, the well-known species which precipitates hydroxide of iron and occurs in reddish-brown flocks or strings. A second species, hitherto known as *Leptothrix ochracea*, must be included in this genus; its precipitate is yellowish in colour and consists chiefly of alumina. A third species, which has never been named, is rarer than the second; it precipitates manganese, and as large quantities of manganese are rarely found in water supplies it has had less opportunity than the other species of developing in noticeable amounts; the colour of the precipitate is from brown to almost black. The author calls it *C. manganifera*.

All three species occur chiefly in ground waters, and only grow with rapidity when the dissolved oxygen is lacking, or nearly so, and when the special salts are present which they precipitate. Presence of much organic matter seems to favour growth. The author gives a brief description of the genus and a tabular comparison of the three species, and of the analyses of their precipitates, and of the water in which they grow.

**Streptothrix.§**—A. G. R. Foulerton and C. P. Jones have examined twenty-five species of this fungus, adopting the term *Streptothrix* in preference to the older *Actinomyces*. The mature fungus presents a tangled mycelium, and if growing on the surface of the medium, lateral branches become erect and undergo a process of chain sporulation. Certain lengths of the mycelium then degenerate, and coincident with this change, sporulation in the terminal parts of the mycelium and branches occurs. The free spores have been described as coccid forms of a pleomorphic schizomycete, but the botanical position of *Streptothrix* has been the subject of considerable dispute. Harz regarded it as a hyphomycete, others as a highly pleomorphic schizomycete; but Foulerton and Jones have conclusively shown that the different "forms" of *Streptothrix* are merely different stages in its life-history, and that the fungus is undoubtedly a hyphomycete.

The thermal death-point was ascertained for all the species examined except one, the temperatures varying from 45° C. to 70° C. A considerable portion of the research was concerned with the pathogenic action of the fungus.

\* Bull. Soc. Myc. de France, xviii. (1902) pp. 299-303.

† Atti Acc. Pontif. Nuov. Lineci, li. (1898) pp. 2.

‡ Trans. Amer. Micr. Soc., xxiii. (1902) pp. 31-8 (1 pl.).

§ Trans. Path. Soc. Lond., liii. (1902) pp. 56-127.

E. Levy\* publishes an account of the growth and resting condition of the Streptotrichaceæ. He reviews the work that has been done on these organisms, and compares them with the allied groups of bacteria such as tubercle, diphtheria, &c., which form spores similar to *Streptothrix*.

**Micro-organisms of Barley and Malt.**†—These were investigated by Chrzaszcz in relation to the question of the effect of infection on the germinating power of the grain and on the coloration of both the grain and the malt. Bacteria, yeasts, moulds, and infusoria were all to be observed under the scales of the grain in very varying numbers, sometimes as many as 19 different species being found in one grain. As was to be expected, the strongest germinating power was to be found in grains which were least infected, though in some cases grains which showed only very slight infection refused to germinate. The dark colour of the grains was in some cases found to be due to colouring matters laid down in the wall; while in other cases the darkly coloured grains showed a strong infection with moulds and other organisms. In opposition to former workers who connect the dark coloration of the grains chiefly with *Sphaerella Tulasnei*, the author finds that in the dark grains infected with moulds, *Septosporium* and *Alternaria* were most commonly present.

**Coccus lactis viscosi and the Causes of Sliminess and Threads in Milk.**‡—Th. Gruber describes fully with two microphotographs a new micro-organism which causes milk to become slimy and so that it is capable of being drawn out into threads. To it he gives the name of *Coccus lactis viscosi*. Its chief characters are that it very quickly produces in milk the condition described above, the milk becoming at first alkaline and later acid in reaction. It very quickly produces a liquefaction of 15 p.c. gelatin, and gelatin plate colonies have a characteristic appearance; its growth is better when air is excluded, and the coccus on division has a distinct tendency to divide in two directions at right angles to one another.

**Penetration of Plants by Bacteria.**§—Gustav Ellrodt has re-investigated the question as to whether bacteria are able to penetrate the tissues of unwounded plants. Various plants were grown in soil which was watered with a decoction of *Bact. pyocyaneum*, or else the plants were grown in a nutritive solution to which the same bacterium was added. After various intervals portions of the leaves and stems were removed and examined bacteriologically. Only in those cases in which the plant was wounded were the bacteria found to have penetrated the tissues. The particular bacterium mentioned was selected owing to the fact that it is easily recognisable by its colouring matter.

**Destruction of Non-nitrogenous Organic Substances by Bacteria.**||—O. Emmerling has compiled a summary, which is not exhaustive, of recent work on fermentations. These are arranged under six headings:—

\* Centralbl. Bakt., xxxiii. (1902) pp. 18-23.

† Wochenschr. f. Brauerei, xix. (1902) pp. 590-3. See also Centralbl. Bakt., ix. (1902) pp. 768-71.

‡ Centralbl. Bakt., 2<sup>e</sup> Abt., ix. (1902) pp. 784-92 (1 pl.).

§ Tom. cit., ix. (1902) pp. 639-42.

|| Dr. O. Emmerling, 'Die Zersetzung stickstoffreier organischen Substanzen durch Bakterien,' Braunschweig (Friedrich Vieweg u. Sohn), 1902, 151 pp. and 7 photo. pls. See also Nature, lxxvii. (1903) p. 316.

(1) fermentations accompanied by oxidation; (2) lactic acid fermentations; (3) fermentations yielding mucilage; (4) butyric acid fermentations; (5) fermentation of cellulose; (6) partly unexplained fermentations. The fermented substances considered are carbohydrates. Each section comprises an enumeration of the more important organisms, with a short account of their characteristics, and the subsidiary products of the fermentations. The economic aspect of lactic fermentations is considered in brief. While mainly intended for chemists, the book is also adapted for those interested in the subject from a physiological standpoint.

**Root-tubercles of *Medicago denticulata* and other Leguminous Plants.\***—G. J. Peirce has examined the origin, morphology, and structure of root-tubercles, especially on the Bur Clover (*Medicago denticulata*). He finds that the tubercle bacteria enter a root-hair by softening or dissolving a small portion of the wall. There is no evidence that they usually enter through broken root-hairs. The proportion of root-hairs infected to the number formed is small; in one case computed to be 1 in 1000. The infection thread grows fairly straight through the cortical parenchyma to the layer of cells next outside the central cylinder of the root. The tubercles arise endogenously from the same layer as the lateral roots. We may therefore conclude that they are morphologically lateral roots; they are formed only as the result of stimulation by bacteria. The author asks whether lateral roots arise as the result of internal causes or external stimuli. The growth of the tubercle is apical, the daughter-cells of a bowl-shaped terminal meristem constituting the growing part of the tubercle. There is little or no secondary growth in thickness. Tubercles are largest and most numerous near the surface of the soil. It is possible that perennial Leguminosæ form few if any tubercles after their roots have grown deep into the soil.

The presence of bacteria in the cells of a tubercle prevents the infected cells from forming starch. Uninfected cells do not attain the size usually reached by infected cells: the larger size of infected cells is due to increased pressure, probably also to greater irritation. The bacteria cause the degeneration and almost complete destruction of the nuclei of the cells in which they occur. The infection strands grow definitely, chemotropically, toward the daughter-cells formed by the tubercle meristem, and seem also to grow definitely toward the nuclei of the cells into which they penetrate. Infected cells soon lose power of division, though not of growth. The relation of the bacteria to their host-cells is parasitism, and it is difficult to understand how the leguminous plant as a whole can profit by an association which is injurious and finally destructive to the cells in which the bacteria occur. Intercellular spaces occur in the tissues of root-tubercles; and even if they did not it would not be necessary to assume that the bacteria live anaerobically therein, since the tubercle-cells do not live anaerobically.

**Intracellular Toxin of the Typhoid Bacillus.†**—A. Macfadyen and S. Rowland conclude that the typhoid bacillus contains within itself an

\* Proc. Calif. Acad. Sci., ser. 3 (Botany) ii. (1902) pp. 295-328 (1 pl.).

† Proc. Roy. Soc., lxxi. (1902) pp. 77-8.

intracellular toxin. Organisms grown on ordinary beef-broth agar were, after washing, disintegrated in a mechanical contrivance at  $-180^{\circ}$  C. When the disintegrated mass is freed from whole bacilli (if present) and from other suspended insoluble particles by centrifugalisation, an opalescent fluid remains which on inoculation into animals in small doses invariably proves toxic or fatal. The authors had previously shown that the filtrates from cultures of bacillus on the actual intracellular juices of organs and tissues obtained in a fresh condition from the ox or calf, did not exhibit toxic power. Hence they conclude that the poison is intracellular and not extracellular.

**Antibodies of Spores of Bacteria.\***—W. Defalle finds that the injection of the spores of bacteria into the animal body results in the formation of an antibody in the serum of the animal. It was shown that the formation of this antibody was entirely due to the absorption of the spores as such, and not as the result of their germination.

**Leprosy. Bacillus.†**—The research of W. W. Iwanhow, who experimented chiefly upon dogs and guinea-pigs, shows that, in spite of the rapid phagocytosis of leprosy bacilli injected into the peritoneal cavity, the bacilli are very numerous, and for the most part quite unaltered eight months after injection. At the end of one month, the bacilli are also found to occur with more or less regularity in the internal organs, e. g. liver, spleen, kidneys, &c.

**Putrefaction of Meat.‡**—After a brief historical survey of the question, Tissier and Martelly give an account, in considerable detail, of the methods employed by them in their research.

Thirteen species of bacteria were isolated, and a description of each, with an account of its action upon the constituents of meat, is given. Of the thirteen species isolated, five are new. The organisms group themselves naturally into two classes, viz. those attacking both the carbohydrates and proteids of the meat, and those attacking the proteids alone. Organisms of the former class bring about the first stage in the putrefactive processes, the sugar, as such, being destroyed, and the attack upon the proteids begun. This stage is followed by that in which the action upon the albumin and its derivatives is completed by the purely proteolytic bacteria of the latter class. The authors find that the species most potent in bringing about the putrefactive changes are *Bacillus putrificus coli*, *Micrococcus flavus liquefaciens*, and *Bacillus bifementans sporogenes*, the latter being one of the new species.

**Bacteriology.§**—The section Bacteriology (R) of the International Catalogue of Scientific Literature appeared early in the year. Dr. J. W. H. Eyre is the referee for the volume, which contains 314 pages. The first part consists of an authors catalogue, the second of a subject catalogue. The subject-matter is subdivided as follows:—(1) General, including Philosophy, History, Periodicals, Reports, Bibliography, Text-books,

\* Ann. Inst. Pasteur, xvi. (1902) pp. 756-74.

† Tom. cit. pp. 705-83 (2 pls.).

‡ Tom. cit., pp. 865-903.

§ § International Catalogue of Scientific Literature. First Annual Issue. R. Bacteriology. Royal Society of London, December 1902.



Nomenclature, &c. (2) Methods and Apparatus. (3) General Bacteriology with the subdivisions Morphology, Classification, and Physiology. (4) Special Bacteriology with subdivisions Bacteria, &c. in relation to non-living surroundings, and Bacteria in relation to higher organisms. The latter are considered as (a) Bacteria not known to be pathogenic, (b) Pathogenic Bacteria; the second heading comprises the sections Immunity; Infectious diseases: General; Infectious diseases: Local; Diseases in different classes of animals; Diseases in plants due to micro-organisms.

At the end of the volume is a key to the abbreviated titles of the journals, and at the beginning the schedules and indexes are given in English, French, German, and Italian.

**Bacteria in Daily Life.\***—Mrs. Percy Frankland's book puts in a handy and readable form an account of the part played by bacteria in the economy of daily life. The treatment is popular but scientific, technical terms are avoided, and it is a book which should help much towards the removal of that indifference to and ignorance of the importance of "germs" which is so characteristic of the ordinary person. The first chapter, 'Bacteriology in the Victorian Era,' gives an excellent résumé of the birth and subsequent progress of this branch of biology. Starting with the announcement by Cagniard Latour in 1837, that the spherules of beer-yeast were a living, not a dead chemical substance, the author indicates the chief directions in which advance has since been made, and mentions a few of the many names—Pasteur, Robert Koch, Lister, and others, who have been associated with the progress of the science. 'What we breathe,' the title of the second chapter, emphasises the importance of fresh air and ventilation, and describes how germs of tuberculosis and other diseases are distributed with the dust. The next, 'Sunshine and Life,' is an interesting résumé of a great deal of work which goes to show the efficacy of bright sunshine as a germ-destroyer, and also as a modifying agent of the activity of the organism. The text for 'Bacteriology and Water' is found in the outbreak of cholera at Hamburg and Altona in 1892, and shows very clearly the relation which obtains between a pure water-supply and a low death-rate, and at the same time, the value of the sand filter-bed. 'Milk Dangers and Remedies' gives a vivid account of the backwardness of our own folks as compared with Americans and Continental nations. "So strong is the prejudice amongst our neighbours across the Channel against using unboiled milk, that in Leipzig and other cities in Germany endeavours have been made by charitable and other societies to encourage the use of sterile milk amongst the poorer classes, while it has been stated that the introduction of Pasteurised milk among the poor of New York city has done much to reduce the high rate of mortality amongst infants during the hot summer months." The relation of bacteria to extreme cold and the remarkable powers of resistance possessed by some of them is described in the chapter, 'Bacteria and Ice.' The last chapter, 'Poisons and their prevention,' deals with the interesting and important subject of toxins and antitoxins.

\* 'Bacteria in Daily Life,' Longmans, 1903, 8vo, 216 pp.

MICROSCOPY.

A. Instruments, Accessories, &c.\*

(1) Stands.

New Arrangement for avoiding Injury to Preparations when Focussing with High Powers.† — A. Bourguet's contrivance for this

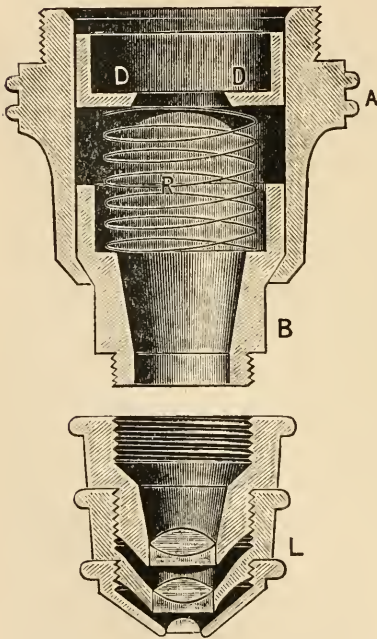

FIG. 37.

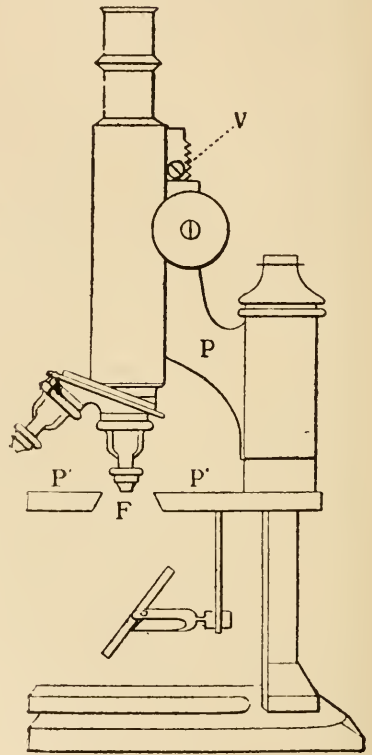

FIG. 38.

purpose consists of a special tube-funnel and a stop for limiting the descent of the Microscope-tube. The funnel (*entonnoir*) is that upper part of the objective-mount which does not contain a lens, and is here

\* This subdivision contains (1) Stands; (2) Eye-pieces and Objectives; (3) Illuminating and other Apparatus; (4) Photomicrography; (5) Microscopical Optics and Manipulation; (6) Miscellaneous.

† Zeitschr. f. wiss. Mikr., xix. (1902) pp. 35-40 (2 figs.).

made of a special shape, being composed of two separate pieces, A and B (fig. 37), one within the other, instead of one single piece. The upper piece A bears above, as usual, the universal screw-thread for securing the objective to the revolver or Microscope-tube; below it tapers, conewise, for receiving or retaining in its lower part the other piece B. The latter is formed of two cylindrical parts of unequal diameter fitting exactly into the conical part of A; it bears on its lower part a screw-thread, on to which the objective system L is to be screwed. A very weak spiral spring R operates between the lower face of the diaphragm D and the upper part of the shoulder of B. The pressure of the spring keeps B and A in close contact by their conical shoulders. B projects 5 mm. (exclusive of the threaded part) below A. In order to facilitate the screwing-on of L and prevent useless rotation of B, a vertical groove is cut in either A or B, in which a pin secured to the other engages. If, in the action of focussing, the tube is lowered too far the preparation will bear only the weight of the objective and will, by the operation of the spring, be relieved from further pressure. The stop system, which is shown in fig. 38, secures that the tube shall not be lowered beyond a certain safe limit, which should be selected with regard to the highest power of the operator's series. This stop is merely a screw V applied to the side of the rackwork, and its head comes into contact with the upper part of the limb when the tube is at the assigned depth. To exactly determine the position of V the micrometer-screw is fully racked down. Then the strongest objective, previously provided with a sliding funnel of 5 mm. range, is screwed on and the tube is then racked up until the lower extremity F' of the objective is exactly on a level with the upper surface of the stage P' P'. The point where the rackwork emerges from the limb is V.

**Modern Fine Adjustments.\***—W. Forgan lays down the various qualities essential to a good fine adjustment and discusses some thirty-four different types. Some of these types are of historical interest only; others exemplify the different constructions adopted by the best-known modern makers of all countries. He concludes by summarising the types before the public as three:—(1) The Powell and Lealand; (2) the Zeiss; and (3) the Watson Edinburgh Student's Microscope.

#### (2) Eye-pieces and Objectives.

**Eye-piece Lens Interval as arranged for Achromatism.†**—J. Hunter illustrates his remarks on this subject by reference to fig. 39, which is the double-lens achromatic eye-piece of a telescope. The lenses are plano-convex. The points A B are the optic centres; C D the planes of the flat sides; O X the posterior focal centre (cardinal points) of the field and eye-lens respectively; the anterior focal centres coincide, in this kind of combination, with the optic centres. The author points out that various writers of high mathematical repute have variously estimated the separation interval as D C, A C, or A B; X O does not appear to have been selected by any writer. He himself prefers A O.

\* Proc. Scottish Micr. Soc., iii. (1902) pp. 137-57.

† Tom. cit., pp. 294-9 (1 fig.).

He found that when a pair of lenses of the same glass were placed experimentally at such a distance apart as to give the best achromatic

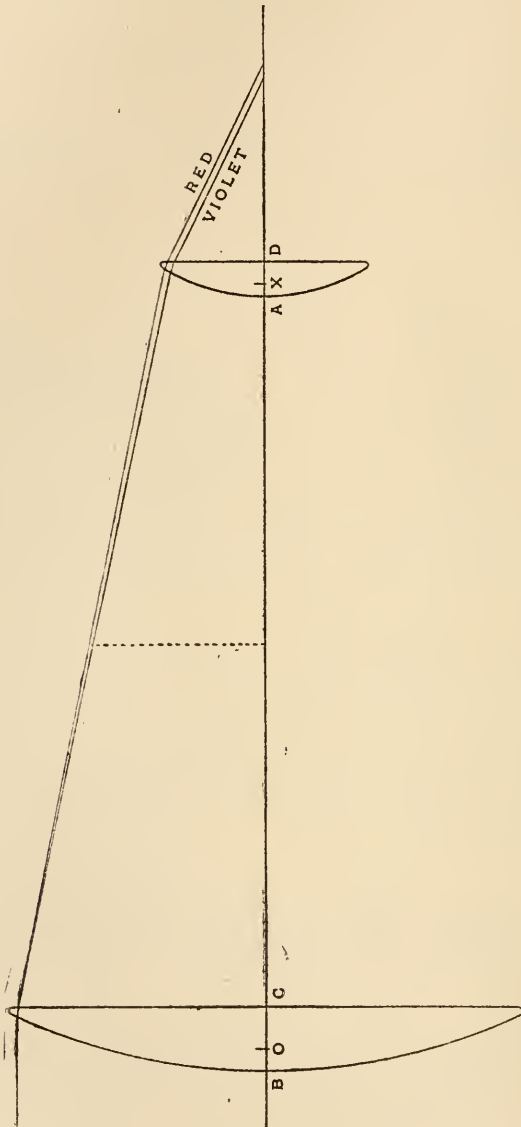

Twice original scale.

FIG. 39.

image, that the value of  $A O$ , so obtained, agreed with the value of  $d$  calculated from Airy's more complete formula for achromatism, viz. :—

$$d = (f_1 + f_2) \left( 2 - \frac{f_1}{u} \right)^{-1};$$

where  $d$  = distance between the lenses ;  $f_1, f_2$ , the focal distances of field and eye-lenses respectively ;  $u$ , the distance between the field-lens and the centre of the objective.

(4) Photomicrography.

**New Device for Stereoscopic Photomicrography.\***—F. E. Ives has recently made a one-plate-one-exposure stereoscopic photomicrographic

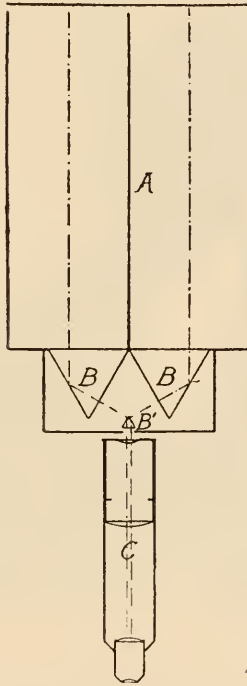

FIG. 40.

camera which is interchangeable with his single camera on the adjustable base.† It consists of a light telescopic box camera for plates  $3\frac{1}{3}$  by 6 in., provided at the front with a small prism-box containing three equilateral prisms so disposed as to divide the light at the eye-point above the eye-piece of the Microscope, and project the divided rays upwards to form the two stereoscopic images. Fig. 40 shows the parts drawn to scale.

\* Journ. Franklin Institute, cliv. (1902) pp. 391-3 (2 figs).  
 † Op. cit., cliii. (1902) p. 375; and this Journal, 1902, p. 491.

A is the camera, B B' are the prisms, C is the Microscope-tube with objective and low-power eye-piece, D is the object-slide, and the dotted lines show the path of the axial rays from the back of the objective. The author considers that it is much better to divide the light, in this manner, at the eye-point than to divide it, as is generally done, at the back of the objective. If a lens of the focal length of the camera be added as a cap for the eye-piece, the camera can be used without even refocussing, in the fashion of the author's previous instrument. The prism-box has a lateral fine adjustment by screw on the camera front,

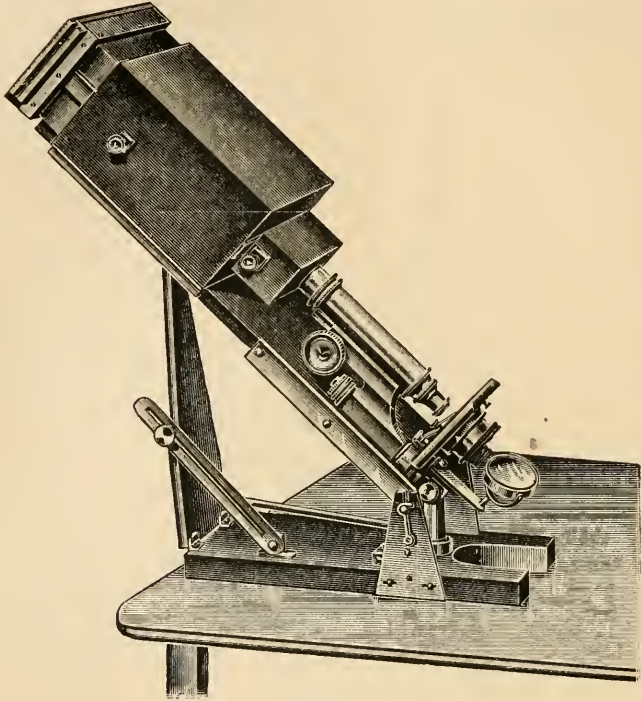

FIG. 41.

in order to readily set it, so that the apex of the small prism should exactly bisect the circle of light at the eye-piece. The negatives produced in this camera are ready for printing from, no transposition of images being necessary. Fig. 41 shows the stereoscopic camera used on the adjustable base, as recently improved. The combination can be adapted to the Microscope at any inclination and brought into action in a few seconds; and, after exposing, it is removed as a rigid whole by a single rectilinear movement of one hand.

**New Upright Photomicrographic Apparatus.\***—In designing his apparatus J. A. Terras has studied the convenience of the operator. As

\* Proc. Scottish Micr. Soc., iii. (1902) pp. 210-2.

will be seen from fig. 42, the arrangement practically comprises a Van Heurck camera, in which the solid body has been replaced by a conical bellows, and the limbs elongated sufficiently to make the instrument completely independent of other supports; while the Microscope-table has become an integral part of the camera, and is lowered to such an

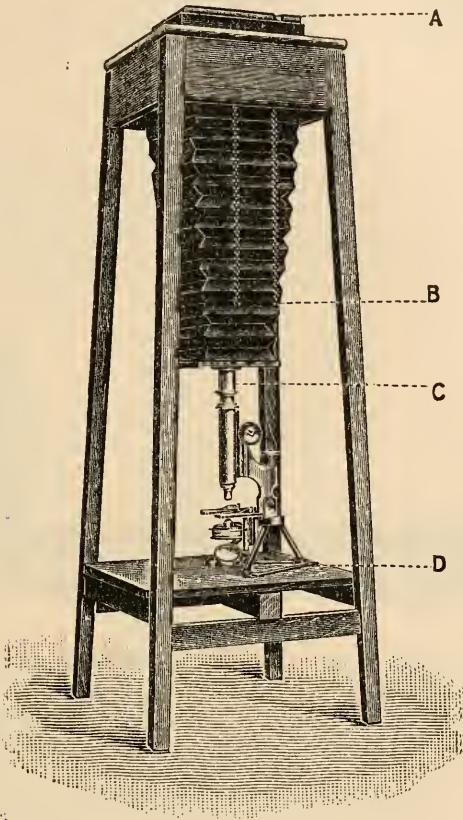

FIG. 42.

extent as to allow the operator to stand comfortably on the floor. This camera-stand is placed on the floor, close to the laboratory table. An approximately parallel beam of light is thrown across the lower shelf of the instrument from an ordinary optical lantern occupying a low independent stand, and from which the projection front has been removed. The most satisfactory light-source was found to be the oxy-hydrogen jet, but an incandescent gas-burner is good for at least the lower powers. The total height to the focussing screen is 46 in. but could be varied to suit different observers. From the eye-piece to the sensitive plate is 24 in. The top is a square of 12 in. side with a centre fitting for a

April 15th, 1903

q

half-plate dark slide A. B is a pair of light brass chains which engage with hooks on the opposite side of the frame, and by which the camera-bellows may be supported when not in use. C is the brass union between the eye-piece and the bellows; D, two guides into which the base of the Microscope fits.

HERSCHEL, SIR W. J.—Colour Photography.

[Gives a sketch of Ives' and Sanger Shepherd's methods.]

*Brit. Journ. of Photog.*, July 12, 1901, pp. 439-41 (3 coloured pls.);  
*Ann. Rep. Smithsonian Institute*, 1901, pp. 313-6.

(5) Microscopical Optics and Manipulation.

Leiss' New Crystal Refractometer for the Determination of the Refractive Index of Large and Microscopically Small Objects.\*—This instrument, designed by C. Leiss, is intended to apply to small crystals, as well as to mineral plates enclosed in thin sections. It may be considered as an improvement of the refractometer of C. Klein.† Two essentials of construction are:—(1) The association of the instrument

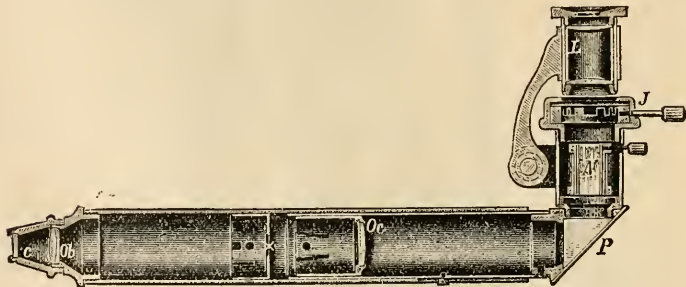

FIG. 43.

with a Microscope; (2) the stopping-out of all disturbing light. The Microscope (or telescope) is shown in fig. 43; for convenience of observation it is made with an elbow. *Ob* is the objective whose focal plane is marked X; *Oc* is the single-lens ocular; P, the totally reflecting prism; N, a nicol which can be inserted at pleasure and can be rotated by a small knob; J is the iris diaphragm placed at the Ramsden circle of the ocular; L is an observation lens, as recommended by Czapski and Pulfrich, formed of two lenses, adjustable in a sleeve and, by means of a hinged arm, quickly applied to the iris or removed. The lens *c* in front of objective *Ob* is the well-known correction lens, which parallelises the beams emergent from the hemisphere. The application of the loup L makes the telescope into a Microscope of small magnification, and with it the preparation can be viewed not only from above (through the air) but also from below (through the hemisphere). A proper selection of lenses enables this to be done without special correction or change in the adjustment of the Microscope. When the loup L is removed, the telescope gives a magnification of  $1\frac{1}{4}$ ; when the loup is applied the

\* *Zeitschr. f. Instrumentenk.*, xxii. (1902) pp. 331-4 (3 figs.).

† *S.B. Berl. Akad.*, 1902, pp. 113 and 653.



*Microscope* magnifies 10 diameters. The *Microscope* having been arranged, the preparation is moistened with some strongly refracting liquid and hand-centred; the iris rotated to cut off all superfluous light so that only the preparation to be measured is visible through the *Microscope*. Whether the object is viewed from above or below it is well to illuminate it with the usual mirror. When the loup is removed the limiting angle is viewed with the telescope.

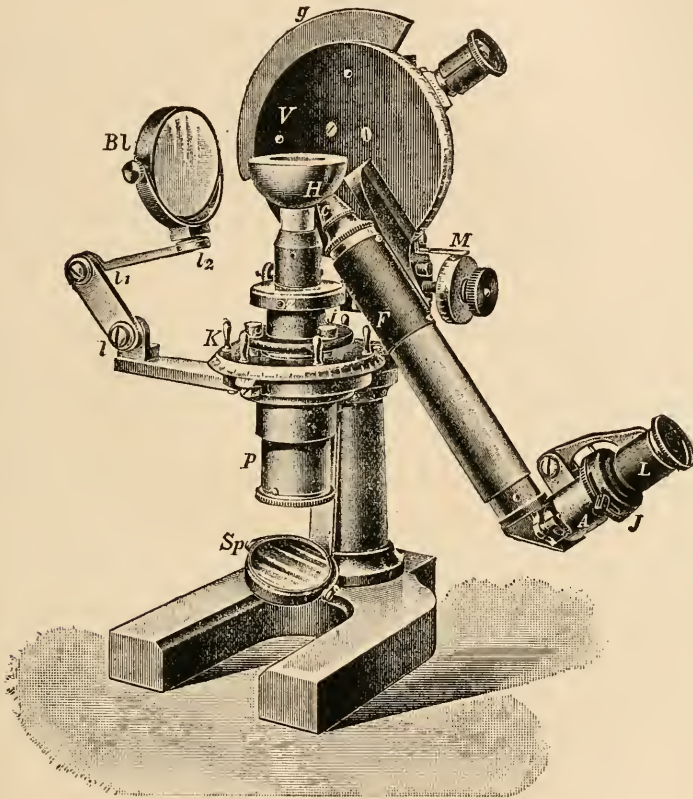

FIG. 44.

The general appearance of the instrument is shown in fig. 44. In the stage-plate, carried on a pillar set on the horseshoe foot, is a rotatory horizontal circle graduated in degrees. Above, it bears a perforated prolongation on which the hemisphere H is situated. The screws *z* and *j* respectively centre and adjust the hemisphere. *Sp* is the mirror for the under illumination. In the tube P, just above the mirror, is the nicol polariser adjustable, by means of its sleeve, in the three positions of  $0^\circ$ ,  $45^\circ$ ,  $90^\circ$ . The vertical circle V, on which the telescope (or *Microscope*) is affixed, is graduated into half degrees, and by means of

a vernier lens can be read to minutes. The graduation of the circle is from  $0^\circ$  to  $100^\circ$ ; but there is a mark on the circle which must coincide with the vernier-zero when the Microscope is to be vertical. The micrometer-screw M has a pitch of 0.5 mm.; and its drum is, for dispersion measurements, divided into  $150^\circ$ .

**Michelson Echelon Diffraction Grating.\***—This apparatus consists of a series of clear glass plates, each 10 mm. thick, overlapping in such a way as to form a series of "steps" each 1 mm. wide. The plates are all optically worked and should be in perfect optical contact; there may be fourteen or more mounted in a frame. A beam of parallel rays transmitted through the series of plates is, therefore, retarded by  $nt$  mm., where  $n$  is the number of plates and  $t$  their thickness. On emergence the rays are in a condition to interfere. Though the echelon can be used with almost any form of spectroscope, a special form known as the "Constant Deviation Spectroscope" is the most convenient; the chief advantage of which is that neither collimator nor telescope is ever moved, the echelon being rotated as required. Spectra of various orders can be obtained in this way and are remarkable for their brilliancy. Numerous practical details and other information are furnished.

**Visibility of Ultra-Microscopic Particles.†**—In the course of an optical investigation of various shades of ruby glass, H. Siedentopf and R. Zsigmondy devised a method of observing small particles of gold which closely approach molecular dimensions, and thus extending our range of molecular vision very considerably. The ruby glasses, examined by the best ordinary Microscopes, appeared perfectly homogeneous. But the authors reasoned that if the gold particles imbedded in the glass were at such distances apart that a Microscope could resolve them, they could be made visible even though their size should be a small fraction of the wave-length of visible light. The only condition was that the product of the specific intensity into the surface of the luminous particles and the square of the sine of the effective angle of illumination should be greater than the inferior limit of the sensitivity of the human eye. The problem is thus reduced to that of the visibility of a fixed star. What is seen is, of course, a diffraction disc, and that is all we can hope to see, but the authors indicate a means of determining the true size and weight of the particles seen.

It is essential that all disturbing side-lights should be avoided. The authors threw a beam of sunlight through a condenser on a slit 0.05 to 0.5 mm. wide, and an image of the slit was produced in the field of vision by a telescope lens and a collimator with a reduction of 36 diameters. The diffraction discs seen in the ruby glass had an average apparent diameter of 1 mm., while their real diameter, calculated from the quantity of gold present and the number of particles counted in unit volume, was  $0.02 \mu$  on the average. This gives a magnification of 50,000 diameters. The utmost limit to which the magnification can be pushed by this method is about 150,000 diameters, or  $6 \mu\mu$ . The average diameter of a molecule being  $0.6 \mu\mu$ , it cannot

\* Pamphlet by Adam Hilger, 75A Camden Road, N.W., July 1901.

† Nature, lxxii. (1903) p. 380. See Ann. d. Physik, No. 1 (1903) pp. 1-33.

be seen, even as a diffraction disc, unless its specific luminosity were ten times that of the solar molecules, or the sensitiveness of the eye were greatly increased. The cumulative effects used in photography may be resorted to, but the authors do not mention that possibility.

### B. Technique.\*

#### (1) Collecting Objects, including Culture Processes.

**Method of Detecting the Presence of *Bacillus coli communis* in Shellfish.**†—In an article on the bacterioscopic diagnosis of sewage pollution of shellfish, E. Klein describes the method he adopted for detecting the presence of *B. coli communis* in cockles and oysters. Of each batch of cockles, 12 to 24 individuals were examined, and of each batch or sample of oysters, 10, 12, and sometimes 16 or 18 individuals. In all cases the shell of the fresh and living mollusc was thoroughly brushed with a clean brush under the running tap; then it was dried with clean cloth, opened with sterile instrument, and with the juice and liquor within the shell, cultures were established. Of each of six or eight oysters, about  $\frac{1}{2}$  c.cm. of this liquor was added to one MacConkey tube and the same amount to one lactose tube; of further two, sometimes four, oysters,  $\frac{1}{5}$  c.cm. of this liquor was added to each of two, or in some cases four, phenol-broth tubes, or in lieu (in the earlier analyses) about three big drops of the juice of each of two animals to establish two litmus-glucose-agar surface plates. Next day, that is, after twenty-four hours' incubation at 37° C., the necessary subcultures were made from the original tubes and plates in order to demonstrate the presence of *B. coli communis*; streak and shake gelatin cultures, MacConkey and lactose-pepton tubes, litmus-milk, ordinary broth (with and without neutral-red), litmus, lactose-phenol-agar plates, &c. From the turbid phenol broth also microscopic specimens stained by Gram's method were made in order to detect the streptococci. Cultures on solid media may also be employed for their detection.

BOSSE, B.—Der Deykesche Pepsin-Trypsin-Agar ein Nährboden für Diphtheriebacillen. *Centralbl. Bakt.*, 1<sup>te</sup> Abt. Orig., XXXIII. (1903) pp. 471-9.

BRONGERSMA, S. H., & TH. H. VAN DE VELDE—Cultivation of *Gonococcus* on "Thalman-Agar."

[Observations confirming Thalman's results.]

See this *Journal*, 1900, p. 613.

#### (2) Preparing Objects.

**Fixation of Blood-Films and the Triacid Stain.**‡—E. S. Nutting has used for some time past Merck's methyl-alcohol for fixing blood-films. The preparations are treated with the reagent for three minutes, and then with the triacid stain for five minutes. Though the results

\* This subdivision contains (1) Collecting Objects, including Culture Processes; (2) Preparing Objects; (3) Cutting, including Imbedding and Microtomes; (4) Staining and Injecting; (5) Mounting, including slides, preservative fluids, &c.; (6) Miscellaneous

† *Brit. Med. Journ.*, 1933, i. 417-20.

‡ *Tom. c't.*, p. 196.

are not so brilliant as when the films are fixed at a temperature of 150° C., they are generally extremely satisfactory.

**Simple Device for Carrying Minute Objects through the Grades of Cedar Oil and Paraffin.\***—C. S. Gage transfers from one grade of cedar oil and paraffin to another by inclosing the object (pollinia of *Asclepias*) in little bags, made by bringing together the four corners of a square (1.5 in. by 1.5 in.) of cheese-cloth and fastening them by one or two turns of small copper wire. One end of the wire is left about one inch long and hooked at the free end. The bags can be suspended by the hooks in the bottles of oil and paraffin and thence transferred from one to another. When the imbedding stage is reached, the bags are cut from the wires, opened in the melted paraffin, and the pollinia distributed as desired. By this device excessive handling is avoided.

(3) Cutting, including Imbedding and Microtomes.

**Jung's New Student's Microtome.†**—The frame *g* of R. Jung's new pattern student's microtome (figs. 45 and 46) is fixed to the table by means of a screw-clamp *Kn*. To the upright piece *a* which moves on two screw-points *s s*, are attached the handle *H* and the knife-

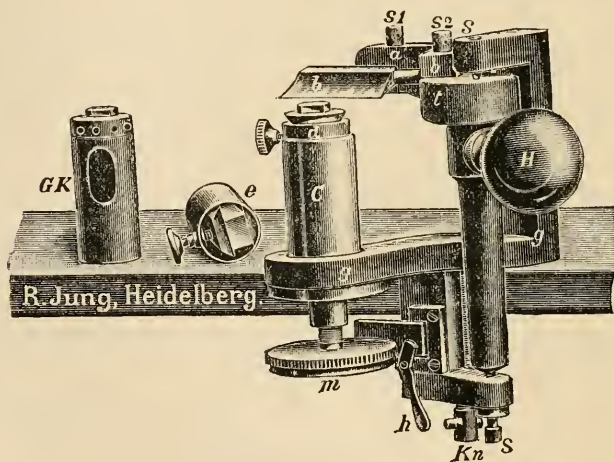

FIG. 45.

carrier *t* with its clamping jaws *a* and *b*. To the base of *g* are fitted the micrometer-screw *m* and the tube *C*, which serves as sleeve for the object-holder and the freezing apparatus. The instrument can be used

\* Journ. App. Micr., vi. (1903) p. 2115.

† R. Jung's Catalogue, 1902 (2 figs.); also Zeitschr. angew. Mikr., viii. (1902) pp. 236-43 (2 figs.).

for cutting sections of fresh tissue without imbedding, of tissue frozen by means of ethyl chloride, and of material imbedded in paraffin and celloidin.

In fig. 45 the instrument is shown with ratchet and pawl adjustment, with clamp for paraffin block, and apparatus for freezing with

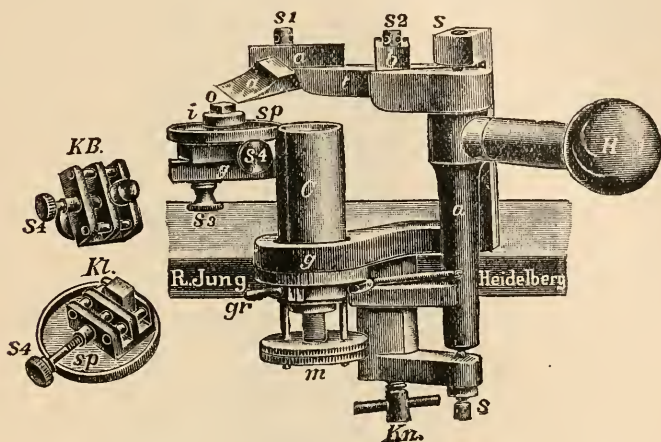

FIG. 46.

ethyl chloride. In fig. 46 the instrument is shown with obliquely placed knife, the position adapted for cutting celloidin sections and fresh hard objects. The apparatus is well supplied with the accessories necessary for fixing and holding the objects to be cut, and knives suitable for sectioning according to the method of imbedding. Full directions are given for manipulating the machine, how to set and strop the knives, and the best way to fix the knife for cutting.

**Sectioning Fresh Plant-Tissues.\***—N. B. Pierce presses a small piece of leaf or other like tissue between two flat cakes of paraffin, each being 20 mm. long, 14 mm. wide, and 3 mm. thick, taking care that the margins of the blocks coincide. A heated scalpel is then run round the edges of the blocks so as to melt them together where touched. The block is then cooled in water until it is sufficiently firm to be fixed to the microtome block and trimmed in the usual manner. In this way excellent sections, 5  $\mu$  thick, can be obtained of perfectly fresh tissue.

**Improvement in Reichert's Sliding Microtome.†**—J. Starlinger describes this new arrangement, which is clearly recognisable from fig. 47. It concerns the mechanism of the knife-slide and is intended to make it independent of the direction of gear rotation. Hitherto, the windlass H and chain have been in intimate connection, and every

\* Journ. App. Micr., v. (1902) pp. 2074-5.

† Zeitschr. f. wiss. Mikr., xix. (1902) pp. 145-7 (1 fig.).

rotation of the former produced a corresponding movement in the latter. Now, between these there are placed a larger (*b*) and two smaller toothed wheels (*h, i*), as well as another toothed segment-piece *d* ex-

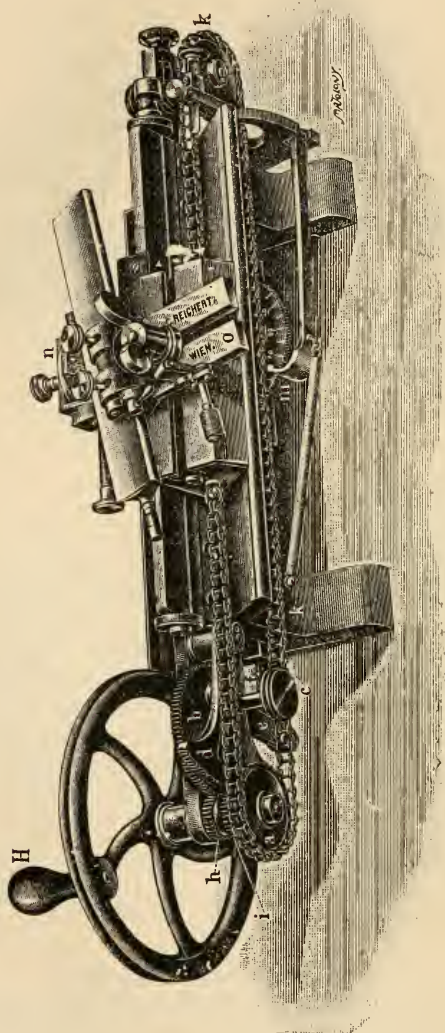

FIG. 47.

centrically connected with *b* by means of the lever *e*. The wheel *h* engages with *H*, and *i* engages with the chain-wheel *a*. The successive transmission of movement is through the toothed wheel *b*, the lever-

arm *e*, and the toothed segment *d*. By means of the excentrically applied lever the circular movement of the segment *d* is converted into an up-and-down movement, which afterwards causes the forward and backward rotation of the wheel *i*, and finally the forward and backward gliding of the knife. The connection of *d* and *e* is adjustable and can be regulated in such a way that the knife movement may extend over the whole, or part, of the slide-range. The author considers that the operator will find it an advantage to be able to rotate the wheel *H* as he pleases, and that the application of motor-gear to the microtome will be facilitated.

**New Method of Imbedding Small Objects.\*** — G. Lefevre has devised a glass dish in which small objects, e.g. Echinoderm eggs, &c. may be imbedded with great ease, and which prevents them from

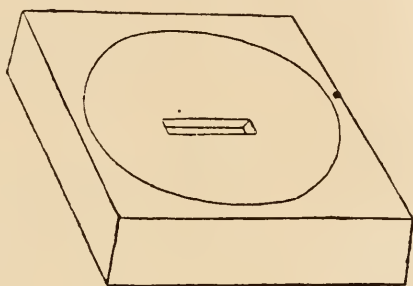

FIG. 48.

scattering. The dish is a flat solid watch-glass with a shallow concavity, in the bottom of which is moulded a narrow slot-like groove or trough (fig. 48). The dish is 40 mm. square and 9 mm. high; the

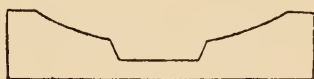

FIG. 49.



FIG. 50.

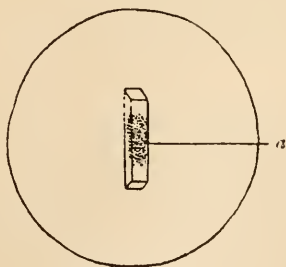

FIG. 51.

diameter of the concavity is 34 mm. and its greatest depth  $4\frac{1}{2}$  mm. The groove, which is slightly bevelled at the ends, is 11 mm. long at the bottom, 2 mm. wide, and 2 mm. deep. Fig. 49 shows a section

\* Journ. App. Micr., v. (1902) pp. 2980-1 (5 figs.).

of the glass through the long axis of the groove, and fig. 50 a section across the groove.

When the objects are ready for imbedding, they are transferred to the dish filled with melted paraffin and kept warm on the bath, by carefully dropping them from a pipette into the groove. The bottom of the dish is then rapidly cooled. When thoroughly hardened the paraffin may be removed without difficulty, and it then has the form seen in fig. 51.

**New Razor-holder and Adjustable Clamp for the Minot Microtome.\***—S. H. Gage advises the use of a razor with a straight edge and back. This is fitted in a support which will allow nearly the whole length of the cutting edge to be used, and which consists of a piece of brass resting on the knife-support of the microtome. At right angles to the base-piece on which rests the back of the razor, is a vertical back-piece against which the side of the razor rests. This is slightly narrower than the width of the razor-blade, and a notch is cut out of the middle where the sections are made. A front-piece is made like the back-piece, except that it is not fastened to the base-piece. This is put against the front side of the razor and the clamping screws of the regular knife-holder press against it.

As the Minot holders for the paraffin blocks have but very slight adjustment and are, moreover, somewhat expensive, short stove blocks were recommended to meet the requirements of a large class. But as these did not fit very often, an adjustable clamp was devised which will receive bolts differing 1 or 2 mm. in diameter. The stem which connects the clamp of the microtome has a long thread, and a solid piece is screwed upon it. A loose piece like the first is then slipped over the screw, and finally a thumb-nut is put upon the end to press the loose piece against the fixed piece. Holes are bored in the clamp, half the cylinder being in each. Either of these holes serves for the paraffin block holder. Such a clamp surmounts the difficulties of variations in the size of the stem of the paraffin holder.

DIXON, H. H.—Sectioning without Imbedding.

*Bot. School T. C. Dublin, Aug. 1902.*

#### (4) Staining and Injecting.

**Staining Directions for Photomicrography.†**—F. Crosbie remarks that the stains selected in micrography often throw great difficulties in the way of the photographer, rendering it impossible to obtain really good negatives and necessitating the use of light-filters of great depth of colour, with a corresponding diminution of actinic light-value and an increase in the length of exposure. When it is known that a specimen is to be photographed the stain should be specially selected with a view to this if possible. Hæmatoxylin is suitable for sections. Gentian-violet gives the best results with bacteria. Fuchsin should be avoided. In fact, it can be roughly stated that all stains on the blue or violet side of the spectrum answer best, and stains belonging to the red

\* *Trans. Amer. Micr. Soc.*, xxiii. (1902) pp. 259-61 (1 pl. and 7 figs.).

† *Lancet*, 1903, i. pp. 233-6 (5 figs.).



end of the spectrum give the worst results. Golgi preparations give most satisfactory negatives. Sections stained with hæmatoxylin or other blue dyes are very actinic, and it is necessary to exaggerate the shadow thrown by them. This is done by colouring the light before it enters the condenser of the Microscope, with a light filter or colour screen of a tint complementary to the stain. In most cases the screen sold by photographic dealers for landscape photography will be found sufficient; this is a light brown-yellow glass screen. Should the section be thin and the staining slight or faded, greater depth of colour will be necessary in the light-filter. This can be obtained by staining a film of gelatin on a glass plate with picric acid, or, better still, by using a glass trough or bottle filled with a solution of bichromate of potassium. The light-filter, however constructed, must be placed between the light and the Microscope. If a coloured glass screen, it is fitted into a frame which is hinged to the platform on which the Microscope stands, so that it can be raised or lowered at discretion. To this frame is also hinged a sheet of vulcanite, in order to cut off all light from the Microscope when manipulating the dark slide before and after making an exposure.

If possible, all preparations of a series to be photographed should be stained with the same dye, as this will simplify the calculations necessary to find the time of exposure, will suit one quality of plate and one light-filter, and will render possible an exact comparison of the various results and a correct relation of their several details.

**Method of Demonstrating the Secretory Canaliculi in Suprarenal Capsules.\***—C. Ciaccio fixed the fresh tissue for 15 to 20 days in Müller's fluid and then transferred the pieces to a 1 p.c. solution of nitrate of silver for 24 hours. Better results were obtained by fixing in the following mixture:—Formalin 15 c.cm.; bichromate of potassium 5 grm.; distilled water 100 c.cm. Good preparations may be obtained by cutting sections with a razor from the pieces directly removed from the silver nitrate, but paraffin sections were necessary for demonstrating the more delicate details. The sections were stained with acid fuchsin, by Zimmermann's silver chloride method, and in other ways. The animals used were guinea-pigs, rabbits, and cats. By this procedure pericellular canals having intracellular ramifications were demonstrated.

**Staining Diphtheria Bacilli and Cholera Vibrios.†**—W. G. Schaffler, in a preliminary communication, states that by means of Loeffler's methylen-blue, pyronin, and hydrochloric acid-alcohol, diphtheria bacilli from fresh membrane, or from cultures, stain easily and without the aid of heat. The poles appear red, while the rest of the cell-body is stained blue. Pure cultures of different races of cholera vibrios show on staining with methylen-blue, decolorising with hydrochloric acid-alcohol and contrast-staining with dilute pyronin, dark granules in the bluish-red bodies.

**New Method of Staining Flagella.‡**—E. Gemelli describes the following method for staining flagella. The cover-glasses are boiled in

\* Anat. Anzeig., xxii. (1903) pp. 493-7 (3 figs.).

† Allg. Med. Central-Ztg., 1902, p. 827. See Centralbl. Bakt., 1<sup>o</sup> Abt. Ref., xxxii. (1903) p. 687. ‡ Centralbl. Bakt., 1<sup>o</sup> Abt. Orig., xxxiii. (1903) pp. 316-9.

a solution consisting of 3 p.c. potassium bichromate and sulphuric acid (100 : 5), and after having been washed in water are kept in alcohol. When required for use they are picked up with horn-tipped forceps and flamed. The material used should be obtained from fresh cultures. The best are those which are solid, contain little salt, and are prepared with glycerin. A loopful of culture is placed on a watch-glass containing 5 c.cm. of distilled water, and a drop of the suspension spread over the cleaned cover-glass. The cover-glass is then placed under a bell-jar and allowed to dry slowly with the aid of calcium chloride. For staining, two solutions are required : (a) potassium permanganate 25 cg., distilled water 10 gm. (b) To a calcium chloride solution (0.75 gm. in distilled water 100 gm.) in the proportion of 20 to 1 is added a 1 p.c. solution of neutral red. The cover-glass is then laid in the potassium permanganate solution for 10 to 20 minutes, and after having been washed in distilled water is transferred to the neutral red solution for 15, 20, or 30 minutes, according to the kind of bacterium dealt with. The cover-glasses are then washed, dried with blotting-paper, and mounted in balsam.

**Staining the Reticular supporting Network of Malignant Neoplasms by Mallory's Method.\***—P. G. Woolley recommended that sections should be cut from tissue hardened in Zenker's fluid and imbedded in paraffin. These are fixed to the slide in the usual way, and then the paraffin is dissolved off and the slide immersed in absolute alcohol, 95 p.c. alcohol, 70 p.c. alcohol, then in water. Next, the sections are stained in a  $\frac{1}{10}$  p.c. aqueous acid fuchsin solution for 2-3 minutes and then washed in water. After this, the sections are treated for 5-7 minutes with a few drops of 1 p.c. solution of phospho-molybdic acid. After again washing in water the sections are stained with a solution composed of anilin-blue 0.5 gm., orange G 0.2 gm., oxalic acid 2 gm., water 100 c.cm. This is allowed to act for about 20 minutes, after which the slides are rinsed in water and then hurriedly dehydrated with 95 p.c. alcohol. Finally, the sections are treated with a drop or two of anilin oil which is allowed to remain on until the sections are clear. It is then removed with blotting-paper, and the sections having been treated with xylol are mounted in balsam. By this method the finest reticular processes can be seen clearly and distinctly.

**Staining Reactions of Proteid Crystals.†**—J. A. Milroy finds that albumin crystals, prepared by the method of Hopkins and Pinkus, after treatment with trichloroacetic acid have a selective affinity for acid as distinguished from basic anilin dyes. If, however, they are further treated with alcohol they become capable of taking up either acid or basic dyes. In the latter case the staining is to be regarded as a physical phenomenon, while in the former it is largely chemical.

**Improved Method for the Microscopical Diagnosis of Intermittent Fever.‡**—Ronald Ross recommends the following method by which a thick film of blood is treated in a manner which does away with

\* Johns Hopkins Hosp. Bull., xiv. (1903) pp. 21-4 (3 figs.).

† Proc. Scot. Micr. Soc., iii. (1901-1902) pp. 252-7.

‡ Lancet, 1933, i. p. 86.

the obscuring effect of the massed corpuscles. The method depends on the fact that the parasites adhere to the stromata of the containing capsules, after the hæmoglobin has been washed out of the films. A thickish film of blood is spread on a slide over an area which can be covered by the ordinary slip. It is then dried in the air or over the flame. The dried film is then covered with aqueous solution of eosin which is allowed to act for about a quarter of an hour. The film is then gently washed to remove the superfluous eosin and at the same time the hæmoglobin. The film is then treated with a weak solution of methylen-blue for a few seconds. After washing the film it is dried and mounted in balsam. Prepared in this way the films show about twenty times the number of parasites as are found in preparations of the same blood made in the ordinary way.

**Method for Demonstrating Nematocyst Cells in Hydra.\***—E. O. Little puts living hydras in a Stender dish with a small amount of water. A boiling-hot mixture of saturated solution of sublimate in 70 p.c. alcohol is then poured into the dish. This kills the hydras in full extension. After washing several times in 70 p.c. alcohol, the animals are passed through 50 p.c. alcohol, 35 p.c. alcohol, and water successively, after which they are stained for 5 minutes in the following solution:—Methylen-blue 1 gm., Castile soap 0.5 gm., water 300 c.cm. The animals are then passed hurriedly through the alcohols of the following strengths: 30, 50, 70, 85, 90, 100 p.c., then cleared in cedar or bergamot oil and mounted in balsam. The nematocyst cells are stained deep blue, all other cells are unstained; exploded nematocyst cells do not stain.

**New Method of Staining Bacterial Granules.†**—M. Ficker recommends a staining solution consisting of methylen-blue Höchst 1–10,000, lactic acid 2 p.c. The solution is made by dissolving 1 gm. of methylen-blue in 100 c.cm. of distilled water and mixing 1 c.cm. thereof with 100 c.cm. of distilled water. To 100 c.cm. of the last solution 2 c.cm. of lactic acid are added. With this staining solution a fresh unfixed bacterial suspension, placed on a slide and covered with a slip, is treated by sucking the stain through with the aid of blotting-paper and repeating the process several times if necessary. By this procedure two or three dark blue granules appear, the rest of the bacterial cell remaining unstained.

**Easy Method of Staining the Flagella of Bacteria.‡**—G. L. Valenti says that just as good results can be obtained from gelatin, potato and bouillon cultures, as from young agar cultures. The films are prepared from emulsions in the usual way, and when carefully dried may be kept for months before being used. The mordant used is a 20 p.c. solution of tannic acid in distilled water, and the staining solution Ziehl's fuchsin. The point of the method is to mix the mordant and staining solution. The film is just covered with the mordant, then three drops of the Ziehl's fuchsin solution are added. The cover-glass or slide is then heated, and after having cooled is washed with water, dried, and mounted in balsam.

\* Journ. App. Micr., vi. (1903) p. 2116.

† Hygien. Rundschau, 1902, p. 1131. See Centralbl. Bakt, 1<sup>o</sup> Abt. Ref., xxxii. (1903) p. 723.

‡ Centralbl. Bakt., 1<sup>o</sup> Abt. Ref., xxxii. (1903) pp. 744-6.

### Apparatus for Facilitating the Manipulation of Celloidin Sections.

R. Hamlyn-Harris writes that anyone who has had experience in preparing, staining, and mounting a series of celloidin sections will have appreciated the difficulties of manipulation and of keeping each section in its proper order and of staining each uniformly. It was while considering this subject, and having to deal with an object, the individual sections of which had to be carefully mounted in successive order, that the apparatus (fig. 52) suggested itself to the writer's mind.

It will not be difficult to gather from the illustration that the apparatus consists of separate compartments, each of which represents a cell capable of holding one or more sections. These are handled either by a small brush moistened in 80 p.c. alcohol, or by an ordinary section-

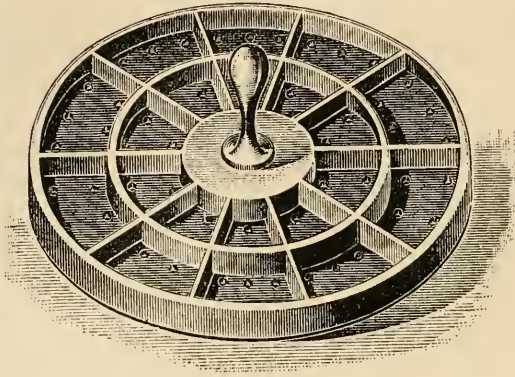

FIG. 52.

lifter, and placed into each cell successively. The whole apparatus and contents can then be submerged in 80 p.c. alcohol until wanted.

By means of the handle the whole appliance can be taken out of one kind of fluid and placed in another without moving the sections from their respective cells. Care is needful that they do not get washed out of the partitions in the transfer from one fluid to another. This may be prevented by the use of a small brush, and should any section rise to the surface, it can be easily replaced in position. The body of the appliance is formed of one piece of a non-corroding metal, while the bottom is made of brass. The diameter of the apparatus is  $3\frac{1}{2}$  in.; the plate is  $\frac{3}{16}$ -in. thick and the partitions  $\frac{1}{8}$ -in. thick. Measured from the outside the height of the sides is  $\frac{1}{8}$  in. and that of the handle  $\frac{2}{8}$  in. The handle can be unscrewed and removed. In each compartment there is a perforation to allow the fluid to escape when the transfer is made from one fluid to another.

No further description is necessary as every microscopist will see at once the advantages claimed for the invention. It has been exceedingly useful to the writer and he hopes it may be of service to others. If the apparatus were made in a square form and if suitable glass vessels could be got to fit it, a greater advantage would result, as space for several

more compartments would thereby be gained. The appliance described possesses twenty compartments, but from experience I have found that this number is sufficient. Could some transparent substance, such as glass or mica, be used in its construction, so as to enable differentiation to be carried out under the Microscope, it would be a great boon, but all attempts to get this accomplished have so far failed.

DIETERICH, K.—*Mikroskopische Technik des Zentralnervensystems.*

[A review of general methods, of special methods of staining nerve-cells, medullary sheaths, axis-cylinders, neuroglia, and nuclei.]

*Zeitschr. angew. Mikr.*, VIII. (1902) pp. 225-36.

EHRlich, P., R. KRAUSE, M. MOSSE, H. ROZIN, & C. WEIGERT—*Encyclopädie der mikroskopischen Technik mit besonderer Berücksichtigung der Färbelehre.* Parts i. and ii., with numerous illustrations.

Berlin and Vienna, 1903.

GRIMME, A.—*Die wichtigsten Methoden der Bakterienfärbung in ihrer Wirkung auf die Membran, den Protoplasten und die Einschlüsse der Bakterienzelle.*

*Centralbl. Bakt.*, 1<sup>o</sup> Abt. Orig., XXXII. (1902) pp. 1-16, 81-90, 161-80, 241-55, 321-7 (2 pls.).

(5) Mounting, including Slides, Preservative Fluids, &c.

Slide for Pond Life.\*—S. E. Dowdy describes a convenient slide for studying the life-histories of aquatic microscopic organisms and pond life in general, similar in principle to Botterill's. It may be constructed as follows. Select a vulcanite cell-ring of small diameter and medium thickness, and cut it in half. Cement the two portions with gold size or coaguline in the centre of a 3 by 1 in. slide, so that a narrow channel is left on each side of the circle (fig. 53). Pick out

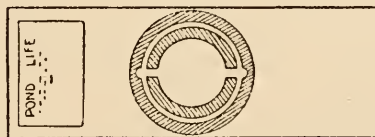

FIG. 53.

a cell-ring of sufficient diameter to just encircle the other and rather thicker than the first one. Cement this down round the other and notch out the portions resting against the channels in the inner ring. A thin circular cover-glass which will just fit into the larger cell-ring completes the arrangement.

Fresh water can be put in on one side with a pipette and any excess drawn up at the opposite channel with a roll of blotting-paper. The cover-glass can be lifted easily by inserting a needle under it through one of the small openings. A slide of this description can be utilised also in bacteriological work for studying hanging-drop cultivations, excess of air, if necessary, being prevented by painting round the edges of the cover-glass with vaseline.

\* *Engl. Mech.*, lxxvii. (1903) p. 13 (1 fig.).

## (6) Miscellaneous.

**Biological Laboratory Methods.\***—P. H. Mell's text-book, though specially intended for the use of students in biological laboratories, will be found extremely serviceable by workers with the Microscope in other branches of science. Its scope is highly practical and the information is conveyed in clear and simple language. The first three chapters deal with the Microscope, eye-pieces, objectives, and accessory apparatus. Then follow four chapters on the methods necessary for transforming a piece of soft tissue into its permanent condition of a stained and mounted section.

Much space is devoted to photomicrography, the apparatus and processes being described in considerable detail.

The last chapters deal with the apparatus and methods requisite for bacteriology, bleaching, decalcification, injection and maceration, the polarisation of light and its application to biological investigations; the work concluding with a copious supply of useful formulæ and tables, and an appendix on the arrangement of the laboratory and its furniture.

The volume is well got up, is of convenient size, and the illustrations are clear and frequent.

**Counting the Red Corpuscles of the Blood.†**—C. A. MacMunn showed at the meeting of the Physiological Society on January 17, lantern slides illustrating how the counting of the red corpuscles can be done by photographing fresh films. The blood is diluted to half or to 1 p.c. in the Thoma-Zeiss hæmocytometer. Not only are the red corpuscles seen on the plate but also the rulings of the cell-slide. The most suitable power was found to be a  $\frac{3}{4}$  in. objective and a Zeiss eye-piece No. 4, with a 6-in. tube-length. This method enables a permanent record of blood-counts to be kept, and also to make the enumeration at any time. Of course, the Microscope and camera are used in the vertical position.

**Fusible Metal Stopper for Test-tubes.‡**—F. Glage recommends "fusible metal" for sealing up test-tubes as they are cleaner than resin or paraffin. The alloy melts on boiling water and when heated over the flame drops off like sealing-wax. If dropped on to a glass plate thin disks, about the size of a shilling, are formed. These disks are easily manipulated, and by the aid of a little heat made to fit over the mouth of test-tubes with great accuracy.

**GREVILLIUS, A. Y.**—Keimapparat zur Erhaltung konstanter Feuchtigkeit im Keimbette während einer beliebig langen Zeit.

*Beih. Bot. Centralbl., Orig.-Arb., XII. (1902) pp. 289-92 (1 fig.).*

**KAUSCH, O.**—Neuerungen auf dem Gebiete der Desinfektion und Sterilisation.

*Centralbl. Bakt., 1<sup>o</sup> Abt. Ref., XXXII. (1903) Nos. 24 and 25.*

\* Macmillan & Co., London and New York, 1902, xii. and 321 pp. and 128 figs.

† *Nature*, lxxvii. (1903) p. 327.

‡ *Centralbl. Bakt., 1<sup>o</sup> Abt. Orig., xxxiii. (1903) p. 479.*

## PROCEEDINGS OF THE SOCIETY.

## MEETING

HELD ON THE 18TH OF FEBRUARY, 1903, AT 20 HANOVER SQUARE, W.  
DR. HENRY WOODWARD, F.R.S., PRESIDENT, IN THE CHAIR.

The Minutes of the Anniversary Meeting of the 21st of January, 1903, were read and confirmed, and were signed by the President.

The President said that before proceeding with the ordinary business of the Meeting he had to announce the death of a very old Fellow and past President of the Society, Mr. James Glaisher, at the advanced age of 93. He then gave a sympathetic *résumé* of Mr. Glaisher's scientific career and of his connection with the Royal Microscopical Society.

The List of Donations to the Society, exclusive of exchanges and reprints, received since the last Meeting, was read, and the thanks of the Society were voted to the donors.

Lambert, F. C., Bromide Printing. (Svo, London, 1902) ..	From The Publishers.
Mell, P. H., Biological Laboratory Methods. (Svo, London, 1902) ..	The Publishers.
Smith, G. R., Enlargements, their Production and Finish. (Svo, London) ..	The Publishers.
Frankland, Mrs. Percy, Bacteria in Daily Life. (Svo, London, 1903) ..	The Publishers.
Geological Magazine, Nos. 403-464. (Svo, London, 1898-1903)	Mr. F. Justen.
Subject List of Works on General Science, Physics, Sound, Music, Light, Microscopy, and Philosophical Instruments in the Library of the Patent Office. (Svo, London, 1903)	The Comptroller-General of Patents.
Thirtieth Annual Report of the Local Government Board, 1900-01. Supplement in continuation of Report of the Medical Officer for 1900-01. (Svo, London, 1903) ..	The Local Government Board.

Mr. F. Orfeur exhibited an interesting old Microscope with apparatus complete, which appeared to be very similar to that known as Jones's Microscope of 1798, and figured in "Carpenter." As the Society did not possess an example of this instrument, Mr. Orfeur said he had much pleasure in presenting this one to add to their collection.

On the motion of the President the thanks of the Society were voted to Mr. Orfeur for exhibiting, describing, and presenting this Microscope to the Society.

The Secretary said they had received some material from Mr. Hilton, which had been collected at the North Cape by the light of the mid-April 15th, 1903

night sun. This was offered for distribution amongst the Fellows of the Society, and portions could be obtained on application to Mr. Parsons.

The thanks of the Society were voted to Mr. Hilton.

---

The President said he had great pleasure in introducing Dr. A. W. Rowe, F.G.S., who had kindly consented to give them a demonstration "On the Photomicrography of opaque objects, as applied to the delineation of the minute structure of chalk fossils." Dr. Rowe had published some very important memoirs on 'The Zones of the Chalk,' and had examined it very carefully all round the coast from Beer Head, Devonshire, to Flamborough Head, in fact wherever it was exposed, and he very strongly recommended his published memoirs to the attention of the Fellows who take an interest in geology.

Dr. Rowe said he had been invited to come before the Society on that occasion to demonstrate upon the screen some of the possibilities of photomicrography, and as a means of exhibiting the structure of opaque objects of small size but possessing considerable details of a very instructive although very minute character. As regarded photomicrography of transparent objects itself, most people now know something about this, and if they did not practise it themselves they were quite conversant with the results of the process. Great attention had been given to it of late years, so that it might now be said to have become a finished art; opticians vied with one another in producing lenses and apparatus of the highest excellence, and the process had become not only greatly simplified, but capable of producing extremely beautiful effects. The photomicrography of opaque objects was, however, quite a different matter from that of transparent objects, for though its broad principles seemed to be simplicity itself, as soon as they began to try it they would find that it was beset with difficulties quite unknown to those who had only practised transparent photomicrography. In the production of the photographs exhibited that evening, he had used objectives of various powers from  $1\frac{1}{2}$  in. to 6 in. according to the size of the object or the details he wished to show, and in photographing some of these he used a long camera with a Zeiss' planar lens. As regarded light, there was considerable choice, lime-light, electric, acetylene gas, and others, but he had ultimately fallen back upon incandescent gas-light as being, upon the whole, the best for the purpose. In practice, it was soon found that the question of success entirely hinged upon getting a good contrast of light and shade, the whole thing being in fact a matter of tricks of illumination. As regarded time of exposure, with a 3 to 10 mm. diaphragm, he found that a good picture could under favourable conditions be obtained in 20 seconds, but that this might extend to as much as 3 or 4 minutes at the outside, for specimens which were not very white. He found that the light from the mantle of an ordinary incandescent gas-burner gave a good margin to work with, which was very useful in cases where the plate was under-exposed; mere speed was no object. In addition to the difficulty in getting exactly the right position for the best effects of light and shade to be produced, a great obstacle arose from the fact that the objects to be dealt with were not flat, causing considerable trouble both in the matter of focussing and of the incidence



of the light. As to the advantage of photomicrography over eye observations, every observer was aware that after a time the eye and the brain became fatigued, and the power of minute observation was for the time being exhausted, whereas, with the photographic prints before them, there was no fatigue felt and the details could be studied with comfort. Then again, it helped the draughtsman to understand what he was asked to represent, in a way quite impossible otherwise when he had to rely upon description alone; and further than this, the cheapness of this method of illustration was to most persons a very obvious advantage. The preparation of the specimens of course required some amount of care, although chalk was perhaps not a very difficult substance to deal with. In treating comparatively minute objects he usually cut away as much as possible with a knife, and if he wished to get a fossil out whole, he undercut it from both sides, until it was detached without fear of breakage, and then he got his dental engine to work, and in this manner cleaned away all that was not wanted.

A large number of photographs of various fossils, prepared in the manner stated, were then shown upon the screen with great brilliancy by means of the Epidiascope, brief descriptive remarks being made and the chief points of interest indicated as the exhibition proceeded.

The President said he felt sure it was hardly necessary to ask them to pass a very hearty vote of thanks to Dr. Rowe for his most interesting and instructive communication, and for the exhibition of the very beautiful series of lantern slides shown on the screen, and photographs exhibited on the table. Dr. Rowe was what might be called an "all-round" man: he goes out to the different localities and finds the fossils, brings them home, works them out with his dental engine, then works at them further with the Microscope and the camera, publishes papers upon them, and also produces the results of his researches in the manner which they had seen that evening. The Society owed him a great debt for the very valuable communication which he had made.

A hearty vote of thanks to Dr. Rowe was then put and carried by acclamation.

Dr. Rowe said he thanked the President for his kind remarks, and the Fellows of the Society for the patient attention and the vote of thanks they had passed. It had been a great delight to him to attend the meeting, and to show them the results of the time which he had spent upon this subject, much of which he feared had been taken from that when he ought to have been in bed.

---

The President said that the Meeting which was announced last month, was held at the Natural History Museum on Saturday the 14th inst., when not a very large number of Fellows attended. This, however, he had been reminded might to some extent have been due to his suggestion, that if a large number came they might not all be able to hear. He hoped those who were present felt repaid for their trouble.

Mr. Vezey said that as one of those who attended on the occasion he should like to say that those who were present had a very delightful time. Dr. Woodward gave a most interesting description of the objects exhibited; he dealt chiefly with invertebrata, but he gave a sort of general

promise, that on some future occasion the visit might be repeated when he would give a similar description of the vertebrata. Mr. Vezey hoped that if such an occasion presented itself, a large number of the Fellows would find it possible to be present, and he assured them they would have a great treat. The Society was greatly indebted to the President for his kindness in taking the trouble to attend at the Museum.

Mr. Wesché, as one of those also on whom Dr. Woodward's benediction had fallen, could heartily endorse Mr. Vezey's remarks.

The President reminded the Fellows that another visit to South Kensington was arranged for March 14, to meet at 2 p.m. at the Owen statue, when Mr. Carruthers would conduct them through the Botanical Department, calling special attention to the collection of Diatomaceæ, and to a wonderful series of unpublished drawings of Botanical Studies of great beauty and interest.

The following Instruments, Objects, &c., were exhibited:—

Dr. Arthur W. Rowe:—A large number of Lantern Slides shown on the screen, and photographs exhibited on the table in illustration of his Lecture.

Mr. Frank Orfeur:—An old Microscope.

**New Fellows:**—The following were elected *Ordinary* Fellows:—Messrs. Maurice Blood, Frederick Charles Luck, and David Powell.

## MEETING

HELD ON THE 18TH OF MARCH, 1903, AT 20 HANOVER SQUARE, W.  
DR. HENRY WOODWARD, F.R.S., PRESIDENT, IN THE CHAIR.

The Minutes of the Meeting of the 18th of February, 1903, were read and confirmed, and were signed by the President.

The List of Donations to the Society, exclusive of exchanges and reprints, received since the last Meeting, was read, and the thanks of the Society were voted to the donors.

	From
Portrait of the President, from the original by Mr. Borough Johnson .. .. .	The President.
Schulze, F. E., An Account of the Indian Triaxouia. Translated from the German by R. von Lendenfeld. (Calcutta, 4to, 1902)	The Author.
Brearley and Ibbotson, The Analysis of Steel-Works Materials. (London, 8vo, 1902) .. .. .	The Publishers.
Encyklopädie der Mikroskopischen Technik. 2 vols. (Berlin and Wien, 8vo, 1903) .. .. .	The Publishers.
Braithwaite, Dr. R., The British Moss Flora. Part xxii. .. ..	The Author.

Mr. C. F. Rousselet exhibited, for Messrs. Staley & Co., a new pattern Microscope, manufactured by the Bausch and Lomb Optical Co. specially for laboratory purposes. Mr. Rousselet remarked that

Messrs. Bausch and Lomb had sent this new model of their Continental Microscope for exhibition. It seemed to be a very substantial, well made stand, with japanned horse-shoe base, and intended for use in the laboratories. It had coarse rack adjustment and a fine adjustment of the triangular bar form, with graduated head-screw. The stage was square and plain and had a vulcanite top and the usual clips which might with advantage be replaced by a simple sliding bar.

The substage condenser was carried by a screw arm attached to the side of the stage, by means of which the whole can be swung out. The condenser was of the Abbe non-achromatic type, and had an iris diaphragm below the back lens, and also one above the front lens. The latter can only be useful when the condenser is removed and the mirror used without a condenser, and then it should be racked down some little distance below the stage to be effective.

Below the condenser there was also a ring carrying a stop for dark-ground illumination, and a blue glass disk.

---

Mr. Pillischer exhibited a very old Microscope which had recently been sent to him for repair. It had a very peculiar form of stage consisting of three oval plates, having rectangular apertures moving eccentrically on the fixed stage, and he thought the Fellows of the Society might be interested in seeing it. He had not met with one like it for thirty years.

This stage was known as the "Tomes" stage. Mr. Charles Tomes (afterwards Sir Charles Tomes, F.R.S., &c., Surgeon Dentist to the Middlesex Hospital) was the inventor and for some years it was very popular with medical men as an inexpensive and handy form of apparatus, especially for dissecting purposes. As far as can be traced it was first made about 1847, and remained popular for about ten years. This Microscope belonged to the late Sir William White-Cooper, Ophthalmic Surgeon to Her late Majesty the Queen, and has now been put in working order for the use of his grandson.

---

The President said they were to have that evening a very interesting communication from Mr. J. W. Gordon on the Helmholtz theory of the Microscope. He thought it was possible that, although many people had some idea of who Helmholtz was, they might not know very much as to what his life's work had been, and he had therefore prepared a short account of this distinguished German philosopher, which he read as follows :—

HERMANN LUDWIG FERDINAND VON HELMHOLTZ (1821-1894).\*

Originally a mathematician (by choice) he, by necessity, became a surgeon in the Prussian army, and contributed important papers to science from 1842 to 1894, the year of his death. Was Professor of Physiology at Königsberg from 1849 till 1855, when he removed to the

\* New vols. Encyc. Britannica, xxix. (1902) pp. 247-8.

University of Bonn ; was Professor at Heidelberg from 1858 till 1871, when he was appointed to the Chair of Physics at Berlin. This, as well as that at Charlottenburg from 1887, he held till his death in 1894.

His investigations occupied the whole field of science. In 1851, he discovered and invented the "*ophthalmoscope*" which has been of inestimable service in medicine. It arose through his attempt to demonstrate to his class the nature of the glow of reflected light sometimes seen in the eyes of animals such as the cat. When the great ophthalmologist von Graefe first saw the fundus of the living human eye, with its optic disk and blood-vessels, he exclaimed, "Helmholtz has unfolded to us a new world !"

Helmholtz' contributions to physiological optics are of great importance. He investigated the optical constants of the eye, measured by his invention, "the *ophthalmometer*," the radii of curvature of the crystalline lens for near and far vision, explained the mechanism of accommodation by which the eye can focus, within certain limits, discussed the phenomena of colour vision, and gave a luminous account of the movements of the eyeballs so as to secure single vision with two eyes.

In particular he revived and gave new force to the theory of colour-vision associated with the name of Thomas Young, showing the three primary colours to be red, green, and violet, and he applied the theory to the explanation of colour-blindness.

His great work on *Physiological Optics* (1856-66) is by far the most important book that has appeared on the physiology and physics of vision.

Mr. J. W. Gordon said that from its length and character it would be impossible for him to read the paper *in extenso*, but he thought that as proof copies of it were in the hands of many persons present at the Meeting they would be sufficiently acquainted with its contents to make it easy to follow the argument. He therefore proposed merely to give a summary of its contents. In the first place, it gave a very rough sketch of the theory of diffraction, and proceeded to consider this from a somewhat new point of view, expanding the Helmholtz theory from this position. The paper then went on to deal with the Helmholtz theory, starting with the proof of the "sine law" given in Helmholtz' own paper, in pure mathematical form. This, Mr. Gordon had endeavoured to set forth under the guise of an experiment. Having proved the sine law, Helmholtz next proceeded to make deductions from it, and in particular to draw the inference that the resolving power of even the most perfect optical system must necessarily stop short at an object which was less than half a wave-length of the light by which it was perceived. Mr. Gordon then in the course of a speech of one hour and twenty minutes set out the points of his own paper, illustrating his remarks by diagrams shown upon the screen and by drawings on the board. Several Microscopes upon the table, to which a mechanical arrangement of moving screens had been adapted, were employed in further illustration of a portion of the subject.

The President said that the way in which the Fellows of the Society had received this communication made it quite unnecessary to ask them for any expression as to their appreciation of it. Those who had seen

the paper would be still better aware of what an elaborate work Mr. Gordon had undertaken, and the great pains he had been at to bring this subject completely before them.

Prof. Wright, being called upon by the President to make some remarks upon the subject before them, said he feared he had nothing of any importance to add as he himself had sat at Mr. Gordon's feet as a learner for a long time past; but there were certain points alluded to in this paper which struck him as being of direct practical interest to all professional workers with the Microscope. The dimensions of the beam which entered the eye appeared to be of great importance in connection with ocular fatigue. Where the beam was large enough to occupy to a large extent the opening of the iris—and this was the case when a wide-angled objective and a low eye-piece were used—a person could work all day long with the Microscope without fatigue. There was no more ocular fatigue under these conditions than in looking at objects in the ordinary way with the unaided vision. Where, on the contrary, a narrow-angled objective and a high ocular were employed, giving a very narrow beam, fatigue was very soon felt. Superadded to ocular fatigue associated with the employment of a narrow beam, there was of course the inconvenience resulting from obtruding spots in the eye-piece and muscæ volitantes in the eye. The next point which he felt it important for them to realise was the fact that the beam which comes out of the eye-piece to enter the eye is inversely proportional to the magnifying power employed. The initial size of the transmitted beam depended of course on the aperture of the beam which was received into the objective. The wide-angled objective derived much of its importance from the fact that it furnishes the large initial beam which was essential where high magnification was desired. The progressive diminution of the beam as greater and greater magnification was achieved had seemed to be of the nature of an insuperable difficulty. [This was illustrated by a diagram on the board, showing that the opening out and closing down of the terminal beam was by an action similar to that of the lazy tongs, rigidly governed by the opening out and closing down of the initial beam.] Mr. Gordon by his device of the interposed screen had, so to speak, unhinged the lazy tongs, at the joint where the links became unduly narrow, or if we choose to put it so, bent out the limbs of the joint. He had in this way secured to us a wider emergent beam. The last point to which he desired to refer related to the importance of the step that was taken by Mr. Gordon when he cut himself loose from the ordinary optical diagram representing only the axial beam, and took into consideration the case of beams traversing the objective obliquely, and Mr. Gordon had satisfactorily shown by the demonstrations now on the table before them that the elimination of these oblique rays in the case where they were cut down by the edge of the post-objective diaphragm, was a matter of enormous importance to the achievement of critical definition. In ordinary bacteriological work—carried on as it usually was with a wide-angled oil-immersion objective, and a condenser of a somewhat similar aperture, used without the immersion fluid—the conditions were in point of fact conditions that allowed the oblique beams from the periphery of the field to pass

through the objective unmutilated. For the beam which emerged from the radiant point in the object was, under the specified conditions, always narrower than the aperture of the objective. Being such, it passed through unmutilated, even when it was disposed obliquely to the axis of collimation. As very clearly pointed out by Mr. Gordon, the marginal zone of unoccupied objective, which Mr. Nelson has shown to be essential to critical definition, allows room for the unmutilated passage of oblique beams.

Mr. Gifford said he should like to have some further information as to the oscillating screens mentioned by Mr. Gordon and exhibited in the room. Mr. Gordon spoke of three oscillations per second, and he should like to understand what these were and what was the amount of the displacement. So far as he could judge, the effect seemed to be due not only to the number of vibrations per second, but also to the distance travelled by any given point on the screen at each excursion to and fro.

Mr. C. Beck said he had the advantage of seeing this apparatus working quietly a few days before, and in case there might be any difficulty in using it to advantage in a crowded room, he should like to mention that he examined a slide of *angulatum* with the screen in action and with the screen removed, and found that the definition with the screen was enormously better with a high-power eye-piece than it was without the screen. It was quite possible with the oscillating screen to see the hexagons clearly. He thought extreme credit was due to Mr. Gordon for thinking out such a plan, which was not obviously a result of Prof. Helmholtz's paper, but was a matter upon which an enormous amount of thought had been expended. He must, however, protest against Mr. Gordon's elaboration of the sine condition. It might be a prejudice of his, but he had always thought it only applied to images on the axis of the system, and that it was an impossibility to produce an extended collinear image with wide-angled pencils as a tangent condition was essential to this result. It had also been suggested to him that it was Prof. Abbe who was responsible for the sine-law before it was enunciated by Prof. Helmholtz, and if this was so it did not seem quite fair to Abbe to give the whole credit to Helmholtz.

Mr. Conrady thought this was evident from the postscript of Helmholtz' paper, of which he gave the following translation :—

“The above paper was completely finished and ready for despatching, when, at the last moment, I came across Prof. E. Abbe's ‘Contributions to the Theory of the Microscope and of Microscopical Vision’ as published in the April number of 1874 of the ‘Archiv für mikroskopische Anatomie.’ This paper contains a preliminary collection of the results of extensive investigations—partly theoretical and partly experimental—which to a great extent coincide with what I have given here. The theorems on the divergence of rays, on the magnitude of diffraction in Microscopes, and on the brightness of their images, which form the foundation of my conclusions, have been found by Prof. Abbe, but are published for the present without proof. But in addition his paper contains a short account of important investigations of diffraction in the microscopical objects themselves with narrow illuminating pencils. The special festive occasion on which this volume of the ‘Annalen’ is pub-

lished prevents me from retaining my paper or from entirely withdrawing it. As it contains the proofs of the theorems used by both of us, not yet supplied by H. Abbe, and also a few simple experiments as illustrations of the theoretical investigations, its publication may appear excusable even from a scientific standpoint."

Mr. Conrady also tried to show that Mr. Gordon had not given Helmholtz' proof of the sine-law at all, but only a theorem first found by Lagrange, and applying to centred optical systems generally and limited to negligibly small divergence-angles, and that Helmholtz deduced the sine-law for finite divergence angles from the first theorem by integration, which latter Mr. Gordon had not given in his paper. He further insisted that the sine-law was strictly applicable only to a surface element in the optical axis and was only an approximation when applied to objects of considerable size. In his opinion Abbe's rendering of the sine-law was the one which should appeal most to practical microscopists; for as Abbe had shown that a lens offending against the sine-law had different magnifying powers for different zones of its aperture, it must be quite clear that there must be intolerable confusion in the image produced by such a lens, especially as he could assure those present that the difference of magnifying power might amount to 10 or even 20 p.c. difference between the central and marginal zones if the sine-law was not taken into consideration.

Mr. Conrady thought that the old term "spurious disk" was a far better and more expressive one than the one "antipoint" which Mr. Gordon wished to have substituted, seeing that the image of a luminous point was not a point at all but just the spurious disk which it had hitherto been called.

Finally Mr. Conrady expressed his most emphatic doubts that the mutilation of oblique beams by successive diaphragms should or could under any conceivable circumstances produce the distorted spurious disks near the centre of the field which Mr. Gordon had tried to demonstrate, seeing that adjoining elements of structure, such as pleurosigma dots, subtended angles of only a few seconds of arc.

Dr. Lindsay Johnson, in reply to the President, said he had no intention of speaking, but perhaps he might just say a word or two in connection with the subject which came more within his own province, for the admirable exposition of the sine theorem, the oscillating screens, and diffraction points had been so ably put by Mr. Gordon that it would be absurd for him to attempt to criticise. Some time ago he was trying to focus upon the screen of a camera some words on a poster which were too far off for him to read the letters in question, but he found that by rapidly oscillating the screen it became quite easy to read the letters. He sometimes had patients brought to him who were suffering from what was known as Miner's nystagmus, a disease, the chief symptom of which being a peculiar trembling of the eyes, induced by constantly directing the eyes obliquely in a confined situation and a dim light. This was nature's way of doing what Mr. Gordon had done by means of his oscillating screens. Having to work with only such faint light as was given by a Davy lamp, the tendency for these afflicted people was to get better vision by this tremulous movement of their eyes, which by

constant habit became automatic and involuntary in the same way as Mr. Gordon had independently obtained it by mechanical means. Nature has contrived this oscillation of the eye in order that a second cone may receive the same image before the same impression has died out from the first cone, and again a fresh impression on the first cone before the impression produced by the second one had died away, so that in this way the combined stimulus of several cones may suffice to convey the impression to the brain which the feebler action upon one cone would be insufficient to effect.

Mr. Rheinberg said they had been hearing a great deal about the formation of images so far as the optical system was concerned, but nothing about the part played in this respect by the object itself, which after all was important. Supposing they had *isolated* objects of no appreciable depth, such as bacteria, then there might under suitable illumination be a considerable analogy between them and luminous points or lines. If, however, they had objects having a certain depth and consisting of separated elements, then they had entirely different conditions whereby the image of certain of the elements might be modified by adjacent ones.

Referring to the limit of separating power, was it not a difficult matter to make out the case for anything less than half a wave-length? In speculations of this nature they required to take physiological conditions into consideration. It was partly a question of the sensitiveness of the eye to different degrees of luminosity, and this was also affected by the size of the surfaces compared with the very small distance separating them. If the surfaces were bright and relatively large, the eye would not distinguish the interval between them in the same way as if isolated points were in question. He had noticed in the diagrammatic illustrations of overlapping antipoints on the screen, that these had been represented as of the same luminosity throughout, whereas of course in reality they fell off very greatly in brightness towards their edges, which would materially modify the illustration.

As regarded moving screens in the focal plane of the eye-piece, he inquired of Mr. Gordon, whether and what means were taken to ensure the various parts of the screen moving at an equal rate, because if revolving simply, the edge parts of the screen would be moving so much faster than the central parts. Whilst he much admired the ingenuity of the idea of the moving screen, he could not follow the utility of the plan, because they could not thereby get any greater resolving power than they had in the objective to start with. It appeared to him that what was proposed, could be managed much more easily: for to obtain the same sized image, and avoid any disadvantages connected with the smallness of the Ramsden circle, they had only to use a lower eye-piece and move the photographic screen further away. He should be very pleased to hear Mr. Gordon's opinion on these matters.

Mr. Gordon said he desired to thank the Fellows of the Society for the kind reception they had given to his paper and to acknowledge the indebtedness he felt to them for their patience in listening to his somewhat lengthy remarks. In particular he wished to acknowledge his great



obligation to Mr. Beck for the loan of apparatus for the purpose of the demonstration, and to Mr. E. Russell Clarke—a stranger to the Society—who had kindly lent him the Microscope which they saw upon the table, fitted with an electrically driven screen. Mr. Clarke unfortunately was not able to attend that evening, and he (Mr. Gordon) had not succeeded in getting the Microscope to work properly. He hoped, however, on some future occasion Mr. Clarke would be able to attend to give the Fellows a demonstration of the working of his very beautiful instrument. With reference to Mr. Gifford's inquiry as to the displacement of the screens, in the case of Mr. Russell Clarke's arrangement, the oscillation was perfectly regular, describing a long ellipse, the magnitude of the longer axis being about three times that of the shorter, the long axis measuring about  $\frac{1}{100}$  in. In the case of the other screens exhibited on the table, Fellows would be able to see the motion for themselves as one of them was working opened up. Care had been taken to provide against any chance of a repeated pattern. The screen was moved in a circle by a ring embracing it, but was so much smaller than the ring, that it rolled within the ring, the result being a sort of epicyclic motion. He thought Mr. Rheinberg would find there was no difficulty in getting rid of all trace of the screen, in photography; and in answer to Mr. Beck, he said that he had fully committed himself to the exposition of the sine-law—if that were in any respect erroneous it could be criticised. He should be very sorry to do any injustice to Prof. Abbe, but had not attempted to trace the original statement of the sine-law. The only thing with which he was concerned in that paper was the proof of the law, and the proof of it was admittedly due to Helmholtz, except for Hockin's defective proof which was discussed in the appendix to the paper. Mr. Conrady had taken exception to the term "antipoint." That was a matter which he would not discuss as Mr. Conrady was clearly entitled to his opinion on such a point. With reference to the opinion which Mr. Conrady had expressed that the sine-law only applied to a small element of surface lying on the optical axis, he suggested that if that were his view Mr. Conrady would do well to read Helmholtz' paper. It was no doubt possible to have an optical system in which the tangent law took the place of the sine-law. That was, however, all dealt with in the appendix to the paper, and as it was written out there it would not be necessary to refer to it further. Mr. Rheinberg complained that nothing was said about the optical properties of the object: that was because Helmholtz said nothing about them. Much might no doubt be said about the object, but Helmholtz in his paper treated not of the object but of the instrument interposed between the object and the eye. It was not to be supposed that an oscillating screen could increase the resolving power of an objective. What he did was to preserve the integrity of the image formed by the objective when greatly super-amplified by eye-piece magnification. So with regard to the use of an oscillating screen in photomicrography. The finely resolved image on a large scale could be obtained by means of a projection ocular and an optical bench. The object of using the screen was to get rid of these cumbersome accessories, and obtain the high magnification at a short distance from the stage by means of a compounding draw-tube.

The President said that he could only repeat that they were very much indebted to their Fellow, Mr. Gordon, for this very excellent communication. Those who had been privileged to listen to the Author's able résumé of his paper might have obtained some idea of Helmholtz' theory of the Microscope, but they would be glad to know that they would have the opportunity of reading the paper *in extenso* for themselves when printed in the *Journal*.

---

The President announced that Mr. Fletcher, of the Mineral Department of the Natural History Museum, would be delighted to give a demonstration of Mineralogy to those Fellows of the Society who wished to visit the Natural History Museum on April 18, meeting, as before, at the Owen statue at 2 o'clock. He was quite sure that those who accepted the invitation would find that Mr. Fletcher was able to make the subject a most interesting and attractive one, as he had a happy way of describing what was to be seen, so that those who listened to his remarks on the wonderful collection of minerals under his charge would be sure to derive both pleasure and profit.

---

**The following Instruments, Objects, &c., were exhibited:—**

Mr. J. Pillischer :—A Microscope made by M. Pillischer about 1847, fitted with Sir Charles Tomes' stage.

Mr. J. W. Gordon :—Experiments with seven Microscopes (lent by Messrs. Beck) in illustration of his paper, and a Microscope (lent by Mr. Russell Clarke) fitted with electric illuminating apparatus and an electrically driven screen.

Mr. Rousselet :—A Bausch and Lomb "B B Continental Microscope" sent for exhibition by Messrs. A. E. Staley & Co.

---

**New Fellows:—**The following were elected *Ordinary* Fellows of the Society :—Rev. James Feather, Messrs. Frederick E. Ives, J. Inderwick Pigg, and Joseph Henry Scott.





W. W. Millett del. ad nat.

West, Newman lith.

Foraminifera of Malay Archipelago

JOURNAL  
OF THE  
ROYAL MICROSCOPICAL SOCIETY.  
JUNE 1903.

---

TRANSACTIONS OF THE SOCIETY.

---

IV.—*Report on the Recent Foraminifera of the Malay Archipelago collected by Mr. A. Durrand, F.R.M.S.—Part XIV.*

By FORTESCUE WILLIAM MILLETT, F.R.M.S.

(Read April 17th, 1903.)

PLATE V.

*Cristellaria* Lamarck.

*Cristellaria Schloenbachi* Reuss.

*Cristellaria Schloenbachi* Reuss, 1862, Sitzungsber. k. Akad. Wiss. Wien, vol. xlvi. p. 65, pl. vi. figs. 14, 15. *C. Schloenbachi* (Reuss) Flint, 1899, Rep. U.S. Nat. Mus. for 1897 (1899), p. 315, pl. lxiii. fig. 4. *C. Schloenbachi* (Reuss) Egger, 1899, Abhandl. k. bayer. Akad. Wiss., Cl. II. vol. xxi. p. 110, pl. xii. figs. 38-40; pl. xxiv. figs. 30, 31.

---

EXPLANATION OF PLATE V.

- Fig. 1.—*Cristellaria variabilis* Reuss. × 100.  
 „ 2.—*Amphicoryne glabra* sp. n. × 70.  
 „ 3. „ *Bradyi* A. Silvestri sp. × 90.  
 „ 4. „ *falz* Parker and Jones sp. × 70.  
 „ 5.—*Polymorphina lactea* var. *oblonga* Williamson. × 60.  
 „ 6.—*Dimorphina lingulinoides* sp. n. × 90.  
 „ 7.—*Uvigerina canariensis* d'Orbigny var. × 90.  
 „ 8, 9. „ *Auberiana* d'Orbigny, var. *glabra* var. n. × 90.  
 „ 10.—*Sagrina columellaris* Brady. × 75. Microspheric form.  
 „ 11. „ „ × 75. Megalospheric form.  
 „ 12-15. „ *nodosa* Parker and Jones. × 90.  
 „ 16. „ *tessellata* Brady. × 75.  
 „ 17. „ *limbata* Brady. × 70. From a drawing by C. Elcock.  
 „ 18, 19. „ „ „ × 75. Specimens from Raine Island.

June 17th, 1903

In the Pacific Ocean the genus *Cristellaria* is very sparingly distributed, and there are few records of its occurrence in the equatorial region or in the North Pacific.

In Mr. Durrand's collection, although the genus is represented by several species, the individuals are few and ill-developed.

*C. Schloenbachi* possessing characters common to both *Vaginulina* and *Cristellaria* comes naturally as a connecting link between the two genera.

It occurs sparingly at Stations in both Areas, and is not uncommon at Station 30.

'Challenger' Stations are off Bermuda, 435 fathoms; off Culebra Island, 390 fathoms; and off Raine Island, 155 fathoms. Flint records it from two Stations in the Gulf of Mexico, at depths of 169 and 210 fathoms.

*Cristellaria crepidula* Fichtel and Moll sp.

*Nautilus crepidula* Fichtel and Moll, 1803, Test. Micr., p. 107, pl. xix. figs. *g-i*. *Cristellaria crepidula* d'Orbigny, 1839, Foram. Cuba, p. 64, pl. viii. figs. 17, 18. *C. crepidula* (F. and M.) Jones, 1884, Quart. Journ. Geol. Soc., vol. xl. p. 770, pl. xxxiv. fig. 8. *C. crepidula* (F. and M.) Balkwill and Millett, 1884, Journ. Micr., vol. iii. p. 84, pl. iv. fig. 8. *C. crepidula* (F. and M.) Sherborn and Chapman, 1886, Journ. R. Micr. Soc., ser. ii. vol. vi. p. 753, pl. xv. fig. 21. *C. crepidula* (F. and M.) Halkyard, 1889, Trans. and Ann. Rept. Manchester Micr. Soc., p. 67, pl. ii. fig. 5. *C. dilatata* Wisniowsky, 1890, Pamietnik Wydz. iii. Akad. Umiej-Krakowie, vol. xvii. p. 31, pl. ix. fig. 10; and *C. dorsoarcuata* p. 31, pl. ix. fig. 11. *C. crepidula* (F. and M.) Haeusler, 1890, Abhandl. schweiz. pal. Gesell., vol. xvii. p. 111, pl. xiv. fig. 59; pl. xv. figs. 1, 18. *C. crepidula* (F. and M.) Fornasini, 1890, Mem. R. Accad. Sci. Ist. Bologna, ser. 4, vol. x. p. 471, pl. figs. 31-33, 56-60. *C. crepidula* (F. and M.) Egger, 1893, Abhandl. k. bayer. Akad. Wiss., Cl. II. vol. xviii. p. 350, pl. xi. figs. 51, 52; pl. xii. figs. 34, 35. *C. crepidula* (F. and M.) Fornasini, 1894, Mem. R. Accad. Sci. Ist. Bologna, ser. 5, vol. iv. p. 220, pl. iii. fig. 10. *C. crepidula* (F. and M.) Goës, 1894, K. Svenska Vet.-Akad. Handl., vol. xxv. p. 62, pl. xi. figs. 599, 600. *C. crepidula* var. *intermedia* Burrows and Holland, 1897, Proc. Geol. Assoc., vol. xv. p. 40, pl. i. fig. 11; var. *cymboides*, pl. i. figs. 1-3; var. *subarcuatula*, pl. i. fig. 17; var. *harpa*, pl. i. figs. 12, 18-21. *C. crepidula* (F. and M.) Flint, 1899, Rep. U.S. Nat. Mus. for 1897 (1899), p. 316, pl. lxiii. fig. 2. *C. crepidula* (F. and M.) Egger, 1899, Abhandl. k. bayer. Akad. Wiss., Cl. II. vol. xxi. p. 110, pl. xxiii. figs. 21, 22; pl. xxv. figs. 27, 28.

Very few specimens of this form have been observed, and these are of the *subarcuatula* type.

It occurs in both Areas.

*Cristellaria acutaureicularis* Fichtel and Moll sp.

*Nautilus acutaureicularis* Fichtel and Moll, 1803, Test. Micr., p. 102, pl. xviii. figs. g-i. *Cristellaria acutaureicularis* (F. and M.) Parker and Jones, 1860, Ann. and Mag. Nat. Hist., ser. 3, vol. v. p. 114, No. 20. *C. acutaureicularis* (F. and M.) Sherborn and Chapinan, 1886, Journ. R. Micr. Soc., ser. 2, vol. vi. p. 753, pl. xv. fig. 22. *C. acutaureicularis* (F. and M.) Haeusler, 1890, Abhandl. schweiz. pal. Gesell., vol. xvii. p. 113, pl. xv. fig. 17. *C. acutaureicularis* (F. and M.) Crick and Sherborn, 1891, Journ. Northamptonshire Nat. Hist. Soc., vol. vi. p. 212, pl. fig. 25; and 1892, vol. vii. pl. ii. figs. 17, 18. *C. acutaureicularis* (F. and M.) Egger, 1893, Abhandl. k. bayer. Akad. Wiss., Cl. II. vol. xviii. p. 353, pl. xii. figs. 19, 20. *C. acutaureicularis* (F. and M.) Flint, 1899, Rep. U.S. Nat. Mus. for 1897 (1899), p. 316, pl. lxiii. fig. 5. *C. acutaureicularis* (F. and M.) Chapman, 1900, Quart. Journ. Geol. Soc., vol. lvi. p. 259, pl. xv. fig. 9.

The examples of this species are small and pass imperceptibly into *C. gibba*.

It occurs at several Stations in both Areas, but always in small numbers.

In the recent condition this is by no means a common form, although it has a very wide range. Besides the localities mentioned by Brady it has been recorded by Egger from Mauritius, and by Flint from two Stations off the Atlantic coast of the United States.

*Cristellaria gibba* d'Orbigny.

*Cristellaria gibba* d'Orbigny, 1826, Ann. Sci. Nat., vol. vii. p. 292, No. 17. *C. gibba* d'Orbigny, 1839, Foram. Cuba, p. 40, pl. vii. figs. 20, 21. *C. gibba* (d'Orb.) Burrows, Sherborn, and Bailey, 1890, Journ. R. Micr. Soc., p. 259, pl. x. figs. 19, 21. *C. gibba* (d'Orb.) Crick and Sherborn, 1891, Journ. Northamptonshire Nat. Hist. Soc., vol. vi. p. 212, pl. fig. 29. *C. gibba* (d'Orb.) Egger, 1893, Abhandl. k. bayer. Akad. Wiss., Cl. II. vol. xviii. p. 352, pl. xii. figs. 21, 27. *C. gibba* (d'Orb.) Silvestri, 1893, Mem. Pontif. Accad. Nuovi Lincei, vol. ix. p. 207, pl. vi. fig. 4. *C. gibba* (d'Orb.) Goës, 1894, K. Svenska Vet.-Akad. Handl., vol. xxv. p. 61, pl. x. figs. 287, 288. *C. gibba* (d'Orb.) Fornasini, 1894, Mem. R. Accad. Sci. Ist. Bologna, ser. 5, vol. iv. p. 221, pl. iii. fig. 20. *C. gibba* (d'Orb.) Jones, 1895, Palæont. Soc., p. 247, pl. vii. fig. 19. *C. gibba* (d'Orb.) Chapman, 1896, Journ. R. Micr. Soc., p. 4, pl. i. fig. 7. *C. gibba* (d'Orb.) Burrows and Holland, 1897, Proc. Geol. Assoc., vol. xv. pp. 44, 45, pl. ii. figs. 5, 6. *C. gibba* (d'Orb.) Flint, 1899, Rep. U.S. Nat. Mus. for 1897 (1899), p. 317, pl. lxiv. fig. 1. *C. gibba* (d'Orb.) Chapman, 1900, Journ. Linn. Soc. (Zool.) vol. xxviii. p. 31,

pl. v. fig. 13 ; and Proc. California Acad. of Sci., ser. 3, Geol., vol. i. p. 251, pl. xxx. fig. 3.

This species is rather more plentiful than *C. acutaureicularis*, and its distribution is much the same.

Brady records notes of its occurrence in the North Atlantic and the South Pacific. Silvestri has found it in the Mediterranean, and Egger at Mauritius, West Australia, and New Guinea ; whilst Flint adds the Gulf of Mexico to the list of localities.

*Cristellaria italica* Defrance sp.

*Saracennaria italica* Defrance, 1824, Dict. Sci. Nat., vol. xxxii. p. 177 ; 1827, vol. xlvi. p. 344 ; Atlas Conch., pl. xiii. fig. 6. *Cristellaria (Saracennaria) italica* (Defr.) d'Orbigny, 1826, Ann. Sci. Nat., vol. vii. p. 293, No. 26 ; and Modèles, Nos. 19 and 85. *C. italica* (Defr.) Sherborn and Chapman, 1886, Journ. R. Micr. Soc., ser. 2, vol. vi. p. 754, pl. xv. fig. 23 ; pl. xvi. fig. 4. *C. italica* (Defr.) Egger, 1893, Abhandl. k. bayer. Akad. Wiss., Cl. II. vol. xviii. p. 350, pl. xii. figs. 22, 23, 26, 40-42. *C. italica* (Defr.) Chapman, 1894, Journ. R. Micr. Soc., p. 653, pl. x. fig. 10. *C. italica* (Defr.) Fornasini, 1894, Mem. R. Accad. Sci. Ist. Bologna, ser. 5, vol. iv. p. 219, pl. iii. fig. 8 ; and 1895, vol. v. p. 12, pl. iv. fig. 28. Idem, 1895, Palæont. Italica, vol. i. p. 145, pl. vii. fig. 10. *C. italica* (Defr.) Flint, 1899, Rep. U.S. Nat. Mus. for 1897 (1899), p. 316, pl. lxiii. fig. 6.

In the Malay Archipelago this is a very rare form and has been observed only at Station 12 in Area 1.

To the numerous list of localities mentioned by Brady, Egger adds West Australia ; and Flint records it from the coast of Georgia and the Gulf of Mexico.

*Cristellaria variabilis* Reuss, plate V. fig. 1.

*Cristellaria variabilis* Reuss, 1849, Denkschr. k. Akad. Wiss. Wien, vol. i. p. 369, pl. xlvi. figs. 15, 16. *C. variabilis* (Reuss) Brady, Parker, and Jones, 1888, Trans. Zool. Soc., vol. xii. p. 224, pl. xliv. fig. 12. *C. variabilis* (Reuss) Burrows, Sherborn, and Bailey, 1890, Journ. R. Micr. Soc., p. 560, pl. x. fig. 22. *C. Bradyana* Procházka, 1893, Vestník král. české spol. náuk. Třída Math., p. 44, pl. xi. fig. 5. *C. variabilis* (Reuss) Egger, 1893, Abhandl. k. bayer. Akad. Wiss., Cl. II. vol. xviii. p. 353, pl. xii. figs. 16-18. *C. variabilis* (Reuss) Goës, 1894, K. Svenska Vet.-Akad. Handl., vol. xxv. p. 62, pl. x. figs. 593-595. *C. variabilis* (Reuss) Flint, 1899, Rep. U.S. Nat. Mus. for 1897 (1899), p. 316, pl. lxiii. fig. 1.

There are several examples of this form from Station 25 in Area 2, and it also occurs at Station 13 in Area 1. The specimens



are small and ill-developed, none of them attaining the carinate stage.

Brady states that it is by no means uncommon from 100 to 600 fathoms; Egger records it from four Stations at depths of from 37 to 650 fathoms; Goës from 126 fathoms; and Flint from six Stations, 68 to 196 fathoms.

*Cristellaria rotulata* Lamarck sp.

*Lenticulites rotulata* Lamarck, 1804, Ann. Mus., vol. v. p. 188, No. 3; and 1806, vol. viii. pl. lxii. fig. 11. *Cristellaria rotulata* d'Orbigny, 1840, Mém. Soc. Géol. Fr., sér. i. vol. iv. p. 26, pl. ii. figs. 16-18. *C. rotulata* (Lam.) Brady, Parker, and Jones, 1888, Trans. Zool. Soc., vol. xii. p. 224, pl. lxiv. fig. 15. *C. rotulata* (Lam.) Burrows, Sherborn, and Bailey, 1890, Journ. R. Micr. Soc., p. 559, pl. x. fig. 17. *C. rotulata* (Lam.) Haeusler, 1890, Abhandl. schweiz. pal. Gesell., vol. xvii. p. 114, pl. xv. figs. 7, 8, 10, 12, 13. *C. rotulata* (Lam.) Terrigi, 1891, Mem. R. Com. Geol. Italia, vol. iv. p. 95, pl. iii. fig. 8. *C. rotulata* (Lam.) Beissel (Holzapfel), 1891, Abhandl. k. Preuss. geol. Landesanst., N.F., Heft 3, p. 55, pl. i. figs. 2, 3; pl. x. figs. 20-43. *C. rotulata* (Lam.) Perner, 1892, Česká Akad. Císaře Františka Josefa (Palæont. Bohemicae No. 1) p. 62, pl. iv. figs. 1-11. *C. rotulata* (Lam.) Crick and Sherborn, 1892, Journ. Northamp. Nat. Hist. Soc., vol. vii. p. 70, pl. ii. fig. 14. *C. rotulata* (Lam.) A. Silvestri, 1893, Atti e Rendic. Accad. Sci. Lett. e Arti dei Zelanti e P.P. dello Studio di Acireale, vol. v. p. 14. pl. iii. figs. 22, 23. *C. rotulata* (d'Orb.) Egger, 1893, Abhandl. k. bayer. Akad. Wiss., Cl. II. vol. xviii. p. 351, pl. xii. figs. 1, 2, 32, 33. *C. rotulata* (Lam.) Fornasini, 1893, Mem. R. Accad. Sci. Ist. Bologna, ser. 5, vol. iii. p. 435, pl. ii. fig. 11; and 1894, vol. iv. pp. 221, 222, pl. iii. figs. 24, 25. *C. rotulata* (Lam.) Goës, 1894, K. Svenska Vet.-Akad. Handl., vol. xxv. p. 60, pl. x. figs. 559-578. *C. (Lenticulites) rotulata* (Lam.) Egger, 1895, Naturhist. Ver. Passau, Jahresber., xvi. p. 26, pl. iii. figs. 4-7. *C. rotulata* (Lam.) Fornasini, 1895, Palæont. Italica, vol. i. p. 146, pl. vii. fig. 12. *C. rotulata* (Lam.) Chapman, 1896, Journ. R. Micr. Soc., p. 5, pl. i. fig. 8. *C. rotulata* (Lam.) Flint, 1899, Rep. U.S. Nat. Mus. for 1897 (1899), p. 314, pl. lxiv. fig. 4. *C. rotulata* (Lam.) Egger, 1899, Abhandl. k. bayer. Akad. Wiss., Cl. II. vol. xxi. p. 122, pl. xi. figs. 3, 4. *C. rotulata* (Lam.) Chapman, 1900, Journ. Linn. Soc. (Zool.), vol. xxviii. p. 32, pl. v. fig. 14; and Proc. California Acad. of Sci., ser. 3, Geol. vol. i. p. 251, pl. xxx. fig. 4.

Brady speaks of this as one of the most widely diffused of all the foraminifera. In the Malay Archipelago it is one of the rarest and has been observed only at Station 25 in Area 1.

*Cristellaria calcar* Linné sp.

*Nautilus calcar* Linné, 1767, Syst. Nat., 12th ed., p. 1162, No. 272. *N. calcar* (Linné) Fichtel and Moll, 1803, Test. Micr., p. 69, pl. xi. figs. *a, b, c*; pl. xii. figs. *i, k*; pl. xiii. figs. *c, d, h, i*. *Cristellaria calcar* (Linné) Parker and Jones, 1857, Ann. and Mag. Nat. Hist., ser. 2, vol. xix. p. 289, pl. x. figs. 10-12. *C. calcar* (Linné) Brady, Parker, and Jones, 1888, Trans. Zool. Soc., vol. xii. p. 224, pl. xlv. fig. 14. *C. calcar* (Linné) Terrigi, 1891, Mem. R. Com. Geol. Italia, vol. iv. p. 96, pl. iii. fig. 16. *C. calcar* (Linné) Egger, 1895, Naturhist. Ver. Passau, Jahresber., xvi. p. 27, pl. iii. figs. 1, 2. *C. calcar* (Linné) Dervieux, 1896, Mem. Pontif. Accad. Nuovi Lincei, vol. xi. pl. xiv. fig. 5. *C. calcar* (Linné) Flint, 1899, Rep. U.S. Nat. Mus. for 1897 (1899), p. 318, pl. lxvi. fig. 1. *C. calcar* (Linné) Egger, 1899, Abhandl. k. bayer. Akad. Wiss., Cl. II. vol. xxi. p. 123, pl. xi. figs. 17, 18. *C. calcar* (Linné) Fornasini, 1902, Mem. R. Accad. Sci. Ist. Bologna, ser. 5<sup>a</sup>, vol. x. p. 46, fig. 45.

Found only at Station 2 in Area 1. The examples, although few and small, are characteristic; the varieties *a* and *k* of Fichtel and Moll both being represented.

*Cristellaria costata* Fichtel and Moll sp.

*Nautilus costatus* Fichtel and Moll, 1803, Test. Micr., p. 47, pl. iv. figs. *g, h, i*. *Cristellaria costata* (F. and M.) Parker and Jones, 1860, Ann. and Mag. Nat. Hist., ser. 3, vol. v. p. 113, No. 19. *C. costata* (d'Orb.) Crick and Sherborn, 1891, Journ. Northamp. Nat. Hist. Soc., vol. vi. p. 213, pl. fig. 20. *C. arimincensis* (d'Orb.) Fornasini, 1894, Mem. R. Accad. Sci. Ist. Bologna, ser. 5, vol. iv. p. 223, pl. iii. figs. 36-38. *C. costata* (F. and M.) Fornasini, 1895, Palæont. Italica, vol. i. p. 146, pl. vii. fig. 13. *C. costata* (F. and M.) Silvestri, 1899, Mem. Pontif. Accad. Nuovi Lincei, vol. xv. p. 218, pl. i. fig. 13. *C. costata* var. *spinata* Schubert, 1899, Sitzungsber. Deutsch. naturw.-med. Ver. für Bohmen, "Lotos" No. 6, p. 16, pl. v. fig. 7.

Simply because they are ribbed, two very different forms have been associated under this name. The *Nautilus costatus* of Fichtel and Moll is lenticular and may be described as being a variety of *Cristellaria calcar* bearing concentric costæ. Closely allied, if not identical with this, is the *Robulina arimincensis* of d'Orbigny.

The *Cristellaria costata* of d'Orbigny represented by Modèle No. 84, is a more elongated form, and as interpreted by subsequent authors is nothing more nor less than a costate *Marginulina* or *Vaginulina*. Of this variety good examples from the lias are figured by Brady, 1867, and by Crick and Sherborn, 1891.

In the Malay Archipelago it has been observed only at Station 13 in Area 1, and the few examples are small and of arrested growth.

There are three 'Challenger' Stations for this form given by Brady: off Gomera, Canaries, 620 fathoms; off Kandavu, Fiji, 210 fathoms; and off Raine Island, Torres Strait, 155 fathoms. He also states that it has been reported from the shores of the Adriatic, at Rimini and Lido.

*Amphicoryne* Schlumberger.

Of all the compound forms this is perhaps the most difficult to deal with in a satisfactory manner, for not only is it in many instances hard to determine the genera of the component parts, but there are numerous monstrosities which so nearly resemble the types that it is difficult to distinguish between them.

Although this genus was instituted to include the forms compounded of *Cristellaria* and *Nodosaria*, the *Cristellarian* portion, so far as has been observed, is always of the *crepidula* type and consequently passes by imperceptible degrees into the genus *Vaginulina*. It is doubtful if any good purpose would be served by the adoption of the genus *Nodosariopsis*, and although Prof. Silvestri is quite in order in giving a generic name to the combination of *Vaginulina* and *Nodosaria*, in practice there would be a great difficulty in keeping the two genera distinct; besides this, there would be the inconvenience of removing the species *falsa* from the genus *Amphicoryne*, of which it has hitherto been considered the type. In this state of uncertainty it will perhaps be convenient to assign to *Amphicoryne* all the forms having the initial portion *Cristellarian* or *Vaginuline*.

*Amphicoryne glabra* sp. n., plate V. fig. 2.

*Cristellaria subarcuatula* (Walker) Williamson, 1858, Rec. Foram. Gt. Britain, p. 30, pl. ii. fig. 57. *Marginulina obstipa* var. A Terquem, 1868, Bull. Soc. Hist. Nat. Moselle, vol. xi. p. 129, pl. viii. fig. 26. ? "Dimorphous specimen, the earlier chambers arranged as in *Cristellaria*, the later ones as in *Polymorphina*," Brady, 1884, Chall. Rept., pl. lxxi. fig. 10.

Surface of test smooth; earlier portion, a compact variety of *Cristellaria crepidula*; later portion resembling *Dentalina communis*. Length 0.90 mm.

This smooth form is very rare in the Malay Archipelago, and has been found only at Station 30 in Area 2.

It is quite possible that the three figured examples referred to in the above list of synonyms may be monstrosities, rather than members of the genus *Amphicoryne*. Williamson writes of his example, "Fig. 57 represents a curious monstrosity, in which the

development by gemmation has proceeded in the ordinary way through a succession of segments, but in the last two the direction has been reversed, their septal orifices being situated on the opposite margin to that which they occupy in all the preceding ones, the curvature of the shell and direction of the septal lines being likewise reversed." But the figure shows that in addition to the change of direction there is a change of character, the compact initial portion of the test being succeeded by two inflated chambers which may be assigned either to *Dentalina* or *Marginulina*. The *Marginulina obstipa* of Terquem differs from the other figured examples in having the aperture situated in a phialine neck. The form figured by Brady is still more doubtful, but there seems to be no particular reason why the terminal chamber should be assigned to *Polymorphina* rather than to *Dentalina*.

*Amphicoryne Bradyi* A. Silvestri sp., plate V. fig. 3.

"Intermediate specimen with Vaginuline commencement and final Nodosarian chamber," Brady, 1884, Chall. Rept., explanation of plate, pl. lxvi. fig. 20. *Nodosariopsis bradyi* A. Silvestri, 1902, Atti Accad. Pontif. Nuovi Lincei, anno lv. p. 53.

The strong resemblance between the example here figured and the 'Challenger' specimen, renders it highly improbable that both should be monstrosities. Brady's figure just indicates the spines which are so conspicuous a feature in the specimen from the Malay Archipelago.

It is exceedingly rare and has been found only at Station 25 in Area 2.

*Amphicoryne falx* Parker and Jones sp., plate V. fig. 4.

*Marginulina falx* Parker and Jones, 1860, Quart. Journ. Geol. Soc., vol. xvi. p. 302, No. 28. *Amphicoryne falx* (P. and J.) Brady, 1884, Chall. Rept., p. 556, pl. lxv. fig. 7-9; ? pl. cxiii. fig. 13. *Nodosaria scalaris* var. *caudata* A. Silvestri, 1893, Mem. Pontif. Accad. Nuovi Lincei, vol. ix. p. 204, pl. iv. fig. 2. *Amphicoryne falx* (P. and J.) A. Silvestri, 1899, Mem. Pontif. Accad. Nuovi Lincei, vol. xv. p. 221, pl. iii. fig. 4. *Nodosariopsis falx* (J. and P.) A. Silvestri, 1902, Atti Accad. Pontif. Nuovi Lincei, anno lv. p. 49, figs. 1-3, 9.

This form is a little less rare than the others, but it occurs only at Station 30 in Area 2. The Malay Archipelago examples are delicately striated, whilst those from other localities have the Nodosarian portion strongly costate. In some of the Mediterranean examples and in the specimen from the Italian pliocene figured by Silvestri the Cristellarian portion is smooth, whilst the succeeding chambers are costate. Of this character also is the example

figured in the 'Challenger' Report, pl. cxiii. fig. 13, which appears to correspond with the definition of the genus more closely than any of the other figured specimens, yet at p. 556 Brady, for some reason or other, says that it is obviously nothing more than a monstrosity.

According to Brady it is not uncommon in the Mediterranean at depths of less than 400 fathoms; and occurs also off the Cape of Good Hope, 150 fathoms; on the western shores of New Zealand, 275 fathoms; and off Raine Island, Torres Strait, 155 fathoms.

Silvestri records it from off the east coast of Sicily, 164 to 602 fathoms; and fossil from the pliocene of Sienna.

### Sub-family **Polymorphinæ**.

#### *Polymorphina* d'Orbigny.

##### *Polymorphina lactea* Walker and Jacob sp.

"*Serpula tenuis ovalis lævis*" Walker and Jacob, 1784, Test. Min., p. 2, pl. i. fig. 5. *Serpula lactea* Walker and Jacob (*vide* Kammacher), 1798, Adams's Essays, 2nd ed. p. 634, pl. xiv. fig. 4. *Polymorphina lactea* (W. and J.) Williamson, 1858, Rec. Forum. Gt. Britain, p. 70, pl. vi. fig. 147. *P. lactea* (W. and J.) Burrows, Sherborn, and Bailey, 1890, Journ. R. Micr. Soc., p. 561, pl. xi. fig. 9. *P. lactea* (W. and J.) Crick and Sherborn, 1892, Journ. Northamp. Nat. Hist. Soc., vol. vii. p. 71, fig. 25. *P. lactea* (Walker and Jones) Egger, 1893, Abhandl. k. bayer. Akad. Wiss., Cl. II. vol. xviii. p. 308, pl. ix. figs. 8, 14, 15; and *P. elegantissima* (P. and J.) p. 308, pl. ix. fig. 16. *P. lactea* (W. and J.) Chapman, 1896, Journ. R. Micr. Soc., p. 9, pl. ii. fig. 3. *P. lactea* (W. and J.) Morton, 1897, Proc. Portland Soc. Nat. Hist., vol. ii. p. 119, pl. i. fig. 7.

This cosmopolitan form occurs at several Stations in both Areas, but the examples are always small and wanting in character.

##### *Polymorphina amygdaloides* Reuss sp.

*Globulina amygdaloides* Reuss, 1851, Zeitschr. deutsch. geol. Gesell., vol. iii. p. 82, pl. vi. fig. 47. *Polymorphina amygdaloides* Reuss, 1855, Sitzungsber. k. Akad. Wiss. Wien, vol. xviii. p. 250, pl. viii. fig. 84. *P. amygdaloides* (Reuss) Burrows and Holland, 1897, Proc. Geol. Assoc., vol. xv. p. 46, pl. ii. fig. 18. *P. amygdaloides* var. *lepida* Fornasini, 1901, Mem. Accad. Sci. Ist. Bologna, ser. 5, vol. ix. p. 72, fig. 24; and var. *terquemiana*, p. 72, fig. 25.

This compressed variety of *Polymorphina lactea* is much more abundant than the type and occurs at a greater number of Stations.

Usually the sutures are more depressed than in the figures given by Reuss, consequently the chambers are more inflated.

*Polymorphina lactea* var. *oblonga* Williamson, plate V. fig. 5.

*Polymorphina lactea* (W. and J.) var. *oblonga* Williamson, 1858, Rec. Foram. Gt. Britain, p. 71, pl. vi. fig. 149. *P. oblonga* (Will.) Brady, Parker, and Jones, 1870, Trans. Linn. Soc., vol. xxvii. p. 222, pl. xxxix. fig. 7. *P. oblonga* (Will.) Terquem, 1875, Ess. Anim. Plage Dunkerque, part i. p. 37, pl. v. fig. 11. *P. formosa* Egger, 1893, Abhandl. k. bayer. Akad. Wiss., Cl. II. vol. xviii. p. 440, pl. ix. figs. 17-19.

This is an intermediate variety connecting *P. lactea* with *P. compressa*, and must not be confounded with the *P. oblonga* of d'Orbigny, which resembles an elongated *P. problema*. The example figured well represents the normal form, with the exception that it possesses a supplementary chamber of a Nodosarian character. This is evidently a monstrosity, otherwise the specimen would have to be assigned to the genus *Dimorphina*. This chamber appears to have nothing in common with the fistulose extraneous growths so frequently found in the *Polymorphinæ* generally, but rare or unknown in the examples from the Malay Archipelago.

*P. lactea* var. *oblonga* occurs in more or less abundance at several Stations in both Areas.

Of its distribution generally Brady, Parker, and Jones write, "The geographical range of *P. oblonga* seems to be limited; it is most abundant on the Devonshire and Cornwall coast, and may be found sparingly distributed at intervals all round the British Islands. We are not aware of its occurrence in the seas of warmer latitudes or in a fossil condition."

*P. formosa* is recorded by Egger from Cape Verde Islands, 38 fathoms; and from West Australia, 196 fathoms.

As a fossil it is not uncommon in the tertiary beds of St. Erth.

*Polymorphina compressa* d'Orbigny.

"*Polymorpha subovalia*" Soldani, 1791, Testaceographia, vol. i. part 2, p. 114, pl. cxiv. fig. F; pl. cxv. fig. N; pl. cxvi. fig. X. *Polymorphina compressa* d'Orbigny, 1846, For. Foss. Vienne, p. 233, pl. xii. figs. 32-34. *P. aff. amygdala* Deecke, 1886, Mém. Soc. émul. Montbéliard, sér. 3, vol. xvi. p. 37, pl. i. fig. 20. *P. polygona* Terquem, 1886, Mém. Soc. Géol. France, sér. 3, vol. iv. p. 63, pl. xiii. fig. 18. *P. lactea* (W. and J.) Dawson, 1886, Handbook Zoology, p. 44, fig. 34. *P. compressa* (d'Orb.) Mariani, 1888, Boll. Soc. Geol. Italia, vol. vii. p. 288, pl. x. fig. 13. *P. compressa* (d'Orb.) Egger, 1893, Abhandl. k. bayer. Akad. Wiss., Cl. II. vol. xviii. p. 309, pl. ix. figs. 11-13. *P. compressa* (d'Orb.) Goës, 1894, K. Svenska

Vet.-Akad. Handl., vol. xxv. p. 58, pl. x. figs. 539-553. *P. compressa* (d'Orb.) Jones, 1895, Palæont. Soc., p. 258, pl. v. figs. 26, 28. *P. compressa* var. *marginalis* Jones and Chapman, 1896, Journ. Linn. Soc. (Zool.), vol. xxv. p. 507, fig. 37. *P. compressa* (d'Orb.) Flint, 1899, Rep. U.S. Nat. Mus. for 1897 (1899) p. 319, pl. lxvii. fig. 3. *P. proteus* (Beissel) Egger, 1899, Abhandl. k. bayer. Akad. Wiss., Cl. II. vol. xxi. p. 131, pl. xxv. figs. 16, 17.

Found sparingly at several Stations in both Areas. The examples are with difficulty separable from *P. amygdaloides*.

*Polymorphina elegantissima* Parker and Jones.

*Polymorphina elegantissima* Parker and Jones, 1864, Phil. Trans., vol. clv. table x. p. 438. *P. elegantissima* (P. and J.) Brady, Parker, and Jones, 1870, Trans. Linn. Soc., vol. xxvii. p. 231, pl. xl. fig. 15. *P. elegantissima* (P. and J.) Flint, 1899, Rep. U.S. Nat. Mus. for 1897 (1899), p. 319, pl. lxvii. fig. 4.

This form is tolerably abundant at Station 13 in Area 1, and occurs sparingly at Station 22 and a few others in Area 2. The examples are invariably small, and rarely consist of more than three chambers. Their affinity is with *P. problema*.

According to Brady,\* the species appears to be confined to the shores of the Pacific, and is best known from Australian specimens. Flint does not mention the locality of the 'Albatross' examples nor the depth from which they were obtained.

*Polymorphina communis* d'Orbigny.

*Polymorphina (Guttulina) communis* d'Orbigny, 1826, Ann. Sci. Nat., vol. vii. p. 266, pl. xii. figs. 1-4; Modèle, No. 62. *(Guttulina) problema* var. *deltoides* Andreae, 1884, Abhandl. geol. Special-Karte Elsass-Loth., vol. ii. p. 210, pl. ix. fig. 21. *P. glomerata* (Röm.) Beissel (Holzapfel) 1891, Abhandl. k. Preuss. geol. Landesanst., N.F. Heft 3, p. 62, pl. xii. figs. 17-29. *Bulimina pyrula* (d'Orb.) Silvestri, 1893, Atti e Rendic. Accad. Sci. Lett. e Arti dei Zelanti e P.P. dello Studio di Acireale, vol. v. p. 12, pl. v. figs. 73, 74. *Polymorphina gibba* near *communis* (d'Orb.) Goës, 1894, K. Svenska Vet.-Akad. Handl., vol. xxv. p. 55, pl. ix. figs. 523, 524. *P. communis* (d'Orb.) Jones, 1895, Palæont. Soc., p. 265, pl. v. fig. 24; pl. vi. fig. 16. *P. communis* (d'Orb.) var. *acuplacentia* Jones and Chapman, 1896, Journ. Linn. Soc. (Zool.) vol. xxv. p. 502, fig. 9. *P. communis* (d'Orb.) Burrows and Holland, 1897, Proc. Geol. Assoc., vol. xv. p. 46, pl. ii. fig. 14. *P. communis* (d'Orb.) Bagg, 1898, Bull. U.S. Geol. Survey, No. 88, p. 60, pl. vi. fig. 2.

\* Chall. Rept., 1884, p. 567.

*P. communis* var. *acuplacentia* (J. and C.) Silvestri, 1899, Mem. Pontif. Accad. Nuovi Lincei, vol. xv. p. 233, pl. iv. fig. 2. *P. communis* (d'Orb.) Flint, 1899, Rep. U.S. Nat. Mus. for 1897 (1899), p. 319, pl. lxxvii. fig. 6. *P. communis* (d'Orb.) Egger, 1899, Abhandl. k. bayer. Akad. Wiss., Cl. II. vol. xxi. p. 128, pl. xvii. figs. 36, 37. *P. communis* (d'Orb.) Fornasini, 1900, Mem. R. Accad. Sci. Ist. Bologna, ser. 5, vol. viii. p. 387, fig. 37.

Is not common nor widely distributed, but the examples are more robust than those of the other species of the genus found in the Malay Archipelago.

#### *Polymorphina problema* d'Orbigny.

*Polymorphina* (*Guttulina*) *problema* d'Orbigny, 1826, Ann. Sci. Nat., vol. vii. p. 266, No. 14; Modèle, No. 61. *Bulimina pyrula* (d'Orb.) Silvestri, 1893, Atti e Rendic. Accad. Sci. Lett. e Arti dei Zelanti e P.P. dello Studio di Acireale, vol. v. p. 12, pl. v. figs. 79, 80. *Polymorphina problema* (d'Orb.). Jones, 1895, Palæont. Soc. p. 267, pl. v. fig. 23; pl. vi. fig. 12. *P. problema* (d'Orb.) Burrows and Holland, 1897, Proc. Geol. Assoc., vol. xv. p. 46, pl. ii. fig. 17. *P. problema* (d'Orb.) Egger, 1899, Abhandl. k. bayer. Akad. Wiss., Cl. II. vol. xxi. p. 129, pl. xvii. figs. 33-35.

The specimens which can be distinguished from *P. communis* are few and insignificant, and seem to be confined to a few Stations in Area 1.

#### *Polymorphina oblonga* d'Orbigny.

*Polymorphina oblonga* d'Orbigny, 1846, For. Foss. Vienne, p. 232, pl. xii. figs. 29-31. *P. oblonga* (d'Orb.) Terquem, 1882, Mém. Soc. Géol. Fr., sér. 3, vol. ii. p. 145, pl. xxiii. fig. 9. *P. oblonga* (d'Orb.) Chaster, 1892, First Rept. of the Southport Soc. of Nat. Sci., 1890-1891 (1892), p. 64, pl. i. fig. 13. *P. oblonga* (d'Orb.) Egger, 1893, Abhandl. k. bayer. Akad. Wiss., Cl. II. vol. xviii. p. 309, pl. xi. figs. 9, 10, 24. *P. oblonga* (d'Orb.) Flint, 1899, Rep. U.S. Nat. Mus. for 1897 (1899) p. 319, pl. lxxvii. fig. 5.

This form is very rare in the Malay Archipelago and has been observed only at Station 22 in Area 2.

Of its occurrence in the recent condition, Brady states that its distribution is similar to that of the allied forms *P. problema* and *P. compressa*. Chaster records it from the neighbourhood of Southport. Egger's 'Gazelle' Stations are Table Bay, 50 fathoms; Mauritius, 225 fathoms; and West Australia, 196 fathoms. Flint records it from off the coast of Georgia and North Carolina, 276 and 168 fathoms.



*Polymorphina sororia* Reuss.

*Polymorphina (Guttulina) sororia* Reuss, 1863, Bull. Acad. Roy. Belg., sér. ii. vol. xv. p. 151, pl. ii. figs. 25-29. *P. sororia* (Reuss) Egger, 1893, Abhandl. k. bayer. Akad. Wiss., Cl. II. vol. xviii. p. 308, pl. ix. fig. 20. *P. sororia* (Reuss) Jones, 1896, Palæont. Soc., p. 257, pl. vi. fig. 13. *P. sororia* (Reuss) Chapman, 1896, Journ. R. Micr. Soc., p. 12, pl. ii. figs. 11, 12. *P. sororia* (Reuss) var. *fistulosa* Flint, 1899, Rep. U.S. Nat. Mus. for 1897 (1899), p. 319, pl. lxvii. fig. 2. *P. sororia* (Reuss) Egger, 1899, Abhandl. k. bayer. Akad. Wiss., Cl. II. vol. xxi. p. 126, pl. xvii. figs. 6, 7.

Although moderately plentiful and widely distributed in the Malay Archipelago, the examples are small and composed of but few chambers.

Brady says of this form that it is less common than the type (*P. lactea*), but it has a similar wide area of distribution. Egger records it from West Africa, 371 fathoms; and Flint has the fistulose variety from the North Atlantic, from off the coast of Brazil, and from the Gulf of Mexico, 671 to 1781 fathoms.

*Polymorphina sororia* var. *cuspidata* Brady.

*Polymorphina sororia* var. *cuspidata* Brady, 1884, Chall. Rept., p. 563, pl. lxxi. figs. 17-19, pl. lxxii. fig. 4. *P. sororia* var. *cuspidata* (Brady) Chapman, 1896, Journ. R. Micr. Soc., p. 13, pl. ii. fig. 13. *P. sororia* var. *cuspidata* (Brady) Egger, 1899, Abhandl. k. bayer. Akad. Wiss., Cl. II. vol. xxi. p. 127, pl. xvii. figs. 10, 11.

This variety is better represented than the type, it is rather more abundant, and widely distributed, and the examples are less feeble.

Brady says, "This form has been met with at two points in the North Atlantic, west of Ireland, depth 808 fathoms and 1443 fathoms respectively; and at Station 146, about midway between the Cape of Good Hope and Kerguelen Island, 1375 fathoms."

*Polymorphina regina* Brady, Parker, and Jones.

*Polymorphina regina* Brady, Parker, and Jones, 1870, Trans. Linn. Soc., vol. xxvii. p. 241, pl. xli. fig. 32; and *P. Orbignii* (Zborzewski sp.) p. 244, pl. xlii. fig. 38m. *P. semicostata* Marsson, 1878, Mitth. Nat. Ver. Neu-Vorpommern u. Rugen, Jahrg. x. p. 150, pl. ii. fig. 19. *P. regina* (B., P., and J.) var. Wright, 1886, Proc. Belfast Nat. Field Club, 1884-1885, App. ix. p. 331, pl. xxvii. figs. 13, 14. *P. regina* (P. and J.) Egger, 1893, Abhandl. k. bayer. Akad. Wiss., Cl. II. vol. xviii. p. 310, pl. ix. figs. 45, 50, 51. *P. regina* var. *damæcornis* (Reuss) Jones and Chapman, 1896, Journ.

Linn. Soc. (Zool.), vol. xxv. p. 501, fig. 3; and var. *marginalis*, p. 507, fig. 36.

This form is represented by a few examples from Station 22 in Area 2. The shell is very thin and there are rarely more than two chambers.

Of its distribution in the recent condition Brady writes,\* "The distribution of *Polymorphina regina* seems limited to comparatively shallow water in the neighbourhood of the islands of the Pacific."

Egger records it from Kerguelen Island, 57 fathoms.

*Dimorphina* d'Orbigny.

*Dimorphina lingulinoides* sp. n., plate V. fig. 6.

Test elongate, straight, compressed; extremities rounded or obtuse; earlier portion biserial, with triangular chambers; sutures sinuous, not depressed; final portion Linguline; aperture a long slit, with protruding lips. Length 0.33 mm.

This form closely resembles the *D. compacta* of the Coralline Crag of Sutton, but is easily distinguished from it by the slit-like aperture.

In the tertiary beds of St. Erth *Dimorphinae* are not uncommon, but all the forms are compounded of the genera *Polymorphina* and *Lingulina*, thus differing from all the described species with the exception of *Polymorphina regularis* var. *parallela* † of the St. Erth clay, which evidently belongs to this group. In *Dimorphina Capellini*, ‡ from the lower pliocene of Bonfornello in Sicily, the aperture is a lipped slit, but it is slightly curved, and the chamber to which it pertains is circular in transverse section.

In the Malay Archipelago *D. lingulinoides* is very rare and has been noticed only at Station 25 in Area 2.

*Uvigerina* d'Orbigny.

*Uvigerina canariensis* d'Orbigny, plate V. fig. 7.

*Uvigerina canariensis* d'Orbigny, 1839, Foram. Canaries, p. 138, pl. i. figs. 25-27. *U. canariensis* (d'Orb.) Fornasini, 1891, Foraminiferi Pliocenici del Ponticello di Savena, pl. ii. fig. 26. *U. canariensis* (d'Orb.), Woodward and Thomas, 1893, Geol. and Nat. Hist. Survey of Minnesota, vol. iii. p. 39, pl. D, fig. 9. *U. canariensis* (d'Orb.) Egger, 1893, Abhandl. k. bayer. Akad. Wiss., Cl. II. vol. xviii. p. 311, pl. ix. fig. 43. *U. canariensis* (d'Orb.) Goës, 1894,

\* Chall. Rept., 1884, p. 571.

† Mill. et al., Trans. R. Geol. Soc. of Cornwall, vol. xi. 1895, p. 658, pl. figs. 5, 6.

‡ De Amicis. Naturalista Siciliano, anno xiv. 1895, p. 45, pl. i. fig. 18.

K. Svenska Vet.-Akad. Handl., vol. xxv. p. 52, pl. xi. figs. 489-492. *U. canariensis* (d'Orb.) forma *distoma* De Amicis, 1894, Atti Soc. Tosc. Sci. Nat., Mem., vol. xiv. p. 29, pl. ii. fig. 5. *U. canariensis* (d'Orb.) var. *farinosa* (Hantken) Jones, 1896, Palæont. Soc., p. 278, pl. vii. fig. 27.

This form is very abundant and occurs at nearly all the Stations in both Areas. The surface of the test, normally smooth, is often more or less rough, and without a break passes into that of *U. aculeata*.

The typical form is common, but the specimen chosen for illustration represents an interesting variety which occurs only at Station 22 in Area 2.

*Uvigerina asperula* Czjzek.

*Uvigerina asperula* Czjzek, 1848, Haidinger's Naturwiss. Abhandl., vol. ii. p. 146, pl. xiii. figs. 14, 15. *U. asperula* (Czjzek) Sherborn and Chapman, 1886, Journ. R. Micr. Soc., ser. 2, vol. vi. p. 755, pl. xvi. fig. 7. *U. asperula* (Czjzek) Toutkowsky, 1887, Zap. Kievsk. Obsch. Estest., vol. ix. p. 41, pl. ii. fig. 3. *U. asperula* (Czjzek). Brady, Parker, and Jones, 1888, Trans. Zool. Soc., vol. xii. p. 225, pl. xlv. figs. 4, 5. *U. asperula* (Czjzek) Terrigi, 1891, Mem. R. Com. Geol. Italia, vol. iv. p. 100, pl. iii. fig. 25. *U. asperula* (Czjzek) Egger, 1893, Abhandl. k. bayer. Akad. Wiss., Cl. II. vol. xviii. p. 312, pl. ix. fig. 41. *U. asperula* (Czjzek) Flint, 1899, Rep. U.S. Nat. Mus. for 1897 (1899), p. 320, pl. lxviii. fig. 4.

This is just as plentiful as the smooth form, *U. canariensis*, and the distribution is identical. It may be noted that at the individual Stations the relative abundance of the two forms is invariably the same.

The disposition to become uniserial is shown in many examples, and in this respect they resemble the var. *ampullacea* of Brady, which is described as a dimorphous *U. asperula*, connecting the *Uvigerinæ* with the *Sagrinæ*.

*Uvigerina asperula* Czjzek var. *ampullacea* Brady.

*Uvigerina asperula* (Czjzek) var. *ampullacea* Brady, 1884, Chall. Rept., p. 579, pl. lxxv. figs. 10, 11. *U. ampullacea* (Brady) Egger, 1893, Abhandl. k. bayer. Akad. Wiss., Cl. II. vol. xviii. p. 313, pl. ix. fig. 37. *U. asperula* var. *ampullacea* (Brady) Flint, 1899, Rep. U.S. Nat. Mus. for 1897 (1899), p. 320, pl. lxviii. fig. 5.

In the Malay Archipelago this variety of *U. asperula* is very rare, and is confined to Area 1.

Brady names nine localities where it has been found, the depths ranging from 350 fathoms to 725 fathoms; Egger records it from

Mauritius, 225 fathoms, and from West Australia, 560 fathoms; whilst the only 'Albatross' Station is off the Brazil coast, 1019 fathoms.

*Uvigerina interrupta* Brady.

*Uvigerina interrupta*, Brady, 1879, Quart. Journ. Micr. Sci., n.s. vol. xix. p. 274, pl. viii. figs. 17, 18. *U. interrupta* Brady, 1884, Chall. Rept., p. 580, pl. lxxv. figs. 12-14. *U. interrupta* (Brady) Egger, 1893, Abhandl. k. bayer. Akad. Wiss., Cl. II. vol. xviii. p. 313, pl. ix. fig. 58.

This appears to be nothing more than an attenuated form of *U. ampullacea*, and the gradation from one to the other is well shown by the Malay specimens.

It is plentiful at Station 25 in Area 2, and occurs, but very sparingly, at a few Stations in Area 1.

Brady says it has only been observed in the South Pacific, and names six localities, the depths varying from 37 to 1375 fathoms.

Egger gives two 'Gazelle' Stations, both off the coast of West Australia, at depths of 196 and 650 fathoms.

*Uvigerina auberiana* d'Orbigny var. *glabra* var. n.,  
pl. V. figs. 8, 9.

*Uvigerina auberiana* d'Orbigny, 1839, Foram. Cuba, p. 106, pl. ii. figs. 23, 24. *U. auberiana* (d'Orb.) Goës, 1882, K. Svenska Vet.-Akad. Handl., vol. xix. p. 60, pl. iv. figs. 71-75.

The Malay examples of this form are more compressed and neater than those from the West Indies described by d'Orbigny; they also differ in having the surface of the test quite smooth, but they agree in the more important character of being biserial. The elongated form (fig. 9) differs from *Bolivina* only in the form of the aperture. It closely resembles the figures of *U. Parkeri* given by Karrer,\* but he does not state that his species is biserial. Brady in his 'Challenger' Report makes *U. auberiana* a variety of *U. asperula*; if this diagnosis were accepted the Malay form would have to be treated as a compressed biserial variety of *U. canariensis*, but taking surface ornamentation as being of less value than the mode of aggregation of the chambers, it seems more natural to group together the biserial varieties.

Goës, writing of *U. auberiana* from the Caribbean Sea, says, "Our form is often more smooth and more slender than d'Orbigny's—also from the West Indies." These, it will be observed, are pre-

\* Abhandl. k. k. geol. Reichs., vol. ix. 1877, p. 385.

cisely the differences between d'Orbigny's and the Malay examples.

The smooth form is very abundant in the Malay Archipelago and occurs at most of the Stations in both Areas.

*Uvigerina pygmaea* d'Orbigny.

*Uvigerina pygmaea* d'Orbigny, 1826, Ann. Sci. Nat., vol. vii. p. 269, pl. xii. figs. 8, 9; and Modèle, No. 67. *U. pygmaea* (d'Orb.), Brady, Parker, and Jones, 1888, Trans. Zool. Soc., vol. xii. p. 224, pl. xlv. figs. 1, 2. *U. pygmaea* (d'Orb.) Terrigi, 1891, Mem. R. Com. Geol. Italia, vol. iv. p. 100, pl. iii. fig. 24. *U. pygmaea* (d'Orb.) Egger, 1893, Abhandl. k. bayer. Akad. Wiss., Cl. II. vol. xviii. p. 314, pl. ix. fig. 42. *Polymorphina regina* (B., P., and J.) Silvestri, 1893, Atti e Rendic. Accad. Sci. Lett. e Arti dei Zelanti e P.P. dello Studio di Acireale, vol. v. p. 14, pl. v. figs. 70-72. *U. pygmaea* (d'Orb.) Silvestri, 1893, Mem. Pontif. Accad. Nuovi Lincei, vol. ix. p. 207, pl. v. fig. 5. *U. pygmaea* (d'Orb.) Goës, 1894, K. Svenska Vet.-Akad. Handl., vol. xxv. p. 51, pl. ix. figs. 496-501. *U. pygmaea* (d'Orb.) Flint, 1899, Rep. U.S. Nat. Mus. for 1897 (1899), p. 320, pl. lxviii. fig. 2. *U. pygmaea* (d'Orb.) Silvestri, 1899, Mem. Pontif. Accad. Nuovi Lincei, vol. xv. p. 239, pl. iv. fig. 5; and *U. pygmaea* var. *asperula* Idem, 1900, Ibid. vol. xvii. p. 277, pl. vi. fig. 95.

This form is represented by a few feeble examples from Station 2, in Area 1.

*Uvigerina porrecta* Brady.

*Uvigerina porrecta* Brady, 1879, Quart. Journ. Micr. Sci., n.s. vol. xix. p. 274, pl. viii. figs. 15, 16; Idem, 1884, Chall. Rept., p. 577, pl. lxxiv. figs. 21-23. *U. porrecta* (Brady) Egger, 1893, Abhandl. k. bayer. Akad. Wiss., Cl. II. vol. xviii. p. 315, pl. ix. figs. 51, 63.

This form also is very rare in the Malay Archipelago, although it occurs at Stations in both Areas.

With regard to its distribution generally, Brady writes, "This is a coral-reef species, and with one exception all the localities lie within the tropics." He names several Stations where it has occurred at depths ranging from 12 fathoms to 1850 fathoms. The solitary 'Gazelle' Station is West Australia, 196 fathoms.

*Uvigerina angulosa* Williamson.

*Uvigerina angulosa* Williamson, 1858, Rec. Foram. Gt. Britain p. 67, pl. v. fig. 140. *U. angulosa* (Will.) Egger, 1893, Abhandl. k. bayer. Akad. Wiss., Cl. II. vol. xviii. p. 314, pl. ix. figs. 40, 46, 47.

June 17th, 1903

T

*U. angulosa* (Will.) Goës, 1894, K. Svenska Vet.-Akad. Handl., vol. xxv. p. 51, pl. ix. figs. 502-509. *U. angulosa* (Will.) Jones, 1895, Palaeont. Soc., p. 277, pl. vii. fig. 26. *U. angulosa* (Will.) Flint, 1899, Rep. U.S. Nat. Mus. for 1897 (1899), p. 320, pl. lxviii. fig. 3. *U. angulosa* (Will.) Liebus, 1901, Neues Jahrb. für Min., vol. i. p. 120, pl. v. fig. 3.

This species is likewise rare in the Malay Archipelago, but it is found in both Areas, and the examples are well developed.

*Sagrina* d'Orbigny, emended by Parker and Jones.

*Sagrina columellaris* Brady, plate V. figs. 10, 11.

*Sagrina columellaris* Brady, 1881, Quart. Journ. Micr. Sci., n.s. vol. xxi. p. 64. *Siphogenerina glabra* Schlumberger, 1883, Feuille Jeunes Nat., p. 118, pl. iii. fig. 1. *Siphogenerina (Sagrina) columellaris* (Brady) Egger, 1893, Abhandl. k. bayer. Akad. Wiss., Cl. II. vol. xviii. p. 316, pl. ix. figs. 28, 31, 33. *Siphogenerina columellaris* (Brady) Idem, 1899, Ibid., vol. xxi. p. 134, pl. xvi. figs. 20, 21. *Sagrina columellaris* (Brady) Fornasini, 1900, Mem. R. Accad. Sci. Ist. Bologna, ser. 5, vol. viii. p. 391, fig. 41. *Siphogenerina columellaris* (Brady) Silvestri, 1902, Atti Pontif. Accad. Romana dei Nuovi Lincei, anno lv. p. 1, figs. 1, 2.

In treating of *Bigenerina (Siphogenerina) Schlumbergerii* mention was made of the difficulty of assigning to the various forms of *Siphogenerina* their correct position in the classification of the foraminifera; whether *columellaris* would be more at home amongst the *Sagrinae* or the *Bigenerinae*, is still a matter of opinion.

The recent discovery by Prof. Silvestri\* of characteristic specimens of *Pleurostomella brevis* having the contorted internal tube, is of great interest in its bearing on this question.

In the Malay Archipelago the number of examples is small and the species seems to be confined to Area 1. There are, however, specimens of both the microspheric and megalospheric forms, which are well differentiated in this species, as shown by the figures given by Schlumberger in 1883, and by Silvestri in 1902.

With regard to its general distribution in the living condition, Brady in his 'Challenger' Report gives thirteen localities, at depths varying from the shore to 1125 fathoms; Egger quotes three 'Gazelle' Stations, at depths from 75 fathoms to 225 fathoms; whilst Fornasini and Silvestri record it from the Adriatic and Mare Jonio.

*Sagrina bifrons* Brady.

*Sagrina bifrons* Brady, 1881, Quart. Journ. Micr. Sci., n.s. vol. xxi. p. 64; and 1884, Chall. Rept., p. 582, pl. lxxv. figs. 18-20.

\* Atti R. Accad. Sci. Torino, vol. xxxviii. 1903, p. 5, fig. 1a-c.

*Siphogenerina (Sagrina) bifrons* (Brady) Egger, 1893, Abhandl. k. bayer. Akad. Wiss., Cl. II. vol. xviii. p. 317, pl. ix. figs. 25, 26, 29. *Sagrina bifrons* (Brady) Idem, 1899, Ibid., vol. xxi. p. 134, pl. xv. figs. 25, 26.

Of this rare form a few poor examples occur at several Stations in both Areas; they differ from *columellaris* in little more than the compression of the test.

Brady states that it has only been observed in one locality, the *Hyalonema*-ground, south of Japan, depth 345 fathoms. Egger's very doubtful 'Gazelle' examples are from West Australia, 560 fathoms.

*Sagrina virgula* Brady.

*Sagrina virgula* Brady, 1879, Quart. Journ. Micr. Sci., n.s. vol. xix. p. 275, pl. viii. figs. 19-21; and 1884, Chall. Rept., p. 583, pl. lxxvi. figs. 4-10. *Siphogenerina (Sagrina) virgula* (Brady) Egger, 1893, Abhandl. k. bayer. Akad. Wiss., Cl. II. vol. xviii. p. 318, pl. ix. fig. 27.

In the Malay Archipelago this is the predominant species of the genus, being found in abundance at most of the Stations all over the Region. The examples are large, well developed, and possess all the characters of the species.

With regard to its distribution elsewhere, Brady writes, "*Sagrina virgula* has been obtained in the South Atlantic off Pernambuco, 675 fathoms; with that exception the distribution, which extends altogether to ten localities, is confined to the South Pacific, the bathymetrical range being from 12 fathoms to 2075 fathoms." Egger reports it from the western coast of South Africa, 1914 fathoms; and two Stations off West Australia, 196 fathoms and 560 fathoms.

*Sagrina nodosa* Parker and Jones, plate V. figs. 12-15.

*Uvigerina (Sagrina) nodosa* Parker and Jones, 1865, Phil. Trans., vol. clv. p. 363, pl. xviii. fig. 15. *Sagrina nodosa* (P. and J.) Brady, 1884, Chall. Rept., p. 583, pl. cxiv. fig. 18. *S. cylindrica* (d'Orb. sp.) Fornasini, 1897, Rivista Ital. di Paleont., fasc. v. vi. p. 13, fig.

As indicated by the figures, the Malay Archipelago representatives of this species vary considerably from the type. The uniserial chambers are often irregularly lobed at their base; whilst in some examples the Uvigerine portion is obscure, and the test appears to be uniserial throughout. In the surface ornamentation the usual costæ are replaced by regular rows of closely placed dots; a few of the examples, however, have the surface quite smooth. In my cabinet are examples dredged from 50 fathoms off the coast of

Portugal which resemble the Malay forms in every respect. It may be noted that in some of Terquem's figures of *Uvigerina muralis* from the Paris cocene,\* there is an evident tendency to the lobulation of the base of the chambers.

*S. nodosa* is not uncommon in the Malay Archipelago and occurs at several Stations in both Areas.

Brady in his 'Challenger' report writes "*Sagrina nodosa* is by no means a common form: so far as the 'Challenger' collections are concerned, it only appears at one locality,—off the Cape of Good Hope, depth 150 fathoms. Otherwise it has been reported from the Mediterranean and from the Italian tertiaries."

*Sagrina striata* Schwager sp.

*Dimorphina striata* Schwager, 1866, Novara-Exped., Geol. Theil, vol. ii. p. 251, pl. vii. fig. 99, and fig. 2 in text. *Sagrina striata* Schwager, 1877, Boll. R. Com. Geol. Italia, p. 25, pl. fig. 35. *S. striata* (Schwager) Brady, 1884, Chall. Rept., p. 524, pl. lxxv. figs. 25, 26. *Siphogenerina (Sagrina) striata* (Brady) Egger, 1893, Abhandl. k. bayer. Akad. Wiss., Cl. II. vol. xviii. p. 316, pl. ix. figs. 32, 34, 35, 64, 65.

Usually this is not a common form, but in the Malay Archipelago it is well represented, being found in considerable numbers at several Stations in both Areas. The examples are fine and exhibit greater affinity with *S. raphanus* than with *S. nodosa*.

Brady specifies the following localities:—"Off the coast of South America, south of Pernambuco, 350 fathoms; shore-sand, east coast of Madagascar; off Kandavu, Fiji Islands, 210 fathoms; off New Hebrides, 125 fathoms; Torres Strait, 3 to 11 fathoms; off Ki Islands, 129 fathoms; and off the Philippines, 95 fathoms." The 'Gazelle' Stations are Mauritius, 225 fathoms, and West Australia, 196 fathoms.

*Sagrina raphanus* Parker and Jones.

*Uvigerina (Sagrina) raphanus* Parker and Jones, 1865, Phil. Trans., vol. clv. p. 363, pl. xviii. figs. 16, 17. *Siphogenerina costata* Schlumberger, 1883, Feuille Jeunes Nat., p. 118, fig. B. *Sagrina raphanus* (P. and J.) Brady, 1884, Chall. Rept., p. 585, pl. lxxv. figs. 21-25. *Siphogenerina (Sagrina) raphanus* (P. and J.) Egger, 1893, Abhandl. k. bayer. Akad. Wiss., Cl. II. vol. xviii. p. 317, pl. ix. fig. 36.

Although not quite so abundant in the Malay Archipelago as *S. striata*, nor so widely distributed, the examples are fine and characteristic, and both the microspheric and megalospheric forms are represented.

\* Mém. Soc. Géol. Fr., sér. 3, vol. ii. 1882, p. 119, pl. xx. figs. 26-29.



Brady writes, "*Sagrina raphanus* is essentially a coral-reef Foraminifer," and then specifies a number of Stations, the depths ranging from 2 to 260 fathoms. The solitary 'Gazelle' example is from Mauritius, 225 fathoms.

*Sagrina tessellata* Brady, plate V. fig. 16.

*Sagrina* (?) *tessellata* Brady, 1884, Chall. Rept., p. 585, pl. lxxvi. figs. 17-19.

Of this very rare and doubtful form several examples have been found in the material from Station 2, in Area 1. Externally they agree in all respects with the figures of the 'Challenger' specimens; but internally the chambers are subdivided into chamberlets by transverse septa, usually from eight to ten in each chamber.

According to Brady his knowledge of the species was derived from two or three specimens from Nares Harbour, Admiralty Islands, 17 fathoms, and Raine Island, Torres Strait, 155 fathoms.

*Sagrina limbata* Brady, plate V. figs. 17-19.

*Sagrina limbata* Brady, 1884, Chall. Rept., p. 586, pl. cxiii. fig. 14. *S. limbata* (Brady) Howchin, 1889, Trans. R. Soc. S. Australia, vol. xii. p. 11, pl. i. fig. 7.

Of this very rare and little understood form a solitary example has been found in the material from Station 2, in Area 1. Unfortunately the specimen has been mislaid, but the finder, Charles Elcock of Belfast, had previously made a drawing of it, and a copy of this appears on the plate (fig. 17).

Brady's diagnosis of the species was made from ill-grown examples, and is necessarily imperfect. Having myself been especially fortunate in finding examples in the material from Raine Island, kindly sent me by Sir John Murray of the 'Challenger' office, I am in a position to add to Brady's description. Essentially the test is composed of a series of elongate-oval chambers, usually four in number, as shown by fig. 18; these chambers, as in *S. tessellata*, are subdivided into chamberlets by transverse septa which are well shown in the abraded specimen, fig. 19. Brady was unaware of these characters until he had examined my specimens shortly after the publication of the 'Challenger' Report on the Foraminifera, and his figure does not represent them. Howchin's drawing represents a much more characteristic example and indicates the division of the test into chambers. In several specimens the initial chamber is broad at the base, and obliquely truncated as shown in fig. 18.

The division of the chambers by transverse septa is not a character of the genus *Sagrina*, and further researches will prob-

ably render it necessary to constitute a new genus embracing the species *tessellata*, *limbata*, and probably *annulata*.

With regard to its hitherto recorded distribution, Brady writes, "*Sagrina limbata* has only been encountered at a single locality,—off Raine Island, Torres Strait, depth 155 fathoms."

Howchin writes, "A single specimen of this very rare form was obtained from the Lower-Bed. The test is longer and more slender than Mr. Brady's figure and is also more curved in outline, but in all essential features agrees with the type." The "Lower-Bed," mentioned above, is a portion of the Older Tertiary of Muddy Creek, Victoria, Australia.

### Sub-family **Ramulininæ.**

#### *Ramulina* Rupert Jones.

#### *Ramulina laevis* Jones.

*Ramulina laevis* (Jones) Wright, 1875, Proc. Belfast Nat. Field Club, 1873-1874, App. iii. p. 88, pl. iii. fig. 19; and *R. brachiata* (Jones), p. 88, pl. iii. fig. 20. *Ramulina* sp., Balkwill and Millett, 1884, Journ. Micr., vol. iii. p. 83, pl. iv. fig. 7. *R. Bradyi* Rzehak, 1895, Ann. k. k. Naturh. Hofmuseums, vol. x. p. 223, pl. vi. fig. 5; and *R. exigua*, p. 223, pl. vi. fig. 4. *R. laevis* (Jones) Chapman, 1896, Journ. R. Micr. Soc., p. 582, pl. xii. fig. 2; and 1898, p. 2, pl. ii. fig. 15. *R. laevis* (Jones) Jones and Chapman, 1897, Journ. Linn. Soc. (Zool.), vol. xxvi. p. 339, figs. 1-4. *R. proteiformis* Flint, 1899, Rep. U.S. Nat. Mus. for 1897 (1899), p. 321, pl. lxxviii. fig. 7. *R. laevis* (Jones) Schubert, 1901, Zeitschr. deutsch. geol. Gesell., Jahrg. 1901, p. 19, fig. 1.

This smooth variety of *Ramulina* is represented by a few fragments from Station 13, in Area 1.

It is much more abundant as a fossil than as a recent form.

#### *Ramulina globulifera* Brady.

*Ramulina globulifera* Brady, 1879, Quart. Journ. Micr. Sci., n.s. vol. xix. p. 272, pl. viii. figs. 32, 33; and 1884, Chall. Rept., p. 587, pl. lxxvi. figs. 22-28. *Tinoporos baculatus* Sherborn and Chapman, 1886, Journ. R. Micr. Soc., ser. ii. vol. vi. p. 758, pl. xvi. fig. 24. *Lagena laevis* (Montagu) Terrigi, 1899, Mem. R. Accad. Lincei, ser. 4, vol. vi. p. 112, pl. vi. figs. 2, 3. *Lagena protea* Chaster, 1892, First Rept. of the Southport Soc. of Nat. Sci., 1890-1891 (1892), p. 62, pl. i. fig. 14. *Ramulina globulifera* (Brady) Egger, 1893, Abhandl. k. bayer. Akad. Wiss., Cl. II. vol. xviii. p. 310, pl. ix. fig. 62. *R. globulifera* (Brady) De Amicis, 1895, Naturalista Siciliano, anno xiv. p. 112, pl. i. fig. 14. *R. globulifera* (Brady) Chapman, 1896, Journ.

R. Micr. Soc., p. 582, pl. xii. figs. 3-6. *R. globulifera* (Brady) Jones and Chapman, 1897, Journ. Linn. Soc. (Zool.), vol. xxvi. p. 340, figs. 5-22. *R. globulifera* (Brady) Egger, 1899, Abhandl. k. bayer. Akad. Wiss., Cl. II. vol. xxi. p. 135, pl. ii. fig. 2; and pl. xxii. fig. 33. *R. globulifera* (Brady) Flint, 1899, Rep. U.S. Nat. Mus. for 1897 (1899), p. 321, pl. lxxviii. fig. 6.

This fragile form is well represented in the Malay Archipelago, and occurs in more or less abundance at many Stations in both Areas.

Brady and other authorities record the species from numerous localities widely apart, but it appears to be most at home in the South Pacific.

V.—*A New Method of Using the Electric Arc in Photomicrography.*

By E. B. STRINGER, B.A. F.R.M.S.

*(Read April 17th, 1903.)*

THE method I have adopted consists, briefly, in employing the radiation from the electric arc itself, altogether separated from that of the incandescent carbons. This, modified by certain light-filters, yields a powerful violet monochromatic light, on the extreme limit of visibility.

If an image of the arc formed by condensers of good white glass be thrown upon an opening in a blackened screen, the opening being of such a size as to allow only the radiation from the arc to pass, the separation is easily effected. The light thus obtained is of a warm violet colour, and very rich in ultra-violet rays, as is shown by its great power of exciting fluorescence in such bodies as solutions of quinine and *æsculin* and in the *platinocyanides*. Its spectrum, examined with an instrument of fairly high dispersive power, is a fluted one, especially remarkable for a bright group of lines in the blue, and a band, still brighter, in the extreme violet, which is separated from the rest of the spectrum by a dark interval of some length. If now a solution of *ammonia-sulphate* of copper be interposed of such a strength as only to transmit the violet band, and if the ultra-violet rays be cut off by another trough containing a solution of sulphate of quinine, we obtain the light I have described.

The six lines of which the violet band is made up are close together and differ only very slightly in wave-length, so that the light may be considered strictly monochromatic; and though visually of little intensity its actinic power is great, and at 2000 diameters the necessary exposure is only 15 seconds. There is, moreover, light enough to focus by with ease at this magnification.

The apparatus which I described in the *Society's Journal* of April 1898 proves to be well adapted for the work. The condensers are aplanatic, and of the purest white Jena glass, and throw a sharp magnified image of the arc upon the substage diaphragm: and as this image is formed by a pencil of slightly divergent rays, the working of the substage condenser is in no way interfered with.

A shutter having pneumatic release is attached to the camera front. Then, with one hand on the feeding adjustment of the arc lamp and the other holding the pneumatic ball, the image of the arc is easily watched upon the substage diaphragm, and the exposure made at the right moment.

In order that the arc may be perfectly steady the carbons should be small; solid ones of 6 mm. diameter are the best to use, and the purer the better: the purest I have yet tried are those known as Noris carbons. The arc must, of course, be a comparatively long one, about  $\frac{1}{4}$  in., to which end the voltage should be high, not less than 100; and a hand-fed lamp such as Davenport's will be found much the best. It is also absolutely necessary to protect the arc from air currents by enclosing it in a lantern body, and the current used should not be less than 6 amperes.

It may be added that the method has also the advantage of completely doing away with the excessive light and heat which proceed from the positive carbon. The light is very apt to cause flare in spite of every precaution, and the heat is liable to damage balsam and styrax mounts even through the 6 in. of water which the trough contains. With the arc alone there is danger of neither of these things.

The two lantern slides are of *Pleurosigma angulatum* dry, and *Coccioidiscus asteromphalus* in styrax, taken by the above method with Zeiss' 3 mm. oil apochromatic objective N.A. 1.4 and 8 compensating eye-piece, the full aplanatic cone from Powell's dry apochromatic condenser, and a camera length of 32 in.; giving a magnification of 2200 diameters. The exposures were 15 and 20 seconds respectively, the current used by the lamp being 6 amperes.

The arc light is, of course, known to be very rich in ultra-violet rays. But, if an image of the arc, formed by condensers of pure white glass, be received upon a fluorescent screen (one of those used in Röntgen ray work, of barium platino-cyanide, is the most convenient) it will be seen that the ultra-violet rays proceed to a very large extent, if not entirely, from the arc itself. The arc is seen to consist of a central core, surrounded by a kind of lambent flame; and it is from this central core that the ultra-violet rays proceed, as is evident from the powerful excitation of the fluorescent substance. The central core evidently consists of incandescent carbon vapour, whilst the surrounding flame is due to the combustion of the carbons in the air.

If the spectrum of the arc be projected by means of a prism of good white glass upon the fluorescent screen, it will be seen to be very much prolonged into the ultra-violet region, principally in two broad bands which appear a bright green. Even on a screen of ordinary card these bands may be seen in a carefully darkened room, as the pale lavender grey described by Herschel; and when a trough containing a solution of quinine is held in front of the slit, they are completely cut off.

But it appears quite possible that these ultra-violet rays, which we are at present obliged to cut off because our lenses are not corrected for them, may one day be brought into use, and may

enable photography to do for the Microscope what it has already done for the telescope, and reveal detail beyond the range of vision; and this is the more feasible since in the arc we possess, as I have shown, a powerful and easily controlled source of them.

It is stated by Stokes that the ultra-violet spectrum of the arc light is with quartz lenses and prisms six times as long as the visible spectrum; and all of this can be photographed. With glass prisms it is not of course so long, nor so intense; and for microscopical purposes it is chiefly glass which we must consider. But, according to Abney, much more may be done with glass than is generally supposed, and "with pure white flint-glass prisms the furthest lines in the solar spectrum can be photographed." This was done by Cornu, using crown and flint-glass prisms, as far as the Fraunhofer line U. The wave-length of this line in ten-millionths of a millimetre by Cornu's map is 2948, that of  $D_1$ , the line of maximum visibility, being 5889. The wave-length of U is, therefore, almost exactly one-half that of D, and should give twice the resolution. But Cornu, as stated above, used prisms and lenses of crown and flint. The arc light moreover extends a great deal further into the ultra-violet than does sunlight, so that by the proper choice of glasses (of which so many are now available) and of other media, much more might be done. Fluorite is fortunately very transparent to these rays, as much so, according to Miller's tables, as quartz. If opticians could thus provide us with lenses transmitting rays far into the ultra-violet, and at the same time fully corrected for them, we might hope to achieve a considerable advance.

I find that a lens of the kind suggested was actually made by Rutherford for the telescope which he used in stellar photography. "Mr. Rutherford," says Lockyer, "simply discards the visual rays, and brings together the violet ones; the result of his work being a telescope through which it is impossible to see anything, but through which the minutest star down to the tenth magnitude can be photographed with the most perfect sharpness. This is the instrument of the future, so far as stellar photography is concerned."

The two kinds of work are not of course quite analogous. The additional detail is brought out in telescopic work mainly by prolonged exposure, and Rutherford did not apparently take the ultra-violet into consideration; yet one may venture to predict that the photographic objective of the future will be something of the same kind.

The difficulty of constructing such an objective would no doubt be great, and its use when constructed would be far from easy, especially in focussing; but this might not be so difficult if it were corrected so as to bring the visible violet to the same focal point as the ultra-violet, since the focussing on the coarser detail might

then be effected visually by means of the former, leaving the finer detail to be resolved photographically by the shorter waves. Much assistance might also be got by the use of a fluorescent screen, though I have hitherto tried this method without much success. A transparent fluorescent screen such as is used in spectroscopic work must be inclined to the optic axis, and a focussing screen, by the nature of the case, cannot be so inclined. I have also tried an opaque fluorescent screen, the platinocyanide one, observing the image upon its surface through the door in the side of the camera; but it is exceedingly difficult to see fine detail in this way, though the screen becomes strongly fluorescent, and the decided grain of the screen is also a hindrance.

Such experiments can, however, be only very imperfectly made with the lenses which are at present available; though the fact that the screen does become fluorescent, proves that they transmit the invisible rays to a considerable degree. This is also evident from the fact that they give a badly defined photographic image without the quinine solution; and that if the ammonia-copper solution (which is partly opaque to the most refrangible rays transmitted by glass) be also removed, the definition is still more imperfect.

This is shown in the three photographs of *Navicula Bombus*.

(A) is with the light from the arc, the ammonia-copper and quinine solutions being both used.

(B) is the same without the quinine solution.

(C) is the same without either the copper or quinine.

The images in all of them were focused visually with equal sharpness.

I find that Stokes used in his investigations a fluorescent screen of uranium phosphate, which might prove to be better than barium platinocyanide for the present purpose. By means of it he discovered that solutions of the vegetable alkaloids exercise a powerful selective absorption in the ultra-violet; so that by a suitable choice of these it might be possible to make the ultra-violet rays also "monochromatic"; especially as the banded character of the arc spectrum is no doubt continued throughout that region. All this might some day be done. But the difficulties to be overcome are so many that I confess I submit these considerations to the Society with a good deal of diffidence, having much doubt as to whether they will ever prove to be of any practical value.

---

I have since found that the Microscope (and the same lenses with which the photographs were done) transmits both ultra-violet bands, having succeeded in projecting them upon the fluorescent screen by means of a slit, lens, and prism, placed beyond the eye-piece. The second or more refrangible one, however, appears

rather diminished in intensity. I also find that styrax, in which the *Naricula* was mounted, is completely opaque to the second band, whilst balsam transmits it quite undimmed. The defective definition would, therefore, be much greater with a balsam mount. Monobromide of naphthalin is perfectly transparent to both bands, so is cedar oil; but realgar is unfortunately opaque to both, and to the visible violet as well. The silica of diatoms is, of course, very transparent to all the ultra-violet rays.

A solution of methylen-blue is much more transparent to the second band than the ammonia-copper, but has the disadvantage of also transmitting the red.



SUMMARY OF CURRENT RESEARCHES  
RELATING TO  
ZOOLOGY AND BOTANY  
(PRINCIPALLY INVERTEBRATA AND CRYPTOGRAMIA),  
MICROSCOPY, ETC.\*

---

---

ZOOLOGY.

VERTEBRATA.

a. Embryology.†

Parental and Grand-parental Components of the Nucleus.‡—V. Häcker makes another important contribution to our knowledge of the morphological aspect of inheritance. His chief results, apart from theoretical deductions, may be summed up in four statements.

(1) The “*gonomeric*” constitution of the nucleus, i.e. its composition out of autonomous paternal and maternal contributions, may be followed in the developmental history of Copepods from the fertilised ovum to the primordial sex-cells of the offspring.

(2) During the maturation of *Cyclops* there is a re-arrangement of the chromatin-elements in such a way that the ovum acquires grand-paternal and grand-maternal elements in equal mixture. With this re-arrangement there is associated a pairing of each grand-paternal chromosome with a grand-maternal chromosome.

(3) It is highly probable that the “*gonomeric*” constitution of the nucleus is of wide, if not general, occurrence in sexually reproduced organisms, especially in genital and in epithelial cells.

(4) There is a close connection between the idiomeric and the gonomeric constitution of the nucleus, in this sense, that the latter may be regarded as a limit-case of the former (der letztere gewissermassen als ein Grenzfall des ersteren erscheint).

But this brief report gives but a general hint of the drift of a memoir which is as intricate as it is important.

Maturation in Newts' Ova and in General.§—W. Lubosch has especially investigated the behaviour of the nucleolar substance during

\* The Society are not intended to be denoted by the editorial “we,” and they do not hold themselves responsible for the views of the authors of the papers noted, nor for any claim to novelty or otherwise made by them. The object of this part of the Journal is to present a summary of the papers as *actually published*, and to describe and illustrate Instruments, Apparatus, &c., which are either new or have not been previously described in this country.

† This section includes not only papers relating to Embryology properly so called, but also those dealing with Evolution, Development, Reproduction, and allied subjects.

‡ Jenaische Zeitschr. f. Naturwiss., xxxvii. (1902) pp. 296-400 (4 pls. and 16 figs.).  
§ Tom. cit., pp. 217-96 (5 pls.).

maturation. There are two essential processes involved. The first is the metamorphosis of the primitive nuclear framework, which passes from a concentrated state to one of fine distribution; and the second is a reverse process of aggregation. No observation compels one to believe that the nuclear framework is ever wholly lost. The nucleoli are not in any way mere ballast, or like the fifth wheel on a waggon, as Born's results would suggest. On the contrary they are bodies into which, at definite epochs in the maturation, part of the chromatin passes, to undergo definite transformations, and to be restored again in filamentar form to the nuclear structure.

Lubosch regards the maturation-phenomena of the germinal vesicle as adaptations of the nucleus to altered vital conditions, enabling it to preserve its hereditary equipment. The arrangements involved in this adaptation may secondarily acquire a functional importance which was not primarily implied in their origination.

**Hermaphroditism in Fishes.\***—L. Roule refers to a recent memoir by Stéphan, and notes that there are records of hermaphrodite and protandrous fishes. He has himself studied the question in reference to Cyprinidae, and cites the cases of a lot of 170 sexually mature red-eyes (*Scardinius erythrophthalmus*) taken from an emptied pond. The lot was composed as follows:—91 specimens, from 2 cm. to 7 cm. in length from the posterior margin of the eye to the base of the tail, were all males; of 25 specimens, 8 cm. to 9 cm. in length, 13 were males and 12 females; of 54 specimens, 10 cm. to 19 cm. in length, all were females. Thus, in a chance lot, the number of males was in excess of that of females, and male sexual maturity occurred in forms smaller than those in which female sexual maturity was seen.

What is the interpretation? Is there strict unisexuality, with relatively dwarfed males? Or is there protandrous hermaphroditism? As far as the author has been able to judge, histological examination favours the second interpretation.

**Carnivorous Fowls of the Second Generation.†**—F. Houssay notes that the structural changes in fowls induced by carnivorous diet are much more marked in passing from the first (graminivorous) set of the birds to their carnivorous progeny, than in passing from the latter to the second exclusively carnivorous generation. In this communication he deals with the second carnivorous generation.

(1) Some structural features show no change, e.g. quantity of blood, weight of heart, weight of liver.

(2) Some structural features are on the decrease, e.g. the capacity of the crop, the length of the intestine, the length of the cæca, the size of the whole stomach, of the gizzard, and of the pancreas.

(2) Some structural features are on the increase, e.g. the weight of kidneys, lungs, and spleen.

**Early Stages in Development of Ornithorhynchus.‡**—J. T. Wilson and J. P. Hill describe an early stage in an egg of *Ornithorhynchus*,

\* Comptes Rendus, cxxxv. (1902) pp. 1355-7.

† Tom. cit., pp. 1357-9 (1 fig.).

‡ Proc. Roy. Soc. London, lxxi. (1903) pp. 314-22 (2 figs.).

measuring 10 by 9.5 mm. The particular interest of the stage is that the primitive streak area co-exists with, though independent of, a primitive knot whose interior is penetrated by the archenteric or gastrula-cavity. The mere fact of the co-existence of the streak with the knot at this stage necessitates some reconsideration of the morphological relationship of the mammalian primitive streak to the process of gastrulation.

**Development of Vertebral Column of Penguin.\***—H. Männich gives a careful account of the development of the backbone in *Eudyptes chrysocome*, and the most interesting general result is a demonstration of the large number of primitive reptile-like skeletal peculiarities, which are much more marked in this isolated and ancient stock than in most other birds.

**Development of Beak of Penguin.†**—M. Lewin describes the development of the anterior part of the skull in *Eudyptes chrysocome*. He notes *inter alia* that derivation from flying birds is suggested by the air-spaces which extend from the nasal chamber into the beak on to the middle of embryonic life, thereafter dwindling and eventually disappearing. But the divergence from the main Carinate stock must have been early, as is suggested by the persistence of various Saurian features, e.g. the long-continued separateness of the bones of the skull, and the nature of the lachrymal canal.

**Development of Corpus Vitreum.‡**—M. von Lenhossék has studied this in rabbit, cat, ox, and man. The vitreous body as a whole is a product of the lens, and therefore of ectodermic origin. Its cells are compared to the ependym-cells of the central nervous system. The fibrillar vitreous substance forms a unified coalescent framework; the relations of its fibrils to the retina are quite secondary. The membrana hyaloidea is derived from the retina, and has nothing genetically to do with the vitreous body. The capsule of the lens is a cuticular formation from the cells of the lens-vesicle.

#### b. Histology.

**Nature of the Centrosome.§**—D. N. Voinov has studied the centrosome, particularly in the V-form which it exhibits in the spermatocytes of various insects. He concludes that the centrosome is a real structure, a true cellular organ, possessing some degree of autonomy, and some persistence of form apart from structural changes in the cells. It grows and develops by its own activity. It is transmitted by division from one cell-generation to another, and may exhibit a precocity of development—the V-form—in certain cases of rapid cellular transformation.

**Laws of Division.||**—P. A. Dangeard recalls the law of Hertwig, that the two poles of the nuclear spindle lie in the direction of the largest masses of protoplasm, and the law of Pflüger, that the nuclear spindle is orientated in the line of least resistance.

\* *Jenaische Zeitschr. f. Naturwiss.*, xxxvii. (1902) pp. 1-40 (1 pl.).

† *Tom. cit.*, pp. 41-82 (2 pls. and 5 figs.).

‡ 'Die Entwicklung des Glaskörpers,' Leipzig, 4to. 106 pp., 2 pls., and 19 figs.

§ *Arch. Zool. Expér.*, i. 4th series (1903) *Notes et Revue*, No. 2, pp. xvii.-xxiv.

|| *Comptes Rendus*, cxxxvi. (1903) pp. 163-5. 2

Dangeard's study of Flagellates shows (1) that these laws have only a secondary importance, and (2) that they express the result of modifications introduced into the cellular organism in the course of evolution. The division in Flagellates is often quite contrary to the laws of Hertwig and Pflüger.

Dangeard re-states the laws of division :—

(1) The nuclear axis is disposed at right angles to the cellular axis or to the cellular plane if there is one.

(2) The plane of division passes through the axis or the cellular plane, and these are determined by the general morphology of the cell and the position of its permanent elements.

Taking the cases of *Euglenopsis vorax* and *Trachelomonas volvocina*, Dangeard shows that the primary laws are modified by the appearance of a membrane or non-extensible membrane. The laws of Hertwig and Pflüger relate to this secondarily induced modification.

**Size of Nerve-Fibres in Fishes.\***—C. J. Herrick directs attention to Miss Dunn's observations upon the relation between diameter and distribution of nerve-fibres in the frog. They recall some facts which he noted in regard to fishes. He concludes that each functional system of peripheral nerves has tolerably definite fibre-characteristics, the basis for which is as yet unknown; that these characteristics are by no means invariable, but that the fibres of a given system may show considerable differences in calibre and medullation in a single animal; and that some of these differences, at least, may be correlated with the degree of functional development of the peripheral end-organ. In general, highly developed muscle-fibres, sense organs, &c. receive larger nerve-fibres, than similar organs in a state of structural and functional degradation.

**Nerve-Endings in White Muscle.†**—A. Motta Coco and S. Distefano have studied the nerve-terminations in the white muscle of the rabbit, and have shown that these are distinctly different in structure from those on the red muscles.

**Integumentary Organs of Cervidæ.‡**—E. H. Zietzschmann has studied the minute structure of various organs beneath the skin of Cervidæ. He begins with the hair-tufts on the tarsal or metatarsal regions, or on both. These tufts differ in colour from the adjacent parts, the hairs are usually longer and coarser, and more closely packed (except in the roe deer). In many cases there are associated hairless patches. The skin of the hair-tufts is specially thick and shows a crowding together of tubular and acinous glands.

Secondly, the author discusses the "*Brunftalten*" in *Cervus elaphus*—a folding of the skin in the position of the antlers in females and young males. All three layers of the skin are folded; there is no increase in the tubular (sweat) glands, and there is no very marked increase in the acinous glands; in young males, indeed, the latter are absent. Similar structures in other forms are described.

The head-folds of *Cervulus muntjac* are then dealt with; they show

\* Journ. Comp. Neurol., xii. (1902) pp. 329-34.

† Anat. Anzeig., xxii. (1903) pp. 457-66 (3 figs.).

‡ Zeitschr. wiss. Zool., lxxiv. (1903) pp. 1-63 (3 pls.).

marked increase in the volume of the corium, involving the connective tissue and both kinds of glands. Fourthly, the author describes a peculiar, coffee-brown structure between skin and fascia in the region of the last eight lumbar vertebrae in *Cervus elaphus*, *C. canadensis*, *C. axis*, and *Cariacus campestris*. It consists of a connective-tissue reticulum with many blood-vessels, isolated nerves, and large round cells in the meshes. It recalls the glandula coccygea or the glandula carotica.

**Optic Chiasma of Reptiles.\***—J. Gross has studied the chiasma nervorum opticorum in various reptiles, as a contribution to the discussion of a problem which has been the subject of controversy since the time of Galen. In the slow-worm, the gecko, *Lacerta*, and two snakes, it seems clear that the crossing is total; in Chelonians and the chameleon the case is not so clear, but it seems most probable that in these as in other cases the crossing is total not partial. The histological details are described in the different cases, which show remarkable diversity. A very simple mode of crossing was probably primitive in Reptilia, and *Anguis fragilis* is nearest the original simplicity. It is interesting to notice how this research corroborates from the study of the details of the chiasma conclusions which have been otherwise reached in regard to the phylogenetic relationships of reptiles.

#### General.

**Biogen-Hypothesis.†**—Max Verworn states as a working hypothesis a new version of an old idea. Metabolism depends on the continual breaking-down and continual building-up of a very labile chemical combination—the biogen-substance. This has its seat in the cytoplasm of the cell, rather than in the nucleus, which does not in itself show respiratory changes.

**Note on Physiological Injections.‡**—Yves Delage points out that the method of injecting carminate of ammonia, indigo-carmin, and the like, and observing where these substances are localised, is good so far as it goes, but that it is apt to lead to fallacious conclusions. The substances in question are not products of normal excretion, and it does not follow that the organs which excrete them after injection are excretory in the normal metabolism, or that the organs which do not excrete them may not be truly excretory. And to say that organs which fix and accumulate the artificially introduced substances are excretory at all, is like saying that the nervous system is excretory because it fixes methylen-blue.

**Experiments with Adrenalin.§**—Ch. Bouchard and H. Claude remark on the remarkable properties of adrenalin as an agent inducing vaso-constriction. They have made experiments (on rabbits) as to its toxicity. The fatal dose of a solution injected into the veins is between .1 and .2 mgrm. per kilogramme. In the intoxication there are

\* Zool. Jahrb., xvii. (1903) pp. 762-88 (2 pls.).

† 'Die Biogenhypothese. Eine kritische-experimentelle Studie über die Vorgänge in der lebendigen Substanz.' Jena, 1903, 8vo, 114 pp.

‡ Comptes Rendus, cxxxv. (1902) pp. 936-7. § Tom. cit., pp. 928-31.

nervous and cardio-pulmonary disturbances. A certain diminution of susceptibility can be induced by repeated doses. Subcutaneous or peritoneal injection is not followed by nervous or respiratory disturbances, but induced by glycosuria.

**Modifications observed in Carnivorous Fowls.\***—F. Houssay compares, as to moulting, excretion, and weight of kidneys, three sets of fowls, (*a*) graminivorous, (*b*) carnivorous for one generation, and (*c*) carnivorous for two generations. He shows a marked and progressive increase in the weight of feathers lost in moulting, a marked increase in the weight of the kidneys and in the amount of uric excretion.

**Classification of Birds.†**—R. W. Shufeldt discusses in a learned paper the classification of certain groups of birds. We cannot do more than indicate his mode of arrangement.

### I. Order Saururæ.

<i>Supersuborder.</i>	<i>Suborder.</i>	<i>Superfamily.</i>	<i>Family.</i>
Archornithiformes.	Archornithes.	..	Archæopteridæ,
	Including <i>Archæopteryx</i> , and, provisionally, <i>Laopteryx</i> .		

### II. Order Ornithuræ.

<i>Supersuborder.</i>	<i>Suborder.</i>	<i>Superfamily.</i>	<i>Families.</i>
Dromæognathæ.	Struthionithes.	..	Struthionidæ.
			Rheidæ.
	Casuariornithes.	..	Dromaiidæ.
			Casuaridæ.
			Dromornithidæ.
Dinornithes.	..	Dinornithidæ.	
Æpyornithes.	..	Æpyornithidæ.	

### Supersuborder III. Odontoholcæ.

<i>Suborder.</i>	<i>Superfamily.</i>	<i>Families.</i>
Pygopiformes.	Hesperornithoidea.	Hesperornithidæ. Enaliornithidæ.

Of all these, careful diagnoses are given by this well-known ornithological expert.

**Birds of North and Middle America.‡**—Robert Ridgway has published the second part of his descriptive catalogue, which deals with the Tanagers (Tanagridæ), Troupials (Icteridæ), Honey Creepers (Cœrebidæ), and Wood-Warblers (Mniotiltidæ).

**Course of the Taste-Fibres.§**—H. Cushing draws some interesting deductions from thirteen cases of Gasserian ganglion extirpation. (1) The perception of taste is unaffected on the posterior portion of the tongue, and never permanently or completely lost on its anterior two-thirds after removal of the Gasserian ganglion. (2) A temporary

\* Comptes Rendus, cxxxv. (1902) pp. 1061-3.

† Amer. Natural., xxxviii. (1903) pp. 33-64 (1 fig.).

‡ Bull. U.S. Nat. Museum No. 50 (1902) xvii. and 834 pp. (22 pls.).

§ Bull. Johns Hopkins Hospital, xiv. (1903) pp. 71-8 (2 figs.).

abolition or lessening of the acuteness of taste may be found to exist over the anterior and anæsthetic portion of the tongue for some days after the operation. (3) This temporary loss of function may possibly be occasioned by some interference with chorda transmission brought about by a mechanical or toxic disturbance due to degeneration of the *N. lingualis*. (4) A lesion of the trigeminal nerve may be associated with disturbance of taste over the chorda territory without the necessary inference that this nerve is a path for gustatory impulses. (5) *The trigeminal in all probability does not convey taste-fibres to the brain either from the anterior or posterior portion of the tongue.*

**Note on the Great Sea Serpent.\***—E. G. Racovitza discusses seriously what Oudemanns and others have recorded concerning *Megophias*, the Great Sea Serpent, and publishes a report of the observations of M. Lagrèsille on a huge animal seen in 1898 in the waters off Tonkin. That something remarkable was seen seems beyond doubt, and Racovitza gives detailed directions as to future observation. The Zoological Society of France has decided to send fifty copies of the paper to observers in the region which *Megophias* is believed to favour.

**Largest known Dinosaur.†**—Elmer S. Riggs describes the remains of *Brachiosaurus altithorax* g. et sp. n., a herbivorous Dinosaur of huge proportions from the Jurassic of western Colorado. The specimen consists of the humerus, coracoid, femur, and ilium, all from the right side; the sacrum, seven thoracic and two caudal vertebræ, together with a number of ribs and other bones. The humerus measured 2·04 metres in length, the femur 2·03 metres, and the animal was not only the largest and longest-limbed of all known land animals, but is also the only known Dinosaur in which the humerus surpasses the femur in length. "Assuming that the lower fore-leg bones were proportionately long, we have to do with a creature whose shoulders were carried far above his hips, and whose fore-legs played a more important part than the hind ones. Such proportions at once suggest arboreal food-habits. Instead of rearing upon the hind-legs and supporting itself by means of a ponderous tail, as were the evident habits of *Brontosaurus* and *Diplodocus*, this animal may from sheer length of limb have been able to browse at will upon the foliage of tree and shrub." It was the giraffe among Dinosaurs, just as *Claosaurus* was the kangaroo.

**Optic Chiasma in Teleosts.‡**—G. H. Parker has examined ten common symmetrical Teleosts (*Fundulus*, *Menidia*, *Gadus morrhua*, &c.), and finds that the optic chiasmata are dimorphic, in that in some instances the right optic nerve is dorsal, in others the left. In a thousand cases the right nerve was dorsal 514 times, the left 486 times. The two types of chiasmata are not correlated with sex.

In the Soleidæ the chiasmata are also dimorphic. In Pleuronectidæ they are monomorphic for each species; in dextral species the left nerve is dorsal, in sinistral species the right.

All species of Pleuronectids that turn in only one direction have

\* Bull. Soc. Zool. France, xxviii. (1903) pp. 11–29 (3 figs.).

† Amer. Journ. Science, xv. (1903) pp. 299–306 (7 figs.).

‡ Bull. Mus. Zool. Harvard, xl. (1903) pp. 221–42 (1 pl.).

their dorsal nerves connected with their migrating eyes. In all species that have both dextral and sinistral individuals, the dorsal nerve is connected with that eye which in the greatest number or in the nearest of kin migrates.

The unmetamorphosed young of the Pleuronectidæ are not symmetrical in the same sense that symmetrical Teleosts are, for they have monomorphic chiasmata. The Soleidæ are not degraded Pleuronectidæ, but degenerate descendants of primitive flat-fishes, from which the Pleuronectidæ have probably been derived. The monomorphic condition of the optic chiasma of the Pleuronectidæ can be explained only on the assumption of natural selection. The flat-fishes afford striking examples of discontinuous variation.

**Lateral Canals and Cranial Bones of *Polyodon folium*.**\*—E. Ph. Allis, jr., discusses these, and proposes certain homologies which show, if correct, that while *Polyodon* more closely approaches Selachians in the arrangement of its lateral canals than any known Teleost or other Ganoid, the bones enclosing these canals more closely approach the arrangement found in Amphibians than those of any other known living fish, excepting *Clarias*, which, according to Huxley, closely approaches *Coccosteus* in its dermal armature.

The conditions found in *Polyodon*, moreover, definitely establish the fact that there is a definite lateral canal component in certain of the so-called dermal bones of the skull of fishes, and that this component may be found wholly separate and distinct from another, so-called membranous component that may form part of the same bones. Is then this lateral component retained after the sensory organ or organs in relation to which it has developed have disappeared? That it may be retained without a related enclosed organ is certainly shown by the presence, in *Conger*, of a postauditory squamosal canal ossicle without such a related organ.

**Flight of Flying Fish.**†—G. E. H. Barrett-Hamilton reports his observations on this much discussed subject. While some naturalists, such as Whitman, maintain stoutly that the fins of *Exocoetus* are flapped, others, such as Möbius, deny that genuine muscular movements ever occur. The author corroborates Moseley's observation that in *Exocoetus* at all events the wings are never moved as organs of true flight. They may vibrate or quiver under the action of air currents or the shifting a little of their inclination by the fish, but the whole motive power is supplied by the powerful tail. The wings are a parachute to augment the action of this propeller, but their motions are in no way comparable to those of the wings of a bird. It is suggested that some of the discrepancies in the descriptions of well qualified observers may be explained by supposing that different fishes were studied. There is really almost complete accord on the one important point, namely, that the so-called "fluttering" or "flapping," if it does occur, is almost invariably discontinued after the flight has really commenced. It is in nearly every case merely an accompaniment of the initial spring into the air.

\* Zool. Jahrb., xvii. (1903) pp. 659-78 (1 pl. and 2 figs.).

† Ann. Nat. Hist., xi. (1903) pp. 389-93.



**Brain of *Isistius brasiliensis*.**\*—R. Burkhardt has a note on the brain of this rare abyssal Selachian, remarkable in having its olfactory bulbs without peduncles, and situated at a great distance from the olfactory mucous membrane. In its general form the brain recalls that of Teleosts. The peculiarity is associated with the size and position of the eyes. In Teleosts likewise, the size and position of the eyes of the embryo are important in determining the configuration of the brain.

**Fresh-water Fishes of Borneo.**†—L. Vaillant makes a preliminary note on a rich collection acquired by the museum at Leyden. It includes 21 new species, including four new genera:—*Pseudolabis tetranema* and *Sosia chameleon* belonging to the Siluridæ, and *Gyrinocheilus pustulosus* and *Parhomaloptera obscura*, belonging to the Cyprinidæ. Another noteworthy form is a new species of the little known genus *Aperioptus*.

The fresh-water fauna of Borneo, as regards fishes, is very homogeneous, and it presents close resemblances to the Indo-Chinese fauna.

#### INVERTEBRATA.

**Relict Fauna of Lake Furesö.**‡—C. Wesenberg-Lund discusses the animal population of this lake in Zealand, which is very interesting in connection with the question of relict faunas. Furesö includes some remains of a marine fauna, the most ancient representatives of which (*Valvata*, *Bithynia*, &c.) belong to a very old-established and almost cosmopolitan fresh-water fauna adapted to lacustrine life at a period much anterior to the Ice age, and of quite unknown origin.

During the post-glacial epoch, which probably coincides with the submersion of the isthmus which united Scania with the Danish islands, towards the end of the period of *Ancylus*, there was a fresh immigration enriching the Furesö fauna by two new forms at least, viz. *Mysis oculata* var. *relicta*, and *Pontoporeia affinis*. These two Crustaceans, which still persist, are representatives of arctic forms whose immigration into the inner Baltic must have occurred while that was in communication with the Boreal sea. Their adaptation to fresh water must be referred to the time when the inner Baltic became "le lac à *Ancylus*," and it occurred in that lake. The other marine forms in Furesö probably immigrated in much more recent times. Such geological knowledge as is available forbids the idea that Furesö was an arm of the sea transformed into a lake by an elevation of land or otherwise. Except *Caligus lucustris* (brought by fishes?), and perhaps *Neritina fluviatilis* (brought by birds, &c.?), the marine forms now actually isolated in Furesö have probably arrived there in course of their own migrations. The presence in a lake of a marine fauna is no proof that the lake was once an arm of the sea.

\* Arch. Sci. Phys. Nat., xiv. (1902) pp. 534-5.

† Comptes Rendus, cxxxv. (1902) pp. 977-80.

‡ Oversigt K. Danske Vidensk. Selskab. Forhandl., 1902, No. 6 (published 1903) pp. 257-303 (1 map).

## Mollusca.

## γ. Gastropoda.

**Studies of Gastropod Shells.\***—Amadeus W. Graban regards the present geological period as that of the acme of Gastropods. What Jurassic and early Cretaceous ages were to the Cephalopods, the Tertiary and present periods are to the Gastropods. This is indicated not only by the great number of species, but also by the fact that so many series have branched out into bizarre types, in which excessive development of spines and tubercles suggests that the limit of variation is approached. Phylogerontic types are furthermore to be found in the majority of series, while some groups, such as *Strombus*, *Cypraea*, &c. are represented only by phylogerontic forms in the modern seas.

The author contributes very interesting short studies on the protoconch of Gastropods, the ornamentation of the protoconch, septa in the apex of Gastropods, the characteristics of the conch, the varices, other ornamental features, individual old age and phylogerontic characters in Gastropods, illustrations of the law of tachygenesis and of parallelism among Gastropods. He sums up the result of his studies in the words of Hyatt's law of morphogenesis: "A natural classification may be made by means of a system of analysis in which the individual is the unit of comparison, because its life in all its phases, morphological and physiological, healthy or pathological, embryo, larva, adolescent, adult, and old (ontogeny), correlates with the morphological and physiological history of the group to which it belongs (phylogeny)."

**Kidney of *Helix pomatia*.†**—G. Stiasny gives a detailed account of this organ, in regard to which many, if not most, text-books have made erroneous statements. He distinguishes the kidney proper, the primary ureter, which extends from an opening at the apex of the kidney to the posterior corner, and the secondary ureter which runs from the posterior corner of the kidney to the external aperture.

**Sense of Smell in Snails.‡**—Emile Yung has made experiments with snails and slugs as to their sense of smell. He notes that the seat of the sense has been sought on the long-horns (near the eye), on the short horns, about the lips, at the pulmonary opening, in the vicinity of the pedal gland, and so on. The fact is that the general surface of the skin is sensitive to strong odours, and both pairs of horns especially. A snail deprived of its horns still finds its food and behaves as usual. The sensitiveness in all cases has a very short radius.

**Purple of *Purpura lapillus*.§**—A. Letellier gives a short account of the researches which have been made on the "purple" of the dog-whelk, and re-expounds his own results. He has found in the secretion three distinct bodies—a yellow substance which does not change on exposure to light, and two kinds of green substance, one changing quickly to blue in sunlight, the other becoming carmine red. The combination of these three substances gives a coloration first yellow, then green to blue,

\* Amer. Natural, xxxvi. (1902) pp. 917-45 (18 figs.).

† Zool. Anzeig., xxvi. (1903) pp. 334-44 (5 figs.).

‡ Arch. Sci. Phys. Nat., xiv. (1902) pp. 536-7.

§ Arch. Zool. Expér., i. 4th series (1903) Notes et Revue, No. 2, pp. xxv.-ix.

and finally sombre red. Extracts of the gland in alcohol, ether, or chloroform give the purple colour on exposure to light, a phenomenon probably associated with the oxidation of the photochemical substances. He finds no contradiction in the results reached by Dubois, whose work deals with antecedent stages, or in his theory that the secretion which becomes purple on exposure to light is the outcome of an interaction between a ferment (purpurase) and another substance (purpurin). Letellier did not go so far back, his observations dealt with the already formed secretion.

**Nematocysts of Nudibranchs.\***—O. C. Glaser discusses the interesting question whether the cnidoblasts observed in Eolididæ are really parts "of the organic make-up" of these molluscs, or have been incorporated from the hydroids among which the nudibranchs live. His results are inconclusive, i.e. his facts can be explained on the assumption that the nematocysts do not really belong to the molluscs. "If this hypothesis is true, we are dealing with a most remarkable adaptation, in which weapons are taken from one animal and actually used by another." At all events, "there are good reasons why the origin of the nematocysts of the Eolididæ should be carefully studied." "Such study may show that they are not part of the organic make-up of the animals possessing them."

**Tracheopulmonate Gastropods.†**—G. Glamann has studied some of the remarkable Australasian Janellidæ, in which there are only two tentacles, and in which there is "a tufted lung" (*Büschellunge*), with diverticula and respiratory tubules surrounding the pulmonary cavity and allowing of gaseous exchange between the tubules and the hæmolymp in the large dorsal sinus embracing the lung.

The author gives a detailed account of *Aneitea græffei*, and *Aneitella virgata*; a diagnosis of the Janellidæ, a key to the species of *Aneitea*, and a re-statement of the characters of the four genera—*Janella*, *Triboniophorus*, *Aneitea*, and *Aneitella*.

#### 5. Lamellibranchiata.

**Origin of Pearls in *Mytilus gallo-provincialis*.‡**—R. Dubois notes that his observation that the pearls of *Mytilus edulis* are due to a parasitic fluke was independent of the work of Gardner (1871) and of Lyster Jameson. He has also found in *M. gallo-provincialis*, which differs in habitat and environmental conditions, another species of fluke also causing pearls. In pearls from *Anodonta cygnea*, he found no trace of parasites, and thinks that the theory of the parasitic origin of pearls must not be hastily generalised.

#### Arthropöda.

##### a. Insecta.

**Evolution of Colour-Patterns in Lepidoptera.§**—A. G. Mayer has inquired into the effects of natural selection and race-tendency upon the

\* Johns Hopkins Univ. Circ., xxii. (1903) pp. 22-4.

† Zool. Jahrb., xvii. (1903) pp. 679-762 (6 pls. and 9 figs.).

‡ Comptes Rendus, cxxxvi. (1903) pp. 178-9.

§ Publications of Museum of Brooklyn Inst. Sci. Bulletin, i. No. 2 (1902) pp. 31-86 (2 pls.).

colour-patterns in 1173 species—453 of *Papilio*, 30 of *Ornithoptera*, 643 Hesperidæ, and 47 of *Castnia*. There are three sorts of markings upon the wings of Lepidoptera :—spots, bands, and “combination-markings,” linear combinations of spots and bands. Some general “laws of variation” are stated, e.g. that departures from the normal are much more apt to affect the ends than the middle of a marking; like kinds of markings are more apt to fuse than unlike, and so on.

Mayer finds that *Papilios* belonging to different subgenera, and living in widely separated parts of the world display a number of similar peculiarities of colour-pattern. Some of these peculiarities are constant among groups of *Papilios* which differ greatly in general appearance, live in dissimilar environments, and are subject to the attacks of dissimilar enemies. As some of these peculiarities are too insignificant to affect the general appearance of the insects, and remain the same under widely different conditions of selection and environment, they appear to be due neither to natural selection nor to environmental influences. They may, however, be due to a conservatism in heredity, or race-tendency, which has remained constant in the majority of the species despite the changes which time, selection, and all other causes have produced.

The characteristic differences between the species of a genus, or the genera of a family, group themselves about certain dominant conditions, most of these differences being only slight departures from the dominant form. Each genus or family displays its own peculiar conditions, and follows its own peculiar law of differentiation. On the whole this research favours the theory that new species have often arisen by mutation independent of environment and in many cases not interfered with by adverse selection. This conclusion accords very well with what De Vries has recently observed in the mutations of such plants as (*Enothera*).

**Net-winged Midges.\***—V. L. Kellogg notes that the net-winged midges or Blepharoceridæ have long been of peculiar interest to entomologists because of the small number of known species and their supposed rarity, because of the wide and discontinuous distribution, because of the remarkable aquatic life of larvæ and pupæ, and the strange modification of the body in both these stages in conformity with the curious habits, and because of the unique pseudo-net-veining of the wings of the imagines, produced by a series of folds in the wing membranes. Kellogg has called attention to other interesting features, especially the composition of the compound eyes of the imagines of two sizes of ommatidia, with differences in disposition of the retinal pigment, &c., resulting in a certain accommodation to different intensities of light. In the present paper the author describes four new North American species and their immature stages (which live submerged in swift clear streams). He gives an account of some of the structural peculiarities of both larvæ and adults, e.g. the larval suckers and the imaginal eyes; and discusses the habits and life-history so far as these are known. A

\* Contributions from Hopkins Lab. Leland Stanford Jr. Univ., No. xxx. Reprint from Proc. California Acad., 3rd ser. (Zoology) iii. pp. 187-232 (5 pls.).

statement has been added of the more serious deficiencies in our knowledge of this interesting family.

**History of Polar Bodies in Drone-Ova.\***—A. Petrunkevitch has shown that while the polar bodies of the fertilised ova of the bee come to nothing, the state of affairs in the unfertilised ova (drone-ova) is very different. The second polar body coalesces with the internal half of the first, and thus gives rise to the so-called "directive-copulation-nucleus" with the normal number (16) of chromosomes. The nucleus soon forms the "directive-copulation-spindle," and divides into 2, 4, 8 cells with double nuclei. What becomes of these direct derivatives of the polar bodies? After prolonged investigation Petrunkevitch has satisfied himself that they give rise to the primitive sex-cells of the male. The difference between the origin of the primitive genital cells in the two sexes is striking.

**Development of Wings in Beetles.†**—W. L. Tower has studied this in a variety of forms. He finds that the wings and the spiracles arise in homologous positions upon the sides of the segments as determined by the attachment of homodynamous muscles. He believes that the hind wings are derived from the degenerate spiracle disc of the metathorax. In the elytra the case is different. Whether in the migration of the mesothoracic stigma to its larval position only the opening migrates and the disc remains behind, or whether both the spiracular disc and opening are moved forward, remains undecided. The author's evidence points strongly to the view that it is the spiracular opening alone which migrates, and that the spiracular disc remains behind to form the primordium of the elytron. At present the evidence seems strongly in favour of Verson's (1890) view that the wings of Coleoptera and Lepidoptera are derived from the rudiments of the mesothoracic and metathoracic spiracles. The evidence is positively opposed to the theory that the wings originate as dorsal backward prolongations of the tergum, and the theory that wings are derived from structures like tracheal gills lacks substantial support.

**Screw-Worms in St. Lucia.‡**—St. George Gray discusses the occurrence of this parasite in man, where, as in cattle, &c. it is sometimes fatal. The screw-worm is the larva of a small fly—*Chrysomyia (Comptosyia) macellaria* Fabr. The eggs are laid in wounds and in openings of the body, e.g. mouth and nostrils; they hatch in 1–9 hours. The larvæ are rather slender, whitish, active maggots, with twelve segments, each bearing a ring of minute spines or bristles, suggesting the appearance of a screw; they burrow into the tissues, devouring even bones, and may penetrate into the cranial cavity; they mature in a week or less, and a pupa stage of 9–12 days is passed in the ground, in crevices, in bedding, &c. The author recommends the destruction of filth, carcasses, &c., the careful covering of wounds, the use of mosquito netting or wire gauze in sleeping rooms, and the protection of the nostrils in places where the flies are common.

\* Zool. Jahrb., xvii. (1903) pp. 481–514 (3 pls.).

† Tom. cit., pp. 517–72 (7 pls. and 8 figs.).

‡ Brit. M. d. Journ., No. 2204, March 28, 1903, pp. 724–5.

**Parasite of the Wallaby.\***—W. Wesché describes under the provisional title *Hippobosca tasmanica* sp. n., one of the Hippoboscidae, parasitic on the Wallaby (*Macropus ruficollis*). It is remarkable for two curious spined tubercles—one might almost call them epaulets—on the shoulders, a median suture on the thorax, and a peculiar venation of the wings. Sick wallabies are said to swarm with them.

**Parasitic Bacteria in Intestine of Chironomus Larvæ.†**—Louis Léger notes that apart from frequent inclusions, three kinds of Bacteria are true parasites of the intestine of the larvæ of *Chironomus plumosus*. The three forms which he describes belong to the genera *Streptothrix* Cohn, *Bacillus* Cohn, and *Spirochæte* Ehrenb. Léger suggests that the presence of the *Spirillum*-forms may be the explanation of Vignon's observation—which is somewhat difficult to credit—that the intestine of the *Chironomus*-larvæ bears vibratile cilia in certain regions. The undulating bacteria were seen in these very regions of the intestine.

**Antennary Sense-Organs in Lepidoptera and Hymenoptera.‡**—O. Schenk has especially studied *Fidonia piniaria*, *Orgyia antiqua*, *Psyche unicolor*, *Ino pruni*, *Vespa crabro*, and *Apis mellifica*. He finds that the degree of development of the antennæ is associated with the development and distribution of various kinds of sense-organs thereupon.

In Lepidoptera he distinguishes (*a*) sensilla cœloconica (olfactory), sensilla styloconica (olfactory), sensilla trichodea (associated with perception of movements in the air or of the insect itself), sensilla chætica, and sensilla basiconica (both sensitive to mechanical stimuli).

In Hymenoptera he distinguishes sensilla placodea (responsive to mechanical stimuli?) sensilla cœloconica and styloconica (olfactory), sensilla ampullacea (auditory?), and sensilla trichodea (responsive to mechanical stimuli).

**Insect against Insect.§**—Costantino Ribaga gives an interesting account of the invasion of *Iceria purchasi* Mask. into Italy, of the subsequent importation of *Novius cardinalis* Muls., and of the relative success of the ensuing struggle for existence.

**Changes in Imagines induced by Change of Diet in Caterpillars.||**—Arnold Pictet finds that if caterpillars of *Bombyx quercus*, *Ocneria dispar*, *Psilura monacha*, &c. are fed on plants which do not form their natural food, noteworthy changes in the coloration of the adults result. In the case of *Ocneria dispar* notable dwarfing and blanching were effected.

**Dorsal Glands of Larvæ of Hemiptera-Heteroptera.¶**—J. Gulde has dealt very thoroughly with these glands, which secrete a substance with an unpleasant smell, and are doubtless protective. They occur on the abdomen and replace in the larvæ the thoracic glands of the imagines. They are possessed by all Geocorisæ except the Hydro-

\* Ann. Nat. Hist., xi. (1903) pp. 384-5 (4 figs.).

† Comptes Rendus, cxxxiv. (1902) pp. 1317-9.

‡ Zool. Jahrb., xvii. (1903) pp. 573-618 (2 pls. and 2 figs.).

§ Rev. Patol. Vegetale, x. (1903) pp. 299-323.

¶ Arch. Sci. Phys. Nat., xiv. (1902) pp. 537-40.

¶ Ber. Senckenberg. Nat. Ges., 1902, pp. 85-132 (2 pls.).

metridæ, and they are absent in Hydrocorisæ. In form like small sacs, with backward directed pores, they arise as integumentary invaginations. Their minute structure, their opening and closing, their oily acid secretion (cimicin acid,  $C_{15}H_{28}O_2$ , according to Carius), and other important details are described.

These dorsal glands show in their minute structure and in their position a close resemblance to the integumentary glands of Orthoptera cursoria (Blattidæ and Forficulidæ), and to the protective glands of Chilognatha. With both of these they are doubtless homologous.

**A Most Primitive Insect.\***—F. Silvestri describes *Anajapyx vesiculosus* g. et sp. n., a new Thysanuran from Italy, which is in many ways the most primitive insect known, even more primitive than *Projapyx*. It perhaps represents an early offshoot from the progenitors of the Progoneata (Symphila and Diplopoda). The new genus combines in a remarkable manner characters of the Symphila and Diplopoda (posterior glands and ventral vesicles), characters of the Campodeidæ (styliform appendages of the first sternite and the form of these stiles, which in Campodeidæ are restricted to segments 2-7); characters of the Japygidæ (presence of stiles even on the first segment of the abdomen and the nature of the tracheal system), and characters of the Lepismatidæ, perhaps only secondary, (great development of the anterior part of the intestine).

**Studies on Thysanura.†**—K. Escherich discusses in the first place the relations of the suggested genus *Lepismina* to *Lepisma* and *Grassiella*, between which it must be dissolved. An account is then given of the species of *Grassiella*, including three new forms from South Africa. The author then describes an interesting new myrmecophilous species, *Lepisma emilie* from Algiers, one of the peculiarities of which is that the head bears in front a number of thick tufts of radiating scale-hairs, each finely pinnate and curved in at the tip. In its form and in its black colour it is also notable. Three other new myrmecophilous species are described.

**Development of Spermatid of Notonecta glauca.‡**—J. Pantel and R. de Sinéty describe the final stages in the spermatogenesis, from the spermatocyte of the second order to the mature spermatozoon, paying particular attention to the development of the idiozomic corpuscles, the *Nebenkern*, the blepharoplast, and the mutation of the spermatid.

**Acrosome of Spermatid of Notonecta.§**—J. Pantel and R. de Sinéty have satisfied themselves that in this case the acrosome has an idiozomic origin and is not connected, as some have supposed, with the *Nebenkern*. The idiozome is gradually formed, at two periods, from two kinds of corpuscles, as a gradual differentiation of the cytoplasm as in higher Vertebrates. There is never any real fusion of acrosome and nucleus; the nuclear membrane seems to be persistent.

\* Ex. Ann. R. Scuola Agric. Portici, v. (1903) pp. 1-8 (1 fig.).

† Zool. Anz.-ig., xxvi. (1903) pp. 345-66 (12 figs.).

‡ Comptes Rendus, cxxxv. (1902) pp. 997-1000 (12 figs.).

§ Tom. cit., pp. 1124-6.

"Nebenkern" and Nuclein Movements in Spermatid of *Notonecta glauca*.\*—J. Pantel and R. de Sinéty state the three theories as to the origin of the *Nebenkern* and find support for the view of Meves. The formative material of the *Nebenkern* is the product of a very precocious differentiation, which may be seen even in the spermatocyte of the first order. It is due to mitochondrial bodies appearing in the cytoplasm.

The authors discuss the exchange of nuclein or nuclein-elements between the nucleus and the body of the cell, and the exchanges between nucleus and acrosome.

The nuclein movements which occur in the male cell in the course of its metamorphoses recall those in the oocyte. They are indices of the intricate process of sexual differentiation.

Stridulating Organs in Saltatorial Orthoptera.†—J. Regen gives a detailed account of the different forms of stridulating organs in Acridiidae, Gryllidae, and Locustidae. While the essential mechanism is the rubbing of a toothed bar against a ridge, there are many interesting differences in detail. The elytra may be rubbed against one another as in Gryllidae and Locustidae, or the elytra by the hind-legs as in Acridiidae, or the abdomen by the hind-legs as in *Pneumora*. There is a long series from the simple apparatus of some female Gryllidae to the complex differentiation in many Locustidae.

Structure of Gizzard of Carabidae.‡—L. Bordas describes the gizzards of *Carabus* (3 species), *Calosoma sycophanta*, and *Procrustes coriaceus*, and has been able to study the movements of the parts in the process of trituration.

Palæozoic and Recent Cockroaches.§—E. H. Sellards describes some new structural characters of Palæozoic cockroaches. They were very abundant in the carboniferous ages, and numerous specimens have afforded additional information as to head, antennæ, eyes, legs, hind wings, abdomen, ovipositors, cerci, and even young stages. "Evolution within the group, although not rapid considering the lapse of time since the Palæozoic, has been progressive and directly in the line of increased specialisation and differentiation of the organs affected." This is particularly well marked in the wings, which have become more specialised. But important changes are noticeable elsewhere. Thus in the abdomen, the terga and sterna have become modified, tending towards a reduction of the number of abdominal segments. The genital pouch has been perfected, and the ovipositors have become reduced and adapted to perform a specialised function. The long ovipositor of Palæozoic cockroaches apparently indicates that this was a primitive character of the Orthoptera. "In view of the fundamental and close relations, it seems evident that the Palæozoic and recent cockroaches constitute two nearly related and intergrading groups of a single order Orthoptera, or, more accurately, two stages in the evolution of a single phylum."

\* Comptes Rendus, cxxxv. (1902) pp. 1359-62.

† Arbeit. Zool. Inst. Univ. Wien, xiv. (1903) pp. 359-422 (2 pls.).

‡ Comptes Rendus, cxxxv. (1902) pp. 982-4.

§ Amer. Journ. Science, xv. (1903) pp. 307-15 (2 pls.).



## β. Myriopoda.

**Odoriferous Glands of *Julus communis*.**\*—G. Rossi describes the minute structure of the flask-shaped glands which occur, one on each side, in the pleural region of each segment—except the first four and those which form the apodal terminal region. He describes the spherical secretory cavity, the long neck-like excretory duct, the openings or “foramina repugnatoria,” the closing apparatus, and so on. A little is said about the physical, chemical, and toxic properties of the secretion, but it is difficult to get a satisfactory quantity. It is poisonous in subcutaneous injection, but not when swallowed.

**New Myriopods.**†—Carl Graf Attems gives in the first place an account of a collection made in Java by Dr. Hjalmar Möller. It includes ten new species and a new genus—*Haplosomides*, which agrees with *Haplosoma* except in having twenty trunk-segments instead of nineteen. Then follows a report on the collections made by Michaelsen in Chili, by Plate and Bürger in South America, and by Schauinsland in various oceanic islands. A new genus—*Dimerogonus*—of Cambalidæ has a pair of flagella on the anterior copulatory appendages, and is represented by two species; three other new species are described. The author then gives a systematic synopsis of the genera *Otostigma* and *Cryptops*, the former with three, the latter with four new species. The concluding part of the memoir deals with twenty-two new and some insufficiently described Palearctic species.

## γ. Prototracheata.

**Modes of Development in Onychophora.**‡—E. L. Bouvier discusses the diversity of embryonic development exhibited by various forms of Onychophora, and seeks in particular to show that the development of South African species of *Peripatopsis* is linked by gradations to that of *Paraperipatus Novæ Britannicæ*.

In *Paraperipatus Novæ Britannicæ* and in *Peripatopsis sedwicki* the segmentation results in a large ectodermic vesicle in which the embryonic area, always markedly transversal, only occupies a small extent; this vesicle elongates considerably, is pedunculated anteriorly, and is gradually reduced as the embryo develops.

In *Peripatopsis moseleyi* there is again a large vesicle and a small transversal embryonic area, but the vesicle does not elongate much, it is never pedunculated, and by the absorption of its contents it simply forms the walls of the median region of the body.

In *Peripatopsis capensis* the segmentation results in a small ovoid vesicle whose larger diameter does not exceed .7 mm.; the embryonic area, much longer than broad, occupies the whole ventral surface of the vesicle; and the dorsal surface of the latter forms the back of the embryo without ever showing the voluminous protuberance seen in *P. moseleyi*. It is probable that other species will show states in which the primary vesicle is more reduced than that of *P. moseleyi* and larger than that of *P. capensis*.

\* Zeitschr. wiss. Zool., lxxiv. (1903) pp. 64-80 (1 pl.).

† Zool. Jahrb., xviii. (1903) pp. 63-154 (7 pls.).

‡ Comptes Rendus, cxxxv. (1902) pp. 1033-6.

## 8. Arachnida.

**Segments of Pseudoscorpionidæ.\***—J. P. Stschelkanovtzeff has studied the metameric architecture of three species of *Chernes*. The cephalothorax (cephalon, prosoma) consists of nine segments; the segment with chelicerae is the third metamere, and corresponds to the intercalary segments in insects, and to that of the second antennae in Crustaceans; the mouth-opening lies in front of this metamere; remains of the sternum are seen in all the appendage-bearing segments of the cephalothorax except the first two.

The abdomen consists of eleven segments; the sternites of the first two segments share in forming the genital operculum; the genital aperture lies between the second and third abdominal segments. The stigmata lie between the first and second, and between the third and fourth. It is not justifiable to give segmental value to the conical protuberance on which the anus is situated; it has no trace of musculature indicative of independence. The total number of segments is twenty.

**Development of Dolomedes fimbriatus.†**—P. Pappenheim has studied the development of this large spider with special reference to the brain and eyes. The head-lobes of the embryo show no hint of antennae; there is no external segmentation of the head, but the head-lobes include a pair of pro-cheliceral coelomic cavities, suggestive of a pro-cheliceral segment independent of the acron. The primordium of the principal eyes is independent of the formation of the brain. The brain begins with the invagination of lateral vesicles, resulting in two semicircular pits. Two independent rostral folds form the principal eyes, which lie further back in the adult. The accessory eyes which appear in the region of the two lateral vesicles do not change their place much.

Pappenheim finds in the embryonic cephalothorax eight ganglionic primordia:—apical groove primordia, lateral vesicle primordia, cheliceral ganglia, pedipalp ganglia, and four other pairs corresponding to the legs. The embryonic abdomen shows a composition out of eight segments and a telson, but the nature of the abdominal nerve-cord indicates a larger number (perhaps ten) abdominal metameres.

**New Hydrachnida and Ixodidæ from South America.‡**—C. Ribaga describes the genus *Arrenurella*, various species of *Arrenurus*, *Eylais*, *Hydrachna*, and other new forms collected by F. Silvestri in South America.

**Sheep Scab.§**—This is the subject of a recent leaflet from the Board of Agriculture. The well-known disease is due to a mite, *Dermatodectes ovis* or *Psoroptes communis*, resembling the mange-mite of dogs and other animals. After a sheep-scab mite has been transferred directly or indirectly from a diseased to a healthy sheep, the female lays its eggs and dies. Under favourable circumstances the eggs are hatched in about seven days, and the young female parasites, after undergoing the

\* Zool. Anzeig., xxvi. (1903) pp. 318-34 (8 figs.).

† Zeitschr. f. wiss. Zool., lxxiv. (1903) pp. 109-54 (2 pls.).

‡ Ann. Scuola Sup. Agric. Portici, v. (1903) pp. 1-28 (2 pls.).

§ Leaflet No. 61 Board of Agriculture, 1903, pp. 6 (3 figs.).

various stages of their development, arrive at maturity in about two weeks, and proceed to lay more eggs. The male is somewhat smaller than the female, which measures  $\frac{1}{40}$  to  $\frac{1}{30}$  in., and each foot of the first three pairs of legs of the male is furnished with a sucker-disc, which in the case of the female is replaced on the third pair of feet by long hairs. The usually effective cure is to make the sheep swim in a bath of "dip," i.e. some preparation of white arsenic, carbolic acid, tobacco-juice, sulphur, &c. ; but prevention is better than cure.

#### 6. Crustacea.

**Integumentary Sense-Organs of Deep-Sea Decapods.\***—E. Kotte has made a detailed study of the appendages of *Plesionika cottei*, and of its tactile and gustatory organs. He also discusses in particular the sensory tufts on the thoracic appendages of *Nematocarcinus undulatus*. His general conclusions are the following:—(1) All the integumentary organs are sensitive; (2) they include a terminal strand, the distal process of a subjacent group of sensory cells, which is proximally connected with a nerve; (3) while in the lower Crustaceans only a few sensory cells are concerned with the innervation of a seta, there is a large number for each seta in the Decapods, especially in the abyssal forms; (4) in the course of the nerve-fibres which innervate the structures regarded as gustatory or olfactory, two cells are interpolated,—a peripheral ganglion-cell and a sensory cell.

**Excretion in Cirripedia.†**—L. Bruntz has used the injection method in studying the excretory organs in *Lepas anatifera*, *Pollicipes cornucopie*, *Balanus tintinnabulum*, and *Sacculina carcini*. In the three first he distinguishes three excretory organs:—(1) the maxillary kidney which eliminates injected carmin; (2) a closed cephalic organ, a lenticular body situated where the mantle is attached to the body; and (3) the hepatic gland. In *Sacculina* the only excretion detected was by osmosis over the whole surface of the absorptive roots.

**Ventral Nerve-Cord of Crayfish.‡**—B. Halpern describes the minute structure of the enveloping and supporting tissue of the ventral nerve-cord of *Astacus fluviatilis*. There are two sheaths,—the "perineurium" and the "endoneurium." The perineurium consists of connective-tissue strands and owes its firmness to a layer of elastic fibres. It forms the originally double septum between the connectives.

The endoneurium differs from the perineurium in structure and origin. It functions as the immediate sheath and support of the nervous substance. Each axis-cylinder is surrounded by two sheaths,—the internal one being a delicate membrane in which longitudinal fibrils are imbedded. The ganglia show (1) small cells with a double-contoured membrane, (2) "colossal" cells without a homogeneous membrane, but with a plexus of fibrils at the periphery, and (3) transition types between these.

\* Zool. Jahrb., xvii. (1903) pp. 619–58 (5 pls.).

† Comptes Rendus, cxxxv. (1902) pp. 987–8.

‡ Arbeit. Zool. Inst. Univ. Wien, xiv. (1903) pp. 423–42 (12 figs.).

**Gall-forming Copepod in an Anemone.\***—M. Caullery and F. Mesnil give an account of *Staurosoma parasiticum* Will, which forms galls in the mesenteries of *Anemonia sulcata* Penn. It does not seem to have been studied since it was detected and described by Will in 1844. The female, with the male fixed to it, is quite enclosed in the gall which contains a nutritive fluid. The eggs develop within the gall on to the nauplius stage. It seems that the parasitism begins during or soon after that stage. The systematic position of *Staurosoma* among Copepods must be a very isolated one.

**Australian Phyllopod.**†—O. A. Sayce has aimed at presenting a complete catalogue of the Australian Phyllopods. He has re-described and figured more amply those which seemed to need it, and has given sufficient descriptive detail for a fairly accurate identification of the various forms. Six new species are described, and it has been found necessary to institute two new genera,—*Parartemia*, which differs from *Artemia* in the shape of the prehensile antennæ of the male, and of the ovisac of the female, and in some other features; and *Branchinella*, which is closely allied to *Branchipus*.

#### Annulata.

**Typical Chloragogen of Oligochæta.‡**—D. Rosa has made an elaborate study of the typical chloragogen in *Tubifex*, *Fredericia*, *Lumbricus*, *Allolobophora*, &c. It is a modified peritoneum; its elements are never derived from lymphocytes and never give origin to lymphocytes; the bases of the chloragocytes always adhere to the walls of vessels, strictly to the matrix of their internal cuticle.

In lower Oligochæts the chloragocytes have contiguous basal plates forming a continuous investment. The subjacent muscle-fibres are variously altered in relation to the development of the chloragogen. The transformation of peritoneum into chloragogen may occur on the intestine, on the vessels entering the dorsal vessel, on the dorsal vessel, on the initial tract of the vessels leaving the dorsal vessel.

The function of chloragogen is essentially excretory, but it may also accumulate reserves, especially fat-globules. The excretory substances are represented by yellow chloragosomes, semi-liquid globules, formed in the cells out of materials received from the intestinal blood-vessels. The excretory materials accumulate slowly in the chloragocytes, and their rupture into the cœlom is more or less accidental, not essential.

**Atlantic Palolo.§**—A. G. Mayer gives an account of the Atlantic Palolo (*Eunice fucata* Ehlers). It is found at the Dry Tortugas, Florida, and lives within disintegrating coral rock or coquina from below low-tide level to a depth of at least six fathoms. Its breeding habits are closely similar to those of the well-known Pacific Palolo-worm, *Eunice viridis*.

\* Comptes Rendus, cxxxiv. (1902) pp. 1314-7.

† Proc. R. Soc. Victoria, xv. (1903) pp. 224-61 (10 pls.).

‡ Mem. R. Accad. Sci. Torino, lii. (1903) pp. 119-44 (1 pl.).

§ Science Bull. Brooklyn Museum, i. (1902) No. 3, pp. 93-103 (1 pl. and 2 figs.).

The Atlantic Palolo swarms at the surface before sunrise within three days of the day of the last quarter of the moon between June 29 and July 28. The posterior, sexually mature end of the worm breaks away from the anterior end, and swims backwards with great rapidity until about the time of sunrise, when it contracts, casting the genital products into the water. The anterior part remains in the coral rock.

The worm requires at least two years to attain sexual maturity. There are 57 p.c. of males and 43 p.c. of females. Only sexually mature forms cast off their posterior ends at the time of the swarm. Immature forms are about twelve times as numerous.

Cracking the coral rock induces premature expulsion of the genital elements. Eggs obtained in this way are immature and cannot be fertilised, even twelve hours before the time of the normal swarm. All the eggs mature simultaneously at that time.

The normally liberated eggs float in the water, and begin to segment soon after extrusion. The segmentation is total and unequal, the gastrula is formed by epibole, and the larva is telotrochal. The young larvæ swim near the surface, but sink to the bottom upon attaining four pairs of setigerous lobes. The posterior segment of the larva bears a pair of dorsal as well as a pair of ventral cirri. Only the ventral pair of cirri persist in the fully developed worm.

**Fresh-water Polychæts.**\*—Ch. Gravier notes that four families of Polychæts have representatives in fresh water. Among the Nereidæ there is *Lycastis ouanaryensis* Gravier from French Guiana. Mature female specimens were found in fresh water, but without the normal epigamous transformation. The Eunicidæ are represented by *Lumbri-conereis*, found by Kennel; the Capitellidæ by *Eisigella ouanaryensis* Gravier; and the Serpulidæ by *Manayunkia speciosa* Leidy, *Caobangia billeti* Giard, *Dybowskiella godlewskii* and *D. baicalensis* Nusbaum.

**Otocysts of Polychæta.**†—P. Fauvel has studied the otocysts which are especially characteristic of the Sabellidæ. They occur also in some Terebellidæ, in Arenicolidæ, in two or three Ariciidæ, and in some Alciopidæ.

In Polychæts, as in Crustaceans and Molluscs, there are two kinds of otocysts:—(1) those remaining in communication with the exterior by a ciliated canal, and enclosing otoliths composed of foreign bodies (small grains of quartz); (2) those which are completely closed, and enclose spherical otoliths, with concentric layers, of an organic nature, and secreted by the organ. In these closed otocysts there may be one otolith or several.

The otoliths are moved by the play of vibratile cilia, except in *Arenicola grubii* and *A. ecaudata* where cilia are entirely absent. In the last case there is indeed always movement, but it is a brownian movement. In *Amphitrite edwardsi* there are no otocysts, but small encysted Trematodes have been described as such.

**Notes on Polygordius.**‡—R. P. Cowles notes that larvæ of *Polygordius appendiculatus* are abundant at Woods Hole, Newport, Beaufort,

\* Comptes Rendus, cxxxv. (1902) pp. 784-6. † Tom. cit., pp. 1362-5.

‡ Johns Hopkins Univ. Circ., xxii. (1903) pp. 21-2 (1 pl.).

and along the coast of Virginia, but the adult has not been taken. He reared the larvæ very successfully by the "diatom-method." Sand was obtained by means of a dredge and put into aquarium jars with fresh sea water. The jars were then kept near a window until the sand had settled and a rich culture of diatoms had appeared as a brown layer on the top of the sand. This was drawn off with a pipette and given to the young worms. Under these conditions the young worms grew rapidly and thrived well. By means of the glandular papillæ on the anal segment they attached themselves to the bottom of the dish, but the rest of the body was kept in almost continual motion, waving backwards and forwards and often making knots.

**Alimentary Tract of the Leech.\***—Camille Spiess has studied the gut of *Hirudo medicinalis*, and finds that the pouched stomach or crop is especially adapted for absorption. Its wall consists of two very delicate membranes,—an external connective layer, without glands but with transparent muscle-fibres, and an internal epithelium, in single layer, with numerous longitudinal plaits. This epithelium consists of prismatic cells with markedly reticular cytoplasm, without any membrane at the free surfaces, but distinctly secretory.

#### Nematohelminthes.

**Filaria perstans.†**—G. C. Low discusses the distribution, life-history, and importance of this Nematode, larval forms of which were discovered by Manson in the blood of a West African negro suffering from sleeping sickness. It occurs in British Guiana and West Africa, in or near the equatorial belt. The young forms live in the blood; the adults inhabit the connective tissues at the base of the mesentery. Its intermediate host is quite uncertain, though it is probably some insect. Like *Filaria demarquaii* it gives rise to no pathological symptoms. It is not really connected with sleeping sickness.

#### Platyhelminthes.

**Asiatic Human Parasites.‡**—C. W. Stiles and L. Taylor report on three Asiatic parasites "which may possibly occur in returning American troops,"—an adult cestode (*Diplogonoporus grandis*), a larval cestode (*Sparganum mansonii*), and an Egyptian and Japanese Strongyle (*Strongylus subtilis*). This illustrates a somewhat unusual provision.

**New Gyrocotyle.§**—W. A. Haswell describes from a new species of *Callorhynchus*, described by Waite under the name *C. ogilbyi*, a new species of *Gyrocotyle*, for which the name *G. nigrosetosa* is proposed. The members of the genus *Gyrocotyle* (*Amphiptyches*) are monozoic unsegmented Cestodes (with hexacanth larvæ) found exclusively in Holocephali. It is not surprising, therefore, that a new species of *Callorhynchus* has yielded a new species of *Gyrocotyle*. Haswell com-

\* Arch. Sci. Phys. Nat., xiv. (1902) pp. 548-52.

† Brit. Med. Journ., No. 2204, March 28, 1903, pp. 722-4 (2 figs.).

‡ Bull. U.S. Dep. Agriculture, No. 35, Washington, 1902, pp. 43-7 (7 figs.), 47-56 (8 figs.), 41-2 (1 pl.).

§ Proc. Linn. Soc. N.S.W., xxvii. (1902) pp. 48-54 (1 pl.).

compares the new form with *G. urna* and *G. rugosa*, and has some remarks on the *Gyrocotyle* in general. Thus he shows reason for regarding the sucker end as *anterior*.

**North American Trematodes.\***—H. S. Pratt has published another of the useful synopses of North American Invertebrates. It deals with the digenetic forms,—Aspidocotylea and Malacocotylea, and gives the usual diagnostic keys.

**Sub-Œsophageal Ganglion of Liver-Fluke.†**—E. Mareinowski finds that there are small ganglion-cells around the whole of the pharynx and œsophagus. There is too little concentration or definite localisation to justify such a term as peri-pharyngeal or peri-œsophageal ganglion. A comparison with the sub-œsophageal ganglia of Annelids cannot be more than approximate.

**Peculiar Fluke.‡**—H. L. Osborn describes, as *Cryptogonimus chili* g. et sp. n., a peculiar fluke found in the stomach and intestine of the black bass (*Micropterus dolomieu*) and other fresh-water fishes. The worms appear to the naked eye as extremely minute black spots in the yellowish chyle of the host. The black colour is due to numerous ova in the coils of the uterus at the extreme posterior end. The oral sucker is relatively large, and there are *two* ventral suckers, one directly behind the other, and a little dorsal to it, both in the middle line. The only other Distomid known having two ventral suckers is *Podocotyle fractum* Rud. The genital opening lies between the two suckers, which are contained within a sheath formed as a depression of the ventral surface, and having a lip furnished with a circular sphincter muscle.

#### Incertæ Sedis.

**Re-discovery of Cephalodiscus M'Intosh.§**—K. A. Anderson on the Swedish Antarctic Expedition has been fortunate enough to find in four different localities specimens of this rare animal. It was previously obtained by the 'Challenger' (1876) in the Magellan Straits, and Anderson has the honour of finding it for the second time. It was got off Cape Seymour at 150 metres, south of the Falklands at 197 metres, at the Burdwoodbank at 150 metres, and in the Beagle Channel at 80–235 metres. In each of these four dredgings several colonies were got. It seems to be rather local than very rare. Some small larvæ were seen, in a planula-like stage. The animal seems to have its reproductive period in spring.

#### Echinoderma.

**Antarctic Echinoderms.||**—F. Jeffrey Bell reports on a collection made during the voyage of the 'Southern Cross.' He establishes two new genera of Ophiuroids,—*Ophiosteira*, with five large keel-like plates on the dorsal surface of the disc, each interposed between two radial

\* Amer. Natural., xxxvi. (1902) pp. 953–71 (130 figs.).

† Jenaische Zeitschr. f. Naturwiss., xxxvii. (1903) pp. 544–50 (1 pl.).

‡ Zool. Anzeig., xxvi. (1903) pp. 315–8 (2 figs.). § Tom. cit., pp. 368–9.

|| Rep. Collections in Antarctic Regions during Voyage of 'Southern Cross,' London, 1902, pp. 214–20 (3 pls.). See Zool. Centralbl., x. (1903) p. 73.

shields, and *Ophionotus*, differing from *Ophioglypha* in the larger number of arm-plates, and in the absence of incisions and spine-combs over the bases of the arms. An interesting series of variations in *Cytherea simplex* is noted.

#### Cœlentera.

**Spermatogenesis in Hydra and Aurelia.\***—W. M. Aders describes the development of the testes in *Hydra viridis* from accumulations of sub-epithelial "indifferent" cells, which are not at first distinguishable from indifferent elements which occur elsewhere. There is no histological evidence of a distinction between somatic and primitive germ-cells. The cells forming the primordium of the simple testis multiply and grow, and may soon be called spermatogonia. Their nuclei seem distinctly larger than those of the other sub-epithelial cells, and their plasma stains more darkly and intensely. As multiplication proceeds two generations of spermatocytes may be distinguished; they differ in size, but the author was not able to count the chromosomes. He follows the spermatocytes onwards to spermatids and spermatozoa.

In the male gonads of *Aurelia aurita*, Aders found certain large cells in the ripe follicles among the sperm-forming cells. It seems that these are separated off from the endoderm, that they migrate into the testes, and that they serve as nutritive cells for the seminal elements.

**Cœlentera from Intermediate Waters of North Atlantic.†**—R. T. Günther reports on a collection obtained by Mr. George Murray during the cruise of the 'Oceana' in 1898. Especially noteworthy is a Leptomedusoid *Laodice chapmani* sp. n., differing from other species in the character and distribution of the gonads, and an Anthomedusoid *Bythotiarra murrayi* g. et sp. n.—a Tiarid with four radial canals, which bifurcate and open into the circular canal by eight adradial terminal branches, and with four gonads arranged interradially along the manubrium.

#### Porifera.

**Ingestion of Food-Particles in Sycandra raphanus.‡**—J. Cotte fed this sponge with carmin and carbon particles, rice-starch, and bacteria. The collar-cells or choanocytes were seen to form pseudopodium-like processes on their apical surface, and with these they engulfed the particles which the flagellum swept towards them. In short, an amœboid mode of ingestion is confirmed.

**Metabolism in Sponges.§**—J. Cotte finds that the nitrogenous disassimilation-products of *Suberites domuncula* are wholly or partially amides.

The juice of the same sponge turns brown on exposure to air. This is due to tyrosinase, a tyrosin-forming ferment. Tyrosin is not formed in the living sponge, but is produced by the digestive ferments

\* Zeitschr. f. wiss. Zool., lxxiv. (1903) pp. 81-108 (2 pls. and 8 figs.).

† Ann. Nat. Hist., xi. (1903) pp. 420-30 (2 pls.).

‡ C.R. Soc. Biol. Paris, liv. (1902) pp. 1315-7. See Zool. Centralbl., x. (1903) p. 177.

§ C.R. Soc. Biol. Paris, liv. (1902) pp. 1317-8; lv. (1903) pp. 137-9, 139-41. See Zool. Centralbl., x. (1903) pp. 177-8.



from albuminoid components of the sponge or of its juice. A tyrosin ferment also occurs in *Donatia (Tethya) lycurium* and *Geodia cydonium (Cydonium gigas)*.

Cotte also notes the presence of small quantities of manganese in *Reniera* and *Suberites*, and of iron in *Donatia (Tethya)* and *Suberites*. The occurrence of iron in *Spongilla* is denied.

**Indian Triaxonia.**\*—F. E. Schulze gives in his usual fine style an account of the Indian *Triaxonia* collected by the 'Investigator.' The memoir has been expertly translated by R. von Lendenfeld, and the plates are of great excellence.

#### Protozoa.

**Nuclear Emissions in Protozoa.**†—A. Conte and C. Vaney have studied *Opalina intestinalis* Ehrbg., from the intestine of *Triton teniatus*, which exhibits in its cytoplasm numerous granules like the multiple nuclei described in *Opalina ranarum* Ehrbg.

The nucleus is primitively single and very large, oval in form, and bounded by a very distinct nuclear membrane. In some it doubles, but in most the nuclear membrane disappears over a certain area, and through this opening numerous chromatin granulations escape into the cytoplasm. The history of these emissions is described; it corresponds generally to that of zymogen granules in the glandular intestinal cells of the newt.

Probably the vitelline nuclei in the ova of insects, myriopods, vertebrates, &c. are of a similar nature,—pseudo-nuclei, simply nuclear emissions. The authors' researches lead them to conclude that the nucleus participates directly in forming granules of zymogen and ergastoplasmic products. It has therefore an important rôle in digestion, whether intra-cellular or extra-cellular.

**New Rhizopod.**‡—E. Penard gives a preliminary description of *Clathrella foreli* g. et sp. n., a new Rhizopod from the Lake of Geneva. It has some resemblances to *Thecamœbæ* and others to Heliozoa. The cell is surrounded by delicate flexible siliceous cupules, compressed by mutual pressure. Where the pieces join, there radiate out long, filiform, often bifurcate or ramified pseudopodia, like those of *Euglyphina*. The food consists chiefly of diatoms, ingested by the temporary separation of pieces of the envelope. The nucleus is exceptionally large, the plasma includes several large contractile vacuoles. Young forms were seen, with six cupules forming a regular cubical capsule.

**Nuclear Division of Amœba.**§—P. A. Dangeard notes that there is considerable diversity in the mode of nuclear division in species of *Amœba*; thus among those which exhibit "teleomitosis" some are characterised by the disappearance of the nucleolus at the prophase, while in others the nucleolus separates into two halves, one persisting at each pole of the spindle until the anaphase. In *Amœba gleichenii* the telomitosis does not differ appreciably from what is seen in the cells

\* Publications of the Indian Museum, Calcutta, 4to, 113 pp. and 23 pls.

† Comptes Rendus, cxxxv. (1902) pp. 1365-6.

‡ Arch. Sci. Phys. Nat., xiv. (1902) p. 554.

§ Comptes Rendus, cxxxv. (1902) pp. 1126-8.

of higher organisms. It is in this respect a prototype of what occurs in Metazoa.

**Foraminifera of Raised Reefs of Fiji.\***—R. L. Sherlock has studied the composition of the raised limestone terraces, and finds that they consist chiefly of Algæ and Foraminifera. Although a few of the rock-sections are composed of coral, and corals are present in some others, yet in the majority they are absent. The organisms found comprise fifteen certain and seven doubtful genera of Foraminifera (including the genus *Orbitoides*, which indicates Tertiary age), besides algæ, corals, echinoderms, molluscs, Tunicata, Polyzoa, and an occasional annelid.

**Adaptability of Marine Infusorians to Fresh Water.†**—P. Enriques reports on a number of experiments which show great diversity in this adaptability. Thus *Euplotes charon* and *Chilodon cucullulus*, which occur in both salt and fresh water, survive the change from the former to the latter, but *Euplotes harpa*, which is wholly marine, does not. As the two species of *Euplotes* do not differ in osmotic properties or in permeability, the reason of the difference in their surviving power when changed from salt to fresh water must depend on peculiarities of chemical metabolism.

**Fossil Infusorians.‡**—B. Renault describes from the Eocene lignites of l'Hérault what seem to be fossil Infusorians. They occur in the pollen-chambers of *Stephanospermum*, and belong to the family Keroninæ, forms without cuirass. The absence of styles and cornicles points to affinity with the genus *Cinetoconia* Ren. Some evidence is given suggesting that they attacked and fed upon the pollen-grains.

**Flagellate Parasites in Siphonophora.§**—Fr. Poche describes from the internal cavities of *Cucubalus kochii*, *Halistemma tergestinum*, *Monophyes gracilis*, &c. two Flagellate parasites:—*Trypanosoma grobbeni* sp. n. and *Ozyrrhis parasitica* sp. n. A detailed account is given of both.

**Structure of *Trepomonas agilis* Dujardin.||**—P. A. Dangeard finds that this much-studied Flagellate Infusorian has a twin structure. It is a double-cell, a peculiarity seen also in the allied genera of the family Distomatineæ. He compares the organism to the Siamese-twins, but the duplication is normal and hereditary. He proposes the general term "*Diplozoïd*," and the systematic name Diplomonadineæ, to cover this and similar cases.

In *Trepomonas* the duplication may be primitive, or it may be due to an incomplete fusion of two individuals. In any case the duplication is transmitted to the progeny. A comparison with *Amœba binucleata* is suggested. In other Diplozoïds the duplication may be effected afresh in each generation.

[If the duplication be strictly heritable, it surely cannot be due to

\* Bull. Mus. Zool. Harvard, xxxviii. (1903) pp. 349-65 (13 figs.).

† Atti R. Accad. Lincei (Rend.), xii. (1903) pp. 82-8.

‡ Comptes Rendus, cxxxv. (1902) pp. 1064-6 (3 figs.).

§ Arbeit. Zool. Inst. Univ. Wien, xiv. (1903) pp. 307-58 (1 pl.).

|| Comptes Rendus, cxxxv. (1902) pp. 1366-7.

an incomplete fusion of two individuals. Here the author's argument seems to us somewhat unsatisfactory.]

**Trypanosomiasis.\***—Patrick Manson suggests that the infecting agent in this disease may be the poisonous tick—*Ornithodoros (Argas) moubata* of the Zambesi valley. A. Maxwell-Adams, junr.,† suggests that the rat is the intermediate host, and that the original seat of the parasite is some insect (*Pulex?*) peculiar to, and living only on the juices of the rat. He believes in inoculation from rat-bite. If the infection were due to ticks or mosquitos one would expect greater frequency.

**Nature of *Cytoryctes vaccinæ*.‡**—Anna Foà discusses the nature of the vaccine and variola corpuscles which have been regarded by some as Sporozoa, by others as Staphylococci, by others as modified leucocytes, fragments of cells, &c. The conclusion come to is that the corpuscles in question are not living parasites; they are without nucleus, chromatin, amoeboid movement, or power of multiplication.

In a subsequent paper § further observations on the so-called *Cytoryctes vaccinæ* are described, the possibility of the corpuscles being Protozoa or parasites of any kind is definitely excluded, though the possibility of parasites being present is not of course denied.

**Cœlomic Gregarine in a Beetle.||**—L. F. Blanchard describes *Monocystis legeri* sp. n., which occurs in encysted and vegetative stages in the general cavity of the body of *Carabus auratus*. The only other cases of "cœlomic" Gregarines in beetles are those reported by Léger in larvæ of *Oryctes nasicornis* and *Geotrupes stercorarius* where the cysts of an intestinal Gregarine protrude on the external surface of the intestine into the cavity of the body. In Blanchard's case there is also an intestinal Gregarine—*Ancyrophora gracilis* Léger.

**Hæmogregarines of Ophidia.¶**—A. Laveran describes new species of *Hæmogregarina* from the blood of *Naja tripudians*, *Zamenis hippocrepis*, *Crotalus confluentus*, and *Ancistrodon piscivorus*, raising the number of Ophidian hosts of Hæmogregarines to thirty-two. No forms in process of multiplication were seen in the blood, as is also true of Chelonians. In the latter the multiplication occurs in the liver, &c., and Laveran found stages in the lung of *Eumectes murinus*. He thinks it likely that infection is due to ectoparasites, e.g. *Ixodes*.

\* Brit. Med. Journ., No. 2204, March 28, 1903, pp. 720-1.

† Tom. cit., pp. 721-2.

‡ Atti R. Accad. Lincei (Rend.), xii. (1903) pp. 64-71.

§ Tom. cit., pp. 88-93.

|| Comptes Rendus, cxxxv. (1902) pp. 1123-4.

¶ Tom. cit., pp. 1036-40 (13 figs.).



## BOTANY.

## GENERAL,

## Including the Anatomy and Physiology of Seed Plants.

## Cytology,

## including Cell-Contents.

**Protoplasmic Streaming.\***—Dr. Ewart's work on protoplasmic streaming embodies the results of a series of observations carried on during eight years.

The author concludes that the energy of movement is generated in the moving layers themselves, which are retarded by friction against the non-moving ectoplasm, and also, but to a much less extent, by friction against the cell-sap. The velocity of streaming is largely dependent upon the viscosity of the protoplasm, and therefore also upon the percentage of water in the latter, but osmotic pressure has little or no direct influence upon the process. Gravity does not affect the streaming in small cells and only to a very slight extent in the case of large cells; but may affect the velocity of floating particles of greater or less density than the plasma. A calculation of the amount of work done indicates that the energy expended in streaming is only a very small fraction of that produced by respiration. The force required increases enormously as the diameter of the channel decreases, so that transference in mass of the highly viscous ectoplasm through interprotoplasmic connections becomes practically impossible. The relations between streaming, growth, and assimilation are indirect; and similarly the influence of the nucleus is an indirect one. The minimal, optimal, and maximal temperatures for the process vary with the plant or cell examined, and also depend upon (1) the age or condition of the subject of experiment, (2) the external medium, (3) the duration of the exposure, (4) the supply of oxygen, and (5) the rapidity with which the temperature is raised or lowered. Strong light retards streaming, while weak light may indirectly accelerate the process in chlorophyll-containing cells. Acids, alkalis, and metallic poisons all retard the process and may cause a temporary shock-stoppage when suddenly applied. Dilute alcohols and anaesthetics and weak electrical currents may accelerate the process; more concentrated solutions and strong currents retard it. The chloroplasts have no active power of movement, but are carried passively in the stream.

As regards the source of energy, surface-tension seems the only kind of energy capable of producing the streaming movements under the existing conditions in plant-cells; this is probably brought into play by the action of electric currents traversing the moving layers, and maintained by chemical action in the substance of the protoplasm. These electric currents may be supposed to act upon regularly arranged bipolar

\* Alfred J. Ewart, 'On the Physics and Physiology of Protoplasmic Streaming in Plants,' Oxford, 1903, viii. and 131 pp. and 17 figs.

particles of protoplasm in such a way as to lower the surface-tension on the anterior faces and raise it on the posterior ones.

There is an appendix on the electrical conductivity of egg-albumin.

**Distribution of Spherulin among Plant Families.\***—L. Petit finds that the refringent globules which he discovered in the chlorophyll parenchyma of the leaves of many members of the gamopetalous and epigynous polypetalous families of dicotyledons are very rare in what he terms the lower families, namely, apetalous dicotyledons and monocotyledons. He indicates a reaction by means of which spherulin may be recognised. If sections be treated successively with eau de Javelle, iodine tincture, and finally glycerin, the globules become coloured chestnut-brown.

### Structure and Development.

#### Vegetative.

**Stelar System in Flowering Plants.†**—J. C. Schoute has studied the morphology of the stelar system in the seed-plants. In the first part of his work the author describes his investigations on the structure of the stem- and root-apex in a number of angiosperms and concludes that Hanstein's meristematic layers—dermatogen, periblem, and plerome—do not correspond to the division of the adult tissues into epidermis, cortex, and central cylinder as proposed by Van Tieghem and others. Moreover, he finds that there is too much inconstancy in the cell-wall reticulum of the growing apex, especially of the stem, for it to be regarded as of much value as a clue to the morphology of the tissues.

In the second part of his work the author gives the results of his examination of the stems of a large number of angiosperms for the presence of an endodermis or phlocoeterma. He finds, in opposition to Fischer, that an endodermis is a very constant feature of the stem in monocotyledons, occurring in eighteen out of nineteen families investigated. In the dicotyledons it was present only in 99 out of 169 families. The author concludes that the endodermis is a layer of great morphological importance. On consideration of the recent work on the ontogeny of the central cylinder he agrees with Boodle, that the central cylinder of all vascular plants is morphologically the same, that is, monostelic.

**Intermediate Wood.‡**—P. Vuillemin suggests this term for the wood formations which either by their origin, or their position, or the order of succession depart from the classic idea of primary and secondary. The term comprehends Van Tieghem's metaxylem, or vessels developed in the conjunctive tissue of the root between the wood-rays and the phloem area, belonging to the primary wood but agreeing with the secondary wood in position and orientation. It includes also the case now described by the author in the root of *Gentiana ciliata* where the cells of the pericycle near the protoxylem form wood-elements at the same time that the secondary wood-formation begins in the conjunctive tissue on the inner side of the phloem.

\* Comptes Rendus, cxxxv. (1902) pp. 991-2. See this Journal for 1902, p. 194.

† J. C. Schoute, 'Die Stelar-Theorie,' Proefschrift, Groningen, December 1902. See E. C. Jeffrey in Bot. Gaz., xxxv. (1903) pp. 144-5.

‡ Comptes Rendus, cxxxv. (1902) pp. 1367-9.

**Anatomy and Movements of *Porliera hygrometrica*.**\*—A. Rodrigue gives the results of his study of this member of the order Zygomphyllaceæ. The young leaves and those on the principal stem show incomplete movements; the other leaves show an oblique movement of the rachis followed by an oblique but slower movement of the leaflets. The movements vary from day to day with the intensity of direct sunlight; the movements cannot be induced. *Porliera* sleeps from 6 p.m. to 8 a.m. and often also in the middle of the day. The existence of a palisade layer on both faces of the leaf allows assimilation to take place during the midday sleep.

A considerable development of collenchyma was found in all the motile parts. The movement curves are explained (*a*) by furrows and ridges in the cortex of the leaf-base; these are especially developed on one side; (*b*) by the very ellipsoidal form of the bundles, especially at the articulation of the leaflets where the cortex is divided into two parts which have no direct communication. The course of the bundles is almost identical in the leaves of the motile Leguminosæ, Oxalidæ, and *Porliera*. No motor swellings occur, there is no local concentration of the bundles or exaggeration of the cortex. Chemical tests do not show the presence of tannin; its absence suggests that it may perhaps not play the important part which has been assigned to it in the Leguminosæ. Nor were plasmic threads found between the cells; their absence is not surprising as transmission of stimuli does not occur.

#### Reproductive.

**Embryogeny of *Zamia*.**†—J. M. Coulter and C. J. Chamberlain describe the results of their study on the embryogeny of *Zamia floridana*. They note that the ovulate cones continue their development for some time after removal from the plant. The nucleus of the ventral canal-cell is formed, but no definite cell is cut off; the protuberance in which the nucleus lies rapidly disorganises. Their preparations of the fertilisation stages confirm Webber's account. A period of free nuclear division follows fertilisation; the mitotic figures of the eighth division, which gives rise to the 256-nucleate stage, were counted. The nuclei are scattered through the egg; there is no tendency to form the large central vacuole and consequent parietal placing of the nuclei as in *Cycas*; the nuclei are more numerous in the lower part of the proembryo, but the upper portion is never free from nuclei in the later stages, and it would seem probable that many of the nuclei in the upper part of the proembryo which is not to form any part of the embryo proper, are due to irregular division. Thus *Zamia* differs from *Cycas* in the absence of the central vacuole and the parietal arrangement of the nuclei. It also differs in the formation of cell-walls, which are restricted to rather a limited area at the base of the egg. The elongating cells of the suspensor can be distinguished at quite an early stage from those of the embryo proper. The rapid elongation of the suspensor forces the embryo down into the endosperm. Owing to the great resistance the base of the embryo is forced upward into the

\* Biblioth. Univers. Arch. Sci. Phys. et Nat. (Geneva), sér. 4, xiv. (1902) pp. 513-5.

† Bot. Gaz., xxxv. (1903) pp. 184-93 (4 pls.).

archegonial chamber and is stopped only by the hard seed-coat: the suspensor when straightened out may be 5 cm. long.

In the mature embryo the two cotyledons are free at apex and base, but more or less completely fused in the middle region; the long cotyledons constitute the greater part of the embryo. *Zamia* therefore differs from *Ceratozamia* which, according to Warming, has only one cotyledon formed from part of the meristematic apex of the axis, the rest forming the stem-tip.

The authors suggest a series of gymnosperms from an embryonic point of view. In the first series a gradual reduction in the number of free nuclei is shown. In *Ginkgo*, *Cycas* (?), and *Zamia* eight successive simultaneous nuclear divisions precede wall-formation, resulting in 256 free nuclei. In passing to Coniferales there is a sudden drop in the number of free nuclei and a gradual further diminution. *Taxus* has 32, *Cephalotaxus*, *Podocarpus*, and *Taxodium* 16, *Thuja* 8, and *Pinus* 4, the higher numbers however not being entirely constant. Further reduction occurs among the Gnetales, *Ephedra* sometimes showing only a single free nuclear division resulting in two free nuclei, while in *Gnetum* and *Welwitschia* no free nuclear division occurs at all. These last-named forms have reached the condition of the embryogeny of angiosperms, in which the first division of the egg-nucleus is accompanied by wall-formation.

A second series is based on the manner of wall-formation. At one extremity stands *Ginkgo* with its numerous free nuclei equally distributed, and its wall-formation resulting in a proembryo which completely fills the egg. In *Cycas* there is a massing of nuclei towards the base of the egg, and most of the remaining nuclei pass to the periphery to form the parietal layer. In *Zamia* wall-formation appears only in connection with the basal nuclei, and tissue-formation is restricted to the basal region as in Coniferales. In the latter group there is a gradual reduction in the number of nuclei, and a more definite setting apart of the function of each particular nucleus. Thus in *Zamia* the suspensor cells are not recognisable until they begin to elongate; in *Taxus*, *Cephalotaxus*, *Podocarpus*, and *Taxodium* there is no setting apart of a distinct suspensor-forming layer; while in *Thuja* with its eight nuclei, there is a distinct suspensor-forming layer, as also in the 4-nucleate forms. Thus the embryogeny of *Ginkgo* would be the most primitive among gymnosperms, and that of *Cycas* more primitive than that of *Zamia* which approaches more nearly the Conifers; while such forms as *Taxus*, *Cephalotaxus*, and *Thuja* show progressive stages from *Zamia* towards *Pinus*. *Ephedra* shows the most primitive embryogeny of the Gnetales, while *Gnetum* and *Welwitschia* most resemble the angiosperms.

**Life-History of *Ruppia*.\***—Sv. Murbeck records the following results of his study of *Ruppia rostellata*. He suggests that pollination may occur under water as well as on the surface, though definite proof was not obtained. During the development of the microspores the

\* K. Svensk. Vetensk. Akad. Handl., xxxvi. (1902) pp. 1-21 (3 pls.). See also Bot. Gaz., xxxv. (1903) pp. 228-9.

tapetal cells break down and their nuclei float free in the liquid which fills the cavity of the microsporangium. Two definite male cells are formed within the irregularly elongated pollen-grain. In the macrosporangium the archesporial cell forms a tapetal cell and a megaspore mother-cell; the latter gives rise to four megaspores, the two upper of which lie side by side, while the two lower stand in vertical series. In the mitosis by which the archesporial cell forms the tapetal cell and the megaspore-mother-cell the number of chromosomes was sixteen, and the same number was found in other sporophytic cells. In the first division of the megaspore-mother-cell and in the microspore-mother-cell the number is eight.

The polar nuclei fuse completely before fertilisation. The pollen-tubes were traced to the embryo-sac, but the process of fertilisation was not observed. At the first division of the endosperm-nucleus a wall is formed dividing the sac into an upper and a lower chamber; in the lower (antipodal) chamber, which is the smaller, the nucleus does not divide, but in the other chamber a large number of free nuclei are formed. The author confirms Wille's statement that a primary root is formed at the base of the embryo, but soon disorganises, and a lateral root which is formed very early is the first functional one. This differs from the account given by Ascherson in the *Pflanzenfamilien*, according to which this lateral root is the primary root, its unusual position being due to displacement.

**Development of Macrosporangium of *Yucca*.**\*—H. S. Reed gives the results of his study of this phase in the life-history of *Y. filamentosa*. An apical hypodermal cell divides periclinally to form a primary tapetal cell and a sporogenous cell; the former divides by two antielinal walls at right angles to each other forming four tapetal cells, closely resembling the reproductive cells in size, contents, and staining qualities. The sporogenous cell forms an axial row of four potential megaspores, frequently the walls between the upper two are parallel with the long axis of the ovule, so that there are two megaspores *side by side* immediately beneath the tapetal cells. Three of the cells of the megaspore-row disintegrate, the one which becomes permanent was in every case apparently the lowest but one. As it enlarges, the walls of the sister-cells break down and their contents are absorbed, leaving the megaspore in a long pointed cavity in the middle of the nucellus. The germination of the megaspore follows the usual course; by the time the sexual nuclei are formed the tapetal-cells and part of the nucellus have disintegrated, leaving the apical end of the embryo-sac in contact with the epidermis of the macrosporangium. At the basal end a narrow haustorium is formed, extending through the nucellus nearly to the vascular bundle, the division of the nuclei in the germination of the spore takes place in this tube; after completion, the egg-cell and synergids move to the apical end of the sac, and the definitive nucleus also moves out, but the antipodal nuclei usually remain in the tube. A mucilaginous secretion is emitted by the columnar epidermal cells of the placenta and the basal part of the funicle a short time before fertilisation. This

\* Bot. Gaz., xxxv. (1903) pp. 209-14 (5 figs. in text).



recalls Guignard's observation on the tulip, and Campbell's reference to secreting cells in the funicle of *Najas*. This secretion probably serves as a medium through which the substance capable of attracting pollen-tubes diffuses outward from the micropyle. The egg-cell is fertilised shortly after the formation of the secretion, after which there is no further secretion.

**Embryogeny of *Ficus hirta*.**\*—M. Treub describes the pollination of the female flowers of *Ficus hirta* by the gall-insect. The winged females carry pollen into the female receptacle after forcing the narrow entrance and often losing wings or antennæ in the passage. In their efforts to pierce the summit of the female flower in order to deposit their eggs therein, they carry pollen to the stigma. Treub carefully studied the development of the ovule and finds two integuments and a normal embryo-sac; but an examination of more than two thousand sections failed to show more than the beginning of germination of the pollen; the tube was never found in the deeper part of the stigmas, and there was no indication of fertilisation of the egg. As a normal embryo develops from the egg, the author concludes that it is produced parthenogenetically. The ovule shows two anatomical peculiarities, which, while increasing the difficulty of fertilisation, render parthenogenesis very probable. The micropyle is obliterated by fusion of the edges of the internal integument, and the epidermis of the nucellus becomes strongly thickened, forming a compact cap above the embryo-sac. The secondary nucleus of the embryo-sac on division shows only a distant resemblance to karyokinetic stages, dividing with great rapidity by reduced or abridged mitosis. This is explained by the absence of the stimulus of the fusion of the male nucleus. This anomaly affords an indirect proof of the parthenogenetic origin of the embryo. We must regard the puncture by the insect as a special stimulus to parthenogenesis.

**Chalazogamy in *Carya olivæformis*.**†—F. H. Billings finds the course of the pollen-tube in this species to resemble that described by Nawaschin in the walnut. The general morphological character of the ovary-wall and ovule resembles that described for *Juglans* by the Russian observer. The placenta nearly fills the lower part of the ovary-cavity, forming the tissue through which the pollen-tube travels to the base of the ovule. The pollen-tube passes down the conducting tissue of the style, till near the ovary-cavity, where it turns and passes down the ovary-wall close to the margin of the cavity. The tissue through which it travels consists of isodiametric cells, and does not in any way suggest a conducting tissue. At a point a little below the funicle the tube curves, passes through a region of deeply staining cells (as though mucilaginous), and turns upwards towards the embryo-sac. The tube seems to branch as was described in *Juglans*. A micropylar canal is present, but no pollen-tubes were found entering it.

**Biology of Fruit in *Malvaceæ*.**‡—B. P. G. Hochreutiner describes the extreme variability of the fruit in *Malvaceæ*, and of the mechanism

\* Biblioth. Univers. Arch. Sci. Phys. et Nat. (Geneva), sér. 4, xiv. (1902) pp. 496-8.

† Bot. Gaz., xxxv. (1903) pp. 134-5 (fig. in text).

‡ Biblioth. Univers. Arch. Sci. Phys. et Nat., tom. cit., pp. 516-7.

for seed-dispersion. The calyx may open and close hygroscopically like certain capsules; the calyx or the carpels may be bladderly, or the involucre, calyx, or carpels may be accrescent to facilitate flight. Wings may be developed on the calyx or on the carpels. Berries occur, and in one case a fleshy calyx. Jerking and clinging mechanisms also occur in the order.

The author believes that the primitive form of fruit in the Malvaceæ much resembled that of *Abutilon*. In the course of evolution there occurred on the one hand a tendency towards reduction and fixation of the number of carpels, which remained dehiscent, and on the other a tendency towards reduction of the number of seeds in each carpel, producing eventually an achene.

**Floral Structure of Juglandæ.\***—Th. Nicoloff considers that the male flower of *Juglans regia* is formed on a tetramerous plan, having a perianth of four parts and a pair of bracteoles. A study of the pollen-sac development in *Carya amara* shows that the sporogenous cell only becomes differentiated (by size and richness of contents) after several tangential divisions of the hypodermal cell, so that it is separated from the epidermis by four cell-layers. This is not in accordance with the course of development indicated by Warming, in which the sporogenous tissue becomes differentiated after the first tangential division of the sub-epidermal cell.

The female flower of *Juglans regia* is formed on the same plan as the male. M. Nicoloff, from a study of the course of the vascular bundles, comes to a result different from that arrived at by Van Tieghem who assumed that each ovary contained theoretically four ovules.

In the nucellus of *Juglans*, two more or less distinct regions were found. One, in the micropylar region, consists of cells which are fairly large and slightly elongated. They are arranged in radiating lines diverging from the base of the embryo-sac. The lower part of the nucellus consists of a central axis of cells which are much longer than broad, and with a somewhat denser protoplasmic cell-content than that of the peripheral layers.

It is not possible to make out an archesporium, owing to the complete transition between the parenchyma of different parts of the nucellus. The embryo-sac has two synergids towards the micropylar region. Very rarely two embryo-sacs occur in the same nucellus.

The development of the cotyledons and the seed-coat (on which stomata occur) is briefly described.

### Physiology.<sup>1</sup>

#### Nutrition and Growth.

**Photosynthesis outside the Plant.**†—L. Macchiati describes further researches which confirm his previous statement that chlorophyll-assimilation in plants is the result of the action of an enzyme. A glycerin-extract was prepared from leaves washed in distilled water. The ferment was dissolved in benzine and precipitated by evaporation of the benzine

\* Op. cit., pp. 520-4.

† Comptes Rendus, cxxxv. (1902) pp. 1128-9. See this Journal for 1902, p. 72.

as a white flocculent amorphous powder. Other leaves of the same plant were dried at  $100^{\circ}\text{C}$ ., and from the fine green powder prepared from them the enzyme was also extracted by glycerin in the same manner as with the fresh leaf. If the powder be placed in distilled water, evolution of oxygen accompanied by formation of formic aldehyde was observed. The green powder freed from the ferment was unable to effect photosynthesis, but this action was manifested immediately on addition of a small quantity of the ferment. The amount of gas evolved was proportional to the intensity of the light-rays to which the solution was exposed. The author contends that his researches prove undoubtedly that the principal agent of chlorophyll-assimilation in the green plant, and of photosynthesis outside the organism, is a soluble enzyme, and that the chlorophyll pigment apparently functions as a chemical sensitiser.

**Ripening of Seeds and Power of Germination.\***—P. Mazé finds that unripe seeds which will not germinate properly when taken from the plant, will acquire the power to germinate if they are more or less rapidly dried. Seeds of pea and maize, collected when still soft and milky, were placed in tubes containing distilled water. When placed on a stove at  $30^{\circ}\text{C}$ ., the maize developed seedlings which grew vigorously, but a large number of the peas refused to germinate, while in the majority of those that did germinate, the radicle was unable to pierce the seed-coat. If, however, the seeds were previously dried at  $30^{\circ}\text{C}$ . in contact with air over concentrated sulphuric acid for 24 to 48 hours, the maize germinated in the same way as would perfectly ripe seeds, while the peas also yielded normal plants.

**Effects of Water and Aqueous Solutions on Foliage Leaves.†**—J. B. Dandeno after giving a historical *résumé* of work by previous observers on the vexed question of water-absorption by leaves, describes a large series of experiments made by himself on this and kindred subjects. His results and conclusions are as follows:—Wilted leaves, whether detached from the plant or not, will absorb water if immersed, or if water be applied to the surface in the form of spray. Special parts of leaves of certain plants seem to be adapted to the purpose of absorption, as shown by the surface of the epidermal cells over the veins (as in *Ampelopsis*), at the base of the hairs (as in *Primula*) and elsewhere. Hairs in some cases are very susceptible to the action of water and of solutions. Striations and hairs aid in spreading liquids over the regions which seem to be adapted for absorption, and trichomes also prevent a rapid evaporation of the liquid thus spread. Absorption of water may also take place through the surface of the petiole. Guttation drops and dewdrops contain dissolved substances which are generally absorbed by the plant. Carbonates as incrustations may serve to store up carbon dioxide, in the presence of moisture at night, which may be utilised as the bicarbonate is reduced to carbonate in the day-time. Incrustations may be, therefore, not only an adaptation to retain water, but also to utilise to the full the loss of  $\text{CO}_2$  by respiration.

\* Comptes Rendus, cxxxv. (1902) pp. 1130-2.

† Trans. Canadian Inst., vii. pt. 2 (1902) pp. 237-350 (2 pls. and 15 figs. in text).

Distilled water generally becomes alkaline if allowed to remain upon leaves. Certain plants adapted to a moist climate may be made to take in all the food necessary for growth through the leaves. Distilled water used as a spray acts for a time as a stimulus to growth; it may be that it acts as a means of drawing from the plant surplus alkaline salts which might become harmful if formed in too large quantity in the cells. Rain-water may act as a stimulus in this way.

Solutions, if applied to the surfaces of detached leaves, or to leaves upon the plant, are generally absorbed, as shown by the increased content of the ash. Solutions thus applied often stimulate part of the tissue to an abnormal development. Solutions applied to the cut ends of leaf-stalks are generally carried to the minute endings of the tracheides where they kill the tissue either by drawing water from the cells into the intercellular spaces, producing a translucent appearance of the tissue, or by chemical action upon the walls of the cells, the protoplasmic membrane or the protoplasm as a whole. The first determinable reaction after death is alkaline even though the tissue be killed by an acid.

The lithium test gives rise to error because the water ascends faster than the lithium, and because the rate of ascent in the same leaf varies as the length of the vein.

A detached leaf is a living thing which may continue its functions, to some extent, for several months after being detached from the plant.

The food required by woody branches of *Salix* in the early growth of spring is water, at this stage a nutrient solution was harmful. Water and nutrient solutions are apparently absorbed through the buds.

Since sea-water affects the atmosphere in such a way as to produce an accumulation of rust upon iron greater than that produced in an atmosphere under the influence of pure water, it is reasonable to conclude that the atmosphere in the neighbourhood of the sea may affect plants.

**Formic Aldehyde as a Food-stuff for Fresh-water Algæ.\***—R. Bouilhac finds that formic aldehyde can be used by *Nostoc* and *Anabena* which are cultivated in a nutritive solution and exposed to an intensity of light insufficient to allow of their decomposing carbon dioxide; the plants are thus obliged to obtain their carbohydrate food-stuff from an organic source.

A certain intensity of light is necessary to allow the *Nostoc* and *Anabena* to polymerise the formic aldehyde, and the minimum intensity is very near that which is required for the assimilation of the carbon dioxide of the atmosphere.

#### Irritability.

**Influence of Light and Darkness on Plant-life.†**—D. T. Macdougall gives the results of experimental work extending over seven years and including observations on a large variety of plants. These were cultivated in continuous darkness, control plants having been grown under conditions otherwise the same, but in ordinary alternation of light and darkness. The subjects of experiment include aquatics, creepers, climbers,

\* Comptes Rendus, cxxxv. (1902) pp. 1369-71.

† Mem. New York Bot. Garden, ii. (1903) xiii. and 319 pp., 176 figs.

succulent plants, mycorrhizal forms, geophilous and aerial shoots, mesophytes and spiny xerophytes; and the plants were grown from tubers, corms, rhizomes, cuttings of leaves and stems, seeds, and spores.

The author gives a useful historical account which includes notices of nearly all of the more important researches bearing upon the subject, from Ray and Hales onward to the beginning of the present century. Then follows a detailed account of his own experiments on nearly one hundred different species. The arrangement is an alphabetical one, under the name of the plant which formed the subject of experiment.

The chapter on "General Considerations" supplies a useful correlation of the results of these experiments, and includes also critical remarks on work of other observers. The remaining pages of the memoir are occupied with several short chapters. "Theories as to the nature of etiolation," is a brief *résumé* of explanations advanced by previous workers. In "Morphogenic influence of light and darkness," the author points out that examination of the facts obtained by absolute etiolations shows that no one of the theories recorded in the preceding section is capable of general application to the behaviour of all plants in darkness. "The phenomena of etiolation rest upon, and consist in the behaviour of the plant consequent upon the absence of the morphogenetic influence of light. Some species show an adaptation to this absence of light, or to the positive influence of darkness, by which the shoots or petioles are elongated in such manner as to constitute an effort to escape from darkness, or to attain illumination." There are also chapters on the "Influence of etiolation upon chemical composition," and "The rate and mode of growth as affected by light and darkness."

#### ! Chemical Changes.

**Decomposition and Regeneration of Albuminoids in Plants.\***—Gabrielle Balicka-Iwanowska finds as a result of a series of experiments with the yellow lupin that the asparagine which is formed during decomposition of albuminoid bodies is a secondary product, acid amides and hexonic bases being the primary products. Also that mineral salts exercise a certain influence on the regeneration of albumin at the expense of the products of its decomposition. Defect of calcium is the most important cause of diminution in the product of albumin. As regards the effect of light on accumulation of asparagine, and its subsequent use for the regeneration of proteids, the author finds that while photosynthesis has an effect on the regeneration of proteids, light itself seems to exercise a direct effect.

**Function of Peroxides in the Living Cell.†**—R. Chodat and A. Bach have studied the toxic action of hydrogen peroxide. Different species of fungi were grown in a nutritive solution, to which variable amounts of hydrogen peroxide were added. The results show that this peroxide is not very toxic, since some species (e.g. *Sterigmatocystis nigra*) will fructify in a 2 p.c. solution. Peroxides occur in plants; they are the so-called *oxydases* of Bertrand and others. The authors, by passing

\* Bull. Int. Acad. Sci. Cracow, Cl. Sci. Math. et Nat., 1903, pp. 9-32.

† Biblioth. Univers. Arch. Sci. Phys. et Nat., sér. 4, xiv. (1902) pp. 510-2.

a current of air through the juice of plants of *Lathræa Squamaria*, were able to precipitate by baryta solutions an oxydase which has also the properties of the peroxides, notably that of freeing iodine from potassic iodide. M. Chodat has also isolated from *Russula fætens* a ferment which behaves at once like an oxydase and a peroxide. The reactions of the peroxides can be obtained with the fresh plants; the authors experimented with a large number, the most active were *Monstera deliciosa* and *Silphium perforatum*. The characteristic reaction was also obtained in the living cells of the potato, without injury to the cell; the iodine which is set free combines at once with the starch and is thus put out of the sphere of action.

The authors also isolated *peroxydases* which stimulate the action of the oxydases. Catalases are produced by plants to decompose the peroxides which when present in sufficient quantity are injurious.

#### General.

**Plants of Catalonia.\***—A list of the flowering plants of Catalonia with notes on distribution, critical remarks, and descriptions of new species and varieties, from material left by the late Sr. Vayreda. The death of the author interrupted the production of a more detailed flora.

**African Flora XXIV.†**—Includes the following papers:—African grasses III. by R. Pilger, containing a discussion of the relation between the section *Ptychophyllum* of the genus *Panicum* and its relation to the genus *Setaria*. The author regards *Setaria* as forming with *Ptychophyllum* a section of *Panicum*. He also describes new species of *Panicum* and allied genera. African orchids VII. by F. Kränzlin; descriptions of a number of new species in various genera. African Dichapetalaceæ II. by A. Engler and W. Ruhland; descriptions of a number of new species of *Dichapetalum*. African Lentibulariaceæ by F. Kamienski, notes on distribution and description of new species. African Moraceæ II. by A. Engler, description of new species. African Urticaceæ, by A. Engler, description of new species in various genera. African Violaceæ by A. Engler, including notes on the systematic subdivision of *Rinosea* and description of new species. African Passifloraceæ by H. Harms; description of a new genus *Schlechterina* and new species of *Tryphostemma* and *Adenia*. African Leguminosæ by H. Harms, description of new species. African Acanthaceæ VI. by G. Lindau, description of new species. African Dilleniaceæ by E. Gilg, a revision of the African species of *Tetracera*.

### CRYPTOGAMS.

#### Pteridophyta.

**Morphology of Spore-producing Members: General Comparisons and Conclusion.‡**—F. O. Bower in a concluding memoir (No. V.) gives a general discussion of the results acquired in the four previous parts,

\* Anales Soc. Españ. Hist. Nat., ser. ii. x. (Dec. 31, 1902) pp. 491-582 (3 pls.).

† Engl. Bot. Jahrb., xxxiii. (1902) pp. 1-208.

‡ Proc. Roy. Soc., lxxi. (1903) pp. 258-64.

and of their bearing on a theory of sterilisation in the sporophyte. The author concludes that all that remains as the fundamental conception of the sporangium in vascular plants is the spore-mother-cell or cells and the tissue which covers them in. The definition of the sporangium may be given thus : " Wherever we find in vascular plants a single spore-mother-cell, or connected group of them, or their products, this with its protective tissues constitutes the essential of an individual sporangium." From the point of view of a theory of sterilisation such sporangia may be regarded as islands of fertile tissue which have retained their spore-producing character, while the surrounding tissues have been diverted to other uses.

The methods of variation in the number of sporangia are tabulated under the heads of progressive increase and decrease ; the condition of any polysporangiate sporophyte is the resultant of such modifications operating during its descent. In homosporous types, which are the more primitive, the larger the number of spores the better the chance of survival, and hence, other things being equal, increasing numbers of spores and sporangia may be anticipated ; but in heterosporous types reduction in number both of spores and sporangia is frequent. Homosporous forms are therefore regarded as in the upgrade of their evolution as regards their spore-producing organs, unless there is clear evidence to the contrary. The evidence of variation in numbers of sporangia in the great groups of Pteridophytes leads to the result that all of them are referable to modifications of a radial strobiloid type. A comparison is drawn between the fertile zone in certain Bryophytes and the fertile region of Lycopods. In the Bryophytes the fertile region is regarded as a residuum from progressive sterilisation, and it is suggested that similar causes would lead to decentralisation of the fertile tissue in the primitive Pteridophytes and result in the formation of a central sterile tract with an archesporium at its periphery. Such an archesporium became discrete in the Lycopods ; the fertile cell-groups formed the centres of projecting sporangia and were associated regularly with outgrowths which are the sporophylls. Whether or not this hypothesis of the origin of a Lycopod strobilus approaches the truth, comparison points out the genus *Lycopodium* as a primitive one, characterised by more definite numerical and topographical relation of the sporangia to the sporophylls than in any other type of pteridophyte.

The sporangiophore, including the sori of ferns, are placental growths and not the result of metamorphosis of any parts or appendages of prior existence ; it is probable that a plurality of sporangia existed on primitive sporangiophores. The Lycopods, Psilotaceae, Sphenophylleae, and Ophioglossaceae may be arranged as illustrating the increased complexity of the spore-producing parts and of the subtending sporophylls ; the factors of the advance from the simple sporangium to the more complex sporangiophore are, septation, upgrowth of the placenta with vascular supply into it, and branching, with apical growth also in the Ophioglossaceae. In *Equisetum* the sporangia are regarded as directly seated on the axis and therefore non-foliar ; this brings the genus into accord with the fossil Calamariaceae. The ferns are strobiloid forms with greatly enlarged leaves. The Lycopods, Psilotaceae, Sphenophylleae, Ophioglossaceae, and Filices

illustrate lines of elaboration of a radial strobiloid type with increasing size of leaf.

The author holds Celakovsky's opinion that the Lycopods are probably the nearest living prototypes of the Ophioglossaceæ. The latter in conjunction with their more pronounced megaphyllous form still retaining the lycopodinous type of the sporophyte, show more pronounced filicinean characters of the gametophyte and of the sexual organs. The meaning of this parallelism between leaf-size and characters of the sexual organs is not obvious; in the Equiseta it does not hold; these filicinean characters of the gametophyte accompany entirely non-filicinean characters of the sporophyte, the latter showing nearer analogy to the Lycopods. Such cross characters are difficult to harmonise with any phylogenetic theory; hence the Equisetineæ are placed in an isolated position.

The following grouping is suggested:—

Pteridophyta.

I. LYCOPODIALES.

(a) *Eligulate*—Lycopodiaceæ.

(b) *Ligulate*—Selaginellaceæ, Lepidodendraceæ, Sigillariaceæ, Isoetaceæ.

II. SPHENOPHYLLALES.

Psilotaceæ, Sphenophyllaceæ.

III. OPHIOGLOSSALES.

Ophioglossaceæ.

IV. FILICALES.

(a) *Simplices*—Marattiaceæ, Osmundaceæ, Schizæaceæ, Gleicheniaceæ, Matonineæ.

(b) *Gradate*—Loxsomaceæ, Hymenophyllaceæ, Cyathaceæ, Dicksoniæ, Dennstædtiineæ, Hydropterideæ (?)

(c) *Miata*—Davalliæ, Lindsayæ, Pterideæ, and other Polypodiaceæ.

V. EQUISETALES.

Equisetaceæ, Calamariæ.

The actual connection of these series by descent must remain an open question; it is possible that some or all of them may have originated along distinct lines from a general primitive group, which may be provisionally designated the Protopteridophyta. These were probably small-leaved strobiloid forms, with radial type of construction, and with the sporangia disposed on some simple plan.

**Botrychium.**\*—L. M. Underwood publishes an annotated index of the known species of *Botrychium* containing 35 valid species and a variety; and of these there are 6 that are described as new species, and a seventh that is raised from varietal to specific rank. The synonymy and distribution of each species are given.

**Spore-cavity Nucleus in Prothallia of Marsilia.**†—W. C. Coker has studied the behaviour in *M. Drummondii* of the nucleus left with

\* Bull. Torre Bot. Club, xxx. (1903) pp. 42-55 (1 pl.).

† Bot. Gaz., xxxv. (1903) pp. 137-8 (figs. in text).



the food-material in the cavity of the megaspore on the formation of the prothallium. It enlarges greatly as development proceeds, retaining its position beneath the prothallium, and at time of fertilisation is much larger than the nuclei of the remaining tissue, and the shape, which varies considerably, is peculiar. It shows long arms and fine extensions radiating towards the prothallium. As development proceeds it fragments amitotically; the reticulum is throughout very dense, and a nucleolus is present. If the radiating processes are normal, as seems probable, they recall the filaments extending from the nucleus into the food-mass in the egg-cells of *Dytiscus* (see Wilson, *The Cell*, p. 115). In the case of *Marsilia*, however, the processes extend towards the tissue to be nourished instead of towards the food-material. The nucleus is doubtless concerned with the elaboration or transference of food-material.

**Opening Mechanism of the Macrosporangia of Selaginella.\***—S. Schwendener maintains that the dehiscence of the sporangia is due, at any rate in part, to the hygroscopic action of a row of thin-walled cells on the keels of the sporangia. In his opinion Steinbrinck † errs in regarding a “cohesion mechanism” as the only possible cause; whether it plays any part in the process must be at present left undecided.

#### Bryophyta.

**Formation of Antherozoids in Marchantia. ‡**—S. Ikeno gives a summary describing the behaviour of the centrosomes during the cell-division that occurs in the formation of the antherozoids in *Marchantia polymorpha*, and the relation of the centrosomes to the cilia of the antherozoids. The blepharoplasts of the Vascular Cryptogams and Gymnosperms are, he thinks, to be regarded as centrosomes.

**Culture of Hepatics.§**—W. Benecke has experimented with the development of the gemmæ of *Lunularia cruciata* when sown on nutrient solutions of various constitutions, and has noted the effect of the presence or absence of various salts, such as nitrates and phosphates, upon the young plants. When cultivated in pure distilled water, the plants barely produce any rhizoids; they require the presence of chemical stimulants, whether nutrient or otherwise, for normal germination. The effect of the presence or absence of light upon the cultures is described. The behaviour of these gemmæ is compared with that of germinating plants of *Riccia fluitans* and of the higher plants. The formulæ of the solutions employed, the modifications introduced, and the consequent results, are detailed.

**Scapania.||**—C. Massalongo has made a study of the Italian species of the genus *Scapania*, paying special attention to the many intermediate and transitional forms which render so difficult any attempt to make a satisfactory delimitation of the species. He recognises twenty

\* S.B. K. Preuss Akad. Wiss. Berlin, xlvii. (1902) pp. 1056-9 (2 figs. in text).

† See this Journal, 1902, p. 459.

‡ Comptes Rendus. cxxxvi. (1903) pp. 628-9.

§ Bot. Zeitschr., 1903, pp. 19-46 (6 figs. in text).

|| Malpighia, xvi. (1902) pp. 393-438.

species and eight varieties as valid and, having arranged them in groups, describes them in detail, giving the full distribution in Italy and adding critical notes on the allied species that occur in the rest of Europe. An analytical key and an index are supplied.

**Papillate Hepatics.\***—I. Douin remarks upon the rarity of papillæ in hepatics, and distinguishes the different forms of papillæ met with in the group. He discusses the specific value of three species of *Cephalozia* with papillate leaves, and proposes a scheme of classification for them, and adds critical notes upon some other species of *Cephalozia* and *Lepidozia*, and upon *Jungermannia exsectiformis* as compared with *J. exsecta*.

The same author † gives a list of six mosses and nine hepatics hastily gathered between the gushes of the intermittent spring of Fontestorbes near Bélesta (Ariège) on the north side of the Pyrenees.

**Fossombronina.‡**—L. Corbière describes a new species, *Fossombronina Crozalsii*, gathered by A. Crozals in the south of France, and distinguishes it from *F. angulosa* and *F. Dumortieri* to which it is allied in the markings of its spores. And he adds some notes upon the distribution of the genus in France.

**German Hepatics and Sphagna.§**—C. Warnstorf completes his account of the hepatics and Sphagnaceæ of Mark Brandenburg, the whole cryptogamic flora of which is in course of publication by several specialists. He describes the species carefully and amply, distinguishes the varieties, and adds critical notes. To the tribes and genera he appends analytical keys. The numerous figures are a valuable feature of the work.

**Italian Hepatics.||**—E. Barsali publishes a list of the hepatics that are found on Monte Pisano and in the neighbourhood of Pisa, giving localities and the principal synonyms. There are 67 species in all, eleven of which are new to the district. The introduction contains an account of the geographical distribution in the district and of the various substrata selected by several groups of species.

C. Massalongo ¶ transcribes the descriptions of two European species of *Scapania* which, as he has recently ascertained, occur also in Italy. They had previously been found only in Scandinavia and the eastern Alps.

**American Hepatics.\*\***—C. C. Haynes records the discovery near Prospect Harbour, Maine, of *Cephalozia Francisci* Dum., for the first time in America. Originally described from Norfolk by Hooker, the species is rare in Europe. At the same locality in Maine were found a few other rare hepatics.

**Lejeunea in North America.††**—W. C. Barbour describes the ten species of this genus that occur in the North-eastern United States,

\* Rev. Bryol., xxx. (1903) pp. 2-12 (figs. in text).

† Tom. cit., pp. 12-13. ‡ Tom. cit., pp. 13-5 (figs. in text).

§ 'Leber- und Torfmoose,' Leipzig, 1903, xv. and 481 pp. and 231 figs.

|| Nuov. Giorn. Bot. Ital., x. (1903) pp. 55-78.

¶ Bull. Soc. Bot. Ital., 1902, pp. 138-40. \*\* Torrey, iii. (1903) pp. 40-41.

†† Bryologist, vi. (1903) pp. 27-32 (figs. in text).

adding a simplified key to them, and figuring six of the species. The chief synonyms, the habitats, and distribution are given.

**Hepaticæ of Puerto Rico.\***—A. W. Evans describes in full and figures ten species of *Drepanolejeunea* gathered by himself and others in Puerto Rico. Four of the species are new. Historical, distributional, and structural notes on the genus are added.

**Two Egg-Cells in Mnium.†**—W. C. Coker finds in an undetermined species of *Mnium* an archegonium which contained two well-developed egg-cells of normal appearance. The extra one lay directly over the other. In each case a ventral canal-cell had been cut off. The writer suggests that the upper egg had been derived from the lower neck canal-cell.

**British Mosses.‡**—R. Braithwaite publishes the penultimate part of his British Moss-Flora, and describes 23 species and figures 26. Three of these form the completion of the genus *Stereodon*; and the residue are divided up among nine genera. Four of these genera are Hypnaceous; three are Pterygophyllaceous; and the remaining two belong to the Neckeraceæ.

**Yorkshire Muscineæ.§**—W. Ingham has compiled a complete list of all the mosses and hepatics that have been gathered hitherto in the East Riding of Yorkshire, together with their habitats and the collectors' names. He records 228 mosses and 55 hepatics with numerous varieties and forms.

**Riccioarpus natans.||**—J. E. Bagnall records the occurrence of this rare hepatic at Berkswell in Warwickshire, where it was found in abundance by S. P. Bolton. It appears to have been gathered at only seven other localities in Great Britain, but is less rare in Ireland.

**French Volcanic Muscineæ.¶**—A. Crozals has investigated the peculiar moss-flora of Roquehaute (Hérault), a small volcanic district on the shores of the Mediterranean, and publishes a list of 74 mosses and 26 hepatics. Among the latter are 13 species of *Riccia*, also *Riella Battandieri* and the rare *Dichiton perpusillum*, previously known only from Algeria. The two latter species have probably been imported by migratory birds. Half the mosses noted are of the Pottiaceous type, and no strictly calcicolous species are found.

**European Mosses.\*\***—Th. Herzog publishes lists of the mosses gathered by him in the course of 1901-2 in the Black Forest and the Alps of Switzerland, Tyrol, and Bavaria, mostly at new localities. There are three lists containing a total of 101 species.

**German Mosses.††**—J. Roll publishes a list of 19 species of *Sphagnum*, subdivided into 80 varieties and very numerous forms, gathered

\* Bull. Torrey Bot. Club, xxx. (1903) pp. 19-41 (6 pls.).

† Bot. Gaz., xxxv. (1903) pp. 136-7 (fig. in text).

‡ 'British Moss Flora,' part xxii. 1903, pp. 169-200 (6 pls.).

§ Journ. Bot., xli. (1903) pp. 115-126. || Tom. cit., p. 139.

¶ Rev. Bryol., xxx. (1903) pp. 17-32.

\*\* Bull. Herb. Boissier, iii. (1903) pp. 149-54

†† Hedwigia, xlii. (1903) Beiblatt, pp. 24-8.

by him on one day at two localities in the neighbourhood of the Milseburg in the Rhöngebirge. This list is of the nature of an appendix to the 222 mosses recorded by A. Geheeb in his paper 'Die Milseburg im Rhöngebirge und ihre Moosflora' (*Festschrift des Rhönclubs*, 1901).

L. Loeske \* publishes a handbook to the mosses and hepatics of the Harz Mountains, adding many species to the list contained in E. Hampe's *Flora Hercynica* (1873). The book consists of an introduction, keys to the genera and species, critical and distributional remarks on the species, and a bibliography.

W. Mönkemeyer † calls attention to the rich moss-flora of the Fichtelgebirge, which though studied a century ago by H. C. Funck and later by Laurer and by Molendo was far from exhaustively examined, especially as regards the hepatics; and he publishes a preliminary list of 24 hepatics and 62 mosses, of which 7 and 14 respectively are new to the district.

The same author ‡ gives a list of 127 mosses and 13 hepatics and numerous varieties gathered in the Wesergebirge.

F. Matouschek § describes a new variety of the widely distributed *Pylaisia polyantha* with crispate leaves, analogous to the crisped form of *Leucodon sciuroides* described by him last year.

**Austrian Muscineæ.**||—F. Matouschek has examined the collections of Breidler and others, and drawn up a localised list of 161 mosses and 62 hepatics gathered in Moravia and Austrian Sillesia. There are no new species.

**Italian Mosses.**¶—A. Bottini publishes a list of the acrocarpous mosses gathered in the Tuscan Archipelago by Béguinot, Sommier, and Marcucci at various times in the past thirty years, and recently worked up by himself. Some six varieties are new to science; one species is new to Italy and 40 are new to the Archipelago, while the mosses of Pianosa and Montecristo are recorded for the first time. The promontory of Monte Argentario is regarded as belonging to the archipelago rather than to the mainland.

**North American Mosses.\*\***—N. C. Kindberg insists upon the importance of a close comparison of the moss-floras of Europe and North America. Several examples are cited of species which, though regarded as exclusively American, have turned out to be identical with European species; and again of species which are sterile or rare in Europe and in America are found to be fertile or common respectively. And amid some further critical remarks he introduces descriptions of three new species of *Bryum* and one of *Orthotrichum*—all from North America.

**Mosses of Alaska.**††—J. Cardot and I. Theriot give the bryological results of the Harriman Alaska Expedition—a list of 280 species, in-

\* 'Moosflora des Harzes,' Leipzig, 1903, xx. and 350 pp.

† Hedwigia, xlii. (1903) pp. 67-72.

‡ Tom. cit., pp. 89-95. § Tom. cit., v. 99.

|| Verh. naturf. Verein in Brünn, xl. (1902) pp. 65-83.

¶ Bull. Soc. Bot. Ital., 1902, pp. 175-86.

\*\* Hedwigia, xlii. (1903) Beiblatt, pp. 14-17. †

†† Proc. Washington Acad. Sci., iv. (1902) pp. 294-374 (11 pls.).

cluding 124 new to Alaska and 46 new to science, viz. 29 new species and 17 new varieties. In this list are included the results of previous collectors.

J. M. Holzinger\* in summarising the above announces that the number of species now known from Alaska and the Bering Sea Islands reaches 350, without reckoning a number of doubtful species.

**Inconspicuous Mosses.**†—J. M. Holzinger describes the haunts of some of the minute mosses (*Archidium*, *Phuscum*, &c.) that occur in the upper Mississippi valley, which he has had under observation for several years. They wither away soon after the snow has melted.

**Psilopilum.**‡—R. S. Williams publishes a critical note on the difference between *P. tschutschicum* and *P. arcticum* as illustrated by specimens gathered in the Yukon and Klondike region by himself and by Macoun, and concludes that the two species are sufficiently distinct.

**Mosses of East Greenland.**§—P. Dusén has worked up the mosses collected by the Swedish Expedition under A. G. Nathorst to East Greenland and Jan Mayen Island in 1899. The gatherings were far from exhaustive; hence the number of species enumerated does not exceed 130. Hurry Inlet was the richest locality visited, but the expedition made only a very short stay there. Five new species of *Bryum* are described. The climate is a dry one; and the conditions of drainage, of irrigation by melting snow, of soil, &c. which affect the moss vegetation, are discussed. The special gatherings from the fourteen chief localities visited are noted separately, and are followed by a general systematic enumeration of the whole collection. An index is supplied and a map of the voyage.

**The Moss Exchange Club** || issues its report for 1903. The principal feature is a list of the mosses and hepatics contributed by the members for exchange. Critical remarks by the referees upon several of the specimens are added.

**K. G. Limpricht.**¶—V. Schiffner supplies a biography of the late K. G. Limpricht, the distinguished German bryologist, who died at Breslau last October in his sixty-ninth year, and who for many years was lecturer in Natural Science at an Evangelical College in Breslau. His high qualities as a systematist and biologist in the study of the European Muscinæ are pointed out; and a chronological list of his publications—66 in number—is appended. The greatest of these—*Die Laubmoose Deutschlands, Oesterreichs und der Schweiz*—a well-known standard work on mosses in three volumes, is still incomplete. It was begun in 1885; and the lapse of time since the first part appeared has necessitated the preparation of a supplement which is being issued by the author's son.

J. M. Holzinger\*\* gives a short account of the life of Limpricht

\* Bryologist, vi. (1903) pp. 35-6.

† Tom. cit., pp. 37-8.

‡ Tom. cit., p. 38.

§ Bihang K. Svensk. Vet.-Akad. Handl., xxvii. iii. No. 1, pp. 71 (4 pls. and 7 figs. in text). || Moss Exchange Club, Report for year 1903, pp. 127-50.

¶ Hedwigia, xlii. (1900) Beiblatt, pp. 1-6 (with portrait).

\*\* Bryologist, vi. (1903) pp. 33-5.

based upon data obtained from German friends of the deceased bryologist; and adds a list of his three principal works and thirty-eight shorter papers on Muscineæ.

### Thallophyta.

#### Algæ.

**British Fresh-water Algæ.\***—Messrs. W. and G. S. West publish a list of 94 fresh-water algæ from various parts of England, including thirty from the Scilly Islands, the first records from that part. Three new genera are described, *Phæosphæra*, *Pseudochæte*, and *Polychætophora*, containing one new species each, and, excluding these, the authors describe also other ten new species. Of these the most interesting is *Debarya desmidioides*, which forms another link in the descent of the Desmidiaceæ from the Conjugatæ. It is an extremely fragile plant, the filaments of which break up most readily into individual cells, and conjugation only takes place between two of these isolated cells. The authors consider that the origin of the genera *Mesotanium* and *Cylindrocystis* from ancestral filamentous Conjugatæ is clearly indicated by this new species. Amended and enlarged descriptions are given of the genera *Chlorobotrys* and *Ineffugiata*.

**Fresh-water Algæ.†**—A. Hansgirg publishes some additional notes on fresh-water algæ which he has collected in Bohemia, giving the localities in which he found them. Some of these records are here brought together and republished from other papers. Then follows a list of species collected by the author in the East Indies, specimens of which will be distributed in Beck's *Kryptogamie exsiccata* and in Richter's *Phycotheca universalis*. The locality where each species was found is given, and in many cases notes regarding size, &c. are added.

Finally, remarks are made on the fresh-water algæ of Greece and Egypt, founded on collections made by the author in those countries.

**Literature on the Algal Flora of Russia.‡**—An alphabetical list of authors on this subject, with a short *résumé* of the work of each, is published by N. Gaidukow, and a short chronological treatment of the literature is added.

**Fresh-water Algæ of the Azores.§**—K. Bohlin has made a study of the fresh-water algæ of these islands and has himself found 158 species, which together with other records makes a total of 171 species known from the Azores. His collections were however limited for the most part to one island, they took place during only one season, and that included the driest months of the year, June to August. Consequently this list is not considered by the author as being in any way exhaustive, though he believes that even further investigation will show that the fresh-water flora of the Azores is a poor one. The physical geography of the islands is briefly described, and general remarks are made on the various habitats of fresh-water algæ, lacustrine, thermal,

\* Journ. of Bot., xli. (1903) pp. 33-41, 74-82 (3 pls.).

† S.B. k. böhm. Gesell. Wissensch., xxviii. (1902) 17 pp.

‡ Script. Bot., xvii. (1901) pp. 1-123.

§ Bihang k. Svensk. Vet.-Akad. Handl., xxvii. (1902) No. 4, 85 pp. (1 pl.).

and others, and summaries are given of any previous algal literature on the district. The general character and occurrence of the algological vegetation is dealt with at some length, and among other interesting facts it may be noted that certain common genera of Desmids are conspicuously absent, notably those containing species of a large size. Various suggestions are offered to explain the geographical distribution of the flora, which is quite European. As regards the systematic part of this paper, certain novelties are published, and critical notes are appended to many of the species-names.

**Plankton of Lake Nyasa.\***—W. Schmidle describes the plankton (Chlorophyceæ and Cyanophyceæ) of this tropical African lake.

**Fresh-water Algæ from Zambesi.†**—N. Wille has examined a collection of fresh-water Algæ from this part and publishes a list of 36 species, of which eight are diatoms and one is a species of *Nitella*. The novelties are *Placoma africanum*, a new form, *africana*, of *Anabena variabilis* Kütz., and *Eupodiscus lacustris*. Both new species are figured.

**Desmids from Bridgewater (Mass.).‡**—J. A. Cushman records 66 species of Desmids from Carver's Pond, Bridgewater, Massachusetts. The pond covers 42 acres. After each name is a statement as to the frequency or rarity of the species.

**North American Marine Algæ.§**—F. S. Collins publishes a much-needed account of the Ulvaceæ of North America, in which the four genera *Ulva*, *Monostroma*, *Enteromorpha*, and *Ilea* are described, including together 33 species and 26 varieties. Keys to the genera and species are given, and critical notes are appended to the diagnoses. As regards references to previous literature, these are mostly confined to the works of American authors; and specimens in the principal American exsiccatae are referred to by number. Three plates, containing forty-six figures, show the microscopic structure of many of the species.

The same author describes an algological holiday in Eastern Maine, giving the habitats of certain species and recording the occurrence of *Plectonema Battersii* and *Porphyra amplissima*, both new to New England. Interesting details of several species are given.

**Fresh-water Algæ from South Patagonia.||**—O. Borge enumerates about 150 species of fresh-water algæ from this region, which is by no means rich in species. This is probably owing to the salt nature of the soil in many parts, the many salt lagoons, and the salt water of many of the streams. Several of the common genera of Desmids are here not represented at all, while *Euastrum* and *Pleurotanium* have respectively only three and one species each. A short list is given of the plankton of a lake and a lagoon. The main part of the paper consists of the list of fresh-water algæ found, with the number or numbers

\* Engl. Bot. Jahrb., xxxiii. (1902) p. 1.

† Oester. Bot. Zeitschr., liii. (1903) pp. 89-95 (5 figs. in text).

‡ Rhodora, v. (1903) pp. 79-81.

§ Tom. cit., pp. 1-31; op. cit., iv. (1902) pp. 174-9.

|| Bihang k. Svensk. Vet.-Akad. Handl., xxvii. (1902) No. 10, 49 pp. (2 pls.).

appended to each name, under which the specimens may be found in the Natural History Museum at Stockholm. Several novelties are described.

**Cultivation of *Chlorella vulgaris*.**\*—J. Grintzesco has succeeded in isolating this alga and growing it in various media, and he describes here his experiments and the results. After a short introduction, he gives a *résumé* of the previous work on *Chlorella* and a list of the papers which he has consulted. Then he deals with the habitat of the species and the best means of isolating it for purposes of cultivation. The development of the alga is described under the headings of "General appearance," "Membrane, chromatophore, pyrenoid, nucleus," and "Division." The second part of the paper details the experiments made in various media, with the formula of each, and the following are the results:—(1) Agar- or gelatin-media, prepared with inorganic substances, form good cultivating media for *Chlorella vulgaris*. (2) Glucose always stimulates the development of this alga and its action is not harmful, even if the cultures are prolonged for some time. (3) In media which contain no glucose, *C. vulgaris* shows a tendency to develop at the surface of the substratum; in media containing glucose development takes place equally throughout all parts of the substratum. (4) Peptone is not a better source of nitrogen than are nitrates. (5) *C. vulgaris* does not liquefy gelatinous media.

Grown on porous plates the alga develops more slowly than in agar cultures; in ordinary sterilised water the development is fairly rapid, and if nutritive salts are added growth increases proportionately within a certain limit.

As regards light, it was found that the direct rays of the sun are unfavourable, but in electric light the alga grows well and rapidly. In total darkness development takes place more quickly than in full daylight.

The maximum and minimum of temperature which allow of growth in *C. vulgaris* are respectively 35° C. and 1·8° C. In vacuum-tubes development is retarded, the colonies being invisible until the twentieth day.

A comparative table of the physiology of *Scenedesmus acutus* and *Chlorella vulgaris*, followed by remarks on the polymorphism of these algæ, complete this paper, which is illustrated by six text figures.

**Cell-membrane of Desmidiaceæ.**†—J. Lütkemüller has made a detailed study of the genera of Desmidiaceæ with the exception of four genera, and on the strength of his results he divides the family into five groups. These are called the (1) Cosmarium type, (2) Closterium type, (3) Penium type, (4) Gonatozygon type, (5) Spirotænia type. These groups are founded entirely on characters connected with the cell-membrane, which in certain types consists of two layers and has an apparatus of pores. The variation in form and position of these pores, when present, constitutes characters in the new systematic treat-

\* Rev. Gén. Bot., xv. (1903) pp. 5-19, 67-82.

† Beitr. z. Biolog. d. Pflanz., viii. (1902) pp. 347-414 (3 pls.). See also Bot. Centralbl., xcii. (1903) pp. 256-60.



ment laid down by the author, as also do the manner of cell-division and the periodicity in the complete development of a species. Comparisons are drawn between the various types, and a sketch of the new system founded on these characters is given. The method of examination consisted in emptying the cell of a fresh Desmid of its contents by means of pressure, then of staining the different elements of the membrane with water-solutions of fuchsin, methyl-violet, and Bismarck-brown, and finally clearing the preparation with acetic acid.

**Dichotomosiphon tuberosus.**\*—Under this name A. Ernst describes a new fresh-water alga allied to *Vaucheria*, which possesses, like that genus, oogonia and antheridia. It also shows a form of non-sexual reproduction hitherto unknown among Siphoneæ. Towards the end of the vegetative period elongated swollen bodies are formed at the ends of the rhizoids. These bodies are filled with a dense protoplasm and contain chlorophyll and starch. They become divided off from the plant by a transverse wall, and in about two months new filaments arise from any part of their surface. The author refers to *Vaucheria tuberosa* Kützing as being identical with his plant, but he maintains that it is more nearly allied to *Colium*, *Halimeda*, and *Udotea* than to *Vaucheria*, on account of the dichotomous branching and the internal thickening of the membrane in places.

**Bryopsis plumosa.**†—E. Perceval Wright has cultivated this species and found that in certain cases the lowermost pinnae gave rise to rhizoids and then dropped off, growing as independent plants. Some dropped off having no rhizoids, and formed long, irregular, siphonaceous growths resembling *Vaucheria*. Sometimes the protoplasm took the appearance of oogonia, but no sort of reproduction was seen. The plants then died from attacks of minute parasitic algæ.

**Mastogloia fimbriata** and **M. binotata.**‡—E. Perceval Wright publishes notes by Dr. Dixon on the periglæa and the tentaculoids of these two species. A comparison between them shows certain differences in the minute structure. A short account is given of previous work on the subject, as well as the geographical distribution of four species of *Mastogloia* (*Orthoneis*).

**Macrocystis pyrifera.**§—C. Skottsberg gives some notes on this alga concerning its manner of growth, habitat, length, and the depth at which it grows. He criticises statements made by J. D. Hooker in the *Flora Antarctica* as to the length of a single plant, considering that the alga is not so long, nor does it grow from such great depth as is there described.

**Eisenia** and **Ecklonia.**||—K. Yendo has made a study of *Eisenia arborea* Aresch. and of *Ecklonia bicyclis* Kjellm. He considers that *E. bicyclis* is merely a form of *Eisenia arborea*, and names it *E. arborea* forma *bicyclis* Yendo.

\* Arch. Sci. Phys. Nat. Geneva, xiv. (1902) pp. 506-10.

† Notes Bot. School Trin. Coll. Dublin, 1902, pp. 174-5 (pl. ix. figs. E, F).

‡ Tom. cit., pp. 161-5 (pl. ix. figs. A-D).

§ Bot. Notis., 1903, pp. 40-4.

|| Bot. Mag. Tokyo, xvi. (1902) pp. 203-6 (figs. A, B).

**Vegetative Reproduction in *Chondria crassicaulis*.**\*—K. Okamura has found and examined knob-like ramelli which are produced on the apices of ramuli in this alga. They are elongato-obovate or ellipsoidal in shape and grow 5-7 or more on the same apex. Their general structure is the same as that of the main thallus, except that the cells are more compact, roundish, and rich in contents. The layer of cells which divides the epidermis from the central axis is very rich in globular starch. The neck, which connects the knob with the thallus, is composed of very loose tissue, and the knob is thus easily detached. The author has found slight prominences on the surface of the knobs, which, as seen in longitudinal section, are composed of elongated cells filled with protoplasm. These prominences he regards as the beginning of root-hairs. The paper ends with remarks on the systematic position of *Chondria crassicaulis* Harv., which should be ranked, in the author's opinion, among the tribe Chondriæ Macrocarpæ.

**Fresh-water Diatoms.**†—A. Forti publishes a tabulated list of 178 diatoms collected in Friuli and the Eastern Alps. These collections were made in 23 different localities, either on the banks of lakes or at varying depths in them. Notes are given respecting the geography or geology of some of these lakes, as well as remarks on the occurrence of certain species in the various samples.

The same author gives a list of 41 species found in the lakes of Lagorai and Stellune in Trentino. Of these, the most uncommon are *Suriraya Capronii* Bréb., *Meridion constrictum* Ralfs, *Eunotia tetraodon* Ehr., *Pinnularia Legumen* Ehr., *Suriraya calcarata* Nitz., and *Ceratoneis Arcus* Ehr.

**Diatoms of Koh Chang.**‡—A list is published of the marine plankton diatoms of this district by C. H. Ostenfeld, and one of the fresh-water diatoms by E. Oestrup. New species are described in both papers. The marine collection was obtained from the surface of the sea in the inner part of the Gulf of Siam. The fresh-water forms were found in pools, river-beds, rice-fields, and inland waterfalls. It is interesting to find certain marine forms recorded from both the rice-fields and the inland waterfalls. Their presence in the rice-fields is accounted for by the proximity of these shallow fields to the sea-coast, but it is more difficult to explain the appearance of *Achnanthes baccata* in inland waterfalls.

**Blue Diatom.**§—H. Molisch records the occurrence of the blue diatom, *Navicula ostrearia*, on the shells of *Pinna nobilis* L., at the zoological station in Trieste. It had been previously recorded by E. Ray Lankester from Marennes on the Normandy coast, growing on *Ostrea edulis*, and the blue-green colour of the oysters and of the diatom has been made a subject of speculation by zoologists. Carazzi is of opinion that both organisms absorb certain material from the surrounding water and thus form the colour for themselves. The blue colour is confined to the two ends of the diatom, and is said by Professor Lankester to

\* Bot. Mag. Tokyo, xvii. (1903) pp. 1-5.

† Att. R. Ist. Ven., lxii. (1902-3) pt. 2, pp. 285-321.

‡ Bot. Tidsk., xxv. (1902) pp. 1-41 (23 figs. in text).

§ Ber. Deutsch. Bot. Gesell., xxi. (1903) pp. 23-6 (1 pl.).

occur in the protoplasm, not in the vacuoles. Further investigation on this point is much needed, as the author, through lack of material, was unable to complete his investigations.

**Classification of Diatoms.\***—C. Mereschkowsky criticises the old method of classification and maintains that the Diatomaceæ should be divided into two groups, Mobiles and Immobiles. The most important character as a basis for classification is the presence or absence of an opening in the walls of the frustule. Only those diatoms which possess this opening are endowed with a power of movement, and these are placed by the author in the group Mobiles. This group is divided primarily into Raphidicæ and Carinatae, both of which are again subdivided. Immobiles is divided into Bacilloideæ and Anaraphideæ. Details are given as to the genera included in the divisions.

**Polynesian Diatoms.†**—The same author gives a list of species of diatoms from Samoa, Tahiti, and the Hawaiian Islands, including some new species and varieties. The contents of a slide made from specimens obtained in a deep sounding in the Pacific are also enumerated. Though the exact locality of this sounding is doubtful, the author considers it to have been probably off the Californian coast north of San Francisco. Critical notes are appended to many of the records, and the paper is illustrated by 3 plates.

**Germination of certain Florideæ.‡**—F. Tobler gives the result of his observations on the germination from the spore, of marine algæ belonging to the genera *Ceramium*, *Callithamnion*, *Dasya*, and *Dudresnaya*. His object was to discover whether in any of these genera there was any trace of protonema or prothallus stage, which would explain their apparent disappearance during certain seasons of the year at Naples. He finds however nothing which can be regarded as a prothallus, and the plant arising directly from the germinating spore bears a great resemblance to the thallus of the mature plant. The difficulties attending a study of this kind are naturally great, both as regards isolating the spores for cultivation and in keeping the culture pure.

A summary is given of previous literature on the subject.

### Fungi.

**Taphridium, a New Genus of Protomycetes.§**—H. O. Juel has constituted this new genus for the reception of two parasitic fungi, one of which had been originally described as *Taphrina Umbelliferarum*, one of the Exoasceæ. He and Lagerheim simultaneously examined these fungi and decided that they were akin to the Protomycetes rather than the Ascomycetes. The so-called asci or sporangia are intercalary on the hyphæ, and from the first are multinucleate. He describes in great detail the different stages in the formation of the sporangia, and the germination process which resembles that of *Protomyces*. *Taphridium* differs from *Protomyces* in the formation of both vegetative and repro-

\* Script. Bot., xviii. (1900-2) pp. 87-98. † Tom. cit., pp. 99-164 (3 pls.).

‡ Beih. z. Bot. Centralbl., xiv. (1903) pp. 1-12 (1 pl.).

§ Bihang K. Svensk. Vet.-Akad. Handl., xxvii. pt. 3, No. 16, 29 pp. (1 pl. and 8 figs. in text).

ductive hyphæ, the latter being localised under the epidermis. The writer discusses fully the question of relationship between the Protomyces and the Ascomycetes. They are both derived from the same ancestral form which probably possessed sexual organs and also non-sexual or conidial forms, and it is from the conidial forms that the Protomyces have originated.

**Protascus, a New Genus.\***—P. A. Dangeard gives a note on this fungus which is a parasite on Eel-worms and has hitherto been overlooked owing to its resemblance to *Myzocyttium*. When fully developed it has the form of a flask inserted in the body of the worm, the projecting neck bends over and pierces the skin of the worm. Special attention is drawn to the method of sporulation: the sporangium produces non-motile spores corresponding to the number of nuclei formed, 8, 16, or 32. They are club-shaped and are ejected with considerable force. The writer follows the opinion of Brefeld that the ascus is derived from the non-sexual sporangium, and he considers that the life-history of this fungus supports that view. It forms a transition between the Phycomycetes and the Ascomycetes.

**Endogone.†**—P. Baccarini discusses in a lengthy note some of the characters of this genus. He reviews the opinions of previous workers as to its systematic position, and describes particularly these species *E. macrocarpa*, *E. Pampaloniana* sp. n., and *E. lactiflua*. He pays special attention to the formation of the so-called asci which arise at the end of the hyphal branches. The author makes a note on a fossil form of fungus that he found in the "Disodile" and which he described as *Pythites Disodilis* Pamp. He is now of opinion that it was *Endogone macrocarpa*, thus proving the antiquity of the genus. He thinks also that probably the Endogoneæ are an offshoot of a group of Oophycomyces not unlike the existing *Pythium*.

**Sclerospora.‡**—G. B. Traverso publishes a note on a new variety, *Sclerospora graminicola* var. *Setarie-Italica* which he found attacking *Setaria italica*; the development of the grass was arrested and the leaves were brown or withered. Microscopic examination showed a large number of oospores with a reddish-brown episporium. Conidiophores have not been found either by Traverso or by MacBride and Hitchcock, who record a *Sclerospora* on species of *Setaria* in America. The writer gives a diagnosis of the new variety.

Some additional notes § on *Sclerospora graminicola* are furnished by F. L. Stevens. He notes new hosts and new localities for the parasite.

*Sclerospora macrospora* || has hitherto been found only on *Alopecurus*. G. Cugini and G. B. Traverso record its appearance as a parasite on *Zea Mays*. Its presence in the hosts is shown by the appearance of small transparent spots on the leaves. The disease is as yet unimportant, only few plants having been attacked.

\* Comptes Rendus, cxxxvi. (1903) pp. 627-8.

† Nuovo Giorn. Bot. Ital., x. (1903) pp. 79-92.

‡ Bull. Soc. Bot. Ital., ix. (1902) pp. 168-75.

§ Journ. of Myc., lxx. (1903) p. 13.

|| Stazioni Agrarie Sperimentali, xxxv. (1902) pp. 46-9.

**New Chytridiaceæ.\***—Serbinow describes *Sporophlyctis rostrata*, a new genus and species which grows on the algæ *Draparnaldia* and *Chaetophora*. There is a bladder-like cell provided with a small beak and with a root-like filament, which is often branched. A sporangium is formed later, inside which the spores germinate and pierce the sporangium-wall. Sexual reproduction takes place by the fusion of two individuals, the oospore is surrounded by a spinous membrane.

*Rhabdium acutum*,† also a new member of the Chytridiaceæ, was found by P. A. Dangeard parasitic on filaments of *Spirogyra* and *Eidogonium*. It consists of a short slender tube which projects from the surface of the alga. A disc at or near the base acts as a sucker. The whole plant transforms itself into a zoosporangium, the zoospores numbering about 16. They escape slowly from the extremity of the tube, remain active for a time, then settle down on the host and put out a filament which penetrates the cell-wall, the external part elongates into the tube which in time becomes the sporangium. The writer gave the name *Rhabdium* on account of the rod-like appearance of the mature fungus.

**Disease of Chestnut Trees.‡**—L. Mangin contributes a note as to the cause of a disease that has worked great havoc in the forests of southern France. It is caused by a fungus with extremely fine mycelium that lives as a parasite on the mycorrhiza of the tree and gradually destroys the roots up to the base of the trunk. Usually the hyphæ of the parasite are confined to the mycorrhiza or to the tissue of the root, it is rarely found free in the soil, but occasionally it attacks rhizomorph strands not connected with the chestnut, and it is only on these rhizomorphs that the fructification has been found. The mature form of fructification resembles the oospores of a *Peronospora*, and for this reason the fungus has been classified along with the Oosporeæ as *Mycelophagus Castanea*. A further and more detailed communication in regard to the disease is promised.

**Mucorini.§**—L. Matruchot gives a much longer and more detailed account of *Cunninghamella africana*, than has hitherto been published. It has morphologically the form of an *Edocephalum*, but Matruchot places it among the Mucorini because it serves as host to *Piptocephalis*, a parasite only on *Mucor* or *Pilobolus*.

C. Wehmer || describes a new species *Mucor hiemalis*, the sporangio-phores are usually unbranched, the sporangia small and dark; zygospores were not seen. It grows on hemp.

**Study of Absidia.¶**—Paul Vuillemin passes in review the various known forms of *Absidia*. The genus is characterised by the regular growth of the stolons which form arches at the summits of which the sporangiophore rises. *Absidia repens* deviates from the type in the

\* Reprint from the K. St. Petersburg. Naturforscherges., xxx. See also Centralbl. Bakt., x. (1903) pp. 102-3.

† Comptes Rendus, cxxxvi. (1903) pp. 473-4. See also Ann. Myc., i. (1903) pp. 61-4 (1 pl.).

‡ Comptes Rendus, cxxxvi. (1903) pp. 470-3.

§ Ann. Myc., i. (1903) pp. 45-60 (1 pl.).

|| Tom. cit., pp. 37-41 (7 figs.)

¶ Comptes Rendus, cxxxvi. (1903) pp. 514-6.

irregular form of the stolons, and has been therefore placed in a separate genus *Tieghemella*. Vuillemin supports this view, as he has found another species on the roots of an *Orchis* still more erratic, which he designates as *T. Orchidis*. He proposes a new genus *Proabsidia* for *Mucor Saccardoï*, which has neither stolons nor rhizoids, but which is otherwise closely allied to *Absidia*. *Mucor corymbifer* he places in the same group as type of a new genus *Lichtheimia*. *Mycocladus verticillatus* also becomes a member of the series, which he resumes thus:—(1) *Proabsidia* (*P. Saccardoï*); (2) *Lichtheimia* (*L. corymbifera*); (3) *Mycocladus* (*M. verticillatus*); (4) *Tieghemella* (*T. dubia*, *Orchidis*, *repens*); (5) *Absidia* (*A. septata*, *capillata*, *reflexa*).

**New Discomycetes.\***—P. Hennings describes several new Pezizæ found recently in Germany by himself and others. The diagnoses are accompanied by critical notes.

**Disease of Fir Trees.†**—H. Mayr has made a thorough investigation of a disease of fir trees termed *Schütte*. He proved by infection experiments that it was due to the attack of the parasitic fungus *Lophodermium Pinastris*. It is especially harmful to seedling plants. The needles become infected from May to July. A period of inaction sets in, and it does not spread until May of the following year, when spores from the perithecia of the fungus are set free and renew their growth on other hosts, the wind probably acting as carrier.

**Ruhlandiella berolinensis, g. et sp. n.‡**—P. Hennings has so named a member of the Rhizinaceæ, a small globular body surrounded by a palisade-like envelope of asci and paraphyses. The fungus is closely akin to *Sphærosoma*, the spores are very similar. It grew on turf-soil in a conservatory at Berlin.

**Disease of the Vine.§**—Herm. Müller-Thurgau gives a detailed account of the fungus causing the disease known as red-brand. The mycelium attacks the leaves of the vine, causing burnt-looking patches. So long as the mycelium is purely parasitic on the living leaf, it inhabits the vessels. It invades the neighbouring cells on the death of the tissue, and externally conidiophores of branched hyphæ with terminal conidia are formed. The fungus was grown in artificial cultures and sclerotia were produced after considerable time, but no further stage was noted.

The writer then examined the leaves killed by the disease, and found, growing on them, a species of *Pseudopeziza*. He cultivated the ascospores and produced a similar mycelium to that grown from the mycelium taken from the leaf; finally he produced conidiophores and conidia in the cultures, which corresponded with those that grew on the diseased leaves. The infection of a healthy vine with the ascospores has not yet been attempted.

The name *Pseudopeziza tracheiphila* was given to the fungus as in the early stages it is confined to the vessels of the host-plant.

\* Hedw. Beiblatt, xlii. (1903) pp. 17-20.

† Forstwiss. Centralbl., xxiv. (1902) pp. 473-9. See also Centralbl. Bakt., x. (1903) pp. 200-1.

‡ Hedw. Beiblatt, xlii. (1903) pp. 22-4 (5 figs.).

§ Centralbl. Bakt., x. (1903) pp. 81-8 and 113-21 (5 pls.).

Müller-Thurgau observed that the disease was most prevalent in light soils where the vines were apt to suffer from want of water. They were consequently feeble and liable to be attacked by the red-brand. He advocates the careful removal or burying of all leaves before the spores of the apothecia are developed. He recommends also an early spraying with Bordeaux mixture.

**Disease of Sorbus Aucuparia.\***—A. von Jaczewski found a species of *Leptosphaeria* causing greyish round spots with a brown margin on the leaves of the mountain ash. He thinks it is probably the ascus form of *Septoria Sorbi* already described. As the ascus form is new he calls it *Leptosphaeria Sorbi*.

**Gooseberry Mildew in Europe.†**—E. S. Salmon detected this American pest in Ireland in 1900, the first recorded appearance in Europe. Since then the disease has appeared in numerous fresh localities in Ireland and in two widely-separated districts in Russia. More recently it has been found that the fungus also attacks red currants. It grows on several species of *Ribes* in the United States. It is a plague much to be dreaded by fruit-growers.

**Notes on Erysiphaceæ.‡**—J. G. Sanders publishes a note on the variation in the form of the appendages of *Podosphaera oxyacanthæ*. On an average, about half the number of perithecia he examined were compound appendages, in varying degrees of development.

**Xylariæ of South America.§**—Karl Starbäck describes the members of this family collected on the first Regnell expedition. He has added a considerable number of new species to the various genera, and has described one new genus *Solenoplea* with one species *microspora*. The stroma is marginate, and is closely packed with cylindrical perithecia. The genus is allied to *Nummularia*.

**Study of Heredity.||**—W. W. Lepeschkin has taken up the study of one-celled organisms such as yeasts, to throw light, if possible, on the question as to whether species arise by gradual selection, or by sudden variation. He selected *Schizosaccharomyces* for experiment, and obtained a seemingly new form of fungus which, had it been formed in nature, would have been placed in *Endomyces* rather than in *Saccharomyces*. He discusses at length the growth of the fungus and the theories as to the transmission of characters in its development.

**Cytology of Yeast.¶**—A. Guilliermond reviews previous work on this subject, specially noting Wager's conclusions that the vacuole in the cell was the nucleus and that the body always associated with it was the nucleolus. The writer finds, as did Wager, the granular bodies in the vacuole, but he finds them also in the cytoplasm of the cell. He demonstrates them first of all in a yeast of a *Dematium* sp., where they are quite separate from the nucleus. Also in *Oidium lactis*, he finds

\* Ann. Myc., i. (1903) pp. 29-30.

† Journ. Roy. Hort. Soc., xxvii. (1902) pp. 596-601 (with fig.).

‡ Journ. of Myc., viii. (1902) p. 170.

§ Bihang K. Svensk. Vet.-Akad. Handl., xxvii. pt. 3, No. 9, 26 pp. (1 pl.).

|| Centralbl. Bakt., x. (1903) pp. 145-51 (2 pls.).

¶ Rev. Gén. de Bot., xv. (1903) pp. 49-66 (9 pls.) and 104-24 (30 figs.).

these same bodies which he has termed metachromatic corpuscles. The yeast of *Oidium* was multi-nucleate. In the true yeasts he describes the same structures; the small nucleus (Wager's nucleolus), consists of colourless nucleoplasm, a nucleolus, and a surrounding membrane. It is connected with the vacuole, he considers, only because the cell is small and the contents necessarily lie close together. When budding takes place, the vacuole passes partly into the new cell and divides, but quite independently of nuclear division. The later takes place as typical amitosis. In some cases the nucleus elongates, penetrates the new cell, and then divides; in other cases it divides without any perceptible stretching, and one of the two resulting nuclei travels into the daughter-cell.

In addition to the vacuole with metachromatic corpuscles, he found in the yeast-cells vacuoles filled with glycogen. These were most prominent during active fermentation, almost filling the whole cell. As fermentation declines, the glycogen tends to disappear, and the corpuscular vacuole takes its place. Wager had already noted this peculiarity and distinguished them as nuclear and glycogen vacuoles. Guilliermond considers that the granulations are of the same nature as the metachromatic corpuscles of bacteria. A careful account of the methods of preparation, staining, &c. is given.

In a further communication, he describes the phenomena accompanying fusion and spore-formation in three species of yeast. He finds in them a true isogamous conjugation which precedes the formation of the ascus and concludes therefore that the ascus is a zygote.

In another paper,\* the same writer gives in detail the process of spore-production in *Saccharomyces Ludwigi*. Hansen had already noted the peculiar germination of this species by means of a promycelium after fusion of two spores. Guilliermond verified Hansen's results, and gives an account of the formation of the germinating tube or promycelium, and of the previous spore-fusion. In some cases, when growing on carrot, the fused body formed an ascus immediately, containing 4 spores. Usually the ascus was formed from part of the promycelium. He also was able to observe the fusion of the nuclei of the two conjugating spores. The writer discusses the systematic position of this yeast and considers that it ought to be separated from *Saccharomyces* and placed under another genus or sub-genus. The paper is well illustrated by a plate and by numerous figures in the text.

**Formation of Yeast-Spores.**†—Chr. Emil Hansen has succeeded in inducing the formation of spores in the yeast-cell without any intervening vegetative development or any previous fusion of cells. He grew the yeast *Johannisberg II.* in a film of water, then in a film of wort. They were again transferred to a solution of calcium sulphate which stopped the process of budding, but not that of spore-formation. After 3–6 days it was found that the spores had become spore-mother-cells, and that spores were formed inside them. Two illustrations accompany the paper.

\* Bull. Soc. Myc. de France, xix. (1903) pp. 19–33 (1 pl.).

† Compte-rendu des travaux du laboratoire de Carlsberg, v. (1902) livr. 2. See also Centralbl. Bakt., x. (1903) p. 125.



In a further paper\* in the same journal, Hansen discusses the conditions necessary or favourable to the vegetative and spore-development of yeasts and of the moulds that take part in alcoholic fermentation. He finds that oxygen is necessary for spore-formation in yeast, though the ordinary yeast-growth can go on in an atmosphere of nitrogen, free from oxygen. Nourishment is not so important as a determining factor: spore-formation as well as budding takes place in rich cultures. Experiments were also carried out on several species of *Mucor*, and the conditions given by which zygospores or sporangia can be produced. There are four illustrations.

**Development of Yeast in Sugar Solution without Fermentation.**‡ Iwanowski publishes a reply to A. Richter, and repeats his work on yeast. He finds that the two most important factors in inducing fermentation are the concentration and the composition of the culture solution. The higher the ratio of nitrogenous substance the weaker the fermentation, which again becomes stronger with a larger amount of sugar. He gives detailed tables of his experiments and the results obtained. In two succeeding numbers of the journal he continues the discussion, repeating his experiments. He gives careful tables of the composition, duration, and temperature of his cultures, and affirms again that yeasts can live on sugar almost without alcoholic fermentation in suitable conditions. That is, in a solution of weak concentration. He also proves that the presence of oxygen exerts considerable influence on the results obtained.

**Industrial Ferments of Eastern Asia.**‡—H. Neville has published an account of the various organisms employed by the Chinese and others in making spirits from rice, &c. A number of forms of *Mucor* used in fermentation are described, as also species of *Aspergillus*, *Monilia*, and *Saccharomyces*. The last chapter of the book deals with the substances employed in fermentation.

**Asterconium Saccardoi.**§—H. and P. Sydow found this new member of the Melanconiaë on leaves of *Litsea glaucescens* from Mexico. Both sides of the leaf bore the cushion-like outgrowths that contained the spores, which are colourless, one-celled, and with conical protuberances that give them a star-like form.

**Septoria.**||—M. C. Potter describes the disease of carnations due to *Septoria Dianthi*. The affected parts are of a light straw colour, the tissues shrink, and the leaf often curls longitudinally. On the diseased areas there are small black pycnidia filled with the long colourless spores of the *Septoria*. The disease was first noticed by the writer in Warwickshire.

An account ¶ of a severe epidemic caused by the same parasite in Liguria and Provence is given by P. Voglino. He finds that the fungus

\* Tom. cit. See also Centralbl. Bakt., tom. cit., pp. 125-30.

† Centralbl. Bakt., x. (1903) pp. 151-4, 180-3, and 209-14.

‡ 'Encyclopédie scientifique des aide-mémoires,' Paris, 1902, 192 pp. See also Centralbl. Bakt., x. (1903) pp. 130-1.

§ Ann. Myc., i. (1903) pp. 35-6.

|| Journ. Roy. Hort. Soc., xxvii. (1903) pp. 428-30 (3 figs. in text).

¶ Stazioni Sperimentali Agrarie, xxxv. (1902) p. 17 (3 figs.). See also Centralbl. Bakt., x. (1903) pp. 108-9.

can live saprophytically on the dead leaves and can resist a long period of drying. He recommends pulling and destroying the diseased leaves.

R. Saritz \* notes the occurrence of *Septoria Spergulariæ* sp. n. on *Spergularia rubra* in the neighbourhood of Dessau.

**Sterigmatocystis pseudonigra.** †—Constantin and Lucet have endeavoured by culture and examination to determine the autonomy of this species. They find that the microscopic characters exactly resemble those of *S. nigra*; but there are slight differences in culture appearance which are constant for the two fungi. The writers are inclined to think that the distinctions merit specific rank.

**Nutrition of Sterigmatocystis niger.** ‡—Henri Coupin has tested the growth of this fungus in Raulin's solution, eliminating one and another of the elements composing it. Raulin had found that sulphate of zinc was advantageous to fungus growth. H. Coupin, with improved methods, concludes that the favourable result was due to the antiseptic nature of zinc, and that in properly sterilised solutions zinc is rather hurtful than otherwise. Iron and silicon are also of no use to the fungus. In a solution deprived of tartaric acid, Raulin failed to get any growth as the culture was so quickly invaded by bacteria; with proper sterilisation, growth of *Sterigmatocystis* can be obtained in a solution at first slightly alkaline. It is slow at first, but the mycelium gradually provides its own acidity, and development then proceeds rapidly.

**St. John's Disease of Peas.** §—This disease is so named because it makes its appearance about the period of St. John's day, towards the end of June. C. van Hall finds that it is a root trouble and caused by the fungus *Fusarium vasinfectum*, of which this is a new variety. The plants turn yellow and die off, the roots having been invaded by the mycelium of the fungus, the development of which is similar to that causing the disease of cotton, watermelon, and cowpea in America. Culture and infection experiments leave no doubt as to the accuracy of the author's diagnosis. In some districts in Holland the culture of peas has had to be given up, owing to this disease.

Some plants of *Sesamum orientale* || from Turkestan were found by A. von Jaczewski to be attacked by a *Fusarium*, the development of which was identical with that of *F. vasinfectum*, and which has occurred on a great variety of plants. Its absolute identity with the disease of cotton cannot be assured until the perithecial stage *Neocosmospora* has been found. The writer gives figures of mycelium and spores.

**Polydesmus exitiosus and Alternaria Brassicæ.** ¶—Pietro Voglino has compared these two fungi by examining both and cultivating both on the same host, namely cauliflower. The only difference noted between

\* Hedw. Beibl., xlii. (1903) p. 32.

† Bull. Soc. Myc., xix. (1903) pp. 33-44.

‡ Comptes Rendus, cxxxvi. (1903) pp. 392-4.

§ Ber. Deutsch. Bot. Ges., xxi. (1903) pp. 2-5 (1 pl.).

|| Ann. Myc., i. (1903) pp. 31-2.

¶ Malpighia, xvi. (1902) pp. 333-40 (1 pl.).

them is the length of hyphæ that intervenes between the catenulate spores, and the muriform character of the spores in *Alternaria* as compared with the transverse divisions in the spores of *Polydesmus*. Voglino proves that the distinction breaks down and that the two forms are really one and the same, and ought to be united under the earlier name *Alternaria Brassicæ*. He demonstrated also the parasitic nature of the fungus. It causes a troublesome disease on several forms of *Brassica*.

### Schizophyta.

#### Schizophyceæ.

**Floating Properties of certain Phycchromaceæ.\***—H. Molisch has examined certain species of this group of algæ, notably *Aphanizomenon flos-aquæ*, and comes to the conclusion that the view held by authors as to the nature of the red bodies in many of the cells is not correct. It has been considered by Strodtmann, Klebahn, and others that these bodies are gas-vacuoles, since when they are present the algæ float on the surface of the water, and when they are artificially removed the same algæ sink to the bottom. The present author gives reasons, founded on his own investigations, to show that these floats (*Schwebekörper*) are not gas-vacuoles, but seem rather to consist of a more or less viscous substance inclosed in a delicate membrane. If this view be correct, it is easy to explain the result of certain experiments detailed here. The author is inclined to believe that the so-called sulphur-grains or gas-vacuoles of *Thiothrix tenuis* are bodies of the same more or less viscous substance.

#### Schizomycetes.

**Physiology of Spore-formation in Bacteria.†**—Matzuschita has made observations on the effect of external conditions upon endogenous spore-formation, especially in anaerobes. The general result obtained was that to all changes of external conditions, such as concentration of medium, temperature and pressure, addition of noxious substances, spore-formation was more sensitive than growth.

**Bacterial Origin of Vegetable Gums.‡**—R. Grieg Smith, of Sydney, has been led by his previous work on the gums and slimes produced by bacteria, to investigate other gums which are supposed to be the secretions of higher plants. Gum acacia was investigated. From *Acacia binervata* a bacterium was separated which in artificial media produced a slime which yielded a gum giving all the reactions of gum acacia. There can thus be no doubt that this gum is of bacterial origin. The bacterium, to which the name *B. Acaciæ* was given, is rod-shaped, measures 0.5–0.6 by 0.5–2  $\mu$ , is not stained by Gram's method, and has one to many peritrichous flagella. It is aerobic and produces no spores; it grows at 37° C., but most slime is produced at 15°–22° C. From *Acacia penninervis* there were isolated two bacteria, one, *B. Acaciæ*,

\* Bot. Zeit., 1903, pp. 47–58 (4 figs. in text).

† Arch. f. Hygiene, xliii. p. 267. See also Centralbl. Bakt., x. (1903) pp. 123–5.

‡ Proc. Linn. Soc. N.S. Wales, 1902, pt. 3. See also Centralbl. Bakt., x. (1903) pp. 61–3.

the other, a stouter similarly flagellated form to which is given the *B. metarabium*. This bacterium is the producer of the insoluble (metarabin) gums as the other is of the soluble (arabin) gums.

→ **Colourless Bacterium obtaining Carbon from the Air.\***—Beijerinck and van Delden, in a very important paper, describe a new bacillus *B. chiyocarbophilus*, which is able to grow in solutions containing only mineral salts. The carbon necessary for its growth is obtained from the air, not from the carbon dioxide, but from a complicated carbon-compound (or compounds) present in the air in small quantities, the exact nature of which is not clearly understood. The existence of a complex carbon-compound in the air was first suggested by Karsten in 1862; of late years this body has been investigated by Henriët, who believes that it also contains nitrogen. The bacillus is widely distributed in the soil, and can easily be obtained by infecting with garden-earth ordinary nutritive salt-solutions (such as are used by botanists for water-cultures), but made alkaline with  $K_2HPO_4$  instead of acid with  $KH_2PO_4$ . The bacteria soon form a thin, snow-white, dry layer upon the surface of the fluid. The nitrogen can be supplied either in the form of potassium nitrite, or an inorganic ammonium salt. No use can be made either of the free carbon dioxide of the air or of that contained in carbonates in solution. The presence of organic carbon-compounds is inimical to its growth, but, like the nitrifying bacteria it can be grown under suitable conditions on agar and silicic acid (water-glass).

**Bacterial Flora of the Nose.†**—Hasslauer has investigated the bacterial flora of the mucous membrane of the nose of man in health and disease. Eighty-four persons of various occupations was examined, and in nearly all cases a large number of bacteria was met with both in the healthy and diseased cases, but in no case was the tubercle bacillus found.

**Cultivation of Anaerobic Bacteria.‡**—A. Weichselbaum gives a short introduction on the gaps in our knowledge of anaerobes, and his assistants, Dr. Anton Gohn and Dr. Milan Sachs give a detailed account of the technique employed in studying these forms.

**Biology of Anaerobic Bacteria.§**—Karl Koninski has made a series of observations on the cultural characters in parallel series of gangrene and œdema bacillus. In some of the experiments these two anaerobes after being infected on the surface of gelatin, where they naturally remained sterile, were made to grow by a later infection with the aerobic *Micrococcus candidans*.

**Effect of Oil on Bacteria.||**—Dr. Kurpjuweit has investigated the capacity of bacteria to live in oil, especially in relation to the use of oil for lubricating catheters. Ordinary olive oil was investigated and found to contain bacteria but not pathogenic forms. The effect of olive oil upon various pathogenic bacteria was also investigated and it was found that they remained living for some time, up to 10 days, in the oil;

\* Centralbl. Bakt., x. (1903) pp. 33-47.

† Op. cit., xxxiii. (1903) pp. 47-51.

‡ Op. cit., xxxii. (1902) pp. 401-13.

§ Tom. cit., pp. 569-73.

|| Op. cit. xxxiii. pp. 157-60.

typhus bacilli and *Bacterium coli* remained living for the longest time. The conclusion is that the oil should be sterilised and that the catheter should never be placed in oil but some of the latter removed for the purpose; the catheter should then be sterilised from time to time in the water-bath.

**Bacteria in Pus from a Gas-containing Abscess.\***—Rodella has investigated the pus from such an abscess and finds besides a *Streptococcus* and an organism belonging to the coli group, two anaerobic rod-like forms which are further described, one having the power of gas-formation.

**Pigment Bacteria of Water.†**—D. Fernandez has investigated the bacteria of the water-supply of the town of Buenos Ayres especially in relation to the pigment-bacteria. The water is derived from the Rio de la Plata and is a dark yellow colour owing to the admixture of loam-constituents. The bacterial contents of the water varies between 10–50,000 per c.cm. before filtration through sand, which reduces the number to 200–2000 per c.cm. The characters of nearly 100 different forms are described, most of them being pigment-bacteria, but names are given to only very few.

**Bacterium Pathogenic for House-Rats.‡**—Toyama has described a pathogenic bacterium fatal to the ordinary house-rat in Tokio. The organism was isolated, and studied both in artificial cultures and by inoculation. For mice and house-rats it was strongly virulent, but was without effect on guinea-pigs and ordinary rats. It showed a number of resemblances to Loeffler's *B. typhi murium* but did not agree in all particulars; the question as to its being a distinct species was left undecided.

**Passage of Bacteria through Filters.§**—Erwin von Esmarch has made some important investigations on the question of the passage of bacteria through filters. It has been known for some time that the organisms which produce some diseases are so small as to be scarcely visible if at all by the best Microscopes. The virus of peripneumonia of cattle was found by Nocard and Roux to appear under the highest powers merely as tiny refractive granules which passed easily through the Berkefeld and Chamberland filters. The foot-and-mouth disease of Loeffler and Frosch, and the disease of tobacco-leaves described by Beijerinck, and several other animal affections seem to be of this class. Prof. Esmarch has set himself to discover whether similarly minute forms are to be found amongst the saprophytic bacteria. Various pond- and ditch-waters, and a large number of infusions of decaying matter were investigated by filtration through the Berkefeld filter. To the filtrate were then added very various nutritive solutions to encourage the growth of any bacteria that might be present. The results were, in all cases but one, negative. They might, however, be explained not by the absence of the minute organisms which were sought for but by the want of suitable conditions of growth.

\* Centralbl. Bakt., xxxiii. (1903) pp. 135–42 (1 pl.).

† Op. cit., xxxii. (1902–3) pp. 34–40, 97–135.

‡ Op. cit., xxxiii. (1903) pp. 273–81.

§ Op. cit., xxxii. (1902) pp. 561–9 (1 pl.).

In the one case mentioned a tiny comma-like spirillum was found which easily passed the filter even when only 300–400 c.cm. had been drawn through. This minute organism is about the size of the influenza-bacillus, but considerably smaller than the bacillus of mouse-septicæmia. In Canada balsam it measured 1–3  $\mu$  long and 0·1–0·3  $\mu$  broad; it was a mobile form with a flagellum at one end. To it the name of *Spirillum parvum* was given.

Experiments were also made on the method by which the bacteria got through the substance of the filter, and micro-photographs are given of thin slices of the filter-substance showing the bacteria *in situ*.

**New Red Pigment-forming Bacillus.\***—Petrow describes a bacillus, found by spontaneous infection of gelatin from the air, which has many analogies with *Bac. kiliensis*, and is accordingly named *Bac. subkiliensis*. The rods are 1–1·2  $\mu$  long and 0·8  $\mu$  thick and have 5–9 flagella distributed generally over the body. Spore-formation was not observed. The red pigment, which is early produced, is insoluble in water, but soluble in alcohol, ether, chloroform, &c.

**Question of Species in the Bacteria of Leguminous Tubercles.†**—H. Buhlert has continued his observations on the question of species in this difficult group of bacteria. The later observations agree with the former in supporting the view of the existence of species among these forms.

**Epidemic of Guinea-pigs caused by a Variety of Bacterium coli.‡** Karl Kovářík describes a new epidemic disease of guinea-pigs observed in Budapest, caused by a bacillus of the coli-group, but not, however, identical with any of the described varieties of *Bact. coli commune*.

**Influenza-like Bacillus from a Rat.§**—Alfred Wolff also describes a bacillus, resembling very much the influenza-bacillus, which was isolated from a purulent slimy secretion observed in the bronchi of a wild rat which had died from the effects of injection of cholera-toxin.

**Influenza-like Bacillus from a Dog.||**—E. Friedberger describes an influenza-like and hæmoglobinophilous bacterium obtained from the diseased preputial secretion of a dog. The name *Bacillus hæmoglobophilus canis* is given to it.

**Micro-organism infecting small Animals in the Laboratory.¶**—Dr. Schwer describes a bacterium (*Bact. cavisepticum*) which for the last three years has caused an epidemic amongst guinea-pigs, rabbits, and white rats kept for laboratory purposes. In structure and staining reaction the organism resembles *Bacillus cholera-gallinarum*, but the difference in growth is so great that there is no doubt that it is a distinct form.

**Leprous Affection of the Skin and Lymph-glands of Sewer Rats.\*\***—Stefansky has observed in Odessa a new disease of the sewer-

\* Arb. aus d. Bakt. Inst. der Techn. Hochschule, Karlsruhe, ii. (1902) p. 273 (1 pl.). See also Centralbl. Bakt., ix. (1902) pp. 931–2.

† Centralbl. Bakt., ix. (1902) pp. 892–5.

‡ Op. cit., xxxiii. (1903) pp. 143–9.

§ Tom. cit., pp. 401–6 (1 pl.).

¶ Tom. cit., pp. 407–11 (1 pl.).

\*\* Tom. cit., pp. 41–7.

\*\* Tom. cit., pp. 481–7 (1 pl.).

rats (*Mus decumans*), producing changes in the skin and lymph-glands like those of leprosy, and having in its histological characters many resemblances to that disease.

**New Pathogenic Microbe of the Diphtheria Bacillus Group.\***—E. Klein describes a new pathogenic bacterium, *Bact. muris*, which he isolated from the hepaticised lung of the white rat. It is pathogenic for rats and guinea-pigs and in its staining capacity, morphology, and cultural reactions is very nearly related to the Klebs-Loeffler bacillus.

**Differentiation of the Diphtheria and Pseudo-Diphtheria Bacillus.†**—J. Bronstein and G. W. Grünblatt show how Mankowski's reagent, which was invented for distinguishing the typhus bacillus from the coli bacillus, can also be used for differentiating the diphtheria and pseudo-diphtheria bacilli. A few drops of this reagent are added to bouillon cultures of these two forms, when that of *Bac. Loeffleri* becomes red (rubinrot) and that of the pseudo-diphtheria bacilli, green.

**Rapid Diagnosis of Typhus Bacilli.‡**—Georg Jochmann has made experiments with the medium recommended by Weil for the rapid diagnosis of typhus bacilli and confirms Weil's statement that these bacilli when grown on his medium at 36°–37.5° C. show colonies of characteristic form after only 12 hours. Jochmann finds that though such colonies are usually of typhus bacilli, yet sometimes bacilli of the coli-class form similarly shaped colonies. Reliance must therefore not be placed on the appearance alone of the colonies, but the differential diagnostic method must be used for confirmation.

**Characters of Meningococcus intracellularis.§**—H. Jaeger, in a somewhat polemical article, reiterates his views on the cause of epidemic cerebro-spinal meningitis, and casts doubt on the views put forward by Albrecht and Ghon in relation to *Diplococcus Weichselbaum*.

**Pneumococcus which liquefies Gelatin.**—A. Kindborg || describes from a case of croupous pneumonia a pneumococcus, which has the distinguishing peculiarity of liquefying gelatin. It grows easily on all the usual media, and is pathogenic for white mice but not for rabbits. Only two of the numerous forms described under pneumococcus appear to have this power of liquefying gelatin, namely that described by Kruse and Pansini, and that described by Eyre and Washbourn.

**New Bacterium in freshly-drawn Milk.¶**—F. C. Harrison and M. Cumming describe a new species, *Bact. halofaciens*, which is of frequent occurrence in fore and after milk. It occurs singly, is motile, and forms no spores; has an optimum temperature 37°; is aerobic and facultative anaerobic; is slow to liquefy gelatin; and white, dirty brown, and finally yellow in colour. It stains evenly with anilin dyes.

It approaches *Bact. annulatum* Wright, but differs in several details. Its name recalls the characteristic halo found in gelatin cultures. The flavour of butter made from cream ripened with a culture of the new bacterium was not strong but quite disagreeable.

\* Centralbl. Bakt., xxxiii. (1903) pp. 488–9.

† Op. cit., xxxii. pp. 425–8.

§ Op. cit., xxxii. (1902) pp. 23–4.

¶ Journ. Appl. Micr., v. (1902) p. 2033.

‡ Tom. cit., pp. 460–6.

|| Tom. cit., pp. 573–6.

**Paratyphoid Fever.\***—According to De Feyfer and Kayser, Schottmüller obtained cultivations of typical typhoid bacilli in 80 per cent. of cases (numbering 118) diagnosed as typhoid fever; in seven cases an organism of aberrant type was present. Kurth found a similar organism, which is now known as the paratyphoid bacillus, of which there are two types, A and B. In cultural characteristics both are intermediate between the typhoid bacillus and the *Bacillus coli communis*. They ferment sugar but do not coagulate milk, and unlike the typhoid bacillus cause fluorescence in neutral-red agar. They do not produce indol in broth. A grows less luxuriantly and more slowly on all media than B. Colonies of A are thin, glistening, and almost transparent; those of B are thicker and whitish. On potato the growth of A is invisible, while B forms a thick grey-brown pellicle, like the colon bacillus. A does not change milk, B in the course of weeks renders it limpid. Finally the agglutination reaction is specific for both A and B. The two types therefore differ from each other as much as they do from the typhoid and colon bacillus.

**Etiology of Sleeping Sickness.†**—Aldo Castellani, a member of the Commission sent to Uganda to investigate this disease, was unable to find any of the germs described by previous workers, but found a new variety of *Streptococcus* which he considers to be the cause of sleeping sickness. He has grown the micro-organism in nine out of eleven necropsies. The microscopic appearance is very variable, depending upon the media of cultivation, on the times of growth, &c., all transitions from long chains to typical diplococci being seen. The form and size of individuals are also variable. Well-defined mucoid capsules are frequently seen about the chains and diplococci-forms, and in hang-drop preparations the short chains and diplococci-forms show a well-marked Brownian movement; involution forms occur in old cultures. It is easily stained with ordinary anilin-dye solutions. Details of cultivation in various media are given. Experiments on agglutination are not complete, but results are so far satisfactory. The new variety is distinguished from *Streptococcus lanceolatus* by the cultivation in gelatin as *S. lanceolatus* does not grow, or grows only very badly on that medium. From *S. pyogenes* it is differentiated by its much more vigorous growth on all media and especially on agar, by the tendency of its colonies to coalesce, and by the non-coagulation of milk. The author thinks it a distinct variety between *S. pyogenes* and *S. lanceolatus*.

#### Mycetozoa.

**Lepidoderma.‡**—A. F. Morgan describes a species he has found which corresponds with *Didymium Geaster*. He describes it and classifies it under *Lepidoderma*.

\* Münch. Med. Woch., 1902, pp. 1692 and 1752. See also Med. Rev., 1903, pp. 17-20.

† Brit. Med. Journ., 1903, i. pp. 617-8.

‡ Journ. Myc., lxx. (1903) pp. 3-4.



## MICROSCOPY.

## A. Instruments, Accessories, &amp;c.\*

## (1) Stands.

Beck's Portable "Star" Microscope.†—This instrument, called Stand No. 43 by the makers, is shown in fig. 54.

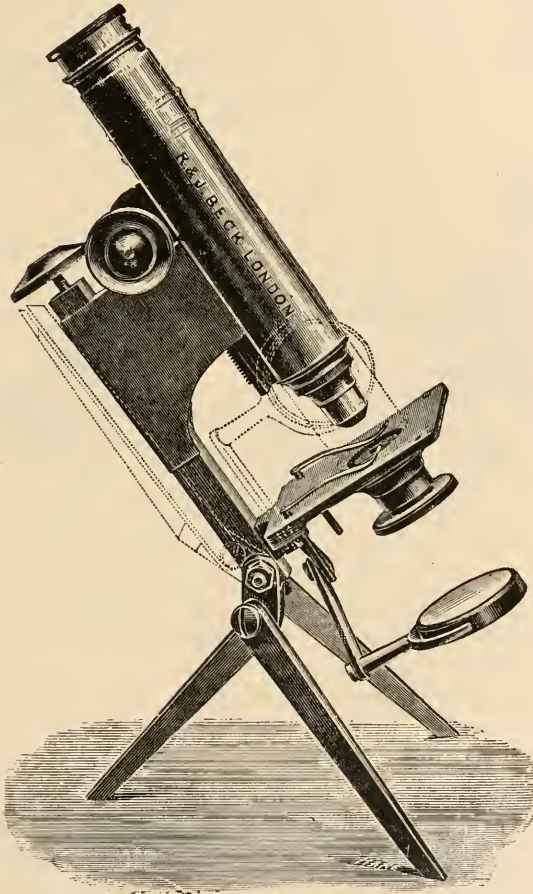

FIG. 54.

\* This subdivision contains (1) Stands; (2) Eye-pieces and Objectives; (3) Illuminating and other Apparatus; (4) Photomicrography; (5) Microscopical Optics and Manipulation; (6) Miscellaneous.

† Messrs. R. and J. Beck's Catalogue, London, p. 18.

It has rack-and-pinion coarse adjustment, and the fine adjustment is by micrometer-screw. The base is a folding tripod with joint for inclination. It is furnished with draw-tube, double mirror, and iris diaphragm. The leather or walnut case, in which it is packed, measures only about  $6\frac{1}{2}$  by  $4\frac{1}{4}$  by  $3\frac{1}{4}$  in.

**Beck's Process Microscope.\***—The Microscope illustrated in fig. 55 is specially designed for the examination of "surfaces" in any branch of photo-mechanical work. It is very useful in examining the form of the dots in half-tone work and for watching the process of etching. It may also be used for ascertaining the grain of a collotype or for examining the three-colour work as it comes off the machine. The instrument has a rack-and-pinion movement for focussing with draw-tube. The illumination is provided by a jointed condenser, which can be made to

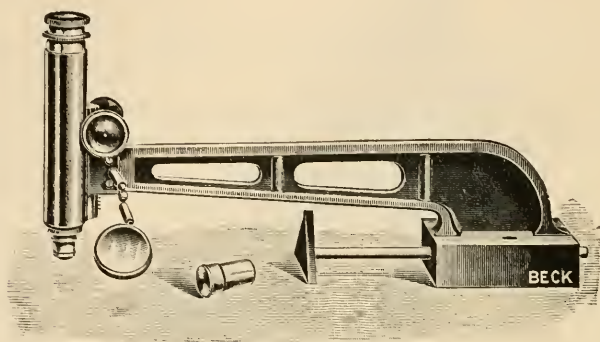

FIG. 55.

move in any direction. The Microscope, with its long arm and heavy base, can be used where desired; or it may be screwed to the bench and the plates passed under it.

**Beck's Pathological Microscope.†**—This is called Stand No. 17 by the makers, and is shown in fig. 56. The build is that of the tripod base and pillar model, and is as rigid and well balanced in the horizontal as in the vertical position. The coarse adjustment is by rack-and-pinion. The patent fine adjustment is by means of a lever actuated by double thread screws, which give the two speeds of  $\frac{1}{80}$  in. and  $\frac{1}{300}$  in. for one complete revolution of the milled head. The fine adjustment is so placed that it can be used without raising the wrist from the table. The mechanical stage has a 2-in. motion in the lateral direction and a 1-in. in the vertical. It is divided and engraved in  $\frac{1}{30}$  in. for purposes of "finding." There is a spiral rack-and-pinion focussing and screw centring substage and a double mirror.

\* Messrs. R. and J. Beck's Catalogue, London, p. 48.

† Tom. cit., p. 38.

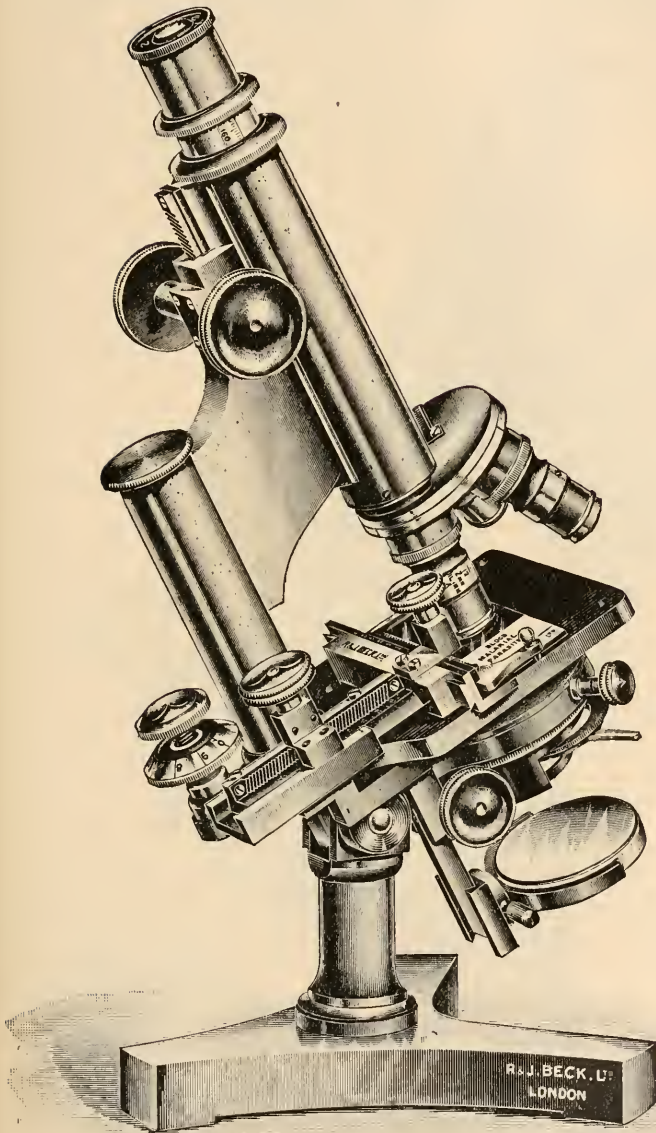

FIG. 56.

Beck's Metallurgical Microscopes.\*—The great desideratum in a metallurgical Microscope is a sufficient distance of stage from body to

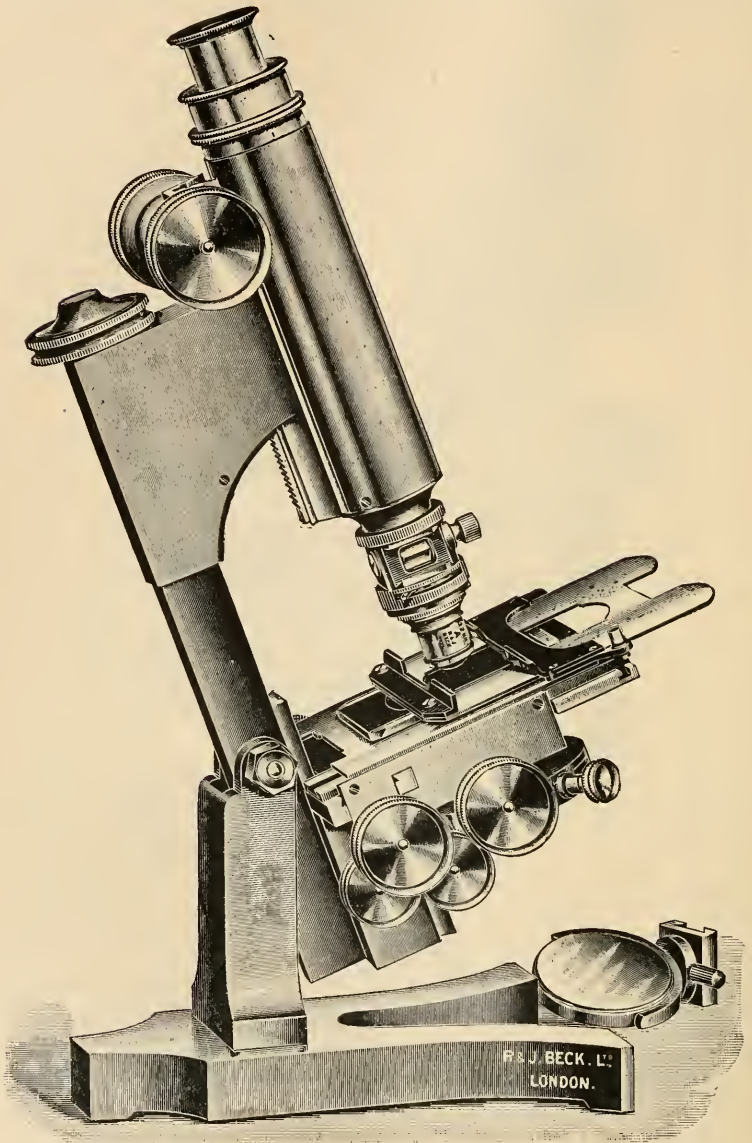

FIG. 57.

\* Messrs. R. and J. Beck's Catalogue, London, p. 46.

permit the use of the observing prism and vertical illuminator at the same time. This is especially provided for in Stand No. 1154 (fig. 57), which has coarse and fine adjustments, inclination joint, and stage with mechanical motion in both directions. Rack-and-pinion adjustments are provided for raising and lowering the stage. The substage has rack-and-pinion focussing and centring adjustments. The same firm adapt their "Imperial" Microscopes for metallurgy by providing an adjustment for racking down the whole stage a distance of 2 in. †

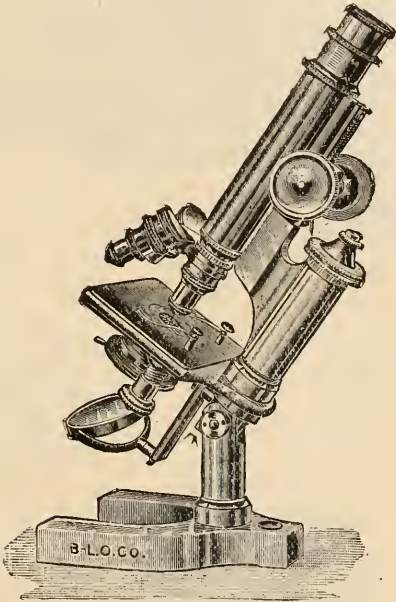

FIG. 58.

**Bausch and Lomb's Continental Microscope, BB Model.**—This instrument, which was exhibited and described by Mr. Rousselet at the March meeting (see p. 244), is shown in fig. 58.

### (3) Illuminating and other Apparatus.

**Koristka's Large Reflecting Mirror.\***—This adjunct, which is shown in fig. 59, is intended to be used as a heliostat. It is then fixed outside the shutter of a dark room and the plane of the mirror so turned as to reflect the light through the tubular mount into the room. The screw-heads allow the slope of the plane to be corrected, from time to

\* F. Koristka's Catalogue, Milan, fig. 65, p. 77. This mirror was originally invented by John Cuff, of Fleet Street, in 1743.

time, as required; they are operated from within the room. The size of the mirror is 11 by 33 cm.

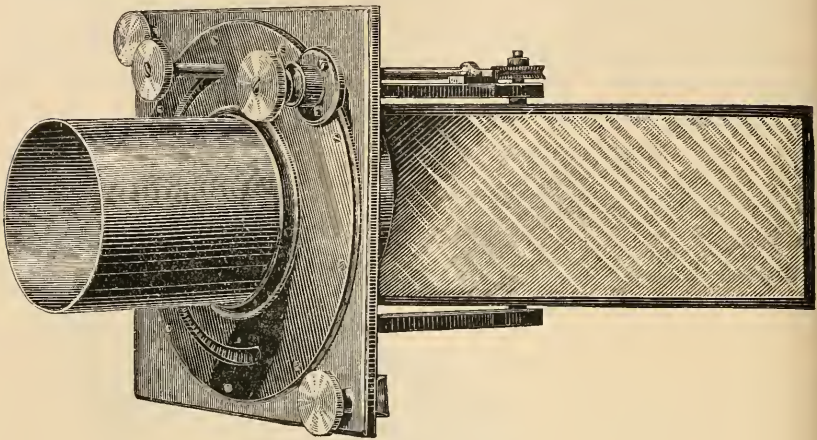

FIG. 59.

**New Electrical Microscope Lamp.\***—H. Poll's apparatus (fig. 60) consists of a small electric incandescent lamp set in the interior of a parabolic hollow mirror. It is of 3 to 7 volts and 4 to 5 candle-power, and is of about the same size as the lamps used for cystoscopic purposes.

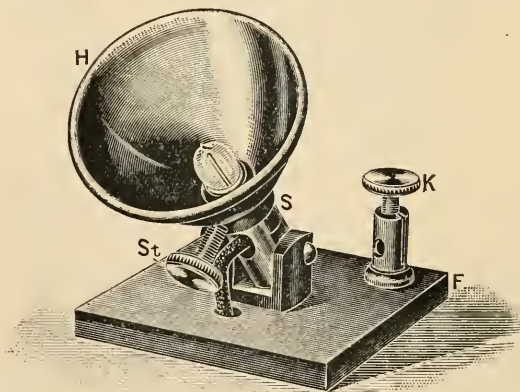

FIG. 60.

It works on the upper end of a pillar S, connected with the foot-plate F by means of a hinge. The foot-plate has two binding screws for bring-

\* Zeitschr. f. wiss. Mikr., xviii. (1902) pp. 413-7 (1 fig.).

ing the instrument into circuit with an electric current obtained from a dry cell or other convenient source. The hollow mirror can be pushed up and down the pillar and clamped by a screw *S*. When the lamp-filament is brought into the focus of the mirror an intensely bright stream of parallel rays is directed outwards. The lamp can be set immediately under the condenser; or the Microscope mirror, if irremovable, can be set at a proper angle for receiving the light horizontally and reflecting it vertically upwards. A coloured disc can be set in the condenser if desired. Simple means are provided for regulating to a nicety the light-intensity. A bibliography on electric lamps is appended to the original article.\*

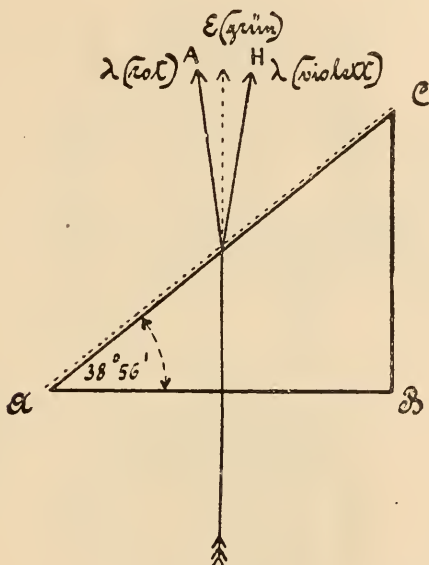

FIG. 61.

**Engelmann's Microspectral Objective with Detachable Thorp's Grating and Detachable Polariser.**†—The invention of the Thorp transparent grating has put a new agency at the disposal of spectroscope makers. The rulings are about 14,560 to an inch, and the intervals are  $1.7 \mu$ . In consequence of this the perpendicularly incident principal rays in the first diffraction spectrum are deviated about  $20^\circ$  for central yellow. The application of such a transparent plane grating in the microspectral objective would have required a corresponding inclination

\* As the rays from the electric lamp are divergent, and those from the parabolic mirror parallel, they cannot both be brought to a focus on the object, at the same time, by the substage condenser.—[ED.]

† S.B. k. preuss. Akad. Wiss. zu Berlin, xxxi. (1902) pp. 711-9 (7 figs.).

of the collimator tube to the projection tube. This inconvenience is avoided by affixing the collodion grating to one of the faces of a glass prism. The glass used is boro-silicate-crown, O 144 of Schott's catalogue, with a refractive angle of  $38^{\circ} 56'$ . The rays proceeding from the collimator tube fall perpendicularly on the base  $AB$  of the right-angled prism  $ABC$ , fig. 61, and when refracted through the hypotenuse  $AC$  are simultaneously dispersed by the grating which is affixed to  $AC$ . [The angle  $BAC$  is  $38^{\circ} 56'$ .] The red end of the first diffraction

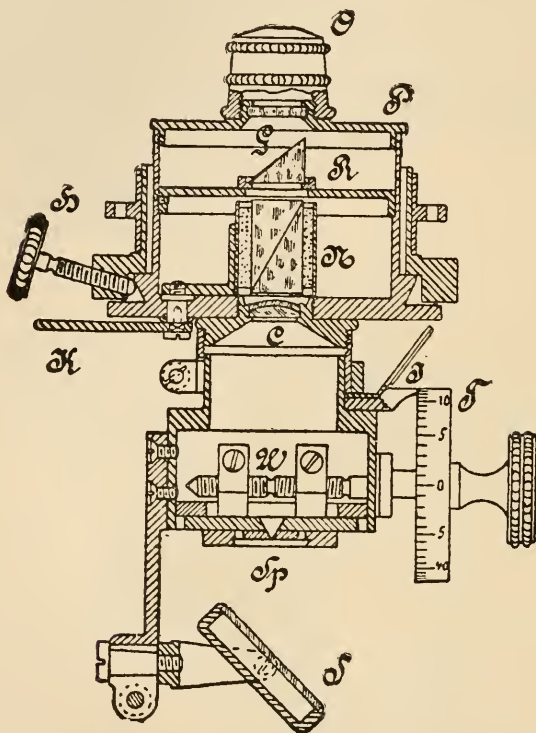

FIG. 62.

spectrum is towards the angle  $A$ , and the violet end towards  $C$ . A ray of medium wave-length (of perhaps  $0.56 \mu$ ) passes through undeviated. Fig. 62 gives in approximately natural size a sectional view of the apparatus.  $Sp$  is the entrance slit whose width is regulated by a spindle provided with a left and a right-handed screw, and the graduations on the drum  $J$  give the width of the slit in hundredths of a millimeter.  $C$  is an achromatic collimator objective of 32 mm. focus and 6 mm. free aperture. Above this is a polariser  $N$  of Ahrens' construction, detachable by a lever  $K$ , thus allowing the use of the instrument as a spectro-



polariser. R is the prism with its film grating, and G a plane-parallel glass plate for protecting the prism chamber. By means of a lever the

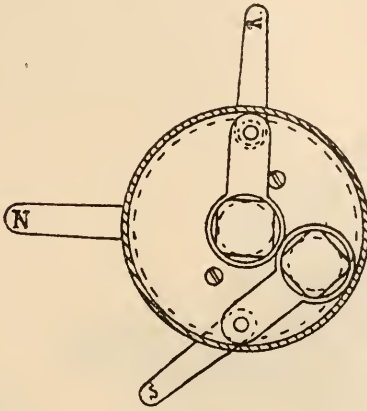

FIG. 63.

prism grating may be moved aside and a film-grating substituted for it. The whole is applied under the stage like a substage condenser.

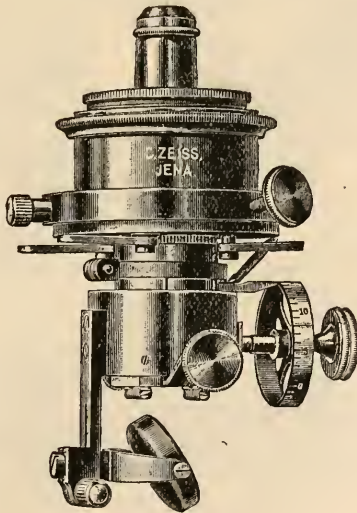

FIG. 64.

Fig. 63 shows the arrangement of levers for detaching the nicol N, the film-grating S, and the prism-grating R.

Fig. 64 shows the actual instrument full size ; fig. 65, fitted to Zeiss' stand 1°.

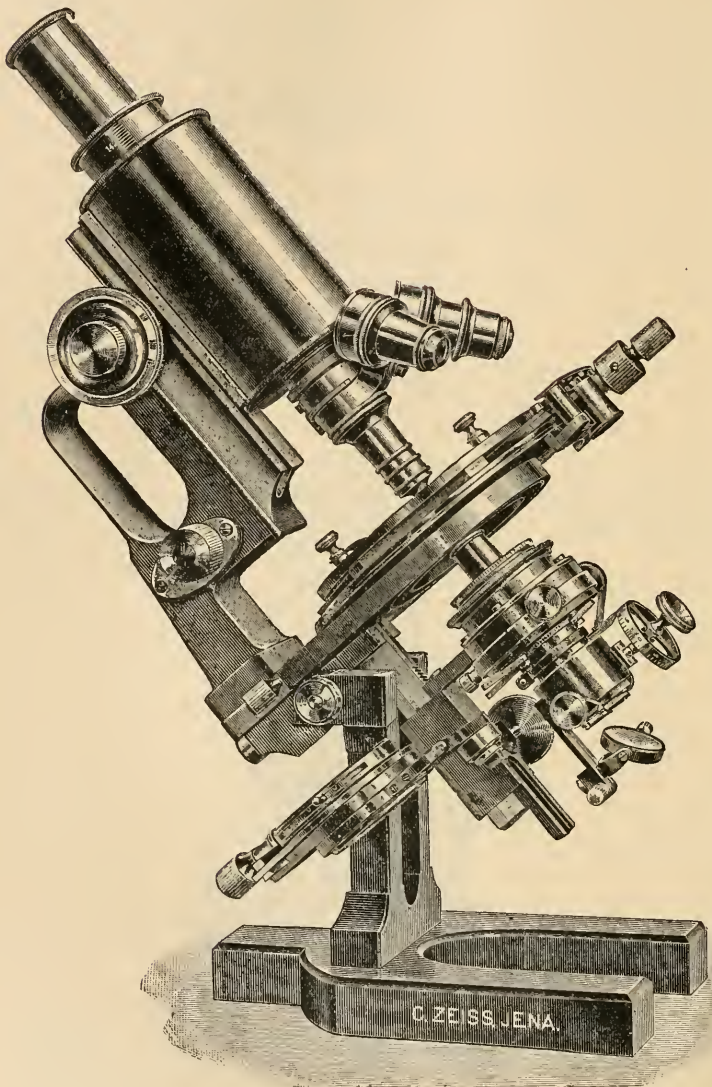

FIG. 65.

## (4) Photomicrography.

**Koristka's Simplified Vertical Camera.\***—This design (fig. 66) is due to Professor Ruffini of Siena, and its nature will be easily understood from the figure. A handle at the top, connected with an endless screw, raises the frame with the focussing screen to a suitable distance. The other end of the bellows is drawn over the ocular and clamped by a screw. The framework can also be used for horizontal photomicrography.

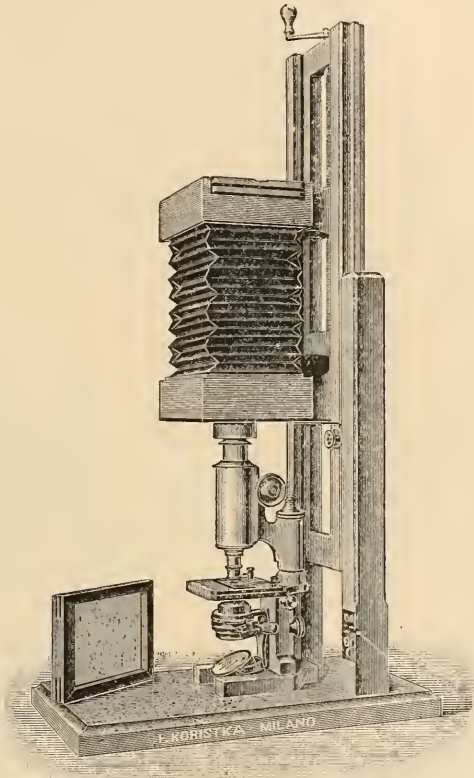

FIG. 66.

**Apparatus for Photographing with Light incident from above and below.†**—F. W. Müller has contrived some changes in the well-known Zeiss apparatus, in order to be able to photograph the upper and under sides of a solid or transparent object. The general arrangements are shown in figs. 69 and 70, the former being for upper side and the latter for under side photography. On the rectangular table which

\* F. Koristka's Catalogue, Milan, fig. 64, p. 76.

† Zeitschr. f. wiss. Mikr., xix. (1902) pp. 44-56 (7 figs.).

carries the optical bench is placed the stand, with the object-stage accurately adjusted in a horizontal position. The object can now be

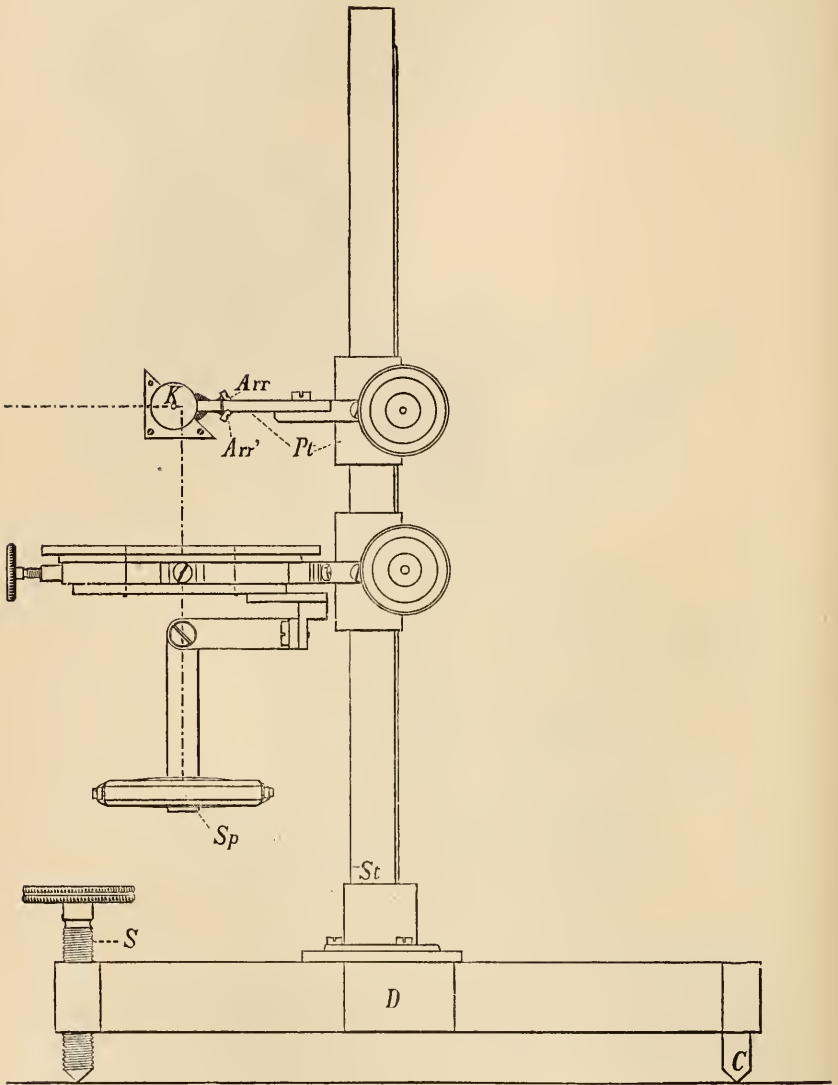

FIG. 67.

illuminated from all sides. A right-angled prism, whose reflecting planes are at exactly  $45^\circ$ , is placed, as required, over or under the object.

The bellows and their stand, which are independent of the preceding, are pushed up to the prism, thus giving a coarse adjustment. On this movable bellows the author has set the objective-tube; this is regulated by rack-and-pinion and thus a fine adjustment obtained.

The stand (fig. 67) possesses a heavy tripod base, the rear foot C of which is rigid, the two front ones S being levelling screws. The pillar is a triangular guide-bar *St* bearing an obliquely-toothed rack on its rear side and centimetre graduations on one of the front sides. At the upper end the bar is simply truncated. The object-stage and prism-holder are easily lifted off the bar over its upper end, both being secured to sleeves worked up and down by pinions engaging with the rackwork. The stage is rotary and can be clamped by screws; it is made of blackened brass and must be pierced by a large aperture to allow of the maximum amount of light being con-

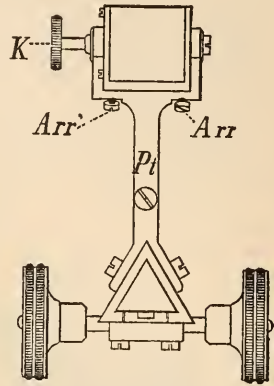

FIG. 68.

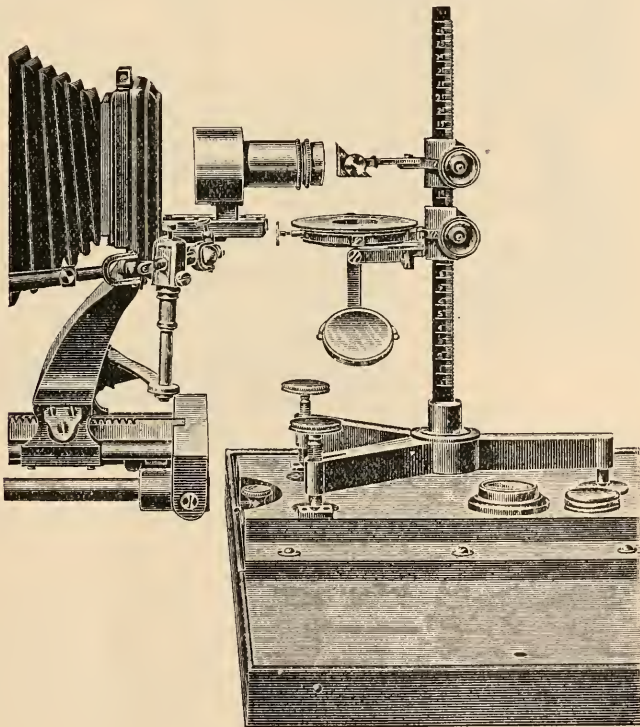

FIG. 69.

centrated from below. A stage of mirror glass with a broad rim cemented on shell-wise can be advantageously used. The illuminating mirror *Sp* can be used on the stage or below it. The prism-carrier *Pt* can be clamped on the guide-bar and must be set in the optic axis: it terminates in a fork, at whose ends are the bearings for the rotation axis of the prism. The size of the prism depends on that of the front lens of the largest objective used. The hypotenuse plane is silvered to improve the reflection. The prism is set in a metal mounting, and its rotation about its horizontal axis is controlled by the milled head *K* (fig. 68)

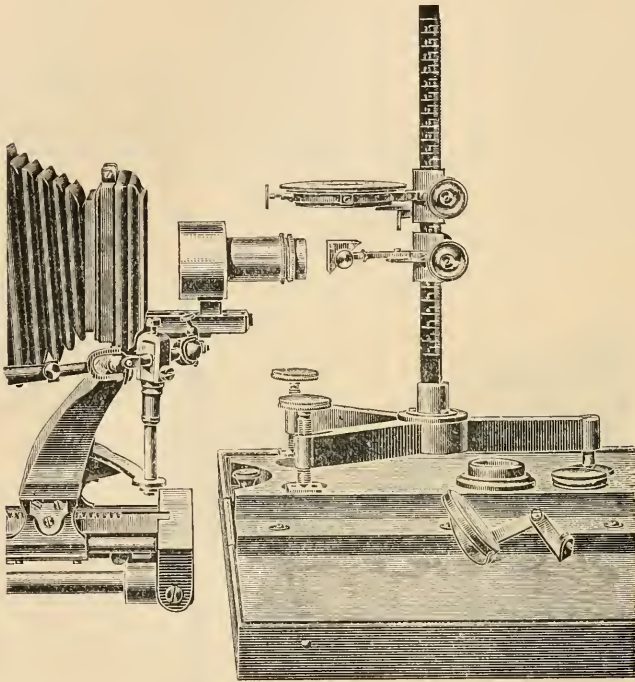

FIG. 70.

and limited by the two stop-screws *Arr*. When the prism has been accurately set, as in fig. 69, with the reflecting plane at  $45^\circ$  to the horizon, by aid of one of the stop-screws, rotation to the other stop turns it through  $90^\circ$  and puts it in the position of fig. 70. The tripod stand is so placed that its feet rest in three prepared spots and is adjusted by means of the two levelling screws. The magnification is estimated in the usual way by means of a magnified glass scale. When the upper surface has been photographed, the stage-holder and prism-holder are unclamped, lifted off, and replaced in reversed order: the prism is rotated through  $90^\circ$  and the under side photographed. For the

luminant, the author uses a nickelled iron reflector with incandescent burner and condenser lenses, whose light he uses direct for downward photography, but employs a hollow mirror for upward work. In order to avoid the inconvenience which may arise from halation, the author puts his plates into the dark slide with their glass side towards the objective.

(5). Microscopical Optics and Manipulation. †

**Engelmann's Microspectralphotometer with Grating Spectrum.\***—H. Siedentopf describes how the Thorp collodion grating has been adapted by Messrs. Zeiss to Engelmann's instrument.

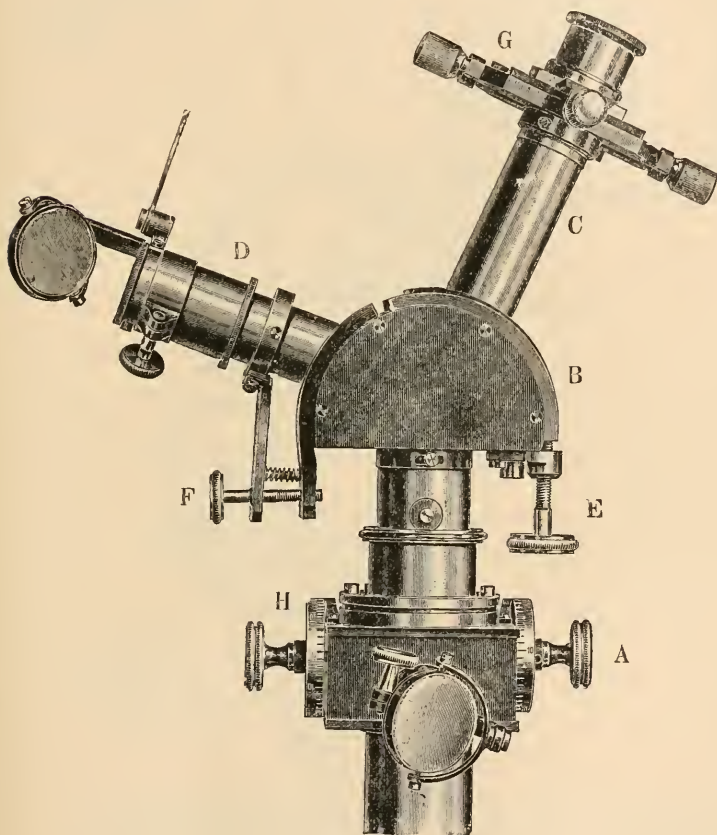

FIG. 71.

Fig. 71 shows the photometer two-thirds of its natural size. On the frame containing the slit the upper part is secured by the clamp-

\* S.B. k. preuss. Akad. Wiss. zu Berlin, xxxi. ii. iii. (1902) pp. 706-10 (3 figs.).

screw H. This upper part consists of a flat semicylindrical box B, and is accurately adjusted to the observation telescope C and scale-tube D. The box contains the Thorp transparent grating. The telescope can by

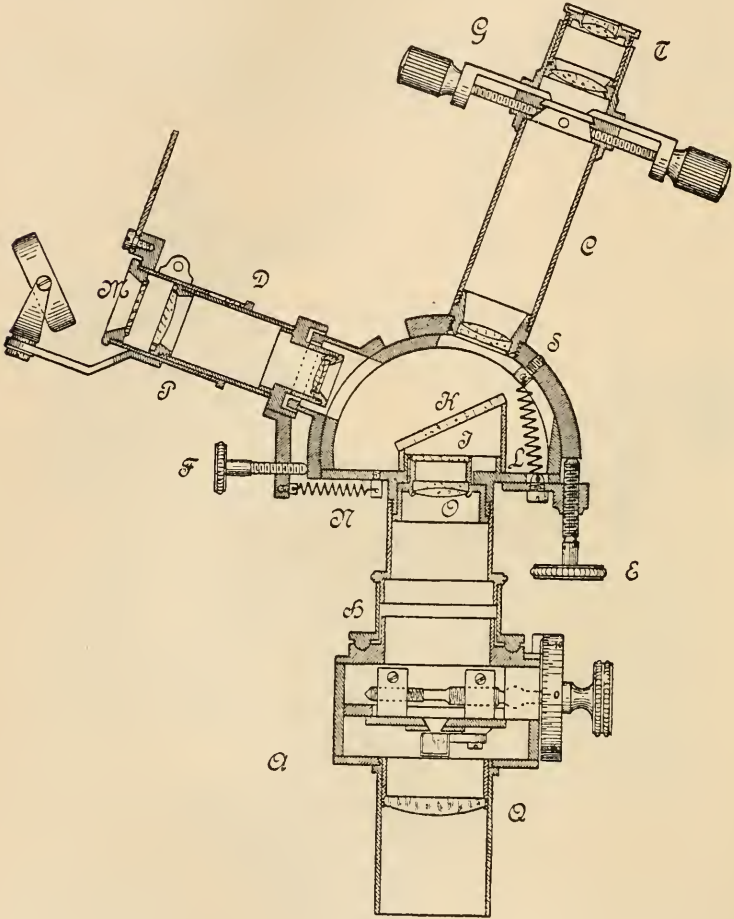

FIG. 72.

rotation of the screw E be brought over the spectrum. The four slides G on the telescope ocular serve for the delimitation of a small rectangular field for photometric comparison. The scale-tube can be accurately applied to the spectrum by means of the screw F.



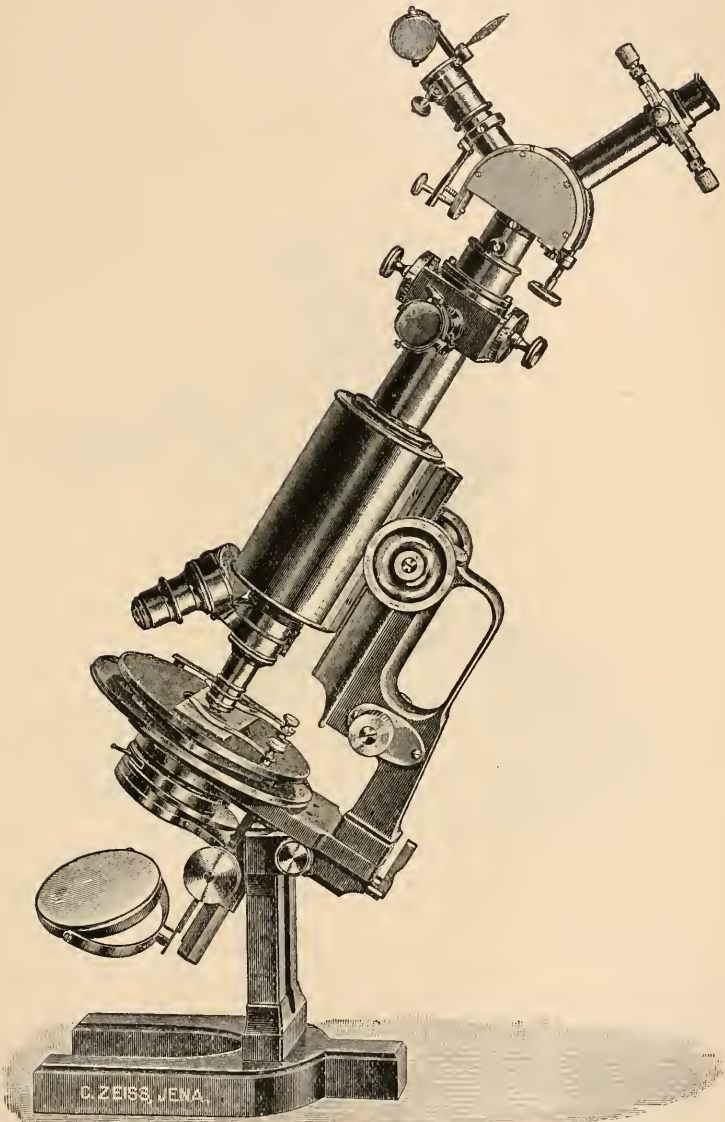

FIG. 73.

Fig. 72 gives a section through the apparatus. Over the grating J an obliquely-set small glass plate with parallel plane sides is placed, serving both for protection of the grating as well as for the reflection of the scale image. The screw E operates against the spring L, and F against the spring N. M is the rotatory wave-length scale, which the sleeve P pushes into the front focal plane of the projection ocular. The lens Q acts as the collective glass of a Huyghens ocular. The achromatic collimator objective O has a free diameter of 11 mm. and a focal

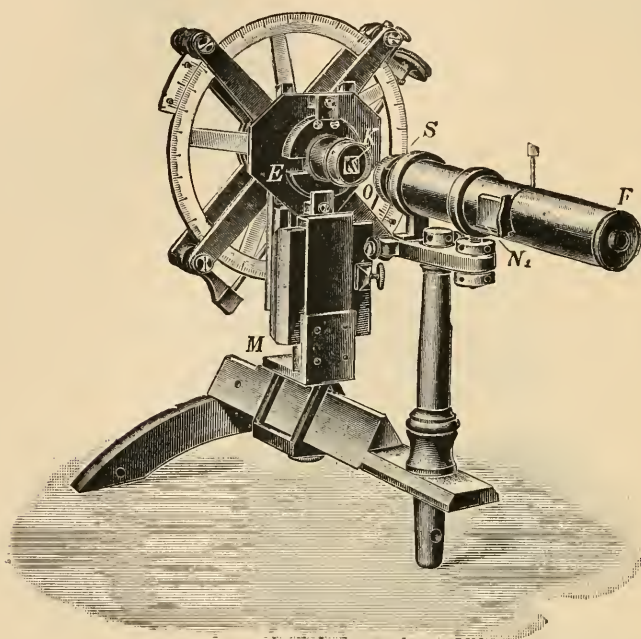

FIG. 74.

length of 50 mm. The telescope objective S is similar. The telescope ocular T magnifies about 15 times the real diffraction spectrum transmitted through the telescope objective S.

Fig. 73 shows the entire apparatus ready for use as applied to Zeiss' No. 1<sup>o</sup> stand.

**Koenigsberger's Microphotometer for the Measurement of Light-Absorption.\***—In the construction of this instrument J. Koenigsberger

\* Zeitschr. f. Instrumentenk., xxi. (1901) pp. 129-33 (2 figs.).

has arranged a diaphragm with two rectangular openings, of 3 by 5 mm. cross section, at a distance apart of 1 mm. Above this diaphragm is a calcspar rhomb 24 mm. high, whose plane-parallel faces make an angle of  $55^\circ$  with the optic axis. The transmitted rays of light undergo double refraction, and therefore form four images in the Microscope. Since the two slits are near together, both the central images partly overlap. In the real image; made by the telescope objective this position is stopped out, so that the rest of the light is screened off. In this position also the image of the one slit due to the ordinary ray coincides with the image of the other slit due to the extraordinary ray; and the illumination then consists of equal parts of polarised light, if the two openings have received equal illumination. If an absorbing substance be placed before the one opening, then the intensity of the light falling

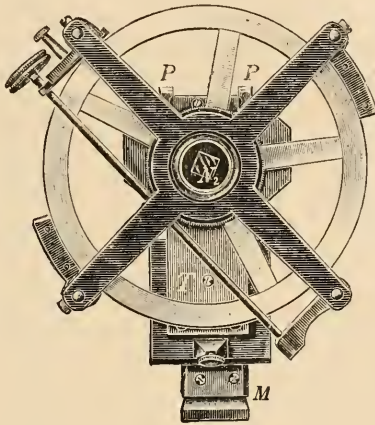

FIG. 75.

on it naturally becomes weaker than that incident on the other; and in consequence the portion of light polarised in the one direction exceeds that polarised in the other. This effect is recognisable by the occurrence of certain interference effects which are wanting in unpolarised light. The light from the other slit is now weakened in the usual manner, either by the insertion of a smoked glass wedge or by the rotation of a nicol, applied under the opening, on a divided circle whose vernier reads to minutes. This weakening is continued until both portions of polarised light again become equal and the interference effects disappear. It is, therefore, clearly on these interference effects that the adaptability of the instrument depends. In homogeneous light this interference brings out with great distinctness the bright and dark bands of a Savart's plate, and for this purpose a small telescope F (fig. 74), adjusted for infinite distance, of sevenfold magnifying power, is used. Between this telescope and the Savart's plate S a nicol  $N_1$  is

inserted in the Microscope-tube. This nicol need not be rotatory as it keeps its place unchanged, and needs be once for all orientated within  $1^\circ$  to  $3^\circ$ , until the bands attain their maximum sharpness. The Savart's plate is inserted over the Microscope objective O, either in the objective itself or in a specially rotary ring, and must be set with hard wax in such an orientation that the bands appear in the middle of the field. An achromatic lens of 6-9 cm. focus is used as the Microscope objective. The calcspar parallelepiped K of 3.0 cm. long and 1.3 by 1.3 cm. cross section, with plane-parallel faces, is fastened in a tube which is screwed on to a round brass plate of 6 mm. in thickness. At the lower end of the tube the diaphragm with the two slits is applied. In the brass plate there is a rather long incision E for the insertion and withdrawal of the smoked-glass wedge. The brass plate is fastened on to a larger plate by means of two clamps; and when these are tightened up the calcspar and slits can be pushed about until they are in the centre of the field. Under the larger plate two grooved bars P (fig. 75) are attached for receiving a frame with the substance to be examined and brought before one of the openings. On the brass foot M there is a holder T for bearing the divided circle, reading to  $5'$  and carrying a Thompson or a Leppich nicol. The axis of the Microscope can be made perpendicular, within  $\frac{1}{8}^\circ$ , to the calcspar crystal planes, either by sloping the Microscope-tube or by adjusting the crystal itself. Observations with the wedge are recommended as the most rapid. The wedge is 7.1 cm. long and has a thickness tapering from 0.35 to 0.1 cm., and on the side of its metal mount is a millimetre scale. Full instructions are given for gauging the wedge for making observations. The light-source was usually homogeneous; but sometimes, as in case of crystals, it is required to take measurements along the whole spectrum; and then a spectral apparatus similar to Wülfing's was employed, and a good Welsbach or acetylene light used.

The author,\* however, found that a considerable loss of light resulted from the use of the spectrum apparatus, and he has therefore replaced it by an arrangement which resembles an ocular spectroscope without a second slit. Between the analyser and telescope-tube he places a tube with a small upright prism, whose end-planes are inclined at about  $45^\circ$  to the microscopic axis. A second tube is set perpendicularly to the side of the first and contains a lens (focal length 3 cm.) and a glass scale, the scale being at the focus, so that scale and spectrum are seen together. He found that the brightness was then so great that, even with a small incandescent light, he could measure from  $\lambda = 0.690$  to  $\lambda = 0.430$ .

#### (6) Miscellaneous.

**Comparison of British and Metrical Measures at the same Temperature.** Computed from the coefficient given in the Report of the Standards Commission, 1871-2, by E. M. NELSON.

\* Op. cit., xxii. (1902) pp. 88-9.

in.		mm.		in.		mm.		in.		mm.	
1	·000039	1	·039382	56	2·205394	1	25·392292	$\frac{1}{16}$		1·269615	
2	·000079	2	·078764	57	2·244776	2	50·784584	$\frac{1}{8}$		1·209157	
3	·000118	3	·118146	58	2·284158	3	76·176876	$\frac{3}{16}$		1·154195	
4	·000158	4	·157528	59	2·323540	4	101·569168	$\frac{1}{4}$		1·104013	
5	·000197	5	·196910	60	2·362922	5	126·961460	$\frac{5}{16}$		1·058012	
6	·000236	6	·236292			6	152·353752	$\frac{3}{8}$		1·015692	
7	·000276	7	·275674	61	2·402304	7	177·746044	$\frac{7}{16}$		·846410	
8	·000315	8	·315056	62	2·441686	8	203·138336	$\frac{1}{2}$		·725494	
9	·000354	9	·354438	63	2·481068	9	228·530628	$\frac{9}{16}$		·634807	
10	·000394	10	·393820	64	2·520450	10	253·922920	$\frac{5}{8}$		·564273	
11	·000433			65	2·559832	11	279·315212	$\frac{11}{16}$		·507846	
12	·000473	11	·433202	66	2·599214			$\frac{3}{4}$		·461678	
13	·000512	12	·472584	67	2·638596	1 ft.	304·707504	$\frac{7}{8}$		·423205	
14	·000551	13	·511966	68	2·677978	1 yd.	914·122512	$\frac{15}{16}$		·390651	
15	·000591	14	·551348	69	2·717360			$\frac{1}{8}$	12·696146	·362747	
16	·000630	15	·590730	70	2·756742			$\frac{3}{16}$	8·464097	·338564	
17	·000669	16	·630112					$\frac{1}{4}$	6·348073	·317404	
18	·000709	17	·669495	71	2·796124			$\frac{5}{16}$	19·044219	·298733	
19	·000748	18	·708877	72	2·835506			$\frac{3}{8}$	5·078458	·282137	
20	·000788	19	·748259	73	2·874888			$\frac{7}{16}$	10·156917	·267287	
21	·000827	20	·787641	74	2·914270			$\frac{1}{2}$	15·235375	·253923	
22	·000866			75	2·953652			$\frac{5}{8}$	20·313834	·169282	
23	·000906	21	·827023	76	2·993034			$\frac{3}{4}$	4·232049	·126961	
24	·000945	22	·866405	77	3·032416			$\frac{7}{8}$	21·160243	·101569	
25	·000985	23	·905787	78	3·071798			$\frac{15}{16}$	3·627470	·084641	
26	·001024	24	·945169	79	3·111180			$\frac{1}{8}$	3·174036	·072549	
27	·001063	25	·984551	80	3·150562			$\frac{3}{8}$	9·522109	·063481	
28	·001103	26	1·023933					$\frac{5}{8}$	15·870182	·056427	
29	·001142	27	1·063315	81	3·189944			$\frac{7}{8}$	22·218255	·050785	
30	·001181	28	1·102697	82	3·229326			$\frac{15}{16}$	2·821366	·046168	
31	·001221	29	1·142079	83	3·268708			$\frac{1}{2}$	2·539229	·042320	
32	·001260	30	1·181461	84	3·308091			$\frac{1}{4}$	7·617688	·039065	
33	·001300			85	3·347473			$\frac{3}{4}$	17·774604	·036275	
34	·001339	31	1·220843	86	3·386855			$\frac{7}{16}$	22·853063	·033856	
35	·001378	32	1·260225	87	3·426237			$\frac{1}{2}$	2·308390	·031740	
36	·001418	33	1·299607	88	3·465619			$\frac{5}{8}$	2·116024	·029873	
37	·001457	34	1·338989	89	3·505001			$\frac{3}{4}$	10·580122	·028214	
38	·001497	35	1·378371	90	3·544383			$\frac{7}{8}$	14·812170	·026729	
39	·001536	36	1·417753					$\frac{15}{16}$	23·276267		
40	·001575	37	1·457135	91	3·583765			$\frac{1}{8}$	1·953253	in.	$\mu$
41	·001615	38	1·496517	92	3·623147			$\frac{1}{4}$	1·813735	$\frac{1}{16}$	25·392292
42	·001654	39	1·535899	93	3·662529			$\frac{3}{8}$	1·692819	$\frac{1}{8}$	12·696146
43	·001693	40	1·575281	94	3·701911			$\frac{1}{2}$	1·587018	$\frac{3}{16}$	8·464097
44	·001733			95	3·741293			$\frac{5}{8}$	4·761055	$\frac{1}{4}$	6·348073
45	·001772	41	1·614663	96	3·780675			$\frac{3}{4}$	7·935091	$\frac{3}{8}$	5·078458
46	·001812	42	1·654045	97	3·820057			$\frac{7}{8}$	11·109127	$\frac{1}{2}$	4·232049
47	·001851	43	1·693427	98	3·859439			$\frac{15}{16}$	14·283164	$\frac{7}{16}$	3·627470
48	·001890	44	1·732809	99	3·898821			$\frac{1}{8}$	17·457200	$\frac{5}{16}$	3·174036
49	·001930	45	1·772191					$\frac{3}{8}$	20·631237	$\frac{1}{4}$	2·821366
50	·001969	46	1·811573					$\frac{1}{2}$	23·805274	$\frac{3}{8}$	2·539229
50	·002363	47	1·850955	dm.	in.			$\frac{7}{8}$	1·493664	$\frac{1}{8}$	1·692819
60	·002757	48	1·890337	1	3·938203			$\frac{15}{16}$	1·410683	$\frac{3}{16}$	1·269615
70	·003151	49	1·929719	2	7·876406			$\frac{1}{8}$	1·336436	$\frac{1}{4}$	1·015692
80	·003544	50	1·969101	3	11·814609						
90	·003938			4	15·752812						
100	·004332	51	2·008484	5	19·691015						
200	·007876	52	2·047866	6	23·629218						
300	·011815	53	2·087248	7	27·567421						
400	·015753	54	2·126630	8	31·505624						
500	·019691	55	2·166012	9	35·443827						
600	·023629										
700	·027567										
800	·031506										
900	·035444										
1000	·039382										

1 metre = 39·38203 in.  
 = 3·281836 ft.  
 = 1·093945 yd.

## B. Technique.\*

### (1) Collecting Objects, including Culture Processes.

**Anaerobic Plate Cultures.**†—H. S. Fremlin describes a simple apparatus for anaerobic plate cultures. It consists of a circular glass chamber 5 in. in diameter and 1 in. in depth—sufficiently large to take the ordinary 11 cm. Petri dish—provided with a wide carefully ground rim. The lid of the chamber is flat and ground at the periphery where it comes into contact with the rim of the chamber. The ground surfaces which come into contact are well smeared with vaseline to secure perfect sealing of the chamber. The inoculated plate resting in the lid of the second Petri dish is placed in the chamber, and pyrogallic acid and caustic-soda solutions are then introduced, as is done in preparing a Buchner's tube anaerobic culture, and the lid secured in position. Chemical and bacteriological tests prove the efficiency of the apparatus.

**Ring Test for Indol.**‡—S. B. Grubbs and E. Francis, in utilising the acid nitroso-indol reaction, suggest the employment of the test under certain standard conditions, viz. applying the test to cultivations in fluid media containing 1 p.c. peptone, and grown for 24 hours at 37° C., in the following manner. About 8 to 10 drops of pure concentrated sulphuric acid are added to 7 c.cm. of the cultivation in a test-tube and the mixture well shaken. Three or four cubic centimetres of a 1 in 1000 sodium nitrite solution are carefully run down the side of the tube so as to form a layer on the surface of the mixture of culture and acid. In the presence of indol a pink ring at the junction of the two fluids should show up sharply and distinctly within a period of one hour—the time-limit allowed for contact.

**Differentiation of True and False Diphtheria Bacilli.**§—J. Bronstein and E. N. Grünblatt, relying on the fact that the Klebs-Loeffler bacillus produces acid quite early in the course of its growth whilst the pseudo-diphtheria bacillus produces alkali, propose to differentiate these two organisms by testing cultivations with Mankowski's reagent. This reagent is prepared by adding a mixture of 2 parts of a 2 p.c. watery solution of indigo-carmin and 1 part of a 10 p.c. solution of acid fuchsin in 1 per cent. caustic soda solution to 22 parts of distilled water. The reagent gives a ruby red colour in the presence of acid, and green in that of alkali. Cultures are made in pepton-broth with half per cent. glucose (titrated at incubation temperature with Mankowski's reagent as the indicator and rendered exactly neutral), and are incubated at the body temperature for twenty-four hours, together with uninoculated control tubes. At the end of this time about 3 drops of Mankowski's reagent are added to each tube with the result that the

\* This subdivision contains (1) Collecting Objects, including Culture Processes; (2) Preparing Objects; (3) Cutting, including Imbedding and Microtomes; (4) Staining and Injecting; (5) Mounting, including slides, preservative fluids, &c.; (6) Miscellaneous.

† Lancet, 1903, i. p. 518.

‡ Bull. 7, Hygienic Lab. U.S. Marine Hospital Service, 1902.

§ Centralbl. Bakt., 1<sup>o</sup> Abt. Orig., xxxii. (1902) pp. 425-8.

sterile broth is blue, the broth in the tube containing the Klebs-Loeffler bacillus at once assumes a ruby red colour, and that in the tube containing the pseudo-diphtheria bacillus after a few minutes becomes green. After twelve hours' further incubation, however, this last will also give a red colour.

**Differentiation of *B. coli* and *B. typhosus*.**\*—R. Zielleczkey, in differentiating *B. coli* from *B. typhosus*, employs the following medium in place of Petruschky's "Lakmusmolke": ordinary nutrient broth, in which has been dissolved 1 p.c. agar with the addition of 0.1 to 0.5 of a solution of phenolphthalein to every 5 ccm. of medium. The phenolphthalein solution is prepared by dissolving 0.5 gram phenolphthalein in a mixture of 50 c.cm. absolute alcohol and 50 c.cm. distilled water, and then diluting the fresh solution to twenty times its volume with distilled water. In this medium the *B. coli* produces a colour change in from 5 to 8 or 9 hours, whilst the *B. typhosus* does not produce any change until after about 15 hours.

**Anaerobic Cultivations.**†—D. Rivas claims to have simplified anaerobic methods of cultivation by the use of media containing sulphindigotate of soda and freshly prepared solution of ammonium sulphide. The author makes his fresh ammonium sulphide solution in a similar manner to that suggested by Hammerl,‡ and adds it in the proportion of 5 p.c. to feebly alkaline broth, gelatin, or agar containing 1.5 p.c. pepton and 1 p.c. glucose. Two cubic centimetres of a 10 p.c. solution of sulphindigotate of soda in sterile distilled water are then added to the medium per litre. Another medium employed in his experiments was prepared in a similar manner to the above, but 50 c.cm. of a 1 p.c. solution of sodium sulphide was substituted for the ammonium sulphide. This, however, did not give quite as good results.

Glass test-tubes, each provided with a constriction at the junction of its middle and lower thirds, somewhat similar to Roux's potato culture tubes, were employed in Rivas' experiments. After filling the medium into the tubes almost to the level of the constrictions and sterilising, the medium was inoculated and the upper surface of the inoculated medium covered with a layer of sterile oil to prevent access of oxygen to the culture. The author by these means was able to obtain good cultivations of the bacilli of tetanus and of malignant oedema and other obligate anaerobes.

**Differentiation of *B. typhosus* and *B. coli*.**§—Mabel P. Fitzgerald and G. Dreyer contribute a paper of extreme importance in which they describe the results of their experiments to elucidate the character of the so-called coli-reaction observed when the *B. coli* is grown in media coloured with neutral-red. They find the reaction is a quantitative and not a qualitative one, which can be obtained with Grubler's neutral-red and to a less extent or not at all with other commercial brands. Glucose-free bouillon tinted with neutral-red is a preferable medium to agar; whilst media having an acid reaction corresponding to more than 0.5 p.c.

\* Centralbl. Bakt., 1<sup>te</sup> Abt. Orig., xxxi. (1902) pp. 752-68.

† Op. cit., xxxii. (1902) pp. 831-42.

‡ See this Journal, 1902, p. 370.

§ Festschrift Statens Serum Inst. Copenhagen, 1902.

$H_2SO_4$  (phenolphthalein being used as the indicator) retard or even prevent the colour change; further, that under certain cultural conditions *B. typhosus* can produce colour reactions similar to those regarded as peculiar to the *B. coli*. The authors finally propose as a means of differentiating the *B. typhosus* from the *B. coli*, the use of a bouillon containing 3 or 4 p.c. lactose and coloured by the addition of 0.5 p.c. of a 1 p.c. watery solution of neutral red (Grubler). The reaction of this medium does not require to be accurately standardised, although a reaction corresponding to 1 p.c.  $H_2SO_4$  appears to give the best results. In such a medium the *B. typhosus* produces a yellow colour within 4 to 6 days, whilst the *B. coli* produces a red coloration, and no further change takes place even after the lapse of considerable periods.

**Enrichment Method for Typhoid Bacilli.\***—The method described by E. Altschüler depends on the specific agglutination reaction. The first step is to incubate the suspected water at  $37^\circ$  for 24 hours in a medium containing 1 p.c. peptone and 0.5 p.c. common salt. Then 10 c.cm. are pipetted into a burette, the lower end of which is fitted with a piece of rubber tubing and a clip. To the 10 c.cm. is then added immunised serum, and after about 7 hours the precipitate is passed into another tube which contains pepton-salt solution and a few sand-grains. This second tube, half the size of the former, is fitted at both ends with a piece of rubber tubing and a clamp. After an incubation of 24 hours it will be found that the typhoid germs have much increased in number.

#### (2) Preparing Objects.

**Ether as a Narcotising Medium for Aquatic Animals.†**—Hjalmar Östergren advocates the virtues of ether-water for narcotising marine or fresh-water animals. By means of vigorous shaking in a tightly corked bottle, 2 parts of ether to 25 of water (sea or fresh) an almost saturated solution of ether (7–8 p.c.) is obtained. This solution can of course be diluted to any desired extent, and as each kind of animal differs as to its susceptibility for ether it is advisable to begin with low strengths and work up to higher grades. Certain animals should be previously treated with magnesium sulphate or chloride by Tullberg's method.‡ Others which are not influenced by the magnesium salts may be treated with good result by the following device. The animals are placed in a tall vessel containing their natural water. The strong ether mixture is then poured carefully over the surface and the two layers are gradually mixed by stirring the fluids together at longer or shorter intervals. If necessary more strong ether solution may be added or even 95 p.c. alcohol.

Of course the narcotising operations should be carried out in closed vessels.

**Demonstrating the Structure of Gastropods.§**—G. Mazzarelli places the living larvæ in a test-tube containing some sea water and then

\* Centralbl. Bakt., 1<sup>o</sup> Abt. Orig. xxxiii. (1903) pp. 741–3 (1 fig.).

† Zeit.-chr. wiss. Mikr., xix. (1903) pp. 300–8.

‡ See this Journal, 1892, p. 435.

§ Rend. R. Istit. Lombardo, xxxv. (1902) pp. 719–20.



adds a few drops of 2 p.c. cocain solution. In an hour or so the animals are sufficiently anæsthetised to be studied under the Microscope. It is necessary to put a thin piece of glass or metal between the cover-slip and slide to prevent the animals from being crushed.

If it be desired to fix the larvæ the best results will be obtained from the use of Rabl's, Eisig's or Mingazzini's fluids. The formula for the last is 2 parts of saturated aqueous solution of sublimate and 1 part of absolute alcohol with the addition of 5 p.c. of glacial acetic acid. Acetic-sublimate (5 p.c. aqueous sublimate with 5 p.c. acetic acid) acts equally well. In these fluids the larvæ may be left several, even 24 hours.

If the preparations turn brown by the action of osmic acid they need not be stained but may at once be dehydrated and then passed through cedar oil (24 hours) to xylol and afterwards mounted in Grubler's neutral balsam.

For staining the preparations both *in toto* or in sections hæmalum, carmalum, hæmacalcium, Ehrlich's hæmatoxylin, and safranin were used. If they were to be stained on the slide the sections 5–10  $\mu$  thick were stuck on with water, but if already stained they were stuck with steam or by Schällibaum's method.

### (3) Cutting, including Imbedding and Microtomes.

**Fixing and Imbedding Dense Connective Tissue.\***—E. Retterer thus formulates the results of his experience :—Avoid too long immersion in alcohol, and too much heat when pieces are impregnated with paraffin. The procedure which he has found invariably to be successful is as follows. The skin is fixed in Flemming's, Zenker's or Branca's fluid, washed in water and then dehydrated in alcohol (90° for 1 hour and absolute for  $\frac{1}{2}$  hour). It is then transferred to xylol (20 minutes), and next to a mixture of xylol and paraffin at 36° (30 minutes at 20°). The object is then placed in a test-tube containing paraffin (melting-point 36°) at 40° and submitted to the action of a water pump so as to remove the air. After a quarter of an hour *in vacuo* the tissue is imbedded in paraffin at 54°. Too great heat is avoided by impregnating with liquid paraffin melted off a solid block placed in a test-tube. This step takes about 10 minutes.

**New Methods of Paraffin Imbedding.†**—V. Pranter finds that ligroin and carbon tetrachloride are very suitable solvent agents for paraffin. Ligroin, which is obtained by fractional distillation of American raw petroleum, dissolves more paraffin (melting-point 54°) at room temperature than chloroform. Carbon tetrachloride dissolves more paraffin than ligroin or chloroform, but less than carbon sulphide; it is, however, not poisonous or inflammable like the latter. The objects, which have been fixed in alcohol, are placed in thin cedar oil for 12 hours, after which they are transferred to fresh oil for another 12 hours, by which time they are quite transparent.

The pieces are next placed in ligroin or carbon tetrachloride for at

\* Journ. Anat. et Phys., xxxix. (1903) p. 196.

† Zeitschr. wiss. Mikr., xix. (1903) pp. 329–32.

least 12 hours, then for another 12 hours in a saturated solution of paraffin in ligroin or tetrachloride. These preceding stages are carried out at room temperature. The pieces are now placed in a thermostat at 58° for about half an hour, and then transferred to liquid paraffin (melting-point 54°-56°). The last step is repeated, and then after about 3 to not more than 6 hours the preparations are imbedded in paraffin (melting-point 54°-56°). The blocks obtained by this method allow very satisfactory sections to be cut from them, and crumpling is slighter and less frequent than by the ordinary imbedding methods.

**Carbon tetrachloride as a Clearing Fluid.\***—J. Plečnik points to the inflammability of carbon bisulphide as a great objection to its use as the clearing medium for tissues that are to be imbedded in paraffin, and also mentions the fact that it causes disintegration of nuclei stained with osmium.

The author tried petroleum-ether for the purpose, but found that though better in some respects, it was equally inflammable and did not yield such easily cutting tissues as carbon bisulphide. He therefore advocates the employment of carbon tetrachloride as the clearing medium in such cases, as it is not open to either of the objections urged against carbon bisulphide, nor does it interfere with the easy cutting of thin sections from the imbedded tissues, though the results are not quite so satisfactory as with carbon bisulphide.

#### (4) Staining and Injecting.

**Differential Stain of *B. Diphtheriæ*.†**—J. W. Peck suggests the substitution of Loeffler's (alkaline) methylen-blue for the acetic acid methylen-blue usually employed in Neisser's differential method. The author states that it is more reliable in swabbings and in cultures, shows the differential staining equally well in recent and in old cultivations, and, moreover, has the advantage of never staining either the bacillus of Hoffmann or the *B. corycæ segmentosus*.

**Flagella Staining.‡**—G. de Rossi cleans the cover-glasses with alcohol, then puts them for 10 to 15 minutes in boiling sulphuric acid, washes repeatedly in water, immerses in a mixture of equal parts of alcohol and benzoin, wipes them with a clean cloth, and finally flames them 40 to 50 times over a Bunsen burner. The films should be made from agar cultures 8 to 12 hours old at 37°, or 18 hours old at 15° to 20°. Before using a culture it should be examined in a hanging-drop in order to ascertain if the bacteria are sufficiently motile. If so, then a particle from the culture is removed by means of a platinum loop, and mixed with a droplet of water on a slide. From the emulsion a loopful is removed to a watch-glass, in which has been placed some 10 to 15 drops of distilled water. After stirring the emulsion and the water up together a little drop is removed on a loop and placed on the centre of a cover-glass. It is not spread out, but is allowed to dry in the air or in an exsiccator. The films are not fixed. For the staining three solutions are required :—(A) consists of 50 grm. pure carbolic

\* Zeitschr. wiss. Mikr., xix. (1903) pp. 328-9.

† Lancet, 1903, i. p. 92.

‡ Centralbl. Bakt., 1<sup>o</sup> Abt. Orig., xxxiii. (1903) pp. 572-6.

acid, 40 grm. of tannic acid, and 1000 grm. of water; (B) of 2·5 grm. basic fuchsin, and absolute alcohol 100 c.cm.; (C) of potassium hydrate 1 grm., and distilled water 100 grm. Solutions A and B are mixed together and kept in a tightly corked bottle. When required for staining, solution C is added drop by drop to the A B mixture until a dusty looking precipitate can be seen at the margin. The fluid is then filtered and 4 or 5 drops of the clear filtrate poured over the prepared film. The staining fluid becomes, after a variable time, iridescent, then turbid, and finally deposits a precipitate. When this last stage occurs the flagella are stained. The preparation is then washed with distilled water and dried with blotting-paper.

**Demonstrating Trypanosomata.\***—M. Elmassian and E. Migone, when studying the "Mal de Caderas," a disease of South American Equidae, used the following solutions:—(A) Hæmatein 0·5 gr., ammonia alum 5 grm., water 100 c.cm. (B) Magenta red 1 grm., absolute alcohol 10 c.cm., water 100 c.cm. The Trypanosoma blood was spread on slides and fixed first in absolute alcohol for 12 hours, and then in 5 p.c. bichromate of potash for 1 to 3 hours. The films having been carefully washed in tap water, were stained for a quarter of an hour or more in a mixture of the two solutions (5 c.cm. of the first and a drop of the second). Sometimes it was found better to use the staining separately and successively instead of simultaneously. In this way a better hæmatein effect is attained without overstaining with magenta. The addition of 20 to 30 grm. p.c. to the hæmatein solutions was often an improvement. Stained in this way the nucleus of Trypanosoma is violet, the flagellum dark red, the protoplasm dull red, and the membrane bright red. This method also demonstrates the presence towards the blunt end of a spherical body (micronucleus, centrosome) which is of variable size and is invariably connected with the flagellum or filament.

**New Glass Staining-Trough.†**—J. Schaffer describes a glass trough which he has found useful for staining series of sections on slides of the English or Vienna shape. The measurements are 9 by 8 by 5 cm. The trough is provided with a lid and will accommodate 10 (or 20 placed back to back) slides in the long direction and 12 (or 24) in the short. Except in shape and adaptability to two kinds of slides this apparatus does not differ materially from many other staining troughs.

**Method for Staining Bacterial Granules.‡**—M. Ficker advises the use of a solution composed of methylen-blue (med. pur. Höchst) and lactic acid 2 p.c., for staining bacterial granules. A suspension of bacteria in tap-water is placed on a slide and a drop of the solution is run under the cover-glass in the usual way. This may be repeated several times, with an interval of some minutes between the turns.

**Staining and Preservation of Serial Sections on Paper Strips.§** A. Schoenemann describes the following procedure which he adopts for

\* Ann. Inst. Pasteur, xvii. (1903) pp. 243-4 (1 pl.).

† Zeitschr. wiss. Mikr., xix. (1903) pp. 297-300 (1 fig.).

‡ Hyg. Rundschau, xii. (1902) p. 1131.

§ Zeitschr. wiss. Mikr., xix. (1903) pp. 336-6.

staining and mounting serial sections. The sections are stuck on strips of non-colourable paper, the ordinary celloidin sections being taken out of 90 p.c. alcohol, while the paraffin and dry celloidin sections are treated as they are. After the strips have been allowed to dry in the air for a quarter of an hour, they are placed in xylol or in a mixture of equal parts of chloroform and 90 p.c. alcohol. After having been mopped up with filter-paper the strips are immersed in 90 p.c. alcohol. After being pressed again between folds of filter-paper the strips are put in distilled water, and from this to dilute hæmatoxylin solution (hæmalum, Delafield's, &c.). After a thorough washing the strips are transferred to eosin-alcohol (90 to 95 p.c. alcohol) from which they are passed through carbolxylol to xylol. The strips may be kept in xylol, paraffin oil, or in cedar oil.

**Method for Demonstrating Cartilaginous Micro-Skeletons.\*—**

J. W. van Wijhe makes permanent preparations for demonstrating the cartilaginous skeleton of embryos by the following method. The embryo is fixed in 5 p.c. sublimate solution, or 10 p.c. formol, or in Zenker's fluid, and is preserved in alcohol. Before staining, the object is immersed for a day or two previously in acid-alcohol ( $\frac{1}{4}$  p.c. HCl) and this must be renewed if it has turned yellow next day. After the acid-alcohol bath, the object is placed for a day, or better for a week, in an alcoholic solution of methylen-blue to which 1 p.c. hydrochloric acid has been added. The blue-stained object is then immersed in acid-alcohol, renewed several times on the first day and once daily afterwards. The renewal is continued until the alcohol shows no blue tinge the next day.

In about a week the stain has been removed from all the tissues, except from the fundamental substance of the cartilage. The object is then dehydrated in absolute alcohol and clarified in xylol. This last procedure is done gradually in order to prevent wrinkling: the first stage being 2 parts alcohol to 1 of xylol; the second, 1 part alcohol to 2 of xylol; and the third, pure xylol. After this the objects are put first in a thin, afterwards in a thick solution of balsam in xylol, and finally in a solution which at ordinary temperature is solid, but liquid at 60°. In this solution they are kept in a thermostat at 60° for a couple of hours, and are then enclosed in glass cells under a cover-glass. The ordinary glass cells are usually too low, but higher ones are easily made by fixing strips of window-glass on a slide with balsam.

**Method for Staining Sputum for Bacteriological Examination.†—**

W. H. Smith describes the following method. Solutions needed:—anilin-oil-gentian violet, Gram's iodine, saturated aqueous solution of eosin, Locffler's alkaline methylen-blue, mixture of 95 p.c. alcohol 4 parts and ether 6 parts, 95 p.c. alcohol, absolute alcohol, xylol.

The films should be made from fresh sputum to which neither carbolic acid nor corrosive sublimate has been added. The film is fixed in the flame in the usual way. Then drop on some gentian-violet and heat till it vaporises; wash off I.K.I.; put on more I.K.I. and heat;

\* K. Akad. Wetensch. Amsterdam, Proc. Sect. Sci., v.(1902) pp. 47-51.

† Boston Med. Surg. Journ., cxlvii. (1902) pp. 659-62.

decolorise with 95 p.c. alcohol ; wash in the alcohol-ether mixture, wash with water, stain for a few minutes with eosin, wash off excess with Loeffler's solution. Drop on more methylen-blue solution and heat ; decolorise with 95 p.c. alcohol, wash in absolute alcohol, treat with xylol, and mount in balsam.

(5) Mounting, including Slides, Preservative Fluids, &c.

STRASSER, H.—Die Nachbehandlung der Serienschritte auf Papier-unterlagen. (The after-treatment of serial sections on paper-underlays.)  
*Zeitschr. wiss. Mikr.*, XIX. (1903) pp. 337-45.

(6) Miscellaneous.

**Encyclopædia of Microscopical Technique.\***—The recent issue of the *Encyclopædia of Microscopical Technique* is an event of great importance in the world of microscopical literature. The work appears in two volumes comprising together some 1400 octavo pages, and whilst appealing primarily to the medical microscopist contains much that is interesting and valuable as well as instructive to the technical student and also to the amateur. The Encyclopædia is devoted solely and entirely to descriptions of apparatus and methods, and the articles, numbering several thousands, vary considerably in length—many extending to thirty, fifty, or even more pages—and form masterly treatises in their respective subjects. Many articles are signed, and wherever the importance of the subject demands such additions, a fairly complete bibliography is appended. The printing and paper are good ; the subject headings being printed in larger and blacker type render it an easy matter to find any desired article.

Illustrations are scattered through the pages to the number of about 130 in the two volumes. These form perhaps the only disappointing feature of the Encyclopædia, consisting for the most part of woodcuts of apparatus and diagrams culled from the catalogues of various microscopical instrument makers. Within the pages of this Encyclopædia are to be found minute details of all the various methods of microscopical research, in all its various branches, histology, pathology, zoology, botany, bacteriology, &c., some of the most important being those on fixation by von Tellyesniczky, injection by Prof. Hoyer, paraffin and paraffin imbedding by Neumayer, serial sections (celloidin) by Helbing, photomicrography by Zoth. The various stains and chemical reagents employed in microscopical work, such as corrosive sublimate, osmic acid, iodine, chromic acid and its salts, are also carefully described and their special applications fully discussed.

Embryology is well catered for, two papers in particular, *Embryological Technique and Methods of Experimental Embryology*, by Prof. Ballowitz and Dr. Wetzel respectively, being worthy of careful perusal.

Special methods of staining too are very fully and carefully treated,

\* 'Encyklopädie der Mikroskopischen Technik mit besonderer Berücksichtigung der Färbekunst, herausgegeben von P. Ehrlich, M. Mosse, R. Krause, H. Rosin und C. Weigert,' Berlin and Vienna, 1903, 2 vols., 1400 pp., with illustrations.

notably, silver methods by Dr. Mosse, gold methods by Prof. Szymonowicz, Golgi's method and its modifications by Prof. Kallius.

The methods applicable to various special tissues such as the sense-organs, and especially the nervous system, are very fully described. From even the few articles we have indicated it will be seen that the work under notice is a veritable storehouse of exact information, and forms an invaluable adjunct to the laboratory equipment of the working microscopist; and we feel certain that as such it will be warmly welcomed and heartily appreciated.

**Eyre's Bacteriological Technique.\***—It is difficult to praise too highly J. W. H. Eyre's *Elements of Bacteriological Technique*. Though it claims only to be a laboratory guide for the medical, dental, and technical student, it is much more than this, and no doubt its practical usefulness will be appreciated by many superintendents of bacteriological and clinical laboratories. The author describes with unusual clearness the apparatus, methods, media, &c. required for the detection and demonstration of microbes in the living and the dead, and in earth, air, and water. These descriptions are aided by numerous illustrations, nearly all of which have been prepared specially for this volume, and about which the author cogently remarks that a good picture possesses a higher educational value and conveys a more accurate impression than a page of print. Besides technique there are chapters dealing with the morphology of the Hyphomycetes and Blastomycetes, and with the anatomy, physiology, and biochemistry of the Schizomycetes; while another section gives the outlines for the study of pathogenic bacteria. There is no doubt that this work will appeal strongly to medical and dental students, but it ought also to technical students generally, for it contains all the laboratory information and instructions requisite for brewing, dairying, and agriculture. Though the limits of our space prevent us from doing justice to this eminently practical guide, we may express the conviction that it will be highly appreciated and extremely successful.

**KRAUS, R.**—Ueber eine neue regulierbare Vorrichtung für den heizbaren Objektisch. (An apparatus for keeping the water on the hot stage at a constant temperature.) *Centrallbl. Bakt.*, 1<sup>te</sup> Abt. Orig. XXXII. (1902) pp. 467-9 (1 fig.).

“ “ Ueber einen Apparat zur bakteriologischen Wasserentnahme. (An apparatus for obtaining water for bacteriological examination.)

*Tom. cit.*, pp. 469-71 (2 figs.).

#### Metallography, &c.

**Microscopic Appearances of Volcanic Dust.†**—T. Andrews, in a lecture given at the University of Cambridge, demonstrated the magnetic properties of volcanic dust and the effect of polarised light thereon. The author also described the appearance of the volcanic dust ejected from Mont Soufrière, St. Vincent Island. This dust consisted of minute particles of varying size, the majority being more or less transparent. The largest grains seemed mostly to consist of volcanic glass, in which gas was frequently occluded in internal cavities. The medium-sized

\* W. B. Saunders & Co., Philadelphia and London, 1902, 371 pp., 170 figs.

† Engineering, lxxv. (1903) pp. 195-9.

particles appeared also to consist of volcanic glass together with felspar crystals, while the small-sized dust was mostly mineral crystals or their disintegrated fragments. Some of the larger particles appeared to be of the nature of a greenish volcanic glass; there were also crystals or fractured portions of crystals apparently of felspar and quartz. A noticeable feature was the presence of some partially transparent particles of greenish-brown tint which seemed to indicate the presence of olivine, and sometimes brown coloured semitransparent glassy particles were noticed. Many of the transparent crystals manifested a sharpness on their edges, but others were more or less rounded. When viewed with polarised light, the effect on some of the crystalline particles was very fine. In some of the glassy crystals were noticed numerous internal cavities seemingly enclosing volcanic gases. Some of these particles which did not transmit light appeared to be of the nature of the magnetic oxide of iron. The paper is illustrated by eighteen photomicrographs, thirteen of which give the appearances in the dust from Mont Soufrière, four of the dust from Cotopaxi, and one, that of volcanic iron crystals.

**Analysis of Steel-Works Materials.\***—H. Briarley and F. Ibbotson have produced a valuable work on this subject, and have striven to include only those methods of analysis which have been verified and tested by the authors themselves or have been done under their supervision. Parts i.—x. (282 pp.) deal with the chemical aspects of analysis, and part xi. with the Micrographic analysis of steel. This latter section, which will naturally be the most interesting part of the book to microscopists, deals with the following details:—Preliminary preparations, Methods of polishing, Etching the specimens, Heat-tinting, Rapid method of preparation, Mounting, Microscopic accessories, Photography. The final division, treating of the Microstructure of steel, is subdivided into pure iron-carbon steels, manganiferous steels, and steel castings. There are about fifty photomicrographs embracing a great variety of types of steels, and a copious bibliography. Part xii. deals with pyrometry, part xiii. with miscellanea. An appendix with a bibliography of steel-works analysis concludes the work.

**Certain Properties of the Alloys of the Gold-Silver Series.†**—W. C. Roberts-Austen and T. K. Rose have found that it is preferable to use only silver as the alloying metal with gold in the manufacture of trial plates. Such an alloy has accordingly been used at the Royal Mint since the beginning of the present year, instead of fine gold, for checks in the assay of standard bars and coins. In view of the minute accuracy with which the operations of coinage have to be conducted, this is a matter of much importance. By this method any errors are avoided which might be caused by accidental variations in weights occurring after the trial plates have been made.

\* Longmans, Green & Co., London, 1902, 501 pp.

† Proc. Roy. Soc., lxxi. (1903) pp. 161-3 (3 figs.).

## PROCEEDINGS OF THE SOCIETY.

## MEETING

HELD ON THE 15TH OF APRIL, 1903, AT 20 HANOVER SQUARE, W.  
DR. HENRY WOODWARD, F.R.S., PRESIDENT, IN THE CHAIR.

The Minutes of the Meeting of the 18th of March, 1903, were read and confirmed, and were signed by the President.

The List of Donations to the Society, exclusive of exchanges and reprints, received since the last Meeting, was read, and the thanks of the Society were voted to the donors.

	From
Beck and Andrews, Photographic Lenses, 3rd edition. (32mo, London, 1903) .. .. .	} <i>The Authors.</i>
Lafar, Franz, Technical Mycology. Translated by Chas. T. C. Salter. Vol. ii, part i. (8vo, London, 1903) .. .. .	} <i>The Publishers.</i>
Quarterly Journal of the Geological Society, Nos. 1, 4, 6, 8, 10, 13-55. (8vo, London, 1845-1858) .. .. .	} <i>The Society.</i>
An old Microscope by Dollond .. .. .	} <i>Mr. Wynne E. Baxter.</i>

Mr. C. F. Rousselet exhibited a series of 22 slides of mounted Rotifers of the genus *Brachionus*, comprising 16 different species, of which one is as yet undescribed, and four varieties. He said that 69 species of *Brachionus* in all had been described, but he thought it was probable that about half of these were synonyms or varieties. He then gave some particulars as to the characters and habitats of the specimens exhibited, and where they came from: England, Germany, Bohemia, Hungary, Syria, Hong Kong, and America. Incidentally, he also mentioned that the *Brachionus rubens* exhibited, which is mostly found semi-parasitic on *Daphnia pulex*, was the true species of Ehrenberg, and different from the species figured under that name in Hudson and Gosse's monograph.

The President said they were greatly indebted to Mr. Rousselet for arranging this very interesting exhibition, and thought he had done well to confine it to specimens of one genus for the sake of comparison between the different species. They were also further indebted to Messrs. Watson for the loan of the Microscopes for the purposes of this exhibition. Votes of thanks to Mr. Rousselet and to Messrs. Watson were put from the chair and carried unanimously.



A paper by Mr. F. W. Millett—being the fourteenth of his series “On the Foraminifera of the Malay Archipelago”—was by consent of the Meeting taken as read, and the thanks of the Society were voted to the Author.

Mr. E. B. Stringer’s paper “On a new Method of using the Electric Arc in Photomicrography” was read by Dr. Hebb, and lantern-slides in illustration of the subject were subsequently shown upon the screen.

Votes of thanks to the Author and to the reader of the paper were, upon the motion of the President, unanimously carried.

A communication by Mr. Hamlyn-Harris “On an Apparatus for facilitating the manipulation of Celloidin Sections” was read by Dr. Hebb.

The thanks of the Society were voted to the Author of this communication.

The President reminded the Fellows that in accordance with the notice given at the last Meeting of the Society, Mr. Fletcher would be very pleased to receive any of the Fellows of the Society on Saturday, April 18, at the Natural History Museum, and to conduct them round the Mineral Department to explain the chief features of the collection under his charge. He was quite sure that those who attended would find that Mr. Fletcher had some very interesting information to give them, and that he had a very pleasant way of imparting it. The party would meet, as on former occasions, at the Owen statue at 2 o’clock p.m.

The following Instruments, Objects, &c., were exhibited:—

The Society:—An old Microscope by Dollond.

Mr. C. F. Rousselet:—Twenty-two slides of mounted Rotifers of the genus *Brachionus*:—*B. aculeatus* sp. n., from Hertford Heath; *B. anguluris*; *B. bakeri*; ditto, var. some with very short spines and some without spines, from Hanwell; ditto, var. with very long spines, from Illinois river, America; *B. budapestinensis* (Daday) = *B. punctatus* Hempel, from America; *B. caudatus*, from America; *B. dorcas*, from Kew Gardens; *B. falcatus*, from Bohemia; *L. forficula*, from Asia Minor; *B. militaris*, from Hong Kong; *B. mollis*, from America; *B. mülleri*, from Great Yarmouth; *B. pala*, ♂ and ♀; ditto, var. with very long posterior spines; ditto, very large variety from Norfolk Broads; *B. quadratus*; *B. rubens*, ♂ and ♀; ditto, commensal on *Daphnia pulex*; *B. urceolaris*, ♂ and ♀; *B. variabilis*, from America; *Schizocerca* (*Brachionus*) *diversicornis*, from Germany.

## MEETING

HELD ON THE 20TH OF MAY, 1903, AT 20 HANOVER SQUARE, W.  
DR. HENRY WOODWARD, F.R.S., PRESIDENT, IN THE CHAIR.

The Minutes of the Meeting of the 15th of April, 1903, were read and confirmed, and were signed by the President.

Mr J. J. Vezey said that reference had been made to the kindness of Mr. Fletcher in conducting a party of the Fellows of the Society through the Mineral Department of the Natural History Museum, on April 18th, and as one of those who attended on that occasion, he should like to publicly express his indebtedness and that of the Society for the attention shown to them during the two hours which were occupied in taking them round the gallery and pointing out and explaining the specimens exhibited. He therefore moved: "That the warmest thanks of the Society be given to Mr. Fletcher for his kindness and courtesy to the Fellows of the Royal Microscopical Society on the occasion of their visit to the Mineral Department of the Natural History Museum." The motion having been seconded by Mr. K. J. Marks, was put to the Meeting by the President and carried unanimously.

The List of Donations to the Society, exclusive of exchanges and reprints, received since the last Meeting, was read, and the thanks of the Society given to the donors.

	From
Eyre, J. W. H., <i>The Elements of Bacteriological Technique.</i> (8vo, London, 1902) .. .. .	} <i>The Author.</i>
An Early Compound Microscope .. .. .	} <i>Mr. E. M. Nelson.</i>
An Old Microscope by Carey .. .. .	}

Special attention was called to the work on *Bacteriological Technique* by Dr. Eyre, one of the assistant editors of the Society's Journal; also to the two old Microscopes, one of which was an instrument by Carey, and the other an extremely old specimen of a compound Microscope with the mirror attached to the limb, of which a description by Mr. E. M. Nelson was read to the Meeting.

Mr. C. L. Curties exhibited and described a new Monochromatic Light Apparatus, which was a modification of that suggested by Dr. Spitta and exhibited by him at the Meeting of the Society in November 1902.

It consisted of an optical bench upon which were mounted an electric lamp of the Nernst pattern, an aplanatic bull's eye condenser with centring adjustments, an adjustable slit, an achromatic collimating lens, a prism upon which was mounted one of Thorp's replica gratings, and

an achromatic projection lens ; the whole being fitted upon a mahogany base capable of being tilted.

The usual heating coil of the Nernst lamp had been removed and the filament was heated by the temporary application of the flame of a spirit-lamp, the carrier of the electric lamp being so arranged that the spirit-lamp could be applied when required, and the opening closed when necessary. The lamp was also fitted with centring screws to enable the filament to be brought into the optic axis. The whole of the optical bench could be readily moved by means of a tangent screw, enabling any part of the spectrum to be brought into the field of the Microscope.

In setting up the apparatus it had been found most convenient to bring the adjustable slit and the electric light into the optic axis of the Microscope by viewing the images of these through the substage condenser, the prism, &c. could then be put into position, and by focussing the light by means of the aplanatic bull's eye a brilliant beam could be directed upon the slit. It had also been of advantage to have a small slit a few inches from the substage, as a sharp image of the spectrum could then be projected on to this. The diatoms shown by this method of illumination under a high-power apochromatic objective exhibited the markings with exceptional sharpness of definition, which elicited high commendation from those who examined them.

The thanks of the Society were voted to Mr. Curties for his exhibit and explanation.

---

**Messrs. W. Watson & Sons** exhibited a new form of Museum Microscope fitted inside a locked glass case through which the eye-piece tube projects. The circular stage contains 12 objects and can be rotated from the outside of case.

A projecting milled head provides the means of focussing, the arrangement of the latter being such that all danger to object or objective by an unskilled observer is avoided.

The instrument is intended for use with low powers—and a polariscope attachment can also be fitted.

Messrs. Watson also exhibited a simple form of Stand Condenser of long focus, furnished with an iris diaphragm, also adjustments to the horizontal and vertical movements.

The President thought that the small Microscope for museum use, exhibited by Messrs. Watson & Sons, was an extremely useful arrangement for the purpose, resembling a similar form of instrument which had been adopted at the Smithsonian Museum at Washington. The object of this contrivance was to enable even children to see microscopic objects without handling them, and he thought if it was introduced to the notice of the directors of museums here it would be sure to "take on." There was at the Natural History Museum an arrangement by which certain Foraminifera could be seen magnified by a lens, but this was so placed as to be in a rather uncomfortable position to look through, and certainly in no way comparable for convenience with the one now before them, by which a dozen objects could be viewed in succession. Of course there was a great difference between the conditions at the Washington Museum, where perhaps only a few dozen people passed through in the

course of a day, and those at South Kensington, where sometimes several hundreds of Board School children passed through the galleries on a Bank holiday, bringing their luncheons with them and smearing the glass cases with sticky fingers. The desirability of some kind of protection for a Microscope under those circumstances would be obvious.

The thanks of the Society were given to Messrs. Watson & Sons for sending these instruments for exhibition.

---

The President called attention to the very fine exhibition of living objects shown under Microscopes in the room by Members of the Quekett Club and Fellows of the Society, to whom their best thanks were due.

---

The following Objects, Instruments, &c., were exhibited :—

The Society :—An early Compound Microscope, with mirror attached to the limb; and an old Microscope, supposed to be by Carey, presented by Mr. Nelson.

Mr. C. Baker :—New Monochromatic Light Apparatus, and *Navicula rhomboides* under monochromatic light.

Messrs. Watson & Sons :—Two Museum Microscopes; Bull's-eye n denser, with iris diaphragm and centring adjustments.

Mr. J. W. Chapman :—*Triphylus lacustris*.

Mr. Alfred W. Dennis :—*Conochilus volvox*.

Mr. G. P. Dineen :—*Daphnia*.

Mr. T. D. Ersser :—*Hydra vulgaris*.

Mr. A. J. French :—*Eurycerus lamellatus*.

Mr. Alfred E. Hilton :—*Stentor niger*.

Mr. E. Hinton :—*Cristatella mucedo*.

Mr. J. T. Holder :—*Gammarus pulex*.

Mr. K. J. Marks :—*Brachionus pala*, *Dinocharis porcellum*, *Proales parasita*, *Rhinops vitrea*, *Syncheta pectinata*, *S. tremula*.

Mr. W. J. Marshall :—*Corethra plumicornis*, larva.

Mr. Max Poser :—*Melicerta ringens*.

Mr. T. H. Powell :—*Volvox globator*.

Mr. J. Rheinberg :—*Stephanoceros eichhorni*.

Mr. G. H. J. Rogers :—*Lophopus crystallina*.

Mr. C. F. Ronselet :—*Cristatella mucedo*, young; *Conochilus volvox*, *Hydatina senta*, *Notops brachionus*, *Rhinops vitrea*.

Mr. D. J. Scourfield :—*Eurytemora lacinulata* ♂ ♀, a rare fresh-water copepod.

Mr. C. J. H. Sidwell :—*Eurytemora lacinulata*, male right antenna, showing roughened processes on the thickened joints, used as sexual clasping organ; and showing also sense-hairs.

Mr. C. D. Soar :—*Sperchon glandulosus*, new to Britain.

Mr. J. H. A. Verinder :—*Stephanoceros eichhorni*.

Messrs. W. Watson & Sons :—*Lacinularia socialis*.

Mr. Chas. West :—*Stephanoceros eichhorni*.

JOURNAL  
OF THE  
ROYAL MICROSCOPICAL SOCIETY.  
AUGUST 1903.

---

---

TRANSACTIONS OF THE SOCIETY.

---

VI.—*The Helmholtz Theory of the Microscope.*

See Pogg. Ann., 1874, Jubelband, p. 569. Helmholtz' *Wissenschaftliche Abhandlungen*, vol. ii. p. 185. Proceedings of the Bristol Naturalists' Society, N.S. vol. i. part 3. Monthly Microscopical Journal, N.S. vol. xvi. p. 15. See also Appendix, Note iv.

By J. W. GORDON.

(*Read March, 18th, 1903.*)

PLATE VI.

HELMHOLTZ' paper bears the title, 'The Theoretical Limits of Resolving Power in the Microscope,' and is directed to the formal conclusion that a certain defined magnitude forms the necessary and impassable limit of resolving power in the Microscope or in any other optical instrument. But it will, I think, be found that the merit of the paper lies not in this formal result, which is, in fact, not successfully established, but in the line of investigation which Helmholtz here strikes out, and without following it to its practical issues, pursues far enough to present his readers with a surfeit of interesting and valuable suggestions. These suggestions are, many of them, so obscure and conveyed by such subtle hints that they may well escape attention, and apparently they have escaped attention to the present time. It will be my endeavour this evening to bring the Helmholtz method of investigation to your notice, and to divest it of its somewhat repulsive mathematical garb in order that it may be rendered by translation into physical terms more presentable in general society. I shall also ask leave to apply the results of this investigation to certain practical matters connected with the construction and use of the Microscope,

*Aug. 19th, 1903*

2 c

thus evolving what may fairly be called the Helmholtz theory of the instrument.

Stated very roughly, the Helmholtz method of investigation may be described as the use of wave-fronts as instruments of research. It rests on this assumption, almost a self-evident proposition, that any instrument which is capable of giving a regular image of any surface whatever must be capable of giving a similar image of any wave-front which can be made to coincide with that surface, and pass through the instrument. The ordinary geometrical method of investigation deals with separate rays and radiant points only. It results, as we all know to our cost, in the most intricate mathematics before we have proceeded far along any line of research. Helmholtz substitutes for these elements the elementary notion of radiant surfaces which move backwards and forwards through the instrument, and by noting what happens at various points to these travelling surfaces, he investigates the relations of various parts of the instrument to one another. The conception of the travelling radiant surface may perhaps seem a little unfamiliar, but it is fully warranted by the undulatory theory of light, and, in fact, produces the most enormous simplification in the discussion of many problems of optics.

The radiant surfaces with which we are here concerned, are not only wave-fronts. A wave-front is defined to be a surface disturbed by wave-motion in such wise that all parts of the surface move in unison, that is to say, that all parts of the surface exhibit the same phase of the undulation at any one and the same instant of time. It may be described briefly as an uniphasal surface. This is, in fact, strikingly unlike the front of an advancing wave, as we see it in the ocean, for example. Such a front-of-a-wave is a surface in which a complete half-series of undulation-phases is to be discovered. At its foot in the trough of the wave the water is in a state of momentary rest in its lowest position; as we climb the front we find the water getting gradually into a swinging motion, swinging upward, and at a point half-way up the front of the wave this upward motion of the water is at its fastest. From that point to the crest, the rising motion grows less and less rapid, and when the crest is reached the upward movement is exhausted and the water comes momentarily to rest in its topmost position. Now, this is not a "wave-front" in the technical sense of the term, for it is a polyphasal surface, whereas a wave-front is by definition uniphasal. But with such polyphasal surfaces, the theory of resolution in the Microscope is much concerned, for whereas uniphasal surfaces, or wave-fronts, give rise to the direct, or, as they are termed, the dioptric beams in an optical instrument, the diffracted beams arise from polyphasal surfaces and therefore the law of their refraction is of equal importance with the law of the refraction of uniphasal surfaces. The diagram fig. 76 will

illustrate this point. Here, we have the path of a train of plane wave-fronts indicated by thirteen sections denoting successive phases of three complete undulations. The phases of rest are denoted by the section lines *t* (trough) and *c* (crest) respectively.

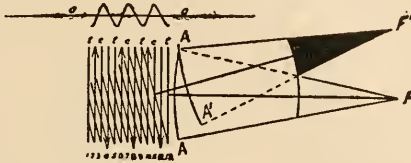

FIG. 76.

The intermediate positions of most rapid motion upward and downward are denoted by section lines shown with arrow-heads, and a wavy curve at the top of the diagram indicates for a particular instant of time the simultaneous displacement of a series of particles forced by the wave motion away from their normal position on the zero-line *o . . . o*.

Now, suppose that by some refracting contrivance we force the plane wave-fronts when they reach a certain plane *A* to assume a spherical form with a radius of curvature equal to the distance *A F*. Then *F* will become the focus of the beam of light, and if we assume a single particle of tangible matter to be set in motion at that point by the luminiferous oscillations, it is obvious that the index particle will be kept in a state of rhythmic movement as long as the beam of light continues to flow, that is to say, as long as the light shines through the aperture *A A*. And the movement will not only be rhythmic, it will be violent in proportion to the area of the wave-fronts that pass the aperture, for since these wave-fronts condense upon the particle and impart the whole of the energy which they individually carry in a single blow, the amount of the energy so imparted must be exactly proportional to the area of the wave-front which carries it. When the wave-front and the aperture coincide, the disturbance of the particles will be proportional to the area of the aperture itself.

Now consider the case of the polyphasal surface drawn upon the diagram from the top of section 9 to the foot of section 13. A train of such polyphasal surfaces may be drawn, as is indicated in the diagram, but the successive members of the series cannot of course be distinguished—like the wave-fronts—at any moment by their relative phase values, for all phases may be found at every instant in every one, excepting only the mutilated members of the series. It is clear that these polyphasal surfaces or fronts will be propagated forward in precisely the same way as if they were wave-fronts. For every point in any one of these slanting surfaces is also a point

upon one of the plane wave-fronts. Now, it is a fundamental assumption upon which the undulatory theory of light rests, that every point upon a wave-front radiates light in all directions, as if it were itself a primary source of light. Therefore, the fact that any such point radiates light along the zero axis is proof that it must also radiate light along the inclined axis now in question. If then we have light coming off from every point of this polyphase surface parallel to an axis, at right angles to the surface itself, we may infer that that light will be propagated undiminished in that direction, for between rays of light that move in parallel paths there can be no interference. We shall therefore have plane polyphase fronts passing the aperture  $A A'$ , just as plane wave-fronts pass the aperture  $A A$ , refracted by similar appliances to the focal point  $F'$ , and producing there upon another index particle a disturbance proportioned to—proportioned to what? Not now proportioned to the area of the polyphasal front that passes the aperture, for the various phases of any given front, when they are made by focussing coincident in space and time, will not reinforce one another. On the contrary, the impulse which started from the point of intersection shown in the diagram with the plane wave-front 12 will be exactly equal and opposite to the impulse which started from the point which the same polyphase front had in common with the wave-front 10. Therefore, these two impulses will cancel one another. It is thus evident that there are ineffective elements in these polyphase fronts, and that their light-yielding power can only be estimated by making the necessary deduction on this account. In the case of the particular series of fronts now in question, it will be at once apparent that the necessary deduction leaves nothing over. For just as the two points 10 and 12 paired off and cancelled one another, every other point will have its pair also. Take for example any point adjacent to 10 and call it  $10a$ . There must be another point similarly situated with regard to 12, which we may call  $12a$ , that will become in the focus the pair and equivalent of  $10a$ , cancelling its effect. Thus the algebraical sum of all the impulses received from any one of these series of polyphase fronts will be  $\Sigma = 0$ , a fact which is indicated on the diagram by showing the convergent beam and focus in full black.

It will be useful to pursue this line of investigation a step farther, but more convenient to use another diagram than to accumulate more details upon fig. 76. Fig. 77 reproduces the essential parts for this purpose of fig. 76 and will be understood without further description.

Here we have to consider first, the polyphasal surface  $\phi_3$  which contains not only one complete set of phases as does  $\phi_2$ , but also one half-set over, that is to say, it contains three half-sets of undulation phases. It is clear, therefore, that as in the case last discussed,



one of these half-sets will cancel the second, and the three half-sets taken together will have no more effective radiating surface than one of them would if it stood alone. Now, any one of them occupies only one-third of the aperture, so that the light which gets through and survives can only be compared with the light given off

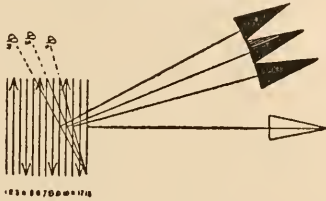

FIG. 77.

from one-third part of the aperture if occupied by an uniphasal front or plane wave-front. This may be expressed by saying that the *aperture value* of the polyphase front  $\phi_3$  is only one-third full aperture value. But to say so would be to exaggerate, for it will be observed that the effective area is not uniphasal. On the contrary, it contains one complete half-set of phases, which are of course to some extent discordant, although not entirely destructive of one another's impulses like the paired points of the two cancelled thirds. The numerical evaluation of the deduction from focal brightness which ought to be made on this account, will not concern us in the present paper. The conclusion necessary for present purposes is sufficiently indicated in the diagram where two-thirds of the convergent beam are shown in full black and the remaining third in subdued white. It is evident that the light-carrying power of this series of polyphase fronts is greatly diminished.

A word will suffice to dispose of  $\phi_4$ . This surface carries four half-sets of undulation phases, and from what has been already said it is plain that they will mutually cancel one another. It therefore focusses in full shadow as shown, a fact which we may express by saying that its aperture value = 0.

In the foregoing diagrams a method of representing the effects of diffraction has been worked out, which will make the following diagram (fig. 78) intelligible without verbal description. Assuming the wave-length indicated in the diagram to represent  $\frac{1}{300000}$  in., the aperture shown would have a diameter of  $\frac{1}{300000}$  in., and the various polyphase fronts  $\phi_1$ ,  $\phi_2$ , &c. would lie at the angles shown. It will be noticed that even with an aperture so small as this the aperture value of the diffracted beams, even of the successive maximum beams, becomes inconsiderably small before the diffraction angle has reached any great magnitude. Thus the maximum

polyphase front  $\phi_3$  which stands at an angle a little less than  $45^\circ$  to the plane wave-fronts, has according to the diagram an aperture value not exceeding  $\frac{1}{80000}$  in., and this value, if allowance be made for the want of unison in its phases, would have to be reduced to little more than one-half this figure.\* Thus the light

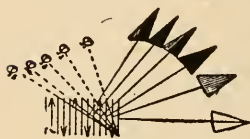

FIG. 78.

diffracted along this axis from this aperture does not exceed in intensity what would be carried by an undiffracted beam through an aperture having a diameter of  $\frac{1}{125000}$  in. It is worth while to make a small digression at this point in order to observe that we could not increase the intensity of the light diffracted along this axis by lengthening the vertical diameter of the aperture. We should thereby increase the number of phases on the polyphase front and the area of the front itself in the same proportion; but as we should reduce its aperture value at least in the same ratio there could be no resulting increase in the intensity of the radiation along this particular axis. In like manner, if we reduced the diameter of the aperture we should not necessarily thereby diminish the amount of the light diffracted along the axis in question. We should diminish the number of phases, but as these cancel one another in pairs the removal of every successive complete set of phases from the radiant surface will cause no change in the illumination at the focal point. This illumination

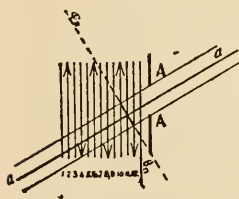

FIG. 79.

can only be affected to the extent to which it may be increased or diminished by the removal of a half-set, quarter-set, three-quarter set or other incomplete set of phases, and the change will be greatest when exactly one half-set of phases is removed. Then the light will fall from maximum to zero, or rise from zero to maximum, or pass from an intermediate degree of intensity to its complementary degree of intensity, as the case may be. But however the aperture value of the aperture may vary it can only vary between the limits of equivalence to one half-set of phases and zero. This fact affords us a simple rule for determining the maximum amount of light that can be radiated by diffraction along any particular axis. Suppose that we cut down the aperture as shown in fig. 79, until the polyphase front  $\phi_n$  crossing the plane wave-front at an angle  $\theta_n$  extends, as shown, exactly from wave-front 10 to wave-front 12. Then the polyphase front will contain one half-set of phases and therefore have a

\* The fraction is exactly  $\frac{2}{\pi}$ .

maximum value. However much the surface be extended it cannot radiate along the axis  $a . . a$  any greater quantity of light than passes through the small aperture  $A . . A$ .

It is evident that this maximum aperture—or rather maximum aperture value—stands in some definite relation to the length of a wave of light, and without elaborating the mathematics of it in this place it will be interesting to note down one or two instances of the maximum amount of visible radiation which can be diffracted off at one or two selected angles from a beam of parallel light. We will assume green light from the most luminous part of the spectrum having the wave-length  $\lambda = \frac{1}{100000}$  in. Then the utmost amount of light that can be so diffracted off from such a beam—whatever its aperture—at  $45^\circ$  would pass through a chink rather less than  $\frac{1}{100000}$  in. in diameter and in length equal to the breadth of the aperture, and even the light so passing would not be uniphasal. The quantity of light which an aperture of this breadth, and of any ordinary dimensions as to length, can transmit, must be quite inconsiderable, and for ordinary purposes not distinguishable from zero or absolute darkness.

Of course an angle of  $45^\circ$  is a large angle: suppose we take a small one, say an angle of  $1^\circ$  equal to (say) a rise of a foot in 20 yards. The maximum aperture value of light diffracted along this axis calculated in the same way will be a little less than  $\frac{1}{100000}$  in. Again, for ordinary purposes we may treat the light that can pass through a chink less than  $\frac{1}{2500}$  in. in breadth as being the equivalent of darkness or full shadow, and we thus see incidentally how it is that the undulatory theory of light explains the propagation of shadows along what are visibly straight lines. But we also see what is even more important for our present purpose, namely, how the amount of light diffracted along any given axis can be increased and rendered visible. To this point we may now proceed.

Suppose that our aperture is a square aperture having a diameter of  $\frac{1}{4}$  in., and that it transmits a beam of parallel light. We know now that the aperture value of that beam of light along an axis inclined only  $1^\circ$  to its own axis will be less than half of  $\frac{1}{10000}$  in. Therefore, leaving out of account a small correction and treating the aperture as equal to its own projection on the polyphase front which is inclined to it, at this small angle of  $1^\circ$ , we may say that this  $\frac{1}{4}$ -in. aperture contains upwards of 500 zones each of which is capable of radiating as much light as the full aperture itself in this direction. Suppose then that we divide up its face into 500 facets each  $\frac{1}{2000}$  in. in breadth. Suppose furthermore that we block up alternate facets, say the facets which contain what at a given instant might be identified as the negative half series of phases. Then the facets that are left will shine without hindrance along our  $1^\circ$  axis, and if we bring their

light to a focus we shall at the focal point have an image of the source of light 250 times as bright as the image which could be obtained in that position from the full aperture. It is not only at this point that the grating brightens up the diffraction pattern of the full aperture. Take, for example, the axis along which each of the open facets would transmit three half-sets of phases, two positive half-sets, say, and one negative. Then the blocked-out facets will suppress the alternate triplets containing each two negative half-sets and one positive. Thus, along this axis the positive half sets will be in the proportion of 2:1 as compared with the negative half-sets, and there being 250 of them added together at the new focal point they will make up a conspicuous image in the shadow of the full aperture.

It is, however, to be noted that the increase of light within the geometrical shadow of the aperture is paid for by a diminution of light within its optical projection. For the blocking-out of half the facets formed upon the face of the aperture will have *pro tanto* diminished the directly transmitted light and so reduced the brightness at the geometrical focus by one-half. In like manner the diffracted beams, which being diffracted at very small angles come to focus very near to the geometrical focus, will suffer each in its own proportion; in fact every beam which has a maximum aperture value greater than the diameter of the full aperture will be reduced in brightness by the placing of a diffraction grating across it. The other beams, having a less aperture value than this, will be brightened or darkened or left unaffected as the case may be, according to the numerical relation between their aperture values and the aperture values of the transparent zones in the grating.

This, in outline, is the theory of diffraction and the diffraction grating. I have troubled you with it thus at length because it is of essential importance that it should be in your minds when you proceed to the discussion of the Helmholtz theory. But it will, of course, be understood that Helmholtz himself does not develop the theory of diffraction in his paper. On the contrary, he takes it all for granted, and writes as abstrusely about it as the most hardened mathematician. He does not even pause to prove that polyphase fronts, as we have seen, are propagated, refracted, focussed, and reflected precisely like wave-fronts. These things are clear enough to the mathematician who is certain that a particular formula accurately expresses a particular phenomenon. But to readers with more turn for the physics than for the mathematics of the explanation, the proof is grateful or even necessary.

So far we have considered only the law of diffraction from plane wave-fronts, but in the Microscope and all other image-producing instruments we have to deal with spherical wave-fronts, and the law of diffraction as applied to them becomes of paramount

importance. This problem Helmholtz attacks, and his solution of it constitutes, as I venture to think, the real merit and the very great merit of his paper. Yet the law disclosed by him appears to be still unknown to those whose business it is to explain these things, and you will look in vain in the text-books for any exposition of the fundamentally important propositions in which he embodies it. Of the practical importance of the conclusions which Helmholtz reached you will this evening have the opportunity of judging for yourselves.

In order to lay the foundation for his theory, Helmholtz commences by giving two proofs of what is now known in optics as "the sine condition." He first formulates it thus, subsequently modifying the formula by substituting the sine of the divergence angle for the divergence angle itself. As it stands here the proposition is due to Lagrange; as modified by substituting the sine for the angle it is due to Helmholtz.\*

"The product of the divergence angle of a given ray, the

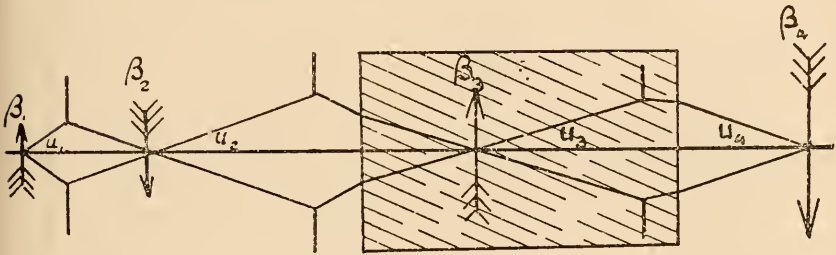

FIG. 80.

refractive index of the medium in which it lies and the magnitude of the image formed in that medium in which it comes to focus remains constant in a centred system of spherical refracting or reflecting surfaces after any number of refractions or reflections, provided that the conditions of correct image-formation are satisfied."

"It follows that this function has the same value when the ray has left the system as before its entry into the system."

This is rather a formidable enunciation of a law which may be very simply expressed in symbols and easily understood by the aid of the diagram fig. 80.

Here we have four successive images formed one from another

\* It is said that Prof. Abbe announced the sine law—withholding the proof of it—some few weeks before the appearance of Helmholtz' paper. I have no personal knowledge of this, having sought in vain for the announcement, and mention the claim only lest it should be thought—as has indeed been suggested by some of Prof. Abbe's friends—that I am doing an injustice to the Professor by not importing the discussion of this matter into the present paper.

the first, second and fourth in air, the third in glass. If we write  $\beta_1 \beta_2 \beta_3$  and  $\beta_4$  for the diameters of the several images,  $u_1 u_2 u_3$ , and  $u_4$  for the divergence angles of the image-forming beams, and  $n_1 n_2 n_3$  and  $n_4$  for the refractive indices of the media in which they are severally formed, we may write Helmholtz' proposition symbolically thus :

$$\begin{aligned} n_1 \sin u_1 \beta_1 &= n_2 \sin u_2 \beta_2 = n_3 \sin u_3 \beta_3 \\ &= n_4 \sin u_4 \beta_4 = \&c. \text{ ad infinitum.} \end{aligned}$$

It will of course be understood that the divergence angle  $u$  is the angle formed with the optical axis by the ray which touches the edge of the aperture.

Of this proposition Helmholtz gives, as I have said, two proofs. The first is borrowed from and credited to Lagrange. Helmholtz accompanies his reproduction of it with a criticism pointing out that

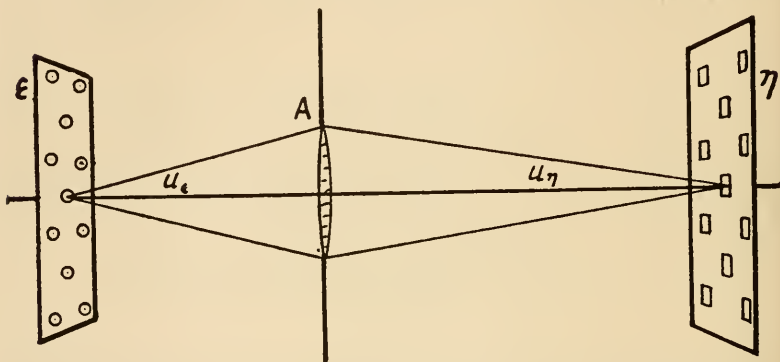

FIG. 81.

it is imperfect, inasmuch as it applies only to divergence angles\* of infinitesimally small magnitudes.

Helmholtz therefore, with handsome acknowledgments to Lagrange, propounds a new and very elegant proof of his own.

Divested of its mathematical expression and thrown into the form of an imaginary experiment, Helmholtz' proof may be explained as follows.

Let  $\epsilon$  in the diagram (fig. 81) be a board on which are mounted a number—any number—of electric lamps arranged in squares, quincunx, or otherwise, so as to secure their even distribution over the surface of the board. At A let there be a circular aperture filled by a lens, and let  $\eta$  be another board fitted with a number of

\* In the unrevised proof which was circulated before the meeting on the 18th March I inadvertently wrote "images" for "divergence angles" in this place.

mirrors so disposed that a mirror receives and throws back through the aperture the light transmitted by the aperture from every one of the lamps. Then the mirror-board will be the perfect and radiant image of the lamp-board.

It is plain that the amount of light received by each mirror will be conditioned by two things: (1) the brightness of its lamp; and (2) the size of the aperture.

Assume that all the lamps burn with the same brightness, and let this factor be denoted by  $J$ . Then  $J \times$  area of the aperture will give us the measure that we want of the light radiated in unit time by any one lamp to its mirror, and back by the mirror to its lamp.

If now the refractive system yields a perfectly correct image in the mirror board  $\eta$  of the lamp-board  $\epsilon$ , every lamp must send this same quantity of light\* to its mirror, and every mirror must stand at a distance on the mirror-board from the central mirror, proportionate to the distance of its conjugate lamp from the central lamp. Thus, the lamps being by hypothesis equidistant from one another, the mirrors must be equidistant also, and the common distance of the mirrors from one another will have the same proportion to the common distance of the lamps apart that the diameter of the mirror-board has to the diameter of the lamp-board. It will simplify description if we assume that the lamp-board is entirely filled with lamps that fit close to one another like cells in a honeycomb, and that the mirror-board is similarly filled with mirrors receiving and reflecting each the light of a single lamp. Then we shall know the relative dimensions of the object  $\epsilon$  and of its image  $\eta$  if we can ascertain the relative sizes of one of the lamps and one of the mirrors.

The determination of this proportion will become very simple if we replace the mirror by a lamp which shall be exactly equivalent to it in the power of radiating light through the aperture, for then we shall have a source of light that can be directly compared with the original source of light on the lamp-board. Let it be assumed, then, that the central mirror on the mirror-board is replaced by a lamp so selected, that, seen from the aperture, the lamp shall be indistinguishable from the mirror. It must then burn at the same temperature as the other lamps reflected in the neighbouring mirrors, or it would be distinguishable from them by superior—or as the case might be by inferior—brightness. It must be of the same size as the apparent size of the reflected lamps or it would not fit into its own place. But

\* Strictly speaking this is, of course, an impossible condition because the angular value of the aperture falls off as the radiant point departs from the axis. All actual apertures are, therefore, to some extent astigmatic, but in small fields—such as those of the Microscope—this is of no practical importance, and we may fairly assume the theoretical condition to be satisfied.

these requirements satisfied, it is obvious that the new lamp will fulfil the condition of radiating through the given aperture the required quantity of light in unit time.

But, unlike the mirror, the lamp will radiate light not only through the aperture but also in every other direction, and the radiation which passes the aperture will be only a fraction of its whole output. If we calculate its whole output of light and compare it with the whole output of its object lamp, we shall have the means of determining their relative radiating surfaces, for we know that both are burning at the same temperature, and therefore giving off the same amount of light in unit time from unit

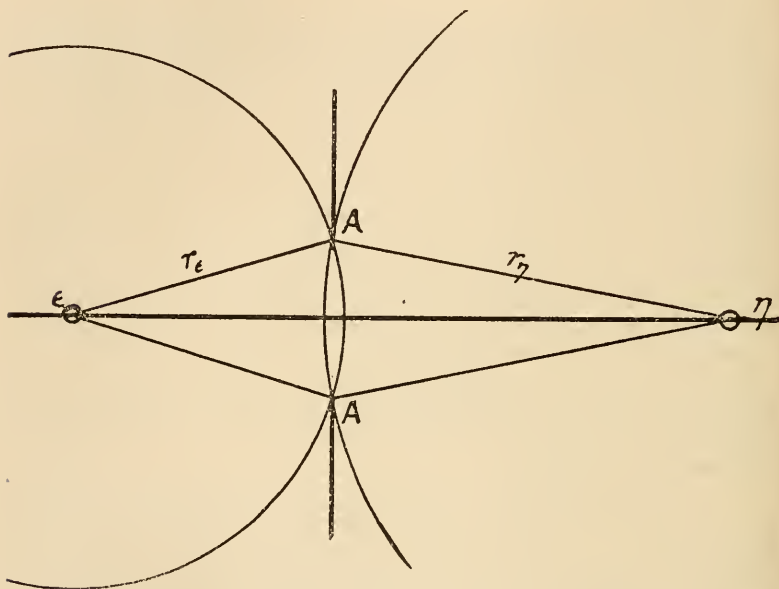

FIG. 82.

surface. This comparison will be facilitated by the diagram fig. 82 in which the two lamps are represented by two very small radiant globes lying on the optical axis, and the aperture is represented by the circle in which two spheres intersect that are described round the two lamps respectively.

Now, it is clear that the new lamp  $\eta$ , if it is to send through the aperture  $AA$  as much light as the old lamp  $\epsilon$  sends, must produce more total light, for it wastes a larger proportion of what it produces, and this waste is represented by the whole remaining area of the sphere having a radius  $r_\eta$  after allowing for the aperture, whereas the lamp  $\epsilon$  only wastes the smaller quantity represented by the surplus of the smaller sphere upon the radius



$r_\epsilon$ . The total light produced by  $\eta$  in unit time must therefore stand to the total light similarly produced by  $\epsilon$  in the ratio  $\frac{r_\eta^2}{r_\epsilon^2}$ .

From this we infer at once that the radiating surfaces of the two lamps must bear the same proportion to one another, and if the lamps be, as here shown, radiant spheres, their diameters will be as  $r_\epsilon : r_\eta$  simply. We may therefore write

$$\frac{r_\eta}{r_\epsilon} = M, \quad . \quad . \quad . \quad . \quad . \quad (1)$$

the magnifying power of this system, since we have already seen that the proportion is the same in fig. 81 between the lamp-board and its image as between these conjugate lamps.

We have tacitly assumed in this demonstration that both lamps are burning in the same luminiferous medium. This is of course no longer necessarily the case when we substitute focussed images for lamps, since a focussed image may be formed in any transparent medium. We must then consider what difference it would make to the foregoing proof if we were to assume a more sluggish medium behind the aperture than in front of it, say glass with a refractive index of 1.5 behind and air in front.

The problem so presented is not a difficult problem except in the sense that it is usually discussed with the most unpleasant array of mathematical symbols. Helmholtz does not himself discuss it, but assumes the result reached by Kirchhoff, and more commonly connected with the name of Clausius.\* It is very easily investigated by the help of analogies, of which many familiar examples present themselves to the mind. Perhaps nothing can be more familiar than the common eight-day clock—not a superior article provided with dead-beat escapement, but one in which there is a strong reaction between the scape wheel and the pallets. There we have an example of energy consumed in producing oscillatory movements, and it is familiar knowledge that the capacity of the weight to impart energy to the pendulum, depends in part upon the mass of the weight, and in part also on the mobility of the pendulum. Increase the weight and you will quicken the beat of the clock, although the clock-maker has done his ineffectual best to make the period of the pendulum independent of the driving power. Shorten the pendulum, so rendering it more mobile, and you may, if you shorten it enough, enable the driving power to discharge its eight days' supply of energy through that very active pendulum in eight minutes.

\* Helmholtz quotes Kirchhoff probably from memory, certainly without giving any reference to his paper. But it may almost certainly be identified with the paper on the relation between the power of bodies to emit and to absorb heat and light, which appears in Pogg. Anu., cix. (1860) p. 275. For Clausius' exposition of the law, see his *Mechanische Wärmttheorie*, 8th Memoir, or in English, Hirst's translation of Clausius on Heat, p. 290.

The same thing holds in all cases of the development of energy in the form of oscillation. A mobile medium will take more energy from a given source of power in a given time than a sluggish medium and more energy can be imparted to a sluggish medium from a high potential source of power than from one of low potential. Hence we should expect that if a focus of light-discharging energy is found to maintain a certain rate of output in a sluggish medium, it will necessarily discharge from a higher potential, than if it were discharging at the same rate in a more mobile medium.

Bearing this principle in mind, we may take up again the problem of the focus formed in glass. It will be simplest to imagine this as a minute sphere radiating light in every direction. Suppose that it radiates for some small unit of time—a 650th part of a millionth of a second for example—during which time it will have filled a sphere 2 feet in diameter; and imagine further, that



FIG. 83.

at that radius the glass medium is bounded and that the expanding wave-fronts pass without refraction into a vacuum. When the foremost wave-front reaches this boundary surface, let the glow be extinguished. Then  $\frac{1}{650 \times 10^6}$  of a second later all the light will have escaped from the glass globe and will be occupying a spherical shell around it, as is indicated in fig. 83.

Furthermore let it be assumed that at the surface which the foremost wave-front has now reached, there is a spherical mirror with internal reflecting surface on which the centrifugal light impinges and by which it is reflected back. Lastly, assume that somewhere in the shell of the mirror there is a hole through which we can look in and examine its interior.

If now there were no dissipation of light in other forms of energy the wave-fronts set up in this enclosed space by that momentary glow would go on rebounding from the surface and crossing the centre indefinitely and finally we should have two sets of standing wave-fronts established as in a Lippmann film. The one set would cling to the surface of the mirror, and the other set would cluster about the centre. These being stationary and permanent could be seen, and it would soon occur to an observer that every one of these standing wave-fronts was an image of the illuminated part of the mirror. Opposite the hole in the mirror would be a dark image of the hole on the opposite side of the mirror, and there would be two corresponding dark spots in all

the standing wave-fronts, correctly imaging in shape and dimensions those two gaps in the surface of the mirror. The images which would be found clinging round the inner surface of the mirror need not detain our attention, but it concerns us to note that the glass globe is exactly half filled with the central images, of which the largest therefore is 6 in. in diameter, and the rest are gradually smaller in size, having intervals of half a wave-length between them. Fig. 83 illustrates this state of things.

Next suppose the glass globe to be taken out, but the apparatus to be used otherwise in the same way as before. We shall now have the same number of images as in the first case, and they will be arranged on the same plan, that is to say, with one set clinging to the surface of the mirror, and the other set clustered at the centre. The set clinging to the mirror is exactly the same as before, but the set clustered at the centre is now a set of larger images than the first. For every one encloses the next inner one at a distance of half a wave-length in vacuo and, therefore, the largest is now not 6 in. in diameter, but  $6 \times 1.5 = 9$  in. Similarly with all the rest. Every image of the series is larger than the corresponding member of the series formed in glass in the ratio  $n = 1.5$  in this case.

These images have been formed in a very special way, and it is perhaps not obvious that the same law of relative magnitudes would apply to images not of an aperture, but formed *by* an aperture of an object lying outside it. It should then be observed that these standing wave-fronts, although manifestly images of the mirror, are images of the focus also, and really formed by the ordinary and *only* method of image-formation, that is to say, by the interference of crossing and coincident wave-fronts. The distances at which repetitions of these interference phenomena can occur depend manifestly on the wave-length in the medium in which they occur, and if the distance apart of successive images is proportional to the wave-length, the magnitude of the smallest and of every image in the series must be proportional to the same magnitude, for the radius of the smallest and of every other image, is only its distance from the zero point of the scale. It follows that the law which determines the relative magnitudes of these images must equally apply to all images which are formed by the interference of wave-fronts by regular projection through an optical

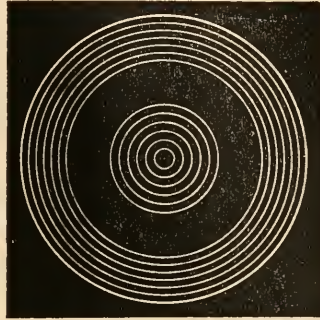

FIG. 84.

centre. The law therefore derived from this example is perfectly general, and if  $\beta_v$  be the diameter of an image formed in a vacuum and  $\beta_g$  be the diameter of the corresponding image formed in glass, we shall have the numerical relation between them expressed by the equation

$$\frac{\beta_v}{\beta_g} = n_g. \quad . \quad . \quad . \quad (2)$$

Recurring now to equation (1) above (p. 393) we may give to it a more general form. As it stands it applies only to the case in which both the conjugate images are formed in the same medium. If we now consider the general case in which in front of the aperture we have a medium in which the wave-length is  $\lambda_\epsilon$  and behind it one in which it is  $\lambda_\eta$  we shall have for the magnifying power.

$$M = \frac{\lambda_\eta r_\eta}{\lambda_\epsilon r_\epsilon} \quad . \quad . \quad . \quad (3)$$

This is Helmholtz' first result, but he expresses it somewhat differently. For the purpose that he has in view it is convenient to express the magnitude  $r$  in terms of the divergence angle  $u$ . A glance at fig. 82 (p. 392) will show that  $r = \frac{A \dots A}{2} \times \frac{1}{\sin u}$ . Therefore equation 3 may be written

$$M = \frac{\beta_\eta}{\beta_\epsilon} = \frac{\lambda_\eta \sin u_\epsilon}{\lambda_\epsilon \sin u_\eta} = \frac{n_\epsilon \sin u_\epsilon}{n_\eta \sin u_\eta} \\ \therefore n_\epsilon \sin u_\epsilon \beta_\epsilon = n_\eta \sin u_\eta \beta_\eta. \quad . \quad . \quad (4)$$

which is the form that the equation takes in Helmholtz' paper. In this expression  $n_\epsilon \sin u_\epsilon$  is what is now known as the numerical aperture of the objective, and  $n_\eta \sin u_\eta$  the numerical aperture of the image formed in the instrument, or as the case may be, in the observer's eye.

It would probably simplify the understanding of the significance of numerical aperture by microscopists who do not happen to be also mathematicians if they were told that the sine relation or numerical aperture law amounts only to the very familiar proposition that the magnifying power of a lens varies inversely as its

\* This expression is a little more symmetrical than the equivalent expression

$$M = \frac{n_\epsilon r_\eta}{n_\eta r_\epsilon}$$

focal length—subject to two provisos: (1) That focal lengths shall be measured in time, that is to say, taken to be proportional to the optical path; and (2) That if the image be formed in a medium where the wave-length is short its diameter is to be shortened in the same proportion as the wave-length.

Having obtained this equation (4), Helmholtz proceeds to apply it in various ways to the examination of the Microscope. And first he proposes by its aid a system of rating objectives by what he calls Normal Magnifying Power. Normal magnifying power, for which Helmholtz proposes the symbol  $N_0$ —may I presume to suggest  $M_0$ —may be explained thus:—

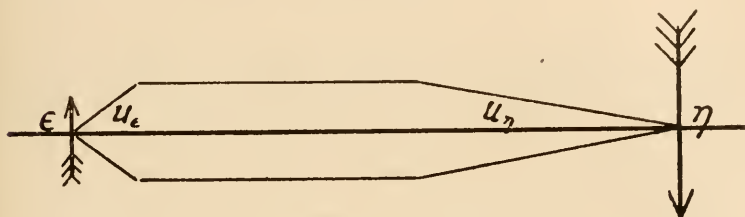

FIG. 85.

Let  $u_ε$  be the divergence angle of the wave-front which enters the objective from the stage of the Microscope, and  $u_η$  be the divergence angle of that which focusses in the observer's eye. Then  $\frac{\beta_η}{\beta_ε} = \frac{n_ε \sin u_ε}{n_η \sin u_η} = M$ , the magnifying power of the instrument. In place of the actual eye Helmholtz proposes a conventional eye, to be taken as a standard of comparison. This conventional eye would have a pupil 3 mm. in diameter and a focal length, in air, and measured of course from the edge of the pupil, of 250 mm.; therefore its N.A. is  $\frac{1.5}{250} = 0.006$ . It will of course be recognised that this is not even an approximation to the numerical aperture of the actual human eye, which has a focal length of less than one inch, and focusses in a medium having about the refractive index of water. But any standard, if adopted, would serve almost as well as any other for the making of comparisons between different objectives, and on Helmholtz' plan an objective of N.A. = 0.006 would have a normal magnifying power  $M_0 = 1$ . Accordingly a lens with N.A. = 1 will have a N.M.P. =  $\frac{1}{0.006} = 166.7$ , and so on.

In a simple Microscope, say, for example, a pair of spectacles, the N.A. of the lens must be obtained by dividing 1.5 mm., the semi-diameter of the pupil of the eye, by the focal length of the lens,

for between the diameter of the lens and its N.A. in use there is, generally speaking, no relation whatever. Fig. 86 illustrates this point.

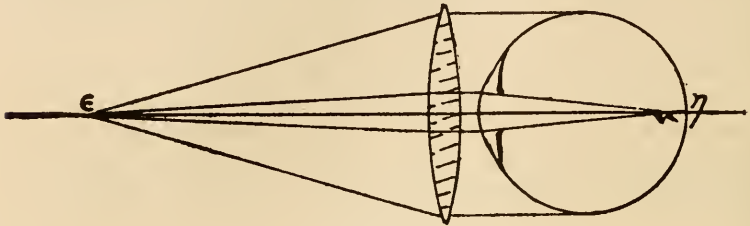

FIG. 86.

Here the limiting aperture of the system is the diameter of the iris, and it is the function of the glass to deliver a beam of plane wave-fronts, i.e. a parallel beam of light, to the eye. Absolutely parallel it need not be, for the eye has a certain power of accommodation enabling it to supplement the work of the Microscope—or other lens—to a small extent. But it is just because the incident beam is divergent beyond the power of easy accommodation that recourse is had to the use of spectacles.

Let it be next supposed that in place of a pair of spectacles used to look directly at the ultimate object we have the eye-lens of a Microscope, and view through it the image formed by an objective in the image plane of the instrument. Then we have a compound Microscope, and the magnifying power no longer depends upon the focal length of the eye-lens or upon its N.A. as determined by the aperture of the pupil, but upon this multiplied by the magnifying power of the objective which produces the enlarged image in the image-plane of the instrument. It may seem at first sight as if this were in no way limited by the diameter of the pupil, but the following diagram makes it plain that the limitation still holds.

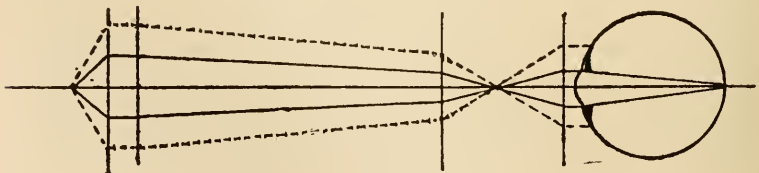

FIG. 87.

It will appear from this without discussion that the optical projection of the iris upon the principal plane of the objective is the effective working aperture of the instrument, whatever may be the aperture with which it is credited in the maker's catalogue,

and that all that marginal angle which sheds light outside the aperture of the eye is at best only so much lost opportunity in the use of the instrument.

*Brightness of the Image.*

It is in this connection that Helmholtz makes his first point of practical importance. He points out that all this lost light contributes nothing to the brightness of the image seen in the instrument. It is therefore possible to use an eye-piece of higher power without diminishing the apparent brightness of the image until a magnifying power is reached equal to the N.M.P. of the instrument. Fig. 88 illustrates this point. Here we have a given objective backed by three different eye-pieces, called No. 1, No. 2, and No. 3 respectively. No. 1 has a low magnifying power, proportional to the focal length  $r_1$ , and gives an emergent beam larger than the

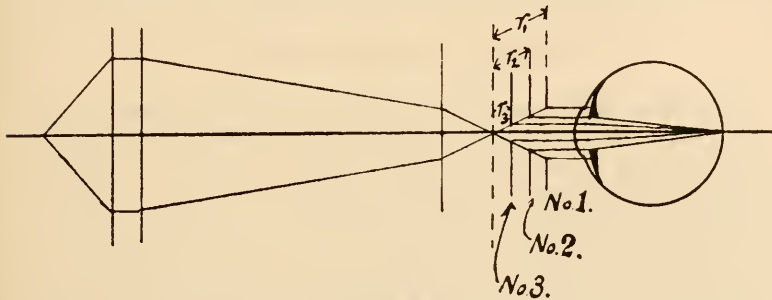

FIG. 88.

pupil of the eye. The excess is simply thrown away, and in the eye we have an image conditioned, as to scale, by the low angle subtended by the semi-diameter of the pupil and, as to brightness, by the area of that part of the beam which passes into the eye. Eye-piece No. 2 yields a better result. Its magnifying power is greater in the proportion  $\frac{r_1}{r_2}$ , and the eye gets the benefit of its full N.A. But its image, although larger than that produced by No. 1, is just as bright, for it sends a beam of superior brightness into the eye, since its beam conveys all the light coming through the optical centre into the eye, and the light thrown away by objective No. 1, but utilised by No. 2, is manifestly exactly proportioned to the increased scale of the image. Thus the larger image is equally bright—a clear gain.

The eye-piece No. 3 has still higher magnifying power in the proportion  $\frac{r_2}{r_3}$ , but its use cuts down the aperture of the eye itself

as is obvious from the diagram. It throws into the eye the same quantity of light only as eye-piece No. 2, and as it produces a larger image, the brightness of that image must suffer in proportion.

We now see that N.M.P. represents a definite limit in the capabilities of an objective. For magnifications less than  $M_0$  the lens gives images of full brightness. But beyond this point the brightness of the magnified image begins to fall off. The total light is still the same in amount, but the light collected on a given point of the super-amplified image is only a fraction of that which comes from its object-point. And the fraction rapidly comes to be a very small one. The diagram shows that it is proportioned as area of pupil to area of emergent beam, that is to say, as  $\left(\frac{M_s}{M_0}\right)^2$  if  $M_s$  be written for the degree of magnification of the super-amplified image. In this sense, therefore, N.M.P. is the point at which the image begins to deteriorate.

#### *Entoptic and Ocular Shadows.*

The next point is again a matter of practical importance connected with this diminution in diameter of the beam received by the eye which accompanies high magnifying power. Helmholtz points out that when these beams become very narrow, we have precisely the conditions which cause shadows of objects within the eye to be thrown with sharp definition upon the retina and so to blend with and impair the visible image. This is explained by Helmholtz in a passage which I will take the liberty of quoting textually. After describing the Ramsden circle of the Microscope, (see fig. 89 below), he says:—

“Here, however, we meet with other difficulties arising from the *very small divergence angle of the emergent beam*, as is shown in the case of great amplification by equation (12).\*

“First there are the shadows in the eye, of entoptic objects which crowd more and more into the field of view in proportion as the above-mentioned ocular image of the objective becomes smaller. This image is the source of illumination to the retina; all the light which enters the eye comes from it. It is at the same time the base of the complete beam containing all the pencils of light which connect the several points of the object with their retinal images, and its diameter diminishes as is above shown, for high magnifications, in proportion as the magnification increases. But the known condition which must be fulfilled in order to produce strong sharp shadows of entoptic objects is precisely this, that the intromitted light should reach the eye from a very small surface. Anyone

\* Equation (4) above.



who has ever attempted to brighten up the field of a Microscope under excessive magnifications by recourse to sunlight will know the peculiarly spotty appearance of the field which is so produced. Some of the spots remain fast in the field of the instrument, others move about with the eye. The first-mentioned take their rise in spots and imperfections of polish upon the ocular, the last in the cornea, lens and vitreous humour of the eye. This treatment has long been known as a method of seeing entoptic objects and is in fact very useful. But upon the whole, as the entoptic objects become more visible, the delicate microscopic details become more indistinct."

*Diffraction Phenomena.*

A third point of practical consequence is that these very narrow parallel beams give rise to strong diffraction phenomena, thereby causing the light of one point to spread over the image of another, impairing its definition. This is, in Helmholtz' view,

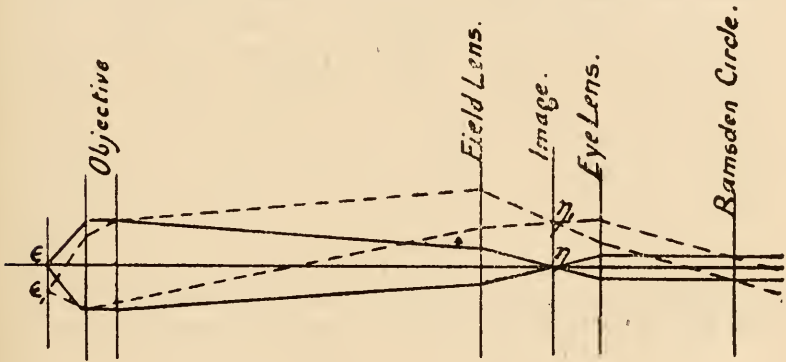

FIG. 89.

the most important cause of faulty resolution in the Microscope. His language is, "There is, in fact, a cause operative in the compound Microscope which, under the given conditions, occasions much more pronounced aberrations of the rays from their foci than chromatic and spherical aberration cause and which is most influential when the beam is narrow angled. That cause is the diffraction of light." Accordingly, his paper, although it treats incidentally of these other matters, is directed, as to its main object, to an inquiry into the effects which are traceable to this cause. Helmholtz prefaces his formal statement of the law by a description of what is known as the Ramsden circle, and as this is now a familiar object to microscopists, it may be sufficient here to refer to this part of his paper in a very few words.

The preceding figure (89) shows diagrammatically the course of two beams—one axial and the other oblique—through a compound Microscope. Both, after focussing in the image plane, spread out in divergent beams and fall upon the eye-lens by which they are brought into the condition of parallel beams of light fit to convey to the eye a picture of the object on the stage. In the plane behind the eye-lens which coincides with its principal focal plane, these beams of parallel light from the instrumental image blend with one another, and all such beams from all points of the image plane here pass through the optical projection of the axial beam. They thus form a very brightly illuminated field which is, in fact, a focussed image of the principal plane of the objective, and can be seen as an external object by drawing the head back to a suitable distance behind the instrument and looking along its optical axis. In like manner it can be seen by a magnifying lens and measured by a micrometer, or a dynamometer, as the astronomers call a micrometer adapted to this purpose.\*

Now, Helmholtz' solution of the problem of diffraction in the Microscope is this. Treat the Ramsden circle as if it were a hole in a card or diaphragm and the image in the focal plane of the instrument as if it were an object of the same size as the image situated in the focal plane of the instrument. Then the loss of resolution due to diffraction will be exactly the same as if that supposed object were actually viewed through that supposed aperture. You will, I imagine, agree that this is a most charmingly simple solution of a most formidable problem and that the proof of it must be worth following up even at some cost of mental labour. But in truth the mental labour involved is not serious, so elegant is the proof, and when I took the liberty in the opening part of this paper of summarising the theory of diffraction, I dealt with what is by far the most difficult part of the whole inquiry.

#### *The Proof of Helmholtz' Proposition.*

Coming now to the proof of this proposition. It is at once obvious that diffraction to this extent at least must be a disturbing influence in the final image which is pictured upon the retina. For these beams of light must give off diffracted beams and the diffracted light so given off must enter the eye and be focussed by it in the same way as the principal beams themselves. To this extent, therefore, the proposition must be true and the object seen must be at least as badly resolved as if it were viewed through a narrow aperture having the diameter of the Ramsden circle. The

\* On this point see Mr. Nelson's paper in the *Journal Royal Microscopical Society* vol. for 1901, p. 242.

question really is, Will it not be more impaired by diffraction? What about diffraction that starts in the objective? What about diffraction that starts from the stage itself? What about diffraction that starts from various points along the beam in its course from the source of light to the observer's retina?

It will strike you probably that to a certain extent these questions answer one another and themselves. Take the last for example and in a simplified form put it with reference to a converging beam of light which focusses to a point as shown in fig. 90. Observation shows that we obtain visibly the same dif-

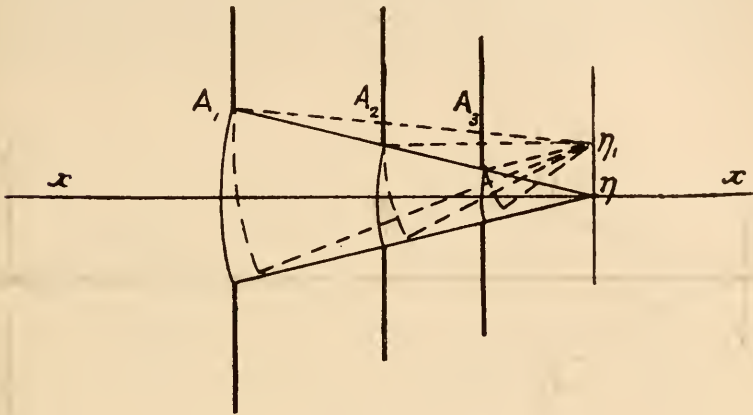

FIG. 90.

fraction pattern whether we limit the beam by the large aperture  $A_1$ , or by the smaller aperture  $A_2$ , or by the still lesser  $A_3$ , provided the one is the optical projection of the others along the course of the beam. The distance from  $\eta$  to  $\eta_1$  is the same however far away the diaphragm may be, provided it always subtends the same angle at the focal point  $\eta$ .

The geometry of this relation is somewhat intricate and involves too much elaboration to be developed here. Helmholtz turns the difficulty very neatly by tracing the course of a diffracted beam through an optical instrument. The following diagram (fig. 91) will illustrate his argument.

Assume an object point at  $\epsilon$  radiating light through the aperture  $A \dots A$ , which light is focussed by the refracting system  $B$  at  $\eta$ . No assumption need be made about this refracting system except that it is aplanatic and produces in the image plane  $\eta \dots \eta_1$  a correct image of the object in the object plane  $\epsilon \dots \epsilon_1$ . Then, in the aperture a diffracted beam will take its rise, which, being refracted as an oblique pencil, will be brought to focus at, let us

say, the point  $\eta_1$ . That being the position of affairs, assume now that the glow at  $\epsilon$  is extinguished and that the point  $\eta$  begins to glow in its turn, under the following conditions. It is to give out light exactly like that which it received, that is to say, identical in colour, attuned in phase and proportioned in intensity, so that the emitted light would upon the surface of the point  $\eta$ , and, therefore, at every surface along the optical system, balance and neutralise the light received from  $\epsilon$ . I will, with your permission, call this supposed beam of light which thus reacts to and cancels the original—I will call it the *reverted beam*. It is not a reflected beam because the individual rays are supposed to travel back along the same paths by which they came, not along paths inclined to the optical axis at equal and opposite angles, and the several wave-fronts do not carry on the original order of phases, they reverse it,

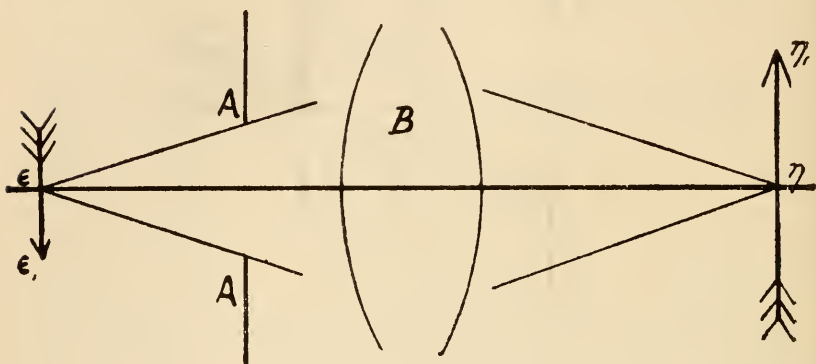

FIG. 91.

and therefore they cancel the arriving wave-fronts at all points of the path and not only at periodic distances of half a wave-length.

Consider now what will happen when the reverted beam re-enters the aperture. There being no radiation from the whilom object-point  $\epsilon$  to quench the reverted beam, it will fill the aperture and the region round about it with wave-fronts exactly like the original wave-fronts in intensity, phase, frequency and form, but travelling in the opposite direction. These wave-fronts will, of course, give rise to diffracted wave-fronts at the aperture; and although the diffracted beams of light will now be propagated towards the object plane instead of being propagated away from it, we can estimate their direction and magnitude by the aid of the original observation. For the diffraction in this case must be equal and opposite to the original diffraction.

Let us then take the point  $\eta_1$  as an example and assume the diffracted beam which focusses there to be reverted through the instrument. Upon its arrival at the aperture  $A \dots A$  it will reinforce and exactly double the diffracted beam, which starts at that aperture from the principal reverted beam, and, therefore, we can ascertain the position of the diffracted image  $\epsilon_1$  by working back to the point in the object-plane which is conjugate to the point  $\eta_1$  in the image-plane.

So far we have assumed an arbitrary position for the point  $\eta_1$  in the image-plane, but with the help of this result we can proceed to determine it by calculation. For, if it is the image of the point  $\epsilon_1$ , its position is determined thereby. Now, the position of  $\epsilon_1$  is

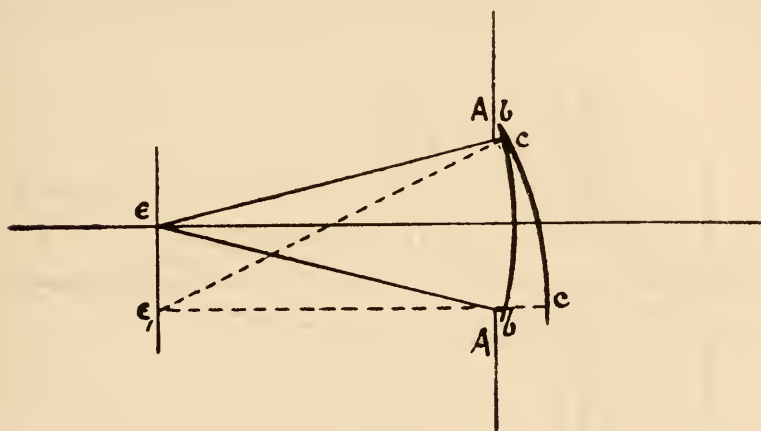

FIG. 92.

evidently determinable without any reference to the refracting system B, for all the conditions upon which it depends are ascertainable the instant that the aperture is passed by the outgoing beam of light from  $\epsilon$ . Suppose then that instead of the refracting system B and the image-plane  $\eta \dots \eta_1$  we make use behind the aperture of a spherical mirror  $b$ , as shown in fig. 92, having its centre of curvature at  $e$ . Such a mirror will reflect the principal beam to  $\epsilon$ , and the diffracted beam not quite accurately to  $\epsilon_1$ . If we assume that for the first purpose it is to take the form of  $b$  symmetrical with reference to the optical axis of the principal beam, and for the second purpose the form of  $c$  symmetrical to the axis of the diffracted beam, we shall have the position of  $\epsilon_1$  perfectly defined. Then the point  $\eta_1$  must be conjugate to this point in the optical system represented in fig. 91.

*The Law of Diffraction for Focussed Light.*

We thus see that the course of diffracted light through an optical instrument can be traced and the focal points of diffracted beams can be found without any detailed consideration of the refractive systems employed and so we can arrive at the important generalisation that the diffraction pattern produced by any given aperture in the focal plane of a lens or system of lenses is simply the focussed image of the diffraction pattern which without that lens the same aperture would throw upon the same plane. We thus arrive at the enormous simplification of being able to make all our calculations relating to diffraction in the open air.

It will be evident that the foregoing proof does not depend

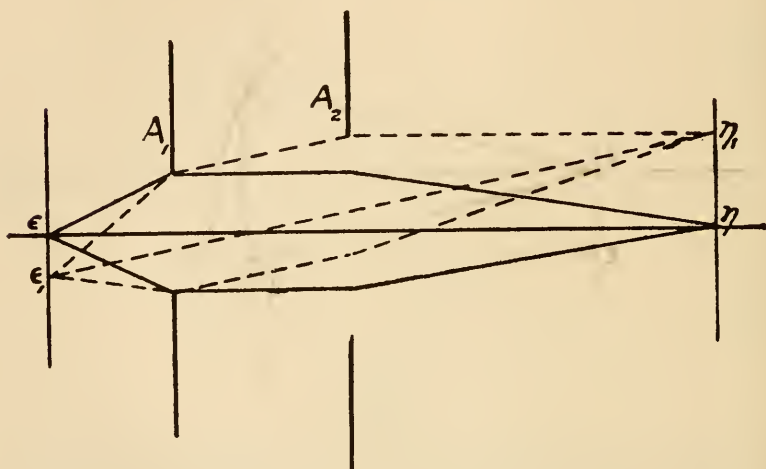

Fig. 93.

upon the assumption of any particular magnitude for the divergence angle at the point  $\epsilon$ . If instead of the diverging beam which passes the aperture  $A \dots A$  (fig. 91) we had assumed a beam of parallel light coming from infinite distance, and the focal plane  $\eta \dots \eta_1$  to be the principal focal plane of the system, the proof would have been just the same. Take then the following case, illustrated by fig. 93. Here  $\epsilon$  lies in the principal focal plane of a lens filling the aperture  $A_1$  and  $\eta$  lies in the principal focal plane of another lens filling the aperture  $A_2$ . They are therefore conjugate points and images one of the other, and the beam which passes between them passes from  $A_1$  to  $A_2$  in the form of plane wave-fronts or parallel rays. In this region between the two

apertures, therefore, its diffraction can be calculated by the known rule for the diffraction of light from plane wave-fronts, and *if the entire beam is transmitted both backward and forward* the diffraction pattern in each of the focal planes will be that produced by focussing these beams of unfocussed light. At last, therefore, the whole problem has been reduced to the problem already solved of the diffraction caused by cutting down a beam of parallel light.

We can, moreover, by the same considerations determine the question of the dimensions of the diffraction pattern produced by the diffraction of light from spherical wave-fronts. For it can be shown—see fig. 94—that the axis of a diffracted beam containing only parallel rays would cut a plane perpendicular to the optical axis of the instrument at a distance from the axis proportional to the distance of that plane from the aperture, and determined by the equation  $\eta = \tan \theta r_\eta$ ;  $\epsilon = \tan \theta r_\epsilon$ . If now these oblique rays are brought to focus by a refracting system capable of yielding flat fields in the conjugate planes  $\epsilon \dots \epsilon_1$  and  $\eta \dots \eta_1$  respectively, these oblique parallel rays must be brought to focus at distances such that  $\eta = \sin \theta r_\eta$  and  $\epsilon = \sin \theta r_\epsilon$ , for this is the condition of correct image formation in these focal planes.\*

This again is a result of capital importance, which, however, is not very clearly brought out by Prof. Helmholtz. Throughout the paper he speaks of diffraction fringes, a term appropriate enough to describe the coloured margins formed by diffracted light about the edges of shadows and beams of unfocussed light, but little enough suggestive of the “false disc” formed by a perfectly corrected lens as the image of a luminous point. When in June of 1901 I had the honour of laying before this Society some criticisms of the Abbe theory, I ventured to define an antipoint as the correctly focussed image of a luminous point, and that definition has been, as I gather, very generally accepted. May I now presume to define it a little more closely, and to point out to you that the correctly focussed image of a luminous point is an image of a certain diffraction fringe, which may easily be defined, but cannot usually be seen. Let the following diagram (fig. 94) serve to illustrate this connection.

A beam of parallel light passes the aperture, say, from right to left, is received on a screen placed at  $\epsilon \dots \epsilon_1$ , and thereon projects a shadow image of the aperture, the central ray passing through the point  $\epsilon$ . A diffracted beam is thrown off at an angle  $\theta$ , the central ray of which intersects the screen at  $\epsilon_1$ , so that the axial distance of  $\epsilon_1 = \tan \theta r$ . The beam is now reverted through the aperture, supposed now to be filled by a lens having a flat focal field in the plane  $\eta \dots \eta_1$ , and its principal focus at  $\eta$  in this plane distant by  $r$  from  $c$  the centre of the aperture. Then at  $\eta_1$  will be formed an

\* See Appendix, Note I.

image of  $\epsilon_1$  as of a conjugate point at infinite distance from which a beam of light along the axis  $\epsilon_1 \dots c$  fell upon the aperture. The axial distance of  $\eta_1$  will be  $\eta_1 = \sin \theta r$  by equation (10) App. I., p. 429. This then will be a point within the antipoint formed by the aperture when fitted with a lens focussing at the distance  $r$  from the optical centre  $c$ . Similarly  $\epsilon_1$  will be the corresponding point in the plane of the screen in the diffraction fringe formed by the unfocussed beam. The point  $\epsilon_1$  cannot, however, as a rule be directly observed because, lying within the projection of the beam itself, it is drowned in the superior effulgence of the direct light. If then we wish to speak of the antipoint as the image of a diffraction fringe, it must be of the diffraction fringe formed at infinite distance. For the purpose of determining its magnitude, however, we may

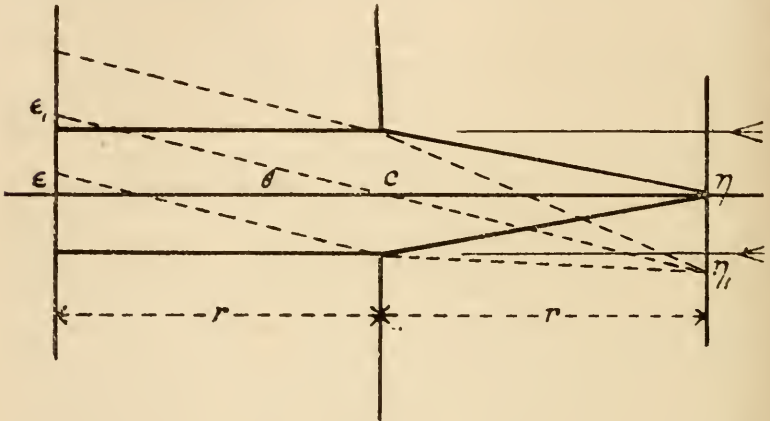

FIG. 94.

compare it with the point to which the central ray of the equiphasal beam would be deflected on a screen at a distance from the aperture equal to the distance of the principal focal plane, and then we shall have the following numerical relation:—

$$\frac{\text{Semi-diameter of the antipoint}}{\text{diameter of the fringe}} = \frac{\sin \theta}{\tan \theta} = \cos \theta.$$

From this equation a very important inference may be drawn. For the diameter (axial distance) of any particular phase zone  $F$  in the fringe is, as we have seen,

$$F = (\epsilon \dots \epsilon_1) = r \tan \theta = \frac{\sin \theta}{\cos \theta} r.$$

But  $\sin \theta = \frac{\phi \lambda}{2R}$  if we write  $R$  for the semi-diameter of the



aperture, and  $\phi$  for the phase expressed in wave-lengths—the phase value, as we may term it. Therefore

$$F = \frac{\phi \lambda r}{2 R \cdot \cos \theta} \dots \dots \dots (5)$$

Now we have seen that the radius of the corresponding ring in the antipoint =  $F \cos \theta$ . Therefore writing  $\rho$  for this radius, we have

$$\rho = \frac{\phi \lambda r}{2 R} = \frac{\phi \lambda}{2 \sin u} \dots \dots \dots (5a)$$

since  $\frac{R}{r}$  is the sine of the divergence angle  $u$ .

*Main Results of the Helmholtz Theory.*

From this expression for the radius of the antipoint several inferences may at once be drawn.

(1) In the first place, we infer that the successive phase-rings of the antipoint must be distant from the centre in the exact proportion of their phase-values. For,  $\lambda$  and  $u$  remaining constant, the value of  $\rho$  is simply proportional to  $\phi$ . That is to say, a focussed beam of given angular aperture in a given transparent medium has all its bright rings equidistant from one another, and so with all its dark rings, and has all its rings formed with radii having lengths proportionate to the phase-values of the several rings.\*

(2) In the next place we may note that the equation (5a)  $\rho = \frac{\phi \lambda}{2 \sin u}$  is wholly independent of  $r$ . We conclude, therefore, that the dimensions of the antipoint formed by a focussed beam depend upon the wave-length and the divergence angle only, and are entirely independent of the focal length. This agrees with the result of observation mentioned above (p. 403), and may be expressed by saying that the diameter of the antipoint is inversely proportional to the numerical aperture of the beam by which it is given off.

(3) In the next place, it can be shown by the same expression that the antipoint which a given aperture produces is, other things being equal, directly proportional to the radius of curvature of the wave-fronts which pass the aperture.

For equation (5a) can be stated alternatively thus:

$$\rho = \frac{\phi \lambda}{2 \sin u} = \frac{\phi \lambda r}{2 R}$$

\* It is not of any importance in the present connection to take notice of Sir George Airy's correction—of which Helmholtz is quite aware—of this result as applied to the innermost rings of the antipoint produced by a circular aperture. See Camb. Philosophical Transactions, vol. v. (1835) p. 283.

Now adopting the second of these expressions and assuming everything but  $r$  to be constant, we may write (5a) thus :

$$\rho = Cr. \quad . \quad . \quad . \quad . \quad . \quad . \quad . \quad . \quad . \quad (6)$$

It follows from this that no diffraction can arise in a focal plane where the radius of curvature of the wave-fronts = 0. It follows again that any disturbance caused by diffraction arising on the stage of the Microscope, can always be avoided by focussing the source of light upon the stage. Hence the value, for exact work, of what is known as critical illumination, and of condensers capable of accurate focussing.\*

(4) Finally, the phase remaining constant, if we change the wave-length and the divergence angle, we obtain an antipoint according to the law

$$\rho_\epsilon = \frac{\lambda_\epsilon}{2 \sin u_\epsilon} \phi = \frac{\text{a constant}}{n_\epsilon \sin u_\epsilon}$$

$$\therefore \frac{\rho_\epsilon}{\rho_\eta} = \frac{n_\eta \sin u_\eta}{n_\epsilon \sin u_\epsilon}, \text{ and}$$

$$n_\epsilon \sin u_\epsilon \rho_\epsilon = n_\eta \sin u_\eta \rho_\eta . \quad . \quad . \quad . \quad . \quad (7)$$

Comparing this equation with equation (4) (see above, p. 396), we see that antipoints are conjugate images of each other, and are formed and proportioned according to the sine law of image formation. This may fairly be described as the great result of Helmholtz' investigation.

*Diffraction in the Microscope.*

We are now in a position to renew the consideration of Helmholtz' proposition (p. 402), that the loss of resolution due to diffraction in the instrument is the same that would arise from viewing the image formed in the instrument through an aperture equal to that of the Ramsden circle. The question which we left over at p. 403 was whether diffraction arising in any other part of the instrument would make matters worse than this.

A reference to fig. 89 above, p. 401, in which the course of an axial and of an oblique beam are traced through an ordinary compound Microscope, will assist the enquiry. If we now consider first the axial beam it will appear that there is no mischievous diffraction beyond what is traceable to the Ramsden circle. For the beam which comes from the objective has the same numerical aperture as that which enters the eye-lens and, therefore, by equation (7) (see above), the antipoint produced by the objective

\* See Appendix, Note III.

in the object plane is the optical projection of that produced by the Ramsden circle. If, then, the Ramsden circle be not larger than the pupil of the observer's eye, the instrumental image of the central point will be seen exactly as it really is.

This implies, of course, that the entire beam which fills the aperture of the objective is focussed in the image. The case, then, of the oblique beam is somewhat different from that of the beam transmitted along the optical axis. For, if the other apertures are only just large enough to transmit the axial beam un mutilated, they will necessarily cut down the oblique beams to less numerical apertures than that of the axial beam and so impair the antipoint in the marginal parts of the field of the instrument. Take, for example, the oblique pencil from  $\epsilon_1$ . It falls excentrically upon the back lens of the objective, and consequently, if this back lens has no greater aperture than the optical projection of the front lens along the path of the axial beam, its edge will cut down the aperture of this oblique beam all through the instrument. In that case, the antipoint formed at  $\eta_1$  will be greater than the antipoint at  $\eta$ , and will be unsymmetrical. For the effect of the cutting down of the oblique beam by the two circular apertures in succession will be to give to the beam a sectional form as shown in fig. 95. Its antipoint will have approximately the same shape, with the long axis turned towards the centre of the field. For this reason it is scarcely possible to obtain, even with the most perfect optical arrangements, a really good resolution in the peripheral parts of the field of the Microscope. The aperture of the oblique beams which focus in those regions has usually been cut down by diaphragms placed either in front of or behind the principal diaphragm of the objective to something less and often greatly less than the aperture of the central beam.



FIG. 95.

It is not only in the marginal regions of the instrumental field that the deterioration due to this mutilation of the oblique beams manifests itself. The distorted antipoints produced by this means have a pernicious property of turning their long axes towards the centre of the field, and consequently they tend to produce their maximum disturbance there, where the resolution ought to be finest.

Fig. 96 illustrates this point by a diagram, in which five antipoints are shown in their mutual relations. The four external ones stand so far apart from the central one, that if they had the regular size and form, similar to the size and form of the central antipoint, they would not trench upon it at all. This is indicated by the four circular outlines touching the middle circle. But assume

that these peripheral antipoints become distorted into a prolate form with their long axes slightly more than twice the length of their shorter axes. Then the points of these distorted antipoints will overlap in the middle of the field, producing there an intercostal spot as shown.

Now, this diagram shows very imperfectly what happens in the Microscope when oblique beams, much mutilated by successive diaphragms, are admitted to the field of the instrument. The assumption that the long axes are double as long as the short axes is by no means an extravagant assumption since it implies only that one-half of an oblique beam transmitted by the first aperture has been intercepted by the second. And here we have only four peripheral antipoints shown out of the infinite number, which would in fact find place upon the ring in which these four are situated. It will

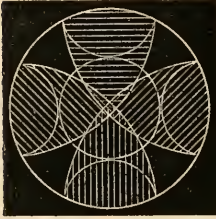

FIG. 96.

become evident upon consideration, that whenever the back lens of an objective is completely filled by the wave-front transmitted by the front lens from the central point of the field, that is to say, if it presents no appearance of unoccupied aperture as seen from along the axis of the instrument, it must cut down *all the* oblique beams transmitted by the front lens, and cut them down in much more than the simple proportion of their obliquity, if by this proportion we understand the proportion between the angular aperture of the lens itself, and the inclination of the axis of the oblique beam to the axis of the instrument. In that case, therefore, we shall have the various antipoints in successive rings of the field of the instrument; measuring outward from the centre; arranged somewhat as in the diagram (fig. 97).

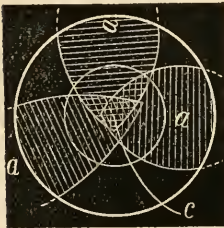

FIG. 97.

Here three excentric antipoints are shown, and for greater clearness they are arranged in different azimuths. It will of course be understood that each represents a complete ring of similar antipoints arranged about the centre of the field at a central distance indicated by the letter *a* from *c* the middle point of the field. The bounding circle indicates the diaphragm of the eye-piece, and it is assumed for the purpose of the diagram, that the most excentric beam brought to a delineated focus has had four-fifths of its full diameter cut off by the hinder diaphragm of the objective. It will surprise nobody who considers the state of the illumination produced in that way, that it should render all clear definition of detail impossible. It may be that even the largest antipoints here shown would give a well resolved

picture if all the antipoints in the picture were of the same size and shape. But with graduated antipoints arranged in a geometrical pattern, the background pattern of the mere blank field becomes so complicated and obtrusive that resolution of anything but strongly contrasted features is rendered thereby impossible.

This difficulty is not unknown to microscopists. The necessary limitation of the working aperture has been observed, notably by Mr. E. M. Nelson, who has recently made a communication to your Society upon the subject (*R.M.S. Journal*, vol. for 1901, p. 242). But it has not as yet, I think, received its explanation. For the benefit of Fellows and visitors this evening who may desire to test the explanation here proposed by an actual observation, there is arranged among the exhibits a piece of apparatus upon the plan of arranging a shutter within the tube of the Microscope just behind the objective, so that it can be very gradually introduced into the path of the beam and caused to cut down first the excentric and ultimately the central pencils unsymmetrically. As it is introduced a vague shadow, which denotes the advance of the invading distorted antipoints from the shutter side of the field, will be seen travelling across the object, and in this pernicious shadow, so tender as itself to be barely visible, all the delicate details of the picture will be seen to dissolve away.

It thus appears, that for fine resolution two conditions are essential, a wide angle to secure a small type of antipoint, and a clear course to secure the uniformity of the antipoint of that type throughout the field of the instrument.

The first of these conditions is secured by a wide angle for the beam which forms the image, an object which can be attained in various ways. But as a wide angle behind the objective involves loss of magnifying power, this condition is only consistent with high magnification on the further condition that the front of the objective has an angle commensurably wide. That is to say, it is attained by high numerical aperture, the virtue of which has been fully recognised, perhaps even somewhat over-estimated, for many years.

But the second of these conditions, that is to say, the clear course and consequently uniform antipoint, is very little understood and at the present moment only dimly recognised at all as a condition of the best performance. It must even be admitted that Helmholtz himself does not draw attention to it, and apparently did not consider the point. He assumed that all the antipoints with which he was concerned were of one size and form and worked out his conclusions accordingly. The practical importance of this point is, however, at the present day too great to be now passed over in silence. In order, however, to resume the thread of Helmholtz' paper, I will defer to a later paragraph the further discussion of this theme.

*The Measurement of N.M.P.*

Helmholtz then, having shown that resolving power depends upon the numerical aperture or, as he terms it, the normal magnifying power, of the beam transmitted by the objective, proceeds to suggest a mode of measuring this N.M.P. His plan is to use the Ramsden circle as a gauge. We have already seen (p. 410) that the antipoint of the reverted beam through the Ramsden circle projected on the image plane is of necessity the same as the antipoint of the beam received from the objective, whether with or without an eye-piece field-lens, for both the beam received and the beam emitted by the image have necessarily the same divergence angle. We set up the instrument then upon an object, and bring it into perfect adjustment. We next observe the magnification of the image and the diameter of the Ramsden circle. Taking this observed diameter (expressed in mm.) for our numerator, and for denominator the arbitrary constant 3, we obtain a fraction  $\frac{m}{3}$ , where  $m$  stands for the diameter as above defined of the Ramsden circle, and by it we multiply the observed magnification. The result is the normal magnifying power of the objective, which we may thus express:

$$M_0 = \frac{m}{3} M. \quad . \quad . \quad . \quad . \quad . \quad (8)$$

This is Helmholtz' proposed scheme of rating objectives.

Digressing for a moment from the Helmholtz paper to say a word upon the merit of this method as compared with the method now in vogue of rating objectives by the numerical aperture as read by an apertometer, I desire to draw your attention to the all-important consideration that N.M.P. can be estimated and is estimated, if properly ascertained, under working conditions; whereas for the purpose of an apertometer measurement the instrument is pulled to pieces and set to work under conditions which wholly destroy its power of fine performance. When an apertometer is used the index flame may show a falling off in brightness, betraying the gradual cutting down of the oblique pencils long before the edge of the aperture is reached, but there is nothing in the apertometer to show when this mutilation of the oblique beams will begin seriously to impair the performance of the instrument. Of the two conditions of fine resolution, the apertometer therefore measures only one and that the less important of the two; for Mr. Nelson's experiments already referred to show that when resolving power has been destroyed by cutting down the oblique pencils by a diaphragm placed behind the objective, it may be restored by cutting down all the beams, i.e. the central and oblique together, by means of a diaphragm in front of the condenser, thus

diminishing the numerical aperture and increasing the diameter of the antipoint in the centre of the field in reciprocal proportion, but restoring the uniformity of illumination which the first operation had disturbed.

Between these two methods of measuring resolving power there cannot therefore be, even for a moment, any question as to which is the more scientific. The apertometer is wholly misleading and incurably bad, for it cannot be applied under working conditions. Helmholtz' method, if properly applied with due precautions, tells us precisely what we want to know, namely what is the comparative capacity of a given objective for producing a finely resolved image under the conditions of actual use.

### *The Ultimate Limit of Resolving Power.*

Coming back now to Helmholtz' paper, our author, having thrown out this practical suggestion as to the rating of objectives, proceeds to discuss the theoretical question, "What is the ultimate limit of resolving power?" Speaking off-hand one might be disposed to say that since the picture formed by a lens is built up of antipoints, no object smaller than an antipoint could be delineated within it. And if an antipoint were a material object like the grain of a photograph, so that one antipoint could not penetrate another, this would be a perfectly sound conclusion. But an antipoint is a kind of diffusion disc, and there is no reason in the world why any number of antipoints should not occupy the same space interpenetrating one another like—what in truth they are—beams from contiguous lamps.

But although Helmholtz was quite well aware that you could picture, by means of antipoints, objects smaller than the antipoints themselves, he thought that objects would cease to be separately discernible in the picture if they were smaller than one-half the diameter of the false disc of the antipoint.

The diagram (fig. 98, plate VI.) will illustrate his view. Here four pairs of antipoints are shown in varying degrees of propinquity, the false discs only being taken into account. Case *a* exhibits separate discs and presents no difficulty. Obviously these represent distinct objects in the picture. Case *b* shows the two antipoints overlapping to the extent of one-fourth of the diameter of each. Here experiment shows that the eye distinguishes. In *c* and *d* this overlapping of adjacent antipoints is carried farther, and we may assume that in *d* it has been carried so far that the points in the object from which they start are no longer distinguishable by the eye. They are like irresolvable double stars in the heavens. At *c* we assume that they are in the critical position and may be described as just distinguishable or just indis-

tinguishable, as you like. Helmholtz thought that this point would be reached when the two antipoints overlap to the extent of one semi-diameter, i.e. when the edge of the one lies exactly on the centre of the other.

For this conclusion Helmholtz gives no physical reason, and no physical reason can be found. On the contrary, it can be shown—and I have developed the argument in the appendix (Note II.) to this paper—that there is strong ground in physics for concluding that antipoints may overlap to a much greater extent than that of the semi-diameter, and still yield fully resolved pictures. But Helmholtz seems to have relied upon experiments, and I shall best do justice to his paper if I quote it textually in this connection.\*

“We are here mainly concerned with the diffraction images which arise from an aperture of circular form. A bright point of light (the reflection of the sun from a thermometer bulb) seen through such an opening (a needle-prick in a card) appears, as is known, like a bright circular disc surrounded by rings alternately dark and bright. The apparent breadth of these rings reckoned from minimum to minimum, corresponds very closely to a visual angle of which the sine is  $\frac{\lambda}{d}$ , where  $\lambda$  is the wave-length of the incident light, and  $d$  the diameter of the opening. The outermost rings have almost exactly this breadth, the innermost are slightly broader; the radius of the central light disc is  $1.220 \frac{\lambda}{d}$ . Assuming that the smallest visual angle under which we can distinguish two fine bright lines from one another may be set down as one minute of angle, then fringes of the brightest greenish-yellow light, having a wave-length of 0.00055 mm., are visible when the diameter  $d$  of the opening is 1.89 mm. The spreading out of a bright point into a disc or a bright line into a stripe must evidently become noticeable with somewhat wider openings.

“If objects having distributed bright patches of surface are viewed through such openings, the diffraction figures of the several points of light upon such a surface will tend to overlap one another partially, so that the circular fringes of every several point cannot be separately recognised. Now it is clear that this result of diffraction which changes every point of light into a minute circular disc, must impair the definition of the object as definition is impaired in the eye by the minute diffusion circles which result from imperfect accommodation. Very small objects which are only discernible in the most sharply defined retinal images will then become unrecognisable.

“That this is so can be proved by a simple experiment. The most critical objects are gratings having alternate bright and dark stripes

\* Pogg., p. 570; Abh., p. 198.



formed of parallel threads, arranged side by side or drawn in black and white lines upon paper. Standing at such a distance from the grating that with full accommodation of the eye, he can with suitable spectacles just distinguish the lines of the grating from one another, the observer places in front of his eye a card in which several small holes of various diameters have been pierced and judges whether he can through these holes still see the lines of the grating and see them as well as without the card. The illumination of the grating must be very bright; one printed on paper, for example, may be illuminated by direct sunlight in order to secure the necessary brightness of the object as seen through the opening.

“By means of such an experiment I find that in fact a noticeable deterioration of the image is produced by an opening of 1.72 mm. diameter. This is much more pronounced if still narrower openings are employed.

“The grating can be replaced by a printed page, under suitable conditions of use, that is to say, if it be placed at such a distance from the observer that he can just read it perfectly. Then, if he views it through an opening of about 1 mm. diameter, he will find that it is difficult or even impossible to read it. But I find this experiment less delicate than that with the grating.

“Of course, in the making of these experiments care must be taken to secure the best accommodation of the eye; if that be imperfect it may happen that the interposition of the card will diminish the size of the diffusion circles on the retina, and so improve the image.”

There are two criticisms which must here be interposed in reference to this experiment. First, that it is an experiment upon the power of the eye to discriminate small parts of an image, and not upon the state of resolution of the image formed in the eye. If I shut my eyes and put my hands upon a number of coins lying side by side on a table I can count them with ease if they are half-crowns, because the individual coin is much larger than my finger tips. But if they are threepenny-bits, that is to say, just about the same size as my finger-tips, I have the greatest difficulty in counting them, and I suppose that if they were the size of Maundy pennies I could not count them at all. I should not know whether one, two, or three were under one finger at one time.

The same kind of difficulty arises when we try to estimate by sense impressions produced upon an organ like the retina—where nerve-ends are distributed, as in the finger-tips, at finite distances apart—the absolute state of resolution in an image formed upon the retina. It is nothing to the point that the power of discrimination in the retina is many hundred times greater—in the sense of being more subtle—than in the finger-tips. Notwithstanding its great refinement, the retina has a limited power of discrimination, and it may well be that an image, which to the eye appears

unresolved, may want nothing but enlargement of scale, to be seen fully resolved.

The second criticism is, that the experiment itself indicates that the limit which Helmholtz thus discovered was a physiological rather than a physical limit of resolving power. For it is to be observed that he reduced the aperture of his eye by nearly one-half, from 3 mm. to 1.72 mm., in order to produce "a noticeable deterioration of the image." Proceeding *pari passu* with the reduction of aperture there must have been a corresponding increase in the diameter of the antipoint, and no marked physical change would supervene when it reached the dimensions which sensibly modified his retinal picture. It is true, as he says, that if the limit of the discriminating power of the optic nerve be taken at one minute of angle, the smallest separately visible objects would be flanked by separately visible images at just about that distance, which he noted by observation. Thus a noticeable change would occur at this stage in the development of the antipoint; but it is a change related to the structure of the optic nerve, not of the image, and has therefore no direct bearing on the limit of resolving power in an optical instrument, of which the retina is no component part. The fact that Helmholtz could reduce the diameter of his pupil from 3 mm. to 2 mm. without detecting any deterioration of the image argues that the normal antipoint of the eye is much too small to affect the apparent resolution of the picture produced on the retina.

It is not very clear—at least it is not very clear to me, in reading Helmholtz' paper—what is the inference which he himself proposes to draw from these experiments upon the diminished pupil. But I rather gather that his idea was to find a more accurate measure than the mere average diameter of the pupil (3 mm.) for the aperture of the conventional eye upon which to calculate normal magnifying power. He actually says :

"Calculated by means of equation (12) the diameter of 1.89 mm. of the beam received into the eye corresponds for an angle of  $180^\circ$  aperture in the incident beam in air to a magnification of 264.5 times. For Microscopes with narrower angular aperture the corresponding magnification would be less. In accordance with this conclusion we find in Hugo v. Mohl's *Micrography* that amplifications between 300 and 400 times yield the best detail; while Harting in his newest Microscopes with very nearly  $180^\circ$  of angular aperture found magnifications of 430 to 450 times the best for the purposes of measurement."

Yet even so the argument seems very loose. The conformity is not at all strikingly close of Mohl's result, that amplifications of between 300 and 400 times yield the best detail, and of Harting's that 430 to 450 times are the best magnifications for the purposes of measurement, with Helmholtz' conclusions that deterioration of the image sets in when a normal magnifying power is exceeded which

he estimates at 266 times at most for dry lenses, such as Mohl and Harting appear to have been using. Altogether, this part of the paper, in which our author is seeking for a basis on which to ground his argument concerning the ultimate limit of resolving power, will probably strike the reader as being the least satisfactory part, and the least satisfactory by very much, of the whole paper.

Ultimately, after discussing various inconclusive experiments and observations, he fixes upon the image of a ruled surface seen through a rectangular opening as being the most available test of the physical limit of resolving power in optical instruments, and then he says :—

“It can be shown in the case of diffraction from a rectangular opening that the grating will appear as an uniformly illuminated bright surface when the diffraction fringe is equal in breadth to the interval between adjacent rulings. For circular openings the integration involved in the calculation of the light distribution is extremely laborious. If the diameter of a circular opening is equal to the side of a square, the outermost fringes in the spectrum of a bright point formed by the circular opening are of equal breadth with, the inner are of greater breadth than the fringes formed by the square opening. If, then, the square opening suffices to obliterate the structure of a grating when the distance from centre to centre of its lines equals the breadth of the diffraction fringes, this must equally befall in the case of the circular opening with its somewhat broader fringes. In what follows, I have therefore adopted as being within the limit of the indistinguishable distance in the object, the centre to centre distance of the outer fringes which a circular opening produces. It is not impossible that, by reason of a favourable disposition of the fringes, somewhat smaller objects may occasionally be half seen, half imagined. But certain and unambiguous discernment of the object can hardly be brought about in that way.”

Helmholtz here says, “It can be shown,” &c., but he nowhere unfolds the argument by which the conclusion so announced can be established. I have already mentioned the Appendix to this paper in which I have ventured to develop the argument leading to a contrary conclusion.\*

\* Fellows of the Society may remember that I exhibited some photographs taken with a lens the aperture of which had been covered by a diffraction grating, by way of enforcing the argument here referred to. But in the course of preparing this paper for publication I have seen reason to be dissatisfied with that experiment and therefore have omitted all reference to it in the revised proof. The matter is dealt with in the Appendix, Note V. As showing what can be done in the way of fine resolution, even with existing appliances, the following instances may be noted. Dr. Dallinger's measurement of the flagellum of *Bacterium termo* =  $\frac{1}{3004700}$  in., J.R.M.S., 1878, vol. i. p. 169. Mr. Nelson's photographs of diatoms which hang in the Society's rooms, and in which among other exquisitely fine details there may be discerned the angles of the hexagons in a *Pleurosigma angulatum* where the angular points extend  $\frac{1}{4880000}$  in. beyond the radius of the inscribed circle. But Dr. Dallinger's result must now be taken subject to Mr. Nelson's criticism in a paper presented to the Society on the 17th of June, 1903.

The remaining conclusion of Helmholtz' paper depends entirely upon this assumption concerning the limit of resolving power, and must stand or fall with it. Helmholtz points out, as has been already shown, that even with a divergence angle of  $90^\circ$  the antipoint is not infinitesimal but has a false disc, the semidiameter of which by equation (5a)  $\left(\rho = \frac{\lambda}{2 \sin 90^\circ}\right)$  is equal to  $\left(\frac{\lambda}{2}\right)$  half a wave-length of light. Now, if such an image were magnified the false disc would be magnified in the same proportion, and in that case the smallest possible antipoint in a magnified image would be proportionately larger than this smallest possible antipoint in the object-plane. But he rightly says it does not make matters any better to replace this minute image by a minute object, for although the object may be more finely resolved in fact than the image for which it has been substituted we cannot look at the object itself. We can only look at its magnified image, and, as we have seen, its magnified image must be formed by beams of light having a divergence angle so reduced that they yield antipoints upon the same scale as the magnified image of the objective antipoint first supposed. Now, it makes no difference in the result whether the antipoint is formed on the stage and magnified in the same proportion as the image, or formed in the image itself on the same scale of magnification. Therefore it comes to this in the end. We can determine the ultimate limit of resolving power in terms of the object by ascertaining the dimensions of the smallest detail that can be discerned in the image, and measuring its conjugate image projected on the stage. By the above computation this conjugate image is directly calculated, and thus Helmholtz came to the conclusion that the smallest object which can be resolved even by a perfectly corrected and ideally perfect lens, must be not less in diameter than half a wave-length of the light by which it is seen.

Passing now from Helmholtz' paper, I desire in conclusion to draw your attention to one or two practical deductions from the Helmholtz theory.

#### *Oscillating Screens.*

(1) First let me refer to the inconveniences which result from the progressive reduction of the divergence angle as the magnification of the image increases. Helmholtz has pointed out that this causes all obstructions in the eye or in the upper part of the instrument, to throw very black and conspicuous shadows, so that even the smallest speck of dust upon the eye-lens for example will be projected so as to become a prominent blemish in the image. The reason of this is that when the wave-front is much reduced in

diameter, say to the  $\frac{1}{1000}$ th part of an inch, a very small obstacle will wholly obliterate the light from a point on the object. Now, the obvious remedy for this defect is to spread out the contracted wave-front. And this is quite feasible. A reflecting or refracting screen interposed in the focal plane will scatter the light over as wide an angle as you please, and clear the image entirely of these intrusive shadows. You will this evening have an opportunity of judging for yourselves how great an improvement may thus be effected in the appearance of a highly magnified image, for in one of the Microscopes upon the table you will find a *Pleurosigma angulatum* magnified about 8000 diameters and thrown upon a ground-glass screen. Another Microscope standing beside it and fitted up as a twin instrument exhibits for comparison another specimen of the same diatom under the same magnifying power, but without the screen. It will of course occur to you that the grain of the screen must be exhibited as well as the detail of the picture, since both are focussed in the same plane, and this would inevitably be the case if the screen were at rest. To obviate this inconvenience it is kept in rapid oscillation in a more or less elliptical orbit. The movement, which is actually about three\* oscillations a second, is too rapid to be followed by the eye, which thus receives the impression of a delicately shaded picture thrown upon a structureless screen. In this way the picture can be magnified to any extent without impairment from the shadows of extraneous bodies.

Such an oscillating screen is capable of being made equally useful in photomicrography if the appliances are employed to which I propose presently to refer. But for that purpose the screen may oscillate much more slowly since the sensitive plate accumulates impressions during a comparatively long exposure. There is on the table a Microscope fitted with what I may perhaps call a compounding draw-tube for producing photographs and there you will see that the screen makes only about ten excursions in a minute. There is an advantage in this slow oscillation as it minimises the danger of shaking the instrument by the motion of the screen.

#### *The Compounding Draw-tube.*

(2) This leads me to speak in the second place of the appliances at present in use for photomicrography. Everybody must have been struck by the contrast, which the compact form of a modern high power Microscope presents to the clumsy appliances, considered

\* Subsequent experiment has shown that higher frequencies of, say, six to ten oscillations a second, give visibly better results than three oscillations if the illumination be brilliant.

necessary for the production of a photograph by the Microscope. The reason of the cumbersome form of the photographic apparatus is, of course, to be found in the use of the projection ocular with its great focal length. If, instead of a projection ocular, you employ a second objective, forming the image of the first objective in the ordinary way and then viewing that image as an object through a second Microscope, the whole of the necessary apparatus may be contained in a single draw-tube. On the table this evening there is a Microscope of this sort fitted with a compounding draw-tube which adds only 5 in. to the length of the instrument. It contains a  $\frac{1}{2}$ -in. for its second objective. In its present condition, with a  $\frac{1}{14}$  oil-immersion for its principal objective it produces at a distance of 10 in. from the stage negatives with a magnification of 400 diameters. The same magnification by means of a projection ocular would necessitate a back focal length of at least 28 in., and 28 in. of back focus implies mechanical contrivances for operating the fine adjustment, and therefore, the horizontal position and all the business of a photomicrographic outfit. Here you have nothing more cumbersome than the ordinary Microscope.

What then, it may be asked, is the advantage which makes the projection ocular in use so far preferable to the doubled objective as to warrant the expense and trouble involved in the use of the projection ocular? Theoretically the one appliance cannot give better resolution than the other, for we know by the Helmholtz theory that repeated magnification does not impair the resolution of the image, for image and antipoint are magnified together, provided that no supernumerary diaphragm cuts down the beam which carries the image from one focal plane to the next. But precisely in this matter of diaphragms the projection ocular has a great advantage over the doubled objective. For the projection ocular is placed well forward in the beam, where the wave-fronts are crowded together, and requires no lenses behind it. The course of the beam is, therefore, perfectly clear and under these conditions the highest magnifications can be obtained without sacrifice of resolution. The use of a compounding draw-tube, on the other hand, presents many difficulties. The first image fills the aperture of the second objective with very narrow and very widely separated beams of light, and it is not altogether easy to avoid mutilating the more excentric of these narrow beams by the edge of the aperture of the second objective. The mischief of this mutilation of the marginal pencils of light has been already explained and for this reason an image highly magnified in this way, if no precaution is taken to prevent mutilation, is little fitted for close examination although pictures at comparatively low magnification may be made so with complete success.

*Illumination of the Stage.*

It is, however, quite possible to guard against loss of resolution in this way by taking care to limit the luminous field of the instrument to so much only as is to be photographed. If all the transmitted light fall thus within the angle of the upper objective you will obtain very respectable pictures in that way. There is exhibited to-night a photograph of *Pleurosigma angulatum* magnified 2500 diameters which was made in this little Microscope with its home-made compounding draw-tube and without any screen. It is, as you will observe, much spotted with the shadows of specks of dust upon the lenses, but apart from that it is a passable photograph.

But, although much may thus be done with only the simplest appliances, the oscillating screen does so much to improve the pictures that I cannot imagine that when once its capabilities are known anybody who intends to do much in the way of photomicrography will work without it. It adds very little to the apparatus and it places this simple contrivance of the compounding draw-tube theoretically on a level with the projection ocular and its optical bench. In fact it is better, because stiffer than the optical bench. There is no risk whatever of displacement due to vibration with this appliance and you could work as easily on board ship as on shore.

By means of the screen we scatter the light of the image formed by the first objective, and so enlarge the angle of the beams which enter the second objective, thus filling its aperture and enabling it to yield a perfect reproduction of the image formed in the first focal plane.

The photographs which you see here this evening have all been produced by the simple apparatus that you see upon the table. My practice is to use, as the case may be, a  $\frac{1}{6}$  or  $\frac{1}{14}$  as the principal objective, and by doubling this with a  $\frac{1}{2}$ -in. to produce a negative with a magnification of about 200 or 400 diameters. Such negatives will easily stand camera enlargement up to four or five times, and I therefore print in the same Microscope, using the simple draw-tube and a 2-in. objective as the photographic lens, the negative being, of course, mounted on the stage. In that way anything up to 2000 diameters magnification can be obtained. Of the merit of the process you will judge for yourselves. My results do not compare with fine photomicrographs, for this is in many respects a makeshift piece of apparatus. In fact, I am not sufficiently well satisfied with any part of it to include a detailed description in the present paper, but such a description is at the service of anyone who is sufficiently interested to inquire for it. Perhaps I may be allowed to say here that my

screens are made by grinding cover-glasses to a fine grain and then bringing them to the exact condition required by rubbing a little white wax over the surface.\* In this way the scattering power of the surface can be regulated with some nicety; since it is easy to put more wax on or rub it off, until the exact condition is reached which gives the desired angle to the emitted light. But it will not be supposed that I can presume to recommend this as being the best plan of preparing these screens. I can only say that it answers. Probably other forms can be devised that will answer better. This is the best that I have thought of.

(3) The subject last discussed leads very naturally on to the discussion of the illumination of the microscopic field. It has been pointed out above (p. 412) that unequal and most mischievous illumination results from the overlapping of antipoints intruding from the margin into the centre of the field when the marginal beams have suffered mutilation. But as the subject is foreign to Helmholtz' paper—although very germane to his theory—it could not there be pursued. I propose to return to it now in order to point out the expedients by which this inconvenience may be avoided.

#### *Working Aperture.*

Foremost among these stands the expedient to which Mr. E. M. Nelson has drawn attention, of leaving a ring of "unoccupied aperture" in the back lens of the objective. This, of course, can only be effected by cutting down the numerical aperture of the admitted beam, but when it is once realised that  $\frac{\lambda}{2 \sin u}$  is not anywhere near the resolving power of a thoroughly corrected lens this will cease to be regarded as a formidable proposal. Moreover as, whether he likes to do so or not, the microscopist is obliged to shut his condenser down below the apertometer measurement of his objective if he wishes to obtain the best result from his instrument, the rule thus laid down must, with whatever protests, be recognised in practice.

#### *Dark-field Illumination.*

But another expedient which does not involve any loss of angle in the objective, and by which very fine resolution may be obtained, is that of dark field illumination. Here the marginal parts of the field emit no light and consequently there are no

\* Further experiment shows that lanoline or such-like grease is better than white wax for this purpose. White wax absorbs no little light. Glass ground to the exact grain required is better still.



invading antipoints to disturb the image formed in the middle of the field. It is well known that under these conditions low-angled objectives will give surprisingly fine resolution, the explanation being that all the antipoints, although large, are very approximately uniform in shape and size, and consequently no false lights obscure the shadows forming the image.

#### *Limitation of the Illuminated Area.*

By analogy to this known contrivance it seems to follow that resolution in the central region of the field may be promoted by any artifice which diminishes the brightness of the peripheral parts. In that case the shape of the source of light will appear to be a matter of importance, and a small disc of light which can be focussed upon the exact part of the object which we desire to examine, leaving the rest of the field in darkness, will be the best. From this point of view the edge of a lamp flame will be better than its broad side, but a spot of light—as on a lime cylinder, better still. Experiments fully substantiate this inference, and on the table to-night you will find a lamp so arranged as to illustrate the point. Two shutters are disposed in such a way that the one or the other can at will be interposed between the flame and the Microscope. The one shutter exposes so large an illuminating surface as to flood the whole field of the instrument with light; the other is pierced by a minute aperture which shows as a mere spot of light in the field, and must be moved to the part of the object which it is desired to examine. You will observe that the introduction of marginal light sensibly impairs the resolution at the centre of the field. Now this contrivance can be employed with wide-angled objectives, whereas the method of dark field illumination breaks down with them. This then is a peculiarly useful expedient since it enables the microscopist to use to the best advantage his objectives of highest power. Moreover, it would seem that, excellent as is the flame of the Microscope lamp it is not ideally perfect as a source of light, and that some convenient form of light-source which will emit a sufficient amount of light from a smaller and more symmetrical radiating surface is still to be desired.

#### *The Rating of Objectives.*

Finally, there is the very important question of the rating of objectives. A sketch has been given above of the method proposed—or to speak perhaps more accurately, suggested—by Helmholtz. The suggestion is scarcely in a shape sufficiently elaborated to be

called a proposal. Helmholtz appears to have been himself dissatisfied with the constants of his own standard eye, and probably would have recommended revision if the standard were to be adopted for general use. But the scheme is there, and it has already appeared by comparison how entirely unscientific is the method of apertometer measurement. We do not want to know what is the extreme angle of incident wave-front that we can squeeze into our objective if we release it from duty and flood it with light. We want, on the contrary, to know what is the widest angle that can be dealt with under the conditions of actual use, that is to say, with a certain breadth of field under full illumination, and the instrument yielding its best performance—or to adopt Mr. Nelson's nomenclature—we want to know its working aperture. This can be ascertained by measuring its normal magnifying power under properly determined conditions of use, but it cannot be ascertained, even approximately, by mounting an apertometer upon the stage and reading off the angle at which an ill-defined image of a flame is extinguished by the limit of aperture. It may be that the time has not yet come for elaborating Helmholtz' suggestion into a definite scheme, and no doubt it would be premature to ask at the present time for any authoritative adoption of even the best scheme that could be elaborated. But it is surely time to bring this long neglected proposal under consideration, and to endeavour by experiment and discussion to form the views, at present embryonic, of the world of microscopists concerning the theory and practice of objective rating.

---

## APPENDIX.

### NOTE I.—THE SINE LAW AND SINE-TANGENT RELATION.

The sine law and what I may perhaps be allowed to call the sine tangent law are of so great importance in the theory of optical instruments, that I will take the liberty of adding in this place a few observations which could not be introduced without too great a digression in what purported to be a *résumé* of Helmholtz' paper.

The proof of the sine law which is commonly put forward and known as Hockin's proof is faulty, for the reason that it applies only to an imaginary image of infinitesimal dimensions situated on the axis of the system.

Helmholtz' proof is much more adequate. It applies equally to all parts of the field of the instrument—not simply on the axis—and it shows

that the conditions which produce aplanatism in a centred system will of necessity also produce an undistorted image according to the sine law. But even Helmholtz' proof does not explicitly bring out the sine-tangent law, and as this is much less well understood than the sine law at the present time, it is, perhaps, not an impertinence to offer a further proof which will embrace both propositions in one demonstration.

Postulate. Let it be granted that any image-forming optical system which is capable of producing a regular image of any surface must be capable of forming a similar image of a wave-front which coincides with that surface and moves through the system.

This proposition is almost axiomatic, and is here put forward as sufficiently evident without formal proof.

We start, then, with a plane wave-front  $\epsilon \dots \epsilon_1$  in fig. 99; we assume

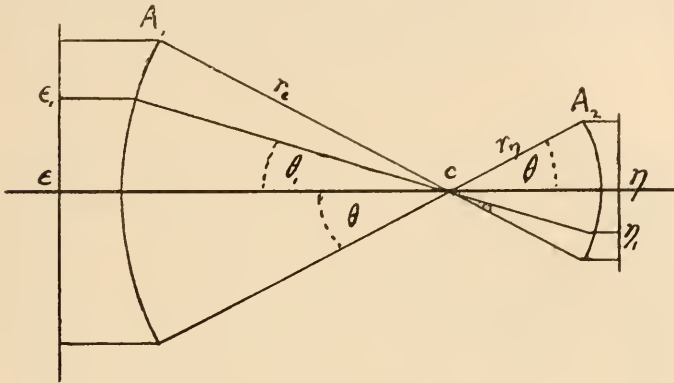

FIG. 99.

it to be propagated unchanged as far as  $A_1$ , and there converted into a spherical wave-front having its focus at C. It is quite immaterial by what apparatus this change of form is brought about provided that it is effected correctly. If correctly made the change must have produced a spherical image of the plane wave-front in which the distances of its parts measured upon the spherical surface are so rearranged that the original axial distances are preserved. That is to say, the law of formation is that all the rays travel in radial paths with equal velocities, and the criterion of resemblance is that every ray preserves, under all changes in the form of a wave-front, its angular position in the beam, so that at every point its axial distance  $\epsilon$  is

$$\epsilon_1 = \sin \theta_1 r, \dots \dots \dots (9)$$

$\theta$  being the angle which it makes with the axis, and  $r$  the radius of curvature of the wave-front at the point under observation.

The spherical wave-front having been formed, converges in con-

formity with the law of its propagation upon its centre C. Here the radius  $r$  becomes evanescent, and we have for the axial distance

$$\epsilon_0 = \sin \theta r_0 = 0.$$

But the angular magnitudes remain unchanged, and when the spherical wave-front is re-formed after passing the centre, its finite magnitudes are still determined by the formula

$$\eta_1 = \sin \theta_1 (-r).$$

Therefore the new spherical wave-front is an inverted image of the original wave-front.

We have next to suppose that in passing the aperture  $A_2$ , this expanding spherical wave-front is flattened by any process which preserves the resemblance. Then it will follow that the axial distances of the resulting plane wave-front must be given by the formula

$$\eta_1 = \sin \theta_1 (-r_\eta).$$

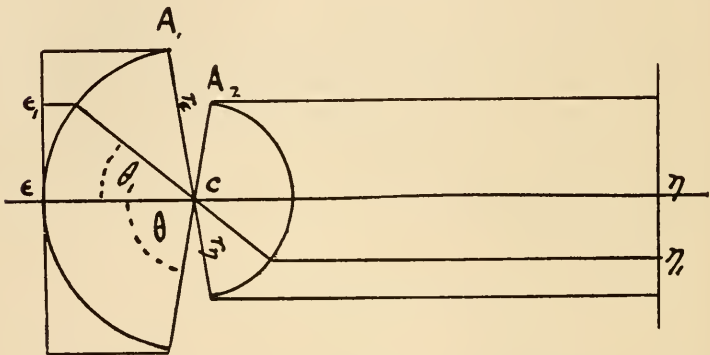

FIG. 100.

Now it is to be observed here that there is no question of focal planes. The image at every point in the system is perfectly correct and perfectly defined. The correctness depends upon the preservation of the sine relation which makes the axial distance equal to  $\sin \theta r$  and the definition results from the circumstance that the divergence angles  $u_\epsilon$  and  $u_\eta$  are each  $= 0$ . Hence the diameter of the diffusion disc at any point  $= 2 \sin u r = 0$ ; that is to say, we have perfect definition as well as true resemblance at every surface throughout the system.

It is also worthy of remark that nothing turns in this demonstration upon the particular magnitudes—linear or angular—employed. Thus, figs. 100 and 101 give two modifications of fig. 99, in which the diagram is varied in an extreme degree, and every magnitude is changed except the apertures and fields. But the relative proportion of the focal lengths  $r_\epsilon$

and  $r_\eta$  being preserved, the argument applies equally well to these so greatly altered figures. This will be evident without discussion.

In all cases the axial distance of the ray  $\epsilon_1 \dots \eta_1$ , whether on one side or other of the optical centre, is  $\sin \theta_1 r$ . If, therefore, we write  $\epsilon$  for the diameter of the object and  $\eta$  for the diameter of its image, we shall have

$$\epsilon = \sin \theta r_\epsilon \quad \eta = \sin \theta r_\eta \dots \dots \dots (10)$$

$$\therefore \frac{\epsilon}{r_\epsilon} = \frac{\eta}{r_\eta} \dots \dots \dots (10a)$$

This construction therefore can be employed to determine the magnifying power of any optical system, if we know the positions of the focal planes and optical centre, for we can always in theory place upon that optical centre a system such as that shown in fig. 101, and then, as we have seen, we shall get the dimensions of conjugate images in the two focal planes by the equation (10).

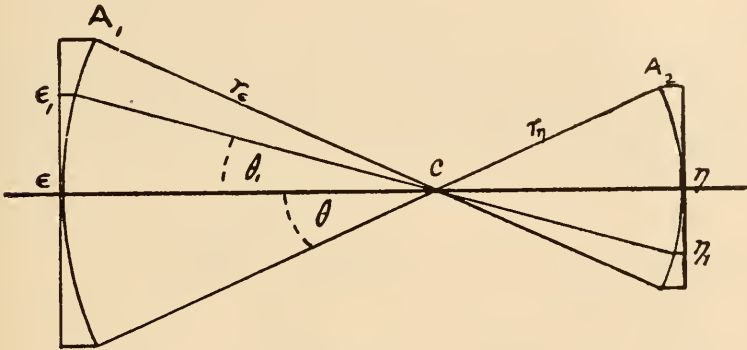

FIG. 101.

Now the optical centre can be at once determined from observations made upon the divergence angles  $u_\epsilon$  and  $u_\eta$ . Fig. 102 will make this clear.

Let it be supposed that we have two images formed at  $\epsilon$  and  $\eta$  respectively, and that the beam which focusses in them has the divergence angle  $u_\epsilon$  in the one plane and  $u_\eta$  in the other. The positions of these focal planes may then be taken to be given by direct observation.

Next let the rays from  $\epsilon$  and  $\eta$  be prolonged until they intersect one another in the point A. Then it is clear that the rays  $\epsilon \dots A$  and  $A \dots \eta$  must be proportional in length to the distances of the points  $\epsilon$  and  $\eta$  respectively from the optical centre, for both these are edge rays of their respective divergence angles, both therefore must by definition touch the edge of the aperture, and there is no other position for a common aperture which will satisfy this condition. If, then, we draw  $a_\epsilon \dots a_\eta$  parallel to the optical axis, and at such a height that the circular arcs  $a_\epsilon \dots C$ ,  $a_\eta \dots C$ , drawn about the centres  $\epsilon$  and  $\eta$

respectively, meet the axis in the common point C, we shall have found at C the optical centre; for  $\epsilon \dots C$  and  $C \dots \eta$  will be proportional to  $\epsilon \dots A$  and  $A \dots \eta$  respectively.

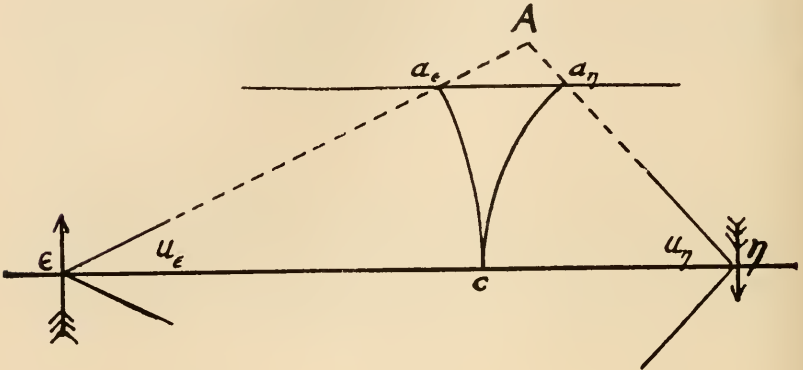

FIG. 102.

If, now, we apply to this system the rule already established in connection with fig. 101, we shall find that the equation (10) implies the sine law in its ordinary form as applied to the divergence angles  $u_\epsilon$  and  $u_\eta$ .

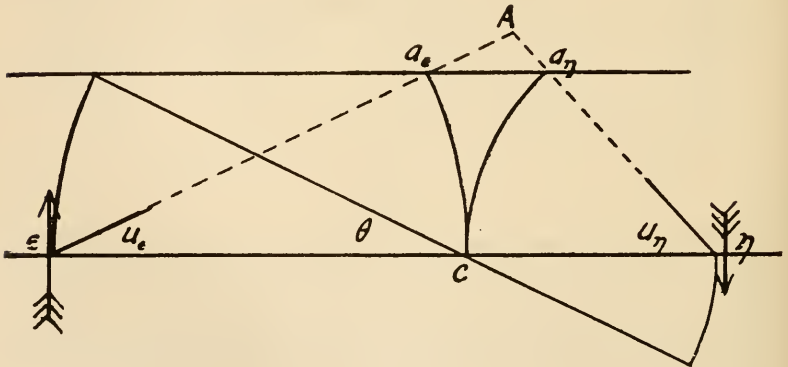

FIG. 103.

For consider fig. 103. Here we have figs. 101 and 102 combined, and we know therefore from (10) that

$$\frac{\epsilon}{r_\epsilon} = \frac{\eta}{r_\eta} \dots \dots \dots (10)$$

Also, we see from the diagram that

$$\sin \theta r_\epsilon = \sin u_\epsilon (\epsilon \dots a_\epsilon) ?$$

also that

$$\epsilon \dots a_\epsilon = r_\epsilon \dots \therefore u_\epsilon = \theta,$$

and

$$\sin u_\eta (a_\eta \dots \eta) = \sin u_\eta r_\eta = \sin u_\epsilon r_\epsilon \dots \quad (11)$$

\(\therefore\) Multiplying (10) by (11)

$$\epsilon \sin u_\epsilon = \eta \sin u_\eta \dots \dots \dots (12)$$

In this proof it has been tacitly assumed that we have the same refractive index behind as before the aperture. It is obvious that if the refractive index underwent a change between the two images there would be a corresponding change in (12), and from what has been already said (see above, p. 396) we know that the general expression is

$$n_\epsilon \sin u_\epsilon \epsilon = n_\eta \sin u_\eta \eta \dots \dots \dots (13)$$

which is Helmholtz' law.

The foregoing proof has proceeded upon the assumption that the image-forming aperture is capable of transmitting a plane wave-front. This is not necessarily the case. The image may be formed by a pin-hole, in which case only a minute axial pencil of the plane wave-front could pass it and no such image as is shown in fig. 99 of an extended plane wave-front could be formed. Yet a plane image can in that way be formed of a plane object which gives off beams of light with a finite divergence angle. The law of image scale in such a system remains therefore to be investigated.

Fig. 104 will serve for this purpose.

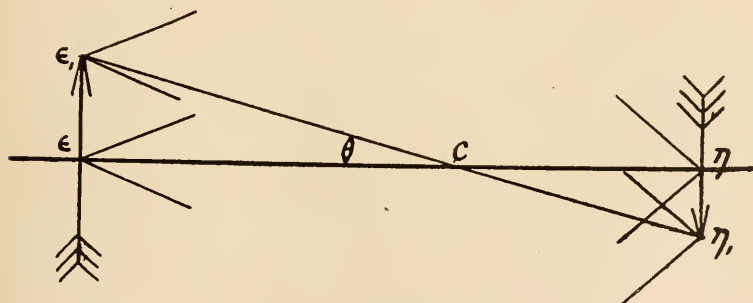

FIG. 104.

It is obvious at a glance that in this unfocused system the law is now not the sine law, for writing, as before,  $r_\epsilon$  for the distance  $\epsilon \dots C$  and  $r_\eta$  for  $C \dots \eta$ , we have for the positions of  $\epsilon_1$  and  $\eta_1$  respectively,

$$\epsilon_1 \dots \epsilon = \tan \theta r_\epsilon ; \quad \eta \dots \eta_1 = \tan \theta r_\eta.$$

The images are still proportional to  $r_\epsilon$  and  $r_\eta$ , for  $\tan \theta$ , like  $\sin \theta$ , is

constant throughout the system for a given ray. But the absolute axial distances are different, and different in the proportion  $\frac{\tan \theta}{\sin \theta}$ . It is evident that when  $\theta$  is large this discrepancy becomes enormous.

But the tangent law does not apply only to unfocussed beams. If we were to place a narrow-angled lens at C and cause it to rotate through the angle  $\theta$ , adjusting its focal length to the  $\sec \theta$  as it rotated, we should have focussed beams falling in the tangent positions. And it is equally plain that we should in that way obtain a flat field by an optical appliance which could not yield an image of a plane wave-front. Such systems are in use. For the photographic camera they are indispensable. In panoramic cameras the lens actually rotates. But the rotation is not necessary to the embodiment of the principle. All that is indispensable is that the focal length should vary with the position angle  $\theta$ , and in the ratio of  $\sec \theta$ . A fixed lens that satisfies this condition yields images on tangent scale.

The great advantage of a lens of that description lies in its breadth of field. The centred system, to use Helmholtz' term for the system first discussed, cannot cover a field any larger than its aperture. But this uncentred system, in which the optical axis wanders to all parts of the field, is limited only by the extravagant dimensions to which the tangent attains at very wide angles. Indeed, a panoramic camera, with a circular field, will take in an angle of  $360^\circ$ , and more too if you will let it. But then, of course, it substitutes the angle  $\theta$  for its tangent as the modulus of the image scale. This case, therefore, does not fall within our present scope, since we are only concerned with the formation of images in flat fields.

It may be useful, however, to point out that there are three and only three practicable image scales for aplanatic systems and that these three scales are related to one another as the sine, arc and tangent. The sine scale applies to centred systems with flat fields, the arc scale to systems centred or uncentred with spherical fields and the tangent scale to uncentred systems with flat fields. It is not possible to deal with the one system fully apart from the others for we may have a spherical image of a flat object or *vice versa* and again we may have a centred system with its fixed optical axis on one side of the aperture, and an uncentred system with its wandering optical axis on the other side of the aperture. We are at present, however, only concerned with the sine and tangent scales;—but even so it is simplest to begin by considering all three scales together.

Fig. 105 exhibits these relations at a glance. Here we have three fields which have a common point upon the common axis and a common position angle  $\theta$  at the common optical centre C. The scales are obviously proportional to the lengths which subtend this common angle, that is to say, they are proportional to  $\eta \dots \eta_s$ ,  $\eta \dots \eta_s$ , and  $\eta \dots \eta_t$  respectively. If we take the length of the arc as the standard magnitude and denote it by A we shall have for the sine scale  $S = \frac{\sin \theta}{\theta} A$ ,



subject to the proviso that  $\theta$  is not to be greater than  $\frac{\pi}{2}$ . For the tangent scale we have in like manner

$$T = \frac{\tan \theta}{\theta} A \dots \dots \dots (14)$$

subject to the same proviso.

So, again, connecting the sine and tangent scales directly, we have the equation

$$T = \frac{S}{\cos \theta} \dots \dots \dots (15)$$

These magnitudes are measured upon the surfaces in which the images are formed. It is obvious that the sine and tangent scales are fully comparable to one another, for they are represented by straight lines.

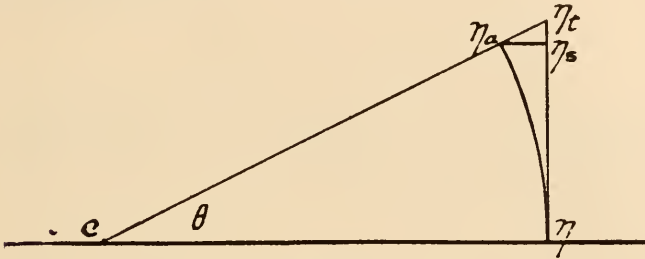

FIG. 105.

If in the arc scale we inquire for axial distances we find, of course, that they coincide with the scale measurement of the sine scale so that the sine law applies to axial distances in spherical fields.

But we have still to investigate these relations, substituting the divergence angle  $u$  for the position angle  $\theta$ , and in proceeding to do so it is useful to remember that as between conjugate images we may determine the scale of magnification by observations made in any part of the field. It is quite true, and will presently appear, that in the tangent field the magnifying power varies from zone to zone, whereas in the sine field it is uniform all over the area of the field and hence an unsymmetrical system giving a sine image in one field and a tangent image in the other, although it might be aplanatic, could not yield an undistorted image. But an image in one tangent field of an object in another tangent field is not impaired by the variation of magnifying power, for, as the position angle  $\theta$  is of necessity the same for both conjugate points, the change in apparent magnitude of the object is proportional to what the image gains by the alteration of focal length, and so the correctness of the projection is maintained. We must, therefore, postulate symmetry in this sense and may then assume uniform magnifying power in any kind of field.

That being granted, it is easy to see that we are at liberty to choose

for comparison any conjugate areas in the object and image fields and we shall find it convenient to choose for a criterion a radial line equal to half the diameter of the aperture and having one end on the axis. With this datum we construct the following diagram (fig. 106).

Here C is the optical centre; C . . .  $\eta$  the optical axis; A . . .  $\eta_\eta$  is a line drawn parallel to the axis from the edge of the aperture. It denotes, therefore, the projection of the aperture upon all the fields and wave-fronts through which it passes. We will select for comparison two fields distant  $r_1$  and  $r_\eta$  respectively from the aperture. If now we describe the spherical fields situate at these distances and draw the position angles  $\theta_1$  and  $\theta_\eta$  to the points where these two fields are cut by the edge line A . . .  $\eta_\eta$ , we shall evidently have two position angles equal

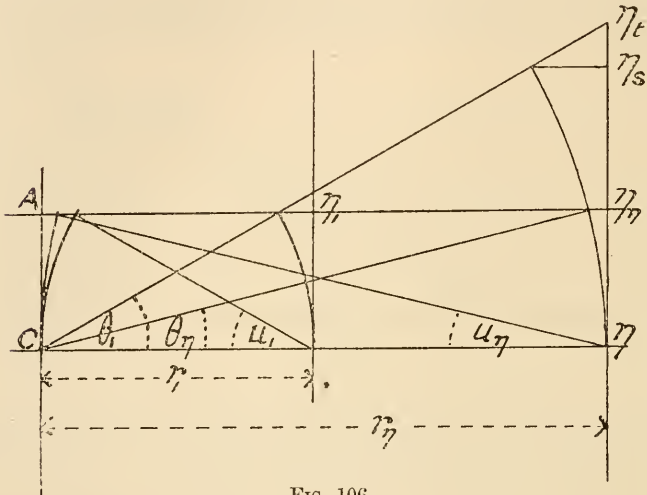

FIG. 106.

to the two divergence angles  $u_1$  and  $u_\eta$  each to each. We already know in general how these different image scales are related to their position angles, and as we have now obtained an equation between position angles and divergence angles we can extend the law to divergence angles.

Assume, then, two points  $\eta_1$  and  $\eta_\eta$  positioned by the angles  $\theta_1$  and  $\theta_\eta$  respectively in the  $r_1$  and  $r_\eta$  images. The images will be proportional to  $r_1$  and  $r_\eta$ , and therefore the magnitude A . . . C or its equivalent (which we will call  $\beta_1$ ) in the two image planes respectively will have scale values respectively proportional to  $\frac{1}{r_1}$  and  $\frac{1}{r_\eta}$ .

Now

$$\begin{aligned} \beta_1 &= \sin \theta_1 r_1 \\ &= \sin \theta_\eta r_\eta \dots \dots \dots (16) \\ &= \&c. \end{aligned}$$

Or substituting for these position angles the divergence angles equal to them we have for (16)

$$\beta_1 = \sin u_\eta r_\eta.$$

Furthermore, if we write  $\beta_s$  for the image in the sine field produced in the  $r_\eta$  plane, we shall have

$$\frac{\beta_1}{r_1} = \frac{\beta_s}{r_\eta},$$

and multiplying both sides of the last equation by this constant, we obtain

$$\frac{\beta_1^2}{r_1} = \sin u_\eta \beta_s.$$

Here the first member of the equation is a constant, and as the equation holds for all values of  $u_\eta$  the second member must be a constant also. Therefore

$$\sin u_\eta \beta_s = \text{a constant,} \quad \dots \quad (17)$$

which again is Helmholtz' law in a slightly altered form.

From this result it is a simple matter to infer the corresponding rule concerning images upon the tangent scale. For we know that  $\beta_t$  the image on the tangent scale, formed in the same plane of the same object, is related to the sine image  $\beta_s$  in the same way as the tangent and sine scales. Therefore by (15)

$$\beta_s = \cos u_\eta \beta_t.$$

Substituting this expression in (17), we obtain

$$\begin{aligned} \sin u_\eta \cos u_\eta \beta_t &= \text{a constant} \\ &= \frac{1}{2} \sin 2 u_\eta \beta_t. \quad \dots \quad \sin 2 u_\eta \beta_t = \text{constant.} \end{aligned}$$

The angle  $2 u$  (= the angular aperture) therefore takes the place of the divergence angle when we pass from the centred to the uncentred system, and it is of interest to note that upon the analogy of Helmholtz' law for the centred system we have now obtained for the uncentred system the rule

$$n_\epsilon \sin 2 u_\epsilon \beta_\epsilon = n_\eta \sin 2 u_\eta \beta_\eta. \quad \dots \quad (18)$$

It forms no part of my present purpose to pursue the discussion of these matters beyond the point now reached, but I have in conclusion to consider, and in the light of these results to offer a few observations upon, Hockin's proof of the sine law.

Hockin's proof may be shortly stated thus (fig. 107):\*

The line  $\epsilon \dots \eta$  is the optical axis;  $A_1 \dots A_2$  is an image-forming aperture;  $c_1 \dots c_2$  is the principal focal plane;  $\epsilon \dots \epsilon_1$  and  $\epsilon \dots \epsilon_2$

\* I borrow this statement of Hockin's proof with slight modification from Prof. Sylvanus Thompson's translation of Lummer's work on 'Photographic Optics,' but since this paper was written have become aware that it does not quite accurately represent the original. This is fully explained in the additional note at the end of this Note I.

are two plane wave-fronts at an angle to one another as shown;  $c_1$  and  $c_2$  are the two points in the principal focal plane in which they respectively come to focus;  $\eta \dots \eta_1$  is the spherical image of  $\epsilon \dots \epsilon_1$ , and  $\eta \dots \eta_2$  is the spherical image of  $\epsilon \dots \epsilon_2$ . In this figure four optical paths are traced, and our author first shows that they are all equal. This is easily done, for they are paths connecting conjugate points on two wave-fronts and their images. They must therefore at least form pairs of equal paths, for the two rays from the wave-front  $\epsilon \dots \epsilon_1$  to its focus  $c_1$  must be optically equal to one another, as also the two rays from its image  $\eta \dots \eta_1$  to the same focus. Therefore the total path  $\epsilon \dots \eta = \epsilon_1 \dots \eta_1$ .

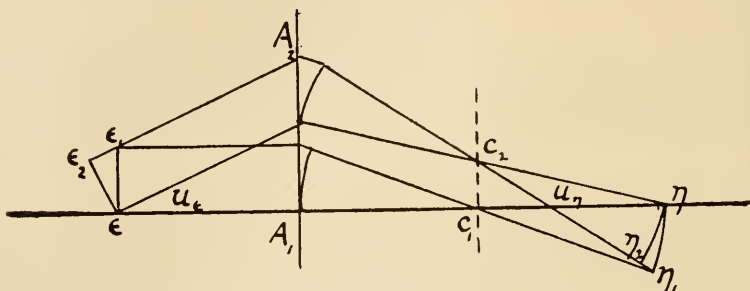

FIG. 107.

In like manner, it can be shown that

$$\epsilon_2 \dots \eta_2 = \epsilon \dots \eta.$$

But since  $\epsilon_1 \dots \eta_1$  and  $\epsilon_2 \dots \eta_2$  are both equal to  $\epsilon \dots \eta$ , they must be equal to one another. Now, tracing these two paths on the diagram, we observe that the part from  $\epsilon_1$  to  $\eta_2$  is common to them, and deducting this common part we are left with  $\epsilon_2 \dots \epsilon_1$  at one end, and  $\eta_2 \dots \eta_1$  at the other end, which therefore must also be equal to one another.

We have therefore the two triangles  $\epsilon \epsilon_1 \epsilon_2$  and  $\eta \eta_1 \eta_2$ , so proportioned that the perpendicular  $\epsilon_1 \dots \epsilon_2$  of the one is equal to the perpendicular  $\eta_1 \dots \eta_2$  of the other. As shown in the diagram,  $\eta \eta_1 \eta_2$  is a curvilinear triangle, but if we assume that the wave-fronts are made extremely narrow, it will approximate in the end indefinitely to a rectilinear triangle, its perpendicular  $\eta_1 \dots \eta_2$  always remaining equal to  $\epsilon_1 \dots \epsilon_2$  and its angle at the point  $\eta$  being equal to the divergence angle  $u_\eta$ . In like manner, the angle at  $\epsilon$  of the triangle  $\epsilon \epsilon_1 \epsilon_2$  is equal to the divergence angle  $u_\epsilon$ . So much being premised, we now observe that

$$\sin u_\eta (\eta \dots \eta_1) = \sin u_\epsilon (\epsilon \dots \epsilon_1),$$

but subject to the proviso that the magnitude  $\eta \dots \eta_1$  is so small that although it actually has the form of an arc, that arc may be identified with its own tangent.

Now this, it will be seen, falls very far short of being a proof of the sine law, as established by Helmholtz. And the reason is quite clear. Hockin has endeavoured to establish the relation between a plane object and its spherical image, and between them the relation actually does not hold. It is true, as we now know, for the axial distance of  $\eta_1$ , but for the distance  $\eta \dots \eta_1$  measured on the sphere, if that distance has any finite magnitude, it is not true.

But Hockin, although he failed of proving the sine law, did not fail by much, and a very slight modification of his proof makes it perfectly valid. In fig. 108 the essential parts of Hockin's diagram are reproduced with the addition of a second aperture and lens to give a flat form to the image  $\eta \dots \eta_1$ , and then it will be seen that it can be used for the proof of the sine law.

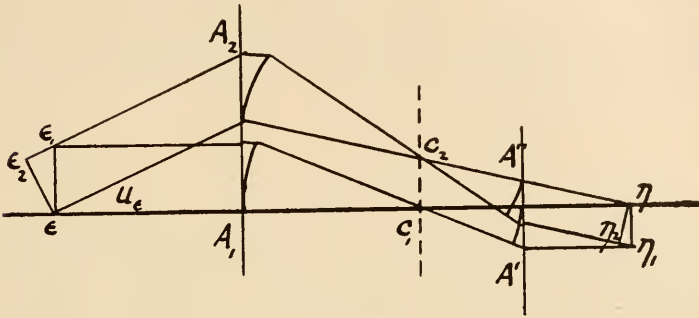

FIG. 108.

Here the proof concerning the equality of all the optical paths remains unaltered, for the second lens has only altered the form of the transmitted wave-fronts, they still remain the identical wave-fronts and therefore equidistant at every point from their foci  $c_1$  and  $c_2$ . It follows, therefore, that  $\eta_1 \dots \eta_2$  is in this arrangement, as in the original, equal to  $\epsilon_1 \dots \epsilon_2$ , and the two wave-fronts  $\eta \dots \eta_1$  and  $\eta \dots \eta_2$  are, by hypothesis, perpendicular to the rays along which they travel. Here, then, we have a rectilinear, right-angled triangle, having its perpendicular  $\eta_1 \dots \eta_2$  equal to  $\epsilon_1 \dots \epsilon_2$ , and its angle  $\eta_1 \eta \eta_2$  equal to the divergence angle  $u_\epsilon$ . Therefore

$$\sin u_\eta (\eta \dots \eta_1) = \sin u_\epsilon (\epsilon \dots \epsilon_1) ;$$

and the proof under these conditions applies to conjugate images  $\epsilon \dots \epsilon_1$  and  $\eta \dots \eta_1$  of any magnitude. But the conditions are that there shall be an optical centre  $C_1$ , at which the positioning angle  $\theta$  can be measured, and on either side of this centre a refracting surface distant from it by its principal focal length to render the direct and the reverted wave-fronts flat before they reach the image-plane. Hockin's construction does not satisfy this latter condition, and hence the failure of his proof.

*Additional Note.*

Since the reading of this paper Dr. G. Lindsay Johnson has very obligingly drawn my attention to a paper by Prof. J. D. Everett, which appears in the 18th volume of the *Proceedings of the Physical Society*, p. 166. In that paper Prof. Everett animadverts upon the form of Hockin's proof here discussed, and reproduces the original form from the *Journal* of this Society, 1881, ser. 2, iv. p. 337.

Of that original proof it would not be correct to say that Hockin's construction does not satisfy the condition of yielding a plane image of a plane object. On the contrary, his construction is sufficiently general to include both figs. 107 and 108 of the foregoing diagrams, and the mathematics of Hockin's own proof cannot be called in question. But the failure to isolate the case of the plane image of a plane object (fig. 108) is itself a vice. The proof, even in its authentic form, is too general, and by reason of this generality is unnecessarily limited to the case of infinitesimally small images.

## NOTE II.—THE ULTIMATE LIMIT OF RESOLVING POWER.

Helmholtz, as is stated above (p. 416), lays down, and without proof, the proposition that adjacent lines in a ruled surface will be indistinguishable if their diffraction fringes overlap completely, so that the free edge of the one lies upon the engaged edge of the other. This is the same thing as saying that they will be indistinguishable if their adjacent edges lie nearer together than the length of one-half of the diameter of the false disc of the antipoint, for, as we have seen, the antipoint is the image of the diffraction fringe surrounding a luminous point. The difficulty of dealing with this proposition arises from the fact that Helmholtz does not, in fact, adduce any proof of it, so that there is nothing but his *ipse dixit* to be met. But perhaps it is not illegitimate to supply this defect from another source, and as Lord Rayleigh has laid down and discussed what appears to be in substance the same proposition in an article on "Resolving or Separating Power of Optical Instruments,"\* I borrow the following demonstration from that source. To prevent any misconception it should be added that Lord Rayleigh's paper is written with special reference to the spectroscope and that its author is not, so far as I am aware, directly responsible for the proposition that half a wave-length of light is the physical limit of resolving power in the *Microscope*. But the passage which I propose to quote appears to be equally applicable to both instruments, and in any case furnishes material by the aid of which the case of the *Microscope* may be very usefully investigated.

"The curve A B C D represents the values of  $u^{-2} \sin u^2$  from  $u = 0$  to  $u = 3\pi$ . The part corresponding to negative values of  $u$  is similar, O A being a line of symmetry.

\* Scientific Papers, Lord Rayleigh, vol. i. 1869-1881, p. 420.

“Let us now consider the distribution of brightness in the image of a double line whose components are of equal strength and at such an angular interval that the central line in the image of one coincides with the first zero of brightness in the image of the other. In fig. 1\* the curve of brightness for one component is  $A B C D$  and for the other  $O A' C'$ ; and the curve representing half the combined brightnesses is  $E' B E F$ . The brightness (corresponding to  $B$ ) midway between the two central points  $A, A'$  is  $\cdot 8106$  of the brightness at the central points themselves. We may consider this to be about the limit of closeness at which there could be any decided appearance of resolution. The obliquity corresponding to  $u = \pi$  is such that the phases of the secondary waves range over a complete

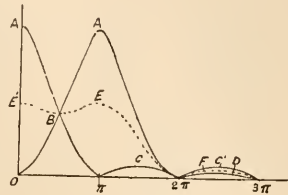

FIG. 109.

period, i.e. such that the projection of the horizontal aperture upon this direction is one wave-length. We conclude that a double line cannot be fairly resolved unless its components subtend an angle exceeding that subtended by the wave-length of light at a distance equal to the horizontal aperture.”

Now, it is to be observed, concerning this proof, that the light-intensity curve here shown is not the light-intensity curve of a very narrow rectilinear surface—such as would be commonly called a line—but on the contrary, it is the light-intensity curve, calculated for a mathematic point, such being assumed to be the source of light. Such an imaginary source differs, therefore, from any possible source of light in the important particular that it has no radiating surface and its light-intensity curve does not, in fact, exhibit the properties of a light-intensity curve derived from even the smallest imaginable surface. It represents only the infinitesimal element of such a curve from which the curve itself must be derived by integration. Treating it as such, it is easy to show that as a matter of theory, the semidiameter of the antipoint is not the limit of resolving power in a perfect instrument.

This may be shown without any recourse to abstruse mathematics by a very slight modification of Lord Rayleigh’s diagram. Let it be assumed that four “lines” delineated by means of antipoints such as Lord Rayleigh has figured lie side by side, distant  $\frac{1}{16}$  of a wave-length from one another. We may treat such a group as constituting a quasi-surface. It will be a narrow surface, for its breadth is but  $\frac{1}{2} \lambda$ , and it will be visibly an unbroken surface if we assume that two lines lying within  $\frac{1}{16} \lambda$  of one another will be indistinguishably fused together in the optical image. Let us next assume that in place of the mathematical lines of fig. 109 we have two such narrow surfaces lying side by side with an interval of  $\frac{1}{2} \lambda$  between them. We shall then obtain a result indicated by fig. 110. Here, in addition to the antipoint curves, we have five total illumination curves laid down. The two antipoints marked 1...1 will yield the total light curve I in fig. 109. The pair marked 2...2 will in like manner yield the total light curve II, and so of the re-

\* Fig. 109 in this paper.

maining pairs 3...3 and 4...4. If now we add these four resultant curves together in order to obtain a grand total light curve, we produce a curve which being reduced to a convenient scale, takes the form shown in fig. 110, V. Now here it is to be observed that between the maximum and minimum points the difference is not 19 p.e., as in curve

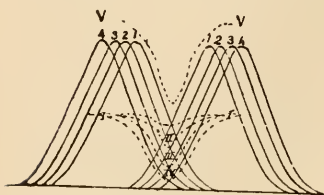

FIG. 110.

No. 109, but 50 p.e. Lord Rayleigh supposes that a difference of 19 p.e. in brightness in the interval between two bright lines is just sufficient for resolution. If so, then it is clear that with two groups of lines such as we have here the resolution would be complete. It is to be further remarked that the figure which yields this result does not really represent even a colloquial line, but rather a small aperture, of which the  $\frac{1}{4} \lambda$  with which we have credited it is the larger dimension. For it is clear that if there were other antipoints seated along these lines before and behind the plane of the paper, they would push their toes—so to speak—under the summits of the antipoints bisected by the plane of the paper on their own side of the division and so produce a further increase in the maximum brightness. It is of course true that they would raise the brightness of the minimum to some extent in the same way, but not to the same extent, for not even the front row of antipoints could add quite one-half as much to the brightness of the minimum as to the brightness of the maximum, and the hinder rows would add much less than half. Hence, although the antipoints from both sides combine to raise the brightness of the minimum, whereas those only from one side contribute added brightness to the maximum, the effect so produced when there is an interval of  $\frac{1}{2} \lambda$  between the nearest lines of the two systems must be to heighten the resolution of the bright lines. It appears certain, therefore, that these two bright “lines” lying at an interval of  $\frac{1}{2} \lambda$  from one another would be fully and even brilliantly resolved in the image formed of them by a perfectly corrected lens.

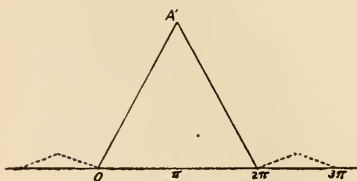

FIG. 111.

The matter thus set at large demands fresh and attentive consideration, and perhaps I may be permitted, without attempting an exhaustive treatment of it, to contribute the following observations to its discussion. Assume for the sake of simplicity that the light-intensity curve of the antipoint has the simple form shown in fig. 111. (This form does actually correspond to the light-curve for the antipoint of a square aperture along a section parallel to one of the sides of the square.) Further, for the sake of simplicity again, let us ignore the bright rings denoted by dotted lines, and assume that the section represents a solid of rotation, so that the antipoint curve will present the same contour—as in the case of the antipoint formed by a circular aperture—on all



aspects. We thus arrive at an upright cone, of which the base measures  $\lambda$  and the height is proportional to the amplitude of the undulation. The cone, therefore, may be formed with any angle, and in fig. 111 it is shown with an inclination equal to the mean slope of the curve in fig. 109, the corresponding points being denoted by the same letters in both diagrams.

Such being the light-intensity of the antipoint, suppose that it is moved along the path denoted in fig. 112, thus producing an optical line. It is plain that the line will be fringed by a pair of diffraction

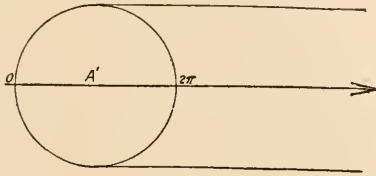

FIG. 112.

bands each  $\frac{1}{2} \lambda$  in breadth, and in which the light-intensity at any point will be proportioned to the area of those sections of the cone which have passed over the point. We thus obtain a new light-intensity curve as shown in fig. 113, of which the ordinates are proportional to the hyperbolas that can be cut from the antipoint cone by planes parallel to the axis. Here then we have a new form of light-intensity curve, and leaving out of account the terminals of the line, we observe that the

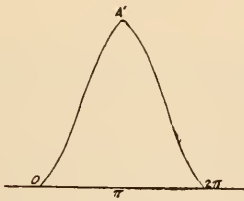

FIG. 113.

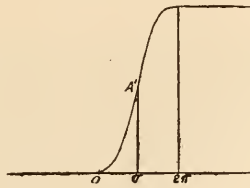

FIG. 114.

form shown is not now a solid of revolution but a moulded volume bilaterally symmetrical about the vertical plane in which the line lies.

Having thus obtained our image-line, we may proceed to develop an image-surface from it by causing it to move parallel to itself over the area to be depicted. The result is, of course, an accumulation of light on every point in the surface proportional to the area of the section of the fringe-curve which has passed over that point, and we thus obtain a final curve as shown in fig. 114, where the ordinates of the new curve are proportional to the areas of the curve in fig. 113. To save space this curve is drawn to a reduced scale—one-half the scale of fig. 113.

Comparing this with the preceding curves, there are several points which deserve notice. In the first place, the base of the curvilinear area has, as before, a diameter  $= \lambda$ . But now the symmetry is not bilateral. On the contrary, the ordinate of the curve at a distance  $2\pi (= \lambda)$  from its origin is double the height of the ordinate at the middle point of the base  $A'$ . Furthermore, the two halves, upper and lower, of the curve are now equal and similar.

Let us now make once more, with this new curve, the experiment illustrated in fig. 109. This is shown in fig. 115. In this diagram the total light-curve, shown by the dotted line, has been removed from the middle of the figure to its natural place on the scale, and it will be observed that owing to the similarity of the lower and upper halves of the curves the total light is now uniform all over. It is to be observed also that the illuminated surfaces (represented by their sections beneath the light-curves in the diagram) are now in contact with one another, for the point  $A'$  stands vertically over the edge of the illuminated area. This case, therefore, in which the light-intensity curves of the adjacent edges of two infinite surfaces bisect and exactly supplement one another,

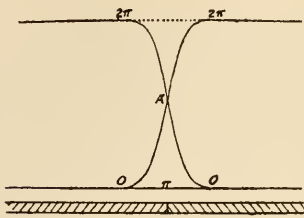

FIG. 115.

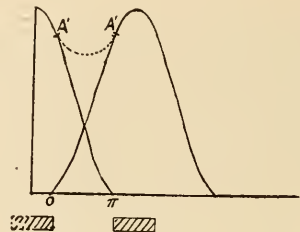

FIG. 116.

corresponds to a state of things in which the surfaces are in physical contact, and not to a state of things, as supposed by Helmholtz, in which they are separated by an interval of  $\frac{1}{2} \lambda$ .

But suppose, further, that the surfaces do not extend for indefinite distances away from the line of contact but are very narrow, that is to say, less in diameter than  $\frac{1}{2} \lambda$ , the distance for which the fully developed light-intensity curve extends back over the illuminated surface. In that case the area of the fringe-curve which passes over any point in the formation of the surface will be proportionably reduced, with the general result that the final curve will become unsymmetrical, the lower half growing hollower and the upper half being cut short. Fig. 116 shows the light-intensities across a narrow band assumed to be  $\frac{\lambda}{8}$  in breadth. The intersection of two such light-intensity curves is shown, together with the total light curve; from this it appears that even with such narrow surfaces as these, there is a falling off of illumination in the middle of the half wave-length gap between them which amounts to 25 per cent. Thus, in this extreme case where our finest existing instruments would certainly fail to produce a resolved image, we find

the conditions satisfied which Lord Rayleigh lays down as necessary for just perceptible resolution. Incidentally it thus appears that Dr. Dalling's famous measurement of the flagellum of *Bacterium termo*, with a breadth of about one-quarter of a wave-length, would be well within the capabilities of a perfectly corrected lens. Ultimately, if the breadth of the luminous surfaces were indefinitely cut down we should, of course, return to the fringe-curve of fig. 113 from which we started.

Finally, it appears that the magnitude  $\frac{\lambda}{2}$  to which so much importance has for a long period of time been attributed, even by physicists of the highest standing, as setting the ultimate limit of resolving power, is in truth quite innocent of any such propensity, and that its bad reputation is owing simply to an oversight in the conduct of a calculation. The oversight would have been unimportant if it had led only to a misconception as to the form of the light-intensity curve at the boundary of a bright surface, for the contours of one-half of the antipoint-curve and of the total light curve are in fact very nearly similar. But the importance of the oversight lies in this, that it leads to misconception as to the position of the light-intensity curve in relation to the object. The radiant point lies in the case of the antipoint-curve under the highest point of the curve, and in the other case the outmost radiant point of the surface lies some distance beyond the highest point of the curve. Hence the edge of the luminous surface has been displaced by what amounts in the case of a large surface to  $\frac{1}{2} \lambda$ , and this has led to the inference that the appearance of a continuous surface would be seen when there was in fact a gap of  $\frac{1}{2} \lambda$  bridged over by diffracted light.

NOTE III.—NOTE TO PAGE 410.

It may be well to add an explanation of the rule deduced on p. 410 concerning the absence of diffraction from a focal plane. This does not, of course, imply that an aperture ceases to produce diffraction if light be focussed in its plane, although this seems to have been supposed. Helmholtz himself describes the failure of an experiment, planned apparently on the supposition that the focussing of the source of light within an aperture, would entirely suppress *all diffraction whatsoever* \* from that aperture. But any such impression must be due to a mere oversight. For there passes with the focal light, light that is derived from wave-fronts not yet brought to focus in front of the aperture, and if we make our arrangements so that the eye focusses upon one of these wave-fronts it becomes the effective source of light, and the focal plane in the aperture only a region in which the light from that comparatively feeble source has to make its way through much extraneous light from other sources. Hence, it is always possible to demonstrate the diffraction from any aperture however illuminated. What the rule deduced on p. 410 tells us is that diffraction from the aperture in question will be entirely suppressed in all focal planes conjugate to the plane of the aperture.

\* Pogg. Ann., 1874, Jubelband, pp. 577, 578.

Now if that plane be occupied by focal light compared to which all neighbouring light must be feeble, we may be sure that the image produced by the focal light will not be greatly disturbed by the diffraction from unfocussed wave-fronts.

NOTE IV.—DR. FRIPP'S TRANSLATION OF HELMHOLTZ' PAPER.

Readers of Dr. Fripp's translation of Helmholtz' paper, referred to in the headnote under the titles of the *Monthly Microscopical Journal* and the *Proceedings* of the Bristol Naturalists' Society, should be warned that the diagram which appears as the second diagram in that paper—to illustrate equation (6)—is not in the original paper and is entirely incorrect. Helmholtz postulates a small plane area for his object  $dS$  and its plane image  $d's$ . Dr. Fripp has fallen into the error of translating the word *Flächenelement* used by Helmholtz by the word "point," with the result that the entire passage relating to equation (6) is unintelligible in his translation. But as I am compelled to publish this criticism of Dr. Fripp's work I trust that I may be allowed to add that this one is, so far as I know, the only serious blot on a piece of translation which is otherwise admirable, both for accuracy of rendering and for felicity of style.

NOTE V.—NOTE TO PAGE 419.

A diffraction grating produces not one only but three diffraction fringes on three different scales of magnitude. The broadest, which may be called No. 1, is due to the single bright line of the ruling, and its breadth is inversely proportional to the breadth of that line—the luminous component of the grating. But this diffraction fringe is so masked by the other two as to be scarcely discernible. Fringe No. 2 is the most conspicuous of the three. It is proportional inversely to the breadth of the grating element consisting of one bright and one dark component, and it passes from maximum to minimum brightness in an angular breadth comprising one half set of phase values. In the common case, therefore, of a grating with bright and dark lines of equal breadth, the breadth of fringe No. 2 is one-fourth part of the breadth of fringe No. 1. It is a comparatively brilliant object, and is commonly spoken of as *the* fringe formed by its grating. Fringe No. 3 is formed by the entire surface occupied by the grating operating as a single aperture. It is inversely proportional to the whole diameter of the grating, therefore, and its breadth has no definite relation to the dimensions of the other two fringes. But, as a rule, it is microscopically small, and for that reason it is usually ignored altogether. But when the question is one of testing by experiment the resolving power of a given antipoint the presence of this minute diffraction fringe cannot be ignored, if it be present, for it will itself be the principal factor in determining the state of resolution of the resulting image.

EXPERIMENTS SHOWN AT THE MEETING.

1. Showing the dependence of the diffraction pattern upon the radius of curvature of the wave-front which passes the aperture.—In this experiment a diffraction grating is mounted on the stage. The object is the image formed by the condenser of the slide mounted in front of the lamp. By moving the condenser up and down its focal plane can be made to coincide with the diffraction grating on the stage or to lie beneath it; the distance between the focal plane and the diffraction grating being, of course, the radius of curvature of the wave-front. It will be seen that as the focal plane approaches the grating the displacement due to diffraction diminishes, and when the two coincide it disappears. The two diffraction gratings which lie side by side on the stage are ruled, one with spaces double the breadth of the spaces of the other. See above, p. 410.

2. Invading antipoints.—In this experiment a shutter is arranged behind the objective, which, by turning the handle on the base-board, can be gradually introduced into the tube of the instrument. It is to be noted that the advancing shutter destroys the resolution of the image by cutting down the eccentric beams, so that its effect is produced upon the centre of the field before the edge of the shutter itself appears in the instrument. See above, pp. 411 to 413.

3. Oscillating screen; electrically actuated. Designed and exhibited by Mr. E. Russell Clarke.—In this experiment the oscillating screen is driven electrically at a very high speed ranging, according to the number of oscillations in the electrical supply, at somewhere about 80 excursions a second. Note in this case the entire absence of any visible trace of the screen due to the high speed of vibration. Note further that the high speed makes for the steadiness of the instrument as the oscillation is too rapid to be sensibly communicated to the tube. In order to secure this freedom from vibration the mounting in which the screen oscillates is made heavy so as to take up its vibrations, and is supported by means of rubber washers upon the Microscope frame. See above, p. 420.

3A. Oscillating lamp filament.—The Microscope in Experiment No. 3 is illuminated by an electric lamp whose filament is fixed on the screen. The filament is caused to vibrate at a high periodicity, thereby producing a brilliant surface of focal light, instead of a straight line.

4. Oscillating screen driven by a spring motor for visual demonstration.—In this experiment the speed of the oscillating screen is comparatively low—about three excursions a second. The object exhibited is *P. ang.* magnified about 8000 diameters. Side by side with this Microscope there is arranged a twin instrument having exactly the same optical arrangements, except that it is not provided with a screen, giving the same magnifying power therefore, and exhibiting the same diatom. Note the imperfect definition of the aerial image and the number of intrusive spots, and compare with it the clean appearance and sharp definition of the screen image.

5. Oscillating screen for photographic use.—In this experiment the compounding draw-tube takes the place of the optical bench, and a magnification of about 400 diameters is obtained direct, and the negative so formed will usually bear enlargement four or five times in printing.

The specimens exhibited this evening have been produced in this instrument. Note the slow speed of oscillation—not more than about seven excursions a minute.

6. Illumination of the stage.—In this experiment a shutter is mounted with two apertures, one of which allows the whole stage to be flooded with light; the other cuts off the light except from the centre of the stage which is actually under observation. Note the strengthening of the image which results from substituting the small aperture for the large one. See above, p. 425.

---

#### EXPLANATION OF PLATE VI.

Fig. 98 (*see text*, p. 415).

Figs. I., II., and III. THE BACILLUS OF ANTHRAX, magnified  $400 \times 2\frac{1}{2} = 1000$  times.

Fig. I. The specimen photographed through an oscillating screen.

Fig. II. The image seen upon the screen at rest (showing grain of the screen).

Fig. III. The same object seen in the same instrument without the screen.

The apparatus used in the production of these photographs was a compounding draw-tube as described (p. 421), fitted with  $\frac{1}{14}$  oil-immersion by Beck as the principal objective, with a  $\frac{3}{8}$ -in. by the same makers as the second objective. These objectives were not selected on any principle of special adaptation to co-operative working, and in fact it will be seen how little adapted they are to work together from the flare spot in Fig. III.

Fig. III. shows the "peculiarly spotty appearance of the field under excessive magnification," to which Helmholtz refers (*see* p. 401). With an oscillating screen this apparatus gives a very pleasing image to the eye with amplifications amounting to as much as 8000 diameters.

Fig. 98.



*a*

*b*

*c*

*d*

II

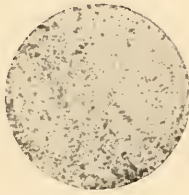

I

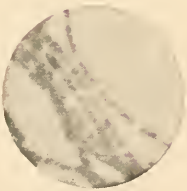

III

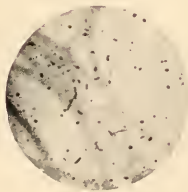





VII.—*On the Theory of Optical Images, with Special Reference to the Microscope.*

By LORD RAYLEIGH.\*

(Reprinted by permission from the *Philosophical Magazine*, August 1896.)

THE special subject of this paper has been treated from two distinct points of view. In the work of Helmholtz † the method followed is analogous to that which had long been used in the theory of the telescope. It consists in tracing the image representative of a mathematical point in the object, the point being regarded as self-luminous. The limit to definition depends upon the fact that owing to diffraction the image thrown even by a perfect lens is not confined to a point, but distends itself over a patch or disk of light of finite diameter. Two points in the object can appear fully separated only when the representative disks are nearly clear of one another. The application to the microscope was traced by means of a somewhat extended form of Lagrange's general optical theorem, and the conclusion was reached that the smallest resolvable distance  $\epsilon$  is given by

$$\epsilon = \frac{1}{2} \lambda / \sin a, \quad . \quad . \quad . \quad . \quad . \quad (1)$$

$\lambda$  being the wave-length in the medium where the object is situated, and  $a$  the divergence-angle of the extreme ray (the semi-angular aperture) in the same medium. If  $\lambda_0$  be the wave-length in vacuum,

$$\lambda = \lambda_0 / \mu, \quad . \quad . \quad . \quad . \quad . \quad (2)$$

$\mu$  being the refractive index of the medium; and thus

$$\epsilon = \frac{1}{2} \lambda_0 / \mu \sin a. \quad . \quad . \quad . \quad . \quad (3)$$

The denominator  $\mu \sin a$  is the quantity now well known (after Abbe) as the "numerical aperture."

The extreme value possible for  $a$  is a right angle, so that for the microscopic limit we have

$$\epsilon = \frac{1}{2} \lambda_0 / \mu. \quad . \quad . \quad . \quad . \quad (4)$$

\* The discussion of some further questions, now communicated to the Society, depends upon principles laid down in this paper, which, though published several years ago, does not seem to have attracted the attention of microscopists. It is thought that its republication in connection with the new investigations will be convenient to the reader.

† Pogg. Ann., Jubelband, 1874.

The limit can be depressed only by a diminution in  $\lambda_0$ , such as photography makes possible, or by an increase in  $\mu$ , the refractive index of the medium in which the object is situated.

This method, in which the object is considered point by point, seems the most straight-forward, and to a great extent it solves the problem without more ado. When the representative disks are thoroughly clear of one another, the two points in which they originate are resolved, and on the other hand, when the disks overlap the points are not distinctly separated. Open questions can relate only to intermediate cases of partial overlapping and various degrees of resolution. In these cases (as has been insisted upon by Dr. Stoney) we have to consider the relative phases of the overlapping lights before we can arrive at a complete conclusion.

If the various points of the object are self-luminous, there is no permanent phase-relation between the lights of the overlapping disks, and the resultant illumination is arrived at by simple addition of separate intensities. This is the situation of affairs in the ordinary use of a telescope, whether the object be a double star, the disk of the sun, the disk of the moon, or a terrestrial body. The distribution of light in the image of a double point, or of a double line, was especially considered in a former paper,\* and we shall turn to the subject later.

When, as sometimes happens in the use of the telescope, and more frequently in the use of the microscope, the overlapping lights have permanent phase-relations, these intermediate cases require a further treatment; and this is a matter of some importance as involving the behaviour of the instrument in respect to the finest detail which it is capable of rendering. We shall see that the image of a double point under various conditions can be delineated without difficulty.

In the earliest paper by Prof. Abbe † which somewhat preceded that of Helmholtz, similar conclusions were reached; but the demonstrations were deferred, and, indeed, they do not appear ever to have been set forth in a systematic manner. Although some of the positions then taken up, as for example that the larger features and the finer structure of a microscopic object are delineated by different processes, have since had to be abandoned, ‡ the publication of this paper marks a great advance, and has contributed powerfully to the modern development of the microscope. §

\* 'Investigations in Optics, with special reference to the Spectroscope,' *Phil. Mag.*, vol. viii. p. 266 (1879). † *Arch. f. Mikr. Anat.*, vol. ix. p. 413 (1873).

‡ Dallinger's edition of Carpenter's 'Microscope,' p. 64, 1891.

§ It would seem that the present subject, like many others, has suffered from over specialisation, much that is familiar to the microscopist being almost unknown to physicists, and *vice versa*. For myself I must confess that it is only recently, in consequence of a discussion between Mr. L. Wright and Dr. G. J. Stoney in the 'English Mechanic' (Sept., Oct., Nov., 1894; Nov. 8, Dec. 13, 1895; Jan. 17, 1896), that I have become acquainted with the distinguishing features of Prof. Abbe's work, and have learned that it was conducted upon different lines to that of Helmholtz. I am also indebted to Dr. Stoney for a demonstration of some of Abbe's experiments.

In Prof. Abbe's method of treating the matter the typical object is not a luminous *point*, but a *grating* illuminated by plane waves. Thence arise the well-known diffraction spectra, which are focussed near the back of the object-glass in its principal focal plane. If the light be homogeneous, the spectra are reduced to points, and the final image may be regarded as due to the simultaneous action of these points acting as secondary centres of light. It is argued that the complete representation of the object requires the co-operation of all the spectra. When only a few are present, the representation is imperfect; and when there is only one—for this purpose the central image counts as a spectrum—the representation wholly fails.

That this point of view offers great advantages, at least when the object under consideration is really a grating, is at once evident. More especially is this the case in respect of the question of the limit of resolution. It is certain that if one spectrum only be

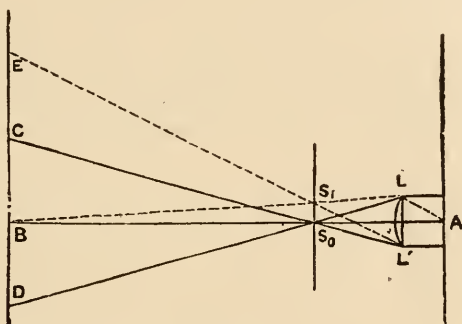

FIG. 117.

operative, the image must consist of a uniform field of light, and that no sign can appear of the real periodic structure of the object. From this consideration the resolving-power is readily deduced, and it may be convenient to recapitulate the argument for the case of perpendicular incidence. In fig. 117 AB represents the axis, A being in the plane of the object (grating) and B in the plane of the image. The various diffraction spectra are focussed by the lens LL' in the principal focal plane,  $S_0$  representing the central image due to rays which issue normally from the grating. After passing  $S_0$  the rays diverge in a cone corresponding to the aperture of the lens and illuminate a circle CD in the plane of the image, whose centre is B. The first lateral spectrum  $S_1$  is formed by rays diffracted from the grating at a certain angle; and in the critical case the region of the image illuminated by the rays diverging from  $S_1$  just includes B. The extreme ray  $S_1B$  evidently proceeds from A, which is the image of B. The condition for

the co-operation at B of the first lateral spectrum is thus that the angle of diffraction do not exceed the semi-angular aperture  $a$ . By elementary theory we know that the sine of the angle of diffraction is  $\lambda/\epsilon$ , so that the action of the lateral spectrum requires that  $\epsilon$  exceed  $\lambda/\sin a$ . If we allow the incidence upon the grating to be oblique, the limit becomes  $\frac{1}{2}\lambda/\sin a$ , as in (1).

We have seen that if one spectrum only illuminate B, the field shows no structure. If two spectra illuminate it with equal intensities, the field is occupied by ordinary interference bands, exactly as in the well known experiments of Fresnel. And it is important to remark that the character of these bands is always the same, both as respects the graduation of light and shade, and in the fact that they have no focus. When more than two spectra co-operate, the resulting interference phenomena are more complicated, and there is opportunity for a completer representation of the special features of the original grating.\*

While it is certain that the image ultimately formed may be considered to be due to the spectra focussed at  $S_0, S_1 \dots$ , the degree of conformity of the image to the original object is another question. From some of the expositions that have been given it might be inferred that if all the spectra emitted from the grating were utilised, the image would be a complete representation of the original. By considering the case of a very fine grating, which might afford no lateral spectra at all, it is easy to see that this conclusion is incorrect, but the matter stands in need of further elucidation. Again, it is not quite clear at what point the utilisation of a spectrum really begins. All the spectra which the grating is competent to furnish are focussed in the plane  $S_0 S_1$ ; and some of them might be supposed to operate partially even although the part of the image under examination is outside the geometrical cone defined by the aperture of the object-glass. For these and other reasons it will be seen that the spectrum theory,†

\* These effects were strikingly illustrated in some observations upon gratings with 6000 lines to the inch, set up vertically in a dark room and illuminated by sunlight from a distinct vertical slit. The object-glass of the Microscope was a quarter inch. When the original grating, divided upon glass (by Nobert), was examined in this way, the lines were well seen if the instrument was in focus, but, as usual, a comparatively slight disturbance of focus caused all structure to disappear. When, however, a photographic copy of the same glass original, made with bitumen, was substituted for it, very different effects ensued. The structure could be seen even although the object-glass were drawn back through  $1\frac{1}{2}$  in. from its focussed position; and the visible lines were twice as close, as if at the rate of 12,000 to the inch. The difference between the two cases is easily explained upon Abbe's theory. A soda flame viewed through the original showed a strong central image (spectrum of zero order) and comparatively faint spectra of the first and higher orders. A similar examination of the copy revealed very brilliant spectra of the first order on both sides, and a relatively feeble central image. The case is thus approximately the same as when in Abbe's experiment all spectra except the first (on the two sides) are blocked out.

† The special theory initiated by Prof. Abbe is usually called the "diffraction theory," a nomenclature against which it is necessary to protest. Whatever may be

valuable as it is, needs a good deal of supplementing, even when the representation of a grating under parallel light is in question.

When the object under examination is not a grating or a structure in which the pattern is repeated an indefinite number of times, but for example a double point, and when the incident light is not parallel, the spectrum theory, as hitherto developed, is inapplicable. As an extreme example of the latter case we may imagine the grating to be self-illuminous. It is obvious that the problem thus presented must be within the scope of any complete theory, and equally so that here there are no spectra formed, as these require the radiations from the different elements of the grating to possess permanent phase-relations. It appears, therefore, to be a desideratum that the matter should be reconsidered from the older point of view, according to which the typical object is a point and not a grating. Such a treatment illustrates the important principle that the theory of resolving-power is essentially the same for all instruments. The peculiarities of the microscope arise from the fact that the divergence-angles are not limited to be small, and from the different character of the illumination usually employed; but, theoretically considered, these are differences of detail. The investigation can, without much difficulty, be extended to gratings, and the results so obtained confirm for the most part the conclusions of the spectrum theory.

It will be convenient to commence our discussion by a simple investigation of the resolving-power of an optical instrument for a self-luminous double point, such as will be applicable equally to the telescope and to the microscope. In fig. 118 AB represents the axis, A being a point of the object and B a point of the image. By the operation of the object-glass LL' all the rays issuing from A arrive in the same phase at B. Thus if A be self-luminous, the illumination is a maximum at B, where all the secondary waves agree in phase. B is in fact the centre of the diffraction disk which constitutes the image of A. At neighbouring points the illumination is less, in consequence of the discrepancies of phase which there enter. In like manner, if we take a neighbouring point P in the plane of the object, the waves which issue from it will arrive at B with phases no longer absolutely accordant, and the discrepancy of phase will increase as the interval AP increases. When the interval is very small, the discrepancy of phase, though mathematically existent, produces no practical effect, and the illumination at B due to P is as important as that due to A, the

the view taken, any theory of resolving power of optical instruments must be a diffraction theory in a certain sense, so that the name is not distinctive. Diffraction is more naturally regarded as the obstacle to fine definition, and not, as with some exponents of Prof. Abbe's theory, the machinery by which good definition is brought about.

intensities of the two luminous centres being supposed equal. Under these conditions it is clear that A and P are not separated in the image. The question is, to what amount must the distance AP be increased in order that the difference of situation may make itself felt in the image. This is necessarily a question of degree; but it does not require detailed calculations in order to show that the discrepancy first becomes conspicuous when the phases corresponding to the various secondary waves which travel from P to B range over about a complete period. The illumination at B due to P then becomes comparatively small, indeed for some forms of aperture evanescent. The extreme discrepancy is that between the

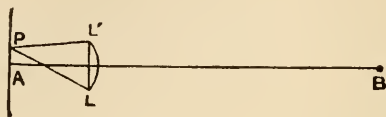

FIG. 118.

waves which travel through the outermost parts of the object-glass at L and L'; so that, if we adopt the above standard of resolution, the question is, where must P be situated in order that the relative retardation of the rays PL and PL' may on their arrival at B amount to a wave-length ( $\lambda$ ). In virtue of the general law that the reduced optical path is stationary in value, this retardation may be calculated without allowance for the different paths pursued on the further side of L, L', so that its value is simply PL - PL'. Now since AP is very small, AL' - PL' is equal to AP . sin  $\alpha$ , where  $\alpha$  is the semi-angular aperture L'AB. In like manner PL - AL has the same value, so that

$$PL - PL' = 2 AP . \sin \alpha.$$

According to the standard adopted, the condition of resolution is therefore that AP, or  $\epsilon$ , should exceed  $\frac{1}{2}\lambda/\sin \alpha$ , as in (1). If  $\epsilon$  be less than this, the images overlap too much; while if  $\epsilon$  greatly exceed the above value the images become unnecessarily separated.

In the above argument the whole space between the object and the lens is supposed to be occupied by matter of one refractive index, and  $\lambda$  represents the wave-length *in this medium* of the kind of light employed. If the restriction as to uniformity be violated, what we have ultimately to do with is the wave-length in the medium immediately surrounding the object.

The statement of the law of resolving-power has been made in a form appropriate to the microscope, but it admits also of immediate application to the telescope. If  $2R$  be the diameter of

the object-glass, and  $D$  the distance of the object, the angle subtended by  $AP$  is  $\epsilon/D$ , and the angular resolving-power is given by

$$\frac{\lambda}{2 D \sin \alpha} = \frac{\lambda}{2 R}, \quad \cdot \quad \cdot \quad \cdot \quad \cdot \quad \cdot \quad (5)$$

the well-known formula.

This method of derivation makes it obvious that there is no essential difference of principle between the two cases, although the results are conveniently stated in different forms. In the case of the telescope we have to do with a linear measure of aperture and an angular limit of resolution, whereas in the case of the microscope the limit of resolution is linear and is expressed in terms of angular aperture.

In the above discussion it has been supposed for the sake of simplicity that the points to be discriminated are self-luminous, or at least behave as if they were such. It is of interest to inquire how far this condition can be satisfied when the object is seen by borrowed light. We may imagine that the object takes the form of an opaque screen, perforated at two points, and illuminated by distant sources situated behind.

If the source of light be reduced to a point, so that a single train of plane waves falls upon the screen, there is a permanent phase-relation between the waves incident at the two points, and therefore also between the waves scattered from them. In this case the two points are as far as possible from behaving as if they were self-luminous. If the incidence be perpendicular, the secondary waves issue in the same phase; but in the case of obliquity there is a permanent phase-difference. This difference, measured in wave-lengths, increases up to  $\epsilon$ , the distance between the points, the limit being attained as the incidence becomes grazing.

When the light originates in distant independent sources, not limited to a point, there is no longer an absolutely definite phase-relationship between the secondary radiations from the two apertures; but this condition of things may be practically maintained, if the angular magnitude of the source be not too large. For example, if the source be limited to an angle  $\theta$  round the normal to the screen, the maximum phase-difference measured in wave-lengths is  $\epsilon \sin \theta$ , so that if  $\sin \theta$  be a small fraction of  $\lambda/\epsilon$ , the finiteness of  $\theta$  has but little effect. When, however,  $\sin \theta$  is so great that  $\epsilon \sin \theta$  becomes a considerable multiple of  $\lambda$ , the secondary radiations become approximately independent, and the apertures behave like self-luminous points. It is evident that even with a complete hemispherical illumination this condition can scarcely be attained when  $\epsilon$  is less than  $\lambda$ .

The use of a condenser allows the widely-extended source to be

dispensed with. By this means an image of a distant source composed of independently radiating parts, such as a lamp-flame, may be thrown upon the object, and it might at first sight be supposed that the problem under consideration was thus completely solved in all cases, inasmuch as the two apertures correspond to different parts of the flame. But we have to remember here and everywhere that optical images are not perfect, and that to a point of the flame corresponds in the image, not a point, but a disk of finite magnitude. When this consideration is taken into account, the same limitation as before is encountered.

For what is the smallest disk into which the condenser is capable of concentrating the light received from a distant point? Fig. 118 and the former argument apply almost without modification, and they show that the radius AP of the disk has the value  $\frac{1}{2}\lambda / \sin a$ , where  $a$  is the semi-angular aperture of the condenser. Accordingly the diameter of the disk cannot be reduced below  $\lambda$ ; and if  $\epsilon$  be less than  $\lambda$  the radiations from the two apertures are only partially independent of one another.

It seems fair to conclude that the function of the condenser in microscopic practice is to cause the object to behave, at any rate in some degree, as if it were self-luminous, and thus to obviate the sharply-marked interference-bands which arise when permanent and definite phase-relations are permitted to exist between the radiations which issue from various points of the object.

As we shall have occasion later to employ Lagrange's theorem, it may be well to point out how an instantaneous proof of it may be given upon the principles [especially that the optical distance measured along a ray is a minimum] already applied. As before, A, B (fig. 119) represents the axis of the instrument, A and B being

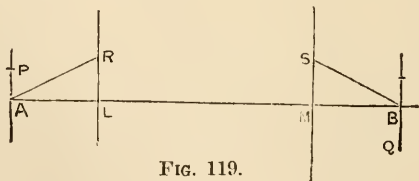

conjugate points. P is a point near A in the plane through A perpendicular to the axis, and Q is its image\* in the perpendicular plane through B. Since A and B are conjugate, the optical distance between them is the same for all [ray-]paths, *c.g.* for A R S B and A L M B. [For the same reason the optical distance from P to Q is the same along the various rays, one of which lies infinitely

\* [1902. In the original diagram Q was shown upon the wrong side of B. I owe the correction to a correspondence with Prof. Everett.]



near to P R S Q and another to P L M Q.] And, since A P, B Q are perpendicular to the axis, the optical distance from P to Q is the same (to the first order of small quantities) as from A to B. Consequently the optical distance P R S Q is the same as A R S B. Thus, if  $\mu, \mu'$  be the refractive indices in the neighbourhood of A and B respectively,  $\alpha$  and  $\beta$  the divergence-angles R A L, S B M for a given ray, we have

$$\mu \cdot A P \cdot \sin \alpha = \mu' \cdot B Q \cdot \sin \beta, \quad . \quad . \quad . \quad (6)$$

where A P, B Q denote the corresponding linear magnitudes of the two images. This is the theorem of Lagrange, extended by Helmholtz so as to apply to finite divergence-angles.\*

We now pass on to the actual calculation of the images to be expected upon Fresnel's principles in the various cases that may arise. The origin of co-ordinates ( $\xi = 0, \eta = 0$ ) in the focal plane is the geometrical image of the radiant point. If the vibration incident upon the lens be represented by  $\cos(2\pi V t / \lambda)$ , where V is the velocity of light, the vibration at any point  $\xi, \eta$  in the focal plane is †

$$- \frac{1}{\lambda f} \iint \sin \frac{2\pi}{\lambda} \left\{ V t - f + \frac{x\xi + y\eta}{f} \right\} dx dy, \quad . \quad (7)$$

in which  $f$  denotes the focal length, and the integration with respect to  $x$  and  $y$  is to be extended over the aperture of the lens. If for brevity we write

$$2\pi \xi / \lambda f = p, \quad 2\pi \eta / \lambda f = q, \quad . \quad . \quad . \quad (8)$$

(7) may be put into the form

$$- \frac{C}{\lambda f} \sin \frac{2\pi}{\lambda} (V t - f) - \frac{S}{\lambda f} \cos \frac{2\pi}{\lambda} (V t - f), \quad . \quad (9)$$

where

$$S = \iint \sin (px + qy) dx dy, \quad . \quad . \quad . \quad (10)$$

$$C = \iint \cos (px + qy) dx dy. \quad . \quad . \quad . \quad (11)$$

It will suffice for our present purpose to limit ourselves to the case where the aperture is symmetrical with respect to  $x$  and  $y$ . We have then  $S = 0$ , and

$$C = \iint \cos px \cos qy dx dy, \quad . \quad . \quad . \quad (12)$$

the phase of the vibration being the same at all points of the diffraction pattern.

\* I learn from Czapski's excellent 'Theorie der Optischen Instrumente' that a similar derivation of Lagrange's theorem from the principle of minimum path had already been given many years ago by Hockin (Micros. Soc. Journ., vol. iv. p. 337, 1884).  
 † See, for example, Enc. Brit., 'Wave Theory,' p. 430 (1878).

When the aperture is rectangular, of width  $a$  parallel to  $x$ , and of width  $b$  parallel to  $y$ , the limits of integration are from  $-\frac{1}{2}a$  to  $+\frac{1}{2}a$  for  $x$ , and from  $-\frac{1}{2}b$  to  $+\frac{1}{2}b$  for  $y$ . Thus

$$C = ab \frac{\sin(\pi \xi a / \lambda f)}{\pi \xi a / \lambda f} \frac{\sin(\pi \eta b / \lambda f)}{\pi \eta b / \lambda f}, \quad (13)$$

and by (9) the amplitude of vibration (irrespective of sign) is  $C/\lambda f$ . This expression gives the diffraction pattern due to a single point of the object whose geometrical image is at  $\xi = 0, \eta = 0$ . Sometimes, as in the application to a grating, we wish to consider the image due to a uniformly luminous *line*, parallel to  $\eta$ , and this can always be derived from integration from the expression applicable to a point. But there is a distinction to be observed according as the radiations from the various parts of the line are independent or are subject to a fixed phase-relation. In the former case we have to deal only with the *intensity*, represented by  $I^2$  or  $C^2/\lambda^2 f^2$ ; and we get

$$\int_{-\infty}^{+\infty} I^2 d\eta = \frac{a^2 b}{\lambda f} \frac{\sin^2(\pi \xi a / \lambda f)}{(\pi \xi a / \lambda f)^2} \quad (14)$$

by means of the known integral

$$\int_{-\infty}^{+\infty} \frac{\sin^2 x}{x^2} dx = \int_{-\infty}^{+\infty} \frac{\sin x}{x} dx = \pi. \quad (15)$$

This gives, as a function of  $\xi$ , the intensity due to a self-luminous line whose geometrical image coincides with  $\xi = 0$ .

Under the second head of a fixed phase-relation we need only consider the case where the radiations from the various parts of the line start in the *same* phase. We get, almost as before,

$$\frac{1}{\lambda f} \int_{-\infty}^{+\infty} C d\eta = a \frac{\sin(\pi \xi a / \lambda f)}{\pi \xi a / \lambda f} \quad (16)$$

for the expression of the resultant amplitude corresponding to  $\xi$ .

In order to make use of these results we require a table of the values of  $\sin u/u$ , and of  $\sin^2 u/u^2$ . The following (Table I.) will suffice for our purposes.

When we have to deal with a single point or single line only, this table gives directly the distribution of light in the image,  $u$  being equated to  $\pi \xi a / \lambda f$ . The illumination first vanishes when  $u = \pi$ , or  $\xi/f = \lambda/a$ .

On a former occasion\* it has been shown that a self-luminous point or line at  $u = -\pi$  is barely separated from one at  $u = 0$ . It will be of interest to consider this case under three different conditions as to phase-relationship; (i) when the phases are the

\* Phil. Mag., vol. viii. p. 266, 1879.

TABLE I.

$\frac{4u}{\pi}$	$\frac{\sin u}{u}$	$\frac{\sin^2 u}{u^2}$	$\frac{4u}{\pi}$	$\frac{\sin u}{u}$	$\frac{\sin^2 u}{u^2}$
0	+ 1.0000	1.0000	9	+ .1000	.0100
1	.9003	.8105	10	.1273	.0162
2	.6366	.4053	11	.0818	.0067
3	.3001	.0901	12	.0000	.0000
4	.0000	.0000	13	- .0692	.0048
5	- .1801	.0324	14	- .0909	.0083
6	- .2122	.0450	15	- .0600	.0036
7	- .1286	.0165	16	.0000	.0000
8	.0000	.0000			

same, as will happen when the illumination is by plane waves incident perpendicularly; (ii.) when the phases are opposite; and (iii.) when the phase-difference is a quarter period, which gives the same result for the intensity as if the apertures were self-luminous. The annexed table gives the numerical values required.

TABLE II.

$\frac{4u}{\pi}$	$\frac{\sin u}{u}$ + $\frac{\sin(u + \pi)}{u + \pi}$	$\frac{\sin u}{u}$ - $\frac{\sin(u + \pi)}{u + \pi}$	$\sqrt{\frac{\sin^2 u}{u^2}}$ + $\frac{\sin^2(u + \pi)}{(u + \pi)^2}$
- 4	+ 1.0000	- 1.0000	+ 1.000
- 3	+ 1.2004	- .6002	+ .949
- 2	+ 1.2732	.0000	+ .900
- 1	+ 1.2004	+ .6002	+ .949
0	+ 1.0000	+ 1.0000	+ 1.000
1	+ .7202	+ 1.0804	+ .918
2	+ .4244	+ .8488	+ .671
3	+ .1715	+ .4287	+ .326
4	.0000	.0000	.000
5	- .0800	- .2801	- .206
6	- .0849	- .3395	- .247
7	- .0468	- .2105	- .152
8	.0000	.0000	.000
9	+ .0308	+ .1693	+ .122
10	+ .0364	+ .2183	+ .156
11	+ .0218	+ .1419	+ .101
12	.0000	.0000	.000

In cases (i.) and (iii.) the resultant amplitude is symmetrical with respect to the point  $u = -\frac{1}{2}\pi$  midway between the two geometrical images; in case (ii.) the sign is reversed, but this of course has no effect upon the intensity. Graphs of the three functions are given in fig. 120, the geometrical images being at the points marked  $-\pi$  and  $0$ . It will be seen that while in case iii., relating to self-luminous points or lines, there is an approach to separation, nothing but an accurate comparison with the curve due to a single source would reveal the duplicity in case i. On the

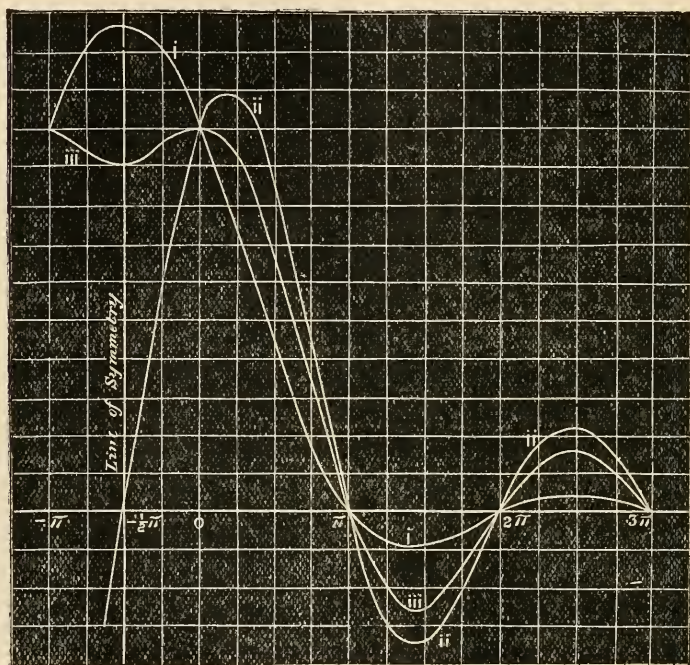

FIG. 120.

other hand, in case ii., where there is a phase-difference of half a period between the radiations, the separation may be regarded as complete.

In a certain sense the last conclusion remains undisturbed even when the double point is still closer, and also when the aperture is of any other symmetrical form, e.g. circular. For at the point of symmetry in the image, midway between the two geometrical images of the radiant points, the component amplitudes are necessarily equal in numerical value and opposite in sign, so that the resultant amplitude or illumination vanishes. For example, sup-

pose that the aperture is rectangular and that the points or lines are twice as close as before, the geometrical images being situated at  $u = -\frac{1}{2}\pi$ ,  $u = 0$ . The resultant amplitude is represented by  $f(u)$ , where

$$f(u) = \frac{\sin u}{u} - \frac{\sin(u + \frac{1}{2}\pi)}{u + \frac{1}{2}\pi}. \quad . \quad . \quad (17)$$

The values of  $f(u)$  are given in Table III. They show that the resultant vanishes at the place of symmetry  $u = -\frac{1}{4}\pi$ , and rises to a maximum at a point near  $u = \frac{1}{2}\pi$ , considerably beyond the geometrical image at  $u = 0$ . Moreover, the value of the maximum itself is much less than before, a feature which would become

TABLE III.

$\frac{4u}{\pi}$	$f(u)$	$\frac{4u}{\pi}$	$f(u)$
- 1	+ .00	5	- .05
0	+ .36	6	- .21
1	+ .60	7	- .23
2	+ .64	8	- .13
3	+ .48	9	+ .02
4	+ .21		

more and more pronounced as the points were taken closer. At this stage the image becomes only a very incomplete representation of the object; but if the formation of a black line in the centre of the pattern be supposed to constitute resolution, then resolution occurs at all degrees of closeness.\* We shall see later,

\* These results are easily illustrated experimentally. I have used two parallel slits, formed in films of tin-foil or of chemically deposited silver, of which one is conveniently made longer than the other. These slits are held vertically and are viewed through a small telescope, provided with a high-power eye-piece, whose horizontal aperture is restricted to a small width. The distance may first be so chosen that when backed by a neighbouring flame the double part of the slit just manifests its character by a faint shadow along the centre. If the flame is replaced by sunlight shining through a distant vertical slit, the effect depends upon the precise adjustment. When everything is in line the image is at its brightest, but there is now no sign of resolution of the double part of the slit. A very slight sideways displacement, in my case effected most conveniently by moving the telescope, brings in the half-period retardation, showing itself by a black bar down the centre. An increased displacement, leading to a relative retardation of three halves of a period, gives much the same result, complicated, however, by chromatic effects.

In conformity with theory, the black bar down the image of the double slit may still be observed when the distance is increased much beyond that at which duplicity disappears under flame illumination.

For these experiments I chose the telescope, not only on account of the greater facility of manipulation which it allows, but also in order to make it clear that the theory is general, and that such effects are not limited, as is sometimes supposed, to the case of the microscope.

from calculations conducted by the same method, that a grating of an equal degree of closeness would show no structure at all but would present a uniformly illuminated field.

But before proceeding to such calculations we may deduce by Lagrange's theorem the interval  $\epsilon$  in the original object corresponding to that between  $u = 0$  and  $u = \pi$  in the image, and thence effect a comparison with a grating by means of Abbe's theory. The linear dimensions ( $\xi$ ) of the image corresponding to  $u = \pi$  is given by  $\xi = \lambda f/a$ ; and from Lagrange's theorem

$$\epsilon/\xi = \sin \beta/\sin a, \quad . \quad . \quad . \quad (17a)$$

in which  $a$  is the "semi-angular aperture," and  $\beta = a/2f$ . Thus corresponding to  $u = \pi$ ,

$$\epsilon = \frac{1}{2}\lambda/\sin a.$$

The case of a double point or line represented in fig. 4 lies therefore at the extreme limit of resolution for a grating in which the period is the interval between the double points. And if the incidence of the light upon the grating were limited to be perpendicular, the period would have to be doubled before the grating could show any structure.

When the aperture is circular, of radius  $R$ , the diffraction pattern is symmetrical about the geometrical image ( $p = 0, q = 0$ ), and it suffices to consider points situated upon the axis of  $\xi$  for which  $\eta$  (and  $q$ ) vanish. Thus from (12)

$$C = \iint \cos px \, dx \, dy = 2 \int_{-R}^{+R} \cos px \sqrt{R^2 - x^2} \, dx. \quad (18)$$

This integral is the Bessel function of order unity, definable by

$$J_1(z) = \frac{z}{\pi} \int_0^\pi \cos(z \cos \phi) \sin^2 \phi \, d\phi. \quad . \quad . \quad (19)$$

Thus, if  $x = R \cos \phi$ ,

$$C = \pi R^2 \frac{2 J_1(p R)}{p R}, \quad . \quad . \quad . \quad (20)$$

or, if we write  $u = \pi \xi \cdot 2 R/\lambda f$ ,

$$C = \pi R^2 \frac{2 J_1(u)}{u}. \quad . \quad . \quad . \quad (21)^*$$

This notation agrees with that employed for the rectangular aperture if we consider that  $2 R$  corresponds with  $a$ .

\* Enc. Brit., 'Wave Theory,' p. 432.

The illumination at various parts of the image of a double point may be investigated as before, especially if we limit ourselves to points which lie upon the line joining the two geometrical images. The only difference in the calculations is that represented by the substitution of  $2 J_1$  for sine. We shall not, however, occupy space by tables and drawings such as have been given for a rectangular aperture. It may suffice to consider the three principal points in the image due to a double source whose geometrical images are situated at  $u = 0$  and  $u = -\pi$ , these being the points just mentioned and that midway between them at  $u = -\frac{1}{2}\pi$ . The values of the functions required are

$$\begin{aligned} 2 J_1(0)/0 &= 1.0000 = \sqrt{\{1.0000\}}. \\ 2 J_1(\pi)/\pi &= .1812 = \sqrt{\{.03283\}}. \\ 2 J_1(\frac{1}{2}\pi)/\frac{1}{2}\pi &= .7217 = \sqrt{\{.5209\}}. \end{aligned}$$

In the case (corresponding to i. fig. 4) where there is similarity of phase, we have at the geometrical images amplitudes 1.1812 as against 1.4434 at the point midway between. When there is opposition of phase the first becomes  $\pm .8188$ , and the last zero.\* When the phases differ by a quarter period, or when the sources are self-luminous (iii. fig. 4), the amplitudes at the geometrical images are  $\sqrt{\{1.0328\}}$  or 1.0163, and at the middle point  $\sqrt{\{1.0418\}}$  or 1.0207. The partial separation, indicated by the central depression in curve iii. fig. 4, is thus lost when the rectangular aperture is exchanged for a circular one of equal width. It should be borne in mind that these results do not apply to a double *line*, which in the case of a circular aperture behaves differently from a double *point*.

There is one respect in which the theory is deficient, and the deficiency is the more important the larger the angular aperture. The formula (7) from which we start assumes that a radiant point radiates equally in all directions, or at least that the radiation from it after leaving the object-glass is equally dense over the whole area of the section. In the case of telescopes, and microscopes of moderate angular aperture, this assumption can lead to no appreciable error; but it may be otherwise when the angular aperture is very large. The radiation from an ideal centre of transverse vibrations is certainly not uniform in various directions, and indeed vanishes in that of primary vibration. If we suppose such an ideal source to be situated upon the axis of a wide-angled object-glass, we might expect the diffraction pattern to be less closely limited in that axial plane which includes the direction of primary vibration than in that which is perpendicular to it. The result for a double point illuminated by borrowed light would be a better degree of separation when the primary vibrations are

\* The zero illumination extends to all points upon the line of symmetry.

perpendicular to the line of junction than when they are parallel to it.

Although it is true that complications and uncertainties under this head are not without influence upon the theory of the microscopic limit, it is not to be supposed that any considerable variation from that laid down by Abbe and Helmholtz is admissible. Indeed, in the case of a grating the theory of Abbe is still adequate, so far as the limit of resolution is concerned; for, as Dr. Stoney has remarked, the irregularity of radiation in different directions tells only upon the relative brightness and not upon the angular position of the spectra. And it will remain true that there can be no resolution without the co-operation of two spectra at least.

In Table II. and fig. 120 we have considered the image of a double point or line as formed by a lens of rectangular aperture. It is now proposed to extend the calculation to the case where the series of points or lines is infinite, constituting a *row* of points or a *grating*. The intervals are supposed to be strictly equal, and also the luminous intensities. When the aperture is rectangular, the calculation is the same whether we are dealing with a row of points or with a grating, but we have to distinguish according as various centres radiate independently, viz. as if they were self-luminous, or are connected by phase-relations. We will commence with the former case.

If the geometrical images of the various luminous points are situated at  $u = 0, u = \pm v, u = \pm 2v, \&c.$ , the expressions for the intensity at any point  $u$  of the field may be written as an infinite series,

$$I(u) = \frac{\sin^2 u}{u^2} + \frac{\sin^2(u+v)}{(u+v)^2} + \frac{\sin^2(u-v)}{(u-v)^2} \\ + \frac{\sin^2(u+2v)}{(u+2v)^2} + \frac{\sin^2(u-2v)}{(u-2v)^2} + \dots \quad (22)$$

Being an even function of  $u$  and periodic in period  $v$ , (22) may be expanded by Fourier's theorem in a series of cosines. Thus

$$I(u) = I_0 + I_1 \cos \frac{2\pi u}{v} + \dots + I_r \cos \frac{2\pi r u}{v} + \dots; \quad (23)$$

and the character of the field of light will be determined when the values of the constants  $I_0, I_1, \&c.$ , are known. For these we have as usual

$$I_0 = \frac{1}{v} \int_0^v I(u) du, \quad I_r = \frac{2}{v} \int_0^v I(u) \cos \frac{2\pi r u}{v} du; \quad (24)$$

and it only remains to effect the integrations. To this end we may observe that each term in the series (22) must in reality make



an equal contribution to  $I_r$ . It will come to the same thing whether, as indicated in (24), we integrate the sum of the series from 0 to  $v$ , or integrate a single term of it, e.g. the first, from  $-\infty$  to  $+\infty$ . We may therefore take

$$I_0 = \frac{1}{v} \int_{-\infty}^{+\infty} \frac{\sin^2 u}{u^2} du = \frac{\pi}{v}; \quad . . . \quad (25)$$

$$I_r = \frac{2}{v} \int_{-\infty}^{+\infty} \frac{\sin^2 u}{u^2} \cos \frac{2\pi r u}{v} du. \quad . . . \quad (26)$$

To evaluate (26) we have

$$\int_{-\infty}^{+\infty} \frac{\sin^2 u \cos su}{u^2} du = \int_{-\infty}^{+\infty} \frac{1}{u} \frac{d}{du} (\sin^2 u \cos su) du,$$

and

$$\begin{aligned} \frac{d}{du} (\sin^2 u \cos su) &= -\frac{s}{2} \sin 2u \\ &+ \frac{2+s}{4} \sin(2+s)u + \frac{2-s}{4} \sin(2-s)u; \end{aligned}$$

so that by (15) ( $s$  being positive)

$$\int_{-\infty}^{+\infty} \frac{\sin^2 u \cos su}{u^2} du = \pi \left\{ -\frac{s}{2} + \frac{2+s}{4} \pm \frac{2-s}{4} \right\},$$

the *minus* sign being taken when  $2-s$  is negative.

Hence

$$I_r = \frac{2\pi}{v} \left( 1 - \frac{\pi r}{v} \right), \quad \text{or } 0, \quad . . . \quad (27)$$

according as  $r$  exceeds or falls short of  $r\pi$ .

We may now trace the effect of altering the value of  $v$ . When  $v$  is large, a considerable number of terms in the Fourier expansion (23) are of importance, and the discontinuous character of the luminous grating or row of points is fairly well represented in the image. As  $v$  diminishes, the higher terms drop out in succession, until when  $v$  falls below  $2\pi$  only  $I_0$  and  $I_1$  remain. From this point onwards  $I_1$  continues to diminish until it also finally disappears when  $v$  drops below  $\pi$ . The field is then uniformly illuminated, showing no trace of the original structure. The case  $v = \pi$  is that of fig. 120, and curve iii. shows that at a stage when an infinite series shows no structure, a *pair* of luminous points or lines of the same closeness are still in some degree separated. It will be remembered that  $v = \pi$  corresponds to  $\epsilon = \frac{1}{2} \lambda / \sin \alpha$ ,

$\epsilon$  being the linear period of the original object and  $a$  the semi-angular aperture.

We will now pass on to consider the case of a grating or row of points perforated in an opaque screen and illuminated by plane waves of light. If the incidence be oblique, the phase of the radiation emitted varies by equal steps as we pass from one element to the next. But for the sake of simplicity we will commence with the case of perpendicular incidence, where the radiations from the various elements all start in the same phase. We have now to superpose amplitudes, and not as before intensities. If  $A$  be the resultant amplitude, we may write

$$\begin{aligned} A(u) &= \frac{\sin u}{u} + \frac{\sin(u+v)}{u+v} + \frac{\sin(u-v)}{u-v} + \dots \\ &= A_0 + A_1 \cos \frac{2\pi u}{v} + \dots + A_r \cos \frac{2\pi r u}{v} + \dots \quad (28) \end{aligned}$$

When  $v$  is very small, the infinite series identifies itself more and more nearly with the integral

$$\frac{1}{v} \int_{-\infty}^{+\infty} \frac{\sin u}{u} du, \text{ viz. } \frac{\pi}{v}.$$

In general we have, as in the last problem,

$$A_0 = \frac{1}{v} \int_{-\infty}^{+\infty} \frac{\sin u}{u} du; \quad A_r = \frac{2}{v} \int_{-\infty}^{\infty} \frac{\sin u}{u} \cos \frac{2\pi r u}{v} du; \quad (29)$$

so that  $A_0 = \pi/v$ . As regards  $A_r$ , writing  $s$  for  $2\pi r/v$ , we have

$$A_r = \frac{1}{v} \int_{-\infty}^{+\infty} \frac{\sin(1+s)u + \sin(1-s)u}{u} du = \frac{\pi}{v} (1 \pm 1),$$

the lower sign applying when  $(1-s)$  is negative. Accordingly,

$$A_r(u) = \frac{\pi}{v} \left\{ 1 + 2 \cos \frac{2\pi u}{v} + 2 \cos \frac{4\pi u}{v} + \dots \right\} \quad (30)$$

the series being continued so long as  $2\pi r < v$ .

If the series (30) were continued *ad infinitum*, it would represent a discontinuous distribution, limited to the points (or lines)  $u = 0, u = \pm v, u = \pm 2v, \&c.$ , so that the image formed would accurately correspond to the original object. This condition of things is most nearly realised when  $v$  is very great, for then (30) includes a large number of terms. As  $v$  diminishes the higher terms drop out in succession, retaining however (in contrast with (27)) their full value up to the moment of disappearance. When  $v$  is less than  $2\pi$ , the series is reduced to its constant term, so

that the field becomes uniform. Under this kind of illumination, the resolving-power is only half as great as when the object is self-luminous.

These conclusions are in entire accordance with Abbe's theory. The first term of (30) represents the central image, the second term the *two* spectra of the first order, the third term the two spectra of the second order, and so on. Resolution fails at the moment when the spectra of the first order cease to co-operate, and we have already seen that this happens for the case of perpendicular incidence when  $v = 2\pi$ . The two spectra of any given order fail at the same moment.

If the series stops after the lateral spectra of the first order,

$$A(u) = \frac{\pi}{v} \left\{ 1 + 2 \cos \frac{2\pi u}{v} \right\}, \quad \dots \quad (31)$$

showing a maximum intensity when  $u = 0$ , or  $\frac{1}{2}v$ , and zero intensity when  $u = \frac{1}{3}v$ , or  $\frac{2}{3}v$ . These bands are not the simplest kind of interference bands. The latter require the operation of two spectra only; whereas in the present case there are three—the central image and the two spectra of the first order.

We may now proceed to consider the case when the incident plane waves are inclined to the grating. The only difference is that we require now to introduce a change of phase between the image due to each element and its neighbour. The series representing the resultant amplitude at any point  $u$  may still be written

$$\begin{aligned} \frac{\sin u}{u} + \frac{\sin(u+v)}{u+v} e^{-imv} + \frac{\sin(u-v)}{u-v} e^{+imv} \\ + \frac{\sin(u+2v)}{u+2v} e^{-2imv} + \dots \quad \dots \quad (32) \end{aligned}$$

For perpendicular incidence  $m = 0$ . If  $\gamma$  be the obliquity,  $\epsilon$  the grating-interval,  $\lambda$  the wave-length, [ $i = \sqrt{-1}$ ],

$$m\gamma / 2\pi = \epsilon \sin \gamma / \lambda. \quad \dots \quad (33)$$

The series (32), as it stands, is not periodic with respect to  $u$  in period  $v$ , but evidently it can differ from such a periodic series only by the factor  $e^{imv}$ .

The series

$$\begin{aligned} \frac{e^{-imu} \sin u}{u} + \frac{e^{-im(u+v)} \sin(u+v)}{u+v} \\ + \frac{e^{-im(u-v)} \sin(u-v)}{u-v} + \frac{e^{-im(u+2v)} \sin(u+2v)}{u+2v} + \dots \quad (34) \end{aligned}$$

is truly periodic, and may therefore be expanded by Fourier's theorem in periodic terms:

$$\begin{aligned} (34) &= A_0 + i B_0 + (A_1 + i B_1) \cos(2\pi u/v) \\ &\quad + (C_1 + i D_1) \sin(2\pi u/v) + \dots \\ &+ (A_r + i B_r) \cos(2r\pi u/v) + (C_r + i D_r) \sin(2r\pi u/v) + \dots \quad (35) \end{aligned}$$

As before, if  $s = 2r\pi/v$ ,

$$\frac{1}{2} v (A_r + i B_r) = \int_{-\infty}^{+\infty} \frac{e^{-imu} \sin u \cos su}{u} du;$$

so that  $B_r = 0$ , while

$$\frac{1}{2} v \cdot A_r = \int_{-\infty}^{+\infty} \frac{\cos mu \sin u \cos su}{u} du. \quad (36)$$

In like manner  $C_r = 0$ , while

$$-\frac{1}{2} v \cdot D_r = \int_{-\infty}^{+\infty} \frac{\sin mu \sin u \sin su}{u} du. \quad (37)$$

In the case of the zero suffix

$$B_0 = 0, \quad v A_0 = \int_{-\infty}^{+\infty} \frac{\cos mu \sin u}{u} du. \quad (38)$$

When the products of sines and cosines which occur in (36) &c., are transformed in a well known manner, the integration may be effected by (15). Thus

$$\begin{aligned} \cos mu \sin u \cos su &= \frac{1}{4} \{ \sin(1+m+s)u + \sin(1-m-s)u \\ &\quad + \sin(1+m-s)u + \sin(1-m+s)u \}; \end{aligned}$$

so that

$$\frac{1}{2} v \cdot A_r = \frac{1}{4} \pi \{ [1+m+s] + [1-m-s] + [1+m-s] + [1-m+s] \} \quad (39)$$

where each symbol such as  $[1+m+s]$  is to be replaced by  $\pm 1$ , the sign being that of  $(1+m+s)$ . In like manner

$$-\frac{1}{2} v \cdot D_r = \frac{1}{4} \pi \{ [1+m-s] + [1-m+s] - [1+m+s] - [1-m-s] \} \quad (40)$$

The  $r$ th terms of (35) are accordingly

$$\frac{\pi}{2v} \left\{ e^{isu} ([1+m+s] + [1-m-s]) + e^{-isu} ([1+m-s] + [1-m+s]) \right\}$$

or for the original series (32),

$$\frac{\pi}{2v} \left\{ e^{i(m+s)u} ([1 + m + s] + [1 - m - s]) + e^{i(m-s)u} ([1 + m - s] + [1 - m + s]) \right\} \quad (41)$$

For the term of zero order,

$$A_0 e^{imu} = \frac{\pi}{2v} e^{imu} ([1 + m] + [1 - m]). \quad (42)$$

From (41) we see that the term in  $e^{i(m+s)u}$  vanishes unless  $(m + s)$  lies between  $\pm 1$ , and that then it is equal to  $\pi/v \cdot e^{i(m+s)u}$ ; also that the term in  $e^{i(m-s)u}$  vanishes unless  $(m - s)$  lies between  $\pm 1$ , and that it is then equal to  $\pi/v \cdot e^{i(m-s)u}$ . In like manner the term in  $e^{imu}$  vanishes unless  $m$  lies between  $\pm 1$ , and when it does not vanish it is equal to  $\pi/v \cdot e^{imu}$ . This particular case is included in the general statement by putting  $s = 0$ .

The image of the grating, or row of points, expressed by (32), is thus capable of representation by the sum of terms

$$\pi/v \cdot \{ e^{imu} + e^{i(m+s_1)u} + e^{i(m-s_1)u} + e^{i(m+s_2)u} + \dots \} \quad (43)$$

where  $s_1 = 2\pi/v$ ,  $s_2 = 4\pi/v$ , &c., every term being included for which the coefficient of  $u$  lies between  $\pm 1$ . Each of these terms corresponds to a spectrum of Abbe's theory, and represents plane progressive waves inclined at a certain angle to the plane of the image. Each spectrum when it occurs at all contributes equally, and it goes out of operation suddenly. If but one spectrum operates, the field is of uniform brightness. If two spectra operate, we have the ordinary interference bands due to two sets of plane waves crossing one another at a small angle of obliquity.\*

Any consecutive pair of spectra give the same interference bands, so far as illumination is concerned. For

$$\frac{\pi}{v} \left\{ e^{iu[m+2r\pi/v]} + e^{iu[m+2(r+1)\pi/v]} \right\} = \frac{2\pi}{v} \cos \frac{\pi u}{v} e^{iu[m+2(r+\frac{1}{2})\pi/v]},$$

of which the exponential factor influences only the phase.

In (43) the critical value of  $v$  for which the  $r$ th spectrum disappears is given by, when we introduce the value of  $m$  from (33),

$$\frac{2\pi}{v} \left( \frac{\epsilon \sin \gamma}{\lambda} \pm r \right) = \pm 1;$$

or, since (as we have seen)  $\frac{v}{2\pi} = \frac{\epsilon \sin \alpha}{\lambda}$ , . . . . . (44)

$$\epsilon (\sin \gamma \mp \sin \alpha) = \mp r \lambda. \quad (45)$$

\* Enc. Brit., 'Wave Theory,' p. 425.

This is the condition, according to elementary theory, in order that the rays forming the spectrum of the  $r$ th order should be inclined at the angle  $\alpha$ , and so (fig. 118) be adjusted to travel from A to B, through the edge of the lens L.

The discussion of the theory of a rectangular aperture may here close. This case has the advantage that the calculation is the same whether the object be a row of points or a grating. A parallel treatment of other forms of aperture, e.g. the circular form, is not only limited to the first alternative, but applies there only to those points of the field which lie upon the line joining the geometrical images of the luminous points. Although the advantage lies with a more general method of investigation to be given presently, it may be well to consider the theory of a circular aperture as specially deduced from the formula (21) which gives the image of a single luminous centre.

If we limit ourselves to the case of parallel waves and perpendicular incidence, the infinite series to be discussed is

$$A(u) = \frac{J_1(u)}{u} + \frac{J_1(u+v)}{u+v} + \frac{J_1(u-v)}{u-v} + \frac{J_1(u+2v)}{u+2v} + \dots \quad (46)$$

where

$$u = \pi \xi \cdot 2R/\lambda f. \quad \dots \quad (47)$$

Since A is necessarily periodic in period  $v$ , we may assume

$$A(u) = A_0 + A_1 \cos(2\pi u/v) + \dots + A_r \cos(2r\pi u/v) + \dots; \quad (48)$$

and, as in the case of the rectangular aperture,

$$A_0 = \frac{1}{v} \int_{-\infty}^{+\infty} \frac{J_1(u)}{u} du, \quad A_r = \frac{2}{v} \int_{-\infty}^{+\infty} \frac{J_1(u)}{u} \cos \frac{2r\pi u}{v} du. \quad (49)$$

These integrals may be evaluated. If  $a$  and  $b$  be real, and  $a$  be positive,\*

$$\int_0^{\infty} e^{-ax} J_0(bx) dx = \frac{1}{\sqrt{(a^2 + b^2)}} \dots \quad (50)$$

Multiplying by  $b db$  and integrating from 0 to  $b$ , we find

$$\int_0^{\infty} \frac{J_1(bx) e^{-ax}}{x} dx = \frac{\sqrt{(a^2 + b^2)} - a}{b}. \quad \dots \quad (51)$$

In this we write  $b = 1$ ,  $a = is$ , where  $s$  is real. Thus

$$\int_0^{\infty} \frac{J_1(x) \{\cos sx - i \sin sx\}}{x} dx = \sqrt{(1 - s^2)} - is.$$

\* Gray and Mathews' 'Bessel's Functions,' 1895, p. 72.

If  $s^2 > 1$ , we must write  $i\sqrt{(s^2 - 1)}$  for  $\sqrt{(1 - s^2)}$ . Hence if  $s < 1$ ,

$$\int_0^\infty \frac{J_1(x) \cos sx}{x} dx = \sqrt{(1 - s^2)}, \quad . . . (52)$$

$$\int_0^\infty \frac{J_1(x) \sin sx}{x} dx = s; \quad . . . . . (53)$$

while, if  $s > 1$ ,

$$\int_0^\infty \frac{J_1(x) \cos sx}{x} dx = 0, \quad . . . . . (54)$$

$$\int_0^\infty \frac{J_1(x) \sin sx}{x} dx = -\sqrt{(s^2 - 1)} + s. \quad (55)$$

We are here concerned only with (52), (54), and we conclude that  $A_0 = 2/v$ , and that

$$A_r = \frac{4\sqrt{(1 - s^2)}}{v}, \quad \text{or } 0, \quad . . . (56)$$

according as  $s$  is less or greater than 1, viz. according as  $2r\pi$  is less or greater than  $v$ .

If we compare this result with the corresponding one (30) for a rectangular aperture of equal width ( $2R = a$ ), we see that the various terms representing the several spectra enter or disappear at the same time; but there is one important difference to be noted. In the case of the rectangular aperture the spectra enter suddenly and with their full effect, whereas in the present case there is no such discontinuity, the effect of a spectrum which has just entered being infinitely small. As will appear more clearly by another method of investigation, the discontinuity has its origin in the sudden rise of the ordinate of the rectangular aperture from zero to its full value.

In the method referred to the form of the aperture is supposed to remain symmetrical with respect to both axes, but otherwise is kept open, the integration with respect to  $x$  being postponed. Starting from (12) and considering only those points of the image for which  $\eta$  and  $q$  in equation (8) vanish, we have as applicable to the image of a single luminous source

$$C = \iint \cos px \, dx \, dy = 2 \int \hat{y} \cos px \, dx \quad . . . (57)$$

in which  $2y$  denotes the whole height of the aperture at the point  $x$ . This gives the amplitude as a function of  $p$ . If there be a row of luminous points, from which start radiations in the same phase, we have an infinite series of terms, similar to (57) and derived from it by the addition to  $p$  of positive and negative integral multiples of a constant ( $p_1$ ) representing the period.

The sum of the series  $A(p)$  is necessarily periodic, so that we may write

$$A(p) = A_0 + \dots + A_r \cos(2r\pi p/p_1) + \dots; \dots \quad (58)$$

and, as in previous investigations, we may take

$$A_r = \int_{-\infty}^{+\infty} C \cos sp \, dp, \dots \dots \dots \quad (59)$$

$s$  (not quite the same as before) standing for  $2r\pi/p_1$ , and a constant factor being omitted. To ensure convergency we will treat this as the limit of

$$\int_{-\infty}^{+\infty} e^{\pm hp} C \cos sp \, dp \dots \dots \dots \quad (60)$$

the sign of the exponent being taken negative, and  $h$  being ultimately made to vanish. Taking first the integration with respect to  $p$ , we have

$$\int_{-\infty}^{+\infty} e^{\pm hp} \cos xp \cos sp \, dp = \frac{h}{h^2 + (x+s)^2} + \frac{h}{h^2 + (x-s)^2};$$

and thus

$$A_r = \int \frac{hy \, dx}{h^2 + (x+s)^2} + \int \frac{hy \, dx}{h^2 + (x-s)^2},$$

in which  $h$  is to be made to vanish. In the limit the integrals receive sensible contributions only from the neighbourhoods of  $x = \pm s$ ; and since

$$\int_{-\infty}^{+\infty} \frac{du}{1+u^2} = \pi, \dots \dots \dots \quad (61)$$

we get

$$A_r = \pi (y_{x=-s} + y_{x=+s}) = 2\pi y_{x=s}. \dots \dots \dots \quad (62)$$

From (62) we see that the occurrence of the term in  $A_r$ , i.e. the appearance of the spectrum of the  $r$ th order, is associated with the value of a particular ordinate of the object-glass. If the ordinate be zero, i.e. if the abscissa exceed numerically the half-width of the object-glass, the term in question vanishes. The first appearance of it corresponds to

$$\frac{1}{2} a = 2r\pi/p_1 = r\lambda f/\xi_1,$$

in which  $a$  is the entire width of the object-glass and  $\xi_1$  the linear period in the image. By (17a),

$$\frac{\lambda f}{\xi_1} = \frac{\lambda f \sin \beta}{\epsilon \sin \alpha} = \frac{\frac{1}{2} a \lambda}{\epsilon \sin \alpha};$$

so that the condition is, as before,

$$\epsilon \sin \alpha = r\lambda.$$



When  $A_r$  has appeared, its value is proportional to the ordinate at  $x = s$ . Thus in the case of a circular aperture ( $a = 2R$ ) we have

$$y_{x=s} = R \sqrt{1 - r^2 \lambda^2 / \epsilon^2 \sin^2 \alpha}. \quad (63)$$

The above investigation relates to a row of luminous points emitting light of the same intensity and phase, and it is limited to those points of the image for which  $\eta$  (and  $q$ ) vanish. If the object be a grating radiating under similar conditions, we have to retain  $\cos qy$  in (12) and to make an integration with respect to  $q$ . Taking this first, and introducing a factor  $e^{\pm kq}$ , we have

$$\int_{-\infty}^{+\infty} e^{\pm kq} \cos qy \, dq = \frac{2k}{k^2 + y^2}. \quad (64)$$

This is now to be integrated with respect to  $y$  between the limits  $-y$  and  $+y$ . If this range be finite, we have

$$\text{Limit}_{k=0} \int_{-y}^{+y} \frac{2k \, dy}{k^2 + y^2} = 2\pi, \quad (65)$$

independent of the length of the particular ordinate. Thus

$$C_1 = \int_{-\infty}^{+\infty} C \, dq = 2\pi \int \cos px \, dx, \quad (66)$$

the integration with respect to  $x$  extending over the range for which  $y$  is finite, that is, over the width of the object-glass. If this be  $2R$ , we have

$$\int_{-\infty}^{+\infty} C \, dq = 4\pi/p \cdot \sin pR. \quad (67)$$

From (67) we see that the image of a luminous line, all parts of which radiate in the same phase, is independent of the form of the aperture of the object-glass, being, for example, the same for a circular aperture as for a rectangular aperture of equal width. This case differs from that of a *self-luminous* line, the images of which thrown by circular and rectangular apertures are of different types.\*

The comparison of (67) with (20), applicable to a circular aperture, leads to a theorem in Bessel's functions. For, when  $q$  is finite,

$$C = \pi R^2 \frac{2J_1 \{ \sqrt{(p^2 + q^2)} R \}}{\sqrt{(p^2 + q^2)}}; \quad (68)$$

so that, setting  $R = 1$ , we get

$$\int_0^{\infty} \frac{J_1 \{ \sqrt{(p^2 + q^2)} \}}{\sqrt{(p^2 + q^2)}} \, dq = \frac{\sin p}{p}. \quad (69)\dagger$$

\* Enc. Brit., 'Wave Theory,' p. 431.

† This may be verified by means of Neumann's formula (Gray and Mathews, 'Bessel's Functions' (70) p. 27).

The application to a grating, of which all parts radiate in the same phase, proceeds as before. If, as in (58), we suppose

$$\Lambda(p) = A_0 + \dots + A_r \cos sp + \dots; \quad . \quad . \quad (70)$$

we have

$$\Lambda = \int_{-\infty}^{+\infty} C_1 \cos sp \, dp; \quad . \quad . \quad . \quad (71)$$

from which we find that  $A_r$  is  $4\pi^2$  or 0, according as the ordinate is finite or not finite at  $x = s$ . The various spectra enter and disappear under the same conditions as prevailed when the object was a row of points; but now they enter discontinuously and retain constant values, instead of varying with the particular ordinate of the object-glass which corresponds to  $x = s$ .

We will now consider the corresponding problems when the illumination is such that each point of the row of points or of the grating radiates independently. The integration then relates to the intensity of the field as due to a single source.

By (9), (10), (11), the intensity  $I^2$  at the point  $(p, q)$  of the field, due to a single source whose geometrical image is situated at  $(0, 0)$  is given by

$$\begin{aligned} \lambda^2 f^2 I^2 &= \{ \iint \cos(px + qy) \, dx \, dy \}^2 + \{ \iint \sin(px + qy) \, dx \, dy \}^2 \\ &= \iint \cos(px' + qy') \, dx' \, dy' \times \iint \cos(px + qy) \, dx \, dy \\ &\quad + \iint \sin(px' + qy') \, dx' \, dy' \times \iint \sin(px + qy) \, dx \, dy \\ &= \iiiii \cos \{ p(x' - x) + q(y' - y) \} \, dx \, dy \, dx' \, dy' \quad (72) \end{aligned}$$

the integrations with respect to  $x', y'$ , as well as those with respect to  $x, y$ , being over the area of the aperture.

In the present application to sources which are periodically repeated, the term in  $\cos sp$  of the Fourier expansion representing the intensity at various points of the image has a coefficient found by multiplying (72) by  $\cos sp$  and integrating with respect to  $p$  from  $p = -\infty$  to  $p = +\infty$ . If the object be a row of points, we may take  $q = 0$ ; if it be a grating, we have to integrate with respect also to  $q$  from  $q = -\infty$  to  $q = +\infty$ .

Considering the latter case, and taking first the integrations with respect to  $p, q$ , we introduce the factors  $e^{\mp hp \mp kq}$ , the *plus* or *minus* being so chosen as to make the elements of the integral vanish at infinity. After the operations have been performed,  $h$  and  $k$  are to be supposed to vanish.\* The integrations are performed as for (60), (64), and we get the sum of the two terms denoted by

$$\frac{2hk}{\{h^2 + (x' - x \pm s)^2\} \{k^2 + (y' - y)^2\}} \quad . \quad . \quad (73)$$

\* The process is that employed by Stokes in his evaluation of the integral intensity, Edin. Trans., xx. p. 317 (1853). See also Enc. Brit., 'Wave Theory,' p. 431.

We have still to integrate with respect to  $dx dy dx' dy'$ . As in (65), since the range for  $y'$  always includes  $y$ ,

$$\text{Limit}_{k=0} \int \frac{2k dy'}{k^2 + (y' - y)^2} = 2\pi;$$

and we are left with

$$\iiint \frac{2\pi h dx dy dx'}{h^2 + (x' - x \pm s)^2} \dots \dots \dots (74)$$

If  $s$  were zero, the integration with respect to  $x'$  would be precisely similar; but with  $s$  finite it will be only for certain values of  $x$  that  $(x' - x \pm s)$  vanishes within the range of integration. Until this evanescence takes place, the limit when  $h$  vanishes becomes zero. The effect of the integration with respect to  $x'$  is thus to limit the range of the subsequent integration with respect to  $x$ . The result may be written

$$2\pi^2 \iint dx dy \dots \dots \dots (75)$$

upon the understanding that, while the integration for  $y$  ranges over the whole vertical aperture, that for  $x$  is limited to such values of  $x$  as bring  $x \mp s$  (as well as  $x$  itself) within the range of the horizontal aperture. The coefficient of the Fourier component of the intensity involving  $\cos sp$ , or  $\cos (2r\pi p/p_1)$ , is thus proportional to a certain part of the area of the aperture. Other parts of the area are inefficient, and might be stopped off without influencing the result.

The limit to resolution, corresponding to  $r = 1$ , depends only on the width of the aperture, and is therefore for all forms of aperture the same as for the case of the rectangular aperture already fully investigated.

If the object be a row of points instead of a row of lines,  $q = 0$ , and there is no integration with respect to it. The process is nearly the same as above, and the result for the coefficient of the  $r$ th term in the Fourier expansion is proportional to  $\int y^2 dx$ , instead of  $\int y dx$ , the integration with respect to  $x$  being over the same parts of the aperture as when the object was a grating. The application to a circular aperture would lead to an evaluation of

$$\int_{-\infty}^{+\infty} \frac{J_1^2(u) \cos su}{u^2} du.$$

VIII.—*On the Theory of Optical Images, with special reference to the Microscope.*

(SUPPLEMENTARY PAPER.)

By LORD RAYLEIGH.

*(Read June 17th, 1903.)*

IN the memoir, above reprinted from the *Philosophical Magazine*, I discussed the theories of Abbe and Helmholtz, and endeavoured to show their correlation. It appeared that the method of the former, while ingenious and capable of giving interesting results in certain directions, was inapplicable to many of the problems which it is necessary to attack. As an example of this, it may suffice to mention the case of a *self-luminous* object.

The work of Helmholtz, to which attention has recently been recalled by Mr. J. W. Gordon in a lively criticism (p. 381), was founded upon the processes already developed by Airy, Verdet, and others for the performance of the telescope. The theories both of Abbe and Helmholtz pointed to a tolerably definite limit to the powers of the Microscope, dependent, however, upon the wave-length of the light employed and upon the medium in which the object is imbedded. It appeared that two neighbours, whether constituting a single pair of points or forming part of an extended series of equidistant points, could not be properly distinguished if the distance were less than half the wave-length of the light employed. The importance of this conclusion, as imposing a limit upon our powers of direct observation, can hardly be overestimated; but there has been in some quarters a tendency to ascribe to it a more precise character than it can bear, or even to mistake its meaning altogether. A few words upon this subject may not be out of place.

The first point to be emphasised is that nothing whatever is said as to the smallness of a single object that may be made visible. The eye, whether unaided or armed with a telescope, is able to see as points of light stars subtending no sensible angle. The visibility of the star is a question of brightness simply, and has nothing to do with resolving power. The latter element enters only when it is a question of recognising the duplicity of a double star, or of distinguishing detail upon the surface of a planet. So in the Microscope there is nothing except lack of light to hinder the visibility of an object however small. But if its dimensions be much less than the half wave-length, it can only be seen as a whole, and its parts cannot be distinctly separated, although in cases near the border line some inference may be possible founded upon experience of what appearances are presented in various

cases. Thus a practised astronomer may conclude with certainty that a star is double, although its components cannot be properly seen. He knows that a single star would present a round (though false) disc, and any departure from this condition of things he attributes to a complication. A slightly oval disc may suffice not only to prove that the star is double but even to fix the line upon which the components lie, and their probable distance apart.

What has been said about a luminous point applies equally to a luminous *line*. If bright enough, it will be visible, however narrow; but if the real width be much less than the half wave-length the apparent width will be illusory. The luminous line may be regarded as dividing the otherwise dark field into two portions; and we see that this separation does not require a luminous interval of finite width, but may occur, however narrow the interval, provided that its intrinsic brightness be proportionally increased.

The consideration of a luminous line upon a dark ground is introduced here for comparison with the case, suggested by Mr. Gordon, of a dark line upon a (uniformly) bright ground. Calculations to be given later confirm Mr. Gordon's conclusion that the line may be visible (but not in its true width), although the actual width fall considerably short of the half wave-length. Although in both these cases there is something that may be described as resolution, what is seen as distinct from the ground is really but a *single* object. So far as I see, there is no escape from the general conclusion, as to the microscopic limit, glimpsed originally by Fraunhofer and afterwards formulated by Abbe and Helmholtz; but it must be remembered that near the limit the question is one of degree, and that the degree may vary with the character of the detail whose visibility is under consideration.

Mr. Gordon comments upon the fact that Helmholtz gave no direct proof of his pronouncement that a grating composed of parallel, equidistant, infinitely narrow, luminous lines shows no structure at a certain degree of closeness, and he appears to regard the question as still open. This matter was, however, fully discussed in my paper of 1896 (see above), where it is proved that as the grating interval diminishes, structure finally disappears when the distance between the geometrical images of neighbouring lines falls to equality with half the width of the diffraction pattern due to a single line, reckoned from the first blackness on one side to the first blackness on the other. It is easy to see that the same limit obtains when the lines have a finite width, provided, of course, that the widths and intrinsic luminosities of the lines are equal. If the *grating-interval*, that is the distance between centres or *corresponding* edges of neighbouring lines, be less than the amount above mentioned, no structure can be seen. The

microscopic limit occurs when the grating-interval is equal to half the wave-length of the light in operation.

The method employed in 1896 depends upon the use of Fourier's theorem. The critical case, where the structure has *just* disappeared, may be treated in a somewhat more elementary manner as follows. It is required to prove that

$$\frac{\sin^2 u}{u^2} + \frac{\sin^2(u + \pi)}{(u + \pi)^2} + \frac{\sin^2(u - \pi)}{(u - \pi)^2} \\ + \frac{\sin^2(u + 2\pi)}{(u + 2\pi)^2} + \frac{\sin^2(u - 2\pi)}{(u - 2\pi)^2} + \dots, \quad (76)$$

obtained by writing  $\pi$  for  $v$  in (22) above, is the same for all values of  $u$ . In (76) the  $(\sin)^2$  have all the same value, so that what has to be proved may be written

$$\frac{1}{\sin^2 u} = \frac{1}{u^2} + \frac{1}{(u + \pi)^2} + \frac{1}{(u - \pi)^2} + \frac{1}{(u + 2\pi)^2} + \dots \quad (77)$$

This follows readily from the expression for the sine in factors. If we write

$$\sin u = C u (u + \pi) (u - \pi) (u + 2\pi) \dots,$$

or

$$\log \sin u = \log C + \log u + \log(u + \pi) + \dots,$$

we get on differentiation

$$\frac{d \log \sin u}{du} = \frac{1}{u} + \frac{1}{u + \pi} + \frac{1}{u - \pi} + \dots,$$

and again

$$-\frac{d^2 \log \sin u}{du^2} = \frac{1}{u^2} + \frac{1}{(u + \pi)^2} + \frac{1}{(u - \pi)^2} + \dots$$

In these equations

$$\frac{d \log \sin u}{du} = \cot u, \quad -\frac{d^2 \log \sin u}{du^2} = \frac{1}{\sin^2 u},$$

from which (77) follows.

We infer that a grating of the degree of closeness in question presents to the eye a uniform field of light and no structure, but it is not proved by this method that structure might not reappear at a greater degree of closeness. If however we take  $v = \frac{1}{2}\pi$ , that is, suppose the lines to be exactly twice as close as above, a similar method applies. The illumination at the point is now expressed by

$$\frac{\sin^2 u}{u^2} + \frac{\sin^2(u + \frac{1}{2}\pi)}{(u + \frac{1}{2}\pi)^2} + \frac{\sin^2(u - \frac{1}{2}\pi)}{(u - \frac{1}{2}\pi)^2} + \dots,$$

or by

$$\sin^2 u \left\{ \frac{1}{u^2} + \frac{1}{(u + \pi)^2} + \frac{1}{(u - \pi)^2} + \frac{1}{(u + 2\pi)^2} + \dots \right\}$$

$$+ \cos^2 u \left\{ \frac{1}{(u + \frac{1}{2}\pi)^2} + \frac{1}{(u - \frac{1}{2}\pi)^2} + \frac{1}{(u + \frac{3}{2}\pi)^2} + \dots \right\}$$

The value of the first series has above been shown to be unity, and by a like method the same may be proved of the second. The illumination for all values of  $u$  is thus equal to 2. That it should be twice as great as before might have been expected.

But my principal object at present is to consider the problem, suggested by Mr. Gordon, of a dark line of finite width upon a uniformly bright ground. The problem assumes two forms according as the various parts of the ground are supposed to be self-luminous or to give rise to waves which are all in one phase. The latter is the case of an opaque wire or other linear obstacle upon which impinge plane waves of light in a direction parallel to the axis of the instrument (telescope or Microscope), and as it is somewhat the simpler we may consider it first.\*

In (28) we have the expression for the resultant amplitude at any point  $u$  due to a series of points or lines, whose geometrical images are situated at  $u = 0, u = \pm v, u = \pm 2v, \&c.$  If all values of  $u$  are equally geometrical images of a uniformly bright ground of light, we have to consider

$$\int_{-\infty}^{+\infty} \frac{\sin u}{u} du = \pi. \quad \dots \quad (78)$$

At present we suppose that the bright ground is interrupted at points corresponding to  $u = a, u = -a$ , so that  $2a$  represents the width of the geometrical image of the dark obstacle. The amplitude at  $u$  is the same for a given numerical value of  $u$ , whether  $u$  be positive or negative. It will suffice therefore to suppose  $u$  positive. If  $u < a$ , we have

$$A(u) = \int_{-\infty}^{+\infty} \frac{\sin u}{u} du - \int_0^{a-u} \frac{\sin u}{u} du$$

$$- \int_0^{a+u} \frac{\sin u}{u} du \quad \dots \quad (79)$$

\* It should be remarked that in point of fact the field is limited through the operation of a cause not taken into account in the formation of (28). It is there assumed that equality of phase in the light emitted from the various points of the object carries with it a like equality of phase at the geometrical images of these points. This will hold good only near the centre of the field. At a moderate distance out the illumination is destroyed by the phase-differences here neglected.

which gives the resultant amplitude at any point  $u$  as a function of  $u$  and  $a$ . If  $u > a$ , we have

$$A(u) = \int_{-\infty}^{+\infty} \frac{\sin u}{u} du + \int_0^{u-a} \frac{\sin u}{u} du - \int_0^{u+a} \frac{\sin u}{u} du. \quad (80)$$

By (78) the first term is equal to  $\pi$ .

The integral in (79), (80) is known as the *sine-integral*. In the usual notation

$$\int_0^x \frac{\sin u}{u} du = \text{si}(x). \quad (81)$$

so that (79) may be written

$$A(u) = \pi - \text{si}(a-u) - \text{si}(a+u). \quad (82)$$

and (80) may be written

$$A(u) = \pi + \text{si}(u-a) - \text{si}(u+a). \quad (83)$$

The function *si* has been tabulated by Dr. Glaisher.\*

At the centre of the geometrical image of the bar,  $u = 0$ , and (82) becomes

$$A(0) = \pi - 2 \text{si}(a). \quad (84)$$

If  $x$  is small, (81) gives

$$\text{si}(x) = x - \frac{x^3}{3 \cdot 1 \cdot 2 \cdot 3} + \frac{x^5}{5 \cdot 1 \cdot 2 \cdot 3 \cdot 4 \cdot 5} - \dots; \quad (85)$$

so that in (82) if  $a$  be small,

$$A(u) = \pi - 2a + \frac{2a(a^2 + 3u^2)}{3 \cdot 1 \cdot 2 \cdot 3} - \dots \quad (86)$$

From this we see that over the whole geometrical image of the bar the amplitude of vibration is nearly the same. If we write  $I$  for the intensity, where  $I(u) = \{A(u)\}^2$ , and denote by  $I_0$  the value of  $I$  corresponding to a uniform ground ( $a = 0$ ), then

$$\frac{I_0 - I}{I_0} = \frac{4a}{\pi}. \quad (87)$$

This gives the proportional loss of illumination over the image of the bar, and it suffices for the information required near the limit of visibility. For example, if the loss of light over the

\* Phil. Trans., 1870.



image be one-eighth of the maximum,  $2a = \frac{1}{16}\pi$ ; so that a single bar upon a bright ground might well remain apparent when its width is reduced to  $\frac{1}{32}$  of the minimum grating-interval ( $2\pi$ ) necessary for visibility.

The above gives the loss of brightness over the region occupied by the geometrical image. Outside this region we have from (80), when  $2a$  is small,

$$A(u) = \pi - \int_{u-a}^{u+a} \frac{\sin u}{u} du = \pi - 2a \frac{\sin u}{u}, \quad (88)$$

whence

$$\frac{I_0 - I(u)}{I_0} = \frac{4a}{\pi} \frac{\sin u}{u} \quad (89)$$

Here (89) identifies itself with (87) when  $u$  is small, and it does not alter greatly until  $u = \frac{1}{2}\pi$ . The slightly darkened image of the bar has thus a width corresponding to the interval  $u = \pm \frac{1}{2}\pi$ , exceeding to a great extent the width of the geometrical image when the latter is very small. The conclusion is that, although a very narrow dark bar on a bright ground may make itself visible, the apparent width is quite illusory.

A (u).

$\pm u$	$a = 1$	$a = 2$	$a = 3$
0	+ 1.520	- .068	- .556
1	1.807	+ .347	- .221
2	2.509	1.384	+ .646
3	3.259	2.538	1.717
4	3.711	3.322	2.633
5	3.745	3.536	3.173
6	3.507	3.326	3.326
7	3.263	3.027	3.242
8	2.932	2.909	3.114

The annexed table gives the values of A (u) for  $a = 1, 2, 3$  for  $u = 0, 1 \dots 8$ . Corresponding to any value of  $a$ ,

$$u(\infty) = \pi = 3.142.$$

It will be remembered that  $2a$  is the width of the geometrical image of the bar, so that when  $a = 3$  the width is about the same as the minimum resolvable grating interval ( $2\pi$ ).

We now pass to the case of a *self-luminous* ground interrupted by a dark bar. As in (22), we have for the illumination at any point  $u$  within the geometrical image

$$I(u) = \int_{-\infty}^{+\infty} \frac{\sin^2 u}{u^2} du - \int_0^{a-u} \frac{\sin^2 u}{u^2} du - \int_0^{a+u} \frac{\sin^2 u}{u^2} du \quad . \quad . \quad (90)$$

and for any point on the positive side beyond the geometrical image

$$I(u) = \int_{-\infty}^{+\infty} \frac{\sin^2 u}{u^2} du + \int_0^{u-a} \frac{\sin^2 u}{u^2} du - \int_0^{u+a} \frac{\sin^2 u}{u^2} du, \quad . \quad . \quad (91)$$

$2a$  denoting as before the width of the geometrical image of the bar, while  $u$  is reckoned from the centre of symmetry. If  $a = 0$ ,

$$I(u) = \int_{-\infty}^{+\infty} \frac{\sin^2 u}{u^2} du = \pi. \quad . \quad . \quad (92)$$

The integrals in (90), (91) may be reduced to dependence upon the sine-integral. It may be proved\* that

$$\begin{aligned} \int_0^x \frac{\sin^2 u}{u^2} du &= \int_0^{2x} \frac{\sin u}{u} du - \frac{\sin^2 x}{x} \\ &= \text{si}(2x) - \frac{\sin^2 x}{x} \quad . \quad . \quad . \quad (93) \end{aligned}$$

Thus, inside the geometrical image,

$$\begin{aligned} I(u) &= \pi - \text{si}(2a - 2u) + \frac{\sin^2(a - u)}{a - u} \\ &\quad - \text{si}(2a + 2u) + \frac{\sin^2(a + u)}{a + u}; \quad . \quad (94) \end{aligned}$$

and beyond it,

$$\begin{aligned} I(u) &= \pi + \text{si}(2u - 2a) - \frac{\sin^2(u - a)}{u - a} \\ &\quad - \text{si}(2u + 2a) + \frac{\sin^2(u + a)}{u + a} \quad . \quad . \quad (95) \end{aligned}$$

\* E.g. by writing  $ru$  for  $u$  in the integral to be examined and differentiating with respect to  $r$ . Or (93) may be verified by differentiating with respect to  $x$ .

At the centre ( $u = 0$ )

$$I(0) = \pi - 2 \operatorname{si}(2\alpha) + \frac{2 \sin^2 \alpha}{\alpha} \quad \dots \quad (96)$$

As in the former case an approximate expression (85) for  $\operatorname{si}(x)$  gives the desired information near the limit of visibility. If  $\alpha$  be small, we have for the illumination within the geometrical image from (90)

$$I(u) = \pi - 2\alpha, \quad \dots \quad (97)$$

so that

$$\frac{I_0 - I}{I_0} = \frac{2\alpha}{\pi} \quad \dots \quad (98)$$

The visibility of a bar of width  $2\alpha$  is thus only half as great as before.

Outside the geometrical image we have approximately, when  $u$  considerably exceeds  $\alpha$ ,

$$\begin{aligned} I(u) &= \pi - \int_{u-\alpha}^{u+\alpha} \frac{\sin^2 u}{u^2} du \\ &= \pi - 2\alpha \frac{\sin^2 u}{u^2}, \quad \dots \quad (99) \end{aligned}$$

whence

$$\frac{I_0 - I(u)}{I_0} = \frac{2\alpha \sin^2 u}{\pi u^2} \quad \dots \quad (100)$$

The following table gives some values of  $I(u)$  calculated from (94), (95).

$I(u)$ .

$\pm u$	$\alpha = \frac{1}{2}$	$\alpha = 1$	$\alpha = 2$
0	2.170	1.349	.453
1	2.442	1.797	.827
2	2.921	2.621	1.711
3	..	3.056	2.565

The complete value of  $I(u)$ , when  $u$  is great, is  $\pi$ . The width of the geometrical image of the bar is  $2\alpha$ , and the smallest resolvable grating interval is  $\pi$ . The dark bar should be easily recognisable in the first case when its width is but one-third of the minimum grating interval.

In conclusion I may mention the results of a simple experiment conducted almost entirely without apparatus. In front of the naked eye was held a piece of copper foil perforated by a fine needle-hole. Observed through this the structure of some gauze

just disappeared at a distance from the eye equal to 17 in. (inch = 2.54 cm.), the gauze containing 46 meshes to the inch. On the other hand, a single wire .034 in. in diameter remained fairly visible up to a distance of 20 ft. or 240 in. The ratio between the angles subtended by the periodic structure of the gauze and the diameter of the wire was thus

$$\frac{\cdot 022}{\cdot 034} \times \frac{240}{17} = 9 \cdot 1.$$

Using this in (98), we find for the proportional loss of illumination at the centre of the wire

$$\frac{I - I_0}{I_0} = \cdot 11,$$

about what might have been expected.

TERLING PLACE, WITHAM.

SUMMARY OF CURRENT RESEARCHES  
RELATING TO  
ZOOLOGY AND BOTANY  
(PRINCIPALLY INVERTEBRATA AND CRYPTOGAMIA),  
MICROSCOPY, ETC.\*

---

ZOOLOGY.

VERTEBRATA.

a. Embryology.†

**Treatise on Comparative and Experimental Embryology.**‡—O. Hertwig's great treatise continues to appear in instalments which follow in rapid succession. Waldeyer deals in an almost monographic manner with the sex-cells; R. Hertwig treats of maturation, fertilisation, and cleavage; the editor discusses the theory of the germinal layers.

**Laboratory Text-Book of Embryology.**§—Charles Sedgwick Minot has adapted part of his great book on 'Human Embryology' for use in laboratory work. The aim of the new text-book is to utilise sections of embryos as a basis for the morphological interpretation of adult structure and in illustration of biological principles and pathological processes. After a general chapter, the author discusses the early stages in mammals, the human embryo till the fourth month, embryos of the pig, embryos of the fowl, germinal layers and cleavage, the uterus and the foetal appendages, and finally methods.

**Influence of Radium Rays on Tadpoles.**||—G. Bohn finds that these mysterious rays have a distinct but variable effect on the growth of the tadpoles of frogs and toads, sometimes making it slower, sometimes quickening it, sometimes destroying tissue, and sometimes inducing monstrosity. He indicates that an effect produced during the tadpole stage may remain as it were latent until the metamorphosis, when a monstrosity suddenly results.

**Influence of Radium Rays on Ova.**¶—G. Bohn has made over forty experiments with the ova of *Strongylocentrotus lividus*, which were placed

\* The Society are not intended to be denoted by the editorial "we," and they do not hold themselves responsible for the views of the authors of the papers noted, nor for any claim to novelty or otherwise made by them. The object of this part of the Journal is to present a summary of the papers *as actually published*, and to describe and illustrate Instruments, Apparatus, &c., which are either new or have not been previously described in this country.

† This section includes not only papers relating to Embryology properly so called, but also those dealing with Evolution, Development, Reproduction, and allied subjects.

‡ 'Handbuch der vergleichenden und experimentellen Entwicklungslehre der Wirbeltiere,' Bd. i. Lief 9-13, 8vo, Jena, 1902-3.

§ 'A Laboratory Text-Book of Embryology,' 8vo, Philadelphia, xvii. and 380 pp., 218 figs.

|| Comptes Rendus, cxxxvi. (1903) pp. 1012-3.

¶ Tom. cit., pp. 1085-6.

near a tube of radium. It seems as if the rays acted on the chromatin of the nucleus, increasing its activity or after a while destroying it. They destroy spermatozoa (practically naked chromatin), but excite the protected chromatin of the ovum and determine parthenogenesis. They induce on the chromatin of the fertilised ovum certain durable effects which are as if they were retained unexpressed until growth or renovation sets in. There seems to be no effect on tissues except when they are in process of growth or differentiation.

**Influence of Alcohol on Development.\***—H. E. Ziegler has experimented with the ova of the sea-urchins *Echinus microtuberculatus* and *Strongylocentrotus lividus* to test the influence of alcohol on development. The presence of 0.5–1 p.c. does not result in serious injury, normal Plutei may result, but there seem to be marked individual differences in susceptibility. The presence of 2 p.c. seriously disturbs development, and seems to act as a poison, as Rauber also found.† The cleavage is slow and often abnormal, only a few blastulæ are formed, the blastocoel tends to be too small, there are too many mesenchyme cells. Gastrulation is sluggish, the mesenchyme cells have not their normal arrangement, if a skeleton is formed at all it is abnormal, Plutei with well-developed arms do not occur. With 3 p.c. of alcohol in the seawater, few blastulæ are formed, and there is no gastrulation. With 4 p.c. no blastulæ are developed.

The general result is a disturbance of the cell-division; it tends to be inhibited. Thus there may be nuclear division without cell-division. Another noteworthy effect is an inhibition of cell-movements, e.g. in gastrulation. Of especial interest is the formation of larvæ without any skeleton,—as if they were a return to a more primitive larval type.

**Œstrous Cycle and Corpus Luteum in Sheep.‡**—F. H. A. Marshall finds that in Scottish black-faced sheep the length of the sexual season varies with the locality, both in regard to the number of diœstrous cycles in a season and to the duration of each cycle. There is a perfect gradation between the monœstrous condition of some wild sheep and the extreme polyœstrum of certain merinos.

The proœstrum is marked by a mucous or sanguineo-mucous flow. It is very rapidly succeeded by œstrus (the period of desire), the two periods frequently seeming to occur simultaneously because of the abbreviation of the process.

The changes through which the sheep's uterus passes during a single diœstrous cycle can be divided into four periods:—(1) period of rest; (2) period of growth and increase of vessels; (3) period of breaking down of vessels and extravasation of blood; and (4) period of recuperation and pigment formation. The homology between the diœstrous cycle in the sheep and the menstrual cycle of the Primates is rendered very probable.

Ovulation can occur spontaneously at any œstrous (or pro-œstrous) period with Scottish black-faced sheep, excepting at certain œstri outside

\* Biol. Centralbl., xxiii. (1903) pp. 448–55 (5 figs.).

† 'Wirkungen des Alcohols auf Tiere und Pflanzen,' Leipzig, 1902.

‡ Proc. R. Soc. London, lxxi. (1903) pp. 354–5.

the regular sexual season, when the additional stimulation supplied by coition may be necessary. In the ferret, ovulation does not occur in the absence of coition, without which the follicles undergo atresia.

In the sheep, atresia is commonest in follicles of about  $\frac{1}{3}$ – $\frac{1}{2}$  the dimensions of the mature follicles. When it occurs with any considerable frequency, it must affect the barrenness percentage in subsequent breeding seasons. The atretic follicle differs from the developing corpus luteum in the absence of any discharge to the exterior; the membrana granulosa degenerates and disappears prior to any considerable ingrowth from the connective-tissue wall.

As to the formation of the corpus luteum, the lutein cells are derived from the membrana granulosa, while the connective-tissue element is supplied by the proliferation and ingrowth of the theca interna and externa. Leucocytes are abundant, especially at the sixteenth-hour stage of development, but these disappear in later stages without giving rise to connective tissue as described by Sobotta. The cavity of the discharged follicle is filled in by the further ingrowth of connective tissue.

Perhaps the most important result is the additional evidence as to the identity of the two processes of pro-œstrum and menstruation.

**Yolk-Nucleus or Corpus Balbiani in Vertebrates.\***—K. v. Skrobansky has studied this much discussed body in the ova of the guinea-pig. The question is, whether it represents morphologically and genetically a "sphere-apparatus" (idiozome, centrotheca, or centriole), or whether it is a quite distinct structure. According to the author's observations, the formation of the body is not associated with the division of the oogonia, and the corpuscle cannot therefore be identified as a sphere-apparatus. Herein he agrees especially with Gurwitsch.

**Determination of Sex.†**—B. S. Schultze indicates that as long ago as 1855 he maintained that sex was determined even before fertilisation. It may be that the older the father is in relation to the mother, the more male offspring there will be (Hofacker and Sadler). It may be that a sire which functions frequently will have relatively more male offspring than one which serves less frequently (the conclusion of many breeders). But these conclusions are not antagonistic to the theory of "progamic" determination.

The "masculine ova" leaving the ovary of the young female may have more attraction for the spermatozoa of the older male parent than the "feminine ova" have. The "masculine ova" may attract spermatozoa fresh from the testes more than the "feminine ova," which may be relatively more accessible to spermatozoa which have been longer in the testes. It is evident that there are many "may-be's" to be considered before this difficult problem can be regarded as scientifically settled.

**Development of Spleen in *Tropidonotus natrix*.‡**—W. Tonkoff has shown previously that in various Anniota the primordium of the

\* Arch. Mikr. Anat., lxii. (1903) pp. 194–206 (1 pl.).

† Centralbl. f. Gynäk., 1903, pp. 1–4. See Zool. Centralbl., x. (1903) p. 372

‡ Anat. Anzeig., xxiii. (1903) pp. 214–6.

spleen always arises as a dense aggregate of mesenchyme cells with simultaneous co-operation on the part of the proliferating cœlomic epithelium. He maintains that the spleen is purely mesodermic, without direct developmental association with the dorsal pancreas or with any endoderm. E. Glas has maintained that in the grass-snake, the origin of the spleen is distinctly endodermic, and bound up with the origin of the dorsal pancreas.

Examination of embryos of this snake leads Tonkoff to reaffirm his conclusion. In this case also the spleen arises from a mesenchyme aggregate, quite independently of the dorsal pancreas, with which it is secondarily connected.

**Development of Teeth in Selachians.\***—P. Laaser finds that a dental ridge appears very early in embryos (3–4 cm. in length) of *Spinax*, *Acanthias*, and *Mustelus*, as a slight thickening of the epithelium with a subjacent mesenchyme thickening. In embryos of *Spinax* and *Acanthias* it appears earlier in the lower jaw; in embryos of *Mustelus* it appears earlier in the upper jaw.

Not only do the teeth arise on the dental ridge, but the outer dental epithelium shares directly in their formation exactly after the fashion of placoid scales. At the margin of the outer dental epithelium there is a groove (the external marginal-groove) which must not be confused with the lip-groove.

The first teeth-rudiments appear on the transition area from external dental epithelium to dental ridge. They are developed earlier than those on the external dental epithelium or those on the dental ridge. The first hard substance to be formed is dentine; the enamel covering is not to be seen in the early stages. Very early there appears to the inside of the dental ridge, above and below, an inturned fold of the buccal mucous membrane,—the internal mouth-fold. This afterwards forms the internal margin of the buccal cavity.

**Preputial Glands of Rabbit.†**—Dr. Courant has made a study of the glandulæ præputiales and the changes which they exhibit. There is a “white gland” which is merely an aggregated sebaceous gland, and a “brown gland” which is peculiar, and morphologically nearer the sudorific type. The brown preputial gland exhibits periodic changes, which are described. The changes are in all probability associated with the period of rut, but the evidence is not quite conclusive. Courant regards their function as conducive to sexual attraction by the secretion of a strongly smelling substance.

**Non-Existence of “Neutrophil” Granulations in Leucocytes of Man and Monkey.‡**—F. Marino finds that Ehrlich’s classification of the leucocyte-granulations in the blood of man and monkeys is not altogether verifiable. Ehrlich distinguished (a) eosinophil or oxyphil granulations staining with acid stains, (b) basophil or metachromic granulations which take on basic stains, and (c) neutrophil granulations which will stain only in neutral mixtures. But Marino finds that the

\* *Jenaische Zeitschr. f. Naturwiss.*, xxxvii. (1903) pp. 551–78 (1 pl. and 13 figs.).

† *Arch. Mikr. Anat.*, lxii. (1903) pp. 175–93 (2 pls.).

‡ *Ann. Inst. Pasteur*, xvii. (1903) pp. 357–64 (1 pl.).



third class is really non-existent; the alleged neutrophil granulations stain either with acid or basic stains, and retain them.

#### b. Histology.

**Intercellular Connections.\***—A. Schuberg has shown in great detail that intercellular connections between the epidermic epithelium and the connective-tissue cells of the corium are in the case of the axolotl beyond all doubt real.

**Minute Structure of Amphioxus.†**—J. Boeke describes (*a*) the structure of the light-perceptive cells segmentally arranged on the spinal cord, (*b*) the neurofibrils in the ganglion-cells, and (*c*) the innervation of the striped muscular tissue.

**Efferent Neurons in Electric Lobes of Torpedo.‡**—Shinkishi Hatai finds that the efferent neurons of the electric lobes of *Torpedo occidentalis* present a fibrillar appearance of the ground substance. But this is due to an alteration in the shape of the meshes of the reticulum, and cannot be compared with the fibrils described by Bethe, Apáthy, and others. The meshes of the reticulum, which the author regards as primitive, are altered by the growth of the cell-body where the processes, both axone and dendrite, arise and become extremely elongated in these branches. Gradations from the primitive shape of the meshes to the altered form which appears fibrillar, are clearly visible in the spinal ganglion-cells of the white rat.

**Blood-Vessels of the Spinal Cord of Birds.§**—G. Sterzi has studied in detail the arteries and veins associated with the spinal cord of duck, fowl, pigeon, owl, and parrot. He gives a minute description, but we cannot do more than note that the disposition of the vessels in the various species studied displays adherence to a constant type or mode of distribution.

**Historical Aspects of Zoology.||**—R. Burckhardt emphasises the need for some vigorous work in regard to the history of zoology as a science. He discusses the biological expansion of zoology, the classification of the various departments, the historical development of these, and especially the relation between "physiological systematik" and "comparative anatomical systematik."

#### c. General.

**Parasitism among Animals.¶**—F. von Wagner has in a booklet—a marvel of cheapness—discussed, (1) parasitism in general, its modes, its results on parasite and on host, and so forth, and (2) the most important parasites on man and his domestic animals.

**Morphology of the Myxinoids.\*\***—Howard Ayers and C. M. Jackson have discovered a series of rudimentary gill-bars in *Bdellostoma*, and

\* Zeitschr. f. wiss. Zool., lxxiv. (1903) pp. 155-325 (7 pls.).

† Proc. Section of Sciences k. Akad. Amsterdam, v. (1902) pp. 350-8 (6 figs.).

‡ Bull. Univ. Cincinnati, ser. 2, vol. i. (1901, received 1903) pp. 1-12 (1 pl.).

§ Arch. Anat. Embriol., ii. (1903) pp. 216-36 (1 pl.).

¶ Verh. Nat. Ges. Basel, xvi. (1903) pp. 388-440.

\*\* 'Schmarotzer und Schmarotzertum in der Tierwelt,' 8vo, Leipzig, 1902. See Biol. Centralbl., xxiii. (1903) p. 387.

\*\* Bull. Univ. Cincinnati, ser. 2, vol. i. (1900, received 1903) pp. 5-15 (2 pls.).

seek to establish a series of homologies between the circumoral and "lingual" regions in *Bdellostoma* and *Petromyzon*. They also maintain that the so-called "tongue" of the Marsipobranchs is in reality the detached lower jaw. Therefore the Marsipobranchs are true *Gnathostomes*, forming a primitive group which probably sprang from the common ancestry before the acquisition of paired appendages by the vertebrate stock.

**Note on Phrynosoma.\***—C. L. Edwards points out that Gadow is mistaken in stating in 'The Cambridge Natural History' that all the species of *Phrynosoma* are viviparous. The fact is that the genus contains viviparous species, e.g. *Ph. douglassii*, but also oviparous species, e.g. *Ph. cornutum* of Texas, whose nest-building and ovulation Edwards has described.

**Functional Inequality of the Kidneys.†**—J. Albarran refers to the general belief, which has some definite basis, that the kidneys function equally. His experiments on dogs and man do not confirm this. He found that in the same time the two kidneys excreted different quantities of urine and of dissimilar composition. The details of the inequality are given, but it does not seem to us that the number of cases and experiments was sufficient to warrant generalisation, though the facts stated are undoubtedly interesting.

**Normal Presence of Arsenic in Animals.‡**—G. Bertrand has applied his delicate methods for the detection of arsenic to a great variety of animals from sponge to man. The metalloid seems to be present in every case and in all sorts of tissues, and the author thinks that it should be ranked like carbon, nitrogen, sulphur, or phosphorus as an essential component of living matter.

**Arsenic in Eggs of Fowl.§**—G. Bertrand supports his view that arsenic is a constant—perhaps physiologically necessary—component of all cells by demonstrating that it occurs in appreciable quantity in all parts of the hen's egg. The yolk has most, the white least, but even the keratinoid shell-membrane gives the reaction.

**Formation of Black Pigment in Tumours of Horse.||**—C. Gessard refers to the recognised physical and chemical similarity of the melanin of the eye, skin, &c. of mammals to the melanin of cuttlefish ink. He has studied the melanic tumours of white horses, and finds that the melanin is formed by the same biochemical process as that involved in the production of cuttlefish ink. There are two agents involved, an oxidising ferment and a chromogen.

He finds that tyrosin is the chromogen whose oxidation by tyrosinase determines the formation of black pigment in many normal and abnormal products in the animal series. One may say indeed that the colour of the negro is due to the same reaction as that which occurs in making the ink of the cuttlefish or the black of certain fungi.

\* Science, xvii. (1903) pp. 826-7.

† Comptes Rendus, cxxxvi. (1903) pp. 1207-10.

‡ Ann. Inst. Pasteur, xvii. (1903) pp. 1-10.

§ Comptes Rendus, cxxxvi. (1903) pp. 1033-5.

|| Tom. cit., pp. 1086-8.

**Growth in Weight of White Mice.\***—M. Stefanowska has plotted out curves for both sexes, and finds four main periods. There is first a period of slow increase until the 16th day. Then follows a long period of maximum rate of increase from the 16th to the 45th day. The third period, from the 45th to the 67th day, corresponding to the advent of puberty, is especially marked by its irregular course, a descent, a rise, and an arrest. In the fourth period, from the 67th day until mature size (91st day) the growth proceeds again slowly. There is a close parallelism in the curves for the two sexes.

**Vascular System of Amphioxus.†**—R. Legros has filled some of the many gaps in our knowledge of the vascular system in this type. He gives a detailed account of the vessels, and does not find any evidence to support the view that the vascular system communicates with any truly cœlomic space. The vessels are definitely closed by a continuous endothelial lining.

Legros directs particular attention, in addition to his discovery of a trapeze muscle on the right side, to the parietal cœlomic canals which connect the sub-chordal cœlom of the branchial region with the perigonadial cœlomic cavities, and to the ascending visceral branch of certain dorsal nerves (27th–31st).

#### Tunicata.

**Function of Ganglion in *Ciona intestinalis*.‡**—R. Magnus has experimented on this favourable subject for testing the function of the Tunicate's central nervous system. The system is reduced, as is well known, to a single ganglion from which the musculature of the body-wall is innervated. There is but one characteristic reflex, namely, a closing of the apertures and a retraction of the whole animal if one of the syphons is touched. Loeb has maintained that this reflex persists after the ganglion has been extirpated, and supposes a propagation of the stimulus from muscle-cell to muscle-cell.

Magnus finds, however, that extirpation of the ganglion puts an end (for the time being) to the reflex, and leaves only local reactions possible. After extirpation there is no transmission of stimulus from one side of the body to another, or from one syphon to another. Only local reactions occur.

After two or three weeks, however, the original reflex may suddenly reappear, and then it is found that the ganglion has been regenerated. There is no warrant for supposing that there is a transmission of stimulus from muscle-fibre to muscle-fibre. The ganglion is a true and indispensable reflex-centre.

**Digestive Glands of *Monascidiæ*.§**—A. Isert describes in detail the structure of the main digestive gland in a number of solitary ascidians. The organ is most developed in *Microcosmidæ*, *Cynthiæ*, and *Molgulidæ*, where it is a distinctly visible organ in direct connection with the stomach. In other forms there is rather a glandular region

\* *Comptes Rendus*, cxxxvi. (1903) pp. 1090–3.

† *M.T. Zool. Stat. Neapel*, xv. (1902) pp. 487–554 (4 pls.).

‡ *Tom. cit.*, pp. 483–6 (1 fig.).

§ *Arch. f. Naturges.*, lxi. (1903) pp. 237–96 (4 pls.).

than a distinct organ; and the region may extend from around the stomach to the intestine, or may be altogether confined to the latter. He devotes especially attention to the gland embracing the intestine of *Microcosmus vulgaris* Heller, an interesting organ which seems in many respects comparable to the pancreas of higher vertebrates.

**New Type of Salpa-Chain.\***—J. Bonnier and Ch. Pérez describe a new form *Stephanosalpa polyzona* g. et. sp. n. from the Persian Gulf, which has a wreathed chain (chaîne en guirlandes) quite different in its architectural arrangement from either the *Cyclosalpa* or the *Salpa* type.

## INVERTEBRATA.

### Mollusca.

#### a. Cephalopoda.

**Structure of Ovary in Cephalopods.†**—W. Bergmann describes the ovaries of *Sepia*, *Sepioloa*, *Loligo*, and *Illex* among Decapods, and of *Eledone* and *Octopus* among Octopods. The octopod ovary differs essentially from that of decapods since the secondary body-cavity in the former is so degenerate that it merely forms a capsule for the gonad. Moreover, the octopods have paired oviducts, while the decapods have only one. The author notes, *inter alia*, that the differentiation of ova or of sex in the gonads of *Sepia* does not occur early, and that he has observed in *Loligo vulgaris* a case of binuclear ovum.

**Oxidising Ferments in Ink of Cuttlefishes.‡**—C. Gessard finds that cuttlefishes make their ink by a biochemical process similar to that by which the fungus *Russula nigricans* Bull makes its black. In both there is a ferment—tyrosinase—which acts on tyrosin and produces a black substance. As Bertrand has maintained that tyrosinase in Fungi is always accompanied by laccase, Gessard has sought for the latter in cuttlefishes. He extends Bertrand's conclusion and finds evidence of yet a third oxidising ferment in connection with the ink-making.

**Nervous System of Nautilus.§**—Ch. Gravier has endeavoured to fill some of the gaps in our knowledge of the nervous system of the Pearly Nautilus. He has found, for instance, an anal commissure (suspected by Graham Kerr), and he compares it with that in Chitonidæ. A very good figure is given.

#### γ. Gastropoda.

**Locomotion of Slugs.||**—K. Künkel corroborates some of Simroth's observations, e.g. that species of *Arion* are sluggish and slow in comparison with species of *Limax*. He has also made a number of interesting experiments, which lead him to the following conclusions. (1) The wave-play lasts for some time in the foot of decapitated slugs, and may be seen even on excised pieces. As Simroth pointed out, this is due to the fact that "the ganglia in the meshwork of the pedal musculature are sympathetic and the wave-play is automatic." (2) When the wave-play has stopped in individual pieces it may be set agoing

\* Comptes Rendus, cxxxvi. (1903) pp. 621-2.

† Arch. f. Naturges., lxix. (1903) pp. 227-36 (1 pl. and 1 fig.).

‡ Comptes Rendus, cxxxvi. (1903) pp. 631-2.

§ Tom. cit., pp. 618-21 (1 fig.). || Zool. Anzeig., xxvi. (1903) pp. 560-6.

again by mechanical and light-stimuli. There must be connections between the integumentary nerve-cells and the ganglia in the pedal nerve-network. (3) In pieces of *Arion* mechanical stimuli induced energetic contraction, while luminous stimuli induced the wave-play. (4) Pieces of *Limax* showed stronger "waves" than pieces of *Arion*; as Simroth showed, the pedal nerve-network in the former has many transverse commissures which do not occur in the latter. (5) Median pieces have less power of movement than the head- and tail-pieces. (6) Fragments of head- and tail-pieces can move even more quickly than intact animals. (7) Young specimens of *Limax* move more quickly than the adults.

**Entosiphon Deimatis Parasitic in an Abyssal Holothuroid.\***—R. Koehler and C. Vaney found this new parasite in *Deima blakei* Théel. They describe the structure which resembles in many ways that of *Entocolax*, two important differences being the retention in *Entosiphon* of a spirally twisted visceral mass and of a relatively complex nervous system. Moreover, while *Entocolax* is known only as female, *Entosiphon* is hermaphrodite like *Entoconcha*. And *Entosiphon* has more intimate parasitic relations with its host than *Entocolax* has.

The new form should be placed along with *Mucronalia* and *Stylifer*, and probably *Entocolax*, in the family Eulimidæ. Here also the author would place *Entoconcha*. Some attention is paid to the "pseudopallium," which seems to be a cephalic expansion on the upper region of the proboscis.

**Structure of Pontiothauma.†**—S. Pace gives a partial description of *P. mirabile* E. A. Smith and *P. abyssicola* E. A. Smith, of which only the type-specimens are known. It seems that the affinities of *Pontiothauma* are with the Mangiliinæ, and that its nearest allies are *Pleurotomella* Verrill and *Spergo* Dall.

**Memoir on the Limpet.‡**—J. R. Ainsworth Davis and H. J. Fleure have written the tenth memoir of the Liverpool Marine Biology Committee's useful series. The subject is the common limpet (*Patella vulgata*) and the chief objects of the memoir are to provide a reliable account of the structure of this Gastropod, and to show the place which it occupies in the class to which it belongs.

The matter which the authors believe to be new includes the following chief points:—(1) a lateral glandular streak has been found along each side of the foot of young specimens, resembling that found in *Nacella* and its allies; (2) a muscular zone, named "the internal pallial muscle," has been found extending in the mantle between the tips of the shell-muscle; (3) the structure of the crop and inferences drawn therefrom as to the special torsion of the viscera of *Docoglossa* during consolidation of the visceral hump; (4) the respiratory function of the nuchal cavity as regards damp air; (5) discussion of the evolution of the present topographical relations of rectum, kidneys, pericardium, and

\* *Rev. Suisse Zool.*, xi. (1903) pp. 23–41 (1 pl.).

† *Journ. Linn. Soc. (Zool.)*, xxviii. (1903) pp. 455–62 (1 pl.).

‡ *L. M. B. C. Memoirs*, x. (1903) 76 pp. (4 pls.).

heart; and (6) details of mantle innervation and pallial tentacles. We have used the memoir in an advanced class and have found it most serviceable.

**Function of Subradular Organ in Chiton.\***—H. Heath has made observations on the protrusion and use of the subradular organ in *Cryptochiton stelleri*. The organ in question is situated at the bottom of the subradular sheath formed by the backward prolongation of the hinder wall of the mouth-cavity. It is a bilobed structure that has been aptly compared to two beans with their concave surfaces in contact. Its outer layer, bounding the mouth-cavity, consists of the buccal epithelium modified at this point into high and ciliated columnar cells, usually pigmented and differentiated into sensory and supporting cells. The remaining portions of the organ consist of numerous muscle and connective-tissue fibres, that in addition to their other functions afford lodgment for the relatively well-developed subradular ganglia.

From the observations, it appears that the food and probably the nature of the object on which the animal rests is determined by tactile, and perhaps olfactory organs situated on the proboscis; while the subradular organ is a structure used exclusively for testing the character of the food, in all likelihood *gustatory* in function.

**Follicular Cells in Gonads of Gastropods.†**—C. de Bruyne shows that in Prosobranchs the structure of the gonads in the two sexes is absolutely parallel. In both, there are follicular cells, of homologous structure, which fill a nutritive rôle and serve also for protection or fixation. These follicular cells, like the spermatogonia and oogonia, arise from an "indifferent" germinative tissue. The nutritive or follicular cells, in *Paludina* for instance, have the same origin as the distinctive sex-cells. The same is true of the hermaphrodite Pulmonates. "The follicular cells are neither abortive sex-cells, nor ancestors of the ova and spermatozoa, nor residual elements; they are constituent elements of the gonads which have a vegetative,—and perhaps mechanical rôle."

**Aëriferous Canal in Shell of certain Pulmonata.‡**—A. Bavay directs attention to the presence in small Cyclophoridae (allied to *Opisthoporus*, *Spiraculum*, and *Alycaeus*) of an aëriferous canal *within the shell*, opening internally, but not externally.

**Synopsis of Palæarctic Forms of Clausilia.§**—C. A. Westerlund has studied the numerous forms of this type of snail. His general heading runs:—Cl. I. Malacozoa Cephalophora. Order I. Inoperculata. Section 1, Monotrema. Subsection 2, Gnathophora. Family Helicidae. Subfamily 2, Pupina. The type *Clausilia* includes *Balea* Prid., *Clausilia* Drap., *Laminifera* Btg., and *Serrulina* Mss. The strict genus *Clausilia* includes 33 subgenera!

\* Anat. Anzeig., xxiii. (1903) pp. 92-5 (4 figs.).

† Bull. Classe d. Sciences Acad. Belg., 1903, pp. 115-35.

‡ Bull. Soc. Zool. France, xxviii. (1903) pp. 140-3.

§ Mém. Acad. Imp. Sci. St. Pétersbourg, xi. No. 11 (1901, received 1903) pp. xxxvii. and 1-203.

## 5. Lamellibranchiata.

Frequency of Occurrence of Pearls.\*—W. C. M'Intosh directs attention to the irregularity in frequency of occurrence of pearls in mussels, &c. In one lot one in a hundred may contain a marketable pearl, in another lot 50 p.c. may have pearls of a kind, and so on. In 700 specimens of *Mytilus edulis* from the estuary of the Eden, examined by Mr. A. J. R. Russell, pearls were found in 280 of the 620 large specimens, and 20 in the 80 small specimens. Thus 42.8 p.c. had pearls.

In connection with Dr. Lyster Jameson's view that eider duck and scoter may be the final hosts of the parasites which form the nuclei of the pearls, it is noted that both these birds occur in considerable numbers in the estuary of the Eden and feed on the mussels. It is suggested that some other birds frequenting the mussel-beds, such as the oyster-catcher, may be found to harbour the same parasite.

Brackish Water Cockles.†—N. Andrusoff finds that the number of distinct genera is greater than has hitherto been recognised. He gives diagnoses and descriptions of *Adena* (4 species), *Didena* (3 groups), *Arcicardium* (4 species), *Plagiodena* g. n. (5 species), *Phylliocardium*, *Monodena* (14 species), *Limnocardium*, *Mycocardia*, *Uniocardium*, *Prosdena* (17 species), *Stylodena*, *Horiodena*, and *Budmania*.

## Arthropoda.

## a. Insecta.

Phylogeny of *Carabus*.‡—G. de Lapouge has made a detailed study of this, dealing especially with *Carabus violaceus*, the typical form of which is the extreme result of convergent evolution from at least three sources, Iberian, Italian, and Balkan.

Post-embryonic Development of Intestine.§—P. Deegener has studied this in *Cybister roeselii* Curtis from the time when the larva leaves the water and begins to pupate in the earth. It is necessary to distinguish (1) the mid-gut epithelium which functions during the last larval stage (apparently *without* a "Stäbchensaum"); (2) the "Kryptenhals" cells which are not functional, but form the transition to (3) the crypt-cells or proper regeneration-cells in the fundus of the crypts, structurally and functionally indifferent elements which form the epithelium of the pupal intestine, and along with their descendants the imaginal epithelium also.

The larval epithelium is separated off and disintegrated; the Kryptenhals-epithelium is provisional and soon perishes; it is succeeded by the regeneration-cells which form a pupal epithelium (*with* "Stäbchenbesatz"); this again is moulted off and succeeded by a quite new imaginal epithelium.

Variations of *Pieris napi*.||—Fr. Wagner discusses the validity of the *sulphurea*, *sulphureotincta* and *flavescens* varieties of this common

\* Ann. Nat. Hist., xi. (1903) pp. 549-51.

† Mém. Acad. Imp. Sci. St. Pétersbourg, xiii. No. 3 (1903) pp. 1-82 (7 pls. and 5 figs.).

‡ Travaux Scientifiques Univ. Rennes, i. (1902) pp. 79-98.

§ Zool. Anzeig., xxvi. (1903) pp. 547-50.

|| Verh. Zool.-bot. Ges. Wien, liii. (1903) pp. 174-8 (1 pl.).

butterfly, and his study of this case of specific variation is illustrated by an excellent plate.

**New Case of Protective Mimicry in a Caterpillar.\***—R. Shelford describes a remarkable case. On a *Spiraea*-like plant, collected at Sarawak, which bore numerous pale green cymose inflorescences still in bud, what looked like one of the branchlets was seen to be moving. This was a small Geometer caterpillar, only 9 mm. in length, covered with buds from the inflorescence on which it was feeding. Strings of buds, connected by silk, were fastened to spine-like processes on the body, and when the green buds faded or were removed, they were immediately replaced by fresh ones. The mode of fixation is described. The larva fed on the buds, scooping out the interior, and, when not hurried, used empty shells in preference to whole buds for its covering. When irritated, the caterpillar curled up and remained stationary for 15–20 minutes so that its burden of buds seemed, as the sketch shows, to form part of the entourage of living buds. At other times it would sway about, looking like a branchlet blown by the breeze. As is frequently the case with specially protected insects, the species seems to be rare, and the perfect insect is not yet known.

**Notes on Seasonal Dimorphism.†**—F. A. Dixey, in an account of Lepidoptera from the White Nile, shows that in cases where the existence of seasonal modification has been reasonably presumed, or even actually demonstrated, the seasonal relation is far from being rigidly fixed. Thus he notes (*a*) the persistence of dry-season coloration in the females of seasonally dimorphic species; and (*b*) the simultaneous occurrence of diverse seasonal forms.

**Artificial Parthenogenesis in Silk Moth.‡**—A. Tichomiroff refers to his experiments made in 1885 which showed that very varied stimuli—sulphuric acid, friction, warm water—might induce artificial parthenogenesis in the eggs of the silk-moth. He has made further experiments, and finds that the parthenogenetic development always shows more or less abnormality. The cells of the serosa are sometimes gigantic and they sometimes lie in an irregular chain in the middle of the yolk, the ectoderm sometimes grows much more rapidly than the other layers, and sometimes it lags behind. In short the development is not normal.

**Development of Stylopidae.§**—C. T. Brues has studied three North American species of *Xenos*, which live as internal parasites of wasps, notably of *Polistes*. The behaviour of styloped wasps towards their parasites is usually friendly, although it is probable that the males are attacked by the wasps whenever they attempt to copulate with the females. Their distribution and occurrence are erratic; due apparently to the fact that as “triungulins” they do not readily become transferred from one wasp to another and consequently to other nests. Large numbers of larvae are often found in one *Polistes* larva, without greatly

\* Nature, lxxviii. (1903) pp. 187–8 (1 fig.). See Zoologist, May 1903.

† Trans. Entomol. Soc. London, 1903, pp. 141–63 (1 pl.).

‡ MT. Com. f. Seidenzucht k. Moskauer Landwirt. Ges., Bd. i. Hft. 10 (1903) pp. 3–10 (1 pl.) (Russian). See Zool. Centralbl., x. (1903) pp. 344–5.

§ Zool. Jahrb., xviii. (1903) pp. 241–70 (2 pls. and 3 figs.).



disturbing the health of the host. The wasps die soon after the emergence of the male *Xenos*, seeming to become dried up. Infected wasps are usually lighter in colour and more feeble in flight.

Oogenesis is very peculiar. Very small larvæ show strings of spherical primitive ova on each side of the gut. These grow and later break up, giving rise to eggs, each of which consists of a mass of nurse-cells bearing a polar cap of cells derived from a primitive egg attached to it. Yolk is formed from the contents of each egg, and when ripe the eggs are scattered about all through the cavity of the body, and lie imbedded in the fatty body. Maturation seems to occur through the fusion of the second polar body with the pronucleus of the egg (!)

The cleavage cells form a blastoderm which does not cover the whole egg, and draws up to one pole to form the rudiment of the germ band by a rearrangement and multiplication of its cells. Older embryos are of the usual generalised type, but on account of their length are curled up in the egg in a peculiar manner.

The first larval stage, or "*triungulin*," gives rise through the loss of its legs and degeneration of its internal organs, to the second or legless larva, which is provided with median metameric protuberances in the place of legs. The sexes begin to differ in external form after another moult when peculiar asymmetrical muscles develop in the thoracic segments. After another ecdysis the adult form appears. The female protrudes the anterior extremity of her body, and lies with her ventral side turned towards the dorsal surface of the wasp's body. The embryological data do not indicate any affinities between the Stylopidae and the Coleoptera, so the family may best be considered for the present as belonging to the Strepsiptera.

The attacks of the parasites are not confined to the female sex; and the sex of the host is at most only to a slight degree influenced by the presence of *Xenos* larvæ in the body. On the other hand, there is a well-marked tendency for all the parasites in one wasp to develop the same sex.

**Lepidoptera of North America.\***—Harrison G. Dyar has accomplished the gigantic task of producing a new list of North American Lepidoptera, with a key to the literature of this order of insects. He has been especially assisted by C. H. Fernald, the late Rev. G. D. Hulst, and A. Busck. The work is intended to take the place of Smith's List (1891), and to furnish a condensed catalogue comparable to Staudinger and Rebel's catalogue of the Lepidoptera of Europe. The author places the butterflies first, since they seem on the whole "higher" than the moths. He follows with the Sphingidae and Saturnians for the same reason, although, in venation, they are more generalised than some of the Noctuid groups. The list, as a whole, proceeds from higher to lower forms, as in Staudinger and Rebel's catalogue.

**Mandibular Glands of Larval Lepidoptera.†**—L. Bordas describes these in *Acherontia atropos*, *Pieris brassicae*, and *Stauropus fagi*,—a pair of tubular glands in the anterior thoracic region, on each side of the

\* Bull. U.S. Nat. Mus., No. 52, 1902, pp. xix. and 723.

† Comptes Rendus, cxxxvi. (1903) pp. 1273-5.

oesophagus, opening on the internal surface of the base of the mandibles. The secretion has a strong odour, and is probably of protective value.

**Oogenesis in Lepidoptera.\***—K. Grünberg finds that in *Bombyx mori* and *Pieris brassicæ* the differentiation of the cellular elements of the ovary occurs during the larval period. The oogonia, which are derived from the primitive germ-cells, produce only oocytes and nutritive cells. The epithelium of the stalk of the ovarioles is formed from small nuclei which are seen in early stages behind the primitive ovarian tubules. After the differentiation of germ-cells has set in, the epithelium of the stalk of the ovarioles forms follicle-cells. Thus germ-cells and follicle-cells have a separate origin, and the latter are genetically equivalent to the cells of the efferent canal.

### β. Myriopoda.

**New Clasping-Organ in a Centipede.†**—R. I. Pocock has described in certain species of the neotropical genus *Parotostigmus* a pair of movable—apparently sexual—processes arising one on each side from the inner surface of the femur of the legs of the posterior pair. In an Ecuador species there are very distinct claspers. These take the form of a stout slightly incurved process jutting backwards from the inferior angle of the coxa of each of the legs of the twentieth pair, and reaching to about the middle of the sternal plate of the twenty-first leg-bearing somite.

Four distinct kinds of secondary sexual characters are now known in the males of *Parotostigmus*: the femoral process of the anal legs, the coxal claspers above referred to, the modification of the last tergal plate in *P. caudatus*, and the modification of the tibial segment of the anal leg in *P. tibialis* Bröl. It is significant that the claspers may be correlated with the femoral processes, but the two other male features exist independently of the femoral processes, and functionally replace them. The only other genus of Scolopendridæ in which similar femoral processes have been described is the remarkable African form *Alipes* (*Eucorybas*), and there are probably affinities between the two genera,—a view quite in keeping with the faunistic similarities that obtain in other respects between tropical Africa and South America.

### δ. Arachnida.

**Irish Fresh-water Mites.‡**—J. N. Halbert notes that most of these agree in their characteristics with common and widely distributed species. Yet interesting forms occur which are little known, while a few are new to science. He proceeds to describe certain of these uncommon species: *Hydrachna incisa* sp. n., *H. dissimilis* sp. n., *H. biscutata* Thor., *Arrhenurus freemani* sp. n., *A. ornatus* George, *A. dilatatus* sp. n., *A. affinis* Koenike, and *A. sculptus* sp. n.

**Species of Ixodidæ.§**—L. G. Neumann, speaking *ex cathedra* as a specialist on mites, points some useful morals to species-mongers. He

\* Zeitschr. f. wiss. Zool., lxxiv. (1903) pp. 327-95 (3 pls.).

† Ann. Nat. Hist., xi. (1903) pp. 621-4 (1 fig.).

‡ Zool. Anzeig., xxvi. (1903) pp. 265-72 (14 figs.).

§ Mem. Acad. Sci. Toulouse, ser. x. vol. ii. (1902) pp. 329-38.

instances *Hyalomma egyptium* L. to which enthusiastic discoverers of species have given 28 other names! He falls foul of Prof. A. Macalister for an obiter dictum of 1871, and shows up F. Supino for even greater transgressions in 1897.

**Spiders of Germany.\***—W. Bösenberg was able to complete his fine monograph on the spiders of Germany before his death. The fifth and sixth parts are now published, but the author died soon after the appearance of the first.

#### ε. Crustacea.

**New Species of Sergestes.†**—H. J. Hansen describes *Sergestes inermis* sp. n., obtained by Mr. George Murray during the cruise of the 'Oceana' in 1898. It is rather closely allied to *S. robustus* Smith, but seems quite distinct.

**New Genus of Copepod.‡**—W. G. Ridewood describes as *Obesiella lyonsiellæ* g. et. sp. n., a new Copepod from the suprabranchial cavities of the deep-sea Lamellibranch *Lyonsiella*. They were so closely packed that the passage of water through the suprabranchial cavities must have been a matter of considerable difficulty. All were females. Their most remarkable feature is the great inflation and loss of external segmentation in the thoracic region, and the reduction in size of the thoracic appendages. The head has the appearance of being provided with a hood, owing to the presence of a dependent flap on each side. There are no eyes. Six pairs of cephalic appendages are present, and four thoracic. The abdomen is indistinctly divided into four segments, the last bearing a pair of caudal rami, short and papilliform, with four or five short setæ. The mouth is extremely small, and set upon the pointed summit of an oral cone, into the conformation of the sides of which the third pair of appendages enter. The genus falls naturally within the family Ascomyzontidæ.

**Note on Phototropism of Daphnia.§**—G. W. Kirkaldy calls attention to H. Schouteden's observations|| which show that *Daphnia magna* exposed to the action of light and able to choose between different intensities, is at first positively phototropic—going towards the zone of greater light, and then—as regards the adults—it gains the zone of less illumination. As to the young individuals, they appear to have tendencies less precise; nevertheless, the positive reaction is maintained in a very great number of cases. Kirkaldy points out that the Belgian zoologist has apparently overlooked the researches of Lubbock¶ upon which considerable light is now thrown.

**Synopsis of British Fresh-water Cladocera.\*\***—D. J. Scourfield has made a useful list of these, with reference to Lilljeborg's monograph of

\* Zoologica, Heft 35 (1903) pp. 385-465 (7 pls.).

† Ann. Nat. Hist., xi. (1903) pp. 479-81 (7 figs.).

‡ Journ. Linn. Soc., xxviii. (1903) pp. 463-5 (2 figs.).

§ Journ. Quekett Micr. Club, 1903, pp. 465-6.

|| Ann. Soc. Entom. Belg., xlvi. (1902) pp. 352-62.

¶ Internat. Sci. Series, lxx., 3rd. ed., 1891, pp. 211-31.

\*\* Journ. Quekett Micr. Club, 1903, pp. 431-54 (1 pl.).

Swedish forms. Of the 96 species recorded from Sweden we have 75 in Britain, or known to occur in Britain, and there are six British species which are not given by Lilljeborg as Swedish. Scourfield gives a clear table showing the general distribution of the British species of Cladocera.

#### Annulata.

**Revision of Annelids of the Cete Region.\***—A. Soulier has begun an arduous task, and gives revised descriptions with synonymy, &c., of *Amphiglene mediterranea*, *Oriu armandi*, *Spirographis spallanzanii*, *Potamilla reniformis*, *Myxicola infundibulum* and *M. aesthetica*, *Pomatoceros triquetus*, *Serpula crater*, *Hydroïles uncinata*, and *Protulu meilhaci*. The precise and terse diagnoses may be of service to those working at this class of Annelids.

**Artificial Parthenogenesis in Egg of Podarke obscura.†**—A. R. Treadwell subjected unfertilised ova of this chaetopod to sea-water plus potassium chloride, and then returned them to normal sea-water. The results were various. Some exhibited "pseudo-cleavage," in which the cytoplasm divided though the nucleus did not. In some cases the chromatin was irregularly diffused, and often a large number of astropheres were seen in the cell. Other ova exhibited both nuclear and cytoplasmic cleavage. But neither the pseudo-cleavages nor the true cleavages followed the typical schema of the normal segmentation. No polar bodies were formed.

Ciliated "embryos" arose after or without true cleavage, and in both cases a prototroch was formed. Coalescence of ova and embryos was observed, but not so markedly as in *Chaetopterus*.

**Phenomena of Fertilisation in Hæmenteria costata.‡**—A. Kowalevsky has added details to his previous account of the remarkable processes of fertilisation in this leech. The male genital aperture does not lead directly to the gonads but into an intermediate cavity into which the spermatophore-sac opens and in which the anterior end of the spermatophore is received. When the spermatophore is introduced into the male aperture, its anterior end perforates the posterior wall of the above-mentioned cavity, and the spermatozoa liberated into the cavity of the body accumulate in the space between the spermatophore-sac, the ovaries, and the "matrix."

When the whole contents of the spermatophore have been liberated, the empty sac is detached from the body and falls off. The spermatozoa are in many cases destroyed by the cells of the nephridial capsules or other phagocytic elements, but a certain number penetrate through the matrix and get into the ovaries.

**Oogenesis and Spermatogenesis in Sagitta bipunctata.§**—N. M. Stevens finds that the points of special interest in the oogenesis of *Sagitta* are: (1) the unbroken continuity of the reduced number of

\* Mém. Acad. Sci. Montpellier, iii. (1902) pp. 109-63 (10 figs.).

† Biol. Bull. Mar. Biol. Lab. Woods Holl, iii. (1902) pp. 235-40 (12 figs.). See Zool. Centralbl., x. (1903) p. 116.

‡ Mém. Acad. Imp. Sci. St. Pétersbourg, xi. No. 10 (1901, received 1903) pp. 19 (1 pl.).

§ Zool. Jahrb., xviii. (1903) pp. 227-40 (2 pls.).

chromosomes during the whole growth-period of the oocytes; (2) the increase in length and the branching of the chromosomes as the oocytes increase in size, and the very great reduction in the size of the chromosomes as the oocytes ripen; (3) the casting out from the nucleus of a large number of what appear to be chromatin-granules, at about the time when the spermatozoon enters the accessory cells; and (4) the connection of each oocyte with two accessory cells, within which is developed a definite path for the spermatozoon from the sperm-duct to the ovum. The spermatogenesis is partially described, and the differences between the author's observations and those of Lee are indicated. The most striking elements among the sperm-cells of *Sagitta* are the cells of the growth-period preceding the two maturation divisions, where the chromosomes appear as nine large, very regular crenate loops.

#### Nematohelminthes.

**Sense-Organs of Ascaris.\***—R. Goldschmidt has made an elaborate study of the sensory structures in *Ascaris lumbricoides* and *A. megalocephala*. These fall into three groups,—the lip-organs, the neck-papillæ, and the anal papillæ. He shows that there is much that is peculiar in the relations between the sensory nerves, the supporting cells, and the conducting cells. As to the functions of the organs we are left almost to supposition. In cases where the organs end beneath the thick cuticle it is very difficult to suggest a function.

#### Platyhelminthes.

**Marine Parasites in Fresh-water Fishes.†**—F. Zschokke has an interesting essay on the occurrence of marine parasites on fresh-water fishes. Thus forms like *Ascaris clavata*, *Echinorhynchus acus*, *Distomum varicum* and *D. appendiculatum*, which are to be regarded as distinctly marine, occur occasionally in fresh-water fishes. A good case is the occurrence of *Scolex polymorphus* in *Cottus gobio*. The author discusses the 31 parasites of *Lota vulgaris* and the 15 of *Silurus glanis*, and shows how they occur in other hosts—fresh-water, marine, and migratory fishes.

**New Case of Dipylidium caninum in Man.‡**—F. Zschokke reports another case of the occurrence of this tapeworm of cat and dog (= *Tenia cucumerina*, *T. elliptica*, &c.) in man. About three dozen cases have been recorded, usually in children, except in Switzerland where four of the six cases were adults. The larval stage occurs in the *Trichodectes canis* (Melnikoff), *Pulex serratus*, and *P. irritans* (Grassi and Rovelli), whence it passes to dog, cat, or man. Prof. M. Braun adds a note of another case from a child in the London Hospital Medical College.

**Drepanidotænia tenuirostris.§**—T. B. Rosseter describes this tapeworm, in regard to which there has been a good deal of vagueness. He obtained it by infecting domestic ducks with cysticeroids, the origin of

\* Zool. Jahrb., xviii. (1903) pp. 1-57 (5 pls.).

† Verh. Nat. Ges. Basel, xvi. (1903) pp. 118-57 (1 pl.).

‡ Centralbl. Bakt. Parasitenkunde, 1<sup>te</sup> Abt., xxxiv. (1903) pp. 42-3.

§ Journ. Quekett Micr. Club, 1903, pp. 399-406 (1 pl.).

which is not stated. The general structure is described with especial attention to the gonads.

**Skin of Trematodes.\***—N. Maclaren has made a fresh study of a subject that has been a good deal discussed. His view of what occurs is as follows. The glandular cells of the original epidermis sink through the basal membrane and beneath the muscular layer. Their secretion, along with a shedding of the ecto-parenchyma, leads to a sloughing and loss of the original epidermis. The secretory process may result in layers, and the innermost layer may form the actual skin of the adult, while the other layers, along with the remains of the original epidermis, form a protective envelope as long as the Trematode lies in the cyst, and are left behind when it leaves the cyst. Most or all of the glandular cells lose their efferent ducts after the definitive sheath is formed.

**Notes on Trematodes.†**—L. Cohn describes *Hoploderma mesocolium* g. et sp. n. from the small intestine of *Draco volans*. It is related to *Dicrocoelium*, but the gonads extend further forwards. He has also found *Amphistomum dolichocotyle* sp. n. in the rectum of *Herpetodryas fuscus*. It is related to *Diplodiscus subclavatus* of the frog.

The author has studied the Laurer-canal and finds that it sometimes serves, as in *Liolope copulans*, for copulation.

**New Distomum from Sawfish Shark.‡**—S. J. Johnston describes *Distomum pristiophori* sp. n., from the body-cavity of *Pristiophorus cirratus*. It has an elongated body, 25 mm. by 6 mm. in breadth, and a very extensible neck. Fastening itself by the ventral sucker, it stretches out its neck for more than an inch, longer than the body itself. The most characteristic features of this new fluke are its size, the character and position of the suckers, the folded but unbranched intestine, the ovoid shape of the ovary and testis and their situation, the great length of the uterus, the grape-like vitelline glands, and the well-developed excretory system. The simple nature of the intestine, the absence of hooks or lobes from the suckers, the almost total obliteration of the cesophagus, and the absence of a retractile telescopic tail-part indicate a position in Dujardin's subgenus *Brachylaimus*, not far from *D. veliporium*.

#### Incertæ Sedis.

**Correct Name of Genus Phoronis.§**—Fr. Poche points out that while Strehll Wright used the term *Phoronis* in 1856, Johannes Müller had described *Actinotrocha branchiata* in 1846. Although Müller only described the larval form, his name *Actinotrocha* should prevail, and the family should be called Actinotrochidæ. What difference it makes we fail to see.

**New Species of Alcyonidium.||**—L. Calvet describes *Alcyonidium brucei* sp. n., collected by Mr. W. S. Bruce from 7–8 fathoms off the Island of Kolgner to the north of Russia. The colony is like a little

\* Zool. Anzeig., xxvi. (1903) pp. 516–24 (6 figs.).

† Centralbl. Bakt. Parasitenkunde, 1<sup>o</sup> Abt., xxxiv. (1903) pp. 38–42 (4 figs.).

‡ Proc. Linn. Soc. N.S.W., xxvii. (1902) pp. 326–30 (1 pl.).

§ Zool. Anzeig., xxvi. (1903) pp. 466–7.

|| Bull. Soc. Zool. France, xxviii. (1903) pp. 33–6 (4 figs.).

cup and the zoeecia are all situated on the convex surface. In this as well as in detailed structure the new species is very distinct.

#### Echinoderma.

**Experimental Studies on Eggs of *Echinus microtuberculatus*.**\*—N. M. Stevens divided the ova in an anaphase of the first cleavage into portions containing fewer than the normal number (18) of chromosomes. A portion with a centrosome and 4–12 chromosomes may divide five or six times without a restoration of the normal number. This is against the conclusion reached by Delage.

Chromosomes may divide repeatedly without spindle formation or the like. Centrosomes may appear *de novo* in a blastomere. Pieces of ovum without indication of the first cleavage plane do not exhibit cell-division unless chromosomes and centrosomes are present.

**Experiments on Ova of Starfish.**†—Jacques Loeb has made some interesting observations on the ova of *Asterias forbesii*. Mature, unfertilised ova soon die a natural death in sterilised sea-water, but immature ova, or those whose maturation has been artificially delayed, or fertilised ova live on for a longer or shorter time. Oxygen and free hydroxyl ions hasten maturation, while scarcity of oxygen inhibits it. In naturally parthenogenetic ova there may be a katalytic substance formed inside the cell, while in eggs which require fertilisation it may have to come from without. The treatment with acids that induces artificial parthenogenesis usually inhibits maturation. Loeb supposes katalytic substances which promote synthetic processes in development, and disruptive antolytic processes in maturation.

#### Cœlentera.

**Development of *Gonionema murbachii*.**‡—H. F. Perkins has studied the development of this species which made a sudden appearance in 1894 in the "eel-pond" at Woods Hole, Mass. His observations show that Haeckel's sharp distinction between Trachomedusæ and Leptomedusæ is not justified.

Dehiscence of sex-cells occurs in *Gonionema* with precise periodicity, and is definitely affected by changes in light. Segmentation is total and equal; the endoderm is formed by delamination of the blastomeres; a solid morula results. A planula stage is followed by a hydrula stage, and during the latter four tentacles are developed.

Youngest medusæ and oldest polyps show marked homologies; and direct metamorphosis is suggested. Peculiar pathological phenomena occur, the larva living for weeks in the form of a plasmodium, with amœbiform activities.

Alternation of generations occurs. A non-sexual form of multiplication takes place during larval life. Buds are produced which are detached as planulæ and go through the same changes as the parent.

The order and arrangement of tentacles in a gonosome follows a

\* Arch. Entwickmech., xv. (1902) pp. 421–8 (1 pl.). See Zool. Centralbl., x. (1903) pp. 416–7.

† Pflüger's Arch. Ges. Physiol., xciii. (1902) pp. 59–76. See Zool. Centralbl., x. (1903) pp. 379–80.

‡ Proc. Acad. Nat. Sci. Philadelphia, liv. (1903) pp. 750–90 (4 pls. and 21 figs.)

definite plan of cyclic sequence, producing a figure which is cyclically, not bilaterally, symmetrical. Tentacles and sense-organs appear at determinate points on the bell-margin. Histogenesis of tentacles and sense-organs shows their homology. The origin of nematocysts from the base of the ectodermal pad at the base of the tentacle is described. Gonads arise as enlargements by proliferation of the ectodermal sub-umbrellar epithelium of the radial canals.

**Hydroids of Pacific Coast of North America.\***—H. B. Torrey gives a table of distribution, a diagnostic key, and a systematic discussion of the hydroids of the Pacific coast of North America. He also discusses in connection with a number of species the relation of form and habit to surroundings, the development and regeneration of tentacles, the problem of orientation, response to tactual stimulation, the origin of branches and gonothecæ within hydrothecæ, and the occurrence of a Haleciid (*Campalecium medusiferum*) with free medusæ.

**Peculiar Structure in Certain Hexacorallia.†**—A. Krempf finds in 25–35 p.c. of individuals of *Seriatopora*, *Stylophora*, and *Pæcilopora*, a peculiar structure—a solid strand, running along the ventral directive mesenteries into the cavity of the body. Morphologically it is an invaginated tentacle, about sixteen times larger than an ordinary tentacle, and also modified in structure. But what its meaning is remains obscure.

#### Porifera.

**Studies on Hexactinellids.‡**—Isao Ijima in his third contribution on this subject describes a new stalked Euplectellid of an interesting structure, which he calls *Placosoma paradictyum*. Its most remarkable feature is the massive development of the body and the differentiation of a part of the external surface into an area, the frontal lattice, more especially adapted to the reception and passing in of the water than other parts of the same.

In observations on the Euplectellidæ generally, Ijima has tried to improve the diagnosis. He makes it read:—"Lyssacine Hexasterophora of tubular, cup-like or massive body; sometimes stalked; either rooted by a tuft of basal spicules or firmly attached by compact base; generally possessing numerous separate oscula. Dermal skeleton composed of hexactinic dermalia, the proximal ray of which is as a rule much longer than any other in the same spicule; no hypodermal pentactins; hexasters various."

The present contribution also contains descriptions of *Leucopsacus orthodocus* Ij., *L. scoliodocus* Ij., *Chaunoplectella cavernosa* Ij., *C. spinifera* sp. n., *Caulophacus rotifolium* sp. n., and *Sympagella anomala* sp. n. These are referred to two families—Leucopsacidæ and Caulophacidæ—newly conceived and proposed for introduction into the system.

**Note on Spongilla fragilis.§**—R. von Lendenfeld took specimens of this fresh-water sponge from the Moldau at Prag and placed them

\* Publications Univ. California (Zool.), i. (1902) pp. 1-104 (11 pls.).

† Comptes Rendus, cxxxvi. (1903) pp. 1210-2.

‡ Journ. Coll. Sci. Imp. Univ. Tokyo, xviii. (1903) pp. 1-124 (8 pls.).

§ Arch. f. Naturges., 69th year, vol. i. (1903) pp. 181-2 (1 pl.).



(October 9, 1902) in an aquarium. Three days later the sponges were dead, but gemmules had attached themselves to the glass walls and were beginning to form new sponges. In twelve days the young sponge grew to a size of 3 cm., and when eighteen days old it had a new generation of gemmules. Microscopical examination showed that these aquarium specimens differed a little from those in the river in respect to the spinose rhabda around the gemmules.

**Siliceous Spicules.\***—G. C. J. Vosmaer endeavours to introduce some improvements in the classification of siliceous sponge spicules. Thus in the group of monaxons, two fundamental divisions may be distinguished, according to the fact whether the ideal axis lies in a plane or not. In the former case the line may be straight, curved, bent, &c.; in the latter case the line is a screw helix (approximately, as all vital structures are). The spicules of the first set are called "*pedinaxons*," those of the second "*spiraxons*." And among the spiraxons we can distinguish two sets:—(a) the screw line is formed on the surface of a circular cylinder ( *$\alpha$ -spiraxons*), or (b) on that of an elliptical cylinder ( *$\beta$ -spiraxons*), of large and small "pitch" respectively. The  *$\alpha$ -spiraxons* include sigmaspira, spirula, spinispira, microspira, and sterrospira-types; the  *$\beta$ -spiraxons* include sigma, chela, and diancistra-types.

#### Protozoa.

**Conjugation of Amœbæ.†**—Margherita T. Mengarini has described what seem to be incontestable cases of the conjugation of two (or even three) small forms (microgametes) of *Amœba undulans* to form a large unit or macrogamete.

**Observations on Acanthometrea.‡**—W. Schewiakoff finds that the acanthin skeleton consists of calcium-aluminium silicate (with traces of iron), and is probably, in life, a hydrate of calcium-aluminium-silicate. This chemical composition makes it clear why there are no fossil remains of Acanthometrea; their fallen skeletons are dissolved in the seawater.

Schewiakoff goes on to discuss the arrangement and fine structure of the contractile elements or myonemes, &c., the changes associated with their contraction and elongation, and the influence of various stimuli—electrical and mechanical—on their excitability.

**Senescence and Conjugation in Infusorians.**—G. Loisel maintains that senescence in an Infusorian implies that in its vital reactions with its environment, an increasing number of protoplasmic molecules are put out of action ("se trouve immobilisé") either temporarily or permanently. Assimilation becomes increasingly difficult and there is a progressive diminution in the power of natural immunisation. Injurious substances, injurious in the widest sense, accumulate and are incompletely neutralised.

On the other hand, conjugation is interpreted as implying a kind of

\* Proc. Section of Sci. k. Akad. Wetenschappen, Amsterdam, v. (1902) pp. 104-14.

† Atti R. Accad. Lincei (Rend.), xii. (1903) pp. 274-82 (4 figs.).

‡ Mém. Acad. Imp. Sci. St. Pétersbourg, xii. No. 10 (1902) pp. 1-40 (4 pls.).

§ Zool. Anzeig., xlv. (1903) pp. 484-95.

protoplasmic purification and a renewal of the power of immunisation. It is antagonistic to senescence, and this idea is extended to the Metazoa as well.

**New Vorticellid.\***—W. Ayrton describes *Zoothamnium geniculatum* sp. n., which he found attached to weeds in the river Waveney, Suffolk. It is an exceedingly beautiful arborescent colony with dimorphic zooids, very like *Z. arbuscula*, but with distinctive features of its own.

**New Species of Trachelomonas.†**—T. Chalkley Palmer describes five new species of this genus, which though apparently not infrequent or wanting in variety, has not been studied with any great degree of enthusiasm. The new forms were obtained from Ancora, New Jersey, in a diatomaceous film. The five species are established solely on the strength of the characters of the lorica, which was in all cases siliceous.

**Trypanosoma found in Sleeping Sickness.‡**—A. Castellani found in the blood and in cerebro-spinal fluid of patients suffering from sleeping sickness, a species of *Trypanosoma* differing from *Tr. gambiense* Dutton in the position of the micronucleus, the vacuole, and the flagellum. Though the structural differences are far from being constant, the author is inclined to think that the form described is a new species. Just as the horse is liable to be infected with *Tr. brucei* ("nagana"), *Tr. evansi* ("surra"), and *Tr. equiperdum* ("dourine"), so man may be attacked by different species giving rise to different diseases.

\* Journ. Quekett Micr. Club, 1903, pp. 407-10 (1 pl.).

† Proc. Acad. Nat. Sci. Philadelphia, 1902, pp. 791-5 (1 pl.).

‡ Brit. Med. Journ., No. 2216, June 20, 1903, pp. 1431-2 (1 fig.).



## BOTANY.

## GENERAL,

Including the Anatomy and Physiology of Seed Plants.

## Cytology,

including Cell-Contents.

Behaviour of the Chromosomes in the Spore-Mother-Cells of Higher Plants.\*—D. M. Mottier has studied nuclear division in the pollen-mother-cells of *Lilium Martagon*, *L. candidum*, *Podophyllum peltatum*, and *Tradescantia virginica*, and those of the corresponding divisions in the embryo-sac mother-cell of *Lilium Martagon*. The details of the successive phases are described in detail. "The first mitosis in both the micro- and macrospore mother-cells of the higher plants is heterotypic, and the second homotypic. These nuclear divisions are not, properly speaking, reducing or reduction divisions. They are not the agents of the reduction, but rather the result of the numerical reduction of the chromosomes." Cytological evidence favours the view that the micro- and macrospore mother-cells are homologous. That type of the embryo-sac in which four potential macrospores are produced as the result of the heterotypic and homotypic mitoses, occurring in Gymnosperms as well as in the majority of Angiosperms, is regarded as the more primitive, while that typified by *Lilium*, where the macrospore mother-cell functions at once as the spore, is to be regarded as a derived condition.

Reconstitution and Formation of Chromosomes in Somatic Nuclei.†—Grégoire and Wygaerts publish a preliminary account of their observations on the minute details of nucleus reconstitution, and the formation of the chromosomes in somatic cells, chiefly meristematic. The authors believe that the resting nucleus is derived from the chromosomes, not by their fusion end to end, but by a gradual process of alveolisation; but in the objects studied the chromosomes retain their individuality even in repose. The chromosomes are formed again by a process exactly opposite to that by which the resting nucleus was formed; they contain no discs or granulations so that when the chromosome splits it simply separates directly into halves.

Behaviour of the Chromosomes of Hybrids.‡—O. Rosenberg has investigated the behaviour of the hybrid *Drosera longifolia* × *rotundifolia* which is found in nature near Tromsö. The number of chromosomes in *D. rotundifolia* is 20 (not 16 as stated earlier by him) in the sporophyte and 10 in the oophyte, while in *D. longifolia* the number is 40 and 20 respectively, just twice as many. In all the vegetative cells of the hybrid 30 chromosomes were found (except in the tapetal cells where a few nuclei with about 40 chromosomes were observed). The spindle figure was somewhat broader than that of *D. rotundifolia*, but

\* Bot. Gazette, xxxv. (1903) pp. 250-82 (4 pls.).

† Beih. z. Bot. Centralbl., xiv. (1903) pp. 13-19.

‡ Ber. Deutsch. Bot. Ges., xxi. (1903) pp. 110-8 (1 pl.).

narrower than that of *D. longifolia*. In the division of the pollen-mother-cells the number of chromosomes was found to vary, for beside the expected number of 15, the numbers 10 and 20, corresponding to those of the parents, were also found, and in fact all three numbers in the same anther. The pollen-grains themselves were also either of hybrid type or else exactly like those of one or other parent. The descendants of these hybrids were not investigated, so that the exact meaning of these important results must at present remain obscure.

**Behaviour of Nuclei in Plant Hybrids.\***—W. A. Cotton has studied the behaviour of the nuclei in the pollen-development of an artificially produced hybrid cotton, *Gossypium barbadense* and *G. herbaceum*. The very early stages were not investigated, but the pollen-mother-cells were seen in the synapsis stage, and the chromatin segments when first observed were in long delicate loops much twisted and bent. The loops thicken to form rings, and then by further condensation lose their ring character, but in the metaphase of the first division this character reappears. In any one nucleus the loops and rings are of uniform size, and the two sizes of rings found in the hybrid pigeon and in some pure forms were not observed. The first division was normally heterotypic, but it could not be determined whether the split at the metaphase separated chromosomes which correspond to the halves of the heterotype ring or whether the split followed the second cleavage. The second division was normally homotypic but could not be studied in detail. Besides the normal divisions, a certain number of abnormal ones were observed, of which details are given. The author believes, however, that the purity of the sex-cells, which is apparently one of the corollaries of Mendel's law, is brought about by the normal tetrad divisions. This point, together with the question of the probable result of hybridity of Cryptogams, is treated of in the earlier part of the paper.

**Non-Sexual Nuclear Fusions.†**—Němec discusses the question of these fusions in relation to the work of his pupil, Blazěk, who found that when the roots of seedlings of *Pisum sativum* and *Vicia Faba* were exposed to vapour of benzene or to a 1 per cent. solution of copper sulphate, multinucleate cells were produced which afterwards became uninucleate by nuclear fusion. These fusions are, of course, not connected with sex (neither are the fusions found in the endosperm of *Corydalis* and *Tulipa*) and Němec believes that they are brought about by an auto-regulating mechanism of the cell which reduces typical cells to the uninucleate state when by any means they have become multinucleate. The author suggests that the morphological characteristic of sex lies rather in cell fusion than in nuclear fusion since the latter power is possessed also by vegetative cells.

**Relationship of the Nuclear Membrane to the Protoplast.‡**—A. A. Lawson has studied the formation of the nuclear membrane especially in the spore-mother-cells of *Passiflora caerulea* and the archeosporial cells of *Equisetum limosum*. His results, which were confirmed

\* Bull. Torrey Bot. Club, xxx. (1903) pp. 133-72 (2 pls.).

† S.B. k. Böhm. Ges. Wissensch., 1902 (1903) pp. 59 (6 pls.).

‡ Bot. Gazette, xxxv. (1903) pp. 305-19 (1 pl.).

by observations on other plants such as *Lilium*, *Cobaea*, *Gladiolus*, *Pinus*, *Pteris*, &c., are as follows. The typical nucleus of the higher plants is a water-cavity, structurally similar to that of the cell-vacuole. The chromatin is the only permanent constituent of the nucleus; the karyolymph, linin, nucleoli, and membrane are renewed with each succeeding mitosis. The nuclear membrane originates like the tonoplast. It is formed by the cytoplasm coming in contact with the karyolymph just as the tonoplast is formed by the cytoplasm coming in contact with the cell-sap. The karyolymph is no more permanent than the cell-sap, and the nuclear membrane is no more permanent than the tonoplast. As the nuclear membrane is of cytoplasmic origin, it is regarded as the inner limiting membrane of cytoplasm rather than as a constituent of the nucleus. Although the chromatin granules found in the cells of the Cyanophyceæ and bacteria are surrounded by neither karyolymph nor membrane, these granules nevertheless represent the nucleus, since every highly organised nucleus passes through a stage in its development when it consists of nothing but chromatin. It is further suggested that the primitive nucleus probably did not secrete a karyolymph, and therefore no nuclear membrane was formed.

**Effect of Temperature on Growing Cells.\***—F. R. Schrammen, following Hobbes who investigated the effect of temperature on the cells of the root-apex of *Vicia Faba*, has made parallel observations on the stem-apex of that plant. His experiments confirm the physiological and morphological distinction of the cytoplasm into tropoplasm and kinoplasm, for these two cell-constituents have a different maximum and minimum for their action and probably a different optimum. His observations point to the spindle-fibres being, not mere lines of force or paths of movement for the chromosomes, but definite threads of considerable rigidity which are able to actively move the chromosomes. The behaviour of the nucleolus points to its being a body of reserve material, chiefly kinoplasmatic. Divisions of an apparent amitotic nature were often observed, these were really the effect of unsuitable temperatures on actual karyokinesis. Another abnormal result of high and low temperatures was to cause the nuclei of some cells to become pressed through the fine pores in the wall.

**Structure of the Starch-Grain.†**—H. Kraemer concludes that the starch-grain consists of colloidal and crystalloidal substances arranged for the most part in distinct lamellæ. At the point of origin of growth, and in the alternate lamellæ, the colloidal predominates associated with the crystalloid cellulose, whereas in the other layers the crystalloidal substance, consisting for the most part of granulose, preponderates. The peculiar behaviour of the colloidal layers towards anilin-stains is analogous to the behaviour of a section containing mucilage-cells towards these dyes, the latter being taken up by the mucilage-cells alone. Again, as the characteristics of mucilage-cells are most pronounced in anhydrous media, such as concentrated glycerin, so a similar effect is seen in the starch-grain. The reason that the crystalloidal character of

\* Verhandl. naturhist. Vereins, lix. (1902) pp. 49-95 (1 pl.).

† Bot. Gazette, xxxiv. (1902) pp. 341-54 (1 pl. and figs. in text).

some of the lamellæ is not apparent under natural conditions is probably because the refractive properties of the crystalloid substance so nearly resembles that of the associated colloid. The use of certain reagents causes an imbibition of water by colloidal portions with consequent swelling of the grain, and hence a contrast in refractive power with the more insoluble crystalloid substances.

**Action of Freezing on Plant-Cells.\***—D. Matruchot and M. Molliard, as the result of a long series of experiments, come to the following conclusions. Freezing of plant-cells or tissues causes an attraction of water to the outside of the cell, produced in aquatic plants by freezing of the surrounding liquid, in aerial plants by freezing of the thin layer of water which covers the external surface of the cell-membranes. There results a rapid general exosmosis of water, and not only from the cell-sap but also from the cytoplasm and the nucleus, in the latter cases by a vacuolation of the living matter. In the case of the cytoplasm there is no evident morphological modification, but with the nucleus there results not only a diminution of volume but also profound modifications in texture. The one or more directions in which the water-attracting force acts is indicated by a uni- to multi-polar orientation in the nucleoplasm; the poles are the points at which the water finds easiest outward passage, they are always more watery and therefore less chromatic than the rest of the nucleus. The position of the poles is always in relation to the proximity of a large cytoplasmic vacuole. Plasmolysis effects the same cytoplasmic and nuclear modifications as freezing.

Molisch's theory of death by freezing finds a direct cytological confirmation in the results of these experiments: death by freezing is really death by desiccation.

**Starch-Grains in the Root-Cap of the Onion.†**—G. Husek gives an account of the occurrence, production, and reactions of starch in the root-cap of *Allium Cepa*. He discusses the influence of temperature and light on its formation and also describes the regeneration of the root-cap after cutting off and the development of the leucoplasts.

**Acocantherin: an African Arrow-Poison.‡**—E. S. Faust has isolated a new poisonous alkaloid, *acocantherin*, from the "Shushi" arrow-poison which is prepared from *Acocanthera abyssinica*. It has the formula  $C_{32}H_{50}O_{12}$  and is precipitated in yellow flakes on addition of ether to its alcoholic solution. It is a homologue of ouabain and strophanthin and is possibly dimethyl-ouabain. Its physiological action resembles that of the *Digitalis* alkaloids.

### Structure and Development.

#### Vegetative.

**Foliar Origin of the Stem.§**—Léon Flot concludes that the general plan of organisation at the stem-apex which is found in plants showing

\* 'Modifications produites par le gel dans la structure des cellules végétales.' Paris, 1902, 55 pp. (3 pls.). Extracted from Rev. Gén. Bot., xiv. (1902).

† S.B. k. Böhm. Ges. Wissenssch., xli. (1902) p. 10.

‡ Arch. exp. Path. Pharm., xlviii. pp. 272-81. See also Journ. Chem. Soc., lxxxiv. (1903) i. p. 191.

§ Comptes Rendus, xxxvi. (1903) pp. 774-6.

very different types of structure, supports the theory, which he has previously put before the Academy, as to the foliar nature of the stem. Each leaf-primordium consists of three meristems, an epidermal, a cortical which follows the epidermal, and a vascular. At the leaf-base the three meristems are continuous with those of leaf-primordia above and below and also laterally with those belonging to the same cycle. The stem-segments corresponding to their respective leaf arise by cell-division in the respective vascular meristems.

**Bundle Arrangement in the Petiole and Leaf-Veins in Dicotyledons.\***—M. Col seeks to explain the bundle arrangement in the leaf-stalk and veins. In all leaves of dicotyledons the nerves and stalk show in transverse section an arc of phloem and xylem, either continuous or divided into bundles; in many cases there are also one or several bundles placed above this arc. The upper system may unite by its edges with the sides of the lower arc; the two together constitute a stele. The author suggests that only the bundles of the arc are in a normal position, and they alone correspond to the vascular circle of the stem. The region in which the upper (anterior) bundles are more or less tardily developed, is homologous to the pith of the stem—it is the upper periderm of Van Tieghem in a slightly extended sense. For convenience of description, we can differentiate the bundles placed above the normal lower arc into anterior (or upper) bundles and medullary bundles proper. The author admits, however, that it is impossible to conceive any nomenclature for the foliar bundles which shall embrace and satisfy all the intermediate arrangements.

**Existence of a Pith in the Leaf-Stalk of Phanerogams.†**—M. Bouygues points out that in addition to the three fundamental regions, epidermal meristem, cortical meristem, and vascular meristem, which the researches of Bonnier and Flot have demonstrated in the young leaf, there is also a definite pith. In a young petiole the whole of the vascular meristem is not used up to form the procambium strands. At the base of the petiole there is a clearly defined remainder in the upper surface of the organ above the procambium strands which corresponds by its situation and perhaps also by its origin with the pith of the stem.

In some cases this meristem is separated from the epidermis by a sub-epidermal layer, which does not remain simple. The form of its elements and its radial division suggest its equivalence to the cortical meristem; but this layer early becomes the seat of rapid tangential divisions and gives rise to the supplementary vascular meristem. The question then arises whether this layer is cortical or a part of the normal vascular meristem. The author has in a previous memoir described it as cortical. M. Col ‡ however, on purely anatomical grounds, regards all the sub-epidermal tissues on the upper face, with or without bundles, as equivalent to the pith of the stem, an interpretation which does not agree with the results of M. Bouygues' researches.

**Unipolar Stele in Rootlets of *Trapa*.§**—C. Queva describes the anatomy of the roots of *Trapa natans*. The stele in the main root is

\* Comptes Rendus, cxxxvi. (1903) pp. 516-8. † Tom. cit., pp. 771-4.

‡ See above. § Comptes Rendus, cxxxvi. (1903) pp. 826-7.

tetrapolar, and the rootlets arise normally and are arranged in four rows. Their growth is limited, and they do not branch; they are very slender, measuring scarcely .3 mm. in diameter. While these rootlets show a normal cortical structure, they are remarkable in having an extremely simple stele. It is limited by an evident bundle-sheath and has a regular pericambium, but the wood consists only of a single tracheid in contact with the rhizogenous layer; the rest of the bundle consists of 3 to 10 uniform phloem elements with thin walls. The bundle is thus unipolar, and the rootlet has a bilateral symmetry, the plane of which passes through the axis of the main root.

This is the only known example of a root of a seed-plant with a unipolar bundle. This reopens the question of the morphology of the abnormal roots of *Isoetes* and certain Lycopods, which have been regarded as half-roots or as roots with a bent bipolar bundle. Similarly the rhizophores of *Selaginella* and the appendices of *Stigmaria* may be analogous cases of reduction of the phloem and xylem of a root.

**Anatomy of certain Groups of Caryophyllaceæ.\***—F. Joesting has studied the anatomical structure of the vegetative organs of a number of genera of the following sections of this order:—*Sperguleæ*, *Polycarpeæ*, *Dysphanicæ*, *Scleranthææ*, and *Pteranthææ*. He draws attention to the extraordinarily primitive leaf-structure of the majority of the plants of these groups; a differentiation into palisade- and spongy-parenchyma is shown only in the arrangement, rarely also in the form of the cells. Another very general character is the segmentation of the wood-cylinder by wedges and parenchymatous tissue, especially in the root, but also the stems which show a well-marked growth in thickness. He also notes the segmentation of the whole root by obliteration of the central tissue; this leads in an extreme case (*Telephium Imperati*) to a complete breaking up of the root into five "branches," each of which shows a centric structure and a cork-envelope. The roots of species of *Spergularia*, *Spergula*, *Telephium*, *Polycarpea*, and others show a remarkable secondary formation by means of extrafascicular secondary cambiums.

**Petiolar Glands of *Viburnum Opulus*.†**—M. Thouvenin describes the histology and the relation to the vascular bundle system of the petiole of the small gland-like stipules and the petiolar glands of this species. He discusses the morphology of these structures and suggests that they may represent reduced lateral leaflets of a compound leaf; these leaflets, the anatomy indicates, were sessile and inserted on the rachis by a broad base.

**Modification of Habit by Grafting.‡**—L. Daniel, continuing his investigations on this subject, records the following conclusions. In the case of Composites the grafting of annual parts of herbaceous plants on appropriate herbaceous stocks may modify the period of duration and prolong the flowering season of the graft. The grafting of an herbaceous plant on an annual plant may prolong the life of the latter. Thus *Solanum pubigerum* was grafted on the giant tobacco, an annual in the

\* Beih. Bot. Centralbl. (Original-Arbeit) xii. (1902) pp. 139-80 (2 pls.).

† Rev. Gen. Bot., xv. (1903) pp. 97-103 (6 figs. in text).

‡ Comptes Rendus, cxxxvi. (1903) pp. 1157-9.



French climate. The plants showed vigorous growth after producing flowers and fruit during a considerable portion of the winter. The grafting operation often effects a considerable change in the characters of the graft or the stock, thus enabling the grower to produce flowers or fruits out of the usual season, as well as demonstrating the plasticity of the species under the influence of sudden variations in its environment.

**Experiments on Grafted Plants.\***—L. Daniel also contributes several papers in which he describes the results of his experiments on grafted shoots and plants; his results are important from an economic point of view.

**Abnormal Growths in Woody Plants.†**—J. Esteva gives photographic representations of abnormal development and growth in the trunk of sweet chestnut and poplar, and of a case of fasciation in *Spartium junceum*.

#### Reproductive.

**Development in Piperaceæ.‡**—D. S. Johnson finds no suggestion of the remarkable embryogeny described for *Peperomia* in other genera of the order (*Piper* and *Heckeria*). The development of ovary, ovule, and embryo-sac differ widely in several respects from that found in the related genus *Peperomia*. The ovary is syncarpous and the ovule has two integuments; the archesporial cell gives rise to a tapetal cell and a single megaspore, and from the latter a seven-nucleate embryo-sac arises in the usual way. The antipodals and synergids are long persistent. The embryo in the ripe seed is very small, it is globular and undifferentiated except for a very short suspensor. The endosperm nucleus of *Piper* forms twenty or more free nuclei, and then cell-walls are formed simultaneously about all of them. In *Heckeria* the endosperm-nuclei are separated from the first by cell-walls. In both, as in *Peperomia*, the endosperm is comparatively small in the ripe seed and contains no starch, abundance of which is found in the surrounding perisperm.

The author also studied the germination of the seeds of *Peperomia* and *Heckeria*. The seed-coat is burst by the swelling of the endosperm and embryo; the endosperm protrudes as a sac which continues to surround the embryo until after root and the two cotyledons are differentiated. The root finally pushes out through the endosperm, but the latter remains about the tips of the cotyledons and imbedded in the seed till all the starch of the perisperm is absorbed.

The striking differences in the mode of formation of the endosperm in the three genera show that characters of this kind are often of no value as indications of affinity. The writer still maintains the position that the peculiarities in *Peperomia* are secondary. The case of *Gunnera*, where Schnegg has shown that the embryo-sac contains sixteen or more nuclei, and that the endosperm nucleus is formed by the fusion of eight or ten of these, is probably an independent secondary development.

The writer sees no reason to doubt that *Peperomia* finds its true affinity among the Piperaceæ.

\* Trav. Sci. de l'Univ. de Rennes, i. pp. 57-63, 69-77, 99-102, 343-59, 365-9.

† Bol. Soc. Españ. Hist. Nat., iii. (1903) pp. 150-2 (4 figs.).

‡ Bot. Gazette, xxxiv. (1902) pp. 322-40 (2 pls.).

Perisperm is at present known in the seeds of Piperales, Aristolochiales, Polygonales, Centrospermæ, and Ranales among the Dicotyledons. All of these orders are, as pointed out by Schimper and Lesquereux, old geologically, and may represent branches of a single stock or phylum of the Dicotyledons. The Piperales are probably much more closely related to Polygonales than would appear from the position assigned to them by Engler.

A study of the germination in *Peperomia* and *Heckeria* indicates that the aleurone-containing endosperm of these forms acts as a digesting and absorbing apparatus for transferring the starch stored in the perisperm to the embryo. In several genera of the Cannaceæ, Polygonaceæ, Phytolaccaceæ, Caryophyllaceæ, and others, a thin layer of endosperm separates perisperm and embryo and seems to serve the same function as in *Peperomia* and *Heckeria*. The embryo sporophyte is perhaps everywhere nourished through the gametophyte and not directly by the parent sporophyte.

**Morphological Study of Asclepiadaceæ.**\*—T. C. Frye has studied the floral development and embryogeny in several species of *Asclepias*. He finds that the umbels are terminal and that the parts of the flower appear in centripetal succession, the members of each set arising simultaneously, and there is no confluence of primordia. The stamens and petals arise early from a common ring slightly elevated above the insertion of the other sets; the tube of the corolla seems to be of toral origin. The stamens are remarkable in the development of intercellular spaces; the horn and head are lateral outgrowths from the filament and composed largely of extremely loose tissue; the horn contains no vascular tissue. The top of the "head" formed by fusion of the tips of the carpels, and not the functional stigma, is believed to be homologous with the stigma of normal angiosperms. In general, Corry's account of the formation of the caudicles and corpuscula is corroborated.

The generative cell divides in the normal way near the tube-nucleus; the division occurs before the formation of pollen-tubes. The pollen-tubes from the same pollinium all enter the same ovary; the tube-nucleus gets no further than the upper part of the ovary.

The ovule has one integument, and the nucellus is a single row of cells enclosing the sporogenous row. A single hypodermal archesporial cell forms a row of four megaspores without the formation of a parietal cell. Occasionally there is more than one archesporial cell; in the formation of the megaspores the daughter-cells do not divide simultaneously. The female gametophyte develops normally. Double fertilisation was observed in *Asclepias Cornuti*, one of the male cells fusing with the antipodal polar nucleus; fertilisation may occur before or after the fusion of the polars. A few tracheids were found in the ovules near the antipodal cells.

The oospore rests until the endosperm has become 16-celled or more. The pappus is composed of single-celled uninucleate trichomes; the double wall of the pod originates in the rupture of the parenchymatous tissue within the wall of the carpel.

\* Bot. Gazette, xxxiv. (1902) pp. 389-413 (3 pls.).

**Vegetative Activity in the Carboniferous Epoch.\***—B. Renault cites various cases in proof of the statement that there was formerly a much greater activity in formation of cellular tissue than at present. One instance is found in the organisation of the pollen-grains; those of *Stephanospermum*, *Cordaites*, and other Gymnosperms contain a prothallium of from 8 to 12 cells, while in present day Gymnosperms no more than 3 or 4 are found. This activity was favoured by a remarkable development of the nourishing vascular strands. For instance, the author has shown that the embryo-sac of *Stephanospermum* was surrounded by bundles of tracheids, while the filament of the stamens in *Cordaites* was traversed by an important vascular bundle which formed a branch for each anther.

**Notes on Compositæ.†**—R. Wagner has studied the morphology of the inflorescence in a number of genera of Compositæ.

**Seeds of Inga.‡**—A. Borzi describes the biology of the seed distribution and germination in *Inga Feuillei* and other species of this genus of Leguminosæ.

**Laticiferous Tissue in Flowers of Convolvulacæ.§**—P. Grélot finds three types of this tissue:—(1) Strings of cells placed end to end with suberised membrane and absorbed transverse walls; branchings occur. These are very regularly distributed, accompanying the nerves in calyx, corolla, and stamen, and localised at the periphery in the ovary and style. (2) Isolated cells, with suberised membrane coexisting with (1) (*Convolvulus Cneorum*), or occurring alone with no precise localisation. (3) Cells fusing to form branched or simple cell-groups; membrane of cellulose. These are the rarest and occur in *Falkia* and *Dichondra*. They are generally subepidermal and have a scattered distribution in the calyx, but are localised at the base of the corolla and pistil. The author finds that the laticiferous tissue does not afford constant characters for distinguishing species of a genus.

### Physiology.

#### Nutrition and Growth.

**Synthesis of Proteids by Plants.||**—Em. Laurent and Em. Marchal divide their paper into two parts. In the first, which is historical, the sources of plant nitrogen, their assimilation by the plant, and the products of assimilation are considered from the point of view of previous work. In the second part the experiments made by the authors are described. Seedlings of mustard and cress, shoots of onion, asparagus, white mustard, leaves of *Nicotiana* and *Syringa* were among the subjects of investigation. The following conclusions are tabulated. Free nitrogen is assimilated by lower organisms:—*Clostridium Pasteurianum*, different species of Bacteria and Nostoc (?), and *Rhizobium* when culti-

\* Comptes Rendus, cxxvi. (1903) pp. 401-3 (8 figs.).

† Verhandl. k. k. Zool. Bot. Gesell. Wien, liii. (1903) pp. 21-65 (6 figs. in text).

‡ Atti Reale Accad. d. Lincei, Rend. Cl. Sci. fis., &c., xii. (1903) pp. 131-40.

§ 'Recherches sur les laticifères de la fleur des Convolvulacées,' Nancy, 1902, 23 pp. (17 figs.). See also Bot. Centralbl., xcii. (1903) p. 83.

|| Bull. Cl. Sci. Acad. Roy. Belg., 1903, pp. 55-114.

vated with sugar or in symbiosis with vascular plants. Ammoniacal nitrogen is assimilated by non-green lower plants (bacteria, moulds) without the aid of light rays. In green plants the process can take place in light or darkness, in green tissues and in those which have no chlorophyll, but it is more active in the light. Nitric nitrogen can also be assimilated in darkness by lower non-green organisms. In green plants, with some exceptions (germinating seeds provided with reserve material), the assimilation of nitrates is much more intense in green leaves exposed to the light, especially to the more refrangible rays. When free nitrogen, or the nitrogen of ammonia or of nitric acid is assimilated in darkness, there is consumption of hydrocarbonaceous material which supplies the necessary energy for the work of reduction of nitrates and of synthesis. The lower non-green plants can synthesise proteids in the dark; the necessary energy is supplied by organic compounds. In green plants, especially the higher plants, this synthesis takes place only in the light. Nevertheless, amides in limited quantity may be produced in organs without chlorophyll (germinating seeds) in the dark; while a supply of certain amides (asparagin, glutamin) and sugars may be followed by production of proteids in the dark. But in the present state of our knowledge, it seems that the transformation of nitric acid or of ammonia into proteids in an adult higher plant requires the intervention of light.

**Assimilation in Green Plants.\***—G. Pollacci describes the experiments he has made to prove the existence of formic aldehyde in green plants. He finds that this substance is formed in the green parts of plants exposed to sunlight in the presence of carbon dioxide, and that it can be distilled from the macerated leaves. It is not formed in plants which have no chlorophyll (e.g. fungi), nor in green plants kept in darkness, nor in the absence of carbon dioxide. He describes the apparatus and reagents used and cites the writings of other workers at this subject.

The same author † replies to Czapek's criticism (in *Bot. Zeit.*, 1900, p. 153) of his work and claims priority for employing Schiff's reagent (aqueous solution of fuchsin decolorised with sulphurous acid) for experimenting on uninjured living green plants in light and darkness and in the presence and absence of carbonic acid, and on plants which contain no chlorophyll, and for demonstrating what was only surmised previously—that formic aldehyde is a normal product of assimilation in green plants.

**Use of Collodion for Detecting Transpiration.‡**—L. Buscalioni and G. Pollacci have discovered a new method of investigating the transpiration of plants, by applying a solution of collodion to the surface. The film sets hard and remains transparent on a dry surface, but on a moist surface becomes opalescent, thus revealing with great accuracy the points of escape of aqueous vapour from the transpiring tissue. It is a great improvement on the older methods of applying paper impregnated with chloride of palladium and iron or with cobalt chloride, for the paper does not come into absolute contact with the

\* *Atti d. Istit. Bot. Univ. Pavia*, vii. (1902) pp. 1-21 (figs. in text).

† *Tom. cit.*, pp. 101-3.

‡ *Tom. cit.*, pp. 83-95, 127-70 (3 pls.).

plant. Further, the collodion film can usually be stripped off with ease and examined under the Microscope, and *inter alia* it affords a transparent and perfect cast of the epidermal cells, stomata, &c. And as solutions, such as cobalt chloride, can be added to the collodion solution, the moisture of transpiration can also be made to yield colour-reactions. The authors publish the results they have obtained in connection with cuticular and stomatic transpiration, the influence of light and of mechanical strain on the stomatic cells, the influence of drought and of chemical vapours (ether, &c.) on transpiration, the structure of organs of movement and of parts in course of growth, the behaviour of lenticels and hydátodes. A long bibliography is appended.

**Function of Calcium Oxalate in Plant Nutrition.\***—M. Amar, working with various genera of Caryophyllaceæ, finds that the deposits of calcium oxalate crystals become less in quantity as the distance from the blade of the leaf increases, in following the course of the elaborated sap. This suggests that the crystals are formed at the expense of this sap, and are deposited chiefly immediately after its elaboration, in the cells near the assimilating and conducting tissues. The author also shows that when once laid down the crystals remain and are not used up when the plants are removed from the soil and grown in a culture solution which contains no calcium compound; that is to say, the calcium oxalate is merely a product of excretion. By germinating seeds in a similar culture solution seedlings with four or five pairs of leaves were obtained which contained no calcium oxalate.

**Periodicity of Morphological Phenomena in Plants.†**—Under this title Tine Tammes describes a number of observations on the influence exerted by the presence or absence of leaves on the period of growth in length of the internodes, and the presence or absence of leaflets in the growth in length of the intervening portions of the leaf-rhachis. He has also studied the relation of variation or periodicity in certain characters of the leaf and leaflet to the same phenomenon.

#### Irritability.

**Stomata of Cotyledons.‡**—G. B. Traverso has tabulated the results of his observations on the influence of light upon the development of stomata in cotyledons, and deduces the conclusions that the number of both stomata and ordinary cells formed per unit of surface in cotyledons grown in darkness is greater than in those grown in light. But the proportion of stomata to ordinary cells in cotyledons grown in darkness is less than in those grown in light, because in darkness the ordinary cells are multiplied at a greater rate than the stomata. In other words, the percentage of stomata is greater in light than in darkness, though the actual number is less per unit of surface.

**Stalolith Theory of Geotropism.§**—F. Darwin describes experiments made by himself which are confirmatory of this theory, which

\* Comptes Rendus, cxxxvi. (1903) pp. 901-2.

† Verhandl. Kon. Akad. Wetensch. Amsterdam, Sect. 2, Deel ix. No. 5 (1903) pp. iv., 148 (1 pl.).

‡ Atti d. Istit. Bot. Univ. Pavia, vii. (1902) pp. 55-64.

§ Proc. Roy. Soc. lxxi. (1903) pp. 362-73. See also Nature, lxxvii. (1903) pp. 571-2.

explains the stimulus to geotropic movement as caused by the falling of the starch-grains on the cell-walls when an organ is moved from its normal position in relation to gravity. The author, wishing to supplement the evidence supplied by Haberlandt and Němec, devised an ingenious but simple method of experiment. If gravitational sensitiveness is a form of contact-irritability (which must be the case if the pressure of the statoliths on the plasmic membrane is the critical event) then it might be possible to intensify the stimulus by vibration. By applying vibration in a vertical plane to a horizontal seedling, the repeated blows of the starch-grains on the protoplasm should produce a more active geotropic response. This was realised by a tuning-fork; seedlings which had been kept horizontal for from 8 to 10 minutes on a tuning-fork vibrating in a vertical plane showed about 44 per cent. more curvature than the control specimen. The experiment was repeated with vertical specimens exposed to lateral illumination to make sure that the enhanced response was not due to an increase in the general irritability of the seedlings. In this case the curvature of the vibrated plants was only 5 per cent. more than that of control specimens. We may therefore conclude that vibration increases the geotropic reaction but does not materially affect heliotropism; which is what we should expect on the assumption of the truth of the statolith theory.

#### Chemical Changes.

**Hydrogen and Carburetted Hydrogen formed by Plants.\***—G. Pollacci in a preliminary note describes briefly the experiments he has made, and the apparatus he employed to demonstrate the emission of free hydrogen and carburetted hydrogen by green plants during assimilation in sunlight. The evolution of nascent hydrogen he believes to be a potent factor in the formation of formic aldehyde in the assimilating tissues.

**Experiments with Potatoes.†**—E. Bréal finds that when potatoes are kept through the winter  $\text{CO}_2$  and  $\text{NH}_3$  are liberated. Chloroform vapour checks the liberation of  $\text{CO}_2$ , and when the action is prolonged the tuber dies and a nitrogenous liquid is produced. Exposure to cold retards the respiration of the tubers and causes the accumulation of a reducing sugar. The organic nitrogen of potatoes is present partly in an insoluble form and partly as albumin, which coagulates at  $70^\circ$ , and partly as solanine. The tubers contain both nitric acid and ammonia; the former disappears when an ammonium salt is introduced. The tubers produce shoots spontaneously in the spring, but require water to form roots. The separated shoots can be made to grow when supplied with suitable mineral food and potassium humate. Roots living in water absorb ammonium salts, but only in absence of nitrates.

**Prussic Acid in opening Buds of Prunus.‡**—E. Verschaffelt finds in *Prunus Padus* and *P. Laurocerasus* a steadily increasing absolute quantity of HCN-compounds in the shoots growing from the opening

\* Atti d. Istit. Bot. Univ. Pavia, vii. (1902) pp. 97-100.

† Ann. Agron., xxviii. (1902) pp. 545-76. See also Journ. Chem. Soc., lxxxiv. (1903) ii. p. 175. ‡ Proc. k. Akad. Wetensch. Amsterdam, v. (1902) pp. 31-41.

buds. These compounds appear, at any rate in great part, independently of light. The HCN is not drawn directly from the internodes associated with the buds; it remains to be shown whether it is supplied by more distant organs or is formed in the growing twigs out of other substances. It is also doubtful in what form the prussic acid is contained in the growing parts. The fact that it is necessary to macerate the killed organs before the total amount of HCN can be distilled off, suggests the presence of a compound that can be split up by an enzyme. Moreover, as the liquid distilled from etiolated as well as from green shoots has a strong smell of benzaldehyde, it is very probable that these organs also contain glucosides of the amygdalin type.

**Hydrocyanic Acid in Sorghum.\***—H. B. Slade finds that stalks of this grass contained .013–.014 per cent. of hydrocyanic acid. The poison is apparently produced by the action of an enzyme on a glucoside, but the author failed to isolate a glucoside.

**Effects of Chemical Agents on the Starch-converting Power of Taka Diastase.†**—K. F. Kellerman has studied and tabulated the effects of a large number of chemical agents on the action of the diastase prepared from *Eurotium Oryzae*—the Japanese saké ferment. In a preliminary series of experiments it was found that the amounts of starch and diastase being constant, the converting power of the enzyme became more and more rapid with the concentration of the solution of starch, or starch-paste; the solutions varied from 3 p.c., which is rather viscous, to .5 p.c., which is very watery.

**Hydrolysis of Polysaccharides.‡**—Em. Bourquelot classifies the hydrolysable derivatives of dextrose under the following headings: ether oxides, ethers, hexotrioses, and polysaccharides, and points out that for each member of these classes there must be a corresponding enzyme to effect hydrolysis. Hence he concludes that the number of soluble ferments or enzymes must be much greater than is generally supposed. Moreover, the action of the enzyme takes place according to relatively simple laws which by further research may be more definitely tabulated.

**Nomenclature of Enzymes.§**—E. O. von Lippmann suggests that each enzyme should be denoted by a name compounded from the name of the substance which is changed and the name of the substance which is formed. Thus the enzyme which converts starch into maltose should be called “amylo-maltase,” and that which converts maltose into dextrose (glucose) “malto-glucase.” If a shorter name be preferred, the syllable “ase” could be affixed to the product of enzyme-action; thus “maltase” would denote an enzyme by the action of which maltose is produced.

**Changes in Salicin in Plant Nutrition.||**—Th. Weevers finds that the amount of salicin in young buds of *Salix purpurea* at first rapidly

\* Journ. Amer. Chem. Soc., xxv. (1903) pp. 55–9. See also Journ. Chem. Soc., lxxxiv. (1903) ii. p. 233. † Bull. Torrey Bot. Club, xxx. (1903) pp. 56–70.

‡ Comptes Rendus, cxxxvi. (1903) pp. 762–4.

§ Ber. Deutsch. Chem. Ges., xxxvi. (1903) pp. 331–2. See also Journ. Chem. Soc., lxxxiv. (1903) i. p. 304.

|| Proc. k. Akad. Wetensch. Amsterdam, v. (1902) pp. 295–303. See also Journ. Chem. Soc., lxxxiv. (1903) ii. p. 232–3.

decreases, but rapidly increases when assimilation begins. When branches were kept in the dark the new shoots were found to contain more than 7 p.c. of the glucoside, but the amount diminished as the shoots grew. Salicin is found in young leaves developing normally; it disappears for a short time and then reappears. Separated leaves lost 30 p.c. of salicin during the night, but recovered the amount in the daytime. In the case of attached leaves it was found that with the loss of salicin in the leaves during the night there was a gain in amount contained in the bark. These changes in the amount of salicin are accompanied by inverse changes in the amount of the catechol. The author concludes that the decomposition of salicin occurs in every cell, the dextrose migrating towards the green parts, whilst catechol remains in the cell and combines with dextrose coming from cells situated nearer to the bark, to re-form salicin. The amount of catechol corresponds with the decrease in the absolute quantity of salicin.

**Production of Alcohol in Seeds.**\*—T. Takahasi finds that sterilised peas (33 gm. weight) kept in water for 38 days, produced much carbon dioxide and nearly 1 gm. of ethyl-alcohol. Many of the peas retained the power of germinating. The production of alcohol was due to the protoplasm as control experiments showed that zymase was absent.

**Action of Uranium on Plants.**†—O. Loew finds that dilute solutions (·01 p.c.) of uranium nitrate increase the yields of peas and oats, stimulating the production both of straw and seed. Solutions containing ·2 p.c. of the salt proved fatal to young pea-plants in three days.

**Action of Sodium Fluoride and Potassium Iodide and Potassium Ferrocyanide on Plants.**—K. Aso ‡ finds that solutions containing ·05 p.c. of sodium fluoride have a more or less injurious effect on the germinating power of seeds. Growth of shoots of barley and rice was stimulated by solutions containing ·001 p.c. of the salt, but wheat shoots were injured. Peas grown in soil were stimulated by small amounts of the same salt (·001 gm.).

S. Suzuki § finds that dilute solutions of potassium iodide (·006 gm. in 2–3 kilos of soil) increased the growth of peas, both as regard straw and seed. Potassium ferrocyanide in solutions containing only ·0001 p.c. gradually destroyed barley plants.

#### General.

**Poppies and Insect Visitors.**||—F. Plateau has made further experiments on the visits of insects to flowers of *Papaver orientale* from which the petals have been removed. He finds that in such flowers fewer seeds are produced than in normal flowers. This, however, is not due to a diminution in the number of insect visitors in the case of the

\* Bull. Coll. Agric. Tokio Imp. Univ., v. (1902) pp. 243–6. See also Journ. Chem. Soc., tom. cit., p. 170.

† Tom. cit., pp. 173–5. See also Journ. Chem. Soc., tom. cit., p. 173.

‡ Tom. cit., pp. 187–95. See Journ. Chem. Soc., loc. cit.

§ Tom. cit., pp. 199–201 and 203–5. See Journ. Chem. Soc., loc. cit., p. 174.

|| Bull. Cl. Sci. Acad. Roy. Belg., 1902, pp. 657–84 (4 figs. in text).



apetalous flowers, but to the way in which the bee enters the flower. In absence of the petals the insect enters the flower in such a way that it does not carry pollen to the stigmas. The difference in seed product is therefore due to the difference in the efficiency of cross- (in the petalous) and self-pollination (in the apetalous flowers). The author found that the fewer seeds produced in the flowers from which the petals had been removed, had the same germinating power as the seeds of normal flowers.

**Determination of Dominance in the Colour Characters of Hybrids.\***—Correns points out that in determining the dominance, absolute and relative, of colour characters of hybrids the psychological characters have been neglected. According to the well-known law of Fechner, apparent intensity of colour to the eye varies only as the logarithm of the actual intensity (concentration) of colour. It is clear that this would lead to serious error when comparing the relative effect of parents in relation to the colour of a hybrid. In order to reduce such an error as much as possible Correns used various thicknesses of coloured solution with which the colours of the parents and hybrid were compared, so as to obtain a numerical expression of the depth of tint. By this method the question of colour dominance was accurately investigated in *Argemone mexicana* × *A. ochroleuca*, in *Mirabilis Jalapa* × *M. Jalapa* var. *aurea*, and in *Melandrium album* × *M. rubrum*.

**Aristolochiaceæ.†**—L. Montemartini alludes to the different views held by several botanists as to the systematic position of the Aristolochiaceæ; and in order to furnish future students of the group with materials for determining its position with greater certainty he puts on record his researches into the anatomical structure of *Aristolochia* and *Asarum europæum*. His observations of the vegetative organs confirm those of Solereder and of Schellenberg. The reproductive organs he describes in greater detail.

**German Flora.‡**—The report of the Commission embodying new observations and records for the Flora of Germany, 1899–1901, occupies a recent number of the *Berichte* of the German Botanical Society. Th. Schute and K. W. von Dalla Torre are responsible for the portion dealing with seed-plants. The bibliography includes 630 papers arranged alphabetically under the name of the author, and there is also a list of new local records arranged systematically under the plant-name.

**Flora of China.§**—C. H. Wright contributes an elaboration of the orders Hæmodoraceæ, Irideæ, Amaryllideæ, Dioscoreaceæ, and Liliaceæ, to Messrs. Forbes and Hemsley's enumeration of Chinese plants.

**Plants of Lord Howe Island.||**—J. H. Maiden supplies notes on a few plants from this island, including a new species of *Cryptocarya*.

\* Ber. Deutsch. Bot. Ges., xxi. (1903) pp. 133–47.

† Atti d. Istit. Bot. Univ. Pavia, vii. (1902) pp. 229–50 (12 pls.).

‡ Ber. Deutsch. Bot. Ges., xx. Generalvers.-heft, il. (1903) pp. 103–72.

§ Journ. Linn. Soc., xxxvi. (1903) pp. 73–136.

|| Proc. Linn. Soc. New South Wales, xxvii. (1902) pp. 347–51 (1 pl.).

**Forest Destruction in the United States.\***—G. Pinchot supplies notes on forest-destruction, its effects, and the methods of regeneration. The notes are illustrated by an excellent series of photographic reproductions.

**Poisonous Action and Histology of Stem of *Derris uliginosa*.†**—F. B. Power has made a detailed analysis of the stem of this fish-poison. No alkaloid was found in the bark, but a considerable amount of tannin and red colouring matter. A resin was extracted with petroleum, and the toxic effect was found to be due to some constituent of that portion of the resin which is soluble in chloroform and not to the tannin. The portion of the resin insoluble in the chloroform had no toxic effect.

P. E. F. Perrédès ‡ gives a detailed description of the minute anatomy of the stem of the plant.

**Mercerisation of Cotton Fabrics.§**—L. Buscalioni describes the various improvements made upon the process discovered by Mercer in 1845, by which cotton cloth treated with caustic soda becomes semi-transparent and stronger, and absorbs dyes more readily. He then enters into a minute description of the microscopical structure of various cotton fibres, their optical and chemical characters, the effect of mercerisation. The opacity of raw cotton is partly due to the air-cavity in the fibre, and the transparency of mercerised cotton is due to the partial expulsion of the air under the stretching and compression employed in the modern improved processes. A long list of papers bearing on the subject is appended.

## CRYPTOGAMS.

### Pteridophyta.

**Root-Development in *Azolla*.||**—R. G. Leavitt notes some points of difference between results obtained by himself in the development of the root-sheath and cap in *Azolla filiculoides* and *A. caroliniana*, and the description given by Strasburger of the process in the former species. He also describes in detail the development of the root-hairs, the initial cells of which arise within a belt of actively dividing cells, immediately beneath the inner root-cap, not far from the apex. The cell does not elongate much in a direction parallel with the length of the root. As the hairs lengthen they lie at first appressed to the root distending the inner cap. The whole root-cap is finally thrown off through the growth of the lower hairs. Owing to the elongation and transverse division of the cells produced simultaneously with the hair initial, the hairs in each longitudinal row become separated by 2–8 cells.

The superficial layer of the root-trunk in these two species of *Azolla* comprised, apart from the apical cell, four regions, viz. (1) a region of embryonic tissue in which the divisions are equating divisions; (2) a

\* Rep. Smithsonian Inst. for 1901 (1902) pp. 401–4 (4 pls.).

† Wellcome Chem. Research Laboratories, No. 34 (1903) pp. 1–25.

‡ Op. cit., No. 35, 1903, pp. 1–10 (9 pls.).

§ Atti d. Istit. Bot. Univ. Pavia, vii. (1902) pp. 195–227 (2 pls.).

|| Bot. Gazette, xxxiv. (1902) pp. 414–9 (1 pl.).

short zone where the divisions are differentiating divisions, giving rise ultimately to two sorts of members, trichomes and flat or prismatic cells; (3) a more extended belt in which the cells of the second class again undergo equating divisions and elongate; (4) a region of matured and fixed tissue, covering the greater part of the root. An epiblemma with such a complex history is characteristic also of wide ranges of fern-allies and monocotyledons and of Nymphaeaceæ in dicotyledons.

**Stigmaria.\***—H. S. Poole describes a specimen from the coal measures at Stellaston, with an exceptionally well preserved internal structure showing a large number of wedges of vascular tissue. Photographs and a description are given of the transverse section, which is about 21 mm. thick.

**German Pteridophyta.†**—C. Luerssen reports to the Commission on the German Flora upon the literature published in 1899–1901 upon Pteridophyta—43 papers; and gives a classified list of the new varieties, forms, &c., and the new geographical records embodied in this literature.

**North American Pteridophyta.**—W. N. Clute and R. S. Cocks ‡ have drawn up an annotated list of 27 ferns and 8 fern-allies, gathered in Louisiana, together with a short account of the collections which have been made in the State, and of its climate and physical geography.

A. A. Eaton § publishes his twelfth paper on the Equisetaceæ of North America, treating of the sub-genus *Hippochætæ*. A new species, *E. Funstoni*, is described.

E. C. Anthony || publishes some notes on the ferns of the east coast of Florida, consisting chiefly of observations on the habitats, distribution, and modes of growth of the species.

### Bryophyta.

**Ejection of Antherozoids.¶**—F. Cavers describes the explosive discharge of antherozoids to a height of two inches by *Fegatella conica* in bright sunshine, in case of naturally growing plants as well as of laboratory cultures. He sketches the structure of the male receptacle, its air-chambers, antheridial pits and cell-structure, and suggests an explanation of the phenomenon.

C. A. King \*\* observed the same process in case of laboratory specimens in March 1901, and found that moisture alone (spraying the plants) was sufficient inciting cause. He quotes G. J. Peirce's observation of the same phenomenon in *Asterella californica* in 1902, the antherozoids being projected to a height of 6 or 8 in. by the pressure set up by increased turgidity of certain cells of the antheridium and its support.

T. Hensnot †† points out that this phenomenon in *Fegatella* was described long ago by Thuret ‡‡ and recalled by Le Jolis in 1894.

\* Trans. Nova Scotian Inst. Sci., x. (1902) pp. 345-7 (2 pls.).

† Ber. Deutsch. Bot. Ges., xx. (1903) Suppl., pp. 173-182.

‡ Fern Bulletin, xi. (1903) pp. 1-5. § Tom. cit., pp. 7-12.

|| Tom. cit., pp. 21-23.

¶ Ann. Bot., xvii. (1903) pp. 270-74 (figs. in text).

\*\* Torrey; iii. (1903) pp. 60-1. †† Rev. Bryol., xxx (1903) p. 57.

‡‡ Mem. Soc. Sci. Cherbourg, iv. (1856) pp. 216-8.

**Fertilisation and Spore-Ripening in Mosses.\***—A. Grimme has carefully studied the time when fertilisation occurs in a large number of mosses growing in Thuringia and Lower Hesse, and the subsequent period that elapses until the spores are ripe. All previous records, save those of Arnell for Scandinavian species, he finds to be untrustworthy. The maturity of the antheridia and archegonia is attended by certain characteristic appearances which are pointed out. The archegonia persist for a much shorter period than the antheridia; hence a monoicous inflorescence may appear to be unisexual. Self-fertilisation may be prevented by dichogamy; but the author does not believe that cross-fertilisation is of any real advantage to mosses. Sterility is mainly due to the coincidence of dry weather and a dioicous inflorescence. The distribution of antherozoids is brought about by the movements of creeping insects, &c., or by the splash of rain-drops. As to spore-ripeness, the ordinary records are useless and misleading; it varies with the climate. The characters that betoken spore-maturity are pointed out. The detaching of the operculum in herbarium specimens is no satisfactory guide as to the natural time of ripeness. The author supplies a table indicating in parallel columns the exact seasons of fertilisation and of spore-ripening, and the duration of sporogonial development, of 207 Thuringian species; and for comparison he adds the corresponding results obtained by Arnell in Scandinavia, as well as the times of spore-ripeness recorded by Limpricht. The period of inflorescence is short and definite for each given species, usually one to two weeks. 177 of the species were examined by both the author and Arnell: in 109 of these it is found that the period of sporogonial development is longer in Germany than in Scandinavia. The longest time observed in Germany is 24 months (*Grimmia ovata*), and the shortest is 4 months (*Catharinaea tenella*). In the majority of German mosses it approaches two years. Self-fertilisation is the rule in hermaphrodite species; the antheridia and archegonia are mature at the same time and thus tend to make cross-fertilisation impossible.

**Riella.†**—M. A. Howe and L. M. Underwood give a short account of the morphology of the curious aquatic genus *Riella*, which was supposed to be confined to the Mediterranean region until last year when a species from Turkestan was described. Two more new species are described, from Texas and the Canary Islands, raising the total to nine species. Gemmæ were found on the American specimens, and were cultivated to enable their development to be described. An account is also given of the spore-germination of both species.

**Sphærocarpus terrestris.‡**—I. Douin, having noticed several erroneous statements about *Sphærocarpus terrestris* in various descriptive floras, has drawn up a careful and detailed account of the structure and development of the plant, illustrated with a number of figures. He compares it with *Riccia sorocarpa* and other hepatics. He has never found it to be otherwise than dioicous. He describes the nervation, branching, and growth of the thallus, the position of the involucre,

\* Hedwigia, xlii. (1903) pp. 1-75 (1 pl.).

† Bull. Torrey Bot. Club, xxx. (1903) pp. 216-24 (2 pls.).

‡ Rev. Bryol., xxx. (1903) pp. 44-57 (figs. in text).

archegonia, and antheridia, and the distribution of the plant in France. He has never found it to be gemmiparous.

**Irish Hepatics.\***—D. McArdle gives a list of 32 hepatics gathered near Enniscorthy, Co. Wexford.

H. W. Lett† corrects the statement that *Riccia glaucescens* was found for the first time in Ireland in 1902. He possesses specimens collected in Co. Antrim in 1895, in which year their discovery was announced in two periodicals.

**Sphagna of Upper Teesdale.‡**—E. C. Horrell gives a list of 28 species and 81 varieties of Sphagnaceæ collected by him and D. A. Jones, within a radius of three miles, during a month's residence in Upper Teesdale. Notes upon the ten localities searched and the noteworthy species found in them are given. These localities lie in Durham, north-west Yorkshire, and Westmoreland. Forms of the *acutifolium* group and of *S. medium* were abundant, but species of the *subsecundum* and *cuspidatum* groups were scarce.

**Homalia lusitanica.§**—A. Casares-Gil gives a detailed description of the monoicous inflorescence and fructification of this species found by him in February on plants growing near Barcelona.

**Catharinea.||**—Krieger describes *Catharinea longemitrata*, a well-marked new species, characterised by its long tubular calyptra, short seta, small capsule, &c., growing near Königstein. Notes on other species and two new varieties are added.

**Dichodontium.¶**—H. N. Dixon, having carefully examined a number of specimens, is led to the conclusion that he has an almost unbroken series of ten intergrading forms connecting the two species *Dichodontium vellucidum* and *D. flavescens*, however distinct the two extremes may appear to be.

**Anomodon Toccoæ.\*\***—N. C. Kindberg, referring to the group of sterile species reduced to *Anomodon Toccoæ* by E. S. Salmon,†† describes for the first time a fertile sample of the species gathered at Kamoon in the Himalayas.

**British Mosses.‡‡**—J. Stirton publishes descriptions of six new species gathered in Scotland, and adds critical notes on other species and varieties.

W. Ingham §§ gives an account of the mosses and hepatics of Baugh Fell, collected during a tour of two days, and classified according to their rocky habitats.

C. H. Binstead ||| describes how and where he found several rare species in Yorkshire, Scotland, and Ireland. Some critical remarks are interspersed.

\* Irish Naturalist, xii. (1903) pp. 132-4.

† Tom. cit., p. 107.

‡ Journ. Bot., xli. (1903) pp. 180-5.

§ Rev. Bryol., xxx. (1903) pp. 37-39 (figs. in text).

|| Hedwigia, xlii. (1903) Beibl., pp. 118-20 (1 pl.).

¶ Rev. Bryol., xxx. (1903) pp. 39-43.

\*\* Tom. cit., pp. 43, 44.

†† Journ. Bot., xxxix. (1901) p. 360.

‡‡ Ann. Scot. Nat. Hist., 1903, pp. 109-116.

§§ Naturalist, 1903, pp. 79-82.

||| Tom. cit., pp. 113-116.

**German Muscineæ.\***—K. Osterwald reports to the commission on the German Flora upon the literature published in 1899–1901 upon mosses and hepatics—135 papers; and gives alphabetical lists of the new species, varieties, &c., and the new geographical records embodied in the literature quoted.

O. Jaap † in enumerating the cellular cryptogams of Röm Island, North Friesland, quotes 113 mosses and 35 hepatics, with one new species *Bryum romöense*.

**Italian Mosses. ‡**—A. Bottini publishes a list of the pleurocarpous mosses of the Tuscan Archipelago. These are 38 in number; 8 of the varieties are new to Italy and 4 are described for the first time.

**North American Mosses. §**—A. J. Grout describes *Polytrichum Smithia*, a new American species resembling *P. gracile* and *P. Ohioense*; also a new form of *P. commune*.

E. G. Britton || clears up the synonymy of *Hypnum (Stereodon) revolutum*, a subarctic and alpine moss of the old and new world.

J. W. Bailey ¶ gives an interesting list of mosses which are commonly found on *Acer macrophylla*, a large tree plentiful in the Western States. Each of the 17 species mentioned always selects some particular part of the tree, e.g. root, stem or branch, which suits it best.

J. M. Holzinger \*\* shows that certain mosses gathered in Southern France and named *Seligeria tristicha* are referable to *S. tristichoides* Kindb., a plant hitherto known only from Norway and North America. Its European distribution is likely to be extended further.

R. S. Williams †† has made the interesting discovery that *Cedipodium Griffithianum*, a British moss which is known also from Scandinavia and Greenland, occurs in the Alaskan collections of the Harriman Expedition.

J. Cardot and I. Theriot †† described 45 new species and varieties as collected by the Harriman Expedition in Alaska; 18 of the descriptions, with critical notes, are reproduced in the *Bryologist*.

**Moss Flora of Australia. §§**—W. W. Watts and T. Whitelegge, having compiled a catalogue of the mosses of Australia and Tasmania, publish the first part of it—534 species of Sphagnaceæ and Haplolepideous Acrocarpi. All available sources, such as published lists and herbarium records, have been employed; but great difficulty was experienced in dealing with the diverse principles of determination adopted by such authorities as Wilson and Mitten on the one hand and C. Mueller and Brotherus on the other. The question of synonymy was found in several cases to be a matter of great uncertainty.

#### Algæ.

**German Algæ and Peridiniæ. |||**—Lists are published in a Report of the Commission on German Flora, of the Marine Algæ by P.

\* Ber. Deutsch. Bot. Ges., xx. (1903) Suppl., pp. 183–241.

† Schrift. Naturw. Ver. Schles.-Holst., xii. pp. 1–32; Hedwigia, xlii. (1903) Beibl., p. 121. ‡ Bull. Soc. Bot. Ital., 1903, pp. 6–10.

§ Bryologist, vi. (1903) p. 41 (1 pl.). || Tom. cit., pp. 42, 43.

¶ Tom. cit., pp. 44–45. \*\* Tom. cit., p. 47.

†† Tom. cit., p. 47. †† Tom. cit., pp. 48–54.

§§ Proc. Linn. Soc. New South Wales, xxviii. (1902) Suppl., pp. 1–90.

||| Ber. Deutsch. Bot. Ges., xx. (1903) Suppl., pp. 242–63.

Kuckuck, the Fresh-water Algæ by E. Lemmermann, the Bacillariales by B. Schröder, and the Peridinales by E. Lemmermann. The names of the species are given in alphabetical order and are divided into two groups: those new to the district and those worthy of note. The locality of each species is given, and each list is preceded by an enumeration of literature bearing on the subject.

**Morphology and Physiology of *Scenedesmus acutus*.**\*—J. Grintzesco has made a series of experiments on this alga and comes to the following conclusions. The two principal conditions in which it may exist are the Cœnobium and Dactylococcus state, in the latter of which the cells are either free or joined together in chains. The alga flourishes equally well on agar-agar as on gelatin, which latter medium it liquefies. Glucose tends to hasten development for a time only. The alga shows marked polymorphism, especially under certain conditions, and protococcoid forms are often seen in cultures on dishes of porous porcelain. The alga may develop in the dark, but not so speedily as in light. It can also grow in a vacuum, and its limits of temperature may vary from 2°–30°, the optimum lying between 18° and 20°.

**Structure and Life-History of Diatoms.**†—F. R. Rowley gives a full abstract of work published by Lauterborn in 1896, on the protoplasm, nucleus, centrosome, and phenomena attending nuclear and cell division in diatoms. Species of *Surirella*, *Nitzschia*, *Pleurosigma*, *Pinnularia*, *Navicula*, &c. were studied. Pfitzer's results concerning the arrangement of the protoplasm were in the main confirmed, and many bodies, previously regarded as oil-drops, were found to be the "red granules" of Bütschli. The protoplasm was shown under high magnification to be distinctly reticulated, not granular. Short, paired, rod-like bodies ("*Doppelstäbchen*") were seen in certain *Pinnulariæ* to be connected with a plexus of anastomosing fibrils situated between the chromatophore and the cell-membranes, and at the beginning of nuclear division these rods and fibrils exhibit a radial arrangement with respect to the nucleus. In *Surirella* an irregular anastomosing system of fibrils has been observed, but the paired rods of *Pinnularia* have not been seen in *Surirella* except in the initial stage of nuclear division. Some of the fibrils possess the power of independent movement. Similar structures have been observed also in *Bryopsis* and *Spirogyra*.

Chromatophores and pyrenoids are dealt with, and methods are given for showing the difference between oil-drops and "red granules." The paper closes with an account of the various stages of mitosis in *Surirella calcarata*, which Lauterborn regards as a model for other species in the matter of cell-division. Lauterborn holds that diatoms multiply by division rather than by spore-formation, since among the thousands of examples he has examined no trace of spore-formation was observed, while he saw and studied hundreds of dividing cells. This paper is illustrated by 13 figures, 5 of which are in the text.

**Fossil Diatoms of Auvergne.**‡—F. Hériband gives a list of 160 species of fossil diatoms collected from deposits in various parts of

\* Bull. Herb. Boiss., sér. 2, ii. (1902) pp. 217–64, 406–29 (5 pls. and 6 figs.) Hedwigia, xlii. (1903) Beibl., p. 124.

† Journ. Quek. Mier. Club, viii. (1902) pp. 417–50 (pl. 23 and 5 figs. in text).

‡ 'Les Diatomées fossiles d'Auvergne,' Paris, 1902, pp. 79 (2 pls.).

Auvergne. With the exception of a certain number from the Puy de Mur all the species recorded belong to fresh-water. Out of a total of 160, 67 are new to Auvergne and, among those, 39 species and varieties are new to science.

**Lincolnshire Diatoms.\***—A. Smith gives a list of 46 forms representing the diatom flora of Clee near Grimsby.

**Atlantic Plankton.†**—R. N. Rudmose Brown, reporting on the plankton and botany of the 'Scotia's' voyage out to the Falkland Islands, says that Diatomaceæ were usually scarce in the gatherings, but Peridiniae, especially the genera *Ceratium* and *Histioneis*, were plentiful. *Pyrocystis noctiluca* abounded off the coast of Brazil. Some marine algæ were gathered at the islands visited. At St. Paul's Rocks two species of *Caulerpa* were obtained. There were but few opportunities for collecting land-plants.

**Plankton of Lake Nyassa and other Mid-African Lakes.‡**—W. Schmidle publishes the results of Dr. Fülleborn's collection of floating Chlorophyceæ and Cyanophyceæ in several lakes in Central Africa. In the first part of his paper he deals with the topographical conditions of Lake Nyassa, together with a description of the collector's methods of capture. Then he details the specimens found, arranged according to locality, speaks of the composition of the limnoplankton, the influence of the shore-flora on the plankton, that of the Nyassa on the potamoplankton of the Shire, the flora of the bottom of the lake, the vertical and horizontal distribution, the influence of weather and time of day, the quantity of the hauls, and the seasonal distribution. In the second part of the paper the plankton of the following lakes is given for comparison: Victoria Nyanza, Rukuga, Malomba, Ikapo, Chunguru, and the crater lakes Wentzel (Nyozi) and Itende.

**Studies on the Comparative Development of Laminariaceæ.§**—J. Reinke divides his observations into two groups: descriptive and theoretical. In the former, which he prefaces by remarks on the systematic position of the genera *Chorda* and *Adenocystis* with regard to Laminariaceæ, he deals with the development of the genera *Laminaria*, *Saccorhiza*, *Agarum*, *Lessonia*, *Lessoniopsis*—under which new name the author describes *Lessonia litoralis* Farlow—*Nereocystis*, *Macrocystis*, *Alaria*, and *Egregia*. Under *Alaria* are mentioned the allied genera *Ecklonia*, *Ulopteryx*, *Eisenia*, and *Pterygophora*. The author deplors our lack of knowledge as to the germination of spores in this order, and hopes that work may be done on this point, at least for the European species. Another important point in the comparative morphology of Laminariaceæ is the question as to whether the splitting of the thallus takes place in the same manner throughout the order or not. The author is of opinion that the method is the same.

The theoretical part of the paper is divided into "The Laminariaceæ and the phylogenetic problem" and "The Laminariaceæ and Hæckel's 'biogenetic law.'"

\* Naturalist, 1903, p. 122.

† Scot. Geogr. Mag., xix. (1903) pp. 175-6.

‡ Engl. Bot. Jahrb., xxxiii. (1902) pp. 1-33; Hedwigia, xlii. (1903) Beibl., p. 125.

§ Stud. vergl. Entwickl.-Gesch. Laminariaceen, Kiel, 1903, pp. 1-67 (15 figs.).



**Laminariaceæ and Laminaria Industries of Hokkaido, Japan.\***

Kingo Miyabé publishes part iii. of the "Report on the Investigations on the Marine Resources of Hokkaido" under the above title. The first part contains an account of the Laminariaceæ of Hokkaido, dealing with their outer and inner morphology, propagation, distribution, economic uses, injuries caused by other seaweeds and marine animals, and classification. Then follows the systematic part in which 14 plates of species of *Laminaria* are given, of which 8 represent new species. A new genus is described, *Kjellmanniella*, founded on *Laminaria gyrata* Kjellmann, and with this species is associated a new one, *K. crassifolia*. Species are figured of *Arthrothamnus*, *Costaria*, *Alaria*, including several novelties, *Undaria*, *Agarum*, and *Thalassiophyllum*.

The second part of this paper deals with the Laminarian industries of Hokkaido, under the heading of "Laminaria-Beds," collecting, produce, curing, each part being divided in several subdivisions.

A chemical analysis of *Laminaria*, by Kintaro Oshima, and a bibliography complete this work, the text of which is in Japanese.

**Cystoclonium purpurascens and Chordaria flagelliformis.†—**

A. Henckel continues his observations on the anatomy and biology of these two algæ, begun in 1901. In this part of his paper he treats of the morphology and anatomy of *C. flagelliformis*, describes its habit and general characteristics, the mode of growth, and the various tissues, assimilative, conducting, mechanical, &c. The structure is then compared with that of *Cystoclonium purpurascens*, and general deductions are made.

**Schimmelmanna ornata.‡—**A. Mazza discusses the geographical distribution of this species and the possible causes for such distribution. He remarks on its confinement within very narrow areas of coast-line and the distance between these areas. The records of it being so few and its abundance within these limits being so marked, the author suggests that the plant requires certain nutriment only to be obtained in few localities. On the Sicilian coast near Acireale, where it flourishes, there is an abundant flow of fresh water rich in carbonates, especially magnesia; and this is suggested as a possible aid to the development of the plant. It is supposed, from its isolation in this spot, to have been drifted over from the shores of Morocco. Until further data are gathered as to the general requirements and conditions of growth of this alga in its various localities, no definite conclusions can be drawn. The form is described and figured and the reasons given for regarding *S. ornata* as a perennial plant.

**Algæ of North-Western America.§—**W. A. Setchell and N. L. Gardner publish a critical list of the algæ of north-west America, for the most part consisting of marine, but including also a certain number of fresh-water species. The Desmidiaceæ and Diatomaceæ are omitted,

\* Publications Fishery Bureau, Hokkaido Govt., Japan, 1902, 212 pp. and 37 pls.

† Script. Bot. Hort. Univ. Petropol., xix. (1902) 38 pp. (6 pls.); Hedwigia, xlii. (1903) Beibl., p. 124.

‡ Nuov. Notar., xiv. (1903) pp. 45-61 (1 pl.). See also Rend. e Mem. R. Acc. Sci., &c., Acireale, ser. 3, i. No. 6, pp. 6.

§ Univers. Calif. Publ. Bot., i. (1903) pp. 165-418 (pls. 17-27).

but with these two exceptions the object has been so far as possible to include every alga known to occur on the coast or in the coast country from the latitude of Cape Flattery northward to the Arctic Ocean. The authors include also the Aleutian Islands, the Pribilof Islands, and St. Lawrence Island. A list is given of the existing collections from this region, and another of the collections on which this list has been largely founded—material brought together from all parts of the district in question. The north-west coast is divided by the authors into four well-marked regions:—the Boreal, the North Temperate, the North Subtropical, and the Tropical; and an interesting section, Geography, deals with the reasons for thus dividing the district. In the systematic part of this work, certain new species are described and one new genus of Chaetangiaceæ, *Whidbeyella*. An explanatory list of geographical names is given, and the paper is illustrated by eleven plates.

**Marine Algæ of Iceland.\***—H. Jonsson continues his critical list of these algæ with a paper on the Phaeophyceæ of the island. One new species is described, *Ascocyclus islandicus*. The full notes which follow the record of each species give much valuable information, which is supplemented by 25 figures in the text. The first part of this work, dealing with the Rhodophyceæ, was published in 1901, in the same journal.

#### Fungi.

**Proteid Formation in Moulds.†**—F. Czapek ‡ continues his researches on nitrogen assimilation in plants. The present paper deals with the utilisation of nitrates, organic nitro-derivatives, hydrazines, oximes, cyanides and thiocyanates.

*Aspergillus niger* assimilates the nitrogen of inorganic nitrates. Nitro-methane was used, but there was not much growth; methyl-hydrazine gave good results, while phenyl-hydrazine was useless. Acetaldoxime and acetoxime were not utilised. Sodium thiocyanate gave fair results; potassium ferrocyanide gave no growth at all, and potassium ferricyanide and sodium nitroferrocyanide very little. As regards sources of carbon, the hexoses are the best.

**Rennet-like Enzyme from Yeast.§**—R. Rapp has shown that from yeast can be extracted a ferment which curdles milk. As long ago as 1852 Heubner observed that milk could curdle without either the addition of rennet or of an acid. This was shown later to be due to the action of a bacterial enzyme, and now it has been shown that a similar ferment can be obtained from yeast. The behaviour of the enzyme under various conditions was investigated, and especially its resistance to heat; a temperature of 55–57° C. for 25 hours having no effect upon its action.

**Helminthosporium macrocarpum.||**—F. Guéguen found this fungus on a branch of maple. He made successful cultures and followed its

\* Bot. Tidssk., xxv. (1903) pp. 141–195.

† Beitr. Chem. Physiol. Path., iii. (1902) pp. 47–36. See Journ. Chem. Soc., lxxxiv. (1903) ii. p. 168.

‡ See this Journal, 1902, p. 457, and 1903, p. 190.

§ Centralbl. Bakt., ix. (1902) pp. 625–30.

|| Bull. Soc. Mycol. France, xix. (1903) pp. 56–65 (2 pls.).

growth throughout. The conidiophores are usually unbranched and rise from a pseudoparenchymatous mass of hyphæ. The conidia are somewhat pyriform, and germinate readily from each cell. Small masses of mycelium form sclerotium-like bodies which resemble the first stage of the perithecia of *Letendrea eurotioides* of which *H. macrocarpum* is probably the conidial stage.

**Disease of Apples.\***—A disease of the fruits which begins in the core and spreads outwards has been traced by F. Reinitzer to the growth of a fungus *Cephalothecium roseum*. The parts affected become brown and are very bitter. This fungus is only known hitherto as a saprophyte on dead wood, &c.

**Monilia Disease.†**—Karl Schilberszky does not accept the opinion that *M. fructigena* and *M. cinerea* are two distinct species. The morphological and other differences noted are rather those of accommodation by the fungus to the different hosts. The *Sclerotinia* form had not been found when this research was made.

A careful account‡ of the same fungus as found on apples, and advice as to the best methods of combating it are given by the Board of Agriculture. *Monilia* attacks the leaves first where it forms green velvet patches. The spores are washed by rain on to the young fruit where they develop and ruin the fruit.

**Botrytis parasitica.§**—J. Ritzema Bos gives the conclusion of his work on the tulip disease in Holland. He discusses the spread of the disease, recommends the cultivator how to deal with infected soil and gives the results of his experiments with various fungicides.

**Botrytis vulgaris on Figs.||**—This fungus attacks unripe figs; these become mummified and hang on the tree. A. Prunet describes the development of the *Botrytis* and of the sclerotia on the figs. He also found that the branches above and below the diseased fruits were invaded and destroyed by the fungus. Sclerotia were formed on the branches as well as the conidia of the *Botrytis*. The writer recommends plucking the mummified figs to prevent the infection of the branches. The disease has done considerable harm in the south of France.

**New Hyphomycetes.¶**—Morgan found a new member of the Tubulariaceæ, *Sporocystis condita*, growing on old leaves in woods. It is characterised by a large, fleshy, white, subglobose stroma with a dense superficial layer of subglobose, colourless spores.

Roland Thaxter\*\* describes two coprophilous moulds of great interest. *Heterocephalum aurantiacum* gen. et sp. nov. has the appearance of a large *Aspergillus*. The sporophores rise from a swollen head and from their branched ends minute oval spores are abjoined, the whole head is surrounded by a cortex of hyphæ. *Cephalophora* gen. nov. is of

\* Oest. Bot. Zeitschr., lii. (1902) p. 290.

† Magyar bot. lapok, i. (1902) pp. 157-8. See also Centralbl. Bakt., x. (1903) pp. 224-5.

‡ Journ. Board Agric., ix. (1903) pp. 526-7 (1 pl.).

§ Centralbl. Bakt., x. (1903) pp. 89-94.

|| Comptes Rendus, cxxxvi. (1903) pp. 395-7.

¶ Journ. Mycol., viii. (1903) p. 169.

\*\* Bot. Gazette, xxxv. (1903) pp. 153-9 (2 pls.).

a less complicated structure, the fertile hyphæ arise directly from the vegetative mycelium, and form a swollen head on which are seated the septate brownish spores. Thaxter found two species of this genus. These fungi are from tropical regions.

**Ravenelias of the United States and Mexico.\***—William H. Long, junr., groups the species in three genera. *Ravenelia*: All the teleutospores in a head one-celled; æcidia when present have a well-developed pseudoperidium. *Pleoravenelia*: Inner teleutospores in a head two-celled; æcidia as in *Ravenelia*. *Neoravenelia*: Teleutospores one-celled; æcidia without a pseudoperidium. The two latter genera have been established by the writer, and have caused a rearranging of the species already known. There are also a number of species new to science. The genus is tropical or sub-tropical, and with two exceptions the species grow on Leguminosæ. They are distinguished by the glandular appearance of the sori. Long describes the best method of examining and preserving microscopic specimens.

**Notes on Uredineæ.†**—The first of these, by E. W. D. Holway, comprises critical notes on *Puccinia columbiensis*, some confusion having arisen in the determination of the host-plant, and on *P. suffusca*, the name now proposed for *P. Pulsatille* Rostr. The writer gives a detailed account of *P. fusca*, the *Æcidium fuscum* of Persoon.

A new species, *Melampsorella Feurichii*,‡ has been determined by P. Magnus and named after G. Feurich, who collected it on a plant of *Asplenium septentrionale*. The uredo- and teleutospore-forms have both been observed. The writer gives a careful description of the fungus and adds notes on other fern rusts, which also probably belong to the genus *Melampsorella*.

Fr. Bubák§ supplies critical notes on *Puccinia fusca* and *P. Pulsatilla*. There is also information given about *P. compacta* and *P. Typhae*.

H. and P. Sydow|| publish descriptions and notes of a considerable number of species collected from many localities. Some of the American species have been determined in conjunction with Holway. Two new species of *Ustilago* are also described.

The same writers¶ give an account of the rusts found on *Anemone narcissiflora*, three different species or possibly forms of the same species, but distinguished by the size, form, and outer membrane of the spores.

**Cultures of Uredineæ.\*\***—J. C. Arthur publishes a third report of successful work on the culture of plant-rusts. He bases his work chiefly on field observation, and notes that in no case was success obtained where definite clues derived from field observations as to the hosts were lacking. He has succeeded in connecting the *Puccinia* and *Æcidium* forms of seven species, of which the teleutospores grew on grasses or sedges. The writer gives a detailed account of the different experiments.

\* Bot. Gazette, xxxv. (1903) pp. 111-33 (2 pls.).

† Journ. Mycol., viii. (1902) pp. 171-2.

‡ Ber. Deutsch. Bot. Ges., x. (1903) pp. 609-12 (1 pl.).

§ Hedwigia Beibl., xlii. (1903) pp. 28-32 (14 figs.).

|| Ann. Mycol., i. (1903) pp. 15-23.

¶ Tom. cit., pp. 33-5. \*\* Bot. Gazette, xxxv. (1903) pp. 10-23.

W. A. Kellerman\* supplies the record of sixty-seven experiments with rusts. He has been successful in many cases in tracing the life-history of various Uredineæ from host to host.

**Rusts of Leguminosæ.**†—In Europe there is but one rust belonging to the genus *Uromyces* that inhabits members of the natural order Leguminosæ. In other countries a considerable number of genera have been described. P. Dietel gives an account of these genera and discusses the relationships between them and between other closely allied genera found on other hosts. He holds that the primitive *Puccinia* had a one-celled spore, similar to *Uromyces*.

**New or Critical Species of Uromyces.**‡—Fr. Bubák has examined a number of species from Bohemia. Many of the species are new, and to all he has affixed copious critical notes. The paper is illustrated by figures of *Uromyces* spores.

**"Phthiriose," a Disease of the Vine.**§—L. Mangin and P. Viala have studied this disease, which has done much damage to the vineyards of Palestine. In that country the roots of the vine are attacked. In Europe and Africa the writers found the fungus only on the aerial organs of the plant. The disease is due primarily to the presence of a cochineal insect, *Dactylopus vitis*, which injures the root causing a flow of sap. In something like symbiotic relation with the insect, they found a fungus which lived on the sap and produced a copious mycelium round the root. The fungus does not penetrate the root, though it prevents its growth; there is a hollow space between the mycelium and the root, forming a tunnel in which insects can shelter and move about. The fungus is, they consider, one of the Uredineæ, and has been named by the writers *Bornetina corium*. From the habit and organisation of *Bornetina* they consider it to be a new type of fungus.

**Problems in the Study of Plant Rusts.**||—In an address delivered to the Botanical Society at Washington, J. C. Arthur reviews the whole position of the study of Uredineæ. He gives a historical account of the experiments undertaken to verify the doctrine of heterocœism, and the connection between the different forms. Culture-experiments have grouped in one life-cycle forms that were previously widely separated; but they have also demonstrated the limitations of certain species in regard to the hosts attacked; what was regarded as one fungus being really several distinct species.

Arthur accepts the theory that there is direct kinship between the Uredineæ and the Basidiomycetes. He discusses the nature of the spermogonium and æcidium, the first forms to be developed in the life-history of the Rusts. He considers that the telentospore closes the cycle; it is the one structure absolutely essential to the species, and persists when the other forms have disappeared.

\* Journ. Mycol., lxxv. (1903) pp. 6-13.

† Ann. Mycol., i. (1903) pp. 3-14.

‡ S.B. k. Böhm. Ges. Wiss., 1902 (1903) No. 46, 23 pp.

§ Comptes Rendus, cxxxvi. (1903) pp. 397-9.

|| Bull. Torrey Bot. Club, xxx. (1903) pp. 1-18.

In another paper \* the author takes up the question of the acidium with its accompanying spermogonium: his view is that they represent the original sexual stage and still retain much of its invigorating power.

**Merulius lacrymans.**†—Alfred Möller succeeded in making artificial cultures of the spores of dry rot and in growing the fungus to its characteristic fruiting form. He gives a full account of the methods he employed.

**Agaricus (Collybia) Henriettæ** sp. n.‡—Worthington G. Smith publishes the diagnosis of this newly discovered fungus with notes. It is intermediate between *A. radicans* and *A. longipes*. It was found in September, on and about stumps, trees, &c.

**Critical Agarics.**§—Julien Godfrin takes three nearly related Agaricaceæ, *Panæolus campanulatus*, *P. retirugis*, and *P. sphinctrinus*, and endeavours to supplement the unsatisfactory macroscopic characters by exact histological details. He finds that *P. campanulatus* and *P. sphinctrinus* are closely related, the main distinction being the thickness of the external layer of the pileus. *P. retirugis* shows a somewhat different structure in the pileus, and should therefore not be closely associated with the other two. A fourth form, *P. fimicola*, he finds so totally different in structure that he considers it ought to be classed in another genus. Anatomical study has not been carried far enough, however, to attempt a classification on such lines. The paper is illustrated by several figures in the text.

**Species of Disciseda.**||—This genus of Gasteromycetes is synonymous with *Catastoma*, but as it has priority in its favour, L. Hollös revives the name and takes occasion to review all the species that rightly belong to the genus. Nearly all of these had been previously classified under *Bovista*.

**Cauloglossum transversarium.**¶—John R. Johnston has taken advantage of fresh material of this plant to make a thorough investigation of it. It was found in the Southern States of America, and the mature specimens are club-shaped, stipitate, and olive-brown, from 3 to 7 cm. in height. Johnston describes the structure and development of the fungus, which was first described in 1811 as a *Lycoperdon*. More recently it was transferred to the genus *Cauloglossum*, but as this latter is a synonym of *Podaxon*, the writer thinks it more in order to give a new name, and so he designates the plant as *Rhopalogaster transversarium*. Its affinities are with the Hysterangiaceæ. It has the same type of columella and glebal structures, with a somewhat evanescent peridium that leaves the hymenial region exposed; the basidia and spores differ from those of the group.

\* Proc. Soc. Prom. Agr. Sci. (U.S.A.), (1902) pp. 65-9. See also Bot. Centralbl., xxiv. (1903) pp. 205-6.

† Hedwigia Beibl., xlii. (1903) pp. 6-14 (1 pl.).

‡ Journ. Bot., xli. (1903) p. 139.

§ Bull. Soc. Mycol. France, xix. (1903) pp. 44-5.

|| Hedwigia Beibl., xlii. (1903) pp. 20-1.

¶ Proc. Amer. Acad. Arts and Sci., xxxviii. (1902) pp. 61-74 (1 pl.).

**British Mycology.\***—The annual meeting and foray of fungologists took place last autumn at Hereford, and a list is given of the specimens collected, with special notes on new or rare species.

M. C. Cooke supplies a descriptive list of recent British Fungi. R. H. Biffen gives an account of the life-history of *Acrospeira mirabilis*, a mould that grows on sweet chestnuts. By means of artificial cultures the writer was able to trace the fungus through various stages up to the final fruiting form, a species of *Sphaeria*.

C. B. Plowright arranges the British Pucciniæ found on Umbelliferae according to Lindroth's recent classification. A. Lorrain Smith and Carleton Rea give an account of all the fungi new to Britain found within the past year—a long and varied list. M. C. Cooke writes on agaric transformations, and A. Lorrain Smith contributes a note on *Stilbum tomentosum*.

**Presence of a Kinase in Basidiomycetes.†**—C. Delezenne and H. Mouton, in confirmation of results of previous workers, find that extracts obtained by various means from Basidiomycetous fungi are always inactive towards fibrin and coagulated egg-albumin. They find, however, that several of these extracts when added to pancreatic juices which are quite inactive towards albumin, will give a very evident digestive power. This action is due to a soluble ferment analogous to enterokinase, but which it is of greater interest to connect with the kinases discovered by Delezenne in different bacteria and in serpent venom. A very active kinase has been found in the two slightly poisonous Agarics, *Amanita muscaria* and *A. citrina*. Only a feeble extract was obtained from the common mushroom and from *Boletus edulis*. The results suggest a relation between toxic action and the presence of a kinase.

**Mycorrhiza.‡**—P. E. Muller records the observation that *Epicea* does not flourish unless it is grown side by side with *Pinus montana*. On the roots of the latter he finds, in addition to the usual form of ectotropic mycorrhiza, a dichotomous branching and outgrowth of the lateral rootlets forming excrescences on the roots. He considers these growths comparable in function with the nodules of the Leguminosæ, and he is of opinion that they supply nitrogen to the plant and enrich the soil. There are five figures in the text illustrating the different forms of Mycorrhiza.

F. Cavers § has reviewed the literature dealing with mycorrhiza in Hepaticæ. He records many additional observations made by himself on plants he has examined. He concludes that in some of the cases where hyphæ are found the fungus may be a parasite on the host-plant. In other cases there is undoubtedly symbiotic relationship between the two organisms.

**Biological Method for Resolving Inactive Acids into their Optically Active Components.||**—A. McKenzie and A. Harden have

\* Trans. Brit. Mycol. Soc., 1902, 40 pp. (2 pls., 1 coloured).

† Comptes Rendus, cxxxvi. (1903) pp. 167-9.

‡ Overs. K. Dansk. Vidensk. Selsk., 1902, No. 6, pp. 249-56.

§ New Phytol., ii. (1903) pp. 30-5.

|| Proc. Chem. Soc., xix. (1903) pp. 48-9.

studied the action of *Penicillium glaucum*, *Sterigmatocystis nigra*, and *Aspergillus griseus* on various organic acids. Their experiments tend to show that the mode of action of the moulds is such, that the one active isomeride is attacked more readily than the other, and that the extent of the resolution depends solely on the difference of this rate of attack. The view generally held, that the one isomeride is attacked whilst the other remains untouched, does not appear to be correct.

**Fossil Fungi.\***—F. W. Oliver describes and figures two fossils from Palæozoic rocks. Small round pockets that occur on the pinnules of *Alethopteris aquilina* are filled with spore-like bodies which suggest some minute Pyrenomycete. The other case resembles a Chytridaceous sporangium and bears a close resemblance to *Grilletia Sphaerospermi*. It was found on the seed *Polylophospermum*.

Ernest S. Salmon † criticises some of the fossil Erysipheæ described by Pampaloni from the "disodile" beds. He does not agree with the conclusions of that writer. He finds on the slides submitted to him a well preserved Hyphomycete which he describes as *Cercosporites* sp.

**Jahresbericht der Pflanzenkrankheiten.‡**—The volume for 1901 has just been issued by M. Hollrung. The editor gives a sketch of each subject with a list of the papers published in connection with it. He includes harmful animals as well as harmful fungi in his discussion of diseases. There is a copious index to the volume.

**Decomposition of Lactic Acid by Fungi.§**—On solutions containing free lactic acid such as sour milk, decoction of cucumber, and sauerkraut, there appears often a surface mould composed of *Oidium lactis* or one of two species of yeast. C. Wehmer has studied the effect of the fungi on the solutions and finds that they destroy the acid and in time render the solutions alkaline.

**Proteid-Formation in Moulds.||**—Czapek studied this question in the higher plants. In moulds he finds that nitrogen is suitable in proteid formation only when it is available in the formation of amino-acids, and carbon when formed into hexose. These compounds are therefore the preliminary stage of the formation of proteids.

**Fungi in Dairy Products.¶**—Kurt Teichert found in salted butter *Oidium lactis*, *Penicillium glaucum*, and *Mucor Mucedo*. He tested their comparative growth, and found that though sugar of milk afforded small sustenance to *Oidium* and *Mucor*, it proved very nutritious for *Penicillium*. The latter mould made use of other sugars in a higher degree than the other two experimented with.

**Fat-destroying Fungi of Seeds, &c.\*\***—Wilhelm Bremer has examined the fungi that aid in the destruction and disintegration of

\* New Phytol., ii. (1903) pp. 49-53 (1 pl.).

† Journ. Bot., xli. (1903) pp. 127-30 (figs. in text).

‡ J.B. Pflanzenkrankh. (Hollrung) iv. 1901 (1903) pp. viii. and 305.

§ Ber. Deutsch. Bot. Ges., xxi. (1903) pp. 67-71.

|| Beitr. Chem. Physiol. Path., iii. (1902) pp. 47-66. See also Centralbl. Bakt., x. (1903) pp. 216-7.

¶ Milch-Zeitung, 1902, No. 51. See also Centralbl. Bakt., x. (1903) pp. 219-20.

\*\* Inaug.-Diss. Münster, Würzburg, 1902, 8vo, 75 pp. See also Centralbl. Bakt., x. (1903) pp. 156-7.



various food-stuffs. He finds that the occurrence of moulds varies according to the quantity of the moisture present. *Eurotium repens* appears first, then *Eurotium rubrum* n.sp. With a higher degree of humidity *Oidium* forms appear, and with a still higher *Penicillium glaucum*. The author notes the chemical reactions that take place, due to the growth of moulds and bacteria.

**Fungus-Flora of Piedmont.\***—Teodoro Ferraris publishes a first list of the fungi from this district, in all 162 species, many of them new to the Italian Flora, and 19 species new to science. These latter are all microscopic fungi, Pyrenomycetes or Deuteromycetes.

**Kryptogamen-Flora.†**—A. Allescher continues and concludes the addenda to the group of *Fungi imperfecti* that he has been issuing. The last two parts issued deal with the remaining species recently discovered and described, belonging to the different groups Sphaeropsidæ, Nectrioidæ, Leptostromaceæ, Excipulaceæ, and Melanconiceæ. The number of species recorded reaches the total of 5387.

**Fungi Polonici.‡**—J. Bresadola publishes a list of the fungi collected by B. Eichler. This first contribution includes the hymenomycetes, beginning with the Agaricaceæ, down to *Corticium*. Several new species are included in the list.

**Fungi from New Caledonia.§**—P. Hariot and N. Patouillard publish a list of fungi chiefly from the neighbourhood of Noumea and the Island of Pines. They have determined 84 species all belonging to the Basidiomycetes and Ascomycetes. Among the former they have determined eight species new to science, in the latter group five species are new. The authors give the habitat and locality of each plant.

**Micromycetes rariores selecti.||**—Tycho Vestergrén publishes a catalogue with diagnoses and critical remarks on 165 species included in fasc. 11–17 of his *Exsiccati*. He describes a number of new species belonging to the Hyphomycetes, Sphaeropsidæ, and Uredineæ, from Russia, Sweden, Germany, and Austria.

**Rare Sicilian Fungi.¶**—F. Cavara describes two new fungi, one of which he found on Etna last August. *Riccoa Etnensis* gen. et sp. nov.\*\* formed a stalked capitate stroma, the disc bearing minute simple sporophores with elliptical, hyaline, one-celled spores. He thinks that it may be the type of a new family intermediate between the Stilbaceæ and the Hymenomycetes. The other new species, *Ceratomyces siculus*, he collected in the botanical garden at Catania. It was characterised by a zonate disposition of the sporogenous layer, and he is inclined on that account to place the fungus rather among the Tuberculariaceæ than to consider it a form of *Polyporus*, the place usually assigned to other species of *Ceratomyces*. The writer also describes a variety of

\* Malpighia, xvi. (1902) pp. 441–81 (2 pls.).

† Rabenhorst's Krypt.-Flora, I. Abt., vii. (Leipzig, 1903) pp. 833–96 and 897–95.

‡ Ann. Mycol., i. (1903) pp. 65–96.

§ Journ. de Bot., xvii. (1903) pp. 6–15.

|| Bot. Notis., 1902, pp. 113–28 and 161–79. See also Centralbl. Bakt., x. (1903) p. 215.

¶ Bull. Soc. Bot. Ital., ix. (1902) pp. 186–90.

\*\* See also Ann. Mycol., i. (1903) pp. 41–5.

*Pleurotus ostreatus* with a black stalk, found on a dead trunk of *Ricinus communis*.

**Cryptogamic Flora of Presburg.\***—This district of Hungary has been well worked by J. A. Bäumler as regards fungi. A feature of the present contribution is the local geographical distribution of certain parasites. 479 genera and 1641 species are recorded, a few of which are new.

**Polyporaceæ of North America.†**—W. A. Murril creates a new genus *Pyropolyporus* to replace the genus *Phellinus* established by Quélet, and including *Polyporus igniarius*, *P. fulvus*, *P. conchatus*, and *P. salicinus*. Murril follows on Quélet's lines and gives a list of eighteen *Pyropolyporei*, a number of which are new. He gives detailed descriptions and critical notes on the various plants, specimens of which he has examined from different national herbaria. He finds that *P. salicinus* is but a different form of *P. conchatus*. Both are found growing together on the same hosts.

**American Mycology.‡**—Francis Bubák describes *Stannaria herjedalensis*, hitherto considered a variety of *S. Equiseti*, and *Cercospora Kellermani*, both from Ohio.

A new species,§ *Cephalosporium dendroides* E. and K., also from Ohio, is described by Kellerman, with figures of the fungus.

The sixth fascicle|| of Ohio fungi has been issued, and critical notes and descriptions of many of the species included are given by Kellerman.

Geo. F. Atkinson¶ has been examining species of *Calostoma*. He gives a series of notes on the plants and records one new to science, *C. microsporum*, from Tennessee.

Frederic E. Clements\*\* describes a considerable number of new genera and species of Pyrenomycetes and Discomycetes from various localities in the United States. The new genera are *Psilothecium*, akin to *Patinella*, but varying in the form of the paraphyses and the bright coloration; *Ophioglœa*, also one of the Patellariaceæ, with filiform septate spores; *Scytopezis*, similar to *Urnula*, but without a stalk; and *Heteroplegma* with a sessile fleshy apothecium, differing from allied genera in the form of the hypothecium.

Charles H. Peck †† describes eighteen new species, Basidiomycetes and Ascomycetes. He describes one new genus *Mitruliopsis* related to *Mitrula*, but with filiform spores.

A. P. Morgan‡‡ gives a list of 128 species of Discomycetes from the Miami Valley, Ohio. There are a number of new forms, some of which have been determined by the author, some by Masee, and others by Masee and Morgan. These are fully described. When the plant is already known the names and synonyms alone are given.

\* Beitr. Kryptogamenflora Presburg. Kom. iv. Pilze. Presburg, 1902. See also Centralbl. Bakt., x. (1903) pp. 220-1.

† Bull. Torrey Bot. Club, xxx. (1903) pp. 109-20.

‡ Journ. Mycol., lxxv. (1903) pp. 1-3.

§ Tom. cit., p. 5.

|| Tom. cit., pp. 17-24.

¶ Tom. cit., pp. 14-7.

\*\* Bull. Torrey Bot. Club, xxx. (1903) pp. 83-94.

†† Tom. cit., pp. 95-101.

‡‡ Journ. Mycol., viii. (1902) pp. 179-92.

J. B. Ellis and E. Bartholomew\* publish a short list of new microscopic forms: there is one new genus *Stachybotryella* which differs from *Stachybotrys* in its paler colour and in the absence of any perceptible basidia, the conidia arising directly from the apex of the fertile hyphæ. The specimens were collected in various localities of the United States.

**Notæ mycologicæ.**†—P. A. Saccardo contributes critical notes and diagnoses of new species. They are all microfungi and most of them collected from different districts in Italy.

**East African Fungi.**‡—P. Hennings gives a second instalment of systematic work on tropical East African fungi, with description of new forms.

**Products of Metabolism in Lichens.**§—Wilhelm Zopf has made an exhaustive study of one genus *Evernia* in regard to the formation in the plants of various vegetable acids and other compounds. His aim was to acquire a knowledge of these substances, to study the effect of locality and season on their production, and to bring the knowledge gained to bear on the determination of species by new chemical tests or otherwise. He gives an account of the methods he employed. Ether, benzole, and chloroform were the best solvents. His examination included nine species, two of which he has established as new. The products he has determined are *Atranoracid*, one of the most wide-spread lichen compounds; *Physodacid* less frequently found; *Usninacid* also very wide-spread, but present in only three of the species examined; *Divaricetacid* only in two species; *Isidacid* a new product, *Evernacid*, *Vulpinacid*, and *Olivetoracid*; the latter four products found each in one species only of *Evernia*. In some of the species he detected the carbohydrate *Evernin*. While the presence or absence of these various substances enabled him to decide sharply between different species, he found that the morphological characters in every case corresponded with his determination. Under each species he gives a detailed account of the method employed and the results obtained. In five species he found a dark-blue colouring substance on the underside of the thallus. The paper is illustrated by one figure in the text, and by photographs of the various forms assumed by *E. furfuracea*, *E. isidiophora* sp. n., and *E. olivetorina* sp. n.

**Two Marine Lichens.**||—M. Reed describes an "*Ulva*-composite" and a "*Prasiola*-composite" formed by the symbiotic union between an ascomycete of the genus *Guignardia* and *Ulva californica*, and *Prasiola borealis* sp. n. respectively. The former, *Guignardia Ulvæ*, grows at upper tide-mark on the shady side of sandstone boulders at the entrance to the Bay of San Francisco. The algal cells are distributed singly or in groups contained in capsules formed by a network of hyphæ and in a gelatinous matrix; there is a thick central zone of mycelium. The perithecia, which are found at all seasons of the year, are blackish swellings on the surface of the thallus. The ascospores are discharged in

\* Tom. cit., pp. 173-8.

† Ann. Mycol., i. (1903) pp. 24-9.

‡ Engler, Bot. Jahrb., xxxiii. (1902) pp. 34-40.

§ Beih. Bot. Centralbl., xiv. (1903) pp. 95-126 (3 pls.).

|| Univ. Calif. Pub. Bot., i. (1902) pp. 141-64 (2 pls.).

great numbers from the well-developed ostiole, and probably enter the young *Ulva* at very early stages of its development.

The *Prasiola*-composite came from Alaska; the fungal element *Guignardia alaskana* sp. n. changes the character of the alga, giving it a darker colour and in old plants a curled, crinkled, and leathery texture. The algal cells are scattered very irregularly in the mycelium. Another *Prasiola*-composite is the antarctic *Mastodia tessellata*.

B. M. Davis remarks in the *Botanical Gazette*,\* "It seems plain that these composite organs are lichens, certainly as much so as is *Ephebe*."

**Notes on Cladonias.**†—Bruce Fink and Mabel A. Husband have written careful and critical descriptions and notes on some of the well-known species of this genus in America, thus enabling beginners to gain a good understanding of their systematic position. They rely on outward form and appearance for determination. Microscopic structure, algal cells and spores are of little specific diagnostic value. The writers compare one species with another and give careful accounts of habitat, &c. The plants are illustrated by photographs.

Bruce Fink ‡ has also published an account of "Some Talus Cladonia Formations," in reference to ecologic and other conditions. He discusses the probable age of the lichen communities found growing on the tali, and also the age of the tali themselves. He records a large number of other lichens found in the same localities, and the factors that have influenced their presence. The paper is illustrated by full-page photographs of the growing plants.

**Eumycetic Fermentation.**§—This is the title of the second volume of Dr. Franz Lafar's work on Technical Mycology. The present instalment constitutes Part I. of the volume, the concluding portion of which will be translated and issued as soon as the German proofs come to hand. Part I. comprises Sections X. to XII. and Chapters XXXIX. to XLVIII. of the whole work. Section X. deals with the general morphology and physiology of the Eumycetes in four chapters. Chapter XXXIX. gives a good general account of the morphology of the group, while in Chapter XL. the composition of the cell-membrane is discussed. The next chapter deals with the mineral nutrient materials; and the occurrence and power of replacement of various elements in different fungi. In Chapter XLII. the influence of light on the development of the Eumycetes is discussed, also chemotropism and the secretion of proteolytic enzymes by members of the group.

Section XI.—fermentation by Zygomycetes—contains three chapters dealing with the morphology and systematic division of the mucors, their fermentation processes, and their use in the spirit industry. Section XII. entitled, Form, structure, and chemical composition of

\* *Bot. Gazette*, xxxv. (1903) pp. 229-30.

† *Bryologist*, vi. (1903) pp. 21-7.

‡ *Bot. Gazette*, xxxv. (1903) pp. 195-208 (5 figs.).

§ 'Technical Mycology: the Utilisation of Micro-organisms in the Arts and Manufactures. A Practical Handbook on Fermentation and Fermentative Processes for the use of those interested in the Industries dependent on Fermentation.' By Franz Lafar, translated by Charles Salter. Griffin, London, 1903, viii. and 189 pp., with 68 figs. in text.

the yeast-cell, also comprises three chapters in which the morphology and life-history of the yeasts and the anatomy and the chemistry of the yeast-cell are dealt with in turn.

The general student will find much that is useful in the book, which is well illustrated with figures from works of Brefeld, Zopf, Hansen, and other mycologists.

#### Schizomycetes.

**Thermophilous Bacteria.\***—Mlle. Tsiklinsky has investigated a number of bacteria which have an optimum temperature about 55° C. and a maximum between 60° and 70° C. These bacteria, as earlier observations have well shown, are very widely distributed in nature, e.g. in the soil, both at the surface and at a considerable depth, in rivers, in dust, in milk, in the excrement of animals, in the mouth and throughout the digestive canal of man, and even in freshly fallen snow. The author has investigated five thermophilous bacteria from the hot water of the thermal springs of the island of Ischia, but most of her observations were made on the thermophilous bacteria found in meconium, in the fæces of infants only a few days old, and in the fæces of adults. From these three sources about twenty bacteria are described, to most of which no names are given. A form called *Thermostreptothrix vulgaris* was isolated from soil, and from the same source a thermophilous conidia-bearing fungus was isolated, to which the name of *Thermomyces lanuginosus* was given. This curious fungus grows best between 42° and 60° C., and is capable of only slight development at 37° C., and of still less at the ordinary temperature. The paper ends with a discussion of the value or otherwise of the bacteria found in the alimentary canal of man and animals.

**Accumulation Experiments with Denitrifying Bacteria.†**—G. van Iterson, jr., describes the results of a series of experiments in which access of air was partly or completely prevented. He has succeeded, by cultivating in solutions of organic salts and nitrate, in bringing many denitrifying bacteria to a more or less perfectly pure culture. Of these experiments three always gave constant results, producing respectively *Bacterium Stutzeri* Neum. and Lehm., *B. denitrofluorescens* sp. n., and *B. vulpinus* sp. n. The first named deserves attention on account of the unique structure of its colonies (as figured). The second species is the first example of a denitrifying non-liquefying fluorescent bacterium. *B. vulpinus* is a brown-red pigment-bearing species; the pigment forms only in the light. *B. Stutzeri* and *B. vulpinus* behave towards free oxygen like aerobic spirilla, the third species like an ordinary aerobic bacterium.

The author finds that denitrifying bacteria are generally distributed in canal and sewage water. They can, even with the slightest quantity of various organic substances, cause the disappearance of determined quantities of nitrate with development of free nitrogen. In one and the same culture medium where nitrification is produced during aëration,

\* Bull. Soc. Imp. Nat. Moscou, 1902, pp. 380-467 (10 tables and 2 pls.).

† Proc. K. Akad. Wetensch. Amsterdam, v. (1902) pp. 148-62 (1 pl.).

denitrification may be caused by exclusion of air, and the same holds good in regard to the soil.

**Nitrogen-fixing Bacteria.\***—Gerlach and Vogel have made fresh observations on the relation between a supply of organic material (grape-sugar, calcium propionate, &c.) and the fixing of free nitrogen by soil bacteria. The bacterium used was *Azotobacter chroococcum*, and it was found that an increase of grape-sugar up to 12 grm. per 1000 led to an increase of nitrogen fixation, but above that amount an increase in sugar led to a decrease in the activity of fixation. Their further work is a consideration of the results obtained by Beijerinck and van Delden in their work on nitrogen-fixing bacteria.

**Culture of the Nitroso-Bacterium.†**—H. S. Fremlin finds that a practically pure culture of the nitroso-bacterium can be obtained after sub-culturing for seven months in Winogradsky's ammonia solution, which consists of water containing 1 per 1000 ammonium sulphate, 1 per 1000 potassium phosphate, and 1 per 100 magnesium carbonate. The bacterium will grow in this solution in the presence of organic matters such as are contained in peptone beef broth, Witte's powdered peptone, and urea. The author also shows that the bacterium will grow not only on silica jelly but also in any ordinary organic medium.

**Motility of Rhizobium.‡**—Albert Schneider continuing his investigations of the leguminous tubercle bacteria, states that he has now discovered that when the Rhizobia of sweet clover are transferred to acid media they become much smaller and more uniform in size, and move with a rapid, jerky, to and fro, and rotary movement. To the bacterium from this clover he gives the name of *R. mutabile*, a species which he believes will prove to be the chief or dominant type as it occurs in the tubercles of the greater number of leguminous plants. In neutral media the organism remains non-motile.

**Observations on Sarcina, Streptococcus, and Spirillum.§**—David Ellis has made a long and very complete series of comparative morphological and physiological observations on *Sarcina ureae* Beijerinck, *Streptococcus tyrogenus* Henrici, and *Spirillum giganteum* Migula.

**New Group of Sulphur-Bacteria.||**—A. Nathansohn describes a new group of sulphur-bacteria observed by him in sea-water to which potassium sulphide had been added, and which had been infected with Beggiatoa-like organisms. They were afterwards cultivated and studied in sea-water with the addition of 0.1–1 p.c. sodium thiosulphate or some similar medium; no organic food was necessary. A large number of forms of this group were isolated by means of plate cultures, but in this paper their metabolism only is described. The organisms were unable to develop in the absence of CO<sub>2</sub>, but they were unable to oxidise such substances as glucose, though these organic substances had no ill-effect on their growth. It would seem that in these curious

\* Centralbl. Bakt., ix. (1902) pp. 817–21 and 881–92.

† Proc. Roy. Soc., lxxi. (1903) pp. 356–61.

‡ Bot. Gazette, xxxv. (1903) pp. 56–8.

§ Centralbl. Bakt., xxxiii. (1903) pp. 1–23, 81–96, 161–66 (2 pls.).

|| Mittheil. Zool. Stat. Neapel, xv. (1902) pp. 655–80.

bacteria a thiosulphate takes the place of the carbon compound usually concerned in the respiration of other plants.

**Staining of Streptotrichaceæ.\***—E. Fuchs states as the result of his investigations, that staining by methods hitherto supposed to be specific for tubercle-bacillus and allied species, is a general character of the Streptotrichaceæ. These results confirm Zupnik's view as to the close relationship between these two groups of bacteria.

**Resisting Powers of Staphylococcus pyogenes aureus.†**—F. W. Andrewes describes observations illustrating the remarkable resisting powers of this organism to mercuric salts. A strain of this coccus in broth cultures resisted 1 in 500 perchloride of mercury for 45 minutes, and in pure water for 12½ minutes. By repeated passages through the perchloride a strain was produced with increased powers of resistance, withstanding 1 in 500 of the perchloride in pure water for 20 minutes. The resistance to biniodide of mercury was as great, but it did not extend to antiseptics of other groups.

**Immunising Effects of Contents of Typhoid Bacillus.‡**—Allan Macfadyen finds from experiments on the monkey that by the injection of the intracellular juices of the typhoid organism it is possible to obtain a serum with both antibacterial and antitoxic properties; and that such a serum possesses curative and preventive properties as regards the typhoid bacillus, and an intracellular toxin present in the same organism. The author believes that the results of this research afford for the first time proof that, in the case of one species of pathogenic bacterium, the intracellular juices of the organism, when injected into a suitable animal, give rise to the production of a serum which is both bactericidal to the organism itself, and antitoxic as regards a toxin contained in its substance. How far such properties of the cell-juice are shared by other pathogenic microbes must be the subject of further inquiry.

\* Centralbl. Bakt., xxxiii. (1903) pp. 649-53.

† Brit. Med. Journ., 1903, i. p. 198.

‡ Proc. Roy. Soc., lxxi. (1903) pp. 351-2.



## MICROSCOPY.

## A. Instruments, Accessories, &amp;c.\*

## (1) Stands.

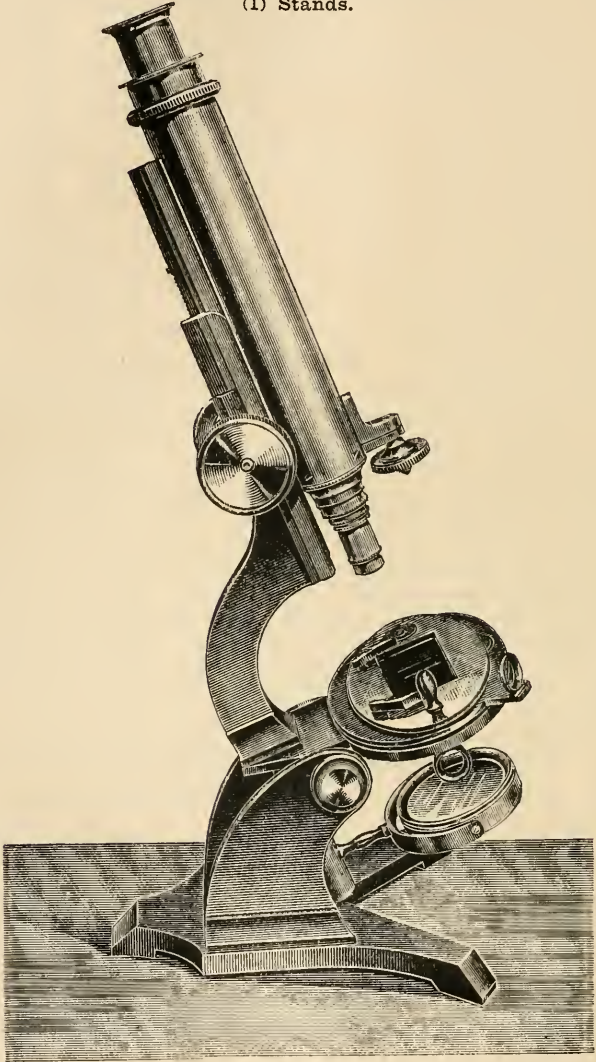

FIG. 121.

Old Microscope by M. Pillischer.—Figs. 121 and 122 represent the Microscope made by Michael Pillischer about 1847 for Sir William

\* This subdivision contains (1) Stands; (2) Eye-pieces and Objectives; (3) Illuminating and other Apparatus; (4) Photomicrography; (5) Microscopical Optics and Manipulation; (6) Miscellaneous.



White-Cooper. This instrument was exhibited by Mr. Jacob Pillischer at the March meeting (see p. 245). Fig. 121 gives a general view of the instrument, and fig. 122 shows the Tomes stage opened out and the method of pivoting the three oval plates. When used as a dissecting Microscope, these plates form convenient tables on which to place specimens and small instruments.

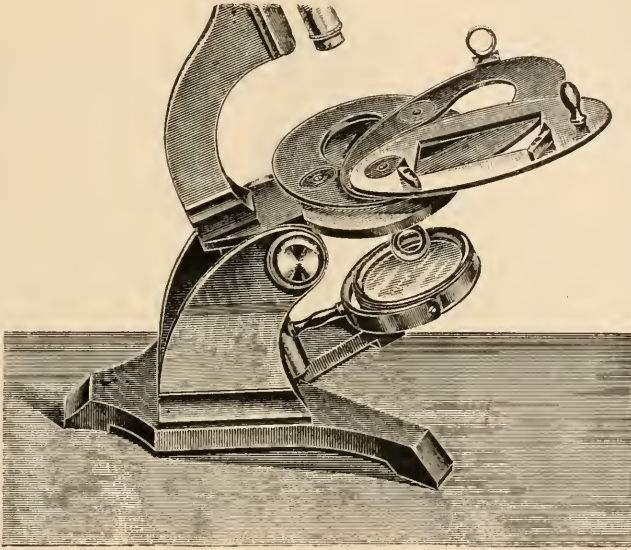

FIG. 122.

**New Portable Microscope.**—This Microscope, figs. 123 and 124, exhibited at the June Meeting by Dr. C. Charlton Briscoe, was made from the design of Prof. Herbert Jackson by Messrs. Swift and Son, who suggested several of the details in its construction. It is specially designed for use at the bedside, and, considering the work it is capable of doing, is of unusually small dimensions.

The body, which can be extended by a draw-tube to 160 mm., slides in a cloth-lined fitting; it has an eye-piece of R.M.S. standard gauge, and the nose-piece takes objectives with the standard screw-thread. The fine adjustment is steady with the highest powers.

The stage, which is one of the chief novelties in this instrument, has  $\frac{3}{4}$ -in. motion vertically and transversely, the latter motion being in arc.\* The substage condenser is achromatic and has an aplanatic aperture of 0.92; the top lens can be removed when using low powers. It is fitted with iris diaphragm and throw-out cell and screws for centring.

\* The transverse movement of the stage in arc is not new. A figure of a Microscope, made about 1855-60, having a stage with this movement, is given in the Journ. R.M.S. for 1898, p. 668.

The case, made to hold the instrument with bottles of solutions, blood-counting slide, pipettes, and other items, measures 8 in. by 4 in. by  $1\frac{3}{4}$  in., and weighs under 2 lb., but the Microscope can be fitted by itself in a case measuring  $6\frac{1}{2}$  in. by  $3\frac{1}{2}$  in. by  $1\frac{3}{10}$  in., and the weight with two objectives would then be under  $1\frac{1}{2}$  lb.

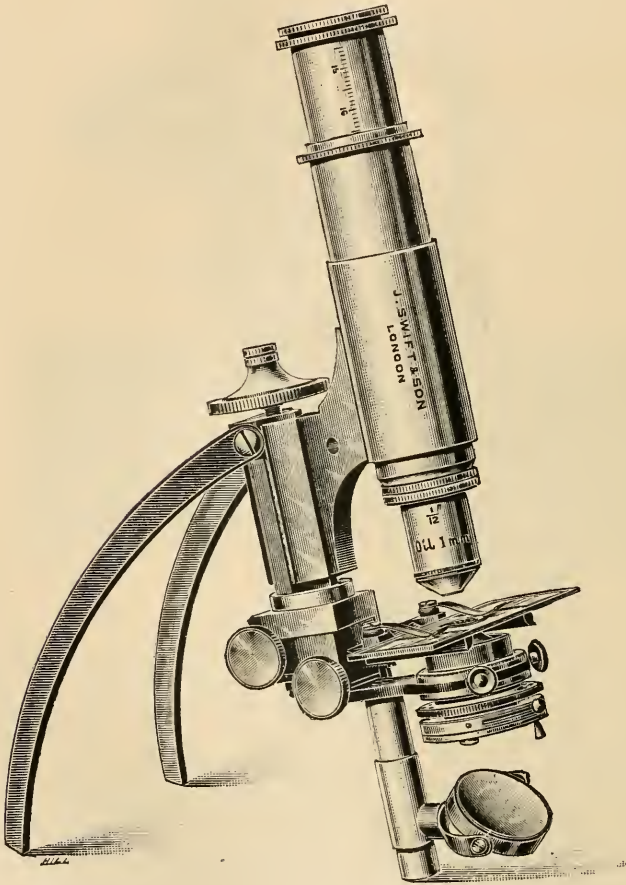

FIG. 123.

**Beck's Portable Continental Model.\***—This Microscope, known as Stand No. 1123, is shown in figs. 125 and 126. It has a sliding coarse adjustment, and a delicate micrometer-screw fine adjustment. The stage,

\* Messrs. R. and J. Beck's Catalogue, London, p. 18.

with its revolving diaphragm, swings round for facility in packing, and the base is made folding for the same purpose. It is packed in a morocco-covered case, measuring 8 by  $2\frac{3}{4}$  by  $2\frac{1}{2}$  in.

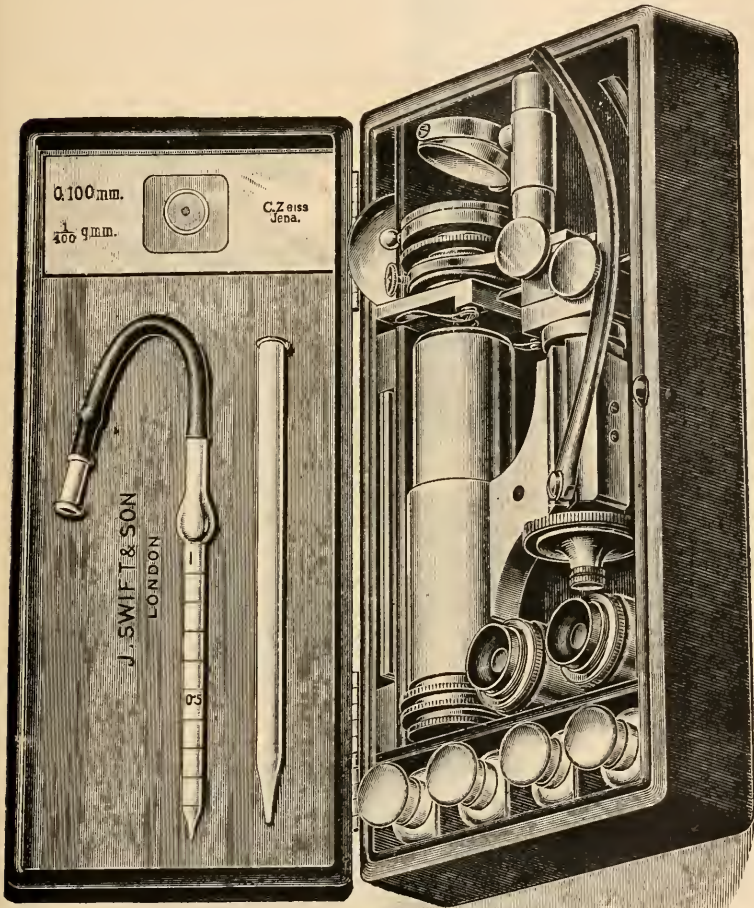

FIG. 124.

**New Double-hinged Limb-holder.\*** — Messrs. Leitz have made for M. P. Porsild a double-hinged limb, so that their preparation Microscope may be used for several other purposes. The upper part of the limb (fig. 127) is of the usual character, but is raised and lowered by rack-and-pinion operated by the milled heads shown below the stage. Near

\* Zeitschr. f. wiss. Mikr., xix. (1902) pp. 41-4 (2 figs.).

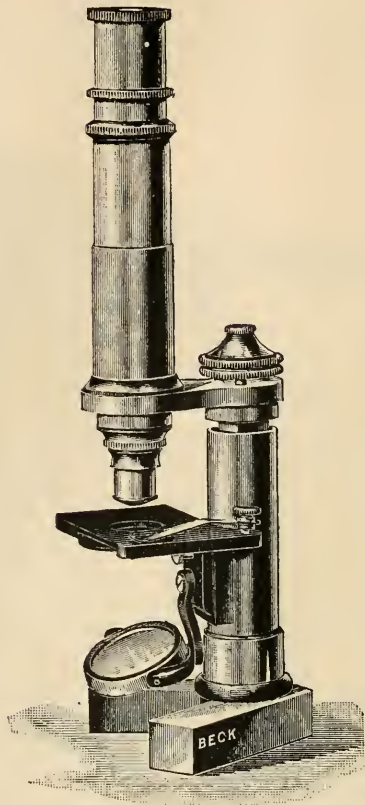

FIG. 125.

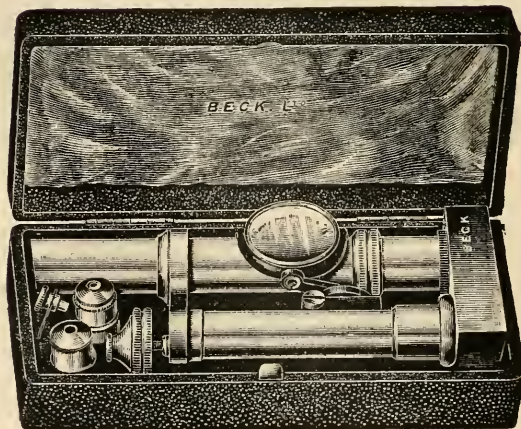

FIG. 126.

the lower end of the limb is a hinge, which permits it to be vertically rotated through  $90^\circ$ , so that the tube-axis can be brought parallel to the stage. In this position the instrument can be used as a cathetometer, or Microscope for reading vertical distances, especially for such subjects as plant-growths which could be estimated by the eye-piece micrometer

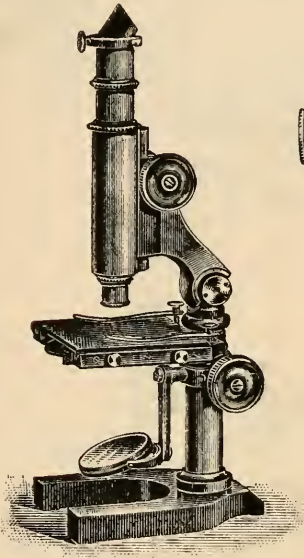

FIG. 127.

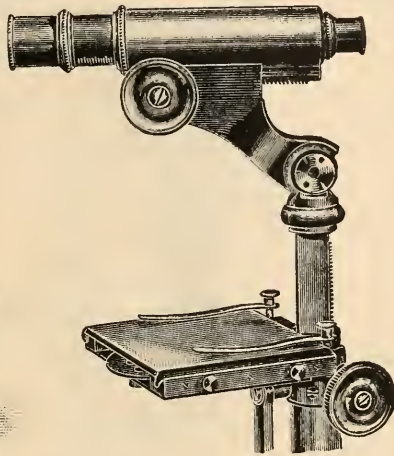

FIG. 128.

measurements. A millimeter scale could be engraved on the triangular bar. Below the stage the pillar has a rotation hinge which enables the optical part to be used with greater freedom (fig. 128).

The instrument can also be conveniently used as an aquarium Microscope, but it would be an improvement to lengthen the lower end of the tube.

Even when the instrument is used as a preparation Microscope the double hinging is useful, as it facilitates search over the field.

**Koristka's Mechanical Stage.\***—This accessory is shown in fig. 129. The movements in the two directions are 80 mm. and 40 mm. respectively, and the two divided scales are provided with verniers, which

\* F. Koristka's Catalogue, Milan, p. 54.

serve to fix the position of any point of interest. Both screw-heads are placed on the left so as to leave the operator's right entirely free.

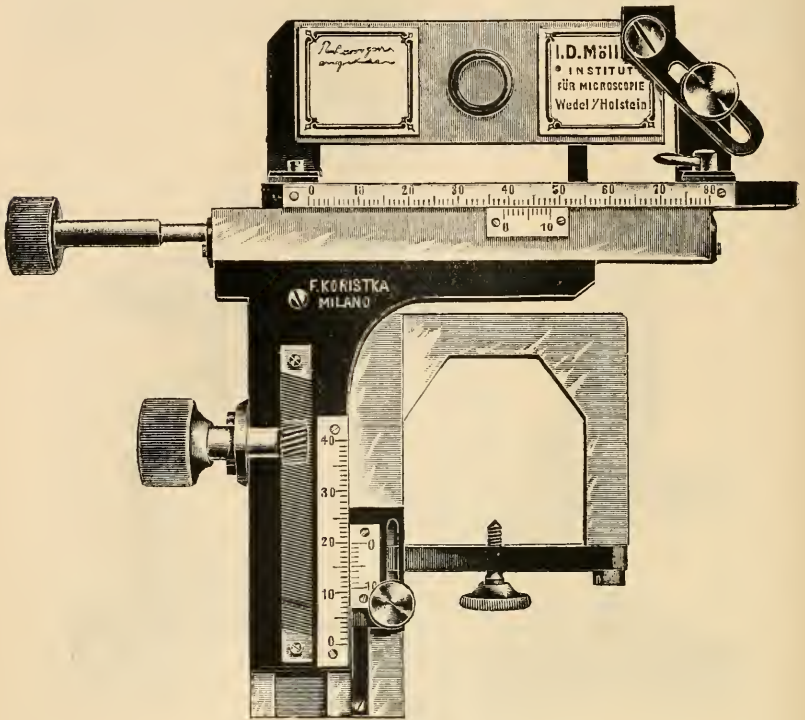

FIG. 129.

**Koristka's Hand Magnifiers.\***—The loup shown in fig. 130 has two pairs of two achromatic cemented lenses. The mount of the upper works in a thread so that its distance from the lower pair can be altered. In this way the magnifying power can be varied from 5 to 10 diameters. The field in each case is flat and large.

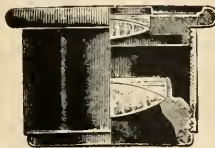

FIG. 130.

\* F. Koristka's Catalogue, Milan, fig. 50, p. 64.

## (3) Illuminating and other Apparatus.

**New Projection Apparatus for Scientific Work.\***—L. B. Elliott, in designing this instrument, has adopted the fundamental principle of a fixed optical centre for all parts of the apparatus, the only adjustment required being that to bring the source of light into the optical axis and to separate it the proper distance from the first element, namely, the rear lens of the condensing system. To this end all the optical parts and their connections are mounted upon vertical pillars attached to heavy steel blocks, which, in turn, are mounted upon a steel bar, rectangular in section, having two inclined surfaces, accurately planed, on

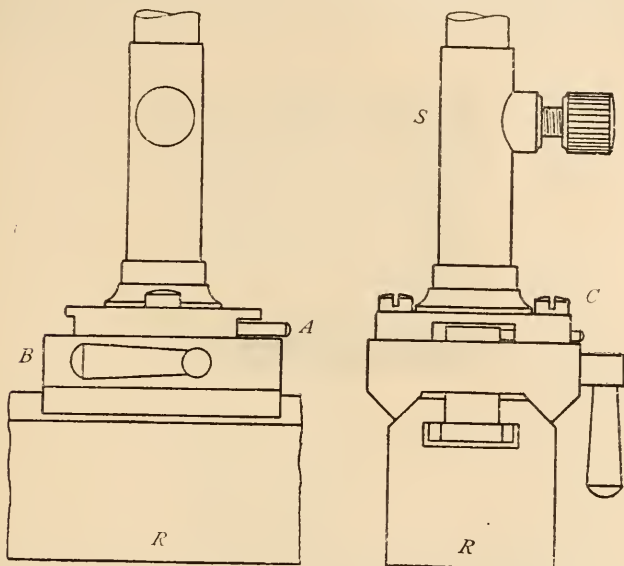

FIG. 131.

its upper side, the whole contrivance resembling a fine lathe-bed in rigidity and accuracy of centring. A T-slot is milled in the upper portion of the rod from one end to the other, and in this a T-piece attached to a vertical axis passing through the block and carrying the optical parts is placed. The T-piece may be rotated through  $90^\circ$  by means of the lever A, fig. 131, placing its long axis parallel with the axis of the T-slot, when the whole block may be lifted off from the bar, or if removed may be replaced upon the bar and held in position by releasing the lever A, which is actuated by a spring, causing the long axis of the T-piece to assume a position at right angles to the axis of the T-slot. This lever, being actuated by a spring, automatically locks

\* Journ. App. Micr., vi. (1903) pp. 2136-47 (8 figs.).

the block on the rod, preventing accidental overturning during adjustment. The block with whatever optical apparatus it may carry, now rests upon the two inclined surfaces of the bar, and may be slid along its length, permitting whatever adjustment is required, and when in proper position the lever B is depressed, locking the whole rigidly upon the bar by means of a cam which draws the T-piece firmly against the top of the T-slot. It will thus be seen that any part of the optical equipment can be removed from the apparatus, or replaced, by releasing the T-piece through the operation of the lever B, and rotating the lever A through  $90^\circ$ , and that each element will always return exactly in the optical axis, since its support rests only on the two inclined surfaces of the rod R, and must in every case find the true centre through the clamping action of the cam lever B. The rigidity of the steel bar R and the heavy construction of the base-blocks and vertical supports of the optical part

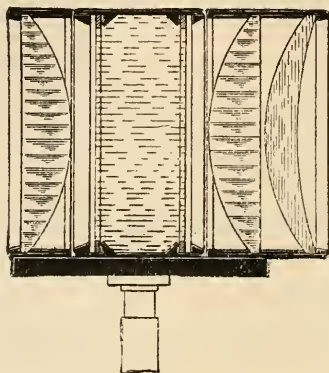

FIG. 132.

retain the alignment and centring. Fig. 131 shows the details of construction of the base-blocks for apparatus supports with the two inclined planes on which the blocks rest. S is the piece in T-slot which, when rotated  $90^\circ$  by the lever A, permits the removal of the base-block from the rod; B is the clamping lever, which clamps the base-block rigidly on the rod R. Fig. 132 is a section of the condenser and water-cell. The condenser is a triple system between the two anterior elements of which the water-cell is placed, securing the maximum absorption of heat rays with the minimum loss of light. The hand-fed electric arc lamp is shown in Fig. 133 and is formed of a vertical and a horizontal carbon, which are therefore at right angles to one another. They can be actuated simultaneously or separately. The placing of the carbons at an angle of  $90^\circ$  to one another with the horizontal carbon in the optical axis not only throws a greater volume of light from the crater of the positive carbon through the condensing lenses, but retains the glowing crater always exactly in the optical axis, no matter how irregularly the two carbons may burn. Fig. 134 shows the whole apparatus complete.



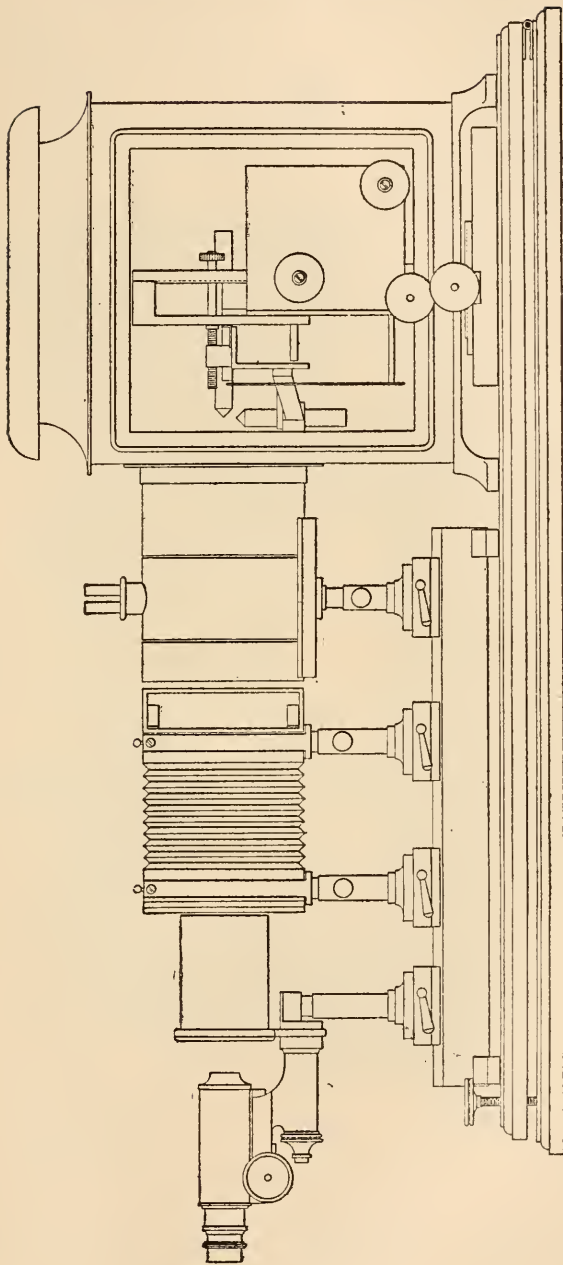

FIG. 133.

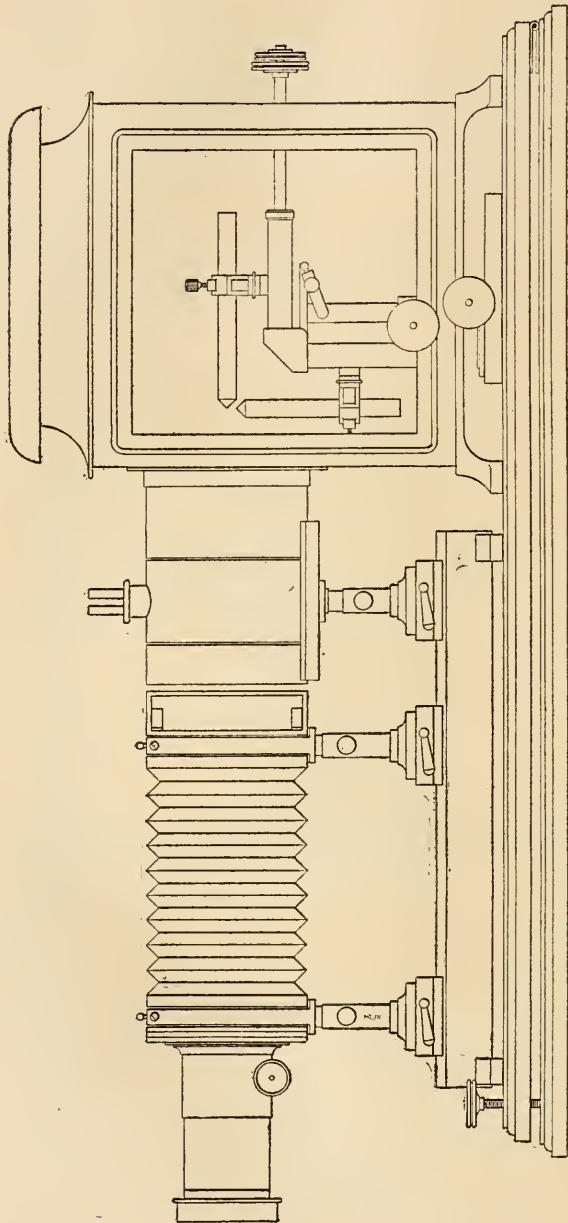

Fig. 134.

Koristka's Apparatus for the Microscopic Projection of Liquid Preparations.\*—This arrangement is shown in fig. 135. The electric

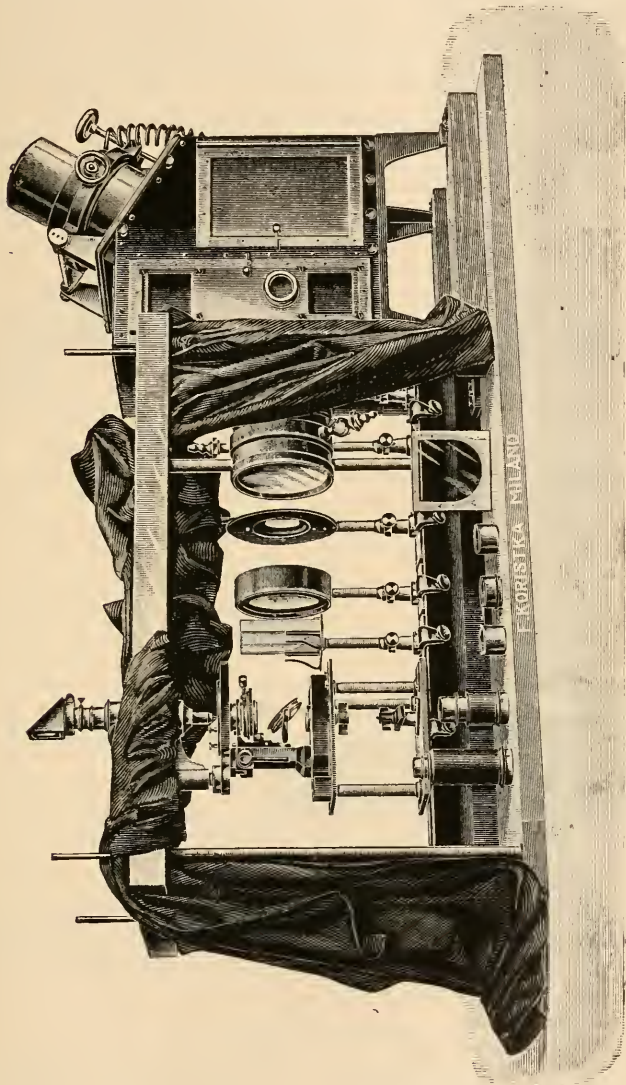

FIG. 135.

rays, after proceeding through the usual diaphragms and condensers, impinge upon the mirror of the Microscope. They are then reflected up

\* F. Koristka's Catalogue, Milan, fig. 70, p. 81.

through the tube and are again reflected at the hypotenuse of an isosceles right-angled prism. The emergent rays can then be received on any convenient screen.

**Koristka's Abbe Camera Lucida with Lens-Holder.\***—This instrument, shown in fig. 136, while principally designed for low powers, is also adapted for drawing objects their natural size without the aid of a lens. The camera lucida with its large mirror, 90 by 150 mm., and with

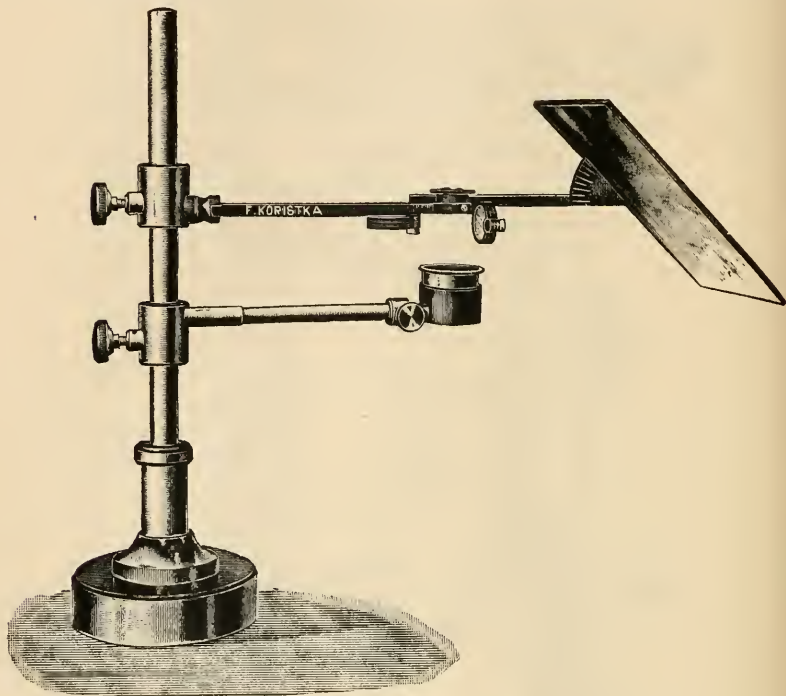

FIG. 136.

gilded double prism, takes a very large field. It is fitted with two series of smoked glasses, one for interposing between the prism and the mirror and the other for insertion between the prism and the magnifying lens.

(6) Miscellaneous.

**Jena Glass.†**—The nature of the contents of this book place it out of the reach of ordinary criticism. It can scarcely be compared, it

\* F. Koristka's Catalogue No. 11, Milan, 1903, fig. 45, p. 63.

† 'Jena Glass and its Scientific and Industrial Applications,' by Dr. H. Hovestadt. Translated and edited by J. D. Everett, M.A., F.R.S., and Alice Everett, M.A. Macmillan & Co., London, 1903, 8vo, xiv. and 419 pp., 29 figs.

stands almost alone. It is a scientific discourse upon an entirely new series of optical metals. It would be well if we had accessible anywhere an equally accurate and efficient account of optical glasses in use before this remarkable and most valuable series of Jena glasses were devised and made accessible.

As a treatise it is a monument to the scientific knowledge, skill, ingenuity, and indomitable resolution of German men of science. The labour must have been great; the book is practically a record of various experiments which have been made to discover the composition needful to obtain a series of optical fluxes which should possess the properties optical and mechanical for securing results that had been before optically impossible. Sir I. Newton had satisfied himself that the hindrance to the production of a perfect optical instrument, such as a telescope, was not the production of perfect figures in the glasses, but the different refrangibility of the rays of light. In the glasses used in the construction of optical instruments prior to the production of the optical fluxes of Jena, two kinds of glass having proportional dispersion powers could not be found; as is well known, "irrationality of spectrum" resulted and absolute chromatic correction could not be accomplished. The want of proportion in the dispersion of the various colours of the spectrum in two kinds of glass, such as were obtainable before the Jena glasses were produced, left a colour or colours outstanding in "corrected" or achromatic combinations of, for example, microscopic object-glasses, known as the *secondary spectrum*.

It is by the production of the most ingenious vitreous compounds of which this book gives careful history and elaborate scientific details, combined with fluor-spar, that this secondary spectrum was removed and a new era for microscopic objectives and work inaugurated; and in every field in which optical instruments are used an immensely important series of improvements have resulted.

Amici showed that the introduction of a drop of water between the first surface of the object-glass and the covering glass of the object would diminish the loss of light which arose from the passage of the rays from the object into air before reaching the objective. Sir David Brewster had seen and suggested this as far back as 1813, and its adoption was known as the "water-immersion." Clearly, however, when the rays enter the object-glass from water instead of air, both its refractive and dispersive action will be altered; and important constructive modification would be needed to suit the new conditions. Hartnack was the first to successfully bring this about, and the immersion system was introduced. This system was still more powerfully to influence the future of the Microscope, under the now famous *homogeneous system of immersion*. This system was first suggestively employed by Tolles; but Prof. Abbe had at the same time a more or less clear perception of its potential value. "The matter assumed, however, subsequently, a different shape in consequence of a suggestion made by Mr. John Ware Stephenson . . . of London, who independently discovered the principle of homogeneous immersion." \*

\* Abbe, this Journal, ii. (1879) p. 257.

The new method consisted in the replacement of the water in the immersion system by cedar oil which is placed between the front surface of the object-glass and the upper surface of the cover-glass of the mounted object. The oil has the same refractive and dispersive power as crown glass, and therefore the correction collar, though a refinement having value still, was no longer inevitable.

The construction of a combination of lenses which would satisfy these conditions was earnestly desired and ultimately urged by Mr. Stephenson upon Prof. Abbe; and eventually the long series of researches and experiments so efficiently detailed in the book we are considering led to the formation of new vitreous compounds making possible the large numerical apertures and almost perfect corrections of an entirely new series of lens-combinations now known as "apochromatic"—opening a new era in Microscopy.

This glass is now so generally used in all high class optical work throughout the world, that a book like this giving authoritatively much that it is of the greatest value to know concerning its construction and its optical and mechanical properties, is a boon to all working opticians, and a service rendered to mathematicians and physicists.

Many pages are given to the consideration of the optical properties of the glasses, and to the manner in which the perfection of optical systems is secured by the utilisation of the special properties of the glasses. Almost equally interesting is the discussion of the mechanical properties of these vitreous combinations, which are carefully recorded and explained.

Much space is devoted to quite another feature which these glasses in a marked degree are distinguished by, which is their endurance and behaviour under varying thermal conditions. One important matter especially to the employment of these compounds for optical lenses and especially for the lenses of Microscopes, is the manner in which lenticular surfaces made of the compounds are susceptible to tarnish and inimical changes when exposed to varying conditions of atmosphere.

From this book it is manifest what great advances can be made by steady purpose in investigation and enterprising experiment. The advancement of practical optics by the devising of these vitreous compounds has been very great, and as a side-issue it is not unimportant that the discovery of the combinations has shifted the centre of the world's optical work from England to Germany. The annual inflow into England alone of optical instruments from Germany represents, relatively, a new item and one of immense financial importance. But it is not to be supposed that all that can be done has been done. May we not hope that the enterprise of English opticians will lead them to make effort, so that what is still attainable in the yet further advancement of the "metals" out of which lenses may be rendered still more efficient, shall if possible be secured?

**B. Technique.\*****(1) Collecting Objects, including Culture Processes.**

**Apparatus for Decanting off Culture Fluids.**†—W. Behrens describes an apparatus constructed by V. Basila which is intended for removing from a stock vessel definite quantities of culture media without fear of contamination.

The apparatus, made entirely of glass, consists of an Erlenmeyer's flask *A* in connection with which is a spherical vessel *D*, the latter having a suction-tube *C* and a discharge pipe *B*. By means of the taps *E* and *F*, *D* can be shut off above and below. By means of the tap *E* the communication between *D* and *A* and *B* can not only be cut off but can be made with one or both simultaneously. The tap *F* is so bored that it allows air to pass either way.

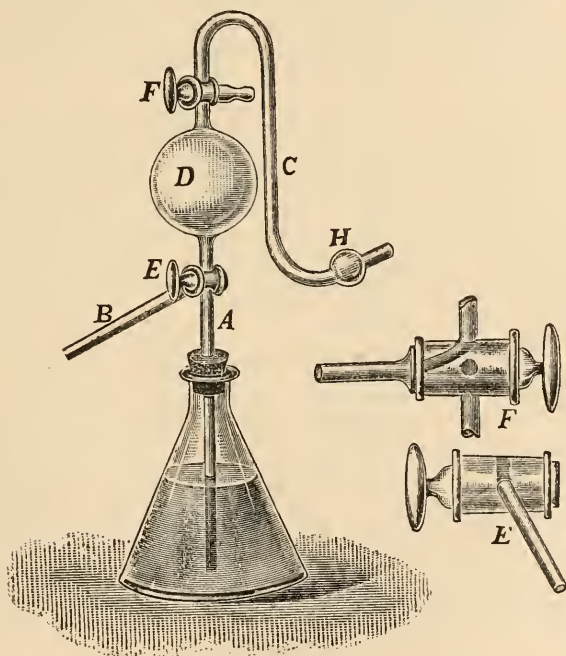

FIG. 137.

When the apparatus is to be used, cotton-wool is stuffed into the bulb *H*, the flask is filled with culture fluid, and the whole having been steam sterilised the caoutchouc plug is inserted. The tap *E* is turned

\* This subdivision contains (1) Collecting Objects, including Culture Processes; (2) Preparing Objects; (3) Cutting, including Imbedding and Microtomes; (4) Staining and Injecting; (5) Mounting, including slides, preservative fluids, &c.; (6) Miscellaneous. † *Zeitschr. wiss. Mikr.*, xix. (1903) pp. 429-31 (1 fig.).

so as to close A and B. The tap F is now opened so that the interior of D is in communication with the external air, and then by means of a suction pump a vacuum is made in D. By closing F and opening E, some of the culture fluid ascends into D, and then by another turn given to E, any desired quantity can be run off through the tube B.

### (2) Preparing Objects.

**Decalcification Method.\***—As the outcome of an elaborate series of experiments with various reagents under different conditions, J. Schaffer thus formulates his method of decalcification. The piece of tissue must be well fixed and then carefully imbedded in celloidin. Harden the celloidin block in 85 p.c. alcohol, after which remove the alcohol by immersion in water. Then place the block for 12 to 24 hours, or still longer if the piece be large, in 3 to 5 p.c. nitric acid, using a Thoma's water-wheel. From the acid the block is transferred to a 5 p.c. solution of lithium and sodium sulphate. In this it should remain from 12 to 24 hours, the solution being changed at least once. Then wash in running water for 48 hours, after which dehydrate in graded alcohols up to 85 p.c.

**Reagent Bottle.†**—S. E. Dowdy describes a drop-bottle for containing and applying stains and reagents used in histological work. The apparatus consists of a wide-mouthed bottle, a tight-fitting cork, a couple of pieces of glass tubing, a rubber teat, and a piece of rubber tubing to connect up the outlet tube. Its advantages consist in keeping the reagent free from dust, in allowing its removal without taking out a stopper, and in the control over the amount deposited on the slide. Empty bottles may be used for removing excess of liquid from slides and also as a gathering pipette and collecting bottle for pond life.

### (3) Cutting, including Imbedding and Microtomes.

**New Imbedding Medium.‡**—G. Marpmann recommends celluloid dissolved in acetone as an effective substitute for celloidin. Celluloid chips, which are very cheap, are placed in a wide necked bottle and covered with about ten times their bulk of acetone. The bottle, which should be tightly corked, must be frequently shaken at intervals and then allowed to stand until the celluloid is quite dissolved. The clear supernatant fluid is then poured off. Two solutions are required, one thin, the other of a thick syrupy consistence. The material, which must be perfectly dehydrated, is placed in the thin solution for some days and then some of the thick solution is poured in. The medium is inspissated by allowing slow evaporation under a bell-jar.

The blocks, which should be free from cracks or holes, may be kept in 80 p.c. alcohol. The sections may be mounted as they are, or the celluloid may be dissolved out by means of acetone.

**New Freezing Plate for Hand Microtome.§**—B. Solger describes a microtome with a new freezing plate which is to all intents and pur-

\* Zeitschr. wiss. Mikr., xix. (1903) pp. 308-28, 441-63.

† Eng. Mech., lxxvii. (1903) p. 169.

‡ Zeitschr. angew. Mikr., ix. (1903) pp. 14-6.

§ Zeitschr. wiss. Mikr., xix. (1903) pp. 294-6.



poses a modification of the Roy model. It consists of a foot-plate about 3 cm. long, attached to a screw clamp which serves to fix the instrument to the bench and supporting a slot for the reception of the nozzle of the ordinary spray apparatus attached to its upper surface. The foot-plate supports the freezing-plate (5 cm. by 2 to 2.5 cm.) by means of a short upright (about 2 cm.) The under surface of the

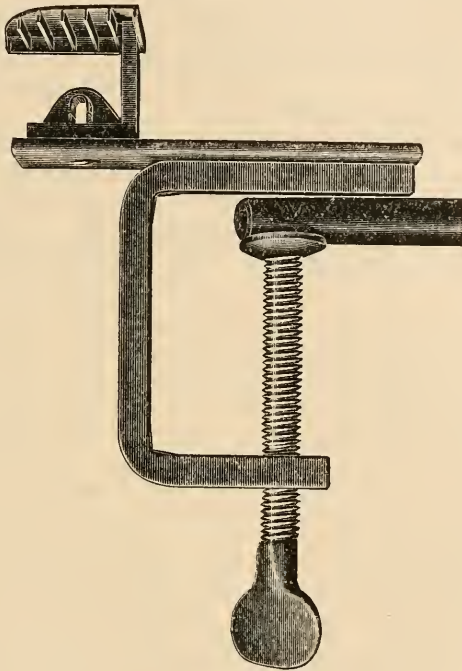

FIG. 138.

freezing-plate is traversed by several metallic ridges. The microtome, which is made by Leitz, is constructed entirely of steel and iron, and is nickeled.

#### (4) Staining and Injecting.

**Staining Nervous Tissue with Gallein.\***—H. Schrötter finds that gallein, a pigment belonging to the eosin group, stains the medullary sheath of nerves very well. The dye is dissolved in boiling water.

Sections of spinal cord are immersed in the solution for 15 to 20 minutes, and then differentiated in a 5 p.c. solution of soda. After washing in water and dehydrating in absolute alcohol they are treated with carbol-xylo. The medullary sheaths and medullated fibres are

\* Centralbl. allgem. Pathol. u. pathol. Anat., xiii. (1902) pp. 299-300.

stained violet. By washing in dilute permanganate of potash after the soda bath a still sharper picture is obtained.

The best fixative appears to be Müller's fluid.

H. Aronson\* remarks that he published the foregoing method in 1890, but his communication attracted little attention, though it contained the important observation that basic pigments attach themselves very firmly to fibres which have been stained red with gallein.

**Modification of the Method for Staining with the Ehrlich Triacid Solution.**†—Morel and Doléris mix equal volumes of the triacid solution and 8 p.c. formalin and then add 1 per thousand acetic acid. The effect of this solution is to fix the methyl-green in the nuclei. The material is best hardened in Zenker's fluid.

The sections should be immersed in the stain for 10–20 minutes.

HEIDENHAIN, M.—Ueber chemische Anfärbungen mikroskopischer Schnitte und fester Eiweisskörper. (On the chemical stainings of microscopic sections and of solid albuminous bodies.) *Zeitschr. wiss. Mikr.*, XIX. (1903) pp. 431–41.

„ „ Ueber chemische Umsetzungen zwischen Eiweisskörpern und Anilinfarben. (On chemical changes between albuminous bodies and anilin dyes.) *Arch. ges. Physiol.*, XC. (1902) p. 115.

(5) Mounting, including Slides, Preservative Fluids, &c.

**Staining and Mounting Urinary Sediment.**‡—B. Kozlowski states that he has got mounts of urinary sediment (cells, casts) which have kept unchanged for quite five years. About 1 c.cm. of a weak solution of some aniline dye is added to the urine. A 1 p.c. solution of eosin acts very well. The urine is then centrifuged and the process repeated with the sediment. The last drop of urine is removed. A drop of the thick sediment is then deposited in a drop of Farrant's medium previously placed on a slide. The two are mixed together and then a cover-glass put on. The preparation should be ringed round with a liquid cement made by dissolving caoutchouc in bisulphide of carbon or benzin.

**New Medium for Mounting Microscopical Preparations.**§—According to G. Marpmann, acetyl-cellulose is an ideal medium. It is prepared by treating hydrocellulose with 3 p.c. sulphuric acid at 70° C. and afterwards with acetic acid. On the addition of water acetyl-cellulose separates out and when dried forms a sandy powder which is easily soluble in chloroform, nitro-benzol, &c. As excellent samples are now on the market it is better to purchase.

A good cellulose solution keeps for quite a long time and can always be freshened up by the addition of some more chloroform.

The preparations are removed from alcohol, xylo, or one of the oils (cedar, clove, origanum) to a drop of the solution which has been placed on a slide. Another drop is put on top, and after having been arranged by means of a glass rod a cover-glass is deposited on the surface. The cover-glass may be dispensed with, and this constitutes one of the chief advantages of this medium.

For the cover-glass, cover-slips made of the following solution may

\* Tom. cit., pp. 518–20.

† C.R. Soc. Biol. de Paris, liv. (1902) pp. 1255–6.

‡ Virchow's Archiv, clxix. (1902) pp. 161–2.

§ Zeitschr. angew. Mikr., ix. (1903) pp. 1–3.

be substituted: 10 parts acetyl-cellulose, 1 part aluminium palmitate, 15-20 parts chloroform, 1 part nitro-benzol. The solution is smeared on a piece of plate glass until it forms a layer about 0.15 mm. thick. When dry it can be peeled off in strips and cut up into slips of suitable size.

**Method of Mounting Bacteria from Fluid Media.**—In a communication made at the June meeting, J. A. Hill describes a method of mounting bacteria which is based on the principle of gradually changing the microphytes from aqueous to resinous media.

One volume of the fluid containing bacteria is mixed with two volumes of a solution containing equal parts of glycerin and absolute alcohol and well shaken. The sediment from this is treated with absolute alcohol several times to ensure the removal of all the glycerin and water. The fresh sediment is treated in a similar way with oil of cloves to remove the alcohol. After this the bacteria are stained by replacing this reagent by a saturated solution of fuchsin in oil of cloves. After about a week an equal bulk of balsam dissolved in benzol (undried balsam 1 part, benzol 1 part) is added, and this mixture is treated several times with the balsam and benzol solution to remove the excess of fuchsin. To the final sediment is added about three times its bulk of balsam or styrax mounting medium, and from this last mixture microscopic preparations are made in the usual way.

After each step the fluid is allowed to stand until the bacteria are deposited as a visible sediment; the supernatant fluid is then poured off and the sediment used for the next stage, but the process might be hastened by the use of the centrifuge.

#### (6) Miscellaneous.

**Microscopical Examination of Foods and Drugs.\***—An up-to-date treatise in the English tongue on the microscopical examination of foods and drugs has long been a desideratum. For about fifty years the student of this important branch of science has had to rely mainly on Hassall or on foreign publications. This reproach has now been removed and a long felt want supplied by H. G. Greenish, whose work is specially devoted to instruction in the methods of examining vegetable foods, drugs, and their powders by the aid of the Microscope.

The author has fully succeeded in his task and is to be congratulated on demonstrating that the Microscope is capable of furnishing with the expenditure of a minimum of material, and also often of a minimum of time, information concerning the substances analysed that cannot be obtained by any other means.

The contents are divided into twelve sections arranged so that the student may begin with the simplest and proceed gradually to the complex; e.g. starting with starch, the subject matter deals successively with textile fibres, spores and glands, ergot, woods, stems, leaves, barks, seeds, fruits, rhizomes, and roots. There are two appendices which contain very useful information. The first of these is a list of reagents, with their composition and remarks on their use; the second is a list of the chief varieties of cell-wall and cell-contents, and the means adopted for their identification. The volume is well got up and freely illustrated.

\* J. & A. Churchill, London, 1903, pp. 24 and 321 (168 figs.).

## PROCEEDINGS OF THE SOCIETY.

## MEETING

HELD ON THE 17TH OF JUNE, 1903, AT 20 HANOVER SQUARE, W.  
WILLIAM CARRUTHERS, ESQ., F.R.S., VICE-PRESIDENT, IN THE CHAIR.

The Minutes of the Meeting of the 20th of May, 1903, were read and confirmed, and were signed by the Chairman.

The List of Donations, exclusive of exchanges and reprints, received since the last Meeting, was read, and the thanks of the Society were voted to the Donors.

Livingston, B. E., The Rôle of Diffusion and Osmotic Pressure in Plants. (8vo, Chicago, 1903) .. .. .	From The University of Chicago Press.
An old Non-achromatic Simple Microscope .. .. .	Mr. E. M. Nelson.
Two Micrometers, one with lines $\frac{1}{100}$ in. apart, and the other with lines $\frac{1}{200}$ in. apart .. .. .	" "

Mr. E. M. Nelson, in reply to the Chairman, said that the old Microscope which he had the pleasure of presenting to the Society was interesting because it had a prism focussing bar with a screw at the bottom, and was evidently a very early example of this construction. Although the lens was a non-achromatic one it was remarkably good, and showed the proboscis of the blowfly extremely well; he had been much astonished at the sharpness of the image.

Dr. G. Charlton Briscoe exhibited and described a new portable Microscope of diminutive proportions (see *ante*, p. 543), designed for making microscopical examinations by the bedside.

The Chairman said he had a portable Microscope made for his own use about 25 years ago, by Swift, which packed up into a small leather box that could be carried in the breast pocket of the coat. He carried it about for examining fungal injuries to plants. It was not so elaborate, nor did it contain so many appliances, but it answered admirably the purposes for which it was made. A useable portable Microscope added greatly to the pleasure of a country or seaside holiday.

Mr. F. W. Watson Baker exhibited for Messrs. Watson & Sons a new pattern portable Microscope and also a new mechanical stage. The Microscope was one of their "H" Edinburgh Students' Instruments, fitted with a folding foot. It was somewhat larger and heavier than the one exhibited by Dr. Briscoe, but it had not been designed so much

for use at the bedside, as for the use of persons who preferred to carry a medium size instrument with them when travelling.

The new mechanical stage was of somewhat novel construction, it having three special features, viz. a large horizontal travel amounting to  $3\frac{1}{2}$  inches, a surface perfectly unobstructed, and further the two milled heads, which were mounted on one spindle on the Turrell system, were placed at an angle to the movements of the stage which was not usual.

The stage was specially designed for the use of bacteriologists and those who examine living objects.

The working arrangement was effected by rackwork and pinion of peculiar construction; a sliding bar could be used on the stage if occasion required.

---

**Mr. Beck** said he had brought with him to the Meeting a Spintharoscope, the arrangement by which Sir William Crookes demonstrated the Röntgen rays emitted by radium. This was also made in the form of a microscopic object, but it required to be shown in a darkened room. In a room such as that in which they were meeting, where there were a number of electric lights, it would be very difficult to show, but it was quite easy to see at any time in a room not too brightly lighted.

The Chairman moved a vote of thanks to the three gentlemen to whom the Society was indebted for their interesting exhibitions, all of which presented distinct improvements in the directions which the makers had in view.

The thanks of the Meeting were then unanimously voted.

---

**The Chairman** said the first paper on the Agenda was by Lord Rayleigh, "On the Theory of Optical Images, with special reference to the Microscope." Lord Rayleigh had written to excuse himself from being present, and mentioned that this paper was to be regarded as supplementary to a paper of his which appeared in 1896 in the *Philosophical Magazine*, and at his special request the Council had agreed that the original paper should appear in the Journal along with the supplement, so that the Fellows may have the whole argument before them.

Dr. Hebb then read a portion of this communication, the rest being taken as read.

**Mr. Vezey** said the paper contributed by Lord Rayleigh was a most valuable one, and he felt sure the Fellows would agree that his Lordship had paid a compliment to the Society by making it the medium of his communication. Lord Rayleigh had also kindly permitted the republication of an earlier paper of his on the Microscope, and this would appear in the same number of the Society's Journal as his paper just read by the Secretary, and the value of the latter would be greatly increased thereby. The Society was greatly indebted to Lord Rayleigh.

The thanks of the Society were then, on the motion of the President, cordially voted to Lord Rayleigh for his paper.

---

**Dr. H. Siedentopf** read his paper, "On the Rendering Visible of Ultra-Microscopic Particles, and of Ultra-Microscopic Bacteria," the

subject being illustrated by the exhibition of the objects and apparatus described, specially brought over to England for the purpose, and illuminated by three arc lights arranged upon tables in the room. Further illustration was also given as the paper proceeded, by means of drawings on the blackboard as occasion required.

The Chairman was sure that the Fellows of the Society had listened with the deepest interest to Dr. Siedentopf's exposition of the method by which he had succeeded in making minute objects visible which the highest powers of the Microscope were incapable of disclosing. It was quite impossible for the mind to realise the dimensions of bodies whose size was expressed in such extraordinary figures. He looked forward to important results being obtained from the investigations by Dr. Siedentopf's methods of the structure of the cell-walls of animals as well as plants. He regarded this as the most important paper he had at any time listened to in that room.

Dr. Hebb then read the following communication from Dr. G. Johnstone Stoney, F.R.S.

"If it had been in my power to attend the Meeting, and if I had been asked to speak, I should have wished to say that no particles disseminated through glass *can be too small to be seen* in the Microscope, provided that, however small, they fulfil the two following conditions:—

(1) That the light each particle emits is of sufficient intensity to make it visible.

(2) That the particles are distant from one another by INTERVALS that are not ultra-microscopic.

With an immersion objective of N.A. 1.35 and an immersion condenser of 1.30, both carefully adjusted, and with useless light excluded by a suitable stop, I have found that the practical limit of proximity at which particles *in a row* may be, consistently with our seeing them as separate objects, with indigo-coloured light of about  $0.45 \mu$  wave-length, is somewhere about  $0.20$  or  $0.19 \mu$ —say about the  $\frac{1}{1300000}$  of an inch. This would correspond to seeing *a single pair* of such objects as separate if the interval from centre to centre is about five-sixths of the above—say about  $0.17 \mu$ .

Although a pair of objects can be seen as two, when somewhat closer to one another than the intervals at which a row of such objects must be spaced in order to make it possible to resolve them, it is a curious circumstance, and one which perhaps has not hitherto been taken notice of, that the above *pair* of objects will, in the Microscope, appear to be somewhat farther asunder than they really are.

This, which the present writer ascertained several years ago theoretically, can now be beautifully exhibited by the exquisite rulings which Mr. Grayson has succeeded in producing."

Prof. J. D. Everett desired to call attention to the close connection between Lord Rayleigh's paper and Mr. Siedentopf's experiment. Lord Rayleigh pointed out that no limit could be laid down to the smallness of objects which could be rendered visible, although two objects could not be seen *as separate* if the distance between them was much less than half a wave-length. Mr. Siedentopf's experiment showed that an object with a diameter only a small fraction of half a wave-length

could give a visible image, but it did not exhibit the separation of two objects less than half a wave-length apart. This paper of Lord Rayleigh's was supplementary to a much longer one, published in 1896, containing an exhaustive discussion of the conditions on which resolution by an optical instrument depends. Abbe, in his great paper of 1873 on Microscopic Perception, had laid down, with the promise of a future proof, the law that a grating of fine lines could not be resolved by a Microscope, unless at least two of the spectra given by the grating co-operated in the formation of the image; and that the amount of detail which could be shown in microscopic objects depended essentially on the number of these spectra that co-operated. Lord Rayleigh's paper of 1896 contained the first proof of these assertions; the proof being based on an application of Fourier's theorem. The paper contained a large amount of matter, and some parts of it were very tough reading; but its value as a contribution to microscopic science could hardly be overestimated. The supplementary paper dealt with a kindred subject, and its contention was admirably illustrated by Mr. Siedentopf's brilliant experiment.

Dr. Czapski was also of opinion that the discussion of these three papers might be taken together; he said he would be glad if he could do something to remove some misapprehensions which appeared to exist about the Abbe theory. Lord Rayleigh had shown that the fundament of the Abbe theory of microscopic vision was correct, but there seemed to be an idea that the Abbe theory dealt with nothing else than with the question of resolution. This would always be a matter of great interest to the optician, but what in the majority of cases is of principal interest for the practical microscopist is to know *whether, and to what extent, what they are seeing is a true representation of the real object; and from what conditions as regards construction and use of the Microscope the truthfulness of its working was depending upon.* It was quite true that Prof. Abbe had not published his theory in a somewhat detailed form in writing, but he had given it in his University lectures since 1897-8, and he hoped Prof. Abbe would be able to publish these lectures in good time. He felt quite sure that the new paper by Lord Rayleigh would give the greatest pleasure to all who were able to follow his mathematical demonstrations; his developments were so clear that they imbued one with that sense of beauty which only work of the very highest class does.

It was likewise with a sense of pleasure that he had followed Dr. Johnstone Stoney's work in this connection, which he considered one of the most valuable contributions to the subject.

Mr. J. W. Gordon, being called upon by the Chairman, said he had not intended to take any part in the discussion of this subject, as he was unable to be present sufficient early to hear Lord Rayleigh's paper read. He should, however, like to say by way of personal explanation, that if Lord Rayleigh's paper of 1896 had been in his hands at the time when he was preparing his paper on the Helmholtz theory, he should certainly have made use of it. He explained that the fourth volume of Lord Rayleigh's collected works, containing the reprint of this paper, had only appeared in the present year, and for that reason the

paper itself had been overlooked in his preparation. Adverting to the discussion which had already taken place, he suggested that the remarks of Dr. Czapski and some others who had taken part in it would bear a little further elaboration. They had been discussing the subject of resolution generally, and Prof. Abbe's relation to the diffraction theory had been brought up. It might be of interest, therefore, if he shortly reviewed the labours of the principal workers in that field. The question of diffraction and its effect upon the definition of an image, was first considered by Sir George Airy, who in 1834 attacked this problem:—given a flat wave-front passing through a lens, what effect would diffraction have upon the focussing of that wave-front by the lens? Sir George Airy went no farther. He considers only the case of a simple series of repeated wave-fronts and calculated the light intensity in various parts of the diffraction disc—or antipoint—produced by the aperture of the object-glass. The diffraction of which he took account was diffraction arising from the aperture of the instrument, and the case which he dealt with was the case of light issuing from a single point in the object. So the matter stood until the seventies when the question of diffraction was again treated by Prof. Helmholtz. He dealt with it in a more comprehensive way, for treating not of the telescope but of the Microscope, he had to deal with two diffraction discs, one in the object—that is to say on the stage of the instrument—and the other in the image-plane of the instrument, or, as the case might be, in the observer's eye. But, like Sir George Airy, he discussed the diffraction caused by the aperture of the objective.

Prof. Abbe, on the other hand, spoke of diffraction produced by the structure of the object, an entirely different problem having nothing to do with the discussion initiated by Airy and carried on by Helmholtz.

Then in 1896 came Lord Rayleigh's paper in which, following and carrying on the work of Airy and Helmholtz, he elaborated the mathematical theory of the diffraction which arises from the aperture of the objective, and instead of the diffraction produced by one series of wave-fronts only considered the reciprocal interference of two antipoints or diffraction discs.

Three such cases were separately considered in Lord Rayleigh's paper. In two of them the light was assumed to be polarised in the same plane. In the first case there was supposed to be no difference of phase between two radiant points, and it was shown that if they were no more than half a wave-length apart they would appear to coalesce in the image. In the second case the two radiant points were assumed to be synchronised in opposite phases, and in that case it was shown that there would at the half wave-length interval be complete resolution. A third case was that in which the two undulations were polarised at right angles to one another and there was no direct interference, but the two antipoints overlapped to a certain extent so giving rise to confusion and imperfect resolution in the image. Lord Rayleigh discussed these three conditions, assuming mathematical points for his theoretical resources of light, but he did not enter upon the practical question of the form of the light-intensity curve of the antipoint—when small surfaces were substituted for the mathematical points of his hypothesis. He (the



speaker) supposed that in the supplementary paper read that evening Lord Rayleigh had carried the investigation somewhat further, and had dealt with the light from small radiant surfaces. In the 1896 paper they had a demonstration of what an antipoint was, but not of what an image built up of antipoints would be like.

Except for Helmholtz' paper, so far as he knew, the formation of the images by means of antipoints had not been investigated. Working side by side with Lord Rayleigh there had been Dr. Johnstone Stoney, who had laboured to produce a comprehensive theory in which the diffraction arising from the aperture of the instrument and that arising from the structure of the object on the stage should both be taken into account. Such a scheme presented great difficulties, for the amount of the diffraction arising on the stage depended upon the curvature of the wave-fronts at that point.

If they used plane wave-fronts to illuminate the object they got maximum diffraction, but if they used curved fronts they got more or less diffraction according to the radius of curvature of the incident wave-fronts, and it would follow that they could get rid of this diffraction altogether by focussing the source of light upon the object. Dr. Johnstone Stoney met this objection by contending that they could always resolve the incident light, whatever its origin, into plane wave-fronts, and his very elaborate theory rests upon that postulate.

It was therefore quite true to say that all these investigators deal with the phenomena of diffraction, but it must be remembered when that was said that there are two entirely distinct and independent sources of diffracted light in the Microscope,—the structure of the object, and the aperture of the objective—and that the investigation of the phenomena arising from the one source throws no light upon the phenomena arising from the other source. It is therefore of capital importance to keep the two classes of phenomena distinct in our minds and in our discussions.

-Mr. Rheinberg said he had listened to Mr. Gordon's remarks with great interest; he had given them a record of what different writers had done, but he appeared to think that each had done certain things which did not altogether accord with the results obtained by the others. If, however, they were looked at in a certain way he thought there would be no difficulty in seeing that they came into agreement. They all started with the diffraction by the instrument itself, and this would necessarily be the very smallest amount it was possible to obtain. Diffractive effects in the image, which might occur when an ordinary object was viewed, might *exceed* but *could not be less* in amount than that produced by the instrument pure and simple. What that minimum was, was excellently shown in the case of the ultra-microscopic particles as exhibited in Dr. Siedentopf's demonstration. Mr. Gordon had, he thought, mentioned that Prof. Abbe had neglected the diffraction by the instrument altogether, but this was certainly not the case, for it was dealt with first of all in the book on the Microscope published by Dr. A. Zimmermann, to which reference had formerly been made. It had been most interesting to hear the various papers that evening, and to find that though all had been worked out on different lines, yet they all worked to the same conclusion, and that in this there appeared to be

absolute unanimity. He had been remarkably struck by the manner in which Dr. Siedentopf had excluded all the light except what was diffracted by the actual particles in view themselves, by the device of illuminating only a thin layer of the ruby glass. The study of the effects produced by particles viewed in this manner should add very much to their knowledge of microscopic vision.

Dr. C. V. Drysdale said that he had come there that evening in the attitude of a searcher after truth, as he had previously seen a short notice of Dr. Siedentopf's experiments indicating it should be possible to see the actual molecules. As this appeared to him absolutely impossible he was relieved to find this confirmed by Dr. Siedentopf's statement that it was only clusters of a considerable number of molecules that were rendered visible. He would remind the Members of the Society that there was another limit to the vision of extremely small particles besides any that might be dictated from optical considerations, viz. the intensely rapid motion of the molecules themselves. Should optical means be found of extending the limit of vision down to molecular particles it would be necessary to reduce the temperature of the object under examination to the absolute zero of temperature, and on hearing of Dr. Siedentopf's work he was at first led to wonder whether he had attempted something in that direction. They had been hearing a great deal lately about diffraction theories, and he thought that one very important point had been brought out in the paper under discussion that evening, viz. that although diffraction phenomena prevented the resolution of detail in objects less in size than a half wave-length of light, it did not in any way prevent the detection of an isolated particle, however minute, provided its intensity of radiation was sufficient to affect the retina. He thought that Dr. Siedentopf's demonstration of a new optical limit of visibility was an exceedingly interesting and valuable one.

The simplest way of illustrating the visibility of small objects was to consider an object like a small post fixed near the sea shore. If this object was small in comparison with the size of the waves it was clear that they would unite after passing it, and very little trace would be left on the wave-front of the object having been encountered. It was therefore obviously useless to attempt to seize such small objects by transmitted light, but the waves on striking the obstacle would give rise to ripples radiating from the obstacle in all directions, and it should therefore be possible to see the object in any other direction almost as if it had been self-luminous. Dr. Siedentopf had found it impossible to get results by direct reflected light owing to the reflection from the surfaces, and the great advance which he had made, and which had enabled him to extend visibility so much beyond what others had done, was in his beautiful method of side illumination and especially in concentrating the light into a very narrow beam of depth comparable with the focal depth of the objective. He should like to ask whether Dr. Siedentopf had noticed any difference between the use of violet light as compared with white light in his method.

Finally he would remark that if Dr. Siedentopf's discovery would enable us to see some of those scourges of humanity which had hitherto

escaped detection it would be of the greatest benefit to the race as well as of its present high scientific interest.

Mr. Beilby thought a slight correction was necessary, as it appeared to be thought by some speakers that this was an absolutely new method of observing the particles in ruby glass and in ruby-gold solutions. Faraday satisfied himself forty years ago that the colour was due to the presence of minute separate particles, and one of his methods of verifying this was by concentrating a beam of sunlight through the ruby material, and in this way it was made evident that there were minute particles of gold distributed throughout the glass or solution.

Mr. Beck said it was so seldom that they were favoured with the presence of Dr. Czapski that he thought it would be greatly appreciated if he would inform the Meeting what was, in his and his colleagues' opinion, the effect of Mr. Gordon's work upon the Abbe theory of microscopic vision. In his opinion it was impossible to reconcile the two theories, and Mr. Gordon's work was a direct attack upon the correctness of some of Prof. Abbe's theory.

Dr. Czapski said he was not at all prepared to go fully into the subject of Prof. Abbe's theory, which would take a great deal of time, but Mr. Beck was quite right in saying that Mr. Gordon's first paper had created the impression upon readers not fully informed that Prof. Abbe's theory was wrong, and so it would be useful to go once into the details of that paper. At Jena they had received copies of the paper in June 1901 and had occupied themselves in examining it, but *they found nothing in this very able paper which was in contradiction to the Abbe theory*. The unfortunate thing was that Abbe had never published the full development of his theory, nor had others done so. Prof. Zimmermann's book, alluded to by Mr. Rheinberg, was only a very rough popular sketch of the real theory. This, as he had just said, was given more completely in Prof. Abbe's lectures since winter, 1887-8. If one desires to give an approximate idea of his meanings intelligible even to the non-skilled mathematician or to examine a general theory by experiments, he must use only the most simple conditions, as in this case take for the objects, lines or points (single or double), edges of screens, or periodical structures, for instance gratings. But it would be a thorough misunderstanding of Prof. Abbe's work to think that he has given only a "resolution-theory" or a "grating-theory" of the Microscope. He has treated the problem in its most general form: given certain luminous points arranged on a surface, given another surface (a layer of infinitely small thickness) *in which absorption and refractive index vary after any law whatever*—how can the movement of the ether behind that surface be determined as to phase and amplitude, more especially, how can it be reduced to some most general laws? Further on—and this leads to the special case of microscopical vision: if behind the before-named infinite thin layer (the object) a system of lenses be arranged, of which this layer forms one of its aplanatic foci—what general indications can be given for the distribution of the light in the other aplanatic plane (the image plane)? These investigations, as repeatedly said, were most general with the only restriction that the object is of a (comparatively) very

small thickness. But they led to some very distinct indications about the question which he (Dr. Czapski) believed to be the most interesting: the *correctness* of microscopical vision under the various circumstances and the factors upon which this correctness depended. He (Dr. Czapski) could not go further into the matter then, and regretted that his command of the English language was not sufficient to enable him to express himself as clearly as could be wished, but he should like to have an opportunity at some future time of returning to the subject and of bringing some objects in illustration.

---

Mr. E. M. Nelson gave a brief abstract of his paper on "Micro-metry," showing that the size of the antipoint had to be allowed for, especially in the measurement of minute objects, otherwise an error might be introduced that sometimes amounted to over 100 p.c.

---

The following papers were, owing to the lateness of the hour, taken as read:—"On the 'Lag' in Microscopic Vision" (continued); "An Improved Horse-shoe Stage"; "A Micrometric Correction for Minute Objects"; and "An old Non-achromatic Simple Microscope," by Mr. E. M. Nelson. "A Method of Mounting Bacteria from Fluid Media," by Mr. J. A. Hill.

---

The Chairman said they were greatly indebted to Lord Rayleigh, Dr. Siedentopf, and Mr. Nelson for the very interesting papers read, and to the visitors and Members for the learned remarks made in the discussion on the subject. He also emphasised their indebtedness to the firm of Messrs. Carl Zeiss for sending to England for their inspection the valuable apparatus by which the results of Dr. Siedentopf's investigations and discoveries had been demonstrated to the Fellows.

The thanks of the Meeting were then very heartily voted to the gentlemen referred to.

---

The Meeting was then adjourned to October 21st, and it was announced that the Society's Rooms would be closed from August 14th to September 14th.

---

**New Fellows.**—The following were elected *Ordinary* Fellows:—Messrs. Alfred Chaston Chapman, Raymond B. Fitz-Randolph, and Jas. Wm. Johnson.

---

The following Objects, Instruments, &c., were exhibited:—

The Society:—An old Non-achromatic Simple Microscope, presented by Mr. E. M. Nelson. Two Micrometers, one ruled with lines  $\frac{1}{100}$  in. apart, and the other ruled with lines  $\frac{1}{200}$  in. apart, presented by Mr. E. M. Nelson.

Mr. F. W. Watson Baker for Messrs. Wm. Watson & Sons:—A new Portable Microscope; and a new Mechanical Stage.

Mr. Conrad Beck:—Sir Wm. Crookes' Spintharoscope.

Dr. J. Charlton Briscoe:—A new Portable Microscope.

Mr. J. A. Hill :—Slides of Bacteria, in illustration of his communication.

Dr. H. Siedentopf :—Three Microscopes, fitted with special illuminating apparatus, showing methods of rendering visible ultra-microscopic particles in gold ruby glasses, and in colloidal solutions, also a method suggested for rendering visible ultra-microscopic bacteria.

The following, with other specimens of ruby glass, lent by Dr. Zsigmondy, of Jena :—Copper ruby glass, containing 2 p.c. of copper, originally transparent, 150 times heated and cooled ; this process causing the glass to become perfectly opaque. A gold ruby glass that had been subjected to a high temperature, which had caused small particles of gold to unite and form larger particles, ultra-microscopical objects being thus cemented into microscopical objects. The following gold solutions prepared and lent by Dr. Zsigmondy (all the solutions contained 0.005 p.c. of gold) :—

1. Suspended gold.	Colour of solution, blue.
2. " "	" particles, yellowish-red.
3. " "	" solution, red-violet.
	" particles, yellow.
	" solution, red-violet.
	" particles, gold coloured and green.
4. Cloudy gold solution.	" solution, red-violet.
	" particles, green and yellow, medium size.
	Particles showing vivid oscillations.
5. Colloidal solution of gold.	Particles smaller than $10 \mu\mu = \frac{1000000}{1000000000}$ mm. Particles showing very vivid oscillations.
6. " "	Particles so small that they cannot be rendered visible.

A water-immersion objective D\*, f, 4.4 mm., working distance 1.5 mm., N.A. 0.75.

In connection with Lord Rayleigh's paper, Mr. Gordon writes as follows under date June 18.

"May I ask leave to point out to the readers of the *Journal* the great practical consequence of the result which Lord Rayleigh has now established.

† In a sense, which I propose to illustrate by a familiar instance, the visibility of a dark bar of finite dimensions on a bright uniformly illuminated field is the ultimate condition of resolving power in the Microscope, and a much more proper test than the diffraction grating limit. This will appear from the following example. Under an objective of moderate power the diatom known as *Triceratium Favus* appears as a nearly uniform bright field divided up into hexagons by very fine boundary lines—"dark bars" in the sense of Lord Rayleigh's paper. What the dimensions of these bright areas and limiting lines precisely are I do not know, but I suppose that if I took the bright hexagonal

areas to have a common diameter of  $\frac{1}{4000}$  in., and the dark dividing lines a diameter of one-tenth of that magnitude I should not be far from the mark. Now suppose an object identical in form with *Triceratium Favus* but reduced in scale to one-tenth of the above specified dimensions. We should then have a number of luminous areas separated by distances not exceeding 'say one-eighth of a wave-length of light. Would such a structure be resolved in the image formed by a perfectly corrected objective? That is a question of vital importance to the future of Microscope manufacture, for if the physical nature of light makes it impossible for those dividing lines to be rendered visible in a magnified image we are already very near the final limit of perfection in the objective. But if that delicate tracery is theoretically visible there is still a large area to be conquered by the makers of optical instruments.

Now on this point Lord Rayleigh's results, if I understand them aright, are conclusive. If these boundary lines are to be considered as dark bars on a bright field, they may by suitable illumination be rendered visible and would still be visible, in theory, if their diameters were further reduced to less than one-millionth of an inch.

But this depends upon the area of the bright discs. Are they or are they not large enough to constitute a bright ground, or must they be treated as component parts of a compound structure?

On this point it is not easy to deduce an answer from the paper now under consideration, for although its main results are made perfectly clear the mathematical argument is not fully intelligible without Lord Rayleigh's earlier paper, which is to be reprinted in the number of the *Journal* in which the present paper will appear, but to which I have not present access.

But if I mistake not it will be found that the grating limit applies only when the dark and bright areas have approximately equal diameters, and that any great discrepancy such as is here postulated of 10 to 1—and in fact a discrepancy very much less than that—will bring the case to be considered under the single bar limit and not under the grating limit. It thus appears that the instance which I have put, although it goes much beyond the limit of resolving power, as this is commonly stated by microscopists, is very far from the theoretical limit established by Lord Rayleigh's recent investigation of the subject."

JOURNAL  
OF THE  
ROYAL MICROSCOPICAL SOCIETY.

OCTOBER 1903.

---

TRANSACTIONS OF THE SOCIETY.

---

IX.—*On the Rendering Visible of Ultra-Microscopic Particles  
and of Ultra-Microscopic Bacteria.*

By H. SIEDENTOPF, Ph.D.

(Read June 17th, 1903.)

THE theoretical discussions concerning the capabilities of the Microscope have, following the lines of Abbe and Helmholtz, in the main related to the resolving power of objectives, having established as a limit that structural elements up to a fineness of a quarter  $\mu$  ( $\mu$  = a thousandth of a millimetre) can be resolved. This question of the resolution of structure is for most microscopic research of material importance. It is the aim in microscopy, not only to determine that there *is* a structure in an object under investigation, but above all it is desirable to know what that structure is like. Resolution of structures more minute than those indicated above has not been possible because the light is diffracted by the elements of which the structure is composed.

But the question of the resolvability of a structure is not the only one that can be applied to microscopic observations. There may be cases in which we may have to be satisfied with the simple evidence of the existence of a structure, just as in astronomical research we do not confine ourselves to the observation of the details of the planets, but also seek to render clearly visible very faint, or ordinarily invisible, fixed stars.

Now gold ruby glasses may be said to represent for microscopic research that which the heavens with the fixed stars do for astronomical investigations. These glasses appear perfectly clear and homogeneous to the naked eye, and when tested by the usual microscopic methods show no trace of turbidity. Gold ruby glass is not the only object suitable for these investigations, but all

turbid or colloidal solutions, fixed or fluid, are similarly suitable, provided that the average distance of the single particles is no smaller than half a wave-length.

Let us suppose that the dimension in every direction of these small particles is less than half a wave-length. In that case it is clear that their microscopical images will only be diffraction discs. Now such, for simplicity's sake, will be called "ultra-microscopic" particles; for the expression will at the same time indicate that the resolution of detail in the structure of these particles lies beyond the resolving power of the Microscope.

It might be suggested that mere evidence afforded by such diffraction discs does not sufficiently differentiate the respective particles, and therefore such investigations as the present ones might be treated as superfluous. But I believe that the experiments with gold ruby glasses which I was able to make, at the instigation of, and together with Dr. Zsigmondy, have afforded an optical proof that distribution of gold in these glasses is discontinuous, and have also demonstrated that there are a number of phenomena characteristic of diffraction discs such as colour, order of position, condition of polarisation and brightness, and in fluids also kinds of movement. So many properties seem to warrant a careful diagnosis.

Now, microscopic investigations relating to ultra-microscopic particles cannot be effected by the usual methods. The coloured ruby glasses, in which the distribution of the various particles was demonstrated, showed no sign of their existence when examined in the ordinary way, or even when examined by dark-ground illumination of the usual kind. Under such conditions the glasses appeared perfectly homogeneous. One might almost have expected that these gold ruby glasses in thin slices would have given some indication of heterogeneity, because they might be supposed to be somewhat analogous to stained bacterial preparations.

It was therefore necessary to devise a new method which would permit these small particles to become visible by direct observation as far as possible. The main feature of this method depends upon the regulation and arrangement of the illumination, which, as will be observed, differs materially from that hitherto employed. As in general particles to be optically imaged are not self-luminous in themselves (or where they might be slightly self-luminous the light would be so weak as not to be of any service), we are from the outset compelled to rely upon an artificial light-source of great specific intensity, such as the electric arc or brilliant sunlight.

When this is made to impinge upon the particles they become visible by the cone of rays which they diffract. But the intensity of the illuminating rays is naturally very much higher than that of the rays diffracted by the particles. In order to make smaller



particles visible, therefore, by this diffracted light the illumination must be arranged in such a way that none of the illuminating rays are permitted directly to enter the eye — in other words, all light, except that which is diffracted by the little particles, must be scrupulously excluded. Ordinary dark-ground illumination would seem to be suitable for this purpose; but it is important to note that with the usual dark-ground arrangements, when used with arc or sunlight, innumerable reflections occur at the several lens surfaces of the condensers, and there are besides many inconvenient reflections in the preparation itself (as will be explained more fully further on), so that this kind of illumination will not be suitable for the purpose in question.

If, however, matters are arranged in such a way that the axis of the illuminating cone is at right angles to the axis of the cone diffracted upwards into the Microscope, and if the cones are of such a dimension that no part of the one overlies any part of the other, then all reflections in the condenser are made harmless, and no stray light can now enter the objective. This method is therefore a further evolution of the so-called dark-ground illumination, and permits us to use the brightest sources of light.

Another illustration may be mentioned to make this clear. It is well known that small particles of dust floating in the air become visible as soon as a beam of sunlight is allowed to enter through a hole in a dark room, provided the observer's eye be approximately at right angles to the beam.

If now the illumination over a small area is increased by focussing a sunbeam by means of a condenser, and if the particles in this area are observed by a Microscope, then we have the principle of this simple method.

Optical images of ultra-microscopic particles are polarised diffraction discs, in other respects they are subject to the same condition as images of stars in telescopes.

It is not difficult to explain why this device enables particles in gold ruby glasses to become visible, while ordinary methods do not. Let me remind you that a high power objective only reproduces a sharp image of an exceedingly thin layer of an object. Now, with ordinary methods of illumination a great number of layers above and below a focussed layer receive light, and numberless particles lying in all these layers diffract light up into the objective. As these particles are out of focus they appear in the image-plane as discs of diffused light. As these diffusion discs overlap one another in the image plane they form a veil of light sufficiently powerful to completely eclipse the small diffraction discs representing the particles in the layers actually in focus.

It is therefore of vital importance to illuminate only those *particles which are to be made visible*, and the method of doing this is by focussing the arc light upon a small spectroscopic slit, the

light from this slit being focussed by a condenser upon those particles which are to be made visible. The size of the slit can be precisely controlled, and, with a knowledge of its width and of the condensing system employed, the exact thickness of the layer of illuminated particles can be regulated to a nicety. It will be found convenient to adjust the thickness of this illuminated layer to about 1 or 3  $\mu$ , so that it may correspond with the depth of focus of the objective.

We will now examine the limit of the smallest size of particles which it is possible to render visible by this method. The following considerations will help us to solve this question, at least approximately. It is known that radiation from a surface depends on three main factors—first, on the specific intensity of radiation; secondly, on the area of the radiating surface; thirdly, on the solid angle at which the radiation is emitted from the surface. This amount of energy can be expressed in terms of candle-power, and the limit of sensitiveness of the human eye for light is also known. From these two quantities, namely, the limit of least sensitiveness of the eye, and the limit of the greatest radiation which can be obtained by diffraction from the particles, we are in a position to determine the limit for the smallest dimensions which can be made directly visible. Within the scope of practical experiments this limit approximately works out at forty square millionths of a millimetre, which therefore corresponds to a circle of a radius of about  $\frac{4}{1000000}$  mm.\* It is of particular interest to note that the result of these practical observations appears to approach very nearly to the theoretical limit of visibility of the minutest particles.

Now, it may be taken for granted that with no artificial illumination, however intense, will it be possible to discern with the human eye dimensions so small as those attributed to medium sized molecules (about 0.6  $\mu$   $\mu$ ). Even if we were to succeed in making the molecules self-luminous by any conceivable process, the specific intensity of the luminosity would have to considerably exceed the power of the sun's rays, a feat decidedly improbable.

Permit me here to mention that I particularly wish to guard against any over-estimation of the capabilities of the methods exhibited to-night. In particular I would wish to repeat that the procedure in question does not give any optical solution of the *true shape and size* of the small particles. Whatever their form may be you will always obtain a small diffraction disc as the image. Only when an ultra-microscopic particle is so much enlarged that one of its dimensions exceeds half a wave-length (in other words when it in part passes out of what may be called

\* H. Siedentopf und R. Zsigmondy, 'Über Sichtbarmachung und Grössenbestimmung ultramikroskopischer Teilchen mit besonderer Anwendung auf Goldrubingläser.' Ann. d. Physik, x. (1903) pp. 1-39. Diam. = .008  $\mu$ .

the ultra-microscopic condition) can we differentiate it under the Microscope as a rod, a thread, or an elliptical disc.

Diffraction discs of various particles show according to their size and formation great differences in brightness and colour.

I may further mention that we were able to demonstrate small particles in gold, silver and copper because the refractive indices of these metals were essentially different from the medium in which they were imbedded. As regards the oxides of organic bodies, such as are contained in colloidal solutions of silicic acid ( $\text{SiO}_2$ ), oxide of alumina ( $\text{Al}_2\text{O}_3$ ), and albumen, our method is not as yet applicable, doubtless because the refractive indices of these bodies do not differ sufficiently from those of the medium in which they are contained.

No doubt the question will present itself to your minds, whether this method of illumination can be applied with advantage to the investigation of cellular tissues, &c. Up to the present, so far as time has permitted for experiment in this direction, I must own that the result is a negative one; this, however, by no means precludes the possibility of something being done in the future. But experiments with ultra-microscopic bacteria have been more promising, and although at present I cannot say for certain that such *ultra-microscopic bacteria* have actually been viewed, I think I may say that *my experiments point to the perfect feasibility of making them visible, so that bacteriologists may actually discover germs which have been suspected to exist.*

I will therefore give you a short description of the special device which I have designed for this purpose, and which, whilst differing in application from the method previously described, carries out the principle of dark-ground illumination in another manner.

Bacteria are made visible solely by the light they diffract: and they appear as luminous discs on a dark ground because the direct illuminating rays are stopped out.

In the arrangement for this purpose the axis of the illuminating cone of light, and that of the rays diffracted by the object, are in a straight line, and not at right angles to each other, as in the other methods. Preparations of bacteria can therefore be mounted in the usual way. The direct illuminating rays are stopped out by a method, suggested by Abbe, viz. by grinding flat and blackening a small central portion of the curved surface of the front lens of the objective. The portion ground away is exactly calculated to suit the aperture of the illuminating objective. The technical execution of this method requires very great precision, but special advantages are secured thereby. In the first place, reflections can no longer occur between the lenses; secondly, the tedious centring for dark-ground illumination is obviated; thirdly, a stop made like

this cannot be decentred; and lastly, the objective remains available also for observation in the ordinary way without dark-ground illumination; one may even say that it must give better images than it did before the central portion had been stopped out, because according to the laws of the diffraction theory, a diffraction disc produced by an annular opening of *suitable* dimensions is even somewhat smaller than that formed by the full aperture under similar conditions.

An alteration has been made in the mount of the condenser which enables a convenient and rapid change to be effected from an optical system of 1.4 N.A., as used for the usual illumination of bacteria (after Dr. Koch), to another optical system consisting of an objective specially corrected and stopped down to a small aperture by which a dark-ground illumination is obtained, and which allows sunlight or arc light to be directly employed.

On the table here I have a preparation of ordinary cholera bacillus shown by this method. It will be noticed how thick and pronounced the appearance of the exceedingly fine flagella has become. But it is not this to which I would draw your attention so much as to a number of bright discs representing something which lies in the same thin layer on which the objective is focussed, but which cannot or can scarcely be seen by ordinary methods of observation. Ultra-microscopic bacteria might be expected to look something like this, though of course, I do not intend to suggest that there are any in the preparation on view.

In conclusion I must point out that these investigations have been materially assisted by the liberal manner in which all the necessary means were placed at our disposal by the firm Carl Zeiss of Jena.

X.—*A Micrometric Correction for Minute Objects.*

By EDWARD M. NELSON.

*(Read June 17th, 1903.)*

Most microscopists are aware that the magnified image of an object is made up of diffraction discs, to which Mr. Gordon has given the appropriate name of "antipoints"; they will agree therefore that some notice must be taken of the size of these discs when the micrometry of minute objects is performed.

A reference to fig. 139 will make this clear. A and B are the webs of a micrometer. The large circle represents the true magnified image of the object: this is never seen; the small circles

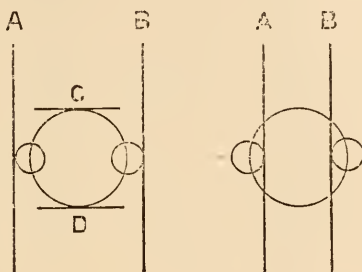

FIG. 139.

FIG. 140.

are the antipoints. It is obvious that if the true size CD of the magnified image is required it will be necessary to subtract the diameter of one antipoint from the measure given by AB. In this case the object is illuminated on a dark ground.

Fig. 140 shows the same magnified image of the object illuminated on a bright ground; here the antipoint eats into the edge of the image and the measurement AB must be augmented by the diameter of one antipoint before the true size of the image can be known.

The only datum required is the size of the antipoint. A glance at figs. 139 and 140 shows that it is half the difference of the two readings of the webs AB.

The effect of the antipoint on the magnified image can be very easily demonstrated; take, for example, the proboscis of the blowfly, and examine with a  $\frac{1}{2}$ -in. objective the very minute hairs on, or protruding beyond the edge of the delicate membrane; illuminate them first on a bright field by a  $\frac{2}{3}$  cone; now notice the almost

unreal sharpness and tenuity of the hairs; next place a stop at the back of the condenser and view the same hairs on a dark ground, when they will be found to present a swollen or thick appearance. The true shape of the hairs lies of course between these two microscopical pictures.

The size of the antipoint is governed by the wave-length and by the size of the utilised or working aperture of the objective, in other words by  $\lambda$ , and W. A.\*

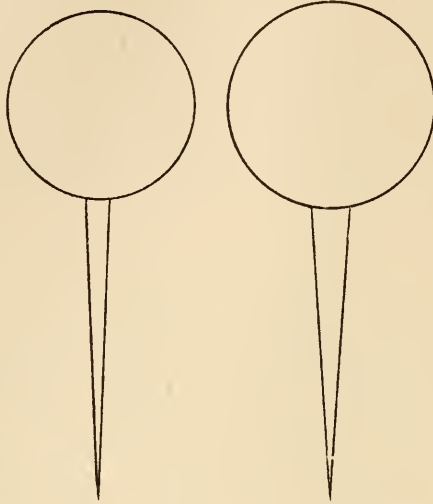

FIG. 141.

FIG. 142.

The following table gives the amount to be added to the size of the image on a bright field, or subtracted from the size of the image on a dark field when accurate determinations of the magnitude of minute microscopical objects is required.

The first column is for white light, the value of  $\lambda$  being the latest measurement by Mr. J. W. Gifford of the point of maximum intensity in the spectrum. The second column is to be used when a Gifford or similar screen is employed,  $\lambda$  being taken for a point between the lines E and F. The third column is for photographic work. To illustrate the method of applying this correction, let us take the measurements of the *Bacterium termo* and its flagellum by Dr. Dallinger.† The mean of 200 measurements gave  $\cdot 000004885$  ( $\frac{1}{204700}$ ) in. for the thickness of the flagellum, and  $\cdot 00004885$  ( $\frac{1}{20470}$ ) for the diameter of the *termo*. Now,

\* For the method of determining the W.A., see J.R.M.S., 1901, p. 244.

† J.R.M.S., 1878, p. 175, pl. 8, fig. 1, pl. 9, figs. 10, 11, 12.

assuming that the W. A. was  $\cdot 8$ , we have from column 1 the correction  $\cdot 00000505$  to be added to each of those measurements; this gives  $\cdot 00000993$  ( $\frac{1}{100700}$ ) for the size of the flagellum, and  $\cdot 0000539$  ( $\frac{1}{18550}$ ) for the diameter of the *termo*. Fig. 141 is a diagrammatic representation of Dr. Dallinger's measurements enlarged 20,000 times. Fig. 142 is the same after the correction has been applied; it will be noticed that the body of the *termo* is increased

TABLE SHOWING THE AMOUNT OF CORRECTION TO BE APPLIED TO THE APPARENT MEASUREMENT OF MINUTE OBJECTS.

The correction for objects measured on a bright ground is +  
 " " " dark\* " -

W.A.	White Light, 45,300.†		Screen, 50,000.†		Photography, 63,500.†	
	inches.	$\mu$	inches.	$\mu$	inches.	$\mu$
·1	·0000404	1·025	·0000366	0·929	·0000288	0·731
·2	" 202	0·512	" 183	·464	" 144	·366
·3	" 135	·342	" 122	·310	·00000960	·244
·4	" 101	·256	·00000914	·232	" 720	·183
·5	·00000807	·205	" 731	·186	" 576	·146
·6	" 673	·171	" 610	·155	" 480	·122
·7	" 577	·146	" 522	·133	" 411	·104
·8	" 505	·128	" 457	·116	" 360	·0914
·9	" 449	·114	" 406	·103	" 320	·0813
1·0	" 404	·102	" 366	·0929	" 288	·0731
1·1	" 367	·0932	" 332	·0844	" 262	·0665
1·2	" 336	·0854	" 305	·0774	" 240	·0609
1·3	" 311	·0788	" 281	·0714	" 222	·0562
1·4	" 288	·0732	" 261	·0663	" 206	·0522
1·5	" 269	·0683	" 244	·0619	" 192	·0488

† Number of waves to the inch.

by 10 p.c., and that of the flagellum by 100 p.c. From this it will be understood how erroneous the micrometric measurement of very minute objects must be, unless some allowance has been made for the influence of the antipoints by which the magnified image is formed.

The figures in the above table give the size of the antipoint and indicate the minimum visible for objects on a bright ground.

\* On account of the super-amplification of those layers of an object which are not strictly in focus, and also on account of irradiation, the apparent measurement of objects on a dark ground is not to be relied upon, so this correction, which for objects on a dark ground is only a rough approximation, will not be needed.

The above table was computed by the formula  $\frac{1}{5 \cdot 4686 \lambda \text{ W. A.}}$ . The numerical coefficient was determined from the data found by the extinction of the image of a minute point by reducing the W. A. to  $\cdot 165$ . The size of the point was measured by a wide-angled oil-immersion, and a W. A. of  $\cdot 9$ , and was found to be apparently  $\frac{1}{50050}$  inch.

From this we have  $6 \cdot 6961 \lambda \cdot 165 = 50050$ . And  $\frac{1}{6 \cdot 6961 \lambda \cdot 9} = \cdot 000003663$ . Employing this as a provisional correction, we find the size of the point to be  $\frac{1}{42396}$  in. Again, using this measurement, we obtain a new numerical coefficient, viz.  $5 \cdot 6587$ , and finally find the size of the point  $\frac{1}{40875}$  in., and the coefficient  $5 \cdot 4686$  as stated above. In this calculation  $\lambda$  is the reciprocal of the wavelength, or the number of waves per inch, given at the head of each column in the table.



XI.—On the “Lag” in Microscopic Vision—(continued).

By EDWARD M. NELSON.

(Read June 17th, 1903.)

THIS continuation of my former paper,\* is mainly of antiquarian interest, as it deals with early non-achromatic and achromatic objectives. For the benefit of those who have not that paper before them, it may be as well to recapitulate, very briefly, the meaning and the method of estimating both the “Lag” and the “Order of Merit” in an object-glass.

First, it was explained, that as the measure of the limit of ordinary unaided vision was the tangent of the visual angle for a minimum visible, so the measure of the limit of either microscopic or telescopic vision was the tangent of the similar microscopic or telescopic angle. For example: if an interval of 1 in. can just be seen by unaided vision at a distance of 10 yards, then with a perfect telescope, having a power of 10, the same interval ought to be seen at a distance of 100 yards, in which case there would obviously be no “lag”; because the optical instrument was doing precisely what it ought to do, and what might reasonably be expected of it. Therefore if  $\tan v$  represents the tangent of the visual angle, and  $\tan m$  that of the telescopic angle, then, in the example above, the “lag” or

$$\tan m - \tan v = 0,$$

thus indicating that the optical instrument, when its amplifying power is taken into account, in no way lags behind unaided vision.

But it was pointed out, that with telescopes, and those not particularly good ones, it had been observed that sometimes they performed better than might be expected of them, and in the example just given, the distance at which the 1 in. interval might be separated with a power of 10 was found, for some unexplained reason, to be increased to 110 or 120 yards, in which cases the “lag” became a negative quantity,

or 
$$\tan m - \tan v = -\alpha.$$

But when the power was increased, owing no doubt to the super-amplification of optical imperfections, the “lag” sometimes became a positive quantity, thus, if a power of 100 were employed, the

\* Journ. R.M.S., 1900, p. 413.

1-inch interval would not be perceived at 1000 yards, but at, say, 900 yards, in which case

$$\tan m - \tan v = + b.$$

We now come to the "order of merit"; this is merely the tangent of the visual angle divided by the tangent of the similar instrumental angle, thus, in those instances where there is no "lag," when  $\tan m = \tan v$ ,  $\frac{\tan v}{\tan m} = 1$ ; but, when the instrument was performing relatively better than unaided vision,  $\frac{\tan v}{\tan m}$  would be greater than 1; and when worse less than 1.

Lastly, to clear the table of decimals and initial decimal points, the quantities  $m$  and  $v$  were multiplied by one million; also the formula for the "order of merit" was written  $\frac{10 \tan v}{\tan m}$ .

Further, it was pointed out that this last formula might with advantage be altered empirically to

$$\frac{10 \tan v}{\tan m - \text{O.I.} - t}.$$

Where O.I. stands for the optical index, and  $t$  for the number of thousands of lines to the inch resolved. Finally, the optical index is the ratio of the numerical aperture to the initial magnifying power, thus

$$\text{O.I.} = \frac{1000 \text{ N.A.}}{\text{initial power}}.$$

For the benefit of non-mathematical readers, the value of  $\tan v$  is found by dividing the least interval separated by unaided vision by the distance at which it is separated. (*Note.*—This should be determined in very bright daylight.)

Example:  $\frac{1}{50}$  inch can be separated at  $45\frac{3}{4}$  inches, then  $\tan v = \frac{\cdot 02}{45 \cdot 75} = 0\cdot 000437$ , this multiplied by one million = 437, the value assigned to  $v$  in the following tables.

To find  $\tan m$ , multiply the magnifying power  $P$  (total combined magnifying power when an eye-piece is used) by 100, and divide by the *number* of thousands of lines resolved.

Example: with 36 power, 8000 lines to the inch could be resolved, then,  $\frac{3600}{8} = 450$ .

The "lag" therefore is  $450 - 437 = + 13$ .

In this case, the O.I. was found to be 19, therefore

$$m - t - \text{O.I.} = 450 - 8 - 19 = 423,$$

and the "order of merit" is

$$\frac{4370}{423} = 10.3.$$

If any one desires to avoid the empiricism in the last formula, and prefers the simple theoretical value, then the formula  $\frac{10 \tan v}{\tan m}$

should be used. This in the above example is  $\frac{4370}{450} = 9.7$ .

In these experiments the illumination for the non-achromatic objectives in the first group was a full axial solid cone, and for the Tulley achromatics in the second group a  $\frac{5}{8}$  cone was employed.

The plate was ruled by Mr. H. J. Grayson, of Melbourne, and was mounted in realgar of 2.5 refractive index.

Objective.	Nominal Focus.	O.I.	Eye-piece.	P.	t.	m.	m-t-O.I.	"Lag."	Order of Merit.
Ross single bi-convex	1	12.7	none	10	2	500	485	+63	9.0
"	$\frac{1}{2}$	5.6	"	20	5	400	390	-37	11.2
"	$\frac{1}{4}$	3.2	"	40	8	500	489	+63	8.9
Pritchard doublet	$\frac{1}{2}$	4.9	"	20	5	400	390	-37	11.2
" "	$\frac{1}{6}$	2.6	"	60	10	600	587	+163	7.4
Chevalier doublet	$\frac{1}{4}$	3.9	"	36	8	450	438	+13	10.0
" "	$\frac{1}{10}$	2.5	"	100	15	667	650	+230	6.7
" "	$\frac{1}{10}$	3.1	"	160	25	640	612	+203	7.1
Wollaston doublet	$\frac{1}{17}$	1.6	"	172	20	860	839	+423	5.2
Tulley triple	$1\frac{1}{2}$	14.9	A	32	7	457	435	+20	10.0
" "	$1\frac{1}{2}$	14.9	B	45	8	563	540	+126	8.1
" "	$\frac{9}{10}$	18.9	A	36	8	450	423	+13	10.3
" "	$\frac{9}{10}$	18.9	B	50	10	500	471	+63	9.3
Combination	1	14.8	A	50	10	500	475	+63	9.2
Two triples	$\frac{1}{2}$	12.2	A	127	20	635	603	+198	7.2
Combination	$\frac{2}{3}$	9.2	A	87	10	870	851	+433	5.1
Two triples	$\frac{1}{4}$	9.2	A	182	15	1212	1188	+775	3.7
Combination	1	17.4	A	47	10	470	443	+33	9.8
Achromatic	$1\frac{1}{2}$	23.0	A	37	10	370	337	-67	13.0
Semi-apochromatic	$\frac{1}{4}$	19.0	A	150	40	375	316	-62	13.8
" "	$\frac{1}{4}$	19.0	B	200	50	400	331	-37	13.2

An examination of the first group of lenses in the above table shows the fairly high position taken by non-achromatic lenses; this may be accounted for by the absence of all superamplification, for if they had been used with an eye-piece a very different result would have been obtained.

It will be noticed that the  $\frac{1}{2}$  inch, both single and double, wins the greatest number of marks, and it is here where the high watermark was reached in pre-achromatic days. In the higher powers the doublets surpass the singles, and the Chevalier doublet is the best, for the Chevalier doublet  $\frac{1}{4}$  is one above the single, and the  $\frac{1}{16}$  is two above the Wollaston doublet of nearly the same power, and the  $\frac{1}{10}$  is not one behind the Pritchard  $\frac{1}{6}$ , although it is a much higher power.

Passing on to the second group of lenses, viz. early Tulley achromatics,\* we see that the lower powers have a fairly large O.I., and come out better than one would have expected. With the B eye-piece, however, the  $1\frac{1}{2}$  inch loses 2, but the  $\frac{9}{10}$ , the best of the series, only 1.

The combinations lose 2 when the front is put on. The back of the last combination is fairly good with 9·8 marks, but the  $\frac{2}{3}$  and  $\frac{1}{4}$  combination is especially bad, the last only obtaining 3·7 marks.

Three examples extracted from the table in my previous paper are inserted at the end for purposes of comparison. The achromatic  $1\frac{1}{2}$  (1860) corresponds very nearly in power with the Tulley, but its O.I. is 8 more, and it scores 3 more marks. The semi-achromatic  $\frac{1}{4}$  has 10 more O.I., and wins besides 10 more marks than the Tulley, and only loses 0·6 with the B eye-piece.

This table therefore shows at a glance the advance made in the construction of Microscope lenses since 1830.

These Tulley combinations are interesting as they are very early, if not the earliest examples of separating achromatic lenses, the construction of which passed on from Tulley to Smith. It will be remembered that it was Smith who, in 1841, made the separating lenses for the Microscope purchased by the Society, which are still in our Cabinet. Another interesting feature is that the gauge of Tulley's screw is very nearly the same as that of the Society's screw, so that Tulley's objectives will enter and screw into our nose-piece, but Tulley's nose-piece is a trifle too small for the Society's plug to enter.

\* For an account of these lenses see Journ. R.M.S., 1902, p. 16. The  $1\frac{1}{2}$ ,  $\frac{9}{10}$ , and the back lenses of the combinations are similar to the Göring-Tulley triple of 1824. The fronts of the combinations are higher powers of the same form. The front lens of the last combination was out of adjustment, therefore could not be examined.

## NOTES.

*An Old Non-Achromatic Simple Microscope.*

By EDWARD M. NELSON.

THIS simple Microscope, fig. 143, consists of a triangular prismatic limb, attached to a turned ornamental pillar by a compass joint; concentric with this compass joint is a slotted semicircular brass plate with a clamping screw, to clamp the limb at any required

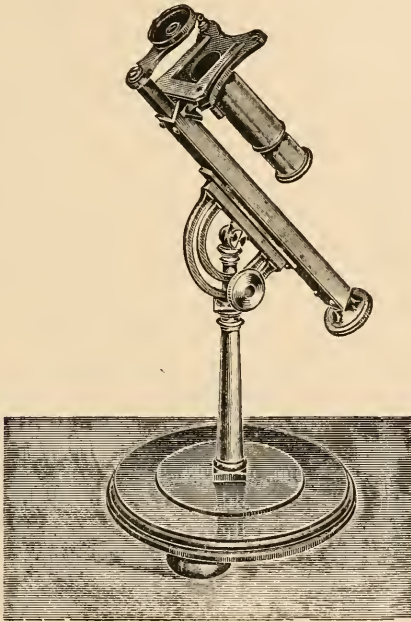

FIG. 143.

inclination. The pillar is fixed to a circular brass base resting on three feet.

The stage has a rectangular clip with two pins fastened below it which pass through two holes in the stage. This form of stage clip first appeared in Jones' Most Improved Compound Microscope\*

\* George Adams, 'Essays on the Microscope'; the date on Plate 4 is 1797.

and lasted many years, for it is found in the Lister-Tulley,\* the first achromatic Microscope, and again in the Ross-Valentine,† and we still find it in the Ross dissecting Microscope ‡ of 1855.

We now pass on to the triangular prismatic limb. The first Microscope to have a triangular limb was the large Benjamin Martin Microscope, in our Cabinet, the date of which may be placed at 1770. This limb was fixed, and the stage, for the instrument was a stage focusser, racked up and down upon it. The next time we hear of a triangular limb is in Varley's description § of a "Microscope for live Objects," this instrument was made by Powell. Although, for reasons stated, Varley did not apply the triangular limb to his Microscope, he says, "my late uncle about thirty years ago introduced the triangular bar and triangular tube. . . ."

In Valentine's Microscope, made by Ross (1831), the triangular limb, however, is reintroduced. Again we have it in Pritchard's Microscope, figured in his *Microscopic Cabinet* 1832; this Microscope was made by Powell, and was a modification of Varley's. So we see that Varley suggested the reintroduction of the triangular limb, Ross first adopted it in Valentine's Microscope, and Powell, following Ross' lead, used it in the Microscopes he made for Pritchard.

There is no coarse adjustment, but a fine adjustment screw, placed at the bottom of the limb, acts directly on the triangular focussing bar. This part is copied from Varley's Microscope, but, as his sprung nut || is omitted, the loss of time is very great.

Beneath the stage is a sub-stage condenser in a sliding tube fitting; its optical part consists of a sliding convex lens.

The objective is a single bi-convex lens of 1 in. focus; it is mounted precisely like the Wollaston doublets of that period. The gauge of the mount is 0.618 in., and some similar, but signed, examples of Andrew Pritchard were found to vary between 0.614 and 0.619. The foot is circular; we find that Microscopes on circular feet are figured in the second edition of Pritchard's *Microscopic Illustrations*, 1838, pp. 82 and 88, figs. 11 and 12.

I have examined the tongue of a blow-fly with this instrument, and was quite surprised at the high quality of the image.

This Microscope was probably made by Powell for Andrew Pritchard, circa 1835-40.

This instrument possesses two points of interest.

1. It is an undoubted early example of the reintroduction of the triangular focussing bar.

2. It is also an early example of a circular foot.

\* Journ. R.M.S., 1900, p. 551, fig. 146.

† Op. cit., p. 425, fig. 104.

‡ Idem, p. 428, fig. 109, and Quart. Journ. Mic. Sci., vol. 3, p. 220, fig. 15.

§ Trans. Soc. of Arts, vol. 48, p. 12 (1832), and Journ. R.M.S., 1900, p. 283, figs. 70, 71.

|| Journ. R.M.S., 1900, p. 284, fig. 72.

I have much pleasure in offering this instrument to the Society for its Cabinet.

As the evolution of the prism bar has been alluded to above, it might not be out of place to append a diagram of the section of the various bars.



FIG. 144.



FIG. 145.



FIG. 146.



FIG. 147.

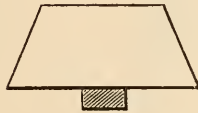

FIG. 148. }

1. Benjamin Martin, with internal rack, 1770, fig. 144.
2. Ross-Valentine, angles slightly truncated, 1831, fig. 145.
3. Powell's, a cylindrical bar with three faces planed off, 1833, fig. 146.
4. Powell's next form was merely an enlargement of fig. 145, 1843.
5. Ross abandons the triangular for a rectangular parallelepiped, 1851, fig. 147.
6. Powell's truncated prism, now in use, 1861, fig. 148.

In the above figures, the shaded portion in each case represents the rack.

*An Early Compound Microscope with a Mirror attached to its Limb.*

By EDWARD M. NELSON.

THIS old Microscope will on examination be found to possess some points of interest. A very cursory glance at fig. 149 shows that it is home-made by some ingenious amateur. The body is composed of three brass tubes sliding into each other. These obviously were not intended for draw-tubes, but merely for the convenience of fixing the lenses in their proper positions. The lenses are held in their place by split wire rings; the diaphragms are made of cardboard. The lenses are four in number, two of which form a Huyghenian eye-piece, the third being the back lens of the objective, after the plan introduced by Benj. Martin.

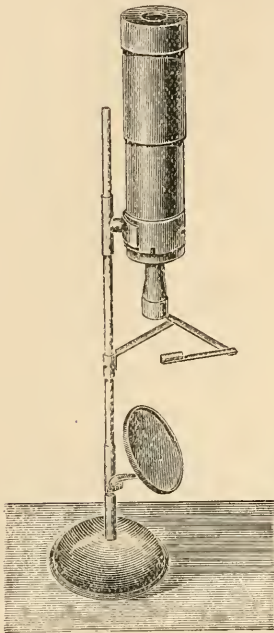

FIG. 149.

The limb is merely an iron rod, attached to a heavy circular foot. The stage is elementary in the extreme: it has a socket to hold the stage forceps, but a slip can be laid across the bars when they are bent round. The objective merely pushes on to the nose-piece without any screw.

The ball and socket for the mirror is of a very simple and ingenious construction, and it will be noted that the mirror is attached to the limb. This is an important point, for it took some years to arrive at the obvious improvement of attaching the mirror to the limb.

The mirror was first applied to the Microscope by Hertel in 1715, but then, as also in the Culpeper and Scarlet (1738), and John Cuff (1744), the mirror was attached to the box-foot. We first meet with a mirror attached to the limb in a *simple* Microscope, viz. that of Lindsay\* (Invented 1728, Patented 1743); a signed, dated (1742), and numbered (No. 22) example being in our cabinet. The next instance where we find it is in Ellis's Aquatic Microscope,† 1755; but the example before you is probably the

\* Journ. R.M.S., 1895, pl. 4, p. 257.

† Figured in many books besides Mr. Ellis's work on *History of Corallines*; probably the most accessible is *Adams on the Microscope*, 1798, pl. 7 B.



earliest *Compound Microscope* that has its mirror attached to the limb.

In fixing the date of this *Microscope* we can assume that it is an instrument made by an amateur on the lines of some model before him. Now the *Microscope* he has evidently copied is that of Benjamin Martin (1760–1770)\*; a signed and numbered (No. 1) example of which is in my possession.

It probably is not older than 1715, the date of the introduction of the mirror, neither earlier than 1760–1770, because its object-glass has a back lens; but, evidently, it is an old instrument made in the latter half of the eighteenth century. I have much pleasure in offering this instrument to the Society for its acceptance.

### *An Improved Horseshoe Stage.*

By EDWARD M. NELSON.

WHILE working with a high power on a *Microscope* with a plain stage, having only a circular hole in it, great inconvenience was experienced in tilting the slide on its edge, for the purpose of feeling the working distance, when bringing the lens into focus; it therefore occurred to me that it would be a good plan to cut away all the brass in front of the circular hole and make what is now known as a "horseshoe stage." So in 1880, I asked Powell to cut out the stage of his iron *Microscope* † for me. The advantage was at once so apparent that I had three other instruments treated in the same manner. ‡

This form of stage is now largely used. Although the advantage of this form of stage when ordinary slides are being examined is obvious, yet some objection may be raised when dishes and watch-glasses with convex bottoms are placed upon it, because of their liability to slide forward in the horseshoe opening. I have therefore designed this simple modification which will render this form of stage suitable for all purposes.

A flat plate of brass with a circular hole in it, having tongues at the edges to slide in grooves cut to receive them, is pushed into the horseshoe opening, when dishes, etc. are required to be placed upon the stage. When ordinary slides are to be examined the brass plate is withdrawn, and the horseshoe stage is left in its original condition.

\* Journ. R.M.S., 1898, p. 474, fig. 81.

† Idem, 1899, pp. 209, 210, figs. 44 and 45, and 1900, pp. 289–291.

‡ Idem, 1883, p. 554, fig. 94; and 1887, p. 293, fig. 41, and p. 1013, figs. 238 and 239.

Fig. 150 (scale  $\frac{1}{2}$ ) shows the horseshoe stage with the brass plate *in situ*, and fig. 151 shows the brass plate when withdrawn. In fig. 150 the X shows the optic axis, and it will be noticed that from the X to the top of the sliding bar is  $1\frac{1}{2}$  in. (38 mm.), which is equal to the distance from the X to the top of the stage; therefore a slide  $1\frac{1}{2}$  in. (38 mm.) wide can be examined from its

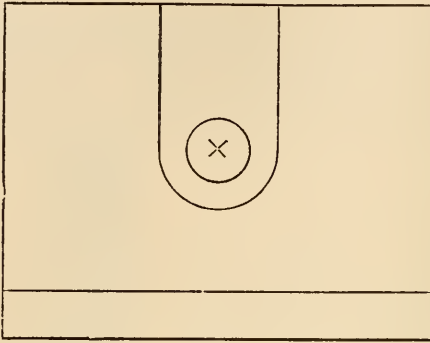

FIG. 150.

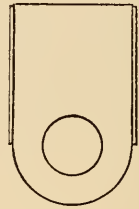

FIG. 151.

top to its bottom edge; also  $\frac{3}{4}$  of an inch (19 mm.) of sideway movement can be given to a slip 3 in. (76 mm.) long, on each side, without causing the end to project beyond the stage. This means that a  $1\frac{1}{2}$  in. (38 mm.) square on a slide measuring 3 by  $1\frac{1}{2}$  (76 by 38 mm.) can be searched over without any portion of the slip projecting beyond the edge of the stage. The two lines at the bottom of fig. 150 indicate the sliding bar, but the lugs are not shown.

SUMMARY OF CURRENT RESEARCHES  
RELATING TO  
ZOOLOGY AND BOTANY  
(PRINCIPALLY INVERTEBRATA AND CRYPTOGAMIA),  
MICROSCOPY, ETC.\*

---

ZOOLOGY.

VERTEBRATA.

a. Embryology.†

**Influence of Salt Solution on Early Development of Newt's Egg.**‡—W. Tonkoff finds that very weak solutions (.5 p.c.) inhibit the development, without causing special abnormality in the cleavage. Stronger solutions (.6–.7 p.c.) not only inhibit, but modify the development. The difference in size between the cells of the two hemispheres is accentuated; the surface of the upper hemisphere is very uneven; the gastrulation is irregular. In .8–.9 p.c. solutions, there is no gastrulation, cleavage is almost restricted to the upper hemisphere, there is almost no blastula-cavity, the nuclei show signs of degeneration, and so on. In 1 p.c. solution only a few cleavages occur.

**Artificial Fertilisation of the Ova of *Cristiceps argentatus*.**§—Fr. Kopsch describes the comparatively easy way in which the ova of this small Blenniid can be artificially fertilised by spermatozoa. This is of some scientific interest since the eggs of this fish are relatively large and very transparent,—therefore admirably suited for morphological and physiological study.

**Spermatozoa of *Acanthias vulgaris*.**||—G. Retzius describes a spiral band wound around the head of the spermatozoon and apparently running into the apex. It is very resistant and was disclosed by maceration. Sometimes there were two parallel spirals. Retzius also finds inside the “connecting-portion” of the spermatozoon a spirally coiled thread, which is apposed to the distal centrosome-ring and is interpreted as a proximal centrosome.

\* The Society are not intended to be denoted by the editorial “we,” and they do not hold themselves responsible for the views of the authors of the papers noted, nor for any claim to novelty or otherwise made by them. The object of this part of the Journal is to present a summary of the papers as *actually published*, and to describe and illustrate Instruments, Apparatus, &c., which are either new or have not been previously described in this country.

† This section includes not only papers relating to Embryology properly so called, but also those dealing with Evolution, Development, Reproduction, and allied subjects.

‡ Archiv. Mikr. Anat., lxii. (1903) pp. 129–37 (1 pl.).

§ SB. Ges. Naturfreunde Berlin, 1902, pp. 33–6.

|| Biol. Untersuchungen, x. (1902) pp. 61–4 (1 pl.). See Zool. Zentralbl., x. (1903) p. 504.

**Structure and Development of Female Gonads of Lancelet.\***—The late Ludwig Neidert made a careful study of this, and the work has been completed by Adolf Leiber. An account is given of the early period of gonad-formation and of the period of ripening. The gonocœl or cavity enclosed by the gonadial wall, the "Nabel" from which the ovarian vessels arise, the "Narben" or cushions which surround the openings of the gonocœl, and so on are described in minute detail. The process of oogenesis is described. Particular attention has been paid to the blood-supply of the ovaries.

**Follicular Epithelium in Birds.†**—Marie Loyez finds that in some birds all the cells of the follicular epithelium exhibit, outside the nucleus, an almost spherical body of considerable size, composed apparently of coiled filaments. It stains strongly with iron-hæmatoxylin, and is analogous to the ergastoplasm of Garnier, the mitochondria of Benda, and the pseudochromes of Heidenhain. The differentiation is well seen in *Coccothraustes chloris*, *Emberiza citrinella*, *Fringilla caelebs*, and *Parus caruleus*, while in other cases, e.g. fowl and pigeon, it was not detected.

**Ovarian Ova and Follicles in Fishes.‡**—W. Wallace has studied the ovaries of various species of Teleostean and Elasmobranch fishes with particular reference to (1) the post-embryonic origin of ova and follicular epithelium, (2) yolk-nuclei and their significance, (3) egg-membranes and follicular epithelium, (4) the histology of egg-absorption, and (5) structural changes in ruptured follicles. The paper also includes a general description of the peculiar ovary of *Zoarces*, and some data bearing on the rate of growth and comparative fecundity of this fish.

**Influence of Central Nervous System on Development of Limbs in Amphibians.§**—P. Wintrebert has made some interesting experiments on Axolotl larvæ (*Stredon pisciformis*) and on the tadpoles of *Rana temporaria*. While R. Rubin has maintained that the influence of the nervous system is essential in the regeneration of parts of limbs in Urodela, A. Schaper found that the removal of the tadpole's brain did not hinder its general growth, and Wintrebert's results go towards confirming this. He cut the nerves to the hind limb of Axolotl larvæ just at the time when the toes were being formed, but after 6–12 days one or two toes appeared normally. More extensive experiments on the tadpoles of the frog gave the same result, and the author concludes that in these cases the nervous system is not necessary for the growth or differentiation of a limb.

**Development of Pineal Body in Amphibia.||**—J. Cameron finds that in *Rana*, *Bufo*, and *Triton* the epiphysis arises in the form of two primary outgrowths from the roof of the fore-brain, one on each side of the mesial plane; the right outgrowth disappears at an early stage

\* Zool. Jahrb., xviii. (1903) pp. 187–240 (5 pls. and 3 figs.).

† Comptes Rendus, cxxxvi. (1903) pp. 312–4.

‡ Quart. Journ. Micr. Sci., xlvii. (1903) pp. 161–213 (3 pls.).

§ Comptes Rendus, cxxxvii. (1903) pp. 131–2.

|| Anat. Anzeig., xxiii. (1903) pp. 394–5.

by blending with the stronger left. The occurrence of right and left primary epiphysial outgrowths has been noted by Beraneck in Lacertilia, by Dendy in *Hatteria*, by Hill and by Loey in Fishes, by Gaskell in Ammocœtes. Thus in the three lower Vertebrate classes the epiphysis arises as a bilateral structure, and not as a mesial structure. Therefore Cameron agrees with Dendy that "the ancestors of Vertebrates must have possessed a pair of parietal eyes which may have been serially homologous with the ordinary Vertebrate eyes."

**Development of Musculature and Skeleton in Spelerpes longicaudus.\***—H. S. Houghton gives an account of the origination and development of the adult muscles in this common Salamander, of the number and function of the transitory larval muscles, and of the relation between the two. He also discusses some of the developmental processes in the larval skull. The paper is mainly descriptive of the skeletal and muscular elements of a larva of 12 mm., with a few comparisons with *Rana* and *Cryptobranchus*.

**Circulation in Embryonic Stomach.†**—Ivar Broman has observed in human embryos of 5–16 mm. in length the occurrence of one, two, or several branches of the ductus venosus Arrantii penetrating the primordium of the omentum minus and forming a dense plexus in the mesodermic wall of the stomach. He has found similar veins in embryos of pig, cat, fowl, Chelonian, and *Necturus*. It seems probable that they occur in the embryos of all Vertebrates with a well-developed stomach. In adult Reptiles similar veins ("afferent portals") occur, and it is likely that the transient embryonic veins, which the author has discovered, correspond to these.

#### b. Histology.

**Amitotic Division in Vertebrata.‡**—A. Nemiloff has made a fresh study of this much discussed process. He found the most suitable cases for study to be amitotic division in the giant cells of the epithelium of the urinary bladder (of the mouse in particular), and in the lymphoid layer of the liver of Amphibians.

**Myoblasts.§**—A. Prenant discusses in the first place myoblasts in general, comparing their fibrillar differentiation with the kinoplastic filaments in other cells and in cell-division. He goes on to discuss the numerical increase of the fibrils by longitudinal splitting, and distinguishes complete and incomplete myoblasts according to the extent to which the fibrillar differentiation invades the cell. It is still a question whether the fibrils are formed independently in each myoblast, or whether they arise simultaneously in a series of cells forming a sort of syncytium. The distinction which the brothers Hertwig defined between epithelial and mesenchymatous myoblasts still holds good.

Prenant discusses in the second part of his communication the

\* Ohio Naturalist, iii. (1903) pp. 379-93 (4 pls.).

† Anat. Anzeig., xxiii. (1903) pp. 390-1.

‡ Tom. cit., pp. 353-68 (10 figs.).

§ Arch. Zool. Exper., 4th ser., i. (1903); Notes et Revue, No. 4, pp. lii.-lxiv. (12 figs.).

epithelio-muscular cells of Cœlentera, the epithelial myoblasts of higher Metazoa, and the epithelio-muscular cells of higher Metazoa.

**Structure of Nucleus in Smooth Muscle.\***—K. Münch had his attention arrested by an apparent transverse or oblique striation in the nucleus of smooth muscle-cells of cat, rabbit, guinea-pig, and other mammals. Careful investigation showed that the appearance was due to a spiral of chromatin making from  $3\frac{1}{2}$ –15 coils within the achromatin matrix. Münch regards this as the normal condition of the resting muscle-nucleus, but there is need for further observations on other objects.

**Cross-Striped Muscle.†**—K. Münch maintains that the so-called cross-stripping of muscle is the optical expression of the spiral arrangement of the anisotropic substance. To this theory of muscle-structure he appends a re-interpretation of the phenomena of contraction.

**Intracellular Threads in Nerve-Cells.‡**—E. Holmgren re-describes the so-called "intracellular threads" in the nerve-cells of *Lophius piscatorius*. His observations differ so much from those made by Solger on *Torpedo* that we are bound to suppose that the two sets of threads are quite different structures. The "threads" in *Lophius* are probably special differentiations of nerve-cells that form capsular processes. They are perhaps comparable to the filamentous differentiations of glia-cells. They do not represent, as in *Torpedo*, the hyaline crystalloid contents of the trophospongium-caliculi; they are not hyaline but composed of fine filaments; they have not a granular composition; they never lie in preformed canaliculi, but are always accompanied by capsular processes.

**Trophospongia in Glandular Cells.§**—E. Holmgren recalls his discovery of canalicular structure in liver-cells of the guinea-pig, which he regards as trophospongal canaliculi,—dense or loose networks of very fine tubules with parallel walls. He has found the same kind of trophospongal canals in the cells of Langerhans's islands in the pancreas of the white mouse. He vindicates his particular interpretation of the canaliculi against those suggested by others.

**Structure of Red Blood-Corpuscles.||**—Vladislav Růžička has studied the erythrocytes of frog, guinea-pig, and man. He points out that there are many gaps in our knowledge of the exact structure of the erythrocyte, of the membrane thereof, of the relation of the hæmoglobin to the cytoplasm, and as to the nucleus in mammalian erythrocytes. He has tried to fill up some of these gaps.

We can only notice his general conception that the red blood-corpuscle includes a vegetative part,—a reticular structure imbedded in a colourless matrix,—and a functional part, probably associated with a peripheral hæmoglobin envelope bound to a portion of the matrix.

**Axial Filament in the Adult Connective Tissue Fibril.¶**—P. A. Zachariades finds that the connective fibril, say in a tendon, is much

\* Arch. Mikr. Anat., lxii. (1903) pp. 41–54 (1 pl.).

† Tom. cit., pp. 55–107 (22 figs.).

‡ Anat. Anzeig., xxiii. (1903) pp. 37–49 (7 figs.).

§ Tom. cit., pp. 289–97 (8 figs.). || Tom. cit., pp. 298–314 (18 figs.).

¶ Comptes Rendus, cxxxvi. (1903) pp. 973–5.

more than a cylindrical filament without particular structure. It is a cellular prolongation with an external membrane, a peripheral collagen substance, and an axial filament.

**Origin of Giant Cells.\***—V. Babes calls attention to the frequent occurrence of budding in the proliferation of tissues, e.g. in the development and neoplastic changes of vessels. He finds that many giant cells are simply modifications or arrestments of vascular buds. This is well seen in tuberculous giant cells and in those of myxo-sarcomata.

**Transformation of Epithelium into Connective Tissue.†**—E. Retterer has made the experiment of separating the skin from the sub-jacent tissue (in the metatarsal region of the guinea-pig). The resulting irritation evokes hypertrophy and proliferation in the *epidermic* cells, which give rise to generations of cells that form reticulated and vascular connective tissue, becoming finally part of the papillary layer of the dermis.

**Intestinal Epithelium in Amphiuma.‡**—C. Saint-Hilaire describes the unusually large elements of cylindrical epithelium lining the gut of this Amphibian. Most noteworthy is his description of coiled filaments which occur in varied form in the plasma and appear to enter into close union with the nucleus. In each case there seems to be a single thread which starts near the periphery and coils inwards.

**Intracellular Canaliculi in Supra-renal Capsules.§**—C. Ciaccio has used Golgi's method with success in demonstrating endocellular canals in the suprarenal capsules. They are probably of service in conducting the products of secretion to the capillaries, as is probably the case in other glands of internal secretion.

**Cellular Nature of Zoochlorellæ.||**—J. Villard finds that the zoochlorellæ of *Hydra viridis*, *Paramecium bursaria*, and *Stentor polymorphus* have a cellular structure with a well-defined nucleus. Apart from the nucleus, the cellular nature of the zoochlorellæ is demonstrated by the presence of "*Metachromic corpuscles*," as in small unicellular algæ.

#### c. General.

**Deep-Sea Life in Indian Seas.¶**—A. Alcock gives an exceedingly interesting account of the voyages and exploration-methods of the Royal Indian Marine Survey ship "Investigator," and of the deep-sea fauna of the Indian region. "A walk across the bed of the ocean from Madras to the Andamans is idealised in a manner calculated to fascinate the reader and arouse the interest in marine research." The author has much to say in regard to adaptation to abyssal haunts, colour resemblance, habits of hermit-crabs, luminous fishes, commensalism, e.g. between the Scorpenoid fish *Minous inermis* and a compound Hydroid *Stylactis minoi*,

\* Comptes Rendus, cxxvi. (1903) pp. 314-6.

† Tom. cit., pp. 511-4.

‡ Anat. Anzeig., xxii. (1903) pp. 489-93 (6 figs.).

§ Tom. cit., pp. 493-7 (3 figs.).

|| Comptes Rendus, cxxvi. (1903) pp. 1283-4.

¶ 'A Naturalist in the Indian Seas,' Svo, London, pp. 24 and 318 (98 figs., tables, and a map). See Nature, lxvii. (1903) pp. 320-1 (2 figs.).

bird life, and so on. Among the more important discoveries emphasised in the book are those of a "solitary" coral (*Caryophyllia ambrosia*) the giant *Bathynomus*, and the blind lobster *Phoberus cæcus*.

**Arsenic in Animals.\***—Armand Gautier discusses the danger of inferring the presence of arsenic in animal tissues when the quantity is very minute, unless due allowance be made for the introduction of arsenic in the nitric acid or other reagents used in testing. He is satisfied that arsenic is normally present in mammals in the skin and its organs, in the brain, thyroid, thymus, &c., but not in the blood for instance. In the muscles of mammals there is but a slight trace. Gautier points out that the occurrence of arsenic in the skin of an ox is physiologically more interesting than its occurrence in a sponge or a holothurian or a fish, or in any animal living in sea water (which is distinctly arsenical), or feeding on algæ which are rich in arsenic.

**Index Animalium.†**—C. Davies Sherborn began in 1890 the gigantic task of making a complete list of all the generic and specific names that have been applied to animals since Linnæus inaugurated the binomial system (1758), of giving, as far as possible, an exact date for every quotation of a name, and of giving a reference to every name. In short, he set about making the zoological homologue of Jackson's 'Index Kewensis.' Mr. Sherborn is to be gratefully congratulated on the completion of the first part of this great dictionary, which contains the names given from the beginning of 1758 to the end of 1800.

**History of the Fauna of the Indo-Australian Archipelago.‡**—Max Weber sketches the following possible history. In pre-Tertiary times a connected land-mass, peopled by Eurasian animals, united Asia and Australia. In the Eocene Age this was broken up, forming in the south-east a unified region (Australia and New Guinea of to-day) and in the north a shallow coral sea with a complex of scattered islands. In the former there arose Monotremes, Marsupials, and Cassowaries, in the latter there arose a few primitive Rodents, Insectivores, and related types. In Miocene times the deep "Einsturzbecken" were formed, Celebes was upraised ("empfortancte"), and in the west a land-bridge above water-level was established with the Asiatic continent, so that a fresh entrance of Eurasian forms was opened to the east. Changes during the Pleistocene finally led to the present state of the Archipelago, which is zoo-geographically divisible into an Asiatic faunal region in the west, an Australian region in the east, and a transition area between.

**Chemical Physiology of Invertebrates.§**—Otto von Fürth has made a welcome contribution to comparative physiology in this volume. After some general chapters on organic compounds and their relation to metabolism, he discusses the blood and analogous fluids; the chemistry of digestion, respiration, and excretion; the animal poisons; the special

\* *Comptes Rendus*, cxxxvii. (1903) pp. 295-301.

† 'Index Animalium sive Index nominum quæ ab A.D. MDCCLVIII generibus et speciebus animalium imposita sunt. Sectio prima.' Cambridge (1902) 59 and 1195 pp.

‡ 'Der Indo-australische Archipel und die Geschichte seiner Tierwelt,' Svo, Jena, 46 pp., 1 map. See *Zool. Zentralbl.*, x. (1903) pp. 254-7.

§ 'Vergleichende Chemische Physiologie der niederen Tiere,' Svo, Jena, 1902, 14 and 670 pp.



secretions, such as mucin, silk, wax, &c.; the pigments; the skeletal tissues; the genital secretions, and so on. The author, who has himself made important contributions to comparative physiology, is to be congratulated on having done with scholarliness and judgment a piece of work which will be of great utility to students and investigators.

**Electrical Criterion of Vitality.\***—Augustus D. Waller reports the results of experiments conducted by aid of an electrical criterion—"blaze-reaction"—distinguishing between the living and not-living state. He refers first to the case of the hen's egg, which is particularly interesting, "for while we cannot tell *a priori* with any assurance whether or no a dormant egg will give the reaction characteristic of living matter, we may—after having learned by experience that it does *not* do so—expect to find the reaction make its appearance with the progress of development by incubation. And as a matter of fact, we find that this is what happens." The presence of a blaze-current is a certain sign that development has progressed within the egg.

Waller also finds that a crystalline lens is a good object upon which to study the nature of blaze-currents. Here again a blaze-current is a physical sign of the "living" state.

In another paper, A. Durig † describes observations which make it impossible, he says, to regard the appearance of blaze-currents as a specific property of living tissue. It is much more probable that they are to be considered as special manifestations of certain epithelial tissues. Nor can the presence of exclusively polarisation effects be taken as the sign of death in a tissue, since these may occur alone and typically in living organs.

**Relation between Weight of Liver and Total Surface.‡**—E. Maurel finds that in guinea-pig, rabbit, dog, fowl, &c., the weight of the liver bears (except in early stages) a constant ratio to the total surface of the body. The ratio is constant for the species, or for the variety of a heterogeneous species like the dog. The volume of the liver is affected by various factors, e.g. its antiseptic rôle, but especially by the nature of the food.

**Coloration of Myxinoids.§**—Bashford Dean notes that Myxinoids run the gamut of coloration common to deep-sea forms. Thus in a range of species they pass from black (*Myxine circifrons*) into dark purples, thence to violets and lavenders, then into "meaningless" greys, sometimes uniformly coloured, sometimes shaded (lighter ventrally, darker dorsally). In some cases lack of pigmentation in definite regions becomes a rather conspicuous feature, thus the tips of the barbels are generally white and the median lines may be unpigmented.

The author reports the occurrence of complete albinism (1 in 800) in *Homea burgeri*, of partial albinism in *H. stouti*, and of brilliant motley colouring in *H. polytrema*.

**Studies on Cyclostomes.||**—L. Plate contributes a first part of a series of studies of Cyclostomes, in which he describes twenty species of

\* Proc. Roy. Soc. London, lxxi. (1903) pp. 184-93, 194-211.

† Tom. cit., pp. 212-9.

‡ Comptes Rendus, cxxxvi. (1903) pp. 316-9.

§ Amer. Naturalist, xxxvii. (1903) pp. 295-8 (3 figs.).

|| Zool. Jahrb., ii. (1902) suppl. vol. v. pp. 651-74 (1 pl.).

*Geotria* and *Mordacia* from Australia and Chili. To these two genera, and to *Exomegas*, which the author has not been able to investigate, all the Petromyzonts of the Southern Hemisphere are referable. He describes four stages in the life-history of *Geotria chilensis* Gray, which correspond generally to those of the European lamprey. There is (1) a larval or ammocete stage, with two oral lobes, eyes hardly visible, and light colour; (2) a first stage of metamorphosis, with round suckorial mouth, without teeth, without tentacles, with eyes more distinct, and with light colour; (3) a second stage of metamorphosis, with round mouth, without teeth, with two tentacles, with cirri, with very large distinct eyes, with a reddish-brown dorsal streak and silver-white colour on the sides and below; (4) a juvenile stage (= *Macrophthalmus chilensis* Plate), with round mouth with teeth and two tentacles, with very large distinct eyes, with blackish-blue colour above and silver-white beneath.

**"Larynx" of Ganoids and Dipnoi.\***—R. Wiedersheim has investigated *Protopterus*, *Polypterus*, *Lepidosteus*, &c., in search of the foundations of the laryngeal skeleton and musculature. In *Protopterus* and *Polypterus* there is in the region of the glottis a muscular apparatus which widens and narrows the opening. He distinguishes in both a m. laryngeus dorsalis and a m. laryngeus ventralis, innervated by the vagus. In *Protopterus*, there is a considerable development of supporting cartilage. From his study he finds himself warranted in distinguishing a larynx dorsalis distinct from the larynx ventralis. Thus, if the syrinx of birds be included, there are in Vertebrates three distinct larynxes.

**Specific Differences in the Kidneys of Lepidogaster.†**—F. Guitel has studied five species of this little sucker-fish. In one species, *L. wildenowii*, there are mesonephric canaliculi composed of several distinct sections and provided with glomeruli. In *L. gouianii* and *L. bimaculatus* there are mesonephric canaliculi ("pelotonnés") without glomeruli. In two other species, namely, *L. candollii* and *L. microcephalus*, there are neither canaliculi nor glomeruli. Thus there is notable specific distinction even in the recesses of the kidney. This result is complicated by the fact that there are sexual differences, for the mesonephric "pelotons" are different in the sexes of *L. gouianii* and of *L. bimaculatus*. Furthermore, in one species at least, *L. bimaculatus*, there are seasonal differences associated with the periodic development of the gonads.

**Study of the Respiratory Exchanges in Water.‡**—J. P. Bounhiol and A. Foix point out some defects in prevalent modes of studying the respiratory exchanges in water. The essential thing, if normal conditions are to be sustained, is some way of restoring the oxygen to the water as it is used up and of removing the carbonic acid as it is produced. The authors describe a method whereby a known quantity of air circulates with automatic restitution of oxygen and removal of carbonic acid.

**Temperature of the Tunny.§**—P. Portier notes that the general belief that fishes have exactly the temperature of the medium in which

\* Anat. Anzeig., xxii. (1903) pp. 522-35 (9 figs.).

† Arch. Zool. Exper., ser. 4, vol. i. (1903). Notes et Revue, No. 6, pp. xcv.-c.

‡ Comptes Rendus, cxxxvi. (1903) pp. 1270-3 (1 fig.).

§ Bull. Soc. Zool. France, xxviii. (1903) pp. 79-81.

they live, is not quite warranted. P. Regnard made in 1891 precise thermo-electric experiments which showed that fresh-water fishes have to a fiftieth of a degree the same temperature as the water in which they live. But J. Davey found that some marine fishes are warmer than the surrounding water,—in *Pelamides* by  $7\cdot22^\circ$ , and in the Bonito by  $10^\circ$ .

Portier took the temperatures of numerous tunnies (*Thynnus alalunga*) just as they came out of the sea, and found that these powerful swimmers, which can keep up for hours with a vessel going at twelve knots, show (on deck) rectal temperatures of  $21\cdot5^\circ$ , temperatures at the level of the liver of  $19\cdot6^\circ$ – $24^\circ$ , and temperatures in the middle of the dorsal muscular mass of  $25\cdot5^\circ$ – $26\cdot7^\circ$ . The last was  $9\cdot2^\circ$  higher than that of the surrounding water.

**Unilateral Coloration with Bilateral Effect.\***—C. H. Eigenmann and Clarence Kennedy describe two specimens of a Leptocephalid, probably of the same species (*Leptocephalus diptychus*). Each has eight large black spots, one over the intestine somewhat in front of the anus, the others on the two sides of the body. Each spot was a single giant chromatophore, extending longitudinally over three or four somites. The peculiar fact was that the spots are unsymmetrical, those of one side alternating with those of the other, so that in the almost transparent animal there seemed to be seven spots at approximately equal distances. The authors regard this as a case of "mutual adaptation."

**Variations of Garter Snakes.†**—E. E. Brown has studied the variations of *Eutania* in the Pacific sub-region, from about latitude  $50^\circ$  in British Columbia to the neighbourhood of  $33^\circ$  in southern California. There is a great variety of soil and climate, especially as regards humidity: thus the rainfall at Puget Sound has reached 130 inches, while at Yuma, in south-eastern California, the average is little more than three. Under these circumstances, and having in mind the ease with which colour in reptiles is acted upon by external conditions, of which there is reason to believe that moisture is one of the most active, it is not surprising that colour variation should reach a maximum in a group of snakes which, through diversity of habit, occupy practically every station open to their kind. The author reduces 23 alleged species to three, two of which have three sub-species. He suggests (1) that humidity influences the metabolic processes which lead to pigmentation; (2) that the large amount of uric acid produced by reptiles should be considered in connection with coloration; and (3) that the liberty to indulge in striking colours may be associated with the protection afforded by the luxuriant vegetation and with the absence of the three snake-eating genera, *Spelotes*, *Ophibolus*, and *Elaps*.

**American Pelycosauria.‡**—E. C. Case has re-examined the American types and has been led to conclusions very different from those of Cope. All known reptiles from the American Permian, other than the Cotylosauria, possessed two temporal arches; there is no approach to a single temporal arch as described by Cope in some of them. The Pelycosauria followed a line of development that led to extinction, while the persist-

\* Science, xiii. pp. 828–30. See Zool. Zentralbl., x. (1903) pp. 504–5.

† Proc. Acad. Sci. Philadelphia, 1903, pp. 286–97.

‡ Amer. Naturalist, xxxvii. (1903) pp. 85–102 (10 figs.).

ent line of development was followed in other regions, perhaps in Africa. The progress of development in the skulls is traced, and five main changes are analysed. It is possible to recognise two phyla among the Permian Pelycosauria; one characterised by the persistence of the two Rhynchocephalian arches and the development of a weak articular region, culminating in the high-spined Pelycosauria, and the other characterised by the union of the arches and the development of a mammalian temporal region culminating in *Gomphognathus* and *Tritylodon*, perhaps in the Promammalia. The last branch practically includes all of the Theriodontia = Theriosuchia.

**How Birds make themselves understood by Man.\***—H. Gadeau de Kerville reports cases in regard to parrots, cockatoo (*Cacatua leadbeateri*), *Serinus hortulanus*, raven, *Buteo apivorus*, condor, dorking cock, *Euplocamus nyctemerus*, gulls and Anhinga, which illustrate various ways in which birds make or try to make themselves understood by man. The three modes employed are:—(1) by their natural language which includes various distinct words or cries; (2) by acquired language, mimetic of man's; and (3) by gestures of beak and wings, and so on.

**Bird and Man.†**—W. Schuster has an interesting article on the inter-relations between birds and men. He shows how cultivation, deforestation, planting, hunting, preservation, and so on have affected the avi-fauna. The timidity of some birds and the fearlessness of others in relation to man is discussed; and the generalisation is suggested that the rarer a species becomes the shyness of its members increases, since the feeling of safety associated with gregarious life is lost.

#### Tunicata.

**Arctic Variety of *Ciona intestinalis*.‡**—R. Hartmeyer notes that Arctic forms of this common Ascidian are marked by a superficial peculiarity:—the long cylindrical body narrows below the intestinal loop to form a stalk which extends for one-third to one-half of the length of the body and is terminally expanded into an attaching disc. All the specimens from high latitudes show this feature, which occurs as an occasional variation to a slight extent even in Mediterranean specimens. As there is no internal structural variation, Hartmeyer is content to regard the Arctic forms as local varieties:—*C. intestinalis* L. var. *longissima* Hartmr.

**New Molgulid.§**—G. C. Bourne describes a single specimen of *Oligotrema psammites* g. et sp. n., a sack-shaped Molgulid, covered with grains of sand like a Zoanthid, dredged by Willey from a depth of fifty fathoms off Lifu, New Britain. Although undoubtedly one of the Molgulidæ, it has many peculiar features. These are:—the wide separation of the branchial and atrial orifices; the great reduction in size of the atrial siphon and the concomitant suppression of the atrial lobes; the highly

\* Bull. Soc. Zool. France, xxviii. (1903) pp. 47-57.

† Journ. f. Ornithol., 1903, pp. 1-40.

‡ SB. Ges. Naturf. Berlin, 1902, pp. 203-5.

§ Quart. Journ. Micr. Sci., xlvii. (1903) pp. 233-72 (5 pls.).

differentiated pinnate muscular arms; the great reduction in the size and extent of the branchial sac; the suppression of the dorsal lamina and the feeble development of the endostyle and peribranchial grooves; the relatively great length and diameter of the œsophagus, and the presence of a large œsophageal groove extending nearly to the anterior end of the dorsal side of the branchial sac.

Dr. Bourne suggests that *Oligotrema psammites* is an Ascidian which captures and feeds on active Crustacea of large size relatively to itself, such as the Amphipod (*Platyscelus*?) found in the stomach. The name *Oligotrema* refers to the fact that the branchial sac is much reduced and confined to the anterior third of the body. The paper includes a useful discussion of the morphological value of the different layers of the Tunicate body, and a suggestion of the term "plerome" for the mesodermic tissue filling up the space between the gut and the external epithelium.

## INVERTEBRATA.

### Mollusca.

#### γ. Gastropoda.

**New Pteropod.\***—J. Meisenheimer describes *Schizobranchium polycotylum* g. et sp. n., a new gymnosomatous Pteropod from the Indian Ocean. In form it recalls *Clione*, but is at once distinguishable in having a well-developed dorsal glandular groove. The body is elongated, dilated in the middle, pointed at the hind end; the foot has a posterior median and two anterior lateral lobes; gills are represented solely by a small longitudinal skin-fold on the ventral surface of the hind end; the œsophagus has much branched "suctorial arms," radula-sac, and jaw-plate. The new form seems to be a highly specialised representative of the Pneumonodermatidæ.

**Breeding Experiments with Sinistral Snails.†**—K. Künkel has got specimens of *Helix pomatia* with left-handed shells to breed, but none of the (455) offspring were sinistral. When the development is made to occur under pressure, flat forms result, which acquire the normal shape when the pressure is removed.

The author has some interesting notes on the breeding habits and life-history. After awaking from the winter sleep snails take in much water, increasing their weight by 40-48 p.c. Copulation occurs in favourable conditions in April, especially during or after warm rain; the spiculum amoris is not essential to copulation; in spite of copulation some snails do not lay that summer, others may lay twice in the same summer. The egg-laying occurs from the middle of June to the middle of August, usually after a warm shower; with moderate warmth and moisture most of the eggs develop; the young are hatched on the 25th or 26th day after oviposition; they remain 8-10 days in the earth but leave it when the rain soaks in. Snails may remain lively till the end of November, if the conditions of warmth, moisture, and food are all favourable.

\* Zool. Anzeig., xxvi. (1903) pp. 410-2 (1 fig.).

† Tom. cit., pp. 656-64.

## Arthropoda.

## a. Insecta.

**Joints of the Walking Legs in Insects and Myriopods.\***—Carl Börner discusses the difficult question of the homologies of the various joints of the walking appendages in Myriopods and Insects,—the coxa, the trochantero-femur, the tibio-tarsus, and the prætarso—working from the simplest cases in larvæ of Thysanoptera on to the more specialised forms.

**Metamorphosis of Nervous System in Insects.†**—V. Bauer has studied representatives of seven orders, and finds that the central nervous system has by no means attained its definitive structure when the larva or young form is hatched. There is a new formation of ganglia (both sensory and motor centres) and of their protective tissue and tracheæ.

Until the beginning of the metamorphosis the ganglia show aggregates of neuroblasts which produce by unequal division a series of mother-ganglion-cells. These divide equally to form ganglion-cells. Finally the proliferating power of the neuroblasts ceases and they degenerate. The same process occurs in ametabolic insects, but more continuously.

The enveloping tissue of the imaginal ganglia is due to the immigration of connective-tissue cells from the cavity of the body. Tracheæ enter from particular points in the peritoneum where there is active proliferation. The connective tissue and tracheæ of the larval ganglia are absorbed by phagocytes, but these do not seem operative in the dissolution of the ganglion-cells.

**Insects and Petal-less Flowers.‡**—G. W. Bulman directs attention to Plateau's experiments§ on poppies (*Papaver orientale*) which were artificially deprived of their petals, the number of insects visiting the remaining parts being carefully noted and compared with the number of those visiting neighbouring intact flowers. Plateau contends that the insect-visitors are not attracted by the brilliant colours of the blossoms, but rather by the perception in some other way—probably by scent—that there is honey or pollen to be had. Great care was taken in the experiments to avoid touching any of the remaining parts of the flower with the fingers, for Plateau believes that insects have a keen sense of smell and dislike the scent of human fingers. On taking an average, it was found that each of 30 petal-less flowers received 4.5 visits, while each of 70 intact flowers received 2.4 visits. Bulman has seen bees visiting flowers of *Geranium phæum*, rockrose, bramble, and sage which had lost their petals.

**Insects and Flowers.||**—E. Ernest Lowe in referring to Plateau's experiments on poppies, &c., artificially deprived of their petals, argues

\* SB. Ges. Naturfr. Berlin, 1902, pp. 205–29 (2 pls.).

† Zool. Anzeig., xxvi. (1903) pp. 655–6 (2 figs.).

‡ Nature, lxxvii. (1903) p. 319.

§ Bull. Acad. Roy. Belgique, November 1902.

|| Nature, lxxvii. (1903) pp. 368–9.

that the removal of the coloured parts does not prove that colour has no influence in attracting insect visitors. "We are fond of attributing great intelligence and power of perception to the bee, and yet in this case the insect is not even given credit for being able to recognise what are known to it, from possibly long experience, as the essential parts of the flower! Because we buy well advertised goods, and still continue to buy them when their proved virtue renders advertisement a thing of the past, is it proof that the advertisement played no part in determining our choice?" After citing some of Lord Avebury's experiments, Mr. Lowe suggests that the correct method of settling the question would be to cut away, not the petals, but the stamens, &c. "Then if insects continued to visit flowers so mutilated we should have ground for thinking that petals exercise some attraction, or *vice versa*."

**Dimorphic Spermatozoa in Butterflies.\***—D. N. Voinov finds that in *Colias*, *Papilio*, *Macroglossa*, and *Vanessa* a twofold spermatogenesis is normal. From similar spermatogonia, there arise two sizes of spermatocytes, as in *Paludina* and *Pygæra* (Meves) and in *Scolopendra* (Bouin). The large spermatocytes show regular mitoses, the small spermatocytes divide somewhat irregularly. The result is bundles of large and of small spermatozoa, differing only in size.

What is the interpretation? Are the small spermatozoa non-reproductive, failures in short? Are the two kinds physiologically equivalent? Or does the dimorphism play a part in the determination of sex?

**Precocious Development of Pupal and Imaginal Organs in Caterpillars.†**—H. Kolbe describes a very interesting case of an abnormal caterpillar of *Dendrolimus pini* (= *Lasiocampa* or *Gastropacha pini*). The caterpillar had passed its third moult and had already attained to an approximation to the imaginal conditions as regards antennæ, maxillæ, and limbs. The formative discs of the subsequent wings were seen under the skin. The abnormal form represents a stage in the series of metamorphoses which no longer exists normally. Some more or less similar cases of precocity in development, in *Melanippe motanata* (E. H. Jones), in *Sericaria mori* (C. Majoli) and in *Tenebrio molitor* (Heymons) are referred to.

**Male Genital Appendages in Lepidoptera.‡**—E. Zander has made an elaborate study of these. He finds, from his investigations on *Paraponyx stratiotaria*, &c., that the male genital appendages in Lepidoptera arise from primordia morphologically the same as those in Hymenoptera and Trichoptera. The homology is manifested in four ways:—in the formation of a post-segmental insinking of the ventral region of the twelfth segment, forming the genital pouch; in the appearance of a pair of simple primitive papillæ at the base of this pouch; in the secondary splitting of each papilla into a lateral piece (valva) and a median piece (penis); and in the origin of the penis from originally paired components.

But the subsequent history of the genital pouch and the pair of

\* Arch. Zool. Exper., 4th ser., i. (1903); Notes et Revue, pp. xlix.–lii.

† S.B. Ges. Naturf. Berlin, 1902, pp. 158–66.

‡ Zeitschr. wiss. Zool., lxxiv. (1903) pp. 557–615 (1 pl. and 15 figs.).

papillæ is quite different in Lepidoptera and Trichoptera from that observed in Hymenoptera. In the latter, the two pairs of papillæ remain in close approximation at the base of the genital pouch which becomes deeper and deeper: in the former they obliterate the pouch so that the valvæ are displaced on to the surface of the body, while the penis becomes hidden in a new insinking, the penial pouch. In the Hymenoptera the conditions are much more primitive than in Lepidoptera and Trichoptera.

**Teeth of Diptera.**\*—W. H. Harris describes typical examples of the "teeth" borne on the flexible lobes of the proboscis of many Diptera. "The dental organs of Diptera may be divided into two groups, the compound and the simple. The former contain from two to four rows of teeth, developed on different lines; the simple contain organs more highly differentiated, and approaching in form the lower orders of vertebrate types. With the development of teeth there has throughout been a gradual diminution of pseudo-tracheæ, both in size and number, until they disappear entirely." So far as the author's researches have been carried, the dental organs of flies appear to supply a fairly constant additional set of specific characters.

**Diptera from Amber.**†—F. Meunier adds to a previous study of amber insects an account of *Silvius laticornis* (Tabanidæ), *Lophyrophorus flabellatus* g. et sp. n. (Xylophagidæ), *Paicohilarimorpha bifurcata* sp. n. (Leptidæ) *Hoclocera eocenica* sp. n. (Empidæ), and *Sphyracephala breviata* sp. n. (Diopsinæ).

**Mosquitos in Winter.**‡—Prof. Bruno Galli-Valero and Madame G. Rochaz give the results of their observations on the occurrence of the larvæ of *Anopheles* and *Culex* during winter in marshes in the Canton Waadt. The hibernating larvæ are found especially among the sedges and similar plants along the margin, but are rare in the open water. The ova are very resistant to cold and drought, and may survive the winter even if the marshy ground becomes dry.

**Anopheles in the Iberian Peninsula.**§—G. Pittaluga discusses the distribution of four species of *Anopheles* (*A. pseudopictus*, *A. superpictus*, *A. claviger*, and *A. bifurcatus*) in the Iberian peninsula, and their relation to the occurrence of malaria. The Iberian species are the same as those in Italy as reported by Ficalbi and Grassi, but the genus *Aedes*, which is not known in Italy, also occurs.

**Dipterous Parasite of the Vine-pest Haltica.**||—C. Vaney and A. Conte describe *Degeeria funebris* Mg., whose larva is parasitic in *Haltica ampelophaga* Guer., which is such a formidable enemy of the vines in southern districts. The importance of *Degeeria funebris* as a counteractive of *Haltica* is great, for it castrates and kills its host, and occurs in 35 per cent. of cases. Its development should be encouraged.

\* Journ. Quekett Micr. Club, 1903, pp. 389-98 (6 figs. and 1 pl.).

† Ann. Sci. Nat. Zool., xvi. (1902) pp. 395-406 (1 pl.).

‡ Centralbl. Bakt. Parasitenkunde, 1<sup>te</sup> Abt., xxxii. (1902) pp. 601-8.

§ Atti R. Accad. Lincei Roma (Rend.), xii. (1903) pp. 529-38.

|| Comptes Rendus, cxxxvi. (1903) pp. 1275-6.



**Male Organs of Scatophaga.\***—W. Wesché describes the male genitalia of *Scatophaga lutaria* and *S. stercoraria*, two common flies, related to our smaller house-fly, *Homalomyia canicularis*, but predaceous, with longer and more setose legs, stronger wings, and more highly developed teeth. The males are variable in size, some smaller, and others, contrary, to the general rule, larger than the females. In mating, the female is seized with a sudden spring (e.g. when killing prey or feeding), and forcibly held, though sometimes struggling fiercely. The male genital armature is suited for holding the female, and consists of no less than ten separate pieces with distinct functions. But, as Berlese has noted in regard to *Musca domestica*, the male, after seizing the female, is *passive*. It is the ovipositor that is forced into the cavity of the hypopygium, and its soft parts fit into and round the complicated armature of the male. The author describes the genital armature; notes that *S. merdaria* is, as Verrall stated, a mere variety of *S. stercoraria*; and points out that mutual sterility between nearly allied species is largely due to mechanical obstacles, as in the case of *S. lutaria* and *S. stercoraria*.

**Alimentary Tract of Silphidæ.†**—L. Bordas finds that this is remarkable in its length, its numerous internal plaits, the rudimentary nature of the gizzard, the minute structure of the hind-gut, the presence of a terminal ampulla somewhat analogous to the rectal vesicle of Dysticidæ, and the occurrence at the end of the gut of what seem to correspond with the rectal glands of Lepidoptera.

**Tracheal Gills on Legs of Larval Perlid.‡**—L. Lauterborn describes the structure and behaviour of the larva of *Teniopteryx nebulosa*, which bears tracheal gills on a situation not before observed, namely on the coxæ of the legs. Palmen has distinguished (1) pro-sternal and sternal tracheal gills on the first ventral thoracic sternite; (2) anal tracheal gills; (3) pleural tracheal gills on the sides of the thorax; and (4) lateral abdominal tracheal gills. A fifth set—coxal tracheal gills—must now be recognised.

**Formation of Chorion in Pyrrhocoris apterus.§**—A. Köhler confirms Korschelt's account of the formation of the chorion as a secretory process, not as one of cell-modification. Beaker-like openings were rightly interpreted by Leuckart as micropyles. The vitelline membrane is not present when the secretion of the first chorionic layer (endochorion) begins, it appears contemporaneously with the beginning of the internal lamellar layer of the exochorion.

**Systematic Position of Hemimerus.||**—K. W. Verhoeff discusses the opinion of some authorities that *Hemimerus* (living on rodents) is a sort of intermediate form between Blattodea and Dermaptera, but nearer the latter. He gives his reasons for concluding that *Hemimerus* is in no sense a transition-type, that it undoubtedly belongs to the Dermaptera,

\* Journ. Quekett Micr. Club, 1903, pp. 411-6 (1 pl.).

† Comptes Rendus, cxxxvii. (1903) pp. 344-6.

‡ Zool. Anzeig., xxvi. (1903) pp. 637-42 (2 figs.).

§ Tom. cit., pp. 633-6 (4 figs.).

|| SB. Ges. Naturf. Berlin, 1902, pp. 87-9.

but that it represents a very characteristic sub-order "Dermodermaptera" Verhoeff.

**Compound Eyes of *Machilis*.**\*—Frances Seaton has investigated the compound eyes of *Machilis variabilis*, which is found in great numbers on the under surface of stones which lie near the water's edge at the bottom of Fall Creek gorge, Ithaca, N.Y. A description is given of the corneal cuticle, the corneal hypodermis (two to each ommatidium), the four long cone-cells of each ommatidium, the distal pigment, the rhabdoms, which are quite distinct and separate from the cones, the retinulæ, and the nerves. Since there is in *Machilis* no shifting of the iris pigment and since the rhabdoms are of uniform width, the insect has, according to Exner, day eyes with apposed images.

#### β. Myriopoda.

**Variation in *Lithobius forficatus*.**†—S. R. Williams has studied at Cold Spring Harbor, Long Island, the variations of this cosmopolitan centipede. He took account of the number of prosternal teeth, the number of joints in the antennæ, the number of coxal glands, pits or pores which are found on the coxæ of the last four pairs of legs (twelfth to fifteenth). He found that length of body has essentially nothing to do with the number of antennal joints in specimens 15 mm. long or more; that length has very little to do with the number of prosternal teeth; that length has some bearing on the number of coxal pores in the adult; the correlation being closer on the thirteenth and fourteenth legs than on the twelfth or fifteenth legs; that the coxal pores show a greater segmental or serial correlation in the case of the thirteenth and fourteenth legs than bilateral symmetry; and that variations in this species point toward the normal condition in other species.

#### γ. Prototracheata.

**New Species of *Peripatus*.**‡—Richard Evans describes *Peripatus guianensis* sp. n. Out of nine specimens eight were females; six of these were larger than the male. The male had twenty-four pairs of appendages, one female twenty-seven, the others twenty-eight. The renal apertures of the fourth and fifth pair of legs are placed on top of a papilla situated between the third and fourth spinous pads. The papillæ situated near the mid-dorsal line are large, and stand on a base line which is almost rectangular. Principal papillæ alternate almost regularly with accessory papillæ. On the flanks the latter become broken up into several small ones, which occupy the spaces between the primary papillæ.

The female is possessed of receptacula seminis and ovarum. The ova are small, devoid of yolk, and endogenous. The embryos in the uteri are in successive stages of development. The male has an elongated common duct and on the twenty-second pair of legs has two pairs of sexual papillæ.

\* Amer. Nat., xxxvii. (1903) pp. 319-29 (9 figs.).

† Tom. cit., pp. 299-312 (10 figs. and 9 tables).

‡ Quart Journ. Micr. Sci., xlvii. (1903) pp. 145-60 (2 pls.).

The outer blade of the jaw has one accessory tooth ; the inner blade has also one, followed by a diastema and a row of 10 or 11 denticles.

#### δ. Arachnida.

**Copulation in Spiders.\***—Fr. Dahl found that out of sixty female spiders belonging to the genus *Latrodectus* eight bore broken-off male copulatory organs. The long ribbon-like "embolus" of the male *Latrodectus* 13-guttatus is inserted at the vulva, not directly into the receptaculum seminis, but into one of two spirally coiled tubes which lie beside it. Through these there is a curiously circuitous way to the receptacula, perhaps adapted to prevent hybrid-fertilisation. A broken-off embolus was found in at least three species of *Latrodectus*. A revision of the species is appended.

**Living Hydrachnid Larvæ in Trout's Stomach.†**—C. D. Soar calls attention to an interesting case. In the course of the investigations carried out by the "Lake Survey" under Sir John Murray, a trout was taken from Loch Rannoch, in the stomach of which Dr. T. N. Johnston found living larvæ of Hydrachnids. No similar case has been recorded. The larvæ seem to be very close to the larval forms of *Neumannia*, a sub-genus of *Atax*.

**New Species of Kænenia.‡**—Augusta Rucker describes *Kænenia* (*Prokænenia*) *wheeleri* from Texas. She places it beside Hansen's *Kænenia* (*Prokænenia*) *chilensis*, accepting Börner's suggestion that the sub-genus *Prokænenia* should include those species possessing lung-sacs, and that the sub-genus *Eukænenia* should include those species not possessing lung-sacs. A useful table is given of the habitats and diagnostic characters of the known species of this interesting genus.

#### ε. Crustacea.

**Colour-Physiology of Higher Crustacea.§**—F. Keeble and F. W. Gamble have investigated the structure and function of the chromatophores of certain Schizopod and Decapod crustaceans with especial reference to the effect of light on these organs and on these animals.

Under the influence of light the secretory activity of certain organs is modified ; an acid substance appears periodically in "liver" and muscle ; the appearance and disappearance of this acid substance coincides broadly with nocturnal and diurnal colour-change. In the progressive movements and orientation of the whole animal called forth by light, background is the most important factor, more important than and sometimes reversing the influence of change in light-intensity.

The response of the chromatophore pigments to light is twofold : direct and indirect, the latter through the mediation of the eye. The indirect response alone leads to an enduring redistribution of pigment.

The ultimate effect of monochromatic light on pigment-movements is the same as that of white light, but in both cases the background

\* SB. Ges. Naturf. Berlin, 1902, pp. 36-45 (3 figs.).

† Journ. Quekett Micr. Club, 1903, pp. 463-4 (4 figs.).

‡ Quart. Journ. Micr. Sci., xlvii. (1903) pp. 215-31 (1 pl.).

§ Proc. Roy. Soc. London, lxxi. (1902) pp. 69-71.

determines the nature and extent of the pigment movements. "Reaction to background" is traceable to the eye, and is probably a consequence of an asymmetrical distribution of retinal pigment brought about not by changes in the amount of light falling on the eye, so much as by changes in the way in which light falls on the eye.

The phenomena presented by the pigments are not exhaustively interpreted by any "protective" hypothesis. The chromatophores are centres of metabolic activity, and from them a nocturnal translocation of a blue substance takes place. There is evidence that this blue substance is produced from, and at the expense of the diurnal chromatophore-pigments. The blue substance passes from the chromatophore-centres, persists for a time in the body, and ultimately disappears.

The chromatophore-system of Mysidean Schizopods is built on a common plan—a primary system—to which colour-pattern is due. But Decapod Crustacea possess a primary and a secondary system of chromatophores. The primary system appears in the embryo, is completed in the *Mysis* stage, and persists throughout life, but takes no part in colour-pattern. The secondary system arises in an early stage in development, increases in extent throughout life, and produces the colour-patterns of the adolescent and adult. The chromatophores of the primary system are profusely branched, few in number, segmentally arranged and centralised; those of the secondary system are sparsely branched, numerous, irregularly arranged and decentralised.

The chromatophores of Mysidæ are multicellular organs. Those of the neural group are developed from the epidermis, but losing this connection acquire a close relation with the central nervous system. The distribution of the primary chromatophore-system follows that of the ganglionic parts of the nervous system. The chromatophores of Decapods are plurinuclear connected structures, and their distribution is not confined to the ganglionic parts of the nervous system.

The primary systems afford assistance in the determination of genera and species. They have taxonomic value both in early and late stages.

As to inheritance, the several adult colour-patterns of *Palæmon* and *Crangon* are constant and develop directly. The evidence tends to prove that both secondary and primary chromatophore-systems are inherited. The adult colour-pattern of *Hippolyte cranchii* is constant, but develops indirectly. The adolescent possesses a special colour-pattern, developed in large measure in relation with the primary system of the zoæa. Both persist though concealed by the independently developed adult pattern. In *Hippolyte varians*, several adult colour-patterns occur. They develop indirectly. The primary system is the same in all. The primary system is inherited; the adolescent colour-patterns are possibly inherited; but the inheritance is immaterial since the final goal is reached by any adolescent road; that is, the adult colour-pattern of *Hippolyte varians* is the result of environment.

**Statocysts in an Isopod.\***—A. Thienemann describes the first case of statocysts in an Isopod. He found two of these organs on the telson of *Anthura gracilis* which creeps about between the shells of *Balanus improvisus*. The organs are more primitive than those of *Mysis*; thus

\* Zool. Anzeig., xxvi. (1903) pp. 406-10 (2 figs.).

there is a narrow canal opening to the exterior, three long hairs reach the otolith but do not enter it (many penetrating it in *Mysis*), no nerve-endings have as yet been discovered. Extirpation of the organ did not result in any marked change in the movements of *Anthurus*, which is, however, very sensitive and lies inert when touched.

**Rare Thalassinid and its Larva.\***—Millet T. Thompson describes the external structure of the rare *Naushonia crangonoides*, of which only two specimens have been collected, and the zoëa and mysis-stages of the preadolescent development, which find their nearest counterpart in those of another aberrant Thalassinid *Calliaxis adriatica*. The author regards *Calliaxis* and *Naushonia* as aberrant forms, probably from pre-Axiid stock, which have retained characters that ally them on the one hand to the more primitive Axiidæ and on the other hand suggest relationship with genera of the Nephropsidæ. Their evolution has been along lines apart from that of most Thalassinids, especially in the development of the very unusual larval forms.

**Antarctic Amphipods.†**—Alfred O. Walker reports on the Amphipoda collected during the expedition of the 'Southern Cross' (1889-1900) to the Antarctic Seas. It is, he says, impossible not to be struck with the general resemblance of the collection, both as regards the number and size of individuals, and the great preponderance of Lyssiannassidæ, to such a collection as might be found in the Arctic Seas; and with the equally great difference in these respects from any collection that might be made under similar conditions of depth, &c. on our own or on tropical coasts. The collection included 22 species (15 new) in 17 genera, of which *Oradurea* is new.

**Intermediate Form between *Mysis oculata* and *Mysis relicta*.‡**—Eimar Lönnberg describes from brackish water in the southern part of the Bothnian basin specimens of a *Mysis* which appear to be in size and in details of antennæ, telson, and uropods intermediate between the marine *M. oculata* and the fresh-water *M. relicta*.

**Abyssal Lysiannassids.§**—E. Chevreux describes a number of new Amphipods of the family Lysiannassidæ collected by the 'Princess Alice' from the deep waters of the Atlantic and the Mediterranean. Six new species are described, one of which, *Paracallisoma alberti*, is very remarkable. Some of the captures were very interesting, e.g. of a *Cyclocaris* hitherto known only from Tahiti, but now found off the Cape Verde Islands, and of a species of *Hoplonyx* from the Mediterranean.

**Anuropus and Bathynomus.||**—H. J. Hansen has made a re-examination of the very remarkable abyssal Isopod *Anuropus branchiatus*, known only by the single specimen dredged off New Guinea by the 'Challenger.' He proposes to establish *Anuropus* Beddard as the type of a new subfamily, Anuropinæ, because the differences between its mouth-parts and those of the Cirolaninæ are so pronounced, that it

\* Proc. Boston Soc. Nat. Hist., xxxi. (1903) pp. 1-21 (3 pls.).

† Journ. Linn. Soc. (Zool.), xxix. (1903) pp. 38-64 (5 pls.).

‡ Zool. Anzeig., xxvi. (1903) pp. 577-81.

§ Bull. Soc. Zool. France, xxviii. (1903) pp. 81-97 (7 figs.).

|| Journ. Linn. Soc. (Zool.), xxix. (1903) pp. 12-25 (1 pl.).

may be considered a practical arrangement to remove *Anuropus* from the last-named subfamily, which will now be a much more uniform and more sharply defined group, unless indeed some form be discovered which will prove to be a transition between *Eurydice* and *Anuropus*. After such a discovery the subfamily Anuropinæ should be withdrawn. The author also contributes some additional and critical remarks to Bouvier's beautiful and exhaustive treatment of *Bathynomus giganteus*.

**Copepoda from Faroe Channel.\***—Thomas Scott discusses seven species of Copepods, each representing a separate genus, all belonging to the Harpacticidæ, which were obtained from a single piece of wood dredged from about 87 fathoms in the Faroe Channel. Three of the species, *Pseudotachidius similis*, *Laophante farøensis*, and *Cletoles armata*, are new; the others are all more or less widely distributed. The communication emphasises the desirability of carefully examining pieces of water-logged and partly decayed wood which may be brought up in the dredge or trawl-net. These pieces of wood not infrequently harbour rare, or even new, Entomostraca.

#### Annulata.

**Minute Structure of the Alimentary Canal of the Leech.†**—C. Spiess distinguishes three regions in the alimentary tract of *Hirudo medicinalis*,—(1) an anterior region including buccal cavity and pharynx, (2) a median or stomach region with the eleven paired pouches, and (3) a posterior or intestinal region. The walls are simple and but feebly differentiated. The stomach walls are reduced to two membranes comparable to the gastric mucous membrane in Vertebrates. The stomach-epithelium is glandular, with uniformly distributed secretory cells, like muciparous elements; but in no region are there differentiated glands in the strict sense.

The peripharyngeal glandular cells secrete, slowly but continuously, a product formed of refringent granulations, and with fermenting power (dissolving fibrin).

The pigmentary layer around the gut is formed of a large number of sinuous canaliculi, lined internally with large cells which are also seen in the blood-vessels. They are not hepatic, but they contain excretory granules analogous to those in the chloragogen cells of Oligochaets, and they eliminate indigo-carmin like the excretory cells on the caeca of *Aphrodite*.

**Distribution and Affinities of Sipunculids.‡**—Marcel A. Hérnbel begins by giving an account of the bathymetrical and horizontal distribution of *Sipunculus*, *Phascolosoma*, and *Phymosoma* on the Brittany coasts. He then discusses the distribution of Sipunculids throughout the world. The most differentiated species occur in warm regions, e.g. *Aspidosiphon gigas*, *Echinosiphon aspergillum*, and *Phascolion manceps*. The cosmopolitanism of Sipunculids is only apparent. They were probably northern in origin and have immigrated towards the equator.

\* Journ. Linn. Soc. (Zool.), xxix. (1903) pp. 1-11 (3 pls.).

† Revue Suisse Zool., xi. (1903) pp. 151-239 (3 pls.).

‡ Bull. Soc. Zool. France, xxviii. (1903) pp. 99-111 (2 figs.).

A scheme of the presumed affinities of the genera and species is submitted.

**Notes on Sipunculids.\***—Marcel A. Hérubel contributes the first part of a series of notes on the comparative morphology, comparative physiology, and "biostatics" of Sipunculids. The Priapulids are considered as the primitive types of Gephyreans from which the Echiurids and the Sipunculids have arisen, the former diverging towards the Annelida and the latter towards the Bryozoa. The structure of Sipunculids is discussed in relation to the mode of life, diet, habitat, &c., and an interesting contrast is drawn between *Sipunculus nudus* and *Phascolosoma vulgare*. This leads on to a somewhat difficult "biostatistical" discussion, in which the muscular differentiation in particular is mathematically expressed.

**Endothelial Derivatives and Pigment-Bodies in Gephyreans.†**—Marcel A. Hérubel discusses the peculiar spherules seen inside living blood-corpuscles of *Phascolosoma vulgare*. They increase in size, they move, they fuse, they pass into the cœlomic fluid. They seem to be peculiar kinds of pigment-granules, which become inert as they become large, and are finally eliminated.

The blood-corpuscles multiply by direct nuclear division (Cnénot), or by proliferation of certain regions of the endothelium. Hérubel discusses the amœboeytes and their rôle in accumulating pigment-masses in the connective tissue of the alimentary tract, whence elimination into the lumen of the gut is effected. The fixed ciliated "urns" of *Phascolosoma* and the free ciliated "urns" of Sipunculids are most important agents in digesting or agglutinating useless or foreign bodies in suspension in the cœlomic fluid.

**Gonads of Hesione sicula.‡**—W. Bergmann has been able to trace part of the history of the hermaphrodite reproductive organs in this Polychæt. They are not noticeable except at the climax of the sexual period. There seems to be protandry, the spermatozoa being formed first. After these disappear the eggs are liberated into the cœlom, but none were found fertilised. The gonads then degenerate and disappear.

**Development of Metameres in Salmacina dysteri.§**—A. Malaquin has studied the development of the sexually produced larva ("oozoite") of this Serpulid, and compares it with what he has previously observed in the asexually produced form ("schizozoite"). When the larva escapes from the maternal tube, where it passes through its trochosphere stage, it shows the outlines of the three regions of the adult worm:—(a) the cephalic region with a pair of eyes and strong cilia; (b) the thoracic region with three segments; and (c) a greatly reduced abdominal region. In front of the latter, which is practically only a pygidium, there is an undifferentiated zone, where future segments arise. The subsequent thoracic segments, 4th to *n*th, result from a transformation and incor-

\* Bull. Soc. Zool. France, xxviii. (1903) pp. 111-25 (2 figs.).

† Comptes Rendus, cxxxvi. (1903) pp. 971-3.

‡ Zool. Anzeig., xxvi. (1903) pp. 415-7.

§ Comptes Rendus, cxxxvi. (1903) pp. 389-91.

poration of segments arising in this pre-abdominal region. The metameres retain a certain plasticity and autonomy which admits of their being modified and adapted to new physiological or mechanical conditions in the course of development.

#### Nematohelminthes.

**Life-Span of *Filaria medinensis*.**\*—Sir Patrick Manson notes that opportunities for ascertaining with approximate accuracy the duration of the life-span of the guinea-worm are rare, and he therefore gives two cases which substantiate the general view that about a year must elapse between the infection from *Cyclops* and the emergence of the worm on the surface of the skin. The season of infection is correlated with the annual recurrence of certain conditions of moisture and temperature favourable to the *Cyclops* and to the development of its parasite.

**Unfertilised Ova of *Ascaris* in Human Fæces.**†—K. Miura and V. Nishincki describe the appearance of unfertilised ova of *Ascaris lumbricoides* in human fæces. When they occurred alone, apart from fertilised ova, only females were obtained from the patient. In the uterus of these females there were no spermatozoa, and the nuclei of the ova were in a resting stage. Attempts to hatch the unfertilised ova were futile; there was no segmentation. The appearance of the unfertilised ova is quite different from that of the familiar fertilised ova.

#### Platyhelminthes.

**Life-History and Reproduction of *Planaria maculata*.**‡—Winterton C. Curtis finds that apparently similar specimens of this Planarian collected from different localities show considerable differences in their life-histories. Some seem to have reproduced exclusively by fission, others only by the sexual mode, others by both at different seasons. It may be that the asexual mode replaces the sexual mode for a term of years.

The normal fission in *Planaria maculata* occurs without the previous appearance of any furrow at the place of division and without any previous development of the new organs necessary for two complete new individuals. It is as if a specimen were cut in two at a definite point behind the pharynx.

In the regeneration after normal fission there is no evidence that the new parts develop by the transformation of highly organised cells to a simpler type which produces the new organs. It seems rather as if the parenchyma included certain cells, distinguishable from the parenchyma proper, which are responsible for the new parts in regeneration and also for the sex-cells of the gonads.

The mature gonads are described for the first time, and their development is also traced. A note on the development of the animal makes

\* Brit. Med. Journ., No. 2218, July 4, 1903, p. 10.

† Centralbl. Bakt. Parasitenkunde, 1<sup>te</sup> Abt., xxxii. (1902) pp. 637-41 (2 figs.).

‡ Proc. Boston Soc. Nat. Hist., xxx. (1902) pp. 515-59 (11 pls.).



it plain that the adult pharynx does not originate at the place where the embryonic pharynx degenerates.

**New Monostome from Snapping Turtle.\***—W. G. MacCallum describes a peculiar Trematode from the lungs and larger bronchial tracts of the river snapping turtle (*Chelydra serpentina*). It seems necessary to establish a new genus in the family Monostomidae for this new form, for which the name *Heronimus chelydræ* is proposed. It stands far apart from the other genera in several respects, but especially in the position and nature of the genital opening, in the complicated structure and course of the uterine tract, in the unusual formation of the yolk-glands, in the presence of but one testicle, and in the position of the excretory pore.

**Behaviour of Chromatin in Segmentation of Ovum of Gyrodactylus.†**—C. v. Janicki finds that in the resting ovum the chromatin is distributed in fine granules in the nuclear area. As division begins the granules are somehow aggregated into about eight chromosomes which are enclosed in "karyomerites" or nucleoli, as Goldschmidt described in *Polystomum*. Subsequently the chromatin passes out from its provisional bearers leaving them empty plasmic nucleoli.

**Peculiar Cestode from Acanthias.‡**—Max Lühe describes the proglottis of *Urogonoporus armatus* g. et sp. n., from the spiral intestine of dog-fish. The anterior portion of the proglottis is modified into heart-shaped attaching lobes, forming a very mobile organ beset on each side with strong spines. The genitalia lie at the pointed posterior end. It seems that this new form represents a special family in the vicinity of the Tetraphyllidæ, but neither scolex nor chain was seen.

The group Cestodaria requires to be broken up, for *Caryophyllæus* and *Archigetes* are, as Mrázek has shown, in close relationship with the Bothriocephalidæ, while *Amphilitina* and *Gyrocotyle* remain, forming a characteristic group, or class, equivalent to Trematoda and Cestoda.

**Bothriocephalus in the Baltic Herring.§**—Guido Schneider found in the stomach and intestine of *Clupea harengus membras* numerous specimens, the young stage of *Bothriotenia proboscidea* Batsch (= *Bothriocephalus infundibuliformis* Rnd.). The well-developed scolex showed the closest resemblance to the characteristic head of the adult tapeworm, which is so common in Baltic salmon. As salmon devour herring the probability of their being thus infected with *Bothriotenia* is strong.

#### Incertæ Sedis.

**Evolution of Platystrophia.||**—E. R. Cumings has made a study of the morphogenesis of this Palæozoic Brachiopod, giving an outline of the probable history of the genus. Its highest degree of variability is

\* Centralbl. Bakt. Parasitenkunde, 1<sup>o</sup> Abt., xxxii. (1902) pp. 632-6 (2 figs.).

† Zool. Anzeig., xxvi. (1903) pp. 241-5 (4 figs.).

‡ Arch. Parasitol., v. (1902) pp. 209-50 (1 pl.); Centralbl. Bakt. Parasitenkunde, 1<sup>o</sup> Abt., xxxi. (1902) pp. 690-1.

§ SB. Ges. Naturf. Berlin, 1902, pp. 28-30.

|| Amer. Journ. Sci., xv. (1903) pp. 1-48, 121-36 (26 figs. and 1 pl.).

exhibited near the beginning (epacme) of its history, and there is a progressive restriction of variability to characters of lower and lower taxonomic value, till finally only characters of no physiological importance are affected. A corollary of this law of progressive restriction of variability is the rapid production of new types near the beginning (during the epacme) of a phylum. The notion that species are formed by the very gradual increment of selected variations certainly does not suit the case of *Platystrophia*. Given a new and vigorous stock in a favourable environment, the initiation of new species may take place with great rapidity. The history of the genus affords fine examples of morphological equivalence and homœomorphy. The greater part of the history of *Platystrophia* is progressive, but a few genuinely retrogressive forms occur, which are interpretable as due to the acceleration of gerontic changes. The general law is well illustrated, that the older a character, the more persistent it is.

#### Echinoderma.

**Regeneration of the Body of a Starfish.\***—Sarah P. Monks cut arms of *Platystrophia* (*Linckia*) *fascialis* at different distances from the disc, and a number of single rays produced new bodies. The free ray made a new body and the rest of the starfish produced a new ray, and there was very little difference in the rate of growth of each, and no definite place for breaking. The manner of growth is as follows:—The cut edges heal and draw down towards the oral side, then small knobs appear at the end which grow into rays in which the ambulacral furrow soon appears, with the small mouth in the centre of the rays.

#### Cœlentera.

**Excretory Cells in Hydroids.†**—A. Billard describes granular amœboid ectodermic cells in various calyptoblastic hydroids (*Campanularia*, *Obelia*, *Plumularia*, &c.), which do not form perisarc (as Jickeli supposed) and do not contain reserves, but are apparently receptacles for waste-products. The "excretory cells" are especially abundant at the extremities where growth is rapid, and in old colonies or parts. The granules are not eliminated.

**Some New and Rare Corals from Funafuti.‡**—G. C. Bourne gives a figure of *Lophohelia tenuis* Moseley, once previously recorded from a 'Challenger' dredge in the Philippines. He describes and figures *Trochocyathus vasiformis* sp. n. and *T. hastatus* sp. n., and indicates how they differ from members of Moseley's genus *Odontocyathus*.

**Species of Corallium.§**—Kamakichi Kishinouye finds that the species of *Corallium* are more numerous than has hitherto been supposed. He describes five new species,—*C. japonicum*, *C. boshuensis*, *C. sulcatum*, *C. konojoi*, and *C. inutile*.

\* Proc. Acad. Sci. Philadelphia, 1903, p. 351 (1 fig.).

† Comptes Rendus, cxxxvii. (1903) pp. 340-2.

‡ Journ. Linn. Soc. (Zool.), xxix. (1903) pp. 26-37 (2 pls.).

§ Zool. Anzeig., xxvi. (1903) pp. 623-6.

**North American Scyphomedusæ.\***—C. W. Hargitt contributes a useful synopsis of the Stauromedusæ (3 genera), Peromedusæ (1 genus), Cubomedusæ (1 genus), and Discomedusæ (12 genera) of North American waters.

**Prophysema hæckelii.†**—N. Leon describes this Gastræad, which resembles *Haliphysema tumanowiczii* described by Bowerbank as a sponge, and referred by Hæckel to the Gastræadæ under the title *Prophysema*. Leon's form, obtained from the island of Radoe, north of Bergen, is a club-shaped body, 2 mm. in length by  $\frac{1}{2}$  mm. in thickness; the oral surface is free with a circular opening; the aboral end is fixed by a short, solid stalk, whose base is a plano-convex disc; the wall of the body is thick and without pores; the ectoderm is a synectium with various kinds of sponge-spicules and sand-grains fixed on to it; the endoderm shows flagellate cells. The author scouts the idea that Hæckel could have called a Foraminifera Gastræad, as Delage and others have suggested. That *Prophysema hæckelii* sp. n. is not a Foraminifera is certain.

#### Porifera.

**Carterius Stepanowi Dyb.‡**—O. Zacharias notes that this fresh-water sponge of Bohemia, Galicia, Hungary, and Russia, has been reported from Mehlingen in the Rheinpfalz by R. Lauterborn, and that it seems also to occur in the Schöhsee at Plön. Not that Zacharias found the sponge, but he got in the bottom mud numerous flesh-spicules exactly corresponding to those figured by Lauterborn. Zacharias also calls attention to the fact that while all other fresh-water sponges have species of *Zoochlorella* as symbions, *Carterius stepanowi* Dyb. is said by Lauterborn to contain *Scenedesmus quadricauda*, one of the Palmellaceæ.

#### Protozoa.

**Influence of Light on Amœbæ and their Cysts.§**—Georges Dreyer has experimented with light passing through rock-crystal, through uncoloured glass, and through blue glass. The results show that the cysts are much more resistant to the destructive influence of the rays of light than the unencysted amœbæ are, 30–33 times more in the case of the rock-crystal, 5·5–6 times more in the case of uncoloured glass, five times more in the case of blue glass. Cysts are destroyed in about 25 minutes by light passing through rock-crystal, in 60–70 minutes when the same quantity passes through uncoloured glass, and in 70–80 minutes in the case of blue glass. Light passing through rock-crystal (ultra-violet rays) kills the amœbæ 13–14 times quicker than when it passes through uncoloured glass, and 18–20 times quicker than when it passes through blue glass; but in the case of the cysts the fatal effect is reached 2·5–3 times more quickly with rock-crystal than with uncoloured glass, and three times more quickly than with blue glass.

\* Amer. Nat., xxxvii. (1903) pp. 331–45 (6 figs.).

† Zool. Anzeig., xxvi. (1903) pp. 418–9.

‡ Biol. Centralbl., xxiii. (1903) pp. 483–4.

§ Oversigt k. Danske Videnskab. Selskabs Forhandl., 1903, No. 3, pp. 399–421 (2 pls.).

**Myonemes of Protozoa.\***—A. Prenant in attempting a phylogenetic survey of the evolution of muscular elements has begun naturally with the so-called myonemes of Protozoa. He brings together in an interesting way the longitudinal fibrils or striations of *Stentor*, *Bursaria*, *Prorodon*, &c.; the usually transverse myonemes of Gregarines, longitudinal in *Clepsidrina blattarum*, *Selenidium*, and *Platycestis*; the combination of longitudinal and circular fibrils in various Flagellates, and so on.

**Multicilia lacustris Lauterborn.†**—E. Penard has made some observations on this interesting form—a spherical or sub-spherical, Heliozoon-like, multinucleate Flagellate. The 2–7 nuclei lie close together in a clear central endoplasm; the general plasma contains numerous gametes of *Pandorina morum* which are captured in a very characteristic way.

Penard finds a delicate peripheral layer or “periplast” (Wassiliowsky and Senn) composed of specially differentiated plasma. He discusses in detail the little round grain or “blepharoplast” at the base of each flagellum. Is it a kinetic centre, a centrosome, or a point of insertion? The author cannot at present accept or reject any of the three possible interpretations.

**Observations on *Monas vulgaris*.‡**—P. A. Dangeard finds that in this species, readily obtained from infusions of hay, the fission is longitudinal and accompanied by a rapid growth in the anterior region, and that the nucleus divides indirectly by a teleomitosis comparable to that in Chlamydomonads. The blepharoplast and the “*rhizoplast*” are very clear in this species, and the former may be compared to a centrosome since it remains included in the ectoplasm during the teleomitosis.

**Parasite of Texas Fever.§**—V. Babes has been forced to recall attention to the fact that in 1888 he discovered and described the peculiar parasite—midway between Bacteria and Protozoa—which causes the hæmoglobinuria of cattle known as Texas Fever, Tristeza, &c., and the “Carceag” of sheep.

**Myxosporidian Parasite of *Geophilus*.||**—Howard Crawley describes *Nosema geophili* from the intestine of *Geophilus*. The irregular form and multinucleate condition of this new Sporozoon indicate a position among the Myxosporidia. Its occurrence as a free form in an Arthropod seems to warrant placing it, at least provisionally, in the genus *Nosema*. The observation is interesting in view of the fact that this is the first recorded case of a myxosporidian being found in a myriapod. While *Geophilus* is parasitised by a Gregarine (*Rhopalonia geophili*), by a Coccidian (unidentified), and by this new myxosporidian, infection is only occasional. The comparative immunity is doubtless due to the solitary habit of this centipede.

\* Arch. Zool. Exper., 4th ser., i. (1903) Notes et Revue, No. 6, pp. c.–civ. (2 figs.).

† Revue Suisse Zool., xi. (1903) pp. 123–49 (1 pl.).

‡ Comptes Rendus, cxxxvi. (1903) pp. 319–21.

§ Centralbl. Bakt. Parasitenkunde, 1<sup>o</sup> Abt., xxxiii. (1902) pp. 449–58 (4 figs.).

|| Proc. Acad. Sci. Philadelphia, 1903, pp. 337–8 (4 figs.).

**Plasmodium præcox**.\*—P. Argutinsky has been able to study in particular the pitting (*Tüpfelung*) of the margin of the erythrocytes bearing the "half-moon" stages of the *Tropica* and *Tertiana* parasites.

**Parasite of a Central South American Horse Disease**.†—O. Voges has found that a distinct form of *Trypanosoma* (*T. equina* sp. n.) is the cause of Mal de Caderas, a serious fever-disease associated with hæmoglobinuria, hæmaturia, rapid and great oscillations of temperature, and so on. It only occurs in swampy regions and may be kept from spreading by shifting to a dry quarter. It may be spread by inoculation, but is not contagious. The agent in its dissemination is some suctorial insect, but whether the agent is *Tabanus* or *Musca brava* or a mosquito is uncertain.

**Trypanosomiasis of Horses in the Philippines**.‡—W. E. Musgrave and N. E. Williamson submit a preliminary report on this disease. They discuss (1) the history of the epidemic in the Philippine Islands, involving a direct loss of not less than two million dollars in 1901 and 1902; (2) the mode of transmission and infection,—trypanosomiasis is a wound-disease, the infectious organism being brought into contact with a wounded surface by insects, with this further complication that "Manila rats" are also infected with the *Trypanosoma* of the horse disease; (3) the symptoms and diagnosis; and (4) the preventive measures through proper quarantining and by enforcement of efficient sanitary regulations.

**Development of Gregarines**.§—L. Leger and O. Dubosq contribute some notes on the life-history of *Stylorhynchidæ* and *Stenophoridæ*, as represented by *Stylorhynchus longicollis* F. St., and *Stenophora brölemanni*.

\* Centralbl. Bakt. Parasitenkunde, 1<sup>o</sup> Abt., xxxiv. (1903) pp. 144-9 (1 pl.).†

† Zeitschr. Hyg. und Infektionskrankheiten, xxxix. p. 323. See Centralbl. Bakt. Parasitenkunde, 1<sup>o</sup> Abt., xxxi. (1902) pp. 755-8.

‡ Publications of Department of the Interior Bureau of Government Laboratories, Manila, 1903, No. 3, 26 pp. (2 pls.).

§ Arch. Zool. Exper., 4th ser. vol. i. Notes et Revue, No. 6, pp. lxxxix.-xcv. (2 figs.).



## BOTANY.

## GENERAL,

Including the Anatomy and Physiology of Seed Plants.

## Cytology,

including Cell-Contents.

**Mitosis in *Synchytrium*.**\*—F. L. and A. C. Stevens have studied the behaviour, during division, of the primary nucleus of *S. decipiens* which invades single cells of the hog peanut. The nucleus attains to a very large size, having a diameter of  $35 \mu$  with a nucleolus over  $11 \mu$  across. The nuclear wall is very distinct and the chromatin is collected on the wall and around the nucleolus. The first sign of division is the vacuolisation of the nucleolus, then the membrane loses its sharpness, becomes gelatinous and finally disappears, though the outline of the nucleus is not lost. A spirem condition of the chromatin is meanwhile produced by the globules of the coarse and lumpy chromatin becoming elongated and forming threads which are crossed and tangled in inextricable confusion. During these stages the nucleolus disappears and the nucleus becomes much shrunken, being often reduced to half its diameter. The threads of the spirem group then gradually form a small spindle which lies in the middle of the nuclear area but does not extend to its periphery; the spindle shows no centrosomes or radiations. On the spindle only a few short chromosomes are found so that a great condensation or an actual reduction of the chromatin must take place. The chromosomes are apparently four in number and after their polar migration the spindle lengthens, as in *Albugo Bliti*, and the telophase is similar to that described for that form.

**Mitosis in *Pellia*.**†—C. J. Chamberlain in his investigation deals with the first two nuclear divisions in the germinating spore. For comparison, however, mitosis was studied in other phases of the life-history. The principal conclusions are as follows. The stimulus to nuclear division comes from within the nucleus. The asters are of cytoplasmic origin. The caps come from the outer portion of nuclear membrane or from a *Hautschicht* surrounding the nucleus. The appearance and disappearance of the astral rays suggest that they are concerned in the movement of nuclear matter. The centrosphere is formed by the astral rays, not the rays by the centrosphere. The centrosphere of *Pellia* represents a condition intermediate between the well-defined centrosphere of some of the thallophytes and the centrosomeless condition of the higher plants. The spindle-fibres, except the mantle-fibres, grow from one pole to the other. In early stages two half-spindles are often distinguishable.

\* Bot. Gazette, xxxv. (1903) pp. 405-14 (2 pls.).

† Reprint from the University of Chicago Decennial Publications, series 1, x. (1903) 18 pp., 4to. The University of Chicago Press, Chicago, Illinois. Also Bot. Gazette, xxxvi. (1903) pp. 28-51 (3 pls.).

## Structure and Development.

## Vegetative.

**Seedling of *Torreya Myristica*.**\*—Edith Chick describes the morphology and internal structure of the members in seedlings of from 16–19 months, of this gymnospermous plant. The author lays stress on the retention of certain primitive characters. The lobing and adhesion of the hypogeal cotyledons recalls the state of affairs in the two primitive genera *Zamia* and *Ginkgo*, and the presence of centripetal wood in the cotyledon is of interest from this point of view; the transfusion tissue has the appearance of being formed from the parenchyma outside the bundle rather than as originating as a direct extension of the centripetal xylem. The method of transition from root-structure to that of the hypocotyl and the petioles of the cotyledons is somewhat exceptional.

**Pathological Plant-Anatomy.**†—E. Küster describes in considerable detail the anatomy of diseased or abnormally developed parts of plants. The subject matter is considered under the following headings. I. *Restitution*, where changes in growth, induced by sections and wounds, lead to the new formation of the cut-off parts, or to proliferations of various kinds. II. *Hypoplasie*, or arrested development due to various inhibiting causes. III. *Metaplasie*, or progressive changes due to overstimulations which lead to structural changes in excess of the normal. IV. *Hypertrophie*, where the cells attain inordinate dimensions due to excessive growth while young and turgid, e.g. most galls. V. *Hyperplasie*, including those abnormalities which arise from an inordinate increase in the average number of cells. In a concluding chapter the author gives a general account of the pathological processes themselves.

**New Secretory Apparatus in Conifers.**‡—G. Chauveaud has discovered in members of the Coniferae true laticiferous elements of two kinds: the one formed of a series of more or less elongated elements arranged end to end, the other of single elements of indefinite length but unbranched. Both kinds may occur in the same species, e.g. in the cedar. They show considerable differences in different plants, so that it is necessary to describe them specially in each species. Speaking generally, the wall is thin and not distinguished by any character from the wall of neighbouring parenchymatous cells. The contents are without colour or slightly coloured, granular, with suspended drops, forming an emulsion. They are found in different parts of the plants but especially in the pith of the root, while in the stem and leaf they are most abundant under the epidermis. They appear very early, being well developed in the embryo; they are especially noticeable in young plants. Their number, which is generally very large, is variable, but their distribution in different parts of the plant body is constant for a

\* New Phytologist, ii. (1903) pp. 83–91 (2 pls.).

† 'Pathologische Pflanzenanatomie,' by Dr. Ernst Küster, 300 pp. of text, 121 figs., Jena (Fischer), 1903. See also Nature, lxxviii. (1903) pp. 244–5.

‡ Comptes Rendus, cxxxvi. (1903) pp. 1093–4.

given species, and affords distinctive specific characters. The laticiferous elements occur in the different tribes of the family.

KÜSTER, E. — *Beobachtungen über Regenerationserscheinungen an Pflanzen.* (Observations on regeneration in plants.)

*Beih. z. Bot. Centralbl. Orig. Arbeit*, XIV. (1903) pp. 316–26 (6 figs. in text).

#### Reproductive.

*Lagenostoma Lomaxi*, the Seed of *Lyginodendron*.\*—F. W. Oliver and D. H. Scott give an account of the structure of this seed which occurs in calcareous nodules of the lower Coal-measures. It approaches the Gymnosperm type in that the integument and nucellus are distinct in the apical region only, the body of the seed which contains the large single macrospore with traces of prothallial tissue, showing complete fusion of integumental and nucellar tissues. The seed is remarkable in having a large nucellar pollen-chamber, around which the free part of the integument forms a complicated envelope composed of radiating chambers, usually nine in number. A single vascular bundle enters at the chalaza, and branches below the macrospore into nine radially running bundles, each of which passes to the apex of the seed. When young, and sometimes also at maturity, the seed is enclosed in a cupule, extending in young specimens, above the micropyle. The pedicel and cupule bear numerous capitate glands which closely agree with the glands on the vegetative organs of *Lyginodendron Oldhamium*. The structure of the vascular bundle in the pedicel strengthens the conclusion that the seed belongs to *Lyginodendron*. The evidence thus indicates that in a transitional type, such as *L. Oldhamium*, with leaves wholly fern-like in structure and form, but with decided Cycadean as well as Filicenean characters in the anatomy of stem and root, the seed habit had been as fully attained as in any known palæozoic Gymnosperm. Probably many other of the plants grouped under Cycadofilices also possessed seeds.

**Development and Structure of the Seed-Coat in Gentianaceæ.**†—J. Guerin gives the results of his investigation of 30 genera, including 204 species of this order. With the exception of the saprophytic *Voyria* and of *Obolaria virginica*, the ovules of which are naked, the ovule of Gentianaceæ has always a single integument. The number of layers which this comprises is very variable; in the Menyanthoideæ it reaches 16 to 20, while in the Gentianoideæ there are fewer, 10, 8, 6, or in some species of *Gentiana* only 2 or 3. In the Gentianoideæ the innermost layer shows no peculiarity, in the other tribe it is early characterised by the radial division and elongation of its cells. In the Gentianoideæ there is no vascular bundle in the integument, in the Menyanthoideæ the vascular bundle is well developed. The embryo-sac which by absorption of the nucellus is in contact with the integument, is generally very small, but in some Gentians it becomes very large, and the antipodal cells are well developed and often numerous.

The course of development of the seed-coat is different in the two tribes.

\* *Proc. Roy. Soc.*, lxxi. (1903) pp. 477–81.

† *Comptes Rendus*, cxxxvi. (1903) pp. 1094–7.



In the Gentianoideæ the ovular integument becomes gradually absorbed from within, the external layer alone persisting to form the testa; in some Gentians the antipodal cells have a digestive function. In the Menyanthoideæ absorption takes place at first outwards from the most internal layer (tapis) which seems to exercise a digestive part on its neighbours, itself remaining intact till an advanced stage of development is reached. The absorption of the integument is less complete than in the other tribe; in *Menyanthes foliolata* the testa comprises fifteen layers of hard pitted cells. The single layer which forms the seed-coat in the Gentianoideæ shows numerous structural modifications.

The author's researches confirm the previous opinion, based on morphological and biological characters, and on the anatomy of the vegetative organs, that the Gentianaceæ fall into two well-marked subfamilies Gentianoideæ and Menyanthoideæ.

**Abnormal Flowers of *Helenium autumnale*.**\* — W. C. Worsdell gives the results of his examination of a number of abnormal heads of this autumn-flowering composite, and discusses the morphological bearing of the facts elicited. The abnormalities were due to a leaf-like development (virescence) of the various floral members associated with a proliferation of the axes. Pappus, corolla, stamens, and carpels were all replaced in various degrees by green leafy structures. The cause of the abnormal growth was presumably due to the stimulation of a tiny *Phytoptus* which was found in the aberrant flower-heads. The author insists on the importance of such sports as aids in the solution of problems in morphology.

FAUTH, A.—Beiträge z. Anatomie u. Biologie der Früchte u. Samen einiger einheimischer Wasser- und Sumpfpflanzen. (Anatomy and biology of fruits and seeds of some endemic water and marsh plants.)

Beih. z. Bot. Centralbl. Orig. Arbeit, XIV. (1903) pp. 327-73 (3 pls.).

### Physiology.

#### Nutrition and Growth.

**Nitrogenous Metabolism in Minute Algæ.**† — Harriette Chick describes a new species of *Chlorella*, a unicellular green alga, *C. pyrenoidosa*, which differs from *C. vulgaris* in having a conspicuous pyrenoid. It occurs in sewage, and was also found to have grown in dilute ammoniacal solutions. The author has studied its nitrogenous metabolism in a series of cultures and finds that it prefers to have its nitrogen presented to it in the form of ammonia or ammoniacal compounds; among the latter, urea, uric acid, &c., rank high in nutritive value. It appears also that the ammonia after being absorbed is elaborated into albuminoid ammonia. The presence of glucose in a culture liquid causes a definite change in the chlorophyll-body and a general stimulation of growth. A similar effect has been noted by other observers in three other simple green algæ, including a species of *Chlorella*.

P. G. Charpentier ‡ has studied the method of assimilation of

\* Journ. Roy. Hort. Soc., xxvii. (1903) pp. 943-55, 10 figs. in text.

† Proc. Roy. Soc., lxxi. (1903) pp. 458-76 (1 pl.).

‡ Ann. Inst. Pasteur, xvii. (1903) pp. 321-34.

nitrogen in *Cystococcus humicola*, and concludes that the alga does not use the nitrogen of the atmosphere. It readily assimilates nitrates both in light and darkness, and probably acts by reducing them in part to an ammoniacal condition. It makes use with equal facility of ammoniacal nitrogen probably by means of a partial oxidation; light is not an indispensable condition. It can use the nitrogen present in organic compounds, such, for instance, as asparagin and peptone.

**Nutrition of Plants deprived of their Cotyledons.\***—G. André obtains the following results by depriving seedlings (of Haricot d'Espagne) of their cotyledons at a very early stage. The removal is followed by a complete check to vegetation; no increase in dry weight was observed in the two days following the operation. In the fortnight following the removal the dry weight of 100 plants increased by 51.5 g. of which 8.6 g. represented mineral matter. In the same period control plants with cotyledons showed increases of 129 g. and 19 g. respectively.

The author finds a remarkable parallelism between the relative absorption of nitrogen and of phosphoric acid in the two sets of seedlings.

In a later communication † the author describes the variation in the amount of potash and organic matters in a similar series of experiments.

**KLEBS, G.—Willkürliche Entwicklungsänderungen bei Pflanzen. Ein Beitrag zur Physiologie der Entwicklung.** (Arbitrary changes in plant development. A contribution to the physiology of development.)

Svo, iv. and 166 pp., Jena (Fischer) 1903.

#### Irritability.

**Resistance of Seeds to High Temperatures.‡**—H. H. Dixon describes the results of experiments on the maximum temperatures seeds can withstand without losing their germinative power. The seeds were dried and then exposed for at least one hour to the higher temperature. Afterwards they were sown on moist sand. The highest temperatures recorded, after exposure to which germination was possible, were 121° C. with *Medicago sativa*, 120° with *Convolvulus tricolor*, 118° with *Avena sativa* and *Hordeum distichum*. The time needed for germination is increased by exposure to temperatures near the maximum. Long exposure to a comparatively low temperature may prove more fatal than a short exposure to a high temperature.

**FILIPPI, DOMENICO.—L'azione degli anestetici sulla traspirazione dei vegetali.** (Action of anaesthetics on transpiration.)

*Atti d. Soc. Tosc. Sci. Nat. (Pisa) Memor.*, XIX. (1903) pp. 91-105 (2 pls.).

#### Chemical Changes.

**Nature of Protoplasm and Enzymes.§**—Th. Bokorny records the results of his research on the action of various reagents on living cells. He noted the action of alcohol of different percentages on yeasts and

\* *Comptes Rendus*, cxxxvi. (1903) pp. 1401-4.

† *Tom. cit.*, pp. 1571-3.

‡ *Rep. Brit. Assoc.*, 1902, p. 805.

§ *Pflüg. Arch.*, xc. Heft. 11 and 12. See also *Centralbl. Bakt.*, x. (1903) pp. 252-61.

also on other plants. He found that invertin had a great power of resisting the effect of alcohol. Another series of experiments was made to test the effect of acids.

Assimilation and other functions of the protoplasm were not hindered by the presence of 1 p.c. of acid, but most enzymes were weakened if not destroyed.

**Proteolytic Ferments.\***—M. Javillier continues his researches on the ferments present in the higher plants. He finds in the cell-sap of the ivy and many other plants a casease which carries the digestion of casein beyond the peptone to the acid-amide stage, quite comparable with that which M. Duclaux has discovered in culture liquids of *Tyrothrix*. The sap of the ivy also contains a gelatinase, that is to say, the enzyme liquefying gelatin, which is so wide spread among microbes, yeasts, moulds, and phanerogams, but which fails to digest coagulated egg-albumin or fibrin, either in an alkaline, neutral, or acid medium. The author's experiments, besides extending to the higher plants the existence of the casease which has hitherto been known for microbes and fungi, denote for it an individuality comparable with that of trypsin, reserving this name for the ferment which digests fibrin and egg-albumin in a neutral or alkaline medium. They show further that casease and gelatinase are two allied enzymes with parallel properties, or are perhaps identical.

The author finds also in the ivy the ferment discovered by Cohnheim in the intestinal secretion of mammals, namely, erepsin, which while unable to attack albumen or fibrin, transforms peptones and albumoses into crystallisable products.

#### General.

**Origin of Angiosperms.†**—J. M. Coulter discusses the common or independent origin of Monocotyledons and Dicotyledons, the conclusion being reached that they are independent lines. In case the two groups prove to have a common origin, evidence is advanced to show that the Monocotyledons represent a specialised offshot from the Dicotyledons, contrary to the recent general impression that the Monocotyledons are the more primitive. The origin of Angiosperms from Gymnosperms is shown to be untenable; and even such heterosporous Pteridophytes as *Isoetes* and *Selaginella* are very improbable ancestral forms. The general conclusion is reached that the Angiosperms have been directly derived from the eusporangiate Ferns, the transition forms to the Monocotyledons being unknown; but the transition forms to Dicotyledons being represented by the abundant and problematical "Proangiosperms" of the early Cretaceous.

**Myrmecophily in *Macaranga triloba*.‡**—Winifred Smith suggests the occurrence of myrmecophily, as a result of examination of limited material brought from Singapore. The internodes of the young stem are hollow, and in them were found adult ants with pupæ and larvæ.

\* Comptes Rendus. cxxxvi. (1903) pp. 1013-5.

† 'Phylogeny of Angiosperms.' Reprint from the University of Chicago Decennial Publications, ser. 1, x. (1903) 6 pp. 4to.

‡ New Phytologist, ii. (1903) pp. 79-82 (2 pls.).

Cup-shaped extra-nuptial nectaries occur at the serrated tips of the leaves, and food-bodies, which may contain proteid material, are found on the inner protected surface of the stipules. There is, however, no evidence that the presence of the ants is in any way an advantage to the plant.

**Monograph of the Genus *Cardamine*.**\*—O. E. Schulz gives a general account of the morphology of the genus, followed by a discussion of its affinities, geographical distribution, and the hypothetical origin of its subdivisions. The larger part of the paper is occupied by a systematic account of the genus and its species, with full descriptions and notes on distribution.

**African Flora.**†—The continuation of this work under the editorship of Dr. Engler comprises mainly a description of new genera and species in the following orders of seed-plants:—Capparidaceæ and Ochnaceæ (by E. Gilg), Euphorbiaceæ (by F. Pax), Verbenaceæ and Malvaceæ (by M. Gürke), Tiliaceæ, Sterculiaceæ, Apocynaceæ, Asclepiadaceæ, Bignoniaceæ, Rubiaceæ, and Commelinaceæ (by K. Schumann), and Myristicaceæ (by O. Warburg).

**Flora of Ferro.**‡—I. Bornmüller describes a new species of *Senecio* (*S. Murrayi*) from the island and gives a brief general account of the flora of this small member of the Canary group, and “the most western point of the old world.”

**Bermuda Islands.**§—A. E. Verrill gives an account of the character and origin of the original flora of the islands, as far as is possible from available information, and discusses the destructive effect upon it of the wild hogs (before 1612) and of the plague of wood-rats (1614–18). Drouths and the extensive deforesting of the islands by the earlier settlers also had a prejudicial effect on the native vegetation. The author gives an interesting historical account of the principal trees—the Bermuda palmetto, cedar and yellow-wood, and a list of the more important introduced plants including weeds.

**Mexican Leguminosæ.**||—M. Micheli has given a systematic account of the members of this family collected by Engène Langlissé in the States of Michoacan and Guerrero. A new genus, *Goldmannia* (*Mimoseæ*) and a large number of new species are described, and illustrated in excellent quarto plates.

**Amazon Flora.**¶—T. Huber gives a botanical account of the rubber-yielding plants of this region, and describes two new species, *Hevea viridis* and *Sapium Marmieri*.

The same author\*\* supplies a systematic list, with descriptions of new species, of the ferns and flowering plants collected or observed in

\* Engler, Bot. Jahrb., xxxii. (1903) pp. 280–416.

† Op. cit., xxxiii. (1903) pp. 209–384. ‡ Tom. cit., Beibl. 72, pp. 1–14.

§ ‘The Bermuda Islands.’ Trans. Connect. Acad. Arts. and Sci., xi. (1902) pp. 413–956 (40 pls. and figs. in text). ‘Changes in the Flora due to Man,’ pp. 571–658.

|| Mém. Soc. Physiq. et Hist. Nat. Genève, xxxiv. (1903) pp. 243–94 (28 pls.).

¶ Bolet. Mus. Para., iii. (1902) pp. 345–69.

\*\* Op. cit., pp. 490–8 (map and 4 pls.).

the region of the "Furos de Breves," and also contributes a general account of the physical geography and vegetation of the area, illustrated by a map, sections, and photographic reproductions.

ARCANGELI, ALCESTE.—*Il mimetismo nel regno vegetale.* (Mimicry in the plant world.) *Atti d. Soc. Tosc. Sci. Nat. (Pisa) Memor.*, XIX. (1903) pp. 268-329 (1 pl.).

SESTINI, FAUSTO.—*Studi sulla composizione chimica delle Foglie del gelso.* (Study of the chemical composition of the mulberry-leaf.) *Atti d. Soc. Tosc. Sci. Nat. (Pisa) Memor.*, XIX. (1903) pp. 330-9.

VOGLER, P.—*Variationskurven bei Pflanzen mit tetrameren Blüten.* (Variation-curves in plants with tetramerous flowers.) *Vierteljahrsschr. Naturforsch. Ges. Zürich*, XI.VII. (1903) pp. 429-36 (4 figs.).

WOLF, E.—*Neue asiatische Weiden.* (New Asiatic willows.) *Engler, Bot. Jahrb.*, XXXII. (1903) pp. 275-9.

## CRYPTOGAMS.

### Bryophyta.

**Morphology of Muscineæ.\***—F. Vaupel endeavours to clear up some morphological questions. As to the inflorescence of *Mnium*, he finds it to be of compound origin, the first antheridium arising from the apical cell, the latest segments of which are used up in forming other antheridia. It is also of compound origin in *Polytrichum*; but here the apical cell gives rise to the last antheridia. Certain cells of the paraphyses of *Mnium* and *Polytrichum*, and of the antheridia of the latter, form a brown substance, the function of which is to collect water for the benefit of the antheridia. As to the mechanism by which the antherozoids of hepatics are expelled, it is by the swelling of mucous matter in the antheridial-wall cells. The author also describes the structure of the rhizoid-bundles of the Polytrichaceæ and shows that their function is to conduct water as well as to attach the plant, and that they produce buds.

**Rhizoids of Mosses.†**—H. Paul joins issue with the views of Haberlandt, and partly with those of Goebel, as to the function of the rhizoids, and accepts those of Detmer. For he finds that the main function of rhizoids is purely mechanical, namely to fasten the protonema or the plant or parts of the plant to the substratum; and that such other functions as absorption of water, &c., are subsidiary. As a proof of this he notes that the rhizoids are most strongly developed where they are most needed as organs of attachment, for instance in epiphytic mosses. The existence of saprophytism in mosses he thinks to be doubtful for certain reasons which he gives. As to saxicolous species, it cannot be shown that their rhizoids attack the stone; it is rather the water which is held in the tuft that dissolves the substratum. The rhizoids of submersed species are thicker and stronger in proportion to the strength of the current. Floating mosses have no rhizoids at all; and it is a strong argument that throughout the moss kingdom rhizoids are not produced where organs of attachment are not needed.

\* *Flora*, xcii. (1903) pp. 346-70.

† *Engler, Bot. Jahrb.*, xxxii. (1903) pp. 231-74.

**Chromosomes of *Funaria hygrometrica*.**\*—R. Beer describes a simple method by which the distribution and number of the chromosomes in the dividing cells of mosses can be easily studied, despite the smallness of the nuclei. A preparation of living spore mother-cells, having been teased out in a physiological salt solution, was irrigated with a little 1 per cent. potash solution containing a trace of Congo-red. The chromosomes were immediately revealed distinctly, and were seen to number four in the dividing cell and to be of a long rod-shape. By division eight daughter-chromosomes are produced, four of which travel to each pole.

**European Mosses.**†—G. Roth is issuing a general illustrated flora of the mosses of Europe, which will occupy two volumes to be published in ten or twelve parts of 128 pages and 10 plates each. The total cost will be nearly 3*l*. The first part contains the general introduction and some of the cleistocarpous mosses. The author describes the main anatomical features of the mosses, their modes of reproduction, their distribution according to zones, soil, &c., and the part they play in the economy of nature. He discusses the collecting and naming of specimens, and the principal schemes of classification, and adds an extensive bibliography. In the special systematic part of the work he provides descriptions of the tribes, families, genera, species, &c., with notes on the distribution, and figures each species.

**American Mosses.**‡—A. J. Grout is issuing a non-technical handbook of the more common mosses of the north-eastern United States, which will be completed in four or five parts, each costing a dollar. The purpose is to enable students to identify with facility some 200 species, and to supply them with a knowledge of the structure and natural history of the plant. The work is freely illustrated with figures from standard works, and where necessary contains keys to the families, genera, and species. The introduction treats of classification, collection and preservation of specimens, methods of microscopical examination, life-history and structure of the plants. An illustrated glossary is provided. The descriptions are written in simple language, and are not encumbered with unnecessary details.

**Asexual Reproduction.**§—F. Cavers gives a résumé of the principal results which have been published hitherto upon asexual reproduction in hepatics, together with some new observations of his own. He passes in review the tribes and families of the order, calling attention to the various modes of this form of propagation that have been observed in numerous species. Broadly speaking, it is accomplished in three ways—either by the death of the old parts and the setting free of the younger parts or branches as independent plants; or by the production of specialised gemmæ; or by the detaching of caducous adventive shoots. In some species of *Anthoceros* asexual propagation takes place by means of tubers. As long ago as 1774 Necker describes the process of regenera-

\* *New Phytologist*, ii. (1903) p. 166.

† 'Die Europäischen Laubmoose,' Leipzig, 1903, 128 pp.

‡ 'Mosses with Hand-Lens and Microscope,' New York, 1903, part i., 86 pp., 10 plates, and 81 figs. in text.

§ *New Phytologist*, ii. (1903) pp. 121-33, 155-65 (8 figs. in text).

tion of the gametophyte from small fragments of the plant; and later writers have shown that practically every cell possesses a latent capacity for regenerating the whole plant. Apospory has been observed by W. H. Lang in *Anthoceros lævis*, fragments of the sporogonial wall having been cultivated into young gametophyte thalli.

**Biology of Hepaticæ.\***—F. Cavers publishes notes on some points in the biology of hepatics, limiting his remarks to the vegetative organs and the various ways in which these are adapted to the needs of the plants. Treating principally of British genera and in particular of the thalloid forms, and illustrating his points with figured sections of the plants, he brings out the main differences of structure, air-cavities, stomata, assimilative tissues, mucilage cells, ventral scales, &c., and shows what part they play in the life of the plant and how they may be modified to suit a change of environment.

### Thallophyta.

#### Algæ.

**Fresh-water Algæ.†**—W. Schmidle publishes some critical notes on several genera. He finds that the difference between *Hæmatococcus* and *Chlamydomonas* is quite marked. He has studied *H. Bütschlii* and *H. pluvialis* and finds that a nucleus is always present in the centre of the cell and is always surrounded by a red oil-drop, which renders the nucleus indistinct. The size of the red spot varies greatly and from it the protoplasm extends on all sides, passing over into the chromatophore, and apparently penetrating into the pseudopodia. The chromatophore is described, as well as all other details of the cell-structure, and the author is of opinion that *Hæmatococcus* and *Chlamydomonas* cannot even be regarded as belonging to the same family.

On the other hand, *Stephanosphaera pluvialis* Cohn is regarded by the author as being closely connected with *Hæmatococcus Bütschlii*, and he suggests the name of Sphærellaceæ for a sub-family of Chlamydomonadineæ, to include these two genera.

Then follow remarks on *Chlamydomonas* and *Chlorogonium*. The former genus has an extremely variable chromatophore, but as the forms it assumes fall more or less into two types, the author divides the genus into two sections, *Euchlamydomonas* and *Chlorogoniella*. The species belonging to each section are enumerated. An amended description is given of *Chlamydomonas mucicola* Schmidle, and points of relationship are shown between *Chlamydomonas* and *Chlorogonium*.

*Charteria* forms the subject of the next note, and a new species, *C. alpina*, is described. The genus is divided by the author into two groups: one having the pyrenoid in front of the nucleus = *Corbiera*, and the other having the pyrenoid behind the nucleus = *Eucharteria*. A key is given to the species in each group.

The species of *Chloromonas* Gobi are next dealt with, a new species is described, *C. alatina*, and a key to the species of the genus is given.

\* Naturalist, 1903, pp. 169-76; 208-15 (12 figs. in text).

† Ber. Deutsch. Bot. Gesell., xxi. (1903) pp. 346-55 (1 pl.).

Finally two new genera are described, each containing one species, *Planctonema Lauterborni* and *Dictyosphaeriopsis palatina*.

**Nuclear Stains for Fresh-water Algæ.\***—Catherine Hillesheim has tried various fixing and staining agents for species of *Spirogyra*, *Zygnema*, *Microspora*, and *Hormiscia zonata*; also for species of *Cladophora* and for *Hydrodictyon reticulatum*. The best fixing agent was chromic acid, and the most successful stain was a mixture of borax and ammonia carmine, in equal quantities.

**Dictyosphaeria favulosa.†**—Caroline M. Crosby has been able to add to our previous knowledge of this species in certain details. She regards *Dictyosphaeria* as a low type of Valoniaceæ because of (1) the primitive, closely appressed branched system, and (2) the well-developed rhizoids.

Under histology she deals with the structure of the "cell-walls"; the "inner cell-strengthening," which she describes in detail; and the "external cell-strengthening" by means of haptera. The origin and development of the haptera are then described, as well as the rhizoids. Under cell-contents, the author treats of the endochrome, pyrenoid, starch-grains, oil-drops, and cell-sap.

**Stapfia cylindrica.‡**—C. J. Brand finds this alga on the north shore of Lake Superior and compares it with the plants of Nordstedt, Wittrock, and Lagerheim No. 1362, distributed under the name of *Tetraspora cylindrica* Ag. f. *enteromorphoides* Lagerheim. He also compares it with the specimens distributed by Rabenhorst as No. 2244, *Tetraspora cylindrica*, and draws up a diagnosis of the Lake Superior plant.

**Algological Notes.§**—Under this heading N. Wille continues the record of his studies on the lower algæ. Note ix. contains an account of a new *Carteria*, *C. subcordiformis*, found in fresh-water puddles in places where fish are dried near Aalesund in Norway. Other species belonging to *Chlamydomonas* and *Brachiomonas* were found with it.

The genus *Sphaerella* is the subject of note x. This is synonymous with *Hæmatococcus* Ag. and the author points out the great difficulty of distinguishing the genera *Hæmatococcus* Ag. (= *Sphaerella* Somm., *Chlamydococcus* A. Br., &c.) and *Chlamydomonas* Ehr. He is inclined to regard as an important character the presence or absence of pseudopodia, and to reject any distinction founded on hæmatochrome. He separates *Sphaerella nivalis* Somm. from *Hæmatococcus* and places it in *Chlamydomonas*. For the former genus he draws up a generic diagnosis and places in it the two species, *H. pluvialis* Flotow and *H. Bütschlii* Blochmann. For both species he gives full synonymy and description. A list follows of six species which the author excludes from *Hæmatococcus*, with references and remarks.

Note xi. contains a morphological and systematic account of the genus *Chlamydomonas*. The various polymorphic stages of the species

\* Minnesota Bot. Studies, iii. (1903) pp. 57-9 (1 pl.).

† Tom. cit., pp. 61-70 (1 pl.).

‡ Tom. cit., pp. 71-4 (1 pl.).

§ Nyt Mag. Naturvidenskab., xli. (1903) pp. 89-185 (2 pls.).



are described, and the likeness between this genus and *Chloromonas Gobi* is discussed. A genealogical tree of these and allied genera shows the author's views as to the relationship existing between them, starting from Polyblepharidææ. Certain new species are described very fully and a key is given of the species of *Chlamydomonas* and *Chloromonas*, followed by descriptions of the less known species. Finally 23 doubtful species are enumerated which are either incapable of identification or cannot be included in either of the above genera. References and notes accompany each name.

Note xii. shows that *Sphaerocystis Schræteri* Chod. is identical with *Glaucococcus mucosus* A. Br., and the author agrees with A. Braun that its systematic position is with the Chlamydomonaceæ, rather than with the Palmellaceæ, where Chodat placed his species. The author considers that the genus *Glaucococcus* together with *Chlorogonium* and *Physocytium* form a connecting link between *Chlamydomonas* and Tetrasporaceæ.

Note xiii. deals with *Pteromonas nivalis* Chodat, which according to the author is already known as *Astasia nivalis* Shuttleworth. The material at his disposal does not allow him to pronounce definitely on the true position of the species, but he is inclined to regard it as representing a new genus. He gives details as to the structure and cell-contents.

In note xiv. the author shows that *Cerasterias nivalis* Bohlin must not only be excluded from that genus but must be reckoned as a fungus. The name *Chionaster* is proposed for it and a description of the genus is drawn up. It is suggested that it may belong to the Chytridineæ or it may represent a special family; and that it has branched off from the algal genus *Tetraëdron*, having adopted a saprophytic mode of life and so lost its chlorophyll.

**Spores of Vaucheria.\***—H. C. Bastian describes stages in the resting and germinating spores of *V. racemosa*. He finds in each resting spore one or more heaps of pigment-granules, the refuse products of molecular transformation. They are unsurrounded by any bounding membrane. In the germinating spore these pigment-heaps are said by the author to appear as perfect spheres with sharply defined outlines and gradually to exhibit independent movement. He considers that these bodies pass through certain definite developmental phases and eventually become independent amœboid animal organisms, which have taken origin from the substance of the *Vaucheria* plant.

**Nitella batrachosperma.†**—G. Lilley redescribes and figures this plant. It grows somewhat scantily in very shallow water in Pike Lake near Duluth, and has a wide distribution in Europe and has been reported from Australia.

**Chlorochytrium.‡**—H. Charlton Bastian has examined specimens of *Lemna minor*, *L. gibba*, and *L. trisulca*, and has studied the various stages of *Chlorochytrium Knyanum* growing within the intercellular spaces

\* Ann. Mag. Nat. Hist., xii. (1903) pp. 166-74 (1 pl.).

† Minnesota Bot. Studies, iii. (1903) pp. 79-82 (1 pl.).

‡ Ann. Mag. Nat. Hist., xii. (1903) pp. 175-86 (1 pl.).

of their leaves. He describes and figures various stages in the life-history of the *Chlorochytrium* and states that the fission-products of the alga are often associated with diatoms. These diatoms appear to be almost always immature, and the author can only account for their presence inside the *Lemna* by one of two hypotheses. Either (a) the diatoms have, like the algæ, entered through the stomata; or (b) they have been produced *in situ* by a transformation of the fission-products of the alga. A certain number of reasons are adduced to show that the latter of the two hypotheses is in the author's opinion the correct one.

**Structure and Division of Diatoms.\***—C. Mereschkowsky publishes a preliminary report of his latest researches on this subject. He gives details of the structure and manner of division of *Pinnularia*, *Navicula*, *Gyrosigma*, *Stauroneis*, *Neidium*, *Achnanthyidium*, *Cymbella*, a new genus *Placoneis*, *Sellaphora*, *Microneis*, *Eunotia*, *Nitzschia*, *Hantzschia*, *Campylodiscus*, *Surirella*, *Stenopterobia* (of which the author describes a new species), *Amphiprora*, *Stauronella*, *Tabellaria*, and *Fragilaria*. Figures are given showing the division in most of these genera. The author concludes his paper by a note on the "law of alternation of the plane of division." He finds that along the line of evolution the plane of division changes regularly and alternately from longitudinal to transverse, from group to group. Thus, if one follows the line of evolution of the Raphideæ, the genus *Libellus*, which may be considered the general ancestor of the Polyplacatæ, divides longitudinally. The next group, Diplacatæ, represented by *Navicula*, &c., divides transversely. Tetraplacatæ, the following group, divides longitudinally, and so on. The author does not attempt to explain this interesting fact, but he suggests that there may be something in common between the alternation in the division of the growing points of such algæ as *Sphacelaria*, *Chactopteris*, *Cladostephus*, &c., and the alternation of division in the successive groups of diatoms. In the one case the time occupied to produce the alternation is limited to the formation of successive cells in one and the same plant; in the other case a change of the plane of division demands an immense length of time, sufficient for the evolution of a new group.

**Auxospores of Diatoms.†**—C. Mereschkowsky gives a full and lucid account of the various types of auxospore and their mode of formation. In doing so he disagrees on certain points with G. Karsten, principally concerning the evolution of the types and their respective order of development. As presented by Mereschkowsky, the auxospores may be divided into two classes: (1) Asexual auxospores, formed without copulation and from a single individual; and (2) sexual auxospores, formed by the copulation of two cells. These classes are found to coincide with the division of diatoms into immobile and mobile, the asexual auxospores being characteristic of immobile, the sexual auxospores of mobile species. The fact that these two forms of classification on different lines coincide, strengthens the present author in his views as to the evolution of the various types.

\* Bull. Soc. Imp. Nat. Moscou, No. 1 (1903) pp. 149-72.

† Ann. Sci. Nat., xvii. (1903) pp. 225-62 (20 figs. in text).

The first class is divided into two types. I. An auxospore formed of a single mother-cell (in this division there is one sub-type). II. Two auxospores formed from a single mother-cell (here there are two sub-types).

The second class contains three types: III. Two mother-cells divide into two sister-cells, each half copulating with the half of the other individual and forming an auxospore.

IV. Two cells form an auxospore (there is a sub-type here to contain *Cocconeis*). V. Two cells come into contact but do not copulate, producing two auxospores,—reduced sexuality.

Details are given concerning the behaviour of the nucleus and nucleolus in these various types, as well as explanatory figures and diagrams. Finally, genealogical trees showing the views of the author and those of Karsten concerning the evolution of diatoms, place the divergence of views clearly before the reader, and the respective arguments are set forth in the text.

**Endochrome of Diatoms.\***—C. Mereschowsky publishes the first part of his studies on this subject and treats therein more especially of facts concerning the Raphidieæ and the Nitzschieæ. A more or less detailed account is given of the interior structure of 125 species and varieties of 19 genera belonging to these groups. As regards the endochrome of the family Pleurosigmeæ, the author finds that Cleve's distinction between *Pleurosigma* and *Gyrosigma* is quite correct, *Pleurosigma* possessing four tortuous bands, and *Gyrosigma* two (in the case of *G. rectum* four) plates. The division of diatoms into Coccochromeæ and Placochromeæ should, according to the author, be definitely abandoned, as being without sound foundation. The study of the endochrome as a generic character has little value, but as a specific character it is of the deepest importance. The "primary" elæoplasts, as distinguished from the "secondary" or "supplementary" ones, are also shown to be constant in form, and therefore of value in systematic determination. The paper is well illustrated.

**Melosira.†**—O. Müller discusses the occurrence of a possible variation without intermediate stages, in certain species of *Melosira*. He has found threads which are composed of individual diatoms having pores of large size and others with pores of small size, and some threads composed of both kinds. All three kinds of threads are perfectly distinct in appearance. The specimens examined and compared come from the Lake of Nyassa and the Müggel-See, near Berlin. He regards the coarse-pored Müggel-See plant as *Melosira granulata* Ralfs, and makes two sub-species: *M. mutabilis* with joints showing both sizes of pore, and *M. punctata*, with fine round pores. The coarse-pored species from Lake Nyassa he calls *M. Nyassensis*, and this is also divided into two sub-species: *M. de Vriesii* with mixed pores, and *M. bacillosa* with fine rod-like pores. The diagnoses are promised in a later paper in *Engler's Jahrbuch*. The author refuses to recognise *M. crenulata* var. *ambigua*

\* Mem. Acad. Imp. Sci. St. Pétersbourg, ser. 8, xi. No. 6 (1901) 140 pp., 7 pls. (figs. in text).

† Ber. Deutsch. Bot. Ges., xxi. (1903) pp. 326-33 (1 pl.).

Grun. as a variety of *M. crenulata* and suggests it be called *M. ambigua* (Grun.). The sub-species with mixed pores he would call *M. variata*, and that with fine pores *M. puncticulosa*.

*Cyclotella bodanica* var. *lemanica*.\*—H. Bachmann has made a special study of this diatom from specimens collected by him in the Lake of Lucerne, where it may be found all the year round. He describes the methods of collecting the material, which he studied in the fresh condition, though he was unable to cultivate it himself. A description of the genus *Cyclotella* is given, describing minutely the various external and internal characteristics. The species studied was never found in colonies. Tables then follow which show the seasonal occurrence at different heights in different parts of the lake, illustrated by a small map and by two diagrams (charts?). The rest of the paper is devoted to the subject of the reproduction of *Cyclotella*, (1) by cell-division; and (2) by the formation of auxospores. Cell-division is always preceded by the division of the nucleus. As regards the type of auxospore formation, the author finds that it comes under the fourth of Karsten's classes, like most plankton-diatoms, of which the characteristic is that "An auxospore arises from one mother-cell by suppressed division." The author has often followed the formation of the auxospore in its early condition and describes the process in detail. He finds that auxospores occur most frequently in *Cyclotella lemanica* in November and December, lasting on into May and being entirely wanting in the summer; and since this form of reproduction is largely dependent on outward influences, he presumes that in the case of this diatom their appearance is connected with change of temperature. The impulse towards the formation of auxospores is given by the protoplasm, not by the nucleus.

**Diatoms of Auvergne.**†—J. Héribaud collects together all the records he has made since 1893 up to the present time of the diatoms of Auvergne, and arranges them according to the classification of the raphe, following in the main the lines of Van Heurck, but slightly modified by the work of Cleve and Peragallo. He enumerates 908 forms, of which 564 are species and 344 varieties: 281 are new. In the tertiary deposits of the upper Loire and of Ardèche the author finds 37 forms, mostly new to science.

**Diatoms of the Atlantic.**‡—G. Murray publishes some notes on Diatomaceæ collected by the pumping method, principally by himself and V. H. Blackman, during a voyage to the West Indies in 1897, and in subsequent voyages by other collectors in the same year. It was found that a small number of species occur constantly, but sparsely, in the open ocean, varying with the temperature. As land was approached the diatom-flora increased in quantity and variety, showing its coastal character. A series of collections made in the warm waters near Colon from July to December is noteworthy for the richness and constancy of its diatom-flora. The samples were submitted to T. Comber for deter-

\* *Jahrb. wiss. Bot.*, xxxix. (1903) pp. 106-31.

† *Disposition méth. d. Diatomées d'Auvergne*, Klinksieck, 1903. See also *Nouv. Notar.*, xiv. (1903) p. 122.

‡ *Journ. Bot.*, xli. (1903) pp. 275-77.

mination, and his description of a new species, *Nitzschia producta*, is included.

**Fossil Diatoms.\***—H. Reichelt describes the result of his researches into the diatomaceous deposits of Bachseldorf, Zantig and Sulloditz. The first of these is characterised by the presence of *Melosira distans* Ehr., together with *M. undulata*, *M. granulata*, *Gomphopleura nobilis*, &c. The second contains mostly *Melosira distans*, often in the auxospore condition. The third abounds in specimens of *Melosira crenulata*, *M. undulata*, and *Tetracyclus ellipticus*. Among the 16 species recorded, 3 are new: *Melosira Hibschi*, *Navicula Hermannii*, and *Gomphopleura nobilis*.

J. Pantocsek † describes and figures certain fossil diatoms from the andesite tufa near Szliacs. The formation is characterised by a new genus *Szechenia*, different species of *Eunotia*, *Navicula arata* Grun., *N. Haueri* Grun., *Cocconeis Boryana* Pant., and *Melosira undulata* Kütz. The last species has also been found in other Hungarian deposits as well as living in fresh water in the island of Java; thus demonstrating the similarity which exists between the flora of that period and that of the islands of Sunda at this day. Thirty-eight species and varieties are figured, including *Semseya hungarica* Pant., and *Disiphonia hungarica* Pant.

H. Heiden ‡ has examined diatoms from deposits of Warnemünde harbour, and from the Convent Lake. In the former are to be found many marine species allied to those at present flourishing in southern seas. Three fresh-water species are also recorded. An examination of the Convent Lake deposits shows an entirely different flora from that of Warnemünde Harbour. In all 308 forms are recorded in this paper, the most interesting of which are followed by notes on their geographical distribution. The respective occurrences of forms in the different samples is also given. One new species is described: *Navicula Rosstockiensis*.

**Diatom Records.§**—R. H. Philip records the existence of *Surirella medulica* Per. in fresh water at Hotham Carrs near Hull. It is a brackish-water diatom previously recorded from Médoc in the south of France. It may be a survival from some remote marine flood more than a century ago.

G. B. De Toni and A. Forti || enumerate 24 species from Lake Ngebel, in Java, of which eight are new records for the island.

**Egrecia Menziesii.¶**—F. Ramaley has made a study of this alga and publishes the results under the following headings:—Distribution; External Morphology, in which the various parts of the plant are treated separately and in detail; Comparison with other Laminariaceæ; Anatomy, also treated in detail. The author considers that the morphology of *Egrecia* is best understood if considered as an *Alaria* with

\* Ber. Naturforsch. Ges. Leipzig, 1897–1900. See also Nuov. Notar., xiv. (1903) p. 121.

† Nuov. Notar., l.c. p. 127.

‡ Mitth. v. d. Gr. Mecklemb. Geolog. Landesanstalt, 1902. See also Nuov. Notar. l.c. pp. 123, 124.

§ Naturalist, 1903, p. 256 (figs. in text).

|| Bull. Soc. Bot. Ital., 1903, pp. 133–41.

¶ Minnesota Bot. Studies, iii. (1903) pp. 1–9 (4 pls.).

certain modifications. It agrees fairly closely with other Laminariaceæ in its anatomy. Mucilage canals however do not occur, and no cryptostomata were seen.

*Pelvetia fastigiata*.\*—F. L. Holtz publishes observations on this species, treating the various parts of the plant in detail. Both external appearance and internal structure are fully described, and the development of the conceptacle is treated at length. He disagrees with F. O. Bower in certain points connected with the early stages of the development of the conceptacle, being of opinion that it originates from several contiguous epidermal cells, and not from one central basal cell. The stages of growth seen by the author are figured. The antheridia arise sometimes on branched hairs, sometimes on simple pedicel-cells from the wall of the conceptacle. The plant is hermaphrodite. Methods of staining and sectioning are described.

**New Alaria.**†—H. F. Schrader describes and figures a new species of *Alaria*, *A. nana*, found by him at the Minnesota Seaside Station, growing in very exposed situations and always beaten about by the surf. The plant is small, 30–50 cm. long, the holdfast does not show any growth-rings, and the growth of the stipe in thickness is radial. There are neither mucilage-ducts nor cryptostomata. The sori are borne on gonidiophylls which are produced laterally on the stipe. The paraphyses have large, thick, mucilaginous caps as in *Lessonia* and *Pterygophora*.

**Polymorphism of Marine Algæ.**‡—F. Tobler has experimented on six species of Florideæ with regard to polymorphism, and publishes a list of the various forms each species may assume under different conditions. His experiments include growth in darkness and in light and at different times of year. He was able to compare the results of his artificial growth with the growth of algæ thrown up on the shore after storms, since certain of such plants continued to grow, but in abnormal manner. One result of his observations, which he considers among the most important, is the dissolving of the connection between the different cells of an alga, not as a forerunner of decay, but as an introduction to active independent life on the part of the individual cells. He discusses the question of polarity in connection with the growth of these isolated cells, and touches on the subject of seasonal forms of one and the same species. Further information on various points connected with this subject is promised later.

**New Rhododermis.**§ — F. Heydrich describes and figures a new species of *Rhododermis*, *R. Van Heurckii*, which grows on young *Zostera* leaves off the coast of Jersey. In its young stages the thallus shows the characteristics of the genus, but in later stages the new species varies in certain points. In some cases as soon as the first tetrasporangia have been emptied from that part of the plant which grows over the sharp edge of the *Zostera* leaf, the thallus swells up and forms irregular kidney-shaped outgrowths, which hang somewhat over the edge of the host-plant. In other specimens the internal cells may vary in

\* Minnesota Bot. Studies, iii. (1903), pp. 23–45 (6 pls.).

† Tom. eit., pp. 157–65 (4 pls.).

‡ S.B. K. Preuss. Akad. Wissensch., xviii. (1903) pp. 372–84.

§ Beih. Bot. Centralbl., xiv. (1903) pp. 243–6 (1 pl.).

other ways than swelling. *R. Van Heurckii* differs from *R. parasitica* in having a simple basal disc of attachment, with no penetrating rhizoids. Hairs sometimes occur on the thallus of mature plants, arising from the lowest portion of a superficial cell. The chromatophores resemble those of *R. parasitica*. The tetrasporangia are distributed in irregular sori over the entire surface of the plant, and are accompanied by curved paraphyses.

**Reparation of Injury in Ceramiaceæ.\***—F. Tobler describes and figures the manner in which the large cells of *Bornetia secundiflora* and *Griffithsia Schousboei* behave after having suffered some injury. He finds that the protoplasm withdraws to the wall furthest removed from the scene of the injury and clothes itself with another membrane, often throwing out at the same time adventitious growths. The new cell thus formed may be more or less curved and U-shaped, and it lies within the torn and dead walls of the injured cell. Sometimes the protoplasm divides into two portions and two distinct filaments start from the same base. If a cell of *Bornetia* were isolated, the neighbouring cells on either side having been injured, the protoplasm was seen to divide and congregate at both ends. It might then continue a filamentous growth after a partition-wall had been formed between the two masses of protoplasm; or the protoplasm might once more become diffused throughout the cell, then collect in one end and, after the formation of a partition-wall, grow out into a new filament.

**Trichoglœa lubrica.†**—F. K. Butters makes some observations on this plant concerning the anatomy, the minute structure of the vegetative tract, the cytology of the vegetative tract, and the reproductive organs. The author finds that while *T. lubrica* agrees very closely with *Liagora* as regards the structure of the vegetative tract; in the reproductive tract, especially in the structure of the cystocarps, it most nearly resembles *Nematium*.

**New Nitophyllum.‡**—A. Mazza gives a description of a species of *Nitophyllum*, *N. tristromaticum* Rodrig., found by himself at the port of Messina, and previously by Rodriguez at the port of Mahon in Minorca. A section of the thallus shows distinct layers of cells: the cortical, composed of a single series of small, subquadratic cells; and the central layer, composed also of a single series of cells which are either of the same form as the cortical ones or ellipsoidal, but twice the size. The plant, 3 cm. high, arises from a very short stalk, is fan-shaped, and has the upper half much divided. The margins of these divisions bear many proliferations and rootlets, and the author suggests that by means of these rootlets the plant can propagate itself after laceration of the thallus has taken place. The rootlets are of the same colour, rose-purple, as the thallus. The plant has been found no nearer the surface of the sea than 60 metres. Only immature tetraspores have been seen.

**Galaxaura adriatica Zan.§**—T. Bentivoglio records this alga from Taranto and states that it is not so rare a plant as has been commonly

\* Ber. Deutsch. Bot. Gesell., xxi. (1903) pp. 291-300 (1 pl.).

† Minnesota Bot. Studies, iii. (1903) pp. 11-21 (2 pls.).

‡ Nuov. Notar., xiv. (1903) pp. 106-8. § Tom. cit., pp. 109-12.

supposed. It possesses a very robust radical disc and is so firmly attached to rocks that a storm or heavy seas are required to break it off. Hence it is rarely found washed up.

**Florideæ.\***—J. B. De Toni publishes the third section of the fourth volume of his *Sylloge Algarum*, which consists of Families V. and VI., Rhodomelaceæ and Ceramiaceæ.

**Marine Algæ of Sicily.†**—V. Spinelli publishes a first contribution to the marine flora of Sicily, in which he enumerates 164 species, 37 of these being new to the island. A list of synonymy and references to literature are given under each species, together with its geographical distribution in the Mediterranean and the localities where it has been found in Sicily. In the introduction the author mentions the genera which he has found characteristic of the three zones, into which he has divided the region of vegetable life, according to the lines of Ardissonne. The first zone reaches from the high water-mark to a depth of three fathoms, the second from 3–20 fathoms, and the third from twenty to the lowest limit of marine vegetation. Certain species new to science have been discovered, but the description of these is promised in a later number. The microplankton of the Sicilian coast has not been included, and the region explored has been confined to the eastern shores between Syracuse and Messina.

**Fresh-water Algæ of certain Lakes.‡**—O. Amberg notes the occurrence in the Lago di Muzzano of 7 Myxophyceæ, 8 diatoms, 14 species of Chlorophyceæ, and 8 Peridinieæ. The commonest form appears to be *Clathrocystis æruginosa* Henfr., which is mixed with *Anabæna Catenula* B. and F., *A. circinalis* Hansg., *Botryococcus Braunii* Kütz., and *Celosphaerium Kuetzingianum* Naeg.

O. Zacharias § writes on the biological characteristics of the Klinkerteich at Plön, and remarks on the poverty of algæ. He records 34 species, among them a new variety, *Zachariasii* Brun., of *Stephanodiscus Hantzschianus* Grun. This variety is distinguished by the presence of long siliceous setæ (50–70  $\mu$ ) which are very fragile and become detached in drying. They are inserted on small spines disposed radially on the valve.

H. Reichelt || records 83 species and varieties of diatoms from the Schöhsee near Plön, among which are the new species *Navicula Zachariasii* and *Stauroneis tylophora*. These are also figured. The author seeks to explain the presence of certain species on geological grounds.

R. Monti ¶ publishes lists of diatoms and other algæ recorded from five small lakes in the region of the Val Formazza, called collectively the Laghi Ossolani.

E. Lemmermann \*\* has made a special study of four of the Plön

\* *Sylloge Algarum*, iv. sect. iii. (1903) pp. 775–1525.

† *Rendic. e Mem. R. Acc. Sci. etc. d. Zelanti Acireale*, ser. 3, i. (1903) No. vii. 66 pp.

‡ *Plöner Berichte*, 1903. See also *Nuov. Notar.*, xiv. (1903) pp. 117–19.

§ *Loc. cit.* || *Loc. cit.*

¶ 'Le condiz. fisic.-biol. d. laghi Ossolani. . . in rapp. alla Piscicoltura,' Milano e Pavia, 1903.

\*\* *Forsch.-ber. d. Biolog. Stat. z. Plön*; *Nuov. Notar.*, xiv. (1903) pp. 128–31.



lakes, which he treats in detail. He has worked out the periodicity of the diatoms and Myxophyceæ, and gives the characteristic species for the various months of the year as they occur in the Great Plön Lake. He finds that the colder seasons of the year are better suited to the prevalence of diatoms, and the warmer seasons for the Myxophyceæ. After a general comparison of the algal flora of the four lakes, the author gives observations on a certain number of species of *Lyngbya*, *Anabæna*, *Gloiothrichia*, &c.

O. Zacharias\* gives a list of the algæ which he finds respectively in six stagnant ponds in the neighbourhood of Plön. Many novelties are described and interesting species are recorded,—such as *Closterium lineæ* Perty, *C. Ceratium* Perty, *Vaucheria rhomboides* Bréb., in large quantity, *Navicula subtilissima* (determined by Reichelt), *Atractinium Schmidlei* Zach. nov. gen. et sp. near *Scenedesmus*, and *Selenococcus farcinalis* Schmidle et Zach., &c.

Tide-Pool Vegetation.†—S. A. Skinner has made a careful study of eight pools at Port Renfrew and publishes the result of his investigations, made both at high and low tide. He gives “the Location,” “Exposure to Tide,” “Shape and Dimensions,” and “Flora: Kind and Distribution” of each pool, and concludes his paper by a short summary of generalisations as to the effect on the algæ of wave-action, slope of the walls, and condition of the bottom. He also indicates other factors which would affect algal growth and commends these subjects of investigation to other botanists.

Algæ of the Gulf of Naples.‡—Angelo Mazza records in a list, which was begun last June, 189 species of marine algæ from the Gulf of Naples. He includes the records of Falkenberg and Berthold as well as his own collections. Critical notes are appended to many of the species-names.

Algæ from Central Asia and China.§—R. Gutwinski gives a list, mainly consisting of diatoms, of 173 species collected in various localities of Central Asia and China by Dr. J. Holderer. A list of twenty-two algæ collected by him has been already published in *Hedwigia*, xxxix. pp. 141–3, and the diatoms and other algæ here enumerated belong to the same collection, and include specimens from eighteen different localities. A plate shows several of the more interesting species, including three new varieties.

Fossil Algæ of North America.—D. White|| describes and figures two species of *Conostichus* Lesquereux (? *Acetabulariæ*), namely *C. Broadheadi* Lesq. and *C. prolifer* Lesq. from the Lower Coal Measures of Missouri.

The same author¶ describes a new genus of fossil algæ, *Thamno-cladus*, placing in it one species *T. Clarkei*, from the palæozoic strata of East Windsor. It differs from *Psilophyton* and recalls in appearance

\* Plöner Berichte, 1903. See also Nuov. Notar., xiv. (1903) pp. 124–6.

† Minnesota Bot. Studies, iii. (1903) pp. 145–55.

‡ Nuov. Notar., xiii. (1902) pp. 125–52; xiv. (1903) pp. 1–17, 97–105.

§ Bull. Intern. Acad. Sci. Cracovie, No. 4 (1903) pp. 201–26 (1 double plate).

|| ‘Fossil Flora of the Lower Coal Measures of Missouri,’ Washington, 1902.

¶ N. York State Paleontologist, 1901; Albany, 1902 (2 pls.).

the existing species *Haliseris delicatula* and *Stenogramma interrupta*. The paper includes also remarks on the fossil genus *Haliserites*, with special reference to *H. Dechenianus* Göpp.

From the Upper Silurian of Indiana the same author\* describes and figures two new species of *Buthotrephis*, *B. divaricata* (= *B. speciosa*) and *B. Newlini*. The name *speciosa* is suggested later as a substitute for *divaricata*, the latter having been already used for another alga, *B. divaricata* Kidston. Notes on the genus *Buthotrephis* are given, and a likeness is pointed out between this genus and *Liagora*.

**Origin of the Sporophyte.**†—B. M. Davis discusses this question from the point of view of the structural changes that occur in the cell-protoplasm at the time of fertilisation, such change being made visible at least in the alteration of the number of chromosomes in the nuclei. A gametophyte contains in each of its nuclei a fixed number of chromosomes proper to the plant; its fertilised egg has twice that number of chromosomes as the result of the fusion of two nuclei; the resulting sporophyte is also characterised by this double number of chromosomes until it produces asexual spores—in which the chromosomes revert to the original ancestral number as found in the gametophyte. In the higher animals the life-history is strikingly different; for here the gametes have half the normal number of chromosomes. Among plants the explanation must be sought amongst the lowest orders—the Thallophytes. But unfortunately we know almost nothing of what occurs in the Algæ and Fungi; and what we do know is confusing. Until their life-histories are properly understood we can only proceed by speculation. The author discusses the peculiar limited conditions that occur in *Fucus* and *Chara*; and then passes on to the cases of the Rhodophyceæ and Ascomycetes, which afford pronounced evidence of a Sporophyte generation. Similar tendencies are afforded also by *Cedogonium*, *Spheroplea*, *Ulothrix*, and the Conjugales; these also he discusses. The points emphasised are that the sporophyte is a phase intercalated after the fusion of the gametes—the protoplasm resulting from this fusion being structurally different from that of the gametophyte. It is wound up, as it were, to a higher pitch of vitality; and it tends to express itself in morphological developments, dependent on the environment. Finally, it reverts to the ancestral type of protoplasmic structure by producing asexual spores which lead back to the gametophyte phase.

#### Fungi.

**Notes on Monoblepharis.**‡—Roland Thaxter summarises the species of this genus, five in number. He dissents from Lagerheim's view that the genus should be split, two species being placed in *Diblepharis*, and considers that they form a well-defined and coherent group. Thaxter promises a thorough examination of the New England forms.

**Leptomitus lacteus.**§—R. Kolkwitz publishes preliminary notes on his research of this fungus. He found that it grew well on slices

\* Proc. U.S. Nat. Mus., xxix. pp. 261-70 (3 pls.); and Proc. Biol. Soc. Washington, xv. (1902) p. 86. See also Nuov. Notar., xiv. (1903) pp. 132, 144, 145.

† Amer. Natural., xxxvii. (1903) pp. 411-29.

‡ Rhodora, v. (1903) pp. 103-8 (6 figs.).

§ Ber. Bot. Ges., xxi. (1903) pp. 147-50.

of meal-worms, but the fungus had to be closely pressed on to the substratum. From material thus grown he infected gelatin plates and pepton-flesh extract bouillon. Any addition of soda had to be avoided; ordinary cooking salt, though not necessary, was harmless, hence the fungus can live in the sea. The author found no oospores, a resting stage is secured by persisting parts of the mycelium and by gemmæ. They are very resistant to the action of sulphuric and carbonic acids, ammonia and absence of oxygen. The cellulose grains stained with Congo red, thus attesting to the connection with cellulose. Membrane formations were occasionally found at the strictures of the hyphæ, something like the rings of *Edogonium*.

For nourishment the fungus demands chiefly nitrogenous compounds in solution. Carbohydrates are of slight importance. *Leptomitus* is usually found growing in running water at some little distance from an entering drain. The strongly alkaline or acid nature of the contents of the drain are thus somewhat diluted before coming in contact with the fungus, and the absence of bacteria is secured. It is usually found in winter, but this depends not so much on temperature as on the conditions of public works of which the drains supply the nutriment required by the fungus.

**Phycomycetes.\***—Fr. Bubak describes a new species *Entomophthora Lauxanicæ* which he found on mummified flies on the under side of leaves of *Spiræa*. There were no conidia, but the resting spores that filled the body of the fly were specifically different from those of other species.

He finds that *Peronospora Bulbocapni* is distinct from *P. Corydalis* with which it has been frequently classified, and he finds also that the species of *Peronospora* on *Saxifraga granulata* differs from the form found on *Chrysosplenium* and merits specific rank. He names it *P. Saxifragæ*. The conidia are larger and somewhat different in form from those of *P. Chrysosplenii*.

**Spore-Development in Aphanomyces.†**—W. Rothert finds that the formation of zoospores begins with a layer of protoplasm deposited on the wall of the zoosporangium something like a thickened ring. Vacuoles are subsequently formed in these plasma masses, at a still later stage the individual spores are separated off. He describes in detail all the different stages in the maturing and escape of the zoospores.

**Cœnomycetes g. et sp. n.‡**—Const. von Deckenbach describes this fungus as having zoosporangia which would indicate its connection with the Phycomycetes, but it has also septate mycelium which places it nearer the higher forms. He therefore proposes a new class of fungi the Cœnomycetes, to contain such forms. He takes occasion to examine the relationships of the different groups. *Cœnomycetes* is parasitic on *Calothrix confervicola*.

**New England Choanephora.§**—This genus was found in India and described by Cunningham. It forms zygospores and sporangia which

\* Hedwigia, xlii. (1903) Beibl. pp. 100-4.

† Flora, xcii. (1903) pp. 293-301 (7 figs.).

‡ Tom. cit., pp. 253-83 (2 pls.). § Rhodora, v. (1903) pp. 97-102 (2 figs.).

place it close to the Mucors, and it also bears heads of conidia something similar to those of *Rhopalomyces* or *Ædocephalum*. The writer found his species growing on decaying squashes, and subsequently he cultivated it from a dying flower of *Hibiscus* in Florida. It does considerable injury to squashes, spreading from the dying flower to the growing fruit. The same fungus was recorded in 1875 by Berkeley and Ravenel from Lower Carolina, as *Rhopalomyces Cucurbitarum*. It is now proved to be identical with *Choanephora americana* found recently by Alfred Moeller in Brazil. Thaxter does not hold that this genus forms, as Cunningham supposed, a stepping-stone between the Zygomycetes and the Oomycetes. There is no indication of heterogamy in the sexual spores. Zygosporangia have only been seen in the species from India.

**Fertilisation in Sclerospora.\***—F. L. Stevens finds 40 to 50 nuclei in each oogonium; they are relatively large and fewer in comparison with the size of the oogonium (45–50  $\mu$  in diameter) than usual in Peronosporales. As in *Albugo* the nuclei in the young oogonium rapidly enlarge and pass into the spirem condition; when metaphase is reached they are arranged in an approximate circle round the region that is to become the oosphere, recalling the arrangement of *Albugo candida*. As in that species one nucleus remains behind with the cœnocentrum. During the completion of the mitosis the ooplasm and periplasm become clearly differentiated, and there is a withdrawal of cytoplasm from the periphery of the oogonium as in *A. candida* and *Peronospora*. There is throughout an unthickened region in the oogonial wall contiguous to the antheridium. In history and structure the cœnocentrum agrees well with that of *Albugo Bliti*, with the exception that the central globule has not been demonstrated.

The antheridium is usually very small and is closely appressed to the oogonium; the antheridial nuclei enlarge simultaneously with those of the oogonium and undergo mitosis. No receptive papilla was seen. Communication occurs by the bulging and eventual rupturing of the oogonial wall at this point of contact. The antheridial tube penetrates the oosphere, discharging its contents before it reaches the centre. The male pronucleus is slightly smaller than the female, with which it was seen to fuse.

The general bearing of the cytological evidence emphasises the affinity of *Sclerospora* to the Peronosporaceæ rather than to the Albuginaceæ, and indicates a specialised rather than a primitive character.

**Oogenesis in Saprolegnia.†**—B. M. Davis has studied the formation of eggs and asexual spores in *Saprolegnia mixta*, an apogamous species. The resting nucleus has a loose linin network and a nucleolus, and shows essentially the structure of the nucleus of the higher plants. There is one mitosis in the oogonium, the spindle being intranuclear. The daughter nuclei are much smaller than their parents and some show signs of degeneration, the membranes becoming indistinct and the

\* Bot. Gazette, xxxiv. (1902) pp. 420–5 (1 pl.).

† Op. cit., xxxv. (1903) pp. 233–49, 320–59 (2½ pls.).

contents finally lie as granules in clear vacuole-like areas. The eggs are formed during this process of degeneration. The protoplasm is arranged around a large central vacuole; the ooplasm collects round several centres each of which will become an egg-origin. The differentiation of the egg-origins takes place around a deeply stained protoplasmic body, the cœnocentrum which is formed *de novo*, one for each egg-origin. The cœnocentrum becomes less distinct during the ripening of the egg and finally disappears; it is probably the morphological expression of dynamic activities in the oogonium when the egg-origins are differentiated, and is a sort of focal point of the metabolic processes peculiar to oogenesis. They exert a chemotactic influence on any nuclei in its immediate vicinity. Generally one nucleus comes to lie very close to the cœnocentrum; this favoured nucleus increases in size when all other nuclei in the egg-origins and young eggs are degenerating. Sometimes two or even three nuclei may lie sufficiently near the cœnocentrum to be saved from degeneration, and such eggs become bi- or trinucleate. As the eggs mature the favoured nucleus increases, becoming many times larger than at the period following the mitosis. The other nuclei have generally become quite disorganised, but sometimes traces remain as granules scattered in the cytoplasm. The author's results show that binucleate eggs in the Saprolegniæ need have no relation to the problem of sexuality. His work on the sporogenesis gives a general confirmation of the accounts of Rothert, Hartog, and Humphrey. The uninucleate spore-origins are differentiated by clefts that push them away from the central vacuole of the sporangium to the periphery. When the clefts reach the cell-wall the turgor of the sporangium is relieved by the escape of water, and spore-origins run together, but soon draw apart again and become rounded off as zoospores. There seem to be no cytoplasmic centres in the sporangium comparable to the cœnocentra.

**Cultivation of Truffles.\*** — Louis Matruchot has succeeded in germinating the spores of *Tuber melanosporum* and of *T. uncinatum*. He sowed them on sterilised slices of potato to which was added a nutritive medium, and obtained in both instances a copious white mycelium, which in a short time became brown, similar to the mycelium that is to be found in truffle beds, and otherwise identical with it in appearance. The author considers that the possibility of easily producing this mycelium may have an important bearing on the culture of truffles. The mycelium formed sclerotium-like bodies in the culture-tubes which were probably undeveloped truffles.

Raphael Dubois † reports that in order to induce the germination of truffle-spores, he infected the living rhizome. A plentiful mycelium was produced which he has kept growing and finally buried at the foot of some oaks. Final results are not yet attained.

Louis Matruchot ‡ furnishes a description of the different mycelia obtained by him from the culture of truffle spores. He has not obtained any conidial forms.

Emile Boulanger † records some curious observations on the germination of truffle-spores. He worked with *Tuber melanosporum*.

\* Comptes Rendus, cxxxvi. (1903) pp. 1099-1101.

† Tom. cit., p. 1291.

‡ Tom. cit., pp. 1337-38.

§ 'Germination de l'ascospore de la Truffe,' Paris, 1903, 20 pp. (2 pls.).

**Peziza vesiculosa.\***—L. Petri describes an abnormal form of this fungus. A crowded mass grew on the plaster of an old wall so packed together that the separate individuals could hardly be distinguished, and the hymenium of each specimen was contorted into a series of convolutions something like a *Gyromitra*, thus adding largely to the hymenial surface.

**Potato Disease.†**—V. Peglion examined some tubers that had been dried up and killed. The lower part of the stalk and the underground rhizome were invested with white mycelium, which later formed sclerotia, determined by the author to be identical with those of *Sclerotinia Libertiana*. The disease, which occurred in North Italy, has not done extensive damage as yet.

**Destruction of Seeds by Fungi.‡**—Vittorio Peglion noticed that some seeds of trefoil and lucerne were dark in colour and became covered with fungal growth when kept in moist conditions. *Alternaria tenuis* developed first on the seeds, and later *Pleospora Alternarie*. He examined the seeds in their resting condition and found that the tissues were already invaded by fungi and therefore valueless for agricultural purposes.

**Disease of the Alder.§**—Paul Nypels describes a wound parasite, *Valsa oxytoma*, which attacks and destroys the branches of the tree. The first indication of the presence of the fungus is a yellowing of the epidermis. The bark then gradually turns brown and dies, and the fruits of the fungus burst through as little black specks. From the bark the parasite penetrates to the wood and spreads to other parts of the branch.

**Epiplasm of Ascomycetes.||**—A. Guilliermond has studied spore-formation in a number of forms of Ascomycetes and Hyphomycetes, and more especially *Ascobolus marginatus*, his aim being to gain further knowledge as to the presence and function of the metachromatic corpuscles. In *A. marginatus* he found in the mother-cell of the ascus a dense cytoplasm occupying the centre in which lies the nucleus. The two poles are occupied by vacuoles which contain the corpuscles forming the epiplasm of the cell. He describes in detail the formation of the spores, during which the metachromatic corpuscles increase at the expense of the cytoplasm which surrounds the vacuoles, and take various forms. As the spores mature they gradually absorb the epiplasm. Different results were found in other forms examined; more or fewer of the corpuscles being present in the epiplasm, in some cases none were found. The author considers them to be reserve-bodies.

**Sexuality of the Ascomycetes.¶**—P. A. Dangeard publishes a note on the formation of the ascus in *Monascus*. He finds that there is no nuclear fusion except that which takes place on the origin of the ascus.

\* Nuov. Giorn. Bot. Ital., x. (1903) pp. 271-2.

† Italia Agricola, xxxiv. (1902) pp. 396-98 (1 pl.). See also Centralbl. Bakt., x. (1903) pp. 290-91.

‡ Atti Reale Accad. Lincei, xii. (1903) pp. 270-4.

§ Soc. Belge Microsc., xxv. pp. 95-105. See also Centralbl. Bakt., x. pp. 266-67.

|| Ann. Mycol., i. (1903) pp. 201-15 (2 pls.).

¶ Comptes Rendus, cxxxvi. (1903) pp. 1281-3.

The nuclei both of the antheridium and trichogyne, after anastomosis of these two cells, degenerate without fusion. The antheridium occasionally gives rise to a chlamydo-spore or to a perithecium.

In a further account\* of *Pyronema confluens* the writer affirms the same conclusion, that though antheridium and trichogyne are present and anastomose they are functionless, and that the ascogenous cell is cut off from the trichogyne and produces the ascus-bearing branches without any nuclear fusion.

**Infection-Powers of Ascospores in Erysiphaceæ.**†—E. S. Salmon describes his experiments to test Neger's theory that though the conidial stage of *Erysiphe Graminis* represented a biologic form confined to one host, the ascospores would prove to be the connecting link between different host-plant species. He used in each case the perithecia of the fungus from barley. The leaves covered by the fungus had been kept dry during the winter. On being placed in suitable conditions the ascospores developed, the perithecia burst open and they were ejected on to the glass cover of the Petri dish forming the moist chamber. From this material Salmon infected seedling plants of barley, oats, wheat, and rye. Repeated experiments resulted in the production of a plentiful growth of the *Oidium* on the barley plants. In no case, we gather, did any of the other plants take the infection.

In a further communication‡ he records the results of a number of experiments on plants of several species of *Hordeum*, and proves conclusively that in the case of this fungus "biologic forms" are present in the ascigerous stage as well as in the conidial forms. Many interesting observations on the germination of spores are made and on infection methods.

The same author§ finally sums up the results of his study of the specialisation of parasitism in the Erysiphaceæ, and the extent to which the spores of the fungus will infect different hosts. He proves satisfactorily the existence of biologic forms in the species; and gives tables of the time, temperature, &c., of the different infections.

Em. Marchal|| has conducted experiments on similar lines and arrives at very similar conclusions. He infected the same host-plants with the conidia and with the ascospores, and the results corresponded in each case, proving the fixed character of the biologic forms.

**Influence of Substratum on Germination of Spores of Penicillium.**¶—P. Lesage experimenting with cultures of *Penicillium glaucum* on drops of gelatin or nutritive jelly, concludes that the germination of the spores is influenced by the substratum; that the substratum formed by the jelly of old cultures is unfavourable to the germination of new spores; and that exposure to dry air for some time modifies such substratum so that it is no longer unfavourable to the germination. The nature of the modification is subject for future investigation.

\* Tom. cit., pp. 1335-36.

† Journ. Bot., xli. (1903) pp. 159-65.

‡ Tom. cit., pp. 204-212.

§ Beih. Bot. Centralbl., xiv. (1903) pp. 261-315 (1 pl. and 6 figs.).

|| Comptes Rendus, cxxxvi. (1903) pp. 1280-81.

¶ Trav. Scient. Univ. Rennes, i. (1902) pp. 171-4.

**Observations on Gymnoasceæ.\***—E. Dale has grown and watched the development of three species of *Gymnoascus*. She gives a historical account of this and neighbouring genera, and records the results of the various cultures made. She finds that in *G. Reesii* the fructifications arise on aërial tufts of hyphæ. The origin and growth of the sexual cells is followed throughout. They are at first uni-nucleated, but at the time of fusion they contain large numbers of nuclei. These pass over into the ascogenous cell, and from it arise the fertile branches, the tips of which swell out to form the asci. No conidia were formed in this species. In *G. setosus* the ascospore on germination puts out one or two germ-tubes which branch and immediately form conidia by budding. No other form of fructification was observed in the artificial cultures. *G. candidus* also germinated readily and fruits were produced as well as oidia. The writer discusses the connection between *Gymnoascus* and allied genera.

**Cytology of Yeast.†**—A. Guilliermond winds up his account of the nuclei of yeasts by a more definite account of the metachromatic corpuscles. He mentions the different workers who have published any account of them with special reference to Marx and Worthe's theories as to their significance in bacteria. He details their reaction to stains and to various chemical reagents. In discussing their function, he rather inclines to consider them reserve-bodies. A full bibliography of the series of papers is appended, and a description of the plates that appeared with the previous chapters.

**Observations on the Vitality of Yeast.‡**—H. Will furnishes further data as to the preservation of yeast in the charcoal and asbestos used in connection with brewing. They were again tested after a lapse of 16 years and 3 months. The charcoal had been invaded by moisture and was spoilt for experiment. From the asbestos only wild yeasts were developed. The writer discusses the influence of moisture and temperature on the preservation of the yeast plant.

**Yeast Forms, &c.§**—W. Henneberg writes on the two yeasts, Race II. and XII. that are much used in distilleries. He notes the distinguishing features of the two on the culture plates: the first growing in smooth slightly convex groups; the other in coral formation, hollow at the centre. The distinctions between the two appear in solutions, and they are also easily recognised under the Microscope.

M. Hartman|| found *Torula colliculosa* sp. n. among dried yeast from Java. It formed in cultures small elevations composed of larger cells than the rest of the growth. These large cells had the power of causing fermentation of maltose. Young cultures that had not yet produced these large cells could not induce such fermentation. The

\* Ann. Bot., xvii. (1903) pp. 570-96 (2 pls.).

† Rev. Gén. Bot., xv. (1903) pp. 166-85.

‡ Zeitschr. Gesell. Brauerw., xxvi. (1903) pp. 57-8. See also Centralbl. Bakt., x. (1903) p. 251.

§ Zeitschr. Spiritusindust., No. 9 (1903) pl. i. See also Centralbl. Bakt., x. (1903) pp. 353-4.

|| Wöchenschr. Brauer., xx. No. 11, pp. 113-14. See also Centralbl. Bakt., x. (1903) pp. 463-4.



author records the results of the various experiments with the *Torula* fungus.

Eduard Buchner\* and others have conducted a research on zymase fermentations and pay special attention to the biological side of the fermentation problem in connection with the cell-contents of yeast.

P. Mazé † has devoted special attention to the forms of yeast that are capable of acting on lactose and which are quite different from the ordinary species of *Saccharomyces*. He finds them most easily in soft cheese, and he adds a list of the different kinds of cheese from which he has isolated these special yeasts. He gives a detailed account of the growing conditions of the cells and of the effects produced in different culture media. The yeasts of lactose he finds have but little activity as alcoholic ferments and are slow in action.

**Research on Klein's Yeast. ‡**—E. Cohn gives us the results of further work on this yeast that has proved fatal to small animals, and has caused tumours, &c. on the larger animals. He describes the different reactions of the cell and the nucleus to stains. He notes specially the presence of the capsule as a ring round the yeast cell, a peculiarity of pathogenic yeasts. The changes induced in the tissues of the animal by the presence of the yeast and the development of the injury caused by it are described. Experiments were also made on immunising the animals, and the results are recorded, but further research is required on this question.

**Action of Yeast on Albumen. §**—Th. Bokorny describes in detail the different processes and cultures followed by him in his study of the proteolysis of albuminous substances by yeast; noting specially the odour and taste of the substances produced, with the commercial bearing of the results obtained.

**Structure of Botrytis cinerea. ||**—In addition to the ascospore stage J. Beauverie and A. Guilliermond distinguish three distinct conditions of this fungus which they have studied by means of cultures on various substances. The first form described is the conidial stage, which occurs so frequently in nature on all kinds of decaying vegetation. The writers describe the development of the mycelium and note the presence of metachromatic corpuscles, especially in the spore-producing filaments. The spores contain one nucleus and a large vacuole. The occurrence of oil-globules and glycogen as affected by the different culture media, is also described.

A second intermediate form is distinguished by the proliferation of the spores on the sporophores. It is occasionally met with in nature and occurs frequently in temperate conservatories. The same phenomena of mycelial development were observed as in the typical *B. cinerea*.

Still another condition is characterised as the web form (*toile*). It is entirely sterile and spreads over the surface of the soil in forcing-

\* Centralbl. Bakt., x. (1903) pp. 464-8.

† Ann. Inst. Pasteur, xvii. pp. 11-30.

‡ Centralbl. Bakt., 1<sup>re</sup> Abt., xxxiii. (1903) pp. 688-96 (2 pls.).

§ Chem. Zeit., 1903, No. 1. See also Centralbl. Bakt., x. (1903) pp. 285-8.

|| Centralbl. Bakt., x. (1903) pp. 275-81 (14 figs.), and pp. 311-20 (14 figs.).

houses, destroying the young plants. The form is fixed and under no condition reverts to the fertile stage. Glycogen was found in great abundance in the filaments composing the web. Metachromatic corpuscles were absent, though they were developed by placing the hyphæ in distilled water. The presence of these bodies in bacteria has been associated with the pathogenic character of the organisms, but this view does not correspond with the author's observations on the "web" fungus. Only when it is non-pathogenic, as in distilled water, are the corpuscles developed. Protoplasmic communication between the cells, and the anastomosing of the filaments are also described. The papers are illustrated by many figures in the text.

**Botrytis citricola** sp. n.\* — Ugo Brizi publishes a preliminary paper on a disease of oranges and lemons. Reddish spots make their appearance on immature fruits, small at first and then gradually increasing till the whole fruit is attacked, its sap destroyed, and a darkened mummified mass is left. Brizi found the mycelium of a fungus, and by careful culture methods induced the growth of the conidiophores of a *Botrytis* which he found was a new species and named it *B. citricola*. He got no other form of the fungus and he concluded that the mycelium hibernated in the mummified fruits. The fruits attacked had all a characteristic odour.

**Development of Ramularia æquivoca.**† — Pietro Voglino has followed the growth of this fungus which appeared on the under side of the leaves of *Ranunculus acris* along with *Erysiphe communis*. He kept the leaves for some time and there grew on the infected ones, perithecia of *Stigmatea Ranunculi* Fries. By repeated, persistent cultures he developed the same perithecia from the spores of *Ramularia æquivoca*, thus proving the latter to be the conidial form of the higher fungus. Voglino demonstrates the similarity between *R. æquivoca* (Ces.) Sacc. and *R. gibba* Fuck. The latter must be considered a synonym of the older species.

**Rusts of Cereals.**‡ — Em. Marchal writes a lengthy report on *Puccinia Graminis*, *P. triticina*, *P. dispersa*, *P. glumarum*, *P. simplex*, and *P. coronifera*, the members of the rust family that attack one or other of the cereal crops. Inquiries have been made throughout the provinces as to the occurrence of these fungi, and the information elicited is tabulated and printed. Marchal discusses also the various factors that influence the spread of the rusts, such as weather, soil, manure, &c., and advises as to the best means of combating the disease.

**Experiments with Pucciniæ.**§ — Ernst Jacky has taken advantage of a supply of the chrysanthemum Uredine to make infection experiments on *C. chinense* and *C. indicum*. A *Puccinia* on former plants had been named by P. Hennings *P. Chrysanthemi chinensis*, but Jacky finds that it is identical morphologically and biologically with an earlier species *P. Chrysanthemi* Roze. It occurs in Japan, Europe, and North America.

\* Atti R. Accad. Lincei, xii. (1903) pp. 318-24.

† Malpighia, xvii. (1903) pp. 16-22 (4 figs.).

‡ 'Recherches sur la Rouille des Céréales,' Bruxelles, 1903, 40 pp.

§ Centralbl. Bakt., x. (1903) pp. 369-81 (8 figs.).

The uredospores of this species vary to a great extent, and are constantly two-celled. Transition forms between the one-celled and two-celled spores are also frequently found. The teleutospores have been found as yet only on plants from Japan. The author rewrites the diagnosis of the species.

W. Bandi \* completes his accounts of experiments with *Phragmidium subcorticium* and *Puccinia Caricis-Montana*. In the first he has determined two biological forms, on different species of *Rosa*. In the sedge *Puccinia* he finds there are also two forms that produce their teleutospores on *Carex montana*; but while one forms its æcidia on *Centaurea montana*, the alternate host of the other is *Cent. Scabiosa*.

**Puccinia dispersa and its adaptive Parasitism.** †—H. Marshall Ward discusses the persistence of the Uredospores. He found that some spores germinated after sixty-one days. He records many interesting observations as to the influence of temperature, light, &c., in aiding or retarding germination. He has found in the course of the experiments that though the uredospores from one species of *Bromus* will infect only the closely allied species, there are yet what he terms "bridging species" or intermediary species between the different groups that carry over the fungus from one section of the genus to another. Tables are furnished of the different experiments.

In another communication the author ‡ gives a detailed study of the germination, infection, and growth of the mycelium of the Uredo in the tissue of grasses. He deals with the behaviour of the nuclei, vacuoles, septa, branches, haustoria, and other details of the hyphæ up to the commencement of spore-formation. Special attention was paid throughout to Eriksson's *mycoplasma* hypothesis. Marshall Ward refutes this theory; he finds that Eriksson's *corpuscles spéciaux* are the cut-off haustoria of the fungus, and are not the outgrowths of latent germs in the cell.

**Rusts of Special Natural Orders.** §—J. Ivar Lindroth has published new diagnoses and a general revision of the Uredineæ that are parasitic on Umbelliferæ. He divides the *Pucciniæ* into the following groups:—

1. Reticulatæ. The epispore of the teleutospores has a netlike structure.

2. Psorodermæ. The teleutospores are covered more or less thickly with warts.

3. Bullatæ. The teleutospores are smooth, the membrane of the uredospores is thickened at the apex.

4. This group includes a number of interesting forms, the teleutospore sori of which are a long time covered by the epidermis of the host, the spores have a thickened apex and a coloured persistent stalk. Only a few of the Umbelliferæ rusts show these peculiarities.

5. In the last group there are only 3 species; the spores themselves resemble those of group 5. They are all *Lepto-Pucciniæ*.

\* Hedwigia, xlii. (1903) pp. 119-52. † Ann. Mycol., i. (1903) pp. 132-51.

‡ Proc. Roy. Soc., lxxi. (1903) pp. 353-4. See also Proc. Cambr. Phil. Soc., xii. (1903) p. 84.

§ Act. Soc. Fann. et Fl. Fenn., xxii. No. 1 (1902) 223 pp. (1 pl.). Meddel. Stockh. Högsk. Bot. Inst., v. (1902).

Lindroth describes also the *Uromyces* of the same natural order and the isolated spore forms that have been found. Only one *Cæoma* is recorded and that from S. America. He discusses at some length his reasons for the above grouping and the biological questions raised in connection with the work. He gives a full bibliography with an index of host plants and parasites.

In another communication Lindroth\* describes some Uredineæ that are found on species of Compositæ. He gives an account of several *Puccinia*, *Uromyces Mulgedii* and *Æcidium Lactucinum*. He also writes at length on *Puccinia Kamtschatkæ* Anders. The fungus was first detected on roses at Simla by Barclay, and named by him *P. Rosæ*, but as that name was already appropriated for another species the latter name must be adopted.

P. and H. Sydow † have issued a third part of their monograph of Uredineæ. They are still engaged on the genus *Puccinia*, and they deal with a considerable number of natural orders of host plants including the remaining forms on Umbelliferae and the species occurring on Rosaceæ, Malvaceæ, Violaceæ, Cruciferae, Polygonaceæ, &c. Some of the species are published for the first time.

**Bornetina Corium.** ‡—L. Mangin and P. Viala give further details on the structure and growth of this fungus which causes the root disease of the vine known as phthiriose of the vine. They conclude that its affinities place it between the Ustilagineæ and the Basidiomycetes, and that it represents a new type, that of the Bornetineæ.

The authors § have grown the fungus in a variety of culture media and find that it varies very considerably: not only the mycelium, but the spores are affected by the substances on which they have grown.

**Uromyces of Lupins.** ||—P. Dietel has examined the different forms of *Uromyces* found on species of Lupin, and has classified them in systematic order. He has renamed a species from America, designated as identical with *Uromyces Genistæ-tinctoriæ*. He considers it to be distinct and calls it *U. occidentalis*. Another American species *U. tomentellus* he places under *U. Lupinus* Berk. and Curt.

**Nomenclature of Uredineæ.** ¶—P. Magnus discusses the names given in Von Martens' *Prodromus Floræ Mosquensis* to various rusts found on species of Compositæ.

**Tilletia abscondita** Syd. sp. n.\*\*—This fungus, described by H. and P. Sydow, occurs in the fruit capsules of *Anthoceros*. Similar spores had been noted in the sporogonia of *Sphagnum*, and had been discovered after considerable research to be fungus spores. The species found in *Anthoceros* is very similar to that of the *Sphagnum*, but the spores are much larger and have a thick episore. No one has succeeded as yet in germinating the fungus spores found in mosses.

\* Tom. cit., xx. No. 9 (1901) 29 pp. (1 pl.).

† Monographia Uredinearum, i. Fasc. iii. pp. 385-592 (10 pls.).

‡ Comptes Rendus, cxxxvi. (1903) pp. 1699-701.

§ Tom. cit., cxxxvii. (1903) pp. 139-41.

|| Hedwigia, xlii. (1903) Beibl., pp. 75-99.

¶ Oest. bot. Zeitschr., lii. (1902) pp. 428-32, and 490-2. See also Centralbl. Bakl., x. (1903) p. 265-6.

\*\* Ann. Mycol., i. (1903) pp. 174-6.

**Fungi hypogæi.\***—F. Bucholtz gives a morphological and systematic account of these fungi, 45 species of which have been recorded in Russia, one genus and five species being new to science. The writer takes up both the Ascomycetous and Basidiomycetous groups and gives the development of certain forms in each. A list of the Russian species is given and a bibliography.

**Persistence of Fungal Parasites in altered Conditions of the Host Plants.†**—P. Hennings has made notes on a series of plants affected by Ustilagineæ and Uredineæ. They were transplanted and kept under observation and it was found in several instances that the disease disappeared in a few years. The writer makes further observations on the conditions of growth of the host as affecting the recurrence of the parasite.

**Chemical Action of Growing Fungi.‡**—O. Emmerling and E. Abderhalden criticise Löw's results as to the production of proto-catechuic acid by the growth of fungi on quinic acid. They conclude that some Schizomycetes must also have taken part in the various reactions. They isolated one of these which they named *Micrococcus chinicus*. They found this organism also in potassium citrate that had been inoculated with foul meat solution. The authors are still engaged on the research.

O. Emmerling § also gives the results obtained by growing *Aspergillus niger* on various substances. Oxalic acid was formed most frequently as ammonium oxalate. The writer gives a table of percentages of the oxalate produced in the different nutritive media, and also a list of substances in which no oxalic acid was formed by the growth of the fungus.

**Culture of Sterigmatocystis nigra.||**—M. Molliard and H. Coupin have grown this fungus in Raulin's solution but without potassium. They find that in these conditions the spores are produced with difficulty, the conidial heads proliferate; forms corresponding to *Aspergillus* and *Penicillium* are also produced, the conidia are smaller and they germinate on the heads and form chlamydo-spores.

**Notes on Various Fungi.¶**—G. Arcangeli calls attention to the alteration caused by the presence of *Æcidium Rumicis* on two species of *Rumex*. The parts of the leaf affected were coloured red with a yellowish margin. An examination of the tissues showed that the red colouring matter was confined to special cells. He notes other fungi that produce the same effect such as *Exoascus deformans*, *Ovularia obliqua*, &c., and discusses the probable reason for the presence of the pigment. Some other fungi are commented on, and the dimensions are given of a very large specimen of *Boletus edulis*. It reached a height of 33 cm.

**Notes on Nomenclature.\*\***—H. and P. Sydow record the curious instance of a new genus of fungi *Didymostilbe* being published by two

\* Ann. Mycol., i. (1903) pp. 152-74 (2 pls.).

† Zeitsch. Pflanzenkr., xiii. (1903) pp. 41-5.

‡ Centralbl. Bakt., x. (1903) pp. 337-9.

§ Tom. cit., pp. 273-5.

¶ Comptes Rendus, cxxxvi. (1903) pp. 1695-6.

¶ Bull. Soc. Ital., 1903, pp. 57-61.

\*\* Ann. Mycol., i. (1903) pp. 176-8.

authors within a few days of each other. The genera are identical. Another case is the publication of *Microdiplodia* in 1901 in Rabenhorst's *Krypt. Flora, Fung. Imperfect.* The same genus, under the same name, was published by F. Tassi in 1902. The authors give also a list of recently described new fungi which are identical with already well-established species.

**Canker of Fruit Trees.\***—Joseph Brzezinski has devoted much time and attention to the disease known as canker, and almost universally considered to be due to the ravages of a fungus *Nectria ditissima*. His first experiments were conducted with a view to studying the effects of the fungus, and, to induce canker, he infected young apple trees with the spores of *Nectria*, with continued negative results. A closer examination of the diseased parts of the trees revealed the constant presence of *Bacteria* in the tissues. Cultures were made of these and healthy trees inoculated, with the result that canker was easily produced by the introduction of the microbes. The author gives a detailed account of the organism, which he designates *Bacterium Mali*, and describes its action on the tissues of the host plant. The wood parenchyma succumbs easily to the action of the bacterium while the cells of the medullary rays are more resistant. This is explained by the greater vitality of these cells.

General bacteriosis of the tree is a malady to which he also calls attention, and which results in the death of the tree. Bacteria were found in profusion in branches suffering from the malady.

Nodosities on the roots, also a serious danger to the trees, were examined and experimented on, and were found to be due to *Bacterium mali*. Chlorosis of plants he also traces to bacterial action.

On the pear he found cankers similarly produced. The *Bacterium* was indistinguishable from that in the apple, but in artificial cultures it formed yellow coloured colonies while those of the apple *Bacterium* were always greyish-white. It was considered therefore to be another species, and named *B. Pyri*. Still another, *B. Coryli*, was found to cause canker in nut-trees. The author concludes that bacterial disease of trees is as common as it is deadly. Gummosis, also due to bacteria, is accompanied by a discharge of gum. There are thus two very different series of vegetable pathogenic bacteria at work, those that form gum, and those, as in the case of canker and chlorosis, that do not cause any exudation.

**Fungicides.†**—R. J. Moss has tested the effect of various copper solutions on potato-disease. He recommends for spraying the affected plants, Burgundy mixture, a solution of copper sulphate with ordinary crystallised sodium carbonate in the proportion of three parts of soda to two of copper sulphate. The deposit produced on the leaves by this mixture is very adhesive and resists the action of rain, and is thus more effective as a remedy for potato-blight.

T. Johnson‡ gives the results of experiments on smutted grain. The object in this case is to destroy any fungus spore adhering to the

\* Bull. intern. Acad. Sci. Cracov., 1903, pp. 95-142 (7 pls.).

† Econ. Proc. Roy. Dubl. Soc., 1. (1902) pp. 109-18.

‡ Tom. cit., pp. 119-31.

seed corn. He rather deprecates the hot-water method. It is cheap and effective, but mistakes are easily made by allowing the temperature of the water to be just too high or too low, or by leaving the grains too long in the hot water. For simplicity he recommends a solution of sodium sulphide called "sar," in which the corn should be immersed 24 hours. The results obtained from this method of killing the spores were most satisfactory.

**Fungus Diseases.\***—J. Ferraris gives an account of a disease of rice caused by *Piricularia Oryzae*. The plant is attacked at the upper node of the stalk and a brown patch is caused by the fungus invading and destroying the cells. It penetrates the vessels and from them it invades the tissues above and below the node.

A description † is published by the Board of Agriculture of *Botrytis cinerea* as it affects various conifers. The results of infection experiments are given and advice as to the best method of dealing with the disease.

J. Ritzema Bos ‡ describes the diseased condition of *Narcissus* leaves that were attacked by *Helminthosporium gracile*. The disease is known in Holland as "Brand" or "burning" of the leaves.

Dr. Ewert § gives an account of the occurrence of *Cronartium ribicolum* on various species of *Ribes*.

J. Ritzema Bos || publishes a review of the work done during the year in the phytopathological laboratory at Amsterdam. A large number of harmful parasites are dealt with. A myxomycete *Physarium bivalve* is recorded as causing the suffocation of plants of *Phaseolus* in a green-house. A bacterial disease of turnips caused by *Pseudomonas campestris* was found in North Holland, but was less virulent than in 1900. Work on plant diseases was also done by G. Staes, C. J. J. van Hall, and A. Ide.

**Phytopathology.¶**—In connection with the Belgian Agricultural Institute, Em. Marchal publishes a series of observations on the plant diseases that have caused trouble during the course of the year on cultivated plants. He signalises as new to the country *Rhizoctonia* on *Asparagus*; a black rot of beans due to *Fusarium*, and a *Coryneum* on the leaves of the peach.

G. Delacroix \*\* describes the conidial form of black rot of the vine (*Guignardia Bidwellii*), a canker of apples caused by *Sphaeropsis malorum*, a monstrous formation of *Claviceps purpurea*, spots on guavas caused by *Glaeosporium Psidii* sp. n., and adds a note on the occurrence of *Puccinia malvacearum* in France.

**Wild Plants as Nurseries of Plant-Disease.††**—A. D. Cotton draws attention to the danger of allowing weeds to grow in gardens, as many

\* Malpighia, xvii. (1903) pp. 129-59 (2 pls.).

† Journ. Board. Agric., x. (1903) pp. 17-21 (1 pl.).

‡ Zeitschr. Pflanzenkr., xiii. (1903) pp. 87-92. § Tom. cit., pp. 92-3.

|| Tijdschr. over Plantenziekten, viii., 202 pp. and 5 pls. See also Centralbl. Bakt., x. (1903) pp. 390-7.

¶ Bull. Servi. Phytopath. Inst. Agr. de l'État, No. 8 (1903) 14 pp.

\*\* Bull. Soc. Mycol. France, xix. (1903) pp. 128-45 (6 figs.).

†† Journ. Roy. Hort. Soc., xxvii. (1903) pp. 935-42.

of them afford a home for diseases caused by parasitic fungi. A number of the common weeds are mentioned arranged in their natural orders and descriptions, or references to descriptions of the diseases to which they are subject are given.

**Fungi Polonici.\***—J. Bresadola publishes a continuation of the list of fungi from Poland. He states the time of year when the specimens were gathered, but he does not give particular localities. Under the genus *Kneiffia* he places the species that have been classified as *Peniophora*. He considers that *Kneiffia* as based on the type *K. setigera* is indistinguishable from the genus *Peniophora*, and that the character of one-spored basidia breaks down even in the type species, where the basidia are frequently four-spored. He adds a number of new forms to the genus. Many new species belonging to other genera are also described, and a plate is published with figures of three new species, *Eichleriella incarnata*, *E. leucophaea*, and *Platyglwa Miedzyrzecensis*. A few *Myceozoa* are recorded and one new Schizomycete, *Spirillum roseum* sp. n.

**American Fungi.†**—W. A. Murrill continues his study of the Polyporaceæ and deals in the present paper with the genus *Fomes* as understood by Gillet. He gives a synopsis and description of eleven American species; two of these are new to science and other two are exclusively American. To a note on *Fomes Laricis*, he records its appearance on pine and spruce. In Europe its growth is confined to the larch.

In another paper ‡ he publishes a historical review of all the genera of this group.

The same author § proposes a new family of Basidiomycetes, Xylophagaceæ, to include all gelatinous forms with a porose hymenium. These are subdivided into three families, Favolaschieæ (*Favolaschia*), Xylophageæ (*Xylophagus*), and Glæoporeæ (*Glæoporus*).

F. S. Earle || publishes a key to the North American species of *Stropharia*. There are eleven species of the genus dealt with.

The same author ¶ furnishes a new key to the genus *Lentinus*. He recognises the following sections:—Criniti, including Pulverulenti; Lepidei, Cochleati, Cornucopioides, Plenroti, and Resupinati. The species included in the two latter sections, he thinks belong more properly to the genera *Pleurotus* and *Panus*.

C. G. Lloyd \*\* continues his issue of mycological notes. He describes the genera and species of the Bovistæ, Tylostomeæ, and some of the Podaxineæ with notes on other fungi.

W. C. Blasdale †† writes on a rust of snapdragon.

A. P. Morgan ††† describes a new species of *Sirothecium*. Elias J. Durand gives the American species of *Sarcosoma*. J. B. Ellis and W. A. Kellerman §§ describe two new species of *Cercospora*. W. A.

\* Ann. Mycol., i. (1903) pp. 97-131 (1 pl.).

† Bull. Torrey Bot. Club, xxx. (1903) pp. 225-32.

‡ Journ. Mycol., ix. (1903) pp. 87-102. § Torreyia, iii. (1903) p. 7.

|| Tom. cit., pp. 24-5.

¶ Tom. cit., pp. 35, 38, and 58-60.

\*\* Mycol. Notes, Cincinnati, No. 12 (1902) pp. 113-48 (16 pls.).

†† Journ. Mycol., ix. (1903) pp. 81-2.

††† Tom. cit., pp. 82-3, 102-4.

§§ Tom. cit., p. 105 (2 figs.).



Kellerman \* publishes notes on some Uredineæ with results of infection experiments made by him.

**Australian Fungi.**†—P. Hennings describes specimens collected in Queensland, West Australia, and New Zealand by E. Pritzel and L. Diels. A number of new species are recorded and two new genera, *Dielsiella*, one of the Hysteriaceæ, which grows on both sides of fallen leaves. *Pritzeliella*, the other new genus, is a member of the Hyalostilbaceæ, and near akin to *Coremium*. With few exceptions the plants described all belong to the micro-fungi.

D. M'Alpine ‡ publishes two decades of micro-fungi. All of them are additions to the Australian fungus-flora. Eleven new species and twelve different genera are represented. With the exception of one species from New South Wales, they were all collected in Victoria. Full descriptions are given of the new plants.

**New Records of Fungi.**§—T. Vestergren has examined the fungi collected by himself on the island of Oesel in the summer of 1899. He records 290 different species belonging to the Ascomycetes, Sphærospideæ and Hyphomycetes. Many of the species found are new. He gives a detailed account of the Uredineæ.

Otto Japp || contributes a list of fungi to the Cryptogamic flora of the island Röm, two species are new.

E. Barsali ¶ records 154 Hymenomycetes from the neighbourhood of Pisa. For each species he gives the habitat and the name of the collector.

H. Diedecke \*\* publishes a descriptive list of Sphærioidæ from Thuringia. Several species are new to science.

H. and P. Sydow have †† determined a number of fungi, mostly "Fungi imperfecti" from South America, and publish diagnoses of the new species they have found in the various collections. They add a short list of species determined by Saccardo, also from South America.

Eight new species of Uredineæ from Japan are published by P. Hennings.‡‡ One of the species *Uredo Sojae* was found to have *Darluka filum* growing on it.

The same writer §§ gives a long list of fungi from the Government of Moscow. He adds a new species of *Lachnea* and a new *Leptothyrium* to the flora.

H. Rehm ||| gives a first series of *Ascomyceten-Studien*, a descriptive list of 16 species of micro-fungi, nearly all of them new to science.

Ed. Fischer ¶¶ gives a contribution to the knowledge of Swiss

\* Tom. cit., pp. 107-10 (1 pl.).

† Hedwigia, xlii. (1903) Beibl., pp. 73-88 (7 figs.).

‡ Proc. Linn. Soc. New South Wales, xxvii. (1902) pp. 373-9.

§ Hedwigia, xlii. (1903) pp. 76-117 (1 pl.).

|| Schrift. Naturwiss. Ver. Schleswig-Holstein, xii. (1903) Heft 2, 32 pp. See also Ann. Mycol., i. (1903) p. 188.

¶ Bull. Soc. Bot. Ital., 1903, pp. 11-22.

\*\* Hedwigia, xlii. (1903) Beibl., pp. 165-7. †† Tom. cit., pp. 105-6.

‡‡ Tom. cit., pp. 107-8.

§§ Tom. cit., pp. 108-18.

||| Tom. cit., pp. 172-6.

¶¶ Bull. Herb. Boiss., ii. (1902) pp. 950-9. See also Centralbl. Bakt., x. (1903) pp. 289-90.

Uredineæ. He describes the different species of *Uromyces* found on Alpine *Primulæ*. He finds a new species on *Vicia onobrychioides* which he calls *U. valesiacus*. He also gives descriptions of several species of *Æcidium*.

P. Hennings\* finds two new Uredineæ on fruits from South America, a *Uredo* and an *Æcidium*. The latter, he considers, belongs to *Gymnosporangium*.

P. Dietel† gives a list of Uredineæ and Ustilagineæ that are new to the German flora. The work is connected with the report on the flora of Germany.

The same writer‡ has published notes on some North American Uredineæ, with special reference to a species of *Stichospora*.

P. Hennings§ publishes a new species *Boudiera Clausenii* found growing on dung, and adds notes on several other species from the same substratum.

Fr. Bubak|| finds and describes two new Uredineæ on *Mercurialis annua* in Montenegro, and G. B. Traverso¶ records 402 species of Micromycetes from the Province of Modena. The new forms, twelve in number, are illustrated by figures in the text.

José Verissimo d'Almeida and M. de Souza da Camara\*\* contribute a number of micro-fungi found on leaves, fruits, &c. to the flora of Portugal. A number of species are new to science, and one genus, *Sporoctomorpha* a Pyrenomycete found on leaves of Magnolia.

**Systematic Notes on Fungi.**††—N. Patouillard gives detailed accounts of three species of fungi previously recorded from the West Indies. R. Maire and P. A. Saccardo‡‡ supply biological information on several parasitic microfungi. P. A. Saccardo§§ describes a disease of Mandarins caused by *Alternaria tenuis* forma *chalaroides* Sacc. J. B. Traverso||| publishes diagnoses of twelve new species of Italian Micromycetes. H. and P. Sydow¶¶ give an extensive list, a contribution to the fungus flora of the shore-region and of Istria; a few of the species are new. Fr. Bubak\*\*\* redescrines two fungi parasitic on Monocotyledons, *Entyloma Dietelianum* and *Physoderma Debeauvii*; and P. Dietel††† writes on *Zaghouania* from material collected by Sydow in Istria. He describes the form and development of the teleutospores.

Franz v. Hohnel††† corrects some misstatements as to the occurrence of *Ramularia* on plants of Umbelliferae. He describes two new species of the genus.

In another contribution,§§§ he points out the sources of error in determining genera and species of fungi; different stages of growth or

\* Hedwigia, xlii. (1903) Beibl., pp. 188-9.

† Ber. Deutsch. Bot. Ges., xx. (1903) pp. 267-80.

‡ Hedwigia, xlii. (1903) Beibl., pp. 179-81 (2 figs.).

§ Tom. cit., pp. 181-5 (7 figs.).

|| Ber. Deutsch. Bot. Ges., xxi. (1903) pp. 270-5.

¶ Malpighia, xvii. (1903) pp. 163-228.

\*\* Revista Agron., i. (1903) pp. 20-6 (4 pls.), 55-9, and 89-92 (4 pls.). See also Ann Mycol., i. (1903) pp. 185-6. †† Ann. Mycol., i. (1903) pp. 216-7.

‡‡ Tom. cit., pp. 220-4 (2 figs.).

§§ Tom. cit., pp. 225-6.

||| Tom. cit., pp. 228-31.

¶¶ Tom. cit., pp. 232-54.

\*\*\* Tom. cit., pp. 255-6.

††† Tom. cit., pp. 256-7.

††† Hedwigia, xlii. (1903) Beibl., pp. 176-8.

§§§ Tom. cit., pp. 185-8.

different forms of the same species being mistaken for other plants. He describes two new species of *Charonectria* and one of *Diplodina*.

### Lichens.

**Lichens.\***—A. Jatta publishes a first series of the Lichens of the Levier herbarium. They were collected in Southern Asia and in Oceania, many of them are from India. The list includes 86 species, 3 new to science, *Ramalina laciniata*, *Strigula insignis*, and *Leptogium azurellum*.

Some notes on the systematic arrangement of Pyrenocarpous Lichens are published by A. Zahlbrückner.† He holds that the natural arrangement of lichens must follow that of the fungi, giving the great groups of Asco-, Hymeno-, and Gasterolichens. The Ascolichens are subdivided into Pyrenocarpous and Gymnocarpous forms. The writer traces the connection between the *Verrucariaceæ* and other higher families of the group.

M. A. Libert ‡ publishes the lichens of the Ardennes from the *Cryptogamæ Ardennæ*.

Clém. Aigret § has completed a monograph of the *Cladonia* found in Belgium. He gives a historical account of the genus, methods of examination, and analytical tables of the species, which are fully described.

A. Zahlbruckner || furnished a list of lichens in connection with the report on the German Flora; some of the species are new, but in this list only the names and habitat are recorded.

M. Britzelmayr ¶ publishes an account of the lichens collected by him in the Algäuer Alps. Many of them are new to the locality.

**Mycorhiza.\*\***—M. Marcuse has examined a number of plant roots that are inhabited by the endotropic form of Mycorhiza. The presence of the fungus is affected, he finds, by the period of vegetation, and by the age of the roots. The writer touches on various other points of interest. He studied more especially the holosaprophytic Orchidaceæ and such hemisaprophytic plants as *Linum catharticum*, *Polygala amara*, *Pinus sylvestris*, &c.

### Schizophyta.

#### Schizophyceæ.

**Mastigocladus laminosus.††**—A. Löwenstein gives the result of his experiments on this alga in various temperatures. He finds that it flourishes in the Carlsbad spring and can bear a heat of 52° C. The plant was made to grow in a mixture of spring water, Molisch's nutritive solution, and Moldau water at the same high temperature. But it can

\* Malpighia, xvii. (1903) pp. 3-15.

† Verh. K. K. Zool.-bot. Ges. Wien, liii. (1903) pp. 81-2.

‡ Malpighia, xvii. (1903) pp. 229-38.

§ Bull. Soc. Roy. Bot. Belg., xl. (1901) pp. 43-213.

|| Ber. Deutsch. Bot. Ges., xx. (1903) pp. 264-76.

¶ Ber. Naturw. Ver. Schwaben u. Neuburg, xxxv. (1902) pp. 91-105. See also Bot. Centralbl., xxiv. (1903) p. 99.

\*\* Inaug. Diss. Univ. Jena, 1902, 30 pp., 1 double plate. See also Hedwigia, xlii. (1903) Beibl. p. 129.

†† Ber. Deutsch. Bot. Ges., xxi. (1903) pp. 317-23.

also live at a temperature of  $-19.3^{\circ}$ . It is shown that this alga, when removed from this normal habitat and cultivated at an ordinary dwelling-room temperature, gradually loses its power of resisting heat; and this becomes the more marked in proportion to the length of time it is cultivated in cool water.

**Osmotic Properties of Cells of Cyanophyceæ.\***—F. Brand details the results of certain experiments in this direction and sets them under three headings. (1) Reaction to plasmolysing solutions; (2) reaction to pure glycerin, glycerin saturation; (3) "plasmoptyse," the effect of sudden irrigation with water on a cell which has just been deprived of its watery sap by glycerin.

**Petalonema alatum.†**—Daisy S. Hone has examined material of this alga collected from the gravel bed of a quiet stream in Minneapolis, where it formed a dark chestnut-brown stratum. The colour is due to the gelatinous sheaths in which the trichomes are imbedded. The pseudocysts are very variable in size and shape. The heterocysts are solitary and interstitial, somewhat globose or oblong, slightly larger than a normal pseudocyst.

**Water-Bloom.‡**—N. P. B. Nelson has studied the subject of this occurrence in Minnesota and neighbouring States, and finds that it may be formed by seven different species of Cyanophyceæ, namely, *Glaotrichia pisum* Thur., *Cælosphaerium kuetzingianum* Naeg., *Aphanizomenon flos-aquæ* Ralfs, *Clathrocystis aeruginosa* Henfr., *Anabæna circinalis* Rabenh., *A. flos-aquæ* Bréb., and *A. mendotæ* (?) He finds that the presence of one or more of these species in water drunk by cattle often causes fatal results.

**Perforating Algæ.§**—G. Nadson passes in review the principal types of this group of algæ, and expresses the opinion that they play an important part in nature, by facilitating the disintegration of rocks and stones. He believes that *Conchocelis rosea* Batt. is a variety of *Ostreobium Queketti*.

**Anabæna.||**—E. Lemmermann describes a new variety, *marchica*, of *Anabæna cylindrica* Lemm., from Langer See in Brandenburg. It is distinguished from the type of the species by its larger size and the absence of the colourless empty cell-wall surrounding the heterocysts. The differences are shown in the form of a table and a key is given which includes four other species having cylindrical cells, as well as *A. cylindrica* and its new variety.

**Calcareous Pebbles.¶**—C. Powell describes some calcareous pebbles found in Clearwater Lake, Wright county, Minnesota. They were found lying on sand-bars in water from 4 to 10 feet deep, and they range in size from that of a small hickory nut to  $\frac{1}{2}$  in. in diameter. All

\* Ber. Deutsch. Bot. Ges., xxi. (1903) pp. 302-9.

† Minnesota Bot. Studies, iii. (1903) pp. 47-50 (1 pl.).

‡ Tom. cit., pp. 51-6 (1 pl.).

§ Script. Bot. Hort. Univ. Petrop., xviii. See also Nuov. Notar., xiv. (1903) p. 141.

|| Hedwigia, xlii. (1903) Beibl., pp. 168, 9.

¶ Minnesota Bot. Studies, iii. (1903) pp. 75-7 (2 pls.).

of them were more or less hollow and were found to consist of a densely interwoven mass of filaments, principally *Schizothrix fasciculata* Gomont. Others from the banks of the Mississippi contained a species of *Scytonema*.

#### Schizomycetes.

**Bacillus of Epidemic Dysentery.\***—L. Vaillard and Ch. Dopter had the opportunity of observing this disease during the Vincennes epidemic of last year. They were able to isolate by means of agar plate cultures, from the stools of all typical and recent cases, the bacillus first described by Chantemesse and Widal and afterwards by Shiga and others. This bacillus is a short rod 1–3  $\mu$  in length, non-motile, without cilia and not forming spores. It stains with the ordinary anilin dyes but not with Gram. It grows on ordinary media and does not liquefy gelatin. It is distinguishable from *B. coli* by not forming indol, by not acting on sugars with gas formation, and by not coagulating milk, and from *B. typhosus* by the absence of cilia and movement. Cultures of it were agglutinated by the sera, in dilutions of  $\frac{1}{20}$ – $\frac{1}{300}$ , of patients suffering, or having recently suffered, from the disease. This agglutinating power appeared about the end of the first week of the disease. Such sera did not agglutinate *B. typhosus*, but occasionally did *B. coli*. There was no agglutination with the sera of healthy persons or of those affected with tropical (amœbic) dysentery. The authors were able, by subcutaneous injection, to produce experimentally the disease in animals, notably in the cat and dog, and the lesions found appeared identical with those of epidemic dysentery in man. The bacilli were found in great numbers in the lesions of the intestinal tract. The bacillus did not appear to secrete a soluble toxin, and injections of filtered cultures did not produce appreciable effects. If, however, an aqueous maceration of dead cultures was made and allowed to sediment, injections of the supernatant bacilli-free fluid produced effects apparently identical with those produced by injections of living cultures. The authors maintain that the immunisation of animals is possible and practicable from the point of view of serum-therapy.

**Nitrogen-assimilating Bacteria.†**—Ed. v. Freudenreich worked with the aerobic *Azotobacter chroococcum* (Beijerinck) and the anaerobic *Clostridium pastorianum* (Winogradsky), but chiefly with the former. This he describes as cocci with a diameter of 2–5  $\mu$ , elliptical forms however being not uncommon, measuring 2–3  $\mu$  by 3–6  $\mu$ . Three or more refractile granules are to be seen in the cell protoplasm in unstained preparations. At times it seems to be motile. It can be obtained by inoculating with earth a solution containing, in water, .05 p.c. potassium biphosphate and 2 p.c. mannite. In this it grows rapidly and from the pellicle formed on the surface it can be isolated by making a series of surface cultures on agar having a similar composition. It does not grow on potatoes, and bouillon inoculated with it remains sterile, so that this medium may be used as a test of the purity of the

\* Ann. Inst. Pasteur, xvii. No. 7 (1903) pp. 463–91.

† Centralbl. Bakt., 2\* Abt., x. (1903) pp. 514–22.

culture. Good results were obtained by growing it on gypsum plates, either in Petri's dishes, or in test-tubes along with the above mannite solution. It grows best at about 30° C. The author has found it in garden and field earths from various parts and also in street dust. It was constant in earth at a depth of 50 cm. At depths of 100–190 cm. it did not seem to be present, although *Clostridium pastorianum* was. Its most interesting characteristic is that it absorbs atmospheric N, even in pure cultures. In a series of experiments, after nine weeks growing in the mannite solution, the N-gain was found to be 12–24 mg. per litre. In mixed cultures the growth is much more luxuriant and the N-gain greater, up to 80 mg. per litre, after one week. The greatest N-gain seemed to be in the gypsum cultures, they being under very aerobic conditions. They furnished, in periods varying from one to three weeks, about 4 mg. N each, and as the quantity of the nutrient solution, used in each, was about 20 c.cm. the amount of N per litre would be about 160 mg.

Attempts to sow earth with cultures of these organisms for the purpose of increasing its nitrogenous value have not hitherto been satisfactory.

**Disease of the Rat caused by an Acid-fast Bacillus.\***—G. Dean records a case of a disease of the rat (*Mus decumanus*) affecting skin, musculature and glands, a disease already described by Stephansky and by Rabinowitsch. Among other lesions, the skin of thorax and abdomen was denuded of hair, and on the bare area were several nodules the size of peas. The axillary glands were enlarged, and the abdominal wall was thickened and caseous. Practically the whole area involved was packed with acid-fast bacilli. They were present not only in necrotic areas, but in the cells themselves. The bacilli are about 5  $\mu$  in length, and frequently present the granular appearance of the bacillus of leprosy. They stain with Gram and are both acid- and alcohol-fast. Attempts to cultivate the bacillus on ordinary media failed, as also did attempts to infect white rats.

**Acid-fast Bacilli in Python reticularis.†**—V. Hausemann found, in the neighbourhood of the pancreas in a *Python reticularis*, a grape-like mass having some resemblance to Perlsucht. Microscopically, however, the masses were seen to consist of granulation tissue, with densely packed round cells, but with no caseation, giant cells, nor calcification. Foci of suppuration were seen, in the neighbourhood of which were large cells with characteristic granular protoplasm. With the usual staining method no bacteria were seen. With the use of Ziehl's solution and after treatment with Gabbet's solution, numerous red-stained rods appeared, resembling the tubercle bacillus in form and size, and sometimes having the irregular staining so frequent in that organism. By this staining method the granular appearance of the large cells was seen to be due to an accumulation of acid-fast bacilli in them. These large cells with their contained bacteria appeared morphologically equivalent to "lepra-cells." As all the material had been hardened before the

\* Centralbl. Bakt., 1<sup>o</sup> Abt., xxxiv. (1903) pp. 222–4.

† Tom. cit., pp. 212–3.

bacilli were noticed, no inoculation experiments could be carried out. It remains therefore unknown whether these bacilli were identical with the tubercle bacillus, or whether they were acid-fast bacilli different from it.

**Retting of Flax and Hemp.\***—J. Behrens, in order to determine the cause of this process, experimented with *B. fluorescens liquefaciens*, *B. subtilis*, *B. megatherium*, *B. mesentericus vulgatus*, *B. mesentericus fuscus*, *B. mycoides*, *B. coli communis*, *B. asterosporus*, and *Mucor stolonifer*. His method was as follows:—A number of hemp, or flax, stems were cut up and placed in wide-mouthed vessels with just enough water to cover them. On three consecutive days the flasks were subjected for 2 hours to steam sterilisation. A flask was then inoculated with one of the above-named organisms and incubated at 25° C. for periods up to 21 days, several uninoculated ones being treated similarly as controls. At the end of the period the extent of the retting was determined. The experiments showed that two only of the organisms were capable of causing the process, viz. *B. asterosporus* and *Mucor stolonifer*, the former being the more active. In the case of flax, *B. mesentericus fuscus* produced a doubtful retting.

**Presence of strictly Anaerobic Butyric Acid Bacilli and of other Anaerobic Species in hard Cheese.†**—A. Rodella worked with 20 samples of Parmesan and 10 samples of Emmenthal cheese. He used two methods: (1) That of Botkin in which about 1 gram. of cheese is added to sterile air-free milk, while yet hot, in a small flask. In the 30 experiments all gave positive results, butyric acid fermentation being set up by a non-motile bacillus within 24 hours. (2) .2-.5 gram. cheese placed in air-free bouillon, both with and without added sugar, was left at 37° C. for 3-4 days. The tubes were then heated to 80.1° C. and a few drops of the culture introduced into the deep layer of agar and gelatin. Of 14 experiments with Parmesan cheese 9 gave positive results. Five times was found what was probably the non-motile butyric acid bacillus of Schattenfroh and Grassberger. Three times the *Bacillus putrificus* of Bienstock was certainly identified. Twice a non-liquefying anaerobe was found which the author regards as a new species. Five experiments with Emmenthal cheese gave 4 positive results, the isolated anaerobes belonging to the group of butyric acid bacilli of Schattenfroh and Grassberger.

**Researches on Tetanus.‡**—H. Meyer and F. Ransom, in a research undertaken to throw light on the etiology of tetanus, first worked at *local tetanus*. They claim to have given a satisfactory interpretation of the *period of incubation*, to have discovered a form of tetanus confined to the sensory system, *Tetanus dolorosus*, to have established a *theory of action* of the tetanus toxin, and to have defined the sphere within which the serum treatment is effectual.

(1) *Local tetanus*.—Experiments in this connection show that the transport of tetanus toxin to the central nervous system takes place *only by way of the motor nerves*.

\* Centralbl. Bakt., 2<sup>o</sup> Abt., x. (1903) pp. 524-30. † Tom. cit., pp. 499-500.

‡ Proc. Roy. Soc., lxxii. (1903) pp. 26-30.

(2) *The period of incubation.*—Experimentally it is shown that the greater part of this period is the expression of the time occupied in the conveyance of the toxin from the periphery along the motor nerves to the susceptible centres.

(3) *Tetanus dolorosus.*—In all experiments with injection of tetanus toxin into the substance of the spinal cord, there was observed as a first symptom of intoxication a sensory disturbance, consisting in extreme hyperæsthesia, strictly localised, even when the muscular rigidity and the exaggeration of the reflexes were becoming general. Experiments made in this connection show that the tetanus toxin never reached the spinal centres by way of the sensory nerves; that the pain apparatus in the spinal cord is so insulated from the motor that an intoxication of the one group never goes over to the other; and that the actual movement of the toxin in the nervous system takes place, not in the lymphatics but in the protoplasm of the nerves.

(4) *Theory of action of tetanus toxin.*—The toxin is taken up from the point of injection by the motor nerves, along which it passes to the motor centres in the cord and excites there an over-irritability, resulting in tetanic rigidity in the affected limb. The excess toxin then passes in the fibres of the cord to the motor apparatus of the corresponding limb of the opposite side. After a time the nearest connected sensory apparatus of the reflex arc in the spinal cord is attacked. If the intoxication proceeds further, the motor tonus and the increased reflex irritability become general. The tetanus of warm-blooded animals consists of two processes. One is primary, a motor intoxication: local muscular rigidity; the other, secondary, is a local sensory intoxication: a diffused reflex tetanus, starting from the intoxicated neuron.

(5) *The behaviour of the tetanus anti-toxin in the organism.*—It was found that when tetanus toxin was introduced direct into a motor nerve, anti-toxin was practically inert. It is concluded therefore that anti-toxin does not reach the substance of the nerve-fibrils and centres, and will therefore render harmless only the toxin in the blood and lymph, leaving that already in the nerve-substance untouched.

**Experiments with Bacterial Light.\***—M. B. Issatchenko has studied the light produced by the *Photobacterium phosphorescens*, and has made experiments to determine the extent of its power in causing the transformation in plants of protochlorophyll into chlorophyll. All experiments were made in a perfectly dark room. The light was strong enough for small objects to be distinguished, and for the study of its spectrum which was from  $\lambda = 0.46$  to  $\lambda = 0.55$ , the clearest part being from  $\lambda = 0.48$  to  $\lambda = 0.51$ . In colour the light was greenish. The light from gelatin cultures attained its maximum in from 2–3 days. The experiments were made by exposing to the light for periods varying from 10 to 48 hours germinating seeds of clover, rye, and oats, and afterwards treating the shoots with 95 p.c. alcohol and examining the extract spectroscopically. An alcoholic extract was in all cases made also before the experiment and examined in the same way. In none of the latter was there evidence of chlorophyll, the band of protochloro-

\* Centralbl. Bakt., 2<sup>o</sup> Abt., x. (1903) pp. 497–9.



phyll only being present. In three out of four experiments the extract made from the shoots after exposure to the light showed in addition to the protochlorophyll band a distinct band of chlorophyll. The absence of chlorophyll occurred in the short 10-hour experiment.

The author claims that this formation of chlorophyll depends exclusively on the tension of the light, the quality of the rays not playing any rôle in the process if the rays of intensity are sufficiently great.

**Observations on the Flagella of the Tetanus Bacillus.\***—Silvio de Grandi, in an important paper, gives the results of his work on the flagella of the tetanus bacillus. He worked with two distinct races of the bacillus; he made his cultures in bouillon and on agar, and used both Buchner's tubes and an atmosphere of hydrogen. Preparations were made at different periods of growth, from 20 hours to 14 days. The staining methods of Löffler, Morax and Nicolle, Gino de Rossi, Trenkmann, and van Ermengem were employed, and the author suggests modifications of some of them. From the flagella standpoint he divides the bacilli into three groups.

(1) The most complete form. The bacillus is surrounded by numerous—50-70—very fine flagella  $1-1\frac{1}{2}$  times its own length.

(2) Many of the flagella of (1) have disappeared and the remainder, about 20-30, have lengthened out to 2 or 3 times the length of the bacillus and have become markedly sinuous.

(3) This form is characterised by the presence of a few, never more than four, much thicker flagella, "secondary flagella" (Kanthack and Connell), "Wimperhaar" (Löffler). There is in this form also a great diminution in number of the ordinary flagella. There may be seen only one "Wimperhaar" and no other flagella at all. When all flagella have disappeared sporification seems about to take place. The author regards these changes as involutive.

No. (1) is found most abundantly in early preparations after 2 days in bouillon or 3 days on agar. No. (2) predominates after 3 days in bouillon or 4 days on agar. After 4 days in bouillon or 5-6 days on agar No. (3) is almost exclusively found. Later than this flagella seem to decrease progressively so that after 10 days it is rare to find any at all.

As regards movement, the author has found most bacilli absolutely non-motile. In some of the smaller forms however he has noticed a slow and indistinct movement. He considers that to a great extent the flagella of the tetanus bacillus have lost their function.

**Flagellated Micrococcus found in a Septicæmia of Rabbits.†**—G. Catterina described a micrococcus obtained from the blood and spleen of rabbits suffering from a form of septicæmia. It stained well with ordinary stains, but not with Gram. Its diameter was  $1.5 \mu$ ; it was usually single but sometimes diplococcal forms were observed. It was very motile, and two flagella were demonstrated at opposite poles of the organisms. In gelatin stab cultures after 3 days appeared delicate oblique filaments growing out laterally from the needle track, while on

\* Centralbl. Bakt., 1<sup>o</sup> Abt. Orig., xxxiv. (1903) pp. 97-108.

† Tom. cit., pp. 108-112 (4 figs.).

the top surface of the medium was an irregular colony, whitish and warty in appearance. The gelatin was not liquefied. On agar and solidified blood-serum whitish irregular and raised colonies were developed. Broth became flocculent without surface pellicle. On potatoes the colonies were raised at the edges. The indol reaction was negative. Anaerobic growth was slow.

A loopful of the culture caused death of a rabbit in about 48 hours, and the micro-organism was found in the spleen and blood. Guinea-pigs and mice died in 40-60 hours. Fowls were unaffected.

The author was able to produce a certain degree of immunity in rabbits by injecting them with increasing quantities, 2-20 cm., of the filtered broth culture.

He considers the micrococcus a hitherto undescribed species and names it *Micrococcus agilis albus*.



## MICROSCOPY.

## A. Instruments, Accessories, &amp;c.\*

## (1) Stands.

Leitz' New Stand and Fine Adjustment.†—In this new model (fig. 152) Leitz has adopted the English method of applying the micrometer screw to the tube, and has, at the same time, abandoned the

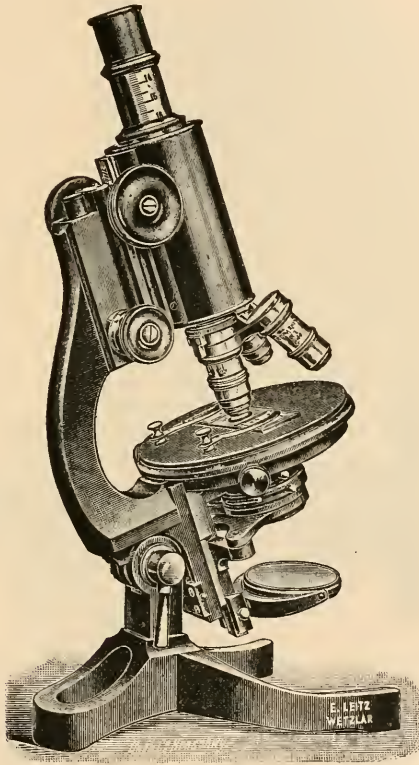

FIG. 152.

Continental type of stand. The build of the Continental stand is a necessary consequence of the straight tube and straight pillar of the upper part: hence, in the present stand greater freedom has been

\* This subdivision contains (1) Stands; (2) Eye-pieces and Objectives; (3) Illuminating and other Apparatus; (4) Photomicrography; (5) Microscopical Optics and Manipulation; (6) Miscellaneous.

† *Zeitschr. f. Instr.*, xxiii. (1903) pp. 79–81 (3 figs.).

attained in the disposition of the pillar and foot. The curving of the upper pillar affords a good grip for the Microscope and provides ample room for a large object-stage. In place of the usual mechanism of screws, levers, or inclined planes, a principle, apparently novel as regards the Microscope, has been adopted for the attainment of a fine adjustment: a disc (*f*, fig. 153) rotates about a strong axis and is bounded by a curved surface excentrically placed with regard to the axis: this disc raises the tube the desired distance. Fig. 153 is a vertical section through the mechanism of the micrometer adjustment. The periphery of the disc is made of two equal spirals which are placed together in a

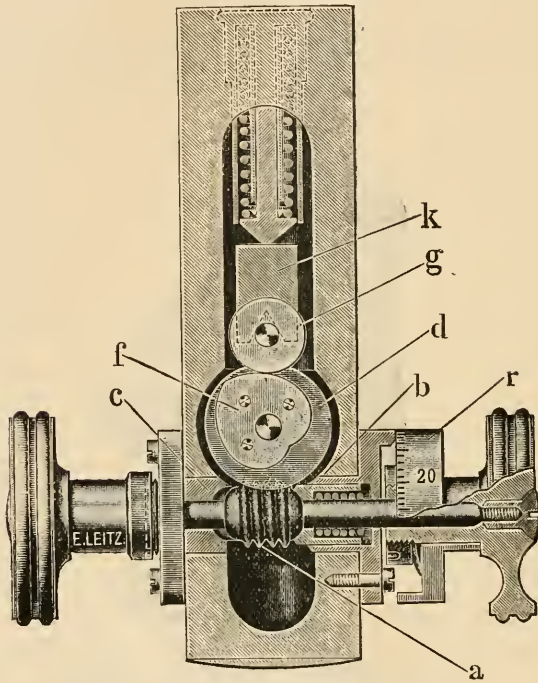

FIG. 153.

heart-shaped manner, thus forming a kind of cam. The spiral starts from the indent of the cam (i.e. the point nearest the rotation-centre) up to its apex: the range is about 3 mm., and the disc simultaneously travels an equal amount. A support *k* is placed on this spiral by means of the roller *g*; it shares in the movement and communicates it to the tube. The heart-shaped piece is rigidly connected with a toothed wheel *d*, which engages on two sides in the thread of an endless screw *a*. This double engagement of the teeth and axle is clearly seen in fig. 154. This endless screw is operated by a pair of milled heads placed under the milled heads of the coarse adjustment. The position *b* of the

endless screw *a* brings the latter by means of the unilateral pressure of a spring into close contact with the toothed wheel. By means of this pressure-position and the double gripping of the wheel and axle all backlash of both is avoided. The toothed wheel has 60 teeth and requires a half rotation to move the spiral from the indent of the cam to its apex and to perform the 3 mm. of motion. In one rotation, therefore, one tooth corresponds to a movement of 0.1 mm.; and a complete rotation of the axis *a* secures a complete rotation of the toothed

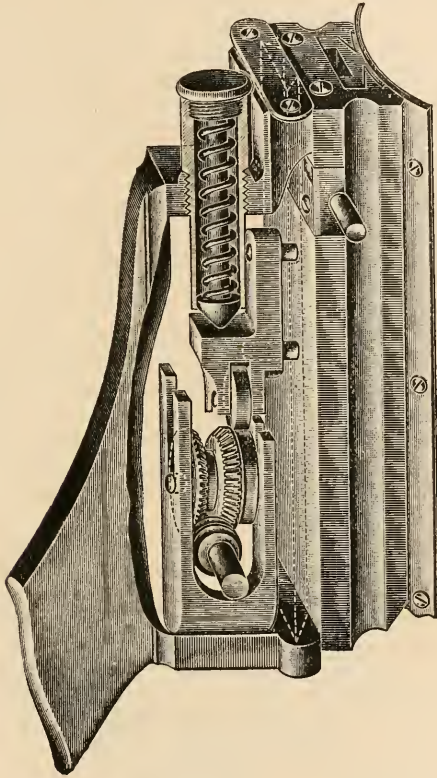

FIG. 154.

wheel. The drum *r* of the axis is divided into 100 parts: the rotation of one graduation of the drum-head corresponds, therefore, to a micrometric movement of 0.001 mm. The connecting piece between tube and pillar carries the rack-and-pinion coarse adjustment and bears on its hinder side a swallow-tailed piece fitting accurately into a corresponding groove of the pillar, and firmly screwed on to the bearer *k*. This bearer by means of the roller *g* sits on the surface of the spiral and shares both its rising and its falling movement. A spring inserted in a cylinder on the pillar of the stand over the support *k*, presses a pin

against the support and holds the roller in sure contact with the spiral. The pin is so situated on the support *k* behind the contact-point of roller and spiral (see fig. 154) that the spring-pressure and the strain arising from the weight of the tube and connecting piece equalise themselves, so that within the groove of the swallow-tail there is no side pressure on the sliding parts to affect the fine adjustment, and thus an unequal wear and tear of the guide surfaces is avoided. One effect resulting from the connection of the two spirals to the cam is that, owing to the endless action, there can be no over-winding and therefore no straining of the fine adjustment. Another advantage is that destruction, in the event of contact, of the cover-glass cannot occur, even if rotation of the screw is continued, for in this case the connection between roller and spiral is interrupted: the spiral then runs free, the tube gently sets itself on the cover-glass which, in the designer's experience, is capable of sustaining the weight of the light aluminium tube and the pressure exerted by the spring on the tube-holder and tube.

In connection with the foregoing stand and with special reference to the fine adjustment Mr. Nelson writes as follows:—

“The circular issued by Messrs. Leitz of Wetzlar throws an interesting side light on the ideas prevalent in Germany with regard to Microscope construction.

One of the causes assigned by Messrs. Leitz for the difference in construction of the Continental and English models is very curious—it is as follows: ‘The shape of the Continental stand is largely determined by the straight tube and the straight pillar, which are indispensable, owing to the long prismatic guides in the pillar.’ Many English Microscopes, however, have straight tubes and longer prismatic guides than exist in any Continental model, so that these points can hardly be said to determine the form of the model.

The truth is, that the non-inclining Continental model, with its small stage, was a cheap form, which did well enough to hold the magnifying glasses for which it was originally designed, but the moment it was used for purposes of delicate research it utterly broke down, for it was found wanting in every important point.

Messrs. Leitz admit that it fails when the stage is enlarged, and the distance of the body from the limb is increased, and anyone can understand how the weight of the body, acting at the end of the arm (virtually a lever), must jam the slides. This surely is an important point, for if the fine adjustment breaks down what is the use of the instrument?

The method which Messrs. Leitz have adopted in their laudable attempt to improve the radically bad Continental model is both complex and quite inefficient. The body is raised and lowered by a cam, which is rotated by an endless screw; the speed attained is  $\frac{1}{254}$  in. for each revolution of the pinion.

Passing over, without criticism, the complexity of this mechanism, it can be seen at once where the appliance fails, for it is impossible to determine the direction of the focussing movement, whether it is upwards or downwards. This, however, is a point of primary importance

in a Microscope, because there is no stereoscopic projection, and the shape of bodies can only be known by differences of focal adjustment.

The instrument, like all of Messrs. Leitz' work, is most beautifully made, and it is a thousand pities that Germans throw away such excellent work on such impossible models.

The cam was first applied to the fine adjustment of a Microscope by Wenham in 1886, but it was used for stage movements by Swift in 1884."\*

**New Regulating Arrangement for a Hot Stage.**†—The advantage of this apparatus, designed by R. Kraus, is "that a constantly warmed water-supply can be applied to an object-stage and keep it at a constant temperature the whole day long." The apparatus consists of a glass hollow stage communicating by means of indiarubber tubes with the two chambers of a heated reservoir. The whole arrangement involves the principle of circulation, and the effect is to produce a steady flow of water at a constant temperature through the stage. The water on leaving the stage goes to the lower chamber, which is a sort of furnace, whence it rises to the reservoir proper; thence it gravitates to the stage, and so on. The heating of the furnace is effected by a suitable gas flame, and a thermostat in the reservoir controls the temperature of the flow. The temperature of the stage is about 8° C. less than that of the reservoir and the object-holder would be about 4° C. still lower.

**Watson's New Scōp Mechanical Stage.**—The principal advantages offered by this new stage exhibited at the June Meeting (fig. 155)

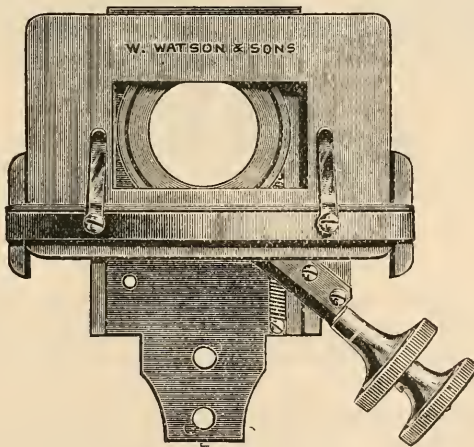

FIG. 155.

are great range of movement, as much as 3 in. being given in the horizontal direction, and a clear surface for working purposes. The

\* This Journal, 1886, p. 1052 (figs. 220 and 221).

† Centralbl. f. Bacteriol., xxxii. (1902) p. 467; and Zeit. f. Wiss. Mikr., xix. 1903) p. 347 (1 fig.).

two movements are effected by rack-and-pinion, by which an equal rate of progression is secured: they are actuated by two milled heads mounted on a common spindle on the Turrell system, and though the position of the heads is unusual it is found in practice to be extremely convenient. In size the stage is the same as that of the "H" Edinburgh Student's Microscope, but if desired it may be removed and replaced by a plain plate fitting in the same dovetails.

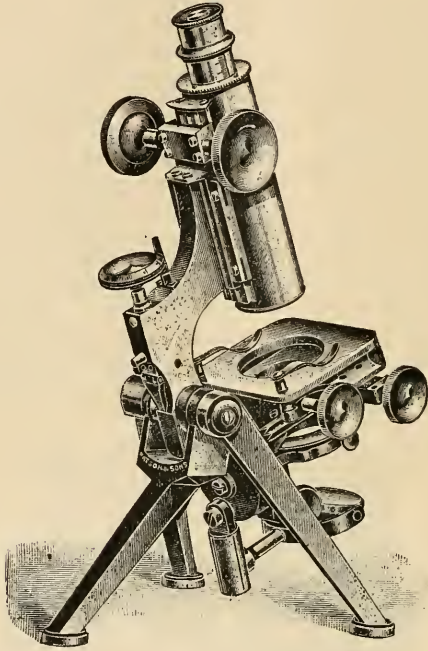

FIG. 156.

**Watson's New Pattern Portable Microscope.**—Figs. 156 and 157 show the new pattern portable Microscope which was exhibited and described by Mr. F. W. Watson Baker at the Meeting on June 20th: see *ante*, pp. 562-3.

**New Microscopical Stand with a Movable Stage capable of Large Movements.\***—Cl. Regaud and Nacet describe a stand which has a special form of movable object-stage and is geared so that the stage can be moved up and down. The stage is adapted for large object-slides 85 by 50 mm., and by means of a mark the object-holder can always be accurately brought back into the same position. Every part of the upper surface of the object-holder can be brought into view and

\* Arch. d'Anat. Micr., v. (1902) pp. 17-21 (2 figs.).



the whole surface can quickly or slowly be systematically explored. The movements are controlled by the left hand of the operator, his

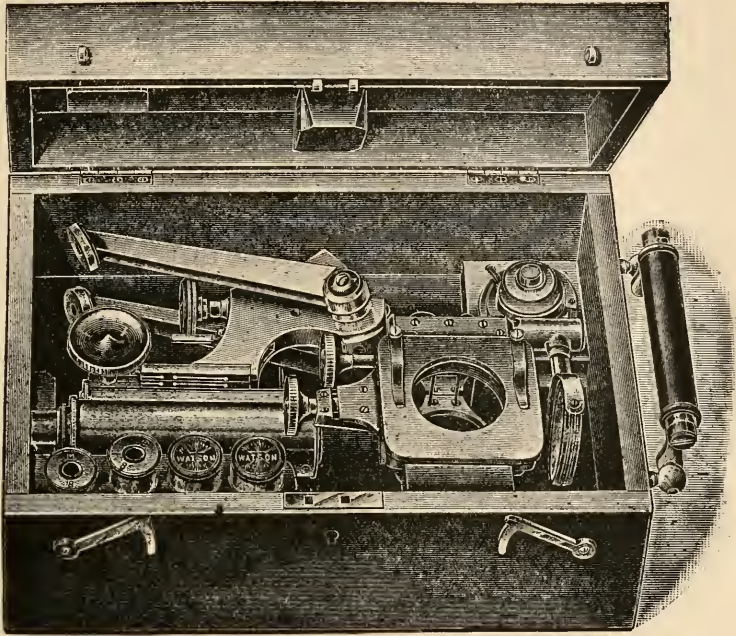

FIG. 157.

right being then free for the micrometer screw. The apparatus is thus especially suitable for the examination of a series of sections.

### (3) Illuminating and other Apparatus.

**Colour Illumination of Microscopic Objects.\***—S. E. Dowdy describes a simple procedure for making coloured gelatin discs for illuminating objects by Rheinberg's method.† First of all, obtain an ounce of good quality clear gelatin. Shred this up into small pieces and cover them with 4 oz. of water, and allow it to stand till quite soft; then add another 2 oz. of water, and warm gently on a water-bath (a saucepan containing a little water will do) until the gelatin dissolves. This will constitute our stock solution, which may be coloured as follows:—Procure half a dozen of the penny packets of anilin dyes, selecting brilliant contrast colours. Add about four grains

\* *English Mechanic*, lxxvii. (1903) p. 324.

† See this *Journal*, 1893, p. 373; 1899, p. 142.

of the dye to a teaspoonful of water; warm until dissolved; filter if solution contains any foreign matter, and add it to about an ounce and a half of the stock solution of gelatin whilst still warm, and therefore in a liquid condition. Now clean some  $\frac{3}{4}$  in. circular cover-glasses and place them on a sheet of white paper. With a glass rod deposit a little of the warm gelatin solution on the centre of one of them, and quickly lower upon it another cover-glass, pressing it down to remove superfluous liquid. The gelatin will set almost immediately, with the result that a thin film of it, protected on both sides from injury, will be obtained. Such films can be cleaned like an ordinary cover-glass with no fear of their coming apart. Some background stops will now be required, and these can be prepared as follows. With a fine camel-hair pencil paint a circular disc of the coloured gelatin solution in the centre of a cover-glass, and allow it to dry. Care should be taken to put it on thinly and evenly, and a neater job will be made of it if a fine ring of varnish be first put on the cover with a turntable, afterwards painting in the central area. Two or three dozen films should be prepared whilst the materials and solutions are about, as they are always handy.

**Early Glass Micrometers.**—Mr. E. M. Nelson presented at the June Meeting two micrometers for the cabinet of the Society, and has supplied the following description. These two micrometers are interesting as being early specimens of a glass micrometer. They are ruled on the slides (2 by  $\frac{3}{4}$  in.), and no cover-glass is used. They are both ruled in squares, one in  $\frac{1}{100}$ , and the other in  $\frac{1}{200}$  of an inch. I have compared the  $\frac{1}{200}$  with an accurate micrometer with some care, and find that the average of the  $\frac{1}{200}$  is slightly in excess, viz.  $\frac{1}{198}$ . The greatest interval is  $\frac{1}{196}$ , and the least  $\frac{1}{206}$ ; probably an error of two units in the fourth decimal place was not thought much of in those early days of micrometry; one of the interspaces however is only  $\frac{1}{114000}$  in. in excess. The  $\frac{1}{100}$  was only cursorily examined, but the ruling seemed more even; but the error, like the other, was in excess of the truth.

Probably these micrometers were ruled by Powell, as they belonged to a Microscope made by him in 1838.

**Method of Demonstrating Newton's Colours by Transmitted Light.\***—It is well known that, if white light be passed through a thin film, part of it will be reflected twice within the film and will cause interference and colour phenomena. These are usually very faint because the amount of light which is thus reflected is so small as compared with what passes directly through, as to have but a slight effect. If, however, the same wave-front be passed through a uniform series of films, successive portions of certain colours should be blotted out in each film, while other colours which get through the first film without interference, should emerge from each of the other (similar films) without interference, and the colour effect should be cumulative. At the suggestion of Prof. Barus, these surmises have been empirically verified and excellent results obtained. If a number of wire rings of the same

\* Amer. Journ. Sci., xv. (1903) pp. 224-5.

size be mounted in parallel planes, and dipped together into a soap solution, their planes being kept perpendicular to its surface, a suitable series of films results, through which light can be passed and caught on a sheet of paper, showing the desired phenomena very beautifully. Since each film, under the action of gravity, is a very thin wedge, the colours are in horizontal bands, appearing first at the top (where the wedge is thinnest) and moving slowly down across the field as the films evaporate, to be succeeded by other bands of lower orders. Indeed, good films will often hold until two-thirds of the field is coloured with the yellowish-brown of the first order. If the paper be replaced by a good lens and the colours projected on a large scale upon a suitable screen they can be strikingly demonstrated to a class. In practice the important thing seems to be uniformity in size and alignment in the set of rings. The author makes them of 5.5 cm. in diameter, of galvanised iron wire ( $d = 1.25$  mm.), the ends being twisted together into a sort of handle. Such rings can be temporarily strung on three rods notched at appropriate intervals to insure parallelism in the planes of the rings, while the handles are being clamped between two pieces of soft wood. The rings should be at least a centimetre apart to avoid cylindrical and irregular films, and from fifteen to thirty are sufficient. Before the films have become thin enough to show colours, certain other interesting phenomena of a circulatory nature are noticeable and can be studied.

**Wide Illuminating Cones.\***—"Villagio" expresses his gratification as to the improved results he has obtained by the use of wide-angled condensers and apertures. He was particularly pleased with the appearance of *A. pellucida* mounted in realgar, the objective oil-immersion being 1.35 N.A., and the condenser worked up to rather over 1.0 N.A. immersed. The lines were exquisitely sharp with widest axial cone, and on removing the eye-piece the two spectral beams were seen partially eclipsed by the edge of the back lens. On closing the diaphragm it was instructive to note that these beams diverged until they disappeared, this happening at about .8 to .9 N.A. On using the eye-piece with this cone it was, of course, found that the lines were invisible. The writer has also found the same arrangement of lenses and illumination excellent on sections of well-stained material, beautifully clear images being obtained. Similarly satisfactory results were obtained with living bacteria.

J. Rheinberg,† however, in discussing Villagio's communication, points out that arguments in the controversy of wide-angled *versus* narrow-angled cones are apt to overlook the nature of the object to which such cones may be applied, and that great caution should therefore be employed before any hard-and-fast rules be adopted. After discussing the effects produced by various kinds of illumination he concludes by pointing out that "whilst wide axial cones of illumination may cast a haze over, or completely obliterate the appearance of structure, they cannot, save in very exceptional circumstances, create an appearance of false structure, whereas as soon as we proceed to narrow cones, or use oblique,

\* English Mechanic, lxxvi. (1903) p. 463.

† Tom. cit., pp. 524-5.

or annular illumination, such appearances are frequently created. Necessary as the latter modes of illumination may at times be, they require far more care in interpretation than anything that can be seen with a wide cone of light."

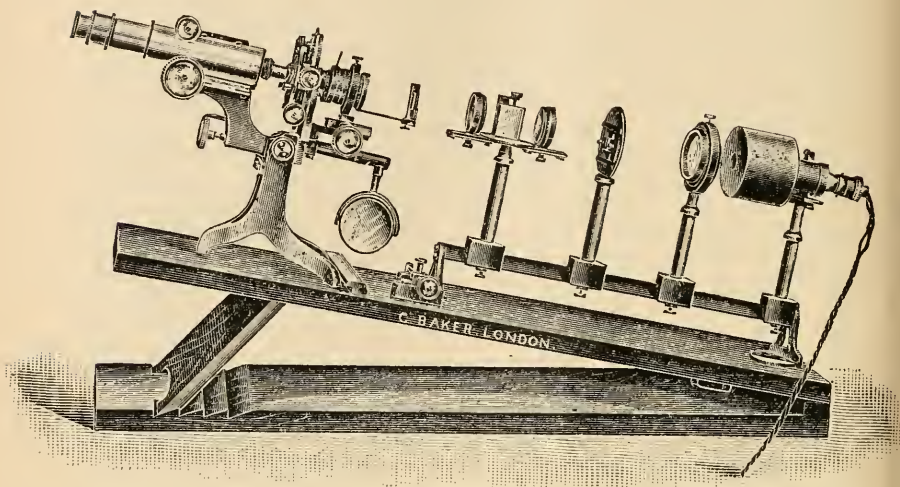

FIG. 158.

**Monochromatic Light Apparatus.**—Fig. 158 illustrates the apparatus exhibited and described by Mr. C. L. Curties at the Meeting held on May 20th : see *ante*, pp. 378–9.

MACÉ DE LÉPINAY, J.—*Projections Stéréoscopiques*. *Journ. de Phys.*, 1902, p. 311.

#### (4) Photomicrography.

**Stereoscopic Photomicrography with Weak Magnification.\***—W. Scheffer's explanation of the theoretical principles underlying the preparation of stereoscopic photographs of microscopic objects are set forth in figs. 159 and 160. The magnification is supposed to be weak, and for such films photographic objectives of short focus without oculars suffice. X, Y are the points intended to be stereoscopically presented in magnification. The objective O, with the camera and ground glass screen, is first of all set perpendicularly to the object plane (C D, E F, are the planes; A B, the optic axis). M is the point at which the optical axis of the two positions of the objectives intersect with the axis of the camera. This point must come exactly in the centre of the object; it is then only necessary to provide for the movement of the objective and of the focussing screens. The camera is first moved to the right and then equally to the left (into the positions M H, M G); the result being that projections are received on the screens P' P' and

\* *Zeitschr. wiss. Mikr.*, xix. (1903) pp. 289–96.

PP, which give the single images of a stereogram and represent the relative positions in space of the points X, Y.

Fig. 160 shows the final arrangement of the single pictures i. and ii. for the stereogram. The combination-points ( $x$  and  $x_1$ ) corresponding to X lie closer together in the stereogram than those for Y ( $y$  and  $y'$ ); X is therefore presented to the observer nearer than Y. Two conditions

FIG. 159.

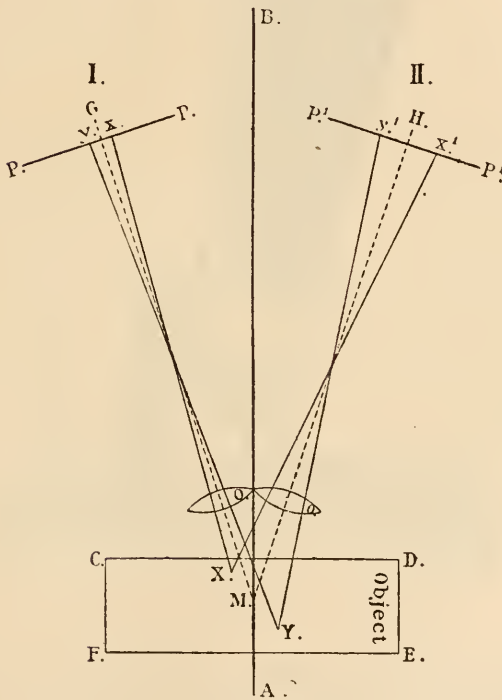
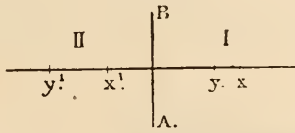

FIG. 160.

are necessary for success : first, that the points X and Y must lie within the penetrating power of the objective ; secondly, the object must not project so far from the object-plane that the side views exceed those same limits of penetration. The "angle of inclination" is the inclination of the optic axis of the camera to the vertical, and it is found that an inclination angle of  $3^\circ$  gives the best results.

The arrangement of the apparatus is shown in fig. 161. A strong pillar B B rises perpendicularly from the base and bears a pivot D, round which is a movable arm C, whose (partial) rotations give the lateral inclinations of the camera. The angle of inclination can be accurately read off to  $\frac{1}{4}^{\circ}$  on the scale at F. The screw B serves as a clamp. The coarse adjustment of the objective is effected by a push-motion of the lower part of the camera on the pillar T; the fine adjustment is by rack-and-pinion. When a stereoscopic plate is to be taken a pin is thrust through the hole visible in D, and its point accurately marks the inclination axis. The camera is, however, first brought into

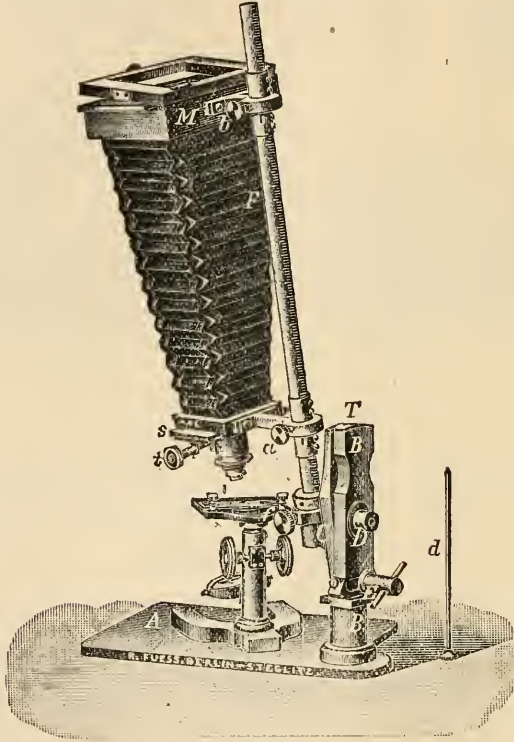

FIG. 161.

the proper position for the negative and is clamped by the screw *f*, as the pin must also pass through a hole in the pivot of *F*. The point of the pin, as well as the objective, is now finely adjusted, and, by means of slight lateral movements of the objective board combined with slight push movements of the pin, is brought into the centre of the focussing screen. The frame is so arranged that the perpendicular to the centre of the screen intersects the rotation axis. When the image of the pin-point has been thus sharply defined in the centre of the screen, the objective is orientated and the pin drawn out. The stage with the object is then so orientated on the foot-plate that the

image of the object-centre comes in the centre of the screen. The fine adjustment of the screen image is effected by the raising and lowering of the object. In this way the object is brought into the intersection of the optic axis of the camera and of the inclination axis. The illumination, especially with reflected light, is of the highest importance and should, as far as possible, fall perpendicularly on the inclination plane; otherwise, the two stereograms would be unequally illuminated.

The apparatus is made by R. Fuess & Co.

**New Method of Focussing in Photomicrography.\***—Katharine Foot and Ella C. Strobell add some notes on their method of focussing.† This method offers special advantages for the vertical camera and daylight illumination, as it does away with the use of the ground glass, a minus spherical lens being substituted for the purpose of focussing. These lenses can be obtained from any optician, and a series (omitting the half numbers) ranging from  $-1$  D to  $-12$  D, will furnish the equipment necessary for photographing at 1200 diameters or less, with most combinations of objective, eye-piece, and bellows drawn. The lens for a definite magnification depends upon the eyesight of the operator. The selection of this lens is a simple matter and can be determined by taking one photograph. The method, in brief, is as follows:—"Instead of attempting to focus on the ground glass fine details impossible to see with daylight illumination, the change of focus necessary to throw the exact image (selected for the photograph) on the ground glass, is accomplished by focussing *through* a minus spherical lens placed on top of the projection ocular. This lens is removed before the plate is exposed. The *photograph* is not taken through the lens. The use of these lenses is simply a device for compelling the eye to see the plane of the preparation that is projected on the ground glass." Before exposing the plate a delay of a few minutes is necessary to see that the focus does not slip. It is also necessary to see that such a length of draw-tube is used as will give agreement in results as tested by the Zeiss stage micrometer and by the Zeiss micrometer eye-piece. A few photographs of the stage micrometer, taken with different combinations of lenses and bellows draw, provide an accurate register of magnifications, in convenient form for reference in selecting the lenses and draws needed for a given magnification. In using this method of focussing, it is a great aid to determine the limits within which a sharp focus can be expected, for it is easy to strain the eye and see details beyond these limits; the negative in this case giving disappointing results.

**Photographic Lenses.‡**—Under this title, C. Beck and H. Andrews have compiled a book intended for the use of the non-mathematical photographer. But so much of the work is occupied with an explanation of the properties of lenses that it cannot fail to be of interest to microscopists. The diagrams and illustrations are very numerous, and the plates devoted to such subjects as curvature and distortion are remarkably effective.

\* Journ. App. Micr., v. (1902) pp. 2082-4 (1 fig.).

† Zeitschr. wiss. Mikr., xviii. (1902) pp. 421-6 (1 pl.); and this Journal, 1902, pp. 490-1.

‡ Published by R. & J. Beck and Percy Lund, Humphries & Co. (second edition) London.

## (5) Microscopical Optics and Manipulation.

EVERETT, J. D.—On the Resolving Power in the Microscope and Telescope

*Rep. British Assoc. Glasgow*, 1901, p. 569.

STREHL, K.—Ueber Luftschlieren und Zonenfehler.

*Zeit. f. Instrumentenk.*, XXII. (1902) p. 213.

VOLKMANN, W.—Ein neues Geradsichtprisma und ein neues Flüssigkeitsprisma.

*Ann. d. Phys.* [4] VIII. (1902) p. 455.

## (6) Miscellaneous.

**The Microscope.\***—Under this title, A. S. Percival contributes to the *English Mechanic* a brief but clear and interesting explanation of the peculiarities of lens structure concerning the Microscope. He deals, *inter alia*, with magnification, spherical aberration, chromatic aberration, apochromatic objectives, size, brightness and flatness of image, and Huyghenian eye-pieces.

**Wave-length Tables of the Spectra of the Elements and Compounds.***Rep. Com. Brit. Assoc.*, 72nd Meeting, Belfast, 1902.  
London (J. Murray) 1903, pp. 137-74.**B. Technique.†**

## (1) Collecting Objects, including Culture Processes.

**New Economical Thermostat of Simple and Light Construction.‡**

C. Tonzig describes a thermostat which can be easily and cheaply made by an ordinary joiner and tinsmith, and which is well adapted for a temperature of 20° or 22° C. It measures 40 × 60 × 75 cm., and is made of wood, 2 cm. thick. Through the middle of the chamber a cylindrical tube of zinc passes vertically. This cylinder extends 5 cm. above the roof of the chamber, and below the floor it expands in the form of a cone, which is closed at the bottom by a plate of copper, this part being exposed to the flame when the thermostat is in use, and the cylinder full of water. The upper end of the cylinder has in it two openings, one for the thermo-regulator and another for a thermometer, to gauge the temperature of the contained water. In the roof of the chamber near one of the sides is another opening for a thermometer, to gauge the incubator temperature. The diameter of the cylinder is 7.5 cm., that of the base of the cone 18 cm., its capacity, therefore, is about 4900 ccm. The author uses a Soxhlet's thermo-regulator, but when gas is not available, a constant temperature can be maintained by the use of one or more night-lights in oil. The air of the chamber is warmed by convection of heat given out from the cylinder. The temperature was found by experiment to be uniform in all parts of the upper part of the thermostat. In the lower part the temperature was a

\* *English Mechanic*, lxxvi. (1903) pp. 430-3 (15 figs.).

† This subdivision contains (1) Collecting Objects, including Culture Processes; (2) Preparing Objects; (3) Cutting, including Imbedding and Microtomes; (4) Staining and Injecting; (5) Mounting, including slides, preservative fluids, &amp;c.; (6) Miscellaneous.

‡ *Centralbl. Bakt.*, 2<sup>te</sup> Abt., x. (1903) pp. 531-4 (1 fig.).



little lower ( $\cdot 5^{\circ}$ – $1\cdot 5^{\circ}$  C.). With regard to constancy of temperature, it was found that with a fluctuation of  $8^{\circ}$  C. in the room temperature, the change in that of the thermostat did not amount to  $2^{\circ}$  C. With slight fluctuations in the room temperature, that of the thermostat may be regarded as constant. The approximate cost of the apparatus, with thermo-regulator, thermometers, rubber tubing, and lamp, is from 25 to 30 fr.

**Milk-Agar as a Medium for the Demonstration of the Production of the Proteolytic Enzyme.\***—Referring to papers by E. v. Freudenreich and J. Thöni, and by E. G. Hastings,† C. Eijkman claims priority in suggesting the use of milk-agar for the above purpose, and in showing that the clearing of this turbid medium depends on the peptonising of the casein and that the casein-splitting enzyme is identical with the gelatin-liquefying one. He argues that while both milk-agar and gelatin are useful in distinguishing between peptonising and non-peptonising colonies, the former had the advantages of not liquefying and of a higher melting-point. The author also advocates the use of the "Diffusionsmethode" for the demonstration of the production of the fat-splitting enzyme.

#### (2) Preparing Objects.

**Decantation Method for Cleaning Diatoms.‡**—S. Broughton remarks that diatoms should be treated with acid to clear from all soluble matter and afterwards poured into a tall glass jar. Then have ready a siphon, and when the coarser particles have settled down siphon off to within an inch of the bottom; then empty the sand into another vessel and pour the portion first siphoned off into the glass jar and siphon off again to within an inch of the bottom. Empty the portion left into another vessel and repeat as often as thought desirable, keeping each separate, and at the last let it stand some time, allowing the diatoms to settle down, and then siphon off the clear water. They should then be fairly free from foreign matter. Each lot may then be tested to see if any diatoms are left in, and if so the process should be repeated.

#### (4) Staining and Injecting.

**Apparatus for the quick and uniform Staining of Serial Sections and for the Treatment of them in Number with Reagents.§**—This apparatus, made by R. Jung, of Heidelberg, consists of a glass vessel,  $70 \times 40 \times 90$  mm., into which fits a carrier for 10 slides made of nickel wire with sloping cross-bars of tin for the slides to rest on. These cross-bars are turned up at the edge so that the slides cannot fall off. A ring of wire allows the carrier to be lifted out without the fingers coming in contact with the reagent. The glass vessels are very cheap and it is convenient when working to have a number of them, each containing a separate reagent or stain, the carrier holding the slides being lifted from one to the other.

\* Centralbl. Bakt., 2<sup>o</sup> Abt., x. (1903) p. 531.

† Op. cit., 1<sup>o</sup> Abt., xxix. (1901) No. 22.

‡ English Mechanic, lxxvii. (1903) p. 444.

§ Zeitschr. angew. Mikr., ix. (1903) pp. 57–8.

**Modification of the Romanowsky Stain.\***—H. F. Harris while studying the malaria parasite, found the Romanowsky staining method and its many modifications uncertain. He recommends that, in place of the methylen-blue solution being mixed with the eosin, they should be used separately. His method is as follows:—Place the blood-film in a 1–1000 solution of Gruebler's water-soluble eosin for 30 sec. to 2 min.; well wash and place in a solution containing 2·5–5 parts Unna's alkaline methylen-blue, with distilled water to make 100 parts, for 5–10 minutes if the preparation is recent, longer if it is old. (To this solution 2·5 parts of a 1 p.c. solution of methylen-blue may be added with advantage.) Wash again, and if the film be too blue pour on it a solution of Unna's glycerin-ether mixture made by adding one drop of this compound to 10 c.cm. of water, then after a few seconds wash, and dry without heat. The author claims that by his method very old preparations may be stained. For fixing the films he advocates a few seconds in Reuter's 10 p.c. formalin and alcohol mixture.

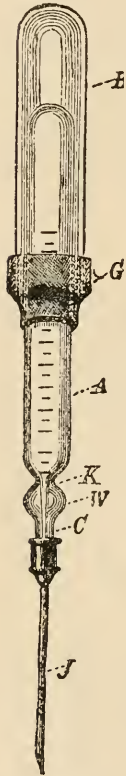

FIG. 162.

**New Sterilisable Hypodermic Syringe for Aseptic and Bacteriological Injection Experiments.†**—Made by Christian Kob and Co., Stützerbach. The syringe described (fig. 162) is not really new, having been made by the same firm for several years. It consists of an inner glass tube A almost closed at one end, a small hole ·5–1 mm. wide being left. At the other end there is first a constriction K, then a bulging W, and lastly a cone C ground to fit the hollow needle. The lower two-thirds of this tube are graduated up to 10 c.cm. outside, and two-thirds the length of A is another glass tube B wholly closed at the end. It is connected with A by means of a rubber ring G which while taking a firm grip of B is able to slip up and down A easily but hermetically. When B is drawn out the liquid to be injected is drawn up into A, and when the movement is reversed it is expelled. Simplicity, cheapness, and easy sterilisability are claimed for the syringe; also that it can be used with one hand, and can be laid down when full or even inverted.

**New Method of Counting the Corpuscles of the Blood.‡**—W. M. Strong and C. G. Seligmann. A measured quantity of the blood is mixed with a measured quantity of a fixing solution with which is combined a suitable stain. A measured drop of the mixture is allowed to evaporate to dryness on a slide and then is mounted in balsam. The number of corpuscles, red

(6) Miscellaneous.

**New Method of Counting the Corpuscles of the Blood.‡**—W. M. Strong and C. G. Seligmann. A measured quantity of the blood is mixed with a measured quantity of a fixing solution with which is combined a suitable stain. A measured drop of the mixture is allowed to evaporate to dryness on a slide and then is mounted in balsam. The number of corpuscles, red

\* Centralbl. Bakt., 1<sup>re</sup> Abt. Orig., xxxiv. (1903) pp. 188–91.

† Zeitschr. angew. Mikr., ix. (1903) pp. 58–61 (1 fig.).

‡ Brit. Med. Journ., July 11, 1903, pp. 74–7.

or white, in the whole drop is then counted. In making the solutions the authors advocate the use of tabloids, as follows :—

<i>Sol. A (for white count).</i>		<i>Sol. B (for red count).</i>	
Tabloid	{ Sodium chloride . . . . .	Tabloid	{ Sodium chloride . . . . .
	{ Methyl-violet . . . . .		{ Eosin . . . . .
	{ Formalin (neutral) . . . . .		{ Formalin (neutral) . . . . .
	{ Distilled water . . . . .		{ Distilled water . . . . .
	.25 grm.		.25 grm.
	.004 grm.		.0025 grm.
	.5 c.cm.		.5 c.cm.
	30 c.cm.		30 c.cm.

White cell count : 5 c.mm. of blood are mixed with 495 c.mm. of solution A and well stirred. This is allowed to stand for about 5 minutes. 5 c.mm. of this is taken and blown out on a slide so as to form a drop about 10 mm. in diam. This is allowed to dry and is mounted.

The white cells are stained and easily seen. The actual count is made with  $\frac{1}{8}$  objective, and the whole drop is gone over in parallel and contiguous lines from field to field. The use of an oblong diaphragm introduced into the eye-piece is recommended for convenience in counting. The count takes from 20–30 minutes. The 1–100 dilution must of course be allowed for in making the final calculation.

Red cell count : 5 c.mm. of the first (methyl-violet) dilution are mixed with 995 c.mm. of solution B ; 5 c.mm. of this are taken and treated as before. This time however the dilution will be 1–20,000.

The dilutions may be modified to suit very high or very low blood counts.

The authors claim for their method permanency of the preparations, and elimination of possible error due to differences in depth of the cells in ruled counting chambers.

FRIEDBERGER, E.—*Die allgemeinen Methoden in der Bacteriologie.*  
 Jena (Fischer) 1902, 3 Lief., 397–525 pp., 85 figs.

KAMEN, L.—*Anleitung zur Durchführung bacteriologischer Untersuchungen für klinisch-diagnostische und hygienische Zwecke.*  
 Wien (Safar) 1903, 8vo, 311 pp., 118 figs., and 12 pls.

MEZ, C.—*Mikroskopische Untersuchungen, vorgeschrieben vom Deutschen Arzneibuch. Leitfaden für das mikroskopisch-pharmakognostische Praktikum an Hochschulen und für den Selbstunterricht.*  
 Berlin (Springer) 1902, 8vo, 153 pp., 153 figs.

### Metallography, &c.

**Chemical Composition of Limestones. Microscopical Methods.\*—**  
 E. A. Skeats in investigating the mineral character and the changes in the matrix of organisms in limestones, taken from certain upraised coral islands, often found it difficult to distinguish between aragonite and calcite, and occasionally between calcite and dolomite. For the former purpose he used Meigen's test which depends on the fact that when aragonite is boiled with a solution of cobalt nitrate it is coloured red, whereas calcite is unaffected. The author used the test in the following way: a polished slice of limestone, consisting of coral fragments, gastropods, echinid spines, Halimeda, &c., cemented with a large quantity

\* Bull. Mus. Comp. Zool. Harvard Coll., xlii. (1903) pp. 65–9.

of fibrous calcium carbonate, was boiled for half an hour with cobalt nitrate solution. Afterwards the slice was mounted, polished side down, and ground down till transparent. It was found that the (*aragonite*) corals, gasteropods and Halimeda were stained red, while the (*calcite*) echinid spines were unaltered, as was also the cementing fibrous calcium carbonate.

There was seldom difficulty with calcite and dolomite, but in cases of doubt Lemberg's test was applied. This consists in treating the exposed surface of a thin section for 5–15 minutes with a solution containing a mixture of aluminium chloride and hæmatoxylin. Dolomite is unchanged, but a deposit of aluminium hydrate forms on calcite and stains reddish-purple. The staining solution is prepared by dissolving four parts of dry aluminium chloride in 60 parts of water and adding six parts of logwood. The whole is boiled and stirred for 25 minutes, and made up to original bulk. The author did not get good results if the stain remained on the rock for more than 15 minutes.

**Red Rain.**\*—F. Chapman and H. J. Grayson discuss the phenomenon of red rain with special reference to its occurrence in Victoria, and append a note on Melbourne dust. In two samples which fell at different times, they identified fragments of numerous minerals, diatoms, vegetable tissue and spores, sponge spicules, lorica of a rotifer, and various bacteria.

The Melbourne dust contained besides fragments of numerous minerals, cosmic dust, greenish-brown glassy spheres, and bits of rotifers and diatoms.

**New Etching Reagent for Polished Steel Sections.**†—F. N. Speller suggests the following method of developing the structure of iron and steel specimens. From 2 to 4 c.cm. concentrated nitric acid are slowly run into 100 c.cm. C. P. glycerin and the solution well mixed. After polishing and drying the specimen the surface is treated with a drop of C. P. glycerin, which is gently rubbed on the steel with the tip of the finger. A drop of the etching solution is now applied and friction with the finger continued until the surface is etched to the degree required. By fastening the specimen in a suitable holder the progress of the action of the acid may be followed through the Microscope and the development of the structure checked at the proper time by wiping the glycerin off with a soft cloth, and applying a drop of caustic soda-glycerin for a minute. The author states that the process works very well with low-carbon steels, the pearlite and granular structure being sharply defined, while the ferrite remains unstained even after 24 hours' continuous application of the etching solution. The chemical composition of this solution is not positively known, but it probably contains glyceric acid. It is found desirable to prepare a fresh solution every week and to keep in stock solutions of various strengths. The nitric acid used should not be fuming, otherwise nitroglycerin would be formed—a very dangerous substance.

**The Microscope in Crucible Steel Manufacture.**‡—J. J. Mahon points out that the Microscope, in order to be of any practical assistance

\* *Victorian Naturalist*, xx. (1903) pp. 17–32 (2 pls.).

† *Metallographist*, vi. (1903) pp. 264–5.

‡ *Tom. cit.*, pp. 195–6.

to the manufacture of fine steel, should be used on the ingot immediately after it is cast. It must be borne in mind that while good steel can be spoiled by bad treatment, bad steel cannot be converted into good steel by any kind of treatment except by remelting it. Hence the necessity for immediate examination.

#### Simultaneous Presence of Ferrite and Cementite in Steel.\*—

E. F. Lange has arrived at the conclusion "that there can be no possible doubt, as Mr. Stead says, that structurally free cementite and ferrite may be obtained in the same steel. The conditions favourable to the formation of this structure are an extremely slow cooling between 700° and 600°." In a postscript, A. Sauveur admits the soundness of the conclusion.

**Effect of Superheated Steam upon the Tensile Strength of Alloys.†**—J. L. Hall has studied this subject with especial regard to alloys of copper, as experience has quite generally indicated that that metal and some of its alloys have proved unreliable when subjected to the action of highly superheated steam. His experiments point to the conclusion that the tensile strength of bronze is lessened after a first heating and cooling from 320° C., but that subsequent treatment of this nature had little effect upon the ultimate strength.

**Improved Method of Identifying Crystals in Rock Sections by use of Birefringence, and Improved Polarising Vertical Illuminator.‡** J. Joly describes a method of observing on an ordinary rock-section the interference tints proper to double the thickness of the section, and of thereby producing discriminative effects not possible to obtain in the ordinary mode of observation. The method consists in placing a plane reflecting surface (polished speculum metal, preferably) beneath the rock-section as it rests on the stage of the Microscope, and transmitting, by means of any vertical illuminator (as used for the examination of metals, &c.), a plane polarised ray vertically downwards through the rock-section. The ray reflected from the speculum metal is again returned through the object-glass, and, after passing through the analyser, shows to the eye the retardation proper to double the thickness of section. In this manner the range of colour-variation from one species to another is greatly increased; in fact, what differences exist for the single thickness are now doubled in amount.

In this method a certain objection applied, in some degree, in all cases—a want of verticality in the downward directed ray, which involved necessarily that the section and its images in the reflector did not accurately overlie one another. In rocks of fairly coarse grain this did not signify; but in those of finer grain, an unpleasant overlapping of the colours of adjacent crystals occurred in the plane of incidence and reflection. In all the forms of the apparatus there was also required a separate polariser to polarise the beam entering the illuminator. The author has found that the simple vertical illuminator described in Messrs. Watson's catalogue gives very satisfactory results. The illu-

\* *Metallographist*, vi. (1903) pp. 9-13 (1 fig.).

† *Tom. cit.*, pp. 3-8 (5 figs.).

‡ *Sci. Proc. Royal Dublin Soc.*, ix. (1901) pp. 485-94 (2 figs.); x. (1903) pp. 1-5 (1 fig.).

minator, consisting of a cover-glass contained within a collar, is inserted just above the object-glass, and is inclined so that rays entering an aperture in the front of the collar are, in part, reflected by the cover-glass (which can be rotated on a horizontal axis into the suitable inclination), and thence pass downward through the object-glass and illuminate the opaque object under examination. The rays finally reaching the eye (returning through the object-glass much the way they came) are for the most part transmitted through the transparent reflector. It was found that the quantity of light transmitted was sufficient, even without the use of a lens, to strengthen the beam; there was no appreciable parallax, and even small microlithic felspars in basalt could be seen, each glowing with its own colour and with sharp margins. A notable advantage is that, with this mode of illumination, the use of a polariser is unnecessary. When the source of light is elevated above the horizontal level of the aperture in the illuminator, so that the ray nearly reaches the glass at the polarising angle, the polarisation is very complete.

**BARLOW, A. E.**—Microscopic Examination of Sections of Rocks associated with the Iron-Ore Deposits of the Kingston and Pembroke Railway District.

*Geological Survey of Canada, Ann. Rep., XII. (Ottawa, 1902) Svo. Report I. Appendix A, pp. 81-91.*

**CAMPBELL, E. D., & M. B. KENNEDY**—Probable Existence of a new Carbide of Iron.

[The authors give their reasons for the existence of  $Fe_2C$ , in addition to the well-known  $Fe_3C$ .] *Metallographist*, VI. (1903) pp. 139-47, 4 figs.

**CHATELIER, LE H., & M. ZIEGLER**—Sulphide of Iron: its Properties and its Conditions in Iron. *Metallographist*, VI. (1903) pp. 19-38, 28 figs.

**DUDLEY, P. H.**—Rolling and Structure of Steel Rails.

*Metallographist*, VI. (1903) pp. 111-29, 14 figs.

**EWING, J. A., & J. C. W. HUMFREY**—Fracture of Metals under repeated Alternations of Stress.

*Phil. Trans.*, Nov. 20, 1902; and *Metallographist*, VI. (1903) pp. 96-110, 15 figs.

**GUILLET, L.**—Sur la Micrographie des Aciers au Nickel.

[The author's experiments confirm the results obtained by L. Dumas in *Annales des Mines*, April 1902.]

*Comptes Rendus*, CXXXVI. (1903) pp. 227-8.

**HOWES, H. M.**—Iron, Steel, and other Alloys.

*Metallographist*, VI. (1903) pp. 179-95, 6 figs.

**MILERS, H. A.**—Mineralogy, an Introduction to the Scientific Study of Minerals.

[Described in the *Geological Magazine* for April 1903, p. 165, "as a really readable work, setting forth the principles of scientific mineralogy, and not unduly burdened with facts and technical details."]

London (Macmillan & Co.) 1902, xviii. and 584 pp., 2 col. pls. and 716 illus.

**Nickel Steel.** *Metallographist*, VI. (1903) pp. 64-70, 6 figs.; and *Railroad Gazette*, Aug. 8, 1902.

**RICHARDS, M. A.**—Photomicroscopy of Metals as practised by Steel Companies.

[Gives a useful account of methods in use.]

*Metallographist*, VI. (1903) pp. 71-80, 8 figs.

**SAUVEUR, A.**—On the Industrial Importance of Metallography.

*Journ. Franklin Inst.*, CLV. (1903) pp. 273-81.

**SAUVEUR, A. & H. C. BOYNTON**—Note on the Influence of the Rate of Cooling on the Structure of Steel. *Metallographist*, VI. (1903) pp. 148-55, 4 figs.



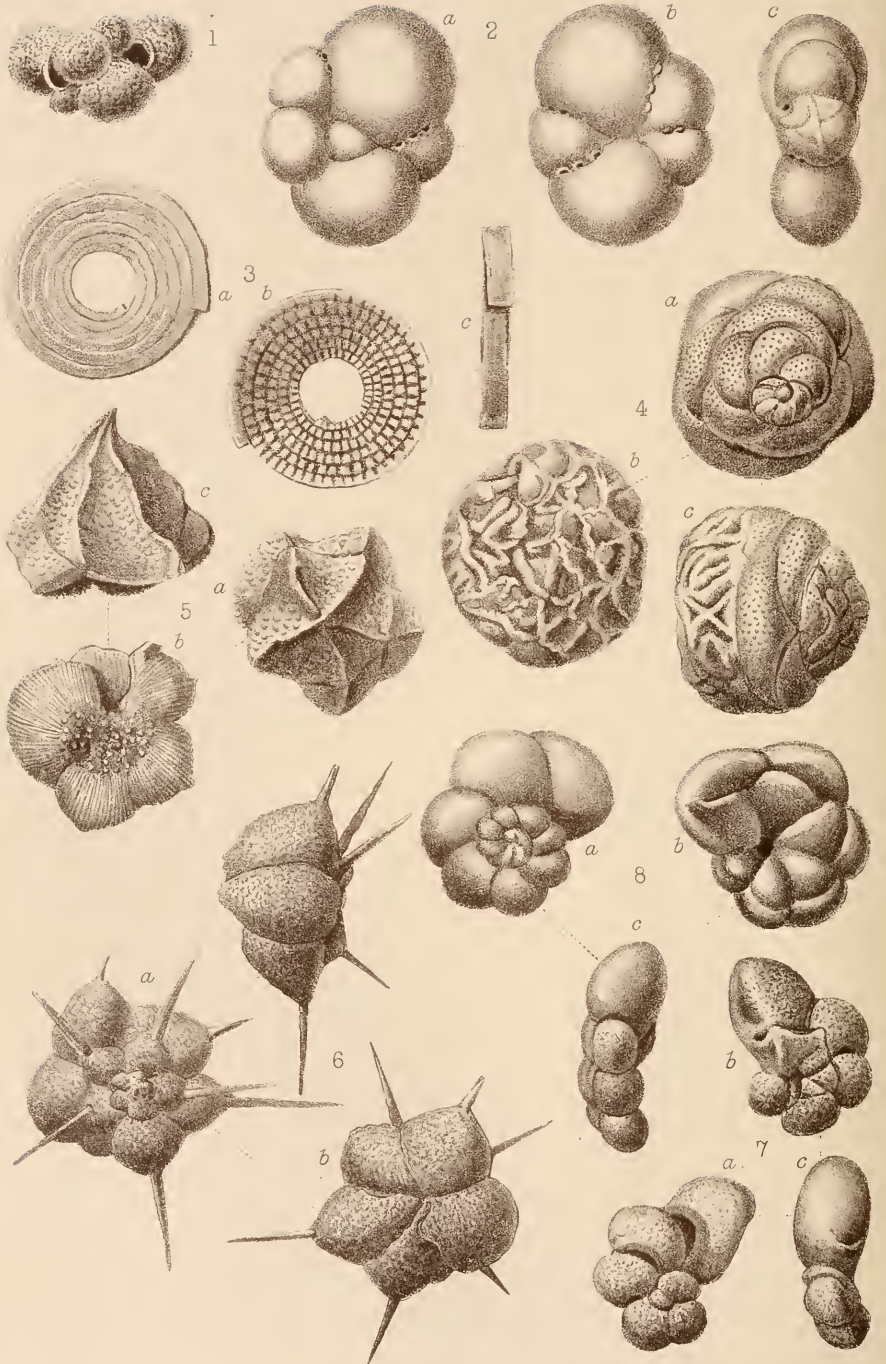

FW Millett del ad nat.

West, Newman lith.

RECENT FORAMINIFERA OF MALAY ARCHIPELAGO.



JOURNAL  
OF THE  
ROYAL MICROSCOPICAL SOCIETY.  
DECEMBER 1903.

---

TRANSACTIONS OF THE SOCIETY.

---

XII.—*Report on the Recent Foraminifera of the Malay Archipelago collected by Mr. A. Durrand, F.R.M.S.—Part XV.*

By FORTESCUE WILLIAM MILLETT, F.R.M.S.

(Read October 2nd, 1903.)

PLATE VII.

Family GLOBIGERINIDÆ.

*Globigerina* d'Orbigny.

*Globigerina bulloides* d'Orbigny.

*Globigerina bulloides* d'Orbigny, 1826, Ann. Sci. Nat., vol. vii. p. 277, No. 1; and Modèles Nos. 17 and 76. *G. bulloides* (d'Orb.) Sherborn and Chapman, 1886, Journ. R. Micr. Soc., ser. 2, vol. vi. p. 756, pl. xvi. fig. 8. *G. bulloides* (d'Orb.) Brady, Parker, and Jones, 1888, Trans. Zool. Soc., vol. xii. p. 225, pl. xlv. fig. 15. *G. bulloides* (d'Orb.) Burrows, Sherborn, and Bailey, 1890, Journ. R. Micr. Soc., p. 561, pl. xi. fig. 17. *G. bulloides* (d'Orb.) Haeusler,

EXPLANATION OF PLATE VII.

- Fig. 1.—*Globigerina helicina* d'Orbigny. × 65.  
" 2.—*Candeina nitida* d'Orbigny. × 45.  
" 3.—*Spirillina margaritifera* Williamson var. *semiornata* var. n. × 45.  
" 4.—*Cymbalopora bulloides* d'Orbigny sp. × 90.  
" 5.—*Discorbina corrugata* sp. n. × 90.  
" 6. " *imperatoria* d'Orbigny sp. × 135.  
" 7. " *rimosa* Parker and Jones. × 90.  
" 8. " *semi-marginata* d'Orbigny sp. (fide Terquem) × 90.

Note.—In all the figures the letter *a* denotes the superior aspect; *b*, the inferior aspect; and *c*, the peripheral aspect.

Dec. 16th, 1903

2 Y

1890, Abhandl. schweiz. pal. Gesell., vol. xvii. p. 118, pl. xv. fig. 46. *G. bulloides* (d'Orb.) Terrigi, 1891, Mem. R. Com. Geol. Italia, vol. iv. p. 101, pl. iii. fig. 26; and var. *triloba* (Reuss) p. 101, pl. iii. fig. 27. *G. bulloides* (d'Orb.) Silvestri, 1893, Atti e Rendic. Accad. Sci. Lett. e Arti dei Zelanti e P.P. dello Studio di Acireale, vol. v. p. 15, pl. v. figs. 59, 61, 64. *G. bulloides* (d'Orb.) Woodward and Thomas, 1893, Geol. and Nat. Hist. Survey of Minnesota, vol. iii. p. 40, pl. D, figs. 14-17. *G. bulloides* (d'Orb.) Egger, 1893, Abhandl. k. bayer. Akad. Wiss., Cl. II. vol. xviii. p. 362, pl. xiii. figs. 1-3. *G. bulloides* (d'Orb.) Goës, 1894, K. Svenska Vet.-Akad. Handl., vol. xxv. p. 83, pl. xiv. figs. 754-760. *G. bulloides* (d'Orb.) Egger, 1895, Naturhist. Ver. Passau, Jahresber. xvi. p. 36, pl. iv. fig. 13. *G. bulloides* (d'Orb.) Jones, 1896, Palæont. Soc., p. 280. *G. bulloides* (d'Orb.) Burrows and Holland, 1897, Proc. Geol. Assoc., vol. xv. p. 46, pl. ii. fig. 19. *G. bulloides* (d'Orb.) Silvestri, 1899, Mem. Pontif. Accad. Nuovi Lincei, vol. xv. p. 245, pl. iv. figs. 7-9. *G. bulloides* (d'Orb.) Fornasini, 1899, Mem. R. Accad. Sci. Ist. Bologna, ser. 5, vol. vii. p. 579, pl. i. fig. 4, pl. ii. figs. 1, 3, 5-8, pl. iv. fig. 2. *G. bulloides* (d'Orb.) Egger, 1899, Abhandl. k. bayer. Akad. Wiss., Cl. II. vol. xxi. p. 170, pl. xxi. figs. 5-7. *G. bulloides* (d'Orb.) Flint, 1899, Rep. U.S. Nat. Mus. for 1897 (1899), p. 321, pl. lxxix. fig. 2. *G. bulloides* (d'Orb.) Rhumbler, 1900, in Dr. Karl Brandt's Nordisches Plankton, Heft 14, p. 21, figs. 24-26. *G. bulloides* (d'Orb.) Chapman, 1900, Geol. Mag., n. s., dec. 4, vol. vii. pl. xiv. fig. 5. *G. bulloides* (d'Orb.) Jones and Chapman, 1900, in A Monograph of Christmas Island, p. 258, pl. xxi. fig. 17. *G. bulloides* (d'Orb.) Wright, 1900, Geol. Mag., n. s., dec. 4, vol. vii. p. 100, pl. v. fig. 18.

This cosmopolitan species occurs in considerable abundance all over the region. The examples show the usual variations of size, form, and texture, and have no special characters to distinguish them from those of other localities.

#### *Globigerina dubia* Egger.

*Globigerina dubia* Egger, 1857, Neues Jahrb. für Min., p. 281, pl. ix. figs. 7-9. Idem, 1893, Abhandl. k. bayer. Akad. Wiss., C. II. vol. xviii. p. 366, pl. xiii. figs. 36-38, 77. Idem, 1895, Naturhist. Ver. Passau, Jahresber. xvi. p. 37, pl. iv. fig. 17. *G. dubia* (Egger) Flint, 1899, Rep. U.S. Nat. Mus. for 1897 (1899), p. 322, pl. lxxix. fig. 4. *G. Eggeri* Rhumbler, 1900, in Dr. Karl Brandt's Nordisches Plankton, Heft 14, p. 19, fig. 20.

As shown by Rhumbler, there is a distinct difference between the recent specimens illustrated by Brady and Flint and the fossil example from Ortenburg figured by Egger. In these recent forms, the apertures of the chambers open directly into the umbilical

vestibule, as in *G. bulloides*. In the fossil example, the aperture is a narrow slit at the end of the last chamber, towards the central depression of the under side of the test. Following Brady's "Scheme of the genus Globigerina," the recent form must be placed in group A with *G. bulloides*, &c.; whilst Egger's fossil *G. dubia* must find a place with *G. Dutertrei* in group B.

In the Malay Archipelago, Brady's form is but little removed from *G. bulloides*, and hardly deserves separate mention. Egger's *G. dubia* scarcely differs from *G. Dutertrei*; the plan of growth is similar, and in the young specimens the aperture is large, becoming more and more constricted in the adult stage until in the thick-shelled mature examples it is reduced to a mere slit.

It will be sufficient here to record that the four varieties are represented in the Malay Archipelago, leaving the identity of *bulloides* and *Eggeri*, and of *dubia* and *Dutertrei*, an open question.

#### *Globigerina inflata* d'Orbigny.

*Globigerina inflata* d'Orbigny, 1839, Foram. Cuba, p. 134, pl. ii. figs. 7-9. *G. inflata* (d'Orb.) Balkwill and Millett, 1884, Journ. Micr., vol. iii. p. 84, pl. iv. fig. 11. *G. inflata* (d'Orb.) Terrigi, 1891, Mem. R. Com. Geol. Italia, vol. iv. p. 102, pl. iv. fig. 2. *G. inflata* (d'Orb.) Egger, 1893, Abhandl. k. bayer. Akad. Wiss., Cl. II. vol. xviii. p. 369, pl. xiii. figs. 45-47. *G. inflata* (d'Orb.) Goës, 1894, K. Svenska Vet.-Akad. Handl., vol. xxv. p. 85, pl. xiv. figs. 763-765. *G. inflata* (d'Orb.) Flint, 1899, Rep. U.S. Nat. Mus. for 1897 (1899), p. 322, pl. lxix. fig. 3. *G. inflata* (d'Orb.) Fornasini, 1899, Mem. R. Accad. Sci. Ist. Bologna, ser. 5, vol. vii. p. 577, pl. i. fig. 3. *G. inflata* (d'Orb.) Rhumbler, 1900, in Dr. Karl Brandt's Nordisches Plankton, Heft 14, p. 19, fig. 19.

This variety is not very abundant in the Malay Archipelago, but occurs at several Stations in both Areas.

#### *Globigerina rubra* d'Orbigny.

*Globigerina rubra* d'Orbigny, 1839, Foram. Cuba, p. 82, pl. iv. figs. 12-14. *G. rubra* (d'Orb.) Brady, Parker, and Jones, 1888, Trans. Zool. Soc., vol. xii. p. 225, pl. xlv. fig. 12. *G. rubra* (d'Orb.) Egger, 1893, Abhandl. k. bayer. Akad. Wiss., Cl. II. vol. xviii. p. 360, pl. xiii. figs. 42-44. *G. rubra* (d'Orb.) Silvestri, 1893, Atti e Rendic. Accad. Sci. Lett. e Arti dei Zelanti e P.P. dello Studio di Acireale, vol. v. p. 16, pl. v. figs. 62, 63, 65. *G. rubra* (d'Orb.) Goës, 1894, K. Svenska Vet.-Akad. Handl., vol. xxv. p. 85, pl. xiv. fig. 766. *G. rubra* (d'Orb.) Rhumbler, 1897, Verhandl. Deutsch. Zool. Gesellsch., p. 172, fig. 16. *G. rubra* (d'Orb.) Silvestri, 1899, Mem. Pontif. Accad. Nuovi Lincei, vol. xv. p. 262, pl. v. fig. 4. *G. rubra* (d'Orb.) Flint, 1899, Rep. U.S. Nat. Mus. for 1897 (1899),

p. 322, pl. lxxix. fig. 5. *G. rubra* (d'Orb.) Fornasini, 1899, Mem. R. Accad. Sci. Ist. Bologna, ser. 5, vol. vii. p. 580, pl. ii. fig. 11.

There are numerous examples from most of the Stations, but the individuals are insignificant, and have little to distinguish them beyond the colour.

*Globigerina conglobata* Brady.

*Globigerina conglobata* Brady, 1879, Quart. Journ. Micr. Sci., n.s., vol. xix. p. 72; and Chall. Rept., 1884, p. 603, pl. lxxx. figs. 1-5, pl. lxxxii. fig. 5. *G. conglobata* (Brady) Brady, Parker, and Jones, 1888, Trans. Zool. Soc., vol. xii. p. 225, pl. xlv. fig. 13. *G. conglobata* (Brady) Terrigi, 1889, Mem. R. Accad. Lincei, ser. 4, vol. vi. p. 114, pl. vi. fig. 14. Idem, 1891, Mem. R. Com. Geol. Italia, vol. iv. p. 102, pl. iv. fig. 3; and *G. bulloides* var. *triloba* (Reuss), p. 101, pl. iv. fig. 1. *G. conglobata* (Brady) Egger, 1893, Abhandl. k. bayer. Akad. Wiss., Cl. II. vol. xviii. p. 368, pl. xiii. figs. 55, 56. *G. conglobata* (Brady) Goës, 1894, K. Svenska Vet.-Akad. Handl., p. 86, pl. xiv. figs. 768, 769. *G. conglobata* (Brady) Flint, 1899, Rep. U.S. Nat. Mus. for 1897 (1899), p. 322, pl. lxxix. fig. 6. *G. conglobata* (Brady) Fornasini, 1899, Mem. R. Accad. Sci. Ist. Bologna, ser. 5, vol. vii. p. 582, pl. ii. figs. 12-15, pl. iii. figs. 1-5. *G. conglobata* (Brady) Chapman, 1900, Geol. Mag., dec. 4, vol. vii. pl. xiv. fig. 6. *G. conglobata* (Brady) Jones and Chapman, 1900, in A Monograph of Christmas Island, p. 234, pl. xx. fig. 3.

This form is well represented, and occurs in more or less abundance at nearly all of the Stations.

*Globigerina sacculifera* Brady.

*Globigerina sacculifera* Brady, 1877, Geol. Mag., ser. 2, vol. iv. p. 535; and Chall. Rept., 1884, p. 604, pl. lxxx. figs. 11-17, pl. lxxxii. fig. 4. ? *G. helicina* (d'Orb.) Terrigi, 1891, Mem. R. Com. Geol. Italia, vol. iv. p. 103, pl. iv. fig. 4. *G. sacculifera* (Brady) Egger, 1893, Abhandl. k. bayer. Akad. Wiss., Cl. II. vol. xviii. p. 369, pl. xiii. figs. 50-51. *G. sacculifera* (Brady) Silvestri, 1899, Mem. Pontif. Accad. Nuovi Lincei, vol. xv. p. 263, pl. v. fig. 5. *G. sacculifera* (Brady) Flint, 1899, Rep. U.S. Nat. Mus. for 1897 (1899), p. 322, pl. lxx. fig. 1.

Is very rare, and has been noted only at Station 2 in Area 1.

*Globigerina helicina* d'Orbigny, plate VII. fig. 1.

*Globigerina helicina* d'Orbigny, 1826, Ann. Sci. Nat., vol. vii. p. 277, No. 5. *G. helicina* (d'Orb.) Parker, Jones, and Brady, 1871, Ann. and Mag. Nat. Hist., ser. 4, vol. viii. p. 175, pl. xi. fig. 113.

*G. helicina* (d'Orb.) Terrigi, 1889, Mem. R. Accad. Lincei, ser. 4, vol. vi. p. 114, pl. vi. fig. 15. *G. helicina* (d'Orb.) Egger, 1893, Abhandl. k. bayer. Akad. Wiss., Cl. II. vol. xviii. p. 370, pl. xiii. fig. 52. *G. helicina* (d'Orb.) Silvestri, 1899, Mem. Pontif. Accad. Nuovi Lincei, vol. xv. p. 264, pl. v. fig. 6. *G. helicina* (d'Orb.) Fornasini, 1899, Mem. R. Accad. Sci. Ist. Bologna, ser. 5, vol. vii. p. 583, pl. iii. figs. 11, 12.

This appears to be the most unsatisfactory of all the forms assigned to the genus *Globigerina*; and, as shown by the "Planches inédites," d'Orbigny himself was not quite clear as to its characters. Brady's description of it as a "Globigerine shell of the 'rubra' type, with the addition of an inflated chamber at two opposite points of its periphery," is perhaps the best definition of the normal form; but, judging from the published figures, and the examination of actual specimens, it is frequently nothing more than an irregular aggregation of globose chambers, two or more of which exhibit an exterior arched aperture.

In the Malay Archipelago, the form is very rare; but it occurs in both areas.

Brady writes, "*Globigerina helicina* is a comparatively rare form. Occasional specimens have been met, with at nine or ten 'Challenger' Stations, scattered over the North and South Atlantic and in the South Pacific; to which may be added, on the authority of Soldani, certain points in the Mediterranean and the Adriatic." Egger reports it from nine 'Gazelle' Stations, extending from the west coast of Africa to the Fiji Islands.

#### *Globigerina æquilateralis* Brady.

*Globigerina æquilateralis* Brady, 1879, Quart. Journ. Micr. Sci., n.s., vol. xix. p. 71; and 1884, Chall. Rept., p. 605, pl. lxxx. figs. 18-21. *G. æquilateralis* (Brady) Wright, 1886, Proc. Belfast Nat. Field Club, 1884-85, App. ix., 1886, p. 332, pl. xxvii. fig. 9. *G. æquilateralis* (Brady) Chapman, 1892, Quart. Journ. Geol. Soc., vol. xlvi. p. 517, pl. xv. fig. 14. *G. æquilateralis* (Brady) Egger, 1893, Abhandl. k. bayer. Akad. Wiss., Cl. II. vol. xviii. p. 364, pl. xiii. figs. 5-8. *G. æquilateralis* (Brady) Goës, 1894, K. Svenska Vet.-Akad. Handl., vol. xxv. p. 86, pl. xiv. fig. 767. *G. æquilateralis* (Brady) Madsen, 1895, Medd. Dansk Geol. Forening, No. 2, p. 210, pl. fig. 5. *G. æquilateralis* (Brady) Chapman, 1896, Journ. R. Micr. Soc., p. 589, pl. xiii. fig. 7. *G. æquilateralis* (Brady) Silvestri, 1899, Mem. Pontif. Accad. Nuovi Lincei, vol. xv. p. 265, pl. v. fig. 8. *G. æquilateralis* (Brady) Fornasini, 1899, Mem. R. Accad. Sci. Ist. Bologna, ser. 5, vol. vii. p. 580, pl. iv. figs. 3, 4. *G. æquilateralis* (Brady) Flint, 1899, Rep. U.S. Nat. Mus. for 1897 (1899), p. 323, pl. lxx. fig. 3. *G. æquilateralis* (Brady) Rhumbler,

1900, in Dr. Karl Brandt's Nordisches Plankton, Heft 14, p. 20, figs. 21-23.

In the Malay Archipelago this planospiral form occurs at several Stations, and is moderately abundant. The examples exhibit considerable diversity of form and texture, and often closely resemble *Hastigerina pelagica*.

### *Orbulina* d'Orbigny.

#### *Orbulina universa* d'Orbigny.

*Orbulina universa* d'Orbigny, 1839, Foram. Cuba, p. 3, pl. i. fig. 1. *O. universa* (d'Orb.) Woodward and Thomas, 1885, 13th Ann. Rept. Geol. and Nat. Hist. Survey of Minnesota for 1884, p. 174, pl. iii. figs. 25-31. *O. universa* (d'Orb.) Malagoli, 1887, Boll. Soc. Geol. Italia, vol. vi. p. 522, pl. xiii. fig. 9. *Globigerina* (*Orbulina*) *universa* (d'Orb.) Idem, 1888, Atti Sci. Nat. Modena, ser. 3, vol. vii. p. 113, pl. iii. fig. 8. *O. universa* (d'Orb.) Brady, Parker, and Jones, 1888, Trans. Zool. Soc., vol. xii. p. 225, pl. xlv. figs. 7, 8, 14. *Globigerina* (*Orbulina*) *universa* (d'Orb.) Terrigi, 1889, Mem. R. Accad. Lincei, ser. 4, vol. vi. p. 114, pl. vi. figs. 16, 17. *O. universa* (d'Orb.) Mariani, 1891, Boll. Soc. Geol. Italia, vol. x. p. 729, pl. xxi. figs. 23, 24. *O. universa* (d'Orb.) Woodward and Thomas, 1893, Geol. and Nat. Hist. Survey of Minnesota, vol. iii. p. 43, pl. D, figs. 23-27. *O. universa* (d'Orb.) Egger, 1893, Abhandl. k. bayer. Akad. Wiss., Cl. II. vol. xviii. p. 374, pl. xiv. figs. 7-9, 11, 12, 39, 40. *O. universa* (d'Orb.) Fornasini, 1893, Mem. R. Accad. Sci. Ist. Bologna, ser. 5, vol. iii. p. 430, pl. ii. fig. 12. *O. universa* (d'Orb.) Silvestri, 1893, Atti e Rendic. Accad. Sci. Lett. e Arti dei Zelanti di Acireale, vol. v. p. 16. pl. ii. figs. 1-3. *O. universa* (d'Orb.) Lister, 1895, Phil. Trans., vol. clxxxvi. p. 408, figs. a-e. *O. universa* (d'Orb.) Egger, 1895, Naturhist. Ver. Passau, Jahresber. xvi. p. 38, pl. iv. figs. 18, 19. *O. universa* (d'Orb.) Rhumbler, 1897, Abhandl. Deuts. Zool. Gesell., p. 174, fig. 21. *O. universa* (d'Orb.) Silvestri, 1899, Mem. Pontif. Accad. Nuovi Lincei, vol. xv. p. 266, pl. v. figs. 11-16, 19-22. *O. universa* (d'Orb.) Flint, 1899, Rep. U.S. Nat. Mus. for 1897 (1899), p. 322, pl. lxix. fig. 1. *O. universa* (d'Orb.) Egger, 1899, Abhandl. k. bayer. Akad. Wiss., Cl. II. vol. xxi. p. 173, pl. xxi. figs. 46, 47. *O. universa* (d'Orb.) Rhumbler, 1900, in Dr. Karl Brandt's Nordisches Plankton, Heft 14, p. 27, figs. 27-30.

This form is but poorly represented in the Malay Archipelago; the examples are few and insignificant. It occurs at a small number of Stations in both Areas.

*Hastigerina* Wyville Thomson.*Hastigerina pelagica* d'Orbigny sp.

*Nonionina pelagica* d'Orbigny, 1843, Foram. Amér. Mérid., p. 27, pl. iii. figs. 13, 14. *Hastigerina Murrayi* (Wy. Thomson) Murray, 1876, Proc. Roy. Soc., vol. xxiv. p. 534, pls. xxii. xxiii. *H. pelagica* (d'Orb.) Brady, 1879, Quart. Journ. Micr. Sci., n.s., vol. xix. p. 77. *H. pelagica* (d'Orb.) Egger, 1893, Abhandl. k. bayer. Akad. Wiss., Cl. II. vol. xviii. p. 372, pl. xiii. figs. 53, 54. *H. pelagica* (d'Orb.) Flint, 1899, Rep. U.S. Nat. Mus. for 1897 (1899), p. 324, pl. lxx. fig. 4. *H. pelagica* (d'Orb.) Silvestri, 1899, Mem. Pontif. Accad. Nuovi Lincei, vol. xv. p. 273, pl. v. fig. 9. *H. pelagica* (d'Orb.) Rhumbler, 1900, in Dr. Karl Brandt's Nordisches Plankton, p. 29, fig. 31.

Of this essentially surface species, examples occur at numerous Stations in both Areas. Many of the individuals bear short spines, similar to those figured by d'Orbigny in the South American example.

*Pullenia* Parker and Jones.*Pullenia sphaeroides* d'Orbigny sp.

*Nonionina sphaeroides* d'Orbigny, 1826, Ann. Sci. Nat., vol. vii. p. 293, No. 1; Modèle No. 43. *Pullenia sphaeroides* (d'Orb. sp.) Parker and Jones, 1865, Phil. Trans., vol. clv. p. 368, pl. xiv. fig. 43. *P. bulloides* (d'Orb.) Andreae, 1884, Abhandl. geol. Special Karte Elsass-Loth., vol. ii. p. 206, pl. ix. fig. 23. *P. sphaeroides* (d'Orb.) Balkwill and Wright, 1885, Trans. R. Irish Acad., vol. xxviii. (Sci.) p. 348, pl. xii. fig. 28. *P. sphaeroides* (d'Orb.) Sherborn and Chapman, 1886, Journ. R. Micr. Soc., ser. 2, vol. vi. p. 756, pl. xvi. fig. 10. *P. sphaeroides* (d'Orb.) Brady, Parker, and Jones, 1888, Trans. Zool. Soc., vol. xii. p. 226, pl. xliii. figs. 21, 24. *P. sphaeroides* (d'Orb.) Egger, 1893, Abhandl. k. bayer. Akad. Wiss., Cl. II. vol. xviii. p. 372, pl. xix. figs. 30, 31. *P. sphaeroides* (d'Orb.) Goës, 1894, K. Svenska Vet.-Akad. Handl., vol. xxv. p. 87, pl. xiv. figs. 771, 772. *P. sphaeroides* (d'Orb.) Egger, 1895, Naturhist. Ver. Passau, Jahresber. xvi. p. 39, pl. iv. fig. 21. *P. sphaeroides* (d'Orb.) Burrows and Holland, 1897, Proc. Geol. Assoc., vol. xv. p. 47, pl. ii. fig. 20. *P. sphaeroides* (d'Orb.) Egger, 1899, Abhandl. k. bayer. Akad. Wiss., Cl. II. vol. xxi. p. 174, pl. xxi. figs. 27, 28. *P. sphaeroides* (d'Orb.) Chapman, 1900, Proc. California Acad. of Sci., ser. 3, Geol., vol. i. p. 252, pl. xxx. fig. 6.

This species is represented in the Malay Archipelago by a few insignificant specimens from Area 1.

*Pullenia obliquiloculata* Parker and Jones.

*Pullenia obliquiloculata* Parker and Jones, 1865, Phil. Trans., vol. clv. p. 368, pl. xix. fig. 4. *P. obliquiloculata* (P. and J.) Egger, 1893, Abhandl. k. bayer. Akad. Wiss., Cl. II. vol. xviii. p. 372, pl. xiii. figs. 62-64. *P. obliquiloculata* (P. and J.) Flint, 1899, Rep. U.S. Nat. Mus. for 1897 (1899), p. 324, pl. lxx. fig. 6.

This form is not uncommon at a few Stations in each of the Areas, and the examples are of the normal size.

*Sphaeroidina* d'Orbigny.*Sphaeroidina bulloides* d'Orbigny.

*Sphaeroidina bulloides* d'Orbigny, 1826, Ann. Sci. Nat., vol. vii. p. 267, No. 1; Modèle No. 65. *S. bulloides* (d'Orb.) Brady, Parker, and Jones, 1888, Trans. Zool. Soc., vol. xii. p. 226, pl. xlv. figs. 9-11. *S. bulloides* (d'Orb.) Burrows, Sherborn, and Bailey, 1890, Journ. R. Micr. Soc., p. 562, pl. xi. figs. 20, 21. *S. bulloides* (d'Orb.) Terrigi, 1891, Mem. R. Com. Geol. Italia, vol. iv. p. 104, pl. iv. fig. 6. *S. bulloides* (d'Orb.) Fornasini, 1893, Mem. R. Accad. Sci. Ist. Bologna, ser. 5, vol. iii. p. 430, pl. ii. fig. 14. *S. bulloides* (d'Orb.) Egger, 1893, Abhandl. k. bayer. Akad. Wiss., Cl. II. vol. xviii. p. 375, pl. xiii. figs. 48, 49. *S. bulloides* (d'Orb.) Goës, 1894, K. Svenska Vet.-Akad. Handl., vol. xxv. p. 87, pl. xiv. fig. 770. *S. austriaca* (d'Orb.) Egger, 1895, Naturhist. Ver. Passau, Jahresber. xvi. p. 40, pl. iv. fig. 22. *S. bulloides* (d'Orb.) Chapman, 1896, Journ. R. Micr. Soc., p. 589, pl. xiii. fig. 8. *S. bulloides* (d'Orb.) Egger, 1899, Abhandl. k. bayer. Akad. Wiss., Cl. II. vol. xxi. p. 173, pl. xxi. figs. 29, 30. *S. bulloides* (d'Orb.) Flint, 1899, Rep. U.S. Nat. Mus. for 1897 (1899), p. 325, pl. lxxi. fig. 1.

*S. bulloides* is not uncommon in the Malay Archipelago, and has been observed at most of the Stations. There is considerable variety in the aggregation of the chambers, as well as in the number of them visible externally. Whilst the majority of the examples have the usual smooth shining surface, a few show a tendency to the roughness characteristic of *S. dehiscens*, although not to such an extent as to warrant their being assigned to that species.

*Candecina* d'Orbigny.*Candecina nitida* d'Orbigny, plate VII. fig. 2.

*Candecina nitida* d'Orbigny, 1839, Foram. Cuba, p. 108, pl. ii. figs. 27, 28. *C. nitida* (d'Orb.) Egger, 1893, Abhandl. k. bayer. Akad. Wiss., Cl. II. vol. xviii. p. 373, pl. xiii. fig. 57. *C. nitida*



(d'Orb.) Flint, 1899, Rep. U.S. Nat. Mus. for 1897 (1899), p. 325, pl. lxxi. fig. 3. *C. nitida* (d'Orb.) Rhumbler, 1900, in Dr. Karl Brandt's Nordisches Plankton, Heft 14, p. 31, fig. 33.

This species is very rare in the Malay Archipelago, and has been found only in Area 2.

The example figured differs materially from the published illustrations of the species, the test being compressed rather than conical.

*C. nitida* is not so widely distributed as the other members of the Globigerinidæ to which reference has been made in this Report. Besides the localities mentioned by Brady in the 'Challenger' Report, Egger names five Stations, at all of which it is said to be rare. Flint's only Station is "near the Windward Islands."

## Family ROTALIDÆ.

### Sub-Family Spirillininæ.

#### *Spirillina* Ehrenberg.

#### *Spirillina vivipara* Ehrenberg.

*Spirillina vivipara* Ehrenberg, 1841, Abhandl. k. Akad. Wiss. Berlin, p. 422, pl. iii. VII. fig. 41. *S. vivipara* (Ehren.) Bütschli, 1886, Morph. Jahrb., vol. xi. p. 84, pl. vi. fig. 12. *S. vivipara* (Ehren.) Egger, 1893, Abhandl. k. bayer. Akad. Wiss., Cl. II. vol. xviii. p. 394, pl. xviii. figs. 56-58; and Ibid., 1899, vol. xxi. p. 18, pl. i. figs. 50, 51. *S. vivipara* (Ehren.) Flint, 1899, Rep. U.S. Nat. Mus. for 1897 (1899), p. 326, pl. lxxi. fig. 4.

This cosmopolitan species is abundant in the Malay Archipelago, and occurs at several Stations in both Areas. The individuals are normal in character, and vary but little in size.

#### *Spirillina inæqualis* Brady.

*Spirillina inæqualis* Brady, 1879, Quart. Journ. Micr. Sci., n.s., vol. xix. p. 278, pl. viii. fig. 25. *S. inæqualis* (Brady) Egger, 1893, Abhandl. k. bayer. Akad. Wiss., Cl. II. vol. xviii. p. 394, pl. xviii. figs. 40-42.

This variety is very rare in the Malay Archipelago, and has been observed only at Station 2, in Area 1.

Brady states that it has been found in shallow-water dredgings from several of the island groups of the Pacific; the depths ranging from 12 to 155 fathoms. Egger reports it from two 'Gazelle' Stations: Mauritius, 225 fathoms, and West Australia, 196 fathoms.

*Spirillina limbata* Brady.

*Spirillina limbata* Brady, 1879, Quart. Journ. Micr. Sci., n.s., vol. xix. p. 278, pl. viii. fig. 26. *S. limbata* (Brady) Egger, 1893, Abhandl. k. bayer. Akad. Wiss., Cl. II. vol. xviii. p. 395, pl. xviii. figs. 43, 44. *S. limbata* (Brady) Flint, 1899, Rep. U.S. Nat. Mus. for 1897 (1899), p. 326, pl. lxxi. fig. 5.

*S. limbata*—as represented by the form having a square periphery, and the faces plane, with limbate sutures, but without tubercles—is rare and poor in the Malay Archipelago, and has been noted only at Stations No. 2 and No. 22.

Brady names thirteen localities for the species, widely apart; Egger records it from four 'Gazelle' Stations; and Siddall has found it in the Estuary of the Dee. The 'Albatross' Station from which Flint procured it has not been recorded.

*Spirillina limbata* var. *denticulata* Brady.

*Spirillina limbata* var. *denticulata* Brady, 1884, Chall. Rept., p. 632, pl. lxxxv. fig. 17. *S. limbata denticulata* (Brady) Egger, 1893, Abhandl. k. bayer. Akad. Wiss., Cl. II. vol. xviii. p. 396, pl. xviii. fig. 66.

This variety also is very rare, and has been found only in the material from Station 17.

The Stations recorded by Brady are: East Monceour Island, Bass Strait, 38 fathoms; Raine Island, Torres Strait, 155 fathoms; and Nares Harbour, Admiralty Islands, 17 fathoms. The solitary 'Gazelle' Station is at Kerguelen, 57 fathoms.

In the Tertiary beds of St. Erth, Cornwall, a modification of this variety occurs; in which, whilst one face is in all respects similar to those of *denticulata*, the other is covered with tubercles, and the suture is not apparent.

*Spirillina margaritifera* Williamson var. *semiornata* var. n.,  
plate VII. fig. 3.

Test, inequilateral; convolutions, numerous; peripheral edge, square. One of the lateral faces flat and smooth, with the spiral suture excavated; the opposite face concave, and ornamented with a single row of tubercles arranged closely together in a spiral line. Diameter 0.60 mm.

Williamson's knowledge of *Spirillina margaritifera* was derived from a single specimen from an unknown locality, and, as he justly states, "any species founded on a single specimen can

only be accepted as a provisional one awaiting further elucidation."\*

It cannot be said that subsequent researches have altogether settled the characters of the species. The *S. tuberculata* of Brady † is very doubtfully distinct; on this point Wright observes, ‡ "The specimens recorded as *Spirillina tuberculata*, both by Siddall, in 'Memoir on the Foraminifera of the Estuary of the Dee,' and by Balkwill and myself, in 'Foraminifera of Dublin Bay and Irish Sea,' should I feel satisfied be referred to *S. margaritifera*; and *S. tuberculata* should be no longer included among the British species." And Brady himself writes, § "I am by no means confident that this form, or at any rate the British specimens that have been assigned to it, can be separated from *Sp. margaritifera*." Concerning these inequilateral forms of *Spirillina*, Chapman observes, || "The inequilateral modifications of *Spirillinae* are not unfrequent at Funafuti, and are of much interest since they point to the rotaline affinities which the genus has towards shells of the trochoid type."

Of published figures resembling or identical with *S. margaritifera*, may be mentioned:—*S. margaritifera* Terquem (not Williamson) ¶; this has a square periphery, and concave faces with two rows of tubercles. *S. nodosa* Terquem,\*\* in which there is a single row of nodosities; he remarks that this species is sometimes inequilateral, and shows one of the faces nearly plane with the nodosities less pronounced. *S. nodifera* Terquem, †† which is slightly concave in the centre, angular at the periphery, and ornamented with one series of granulations. *S. tuberculata-limbata* Chapman, ‡‡ has the larger and flat surface limbate, and the peripheral edge of the coil sharp on that side; the smaller face is slightly rounded and strongly tuberculate.

The variety *semiornata* is very rare in the Malay Archipelago, and has been noted only at Station 22 in Area 2.

### *Spirillina decorata* Brady.

*Spirillina decorata* Brady, 1884, Chall. Rept., p. 633, pl. lxxxv. figs. 22–25. *S. decorata* (Brady) Egger, 1893, Abhandl. k. bayer. Akad. Wiss., Cl. II. vol. xviii. p. 394, pl. xviii. figs. 64, 65.

This also is very rare in the Malay Archipelago, and has been found only at Station 2 in Area 1.

\* Rec. Foram. Gt. Britain, 1858, p. 93.

† Quart. Journ. Micr. Sci., n.s., vol. xix. 1879, p. 279, pl. viii. fig. 28.

‡ Proc. Belfast Nat. Field Club, App. 1885, 1886, p. 321.

§ Journ. R. Micr. Soc., 1887, p. 918.

|| Journ. Linn. Soc., vol. xxviii. 1901, p. 411.

¶ Anim. Plage de Dunkerque, part 3, 1881, p. 110, pl. xiii. fig. 2.

\*\* Op. cit., fig. 1.

†† Mém. Soc. géol. Fr., sér. 3, vol. ii. 1882, p. 34, pl. ix. fig. 32.

‡‡ Journ. Linn. Soc., vol. xxviii. 1900, p. 11, pl. i. fig. 8.

Brady names three points at which it has been obtained in the North Atlantic, one point in the South Atlantic, and three points in the South Pacific; the depths varying from 6 to 1125 fathoms. There are three 'Gazelle' Stations, West Africa, Mauritius and West Australia, at depths from 196 to 371 fathoms.

### Sub-Family *Rotalinæ*.

#### *Patellina* Williamson.

##### *Patellina corrugata* Williamson.

*Patellina corrugata* Williamson, 1858, Rec. Foram. Gt. Britain, p. 46, pl. iii. figs. 86-89. *P. corrugata* (Will.) Terquem, 1875, Anim. Plage de Dunkerque, pt. 1, p. 31, pl. iv. fig. 3; and *P. punctata* Ibid., 1881, pt. 3, p. 128, pl. xvi. fig. 9. *P. corrugata* (Will.) Egger, 1893, Abhandl. k. bayer. Akad. Wiss., Cl. II. vol. xviii. p. 393, pl. xv. figs. 70-72. *P. corrugata* (Will.) Schaudinn, 1895, Sitzungsber. Gesell. Naturforsch. Freunde zu Berlin, No. 10, p. 181, fig. *P. corrugata* (Will.) Schlumberger, 1896, Feuille Jeunes Nat., sér. 3, Ann. xxvi. p. 129, fig. *P. corrugata* (Will.) Wright, 1900, Geol. Mag., n.s., dec. 4, vol. vii. p. 100, pl. v. fig. 20.

*P. corrugata* in the Malay Archipelago is rather scarce, but there are examples from Stations in each Area.

In the living condition its distribution is world-wide, but as a fossil it is rare; and it may be worthy of mention that it is abundant in the Tertiary beds of St. Erth, Cornwall.

#### *Cymbalopora* Hagenow.

##### *Cymbalopora Poeyi* d'Orbigny sp.

*Rotalia squamosa* d'Orbigny, 1826, Ann. Sci. Nat., vol. vii. p. 272, No. 8. *Rosalina Poeyi* d'Orbigny, 1839, Foram. Cuba, p. 92, pl. iii. figs. 18-20. *Cymbalopora (Rosalina) Poeyi* (d'Orb.) Carpenter, 1862, Introd. Foram., p. 215, pl. xiii. figs. 10-12. *C. Poeyi* (d'Orb.) Brady, Parker, and Jones, 1888, Trans. Zool. Soc., vol. xii. p. 226, pl. xlvi. fig. 12. *C. Poeyi* (d'Orb.) Egger, 1893, Abhandl. k. bayer. Akad. Wiss., Cl. II. vol. xviii. p. 381, pl. xviii. figs. 51, 52; and Ibid., 1899, p. 167, pl. xix. figs. 28-30. *C. Poeyi* (d'Orb.) Silvestri, 1899, Mem. Pontif. Accad. Nuovi Lincei, vol. xv. p. 280, pl. vi. fig. 3. *C. Poeyi* (d'Orb.) Flint, 1899, Rep. U.S. Nat. Mus. for 1897 (1899), p. 326, pl. lxxii. fig. 1.

This species occurs in great abundance all over the region, and the examples exhibit great variety of form, but the trivial characters are retained throughout, and they show no tendency to coalesce with any allied forms.

*Cymbalopora tabellæformis* Brady.

*Cymbalopora tabellæformis* Brady, 1884, Chall. Rept., p. 637, pl. cii. figs. 15-18. *C. tabellæformis* (Brady) Egger, 1893, Abhandl. k. bayer. Akad. Wiss., Cl. II. vol. xviii. p. 382, pl. xviii. figs. 54, 55.

Although this is a very distinct form, and easily recognised, it seems to have escaped the notice of authors generally, and has been figured only by Brady and Egger.

In the Malay Archipelago it is rare, but it has been noted at two Stations in each Area.

Brady says that it is a coral-reef species, and all the Stations at which it occurs, recorded by him, are in the Pacific and Indian Oceans. The solitary 'Gazelle' Station is Mauritius.

*Cymbalopora bulloides* d'Orbigny sp., plate VII. fig. 4.

*Rosalina bulloides* d'Orbigny, 1839, Foram. Cuba, p. 104, pl. iii. figs. 2-5. *Cymbalopora bulloides* (d'Orb.) Carpenter, 1862, Introd. Foram., p. 216. *Discorbina bulloides* (d'Orb.) Goës, 1882, K. Svenska Vet.-Akad. Handl., vol. xix. p. 106, pl. viii. figs. 262, 263. *C. bulloides* (d'Orb.) Egger, 1893, Abhandl. k. bayer. Akad. Wiss., Cl. II. vol. xviii. p. 381, pl. xviii. fig. 53. *C. bulloides* (d'Orb.) Earland, 1902, Journ. Quekett Micro. Club, ser. 2, vol. viii. p. 309, pl. xvi. figs. 6-9.

The structure of the balloon-chamber, characteristic of this species, with its internal float, has been recently so thoroughly worked out by Earland, that it will suffice here to call attention to his paper on the subject in the Journal of the Quekett Club referred to above.

The species is well represented in the Malay Archipelago and occurs at many Stations, but is most abundant in Area 1. The examples vary considerably in form, some being as flat as a watch-case whilst others equal in height any of those figured by Möbius or Goës.

Still more numerous is an interesting variety in which the balloon-chamber is always much wrinkled, and is apparently devoid of pores or internal tube. This variety is never depressed, and seldom varies from the contour shown in the figure. Like the normal form it is most abundant at the Stations in Area 1.

*Discorbina* Parker and Jones.

*Discorbina turbo* d'Orbigny sp.

*Rotalia (Trochulina) turbo* d'Orbigny, 1826, Ann. Sci. Nat., vol. vii. p. 274, No. 39; Modèle No. 73. *Discorbina turbo* (d'Orb.)

Carpenter, 1862, Introd. Foram., p. 200. *D. turbo* (d'Orb.) Egger, 1893, Abhandl. k. bayer. Akad. Wiss., Cl. II. vol. xviii. p. 389, pl. xv. figs. 42-44. *D. turbo* (d'Orb.) Jones, 1895, Palæont. Soc., p. 291, pl. vii. fig. 29. *D. turbo* (d'Orb.) Chapman, 1896, Journ. R. Micr. Soc., p. 591, pl. xiii. fig. 13.

Typical examples of this species are very rare in the Malay Archipelago, but a passage-form approaching *D. rosacca* is very common in Area 2.

*Discorbina globularis* d'Orbigny sp.

*Rosalina globularis* d'Orbigny, 1826, Ann. Sci. Nat., vol. vii. p. 271, pl. xiii. figs. 1-4; Modèle No. 69. *Discorbina turbo* var. *globularis* Carpenter, 1862, Introd. Foram., p. 204, pl. iii. fig. 1. *D. globularis* (d'Orb.) Brady, Parker, and Jones, 1888, Trans. Zool. Soc., vol. xii. p. 226, pl. xlvi. fig. 6. *D. globularis* Egger, 1893, Abhandl. k. bayer. Akad. Wiss., Cl. II. vol. xviii. pl. xv. figs. 7-9; and *Globigerina (Rosalina) globularis* (d'Orb.), p. 365, pl. xiii. figs. 65-68. *D. globularis* (d'Orb.) Goës, 1894, K. Svenska Vet.-Akad. Handl., vol. xxv. p. 94, pl. xv. fig. 793. *D. globularis* (d'Orb.) Jones, 1895, Palæont. Soc., p. 292, pl. vii. fig. 28. *D. globularis* (d'Orb.) Chapman, 1896, Journ. R. Micr. Soc., p. 590, pl. xiii. fig. 11. *D. globularis* (d'Orb.) Morton, 1897, Proc. Portland Soc. Nat. Hist., vol. ii. p. 120, pl. i. fig. 22. *D. globularis* (d'Orb.) Flint, 1899, Rep. U.S. Nat. Mus. for 1897 (1899), p. 327, pl. lxxii. fig. 2. *D. globularis* (d'Orb.) Wright, 1900, Geol. Mag., dec. 4, vol. vii. p. 100, pl. v. fig. 21. *D. globularis* (d'Orb.) Chapman, 1900, Geol. Mag., dec. 4, vol. vii. pl. xiv. fig. 8.

Occurs in abundance at nearly all the Stations in both Areas. The examples, although small, have all the characters of the species.

*Discorbina rosacca* d'Orbigny sp.

*Rotalia rosacca* d'Orbigny, 1826, Ann. Sci. Nat., vol. vii. p. 273, No. 15; Modèle No. 39. *Discorbina rosacca* (d'Orb.) Brady, 1864, Trans. Linn. Soc., vol. xxiv. p. 473, No. 69. *D. rosacca* (d'Orb.) Sherborn and Chapman, 1886, Journ. R. Micr. Soc., ser. 2, vol. vi. p. 756, pl. xvi. fig. 11. *D. rosacca* (d'Orb.) Egger, 1893, Abhandl. k. bayer. Akad. Wiss., Cl. II. vol. xviii. p. 385, pl. xv. figs. 39-41. *D. rosacca* (d'Orb.) Goës, 1894, K. Svenska Vet.-Akad. Handl., vol. xxv. p. 94, pl. xv. fig. 792. *D. rosacca* (d'Orb.) Flint, 1899, Rep. U.S. Nat. Mus. for 1897 (1899), p. 327, pl. lxxii. fig. 3.

This species also is abundant and widely distributed in the Malay Archipelago. The examples are small, and exhibit little variety of form and texture.

*Discorbina Vilardeboana* d'Orbigny sp.

*Rosalina Vilardeboana* d'Orbigny, 1843, Foram. Amér. Mérid., p. 44, pl. vi. figs. 13-15. *Discorbina Vilardeboana* (d'Orb.) Parker and Jones, 1872, Quart. Journ. Geol. Soc., vol. xxviii. p. 115. *D. Vilardeboana* (d'Orb.) Egger, 1893, Abhandl. k. bayer. Akad. Wiss., Cl. II. vol. xviii. p. 387, pl. xv. figs. 13-15. *D. Vilardeboana* (d'Orb.) Goës, 1894, K. Svenska Vet.-Akad. Handl., vol. xxv. p. 95, pl. xvi. fig. 796. *D. Vilardeboana* (d'Orb.) Chapman, 1898, Journ. R. Micr. Soc., p. 15, pl. ii. fig. 16.

This variety is still more abundant, but it is doubtful if any of the examples are sufficiently distinct from *D. rosacea* to warrant their separation from that form.

*Discorbina concinna* Brady.

*Discorbina concinna* Brady, 1884, Chall. Rept., p. 646, pl. xc. figs. 7, 8. *D. concinna* (Brady) Egger, 1893, Abhandl. k. bayer. Akad. Wiss., Cl. II. vol. xviii. p. 388, pl. xv. figs. 22-24.

This form, rare elsewhere, is very common in the Malay Archipelago, and occurs all over the region. Amongst a multitude of individuals there must of necessity be much variation, and this is here in the direction of *D. orbicularis*.

Brady enumerates seven 'Challenger' Stations where it has been found, at depths varying from 16 to 620 fathoms; to these I can add Station 185, from which there are examples in my collection.

There are three 'Gazelle' Stations at depths of from 33 to 196 fathoms. These appear to be the only records of its occurrence.

*Discorbina orbicularis* Terquem sp.

*Rosalina orbicularis* Terquem, 1876, Anim. Plage de Dunkerque, p. 75, pl. ix. fig. 4. *Discorbina orbicularis* (Terq.) Balkwill and Millett, 1884, Journ. Micr., vol. iii. p. 23, pl. iv. fig. 13. *D. orbicularis* (Terq.) Balkwill and Wright, 1885, Trans. R. Irish Acad., vol. xxviii. (Sci.) p. 349, pl. xiii. figs. 31-33. *D. orbicularis* (Terq.) Brady, Parker, and Jones, 1888, Trans. Zool. Soc., vol. xii. p. 227, pl. xlvi. fig. 1. *D. orbicularis* (Terq.) Terrigi, 1889, Mem. R. Accad. Lincei, ser. 4, vol. vi. p. 115, pl. xvii. figs. 2, 3. *D. orbicularis* (Terq.) Egger, 1893, Abhandl. k. bayer. Akad. Wiss., Cl. II. vol. xviii. p. 389, pl. xv. figs. 16-18, 76-78. *D. orbicularis* (d'Orb.) Jones, 1895, Palæont. Soc., p. 295, pl. vii. fig. 31. *D. subrotunda* (d'Orb. sp.) Fornasini, 1898, Rendic. Accad. Sci. Ist. Bologna, n.s., vol. ii. (figures in the text, after d'Orbigny).

This form is plentiful at Stations 2 and 22; and occurs also at Station 14, but in very small numbers.

*Discorbina patelliformis* Brady.

*Discorbina patelliformis* Brady, 1884, Chall. Rept., p. 647, pls. lxxxviii. fig. 3, lxxxix. fig. 1. *D. patelliformis* (Brady) Egger, 1893, Abhandl. k. bayer. Akad. Wiss., Cl. II. vol. xviii. p. 390, pl. xv. figs. 48-50.

Is not uncommon at Station 2, and occurs at Station 6, both in Area 1, but has not been observed at any other Station.

Brady states, "Is not uncommon amongst the islands of the Pacific, at depths of 6 to 150 fathoms. It has been observed also in shallow-water dredgings from the shores of Ceylon, Madagascar, the Mauritius and Malta."

The 'Gazelle' localities are Cape Verde, Mauritius, and Western Australia.

*Discorbina tabernacularis* Brady.

*Discorbina tabernacularis* Brady, 1881, Quart. Journ. Micr. Sci., n.s., vol. xxi. p. 65; and Chall. Rept., 1884, p. 648, pl. lxxxix. figs. 5-7. *D. tabernacularis* (Brady) Egger, 1893, Abhandl. k. bayer. Akad. Wiss., Cl. II. vol. xviii. p. 390, pl. xv. figs. 58-60, 79.

In the Malay Archipelago this is a very rare form, and the examples are small and thin-shelled. It occurs at Stations 2, 6 and 14, in Area 1; and at Station 17 in Area 2.

Brady says that it is a minute coral-reef species, and names several localities where it has occurred at depths of from 2 to 255 fathoms.

Egger reports it from Mauritius, 75 and 225 fathoms; and from Western Australia, 44 fathoms.

*Discorbina corrugata* sp. n., plate VII. fig. 5.

Test, conical; base, flat or concave; peripheral margin acute. A series of sharp ridges extends from the apex to the base of the test, the spaces between the ridges being excavated. The umbilical region either hollow, or filled up with granular matter beyond which are minute radiating striæ which extend to the peripheral margin. Shell-substance dense, obscuring the sutures on the superior face of the test. Diameter, 0.28 mm.

The above is an incomplete description of an interesting form, of which there are only two (more or less damaged) specimens available for examination. The polygonal shape of the superior face is, however, sufficient to distinguish it from any other species of *Discorbina*. The number of convolutions, and the form of the chambers, cannot be determined; but there are indications that the ridges mark the centre of the chambers, and that the junction of



the sutures is in the hollow between the ridges. The species partakes of the characters of both *D. patelliformis* and *D. tabernacularis*, but is distinct from either.

The examples are from Station 31, in Area 2.

*Discorbina opercularis* d'Orbigny sp.

*Rosalina opercularis* d'Orbigny, 1839, Foram. Cuba, p. 93, pl. iii. figs. 24, 25, pl. iv. fig. 1. *Discorbina opercularis* (d'Orb.) Parker and Jones, 1872, Quart. Journ. Geol. Soc., vol. xxviii. p. 114. *D. opercularis* (d'Orb.) Egger, 1893, Abhandl. k. bayer. Akad. Wiss., Cl. II. vol. xviii. p. 389, pl. xv. figs. 73-75.

This form is badly represented in the Malay Archipelago, the examples being few and insignificant. It has been noticed only at Stations 2 and 6, both in Area 1.

It is recorded by d'Orbigny from the Islands of Cuba and Martinique; by Brady from four points on the coast of Australia, at depths of from 2 fathoms to 155 fathoms; and by Egger from West Africa, Mauritius and Western Australia from 37 to 225 fathoms.

*Discorbina pulvinata* Brady.

*Discorbina pulvinata* Brady, 1884, Chall. Rept., p. 650, pl. lxxxviii. fig. 10. *D. pulvinata* (Brady) Egger, 1893, Abhandl. k. bayer. Akad. Wiss., Cl. II. vol. xviii. p. 391, pl. xv. figs. 33-35.

Of this rare form there are some rather feeble specimens from a few Stations in both Areas.

The 'Challenger' localities given by Brady are: Nares Harbour, Admiralty Islands, 17 fathoms; and off Booby Island, south of Papua, 6 to 8 fathoms. To which I can add Raine Island, 155 fathoms, from specimens in my own collection.

The sole 'Gazelle' Station is Kerguelen, 57 fathoms.

*Discorbina imperatoria* d'Orbigny sp., var. *globosa* var. n.,  
plate VII. fig. 6.

*Rosalina imperatoria* d'Orbigny, 1846, For. Foss. Vienne, p. 176, pl. x. figs. 16-18.

This variety differs from the type in several respects; the superior face is flatter, and the inferior more convex; the chambers are more inflated, and the peripheral edge less acute; the aperture is indistinct, and the radiating lines on the umbilical region are not apparent.

This is one of the characteristic forms of the Malay Archipelago,  
Dec. 16th, 1903

and occurs in vast abundance at almost every Station in both Areas.

D'Orbigny's specimens were from the Tertiary of Tarnapol, in Galicia.

*Discorbina Bertheloti* d'Orbigny sp.

*Rosalina Bertheloti* d'Orbigny, 1839, Foram. Canaries, p. 135, pl. i. figs. 28-30. *Discorbina Bertheloti* (d'Orb.) Brady, 1864, Trans. Linn. Soc., vol. xxiv. p. 469, pl. xlvi. fig. 10. *D. Bertheloti* (d'Orb.) Brady, Parker, and Jones, 1888, Trans. Zool. Soc., vol. xii. p. 227, pl. xlvi. figs. 7, 8. *D. Bertheloti* (d'Orb.) Egger, 1893, Abhandl. k. bayer. Akad. Wiss., Cl. II. vol. xviii. p. 387, pl. xv. figs. 10-12. *D. Berthelotiana* (d'Orb.) Goës, 1894, K. Svenska Vet.-Akad. Handl., vol. xxv. p. 93, pl. xv. fig. 790. *D. Bertheloti* (d'Orb.) Flint, 1899, Rep. U.S. Nat. Mus. for 1897 (1899), p. 327, pl. lxxii. fig. 4.

This widely-distributed form is very abundant in the Malay Archipelago, and occurs in profusion all over the region.

*Discorbina vesicularis* Lamarck s.p.

*Discorbites vesicularis* Lamarck, 1804, Ann. du Muséum, vol. v. p. 183; vol. viii. 1806, pl. lxii. fig. 7. *Discorbina vesicularis* (Lam.) Carpenter, 1862, Introd. Foram., p. 204, pl. xiii. figs. 2, 3. *D. vesicularis* (Lam.) Halkyard, 1889, Trans. and Ann. Rept. Manchester Micr. Soc., p. 69, pl. ii. fig. 8.

Is common in Area 1, and occurs at one or two Stations in Area 2.

*Discorbina rimosa* Parker and Jones, plate VII. fig. 7.

*Discorbina rimosa* (Parker and Jones) Carpenter, 1862, Introd. Foram., p. 205, *D. rimosa* Parker and Jones, 1865, Phil. Trans., vol. clv. pp. 385, 421, pl. xix. fig. 6.

The examples of this species are few, and rather small. It occurs at Stations 2 and 14, in Area 1; and at Station 31, in Area 2.

Parker and Jones report it as occurring from India to Australia, including Fiji, in the recent condition; and, as fossil, from the Tertiary of Grignon, &c.

*Discorbina semi-marginata* d'Orbigny sp. (fide Terquem),  
plate VII. fig. 8.

*Rotalia (Turbinulina) semi-marginata* d'Orbigny, 1826, Ann. Sci. Nat., vol. vii. p. 276, No. 53. (Figures without name or

description). Deshayes, 1824-1837, Description des Coquilles fossiles des environs de Paris, pl. cvi. figs. 16-19. *Rotalina semi-marginata* (d'Orb.) Terquem, 1882, Mém. Soc. Géol. Fr., sér. 3, vol. ii. p. 56, pl. xi. figs. 12-14.

As represented in the Malay Archipelago, this is a Rotaline form, with a thin smooth hyaline test, and provided with a well-developed series of Asterigerine umbilical chambers. It bears a strong resemblance to the *D. rimosa* of Parker and Jones, but is devoid of the chinks between the chambers characteristic of that species. It may be noted that both forms are found in the same localities, whether recent or fossil.

The only description of *D. semi-marginata* published by d'Orbigny is in the Prodrôme de Paléontologie, vol. ii. 1850, p. 407, No. 1317, "Espèce rugueuse, ovale, bordée intérieurement," which is insufficient to identify it; whilst the figure in the "Planches inédites," referred to by Terquem, has never been published. Deshayes neither names nor describes the form figured by him, consequently the first author to give a sufficient description of the species was Terquem.

In the Malay Archipelago the form occurs in great profusion at Station 12, and in smaller quantities at Station 11; both Stations being in Area 1.

*Discorbina rugosa* d'Orbigny sp.

*Rosalina rugosa* d'Orbigny, 1843, Foram. Amér. Mérid., p. 42, pl. ii. figs. 12-14. *Discorbina rugosa* (d'Orb.) Brady, 1884, Chall. Rept., p. 652, pl. lxxxvii. figs. 3, 4. *D. rugosa* (d'Orb.) Sherborn and Chapman, 1889, Journ. R. Micr. Soc., p. 487, pl. xi. fig. 33. *D. rugosa* (d'Orb.) Egger, 1893, Abhandl. k. bayer. Akad. Wiss., Cl. II. vol. xviii. p. 383, pl. xv. figs. 1-3. *D. rugosa* (d'Orb.) Chapman, 1896, Journ. R. Micr. Soc., p. 590, pl. xiii. fig. 10; and 1900, Geol. Mag., dec. 4, vol. vii. pl. xiv. fig. 9.

Examples of the form are numerous, and occur all over the region; but they are small, and the shells thin and more or less hyaline.

D'Orbigny obtained it from Patagonia. There are but two 'Challenger' Stations, both on the southern shores of Papua, 155 and 580 fathoms respectively. Egger gives numerous 'Gazelle' Stations, extending from West Africa to Fiji, at depths of from 37 to 3020 fathoms.

*Discorbina allomorphinoides* Reuss sp.

*Valvulina allomorphinoides* Reuss, 1860, Sitzungsber. k. Akad. Wiss. Wien, vol. xl. p. 223, pl. xi. fig. 6. *Discorbina allomor-*

*phinoides* (Reuss) Brady, 1884, Chall. Rept., p. 654, pl. xci. figs. 5, 8. *Valvulina allomorphinoides* (Reuss) Egger, 1899, Abhandl. k. bayer. Akad. Wiss., Cl. II. vol. xxi. p. 43, pl. ii. figs. 4, 5. *Pulvinulina allomorphinoides* (Reuss) Fornasini, 1900, Mem. R. Accad. Sci. Ist. Bologna, ser. 5, vol. viii. p. 394, fig. 44. *D. allomorphinoides* (Reuss) Chapman, 1900, Proc. California Acad. of Sci., ser. 3, Geol., vol. i. p. 253, pl. xxx. fig. 8.

This species is confined to Area 1; and the examples, although not numerous, are sufficiently characteristic.

Elsewhere it is rare in the living condition. Under the name of *Rotalina utriculata*, Terquem reported it from Dunkerque, very rare. The 'Challenger' Stations are: off the Philippine Islands, 95 fathoms; off Raine Island, 155 fathoms; and Port Jackson, 2-10 fathoms. Fornasini records a solitary specimen from the Adriatic. In my cabinet are some examples from Korea, 20-30 fathoms.

SUMMARY OF CURRENT RESEARCHES  
RELATING TO  
ZOOLOGY AND BOTANY  
(PRINCIPALLY INVERTEBRATA AND CRYPTOGAMIA),  
MICROSCOPY, ETC.\*

ZOOLOGY.

VERTEBRATA.

a. Embryology.†

**Determination of Sex.**‡—O. Schultze discusses this old problem in a rigidly scientific manner; and, after a survey of the data in regard to plants (from Cryptogams upwards), and in regard to animals (from *Hydra* to man), comes to the conclusion that the question of sex is settled during the formative period of the ova. "The ova from which we arise are formed at a time when our mother was still in the womb of our grandmother, and are therefore without exception formed rather at the cost of our grandmother than of our mother." His experiments on influencing the sex of the second generation through the nutrition of the grandmother (in mice) yielded no definite results. There seems no reason to believe that the sex of the offspring can be affected after the ovum is ripe.

**Embryology of Tumours.**§—John Beard, in an exceedingly interesting paper, expounds the following theory of tumours. A tumour is a more or less reduced, more or less incompletely differentiated, sterile Metazoan (animal) organism. It starts by the abnormal development of an aberrant or vagrant primary germ-cell, and growing under conditions unfavourable for the complete and normal differentiation of all its parts, it unfolds and develops those things for whose growth the nidus is suitable, the rest degenerating, or remaining latent. In this way it is seen that the physiological nidus accounts for the frequent "mimicry" by tumours of their surroundings. As derived from primary germ-cells, tumours are never parts of the organism in which they occur (contra

\* The Society are not intended to be denoted by the editorial "we," and they do not hold themselves responsible for the views of the authors of the papers noted, nor for any claim to novelty or otherwise made by them. The object of this part of the Journal is to present a summary of the papers *as actually published*, and to describe and illustrate Instruments, Apparatus, &c., which are either new or have not been previously described in this country.

† This section includes not only papers relating to Embryology properly so called, but also those dealing with Evolution, Development, Reproduction, and allied subjects.

‡ SB. Phys.-Med. Ges. Würzburg, No. 5 (1902) pp. 70-8.

§ Anat. Anzeig. xxiii. (1903) pp. 486-94.

Wilms), but they are its reduced sisters or brothers, identical with it in ultimate characters. They never arise from cells which at any time may be regarded as cells of the individual. Exactly as identical twins are the products of two sister or brother germ-cells, identical in ancestry from the same primitive germ-cell, and alike in all ultimate characters, so also any animal and a tumour within it—say, a sarcoma or tumour of embryonic tissue—stand in the same relations of ancestry from one primitive germ-cell, and have the same ultimate characters at the starting-point of their development. But, unlike fully developed identical twins, the individual and its tumour develop in different directions: the one upwards along the track of higher and higher organisation, the other downwards along the roadway of abnormality, of degeneration, of arrest, at times even of riot, destruction and disaster.

**Cause of Inverse Symmetry.\***—Edwin C. Conklin brings forward some indirect evidence in support of the thesis that inverse symmetry—in man, in snail, in threadworm, &c.—is due to a reversal of the polarity of the liberated ovum. Such a reversal entirely and satisfactorily explains all the phenomena of inverse symmetry in embryonic and adult stages, whereas no other explanation does this even approximately. But if the reversal of polarity at the time of maturation can bring about a total inversion of all parts of the embryo and adult, then there must be a definite localisation of germinal primordia or “Anlagen” in the egg before maturation, e.g. the substance out of which the kidney of the snail will ultimately form must be definitely localised on one side of the chief axis, and so for every other part. If the inversion of the egg at the time of maturation inverts the position of every part which develops from it, no more convincing evidence could be found that “organ-bildende Keimbezirke” are present and definitely localised in the immature egg.

**Mendelian Heredity.†**—W. Bateson calls attention to various possibilities attainable by a modification of the Mendelian method. His facts relate to the crossing of rose-comb and pea-comb poultry with single combs. His theme, in general terms, is the Mendelian heredity of three characters allelomorphic to each other.

**Embryonic Development of Mammalian Ovary and Testis.‡**—Bennet M. Allan gives a preliminary account of researches on the development of the ovary and testis of the rabbit and pig. The constituent elements of these structures in origin and development are compared; seminiferous tubules, medullary cords, and rete cords are found to be homologous. No evidence has been found favouring the theory of the early segregation of sex-cells, yet the author is not prepared to say that his work in any way tends to disprove such a theory. There are some interesting facts bearing upon questions concerning the action of trophic stimuli in embryonic development. The most striking example of this is the formation of follicles in the portion of rete tissue within the ovary, while the extra ovarian part is not so affected.

\* Anat. Anzeig., xxiii. (1903) pp. 577–88 (8 figs.).

† Proc. Cambridge Phil. Soc., xii. (1903) pp. 153–4.

‡ Biol. Bulletin, v. No. 1, pp. 55–62.

**Results of Castration in Man.\***—E. Pittard has studied thirty men belonging to the Russian religious sect of Skoptzy, founded towards the middle of the eighteenth century, in which partial or complete castration is practised.

It seems from the data (1) that the operation diminishes, or retards the growth—both absolute and relative—of the bust, the head, and the cranium in its three principal dimensions; and (2) that the operation increases or accelerates the growth—both absolute and relative—of stature, of the lower limb, of the upper limb, and probably of the ear.

**Heterotypic Maturation-Mitosis in Amphibia.†**—Thomas H. Montgomery, jun., has studied the spermatogenesis of *Plethodon cinereus* and *Desmognathus fuscus*, and comes to the conclusion that the heterotypic division really represents a reduction-division. The normal number of chromosomes is twenty-four; in the nuclei of the spermatocytes of the first order there are only twelve, which are interpreted as bivalent, arising by the end-to-end coalescence of two univalent chromosomes in a U-shaped loop. The longitudinal splitting, which occurs in these loops, corresponds to an equational-division in the second maturation-mitosis. In the first spermatocyte-division these bivalent chromosomes are divided into two univalent chromosomes, which represents a true reduction.

**Acceleration and Retardation of Metamorphosis in *Amblystoma tigrinum*.‡**—J. H. Powers has made many observations and experiments on the causes affecting metamorphoses in the tiger salamander, which is famous for its extreme variability. His facts lead him to conclude that the acceleration or retardation of metamorphosis is little, if at all, a question of enforced air-breathing, of gill development, of oxygenated or unoxygenated water, of temperature or of light. He does not deny that these important factors have their influence, but his experiments show that nutrition is the fundamental factor. Extreme acceleration results from starving, a sudden check to a rich food-supply is the common cause of early metamorphosis, a moderate but constant food-supply postpones the change. In general terms, the chief factors influencing metamorphosis are always sudden shifts in metabolism, usually, or at least most readily, induced by changes in the food-supply.

**Hybrid Nature of *Triton blasii*.§**—W. Wolterstoff has made a number of breeding experiments, which appear to prove that *Triton blasii* must be regarded as a collective title for the various hybrid-forms of *Triton cristatus* and *Triton marmoratus*. A detailed study of the progeny of "*Triton blasii*" is promised in a forthcoming volume of "Zoologica."

**Development of Lungs in *Discoglossus pictus*.||**—E. Goggio has studied the early stages in the development of the lungs in this Amphibian. He has been led to conclude that the primordium is primarily endodermic, that it is only due in part to a diverticulum of the enteric

\* Comptes Rendus, cxxxvi. (1903) pp. 1411-3.

† Biol. Bull. iv. (1903) pp. 250-69 (8 figs.) See Zool. Centralbl. x. (1903) p. 616.

‡ Amer. Naturalist, xxxvii. (1903) pp. 385-410.

§ Biol. Centralbl., xxiii. (1903) pp. 726-8.

|| Atti. Soc. Tosc. Sci. Nat., xix. (1903) pp. 239-67 (2 pls.).

wall, that it is paired and solid to start with, that the mesodermic envelope takes an active share in the growth, but that this growth is largely due to the division of the primitive cells forming the primordium.

**Comparative Embryology of the Swim-Bladder.\***—Fanny Moser points out (1) that in some fishes, e.g. *Rhodeus* and carp, the swim-bladder is constricted like an hour-glass, lies in the middle line dorsal to the gut, with a narrow pneumatic duct, which opens into the caudal region of the bladder; (2) that in another set, e.g. trout and salmon, the swim-bladder is a long narrow sack, somewhat to the left of the gut, with a wide opening entering the latter slightly to the left; and (3) that in others, such as stickleback, the swim-bladder is a wide sack, dorsal to the gut, and without pneumatic duct.

In groups (1) and (3), as von Baer and others have pointed out, the swim-bladder arises somewhat to the right of the gut; in group (2) the origin is quite dorsal, but not quite median, being again to the right. The author briefly discusses the various re-arrangements in the course of growth. His point is, that there is some measure of plasticity in the mutual relations of gut and swim-bladder, and that this takes the edge off the contrast often drawn between the dorsal origin of the swim-bladder and the ventral origin of the lungs. It will be recalled that the dorsal lung of *Ceratodus* arises from a ventral primordium.

**Early Development of Lepidosteus.†**—A. C. Eycleshymer describes the cleavage of the ovum of *Lepidosteus*, which some have described as meroblastic, others as holoblastic. It may possibly be of a heterogeneous character, but the author regards the occurrence of complete holoblastic cleavage as very improbable. A comparative study of the cleavage among the Ganoids reveals in this small group of fishes a most interesting series of transitional forms. Beginning with the holoblastic egg of *Acipenser*, which closely resembles the Amphibian egg, we pass to the modified holoblastic as exhibited by the egg of *Amia*, thence to the egg of *Lepidosteus* with its meroblastic tendencies, and from this the typical meroblastic condition of the Teleost is readily derived.

**Evolution of Vertebrate Limbs.‡**—P. le Damany discusses the familiar fact that while homologous limbs are often different in position in relation to the body, they are isotropic throughout. A young crocodile in the egg has its limbs orientated almost in the same way as in Mammals, but after the animal has begun to crawl about the original orientation disappears. The author's point is, that the embryonic orientation is adaptive to the conditions of growth within the narrow compass of the egg. In another paper § the author maintains that the torsion of bones, familiar in the ribs, is due to muscular action in the course of development.

#### b. Histology.

**Canaliculi in Ganglion Cells.¶**—Rachel Pewsner Neufeld discusses the "Saftkanälchen" in the ganglion cells of the spinal cord of the

\* *Anat. Anzeig.*, xxiii. (1903) pp. 609-11.

† *Decennial Publications*, Univ. Chicago, x. (1903) p. 17 (2 pls.).

‡ *Trav. Sci. Univ. Rennes*, i. Fasc. iii. (1902) pp. 333-8.

§ *Tom. cit.*, pp. 371-4.

¶ *Anat. Anzeig.*, xxiii. (1903) pp. 424-46 (2 pls. and 1 fig.).



white rat, etc., and their relation to the pericellular "Saftlückensystem." She finds that the intracellular canaliculi open into runnel-like lymph spaces, which lie on the surface of the cell and form depressions upon it; that the intracellular canaliculi are without walls and belong structurally to the cytoplasm of the ganglion cell; that there is no special trophospongium in the ganglion cells of the spinal cord; that the grey matter immediately surrounding the ganglion-cell is distinguishable as a clear pericellular area from more distal areas; and that the spaces and runnels on the cell-surface probably represent, along with the sap-canalliculi of the cell, the beginnings or roots of the lymph-system of the spinal cord.

**Secretory Processes in Suprarenal Capsules.\***—C. Ciaccio has studied these, in many representative types of vertebrates. The cortical and medullary areas are structurally and functionally distinct. The cortical secretion consists (*a*) of fatty and oxyphile substances, and (*b*) of a specific liquid secretion (in the median zone), and a specific granular secretion, preceded by a pre-granular stage, in the internal zone.

The medullary region has also a twofold secretion: (*a*) of basophil granules, which in part pass into the veins, and (*b*) of fuchsinophil granules. The cortex is devoted to the transformation of toxic products, while the medulla produces a substance necessary for normal metabolism.

**Formative Elastic Structures in Cells.†**—N. K. Koltzoff describes, especially in spermatozoa of Decapod Crustaceans, various elastic structures which he calls formative because they appear to determine the external form of the cell. He analyses the various factors which determine form: the internal turgor (osmotic pressure, or it may be "Quellungsdruck"), the osmotic pressure of the external medium, and surface tension. But in cases like the sperms of Decapod Crustaceans, the state of affairs is complicated by the existence of elastic fibres, and to a consideration of these the paper is especially devoted.

**Brunner's Glands.‡**—R. R. Bensley disagrees almost wholly with the conclusions of Bogomoletz in regard to the glands of Brunner. The most inexplicable of these conclusions is that which ascribes to the zymogenic gland-cell the power to take on secondarily the function of mucin-secretion.

In the rabbit, the glands of Brunner are mixed glands (well compared by Castellant to the mixed glands of the trachea) composed of mucous portions, the cells of which stain strongly in stronger muchæmatein, mucicarmine, etc.; and serous portions, the cells of which do not stain in these solutions, but, on the contrary, possess a radially striated, basal zone, containing a great deal of the nucleo proteid prozymogen, as may be demonstrated by the microchemical reaction for iron and phosphorus, and an apical zone filled with minute granules of zymogen.

\* Anat. Anzeig., xxiii. (1903) pp. 401-24 (15 figs.).

† Biol. Centralbl., xxiii. (1903) pp. 680-96 (12 figs.).

‡ Anat. Anzeig., xxiii. (1903) pp. 497-507 (3 figs.).

In all other Mammals examined up to the present, the glands of Brunner are pure mucous glands. They may secrete small quantities of enzyme, but these are not present in sufficient quantities to be demonstrable. The rabbit is unique among Mammals in possessing serous components in the glands of Brunner.

**Structure of the Outer Segments of the Rods in the Retina of Vertebrates.\***—Arthur D. Howard finds that the outer segments of the rods in the retina of the frog contain each an axial core that differs from the peripheral substance, but the exact nature of this core has not yet been made out. The outer segments, as demonstrated by the use of polarised light, are positively anisotropic, and agree in this respect with the axis cylinders of nerves. These outer segments therefore give evidence of containing longitudinal fibrillæ, and in some respects are not unlike a cross-stripped muscle fibre.

A very successful method for obtaining unwrinkled retinae is described.

#### c. General.

**Marsupial Region of Marsupialia.†**—Albertina Carlsson has made an anatomical study of this region in a representative series of Marsupials. Among the conclusions arrived at we may note: (1) that the pouch of *Echidna* is homologous with the Metatherian marsupium; (2) that there is no direct relation between the development of the pouch and that of the marsupial bones; and (3) that the absence of a *musculus sphincter marsupii*, when a pouch is present, is a degenerative condition.

**Meckel's Diverticulum and Concomitant Absence of Cæcal Appendix.‡**—Dr. Ramè describes the case of a woman whose post-mortem examination revealed the presence of a true ileal diverticulum (Meckel's diverticulum) and the absence of an appendix vermiformis. The point is that the absence of the latter, and the presence of the former, may be correlated variations.

**Phylogeny of Vomerine Bones.§**—R. Broom shows that the Mammalian vomer has its homologue in the "parasphenoid" of the Reptiles and Amphibians, and that the so-called "vomeres" of these lower forms are really homologous to the dumb-bell bone ("*prevomer*") of *Ornithorhynchus*. He discusses the steps by which the vomerine bones of the higher forms have been derived from those of their Labyrinthodont ancestors, and gives a useful table showing the principal modifications of the vomer and prevomer in the primitive Labyrinthodonts and Cotylosauria, in the Rhychocephalian phylum, in the Chelonia, and in the Theriodont phylum.

**Homology of the Lagena throughout Vertebrates.||**—H. Spencer Harrison corroborates, against Alexander and von Ebner, the orthodox

\* Amer. Naturalist, xxxvii., No. 440, pp. 541-50.

† Zool. Jahrb., xviii. (1903) pp. 489-506 (2 pls.).

‡ Trav. Sci. Univ. Rennes, i.-(1902) pp. 175-86 (3 figs.)

§ Proc. Linn. Soc. N.S.W., xxvii. (1902, published 1903) pp. 544-60 (3 pls.).

|| Anat. Anzeig. xxiii. (1903) pp. 627-34 (3 figs.).

view that the portion of the membranous auditory labyrinth which is described as the "lagena" or "lagena cochleæ," is the same structure throughout the vertebrate series. He points out what he regards as Alexander's mistakes, and supports from his own studies the result of Hasse, Retzius, and Kuhn that the lagena, which first appears in Fishes, and persists in Amphibians, Reptiles, Birds, and Mammals (without a sensory area in the last group) is the same structure throughout.

**Circulation in Labyrinth of Ear of Pig.\***—G. E. Shambaugh has worked out the circulation in the labyrinth by using Eichler's method of making celloidin casts of the labyrinth. A large series of embryos was injected, and the simpler scheme for the distribution of the vessels found in the younger embryos is utilised in interpreting the complicated system of vessels found in the labyrinth at full term. There are ten beautiful coloured plates.

**Genital Apparatus of Bats.†**—M. Rauther finds that the epididymis of Chiroptera functions as a sperm-reservoir. Seminal vesicles occur only in the Frugivora; in the Microchiroptera their place is taken by specialised glandulæ ampullorum of the vas deferens. Besides prostate and Cowper's glands, there are special urethral glands; and new complications in the penis and around the anus are described.

**Origin of the Thoroughbred Horse.‡**—Prof. Ridgeway suggests that the Barbary horse, from which all the fine horses of the world have sprung, was derived either from the zebra of North-East Africa, or, as is more likely, from some very closely allied species now extinct, which like Prezevalsky's horse may have had castors on its hind legs like *Equus caballus*.

**Ancestral Canidæ.§**—J. B. Hatcher describes a number of interesting Oligocene Canidæ recently discovered in Nebraska, and now preserved in the Carnegie Museum. A full account is given of an almost complete skeleton of *Daphænus felinus* Scott, and two new genera, *Proamphicyon* and *Protamnocyon*, are described. It is held that *Daphænus* has no known descendant, that *Proamphicyon* is ancestral to *Amphicyon*; and that *Protamnocyon* is ancestral to *Tamnocyon*. This last animal is of particular interest as ancestral to *Canis*, and the discovery of *Protamnocyon* carries the known ancestry of the dog one stage further back.

**Perforation of a Vein by an Artery in the Cat.||**—Arthur W. Weisse describes an interesting case in which the right common iliac vein shows a slit through which the superior gluteal artery passes. Various similar abnormalities are on record, and can only be explained by reference to the development. It seems probable that the internal iliac artery grows out from the dorsal aorta before the common iliac vein develops from the inferior vena cava. If this should prove to be so, we can readily see that the primordium of the vein on coming in contact with the artery, or in this case with its superior gluteal branch, might

\* Decennial Publications, Univ. Chicago, x. series 1, p. 20 (10 pls.).

† Anat. Anzeig., xxiii. (1903) pp. 508-24 (5 figs.).

‡ Proc. Cambridge Phil. Soc., xii. (1903) pp. 141-3.

§ Mem. Carnegie Museum, i. pp. 65-108 (7 pls.). See Amer. Naturalist, xxxvii. (1903) pp. 498-9.

|| Amer. Naturalist, xxxvii. (1903) pp. 489-92 (1 fig.).

occasionally grow entirely around it instead of passing to one side. The fact that in the case recorded and figured, the right superior gluteal artery arises from the internal iliac much farther forward than is usual, and so comes to be directly in the course of the right common iliac vein, would seem to bear out this suggestion.

**Albinism in Birds and Mammals.\***—T. Bézier discusses cases of albino rooks, magpies, swallows, thrushes, shrews, &c.; he finds that out of 18 cases of birds, nine were complete albinos and nine incomplete, while out of 7 cases of Mammals, six were complete albinos and one incomplete.

**Adaptations to Molluscivorous Diet in *Varanus niloticus*.†**—Einar Lönnberg finds that this lizard in Kameroun feeds to a great extent on land-molluscs, dropping or shaking off the fragments of shell before it swallows the animal. The development of the powerful jaws and large molars of this species is interpreted as a special adaptation to the habit of devouring large and hard-shelled snails. This is illustrated in detail by comparing the skulls of *V. niloticus* with *V. salvator*. Some adaptations in the alimentary tract are also recorded. Whether the Lamarckian or the selectionist interpretation be accepted, the indisputable fact remains that we have in this snail-eating lizard a remarkable adaptation to a peculiar diet.

**Structure of Gecko's Toes.‡**—Julius Tandler notes that the numerous investigations on this subject have been confined to the structure of the cutis and epidermis, without attention to the skeletal parts, the musculature, and the vascular arrangements. He has filled this gap by his studies on *Ptyodactylus lobatus* and *Platydactylus annularis*, and shows in particular that the remarkable powers of adhesion which the Geckos display become more intelligible when the muscular and vascular details are carefully considered. Apart from the adhesion of the fine lamellæ, there is a vacuum-action due to the remarkable muscular and vascular arrangements. But it is not easy to state very briefly how these arrangements work.

**Muscles of Mastication in Lacertilia.§**—O. Charnock Bradley has given his attention to a subject in regard to which but little has hitherto been known, the muscles of mastication and the movement of the skull associated with the act of mastication in lizards. His studies were chiefly based on *Varanus bivittatus*, but the musculature in other forms is also referred to. Some of the comparisons bring out facts of special interest, e.g. the absence of the deep-seated muscles of mastication in the Chamæleon.

**Phylogeny of Chelonians.||**—Louis Dollo describes a new Eocene tortoise—*Eochelone brabantica* n. g. et sp.—a type of much systematic interest. The position and structure of its choanæ explain the origin of

\* Trav. Sci. Univ. Rennes, i. (1902) pp. 191-4.

† Arkiv. Zool. Svensk. Vetenskapsacad., i. (1903) pp. 65-83 (5 figs.).

‡ Zeitschr. Wiss. Zool., lxxv. (1903) pp. 308-26 (2 pls.).

§ Zool. Jahrb., xviii. (1903) pp. 475-88 (1 pl.).

|| Bull. Sci. Acad. Roy. Belgique, No. 8 (1903) pp. 792-801.

the peculiar choanæ of *Dermochelys coriacea*, and throw light on the evolution of the Athecæ from the marine Thecophora.

In a subsequent essay\* Dollo discusses the origin of *Dermochelys*, and seeks to interpret the osteology of Chelonians in terms of the myology and ethology. He tries to realise the ethology of the extinct types, and discusses the geographical and stratigraphical distribution, and the classification of Chelonia. He uses his results as a basis for some general ætiological suggestions.

**Classification of Trionychidæ.**†—Fr. Siebenrock takes a survey of this family of Chelonians, and uses the structure of the various parts of the plastron as a basis for a revised classification. He also describes ‡ *Cyclanorbis oligotylus* sp. n. In another paper he revises the classification of the species of *Podocnemis*.

**Origin of Poison Glands in the Land Salamander.**§—M. Phisalix finds that the first appearance of the cutaneous glands is not due to a proliferation of the cells of the deep layer of the epidermis; it is in the dermis, under the basal layer of the epidermis, that the first rudiments of the poison glands appear. They are thus mesodermic in origin, and connections with the ectoderm and the formation of their ducts constitute secondary phenomena.

**Sense of Hearing in Fishes.**||—G. H. Parker shows that the common killifish, *Fundulus heteroclitus*, does actually hear sounds made by tuning-forks, and that it becomes deaf if the auditory nerve be cut.

The lateral line is closely associated with the ear, and may also assist in hearing. In the skin, the lateral line, and the ear, we are dealing with what may be called three generations of sense-organs; the skin representing the first generation, and giving rise to the lateral line organs, the second, which in turn produce the ears.

**Change of Colour in Trout.**¶—Albert Schöndorff has made many experiments, and comes to the following conclusions. The colour-change is wholly due to the persistent migration of the chromatophores and to their expansion or contraction. The chief factor is the influence of illumination; a direct nervous rôle was not proved.

In the trout there are only two kinds of pigment, namely, melanins and lipochromes. The former occur in rods, and are intracellular; the latter are amorphous and extracellular. In the chromatophores the pigment-cells and their processes form a structural and functional unity, that is to say, the melanin-rays are processes of the pigment-cells, and disappear when the latter contract.

The author contradicts the conclusion that no pigment-cells occur in the epidermis. His figures show that apart from processes the bodies of the pigment-cells occur in the epidermis. The origin of the epidermic

\* Tom. cit., pp. 801-50.

† SB. k. Akad. Wiss. Wien, exi. (1902) pp. 807-46 (18 figs.).

‡ Tom. cit., pp. 157-70 (1 pl.).

§ Arch. Zool. Expér., series 4, i. (1903). Notes et Revue, No. 8, pp. cxxvi-cxl.

|| Bull. U.S. Fish Commission for 1902, pp. 45-64 (1 pl.). See Amer. Naturalist, xxxvii. (1903) pp. 499-500.

¶ Arch. Naturges., lxi. (1903) pp. 399-426 (1 pl.).

pigment seems to be exogenous not "autochthonous," for the young trout show clearly an invasion of the epidermis from the cutis. As to the chemical nature of the pigments, Krukenberg's results are corroborated.

**Resistance of *Gasterosteus aculeatus* to the Osmotic Pressure of different Media.\***—M. Siedlecki has subjected specimens of *G. aculeatus* to solutions in various degrees of concentration of sugar, glycerine, potassium chloride, sodium chloride, sodium sulphate, &c., and finds that they show resistance to a high degree of osmotic pressure. He considers that the epithelium of the body and gills acts as a semipermeable membrane to certain substances; when the epithelial layer is partly disintegrated the resistance is so diminished that the animals succumb rapidly even in weak solutions.

**Gill-Filters of Freshwater Fishes.†**—Enoch Zander gives a careful account of the "sieve-processes" which occur on the edges, or only on the anterior edge of the branchial arches. They differ greatly in form, number and disposition, and Zander connects the manifold arrangements with the nature of the food. In predatory fishes, like pike and burbot, the sieve-processes are absent or very primitive, while the cavity of the mouth and pharynx bears pointed teeth for gripping the prey; but fishes which feed on small organisms, which grub in the mud, and so on, have a fine filter between the gill-clefts. In general, Zander's results agree with what Arnold has noted in regard to the same subject, but the detailed illustrations are of much interest.

**Palæospondylus.‡**—W. J. Sollas and Igera B. J. Sollas have investigated this fossil by means of serial sections, showing that the substance of which the fossil consists is a true coal. "The organism was evidently a primitive fish, with some features which are suggestive of Marsipobranchs, some of Elasmobranchs, and some of young Dipnoi or larval Amphibians; after branching off from the Piscine stem, at a point below the origin of the Elasmobranchs, it pursued an independent course of development."

**Appendages of *Tremataspis*.§**—W. Patten concludes a detailed argument with the statement that we are justified in crediting *Tremataspis* with a pair of oar-like swimming appendages—probably attached to the largest pair of incisions on the anterior ventral margin of the head—similar to those of *Bothriolepis* and *Pterichthys*. Similar appendages were probably present in *Pteraspis*, *Cyathaspis* and *Tolypaspis*.

That by far the greater share of the work of locomotion in the Ostracoderms must have been performed by the oar-like cephalic appendages, is indicated by their anterior position and great size in *Bothriolepis* and *Pterichthys*, and by the relatively small size of dorsal and caudal fins in the latter genus. Such a condition is in marked contrast to that in many of the most primitive of the true fishes, where

\* Comptes Rendus, cxxxvii. pp. 469-71.

† Zeitschr. Wiss. Zool., lxxv. (1903) pp. 233-57 (17 figs.).

‡ Proc. Roy. Soc., London, lxxii. (1903) pp. 98-9.

§ Amer. Naturalist, xxxvii. (1903) pp. 223-42 (9 figs.).

the pectorals are much smaller relatively, serving rather as balancers, the principal work of locomotion being performed by the tail and caudal fin.

Among true Vertebrates, the only structures suggestive of the cephalic appendages of the Ostracoderms are the external gills during their early embryonic stages, including among these structures the "balancers" of Amphibian larvæ. The large size and anterior position of the latter appendages make them especially suggestive of the oar-like appendages of *Tremataspis*.

**Peculiar Modification in Permian Dipnoans.\***—C. R. Eastman describes a species of *Sagenodus* (*S. pertenuis* sp. n.), which occupies a unique position amongst fossil Dipnoans in having a dentition adapted for cutting instead of crushing, thus paralleling the conditions found in certain Palæozoic sharks and in recent Gymnodonta. It may be plausibly associated with the change from marine to brackish-water conditions that took place during the Permian. A sharp cutting edge is developed, and the author is struck by the fact that in the aberrant series of *Edestus*-like sharks, that flourished contemporaneously, a similar departure occurs. In two of the most conservative and persistent groups of fishes, namely the Ceratodonts and Cestracionts—both of which have had a continuous existence ever since the Permian—the extreme of variation was attained toward the close of the Palæozoic. Another interesting feature to be brought forward in connection with *Sagenodus pertenuis* is its apparently wide distribution (e.g. in Russia as well as Texas). Bearing in mind the world-wide scattering of the *Edestus* series that took place during the late Palæozoic, Eastman notes that the stimulus which quickened variation and distribution was responded to simultaneously by the two groups of fishes exceeding all others in longevity, after which they relapsed into sluggishness.

**Lost Atlantis.†**—R. F. Scharff has studied the land and freshwater faunas of the Canary Islands, Madeira and the Azores, and comes to conclusions very different from those of Wallace. There may have been colonisation of these islands by animals transported by winds and currents, but a large percentage of the fauna indicate connection with present continents.

He maintains that "Madeira and the Azores, up to Miocene times, were connected with Portugal; and that from Morocco to the Canary Islands, and from them to South America, stretched a vast land which extended southward certainly as far as St. Helena. This great continent may have existed already in Secondary times, as Dr. Jhering suggested; and it probably began to subside in early Tertiary times." Scharff believes that the northern portions of this Lost Atlantis persisted until the Miocene, and that subsequently, in early Pleistocene, there was again a connection of the Atlantic islands with the Mediterranean countries (Africa and Europe). These ideas agree with those of A. E. Ortmann, at least as far as they admit the connection of West Africa with South America.

\* Amer. Naturalist, xxxvii. (1903) pp. 493-5 (2 figs.).

† Proc. R. Irish Acad., xxiv. (1903) pp. 268-302.

**Bermuda Islands.\***—Addison E. Verrill gives an account of these islands—dealing with physiography, meteorology, products, fauna and flora. He discusses many subjects of great interest in connection with the changes of the fauna and flora for which man is responsible: e.g. the effects of hogs and wood-rats, of de-forestation, of introductions and eliminations. He deals with the extermination or partial extermination of native birds, the partial extermination of the whales, the extermination of breeding sea-turtles, the decrease of certain fishes and molluscs, the introduction of all sorts of animals from rats to earthworms. The whole story is one of great ætiological as well as practical interest.

### INVERTEBRATA.

**Microscopic Freshwater Animals of Balaton.†**—E. von Daday gives a list of 209 microscopic freshwater animals obtained in the survey of the freshwater basins around Balaton. They range from Protozoa to Arachnoidea, and include several new species, and notably the new Cladoceran genus *Wlassicsia*.

#### Mollusca.

##### a. Cephalopoda.

**Remarkable Young Form of Cephalopod.‡**—C. Chun describes some small Decapods, from 1 mm.—10 mm. (including extended tentacles) in length, in which two of the tentacles have fused throughout their entire length to form a proboscis-like process. No hint of this has been seen in any Decapod; it must be a juvenile character—probably, however, of a hitherto unknown genus. The name *Rhynchoteuthis* is proposed.

**Statocysts of Cephalopods.§**—R. Hamlyn-Harris gives a detailed description of the large and highly evolved statocysts of Cephalopods. Besides the well-known principal macula statica—the relatively large sensory terminal plate on which the statolith rests—the author has found two other maculae, which he calls macula neglecta, anterior and posterior. After describing the general structure in representative types of Octopods and Decapods, the author gives an account of the minute structure, and contributes a few embryological notes.

**Loligo media.||**—L. Joubin figures a series of this small pelagic squid, which has received many specific names. He seeks to show that the numerous synonyms refer to different growth-stages of the same animal. The growth changes differ according to the sex, and the sexual differences penetrate even into the ‘pen,’ which is relatively shorter in the females.

**Hetroteuthis weberi.¶**—L. Joubin describes this new species from the Dutch “Siboga” expedition. It differs from *H. dispar*, the only other known species of the genus, in being relatively shorter and broader, in having shorter arms with the suckers touching, in having a larger fin

\* Trans. Connecticut Acad., xi. (Centennial vol.) Part II. (1901–2) pp. x. and 413–956, pls. lxx–civ.

† Zool. Jahrb., xix. Heft i. (1903) pp. 37–98 (2 pls. and 3 figs.).

‡ Zool. Anzeig., xxvi. (1903) pp. 716–17 (3 figs.).

§ Zool. Jahrb., xviii. (1903) pp. 327–58 (5 pls. and 10 figs.).

|| Trav. Sci. Univ. Rennes, i. (1902) pp. 165–9 (1 photograph).

¶ Trav. Sci. Univ. Rennes, i. Fasc. iii. (1902) pp. 361–4 (4 figs.).



attached higher up, &c. Remarkable is the difference in locality, for while *H. dispar* is Mediterranean, the new species came from the Dutch Indies.

**Spermatogenesis in Cephalopods.\***—Curt Thesing describes the differentiation of the spermatid into the spermatozoon in *Octopus*, paying particular attention to the history of the central corpuscles, two of which are always present. In various Cephalopods—*Rossia macrosoma*, *Sepia officinalis*, and *Loligo vulgaris*—the author has studied the occurrence of nutritive cells. He did not find what Pictet called a cytophore, but nutritive cells play an important rôle. Some spermatogonia, spermatocytes, and even spermatids and spermatozoa, seem to degenerate; the cell boundaries become indistinct and the nuclei are dissolved; a syncytium is formed. Into such syncytia the normal spermatozoa force their heads, and apparently utilise the material. In follicles which contain relatively few sperm-cells, the syncytia tend to be rounded off, producing the appearance which Pictet described as a cytophore.

#### γ. Gastropoda.

**New Solenogastres.†**—H. F. Nierstrasz describes *Chatoderma challengerii* sp. n., which, in its distichal radula and its quite incipient mid-gut gland, &c., appears to be primitive, and in some respects a transition-form between Neomenidæ and Chatodermatidæ. Except that it was got on the "Challenger" expedition, the origin of the specimen is unknown. Another form, *Chatoderma normanni* n. sp., given by Canon Norman to the Utrecht Zoological Laboratory, but also of unknown locality, lies near *Ch. loveni*; and a third new species *Ch. canadense* is nearly related to *Ch. nitidulum*.

The author establishes a new genus, *Uncimemia* (*U. neapolitana*), for a form from Naples which is in some ways near *Paramenia*. It is distinguished from other Neomenidæ by the absence of radula and radulasac, by the presence of an organ of unknown function around the fore-gut, of two ventral short salivary glands, by the terminal cloacal opening, by a pair of seminal vesicles, and by the large respiratory cloacal folds.

**Storing-Kidney in Carinaria mediterranea.‡**—J. Fahringer found that the kidneys of Heteropods did not seem to contain any uric acid. In *Carinaria* his attention was drawn to two gland-like white strands, which shine through at the root of the fin. These organs have been described by Gegenbaur and others; they have been called "concretion-glands," &c., and they certainly contain uric acid. Their structure shows a number of cell-complexes, with more or less round cells containing uric concretions, little plasma, and large nuclei. The posterior portion of the caudal artery passes through the middle. That they have excretory significance seems certain; they are complementary to the true kidney.

**Variation in the Genus Ashmunella.§**—T. D. A. Cockerell supplies statistical data for the plotting of curves of shell diameter of sub-species

\* Zool. Anzeig., xxvii. (1903) pp. 1-7 (7 figs.)

† Zool. Jahrb. xviii. (1903) pp. 359-86 (2 pls.).

‡ Zool. Anzeig. xxvii. (1903) pp. 7-12 (3 figs.).

§ Proc. Acad. Nat. Sc. of Philadelphia, Aug. 1903, pp. 615-6.

of *A. thomsoniana*, from which it appears that the mode for sub-species *cooperæ* falls exactly between *A. thomsoniana* proper and sub-species *porterae*.

**Gastropod Studies.\***—Amadeus Grabau gives an account of the shell development in the genera *Fulgur* and *Lycotypus*, and discusses its bearing on the question of the succession of species in time. A table of genetic relationships of species is given.

**Sexual Differentiation in the Hermaphrodite Gland of *Limax maximus*.†**—P. Ancel comes to an exactly opposite conclusion from M. Babor, regarding the order of appearance of the sexual elements in *L. maximus*. The sex-cells up to a certain time are indifferent and capable of developing as male or female. The determining factor is the proximity of nutritive cells which arise from the same primitive elements as the sex-cells. These tend to produce ova. Their absence is the indirect cause of particular cells developing as male elements. The order of appearance of these three types of cell is such that protogyny is not possible.

#### 5. Lamellibranchiata.

**Utilisation of Carbonate of Lime by Anodonta.‡**—Domet de Vorges communicates the results of an experiment with a young specimen of the freshwater mussel, *Anodonta cygnea*, which, though by no means conclusive, tend to show that this bivalve can utilise the carbonate of calcium in the water. It is noteworthy that in this experiment the magnesium salts remained quite constant.

**Rib Variation in *Cardium*.§**—F. C. Baker has studied this in *Cardium robustum* (= *C. magnum*), *C. isocardia*, and *C. muricatum*, using several hundred specimens of each species from the same general locality. The fact presents itself, that in each species there is a mode or constant which remains unvaried, and from which certain individuals vary sporadically. It also appears that the number of ribs is not a safe character upon which to found a species.

#### Arthropoda.

##### a. Insecta.

**Insects and Floral Colours.||**—John H. Lovell sums up a paper, rich in observational material, in the conclusion, as far as insects are concerned, that their preferences depend, not on æsthetic colour-sense, but on association of particular colours with food material. Conspicuousness, or contrast of the inflorescence with the foliage, may be referred to selection. It is of advantage to the insects, since it enables them to find nectariferous flowers more quickly, and to the plants because it aids in securing cross-fertilisation. Many colours are better than one, since the colours are rendered more conspicuous by contrasts with each other as well as with the foliage, and insects are less liable to visit them indiscriminately. This paper is also referred to under "BOTANY."

\* Amer. Naturalist, xxxvii. No. 440, pp. 515-39.

† Arch. Zool. Expér., series 4, i. (1903), Notes et Revue No. 7, pp. cv-cxv.

‡ Bull. Soc. Zool. France, xxviii. (1903) pp. 149-50.

§ Amer. Naturalist, xxxvii. (1903) pp. 481-8 (7 figs.).

|| Tom. cit., pp. 443-79.

**Position of Repose in Lepidoptera.\***—J. Th. Oudemans has made an elaborate study of the resting pose in Lepidoptera, and has illustrated his memoir with numerous beautiful plates. He discusses the folding of the wings so that only the under surfaces are seen, and the spreading of the wings so that the upper surface is alone prominent. Many detailed peculiarities are described and figured, and the adaptiveness of the results is expounded. He believes strongly in the direct influence of light on the exposed parts, without denying that internal influences are also at work.

**Protective Resemblance in Butterflies.†**—W. S. Rogers calls attention to an un-named butterfly which he found in the granite quarries in the district of Santos, Brazil. The general colouring of the butterfly is a cool-blue grey, exactly the shade of the freshly quarried stone, on which it invariably settled. The weathered surfaces of the granite were greenish-grey. The markings of the butterfly also corresponded to the texture of the rock.

“The facts seem to point to a very rapid evolution of the butterfly’s present colouring, since the quarries in question have probably only existed for some 200 years, and before that time the butterflies could not have found access to a freshly cleft granite-surface.” In an appended note Mr. G. H. Carpenter says that the observation is of much interest, and that there can be little doubt that the colour of the species has changed during the period mentioned under the influence of natural selection.

**Spermatogenesis in Drones.‡**—F. Meves makes a brief note on the remarkable spermatocyte-divisions in the testes of the drone-bee. The division results in a large and a very minute cell, like a polar body; both begin to be transformed into sperms, but the small cells probably degenerate.

**Wax-making Organ of Bee.§**—L. Dreyling has made a careful study of this structure, showing *inter alia* that the “wax-membrane” is a modified glandular area of the hypodermis, and that the secretion comes out by extremely fine canaliculi traversing the chitin. Of much interest is the author’s description of the state of the glandular area at different ages; it functions at the acme of the short life, and thereafter degenerates.

**Hibernation of Ants.||**—Ruggero Cobelli has shown that the duration of the hibernating period of ants is a specific character. This is clearly indicated by a contrast between *Lasius fuliginosus* and *Camponotus pubescens*. Of course the position of the nest and other factors influence the duration of the winter-resting period; but, other things being equal, the duration is a function of the constitution of the species. As regards sensitiveness to cold, and length of hibernating period, similar series may be demonstrated: thus, *Camponotus pubescens*, *Crema-*

\* Verh. k. Akad. Wetenschappen Amsterdam, x. (1903) pp. 1–90 (11 pls.).

† Knowledge, xxvi. (1903) p. 206.

‡ MT. Ver. Schleswig-Holstein, xi. (1903) 2 pp. See Zool. Centralbl., x. (1903) p. 577.

§ Zool. Anzeig., xxvi. (1903) pp. 710–5 (2 figs.).

|| Verh. Zool. Bot. Ges. Wien, liii. (1903) pp. 369–80.

*togaster scutellaris*, *Lasius emarginatus*, and *L. fuliginosus*, form a series in both these respects.

**Connection between Mid-Gut and Hind-Gut in Larval Hymenoptera.\***—C. Rengel has investigated this point in the larvæ of *Vespa germanica*, *Apis mellifica*, and *Lasius niger*. He finds that at the boundary of the two regions the embryonic condition persists throughout the whole of the larval period unchanged (*Apis*, *Lasius*), or almost unchanged (*Vespa*). The mid-gut is, from the start, in organic connection with the hind-gut. The muscularis layer, the membrana propria, and the epithelium, pass from the one region to the other without interruption. The expulsion of the stored contents of the mid-gut is not occasioned by any new formation, but is wholly due to the expansion of the narrow region.

**Interesting Case of Parasitism.†**—K. Grünberg recalls the remarkable parasitism of the ant-decapitating fly, described some years ago by Theodor Pergande.‡ An ant, *Camponotus pennsylvanicus* Geer, which lives in hollow trees and stumps, is attacked by a fly, *Apocephalus pergandei* Coqu., which lays its eggs on its victim's body. The larvæ hatch and penetrate to the head, killing the ant after decapitating it.

**Beetle Embedded in Wall of Human Intestine.§**—D. Sharp records a case observed by W. H. Ligertwood. The lower part of the ileum of an old man of 73 showed two small oval, blackish lumps; the upper one, about eighteen inches above the ileo-cæcal valve, contained a living weevil (*Otiorhynchus tenebrius*) about half-an-inch long. It lay between the mucous membrane and the other coats of the intestine; there were no signs of a cyst-wall, nor of any opening. Dr. Sharp corroborates the identification of the beetle, and calls attention to recent experiments by Thébault, which show that the larva of *Piophilus casei*—the common cheese-maggot—can traverse the whole length of the human alimentary canal without being killed. It appears, therefore, that accounts of the finding of living insects in the human alimentary canal must not be rejected on account of the inherent improbability of life being maintained in such a situation.

**Coloration of Coleoptera.||**—W. L. Tower shows that the most important of insect colours are those of the cuticle. They are not due to drying, oxidation, secretion, or like processes, but are produced by catalytic agents working in the cuticle. The colours develop as the cuticula hardens, and appears first, as a rule, upon sclerites to which muscles are attached. The pigment develops from before backward, and, approximately, by segments, excepting that it may appear upon the head and most posterior segments simultaneously.

A study of the cuticle revealed the existence of enzymes of a new class, called *chitases*. They operate in the hardening and pigmentation of the cuticle. An outer or primary cuticula of chitin is distinguished from an inner layer, composed of a carbohydrate allied to tunicin. The

\* Zeitschr. Wiss. Zool., lxxv. (1903) pp. 221-32 (2 pls.).

† Biol. Centralbl. xxiii. (1903) pp. 679-80.

‡ Proc. Entom. Soc. Washington, iv. No. 4, p. 497, 1901.

§ Proc. Cambridge Phil. Soc., xii. (1903) pp. 199-200.

|| Decennial Publications, Univ. Chicago, x. p. 40 (3 pls.).

colours develop in the primary cuticula, which is derived from pro-chitin, an albumino-gelatinate, through the action of chitases producing chitin and pigments of the azo-, di-azo-, and amido-azo series.

Colour patterns of various genera have many developmental stages in common, and a fundamental plan of colour development was found in all the genera studied.

**Vasiform Orifice of the Aleurodidæ.\***—H. W. Peal describes a small oval organ always present on the posterior surface of the dorsum of both the larval and adult insects. There is (1) a vasiform orifice, a more or less oval pit or depression; (2) a flat, shield-like hinged operculum, which more or less covers the orifice; and (3) a usually two-jointed protrusible lingula, shot out some four or five times a second, and continued as a transparent tube into the cavity of the body. There is no doubt that the function of this remarkable organ is the secretion of honey-dew. The operculum may be regarded as a protective covering. The actual emergence of a globule of honey-dew from the lingula was observed.

**Pine-Beetle.†**—The Board of Agriculture devotes the 91st of their useful leaflets—which may be obtained free of charge—to the pine-beetle,‡ *Hylesinus piniperda* L. This destructive forest insect is described, its life-history is sketched, and the readily available, and usually effective, preventive measures are discussed.

**Economic Entomology.‡**—E. P. Stebbing has published a useful paper on the aims and methods of economic entomology—"The study of the life-histories of injurious insects, with a view to instituting remedial measures against them; this latter question involving an acquaintance with the habits of insects, predaceous and parasitic, upon the noxious pests, and with the capabilities of various insecticides and other remedial measures." "We cannot rely that life-histories and remedies worked out, and applicable in Europe or America, will be of use to us or equally justified in India." "Remedial measures divide themselves into two heads: (1) those applicable through the agency of man; and (2) natural checks brought into play by Nature herself." "The most satisfactory of all remedial measures would be effected by the study of the varieties of plants which best resisted attacks."

**Copeognathæ from Kameroun.§**—Günther Enderlein describes three new Copeognathæ from Kameroun, of considerable zoo-geographical interest, indeed the only forms of Copeognathæ as yet known from West Africa. The new genus *Axinopsocus* is founded, a representative of the little-known family Psoquillidæ, with the species *A. microps*; the two others are *Perientomum hösemanni* sp. n., named after the collector Dr. Hösemann, and *Myopsocus camerounus* sp. n.

**Tasmanian Phasmid.||**—Arthur M. Lea describes a new walking-stick insect, *Acrophylla tasmaniensis* sp. n.; and we refer to his paper

\* Journ. Asiatic Soc. Bengal, lxxii. (1903) pp. 6-7.

† Publications of the Board of Agriculture, leaflet No. 91, p. 6. (3 figs.).

‡ Proc. Asiatic Soc. Bengal, No. iv. (1903) pp. 76-89.

§ Zool. Jahrb., xix. Heft i. pp. 1-8 (1 pl.).

|| Papers and Proc. R. Soc. Tasmania, 1902, published 1903, pp. 81-2 (1 pl.).

because it is the first record of the occurrence of a Phasmid in Tasmania.

**Aquatic Insects of New York State.\***—As the result of studies conducted at the entomological field-station, Ithaca, New York, under the direction of Ephraim Porter Felt, we have a valuable volume of reports which adds much to the knowledge of aquatic insects, and will facilitate subsequent investigations.

J. G. Needham describes the life-history of Zygopterous Odonata—the “damsel flies,” and some new life-histories of Diptera; A. D. MacGillivray deals with aquatic Chrysomelidæ, and gives a table of the families of Coleopterous larvæ; O. A. Johannsen discusses aquatic Nematoceros Diptera; and K. C. Davis contributes a monograph on Sialididæ of both North and South America.

Of much interest is J. G. Needham's account of the food (chiefly Chironomidæ) of the brook trout, and his description of the larva of *Epiphragma fascipennis*, a Dipterous burrower in fallen willow and buttonbush stems lying on the banks of temporary pools. Its residence is sometimes submerged, sometimes exposed, and it has a mode of respiration suited to either condition. MacGillivray's careful study of the respiratory apparatus of the *Donacia* larva solves the old problem as to how the animal, a dweller on the submerged roots of water plants, gets its air—by tapping the store held in the intercellular air-spaces of the plants. The volume has many beautiful plates, some coloured.

**North American Trichodectidæ.†**—Max Morse gives a synopsis of the North American species of *Trichodectes* (biting-lice), which feed on the scales and epidermic excretions of Mammals. Much attention is paid to the so-called “abdominal appendage” of Piaget—a growth of the posterior ventral edge of the antepenultimate segment of the abdomen in the female. Its function is partly in clinging to the hairs of the host, but more especially in the adjustment of the eggs to the hairs. It furnishes excellent specific criteria. Eighteen species are described; their division into ruminant, carnivore, and rodent types strikes one as unnecessarily quaint.

#### β. Myriopoda.

**Marine Myriopods.‡**—Curt Hennings discusses the distribution of *Scolioptanes maritimus* Bergsöe and Meinert (? = *Geophilus marinus* Leach), and *Schendyla submarina* Grube, which are both truly littoral. He has made a particular study of the habits of the first-named species, which is well adapted to live in a fluid medium. It can survive 30 hours' submersion in sea-water, and 70–80 hours' in fresh-water. Many Myriopods have this adaptability in greater or less degree.

**Intercalary Segments.§**—K. W. Verhoeff discusses the intercalary segments of Chilopoda, with reference to the intermediate segments (“*Zwischensegmente*”) of insects. The trunk region of Chilopods was,

\* Bull. New York State Museum, No. 68 (1903) pp. 199–517 (52 pls.).

† Amer. Naturalist, xxxvii. (1903) pp. 608–24 (18 figs.).

‡ Biol. Centralbl., xxiii. (1903) pp. 720–5.

§ Archiv. Naturges, lxi. (1903) pp. 427–41 (1 pl.).

he maintains, originally composed of double-segments, each limb-bearing segment being connected with a preceding segment without limbs more closely than with the succeeding limbless segment. The intermediate segments of insects are degenerate main segments, inherited from Chilopod ancestors, and united with the succeeding main segments into secondary double-segments. But we must refer those interested in this intricate question to Verhoeff himself.

#### δ. Arachnida.

**Development of *Telyphonus caudatus*.**\* — W. Schimkewitsch describes the appearance of the embryo of *T. caudatus* in a series of stages from blastula onwards. On the whole the development exhibits a combination of the features characteristic of spiders, particularly *Pholcus*, and scorpions. There are no important points peculiar to *Telyphonus*.

#### ε. Crustacea.

**Death-Feigning in Terrestrial Amphipods.**† — F. J. Holmes has studied this phenomenon in *Telorchestia longicornis*, *Orchestia agilis*, &c., in which contact with rigid bodies evokes "a sort of hypnotic effect apparently." The author regards this as the expression of an "instinct" evolved in the course of natural selection; but no facts are adduced which contradict the view that the phenomenon is a "Reflex-tonus," such as Verworn has described in cases where the possibility of an instinct is out of the question.

**Emergence of Lobster Larvæ.**‡ — Fabre-Domergue and E. Biéatrix have carefully studied the process of hatching in the common lobster (*Homarus*). It occurs between 8 p.m. and 9 p.m., and the mother plays a part, moving about as if on tiptoe, and suddenly working the swimmerets so as to jerk out the larvæ as soon as they complete the first moult after hatching.

**Habits of *Cambarus*.**§ — J. Arthur Harris discusses some of the chief facts known in regard to the habits and distribution of North American crayfishes. Different species occur in different parts of the same stream. The burrowing and the "chimney-building" of various species is discussed at some length. The primary use of the burrow seems to be to collect the water in a sort of cistern, so that the crayfish can keep its gills moist when water in the pools is scarce. Winter-habits, breeding-habits, coloration and the like, are briefly alluded to.

**North American Amphipods.**|| — S. J. Holmes contributes a useful synopsis of the Amphipods of the Atlantic coast of North America. The Amphipod fauna of the Pacific coast is still very imperfectly known. The species from the Arctic regions of the American continent are also omitted, except when they range into the region covered. The majority of the known species of eastern North America are, however, repre-

\* Zool. Anzeig., xxvi. No. 707, pp. 665-85.

† Biol. Bull., iv. (1903) pp. 192-6. See Zool. Centralbl., x. (1903) pp. 605-6.

‡ Comptes Rendus, cxxxvi. (1903) pp. 1408-9.

§ Amer. Naturalist, xxxvii. (1903) pp. 601-8.

|| Tom. cit., pp. 267-92.

sentatives of the general circumpolar fauna, and are found also on the northern coast of Europe and Asia. The Amphipod fauna of Labrador is very similar to that of Norway, the differences naturally becoming greater as we pass southward along the shores of the two continents. Nevertheless there are not a few species common to the Mediterranean and the southern coast of New England. The tendency of some investigators to describe a species as new when met with for the first time in North America, has, therefore, resulted in the production of many synonyms. Like others of the series, the diagnostic key submitted is of great value.

#### Annulata.

**Sperm Centrosome and Aster of *Allolobophora fœtida*.**\*—Katharine Foot and E. C. Strobell point out that during the past few years evidence has accumulated which assigns to the egg attraction-sphere a position where it threatens to usurp all the functions hitherto claimed for the male attraction-sphere. This promotion of the egg-centrosome and aster, with its satellites the cytasters, seems to have been at the expense of the male centrosome, until even Boveri suggests the hypothesis that instead of the spermatozoon bringing a centrosome into the ovum, it may be that it simply induces the formation of a centrosome, from whose division all that follow are derived.

The egg of *Allolobophora* furnishes evidence that the centrosome of its male attraction-sphere is part of the spermatozoon itself, but *Allolobophora* fails to offer any evidence that this centrosome gives rise to one or both of the cleavage centrosomes. On the contrary, the evidence points to the *de novo* origin of the cleavage centrosomes.

**Rôle of Amœbocytes in *Polymnia nebulosa*.**†—M. Siedlecki has an interesting study of the varied rôle of the cœlomic amœbocytes in this Annelid. He describes their phases, e.g. the tendency to agglutinate in plasmodia—a tendency which he attributes largely to the viscosity of the surfaces of the amœbocytes. The engulfing of foreign bodies was watched, and is described. Reasons are given for believing that they are important in dealing with the sporozoon parasites, such as the free cysts of *Caryotropha*. Of particular interest is the description of the way in which the amœbocytes utilise the cytophores formed in the spermatogenesis. The expense of reproduction is thus lessened.

**Observations on the Japanese Palolo (*Ceratocephale osawai* sp. n.).**‡ Akira Izuka gives the characters of this new species, and discusses at some length its swarming habits, which he studied on the Sumida river, Tokyo. The sexually mature worms swim out four times a year in the months of October and November. The swarming period extends from one to four consecutive days, immediately following the days of the new and the full moon. There is a parallelism between the occurrence of the densest swarm and the highest spring tide during the months concerned. The genital products are discharged while the worms are actively swimming.

\* Amer. Journ. Anat., ii. (1903) pp. 365-9 (1 pl.).

† Ann. Inst. Pasteur, xvii. (1903) pp. 449-62 (2 pls.).

‡ Jour. Coll. of Science, Imp. Univ. of Tokyo, xvii. art. 11, pp. 1-37 (2 pl.).



**Studies on Gephyrea.\***—H. Augener describes first of all a collection of Sipunculids made by Dr. Brock in Java and Amboina, including 19 species of *Phascolosoma*, *Dendrostoma*, *Phymosoma*, *Sipunculus*, *Aspidosiphon*, and *Claosiphon*. Then follows an account of the other Sipunculids and Echiurids in the Göttingen Museum. A description is given of the diverticula of the hind-gut in various Sipunculids and of Keferstein's vesicles in *Sipunculus cumanensis* Kef. Augener then turns to the foreign bodies and parasites found in Gephyrea, notably a new Nematode—*Gephyronema leve*, g. et sp. n.—and an endoparasitic Crustacean (Copepod?) *Siphonobius gephyreicola* g. et sp. n.

**Distribution of Mid-water Chætognatha in North Atlantic.†**—R. T. Günther finds that the dark intermediate waters of the ocean into which the solar rays do not penetrate, are inhabited by a population of Chætognatha which, during the month of November at all events, is much denser than the population of the upper strata, into which sunlight penetrates. A chart, which shows depth in fathoms, areas dredged, size and numbers caught, illustrates the paper.

#### Nematohelminthes.

**Structure of Paragordius varius Leidy.‡**—Thos. H. Montgomery, jun., has made a big contribution to our knowledge of the Gordiacea by this important memoir. Vejdowsky's conclusions as to Gordiacean structure (which have not been generally accepted by later workers) are in most particulars corroborated. In regard to certain points, additions have been made to Vejdowsky's observations, notably in regard to the structure of the nervous system; and in the interpretation of the affinities of the group, Montgomery has reached somewhat different results.

While the bulk of the memoir is a thorough account of the structure of *Paragordius*, we can only refer to the general conclusions as to the position of the Gordiacea. With the Nematoda the Gordiacea have in common only one important structure, the tubular genitalia and their opening into the cloaca. With the Annelids they agree in the structure and innervation of the musculature, and in having dorso-ventral mesenteries which cross the body cavity. They differ from Annelids in absence of true metamerism, cerebral ganglia, vascular system, setal sacks, &c. They cannot be regarded as highly degenerate Annelids, as Vejdowsky suggested, nor yet as modified Nematodes, as most authorities suggest. They must be considered as a group of isolated position, as Grenacher, von Siebold and Villot have regarded them. The group contains three well-defined genera, *Gordius*, *Paragordius*, and *Chordodes*.

#### Platyhelminthes.

**Bionomics of Convoluta Roscoffensis.§**—Dr. F. W. Gamble and F. Keeble have made a number of extremely interesting observations on the bionomics of *Convoluta roscoffensis* with special reference to its green

\* Arch. Naturges., lxi. (1903) pp. 297-371.

† Annals. and Mag. Nat. Hist., series 7, xii. No. 69, pp. 334-337 (1 pl.)

‡ Zool. Jahrb., xviii. (1903) pp. 387-474 (7 pls.).

§ Proc. Roy. Soc., lxxii. No. 478, pp. 93-98.

cells. Amongst the conclusions arrived at are, that *Convoluta* has not lost its power of independent nutrition. It feeds voraciously, and obtains little if any nourishment from the reserves of its green cells; these are not symbiotic, they derive food from the animal and appear to be facultative parasites; the green cells are the result of infection by colourless cells, which are taken up in company with other organisms and are carried by wandering cells to the periphery, where the majority become green. It is suggested that the colourless cell is a saprophytic stage in the life-history of the green cell.

*Convoluta* lives in a film of water, and is neither a sub-aerial nor a marine animal. The stations occupied are remarkably constant, and show diurnal and fortnightly variations in the size of the colonies, the former being tidal, and the latter due to periodicity of reproductive phenomena. Interesting tropisms are also described.

**Two Remarkable Sporocysts from *Mytilus latus*.**\*—W. A. Haswell describes (a) the sporocysts of an *Echinostomum* very abundant in about 10 p.c. of the mussels examined. They multiply not only by budding, or rather binary fission, but also, though comparatively rarely, by a process corresponding to that by which in many, if not most sporocysts rediae are formed. One of the remarkable features is the occurrence of pigment in the germinal epithelium; another, though it may have been overlooked in other cases, is the giving off of colourless nutritive globules by the germinal epithelium. The structure and development of the cercariae is described. (b) Haswell also found the sporocysts and cercariae of a species of *Gasterostomum*—the cercariae having the remarkable form known as *Bucephalus* v. Baer.

**Nemerteans of Norway.**†—R. C. Punnett raises the list from 15 to 34 species. Between 40 and 50 Nemerteans are known from British coasts, and of these only 17 have hitherto been found in the Norwegian fjords. Indeed the fjord fauna is very distinct from that of the British area, almost as distinct perhaps as the latter is from the Mediterranean fauna.

The distribution of one of the new species, *Cerebratulus longifissus*, is very peculiar. So far as is known it occurs only in Norway and in the South Atlantic off Marion Island. At present it remains a puzzle.

In *Lineus cinereus*, it was found that the œsophageal nerves meet below the œsophagus, which is consequently surrounded by a complete nerve ring. This condition has been found by Punnett in other Heteronemerteans, but in none of the more primitive members of the phylum.

#### Uncertæ Sedis.

**Embryonic Fission in the Genus *Crisia*.**‡—Alice Robertson has studied the budding of the embryo in the genus *Crisia*. In male colonies of *C. eburnea* a few of the primitive germ-cells which are developed earlier than the polypide buds attach themselves to each of

\* Proc. Linn. Soc. N.S.W., xxvii. (1902, published 1903) pp. 497-515 (2 pls.).

† Bergens Museums Aabog, 1903, No. 2, 35 pp. (2 pls.).

‡ Univ. of California Publications, Zoology, i. No. 3, pp. 115-56. pls. 12-15.

these latter as it arises. They form the beginning of a testis, which in the majority of cases degenerates before the spermatozoa become mature. Certain ova similarly unite with buds, and may develop into an embryo while the bud as such becomes aborted; or the bud may develop and the ovum degenerate. It is not certain whether fertilisation occurs, and the possibility of parthenogenesis is suggested. After the primitive embryo has reached a certain size it divides to form secondary embryos. In *C. occidentalis* the secondary embryos divide to form tertiary ones, which develop into ciliated larvæ. At the close of its proliferation the primary embryo itself becomes a larva.

**Studies in Pacific Coast Entoprocta.\***—Alice Robertson describes two new forms of Entoprocta—*Myosoma* g. n., whose distinguishing generic character is the possession of a muscular calyx, and *Gonypodaria ramosa*, sp. n., a branching form with four or more muscular expansions on the stalk. She notes also the occurrence on the Pacific Coast of species previously described.

**Ascorhiza and Related Alcyonidia.†**—Alice Robertson, in a study of fresh material of *Ascorhiza occidentalis*, gives a detailed description of this form. She describes also a stalked example of *Alcyonidium*—*A. pedunculatum*, sp. n., from the Pribilof Islands—whose characters require the expansion of the Family definition as given by Hincks, by the phrase “or zoarium, in whole or in part elevated upon a stalk, or a short peduncle.”

#### Rotatoria.

**Morphology of the Rotatorian Family Flosculariadae.‡**—Thos. H. Montgomery gives a fairly complete description, with figures, of the anatomy of *Floscularia campanulata*, *Apsilus vorax* and *Stephanoceros*, without adding anything of importance that is not already known. One statement however is new, if it proves to be correct, namely that in *Stephanoceros* and *Floscules* the mastax is fully developed, and consists of well formed unci and manubria, fulcrum and rami. A protest should be raised against the author's changing the well-known name of *Stephanoceros eichhornii* into that of *St. fimbriatus*, on the ground that Goldfuss in 1820, in a general Manual of Zoology, called this animal *Coronella fimbriata*. Prof. Ehrenberg, who himself indicates this fact in his Synonymy of the species, has been the founder of this branch of Zoology, and it is quite unnecessary to go beyond him in naming species of Rotifers. If the author's practice were to be followed, many names would have to be changed, with the result of causing endless confusion.

#### Echinoderma.

**Phagocytic Absorption of Sex-Cells in Echinocardium cordatum.§**—Maurice Caullery and Michel Siedlecki have followed a hint given by Giard in a paper in 1877.|| They find that in the two sexes

\* Proc. Calif. Acad. of Sciences, series 3, Zoology, ii. No. 4, pp. 323-48 (1 pl.)

† Op. cit. *supra*, iii. No. 3, pp. 99-108 (1 pl.).

‡ Proc. Acad. Nat. Sci. of Philadelphia, 1903, pp. 363-95 (4 pls.).

§ Comptes Rendus, cxxxvii. (1903) pp. 496-8.

|| Op. cit., lxxxv., 5th Nov. 1877.

there is a precisely parallel total absorption of the differentiated sex-elements which remain unused after the breeding season. In many animals a similar phagocytic absorption has been observed, but it has a remarkable intensity in *Echinocardium cordatum*, which is also a very convenient subject for studying the process.

**Development of the Biserial Arm in Certain Crinoids.\***—A. W. Grabau finds that new arm-plates introduced at the tip of the growing arm are uniserial. The apical plates, at least in the less specialised biserial species, are rectangular, and change with further growth to wedge-shaped and later to biseriality. This is not primarily an old age character, since this condition is found in the apical arm-plates of young crinoids.

**List of Irish Echinoderms.†**—A. R. Nichols gives a list of Irish Echinoderms with their localities, together with their general distribution. He notes as peculiar to Irish shallow waters two doubtful species of *Cucumaria*, *C. andrewsi* and *C. saxicola*, and five deep-water forms, *Holothuria aspersa*, *Astropecten sphenoplax*, *Pentagonaster greeni*, *Hymenaster giganteus* and *Cidaris gracilis*.

**Echinoderms of East Finmark.‡**—Canon A. M. Norman gives a list of these, briefly indicating their localities and authorities. No new species are recorded.

#### Cœlentera.

**Commensalism between Sea-Anemone and Crab.§**—Otto Bürger notes that the common Pacific sea-anemone—*Antholoba reticulata*—has a distribution area which overlaps that of the crab, *Hepatus chilensis*, in the Bay of Coquimbo. In this area the sea-anemone is usually found seated on the cephalothorax of the crab; in other regions it does not seem to have discovered any suitable bearer. Out of sixty crabs captured in Coquimbo, only four were without the anemone, and some had two or more. Bürger was twice successful in observing a sea-anemone clambering on to the crab by slow stages, after it had been separated from it for four days. The association is not fortuitous, and the anemone takes the initiative in establishing it. Probably the benefit is on its side only.

**Revision of the Nephthyidæ.||**—W. Kükenthal has published a welcome revision of one of the most difficult Alcyonarian families, the Nephthyidæ, which includes eight genera—*Lithophytum*, *Eunephthya*, *Capnella*, *Lemnalina*, *Scleronephthya*, *Nephthya*, *Spongodes*, and a new genus *Neospongodes*. A number of new species, especially of *Nephthya*, are described.

**Occurrence of Monograptus in New South Wales.¶**—T. S. Hall corroborates J. Mitchell's record of the occurrence of Graptolites in the

\* Amer. Journ. Sci., xvi. (1903) pp. 289-300 (11 figs.).

† Proc. Royal Irish Acad., xxiv. sec. B, part 3, pp. 231-67.

‡ Op. cit., xii. series 7, No. 70, pp. 406-17.

§ Biol. Centralbl., xxiii. (1903) pp. 678-9.

|| Zool. Jahrb., xix. Heft. i. (1903) pp. 99-172 (3 pls.).

¶ Proc. Linn. Soc. N.S.W., xxvii. (1902, published 1903) pp. 654-5 (1 fig.).

Silurian of Bowring and Yass. The specimens are undoubtedly examples of a *Monograptus*, apparently belonging to the group typified by *M. dubius*, which ranges through almost the whole of the Lower Ludlow and Wenlock in Britain.

**Development of Graptolites.\***—E. Kerforne has found among the Graptolites of the Armorican "massif" of Brittany a number of developmental stages of *Monograptus convolutus* His, showing the "float" attached to the rhabdosome, numerous siculae with the first hydrotheca, and so on.

**The Genus Romingeria.†**—Charles E. Beecher gives an account of the structure and habits of four characteristic species of the genus *Romingeria*, in which some details not hitherto observed are noted. He reviews the history and synonymy of the type species, *R. umbellifera*, and briefly refers to possible affinities with other genera of palaeozoic tabulate corals, e.g. *Pleurodictyum* and *Favosites*.

### Porifera.

**Asterosteptidæ.‡**—E. Topsent discusses this new family of Choristid sponges, which ranks along with Gray's Geodidæ and Sollas's Stellettidæ in the tribe Astrophora. The proposed new family includes the Theneinæ and Pachastrellidæ as sub-families.

**Insufficiently Described Monaxonia.§**—Joh. Thiele has revised twenty-seven species of Monaxonial sponges which Schmidt did not adequately describe. He has made use of the original types, or of sections which Prof. Weltner had previously made of many. And after filling up some of the many gaps in the descriptions, he shows what changes in nomenclature are necessary.

**Calcareous Sponges from the Pacific.||**—Josef Preswisch describes two new species of *Leucetta*, two of *Sycandra*, and one of *Ebnerella*, collected by Schauinsland from Chatham Islands, Laysan, &c. The collection also included the two cosmopolitan species, *Ascetta primordialis* and *Sycandra coronata*.

**Pacific Horny Sponges.¶**—R. Baar describes a collection of thirty-six specimens collected by Schauinsland from the Pacific. The collection included five genera and thirteen species, and *Stelospongia flava* is established as a new species.

### Protozoa.

**Sexual Reproduction of Pterocephalus.\*\***—L. Léger and O. Duboscq have studied the highly specialised anisogamous conjugation of very minute rod-like spermatozoa with large ovoid ova, well-equipped with

\* Trav. Sci. Univ. Rennes, i. (1902) pp. 187-90 (9 figs.).

† Amer. Journ. of Sci., xvi. No. 91 (July 1903) pp. 1-11, pls. 1-5.

‡ Trav. Sci. Univ. Rennes, i. (1902) pp. 317-31.

§ Archiv. Naturges., lxi. (1903) pp. 375-98 (1 pl.).

|| Zool. Jahrb. xix. Heft. i. (1903) pp. 9-26 (3 pls.).

¶ Tom. cit., pp. 27-36 (3 figs.).

\*\* Arch. Zool. Expér., I. series 4 (1903). Notes et Revue, No. 9, pp. cxli.-vii. (11 figs.).

reserve-material, in *Pterocephalus nobilis*, parasitic in *Scolopendra cin- gulata* Latr. The process of amphimixis is closely similar to that in Metazoa, the division of the zygote is comparable to segmentation in some Metazoa, and the distinction between the male and female parents is well-marked.

**New Parasite of Hermit-Crabs.\***—L. Léger and O. Duboscq describe *Aggregata vagans* sp. n., a polycystidean, gymnosporous Gregarine, parasitic in or on the alimentary tract, or in the parivisceral cavity of *Eupagurus prideauxi*. It is closely allied to *Aggregata celomica* Léger from *Pinnotheres pisum*.

**Phototaxis in Volvox.†**—S. J. Holmes maintains that the larger size of the red pigment-spots at the anterior pole of the *Volvox* colony is of importance in relation to phototactic movements. But it does not appear that he has sufficiently separated in his experiments the direction of the illumination from the intensity thereof.

**Progress in Study of Coccidia.‡**—M. Lühe has done a useful and laborious piece of work in summing up with bibliographical details what has been done in regard to Coccidia in the last four years. After discussing the classification and the new forms, he devotes the bulk of his account to the studies on the life-history of *Eimeria*, *Isospora*, *Cyclospora caryolytica* Schand., *Adelea*, *Klossia*, *Legerella*, *Eucoccidium*, *Caryotropha mesnili* Siedl., *Klossiella muris* Smith and Johnson. The last section of the paper deals with the pathology of Coccidial infection.

\* Arch. Zool. Expér. I. series 4 (1903). Notes et Revue, No. 9, pp. cxlvii.-li. (6 figs.).

† Biol. Bull., iv. (1903) pp. 319-26. See Zool. Centralbl. x. (1903) 592-3.

‡ Zool. Centralbl. x. (1903) pp. 617-61.



## BOTANY.

## GENERAL,

## Including the Anatomy and Physiology of Seed Plants.

## Cytology,

## including Cell Contents.

**Studies in Spindle Formation.\***—A. A. Lawson gives the result of his studies in this subject. Previous observations showed that there is considerable variety in the method of spindle-formation, and it would seem that there are several distinct types; but the differences between them are too great, and the number of forms worked out in detail are too few, to allow of any generalisations. For his present paper the author has studied the pollen mother-cells of *Iris florentina*, of *Disporum Hookeri*, of *Hesperaloe Davayi*, and of *Hedera Helix*. In *Iris*, formation of the spindle is initiated by the transformation of the cytoplasmic reticulum close to the nuclear membrane into a web of kinoplasmic fibrils, which forms a complete zone about the nucleus. After increasing to a certain thickness, the zone projects outwards at irregular intervals, forming a series of sharply pointed cones, which apparently develop at the expense of the cytoplasmic reticulum into which they project, and as they grow the fibrils composing them lengthen and converge at the apex. The nuclear wall persists until the completion of the cones, which fuse on the breaking down of the membrane until there are two groups of them pointing in opposite directions. The points at which the cones forming these groups meet at their apices become the poles of the bipolar spindle.

In *Disporum* the first indication of the spindle is the formation of a web of kinoplasmic fibrils partially surrounding the nucleus, and formed from the cytoplasmic membrane, but, unlike *Iris*, the meshes of the web do not run parallel to the nuclear membrane. The web increases irregularly, forming several projections which become the primary cones of the spindle. As they grow outward the cones become sharp-pointed, and their fibrils are sharply defined. The nuclear wall then breaks down, and the cones unite in two groups to form the bipolar spindle.

As in *Iris* and *Disporum*, the spindle in *Hesperaloe* originates from a web of kinoplasm, which completely surrounds the nucleus and is of cytoplasmic origin; the fibrils of the web run parallel to the nuclear membrane. The web develops a series of sharp-pointed projections which become the primary cones of the spindle. As the nuclear wall disappears the cones collect in two groups, and fusion at their apices effects the bipolar condition. In *Hedera* the cytoplasm close to the nucleus becomes changed into a web of kinoplasmic fibrils, surrounding the nuclear membrane; the zone forms a number of sharp projections which become the primary cones of the spindle. As these cones grow

\* Bot. Gazette, xxxvi. (1903) pp. 81-100 (2 double pls.)

outward the fibrils composing them become more sharply defined, elongate, and converge at their apices. The events that follow are essentially the same as those in *Iris*, *Disporum* and *Hesperaloe*.

The author suggests the following classification :—

Type 1, represented by *Gladiolus*, *Iris*, *Disporum*, *Hesperaloe*, *Hedera*, *Osmunda*.

Type 2, by *Cobæa*, *Passiflora*, *Lavatera*.

Type 3, by *Equisetum*.

Type 4, by *Agave*.

**Reduction of Chromosomes.\***—J. B. Farmer and J. E. S. Moore have re-investigated the disputed question of the method of chromosome reduction in a number of plants and animals. They agree with neither of the two usual interpretations, but believe that after splitting longitudinally the spireme thread as a whole becomes bent into distinct loops and U-shaped figures. The original split in the arms of the loops usually disappears, and the two arms become approximated and form the chromosomes, which may afterwards take on the form of rings or rods. The number of chromatic loops corresponds with the reduced number of chromosomes, so that it seems evident that the chromosomes are really bivalent. The chromosome breaks apart during the heterotype division at the bend of the loop, bringing about a reduction which is qualitative as well as quantitative. The actual separation of the longitudinal halves observed in the early spireme is deferred until the second division.

**Crystal-cells and the Leaf of Citrus.†**—H. v. Guttenberg has studied the idioblasts containing calcium oxalate in leaves of *Citrus medica* and *C. vulgaris*. He finds them to be of subepidermal origin, arising in the uppermost layer of the palisade tissue and the lowest layer of the spongy parenchyma. The crystals are surrounded in an early stage by a cellulose membrane, which later becomes blended with the thickening cell-membrane. The crystal-cells penetrate by sliding growth into the epidermis, thereby splitting the wall of the overlying epidermal cells. In many cases they reach the outer wall and displace the layer of cellulose, replacing it by their own. Finally they exert an influence on the formation of the cuticular layer, in that, instead of a series of larger peg-like outgrowths, an irregular quantity of smaller ones is formed.

**Alkaloids of *Dicentra formosa*.‡**—G. Heyl, by digesting roots of this plant with alcohol containing some acetic acid, obtained among other bodies two alkaloids in small quantities which have some resemblance to homochelidonine and chelidonine respectively, but appear to be different from these. Along with the first a small quantity of a greenish-yellow substance crystallises, which gives a blue fluorescence in alcoholic solution and is perhaps identical with the colouring matter isolated by Schlotterbeck and Watkins from *Stylophorum diphyllum*.

\* Proc. Roy. Soc., lxxii. (1903) p. 104 (6 figs.).

† S.B. k. Akad. Wiss. Wien, exi. (1902) pp. 855-72 (1 pl.).

‡ Arch. Pharm., cxxli. (1903) pp. 313-20. See also Journ. Chem. Soc., lxxxiv. i. (1903) p. 716.



## Structure and Development.

## Vegetative.

**Meriphyte of the Cycads.\***—H. Matte has studied the vascular system of the leaf (the meriphyte of Lignier) in the Cycads. He finds that, except in *Cycas*, the foliolar traces in the rhachis consist of several bundles. The typical horse-shoe form is seen only in *Cycas*, *Dioon*, and *Ceratozamia*, the majority of the species of *Zamia*, and some species of *Macrozamia*. In *Encephalartos*, and species of *Zamia* and *Macrozamia* the foliar arc shows in the base of the petiole a complication which may be considerable, and which is due to tensions and bundle-displacements which are caused by foldings of the foliar arc. The arc in *Stangeria* and *Bowenia* differs from that in the other genera previously mentioned; that of *Bowenia* has the same form as that of *Angiopteris*. The form of the foliar arc in young leaves is generally simpler than in mature ones, on the study of which the results given were based.

**Sap-excreting Elements in *Tropæolum majus*.†**—G. Irgang shows that the drop of clear sap which appears on the wound when the stem, leaf-stalk or blade of *Tropæolum majus* is cut, comes from the young vascular bundle-elements which remain for a remarkably long time unligified, thin-walled and very rich in sap. Towards the top of the stem almost all the vascular elements are unligified; as we descend the stem the proportion diminishes, hence in the older parts of the stem the exudation of sap is less in quantity. In the epidermis of the upper and under leaf-surface occur mucilage-cells characterised by their size, contour, and cell-contents.

**Regeneration of the Assimilating Mechanism in *Streptocarpus* and *Monophyllæa*.‡**—F. Pischinger gives the following results of his experimental study. In *Streptocarpus* and *Monophyllæa* the cotyledons are of unequal size when in the seed. In *S. Wendlandi* there is at the base of the larger cotyledon a small-celled meristem, which during germination enlarges, and later forms the secondary leaf-like growth of the single leaf of the plant. The axis of the inflorescence subsequently develops from a definite portion of the same meristem; since this meristem is derived directly from the meristematic tissue of the embryo, the inflorescence cannot be regarded as an adventitious structure. Similarly, the apparent leaf-stalk of the larger cotyledon must be regarded as an axial organ united with the stalk, and this holds also for the species which form leaf-rosettes.

In the one-leaved *S. Wendlandi* not only does regeneration of the larger cotyledon occur if its basal meristem remains either entirely or in part, but the whole cotyledon will re-form if cut away; and frequently the smaller cotyledon becomes stimulated to stronger growth by destruction of the larger and forms a secondary leaf-like growth, or the plant may be induced to form new true foliage-leaves. On the other hand in *S. Gardeni*, which forms leaf-rosettes, no regeneration of the

\* Comptes Rendus, cxxxvii. (1903) pp. 80-2.

† S.B. k. Akad. Wiss. Wien, cxi. (1902) pp. 723-1 (1 pl.).

‡ Tom. cit., pp. 278-300 (2 pls.).

destroyed larger cotyledon occurs, but the smaller seed-leaf is stimulated to a stronger development and the formation of secondary growth; new foliage-leaves are also formed.

In *Monophyllaea* a regeneration of the larger cotyledons occurs only when its basal meristem is intact. If this is also removed the plant perishes, the smaller seed-leaf being unable to take on the function of the larger.

RUDOLPH, KARL—*Beitrag zur Kenntnis der Stachelbildung bei Cactaceen.* (On formation of spines in Cactaceæ.)

[The spines in *Opuntia missouriensis* are epidermal outgrowths, and not homologous with leaves or branches.]

*Oesterr. Bot. Zeitschr.*, liii. (1903) pp. 105-9 (1 pl.).

CHIFFLOT, J.—*Sur la symétrie bilatérale des radicelles de Pontederia crassipes* Mart. (On the bilateral symmetry of the rootlets of *Pontederia crassipes* Mart.)

*Comptes Rendus*, cxxvi. (1903) pp. 1701-3

#### Reproductive.

**Gametophytes and Embryo of Taxodium.\***—W. C. Coker finds that the staminate cones begin to develop in September or October, and by winter the pollen-mother-cells are formed. Development is resumed in spring. The reducing divisions in the pollen-mother-cells resemble those in *Larix*, and the reduced number of chromosomes is probably twelve. There is a resting stage after the first division in the mother-cells. About ten days after the reducing division a generative cell becomes separated from the tube-cell; no sterile prothallial cells are formed. The generative cell divides into central cell and stalk-cell from two to three weeks after pollination, when the tube has grown some distance. The tube reaches the prothallium earlier than in any case previously described, sometimes even before the formation of a cellular tissue in the latter. The arrangement of the nuclei in the pollen-tube is the same as in other Conifers. The central cell, which has a distinct membrane, divides, simultaneously with the division in the central cell of the archegonium, to form the two sperm-cells.

The ovulate cones also begin their development in autumn and continue growth through the winter. At the time of pollination the single megaspore mother-cell may be distinguished; it is filled with starch, as are also the surrounding tapetal cells. Two reducing divisions occur, but only three cells are formed—the upper of the two first produced not dividing again. The lower of the two potential megaspores, resulting from the second division in the lower cell, develops into the female gametophyte, the two upper cells disorganising. The archegonia are arranged as in the Cupressæ; the number of the neck-cells varies from two to sixteen or more. The central cell is very long and contains two conspicuous kinoplasmic areas, one at the upper end near the nucleus and the other in the lower end beneath the large central vacuole. When the ventral canal nucleus is cut off the upper of these masses takes part in the division, while the fragmented lower one fills the base of the archegonium with peculiar figures. A ventral canal nucleus is cut off just before fertilisation, but is not separated from the cytoplasm of the egg, and after fertilisation moves back towards the centre and divides amitotically; this probably assists in nourishing the embryo.

\* *Bot. Gazette*, xxxvi. (1903) pp. 114-33 (11 pls.).

The spindle of the ventral canal cell-division is almost entirely of nuclear origin, and the chromosomes are derived largely from the nucleolus. The egg nucleus contains a large amount of granular material, but a chromatin reticulum is always present. This granular material is largely used in the formation of the spindle of the fusion nucleus.

Fertilisation occurs about the middle of June, and two or more sperm-cells may enter an archegonium, but only one fuses with the egg. The sperm-cell passes through the cytoplasm of the tip of the egg, and reaches and enfolds the female nucleus. The larger part of the cytoplasm of the egg takes no direct part in the formation of the embryo, but is digested and used by the latter in its growth. The first division occurs after the fusion nucleus has reached the base of the archegonium. Eight free nuclei are formed and arrange themselves in two tiers, the upper of which generally contains six, the lower two; cell walls are formed, but the upper side of the upper tier is left open. This open tier divides, by walls at right angles to the long axis of the archegonium into the rosette of free nuclei above and the suspensors below. The two cells of the lower tier divide at the same time by walls parallel to the long axis of the archegonium, forming four cells in one plane. The suspensors may or may not separate on elongation, forming several or only one embryo from one archegonium.

The author considers that *Taxodium* should be removed from the Taxodiæ to the Cupresseæ, leaving *Sequoia*, and perhaps other genera of the same tribe, to be included in a tribe of their own under another name.

**Morphology of Angiosperms.\***—The present volume forms the second part of the work on Seed Plants, the first part of which, by the same authors, appeared in 1901. Part I. dealt with the Gymnosperms; in Part II. the Angiosperms are treated on somewhat similar lines. In the interval between the times of publication of the two parts, views on the relationship between the two great groups of seed-plants have become somewhat modified. The tendency of the results of recent work is to emphasise the distinctness of the two groups, and, especially by virtue of the light thrown on the Cycadofilices, to bring out more strongly the affinity of Gymnosperms with the Pteridophyta. The origin of the Angiosperms still remains obscure, and the light thrown on the phylogeny of the other group seems but to emphasise the isolation of the larger division of seed-plants. Messrs. Coulter and Chamberlain express their conviction that such an association of the two groups as was contemplated would help to emphasise a relation which does not exist, and that Gymnosperms and Angiosperms should be treated as independent groups co-ordinate with Pteridophyta. The two parts of their work are therefore to be regarded as independent volumes.

Another point of interest which is raised is the relation between the subdivisions of the Angiosperms—the monocotyledons and dicotyledons respectively. In their Introduction, and again in chapter xv. (Phylogeny of Angiosperms) the authors discuss the relationship between

\* 'Morphology of Angiosperms.' By J. M. Coulter and C. J. Chamberlain. 8vo, x. and 348 pp., 113 figs. Appleton, New York, 1903.

the two divisions, and have been at some pains to bring together the various views on this subject. At present, however, it does not seem possible to come to any definite conclusion. But whether the group be mono- or di-phyletic, and if monophyletic whether dicotyledons or monocotyledons be the older, there can be no question that the two divisions are naturally and intimately associated. "The characters that separate them . . . are cumulative rather than specific," and in a morphological account, such as the present, their separation would involve useless repetition. Hence the subject-matter is not arranged, as in the case of the Gymnosperm volume, according to families, but the subdivision is a morphological one.

The chapters treat in succession of the flower, the micro- and megasporangium, the female and male gametophyte, fertilisation, the endosperm, and the embryo. Then follow chapters on the classification of the monocotyledons and of the two great groups of dicotyledons (Archichlamydeæ and Sympetaleæ), the geographic distribution of Angiosperms, fossil Angiosperms, and the phylogeny of Angiosperms. Finally, Prof. E. C. Jeffrey contributes two chapters on the comparative anatomy of the Gymnosperms and their allies and on the comparative anatomy of Angiosperms.

The book supplies an excellent and much-needed presentation of the subjects treated, and the full references to literature which are given at the end of each chapter show the student where to go for further information.

The figures, many of which are original, are both plentiful and good.

**Development of the Ovule in Casuarina.\***—H. O. Juel has amplified and amended in a few details Treub's account of the ovule in this genus. The most important point of his work is the observation of a tetrad division of the embryo-sac mother-cells, the first nuclear division being of a heterotype nature and showing a reduction of chromosomes.

**Formation of the Egg and Division of an Antipodal Cell in the Juncaceæ.†**—M. Laurent finds that the embryo-sac of the Juncaceæ shows the normal arrangement of eight nuclei. The two synergids disappear before fertilisation; the two polar nuclei were not observed to fuse. At the approach of fertilisation the median antipodal cell becomes very conspicuous, advances towards the exterior of the sac, and occupies a corresponding position to the egg-cell at the micropylar end; it stains more strongly than the two lateral antipodal cells which remain small. The author was unable to induce the germination of the pollen tetrads in a damp chamber, either in pure water or in different sugar solutions, but they germinated readily in water in the presence of the stigma. Pollination is direct in several species of *Juncus*, especially in *J. Bufonius* where the flowers are always cleistogamic. In *Luzula* protandry is universal.

After fertilisation the two lateral antipodals soon disappear, but the median grows considerably: its nucleus divides into several unequal daughter nuclei; these again divide and form a nucleated area of highly

\* *Flora*, xcii. (1903) pp. 284-93 (1 pl.).

† *Comptes Rendus*, cxxxvii. (1903) pp. 499-500.

chromatic protoplasm which is in contact with the earlier formed nuclei of the endosperm, and gradually disappears as the latter develops. Its place, however, remains empty, and can be found in the ripe seed separating the embryo and endosperm from the persistent nucellus above the chalaza. Thus, after having played the part of an absorptive structure the antipodal mass has a protective rôle preventing the digestion of the nucellus by the endosperm.

CHIFFLOT, J.—*Sur la Structure de la graine de Nymphæa flava* Leitn. (The structure of the seed of *Nymphæa flava* Leitn.)  
*Comptes Rendus*, cxxxvi. (1903) pp. 1584-6

### Physiology.

#### Nutrition and Growth.

**Alkaloids as a Source of Nitrogen.\***—L. Lutz, as a result of experiments with various fungi, concludes that alkaloids may serve as plastic material if sufficient nitrates are present; in the same way that an excess of carbohydrate enables a plant to make use of asparagin. The author points out that plants which are rich in alkaloids when grown in poor soil, become poor in alkaloids when grown in gardens or in a soil which is rich in nitrates.

**Nutrition of Chrysanthemums.†**—A. Hébert and G. Truffaut find, from manurial experiments with these plants, that phosphoric acid is of especial importance. The application of manures is only without effect when the soil contains at least 25 per cent. of total nitrogen, ·15 per cent. of phosphoric acid and ·125 per cent. of potash. On comparison of the produce obtained from unmanured soil with that from fully manured soil, the authors found that, whilst the total yield in the latter case was considerably increased, the percentage amounts of nitrogen and of the ash constituents were not materially altered.

**Germination of Orchids: a Symbiotic Relationship.‡**—N. Bernard has studied the germination of seeds of *Cattleya*, *Lælia*, and their hybrids. At the end of a fortnight, when sown on damp sawdust, the embryos form minute green spherules, in which condition they remain for some time. In some cases development does not advance further, and the plantlet is sooner or later destroyed by mould. In other cases, after a variable time which may reach one or two months, growth is resumed, but proceeds very slowly and irregularly; often after four or five months the plants do not exceed 5 mm. in length. They are top-shaped; at the larger end the terminal bud is formed, while at the narrower they are always found to be infested with a filamentous endophytic fungus. M. Bernard's experiments show that the presence of this fungus is a necessary condition of the development of the plantlet beyond the green spherule stage. He has not yet succeeded in determining the nature of this hyphomycetous fungus.

\* Bull. Soc. Bot. Fr., 1. (1903) pp. 118-28.

† Bull. Soc. Chim., ser. 3, xxix. (1903) pp. 619-23. See also Journ. Chem. Soc. lxxxiv. (1903) ii. p. 608.

‡ Comptes Rendus, cxxxvii. (1903) pp. 483-5.

## Irritability.

**Morphological Variation in Leaves of the Vine as a consequence of Grafting.**\*—A. Jurie has continued his study of the effect of grafting on the vine, and finds that well-marked modifications in the angle of the veins, in the general form of the leaf, and in the presence or absence of a tomentum, follow the grafting of certain vines on different American stocks. Thus, after ten years' growth on a glabrous-leaved American stock, the leaves of a Hungarian vine, which are naturally tomentose, are almost glabrous.

The instances cited illustrate a great variability in certain morphological characters of the vine leaf under the influence of the grafting operation. They show clearly that this influence is specific, and suggest a sort of asexual hybridisation between the two plants thus associated. They afford a further justification of M. Lucien Daniel's theory on variation in grafts.

## General.

**American Species of *Thinnfeldia*.**†—E. W. Berry gives a detailed description of the American species which have been referred to this genus. The genus was established by Ettingshausen to include certain fern-like fossils from the European Jurassic, which from their resemblance to the recent *Phyllocladus* he referred to the Coniferae. Much diversity of opinion has existed as to their true affinity. The American forms embrace two distinct types of plants. Those from the older Cretaceous beds, and from the Triassic, apparently represent true ferns comparable with the European type. But the middle and upper Cretaceous species are much larger-leaved plants, and some of them have a wide distribution, in contrast to the restricted distribution of members of the first type. These, the author is convinced, should be included in the coniferous family Taxaceae. They may perhaps form a link between the Podocarpeae and the Taxeae, and while they are unmistakably related to *Phyllocladus*, their large size and other differences suggest their reference to a new genus—*Protophyllocladus*—under which the author places three species previously described under *Thinnfeldia*. To the latter genus are restricted those species, of which the author recognises six in America, which are presumably of fern affinity.

**Revision of the Family Fouquieriaceae.**‡—G. V. Nash publishes a systematic revision of this small family of Dicotyledons, and discusses its affinities. As revised, it contains two genera: *Fouquieria*, with six species, and *Idria*, which is monotypic, and is confined to Mexico, the Southern United States, and Lower California. The order, which was considered by Bentham and Hooker in the *Genera Plantarum* as a tribe of Tamaricaceae, was separated by Engler on account of its oily endosperm and gamopetalous corolla. This separation is upheld on geographical grounds, the new order being confined to North America, while Tamaricaceae without it is strictly Old World. The author of the present revision suggests that its relationship is rather with Polemoniaceae among the Sympetalae.

\* Comptes Rendus, cxxxvii. (1903) pp. 500-2.

† Bull. Torr. Bot. Cl., xxx. (1903) pp. 438-45. ‡ Tom. cit., pp. 419-59.

**On the Characters of Hybrids.\***—C. Correns continues in a number of papers his investigations on the relation of the characters of hybrids to those of their parents. He points out that although many cases of supposed dominant characters on renewed examination have been shown to be unsatisfactory, yet a number of cases of absolute dominance still remain. A very good example is that of the hybrid between *Hyoscyamus annuus* × *niger*, where the biennial character of the latter parent is completely dominant over the annual character of the first. Also in the hybrid *Bryonia alba* × *dioica* the diœcious character of the one parent is completely dominant over the monœcious character of the other. The second case is of great interest as showing that the sex of the plant is not necessarily determined in the egg-cell before fertilisation, otherwise the pollen of *B. dioica*, which was used, would have had no effect. It shows also that the germ-cells of the diœcious plant possess some male characters, others female, as the diœcious hybrids produced were of both sexes. Correns, in a further paper, points out that the statement of De Vries, that Mendel's law holds for the characters of varieties, while the characters of species on crossing become blended, does not hold generally. In a third paper the same worker reviews the various observations on hybrids which have appeared during the year ending in the autumn 1902.

**Colours of Northern Gamopetalous Flowers.†**—J. H. Lovell concludes his observations on this subject, and arrives at the following conclusions. The colours of flowers have been determined by their utility rather than by an æsthetic colour-sense in insects, which distinguish between different colours but do not receive greater pleasure from one hue than from another. Any preference they may manifest has arisen from the association of the colours with the presence of food-substances. Conspicuousness, or contrast of the inflorescence with the foliage, has been induced by insects, to which it is of advantage, as it enables them to find nectar-bearing flowers quickly, while it aids the plants in securing cross-pollination. Many colours are better than one, since the flowers are rendered more conspicuous by contrasts with each other as well as with the foliage, and insects are less liable to visit them indiscriminately. The sequence of colours, green, yellow, white, red, purple, and blue, depends upon physiological causes. Plants vary greatly in their capability of forming the different pigments, and the floral colours are correlated with the variability of this function. The primitive colours, green, yellow, and white, have been determined by the nature of the chloroplast and its pigment content; while red, purple, and blue have arisen as the result of various chemical and physical conditions.

**Botany of the Ceylon Patanas.‡**—J. Parkin and H. H. W. Pearson give an account of the anatomical characters of the plants collected by Mr. Pearson on the montane grass-lands of Ceylon, and discuss the relation of these characters to the conditions under which the plants grow. They find that the anatomical characters bear out the result of field observations, in indicating a xerophytic habit. It is of interest to note that these characters are equally well shown in plants from both the

\* Ber. Deutsch. Bot. Ges., xxi. (1903) pp. 195-210; Bot. Zeit., lxi. (1903) pp. 116-126.

† Amer. Naturalist, xxxvii. (1903) pp. 443-79.

‡ Journ. Linn. Soc., xxxvi. (1903) pp. 430-63 (2 pls.).

wet and dry patanas, and it is suggested that some factor in the climate of the wet patanas, tending to the evolution of xerophytic characters, may have been overlooked, or its influence undervalued. Such a factor may be presented by the prevalent wind, which by constantly changing the air prevents its approaching but rarely a state of saturation. Again, sufficient importance may not have been ascribed to the lowering of the functional activity of the roots of the wet patana plants by the humic acid in the soil.

BURKILL, I. H.—On the Variation of the Flower of *Ranunculus arvensis*.

*Journ. Asiat. Soc. Bengal*, lxxi. (1902) pp. 93-120 (with diagram and 29 tables)

PARSONS, H. FRANKLIN—On the Flora of Hayes Common.

[Including list of plants.]

*Proc. and Trans. Croydon Nat. Hist. and Sci. Soc.*, 1902-3 (1903) pp. 52-60.

## CRYPTOGAMS.

### Pteridophyta.

**Cytology of Apogamy.\***—J. B. Farmer, J. E. S. Moore, and L. Digby describe certain phenomena in apogamous prothallia of *Nephrodium*, which afford an explanation of apogamy. In young prothallia, before the appearance of any apogamous outgrowths, cells not infrequently occur in which two nuclei are present. This is found to be due to the passage of a nucleus from a neighbouring cell; the migrating nucleus may fuse with the original nucleus, or the two nuclei may remain more or less separated for an appreciable time. This migration goes on discontinuously in a growing apogamous prothallium, producing a cellular aggregate that may possess no very homogeneous character, nor can one cell or even isolated cell-groups be defined as the sole parent tissue from whence the apogamous outgrowth may have sprung. This is in harmony with the irregular growth of the new tissue and with the sporadic appearance of sporophytic members on the prothallium. When the nuclei of the cells in the apogamous regions are examined in course of karyokinesis they are seen to possess a much larger number of chromosomes than those of the ordinary tissue-cells of the prothallium; there appear to be forty and eighty in the respective classes of nuclei. The authors regard the process as one of irregular fertilisation. The doubling of the chromosomes receives an explanation strictly analogous to that afforded by the normal fusion of oosphere and spermatozoid. But instead of one cell only (the oospore) serving as the starting point for the new generation, a number of such units loosely co-operate to produce it. In this connection it is perhaps significant that the young plantlet is commonly borne on, and produced from, a special sporophytic outgrowth, of which the constituent cells may have become homologously differentiated into a sort of pro-embryo.

**East Asiatic Pteridophyta.†**—Y. Yabe gives a list of 53 vascular cryptogams collected in Korea by T. Uchiyama. H. Christ ‡ publishes a list of 33 species collected by E. H. Wilson mostly in Hupeh, with descriptions of four novelties.

\* *Proc. Roy. Soc.*, lxxi. (1903) pp. 433-7 (4 figs. in text).

† *Tokyo Bot. Mag.*, xvii. (1903) pp. 63-9.

‡ *Bull. Herb. Boiss.*, ser. 2, iii. (1903) pp. 508-14.



**North American Pteridophyta.\***—W. R. Maxon publishes notes on a form of *Woodwardia spinulosa*, *Adiantum modestum*, and a new sub-species of *Polystichum munifolium* from Guadalupe Island, Mexico. A. A. Eaton † gives an account of *Equisetum levigatum* and its varieties. A. V. Osmun ‡ describes some characteristics of *Equisetum scirpoides* and its habitats, and regards it as less rare than has been supposed. W. N. Clute § gives a list of 222 ferns collected in Jamaica. J. Reverchon || records 51 ferns and 15 fern-allies as occurring in Texas. B. F. Bush ¶ has compiled a list of 59 ferns from the same State with habitats. A. A. Eaton \*\* publishes a critical and historical note on *Isoetes riparia* var. *canadensis* and *I. Dodgei*, which he finds to be identical, and which he unites under A. Braun's Ms. name *I. canadensis*. H. L. Lyon †† gives a list of 60 pteridophytes of Minnesota, five of which are new records for the State.

### Bryophyta.

**Development of Spermatozoids in Marchantia.††**—Ikeno has investigated the development of the antherozoids in *Marchantia polymorpha* with especial relation to the occurrence of centrosomes and their relation to cilia formation. Centrosomes were observed clearly in the inner cells of the antheridium. The centrosome appears first as a body inside the nucleus; it wanders out of the nucleus and divides into two bodies which take up opposite positions on the rounded nucleus. The nucleus becomes elongated in relation to the centrosomes, and between the latter spindle-fibres begin to appear, which on the disappearance of the nuclear wall make their way into the nuclear cavity and form a complete spindle. The centrosomes disappear at the end of the division; whether they are dissolved in the cytoplasm or taken up by the nucleus is doubtful. After the division which separates the sperm-mother-cells the centrosomes, however, do not disappear but take on the function of blepharoplasts, that is, the centrosome moves to the periphery of the cell, becomes elongated, and develops the two cilia. The author finally discusses the question of the nature of the centrosome and blepharoplast.

**European Mosses.§§**—W. Limpricht continues the supplement to *Die Laubmoose* of his late father, K. G. Limpricht, advancing the work from *Bryum* to *Hypnum*, gathering up the various additions that have been published since the main text was printed. A. Mansion and J. Ch. Sladden ||| publish descriptive and critical notes on *Racomitrium sudeticum* and *Grimmia atrata*, additions to the Belgian flora. A. Hansen ¶¶

\* Fern Bulletin, xi. (1903) pp. 38-40. † Tom. cit., pp. 40-44.

‡ Tom. cit., pp. 44-6.

§ Tom. cit., pp. 54-9.

|| Tom. cit., pp. 33-8.

¶ Bull. Torrey Bot. Club, xxx. (1903) pp. 343-58.

\*\* Tom. cit., pp. 359-62.

†† Minnesota B. t. Studies, ser. iii. (1903) pp. 245-55.

‡‡ Beih. Bot. Centralbl., xv. (1903) pp. 65-88 (3 pls., 1 fig. in text).

§§ Rabenhorst's Kryptogamen-Flora, iv. 3, Lief. 39 (1903) pp. 769-832.

||| Bull. Soc. R. Bot. Belg., xli. 2 (1903) pp. 48-55.

¶¶ Bot. Tidsskr., xxv. (1903) pp. 243-51.

gives a list of 235 mosses gathered in the north-east of the island of Fyen. Seven of the species are new to Denmark. L. Corbière\* gives a list of mosses and hepatics gathered in Haute-Savoie by Gasilien. A. Casares Gil † describes and figures the fructification of *Homalia lusitanica* found by him near Barcelona.

**Weisia sterilis** sp. n. ‡—W. E. Nicholson describes this new British moss. It occurs on the chalk downs of the south-eastern counties, and belongs to the subgenus *Systegium*.

**Thamnum**.§—N. C. Kindberg discusses the history of this genus, and shows that as a generic name *Thamnum* has precedence of *Poro-trichum*.

**American Mosses**.||—E. G. Britton gives some notes on West Indian mosses which have been found in Florida. R. S. Williams ¶ describes a new *Brachythecium* from the upper Yukon river and gives a list of 15 others not previously recorded from that district. A. J. Grout\*\* describes the development of the peristome of *Mnium hornum*, and employs the new generic name *Burnettia* for *Homalothecium subcavillatum*. J. M. Holzinger, †† reporting on the moss-flora of the Minnesota River, gives a list of 96 species, of which 44 are new to the State and 6 are new to science. J. Cardot ‡‡ describes two new species of *Fontinalis*, gathered in Minnesota.

**West African Mosses**.§§—E. Paris describes 8 new species of mosses from French Guinea in West Africa.

**British Hepaticæ**.|||—G. Stabler has drawn up a localised list of 99 hepatics gathered near Balmoral in Aberdeenshire during the summers of 1884 and 1894. S. M. Macvicar ¶¶ gives a localised list of 102 hepatics gathered in June 1902 in the Lochcarron District of West Ross-shire. *Geocalyx graveolens*, a marsupiid species, is an addition to the British Flora. H. W. Lett\*\*\* found *Scapania intermedia*, a new record for Ireland, at an altitude of 1800 ft. on Galtee More Mountain, S. Tipperary, in July 1902, and subsequently discovered it in a collection made in Co. Antrim fifteen years previously.

**European Hepaticæ**.†††—I. Douin has discovered *Jungermannia Kunzeana* in Auvergne, an addition to the French flora. A. Crozals ‡‡‡ describes *Riccia subbifurca* Warnst., a new species found at Fontainebleau and in Vienne. He also makes some remarks on *Lejeunea*

\* Mem. Pont. Ac. Rom. Nuov. Lincei, xxi. (1903) 14 pp. See also Rev. Bryol., 1903, p. 78.

† Bull. Soc. Españ. Hist. Nat., iii. (1903) pp. 242-44 (figs. in text).

‡ Journ. Bot., xli. (1903) pp. 247-8.

§ Hedwigia, xlii. (1903) Beibl., pp. 169-71.

|| Bryologist, vi. (1903) pp. 58-61.

¶ Tom. cit., pp. 61-2.

\*\* Tom. cit., pp. 63-5.

†† Minnesota Bot. Studies, ser. iii. (1903) pp. 109-27 (with plates).

‡‡ Tom. cit., pp. 129-31 (with plates).

§§ Rev. Bryol., xxx. (1903) pp. 66-9.

||| Trans. and Proc. Bot. Soc. Edinburgh, xxii. (1902) pp. 249-54.

¶¶ Ann. Scott. Nat. Hist., 1903, pp. 175-80.

\*\*\* Journ. Bot., xli. (1903) p. 286. ††† Rev. Bryol., xxx. (1903) p. 61.

‡‡ Tom. cit., pp. 62-5.

*Rossettiana*, the antheridia of which he has discovered. The plant is autoicous. A. Martin\* gives a list of hepatics gathered in the department Hautes-Pyrénées. A. J. M. Garjeanne† has studied the hepatics of the Netherlands for five years and gives a list of 78 species, indicating the provinces in which they occur. C. Massalongo‡ gives a critical revision of the hepatics published in the *Erbario Crittogamico Italiano* by De Notaris, twenty-five years ago. S. S. Radian§ describes *Bucegia romana*, a new thalloid genus gathered in the Carpathians. V. Schiffner|| gives a critical and historical account of *Dichiton calyculatum*, a rare African hepatic which, discovered 60 years ago in Algeria only once, has recently been found in the south of France, and is thus an addition to the European flora.

**Gymnomitrium and Marsupella.**¶—V. Schiffner publishes some studies on critical species of these two genera. He finds *Marsupella Sprucei* to be distinct from *M. ustulata*; refers *M. olivacea* to *Gymnomitrium adustum*; describes as a new species *M. (Hyalacme) apiculata*, which Lindberg and others wrongly referred to *G. condensata* Angstr.—this latter being also a *Marsupella* and synonymous with *Sarcoscyphus æmulus* Limpr.; and shows that *S. alpinus* Gott. is a true *Gymnomitrium*.

**North American Hepaticæ.\*\***—A. W. Evans in enumerating the hepatics of the Yukon district, 38 in number, raises to generic rank *Mesoptychia*, Lindberg's section of *Jungermannia*. The same author†† gives a list of 32 hepatics of Minnesota, 16 of which are new to that State, and 3 have not been recorded previously south of the Canadian frontier. The same author‡‡ also publishes lists of the hepatics that occur in each of the six States of New England.

YOSHINAGA, T.—**Japanese Hepaticæ.**

[A list of 16 hepatics from Tosa and Nikko, 7 of which are new.]

*Tokyo Bot. Mag.*, XVII. (1903) pp. 37-39.

GEHEEB, A.—**Was ist Bryum Geheebii C. Müll.? Und wo findet es im Systeme seine natürliche Stellung? Eine bryologische Studie.** (What is *Bryum Geheebii* C. Müll., and where should it be placed in a natural system? A bryological study.)

[Distinct from *B. Funckii* and *B. Gerwigii*, perhaps allied to *B. gemmiparum*, but fruit unknown.] *Beih. Bot. Centralbl.*, XV. (1903) pp. 83-94.

### Algæ.

**Marine Algæ of the Shetlands. §§**—F. Børgesen publishes a list of 75 species from these islands, including all previous records as well as the results of his own gatherings. Comparisons are drawn between this flora and that of the Faeröes, together with notes on the local distribution of certain species.

\* *Rev. Bryol.* xxx., (1903) pp. 73-6.

† *Tom. cit.*, pp. 70-3.

‡ *Acc. Sci. Ferrara*, 1903, 20 pp., 10 figs. See also *Rev. Bryol.*, xxx. (1903) p. 80.

§ *Bull. Herb. Inst. Bot. Bucarest*, 1903. See also *Rev. Bryol.*, xxx. (1903) p. 77.

|| *Oesterr. Bot. Zeitschr.*, liii. (1903) pp. 137-40.

¶ *Tom. cit.*, pp. 95-9, 166-72, 185-94, 246-52, 280-4 (3 pls.)

\*\* *Ottawa Naturalist*, 1903, pp. 13-24 (2 pls.).

†† *Minnesota Bot. Studies*, ser. iii. (1903) pp. 141-4.

‡‡ *Rhodora*, v. (1903) pp. 170-3.

§§ *Journ. Bot.*, xli. (1903) pp. 300-6.

**Phytoplankton of Lakes in the Faeröes.\***—F. Børgesen and C. H. Ostenfeld have investigated certain lakes in these islands and give a list of the phytoplankton found in them. The species are enumerated in two tables, one containing the species recorded from Sörvaagsvatn at different times, and the other containing all the species recorded from eight different lakes. The authors regard the result of their investigations as very poor. Certain species of desmids and other Chlorophyceæ, as well as the diatom *Cyclotella* were often found to be surrounded by a mucilaginous envelope. Special notes and remarks are made on certain species, including one new to science, *Staurastrum Magdalene*.

**Japanese Marine Algæ.†**—K. Okamura has issued a second fasciculus of the algæ of Japan, and he publishes a list of them in which he describes the new species and varieties. The new species are *Cylindrocarpus rugosa* and *Chaetomorpha spiralis*. Some alterations are made in the nomenclature of other species, the reasons for which are stated.

**New Genera of Diatoms.‡**—C. Mereschkowsky describes two new genera, *Placoneis* and *Staurophora*. The former is composed of species which have till now been included in the genera *Pinnularia*, *Navicula*, and *Stauroneis*. The internal structure of these species differs however from that of the genera in which they had been placed, and they are accordingly placed in the two new genera. Their principal characteristic lies in the combination of a symmetrical structure and form of the frustules with a single asymmetrical endochrome body. Each species of the new genera is treated separately, and synonymy, description, and geographical distribution are given, often followed by critical notes. In remarks on the relationships of the two new genera, a list is given of the species of *Navicula* which have to be removed to *Placoneis* and *Staurophora*, as well as a table of descent connecting species of *Cymbella* with *Placoneis dicephala*. The author regards *Placoneis* as the missing link between symmetrical and asymmetrical Pyrenophoreæ, the latter being descended from the former. Finally a key is given to the genera of the Pyrenophoreæ, and a list of the groups and species of *Navicula* which must be excluded from that genus, together with their new and correct designations.

**Diatoms from Morocco.§**—E. Belloc gives a list of 97 species and 17 varieties gathered principally at Mogador and Tangier. The genera represented are 32. *Navicula* contains the greatest number of species, 38; followed by *Amphora* with 19. There are no novelties.

CHAPMAN, F., & H. J. GRAYSON—On "Red Rain," with special reference to its occurrence in Victoria.

[Includes a list of Diatomaceæ in the sediment collected at St. Kilda on March 28th, 1903.] *Victorian Naturalist*, xx. (1903) pp. 17-32 (2 pls.).

\* Botany of the Faeröes, ii. (1903) pp. 613-24 (4 figs.).

† Bot. Mag. Tokyo, xvii. (1903) pp. 129-32.

‡ Beih. Bot. Centralbl., xv. (1903) pp. 1-30 (1 pl. and 14 figs. in text).

§ Compt. Rend. Cong. Soc. Savantes, 1903, pp. 143-50. See also Bot. Centralbl., xciii. (1903) p. 301.

## Fungi.

**Fertilisation in *Plasmopara*.**\*—O. Rosenberg finds a great similarity in the formation of the fruit between this fungus and the other members of the Peronosporæ that have been examined. The oogonium at an early stage is seen to be filled with protoplasm, interspersed with many small vacuoles, and contains about 45 nuclei each with a definite nucleolus and chromatin. The antheridium contains about 5 nuclei and is pressed against the oogonium. A slight bulging of the oogonium into the antheridium, forming a receptive papilla, takes place, and later the nuclei in both organs undergo mitotic division. Those of the oogonium wander towards the periphery, one only, as a rule, remaining in the denser protoplasm of the centre. The cœnocentrum makes its appearance simultaneously with the nuclear division. The central nucleus also divides, the daughter-nucleus passing outwards. The nuclei all divide a second time, and the sister nucleus in the centre gradually disintegrates. Owing probably to changes in turgidity the receptive papilla is withdrawn and a protrusion arises from the antheridium which penetrates the oosphere. One nucleus alone passes into the oogonium. The writer adds details of the mitotic process. The resting structure resembles the spirem stage of the higher plants. Before division the nucleolus takes a lenticular shape, the *Sichelstadium*, and the chromatin comes to lie in a ball at the side of the nucleus representing the synapsis stage. The nuclear spindle is formed from the network of the nucleus, and the division of the chromosomes takes place at the equator. The resulting nuclei are smaller and lose their nuclear membrane at an early stage of their subdivision. Rosenberg thinks that the *Sichel* and *synapsis* stages indicate a reduction of chromosomes, and that the double division is akin to the tetrad division of the higher plants.

**Action of Fermentation on the Cell.**†—L. Matruchot and M. Molliard conclude their study of the changes induced in the cell by the fermentation process. They repeat in beetroot and onion the observations already made on those of the pumpkin. They also studied the changes in the cells of *Mucor racemosus*, a fungus which itself produces fermentation. The nuclei increased to twice their original size, as in the cells of the higher plants, and decreased in number with cell-division, so that each cell of the filament contained finally one or at most two nuclei. Some cells were even non-nucleate.

**Spore-Formation in Mucorini.**‡—Deane B. Swingle gives the result of his study of two members of the group *Rhizopus nigricans* and *Phycomyces nitens*. He notes first the formation of denser contents, cytoplasm and nuclei, towards the sporangium wall, followed by the appearance of large vacuoles in the denser protoplasm parallel to its inner surface. After the formation of the columella, furrows are formed inward from the surface and outward from the columella, both systems

\* Bihang K. Vet. Akad. Handl., iii. (1903) No. 10, 20 pp. (2 pls.).

† Rev. Gén. Bot., xv. (1903) pp. 310-27.

‡ U.S. Dept. of Agric.; Bureau of Plant Industry; Bull. No. 37 (1903) pp. 1-40 (6 pls.). See also Bot. Centralbl., xciii. (1903) p. 259.

repeatedly branching to form multinucleate bits of protoplasm surrounded by plasma membranes and separated by spaces filled with cell-sap only. Later follows the formation of walls about the spores and columella. There are slight differences in the process between the two fungi examined.

**Zygosporos of Mucorini.**\*—Paul Vuillemin insists on the taxonomic importance of these spores in reference to the formation of their appendages. He describes the various members of the family, and draws up a table based on his theories. He has made two new genera, *Proabsidia* and *Zygorhyncus*, the latter distinguished by the peculiar form of the zygosporos.

In another paper the same author † discusses *Tieghemella* and the series of Absidia, all of which are distinguished by the formation of stolons. He includes the genera *Proabsidia*, *Lichtheimia*, *Mycocladius*, *Tieghemella*, and *Absidia*. *Lichtheimia* is a new genus with 3 species, formerly classified under *Mucor*, *M. corymbifera*, *M. Regnierii*, and *M. ramosa*.

**Systematic Position of *Monascus purpureus*.**‡—S. Ikeno reviews the work done on *Monascus* by Went, and more recently by Barker. The latter received it as the "Samsu" fungus from the Malay Peninsula, described its development, and as a result of his observations placed it among the Ascomycetes, therein disagreeing with Went, who had classified it among the Hemiasci.

Ikeno has studied *Monascus* anew. He did not find any asci, but followed the development of the spores by free cell-formation within a sporangium. Barker's "Samsu" fungus does not agree with this description and, according to Ikeno, should be removed from the genus *Monascus*.

***Boletus subtomentosus*.**§—Ch. Ed. Martin writes a complete monograph of this variable species as found in the neighbourhood of Geneva. He describes 11 sub-species and includes among them *B. chrysenteron*. He finds that the fungus varies according to habitat and that there is no type form common to all regions.

**Infection Experiments with *Claviceps*.**||—Rob. Stäger experimented with two species of this fungus: the well-known ergot of rye, *C. purpurea*, which grows on a large number of grasses, and *C. microcephala* which is parasitic on *Phragmites communis*, *Molinia cærulea*, and *Arundo Calamagrostis*. The latter differs anatomically from *C. purpurea*, and the distinction was borne out by the infection experiments. As regards *Claviceps purpurea*, it was found that *Anthoxanthum odoratum* was easily infected and made to produce the *Sphacelia* stage, the conidia of which were used for infecting other grasses. Sclerotia were however rarely developed. A large number of grasses were successfully infected by the parasite from the rye, but *Poa fertilis* and *P. annua* were immune, as also *Lolium perenne*, *L. italicum*, *Glyceria fluitans*, *G. distans* and *Bromus erectus*. It was found that *Bromus sterilis* grew the fungus

\* Bull. Soc. Mycol. France, xix. (1903) pp. 106-26.

† Tom. cit., pp. 119-27 (1 pl.).

‡ Ber. Deutsch. Bot. Ges., xxi. (1903) pp. 259-69 (1 pl.).

§ Matériaux pour la Flore Cryptogamique Suisse, II. fasc. 1 (1903) 39 1 p. (18 coloured pls.).

|| Bot. Zeit., lxi. (1903) pp. 111-58.

readily from the spores. Stäger considers that he is here dealing with a biological race or races, as the ergots on these grasses are morphologically identical. He records a further series of experiments with an ergot found on *Glyceria fluitans*. A large number of grasses were again infected with the spores, but only negative results were obtained with these, while the plants of *Glyceria fluitans* infected at the same time produced the sphaecelia stage and later the sclerotia of the fungus. Stäger thinks that this ergot is probably identical with *Claviceps Wilsoni* Cooke, recorded in England on the same grass, though hitherto the form found in Germany has been considered to be *C. purpurea*. Experiments with ergot taken from *Lolium* resulted in the infection of species of *Lolium* and *Bromus erectus* alone. The *Claviceps* of *Poa annua* could not be transferred to any other host. *Brachypodium silvaticum* has also an ergot that is confined to that one host so far as results have shown from the experiments undertaken. The author gives a list of insects that aid in the dissemination of the spores; they are attracted in large numbers by the honey-dew of the sphaecelia stage.

**Observations on the Ergot of *Claviceps purpurea*.**\*—C. Engelke obtained pure cultures from the ascospores of the fungus. The developing mycelium broke up into conidia and with these he carried out further infection experiments. These were only successful when made before pollination of the stigma. The hyphæ of the fungus penetrated from the stigma to the developing ovule at the base of the ovary, and there the formation of the sclerotium began. No infection took place through the stomata. The honey-dew of the sphaecelia stage is but an increased production of fluid by the stigma, owing to the irritation of the tissue by the fungus. It is not a product of the fungus, and is never produced in artificial cultures. The writer proposes to study the substances formed by the fungus in the cultures with a view to the artificial production of those used in medicine.

**Relationship between *Pleospora* and *Helminthosporium*.**†—H. Diedicke has followed up a previous research on this subject by further observations and cultures. He had established the connection between the two fungus forms and had identified *Pleospora trichostoma* as the higher form of *Helminthosporium gramineum*. He finds now that the determination was too general, that on the different grasses there are a number of *Pleosporæ* as *Pl. teres*, *Pl. Avenæ*, *Pl. Bromi*, *Pl. graminea*, *Pl. Tritici-repentis*, each with its own form of *Helminthosporium*. From cultures and infections of *Pl. trichostoma* on rye he obtained *Alternaria* as the conidial form.

**Studies of *Erysiphææ*.**‡—F. W. Neger has devoted special attention to the function and behaviour of the perithecial appendages of several forms of *Erysiphææ*. He finds that they are hygroscopic and by torsion movements have an important influence in releasing the ripened fruit-bodies.

**Yeast-forms of Fungi.**§—H. Will has studied the different forms of budding fungus cells that occur in connection with brewing. He has

\* Zeitschr. angew. Mikr., ix. (1903) pp. 63-5.

† Centralbl. Bakt., x. (1903) pp. 52-9.

‡ Tom. cit., pp. 570-3.

§ Tom. cit., pp. 689-700.

isolated 17 different forms which he has found in or on the vats, in the building, or even in the air. He describes the appearance of these, in none of which has he detected any approach to spore-formation, thus separating them conclusively from *Saccharomyces*. He gives the results of his experiments to test the influence of these foreign organisms on the process of brewing. At low temperatures their growth is much retarded. A quite considerable effect on the taste and odour of the wort was produced by the presence of one or another of the organisms; a slight decoloration was also noticeable. No influence on the acidity of the wort was detected. Other tests were tried, and the final conclusion came to was that no injury to brewing need be feared from the accidental presence of these fungi, as with the increase of the true yeast their growth and development are retarded or altogether stopped.

**Cucumber Leaf Disease.\***—A new disease of the cucumber plant has made its appearance quite recently. It is due to a mould *Dendryphium comosum*, hitherto known only as a saprophyte. The fungus mycelium penetrates the tissue of the leaves and destroys it, in smaller or larger areas. In bad cases the young shoots and fruits are utterly ruined by the fungus. Advice is given as to prevention and cure.

**New Disease of *Asclepias curassavica*.†**—G. Scalia describes a new parasitic genus *Oidiopsis* which does serious damage to the plants of *Asclepias*. The fungus lives in the tissue of the plant. The sparsely branched conidiophores pass out through the stomata and bear chains of colourless conidia. It resembles *Oidium*, but differs from that fungus in its endophytic character.

**Rhizoctonia violacea.‡**—This fungus, a sterile mycelium, causes a root-disease of various plants. Jakob Eriksson records its appearance at the Swedish Experimental Station, where it attacked a field of carrots. A large number of experiments was made with a view to testing the capability of the fungus to transfer itself from one host to another. On diseased soil were planted several varieties of carrots and beets, clover, lucerne and potatoes, of which some were attacked while others escaped the disease. A tub of strongly infected soil was left standing and there grew in it a series of weeds, *Sonchus*, *Myosotis*, *Urtica*, *Stellaria*, &c. On the roots of all of them the fungus was found to be growing more or less vigorously. The writer is of the opinion that the fungus does exercise some choice as to its host and that it will take several generations to accustom it to a new plant. He tested and proved this theory on sugar-beets. The attack of the fungus infected from carrot was already much stronger in the second generation. Experiments were made with the view to killing the fungus. Lime was added and carbolic acid; the results are unsatisfactory so far.

A severe attack of the same fungus on sugar-beets is recorded by Fr. Bubak.§ He blames the heavy and wet condition of the soil for

\* Journ. Board of Agric., x. (1903) pp. 166-70 (1 pl.).

† Agricolt. Calabro-Siculo, xxvii. (1903) No. 24. See also Centralbl. Bakt., x. (1903) pp. 71-2.

‡ Centralbl. Bakt., x. (1903) pp. 721-38 (3 figs.).

§ Zeitschr. Zuckerind. in Böhmen, xxvii. (1903) p. 471. See also Centralbl. Bakt., x. (1903) p. 747.



the extension of the disease. There was also a large quantity of manure laid down, forming a rich nutriment for the fungus. The roots attacked were completely invested by the mycelium; scarcely a sound spot was left. The writer tried treatment with lime to exterminate the disease, without much effect. He recommends better draining of the soil, destruction of all diseased plants, and a change of crop for a number of years.

**Aspergilleæ Parasitic on Human Beings.\***—Bojana Mirsky developed in artificial cultures *Sterigmatozystis versicolor* isolated from the sputum of a tuberculous patient. It grew only at low temperatures and formed rose-coloured patches as well as the usual green-coloured tufts.

**Notes on Uredineæ.†**—Fr. Bubak has proved by experiments that the *Adoxa æcidium* is not a form of *Puccinia Adoxæ* but of *P. argentata*, the uredo form of which grows on *Impatiens noli-tangere*.

P. Magnus ‡ contributes notes of his observations on the occurrence of the chrysanthemum rust in Europe. It is due, he thinks, to uredospores rather than to teleutospores. He cites cases where uredospores have been the agents of propagation.

F. Bubak § publishes a preliminary note on *Uredo Symphyti*, the æcidium form of which he produced on *Abies alba*.

E. W. Holway || advises as to the best methods for collecting and preserving specimens of Uredineæ, placing them in herbaria, mounting slides, &c.

H. Diedicke ¶ has made culture experiments with *Puccinia Stipæ*. It forms æcidia on species of *Thymus* and also on *Salvia silvestris*.

**Mycoplasma Hypothesis.\*\***—J. Eriksson publishes a reply to Marshall Ward's criticism of his work on Uredineæ. He had found evidence for the growth of rust pustules without external infection in plants that had been carefully kept from risk of spore contamination; and in the tissues of these plants he found what he considers to be the hyphæ developing from the mycoplasma of the plant. Marshall Ward had pronounced these to be the cut-off ends of haustoria, and Eriksson answers him and points out that Ward was in each case dealing with directly infected material, whereas the bodies he described could only occur in connection with pustules that had developed from the mycoplasma in the plant itself.

**Changes produced in the Peridial Cell-Walls of the Uredineæ.††**—Oscar Magnus concludes his observations and experiments on this subject. He finds that within a given species great variations may occur. In a sunny locality the cell-wall is strongly developed; in the shade the lumen of the cell is comparatively much larger. He finds that this development goes on parallel lines with the formation of the leaf-tissue, with one exception, that of *Æcidium Aconiti-Napelli*. He did not find

\* Thèse de l'Univ. de Nancy, 1903, 76 pp. See also Bot. Centralbl., xciii. p. 271.

† Centralbl. Bakt., x. (1903) p. 574.

‡ Tom. cit., pp. 575-7.

§ Ber. Deutsch. Bot. Ges., xxi. (1903) p. 356.

|| Journ. Appl. Micr., v. (1902) pp. 2075-6.

¶ Ann. Mycol., i. (1903) pp. 341-3.

\*\* Arkiv. Bot. K. Svensk. Vetenskapsakad., i. (1903) pp. 139-46.

†† Centralbl. Bakt., x. (1903) pp. 700-21 (27 figs.).

that the cells varied with the host, when the Puccinia occurred on several different species.

**Clamp-Connections and Fusion in the Uredineæ.\***—W. Voss has undertaken to supply the gap in our knowledge as to the occurrence of cell-fusions in the Uredineæ, many examples having been already noted in the Ascomycetes and Basidiomycetes. He treated the sections of the leaf and parasite with a solution of 1 p.c. osmic acid for about 10 minutes, which hardened and slightly darkened the fungal hyphæ; afterwards he examined them in chloral hydrate. He found numerous examples of cell-fusion, and also clamp-connections in all the species of Uredineæ that were examined. The unfinished clamp-wall always terminated in a slight swelling, and he found further that the completed wall showed pits allowing the continuation of the protoplasm. Clamp-connections have only been detected in the Basidiomycetes and the most highly developed Ascomycetes; that is, in forms that express a high stage of development. They must therefore be a property of forms with a long evolutionary history, and Voss concludes from this that the Uredineæ branched off from the main fungus stem at an early stage and have reached their present form after a long course of development.

**Taxonomic and Cytological Notes on Botryosporium pulchellum.†** This fungus has been described under a variety of names. René Maire discusses these and finally leaves it as *B. longibrachiatum* (Ond.) R. Maire. He takes occasion to give the results of his examination of the plant when first observed by him, especially with reference to the formation and function of the metachromatic corpuscles. The plant consists of an axis rising from the creeping filaments and furnished with lateral branchlets which bear heads of spores. The cells of the developing axis and branchlets are filled with a dense cytoplasm with numerous nuclei difficult to stain. No metachromatic corpuscles were present. At a later stage the nuclei are more easily coloured, and division by mitosis was noted in the heads of the branches that bear the conidia. They were too minute to allow details to be followed. At the stage of conidia formation, metachromatic granulations were present, and crystals which later also became metachromatic granulations. As the conidia form, the cytoplasm, the metachromatic granulations and finally a nucleus pass in. The conidium then drops off and the branchlets are seen to contain only cytoplasm and a few nuclei which degenerate. There are no metachromatic corpuscles. They are, however, very numerous in the cells of the main axis at the base of the branchlets. These observations made by Maire incline him to adopt Guilliermond's theory that these bodies are secretions of reserve material having the same physiological significance as starch-grains, crystals, &c.

**Nuclear Behaviour and Spore-Formation in Hydangeum carneum.‡**—Van Bambeke gives a preliminary account of his observations on the cytology of this form, and criticises the work of Istvanffi, Petri, and Ruhland. The subhymental cells show constantly two nuclei

\* Ber. Deutsch. Bot. Ges., xxi. (1903) pp. 366-71 (1 pl.).

† Ann. Mycol., i. (1903) pp. 335-40.

‡ Bull. Cl. Sci. Acad. Roy. Belg., 1903, pp. 515-20.

(synkarion) which divide at the same time (conjugate division). The young basidia are always binucleate and at their moment of fusion are in the spirem stage. The fused nucleus soon divides and shows a well-marked spindle with centrosomes; at first a number of chromatin granules are present (protochromosomes of Maire), but these soon unite into two definite chromosomes. By a later division four nuclei are formed, but typically only one or two sterigmata are produced, into each of which a single nucleus travels. The nucleus of the basidiospore very soon divides, so that the mature spore may contain as many as eight nuclei.

**Diseases of Grasses.\***—L. H. Pammel, J. B. Weems, and F. Lamson-Scribner have included in their account of the grasses of Iowa an enumeration of the most important of their fungus diseases found in the territory. The seedlings were liable to injury by such moulds as *Penicillium glaucum*, &c.; the older plants were attacked by bunts, smuts, rusts, and various other more or less well known fungi, all of which are recorded. Several cases of loss were due to the action of bacteria.

**Mycological Notes.†**—C. Massalongo finds that the leaves of *Quercus pubescens* are destroyed by *Glæosporium nervicolum*; that anthracnosis of the leaves of *Populus tremula* was caused by the attack of a fungus corresponding to *Fusicladium Tremulae* Frank., but more correctly named *Napicladium Asteroma*. According to Vuillemin it is the conidial stage of *Didymosphaeria populina*. The writer also describes a new Hyphomycete *Fusarium lichenicolum*, which he found parasitic on the thallus of the lichen, *Candelaria vulgaris*.

**Metachromatic Corpuscles in the Ascomycetes.‡**—M. A. Guilliermond proves anew by his researches on *Ascobolus marginatus* that these corpuscles are reserve-materials. The spores at their first formation in the ascus are small bodies with a fine membrane; gradually, as the spore matures, it absorbs the surrounding cytoplasm, the glycogen, and the metachromatic corpuscles, which are present in great abundance.

**British Microfungi.§**—A. Lorrain Smith publishes a descriptive list of species new to science or of rare occurrence. There is one new genus *Ampullaria*, a member of the Nectrioidaceæ, distinguished by the dark brown spores. The writer resuscitates the genus *Brachycladium* of Corda to include species with non-catenulate spores that have been placed in *Dendryphium*. The latter genus contains forms with spores borne in chains at the tips of the fertile hyphæ.

**Mycorrhiza.||**—P. E. Muller notes two forms on the roots of Mountain Pine. Besides the usual racemosely branching roots, he found some that branched dichotomously with little tubercles. These are peculiarly abundant in sandy soil and are doubtless agents for absorbing nitrogen.

\* Iowa Geological Survey. Des Moines (1901). 525 pp., 220 figs., 3 col. pls. See also *Centralbl. Bakt.*, x. (1903) p. 72.

† *Malpighia*, lx. (1903) pp. 419-23.

‡ *Comptes Rendus*, cxxxvi. (1903) pp. 253-55.

§ *Journ. Bot.*, xli. (1903) pp. 257-60 (1 pl.).

|| Overs. k. Danske Videnskabs. Selskabs. Forh., 1902, No. 6, pp. 249-56. See also *Bot. Centralbl.*, xciii. (1903) p. 258.

**Production of Glycogen in Fungi.\***—In fungi as in vascular plants the production of reserve carbohydrates is connected with the supply of sugar or analogous substances. Emile Laurent has proved an abundant formation of glycogen in *Mucor racemosus*, *Sclerotinia Liberlandiana*, *Botrytis cinerea*, and *Saccharomyces Cerevisie*, grown in a very diluted organic solution to which was added 1 part in 1000 of oxalic acid and 1 part in 2000 of hydrochloric acid. The author suggests the interpretation that the plant absorbs the carbohydrate nutriment more quickly than it assimilates it, hence the presence of the reserve. In a different medium, where growth of the filament was more rapid, the production of glycogen was greatly diminished.

**Production of Acids by Fungi.†**—Berthold Heinze reviews the work that has been done in reference to acid formation during the process of fermentation, and gives results of cultures carried on by himself with a view to testing the results that have been arrived at by others. He grew *Phoma Betæ*, *Aspergillus niger*, *Penicillium glaucum*, and *Mucor stolonifer* in a culture solution with ammonium sulphate added to supply nitrogen. Acids were produced in every case; acetic acid and oxalic acid more particularly by *Aspergillus niger*. The writer draws various deductions from the facts observed by him. He proposes to carry the research further.

**Bacteriophagous Acrasieæ.‡**—Paul Vuillemin cultivated *Dictyostelium mucoroides* in tubes, and found constantly present a fluorescent bacterium which he succeeded in isolating. A pure culture of *Dictyostelium* spores did not grow until the bacterium was re-introduced. Microscopic examination showed the bacillus engulfed and absorbed by the amœbæ. The pyocyanic bacterium was introduced into one of the cultures with negative results. This bacterium has alkaline properties, so it would seem that it is not alkalinity of nutriment that is secured for the *Acrasie* by the bacterium, but that it is a necessary food.

**Acrasieæ.§**—Edgar W. Olive has issued his monograph of the members of the group. He gives an introductory historical account of them and describes fully their life-history, comparing them with allied organisms. The amœbæ divide after issuing from the spore by indirect division, though details of this have not all been worked out. After some time a secondary division takes place, and it does not seem to be accompanied by nuclear changes. Special study was made of their nutrition, and though they undoubtedly inclose and absorb bacteria, yet the writer concludes that nourishment is mainly absorbed in liquid form and that the ingestion and digestion of solid food-particles is exceptional. The aggregation of the myxamœbæ and the formation of the fructifying stage are described, and the results of experiments on the irritability of the pseudoplasmodium are given. Finally the author gives a review of their systematic relations, and a classification of the genera and species.

\* Comptes Rendus, cxxxvii. (1903) pp. 451-3.

† Ann. Mycol., i. (1903) pp. 344-53.

‡ Comptes Rendus, cxxxvii. (1903) pp. 387-89.

§ Proc. Eost. Soc. Nat. Hist., xxx. (1902) pp. 451-513 (4 pls.).

**Rinodina.\***—In examining the lichens of the Regnell expedition Gust. O. A. N. Malme reviews the history of the genus *Rinodina*, and notes the species already recorded from Brazil. He considers that the genus is well founded and approaches nearer to *Physcia* from the nature of the spores than to *Lecanora*, in which genus the species have been included by various systematists. He divides the genus into a number of sections and subsections. He describes in detail 16 species and gives a list of those he has determined.

**Brazilian Lichens.†**—A. Zahlbrückner describes the lichens collected in Rio de Janeiro and the neighbourhood by various collectors. He gives full diagnoses and notes of species that have been imperfectly described, and of the species determined as new, of which there are a large number. He employs chemical reagents, and under each species gives the characteristic reactions.

**Morphology of Lichens.‡**—Birger Nilson is inclined to regard the fungus of lichens as parasitic on the alga. In certain conditions of humidity the alga increases more rapidly than the fungus, and hence the development on the surface of the thallus of soredia and isidia. The form of the thallus is also largely influenced by the condition of the alga, which again depends on climatic conditions, thus accounting for the variations in form of the lichen plants. He discusses also the systematic arrangement of the group.

**Lichen Flora.§**—After a pause of five years, the second part of the Lichens in the *Pflanzenfamilien* has just been issued under the editorship of A. Zahlbrückner. He divides Lichens into three classes: Ascolichenes, Hymenolichenes, and Gasterolichenes. The Ascolichenes are again divided into two groups, Pyrenocarpeæ and Gymnocarpeæ. The author in this part passes under review all the families and genera of the first group. The families are distinguished by the nature of the symbiotic alga, one series possessing *Pleurococcus* or *Palmella* gonidia, a second being associated with *Chroolepus*. The genera are classified according to the form of the fruit, paraphyses, spores, &c.

Of the Gymnocarpeæ he makes three divisions: Coniocarpineæ, Graphidineæ, and Cyclocarpineæ, distinguished entirely by the form of the fruit. He finishes the discussion of the Coniocarpineæ and advances a good way with the Graphidineæ.

**MASSE, G.—Distribution of Calostoma.**

[A North American specimen is recorded from Japan, with a note on its distribution.] *Nature*, LXVIII. (1903) p. 296.

**NAVAS, R. P. LONGINOS—Lecanora subfusca in Spain.**

[With an account of the varieties of this lichen.] *Bolet. Soc. Espan. Hist. Nat.*, III. (1903) pp. 285-90 (fig. in text).

**NOELLI, A.—Revision of Steganosporium.**

[The genus includes six species and one variety.] *Malpighia*, IX. (1903) pp. 412-18 (6 figs.).

\* Bihang. k. Vet.-Akad.-Handl., iii. (1903) No. 1, 53 pp. (2 figs.).

† S.B. k. Akad. Wiss., cxi. (1902) pp. 357-432 (2 pls.).

‡ Botaniske Notiser, 1903, Heft I, 33 pp. See also Centralbl. Bakt., x. (1903) pp. 602-3.

§ Die Natürlichen Pflanzenfamilien, Engler und Prantl, Lief. 217 (1903) pp. 49-96 (figs.).

PAVILLARD, J., & J. LAGARDE—*Myxomycetes* from the neighbourhood of Montpellier.

[A descriptive list of the species collected, with some notes on nomenclature.]  
*Bull. Soc. Mycol. France*, XIX. (1903) pp. 81-105 (1 pl.).

SMITH, WORTHINGTON G.—*Hygrophorus Clarkii* B. and Br.

[Notes on the history of this species, which is probably identical with a more recently recorded species of *H. laetitabundus* Britz.]

*Journ. Bot.*, XLI. (1903) pp. 313-4.

” ” ” *Lentinus Lepideus* Fr.

[A general account of the abnormal forms of this fungus. A *Clavaria*-like form was found recently in Scotland.]

*Journ. Bot.*, XLI. (1903) pp. 321-3 (figs.).

” ” ” *Agaricus versicolor* Wittr.

[The writer clears up the confusion that has arisen in describing and re-describing this plant. It is really a small form of *A. melleus*.]

*Journ. Bot.*, XLI. (1903) pp. 341-3.

SPEGGAZINI, C.—*Argentine Fungi*.

*Anal. Mus. Nacion. Buenos Aires*, VIII. (1902) pp. 49-89. See also  
*Centralbl. Bakit.*, X. (1903) p. 71.

STRAWSON, G. F.—*Fungicides*.

[A manual of description and instruction as to the preparation and application of various sprays.]

*Standard Fungicides and Insecticides in Agriculture*. By  
G. F. Strawson. Part 1, 76 pp.

ZÄHLERÜCKNER, A.—*New Lichens*.

[A series of new European forms. There is one new genus, *Pseudoheppia*.]  
*Ann. Mycol.*, I. (1903) pp. 354-61.

## ‡ Schizophyta.

### Schizophyceæ.

**Cyanophyceæ.\***—F. Brand gives some of the results of his investigations on the morphology and physiology of this group. He deals with his subject under several headings. The first is “Resting-cells (spores)” in which he compares his own results with those of other authors and gives a list of the orders in which these bodies occur. “Heterocysts” are then dealt with under development of the heterocysts, pores and polar thickening of membrane, contents of heterocysts, and physiological and biological meaning of heterocysts. “Gonidia and microgonidia” is followed by a section headed “Spaltkörper.” This term is used to denote the ring-like bodies which are seen separating two previously contiguous cells, as in *Calothrix confervicola*. “Active movement of the hormogonia,” is the title of the last section, which gives in detail the results of various observations made by the author, together with remarks on the work of other writers. A bibliography follows.

### ‡Schizomycetes.

*Thiophysa volutans*.†—G. Hinze has given this name to a colourless sulphur bacterium which was found among the sand near to sulphur wells in the neighbourhood of Naples. The organism is globular,

\* *Beih. Bot. Centralbl.*, xv. (1903) pp. 31-64 (1 pl.).

† *Ber. Deutsch. Bot. Ges.*, xxi. (1903) pp. 309-16 (1 pl.).

7-18  $\mu$  in circumference, and contains sulphur globules. It is without cilia, but possesses the power of movement. Hinze could not discover any nuclei, but he found small bodies in the cell which he considers to be chromatin-grains. Division takes place by elongation of the globular cell with a subsequent median constriction and the rounding off of each half into daughter-cells, which immediately repeat the process.

**Achromatium oxaligerum.\***—Otto Zacharias found this organism in great abundance in damp moor soil. The original discoverer, Schewiakoff, was unable to detect any motile organ. Zacharias has found a single cilium at one end equal in length to the bacterium-like body. The older individuals lose the power of motion.

**Salmon Disease.†**—J. Hume Patterson claims to have demonstrated that salmon disease is not caused by the fungus *Saprolegnia ferax*, but by a bacillus, the *B. salmonis pestis*. Working with pure cultures, he found that fish kept in direct contact with *Saprolegnia* remained unaffected. On the other hand, fish inoculated with the bacillus all died, as they did also when *Saprolegnia* was combined with the bacillus in the inoculation. In the latter case, however, there was growth of the fungus as well. Fish inoculated with *Saprolegnia* and other micro-organisms remained healthy.

Some of the chief characteristics of the bacillus are these:—A short thick bacillus with rounded ends and actively motile. Non-spore-bearing. Grows profusely at room temperature and at 0° C., but not at 37° C. Liquefies gelatin, coagulates milk, and grows well in sea-water. Strict aerobe. Does not stain by Gram's method. Pathogenic to fish. Non-pathogenic to frogs, mice and guinea-pigs.

**Chemical Products of Diarrhœa-producing Bacteria.‡**—Sydney Martin has studied the action of the products of *B. dysentericæ* (Krüse), representing the bacteria of infective diarrhœas; and also that of the products of *Proteus vulgaris*, representing the bacteria of putrefactive diarrhœas.

*B. dysentericæ*. From experiments with filtered cultures he finds that a soluble poisonous body is formed by the bacillus, the effect of which is, in the rabbit, to produce lowering of temperature, loss of weight and diarrhœa. The alcoholic extract of the filtrate being practically inactive, the author assumes that the poisonous effect of a filtered culture is not due to a non-proteid body. Injections of the dried and powdered bodies of dead bacilli caused marked symptoms in the rabbit, followed by rapid death. The most potent poison of the bacillus is therefore probably contained in them.

*Proteus vulgaris*. Filtered cultures caused transient disturbance of temperature and diarrhœa.

The experiments were, at the time of the publication of the paper, being continued.

\* Biol. Centralbl., xxiii. (1903) pp. 512-3.

† Rep. Brit. Assoc., 1902, pp. 647-9.

‡ Rep. Med. Off. Local Gov. Board, 1901-2, pp. 395-403.

**Luminous Bacteria.**\*—J. E. Barnard and Allan Macfadyen have studied these organisms, chiefly marine. They advocate the addition of 3 p.c. NaCl to the culture media. This favours luminosity, which appears to be essentially a vital phenomenon. Dead cells are non-luminous. A supply of free oxygen is necessary for the luminosity, though not for the life of the cell. Exposure to low temperature—that of liquid air—did not destroy the luminosity of the organism.

**The Bactericidal Action of some Ultra-Violet Radiations as produced by the Continuous-Current Arc.**†—J. E. Barnard and H. de R. Morgan experimented to determine the effect on the vitality of certain bacteria of exposure to the arc spectra of carbon and of various metals. The spectrum was projected on to an agar film, contained in an ordinary Petri dish, over the surface of which had been spread with a sterilised brush an active culture of the organism. The plates were exposed to the light directly after inoculation, and were then incubated for 24 hours at 37° C. It was found that the bactericidal action was entirely confined to the ultra-violet region. The active radiations lie in that portion of the spectrum between the wave-lengths 3287 and 2265. Neither the extreme ultra-violet rays nor those nearest to the visible violet appeared to be active.

Experiments were also made with hanging-drop preparations, when with the distance of the arc from the drop at 10 cm., and the current used 11 ampères, the organisms were killed in from 15–30 minutes, according to the metal employed.

**Agglutination by Blood of Emulsions of Microbes, with special reference to Specificity.**‡—E. Klein found that the blood of different typhoid cases varied in agglutinating power. He failed to obtain agglutination by typhoid blood of any of the varieties of *B. coli* isolated by him from typhoid stools, or of *B. coli communis* obtained from various other sources. He found that typhoid blood had an agglutinating reaction on the Gärtner bacillus and on the Danysz rat bacillus, though this was less than the reaction of the same blood on *B. typhosus*. Experimenting with the blood of “Danysz-immunised” guinea-pigs, the author found that it had the power of agglutinating *B. typhosus*, as well as Gärtner and Danysz. A like result was obtained with the blood of “Gärtner-immunised” guinea-pigs.

**La Garotilha.**—E. Marchoux and A. Salimbeni,§—following Chapot-Prévost, and Gomez and Terni—have demonstrated that the disease of cattle known in Brazil as *la Garotilha* is anthrax, and they believe that the vultures so numerous in that country are responsible for its spread. They fed one of these birds on an infected guinea-pig, and readily isolated the *B. anthracis* from the excreta.

**Researches on the Fermentation of Milk.**—H. Tissier and E. Gasching || kept samples of milk under observation for 8 to 10 months.

\* Rep. Brit. Assoc., 1902, p. 801.

† Proc. Roy. Soc., lxxii. (1903) pp. 126–8.

‡ Rep. Med. Off. Local Gov. Board, 1901–2, pp. 440–54.

§ Ann. Inst. Pasteur, xvii. (1903) pp. 564–8.

|| *Com. cit.*, pp. 540–63.



They regard as constant organisms: *Enterococcus* (Escherich), *B. coli*, *B. acidi paralactici*, *B. subtilis*, *B. mesentericus*, *B. faecalis alcaligenes*, *B. lactopropylbutyricus*, and *Oidium lactis*.

Lactic acid fermentation was found to be caused by *Enterococcus*, *B. coli* and *B. acidi paralactici*; *Enterococcus* produced also valerianic and acetic acids. Butyric acid fermentation was found to be caused by *B. lactopropylbutyricus* alone, which produced also propionic acid.



## MICROSCOPY.

## A. Instruments, Accessories, &amp;c.\*

## (1) Stands.

**Leitz' Mineralogical Stand, No. I.†**—This stand is numbered 37 in the makers' series, and is shown in fig. 163. In its general dimensions it corresponds to the Leitz stand known as No. 1 A. The coarse adjustment is by rack-and-pinion, and the fine by a micrometer screw graduated into fifty divisions, a graduation signifying a movement of 0.01 mm. The condenser, iris diaphragm and polariser are raised and lowered by rack-and-pinion. Observation of the axial images is conveniently performed by means of a three-limbed condenser, which can, by means of lateral push-movement of the stop-carrier under the stage, be drawn out and replaced. The objective is centred on the rotation-centre of the rotatory object-stage, by means of a centring nose-piece. The stage itself is graduated into 360° with a vernier; it also bears graduations for orientating. The Nicol acting as a polariser can, after removal of the iris diaphragm from underneath, be itself drawn out. The 0°, 90°, 180°, 270° of this Nicol are marked. The analyser is set in a metal holder in a fixed position over the ocular, and the rim of the indicator is graduated into 360°. On the front of the tube is a flap which can be opened and closed, and through which the inner tube is accessible; in the inner tube there is a slit for the reception of a Bertrand lens. The function of this lens is to assist the ocular in magnifying the interference figures formed in the converging polarised light; lens and ocular are raised and lowered together, as desired, by means of rack-and-pinion. In the analyser there is a slit (45° to the zero) for films of selenite and Iceland spar. In many investigations it is recommended that, instead of the above, an analyser should be used inserted laterally into the tube. There is a revolver for three objectives.

**Leitz' Mineralogical Stand, No. II.‡**—The series-number of this instrument is 39 (fig. 164). The tube is carried by a brass foot and pillar, highly lacquered, and the adjustment is by rack-and-pinion. The rotatory stage is graduated on its circumference to 360°, and the reading is by a pointer. The polariser is set in a spring collar, whose zero and quadrant points are marked. The collar with the polariser is inserted in a holder which, by means of a lateral screw, can be raised and lowered or drawn aside. An illuminating lens is placed over the polariser in the stage, and by means of a lever can be turned out of the path of the

\* This subdivision contains (1) Stands; (2) Eye-pieces and Objectives; (3) Illuminating and other Apparatus; (4) Photomicrography; (5) Microscopical Optics and Manipulation; (6) Miscellaneous.

† Catalogue, No. 40, Nov. 1902, pp. 55-7.

‡ Tom. cit., pp. 58-9.

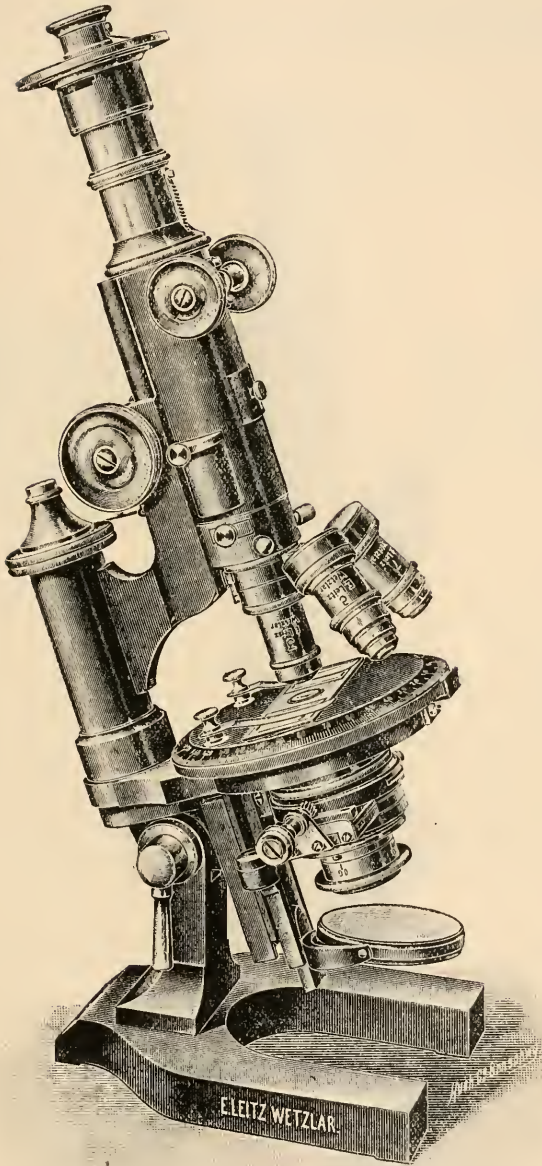

FIG. 163.

beam of rays when parallel polarised light is substituted for converging. The analyser is inserted in the optical axis in a broad slit in the tube over the objective, and is pushed in and out by a knob. Under the

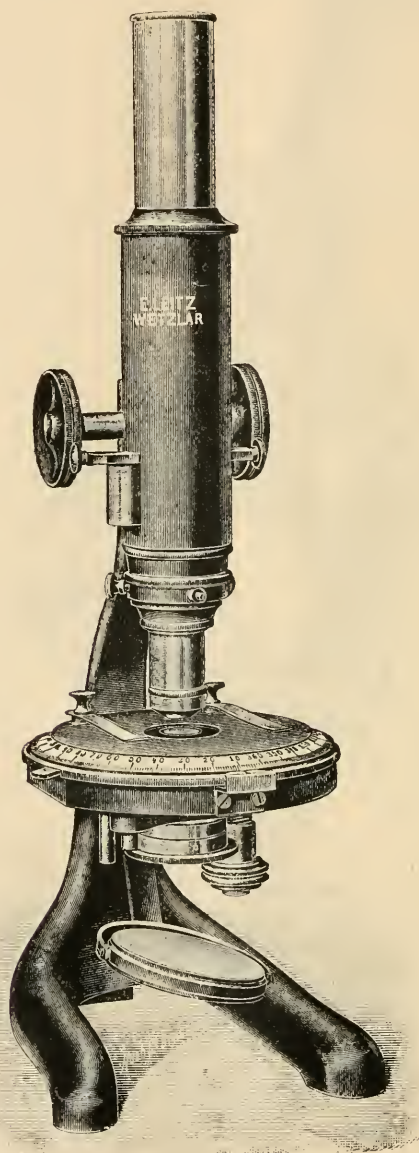

FIG. 161.

analyser is a slit for the selenite and quartz plates. The objective is centred on the rotation centre of the rotatory object-stage, by means of two centring screws acting on a centring nose-piece.

**Leitz' Handloups.\***—The catalogue numbers of these are 69 and 70. The loupes (figs. 165, 166) consist of two achromatic double lenses, producing a field very large, flat and free from tint. The magnifying powers are five and eight-fold, the corresponding diameters of the lenses being 30 and 23 mm., while the field of view measures 35 and 20 mm. respectively.

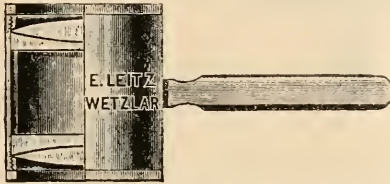

FIG. 165.

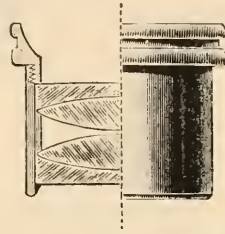

FIG. 166.

**Very Powerful Micrometric Microscope.†**—P. Boley finds that the “double Microscope,” which he designed ‡ for observing the slightest displacement of the mercurial meniscus of the capillary electrometer, can be also used for ordinary purposes as a micrometric Microscope. In principle the Microscope is one in which the ordinary ocular is replaced by a true compound Microscope of large objective. It is formed of a tube double the usual length, with the principal objective at the anterior end, the objective of the ocular Microscope in the centre, and the actual ocular at the posterior end. The ocular-holder is tube-shaped and slides inside the main tube. The whole is fitted on a stand having three rectangular movements for controlling the field. The image obtained is erect, and the original magnification is increased from four to six-fold.

**Watson's “Argus” Attachable Mechanical Stage.**—This is a simplified form of mechanical stage, which can be readily attached by a single thumb-screw (fig. 167). The moving plates are not fitted in dovetailed grooves in the ordinary manner, but slide on guides, and are held in position and actuated by a frictional wheel made of brass and covered with indiarubber. This wheel is revolved by means of a milled head, which can be set in any position from the horizontal to the vertical, the movement taking place at right angles to its own direction.

The horizontal and vertical positions are indicated by spring catches, but between the two points a range of diagonal traverse is given when

\* Catalogue, No. 40, Nov. 1902, p. 64.

† Trav. Sci. Univ. Rennes, i. (1902) pp. 340-2.

‡ Tom. cit., p. 277.

the milled head is operated. Being independent of racks and screws, no back-lash can occur. The range of motion is about  $1\frac{1}{2}$  in.

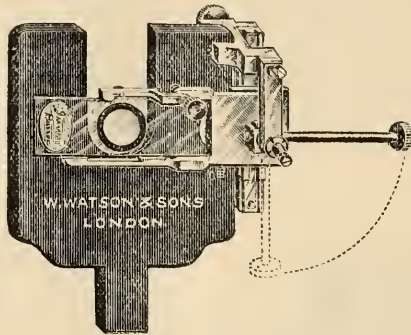

FIG. 167.

**A Lens Pseudoscope.\***—The Wheatstone pseudoscope is composed of two totally reflecting prisms arranged with their edges perpendicular to the plane of vision. H. Bowden has arranged a pseudoscope in which he employs two pairs of identical convex lenses. He contrives a bar-frame like a capital H, the four lenses being set in sliding mounts on the outer lines. A handle in the middle of the cross-bar and perpendicular to the frame makes a good holder. One of the observer's eyes looks at an object through one pair of the lenses, and his other eye views it through the other pair. The planes of the lenses are so disposed that their foci coincide, and thus superimposed images are presented to the observer. It was found that the illusions produced were very complete, and had a superiority over the Wheatstone pseudoscope; but the images presented by it are inverted as well as transposed from right to left.

(2) Eye-pieces and Objectives.

**Graphic Representation of the Correction Distance of an Objective.†**—H. Schmidt shows how, in the absence of the appropriate instrument, an idea of the astigmatism of a lens may be obtained. It is necessary to calculate, from the formulæ, the horizontal and vertical foci of oblique rays, and then to plot them to scale on paper. A curve should then be drawn free-hand through each set of foci. If these curves coincide the astigmatism will be nil; it will also vanish at points where they intersect: the amount of divergence on any ray will indicate the astigmatic difference for that ray. It may sometimes be desirable to plot on a magnified scale when the curves show close approximation.

**The Injurious Effect of Cement upon Objectives.‡**—G. Eberhard found that the zonal errors of certain telescope objectives markedly

\* *Trav. Sci. Univ. Rennes*, i. (1902) pp. 157-163 (2 figs.).

† *Central-Zeit. f. Opt. und Mech.*, xxiv. (1903) pp. 73-5 (3 figs.).

‡ *Zeit. f. Instr.*, xxiii. (1903) pp. 274-7 (2 figs.).

varied with the temperature. He attributes this to changes in the Canada balsam cement, which seems to possess a hitherto unsuspected variability dependent perhaps on age as well as on temperature. Among other experiments he tested a certain camera objective before and after ten hours' heating at  $60^{\circ}$  C.; all the zonal errors were altered, one, e.g. rising from  $-0.05$  to  $+0.56$ . In very important work, he concludes it would be best to use objectives free from cement.

EVERETT, J. D.—On Skew Refraction through a Lens; and on the Hollow Pencil given by an Annulus of a very obliquely placed Lens.

*Proc. Roy. Soc.*, LXXI. (1903) pp. 509–522 (2 plates).

SCHROEDER, H.—Ueber die Geschichte der Technik der Mikroskope.

[Mainly an historical account of the evolution of modern lenses, interspersed with interesting anecdotes.]

*Central. Zeit. f. Opt. u. Mech.*, XXII. (1901) Nos. 19, 20, 21, 22.

### (3) Illuminating and other Apparatus.

**Tubeuf's Drawing Apparatus.\***—This apparatus (fig. 168) is intended for drawing objects from nature. By means of a prism an object is so reflected into the eye that its vertical projection on the drawing plane appears erect, a very desirable condition in nature-drawing. On the prism plane turned towards the object, smoked glasses of various

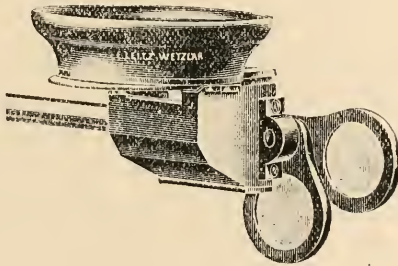

FIG. 168.

thicknesses can be applied for reducing the brightness of the object. On the prism plane towards the eye there is a small revolving disc, with small apertures for regulating the pupil opening. The prism can be set on a stand at various heights and widths.

**Fuess' Hemispherical Gypsum and Metal Reflectors.†**—These reflectors, numbered 8 in the maker's catalogue, are intended to be placed on the Microscope stage over an opaque object of very small dimensions. The arrangement is shown in fig. 169. The light coming from the mirror reaches the white spherical interior of the gypsum, and is thus completely reflected in all directions; the object being thereby completely and uniformly illuminated without shadows. An opening

\* Leitz' Catalogue, No. 40, Nov. 1902, p. 74; *Centralb. f. Bakt.*, 1899, pp. 765–6.

† Fuess, *Special-Liste*, No. 74, pp. 4 and 5.

in the top facilitates adjustment and transmission of the image. The reflector is made in two sizes, whose diameters are 30 mm. and 50 mm.

Exactly similar reflectors are also made out of metal.

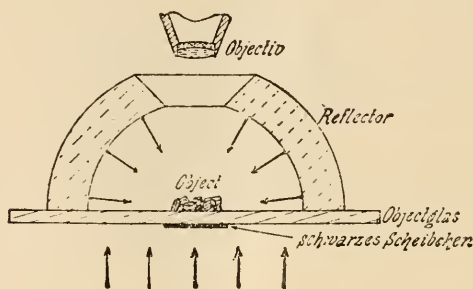

FIG. 169.

The same firm also supply round object-slides of white mirror-glass, with a metal plate cemented on to the centre; the effect is to give a completely black underground.

#### (4) Photomicrography.

**Photography by Natural Lenses.\***—W. F. Watson has used the crystalline lens from a bullock's eye for photography. A lens-holder was constructed out of a small cardboard pill-box, with a perforated ledge inside for the reception of the eye. The lid and floor of the box are pierced with circular holes smaller than the lens, and it was found necessary to keep its surface moistened with a brush. The lens must be so placed that the flatter surface is underneath and the rounder one uppermost; and, when once arranged, it must, if possible, not be touched, owing to its delicate nature. The object to be photographed was illuminated with natural light in the ordinary way. It was found an improvement to enclose the crystalline lens, fresh from the animal's eye, between two large watch-glasses of suitable curvature and true shape, their inner surfaces being moistened. These lenses were then completely covered with blackened gummed paper, with the exception of the small circular openings in the middle of the convex surfaces. The lens so prepared could then be applied to the camera.

The author has also used the eye-lens of a fly for photographic purposes, and has reproduced the well-known multiple images. He gives specimens of his success.

MARKTANNER-TURNERETSCHER, G.—Wichtigere Fortschritte auf dem Gebiete der Mikrophotographie und des projektionswesens.

[Gives a comprehensive résumé of international progress in these departments of science.]

S.A. Jahrb. f. Photographie und Reproduktionstechnik f., Halle, 1903, 10 pp.

\* Scientific American, quoted in Central-Zeit. f. Opt. und Mech., xxiv. (1903) pp. 144-6 (7 figs.).



## (5) Microscopical Optics and Manipulation.

**Drude's Theory of Optics.**\*—This important work has been translated from the German into English by C. R. Mann and R. A. Millikan. The preface to the English translation has been written by Prof. Michelson, who states that there is no other book in English which embodies the important advances in both theory and experiment made during the last decade. It excels in presenting a complete development of the electromagnetic theory of light in all its bearings, and a comprehensive discussion of the relations between the laws of radiation and the principles of thermodynamics.

The book consists of three parts, respectively devoted to: (i) Geometrical Optics, (ii) Physical Optics, and (iii) Radiation.

Part i. is on the usual lines, and follows closely Czapski's treatment in Winkelmann's *Handbuch der Physik*.

Part ii. is subdivided into two parts: general properties of light, and optical properties of bodies. This part includes, as an important advance upon most previous textbooks, Sommerfeld's rigorous solution of the simplest case of diffraction, Cornu's geometric representation of Fresnel's integrals, and, on the experimental side, Michelson's echelon spectroscope. It also extends the hypothesis as to the nature of light. The mechanical theories are merely mentioned, but the electromagnetic theory, which the author considers to present the simplest and most consistent treatment of optical relations, he has discussed at length.

Part iii. is concerned with the relation of optics to thermodynamics, and (in the third chapter) to the kinetic theory of gases.

**Numerical Aperture and Rapidity.**†—W. A. E. Conrady in a paper on this subject remarks, that whereas Microscope lenses are classified by their N.A., photographic lenses are by their *f*-values, i.e. *f*/8, *f*/16, &c. Formulæ are given: first, to express the N.A. of a Microscope-lens in terms of photographic *f*-value; secondly, for converting photographic *f*-values into N.A.

$$\text{I.} \quad f\text{-value} = \frac{m}{2 \text{ N.A.}}$$

$$\text{II.} \quad \text{N.A.} = \frac{m}{2(m+1) \times f\text{-value}}$$

N.A. is numerical aperture, and *m* magnifying power.

**Specific Double Refraction of Plant Tissues.**‡—B. Remec, after many experiments, concludes: (1) That lignin has no influence on the specific double refraction of plant tissue; (2) that even in cell-walls of similar thickness and similar chemical composition, the degree of double refraction may vary according to peculiarity of organisation; (3) that if pores exist in the cell-wall, the greatest optical axis of elasticity of Fresnel's ellipsoid lies in the direction of the pores; (4) the membranes of superposed tissues generally produce elliptic polarisation, the main axis being sometimes parallel, sometimes perpendicular to the anatomical

\* Longmans, Green & Co., London, 1902, 546 pp. (110 figs.).

† Knowledge, xxvi. No. 216 (1903) p. 236.

‡ S.B. Akad. Wiss. Wien., pp. 364-87 (3 figs.).

cell-axis; (5) that it is possible in many cases of equal chemical composition and equal morphological formation to distinguish histological elements from one another in polarised light.

**Visual Purple.\***—J. Von Kries considers that visual purple is a substance which supplies the retinal basis for vision at low luminosities, and the accumulation of this substance is accountable for the great increase in sensitiveness of the dark-adapted eye—a thousand-fold increase according to some computations.

**Some Experiments with Actinic Light.†**—J. W. Kime, with the object of furthering the application of coloured light in therapeutic treatment, has conducted some experiments for the purpose of localising those bands in the solar spectrum which are rich or poor in actinic rays. Strips of glass, corresponding in colour to the various tints of the solar spectrum, were placed in a frame, bound to a sensitised plate, and exposed almost instantaneously to very weak diffused daylight, which entered the dark room without passing through glass. The result is shown in fig. 1, plate VIII., which is a negative plate. The open space and the plain glass strip, which were also provided, when compared with the blue glass present very little difference, the plain glass being a shade darker, showing that less actinic light passed through it than through the other two. It was found that no light whatever reached the plate through the red, and no trace is apparent in the orange; the yellow transmits an appreciable amount; and the green just enough to be seen. From this point we jump from almost zero in the green to 100 p.c. in the blue. Hence wave-length has nothing to do with determining the chemical activity of the light. In the indigo there is a slight diminution from the blue, but there is still fully as much as traversed the plain glass. In the violet we drop back to about the same percentage as in the yellow. It is apparent from the photographs that colour, independently of wave-length, influences the chemical action of light. Fig. 2, plate VIII., which is a positive, is in every sense confirmatory of the conclusions drawn from fig. 1, but was produced in a directly opposite manner. The same strips of glass as before were again used, but were placed over ordinary photographic printing paper, Aristo, and were exposed to the sun until the open space was fully printed. No other glass intervened between the sensitised paper and the sun except the strips referred to. Experiments were also made to test the penetrability of actinic light through the tissues of the human body.

KEÜSS, H. A.—Die Durchlässigkeit einer Anzahl Jenaer optischer Gläser für ultraviolette Strahlen. *Zeit. f. Instrumentenkunde*, XXIII. (1903) pp. 197–207, 4 figs (July); and pp. 229–239, 3 figs. (August).

SIEDENTOPF, H., & R. ZSIGMONDY—Über Sichtbarmachung und Grösserbestimmung ultramikroskopischer Teilchen, mit besonderer Anwendung auf Goldrubingläser.

[The substance of this pamphlet was given to the Society at the Meeting on June 17, 1903, and is reported in the Proceedings for that date.]

*S.A. Physik. Vierte Folge*. X. (1903) 39 pp.

A copious French abstract of the preceding appears in the *Bibliothèque Universelle (Arch. Sci. Phys. et Nat.)*, XVI., Geneva, 1903, pp. 130–8.

\* Abhandl. z. Physiol. d. Gesichtsempfindungen, 1897, pp. vi. and 198; 1902 p. 197. Leipzig.

† Scientific American, quoted in *English Mechanic*, lxxviii. (1903) pp. 478–9 (3 figs.).

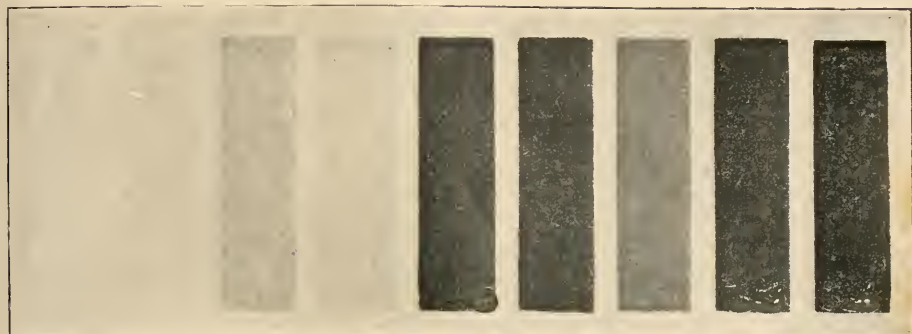

FIG. 1.

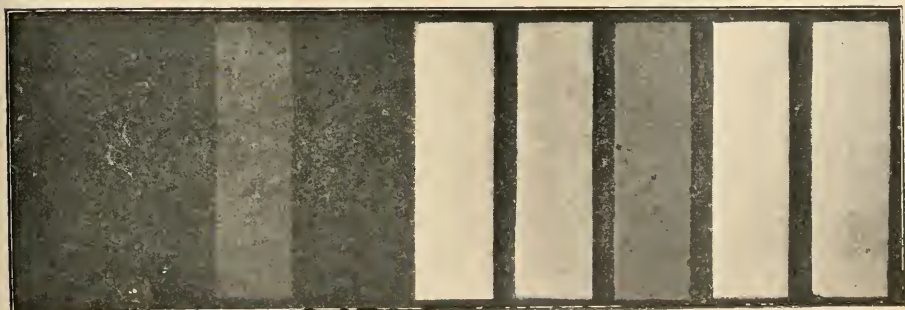

FIG. 2.

Experiments with Actinic Light.



### B. Technique.\*

#### (1) Collecting Objects, including Culture Processes.

**Method of Preparing Sugar-free Bouillon.**†—F. E. Montgomery has found that if meat infusion be sterilised previous to the inoculation with the colon bacillus, an odorless sugar-free broth is obtained. The method is as follows: To a portion of the fat-free beef, ground fine, add double its weight of cold water, and bring slowly to a temperature of 50° over water bath. Keep at this temperature for three hours, then strain through muslin. Steam sterilise the infusion for three-quarters of an hour. Allow to stand overnight in an ice-box, and then inoculate with *B. coli communis*. Incubate at 37·5° for 18 to 24 hours, then boil and filter. Next add  $\frac{1}{2}$  p.c. NaCl and  $\frac{1}{4}$  p.c. peptone, and boil for three-quarters of an hour. Neutralise with NaHO, filter and sterilise.

**Cultivation Medium for Algæ.**‡—G. T. Moore finds that for general purposes a modification of Beijerinck's medium is very satisfactory. This consists of ammonium nitrate, 0·5 gm.; potassium phosphate, 0·2 gm.; magnesium sulphate, 0·2 gm.; calcium chloride, 0·1 gm.; distilled water, 1000 c.c.m.; iron sulphate, a trace.

For blue-green Algæ, the amount of ammonium nitrate should be doubled, and the addition of from 1–2 p.c. glucose is often of benefit. This solution may be used with silica jelly, though  $\frac{1}{2}$ –1 p.c. of agar hardens it sufficiently for general purposes.

**Demonstration of Tubercle Bacilli in Sputum.**§—A. Nebel advises that the sputum be well shaken up with 8–10 times its volume of lime water. This renders it apparently homogeneous, and it is then centrifuged for 2 minutes. The supernatant fluid is passed through a Berksfeld filter; and the deposit remaining on the filter removed, mixed with a drop of water, and examined in the usual way.

The author found that after centrifuging, the sediment did not contain more bacilli than fell to its lot on account of its weight and volume.

**New Method of Isolating *B. icteroides*.**||—J. Bandi makes use of the agglutinating power of anti-amaryllic serum as a means of separating *B. icteroides* (Sanarelli) from other organisms. He first determines accurately the specific agglutinating doses of the serum, both for the bacillus in question and for the organisms found most frequently in symbiosis with it. Serum is then added, in the former proportion, to a (7 p.c.) gelatin nutrient medium contained in tubes drawn out to a closed funnel-shaped point at the lower end. The tubes are then superficially inoculated with the material to be examined and incubated

\* This subdivision contains (1) Collecting Objects, including Culture Processes; (2) Preparing Objects; (3) Cutting, including Imbedding and Microtomes; (4) Staining and Injecting; (5) Mounting, including slides, preservative fluids, &c.; (6) Miscellaneous.

† Journ. App. Micr., vi. (1903) p. 2409.

‡ Tom. cit., pp. 2309–14.

§ Arch. f. Hyg., xlvii. (1903) p. 57. See Centralbl. Bakt. Ref., xxxiii. (1903) pp. 665–6.

|| Centralbl. Bakt. Orig., 1<sup>o</sup> Abt., xxxiv. (1903) pp. 463–79.

at 37° C. After 10–12 hours the *B. icteroides* will be seen to have settled in the lower part of the tube, in flocculent agglutinated masses. The culture is then cooled down and the gelatin allowed to set. The pointed end of the tube is then broken off, and some of the flocculi removed with a platinum needle, isolation being effected by this means. If the culture is mixed with organisms which naturally fall in masses to the bottom of the culture medium, e.g. streptococci and the proteus varieties, then, the pointed end of the tube having been broken off, its contents are poured in a very thin layer into a Petri dish, and the masses picked out by means of their characteristic appearance under the microscope.

**Tubes for the Preparation of Aërobic and Anaërobic Cultures under the Influence of Coloured Rays.\***—E. Bartarelli. The apparatus (fig. 170) is made of two large test-tubes. One, measuring 25 cm. in length and 3.5 cm. in diameter, has a small cylindrical tube blown in its lower end. The other, about 1 cm. shorter than the first and 2.8 cm. in diameter, has near its lower end three indentations. The lesser is placed inside the larger and their edges fused together. The space between the two tubes is now filled with a coloured solution through the hole in the outer, which is then corked. A monochromatic chamber is then produced in the inner tube. In this chamber the culture tube is placed. If anaërobic conditions are required the inner tube may be used à la Buchner.



FIG. 170.

**Rapid Method of Hardening and Imbedding Tissues.†** B. M. Bolton and D. L. Harris found that tissues can be readily hardened and imbedded for cutting into sections in a hot solution of agar and formalin. Nine parts of a 5 p.c. aqueous solution of agar are mixed with 1 part of formalin. The agar is boiled, for several hours, and after the addition of the formalin allowed to clear by sedimentation. The bits of tissue are placed in a wide test tube containing some previously melted mixture. This is kept at 60°–70° C. for an hour or longer, and the tissue then blocked, after which it is immersed in strong or absolute alcohol for an hour or so, when it is ready to be cut. The whole process does not exceed 3 to 4 hours,

when the pieces are not more than 1 cm. in diameter.

**Preparation of Diatoms.‡**—F. J. Keeley calls attention to the following method for studying the structure of diatoms. This consists in depositing on the diatoms a thin film of silver, using the solution ordinarily employed for silvering mirrors, which, dropped on the cover glass containing the diatoms, will silver the latter to a considerable extent before any appreciable quantity of the metal is deposited on the

\* Centralbl. Bakt., 2<sup>te</sup> Abt., x. No. 22–3 (1903) pp. 739–40.

† Journ. App. Micr., vi. (1903) p. 2414.

‡ Proc. Amer. Nat. Sci. Philadelphia, lv. (1903) pp. 2–3.

glass. The preparations are mounted in balsam and inspected by transmitted light. This process differs from that by which A. Y. Moore plated diatoms, his being covered with a heavy layer of silver or gold and examined as opaque objects. It is rather a staining process, rendering the silica opaque or nearly so, and thus differs from other methods which fill the cavities in the valves with opaque matter. The results so far have been principally corroborative of previous observations, but many features are rendered not only more obvious but new characteristics brought to light, among which may be mentioned a ring of processes near the margin of the valve of *Coscinodiscus subtilis* which extends towards the interior of the frustule. In *Navicula* and its allies the raphe is well displayed, and in *N. rhomboïdes* the raphe is shown to be single.

**Fixation of the Mammalian Egg in the Uterine Cavity.\*—**

H. Schoenfeld excised the gravid uterus of rabbits at intervals of 6 to 10 days after impregnation. The organ was placed for  $\frac{1}{4}$ – $\frac{1}{2}$  an hour in  $\frac{1}{2}$  p.c. chromic acid, in order to coagulate the blood in the vessels, and then cut up into small pieces. These were placed in some fixative solution, the best results being obtained from Hermann's fluid. Flemming's fluid was next best, while sublimate and Zenker's medium were much less efficacious. The sections fixed in fluids containing osmic acid were stained with safranin and picric acid, safranin and light green, or with Heidenhain's iron hæmatoxylin. The sublimate or Zenker sections were stained with Delafield's hæmatoxylin followed by eosin, or by van Gieson's method of iron hæmatoxylin.

**Improvements of Aubertin's Method for Sticking on Celloidin Sections.†—**

F. Müller describes the following modification of Aubertin's method for making celloidin sections adhere to the slide, which procedure consisted in running a mixture of ether and alcohol over the section. The author first puts a thin film of glycerin-albumen on the slide, and warms it over the flame as long as it vaporises. The section is then floated in 95 p.c. alcohol on to the film, and as much of the alcohol as possible removed with blotting-paper. Henceforward the slide must be kept in the horizontal position. When the section begins to look opaque, a few drops of a mixture of equal parts of alcohol and ether are pipetted over. The slide is then left for 5–10 minutes, in which time the ether-alcohol will have evaporated. The slide is then treated for a short while with 70 p.c. alcohol, and afterwards for a longer time with water. The section is then cleared up with carbol-xytol, and may then be stained, or if so desired may be kept for a while. In the latter case it is advisable to immerse the slides for 5–10 minutes in 95 p.c. alcohol, in order to soften the celloidin a little.

**Preparing Sections of Cancellous Bone.‡—**E. O. Little sticks the rough section of bone or tooth on the slide with xytol-balsam. The balsam is then ignited and allowed to burn as long as possible, care

\* Archiv. Biol., xix. (1903) pp. 701–828 (4 pls.).

† Centralbl. Allgm. Pathol. u. pathol. Anat., xiv. (1903) pp. 671–2.

‡ Journ. App. Micr., vi. (1903) p. 2254 (1 fig.).

being taken not to injure the section. The flame is then extinguished, and the section pressed firmly to the slide until the balsam hardens. The free side may then be ground down on a whetstone to any desired thickness.

**Contributions to the Theory of Fixation, with Particular Regard to the Cell-Nucleus and its Albuminous Bodies.\***—W. Berg in an important paper gives the results of his experiments on the individual effects of 24 fixing agents on nucleins and nucleic acids from various sources, and on other bodies, such as clupein—a representation of the protamines—both by itself, as a sulphate, and in combination with nucleic acid. Although sometimes larger quantities were used, a drop of a filtered solution was usually taken—generally in 2 p.c. KOH—of the proteid substance, and mixed with one or more drops of the fixing agent on an ordinary microscopic slide. The effect was then observed as regards (1) the presence or absence of precipitate, (2) its water-solubility, and (3) the forms taken by it. The last the author groups into (*a*) coagula and granular films, (*b*) granules, and (*c*) hollow bodies. He does not claim that the results of his experiments constitute a reliable index to the effects of fixing agents on tissues or on cells, the proteids existing in them not being identical with those of the solutions experimented on. Moreover, the behaviour of the representative of a group of bodies such as the nucleic acids is not constant, but varies with the origin of the substance. For example, acetic acid causes no precipitate with nucleic acid from soft roe of the herring, but with that derived from yeast there is a marked precipitate. Neither are the results with clupein constant with protamines in general. Space will not permit even a résumé of the experimental results. The apparent lack of effect of formalin is however striking. The 33 p.c. alcoholic solution of sublimate is much superior to the 7.5 p.c. aqueous solution. Osmic acid precipitates neither nucleins nor nucleic acids, while alcohol, acetic acid and, above all, chloroform-alcohol-acetic acid have the strongest effect on them.

### (3) Cutting, including Imbedding and Microtomes.

**Manipulation of Sections of Leaf Cuticle.†**—S. M. Bain takes a very narrow strip of the leaf and embeds it in paraffin. The paraffin is trimmed away under a lens until the surface to be cut is reduced to a minimum. The sections, cut off in scrolls, are placed on a small drop of distilled water on the centre of a slide. Here they usually unroll of their own accord; if not, slightly warming may flatten them out. The water on the slide is allowed to evaporate spontaneously, and when dry the slide is warmed until the paraffin just begins to melt. The rest of the procedure is similar to that usually followed.

**Imbedding in Celloidin.\***—C. H. Miller recommends the following method. Into the wide mouthed cork-stoppered bottles are placed solutions of celloidin of graduated strength, each 100 c.cm. containing

\* Arch. Mikr. Anat., lxii. (1903) pp. 367-430.

† Journ. App. Mikr., vi. (1903) pp. 2160-1.

\* Tom. cit., pp. 2253-4.



2, 4, 6, &c., up to 20 grms. by weight of celloidin. The dehydrated tissue is placed successively in the ten bottles for 24 hours. If it is to be cut immediately, the tissue is mounted on a block and hardened in chloroform for 15 to 20 minutes, or in 80 p.c. alcohol for several hours. If it is to be kept for some time, the piece is removed from the 20 p.c. solution with a thick layer of celloidin surrounding it and dropped into chloroform to harden it, after which it is kept in a solution composed of equal parts of 95 p.c. of alcohol and glycerin. When wanted for cutting, the tissue is wiped dry with a clean cloth, a thin layer of celloidin is shaved off, and the piece immersed in 6 p.c. celloidin for several minutes; then mounted on a block and hardened in chloroform. The only inconvenience attached to this method is that it takes 12 days at least, but its many advantages amply compensate for the extra time and trouble.

#### Use of Paraffin Imbedding for Medullary Sheath Staining.\*

G. I. Streeter bases the method he advocates on the supposition that the failure of Weigert's method with paraffin sections is due to the solvent action of xylol on the myelin during the process of imbedding. He stains the tissue in bulk with Weigert's hæmatoxylin, after it has been passed through Müller, or some other chromic solution, and 80 p.c. alcohol. He then brings it into paraffin, melting at 50° C., through 70 p.c. alcohol, absolute alcohol and xylol. Sections are cut and fixed on the slide in the usual way, and brought into water through xylol and alcohol. They are then ready for differentiation, which can be accomplished either by Weigert's solution of potassium ferricyanide and borax, which the author uses diluted ten times, or by the modification of Pal.

**New Method for the Preparation of Horizontal Sections of Thin Laminated Vegetable Flat Tissues.**—P. F. Reinsch † recommends the following method. The substance is first macerated either in water or in some caustic solution, e.g. KOH or H<sub>2</sub>SO<sub>4</sub>. After this it is washed and lifted out on a glass plate. If a caustic solution has been used this is first neutralised with NH<sub>3</sub> or HCl. During the maceration a good deal of gum is probably developed, and by this the substance, as it dries, sticks of itself to the glass plate. If not, then gum or a transparent alcoholic solution of resin must be used, care being taken to avoid flatness and the inclusion of air bubbles. The next step is the separation of horizontal layers as desired, and this is accomplished by carefully damping the flat surface of the object firmly adhering to the glass plate, not its edges, and separating the topmost layer by means of a special microscopic scalpel, which the author makes himself in three shapes out of ordinary medium-sized needles, grinding the half towards the eye end to form a cutting edge, and mounting on holders. He uses this method for such delicate objects as flower petals.

MINOT, C. S.—**History of the Microtome.** Parts I. and II.

*Journ. App. Micr.*, VI. (1903) pp. 2157-60, 3 figs., pp. 2226-8, 1 fig.

\* *Arch. Mikr. Anat.*, lxii. (1903) pp. 734-9.

† *Zeitschr. Wiss. Mikr.*, xx. (1903) pp. 28-33.

## (4) Staining and Injecting.

**Method of Staining Sputum for Bacteriological Examination.**—W. H. Smith\* recommends the following method. Make and fix films in the usual way; stain with anilin-gentian-violet, and warm until steam rises; wash with potassium iodide solution (Gram's), and again warm; decolorise with 95 p.c. alcohol; treat for a few seconds with alcohol and ether (4 : 6), and warm with water; stain for one second with saturated watered solution of eosin; wash surplus away with Löffler's blue, and again warm; decolorise with 95 p.c. alcohol, and thus bring into Canada balsam through absolute alcohol and xylol. Leucocytes, lymphocytes, as well as red blood corpuscles, stain with eosin; whilst the cell nuclei take Löffler's blue. Bacteria positive to Gram stain deep violet or black; whilst those negative to Gram are blue. Bacteria with capsules have the latter tinted with eosin.

**Two Botanical Staining Methods.**†—A. V. Tompa recommends the following :

1. *The Saffron, Prussian-blue and Alcanna Method.*—This depends on the fact that if sections of vegetable tissue are treated with perchloride of iron and ferrocyanide of potassium, in succession, a precipitation of Prussian-blue takes place in the cell-walls. This precipitation occurs only in unthickened cell-walls, and not in vascular bundles, sclerenchyma, cuticular or cork tissue. It is therefore differential as regards the former. If the sections are first treated with tincture of saffron, the woody- and bast-fibres take on a bright yellow colour, and the after use of tincture of alcanna produces a red staining of the cuticular and cork tissue. An important preliminary condition is that the material should have been for some time previously in alcohol, for the removal of the tannic acid, thus avoiding the inky combination of the substance with the perchloride. The author suggests that sections from fresh material should be kept for two days in 96 p.c. alcohol. The steps of the method are these : the sections are placed in tincture of saffron for 48 hours and are then washed in distilled water; they are then placed in a .25 p.c. solution of perchloride of iron for 15–30 seconds, washed for a short time in distilled water, and treated with a .5 p.c. watery solution of ferrocyanide of potassium for 10–20 seconds. The sections are then again washed in water acidified with HCl and in water alone; and lastly are immersed for one second in a hot, watery solution of alcanna. They are then, after a final washing, mounted in glycerin jelly or taken through alcohol and chloroform into Canada balsam.

2. *The Gold Method.*—This depends on the formation of "purple of Cassius," when gold chloride is added to a solution of stannous chloride. Sections from alcohol material are placed in a weak solution of stannous chloride for 24 hours; they are washed in distilled water acidified with HCl, and then immersed for 10–30 seconds in a .1 p.c. watery solution of gold chloride, also acidified with HCl, which it is of advan-

\* Boston Med. and Surg. Journ., 1903, pp. 659–69. See also Zeit. Wiss. Mikr., xx. (1903) pp. 88–9.

† Zeit. Wiss. Mikr., xx. i. (1903) pp. 24–8.

tage to warm to 25° C. The sections are washed in acidified water, and then kept for at least 24 hours in a 50 p.c. watery solution of glycerin. They are then brought into Canada balsam through alcohol and chloroform. This method differentiates non-woody cells, as those of the bast-parenchyma and medullary tissue.

**Vital Staining of Micro-organisms.**—B. Romanoff\* has studied granules in bacteria, moulds and yeasts, by means of vital staining with methylene-blue and neutral red. The property of the latter to lose its colour in the presence of alkalis, and to regain it with acids, makes this stain a delicate indicator of the reaction of the cytoplasm in different parts of the same cell. He finds that in yeast there are granules other than fat and glycogen staining with neutral red. To demonstrate this he grew it in a medium poor in nutrient elements, containing mag. sulph. ; pot. phosph. ; sod. chlorid. ; asparagin ; peptone. Yeast so cultivated contained no glycogen and a minimum of fat.

**Vital Staining of Blood-Plates in Man with "Brillantkresylblau."**—G. Puchberger† stains blood-plates with this dye in less than a minute, and, after the lapse of about a quarter of a hour, a hyaline substance separates itself in spherical form (Hyalomer), but continues connected by a constriction with the remaining, also circular, stained part of the cell (Chromomer). The nuclei of the lymphocytes and the granules of the leucocytes stain in a similar manner, but not so the nuclei of the polynuclear or the large mononuclear cells. In leukaemia are found large blood-plates the size of lymphocytes. These behave in the above described manner. Similar changes occur in lymphocytes, the nuclei of which separate from the protoplasm. The statement that the chromomer of blood-plates corresponds to the nucleus requires proof.

**Iron Carmalum.**‡—J. G. de Groot suggests the following as a useful modification of Mayer's Carmalum. (1) Carminic acid (F. A. Kahlbaum, Berlin So.), 1 grm. ; (2) ammonio-sulphate of iron, .1 grm. ; (3) alum, 5 grm. ; and (4) distilled water, 200 c.cm. To prepare the stain, dissolve No. 1 with warmth in 20 c.cm. water ; add No. 2 and dissolve ; add 180 c.cm. water and warm ; stir in No. 3 ; cool and filter ; add two drops hydrochloric acid, and a crystal of thymol.

It can be used both for bulk staining and for sections.

**Modification of the Uranium Carmine Staining of Schmaus.**—E. Chilesotti§ has devised the following method for staining axis cylinder with carmine. 1 grm. soda carmine (Grübler) is rubbed up with .5 grm. uranium nitrate. The mixture is boiled for half an hour with 100 c.cm. water, then filtered, and before use, a little 1 p.c. hydrochloric acid alcohol is added to the solution (.5–1 c.cm.). Sections hardened in Müller stain in this in 5–10 minutes, those hardened in formalin in 15–20 minutes, in Weigert's neuroglia mordant in 30–60 minutes, and

\* Bull. Soc. Imp. Natur. Moscow, 1903. pp. 581–2.

† Virchow's Archiv., 1903, Heft 2. See Centralbl. Bakt. Ref., xxxiii. (1903) p. 545.

‡ Zeit. Wiss. Mikr., xx. (1903) pp. 21–3.

§ Centralbl. Allg. Path., 1902, p. 193. See also Zeit. Wiss. Mikr., xx. (1903) pp. 87–88.

Marchi sections in 2-4 hours. Sections are then washed in water, alcohol and carbol-xylol. If overstaining has taken place, or if the celloidin is also stained, the sections should be immersed in .5-1 p.c. hydrochloric acid alcohol. This method can be employed with frozen, paraffin or celloidin sections.

**Thermophore for use in Staining.**—A. Hinterberger\* describes a thermophore suitable for methods in which it is desirable to use the staining solutions for periods of time. It consists of a box like a Petri dish, 9 cm. in diameter and 4 cm. high. The lid has on its upper surface a cup-shaped depression for holding the stain. The heat is obtained by first filling the box with sodium acetate or barium hydrate, and then adding cold distilled water. The uncovered dish will maintain for an hour a temperature of from 44° C. to 41° C., or from 54° C. to 51° C. respectively. In the covered dish the cold water poured in soon becomes warm, and the temperature then sinks in about an hour and a half from about 49° C. to 43° C., or from 60° C. to 42° C. respectively. The thermophore, filled with sodium acetate, ought to lie before use for seven minutes in boiling water. If barium hydrate is used the longer it is kept in boiling water the longer it will keep warm.

#### (5) Mounting, including Slides, Preservative Fluids, &c.

**Soluble Glass as Mounting Medium for Examination of Paper.**† C. E. M. Fischer recommends soluble glass for mounting specimens of paper fibres. The paper is first softened in warm distilled water and then reduced to pulp. A piece is then teased out on a slide, and, after the surplus water has been removed, the slide is then held over the flame until just sufficient moisture remains to wet the preparation evenly. A drop of thick soluble glass is placed on the fibres, and then a cover-glass over all. The only inconvenience of this method is frequency of air bubbles, but in other respects it is extremely advantageous.

#### (6) Miscellaneous.

**Microscopical Examination of Paper.**‡—J. Hübner states that it is often of importance to ascertain microscopically the kind or kinds of fibres from which a paper has been made. Pieces of the paper to be examined, taken from various parts of the sheet, are boiled for 10-15 minutes in a weak solution of caustic soda (1 p.c.). The boiled paper is now placed on a fine sieve, washed free from soda. It is then transferred to a bottle containing garnets, and after a short shaking with water, the pulp is drained and is then ready for examination. The principal reagents required are iodopotassic iodide solution and iodozinc chloride solution. The former turns linen, cotton and hemp, light to dark brown; straw and jute cellulose, grey; wood cellulose and esparto, partly grey, partly brown; manila hemp, partly grey, partly brown, partly yellowish brown; wood pulp and raw jute, partly yellow, partly yellowish brown.

\* Zeit. Wiss. Mikr., xx. (1903) pp. 14-16.

† Journ. App. Micr., vi. (1903) p. 2413.

‡ Journ. Soc. Arts, li. (1903) pp. 872-3.

Zinc chloride solution gives the following reactions: Cotton, linen and hemp, claret-red; wood, straw, esparto and jute cellulose, partly blue, partly reddish and blueish violet; manila hemp, blue, blueish violet, dull yellow and greenish yellow; wood pulp and raw jute, lemon to dark yellow. Before applying zinc chloride solution, the pulp must be freed from water by squeezing it on a porous plate. The fibres are then teased out with platinum needles and covered with a thin cover-glass.

The structural characters of the different fibres when inspected under the Microscope are as follows. Cotton fibres appear as flat ribands, usually twisted on themselves. The flax fibre is round and fairly regular, and shows a narrow central canal with numerous dark cross-lines, and the characteristic linen bulbs. Hemp fibres cannot be distinguished from flax fibres. Mechanical wood has a ragged or torn appearance, and its structure is not fibrous. It also shows pitted vessels or pores and cross-markings on many of the cells. The bast fibres of jute are distinguished by a canal, the width of which varies considerably. Wood cellulose fibres are usually flat, often twisted, and not unlike cotton; not infrequently pitted pores are visible. Straw fibres are round and smooth, and accompanied by numerous cuticular cells, some of which are very wide and flat, whilst others are peculiarly marked and serrated. The spiral-shaped cells carry a ring at each end. Esparto fibres and cells are very similar in appearance to straw fibres and cells. The characteristic pear-shaped hairs or cells are, however, always present, and afford a ready means of distinguishing esparto from grass.

**Detection of Trypanosomes.\***—As Trypanosomes are not present in large numbers it is necessary, says A. Castellani, to draw off at least 15 c.cm. of cerebrospinal fluid. It is better to reject the first few cubic centimetres as they are apt to contain blood. When the fluid comes away clear, 10 c.cm. are collected and centrifuged for 15 minutes. The deposit is slight. The sediment, which is whitish, is examined under a moderately low power, and as the trypanosomes are at first fairly active they are easily detected.

D. Bruce and D. Nabarro adopt the same method as the foregoing for examining the cerebrospinal fluid obtained by lumbar puncture. In the case of blood, they found that the presence of the corpuscles was a barrier to detecting the parasites, and it is a curious fact that both filariæ and trypanosomes resist the centrifugal action, and are most readily found after being centrifuged three or even four times. The procedure adopted was to collect 10 c.cm. of blood from a vein, in a test-tube containing a little citrate of potash solution to prevent coagulation. After centrifuging for 10 minutes the clear layer was poured off and again centrifuged, and this procedure was repeated four times, the sediment from each centrifuging being examined microscopically.

**Method for the Investigation of Fossils by Serial Sections.†**—W. J. Sollas points out that the mechanical difficulties which preclude

\* Roy. Soc. Rep. Sleeping Sickness Com., No. 1 (1903) 88 pp. (10 pls.).

† Proc. Roy. Soc., lxxii. (1903) p. 98.

the study of fossils by serial thin sections, may be obviated by means of serial polished surfaces obtained at any desired degree of proximity, and these when the fossil and its matrix offer sufficient optical contrast, serve most of the purposes of thin slices. They may be photographed under the Microscope so as to furnish a trustworthy and permanent record. The sections, which are obtained at intervals of about 0.025 mm., may be also used for reconstructing the fossil in wax.

**Application of the Cinematograph Principle to the Study of Serial Sections.**—B. E. Kelly.\* The tissue is fixed, stained in bulk and imbedded in paraffin. The most convenient width of the paraffin block was found to be three-eighths of an inch. A ribbon is cut, floated on to warm water, and then stuck on to a celluloid film by means of an albuminate fixative. When dry, the paraffin is dissolved in xylol, and the sections are fixed to the film by means of a varnish. A French oil-varnish has been hitherto used. When thoroughly dry, the film is rolled up and placed in a cinematograph apparatus, and the sections are projected on a screen by means of a camera; or the working portion of the cinematograph camera is placed on the stage of a microscopic projection apparatus, or even on the stage of an ordinary Microscope. The advantages claimed by this method are:

1. The ease with which a series of sections can be demonstrated to an audience.
2. The unique impression of continuity.

**Simple Method of Making Collodion Sacs for Bacteriological Work.**†—W. D. Frost uses small test-tubes for this purpose. Thick collodion is poured into the tube to a depth equal to the desired length of the sac. It is then poured out along one side of the tube into another, and then again into another in the same way. The coated tubes are then placed mouth downwards in a rack to drain off excess and to dry. When dry, the sac usually shrinks and may be easily pulled out. The sacs may be kept a long time in water. To sterilise the sac it is three parts filled with bouillon or other medium, and immersed in a tube of the medium. The sac is held in position in the tube by means of the tongue formed by the collodion flowing out of the tube. Before the sac is put in the tube, a piece of cotton or silk is placed round its upper part and loosely knotted, the ends being taken outside the tube. Sterilisation is then effected in the usual way. The medium in the sac is then inoculated with a platinum needle, and the tube incubated for 24 hours. If at the end of this time the medium outside the sac be clear, the integrity of the latter may be accepted. The sac is then pulled out and the cotton or silk drawn tight and tied, and the ends cut off along with the ends of the sac. The mouth is finally sealed with collodion. The sac is then ready for introduction into the body cavity of an animal.

The advantages claimed are: (1) Simplicity; (2) No danger from air bubbles; (3) May be made of any size or shape; (4) No glass to break or irritate the animal; (5) Maximum amount of dialysing surface.

\* Brit. Med. Journ., ii. (1903) pp. 313-4.

† Centralbl. Bakt. 1<sup>te</sup> Abt. Orig., xxiv. (1903) pp. 733-5.

**Bottle for Immersion Oil.\***—A. Schuberg describes a bottle for immersion oil made by W. and H. Seibert of Wetzlar. The neck of the bottle is prolonged upwards into a funnel-shaped expansion, the diameter of which equals that of the bottle itself. The outer edge of this expansion is ground for the reception of a bell-shaped glass capsule. The glass stopper is prolonged downwards into a thin rod, nearly reaching the bottom of the bottle, and ending in a small pear-shaped head. The stopper possesses three deep vertical grooves which permit any excess of oil to run back into the bottle. The advantages claimed are: the oil can be removed without the bottle becoming smeared, and soiling of the grip of the glass rod, etc. is avoided; the quantity used can be easily regulated; all parts can be easily cleaned; and the bottle can be carried about full.

**A Modification of the Pantograph for the Drawing of Microscopical Preparations.†**—F. V. Friedländer has designed a modification of this instrument, in which the angle of the parallelogram, carrying the guiding-pin, is not, as in the stork's-bill, a solid vertical axis, but is a ring-joint of the two limbs of the parallelogram which here meet. This ring is 44 mm. in diameter, and its centre corresponds to what would have been the crossing of the two limbs. It is thus possible to view from above the preparation to be drawn. The guiding pin which follows the contour of the preparation, passes obliquely downwards from one of the limbs of the parallelogram to its position under the ring. Its position can be altered and fixed with a screw, to suit objects of different thickness; the point, however, is always directly under the centre of the ring. The ring is adapted for the reception of a drawing Microscope. The whole apparatus is fixed with a screw to a drawing board, which, for the use of transmitted light with the Microscope, has a piece cut out and covered with glass. The apparatus gives an enlargement of 2–10 diam. The right hand guides the drawing point, while the eye, from above, controls the movement of the guiding point on the preparation.

### Metallography, &c.

**Micrographic Study of Cast Iron.‡**—The distribution of the impurities in cast iron offers many features of interest to the engineer. P. Longmuir has briefly examined some typical cast iron, and reproduces their characteristic structures. He gives a few notes on heat treatment for the production of "black heart" and malleable cast iron.

**Note on the Amphibole Hudsonite previously called a Pyroxene.§** S. Weidman having made thin sections of hudsonite and placed them under the Microscope, it was seen by the prismatic cleavage of  $56^\circ$  and  $124^\circ$  and by the optical properties of low birefringence, strong pleochroism and absorption, that this mineral is an amphibole, and not

\* *Zeit. Wiss. Mikr.*, xx. (1903) pp. 17–20 (1 fig.).

† *Tom. cit.*, pp. 12–4 (1 fig.).

‡ *Page's Mag.*, iii. (1903) pp. 99–104 (8 figs.).

§ *Amer. Journ. Sci.*, xv. (1903) pp. 227–32 (2 figs.).

a variety of pyroxene, as it had always been supposed. Cleavage fragments of the mineral measured by a hand goniometer also readily showed the prismatic cleavage to be that of amphibole.

FAY, H., HIGGINS, A. W., and COBURN, F. W.—Study of the Relations between the Microstructure, the Heat Treatment, and the Physical Properties of Axle Steel. *Technology Quarterly*, XVI. (March 1903) pp. 4-17, 15 figs.

BECKER, A.—*Krystalloptik. Eine ausführliche elementare Darstellung aller wesentlichen Erscheinungen, welche die Krystalle in der Optik darbieten, nebst einer historischen Entwicklung der Theorien des Lichtes.* Stuttgart, 1903. 362 pp. and 106 figs.



## PROCEEDINGS OF THE SOCIETY.

## MEETING

HELD ON THE 21ST OF OCTOBER, 1903, AT 20 HANOVER SQUARE, W.  
DR. HENRY WOODWARD, F.R.S., PRESIDENT, IN THE CHAIR.

The Minutes of the Meeting of the 17th of June, 1903, were read and confirmed, and were signed by the President.

The List of Donations to the Society, exclusive of exchanges and reprints, received since the last Meeting, was read, and the thanks of the Society were voted to the Donors.

Coulter & Chamberlain, Morphology of Angiosperms. (8vo, } New York, 1903) .. .. . }	From <i>The Publishers.</i>
De Toni, J. B., Sylloge Algarum. Vol. iv. Sect. iii. Floridæ. (8vo, Patavii, 1903) .. .. . }	<i>The Author.</i>
Drude, P., The Theory of Optics. Translated from the German by C. Riborg Mann and Robt. A. Millikan. (8vo, London, } 1902) .. .. . }	<i>The Publishers.</i>
Greenish, H. G., The Microscopical Examination of Foods and Drugs. (8vo, London, 1903) .. .. . }	<i>The Publishers.</i>
Report of the British Association for the Advancement of Science, 1902. (8vo, London, 1903) .. .. . }	<i>Frank Crisp, Esq.</i>
Thirty-First Annual Report of the Local Government Board, 1901-2. Containing the Report of the Medical Officer for 1901-2. (8vo, London, 1903) .. .. . }	<i>The Local Government Board.</i>
Catalogue of the Madreporarian Corals in the British Museum (Natural History). Vol. iv. (4to, London, 1903) .. .. . }	<i>The Trustees of the British Museum.</i>
Aquatic Insects in New York State. Being Bulletin 68, Entomology 18, of the New York State Museum. (8vo, Albany, } 1903) .. .. . }	<i>The Directors of the New York State Museum.</i>
Monthly Microscopical Journal, Nos. 1 to 108, 1869-1877. (8vo, London) .. .. . }	<i>Dr. Glaisher.</i>
Journal of the Royal Microscopical Society from 1878-1902. (8vo, London) .. .. . }	
A Microscope, by Negretti and Zambra, and accessories, and a number of Slides belonging to the late James Glaisher, F.R.S. a former President of the Society .. .. . }	

Mr. F. W. Watson Baker exhibited and described Messrs. Watson and Sons' new attachable mechanical stage, which was a simplified form capable of being fixed to almost any ordinary stage by means of a thumb-screw. The plates were made to run between guides instead of in dovetailed grooves, and the motion was given by a brass roller covered with india-rubber, mounted at the end of the stem carrying the controlling milled head. It would be found quite large enough for all ordinary purposes, having a movement of about  $1\frac{1}{2}$  in.

The thanks of the Society were unanimously voted to Messrs. Watson for their exhibit.

Mr. J. W. Gordon exhibited some remarkably fine photo-micrographs of *Pleurosigma Angulatum*, taken with a compounding draw tube fitted with a vibrating screen, such as he had recently exhibited at a Meeting of the Society, and described at p. 420 of his paper published in the August Journal. The instrument employed in producing them was fitted with a  $\frac{1}{4}$ -in. oil immersion as the principal objective, above which a  $\frac{1}{2}$ -in. objective was mounted to act as a magnifier; and the photograph then obtained was further enlarged by the usual camera process. The whole magnification obtained was  $396 \times 24 = 8500 : 1$ . The source of illumination in this instance was a pin-hole lighted by a Welsbach burner. He thought it would be better to use a limelight for the purpose, because with a Welsbach mantle the stitches of the fabric were discernible in the field of the instrument; and, although they were sufficiently large and out of focus not to destroy the details, the somewhat striped effect altered the appearance of the picture as a photograph. (Unfortunately, through some temporary disarrangement of the Epidiascope, an attempt to show the photographs upon the screen was not sufficiently successful to afford any idea of the sharpness of detail so remarkable in the prints, which were therefore handed round for inspection.)

Mr. C. Beck regretted that the photograph did not show to full advantage on the screen, but the original would be found much better; it was of special interest on account of the means by which it had been produced. When it was considered that it had been taken through a ground-glass screen, rapidly oscillated, it was astonishing that the hexagonal markings were clearly shown. Another remarkable thing about it was, that the original image formed by the Microscope had been magnified by another Microscope to the extent of  $\times 150$ , whereas the microscopic image viewed with an A eye-piece is only magnified  $\times 5$ . The result certainly left no doubt that Mr. Gordon had demonstrated the perfect success of his method, which some persons must have looked upon with horror at the time when it was first mentioned.

Mr. J. W. Gordon said that Mr. Beck had referred to a ground-glass screen. He had mentioned this in his former communication, and most of his work had been done with such a screen, but he ought to have said that the particular specimens before the Meeting were taken with a screen formed of a thin film of wax between two cover glasses, which, although not quite so diaphanous as ground glass, had some advantages. He had used this because he had it by him at the time; although it was not better for photography than a ground glass it was certainly better for the eye, as a scintillating effect was produced by ground glass however finely it had been rubbed down. In the wax film, on the contrary, the grain was so inconspicuous that when the screen was set in vibration it wholly disappeared, and with this therefore they got rid of the scintillation altogether.

The thanks of the Society were cordially voted to Mr. Gordon for his communication.

Mr. F. W. Millett's paper "On the Recent Foraminifera of the Malay Archipelago"—being part xv. of the series—which he had contributed to the proceedings of the Society, was taken as read.

Mr. C. D. Soar then exhibited upon the screen a large number of drawings of freshwater mites, and gave a brief explanation of the special characters of each as they were shown. Many of the original specimens from which the drawings were made were exhibited under Microscopes in the room.

The President, in moving a vote of thanks to Mr. Soar, expressed the pleasure which the exhibition had afforded him from the admirable way in which the drawings had been shown and for the care and skill which was displayed in their production. It was a matter for hearty congratulation, which he was sure would be cordially offered by members to the author. The Society was greatly indebted to Mr. Soar, not only for showing them the drawings and explaining them, but also for the exhibition of so many beautiful specimens of Hydrachnea under the Microscopes upon the table.

The thanks of the Meeting were then unanimously voted to Mr. Soar for his demonstration.

Mr. Wesché said he had been much struck during the exhibition of Mr. Soar's drawings by the large number of secondary sexual peculiarities which seemed to exist. He had been under the impression that in most cases these were confined to the neighbourhood of the rostrum, as in the Ticks, but should be glad to hear from Mr. Soar what was the meaning given to the term "genital area," which had been frequently used, and what was the relationship between the "genital area" of the male and that of the female.

Mr. Soar said he did not know that the rostrum was concerned in the act of fertilisation, but he had observed that the third pair of feet had been locked in the genital opening of the male, from which they had dragged out a ball and forced this into the orifice of the female. He perhaps ought to have said the "so-called" genital areas, because he believed that there was no actual contact between these at the time of fertilisation.

The Secretary read a letter from the Croydon Microscopical Society intimating that their Annual Soirée would take place on November 18th, and asking the help of any Fellows of the Royal Microscopical Society who would assist them by exhibiting with their Microscopes on that occasion.

The following Instruments, Objects, &c., were exhibited:—

The Society:—A Microscope, by Negretti and Zambra, formerly belonging to the late Mr. James Glaisher.

Mr. J. W. Gordon:—Photomicrographs of *Pleurosigma angulatum*.

Mr. J. D. Soar:—About fifty drawings of British Hydrachnea, projected on the screen by the Epidiascope.

Mr. Hy. Taverner:—The following slides of British Hydrachnea: *Arrhenurus ornatus* ♂; *Atax intermedius* ♂♀; *A. Taverneri* ♀; *A. ypsilophorus* ♀; *Diplodontus despiciens*; *Hydryphantes dispar*; *Limnesia maculator* ♂♀; *Piona carneus* ♂; *P. fuscatus* ♀; *Wettina macroplica*.

Mr. F. W. Watson Baker:—A New Attachable Mechanical Stage, made by Messrs. Watson & Sons.

Dec. 16th, 1903

3 E

## MEETING

HELD ON THE 18TH OF NOVEMBER, 1903, AT 20 HANOVER SQUARE, W.  
DR. HENRY WOODWARD, F.R.S., PRESIDENT, IN THE CHAIR.

The Minutes of the Meeting of the 21st of October last were read and confirmed, and were signed by the President.

The List of Donations, exclusive of exchanges and reprints, received since the last Meeting, was read, and the thanks of the Society were voted to the donors.

	From
Brearley, H., The Analytical Chemistry of Uranium. (Svo,)	The Publishers.
London, 1903) .. .. .	

Dr. Edward Horder exhibited and described a convenient metal Clinical Case,  $3\frac{3}{4}$  in.  $\times$   $3\frac{3}{4}$  in.  $\times$   $1\frac{1}{2}$  in., which had been made under his instructions by Messrs. Charles Baker, of 244 High Holborn, W.C., and would, he thought, be found extremely useful where weight and space were any consideration, as was always the case when travelling abroad. Instead of using the ordinary 3 in.  $\times$  1 in. glass slips, which were not only heavy, but deteriorated rapidly and soon became useless in hot climates, he mounted his specimens of blood, sputum, &c. between two sizes of cover glasses, and had devised a metal frame (which he showed to the meeting) to hold these when it was desired to examine them under the Microscope.

A small metal case was also exhibited by Dr. Horder holding fifty specimens so mounted, which could easily be carried in the waistcoat pocket.

The Clinical Case contains besides the metal frame a space for slips of glass, a bottle into which two sizes of cover-glasses can be placed in spirit, four bottles for different fixing and staining fluids, spirit lamp, pipette, pestle and mortar, filter funnel, slips of tissue and drying paper, platinum needle, piece of linen, vaseline, xylol balsam, surgical needles, watch-glasses, &c., &c. : also a number of stains in "Soloid" form.

The box and its contents will doubtless be found extremely useful in the tropics, and also to practitioners at home.

Dr. Horder also showed a small rack on which stained specimens can be placed to dry.

Another small box ( $1\frac{3}{4}$  in.  $\times$  1 in.  $\times$   $\frac{3}{8}$  in.) was shown by him which facilitates the collection of blood films in daily practice. It has two compartments, and contains cover-glasses, paper for making smears, needles and platinum wire.

The glass smeared with blood, pus or sputum by the paper, when dry is placed between a slip of tissue paper, which can receive the name of the disease.

The thanks of the Meeting were voted to Dr. Horder for his exhibit and explanation.

**Mr. Taverner** exhibited upon the screen two photographs of the leg of a water mite which he had taken through the separate tubes of a binocular microscope. He said this experiment proved the images seen by each eye were really dissimilar and capable of producing a true stereoscopic effect; if they had been alike the apparent solidity of the object as seen through the binocular would be only a mental effect. He found in this way that there was a sufficient difference between the pictures to produce a proper stereoscopic projection.

The thanks of the Society were voted to Mr. Taverner for his exhibit.

**Prof. J. D. Everett, F.R.S.**, read a "Note" on Lord Rayleigh's paper of 1896, reprinted in the Society's Journal for August, pp. 447-473.

There was one part of the paper in question that he had always found specially difficult, namely that in which the transition is made from direct to oblique illumination of a grating under the Microscope. He had recently succeeded in finding a more direct mode of deducing the results there established; and that mode was set forth in the present communication. Lord Rayleigh, to whom he submitted the "Note" several weeks since, had been too much occupied with some special investigations to look thoroughly into the matter, but said that on cursory examination the new method of deduction seemed to be correct. It is intended to supersede the two pages of the original paper which begin with Equation 32 (where imaginary multipliers make their first appearance) and end with Equation 45.

He proceeded to explain his proof by diagrams and formulæ on the blackboard.

**Dr. Johnstone Stoney** prefaced his remarks by observing that he had for several years been engaged in studying optical problems by a new method, and especially microscopical problems of the kind dealt with in Dr. Everett's paper.

Students of nature did not always sufficiently keep in view the distinction between a hypothesis and a theory. A theory is the best supposition we can form as to what that machinery is which is actually operating in nature; and accordingly theories are correct or incorrect. Their merit is to be true, irrespective of whether we can make much or little use of them. On the other hand a hypothesis involves the supposition that certain artificial machinery is brought into operation, the study of which we have reason to expect will help us forward in our investigation. The hypothetical machinery may be, either that which we suppose to be operating in nature—in which case the hypothesis is also a theory—or, as more frequently happens, it is simpler machinery which we substitute for some more complex operation going on in nature. It is quite sufficient justification for a hypothesis, that we can make good use of it; whereas a theory must aim at being true.

Thus, if our investigation requires us to describe the light which traverses the space between the cover-glass over a microscopic object and the front lens of the objective, which space is filled with some uniform medium, usually air or oil, then the correct theory appears to be, that this light is a mass of undulations, the waves of which consist of alternating electro-magnetic stresses; whereas, it is the usual practice to substitute for this the vastly simpler hypothesis that the light consists of rays. Nobody supposes, or at least ought to suppose, that these hypothetical rays are what really exist; but the substitution of their easily studied machinery for the much less manageable machinery of nature is legitimate, inasmuch as it can be shown that it leads to correct results in a great number of the problems most commonly met with. This hypothesis, upon which the whole of the science of Geometrical Optics is built, is one of the most useful hypotheses of the physicist.

Nevertheless it is desirable that the study of this branch of nature shall also be carried on by making use of the theory of light, and this the speaker had found to be practicable by availing ourselves of a new method of resolution. It is possible to prove that however complex may be the mass of luminous undulations which traverse a space filled with a uniform medium, the whole of this light can be resolved into simple *undulations of flat wavelets, one advancing across the space in every direction in which light traverses it, and each travelling across it without having undergone change while doing so.*

The theorems required for mathematically handling this method of resolving light have been worked out, and it has been found that not only can it deal with problems of optics which lie beyond the grasp of geometrical optics, but that it enables us to treat many problems that have been investigated by the older methods in such a manner as to present to the scientific imagination a singularly distinct picture of what really occurs.

There is no class of problems in which the advantages of the new method are more conspicuous than when we are dealing with the *resolving power* of Microscopes. It at once shows (1) that the limit of resolving power for each wave-frequency of the incident light depends, so far as the instrument is concerned, not on the objective but on the combination consisting of the objective and condenser; (2) that the resolving power has different limits according to the kind of object presented for resolution; (3) that amongst these the only object in respect of which the resolving power is accurately *definite* is a ruling of equidistant parallel lines or a straight row of equidistant dots; and (4) that the limit of resolution of each other kind of object bears an ascertainable relation to this resolution of equidistant lines or dots, which may be called the standard resolution. It also shows the conditions under which the detail upon an object ceases to present the appearance of 'spherules,' and exchanges this appearance for one in which the shape and size of the specks is presented. The limit of the conditions under which this latter appearance is presented is *the limit of fully satisfactory* microscopical vision. It also shows that a single pair of close objects can be seen as two under conditions which are insufficient to resolve a ruling of which the spacing is the same as that of the two

objects ; and that, when this is the case, the two objects will *seem* in the Microscope (or telescope) to be farther asunder than they really are.

These results of the new method are here selected from amongst its many achievements, because they are all susceptible of striking verification by experiments, conducted upon the exquisite rulings upon the under-side of a cover-glass, which have been produced by Mr. Grayson, of Melbourne.

The way in which these experiments were carried out, and the apparatus employed, were then described by the speaker ; and he called special attention to the importance of accurately adjusting the distance between the source of light and the condenser ; but the time at his disposal did not admit of his describing how to make this important adjustment.

In the course of his remarks, he mentioned that he had found details, which he had not seen described, upon the diatom known as *Pinnularia nobilis*. Each of the tongue-like costæ upon this diatom has upon it from six to eight rows of somewhat more closely packed dots, each row extending the whole length of its costa, and the whole presenting an appearance not unlike that upon the tongue-like costæ of the more easily resolved diatom sold under the name of *Eupleuria pulchella*, which seems to be of the same genus as that which Van Heurck calls *Entopyla*, and figures upon page 340 of his Treatise.

Finally, Dr. Stoney expressed his readiness to make arrangements, so far as he could, to show the foregoing experiments to any Fellow of the Society who is specially interested in this branch of microscopical study.

Prof. Everett said that Lord Rayleigh had made reference in his paper (see p. 448) to assistance which had been furnished to him by Dr. Stoney.

On the motion of the President, the thanks of the Society were unanimously voted to Prof. Everett for his paper.

---

Mr. W. Wesché gave a brief resumé of his paper "On the mouth parts of the *Nemocera*, and their relation to the other families of Diptera," which was illustrated by a number of excellent drawings shown upon the screen by the Epidiascope, the last of the series being coloured to show the homologous parts of the mouth organs in different families, as compared with those of the Cockroach, which was taken as a type. By the kindness of Messrs. Baker, of High Holborn, who lent a number of their microscopes, Mr. Wesché was able to show a number of mouth parts of blood-sucking and disease-carrying Diptera ; amongst them were *Glossina morsitans* (nagana disease), *G. palpalis* (sleeping sickness), *Stegomyia fasciata* (yellow fever), and *Anopheles cinereus* (malaria).

The thanks of the Society were cordially voted to Mr. Wesché for his communication, and the explanation given of the plates which had been exhibited. Also for the excellent series of preparations illustrative of the subject exhibited under Microscopes kindly lent for the occasion by Messrs. Baker.

---

The President said he had arranged for two more visits of the Society to the Natural History Museum; the first on Saturday, November 28th, and the second on Saturday, December 5th, when he should be pleased to welcome as many Fellows of the Society as came, and to give them an hour's demonstration on each afternoon, which he hoped would be of interest, the subjects chosen being Fossil and recent Mammals and Reptiles. The party on each occasion would meet at Owen Statue in the Central Hall at 2.30 P.M. This was somewhat earlier than on former occasions, but it had been found necessary to fix this hour as the Museum was closed at this period of the year punctually at 4 o'clock.

**New Fellows.**—The following were elected Ordinary Fellows:—Messrs. George S. Barton, Norbert Van Laer, Arthur Skinner, and Robert Spry.

**The Following Objects, Instruments, &c. were exhibited:—**

Dr. Edward Horder:—Clinical Case fitted with stains, &c., for blood work, and specimen slides, shown under Microscopes, of Leprosy bacilli and *Filaria sanguinis hominis*.

Mr. Taverner:—Lantern slide of the stereoscopic images obtained by photography from the binocular microscope. Enlarged prints of the same exhibited by means of the stereoscope.

Mr. W. Wesché:—Drawings shown on the screen by the epidiascope of the mouth-parts of various blood-sucking flies, and the following slides exhibited under Microscopes, in illustration of his paper:—

*Anopheles cinereus* ♀, host of the malaria parasite; *Ceratopogon pulicaris*, biting midge; *Chrysops cæcutiens*; *Culex pipiens* ♀; *Dinocerites cancer* ♀—the larvæ of this mosquito are parasitic on crabs (Barbados); *Glossina morsitans*, host of the trypanosoma, germ of the nagana disease of horses; *Glossina palpalis*—the bite of this insect causes the "sleeping sickness" in Uganda; *Hæmatobia irritans*, relative of the Tsetse flies; *Leptis scolopacea*; *Melophagus ovinus*, so-called "sheep tick"; *Simulium reptans*, sand fly; *Stegomyia fasciata* ♀, host of the germ of yellow fever; *Tabanus sudelicus*.

**CORRIGENDUM.**

Page 463, line 14 from foot, should read, "according as *v* exceeds or . . . ."



## INDEX.

## A.

Abbado, M., Allescherina and Cryptovalsa, 207

Abderhalden, E., Chemical Action of Growing Fungi, 651

Ablominal Styles, Appendicular Nature, 175

Abel, M., Examining Oligochæte, 106

— Regeneration in Limicolæ, 179

Absidia, Study, 333

Absorption and Secretion in Terrestrial Isopods, 39

*Acanthia lectularia*, Berlese's Bursa in, 36

*Acanthias*, Peculiar Cestode from, 615

*Acanthias vulgaris*, Spermatozoa, 593

Acanthometrea, Observations, 503

Acanthometridæ, Reproduction, 45

Acarina, Thick-skinned, 177

Acetylene Gas Apparatus, 98

Achalme, P., Identification of some Anaerobic Bacteria, 78

Achromatism, Eye-piece Lens Interval, 221

*Achromatium oxaligerum*, 755

Acids, Inactive, Biological Method for Resolving into their Optically Active Components, 533

— Production by Fungi, 752

Acocantherin: an African Arrow-Poison, 508

Acrasiacæ, 752

— Bacteriophagous, 752

Acrosome of Spermatid of Notonecta, 295

Actiniaria of the Olga Expedition, 44

Actinic Light, Some Experiments, 766

Adder, Formation of Zymogen in Gastric Glands, 27

Aders, W. M., Division of *Protohydra leuckarti*, 44

— Spermotogenesis in Hydra and Aurelia, 304

Adipogenic Function of Liver in Invertebrates, 31

Adjustable Clamp and Razor-holder, New, for the Minot Microtome, 234

Adrenalin, Experiments, 285

Adrenaline, 30

Aëriferous Canal in Shell of Certain Pulmonata, 492

African Flora, xxiv., 318

Agaricacææ, Italian, 212

Agarics, Critical, 532

*Agaricus Henriettae*, 532

Agglutinating and Cilio-phagocytic Organs, 31

Agglutination, 78

— by Blood of Emulsions of Microbes, 756

Agriculture and Bacteria, 84

Air, Permeability of Cell-walls, 194

Alaria, New, 636

Albarran, J., Functional Inequality of the Kidneys, 488

Albinism in Birds and Mammals, 712

Albumen, Action of Yeast on, 647

Albuminoids in Plants, Decomposition and Regeneration, 317

Alcock, J., Deep-Sea Life in Indian Seas, 597

Alcohol, Influence on Development, 484

— Production in Seeds, 518

Alcyonidia, and Related Ascorrhiza, 727

Alcyonidium, New Species, 500

Alder, Disease, 644

Aleurodidæ, Vasiform Orifice, 721

Algæ and Peridiniæ, German, 524

— Cultivation Medium, 767

— Fossil, 203

— — from North America, 639

— — — Fresh-water, 326, 629

— — — Action of Salt Water on, 203

— — — British, 326

— — — Formic Aldehyde as a Food-stuff, 316

— — — from South Patagonia, 327

— — — — Zambesi, 327

— — — Nuclear Stains, 630

— — — of certain Lakes, 638

— — — of the Azores, 326

— — — of the North of Ireland, 202

— — — of the Royal Gardens, Kew, 201

— from Central Asia and China, 639

— Javan, 203

— Marine, Catalogue of British, 66

— — from Dago, 67

— — Japanese, 744

— — New Zealand, 68

— — North American, 327

— — of Iceland, 528

— — of Sicily, 638

- Algae, Marine, of the Faeröes, 67  
 — — of the Shetlands, 743  
 — — Polymorphism, 636  
 — Minute, Nitrogenous Metabolism, 623  
 — of Galapagos Islands, 67  
 — of North-Western America, 527  
 — of the Gulf of Naples, 639  
 — Scottish, 203  
 Algal Flora of Russia, Literature, 326  
 Algological Notes, 630  
 Alimentary Canal of Leech, Minute Structure, 612  
 — Tract of Leech, 302  
 — — of Silphidae, 607  
 Alkaloids as a Source of Nitrogen, 737  
 — of *Dicentra formosa*, 732  
 Allen, B. M., Embryonic Development of Mammalian Ovary and Testis, 706  
 Allescher, A., Kryptogamen-Flora: Fungi imperfecti, 209, 535  
 Allescherina and Cryptovalsa, 207  
 Allis, E. P., jun., Lateral Canals and Cranial Bones of *Polyodon folium*, 288  
*Allolobophora fetida*, Sperm Centrosome and Aster, 724  
 Alloys, Certain Properties of the Gold-Silver Series, 375  
 — Effect of Superheated Steam upon Tensile Strength, 683  
 Alma, New Species, 180  
*Alternaria Brassicae* and *Polydesmus exitiosus*, 338  
 Altschüler, E., Enrichment Method for Typhoid Bacilli, 368  
 Amanita, Genus, 72  
 Amar, M., Function of Calcium Oxalate in Plant Nutrition, 515  
 Amber, Diptera, 606  
 Amberg, O., and Others, Fresh-water Algae of certain Lakes, 638  
*Amblystoma tigrinum*, Acceleration and Retardation of Metamorphosis, 707  
 Amitotic Division in Vertebrata, 595  
 Amœba, Nuclear Division, 305  
 Amœbæ and their Cysts, Influence of Light on, 617  
 — Conjugation, 503  
 Amœboocytes, Rôle in *Polymnia nebulosa*, 724  
 Amphibia, Development of Pineal Body, 594  
 — Heterotypic Maturation-Mitosis, 707  
 Amphibians and Reptiles, Biological Observations, 165  
 — Influence of Central Nervous System on Development of Limbs, 594  
 — Retrogressive Changes in Ovarian Follicle, 22  
 Amphion, Genus, 39  
 Amphioxus, Minute Structure, 487  
 — Vascular System, 489  
 Amphipods, Antarctic, 611  
 — North American, 723  
 Amphipods, Terrestrial, Death-Feigning, 723  
 Amphiuma, Intestinal Epithelium, 597  
 Amylomyces  $\beta$ , Research, 204  
*Amylomyces Rouxii*, 68  
 Anabæna, 658  
 Anaerobic Cultivation, 104  
 Ancel, P., Sex Determination of Gametes in Hermaphrodite Gonads, 32  
 — Sexual Differentiation in Hermaphrodite Gland of *Limax maximus*, 718  
 Anderson, K. A., Re-discovery of Cephalodiscus, 303  
 André, G., Nutrition of Plants deprived of their Cotyledons, 624  
 Andres, A., Permeability of Frog's Skin, 30  
 Andrewes, F. W., Resisting Powers of *Staphylococcus pyogenes aureus*, 541  
 Andrews, T., Microscopic Appearances of Volcanic Dust, 374  
 Andrusoff, N., Brackish Water Cocks, 493  
 Anemones and Variation in Metridium, Notes, 45  
 Angewandten Optik, Handbuch der, 102  
 Angiosperms, Morphology, 735  
 — Origin, 625  
 — Recent Investigations in the Embryosac, 53  
 Animal Cells and Yeast, Study of Nuclei, 205  
 Animals and Plants, Arsenic in, 186  
 — Normal Presence of Arsenic in, 488  
 Annandale, N., Eating Habits of *Galeopithecus volans*, 30  
 — Malayan Phasmidæ and a Flower-like Beetle Larva, 36  
 Annelids of the Cete Region, Revision, 498  
 Anodonta, Utilisation of Carbonate of Lime, 718  
 Anomia, Muscular Apparatus, 171  
*Anomodon Toccoæ*, 523  
 Anonaceæ, Anatomy, 51  
 Anopheles in the Iberian Peninsula, 606  
 Ant, Study, 35  
 Antherozoids, Ejection, 521  
 — in Marchantia, Formation, 321  
 Antibodies of Spores of Bacteria, 218  
 Antipodal Cell, Division, and Formation of Egg in Juncaceæ, 736  
 Ants, Hibernation, 719  
 — Sensitiveness to Ultra-Violet and Röntgen Rays, 171  
 Anuropus and Bathynomus, 611  
 Apertometer, Abbe's, Method of Using, 93  
 Apertometry and Focometry, Simple Method, 94  
 Aperture, Numerical, and Rapidity, 765  
 Aphanomyces, Spore-Development, 641  
 Apogamy, Cytology, 740  
 Appendicular Nature of Abdominal Styles, 175

- Appendicularia, Development, 167  
 Apple, Black Spot, 71  
 Apples, Disease, 529  
 Arcangeli, A., Detection of Phosphorus in Plants, 49  
 Arcangeli, G., Notes on Various Fungi, 651  
 Arechavaleta, J., Flora of Uruguay, 57  
 Argutinsky, P., *Plasmodium præcox*, 619  
 Aristolochiaceæ, 519  
 Arkövy, J., *Leptothrix racemosa*, 75  
 Aronson, H., Staining Nervous Tissue with Gallein, 560  
 Arsenic in Animals, 29, 598  
 — in Eggs of Fowl, 488  
 — in Plants and Animals, 186  
 — Normal Presence in Animals, 488  
 Artery, Perforation of Vein by, in Cat, 711  
 Arthur, J. C., Problems in the Study of Plant Rusts, 531  
 — and Another, Cultures of Uredinæ, 530  
 Ascaris, Hind-End, 180  
 — Sense-Organs, 499  
 — Unfertilised Ova in Human Fæces, 614  
 Asclepiadaceæ, Morphological Study, 512  
 Asclepiads, Development of Pollen, 53  
*Asclepius curassavica*, New Disease, 748  
 Ascobacterium, New, from Sugar Cane, 82  
 Ascocarp in Monascus, Morphology and Development, 206  
 Ascomycetes, Epiplasm, 644  
 — Metachromatic Corpuscles, 751  
 — Sexuality, 644  
 Ascorhiza and Related Alcyonidia, 727  
 Ascospores in Erysiphaceæ, Infection-Powers, 645  
 Asexual Reproduction, 628  
 Ashmunella, Variation in Genus, 717  
 Aso, K., Action of Sodium Fluoride and Potassium Iodide and Potassium Ferro-cyanide on Plants, 518  
 — Lime in Phanerogamic Parasites, 192  
 Asparagine, Formation in Metabolism, 192  
 Aspergilleæ Parasitic on Human Beings, 749  
 Assimilation in Green Plants, 514  
 Aster and Centrosome, Sperm, of *Allolobophora fætida*, 724  
*Asteronidium Saccardoï*, 337  
 Asterosteptidæ, 729  
 Asymmetry, Normal, of Wings of *Naucoris cimicoides*, 174  
 Atlantis, Lost, 715  
 Attachable Mechanical Stage, Watson's "Argus," 761  
 Attems, C. Graf, New Myriopods, 297  
 Augener, H., Studies on Gephyrea, 725  
 Aurelia and Hydra, Spermatogenesis, 304  
 Autolytic Processes in Pickled Herring, 31  
 Auxospores of Diatoms, 632  
 Axial Filament in the Adult Connective Tissue Fibril, 596  
 Axis-Cylinders, Staining with Carmin, 107  
 Ayers, H., Morphology among Animals, 487  
 Ayrton, W., New Vorticellid, 504  
 Azolla, Root Development, 520
- B.
- Baar, R., Pacific Horny Sponges, 729  
 Babes, V., Origin of Giant Cells, 597  
 — Parasite of Texas Fever, 618  
 Baccariini, P., Endogone, 332  
 — New Hypomyces, 207  
 Bach, A., Function of Peroxides in the Living Cell, 317  
 Bachmann, H., *Cyclotella bodanica* var. *lemanica*, 634  
 Bachmetjew, P., Calorimetric Measurements in Reference to Pupæ of Lepidoptera, 33  
 Bacilli, Acid-fast, in *Pythion reticularis*, 660  
 — Differentiation of True and False Diphtheria, 366  
 — Presence of strictly Anaerobic Butyric Acid, and of other Anaerobic Species in Hard Cheese, 661  
 — Typhoid, Enrichment Method, 368  
 — Typhus, Rapid Diagnosis, 343  
 Bacillus, Acid-fast, Disease of Rat caused by, 660  
*Bacillus aerogenes aerophilus agilis*, 81  
 — — *capsulatus* in Circulating Blood, 82  
 — *coli* and *Bacillus typhosus*, Differentiation, 367  
 — — *communis* and *Bacillus typhi abdominalis*, Differentiation, 80  
 — — — Method of Detecting the Presence in Shellfish, 229  
 Bacillus, Cultivating the Influenza, 105  
 — Diphtheria and Pseudo-Diphtheria, Differentiation, 343  
 — — Group, New Pathogenic Microbe, 343  
*Bacillus Diphtheriæ*, Differential Stain, 370  
 — *icteroides*, New Method of Isolating, 767  
 Bacillus, Influenza-like, from Dog, 342  
 — — — from Rat, 342  
 — New Red Pigment-forming, 342  
 — of Epidemic Dysentery, 659  
 — of Leprosy, 218  
 — of Soft Sore, 83  
*Bacillus typhi abdominalis* and *Bacillus coli communis*, Differentiation, 80  
 Bacillus, Typhoid, Immunising Effects of Contents, 541  
 — — Intracellular Toxin, 217  
*Bacillus typhosus*, Action of Alcoholic Fermentation, 80  
 — — and *Bacillus coli*, Differentiation, 367  
 — *vascularum* and Gummosis, 82

- Bacteria, Acid-Rennet-forming, in Milk, 77
- Anaerobic, Biology, 340
  - — Cultivation, 340
  - — Identification, 78
  - and Agriculture, 84
  - and Particles, Ultra-Microscopic, On the Rendering Visible, 573
  - and Saccharomycetes, Cell-Nucleus, 68
  - Antibodies of Spores, 218
  - Denitrifying, Accumulation Experiments, 539
  - Destruction of Non-nitrogenous Organic Substances, 216
  - Diarrhoea-producing, Chemical Products, 755
  - Easy Method of Staining Flagella, 237
  - Effect of Oil, 340
  - in Daily Life, 219
  - in Pus from a Gas-containing Abscess, 341
  - Luminous, 756
  - Method of Mounting from Fluid Media, 561
  - Nitrogen-assimilating, 659
  - Nitrogen-fixing, 540
  - of Leguminous Tubercles, Question of Species, 342
  - of Milk-ducts of Cow, 83
  - Parasitic in Intestine of Chironomus Larvæ, 294
  - Passage through Filters, 341
  - Penetration of Plants, 216
  - Physiology of Spore-formation, 339
  - Pigment, of Water, 341
  - Psychrophilic, 79
  - Structure, 79
  - Thermophilous, 539
- Bacterial Granules, Method for Staining, 237, 371
- Light, Experiments, 662
  - Origin of Vegetable Gums, 339
- Bactericidal Action of Ultra-Violet Radiations, 756
- Bacteriological Examination, Apparatus for Collecting Samples of Earth, 104
- Technique, Eyre's, 374
- Bacteriology, 218
- of Natural Mineral Waters, 83
- Bacteriophagous Acrasidæ, 752
- Bacterium coli*, Epidemic of Guinea-pigs caused by a Variety, 342
- Bacterium, Colourless, obtaining Carbon from the Air, 340
- Bacterium Fragi*, 81
- Bacterium, New Gum, 77
- — in freshly-drawn Milk, 343
  - Pathogenic for House-Rats, 341
- Bagnall, J. E., *Ricciolepus natans*, 323
- Bagshaw's 'Elementary Photomicrography,' 101
- Bain, S. M., Manipulation of Sections of Leaf-Cuticle, 770
- Baker, F. C., Monstrosities in Bivalves, 33
- Rib Variation in Cardium, 718
- Baker, F. W. W., Messrs. Watson and Sons' new Attachable Mechanical Stage, 779
- New Pattern Portable Microscope, 562
- Baker, R. T., Leaf-Venation and Chemical Constituents of Eucalypts, 50
- Balaton, Microscopic Fresh-water Animals, 716
- Balicka-Iwanowska, G., Decomposition and Regeneration of Albuminoids in Plants, 317
- Bambeck, V., Nuclear Behaviour and Spore-Formation in *Hydnangeum carneum*, 750
- Bananas, Disease, 70
- Bancroft, T. L., Intermediate Host of *Filaria immitis*, 40
- Bandi, J., New Method of Isolating *Bacillus icteroides*, 767
- Bandi, W., Experiments with Pucciniæ, 649
- Barbier, M., Study of Fungi, 212
- Barbour, W. C., Lejeunea in North America, 322
- North American Hepatics, 59
- Barbour's Pocket Magnifier, 91
- — Microscope, 90
- Barker, B. T. P., Morphology and Development of the Ascocarp in *Monascus*, 206
- Barley and Malt, Micro-organisms, 216
- Barnard, J. E., Luminous Bacteria, 756
- The Bactericidal Action of some Ultra-Violet Radiations as produced by the Continuous-Current Arc, 756
- Barrett-Hamilton, G. E. H., Flight of Flying Fish, 288
- Barsali, E., Italian Hepatics, 322
- Barsanti, L., Cause of Floral Zygomorphism, 52
- Bartarelli, E., Tubes for the Preparation of Aerobic and Anaerobic Cultures under the Influence of Coloured Rays, 768
- Bartels, E., *Cysticercus fasciolaris*, 181
- Barus, —, Method of Demonstrating Newton's Colours by Transmitted Light, 672
- Basidiomycetes, Presence of a Kinase, 533
- Research, 211
- Bastian, H. C., Chlorochytrium, 631
- Spores of Vaucheria, 631
- Batelli, —, Adrenaline, 30
- Bateson, W., Mendelian Heredity, 706
- Bather, F. A., New Crinoid, 43
- Bathynomus and Anuropus, 611
- Bats, Genital Apparatus, 711
- Batters, E. A. L., Catalogue of British Marine Algae, 66
- Scottish Algae, 203
- Bauer, V., Metamorphosis of Nervous System in Insects, 604

- Bäumler, J. A., Cryptogamic Flora of Presburg, 536
- Bausch and Lomb, New Pattern Microscope, 244, 349
- Bavay, A., Aëriferous Canal in Shell of certain Pulmonata, 492
- Beard, J., Embryology of Tumours, 705  
— Germ-Cells and Germinal Continuity, 22
- Beauverie, J., Structure of *Botrytis cinerea*, 647
- Beck, C., 248, 569, 780  
— Spinthariscopes, 563  
— and Andrews, H., Photographic Lenses, 677
- Beck's Metallurgical Microscopes, 348  
— Pathological Microscope, 346  
— Portable Continental Model, 544  
— — "Star" Microscope, 345  
— Process Microscope, 346
- Beer, R., Chromosomes of *Funaria hygrometrica*, 628
- Bee, Wax-making Organ, 719
- Beecher, C. E., The Genus *Romingeria*, 729
- Bees, Microbe of "Loque" Disease, 77
- Beetle, Cœlomic Gregarine, 307  
— Embedded in Wall of Human Intestine, 720  
— Larva, Flower-like, and Malayan Phasmidæ, 36
- Beetles, Development of Wings, 293  
— of Ireland, 176
- Béguin, F., Structure of Digestive Canal in Reptiles, 163
- Behrens, J., Retting of Flax and Hemp, 661
- Behrens, W., Apparatus for Decanting off Culture Fluids, 557
- Beijerinck, —, Colourless Bacterium obtaining Carbon from the Air, 310
- Beilby, —, 569
- Bell, F. J., Antaretic Echinoderms, 303
- Belloc, E., Diatoms from Morocco, 744
- Benecke, W., Culture of Hepatics, 321
- Bennett, A., Equisetum hyemale, 195
- Bensley, R. R., Brunner's Glands, 709
- Bentivoglio, T., *Galaxaura adriatica*, 637
- Berg, W., Contributions to the Theory of Fixation, with Particular Regard to the Cell-Nucleus and its Albuminous Bodies, 770
- Bergendal, D., *Callinera bürgeri*, 182
- Bergevin, E. de, Interconversion of Sexual Organs in a Moss, 59
- Bergh, R., Opisthobranchs from Gulf of Siam, 32
- Bergmann, W., Gonads of *Ilesione sicula*, 613  
— Structure of Ovary in Cephalopods, 490
- Bermuda Islands, 626, 716
- Bernard, N., Germination of Orchids: a Symbiotic Relationship, 737
- Bernard, N., Physical Conditions of Tuberculation in Plants, 54
- Berry, E. W., American Species of Thinnfeldia, 738
- Bertacchini, P., Development and Structure of Vitreous Humour, 163
- Bertrand, G., Arsenic in Animals, 29  
— — in Eggs of Fowl, 488  
— Normal Presence of Arsenic in Animals, 488
- Besançon, F., Bacillus of Soft Sore, 83
- Bessey, C. E., Conjugatæ, 201
- Bethe, A., Cell-Division, 161
- Beyer, H., Anatomy of Anonacæe, 51
- Bezier, T., Albinism in Birds and Mammals, 712
- Bibliography, 90, 91, 100, 102, 103, 105, 114, 115, 226, 229, 234, 239, 240, 373, 374, 560, 622, 623, 624, 627, 674, 678, 681, 684, 734, 737, 740, 743, 744, 753, 754, 763, 764, 766, 778
- Biérix, E., Emergence of Lobster Larvæ, 723
- Billard, A., Excretory Cells in Hydroids, 616  
— Observations and Experiments on *Clava squamata*, 44
- Billings, F. H., Chalazogamy in *Carya oliviformis*, 313
- Binocular Microscope, New, 85
- Biogen-Hypothesis, 285
- Biological Laboratory Methods, 240  
— Method for Resolving Inactive Acids into their Optically Active Components, 533
- Bipaliidæ, Contributions to Study, 182
- Bipalium Species, Studies, 41
- Bird and Man, 602
- Bird-Embryo, Torsion of, 161
- Birds and Mammals, Albinism, 712  
— Blood-Vessels of Spinal Cord, 487  
— Classification, 286  
— Follicular Epithelium, 594  
— How they make themselves understood by Man, 602  
— of North and Middle America, 286
- Birefringence, Improved Method of Identifying Crystals in Rock Sections by use of, and Improved Polarising Vertical Illuminator, 683
- Biserial Arm, Development in Certain Crinoids, 728
- Bivalves, Monstrosities, 33
- Blackman, V. H., Germination of Teliospores, 210  
— The Pyrocystæe, 62
- Black-Rot of Grapes, 209
- Black-Spot of the Apple, 71
- Blanchard, L. F., Cœlomic Gregarine in a Beetle, 307
- Blood-Corpuseles, New Method of Counting, 680  
— — Red, Structure, 596

- Blood-Films and the Triacid Stain, Fixation, 229  
 Blood-Plates in Man, Vital Staining with "Brilliantkresylblau," 773  
 Blood-Vessels of the Spinal Cord of Birds, 487  
 Boas, J. E. V., *Triplotenia mirabilis*, 181  
 Bodin, E., Action of Alcoholic Fermentation on the *Bacillus typhosus*, 80  
 Body-Form, Development of External, 24  
 Boeke, J., Minute Structure of Amphioxus, 487  
 Bohlin, K., Centronella and Phæodactylon, 200  
 — Fresh-water Algæ of the Azores, 326  
 Bohn, G., Influence of Radium Rays on Ova, 483  
 — — — — — on Tadpoles, 483  
 Boistel, A., New French Lichen Flora, 70  
 Bokorny, T., Action of Yeast on Albumen, 647  
 — Assimilation of Yeasts, 55  
 — Nature of Protoplasm and Enzymes, 624  
 — Yeast Ferment, 56  
*Boletus Brosianum*, 212  
 — *subtomentosus*, 746  
 Boley, P., Very Powerful Micrometric Microscope, 761  
 Bolton, B. M., Rapid Method of Hardening and Imbedding Tissues, 768  
 Bone, Cancellous, Preparing Sections, 769  
 Bones, Vomerine, Phylogeny, 710  
 Bounier, J., New Type of Salpa-Chain, 490  
 — Two New Types of Epicaridæ, 178  
 Bordas, L., Alimentary Tract of Silphidæ, 607  
 — Mandibular Glands of Larval Lepidoptera, 495  
 — Structure of Gizzard of Carabidæ, 296  
 Bordin, A., Species of Mosquitos concerned in Diffusion of Malaria, 37  
 Borge, O., Fresh-water Algæ from South Patagonia, 327  
 Borgert, A., New Tripylea, 45  
 Børgesen, F., Marine Algæ of the Færøes, 67  
 — Marine Algæ of the Shetlands, 743  
 — Phyttoplankton of Lakes in the Færøes, 744  
 Börner, C., Joints of the Walking Legs in Insects and Myriopods, 604  
*Bornetina Corium*, 650  
 Bornmüller, I., Flora of Ferro, 626  
 Borzi, A., Seeds of Inga, 513  
 Bos, J. R., *Botrytis parasitica*, 209, 529  
 Bösenberg, W., Monograph on German Spiders, 38  
 — Spiders of Germany, 497  
 Boston Testing Laboratories, Illuminating Apparatus for Metallography, 97  
 Botany, Australian Notes, 57  
 Botany of the Ceylon Pantanas, 739  
 Bothriocephalus in Baltic Herring, 615  
*Bothriotenia proboscidea*, Life-History, 42  
 Botrychium, 320  
*Botryosporium pulchellum*, Taxonomic and Cytological Notes, 750  
*Botrytis cinerea*, Structure, 647  
 — *citricola*, 648  
 Botrytis, New Parasitic, 71  
*Botrytis parasitica*, 209, 529  
 — *vulgaris* on Figs, 529  
 Bottini, A., Italian Mosses, 324, 524  
 Bouchard, C., Experiments with Adrenalin, 285  
 Boudier, M. E., Genus Amanita, 72  
 Bouilliac, E., Formic Aldehyde as a Food-stuff for Fresh-water Algæ, 316  
 Bouillon, Sugar-free, Method of Preparing, 767  
 Bouin, P., Spindle-Residues in Cell-Division, 162  
 Bounhiol, J. P., Study of the Respiratory Exchanges in Water, 600  
 Bourguet, A., New Arrangement for avoiding Injury to Preparations when Focusing with Powers, 220  
 Bourguet's New Index Ocular, 91  
 Bourquelot, E., Hydrolysis of Polysaccharides, 517  
 Bourne, C. C., New Molgulid, 602  
 — Some New and Rare Corals from Funafuti, 616  
 Boutan, L., Innervation of Mantle of Pecten, 33  
 Bouvier, E. L., Modes of Development in Onychophora, 297  
 Bouygues, M., Existence of a Pith in the Leaf-Stalk of Phanerogams, 509  
 Bowden, H., A Lens Pseudoscope, 762  
 Bradley, O. C., Muscles of Mastication in Lacertilia, 712  
 Bower, F. O., Morphology of Spore-producing Members; General Comparisons and Conclusion, 318  
 Bradypus, Notes on Development and Structure, 24  
 Brain of *Isistius brasiliensis*, 289  
 Braithwaite, R., British Moss Flora, 323  
 Brand, C. J., *Stappia cylindrica*, 630  
 Brand, F., Cyanophyceæ, 754  
 — Osmotic Properties of Cells of Cyanophyceæ, 658  
 Brauer, A., So-called "Telescopic" Eye of Some Abyssal Fishes, 164  
 Bréal, E., Experiments with Potatoes, 516  
 Bremer, W., Fat-destroying Fungi of Seeds, 534  
 Bresadola, J., Fungi Polonici, 535, 654  
 Briarley, H., Analysis of Steel-Works Materials, 375  
 Briosi, G., Fungus Diseases in Italy, 213  
 — New Parasitic Fungi, 206

- Briscoe, Dr. J. C., New Portable Microscope, 543, 562
- Britton, E. G., Sematophyllum in North America, 196
- and Others, American Mosses, 742
- Brizi, U., *Botrytis citricola*, 648
- Brizi, V., New Parasitic Botrytis, 71
- Perforation of Vine-Leaves, 71
- Broman, I., Circulation in Embryonic Stomach, 595
- Bromes, Experiments on the Brown Rust, 72
- Bronstein, J., Differentiation of the Diphtheria and pseudo-Diphtheria Bacillus, 343
- — of True and False Diphtheria Bacilli, 366
- Broom, R., Phylogeny of Vomerine Bones, 710
- Broughton, S., Decantation Method for Cleaning Diatoms, 679
- Brown, E. E., Variations of Garter Snakes, 601
- Brown, R. N. R., Atlantic Plankton, 526
- Bruce, D., Detection of Trypanosomes, 775
- Brues, C. T., Development of Stylopidae, 494
- Brunner's Glands, 709
- Bruntz, L., Excretion in Cirripedia, 299
- Excretory Organs in Malacostraca, 38
- Labial Excretory Organs and a Phagocytic Organ in Diplopoda, 177
- Bruyne, C. de, Follicular Cells in Gonads of Gastropods, 492
- Bryopsis plumosa*, 329
- Brzezinski, J., Canker of Fruit Trees, 652
- Bubák, F., Cultures of Uredineæ, 210
- New or Critical Species of Uromyces, 531
- Phycomyces, 641
- *Rhizoctonia violacea*, 748
- and Others, American Mycology, 536
- — Notes on Uredineæ, 749
- Buehltz, F., Fungi hypogæi, 651
- Buckleya quadriala*, Parasitism, 51
- Budding and Fission in Madreporearia, Significance, 45
- Buffa, P., Fauna of Alpine Lakes, 167
- Bühler, A., Retrogressive Changes in Ovarium Follicle of Amphibians, 22
- Buhlert, H., Question of Species in Bacteria of Leguminous Tubercles, 342
- Bulman, G. W., Insects and Petal-less Flowers, 604
- Bundle Arrangement in Petiole and Leaf-Veins in Dicotyledons, 509
- Burekhardt, R., Historical Aspects of Zoology, 487
- Bürger, O., Commensalism between Sea-Anemone and Crab, 728
- Burgerstein, A., Movement of Perianth Leaves of Tulip and Crocus, 191
- Burkhardt, R., Brain of *Isistius brasiliensis*, 289
- Bursa, Berlese's, in *Acanthia lectularia*, 36
- Buscalioni, L., Mercerisation of Cotton Fabrics, 520
- Use of Collodion for Detecting Transpiration, 514
- Buttel-Keepen, H. v., *Distomum clavatum*, 182
- Butterflies, Dimorphic Spermatozoa, 605
- of Borderland between North and South America, 34
- Protective Resemblance, 719
- Seasonal Dimorphism, 35
- Butters, F. K., *Trichoglaea lubrica*, 637

## C.

- Cæcal Appendix, Concomitant Absence, and Meckel's Diverticulum, 710
- Calcareous Pebbles, 658
- Calcium Oxalate, Function in Plant Nutrition, 515
- Callinera burjeri*, 182
- Caloglossa Leprieurii*, 66
- Calorimetric Measurements in Reference to Pupæ of Lepidoptera, 33
- Calvet, L., New Species of Alcyonidium, 500
- Calyptopogon, 196
- Cambage, R. H., Notes on Australian Botany, 57
- Cambarus, Habits, 723
- Camera, Koristka's Simplified Vertical, 355
- Lucida, Koristka's Abbe, with Leus-Holder, 554
- Vertical Microphotographic, Improvements, 101
- Cameron, J., Development of Pineal Body in Amphibia, 594
- Campbell, D. H., Recent Investigations in the Embryo-sac of Angiosperms, 53
- Camus, F., French Moss Flora, 61
- Canaliculi in Ganglion Cells, 708
- Intracellular, in Suprarenal Capsules, 597
- Canals, Lateral, and Cranial Bones of *Polyodon folium*, 288
- Cancellous Bone, Preparing Sections, 769
- Canker of Fruit Trees, 652
- Canidae, Ancestral, 711
- Carabidae, Structure of Gizzard, 296
- Carabus, Phylogeny, 493
- Carazzi, D., Berlese's Bursa in *Acanthia lectularia*, 36
- Carbohydrate Reserves, Variation in Stem and Root of Woody Plants, 191
- Carbon tetrachloride as a Clearing Fluid, 370
- Carbonic Acid Gas, Influence on Growth, 189

- Carboniferous Epoch, Vegetative Activity, 513
- Cardamine, Monograph of the Genus, 626
- Cardium, Rib Variation, 718
- Carditacea, Synopsis, 171
- Cardot, J., Mosses of Alaska, 324
- Carinaria mediterranea*, Storing-Kidney, 717
- Carlren, O., Actiniaria of the Olga Expedition, 44
- Carlsson, A., Marsupial Region of Marsupialia, 710
- Carmin, Staining Axis-Cylinders, 107
- Carruthers, W., 562, 563, 570
- Carterius Stepanowi*, 617
- Cartilage-Cells, Structure, 27
- Cartilage, Structure and Development, 163
- Carya olivæformis*, Chalazogamy, 313
- Caryophyllaceæ, Anatomy of Certain Groups, 510
- Casares-Gil, A., *Homalia lusitanica*, 523
- Case, E. C., American Pelycosauria, 601
- Cast Iron, Micrographic Study, 777
- Castellani, A., Detection of Trypanosomes, 775
- Etiology of Sleeping Sickness, 344
- Trypanosoma found in Sleeping Sickness, 504
- Castration in Man, Results, 707
- Casuarina, Development of Ovule, 736
- Caterpillar, New Case of Protective Mimicry, 494
- Changes in Imagines induced by Change of Diet, 294
- Precocious Development of Pupal and Imaginal Organs, 605
- Catherinea, 523
- Cats, Polydaetylous, Prepotency, 24
- Catterina, G., Flagellated Micrococcus found in a Septicæmia of Rabbits, 663
- Caulley, M., Gall-forming Copepod in an Anemone, 300
- Phagocytic Absorption of Sex-Cells in *Echinocardium cordatum*, 727
- Cauloglossum transversarium*, 532
- Caoutchouc-yielding Landolphiæ of the French Congo, 49
- Cavara, F., Observations on the Nucleolus, 49
- Rare Sicilian Fungi, 535
- Cavers, F., Asexual Reproduction, 628
- Biology of Hepaticæ, 629
- and Others, Ejection of Antherozoids, 521
- Cedar Oil and Paraffin, Simple Device for Carrying Minute Objects through the Grades, 230
- White, Fungous Diseases, 75
- Cell, Action of Fermentation on, 745
- Living, Function of Peroxides, 317
- Cell-Division, 161
- — Spindle Residues, 162
- — Theory, 26
- Cell-Membrane of Desmidiaceæ, 65, 328
- Cell-Nucleus and its Albuminous Bodies, Contributions to the Theory of Fixation, 770
- — of Saccharomycetes and Bacteria, 68
- Celloidin, Imbedding, 770
- Sections, Apparatus for Facilitating the Manipulation, 238, 377
- — Improvements of Aubertin's Method for Sticking, 769
- Cell-sap, Specific Gravity, 186
- Cells, Formative Elastic Structures, 709
- Ganglion, Canaliculi, 708
- Growing, Effect of Temperature, 507
- of Plant, Nuclei contrasted with those of Unicellular Animals, 47
- of Uredineæ, Changes produced in, 749
- Cell-walls, Permeability to Air, 194
- Cement, Injurious Effect upon Objectives, 762
- Cementite and Ferrite, Simultaneous Presence in Steel, 683
- Centipede, New Clasp-Organ, 496
- Centronella and Phæodactylon, 200
- Centrosome and Aster, Sperm, of *Allolobophora fetida*, 724
- Nature of, 283
- Cephalodiscus, Re-discovery, 303
- Cephalopod, Remarkable Young Form, 716
- Cephalopods, Chorion and Mycropyle, 168
- Spermatogenesis, 717
- Statocysts, 716
- Structure of Ovary, 490
- Ceramiaceæ, Reparation of Injury, 637
- Cereals, Rusts, 648
- Cerianthid, Adult Pelagic, 44
- Cervidæ, Integumentary Organs, 284
- Cestode, Peculiar, from *Acanthias*, 615
- Chætognatha, Mid-water, Distribution in North Atlantic, 725
- Chætomium Bostrychoïdes*, 206
- Chætophoraceæ and Ultrichaceæ of United States, 65
- Chalazogamy in *Carya olivæformis*, 313
- Chamberlain, C. J., Embryogeny of *Zamia*, 310
- Mitosis in *Pellia*, 620
- Morphology of Angiosperms, 735
- Chapin, P., Influence of Carbonic Acid Gas on Growth, 189
- Chapman, F., Red Rain, 682
- Characeæ of Mark Brandenburg, 202
- Charrin, A., Reappearance in Offspring of Lesions artificially induced in the Mother, 22
- Chauveaud, G., New Secretory Apparatus in Conifers, 621
- Cheel, E., Notes of Australian Botany, 58
- Cheese, Hard, Presence of strictly Anaerobic Butyric Acid Bacilli and of other Anaerobic Species, 661



- Chelonians, Phylogeny, 712  
 Chemical Defence and Other Adaptations in North African Orthoptera, 174  
 Cheshire, F. J., Method of Using Abbe's Apertometer, 93  
 — Simple Form of Reflecting Polariser, 99  
 — — Method of Focometry and Apertometry, 94  
 Chestnut Trees, Disease, 333  
 Chevalier, A., Caoutchouc-yielding Landolphia of the French Congo, 49  
 — Monograph of the Myricaceæ, 57  
 Chevreux, E., Abyssal Lysiannassids, 611  
 — Marine Species of Hyaella, 178  
 Chiasma, Optic, in Teleosts, 287  
 — — of Reptiles, 285  
 Chick, E., Seedling of *Torreya Myristica*, 621  
 Chick, H., Nitrogenous Metabolism in Minute Algæ, 623  
 Chilesotti, E., Modification of the Uranium Carmine Staining of Schmaus, 773  
 — Staining Axis-Cylinders with Carmin, 107  
 Chilodon, New Species, 46  
 Chironomus Larvæ, Parasitic Bacteria in Intestine, 294  
 Chitinous Cuticle, Morphological Significance, 33  
 Chiton, Function of Subradular Organ, 492  
 Chlorogen, Typical, of Oligochaeta, 300  
*Chorella vulgaris*, Cultivation, 328  
 Chlorochytrium, 631  
 Choanophora, New England, 641  
 Chodat, R., Function of Peroxides in the Living Cell, 317  
 Cholera Vibrios and Diphtheria Bacilli, Staining, 235  
*Chondria crassicaulis*, Vegetative Reproduction, 330  
*Chordaria flagelliformis* and *Cystoclonium purpurascens*, 527  
 Chorion and Micropyle in Cephalopods, 168  
 — Formation in *Pyrhocoris apterus*, 607  
 Chromatin, Behaviour in Segmentation of Ovum of Gyrodactylus, 615  
 Chromatophores, Nature and Development, 167  
 Chromosomes, Behaviour in Spore-Mother-Cells of Higher Plants, 505  
 — of *Funaria hygrometrica*, 628  
 — of Hybrids, Behaviour, 505  
 — Reconstruction and Formation in Somatic Nuclei, 505  
 — Reduction, 732  
 Chrysanthemums, Nutrition, 737  
 Chrzaszcz, —, Micro-organisms of Barley and Malt, 216  
 Chun, C., Nature and Development of Chromatophores, 167  
 Chun, C., Remarkable Young Form of Cephalopod, 716  
 Chytridiaceæ, New, 333  
 Ciaccio, C., Intracellular Canaliculi in Supra-renal Capsules, 597  
 — Method of Demonstrating the Secretary Canaliculi in Suprarenal Capsules, 235  
 — Secretary Processes in Suprarenal Capsules, 709  
 Cilia, Compound, 77  
 Cilio-Phagocytic and Agglutinating Organs, 31  
 Cinematograph, Application of the Principle to the Study of Serial Sections, 776  
*Ciona intestinalis*, Arctic Variety, 602  
 — — Function of Ganglion, 489  
 Circulation in Embryonic Stomach, 595  
 Cirripedia, Excretion, 299  
 Citron, E., Minute Structure of *Syncoryne sarsii*, 44  
 Citrus, Leaf, and Crystal-Cells, 732  
 Cladocera, Synopsis of British Fresh-water, 497  
 Cladonias, Notes, 538  
 Clamp-Connections and Fusion in Uredineæ, 750  
 Clasp-Organ, New, in Centipede, 496  
 Claude, H., Experiments with Adrenalin, 285  
 Clausilia, Synopsis of Palæarctic Forms, 492  
*Clava squamata*, Observations and Experiments, 44  
 Claviceps, Infection Experiments, 746  
*Claviceps purpurea*, 207  
 — — Observations on the Ergot of, 747  
 Clinical Case, Metal, 782  
 Clos, D., Theory of the Petiole in the Flower, 52  
 Clute, W. N., and Others, North American Pteridophyta, 521  
 Cobelli, R., Hibernation of Ants, 719  
 — Stridulation of Death's-Head Moth, 34  
 Coccaceæ, Demonstration of Flagella, 109  
 Coccidia, Progress in Study, 730  
 Coccidiau, New, 185  
*Coccus lactis viscosi* and the Causes of Sliminess and Threads in Milk, 216  
 Cockerell, T. D. A., Variation in the Genus *Ashmuella*, 717  
 Cockles, Brackish Water, 493  
 Cockroaches, Palæozoic and Recent, 296  
 Coco, A. M., Nerve-Endings in White Muscle, 284  
 Cocoons of Earthworm, 40  
 Cœlentera from Intermediate Waters of North Atlantic, 304  
*Cœnomyces consueus*, 641  
 Cohn, E., Research of Klein's Yeast, 647  
 Cohn, L., Notes on Trematodes, 500  
 Coker, W. C., Gametophytes and Embryos of Taxodium, 734

- Coker, W. C., Spore-Cavity Nucleus in Prothallia of Marsilia, 320  
 — Two Egg-Cells in Mnium, 323  
 Col, M., Bundle Arrangement in the Petiole and Leaf-Veins in Dicotyledons, 509  
 Cole, R., *Bacillus aerogenes capsulatus* in Circulating Blood, 82  
 Coleoptera, Coloration, 720  
 Collectors, Handbook of Instructions for, 110  
 Collins, F. S., North American Marine Algæ, 327  
 Collodion Sacs for Bacteriological Work, Simple Method of Making, 776  
 — Tubes, Method of Making, 112  
 — Use of, for Detecting Transpiration, 514  
 Colony-Counter, New, 113  
 Coloration, Abnormal, in Pleuronectids, 166  
 — of Coleoptera, 720  
 — of Myxinoids, 599  
 — Unilateral, with Bilateral Effect, 601  
 Colour, Change in Trout, 713  
 — Characters, Determination of Dominance in Hybrids, 619  
 — Illumination of Microscopic Objects, 671  
 — of Silk, 35  
 Coloured Rays, Tubes for Preparation of Aerobic and Anaerobic Cultures under Influence of, 768  
 Colour-Patterns in Lepidoptera, Evolution, 291  
 Colour Photography, Sanger-Shepherd Process, 121  
 Colour-Physiology of Higher Crustacea, 609  
 Colours, Floral, and Insects, 718  
 — of Fishes, 28  
 — of Northern Gamopetalous Flowers, 739  
 Comère, J., Action of Salt Water on certain Fresh-water Algæ, 203  
 Commensalism between Sea-Anemone and Crab, 728  
 Compositæ, Notes, 513  
 Condenser, Stand, 379  
 — Use of, and Illumination in Histological Micrography, 97  
 Conifer Wood from the Turf-Pits, 50  
 Conifers, New Secretory Apparatus, 621  
 Conjugatæ, 201  
 Conjugation and Senescence in Infusorians, 503  
 — of Amœbæ, 503  
 Conklin, E. C., Cause of Inverse Symmetry, 706  
 Connective Tissue, Transformation of Epithelium into, 597  
 Conrady, A. E., 248  
 Conrady, W. A. E., Numerical Aperture and Rapidity, 765  
 Constantin, —, *Sterigmatocystis pseudo-nigra*, 338  
 Conte, A., Budding of *Rhabdopleura normanni*, 42  
 — Colour of Silk, 35  
 — Dipterous Parasite of the Vine-Pest *Haltica*, 606  
 — Nuclear Emissions in Protozoa, 305  
 Continental Model, Beck's Portable, 544  
 Continuity of Protoplasm, 47  
*Convoluta Roscoffensis*, Bionomics, 725  
 Convolvulaceæ, Laticiferous Tissue in Flowers, 513  
 Cooke, M. C., British Mycology, 533  
 — Pests of the Flower-Garden, 75  
 Copeognathæ from Kameroun, 721  
 Copepod, Gall-forming, in an Anemone, 300  
 — New Genus, 497  
 Copepoda from Faroe Channel, 612  
 Copulation in Spiders, 609  
 Corallium, Species, 616  
 Corals, Some New and Rare, from Funafuti, 616  
 Corbière, L., Fossombronia, 322  
 — Riella, 59  
*Cordiceps Robertsii*, 69  
 Corpus Vitreum, Development, 283  
 Correction Distance of an Objective, Graphic Representation, 762  
 Correns, —, Determination of Dominance in the Colour Characters of Hybrids, 519  
 Correns, C., On the Characters of Hybrids, 739  
 Cotte, J., Ingestion of Food-Particles in *Sycandra raphanus*, 304  
 — Metabolism in Sponges, 304  
 Cotton, A. D., Wild Plants as Nurseries of Plant Disease, 653  
 Cotton Fabrics, Mercerisation, 520  
 Cotton, W. A., Behaviour of Nuclei in Plant Hybrids, 506  
 Cotyledons, Nutrition of Plants deprived of their, 624  
 — Stomata, 515  
 Coulter, J. M., Embryogeny of *Zamia*, 310  
 — Morphology of Angiosperms, 735  
 — Origin of Angiosperms, 625  
 Council, New, 122  
 — Report for 1902, 122  
 Counting Corpuscles of Blood, New Method, 680  
 — Red Corpuscles of Blood, 240  
 Coupin, H., Culture of *Sterigmatocystis nigra*, 651  
 — Nutrition of *Sterigmatocystis nigra*, 338  
 Courant, —, Preputial Glands of Rabbit, 486  
 Cowles, R. P., Notes on *Polygordius*, 301  
 Crab and Sea-Anemone, Commensalism, 728  
 Crane Fly, Giant, Larva, 36  
 Cranial Bones of *Polyodon folium*, Lateral Canals, 288

- Crawley, H., Myxosporidian Parasite of Geophilus, 618  
 Crayfish, Function of Mid-Gut Gland, 178  
 — Ventral Nerve-Cord, 299  
 Crenothrix, Genus, 215  
 Cricket of Aquatic Habits, 36  
 Crinoid, New, 43  
 Crinoids, Development of Biserial Arm, 728  
 Crisia, Embryonic Fission, 726  
*Cristiceps argentatus*, Artificial Fertilisation of Ova, 593  
 Crocus and Tulip, Movement of Perianth Leaves, 191  
 Crosbie, F., Staining Directions for Photomicrography, 234  
 Crosby, C. M., *Dictyosphaeria favulosa*, 630  
 Cross M. I., and Cole, M. J., 'Modern Microscopy,' 111  
 Crossland, C., British Hepaticæ, 198  
 Crozals, A., French Volcanic Muscinæ, 323  
 Crucifers, Double Fertilisation, 53  
 Crustacea and Pantopoda, 178  
 — Higher, Colour-Physiology, 609  
 Cryptogams, Swiss, 199  
 Cryptovalsa and Allescherina, 207  
 Crystal-cells and Leaf of Citrus, 732  
 Crystals in Rock Sections, Improved Method of Identifying by use of Birefringence, and Improved Polarising Vertical Illuminator, 683  
 — Making Preparations of, for Micropolariscope, 110  
 Cucumber-Leaf Disease, 748  
 Cuckoo-Spit, Food-Canal of Larva, 174  
 Cuénot, L., Agglutinating and Ciliophagocytic Organs, 31  
 Cugini, G., Sclerospora, 332  
 Cultivating Influenza Bacillus, 105  
 Cultivation, Anaerobic, 104  
 — Medium for Algæ, 767  
 — of Truffles, 643  
 Cultivations, Anaerobic, 367  
 Culture Fluids, Apparatus for Decanting off, 557  
 Cultures, Anaerobic Plate, 366  
 — Aerobic and Anaerobic, Tubes for Preparation under Influence of Coloured Rays, 768  
 Cumings, E. R., Evolution of Platystrophia, 615  
 Cumming, M., New Bacterium in Freshly-Drawn Milk, 343  
 Curtis, C. L., New Monochromatic Light Apparatus, 378, 674  
 Curtis, W. C., Life-History and Reproduction of *Planaria maculata*, 614  
 Curvature of the Spine in Fishes, 161  
 Curvatures of Roots, Thigmotropic, 192  
 Cushing, H., Course of the Taste-Fibres, 286  
 Cushman, J. A., Desmids from Bridgewater (Mass.), 327  
 — Localised Stages of Growth, 51  
 Cuttle-fishes, New, 168  
 — — Oxidising Ferments in Ink, 490  
 Cyanophyceæ, 754  
 — Osmotic Properties of Cells, 658  
*Cybister ræselii*, Spermatogenesis, 36  
 Cycads, Meriphyte, 733  
*Cyclops strenuus*, Maturation-Phenomena in Oogenesis and Spermatogenesis, 39  
 Cyclostomes, Studies, 599  
*Cyclotella bodanica* var. *lemanica*, 634  
*Cymbalopora bulloides*, 185  
 Cypers, V. v., German Mosses, 61  
 Cysticerci, Minute Structure, 182  
*Cysticercus fasciolaris*, 181  
*Cystoclonium purpurascens*, and *Chordaria flagelliformis*, 527  
 Cytology and Physiology of Endophytic Mycorrhiza, 213  
 — of Apogamy, 740  
 — of Yeast, 205, 335, 646  
*Cytoryctes vaccinzæ*, Nature, 307  
 Czapek, —, Proteid-Formation in Moulds, 534  
 Czapek, F., Nitrogen Assimilation in Moulds, 190  
 — Proteid-Formation in Moulds, 528  
 Czaplewski, E., Cultivating the Influenza Bacillus, 105  
 Czapski, S., 565, 569  
 Czermak, N., Fertilisation in Salmon, 160

## D.

- Daday, E. v., Microscopic Freshwater Animals of Balaton, 716  
 Daguillon, A., Distribution of Hairs on the Surface of the Stem, 52  
 Dahl, F., Copulation in Spiders, 609  
 Dairy Products, Fungi, 534  
 Dale, E., Observations on Gymnoasceæ, 646  
 Dall, W. H., Synopsis of Carditacea, 171  
 Damany, P. le, Evolution of Vertebrate Limbs, 708  
 Dandeno, J. B., Effects of Water and Aqueous Solutions on Foliage Leaves, 315  
 Dangeard, P. A., Laws of Division, 283  
 — New Chytridiaceæ, 333  
 — Nuclear Division of Amœba, 305  
 — Observations on *Monas vulgaris*, 618  
 — Protascus, A New Genus, 332  
 — Sexuality of the Ascomycetes, 644  
 — Structure of *Trepomonas agilis*, 306  
 Daniel, L., Experiments on Grafted Plants, 511  
 — Modification of Habit by Grafting, 510  
*Daphne Laureola*, Localisation of Daphniae, 187

- Daphnia, Note on Phototropism, 497  
 Daphnine, Localisation in *Daphne Laureola*, 187  
 Darkness and Light, Influence on Plant-life, 316  
 Darwin, F., Statolith Theory of Geotropism, 515  
*Dasya elegans*, Vegetative Reproduction, 66  
 Davis, B. M., Oogenesis in Saprolegnia, 642  
 — Origin of the Sporophyte, 640  
 Davis, J. H., British Moss Flora, 60  
 Davis, J. R. A., Memoir on the Limpet, 491  
 Davis Shutter, Origin, 99  
 Dean, B., Biometric Evidence bearing on Theory of Limb-Origin, 24  
 — Coloration of Myxinioids, 599  
 — Origin of Paired Limbs of Vertebrates, 29  
 Dean, G., Disease of the Rat caused by an Acid-fast Bacillus, 660  
 Death-Feigning in Terrestrial Amphipods, 723  
*Debarya immersa*, 201  
 Decalcification Method, 558  
 Decantation Method for Cleaning Diatoms, 679  
 Decanting off Culture Fluids, Apparatus, 557  
 Decapods, Deep-Sea, Integumentary Sense-Organs, 299  
 Deckenbach, C. v., *Cænomyces consuens*, 641  
 Deegener, P., Post-embryonic Development of Intestine, 493  
 Deep-Sea Life in Indian Seas, 597  
 Defalle, W., Antibodies of Spores of Bacteria, 218  
 Deflandre, C., Adipogenic Function of Liver in Invertebrates, 31  
 Delacroix, G., Black-rot of Grapes, 209  
 — Diseases of Bananas, 70  
 — — of Vanilla, 70  
 — Phytopathology, 653  
 — Rust on Vanilla, 72  
 Delage, Y., Agency of Carbon Dioxide in inducing Artificial Parthenogenesis, 21  
 — Carbonic Acid as a Provocative of Artificial Parthenogenesis, 21  
 — Notes on Physiological Injections, 285  
 Delamare, G., Reappearance in Offspring of Lesions artificially induced in the Mother, 22  
 Delden, — v., Colourless Bacterium obtaining Carbon from the Air, 340  
 Delesseriaceæ, New Genus, 66  
 Delezenne, C., and Another, Presence of a Kinase in Basidiomycetes, 533  
 Della Torre, R. W. v., Lichen Flora of the Tyrol, 70  
 Denitrifying Bacteria, Accumulation Experiments, 539  
*Derris uliginosa*, Poisonous Action and Histology of Stem, 520  
 Desmidiaceæ, Cell-Membrane, 65, 328  
 Desmids from Bridgewater (Mass.), 327  
 De Toni, G. B., Diatom Records, 635  
 De Toni, J. B., Florideæ, 638  
 Development, Influence of Alcohol, 484  
 Device for Carrying Minute Objects through the Grades of Cedar Oil and Paraffin, 230  
 Diarrhœa-producing Bacteria, Chemical Products, 755  
 Diaschiza, On the Genus, 117  
 — The Rotatorian Genus, 1, 129  
 Diatom, Blue, 330  
 — Records, 635  
 Diatomaceæ of the Hull District, 63  
 Diatoms, Auxospores, 632  
 — Classification, 331  
 — Decantation Method for Cleaning, 679  
 — Endochrome, 633  
 — Fossil, 635  
 — — in Rome, 200  
 — — of Auvergne, 525  
 — Fresh-water, 330  
 — from Morocco, 744  
 — Hungarian: Lake Balaton, 200  
 — Lincolnshire, 526  
 — New Genera, 744  
 — New Genus, Licmosphenia, 64  
 — of Auvergne, 634  
 — of Koh Chang, 330  
 — of Lake Cotronia, 200  
 — of the Atlantic, 634  
 — of the Black Sea, 199  
 — Polynesian, 331  
 — Preparation, 768  
 — Pyrenoids and Elæoplasts, 200  
 — Structure and Division, 632  
 — — and Life-History, 525  
*Dicentra formosa*, Alkaloids, 732  
 Dichodontium, 523  
*Dichotomosiphon tuberosus*, 329  
 Dicotyledons, Bundle Arrangement in Petiole and Leaf-Veins, 509  
 — Development of Embryo of Some, 188  
*Dictyosphaeria favulosa*, 630  
 Diedicke, H., Relationship between Pleospora and Helminthosporium, 747  
 Dietel, P., Japanese Fungi, 74  
 — Rusts of Leguminosæ, 531  
 — Uromyces of Lupins, 650  
 Diffraction Grating, Michelson Echelon, 228  
 Digby, L., Cytology of Apogamy, 740  
 Digestive Canal in Reptiles, Structure, 163  
 Dimorphism of Spermatozoa, 23  
 — Organic Sexual, in Fowls, 160  
 — Seasonal, in Butterflies, 35  
 — — Notes, 494

- Dinosaur, Largest known, 287  
 Diphtheria Bacilli and Cholera Vibrios, Staining, 235  
 Diplopoda, Labial Excretory Organs and a Phagocytic Organ, 177  
 Dipnoans, Permian, Peculiar Modification, 715  
 Dipnoi and Ganoids, "Larynx," 600  
*Dipodascus albidus*, Development, 69  
 D'Ippolito, G., Comparative Anatomy of the Stem in Magnoliaceæ, 51  
 Diptera from Amber, 606  
 — Teeth, 606  
 Dipterous Parasite of the Vine-pest *Haltica*, 606  
*Dipylidium caninum* in Man, New Case, 499  
 Disciscoda, Species, 532  
*Discoglossus pictus*, Development of Lungs, 707  
 Discomycetes, New, 334  
 Disease, Cucumber-Leaf, 748  
 — *Monilia*, 529  
 — New, of *Asclepias curassavica*, 748  
 — of Apples, 529  
 — of Grasses, 751  
 — of the Alder, 644  
 — Salmon, 755  
 Distefano, S., Nerve-Endings in White Muscle, 284  
*Distomum clavatum*, 182  
 — *cygnoides*, American Representatives, 182  
 Distomum, New, from Sawfish Shark, 500  
*Distomum variegatum*, American Representatives, 41  
 Division, Laws, 283  
 Dixey, F. A., Notes on Seasonal Dimorphism, 494  
 — Seasonal Dimorphism of Butterflies, 35  
 Dixon, H. H., Resistance of Seeds to High Temperatures, 624  
 Dixon, H. N., British Moss Flora, 60  
 — *Dichodontium*, 523  
 Dixon-Nuttall, F. R., The Rotatorian Genus *Diaschiza*, 1, 129  
 Dollo, L., Phylogeny of Chelonians, 712  
*Dolomedes fimbriatus*, Development, 298  
 Donard, E., New Proteid from Maize, 49  
 Doncaster, L., Rearing Later Stages of Echinoid Larvæ, 183  
 Dop, P., Development of Pollen in *Asclepiads*, 53  
 Dopter, C., Bacillus of Epidemic Dysentery, 659  
 Dörner, H. B., Effect of Composition of Soil on Plants, 190  
 Dorylinæ, Guests, 172  
 Douin, I., Papillate Hepatics, 322  
 — *Sphaerocarpus terrestris*, 522  
 — and Others, European Hepaticæ, 742  
 Dowdy, S. E., Colour Illumination of Microscopical Objects, 671  
 Dowdy, S. E., Making Preparations of Crystals for the Micropolariscope, 110  
 — Reagent Bottle, 558  
 — Slide for Pond Life, 239  
 Drawing Apparatus, Tubeuf's, 763  
*Drepanidotænia tenuirostris*, 499  
 Dreyer, G., Differentiation of *Bacillus typhosus* and *Bacillus coli*, 367  
 — Influence of Light on *Amœbæ* and their Cysts, 617  
 Dreyling, L., Wax-making Organ of Bee, 719  
 Drone-Ova, History of Polar Bodies, 293  
 Drones, Spermatogenesis, 719  
 Drude's Theory of Optics, 765  
 Drugs and Foods, Microscopical Examination, 561  
 Dry-rot and other Wood-destroying Fungi, 211  
 Drysdale, C. V., 568  
 Dubois, R., Origin of Pearls in *Mytilus gallo-provincialis*, 291  
 — Purple of Dog-Whelk, 170  
 Duboscq, O., Development of Gregarines, 619  
 — New Parasite of Hermit-Crabs, 730  
 — New Species of *Alma*, 180  
 — Sexual Reproduction of *Pterocephalus*, 729  
 Duce, A., Stingless Bees (*Melipona*) of Pará, 172  
 Dudley, P. H., *Lentinus lepilius*, 73  
 Duerden, J. E., Significance of Budding and Fission in *Madreporaria*, 45  
 Dufour, H., Sensitiveness of Ants to Ultra-Violet and Röntgen Rays, 171  
 Durig, A., Electrical Criterion of Vitality, 599  
 Durrand, A., Report on the Recent Foraminifera of the Malay Archipelago collected by, 253  
 Dusén, P., Mosses of East Greenland, 325  
 Dyar, H. G., Lepidoptera of North America, 495  
 Dysentery, Epidemic, *Bacillus*, 659

## E.

- Earland, A., *Cymbalopora bulloides*, 185  
 Earth, Apparatus for Collecting Samples for Bacteriological Examination, 104  
 Earthworm, Cocoons, 40  
 Eastman, C. R., Peculiar Modification in Permian Dipnoans, 715  
 Eberhard, G., The Injurious Effect of Cement upon Objectives, 762  
*Echinocardium cordatum*, Phagocytic Absorption of Sex-Cells, 727  
*Echinococcus alveolaris*, 181  
 Echinoderms, Antarctic, 303  
 — List of Irish, 728

- Echinoderms of East Finmark, 728  
 Echinoid Larvæ, Rearing Later Stages, 183  
*Echinus microtuberculatus*, Experimental Studies on Eggs, 501  
 Ecklonia and Eisenia, 329  
 Edwards, C. L., Note on Phrynosoma, 488  
 Eel Question, Solution, 25  
 Egg, Bird's, Fibrinogenic Substance in Albumen, 31  
 Egg-Cells, Two, in Mnium, 323  
 Egg, Formation, and Division of Antipodal Cell in Juncaceæ, 736  
 — Mammalian, Fixation in Uterine Cavity, 769  
 — Newt's, Influence of Salt Solution on Early Development, 593  
 Eggs of *Echinus microtuberculatus*, Experimental Studies, 501  
 — of Fowl, Arsenic in, 488  
*Egretta Menziesii*, 635  
 Ehrlich Triacid Solution, Modification of the Method of Staining, 560  
 Eichholz, W., *Bacterium Fragi*, 81  
 Eigenmann, C. H., Solution of the Eel Question, 25  
 — Unilateral Coloration with Bilateral Effect, 601  
 Eijkman, C., Milk-Agar as a Medium for the Demonstration of the Production of the Proteolytic Enzyme, 679  
 Eisenia and Ecklonia, 329  
 Elaoplasts and Pyrenoids in Diatoms, 200  
 Elastic Fibres, Stain for, 109  
 Electric Arc, New Method of Using in Photomicrography, 276, 377  
 Electrical Criterion of Vitality, 599  
 — Microscope Lamp, New, 350  
 Elliott, L. B., New Projection Apparatus for Scientific Work, 549  
 Ellis, D., Demonstration of Flagella in Coccaceæ, 109  
 — Observations on Sarcina, Streptococcus and Spirillum, 540  
 Ellrodt, G., Penetration of Plant by Bacteria, 216  
 Elmastian, M., Demonstrating Trypanosomata, 371  
 Embryo and Gametophytes of Taxodium, 734  
 — of some Dicotyledons, Developments, 188  
 Embryogeny of *Ficus hirta*, 313  
 — of *Zamia*, 310  
 Embryology, Comparative and Experimental, Treatise, 483  
 — Comparative of the Swim-Bladder, 708  
 — Laboratory Text-Book, 483  
 — of Tumours, 705  
 — of Vertebrates, Treatise on Comparative and Experimental, 160  
 Embryonic Fission in Genus *Crisia*, 726  
 Embryos, Human, Interscapular Gland, 29  
 Embryo-Sac of Angiosperms, Recent Investigations, 53  
 Emmerling, O., Chemical Action of Growing Fungi, 651  
 — Destruction of Non-nitrogenous Organic Substances by Bacteria, 216  
 Encyclopædia of Microscopical Technique, 373  
 Enderlein, G., Copcognathæ from Kamearon, 721  
 — Normal Asymmetry of the Wings in *Nauoris cimicoides*, 174  
 Endochrome of Diatoms, 633  
 Endogone, 332  
 Endothelial Derivatives † and Pigment-Bodies in Gephyreans, 613  
 Endris, W., *Pilostyles Inqæ*, 188  
 Engelke, C., *Claviceps purpurea*, 207  
 — Observations on the Ergot of *Claviceps purpurea*, 747  
 — *Sceptromyces Opizi*, 209  
 Engelmann's Microspectral Objective with Detachable Thorp's Grating and Detachable Polariser, 351  
 — Microspectralphotometer with Grating Spectrum, 359  
 Engler, —, African Flora, 626  
 Enrichment Method for Typhoid Bacilli, 368  
 Enriques, P., Adaptability of Marine Infusorians to Fresh Water, 306  
 Enteropneusta, Heart, 42  
 — Movements, 43  
 Entomology, Economic, 721  
 Entoprocta, Pacific Coast, Studies, 727  
*Entosiphon Deimatis* Parasitic in an Abyssal Holothuroid, 491  
 Enzyme in Ripening Plantains, 56  
 — Rennet-like, from Yeast, 528  
 Enzymes and Protoplasm, Nature, 62‡  
 — Nomenclature, 517  
 Epidaridæ, Two New Types, 178  
 Epiplasm of Ascomycetes, 644  
 Epithelium, Follicular in Birds, 59‡  
 — Intestinal in Amphiuma, 597  
 — Transformation into Connective Tissue, 597  
*Equisetum hyemale*, 195  
 Ergot of *Claviceps purpurea*, Observations, 747  
 Eriksson, J., Mycoplasma Hypothesis, 749  
 — *Rhizoctonia violacea*, 748  
 — Specialisation of Rusts, 72  
 Erinaceidæ, Phylogeny, 167  
 Ernst, A., *Dichotomosiphon tuberosus*, 329  
 — Nuclear Reduction and Fertilisation in Paris and Trillium, 48  
 Ernst, E., New Genus of Siphonæ, 64  
 Erysiphaceæ, Infection-Powers of Ascospores, 645  
 — Notes, 206 335

- Erysipheæ, Studies, 747  
 Escherich, K., Development of Nervous System in Muscidae, 37  
 — Studies on Thysanura, 295  
 Esmarch, E. v., Passage of Bacteria through Filters, 341  
 Esteva, J., Abnormal Growths in Woody Plants, 511  
 Etching Reagent, new, for Polished Steel Sections, 682  
 Ether as a Narcotising Medium for Aquatic Animals, 368  
 Eucalypts, Leaf-Venation and Chemical Constituents, 50  
 Evans, A. W., Hepaticæ of Puerto Rico, 323  
 — Muscinæ of the Galapagos Islands, 62  
 — North American Hepatics, 59, 743  
 Evans, R., New Species of Peripatus, 608  
 Everett, J. D., 564, 785  
 — 'Note' on Lord Rayleigh's Paper of 1896, 783  
 Ewart, A. J., On the Physics and Physiology of Protoplasmic Streaming in Plants, 308  
 Ewing, J. A., Fracture of Metals under repeated Alterations of Stress, 115  
 Excretion in Gnat Larvæ, 173  
 Excretory Cells in Hydroids, 616  
 — Organs in Malacostraca, 38  
 — Processes in Insects, 34  
 Exhibition of Drawings and Slides of British Hydrachnea, 781  
 Exuvial Glands in Insects, 173  
 Eycleshymer, A. C., Early Development of Lepidosteus, 708  
 — Nuclear Changes in Striped Muscle-Cell of Necturus, 27  
 Eye-piece, Lens Interval as arranged for Achromatism, 221  
 Eyes, Compound, of Machilis, 608  
 Eyre, J. W. H., Bacteriology, 218  
 Eyre's Bacteriological Technique, 374
- F.
- Fabre-Domergue, —, Emergence of Lobster Larvæ, 723  
 Fahringer, J., Storing-Kidney in *Carinaria mediterranea*, 717  
 Falck, R., Oidium Production and the Culture of the Higher Fungi, 75  
 Farlow, W. G., Algæ of the Galapagos Islands, 67  
 — Fungi from Galapagos, 214  
 — Lichens from Galapagos, 209  
 — Muscinæ of the Galapagos Islands, 62  
 Farmer, J. B., Cytology of Apogamy, 740  
 — Reduction of Chromosomes, 732  
 Farneta, R., Polymorphism of Microfungi, 209  
 Farneti, R., *Boletus Briosiumum*, 212  
 Farneti, R., New Parasitic Fungi, 206  
 Fauna of Alpine Lakes, 167  
 — of Indo-Australian Archipelago, History, 598  
 — Relict, of Lake Furesö, 289  
 Faust, E. S., Acocantherin: an African Arrow-Poison, 508  
 Fauvel, P., Ootocysts of Polychæta, 301  
 Feinberg, L., Nuclei of Unicellular Animals contrasted with those of Plant Cells, 47  
 Feinberg, —, Study of Nuclei in Yeast and Animal Cells, 205  
 Felt, E. P., Aquatic Insects of New York State, 722  
 — Grape-vine Root-Worm, 177  
 Femoral Glands of Lizards, 27  
 Fermentation, Action on the Cell, 745  
 — of Milk, Researches, 756  
 Ferments, Industrial, of Eastern Asia, 337  
 — Oxidising, in Ink of Cuttle-fishes, 490  
 — Proteolytic, 625  
 Fern Study in North America, 58  
 Fernandez, D., Pigment Bacteria of Water, 341  
 Ferns, Cuban, 58  
 — and Fern Allies of North America, 195  
 Ferraris, J., and Others, Fungus Diseases, 653  
 Ferraris, T., Fungus Flora of Piedmont 535  
 — Fungi of Piedmont, 73  
 Ferrite and Cementite, Simultaneous Presence in Steel, 683  
 Fertilisation and Spore-Ripening in Mosses, 522  
 — in Plasmopara, 745  
 — in Salmon, 160  
 — in Sclerospora, 642  
 — Phenomena in *Hæmenteria costuta*, 498  
 Feyfer, —, de, Paratyphoid Fever, 344  
 Fibrillar Continuity of Epithelial Cells and Muscles in *Nebalia*, 38  
 Fibrinogenic Substance in Albumen of Bird's Egg, 31  
 Ficker, M., Method for Staining Bacterial Granules, 371  
 — New Method of Staining Bacterial Granules, 237  
*Ficus hirta*, Embryogeny, 313  
*Fidia viticida*, Grape-vine Root-Worm, 177  
 Field, A. M., Study of an Ant, 35  
 Figs, *Botrytis vulgaris*, 529  
*Filaria immitis*, Intermediate Host, 40  
 — *medinensis*, Life-Span, 614  
 — *perstans*, 302  
 Fine Adjustment, Leitz' New, and Stand, 665  
 — — Two-speed, 19, 117  
 — Adjustments, Modern, 221  
 Fink, B., Notes on Cladonias, 538  
 Fir Trees, Disease, 334

- Fischer, C. E. M., Soluble Glass as a Mounting Medium for the Examination of Paper, 774
- Fischer, E., Researches on Rusts, 72
- Swiss Cryptogams, 199
- Fischerella, New Species, 76
- Fish, Flying, Flight, 288
- Fishes, Abyssal, So-called "Telescopic" Eye, 164
- Colours, 28
- Curvature of Spine, 161
- Fresh-water, Gill-Filters, 714
- — Marine Parasites in, 499
- — of Borneo, 289
- Hermaphroditism, 282
- Marine, Hematozoa in, 46
- Ovarian Ova and Follicles, 594
- Sense of Hearing, 713
- Size of Nerve-Fibres, 284
- Fission and Budding in Madreporaria, Significance, 45
- Fitzgerald, M. P., Differentiation of *Bacillus typhosus* and *Bacillus coli*, 367
- Fitzgerald, W. V., Notes on Australian Botany, 58
- Fixation, Contributions to the Theory, with Particular Regard to the Cell-Nucleus and its Albuminous Bodies, 770
- Fixing and Imbedding Dense Connective Tissue, 369
- Flabellum, Notes on Variation, Protandry, and Senescence, 184
- Structure and Development, 184
- Flagella in Coccaceæ, Demonstration, 109
- New Method of Staining, 235
- of Bacteria, Easy Method of Staining, 237
- of Tetanus Bacillus, Observations, 663
- Staining, 370
- Flagellate Parasites in Siphonophora, 306
- Flat-Fishes, Skeletal Changes in the Course of Development, 25
- Flax and Hemp, Retting, 661
- Fleure, H. J., Memoir on the Limpet, 491
- Floating Properties of certain Phycchromaceæ, 339
- Flora, African, 626
- Amazon, 626
- and Plant Formations of South Bulgaria, 57
- Chinese, 57, 193, 519
- Cryptogamic, of Presburg, 536
- German, 519
- of Ferro, 626
- of New Jersey, Strand, 193
- of Uruguay, 57
- Floral Distribution in the Alpine Zone, 57
- Structure of Juglandeæ, 314
- Florideæ, 638
- Germination, 331
- Spiral Arrangement, 66
- Flosculariadeæ, Morphology, 727
- Flot, L., Foliar Origin of the Stem, 508
- Flower Garden Pests, 75
- Flowers, Abnormal, of *Helonium autumnale*, 623
- and Insects, 604
- Gamopetalous, Colours of Northern, 739
- Petal-less, and Insects, 604
- Fluke, Peculiar, 303
- Foà, A., Nature of *Cytorhynchus vaccinzæ*, 307
- Focometry and Apertometry, Simple Method, 94
- Focussing in Photomicrography, New Method, 677
- with High Powers, New Arrangement for avoiding Injury to Preparations, 220
- Foix, A., Study of the Respiratory Exchanges in Water, 600
- Foliage Leaves, Young, and Seed Leaves, Protection, 51
- Food-Canal of Larvæ of Cuckoo-Spit, 174
- Foods and Drugs, Microscopical Examination, 561
- Foot, K., Cocoons of Earthworm, 40
- New Method of Focussing in Photomicrography, 677
- Sperm Centrosome and Aster of *Allolobophora fetida*, 724
- Foraminifera of Raised Reefs of Fiji, 306
- of the Malay Archipelago collected by Mr. A. Durrand, Report on, 253, 377, 685, 780
- Forbes, —, Chinese Flora, 193
- Forbes and Hemsley, Chinese Flora, 57
- Forel, A., Sensitiveness of Ants to Ultra-Violet and Röntgen Rays, 171
- Forest Destruction in the United States, 520
- Forgan, W., Modern Fine Adjustments, 221
- Formic Aldehyde as a Food-Stuff for Fresh-water Algæ, 316
- Formica, Pseudogyny and its Cause, 172
- Forti, A., Diatom Records, 635
- Fresh-water Diatoms, 330
- Fossils, Method for Investigation by Serial Sections, 775
- Fossombronia, 322
- Foulerston, A. G. R., Streptothrix, 215
- Fouquieriaceæ, Revision of the Family, 738
- Fowls, Carnivorous. Modifications observed, 286
- — of the Second Generation, 282
- Organic Sexual Dimorphism, 160
- Fracture of Metals under repeated Alterations of Stress, 115
- Francis, E., Ring Test for Indol, 366
- Frankland, P., Bacteria in Daily Life, 219
- Frankland, W. A., Vinegar Eel in Human Bladder, 40
- Freeman, E. M., Experiments on the Brown Rust of Bromes, 72
- Seed-Fungus of *Lolium temulentum*, 75



- Freeman, R., The Rotatorian Genus *Diaschiza*, 1, 117, 129
- Freezing, Action on Plant-Cells, 508
- Apparatus, Molisch's New, 103
- Plate for Hand Microtome, New, 558
- Fremlin, H. S., Anaerobic Plate Cultures, 366
- Culture of the Nitroso-Bacterium, 540
- Freundenreich, E. v., Nitrogen-assimilating Bacteria, 659
- Friedberger, E., Influenza-like Bacillus from a Dog, 342
- Friedländer, F. V., A Modification of the Pantograph for the Drawing of Microscopical Preparations, 777
- Fritsch, F. E., Fresh-water Algae of the Royal Gardens, Kew, 201
- *Cedogonium*, 65
- Phytoplankton of the Thames, 63
- Young Plants of *Stigeoclonium*, 201
- Frost, W. D., Simple Method of Making Collodion Sacs for Bacteriological Work, 776
- Fruit in Malvaceæ, Biology, 313
- of *Jacquinia ruscifolia* and Trichomes in Myrsinaceæ, 189
- Trees, Canker, 652
- Fruits, Ripe, Sugar in, 192
- Frye, T. C., Morphological Study of *Asclepiadaceæ*, 512
- Fuchs, E., Staining of Streptotrichaceæ, 541
- Fuess' Hemispherical Gypsum and Metal Reflectors, 763
- Fulgur, Notes on Species, 32
- Funaria hygrometrica*, Chromosomes, 628
- Fünfstück, M., Research on Lichens, 208
- Fungal Parasites, Persistence in altered Conditions of the Host Plants, 651
- Funghi, Il Trattato dei, 215
- Fungi, Adventitious Growths, 212
- African, 214
- American, 654
- — Notes, 74
- Australian, 655
- Critical Notes, 76
- Decomposition of Lactic Acid, 534
- Destruction of Seeds, 644
- East African, 537
- Extra-European, 215
- Fat-Destroying, of Seeds, 534
- Fossil, 74, 534
- from Galapagos, 214
- Growing, Chemical Action, 651
- hypogæi, 651
- imperfecti: Kryptogamen-Flora, 209
- in Dairy Products, 534
- Japanese, 73
- New Parasitic, 206
- New Records, 655
- Notes on Various, 651
- of *Lomellina*, 214
- of Mount Ventoux, 214
- Fungi of New Caledonia, 535
- of Piedmont, 73
- of the Setubal Region, 73
- Oidium Production and the Culture of the Higher, 75
- Photography, 76
- Poisoning, 212
- Polonici, 535, 654
- Production of Acids, 752
- — of Glycogen, 752
- Rare Sicilian, 535
- Sap of, as Antidote to Venom of Serpents, 76
- Study, 212
- Systematic Notes, 656
- Wood-destroying, 211
- Yeast-forms, 747
- Fungicides, 652
- Fungous Diseases of White Cedar, 75
- Fungus Diseases, 653
- — in Australia, 74
- — in Italy, 213
- Flora, 214
- — of Humus, 74
- — of Piedmont, 535
- — of Sao Paulo, 214
- — of Sonntagberg, 73
- Fürth, O. v., Chemical Physiology of Invertebrates, 598

## G.

- Gadd, G., Food-Canal of Larvæ of Cuckoo-Spit, 174
- Gadean, H., How Birds make themselves understood by Man, 602
- Gage, C. S., Simple Device for Carrying Minute Objects through the Grades Cedar Oil and Paraffin, 230
- Gage, S. H., New Razor-holder and Adjustable Clamp for the Minot Microtome, 234
- Gaidukow, N., Literature on the Algal Flora of Russia, 326
- Galapagos Birds, Mallophaga, 38
- Galaxaura adriatica*, 637
- Galeopithecus volans*, Eating Habits, 30
- Gallein, Staining Nervous Tissue, 559
- Gall-forming Copepod in an Anemone, 300
- Galli-Valero, B., Mosquitos in Winter, 606
- Gamasus auris*, 177
- Gamble, F. W., Bionomics of *Convolvata Roscoffensis*, 725
- Colour-Physiology of Higher Crustacea, 609
- Gamble, J. S., Manual of Indian Timbers, 52
- Gametes, Sex Determination in Hermaphrodite Gonads, 32
- Gametophytes and Embryo of *Taxodium*, 734

- Gamopetalous Flowers, Colours of North-  
 ern, 739  
 Ganglion in *Ciona intestinalis*, Function,  
 489  
 — Sub-Esophageal, of Liver-Fluke, 303  
 Ganoids and Dipnoi, "Larynx," 600  
 Gardiner, J. S., Notes on Variation, Pro-  
 tectory, and Senescence in *Flabellum*,  
 184  
 — Structure and Development of *Flabel-  
 lum*, 184  
 Gardner, N. L., Algæ N.-Western America,  
 527  
 Garotilla, La, 756  
 Garter Snakes, Variations, 601  
 Gasching, E., Researches on the Ferment-  
 ation of Milk, 756  
*Gasterosteus aculeatus*, Resistance to Osmo-  
 tic Pressure of Different Media, 714  
 Gastromycetes, Genera, 73  
 — Spore-formation, 211  
 Gastropod Eye, Retina, 168  
 — Shells, Studies, 290  
 — Studies, 718  
 Gastropods, Demonstrating the Structure  
 368  
 — Follicular Cells in Gonads, 492  
 — Recent Researches, 32  
 — Tracheopulmonate, 291  
 Gastrulation of Double-Development in  
 Trout, 161  
 Gautier, A., Arsenic in Animals, 598  
 — — in Plants and Animals, 186  
 — Fibrinogenic Substance in Albumen of  
 Bird's Egg, 31  
 Gavotti, G., Il Trattato dei Funghi, 215  
 Gecko's Toes, Structure, 712  
 Geheeb, A., Suppression of Redundant  
 Moss-Species, 60  
 Gemelli, E., New Method of Staining  
 Flagella, 235  
 Gêneau de Lamarlière, L., Conifer Wood  
 from the Turf-Pits, 50  
 Genera, New, Anajapyx, 295  
 — — *Arrhinotermes*, 172  
 — — *Atractinium*, 639  
 — — *Axinopocus*, 721  
 — — *Brachiosaurus*, 287  
 — — *Bucegia*, 743  
 — — *Burnettia*, 742  
 — — *Bythotiara*, 304  
 — — *Caryotropha*, 185  
 — — *Cephaliphora*, 529  
 — — *Chionaster*, 631  
 — — *Clathrella*, 305  
 — — *Cænomyces consuens*, 641  
 — — *Cryptogonimus*, 303  
 — — *Cumoniscus*, 178  
 — — *Dichotomosiphon*, 64  
 — — *Dictyosphariopsis*, 630  
 — — *Dimerogonus*, 297  
 — — *Enteroxenos*, 32  
 — — *Eochelone*, 712  
 Genera, New, *Gastrosaccus* (Sars) = *Pro-  
 dajus* (Bonnier), 178  
 — — *Gephyrocirinus*, 43  
 — — *Gephyronema*, 725  
 — — *Goldmannia*, 626  
 — — *Haplosomides*, 297  
 — — *Herpophyllon*, 67  
 — — *Heterocephalum*, 529  
 — — *Heteroplegma*, 536  
 — — *Höhneliella*, 73  
 — — *Hoploderma*, 500  
 — — *Hyalothyridium*, 69  
 — — *Hydropedeticus*, 36  
 — — *Implicaria*, 66  
 — — *Kjellmanniella*, 527  
 — — *Lichtheimia*, 334, 746  
 — — *Limosphenia*, 64  
 — — *Lophyrophorus*, 606  
 — — *Microtermes*, 172  
 — — *Mitruiliopsis*, 536  
 — — *Myosoma*, 727  
 — — *Obesiella*, 497  
 — — *Oligotrema*, 602  
 — — *Ophiogloea*, 536  
 — — *Ophionotus*, 304  
 — — *Ophiosteira*, 303  
 — — *Placoneis*, 744  
 — — *Planctonema*, 630  
 — — *Pleurocoralloides*, 184  
 — — *Proabsidia*, 334, 746  
 — — *Prodajus* (Bonnier) = *Gastrosaccus*  
 (Sars), 178  
 — — *Protascus*, 332  
 — — *Protocleipsis*, 180  
 — — *Psilothecium*, 536  
 — — *Pyropolyporus*, 536  
 — — *Riceoa*, 535  
 — — *Rudicularia*, 202  
 — — *Ruhlandiella*, 334  
 — — *Santiella*, 69  
 — — *Schizobranchium*, 603  
 — — *Scytopezis*, 536  
 — — *Shelfordia*, 182  
 — — *Siphonobius*, 725  
 — — *Solenoplea*, 335  
 — — *Speculitermes*, 172  
 — — *Sporoctomorpha*, 656  
 — — *Sporophlyctis*, 333  
 — — *Stachybotryella*, 537  
 — — *Staurophora*, 744  
 — — *Stephanosalpa*, 490  
 — — *Strasseria*, 73  
 — — *Taphridium*, 331  
 — — *Thamnocladus*, 639  
 — — *Trigonosporium*, 69  
 — — *Uncimenia*, 717  
 — — *Urogonoporus*, 615  
 — — *Wlassicsia*, 716  
 — — *Zygorhynchus*, 746  
 Genital Apparatus of Bats, 711  
 — Male, Appendages in Lepidoptera, 605  
 Gentianaceæ, Development and Structure  
 of Seed-Coat, 622

- Geographical Distribution, 167  
 Geophilus, Myxosporidian Parasite, 618  
 Geotropism, Statolith Theory, 515  
 Gephyrea, Studies, 725  
 Gephyreans, Endothelial Derivatives and Pigment-Bodies, 613  
 Gerlach, —, Nitrogen-Fixing Bacteria, 540  
 Germ-Cells and Germinal Continuity, 22  
 — — in Lepidoptera, Studies on the History, 175  
 Germination and Ripening of Seeds, 315  
 — of certain Floridæ, 351  
 — of Orchids, a Symbiotic Relationship, 737  
 — of Spores of Penicillium, Influence of Substratum, 645  
 — of Teleutospores, 210  
 Gessard, C., Formation of Black Pigment in Tumours of Horse, 488  
 — Oxidising Ferments in Ink of Cuttle-fishes, 490  
 Giant Cells, Origin, 597  
 Giardina, A., Theory of Cell-Division, 26  
 Gifford, J. W., 248  
 Gil, A. C., European Muscineæ, 197  
 Gill-Filters of Freshwater Fishes, 714  
 Gillot, X., Sap of Fungi as an Antidote to the Venom of Serpents, 76  
 Gilson, G., Cricket of Aquatic Habits, 36  
*Ginkgo biloba*, Composition of Seeds, 193  
 Gizzard of Carabidæ, Structure, 296  
 Glage, F., Fusible Metal Stopper for Test-tubes, 240  
 Glaisher, James, 158  
 Glamann, G., Tracheopulmonate Gastropods, 291  
 Gland, Hermaphrodite, of *Limax maximus*, Sexual Differentiation, 718  
 Glands, Brunner's, 709  
 — Digestive, of Monascidæ, 489  
 — Dorsal, of Larvæ of Hemiptera Heteroptera, 294  
 — Odoriferous, of *Julus communis*, 297  
 — Poison, Origin in Land Salamander, 713  
 Glandular Cells, Trophospongia, 596  
 Glaser, O. C., Nematocysts of Nudibranchs, 291  
 Glass for Optical Purposes, 102  
 — Ink for Writing on, 112  
 — Jena, 554  
 Glazebrook, Dr., Glass for Optical Purposes, 102  
 Gleason, R. L., 120  
*Gleditsia triacanthos*, Thorns, 51  
*Gleosporium phomoides*, 208  
 Gluck, H., *Nectria moschata*, 69  
 Glycogen from Yeast, 49  
 — Production in Fungi, 752  
 Gnat Larvæ, Excretion, 173  
 Godfrin, J., Critical Agarics, 532  
 Godman, F. D., Butterflies of Borderland between North and South America, 34  
 Goette, A., Text-Book of Zoology, 166  
 Goggio, E., Development of Lungs in *Discoglossus pictus*, 707  
 Golden, K. E., Histology of the Wood in Species of Pines, 188  
 Goldschmidt, R., Development of Appendicularia, 167  
 — Sense-Organs of *Asearis*, 499  
 Gold-Silver Series of Alloys, Properties, 375  
 Golovine, E., Fixing Neutral Red, 106  
 Gomont, M., New Species of *Fischerella*, 76  
 Gonads and Kidneys, Relations in *Haliotis*, 170  
 — Female, of Lancelet, Structure and Development, 594  
 — of Gastropods, Follicular Cells, 492  
 — of *Hesione sticula*, 613  
*Gonionema murbachii*, Development, 501  
 Gonococcus in the General Circulation, 84  
 Gooseberry Mildew, 69  
 — — in Europe, 335  
 Gordon, J. W., 565, 571  
 — Photomicrographs of *Pleurosigma angulatum*, 780  
 — The Helmholtz Theory of the Microscope, 246, 250, 381  
 Gorgonacea and Pennatulacea, New, 184  
 Goriini, C., Acid-Rennet-forming Bacteria in Milk, 77  
 — Bacteria of the Milk-ducts of the Cow, 83  
 Gosse, —, Microscope used by, 118  
 Gough, L. H., Anomalies on Head-Shields of Snakes, 166  
 Grabau, A., Gastropod Studies, 718  
 Grabau, A. W., Studies of Gastropod Shells, 290  
 — Development of the Biserial Arm in Certain Crinoids, 728  
 Graff, L. v., Notes on *Gyrator hermaphroditus*, 41  
 Grafted Plants, Experiments, 511  
 Grafting, Modification of Habit, 610  
 Grandi, S. de, Observations on the Flagella of the Tetanus Bacillus, 663  
 Grapes, Black-rot, 209  
 Graptolites, Development, 729  
 — Studies, 184  
 Grasses, Diseases, 751  
 Gravier, C., Adult Pelagic Cerianthid, 44  
 — Fresh-water Polychæts, 301  
 — Nervous System of Nautilus, 490  
 Gray, St. G., Screw-Worms in St. Lucia, 293  
 Grayson, H. J., Red Rain, 682  
 Greenish, H. G., Microscopical Examination of Foods and Drugs, 561  
 Greenman, J. M., Monograph of North and Central American Species of *Senecio*, 57

- Gregarine, Cœlomic, in a Beetle, 307  
 Gregarines, Development, 619  
 Grégoire, —, Reconstitution and Formation of Chromosomes in Somatic Nuclei, 505  
 Greig-Smith, R., *Bacillus vascularum* and gummosis, 82  
 — Bacterial Origin of Vegetable Gums, 339  
 — New Ascobacterium from the Sugar-Cane, 82  
 Grélot, P., Laticiferous Tissue in Flowers of Convolvulaceæ, 513  
 Griffin, E., Photosynthesis, 54  
 Griffon, V., Bacillus of Soft Sore, 83  
 Grimme, A., Fertilisation and Spore-Ripening in Mosses, 522  
 Grintzesco, J., Cultivation of *Chlorella vulgaris*, 328  
 — Morphology and Physiology of *Scenedesmus acutus*, 525  
 Groot, J. G. de, Iron Carmalun, 773  
 Gross, J., Optic Chiasma of Reptiles, 285  
 Grout, A. J., American Mosses, 628  
 — Orthotrichum in the United States, 196  
 — Peristome, 60  
 — and Others, N. American Mosses, 524  
 Growth, Influence of Carbonic Acid Gas, 189  
 — Localised Stages, 51  
 Grubbs, S. B., Ring Test for Indol, 366  
 Gruber, T., *Coccus lactis viscosi* and the Causes of Sliminess and Threads in Milk, 216  
 Grünberg, K., Interesting Case of Parasitism, 720  
 — Oogenesis in Lepidoptera, 496  
 — Studies on the History of the Germ-Cells in Lepidoptera, 175  
 Grünblatt, E. N., Differentiation of True and False Diphtheria Bacilli, 366  
 Grünblatt, G. W., Differentiation of the Diphtheria and Pseudo-Diphtheria Bacillus, 343  
 Guéguen, F., Adventitious Growths in Fungi, 212  
 — *Gleosporium pomoides*, 208  
 — *Helminthosporium macrocarpum*, 528  
 Guerin, J., Development and Structure of the Seed-Coat in Gentianaceæ, 622  
 Guignard, L., Double Fertilisation in Crucifers, 53  
 Guillermond, A., Cytology of Yeast, 205  
 Guillermond, M. A., Spore-formation in Yeast, 68  
 Guillermond, A., Cytology of Yeast, 335, 646  
 — Epiplasm of Ascomycetes, 644  
 — Structure of *Botrytis cinerea*, 647  
 Guillermond, M. A., Metachromatic Corpuscles in the Ascomycetes, 751  
 Guitel, F., Specific Differences in the Kidneys of Lepidogaster, 600  
 Gulde, J., Dorsal Glands of Larvæ of Hemiptera-Heteroptera, 294  
 Gum Bacterium, New, 77  
 Gummosis and *Bacillus vascularum*, 82  
 Gums, Resins, and other Vegetable Exudations of Australia, 50  
 — Vegetable, Bacterial Origin, 339  
 Günther, R. T., Cœlentera from Intermediate Waters of North Atlantic, 304  
 — Distribution of Mid-water Chætognatha in N. Atlantic, 725  
 Guttenberg, H. v., Crystal-cells and the Leaf of Citrus, 732  
 Gutwinski, R., Algæ from Central Asia and China, 639  
 — Javan Algæ, 203  
 Gymnoasceæ, Observations, 646  
 Gymnomitrium and Marsupella, 743  
 Gynandromorphism in *Hilara wheeleri*, 36  
*Gyrotator hermaphroditus*, Notes, 41  
 Gyrocotyle, New, 302  
 Gyrodactylus, Behaviour of Chromatin in Segmentation of Ovum, 615
- ## H.
- Hæmatolytic Function of Spleen, 30  
 Hæmatozoa in Marine Fishes, 46  
*Hæmenteria costata*, Phenomena of Fertilisation, 498  
 Hæmogregarines of Ophidia, 307  
 Häcker, V., Parental and Grand-parental Components of the Nucleus, 281  
 Hairs, Distribution on the Surface of the Stem, 52  
 Halbert, J. N., Beetles of Ireland, 176  
 — Irish Fresh-water Mites, 496  
 Haliotis, Relations of Kidneys and Gonads, 170  
 Hall, C. v., St. John's Disease of Peas, 338  
 Hall, J. L., Effect of Superheated Steam upon the Tensile Strength of Alloys, 683  
 Hall, T. S., Occurrence of Monogruptus in New South Wales, 728  
 Halpern, B., Ventral Nerve-Cord of Crayfish, 299  
 Haltica, the Vine-pest, Dipterous Parasite of, 606  
 Hamilton, W. P., British Moss Flora, 61  
 Hamlyn-Harris, R., Apparatus for Facilitating the Manipulation of Celloidin Sections, 238, 377  
 — Statorysts of Cephalopods, 716  
 Handloup, Leitz', 761  
 Hanna, W., Snake Venoms, 30  
 Hangsig, A., Fresh-water Algæ, 326  
 — Protection of Young Foliage Leaves and Seed-Leaves, 51  
 Hansen, E. C., Formation of Yeast Spores, 336  
 — Life-History of Yeasts, 205

- Hausen, H. J., Anuropus and Bathynomus, 611  
 — New Species of Sergestes, 497  
 Harden, A., Biological Method for Resolving Inactive Acids into their Optically Active Components, 533  
 — Glycogen from Yeast, 49  
 Hargitt, C. W., North American Scyphomedusæ, 617  
 Hariot, P., Fungi from New Caledonia, 535  
 Harpidia, European, 195  
 Harris, C. W., Umbilicaria in North America, 71  
 Harris, D. L., Rapid Method of Hardening and Imbedding Tissues, 768  
 Harris, H. F., Modification of the Romanowsky Stain, 680  
 Harris, J. A., Habits of Cambarus, 723  
 — Thorns of *Gleditschia triacanthos*, 51  
 Harris, W. H., Teeth of Diptera, 606  
 Harrison, F. C., New Bacterium in Freshly-drawn Milk, 343  
 Harrison, H. S., Homology of the Lagena throughout Vertebrates, 710  
 Harshberger, J. W., Fungous Diseases of White Cedar, 75  
 — Strand Flora of New Jersey, 193  
 Hartig, R., Dry-rot and other Wood-destroying Fungi, 211  
 Hartmeyer, R., Arctic Variety of *Ciona intestinalis*, 602  
 Hasslauer, —, Bacterial Flora of the Nose, 340  
 Haswell, W. A., New Gyrocotyle, 302  
 — Two Remarkable Sporocysts from *Mytilus latus*, 726  
 Hatai, S., Intercapular Gland in Human Embryo, 29  
 Hatcher, J. B., Ancestral Canidæ, 711  
 Hausemann, V., Acid-fast Bacilli in *Python reticularis*, 660  
 Haynes, C. C., American Hepatics, 322  
 Hazen, T. E., Ulotrichaceæ and Chætophoraceæ of the United States, 65  
 Head-Shields of Snakes, Anomalies, 166  
 Hearing, Sense of, in Fishes, 713  
 Heart of Enteropneusta, 42  
 Heath, H., Function of Subradular Organ in Chiton, 492  
 Hebb, Dr. R. G., 122  
 Hébert, A., Nutrition of Chrysanthemums, 737  
 Heiden, H., Fossil Diatoms, 635  
 Heidenhain, M., Molecular Structure and Histology, 25  
 Heinricher, E., Influence of Light on Seed-Germination, 55  
 Heinze, B., Production of Acids by Fungi, 752  
*Helenium autumnale*, Abnormal Flowers, 623  
 Heliostat, Dr. G. Johnstone Stoney's Improved, 92  
*Helix pomatia*, Kidney, 290  
 Helmholtz, Hermann Ludwig Ferdinand von, 245  
 — Theory of the Microscope, 381  
 Helminthosporium and Pleospora, Relationship, 747  
*Helminthosporium macrocarpum*, 528  
 Hemicleipsis and Allied Genera, 180  
 Hemimerus, Systematic Position, 607  
 Hemiptera-Hymenoptera, Dorsal Glands of Larvæ, 294  
 Hemp and Flax, Retting, 661  
 Hemsley, —, Chinese Flora, 193  
 Henckel, A., *Cystodinium purpurascens* and *Chordaria flagelliformis*, 527  
 Henneberg, W., Research on Amylomyces  $\beta$ , 204  
 — and Others, Yeast Forms, &c., 646  
 Henning, F., Volatilisation and Recrystallisation of the Platinum Metals, 115 j  
 Hennings, C., Marine Myriopods, 722  
 Hennings, P., African Fungi, 214, 537  
 — Australian Fungi, 655  
 — Distribution of Plant Diseases, 207  
 — Fungus Flora of Sao Paulo, 214  
 — Japanese Fungi, 73  
 — Microthamium, 197  
 — New Discomycetes, 334  
 — New Member of the Phalloideæ, 73  
 — Persistence of Fungal Parasites in altered Conditions of the Host Plants, 651  
 — *Ruhlandiella berolinensis*, 334  
 Hepatic Function in Insects, 173  
 Hepaticæ, Biology, 629  
 — British, 198, 742  
 — European, 198, 742  
 — of Puerto Rico, 323  
 Hepatics, American, 322  
 — and Sphagna, German, 322  
 — British, 59  
 — Culture, 321  
 — Irish, 523  
 — Italian, 322  
 — New Zealand, 59  
 — North American, 59, 743  
 — of Baden, 59  
 — Papillate, 322  
 Heredity, Mendelian, 706  
 — Study, 335  
 Hériveau, F., Fossil Diatoms of Auvergne, 525  
 Hériveau, J., Diatoms of Auvergne, 634  
 Hermaphrodite Gland of *Limax maximus*, Sexual Differentiation, 718  
 Hermaphroditism in Fishes, 282  
 Hermit-Crab, Nuclear Changes in Secretion of Hepato-Pancreatic Cells, 178  
 Hermit-Crabs, New Parasite, 730  
 Herrick, C. J., Size of Nerve-Fibres in Fishes, 284  
 Herring, Pickled, Autolytic Processes, 31

- Hertwig, O., Treatise on Comparative and Experimental Embryology, 483  
 — — of Vertebrates, 160  
 Hérubel, M. A., Distribution and Affinities of Sipunculids, 612  
 — Endothelial Derivatives and Pigment-Bodies in Gephyreans, 613  
 — Notes on Sipunculids, 613  
 Herzog, R. O., Photosynthesis, 55  
 Herzog, T., European Mosses, 323  
*Hesione sicula*, Gonads, 613  
 Hesse, R., Retina of Gastropod Eye, 168  
*Hetrotenthis weberi*, 716  
 Hexacorallia, Peculiar Structure, 502  
 Hexactinellids, Studies, 502  
 Heydrich, F., Melobesiae, 202  
 — New Genus of Delesseriaceae, 66  
 — — of Valoniaceae, 201  
 — — Rhododermis, 636  
 Heyl, G., Alkaloids of *Dicentra formosa*, 732  
 Hibernation of Ants, 719  
 High Powers, New Arrangement for avoiding Injury when Focussing, 220  
*Hilara wheeleri*, Gynandromorphism, 36  
 Hill, H., *Cordiceps Robertsii*, 69  
 Hill, J. A., Method of Mounting Bacteria from fluid Media, 561  
 Hill, J. P., Early Stages in Development of Ornithorhynchus, 282  
 Hilleshel, C., Nuclear Stains for Fresh-water Algæ, 630  
 Himmel, J., Use of Neutral Red in the Study of Phagocytosis, &c., 78  
 Hind-End of Ascaris, 180  
 Hind-Gut and Mid-Gut, Connection between, in Larval Hymenoptera, 720  
 Hinterberger, A., Thermophore for use in Staining, 774  
 Hiuze, J., *Thiophysa volutans*, 754  
 Hiorns, A. H., Metallography: An Introduction to the Study of the Structure of the Metals chiefly by the Aid of the Microscope, 114  
*Hippobosca tasmanica*, 294  
 Hirschbruch, A., Sprouting of Yeast Cells, 68  
 — Yeast, 205  
 Histology, Comparative, Text-Book, 26  
 Hophreutiner, B. P. G., Biology of Fruit in Malvaceae, 313  
 Holborn, L., Volatilisation and Recrystallisation of the Platinum Metals, 115  
 Holler, A., European Hepaticæ, 198  
 Hollös, L., Species of Discisceda, 532  
 Holbrung, M., Jahresbericht der Pflanzenkrankheiten, 534  
 Holmes, F. J., Death-Feigning in Terrestrial Amphipods, 723  
 Holmes, S. J., North American Amphipods, 723  
 — Phototaxis in Volvox, 730  
 Holmgren, E., Intracellular Threads in Nerve-Cells, 596  
 — Trophospongia, 162  
 — — in Glandular Cells, 596  
 — Trophospongium of Nerve-Cells and Pancreatic Cells, 26  
 Holmgren, N., Excretory Processes in Insects, 34  
 — Morphological Significance of Chitinous Cuticle, 33  
 Holothuroid, Abyssal, *Entosiphon Deimatis* Parasitic in, 491  
 Holtz, F. L., *Pelvetia fastigiata*, 636  
 Holtz, L., Characeae of Mark Brandenburg, 202  
 Holway, E. W. D., and Others, Notes on Uredineae, 530  
 Holzinger, J. M., Biology of K. G. Limpricht, 325  
 — Inconspicuous Mosses, 325  
 — Mosses of Alaska, 325  
*Homalia lusitanica*, 523  
 Hone, D. S., *Petalonema alatum*, 658  
 Hooke, Interesting Extract from, 110  
 Hooker, Sir J., New Micrometer, 112  
 Horder, E., Metal Clinical Case, 782  
 Horuiker, E., Staining the Plague Bacillus, 108  
 Horrell, E. C., Sphagna of Upper Teesdale, 523  
 Horse Disease, Central South American, Parasite of, 619  
 — Formation of Black Pigment in Tumours, 488  
 — Origin of Thoroughbred, 711  
 Horses in Philippines, Trypanosomiasis, 619  
 Horseshoe Stage, An Improved, 591  
 Host, Intermediate, of *Filaria immitis*, 40  
 Hot Stage, New Regulating Arrangement, 669  
 Houghton, H. S., Development of Musculature and Skeleton in *Spelerpes longicaudus*, 595  
 Houstad, H., Jena Glass and its Scientific and Industrial Appliances, 554  
 Houssay, F., Carnivorous Fowls of the Second Generation, 282  
 — Modifications Observed in Carnivorous Fowls, 286  
 — Organic Sexual Dimorphism in Fowls, 160  
 Howard, A. D., Structure of the Outer Segments of the Rods in the Retina of Vertebrates, 710  
 Howe, M. A., *Caloglossa Leprieurii*, 66  
 — Riella, 522  
 Huber, T., Amazon Flora, 626  
 Hübner, J., Microscopical Examination of Paper, 774  
 Hudsonite, Amphibole, previously called a Pyroxene, Note, 777

- Humphrey, J. C. W., Fracture of Metals under repeated Alternations of Stress, 115
- Humus Fungus Flora, 74
- Hunter, J., Eye-piece Lens Interval as arranged for Achromatism, 221
- Husband, M. A., Notes on Cladonias, 538
- Husek, G. Starch-Grains in the Root-Cap of the Onion, 508
- Hyaella, Marine Species, 178
- Hyalospora Aspidiolum*, 210
- Hyams, J., Chemical Composition of *Oscillaria prolifica*, 76
- Hybrid Nature of *Triton blasii*, 707
- Hybrids, Determination of Dominance in the Colour Characters, 519
- On the Characters, 739
- Plant, Behaviour of Nuclei, 506
- Hydated Cysts, Production from Soolices, 42
- Hydnangeum carneum*, Nuclear behaviour and Spore-Formation, 750
- Hydra and Aurelia, Spermatogenesis, 304
- Method for Demonstrating Nematocyst Cells, 237
- Hydrachnid Larvæ Living in Trout's Stomach, 609
- Hydrachnidæ and Ixodidæ from South America, 298
- Hydrocyanic Acid in Sorghum, 517
- Hydrogen and Carburetted Hydrogen formed by Plants, 516
- Hydroids, Excretory Cells, 616
- of Pacific Coast of North America, 44, 502
- Hydrolysis of Polysaccharides, 517
- Hymenoptera and Lepidoptera Antennary Sense-Organs, 294
- Larval, Connection between Mid-Gut and Hind-Gut, 720
- Hyphomycetes, New, 529
- Hypomyces, New, 207
- I.
- Ibbotson, F., Analysis of Steel-Works Materials, 375
- Ihering, H. v., Parasitic Worms as Aids in Zoogeographical Investigation, 40
- Ijima, I., Studies on Hexastinellids, 502
- Ikeno, S., Formation of Antherozoids in Marchantia, 321
- Systematic Position of *Monascus purpureus*, 746
- Ikeno, —., Development of Spermatozoids in Marchantia, 741
- Illingworth, J. F., Structure of *Lucapina crenulata*, 169
- Illuminating Apparatus for Metallography, 97
- Illuminating Cones, Wide, 673
- Illumination and the Use of Condenser in Histological Micrography, 97
- Illuminator, Watson and Sons' Macro-, 91
- Imaginal and Pupal Organs, Precocious Development in Caterpillars, 605
- Imagines, Changes in, induced by Change of Diet in Caterpillars, 294
- Imbedding and Fixing Dense Connective Tissue, 369
- and Hardening Tissues, Rapid Method, 768
- in Celloidin, 770
- in Paraffin, New Methods, 369
- Medium, New, 558
- Small Objects, New Method, 233
- Immersion Oil Bottle, 777
- Index Animum, 598
- Ocular, Bourquet's New, 91
- Indol, Ring Test, 366
- Inertia, Functional, of Plant Protoplasm, 191
- Infection Experiments with Claviceps, 746
- Infusorians, Fossil, 306
- Marine Adaptability to Fresh Water, 306
- Senescence and Conjugation, 503
- Inga, Seeds, 513
- Ingham, W., British Moss Flora, 61
- Yorkshire Muscinæ, 323
- Injections, Physiological, Notes, 285
- Ink for Writing on Glass, 112
- Innervation of Mantle of Pecten, 33
- of Metacephalic Segment, 34
- Insect, A Most Primitive, 295
- against Insect, 294
- Visitors and Poppies, 518
- and Flowers, 604
- and Myriopods, Joints of the Walking Legs, 604
- and Petal-less Flowers, 604
- Excretory Processes, 34
- Exuvial Glands, 173
- Hepatic Function, 173
- Metamorphosis of Nervous System, 604
- Mouth-parts, 34
- of the Drift Line, 33
- Preparing Serial Sections, 106
- Insects and Floral Colours, 718
- Aquatic, of New York State, 722
- Integumentary Organs of Cervidæ, 284
- Intercellular Connections, 487
- Interseapular Gland in Human Embryos, 29
- Intestinal Villi, Structure, 164
- Intestine, Human, Beetle Embedded in Wall, 720
- Post-embryonic Development, 493
- “Intracellular Threads” in Ganglion-Cells of Electric Organ of Torpedo, 162
- Intranuclear Space in Liver Cells, 162
- Invertebrates, Chemical Physiology, 598
- Ionisation, Relations to Plant-Growth, 56

- Irgang, G., Sap-excreting Elements in *Tropæolum majus*, 733  
 Iron Carmalum, 773  
 Isert, A., Digestive Glands of Monacidae, 489  
*Isistius brasiliensis*, Brain, 289  
 Isolating *Bacillus icteroides*, New Method, 767  
 Isopod, Statocysts in, 610  
 Isopods, Terrestrial, Absorption and Secretion, 39  
 Issatchenko, M. B., Experiments with Bacterial Light, 662  
 Iterson, G. v. jr., Accumulation Experiments with Denitrifying Bacteria, 539  
 Ives, F. E., New Binocular Microscope, 85  
 — Stereoscopic Photomicrography, 223  
 Iwanhow, W. W., Leprosy Bacillus, 218  
 Iwanowski, —, Development of Yeast in Sugar Solution without Fermentation, 337  
 Ixodidae and Hydrachnida, New, from S. America, 298  
 — Species, 496  
 Iznka, A., Observations on the Jananese Palolo (*Ceratocephale osawai* sp. n.), 724
- J.
- Jaccard, P., Floral Distribution in the Alpine Zone, 57  
 Jackson, C. M., Morphology of the Myxinooids, 487  
 Jackson, D. D., Genus *Crenothrix*, 215  
 Jacky, E., Experiments with Pucciniæ, 648  
*Jacquinia ruscifolia*, Fruit, and Trichomes in Myrsinaceæ, 189  
 Jaczewski, A. v., Disease of *Sorbus Aucuparia*, 335  
 — St. John's Disease of Peas, 338  
 Jaeger, H., Characters of *Meningococcus intracellularis*, 343  
 Jameson, H. L., Formation of Pearls, 170  
 Janicki, C. v., Behaviour of Chromatin in Segmentation of Ovum of Gyrodactylus, 615  
 Jatta, A., Chinese Lichens, 208  
 — and Others, Lichens, 657  
 Javillier, M., Proteolytic Ferments, 625  
 Jena Glass, 554  
 Jobert, —, Muscular Apparatus of Anomia, 171  
 Jochmann, G., Rapid Diagnosis of Typhus Bacilli, 343  
 Joesting, F., Anatomy of Certain Groups of Caryophyllaceæ, 510  
 Johnson, D. S., Development in Piperaceæ, 511  
 Johnson, L., 249  
 Johnson, T., Fungicides, 652  
 Johnson, W. B., Gonococcus in the General Circulation, 81  
 Johnson, W. F., Beetles of Ireland, 176  
 Johnston, J. R., *Cauloglossum transversarium*, 532  
 Johnston, S. J., New Distomum from Sawfish Shark, 500  
 Joints of the Walking Legs in Insects and Myriopods, 684  
 Joly, J., Improved Method of Identifying Crystals in Rock Sections by use of Birefringence, and Improved Polarising Vertical Illuminator, 683  
 Jones, C. P., Streptothrix, 215  
 Jonsson, H., Marine Algae of Iceland, 528  
 Jordan, D. S., Colours of Fishes, 28  
 Jordan, H., Function of Mid-Gut Gland of Crayfish, 178  
 Joubin, L., *Hetroteuthis weberi*, 716  
 — *Loligo media*, 716  
 Jourdain, L., New Cuttle-fishes, 168  
 Juel, H. O., Development of *Dipodascus albidus*, 69  
 — Development of the Ovule in Casuarina, 736  
 Juglandæ, Floral Structure, 314  
*Julus communis*, Odoriferous Glands, 297  
 Juncaceæ, Formation of Egg and Division of Antipodal Cell, 736  
 Jung, —, New Student's Microtome, 230  
 Jung, R., Apparatus for the Quick and Uniform Staining of Serial Sections and for the Treatment of them in Number with Reagents, 679  
 Jurie, A., Morphological variation in Leaves of the Vine as a consequence of Grafting, 738
- K.
- Kayser, —, Paratyphoid Fever, 344  
 Keeble, F., Bionomics of *Convoluta Roscoffensis*, 725  
 — Colour-Physiology of Higher Crustacea, 609  
 Keeley, F. J., Preparation of Diatoms, 768  
 Keissler, C. v., Plankton of the Alt-Ausseer Lake, 199  
 Keller, R., Mosses of Central Switzerland, 199  
 Kellerman, K., Method of Making Colodion Tubes, 112  
 Kellerman, K. F., Effects of Chemical Agents on the Starch-converting Power of Taka Diastase, 517  
 Kellog, V. L., Larva of Giant Crane Fly, 36  
 — Mallophaga from Galapagos Birds, 38  
 — Mouth-parts of Insects, 34  
 — Net-winged Midges, 292  
 Kelly, B. E., Application of the Cinematograph Principle to the Study of Serial Sections, 776



- Kennedy, C., Unilateral Coloration with Bilateral Effect, 601  
 Kerforne, E., Development of Graptolites, 729  
 Kidney of *Helix pomatia*, 290  
 Kidneys and Gonads, Relations in Haliotis, 170  
 — Functional Inequality, 488  
 — of Lepadogaster, Specific Differences of, 600  
 Kime, J. W., Some Experiments with Actinic Light, 766  
 Kinase, Presence in Basidiomycetes, 533  
 Kindberg, N. C., *Anomodon Toccoæ*, 623  
 — Genus *Thamnum*, 60  
 — N. American Mosses, 324  
 — *Thamnum*, 742  
 Kindborg, A., Pneumococcus which liquefies Gelatin, 343  
 Kirkaldy, G. W., Note on Phototropism of *Daphnia*, 497  
 Kishinouye, K., Species of *Corallium*, 616  
 Klebahn, H., Study of Related Forms, 207  
 Klein, E., Agglutination by Blood of Emulsions of Microbes, 756  
 — Method of Detecting the Presence of *Bacillus coli communis* in Shellfish, 229  
 — New Pathogenic Microbe of Diphtheria *Bacillus* Group, 343  
 Klein's Yeast, Research, 647  
 Klemperer, F., Identity of Rhinoscleroma *Bacillus* with Friedländer's *Bacillus*, 80  
 Klunzinger, C. B., *Ptychodera erythræ*, from the Red Sea, 183  
 Koehler, R., *Entosiphon Deimatis* Parasitic in an Abyssal Holothuroid, 491  
 — New Crinoid, 43  
 Kœnenia, New Species, 609  
 Koenigsberger's Microphotometer for the Measurement of Light Absorption, 362  
 Koeppl, E., Genus *Amphion*, 39  
 Köhler, A., Formation of Chorion in *Ptyrhocoris apterus*, 607  
 Kolbe, H., Precocious Development of Pupal and Imaginal Organs in Caterpillars, 605  
 Kolkwitz, R., *Leptomitus lacteus*, 640  
 Kolmer, W., Simple Method of Making Thin Paraffin Sections, 105  
 Koltzoff, N. K., Formative Elastic Structures in Cells, 709  
 Koning, C. J., Fungus Flora of Humus, 74  
 Koninski, K., Biology of Anaerobic Bacteria, 340  
 Kopsch, F., Artificial Fertilisation of the Ova of *Cristiceps argentatus*, 593  
 Korff, K. V., Spermatogenesis in *phalangista vulpina*, 24  
 Koristka's Abbe Camera Lucida with Lens-Holder, 554  
 — Apparatus for the Microscopic Projection of Liquid Preparations, 553  
 Koristka's Hand Magnifiers, 548  
 — Large Reflecting Mirror, 349  
 — Mechanical Stage, 547  
 — Simplified Vertical Camera, 355  
 Kotte, E., Integumentary Sense-Organs of Deep-Sea Decapods, 299  
 Kovarzik, K., Epidemic of Guinea-pigs caused by a Variety of *Bacterium coli*, 342  
 Kowalevsky, A., Phenomena of Fertilisation in *Hæmenteria costata*, 498  
 Kozłowski, B., Staining and Mounting Urinary Sediment, 560  
 Kraemer, H., Continuity of Protoplasm, 47  
 — Structure of Starch-Grain, 507  
 Kraus, R., New Regulating Arrangement for a Hot Stage, 669  
 Krause, F., Differentiation of *Bacillus typhi abdominalis* and *Bacillus coli communis*, 80  
 Krempf, A., Peculiar Structure in Certain Hexacorallia, 502  
 Krieger, —, Catharinea, 523  
 Kries, J. V., Visual Purple, 766  
 Kryptogamen-Flora: Fungi imperfecti, 209, 535  
 Kuckuck, P., Reproduction of *Valonia*, 64  
 Kukenthal, W., Revision of the Nephthyidæ, 728  
 Künkel, K., Breeding Experiments with Sinistral Snails, 603  
 — Locomotion of Slugs, 490  
 Kurjuweit, —, Effect of Oil on Bacteria, 340  
 Kusano, S., Parasitism of *Buckleya Quadriala*, 51  
 Küster, E., Pathological Plant-Anatomy, 621  
 Kuwana, S. I., Mallophaga from Galapagos Birds, 38

## L.

- Laaser, P., Development of Teeth in Selachians, 486  
 Labbé, A., Fibrillar Continuity of Epithelial Cells and Muscles in *Nebalia*, 38  
 Labbé, H., New Protein from Maize, 49  
 Laboratory Methods, Biological, 240  
 Laboulbeniaceæ, 70  
 Labyrinth of Ear of Pig, Circulation, 711  
 Lacertilia, Mastication Muscles, 712  
 Lactic Acid, Decomposition by Fungi, 534  
 Lafar, Dr. F., Technical Mycology, 538  
 "Lag" in Microscopic Vision, 583  
 Lagarde, J., Fungi of Mount Ventoux, 214  
 Lagena, Homology throughout Vertebrates, 710  
*Lagenostoma Lomaxi*, the Seed of *Lyginodendron*, 622  
 Lagochilus, 52

- Laing, R. M., New Zealand Marine Algæ, 68
- Lamarlière, Gêneau de L., Moss Flora of French Caverns, 61
- Lambliia intestinalis* Fatal to Rabbits, 46
- Lambotte, V., Microbe of the "Loque" Disease of Bees, 77
- Laminariaceæ and Laminaria Industries of Hokkaido, Japan, 527
- Studies on the Comparative Development, 526
- Lamp, Electric Incandescent, 97
- New Electrical Microscope, 350
- 90° Automatic Focussing Electric Arc, 97
- — Hand-fed Electric Arc, 98
- Watson and Sons' Incandescent Gas, 92
- Watson's New Standard Electric, 95
- Lamson-Scribner, F., Diseases of Grasses, 751
- Lancelet, Structure and Development of Female Gonads, 594
- Land, W. G., Morphological Study of Thuja, 189
- Landolphias, Caoutchouc-yielding, of the French Congo, 49
- Lange, E. F., Simultaneous Presence of Ferrite and Cementite in Steel, 633
- Lanzi, M., Diatoms of Lake Cotronia, 200
- Fossil Diatoms in Rome, 200
- Il Trattato dei Funghi, 215
- Italian Agaricacæ, 212
- Value of Spore Characters, 212
- Lapicque, L., Hæmatolytic Function of Spleen, 30
- Laponge, G. de, Phylogeny of Carabus, 493
- "Larynx" of Ganoids and Dipnoi, 600
- Laticiferous Tissue in Flowers of Convolvulaceæ, 513
- Launoy, L., Formation of Zymogen in Gastric Glands of Adder, 27
- Nucleolar Changes in Secretion of Hepato-Pancreatic Cells of Hermit-Crab, 178
- Laurent, E., Production of Glycogen in Fungi, 752
- Synthesis of Proteids by Plants, 513
- laurent, M., Formation of the Egg and Division of an Antipodal Cell in the Juncaceæ, 736
- Lauterborn, L., Tracheal Gills on Legs of Larval Perlid, 607
- Larva of Giant Crane Fly, 36
- Laveran, A., Hæmatozoa in Marine Fishes, 46
- Hæmogregarines of Ophidia, 307
- Parasites of an Asiatic Tortoise, 46
- Trypanosomas from Transvaal Cattle, 46
- Lawson, A. A., Relationship of the Nuclear Membrane to the Protoplast, 506
- Studies in Spindle Formation, 731
- Lea, A. M., Tasmanian Phasmid, 721
- Leaf-cells of Sphagnum, 197
- Leaf-Cuticle, Manipulation of Sections, 770
- Leaf-Venation and Chemical Constituents of Eucalypts, 50
- Leaves, Effects of Water and Aqueous Solutions on, 315
- of the Vine, Morphological Variation as a consequence of Grafting, 738
- Leavitt, R. G., Root-Development in Azolla, 520
- Leche, W., Phylogeny of Erinaceidæ, 167
- Lee, A. B., Illumination and the Use of the Condenser in Histological Micrography, 97
- Leech, Alimentary Tract, 302
- Minute Structure of Alimentary Canal, 612
- Lefevre, G., New Method of Imbedding Small Objects, 233
- Leger, L., Development of Gregarines, 619
- Léger, L., New Parasite of Hermit-Crabs, 730
- Parasitic Bacteria in Intestine of Chironomus Larvæ, 294
- Sexual Reproduction of Pteroccephalus, 729
- Legros, R., Vascular System of Amphioxus, 489
- Leguminosæ, Mexican, 626
- Rusts, 531
- Leguminous Plants, Root Tubercles, 217
- Leiss, C., New Crystal Refractometer for the Determination of the Refractive Index of Large and Microscopically Small Objects, 226
- Leitz' Handloupes, 761
- Mineralogical Stand, No. I., 758
- — — No. II., 758
- New Stand and Fine Adjustment, 665
- Lejeunea in North America, 322
- Lemmermann, E., Anabæna, 658
- Lendenfeld, R. v., Note on *Spongilla fragilis*, 502
- Lenhossék, M. v., Development of Corpus Vitreum, 283
- Lens, Pseudoscope, 762
- Lenses, Natural, Photography by, 764
- Photographic, 677
- Lentinus lepidius*, 73
- Leon, N., *Prophysema hæckelii*, 617
- Lepadogaster, Specific Differences in Kidneys, 600
- Lepeschkin, W. W., Study of Heredity, 335
- Lepidoderma, 344
- Lepidoptera and Hymenoptera, Antennary Sense-Organs, 294
- Calorimetric Measurements in Reference to Pupæ, 33
- Evolution of Colour-Patterns, 291
- Larval, Mandibular Glands, 495
- Male Genital Appendages, 605

- Lepidoptera of North America, 495  
 — Oogenesis, 496  
 — Position of Repose, 719  
 — Studies on the History of the Germ-Cells, 175
- Lepidosteus, Early Development, 708
- Leprosy Bacillus, 218
- Leprous Affection of Skin and Lymph-Glands of Sewer Rats, 342
- Leptomitus lacteus*, 640
- Leptothrix racemosa*, 75
- Lerat, P., Maturation-Phenomena in Oogenesis and Spermatogenesis of *Cyclops strenuus*, 39
- Lesage, P., Influence of Substratum on Germination of Spores of *Penicillium*, 645
- Lesions Artificially Induced in the Mother, Reappearance in Offspring, 22
- Le Sourd, —, Bacillus of Soft Sore, 83
- Letellier, A., Purple of *Purpura lapillus*, 290
- Lett, H. W., British Hepatics, 59
- Leucocytes of Man and Monkey, Non-Existence of "Neutrophil" Granules, 468
- Levrat, D., Colour of Silk, 35
- Levy, E., Streptotrichaceæ, 216
- Lewin, M., Development of Beak of Penguin, 283
- Lichen Flora, 209, 753  
 — — New French, 70  
 — — of Algiers, 71  
 — — of the Tyrol, 70  
 — Rare, from Liguria, 70
- Lichens, 657  
 — Brazilian, 753  
 — Californian, 71  
 — Chinese, 208  
 — from Galapagos, 209  
 — Morphology, 753  
 — Products of Metabolism, 537  
 — Research, 208  
 — Two Marine, 537
- Liemosphenia: a New Genus of Diatoms, 64
- Liénard, E., Reserve Carbohydrates of the Albumen of Palms, 49
- Light, Actinic, Experiments with, 766  
 — and Darkness, Influence on Plant-life, 316  
 — Influence on Amœbæ and their Cysts, 617  
 — — on Seed-Germination, 55  
 — Small Electric, for Photomicrography, 95
- Lilley, G., *Nitella batrachosperma*, 631
- Limax maximus*, Sexual Differentiation in Hermaphrodite Gland, 718
- Limb-holder, New Double-hinged, 545
- Limb-Origin, Biometric Evidence bearing on Theory of, 24
- Limbs in Amphibians, Influence of Central Nervous System on Development, 594  
 — Vertebrate, Evolution, 708
- Lime, Carbonate, Utilisation by Anodonta, 718  
 — in Phanerogamic Parasites, 192
- Limestones, Chemical Composition, Microscopical Methods, 681
- Limicolæ, Regeneration, 179
- Limpet, Memoir, 491
- Limpmann, E. O. v., Nomenclature of Enzymes, 517
- Limpricht, K. G., 325
- Limpricht, W., European Mosses, 198, 741
- Lindon, M. G. v., Sensory Hairs on Pupa of *Papilio podalirius*, 175
- Lindroth, J. L. and Others, Rusts of Special Natural Orders, 649
- Linhart, G., Distribution of Plant Diseases, 207
- Linstow, O. v., *Echinococcus alveolaris*, 181
- Liparids, Notes, 176
- Lisianthus, Revision of the Species, 57
- Lister, J. J., Notes on Liparids, 176
- Lithobius forficatus*, Variation, 608
- Little, E. O., Method for Demonstrating Nematocyst Cells in Hydra, 237  
 — Preparing Sections of Cancellous Bone, 769
- Livanow, N., Hemiclepsis and allied Genera, 180
- Liver-Cells, Intranuclear Space, 162
- Liver-Fluke, Sub-œsophageal Ganglion, 303
- Liver in Invertebrates, Adipogenic Function, 31  
 — Relation between Weight and Total Surface, 599
- Lizards, Femoral Glands, 27
- Lloyd, C. G., Genera of Gastromycetes, 73  
 — Notes on American Fungi, 74
- Loading, Influence on the Formation of Wood and Bast Elements in Weeping Trees, 192
- Lobster Larvæ, Emergence, 723
- Locomotion of Slugs, 490
- Locustidæ, Spermatogenesis, 37
- Loeb, J., Experiments on Ova of Starfish, 501
- Loeske, L., German Mosses, 324
- Loew, O., Action of Uranium on Plants, 518
- Loisel, G., Senescence and Conjugation in Infusorians, 503  
 — Spermatogenesis in Sparrow, 23
- Loligo media*, 716
- Lolium temulentum*, Seed-Fungus, 75
- Long, W. H., jun., Ravenelas of the United States and Mexico, 530
- Longmuir, P., Micrographic Study of Cast Iron, 777
- Lönnerberg, E., Adaptations to Molluscivorous Diet in *Varanus niloticus*, 712  
 — Intermediate Form between *Mysis oculata* and *Mysis relicta*, 611

- Looss, A., Trematodes from Marine Turtles, 41  
 "Loque" Disease of Bees, Microbe, 77  
 Lorch, W., Leaf-cells of Sphagnum, 197  
 Lorrain-Smith, A., British Microfungi, 751  
 Lovell, J. H., Colours of Northern Gamopetalous Flowers, 739  
 — Insects and Floral Colours, 718  
 Low, G. C., *Filaria perstans*, 302  
 Lowe, E. E., Insects and Flowers, 604  
 Löwenstein, A., *Mastigocladus laminosus*, 657  
 Loyez, M., Follicular Epithelium in Birds, 594  
 Lubosch, W., Maturation in Newt's Ova and in General, 281  
*Lucapina crenulata*, Structure, 169  
 Lucet, —, *Sterigmatocystis pseudonigra*, 338  
 Luerssen, C., German Pteridophyta, 521  
 Lühe, M., Peculiar Cestode from *Acanthias*, 615  
 — Progress in Study of Coccidia, 730  
 Lumière's Arrangement for taking Photographs in Colours, 118, 119  
 Luminous Bacteria, 756  
 Lung, Vertebrate, Development, 25  
 Lungs, Development in *Discoglossus pictus*, 707  
 Lupins, Uromyces, 650  
 Lütkenmüller, J., Cell-Membrane of Desmidiaceæ, 65, 328  
 Lutz, L., Alkaloids as a Source of Nitrogen, 737  
 — Poisoning by Fungi, 212  
 Lyginodendron, *Lagenostoma Lomari*, the Seed of, 622  
 Lysiannassids, Abyssal, 611
- M.
- McAlpine, Dr., Fungus Diseases in Australia, 74  
 McAlpine, D., Australian Fungi, 655  
 — Black Spot of the Apple, 71  
*Macaranga triloba*, Myrmecophily, 625  
 McArdle, D., and Another, Irish Hepatics, 523  
 Macchiati, L., Photosynthesis Outside the Plant, 314  
 McClung, C. E., Spermatogenesis of Locustidæ, 37  
 MacCullum, W. G., New Monostome from Snapping Turtle, 615  
 Macdougall, D. T., Influence of Light and Darkness on Plant-life, 316  
 Macfadyen, A., Immunising Effects of Contents of Typhoid Bacillus, 541  
 — Intracellular Toxin of the Typhoid Bacillus, 217  
 — Luminous Bacteria, 756  
 Machilis, Compound Eyes, 608  
 M'Intosh, W. C., Abnormal Coloration in Pleuronectids, 166  
 — Frequency of Occurrence of Pearls, 493  
 McKenzie, A., Biological Method for Resolving Inactive Acids into their Optically Active Components, 533  
 Maclaren, N., Skin of Trematodes, 500  
 MacMunn, C. A., Counting the Red Corpuscles of the Blood, 240  
*Macrocytis pyriferæ*, 329  
 Macrosporangia of Selaginella, Opening Mechanism, 321  
 Macrosporangium of Yucca Development, 312  
 Macvicar, S. M., British Hepaticæ, 198  
 Madreporaria, Significance of Budding and Fission, 45  
 Magnaghi, A., Fungi of Lomellina, 214  
 — Fungus Flora, 214  
 Magnifier, Barbour's Pocket, 91  
 Magnifiers, Koristka's Hand, 548  
 Magnoliaceæ, Comparative Anatomy of Stem, 51  
 Magnus, O., Changes Produced in the Peridial Cell-Walls of the Uredineæ, 749  
 Magnus, P., Function of Ganglion in *Ciona intestinalis*, 489  
 — Gooseberry Mildew, 69  
 — *Hyalospora Aspidiotus*, 210  
 — Nomenclature of Uredineæ, 650  
 — *Uredo histortarum*, 210  
 — *Urophlyctis bohémica*, 204  
 Mahen, J., Moss Flora of French Caverns, 61  
 Mahon, J. J., The Microscope in Crucible Steel Manufacture, 682  
 Maiden, J. H., Gums, Resins, and other Vegetable Exudations of Australia, 50  
 — Notes on Australian Botany, 58  
 — Plants of Lord Howe Island, 519  
 Maire, R., Research on Basidiomycetes, 211  
 — Taxonomic and Cytological Notes on *Botryosporium pulchellum*, 750  
 Maize, New Proteid, 49  
 Malacostraca, Excretory Organs, 38  
 Malaquin, A., Development of Metamers in *Salmacina oysteri*, 613  
 Malaria Parasites, Staining with TA-Methylen-Blue-Eosin, 108  
*Malaria perniciosæ*, Staining the Parasites, 108  
 Malaria, Species of Mosquito concerned in Diffusion, 37  
 Male Organs of Scatophaga, 607  
 Mallophaga from Galapagos Birds, 38  
 Malme, G. O. A. N., Kinodina, 753  
 Malt and Barley, Micro-organisms, 216  
 Malvaceæ, Biology of Fruit, 313  
 Malvoz, E., Compound Cilia, 77  
 Mammalian Egg, Fixation in Uterine Cavity, 769

- Mammals and Birds, Albinism, 712  
 Man, Results of Castration, 707  
 Mandibular Glands of Larval Lepidoptera, 495  
 Mangin, L., *Bornetina Corium*, 650  
 — Disease of Chestnut Trees, 333  
 — "Phthiriose," a Disease of the Vine, 531  
 Manipulation of Celloidin Sections, Apparatus, 238  
 Mann, G., Methods and Theory of Physiological Histology, 110  
 Männich, H., Development of Vertebral Column of Penguin, 283  
 Manson, Sir P., Life-Span of *Filaria medinensis*, 614  
 — Trypanosomiasis, 307  
 Marchal, E., Phytopathology, 653  
 — Rusts of Cereals, 648  
 — Synthesis of Proteids by Plants, 513  
 Marchantia, Development of Spermatozooids, 741  
 — Formation of Antherozoids, 321  
 — Rhizoid-Initials, 58  
 Marchoux, E., La Garotilha, 756  
 Marcinowski, E., Sub-oesophageal Ganglion of Liver-Fluke, 303  
 Marcuse, M., Mycorrhiza, 657  
 Marino, F., Non-Existence of "Neutrophil" Granulations in Leucocytes of Man and Monkey, 486  
 Marpmann, —, Cell-Nucleus of Saccharomyces and Bacteria, 68  
 Marpmann, G., New Imbedding Medium, 558  
 — New Medium for Mounting Microscopical Preparations, 560  
 Marshall, F. H. A., Oestrous Cycle and Carpus Luteum in Sheep, 484  
 Marshall, G. A. K., Seasonal Dimorphism in Butterflies, 35  
 Marsilia, Spore-cavity Nucleus in Prothallia, 320  
 Marsupella and Gymnomitrium, 743  
 Marsupialia, Marsupial Region, 710  
 Martelly, —, Putrefaction of Meat, 218  
 Martin, C. E., *Boletus subtomentosus*, 746  
 Martin, S., Chemical Products of Diarrhoea-producing Bacteria, 755  
 Massalongo, C., Italian Hepatics, 322  
 — Mycological Notes, 751  
 — Scapania, 321  
 Masee, G., *Chætomium Bostrychoides*, 206  
 — Diseased Pelargonium, 71  
 Mastication Muscles in Lacertilia, 712  
*Mastigocladus laminosus*, 657  
*Mastogloia fibriata* and *M. binotata*, 329  
 Matouschek, F., Austrian Muscineæ, 324  
 — European Hepaticæ, 199  
 — German Mosses, 324  
 Matrucho, D., Action of Freezing on Plant-Cells, 508  
 Matrucho, L., Action of Fermentation on the Cell, 745  
 Matrucho, L., Biology of *Piptocephalis*, 204  
 — Cultivation of Truffles, 643  
 — Mucorini, 333  
 Matte, H., Meriphyte of the Cycads, 733  
 Maturation-Mitosis, Heterotypic, in Amphibia, 707  
 Matzuschita, —, Physiology of Spore-formation in Bacteria, 339  
 Maurel, E., Relation between Weight of Liver and Total Surface, 599  
 Maurer, G., Staining the Parasites of *Malaria pernicioso*, 108  
 Maxon, W. R., Cuban Ferns, 58  
 — Ferns and Fern Allies of N. America, 195  
 — North American Pteridophyta, 741  
 Mayer, A. G., Atlantic Palolo, 300  
 — Evolution of Colour-Pattern in Lepidoptera, 291  
 Mayr, H., Disease of Fir Trees, 334  
 Mazé, P., Ripening of Seeds and Power of Germination, 315  
 Mazza, A., Algæ of the Gulf of Naples, 639  
 — New Nitophyllum, 637  
 — *Schimmelmännia ornata*, 527  
 Mazzarelli, G., Demonstrating the Structure of Gastropods, 368  
 Measures, British and Metrical Comparison, at the same temperature, 364  
 Meat, Putrefaction, 218  
 Meckel's Diverticulum and Concomitant Absence of Cæcal Appendix, 710  
*Medicago denticulata* and other Leguminous Plants, Root-tubercles, 217  
 Medullary Sheath Staining, Use of Paraffin Imbedding, 771  
 Meisenheimer, J., Crustacea and Pantopoda, 178  
 — New Pteropod, 603  
 Melander, A. L., Gynaecomorphism in *Hilara wheeleri*, 36  
 Melipona, Stingless Bees of Pará, 172  
 Mell, P. H., Biological Laboratory Methods, 240  
 Melobesiae, 202  
 Melosira, 633  
 Mengarini, M. T., Conjugation of Amœbæ, 503  
*Meningococcus intracellularis*, Characters, 343  
 Mennechet, L. A., Fruit of *Jacquinia ruscifolia* and Trichomes in Myrsinaceæ, 189  
 Mercerisation of Cotton Fabrics, 520  
 Mereschkowsky, C., Auxospores of Diatoms, 632  
 — Classification of Diatoms, 331  
 — Diatoms of the Black Sea, 199  
 — Endochrome of Diatoms, 633  
 — Lichmosphera, a New Genus of Diatoms, 64  
 — New Genera of Diatoms, 744

- Mereschkowsky, C., Polynesian Diatoms, 331  
 — Pyrenoids and Elaeoplasts in Diatoms, 200  
 — Structure and Division of Diatoms, 632  
 Meriphyle of the Cycads, 733  
 Merlin, A. A., Minute Structure of Triceratium, 62  
*Merulius lacrymans*, 532  
 Mesnil, F., Gall-forming Copepod in an Anemone, 300  
 — Hæmatozoa in Marine Fishes, 46  
 — Parasites of a Asiatic Tortoise, 46  
 Metabolism in Lichens, Products, 537  
 Metacephalic Segment, Innervation, 34  
 Metachromatic Corpuscles in Ascomycetes, 751  
 Metallography: An Introduction to the Study of the Structure of Metals chiefly by the Aid of the Microscope, 114  
 — Illuminating Apparatus, 97  
 Metalnikoff, S., Excretion in Gnat Larvæ, 173  
 Metals, Fracture under Repeated Alternations of Stress, 115  
 Metameres, Development in *Salmacina dysteri*, 613  
 Metamorphosis in *Amblystoma tigrinum*, Acceleration and Retardation, 707  
 — Physiological Study, 172  
 Metridium, Variations in, and Anemones, Notes, 45  
 Mennier, F., Diptera from Amber, 606  
 Meves, F., Dimorphism of Spermatozoa, 23  
 — Spermatogenesis in Drones, 719  
 Meyer, H., Researches on Tetanus, 661  
 Meylan, C., French Moss Flora, 61  
 Miall, L. C., Cricket of Aquatic Habits, 36  
 Mice, White, Growth in Weight, 489  
 Michael, A. D., 127  
 Michel, A., Species of Rhabditis, 180  
 Micheli, M., Mexican Leguminosæ, 626  
 Michelson Echelon Diffraction Grating, 228  
 Microbes, Agglutination by Blood of Emulsions, 756  
 Micrococcus, Flagellated, found in Septicæmia of Rabbits, 663  
 Microfungi, British, 751  
 — Polymorphism, 209  
 Micrographic Study of Cast Iron, 777  
 Micrometer, New, 112  
 Micrometers, Early Glass, 672  
 Micrometric Correction for Minute Objects, 579  
 — Microscope, Very Powerful, 761  
 Micromycetes rariores selecti, 535  
 Micro-organism infecting small Animals in the Laboratory, 342  
 Micro-organisms of Barley and Malt, 216  
 — Vital Staining, 773  
 Microphotometer for the Measurement of Light Absorption, Koenigsberger's, 362  
 Micropolariscope, Making Preparations of Crystals for, 110  
 Micropyle and Chorion in Cephalopods, 168  
 Microscope, Barbour's Pocket, 90  
 — Bausch and Lomb's New Pattern, 241, 349  
 — Beck's Metallurgical, 348  
 — — Pathological, 346  
 — — Portable Continental Model, 544  
 — — — "Star," 345  
 — — Process, 346  
 — Early Compound, with Mirror attached to its Limb, 590  
 — for Museum use, 379  
 — Helmholtz Theory of the, 381  
 — in Crucible Steel Manufacture, 682  
 — Lamp, New Electrical, 350  
 — Leitz' Mineralogical Stand, No. I., 758  
 — — — No. II., 758  
 — Leitz' New Stand and Fine Adjustment, 665  
 — New Binocular, 85  
 — — Portable, 543  
 — Old, 241  
 — — by M. Pillischer, 542  
 — — Non-Achromatic Simple, 587  
 — On the Theory of Optical Images, with Special Reference to the, 447  
 — — Supplementary Paper, 474  
 — Portable Class, 89  
 — — Watson's New Pattern, 670  
 — The, 678  
 — Used by Gosse, 118  
 — Very Powerful Micrometric, 761  
 — Watson and Sons' Metallurgical, 86  
 — — — Museum, 88  
 — Watson's Van Heurck, Method of fitting Stage and Limb, 88  
 — with a Tomes' Stage, by Pillischer, 245  
 Microscopic Examination of Paper Fibres, 111  
 — Objects, Colour Illumination, 671  
 — Vision, Common Basis of the Theories treated without the Aid of Mathematical Formulæ, 102  
 — — On the "Lag" in, 583  
 Microscopical Diagnosis of Intermittent Fever, Improved Method, 236  
 — Examination of Foods and Drugs, 561  
 — — of Paper, 774  
 — Preparation, A Modification of the Pantograph for Drawing, 777  
 — — New Medium for Mounting, 560  
 — Stand, New, with Movable Stage, capable of Large Movements, 670  
 — Technique, Encyclopedia, 373  
 Microscopy, Modern, 111  
 — Plant, 58  
 Micro-Skeletons, Cartilaginous, Method for Demonstrating, 372

- Microspectral Objective, Engelmann's, with Detachable Thorpe's Grating and Detachable Polariser, 351
- Microspectralphotometer with Grating Spectrum, Engelmann's, 359
- Microthamnion, 197
- Microtome, Hand, New Freezing Plate, 558
- Jung's New Student, 230
- Reichert's Sliding, Improvement, 231
- the Minot, New Razor-holder and adjustable Clamp, 234
- Midges, Net-winged, 292
- Mid-Gut and Hind-Gut, Connection between in Larval Hymenoptera, 720
- Gland of Crayfish, Function, 178
- Migone, E., Demonstrating Trypanosomata, 371
- Mildew of Gooseberry in Europe, 335
- Milk, *Coccus lactis viscosi* and the Causes of Sliminess and Threads, 216
- New Bacterium in Freshly-drawn, 343
- Researches on Fermentation, 756
- Milk-Agar as a Medium for the Demonstration of the Production of the Proteolytic Enzyme, 679
- Milk-Ducts of Cow, Bacteria, 83
- Miller, C. H., Imbedding in Celloidin, 770
- Millett, F. W., Report on the Recent Foraminifera of the Malay Archipelago, collected by Mr. A. Durrand, 253, 377, 685, 780
- Mills, F. W., Diatomaceæ of the Hull District, 63
- Milroy, J. A., Staining Reactions of Proteid Crystals, 236
- Mimicry, Protective, in a Caterpillar, New Case, 494
- Mineral Waters, Natural, Bacteriology, 83
- Minot, C. S., Laboratory Text-Book of Embryology, 483
- Minot Microtome, New Razor-holder and Adjustable Clamp, 234
- Mirror, Koristka's Large Reflecting, 349
- Mirsky, B., Aspergillæ Parasitic on Human Beings, 749
- Mites, Fresh-water and Irish, 496
- Mitosis in Pellia, 620
- in Synchytrium, 620
- Miura, K., Unfertilised Ova of Ascaris in Human Faeces, 614
- Mixed Jet, Arrangement for Obtaining Monochromatic Light with, 15
- Miyabé, K., Laminariaceæ and Laminaria Industries of Hokkaido, Japan, 527
- Mnium, Two Egg-Cells, 323
- Molgalid, New, 602
- Molisch, H., Blue Diatom, 330
- Floating Properties of Certain Phycocromaceæ, 339
- Molisch's Freezing Apparatus, 103
- Möller, A., *Merulius lacrymans*, 532
- Molliard, M., Action of Fermentation on the Cell, 745
- Action of Freezing on Plant-cells, 508
- Culture of *Sterigmatocystis nigra*, 651
- Molluscivorous Diet, Adaptations to, in *Varanus niloticus*, 712
- Monasciæ, Digestive Glands, 489
- Monascus, Morphology and Development of the Ascocarp, 206
- Monascus purpureus*, Systematic Position, 746
- Monaxonia, Insufficiently Described, 729
- Monilia Disease, 529
- Monilia fructigena*, 208
- Mönkmeyer, W., German Mosses, 324
- Monks, S. P., Regeneration of the Body of a Starfish, 616
- Monoblepharis, Notes, 640
- Monochromatic Light Apparatus, New, 378, 674
- — Arrangement for Obtaining with the Mixed Jet, 15
- Monograptus, Occurrence in New South Wales, 728
- Monophyllæa and Streptocarpus, Regeneration of Assimilating Mechanism, 733
- Monostome, New, from Snapping Turtle, 615
- Monstrosities in Bivalves, 33
- Montemartini, L., Aristolochiaceæ, 519
- New Parasitic Fungi, 206
- Montgomery, F. E., Method of Preparing Sugar-free Bouillon, 767
- Montgomery, T. H., Morphology of the Rotatorian Family Flosculariadae, 727
- Montgomery, T. H. jr., Heterotypic Maturation-Mitosis in Amphibia, 707
- Structure of a *Paragordius varius*, 725
- Monus vulgaris*, Observations, 618
- Moore, G. T., Cultivation Medium for Algae, 767
- Moore, J. E. S., Cytology of Apogamy, 740
- Reduction of Chromosomes, 732
- Morel and Doléris, Modification of the Method for Staining with Ehrlich Triacid Solution, 560
- Morgan, —, New Hyphomycetes, 529
- Morgan, A. F., Lepidoderma, 344
- Morgan, H. de R., The Bactericidal Action of Some Ultra-Violet Radiations as Produced by the Continuous-Current Arc, 756
- Moroff, T., New Pennatulacea and Gorgonacea, 184
- New Species of Chilodon, 46
- Morphology of Lichens, 753
- Morse, M., North American Trichodectidæ, 722
- Morteo, E., Rare Lichen from Liguria, 70
- Moser, F., Comparative Embryology of the Swim-Bladder, 708
- Development of Vertebrate Lung, 25
- Mosquitos in Winter, 606

- Mosquitos, Species concerned in Diffusion of Malaria, 37
- Moss Exchange Club, 325
- Flora, British, 60
- — French, 61
- — of Australia, 524
- — of French Caverns, 61
- Intercconversion of Sexual Organs, 59
- Moss, R. J., Fungicides, 652
- Mosses, American, 628, 742
- British, 323, 523
- European, 198, 323, 628, 741
- Fertilisation and Spore-Ripening, 522
- German, 61, 323
- Inconspicuous, 325
- Italian, 324, 524
- Japanese, 61
- N. American, 324, 524
- of Alaska, 324
- of Central Switzerland, 199
- of East Greenland, 325
- Rhizoids, 627
- West African, 742
- Moss-Species, Suppression of Redundant, 60
- Moth, Death's-Head, Stridulation, 34
- Mottier, D. M., Behaviour of the Chromosomes in the Spore-Mother-Cells of Higher Plants, 505
- Moulds, Nitrogen Assimilation, 190
- Proteid Formation, 528, 534
- Mounting Bacteria from Fluid Media, Method, 561
- Microscopical Preparations, New Medium, 560
- Moussu, —, Reappearance in Offspring of Lesions Artificially induced in the Mother, 22
- Mouth-parts of Insects, 34
- Mucorini, 333
- Spore-Formation, 745
- Zygosporae, 746
- Mud-Sucker and Throwing-Net, 167
- Müller, F., Improvements of Aubertin's Method for Sticking on Celloidin Sections, 769
- Müller, F. W., Apparatus for Photographing with Light incident from above and below, 355
- Müller, J., Contributions to Study of Bipaliidae, 182
- Studies on Bipalium Species, 41
- Müller, K., European Hepaticae, 198
- Hepaticae of Baden, 59
- Müller, O., Melosira, 633
- Muller, P. E., Mycorhiza, 751
- and Another, Mycorhiza, 533
- Müller-Thurgau, H., Disease of the Vine, 334
- Multicilia lacustris*, 618
- Münch, K., Cross-Striped Muscle, 596
- Structure of Nucleus in Smooth Muscle, 596
- Murbeck, S., Life-History of *Ruppia*, 311
- Murlin, J. R., Absorption and Secretion in Terrestrial Isopods, 39
- Murray, G., Diatoms of the Atlantic, 634
- Murriel, W. A., N. American Polyporeae, 72
- Polyporeae of N. America, 536
- and Others, American Fungi, 654
- Muscidae, Development of Nervous System, 37
- Muscineae, Austrian, 324
- European, 197
- French Volcanic, 323
- German, 524
- Morphology, 627
- of Atlantic Islands, 62, 197
- of Galapagos Islands, 62
- of South-East Asia, 61
- Yorkshire, 323
- Muscle, Cross-Striped, 596
- Smooth, Structure of Nucleus, 596
- White, Nerve-Endings, 284
- Muscle-fibrils, Molecular Structure and Histology, 26
- Muscular Apparatus of Anomia, 171
- Terminations of Nerve-Fibres, 27
- Musculature and Skeleton in *Spelerpes longicaudus*, Development, 595
- Musgrave, W. E., Trypanosomiasis of Horses in the Philippines, 619
- Muyneck, A. de, Sugar in Ripe Fruits, 192
- Mycologicae, Notae, 537
- Mycological Notes, 751
- Mycology, American, 536
- British, 533
- Technical, 538
- Mycoplasma Hypothesis, 749
- Mycorhiza, 533, 657, 751
- Endophytic, Cytology and Physiology, 213
- Myoblasts, 595
- Myonemes of Protozoa, 618
- Myricaceae, Monograph, 57
- Myriopods and Insects, Joints in the Walking Legs, 604
- Marine, 722
- New, 297
- Structure, 177
- Myrmecophils, Termites and Termitophils New, 172
- Myrmecophily in *Macaranga triloba*, 625
- Myrsinaceae, Trichomes, and Fruit of *Jacquinia ruscifolia*, 189
- Mysis oculata* and *Mysis relicta*, Intermediate Form between, 611
- Mytilus gallo-provincialis*, Origin of Pearls in, 291
- *latus*, Two Remarkable Sporocysts, 726
- Myxinoids, Coloration, 599
- Morphology, 487
- Myxomycetes, Culture, 84
- Myxosporidian Parasite of *Geophilus*, 618



## N.

- Nabarro, D., Detection of Trypanosomes, 775
- Nachet, —, New Microscopical stand with Movable Stage capable of Large Movements, 670
- Nadson, G., Perforating Algæ, 658
- Narcotising Medium for Aquatic Animals, Ether as, 368
- Nash, G. V., Revision of the Family Fouquieriaceæ, 738
- Nathansohn, A., New Group of Sulphur-Bacteria, 540
- Naucois cimicoides*, Normal Asymmetry of Wings, 174
- Nautilus, Nervous System, 490
- Nebalia, Fibrillar Continuity of Epithelial Cells and Muscles, 38
- Nebel, A., Demonstration of Tubercle Bacilli in Sputum, 767
- Nectria moschata*, 69
- Necturus, Nuclear Changes in Striped Muscle-Cell, 27
- Neger, F. W., Studies of Erysipheæ, 747
- Neidert, L., Structure and Development of Female Gonads of Lancelet, 594
- Nelson, E. M., Comparison of British and Metrical Measures at the Same Temperature, 364
- Early Compound Microscope with a Mirror attached to its limb, 590
- Early Glass Micrometers, 672
- Improved Horseshoe Stage, 591
- Leitz' New Stand and Fine Adjustment, 668
- Micrometric Correction for Minute Objects, 579
- Micrometry, 570
- Old Non-achromatic Simple Microscope, 562, 587
- On the "Lag" in Microscopic Vision, 583
- Two-speed Fine Adjustment, 19, 117
- Nelson, N. P. B., Water-Bloom, 658
- Nematocyst Cells in Hydra, Method for Demonstrating, 237
- Nematocysts of Nudibranchs, 291
- Némeç, —, Non-Sexual Nuclear Fusions, 506
- Nemertans of Norway, 726
- Nemiloff, A., Amitotic Division in Vertebrata, 595
- Nephthyidæ, Revision, 728
- Nerve-Cells, Intracellular Threads, 596
- Nerve-Cord, Ventral, of Crayfish, 299
- Nerve-Endings on White Muscle, 284
- Nerve-Fibres in Fishes, Size, 284
- Muscular Terminations, 27
- Nerves, Endings in Salivary Glands, 27
- Nervous System in Insects, Metamorphosis, 604
- Nervous System in Muscidæ, Development, 37
- — of Nautilus, 490
- Neufeld, R. P., Canaliculi in Ganglion Cells, 708
- Neumann, L. G., Species of Ixodidæ, 496
- Neurons, Efferent, in Electric Lobes of Torpedo, 487
- Neutral Red, Fixing, 106
- — Use in the Study of Phagocytosis, &c., 78
- "Neutrophil" Granulations, Non-Existence in Leucocytes of Man and Monkey, 486
- Neuville, H., Industrial Ferments of Eastern Asia, 337
- Newcombe, F. C., Thigmotropic Root-Curvatures, 192
- Newton, C. R., Enzyme in Ripening Plantains, 56
- Newton's Colours. Method of Demonstrating by Transmitted Light, 672
- Newt's Ova, Maturation, 281
- Regeneration, 161
- Nichols, A. R., List of Irish Echinoderms, 728
- Nicholson, W. E., *Weisia sterilis*, 742
- Nieolle, —, Agglutination, 78
- Niedloff, T., Floral Structure of Juglandæ, 314
- Nierstrasz, H. F., New Solenogastres, 717
- Nilson, B., Morphology of Lichens, 753
- Nishineki, V., Unfertilised Ova of *Asearis* in Human Fæces, 614
- Nitella batrachosperma*, 631
- Nitophyllum, New, 637
- Nitrogen, Alkaloids as a source, 737
- Nitrogen-Assimilating Bacteria, 659
- Nitrogen Assimilation in Moulds, 190
- Nitrogen-Fixing Bacteria, 540
- Nitrogenous Metabolism in Minute Algæ, 623
- Nitroso-Bacterium, Culture, 540
- Nomenclature, Notes, 651
- of Uredineæ, 650
- Non-Achromatic Simple Microscope, An Old, 587
- Norman, A., Sanger-Shepherd Process of Colour Photography, 121
- Norman, A. M., Echinoderms of East Finmark, 728
- Norton, J. B. S., *Monilia fructigena*, 208
- Notoneceta, Aerosome of Spermatid, 295
- Notoneceta glauca*, Development of Spermatid, 295
- — "Nebenkern" and Nuclein Movements in Spermatid, 296
- Nuclear Behaviour and Spore-Formation in *Hydrangeum carneum*, 750
- Division of Amoeba, 305
- Emissions in Protozoa, 305
- Fusions, Non-Sexual, 506

Nuclear Membrane, Relationship to the Protoplast, 506  
 — Reduction and Fertilisation in Paris and Trillium, 48  
 — Structure, Criticism of Theories, 27  
 Nuclei, Behaviour in Plant Hybrids, 506  
 — in Yeast and Animal Cells, Study, 205  
 — of Unicellular Animals contrasted with those of Plant Cells, 47  
 Nucleolar Changes in Secretion of Hepato-Pancreatic Cells of Hermit-Crab, 178  
 Nucleolus, Observations, 49  
 Nucleus in Smooth Muscle, Structure, 596  
 — of Spirogyra, 48  
 — of Spore-cavity in Prothallia of Marsilia, 320  
 — Parental and Grand-parental Components, 281  
 Nudibranchs, Nematocysts, 291  
 Numerical Aperture and Rapidity, 765  
 Nutting, E. S., Fixing of Blood-Films and the Triacid Stain, 229  
 Nypels, P., Disease of the Alder, 644

## O.

Objective, Correction Distance, Graphic Representation, 762  
 Objectives, Injurious Effect of Cement upon, 762  
 Objects, Small, New Method of Imbedding, 233  
 Ocular, Bourguet's New Index, 91  
 Odin, G., Origin of Yeast, 68  
 Oögonium, 65  
 Oöstrous Cycle and Corpus luteum in Sheep, 484  
 Oestrup, E., Diatoms of Koh Chang, 330  
 Oidium Production and the Culture of the Higher Fungi, 75  
 Okamura, K., Japanese Marine Algæ, 744  
 — Vegetative Reproduction in *Chondria crassicanlis*, 330  
 Oligochætæ, Examining, 106  
 — Typical Chlorogogen, 300  
 Olive, E. W., Acrasiæ, 752  
 Oliver, F. W., Fossil Fungi, 534  
 — *Lagenostoma Lomaxi*, the Seed of Lyginodendron, 622  
 Onion, Starch-Grains in Root-Cap, 508  
 Onychophora, Modes of Development, 297  
 Oogenesis and Spermatogenesis in *Sagitta bipunctata*, 498  
 — — of *Cyclops strenuus*, Maturation Phenomena, 39  
 — in Lepidoptera, 496  
 — in Mammals, Note, 22  
 — in Saprolegnia, 642  
 Ophidia, Hæmogregarines, 307  
 Opisthobranchs from Gulf of Siam, 32

Optical Images, On the Theory of, with Special Reference to the Microscope, 447  
 — — Supplementary Paper, 474  
 Optics, Drude's Theory, 765  
 Orchids, Germination: a Symbiotic Relationship, 737  
 Orfeur, F., 241  
 Ornithorhynchus, Early Stages in Development, 282  
 Orthoptera, N. African, Chemical Defence and Other Adaptations, 174  
 — Saltatorial, Stridulating Organs, 296  
 Orthotrichum in the United States, 196  
 Osborn, H. L., Peculiar Fluke, 303  
*Oscillaria prolifica*, Chemical Composition, 76  
 Osculatia and Schwetschkea, Notes, 60  
 Osmotic Pressure of different Media, Resistance of *Gasterosteus aculeatus*, 714  
 — Properties of Cells of Cyanophycæ, 658  
 Ostefeld, C. H., Diatoms of Koh Chang, 330  
 — Phytoplankton of Lakes in the Façades, 744  
 Östergren, H., Ether as a Narcotising Medium for Aquatic Animals, 368  
 Osterwald, K., and Another, German Muscinæ, 524  
 Ootocysts of Polychætæ, 301  
 Oudemans, C. A. J. A., Critical Notes on Fungi, 76  
 — Fungus Flora of Humus, 74  
 Oudemans, J. T., Position of Repose in Lepidoptera, 719  
 Ova, Influence of Radium Rays on, 483  
 — of *Ascaris*, Unfertilised, in Human Fæces, 614  
 — of *Cristiceps argentatus*, Artificial Fertilisation, 593  
 — of Starfish, Experiments, 501  
 — Ovarian, and Follicles in Fishes, 594  
 Ovarian Follicle of Amphibians, Retrogressive Changes, 22  
 Ovary and Testis, Mammalian, Embryonic Development, 706  
 — in Cephalopods, Structure, 490  
 Ovule, Development in Casuarina, 736

## P.

Pace, S., Structure of Pontiothamna, 491  
 Pailheret, F., Action of Alcoholic Fermentation on the *Bacillus typhosus*, 80  
 Paired Limbs of Vertebrates, Origin, 29  
 Palacký, J., Geographical Distribution, 167  
 Palæartic Forms of Clausilia, Synopsis, 492  
 Palæospondylus, 714  
 Palæozoic Stems, Primary Structure, 193  
 Pallaci, G., New Parasitic Fungi, 206

- Palmer, F. C., New Species of Tracheomonas, 504
- Palms, Reserve Carbohydrates of the Albumen, 49
- Palolo, Atlantic, 300
- Japanese (*Ceratocephale osawai*, sp. n.), Observations, 724
- Pammel, L. H., Diseases of Grasses, 751
- Pampaloni, L., Fossil Fungi, 74
- Pantel, J., Acrosome of Spermatid of Notonecta, 295
- Development of Spermatid of *Notonecta glauca*, 295
- "Nebenkern" and Nuclein Movements in Spermatid of *Notonecta glauca*, 296
- Pantocsek, J., Fossil Diatoms, 635
- Hungarian Diatoms: Lake Balaton, 200
- Pantograph for Drawing Microscopical Preparations, Modification, 777
- Pantopoda and Crustacea, 178
- Paper Fibres, Microscopic Examination, 111
- Microscopical Examination, 774
- Soluble Glass as a Mounting Medium for Examination of, 774
- Papilio podalirius*, Sensory Hairs on Pupa, 175
- Pappenheim, P., Development of *Dolomedes fimbriatus*, 298
- Paraffin Imbedding, New Method, 369
- Use for Medullary Sheath Staining, 771
- Sections, Thin, Simple Method of Making, 105
- Paragordius varius*, Structure, 725
- Parasite of a Central S. American Horse Disease, 619
- of Hermit-Crabs, New, 730
- of Texas Fever, 618
- Parasites, Asiatic Human, 302
- Marine, in Fresh-water Fishes, 499
- of an Asiatic Tortoise, 46
- Phanerogamic, Lime in, 192
- Parasitism, adaptive, of *Puccinea dispersa*, 649
- among Animals, 487
- Interesting Case, 720
- of *Buckleya Quadriala*, 51
- of *Puccinea*, Effect of Mineral Starvation, 210
- Paratyphoid Fever, 344
- Paris and Trillium, Nuclear Reduction and Fertilisation, 48
- Paris, E., West African Mosses, 742
- Paris, E. G., Japanese Mosses, 61
- Muscineæ of South-east Asia, 61
- Parker, G. H., Optic Chiasma in Teleosts, 287
- Sense of Hearing in Fishes, 713
- Parkin, J., Botany of the Ceylon Patanas, 739
- Parthenogenesis, Artificial, 22
- Agency of Carbon Dioxide in inducing, 21
- Carbonic Acid as a Provocative, 21
- in Egg of *Podarke obscura*, 498
- in Silk Moth, 494
- Particles and Bacteria, Ultra-Microscopic, on the Rendering Visible, 573
- Patouillard, N., Extra-European Fungi, 215
- Fungi from New Caledonia, 535
- and Others, Systematic Notes on Fungi, 656
- Patten, W., Appendages of Tremataspis, 714
- Patterson, J. H., Salmon Disease, 755
- Paul, H., Rhizoids of Mosses, 627
- Peal, H. W., Vasiform Orifice of the Aleurodidae, 721
- Pearls, Formation, 170
- Frequency of Occurrence, 493
- Origin in *Mytilus gallo-provincialis*, 291
- Pearson, H. H. W., Botany of the Ceylon Patanas, 739
- Peas, St. John's Disease, 338
- Peck, J. W., Differential Stain of *Bacillus Diphtheriæ*, 370
- Pecten, Innervation of Mantle, 33
- Peglion, V., Destruction of Seeds by Fungi, 644
- Potato Disease, 644
- Peirce, G. J., Root-tubercles of *Medicago denticulata* and other Leguminous Plants, 217
- Pelargoniums, Diseased, 71
- Pellegrin, J., Curvature of the Spine in Fishes, 161
- Pellia, Mitosis, 620
- Pelvegia fastigiata*, 636
- Pelycosauria, American, 601
- Penard, E., *Multicilia lacustris*, 618
- New Rhizopod, 305
- Penguin, Development of Beak, 283
- Development of Vertebral Column, 283
- Penicillium, Influence of Substratum on Germination of Spores, 645
- Pennatulacea and Gorgonacea, New, 184
- Pensa, A., Endings of Nerves in Salivary Glands, 27
- Structure of Cartilage Cells, 27
- Penzig, O., Plant Teratology, 58
- Percival, A. S., The Microscope, 672
- Pérez, C., New Type of Salpa-Chain, 490
- Perforating Algae, 658
- Perianth Leaves of Tulip and Crocus, Movement, 191
- Peridineæ and Algæ, German, 524
- Periodicity of Morphological Phenomena in Plants, 515
- Peripatus, New Species, 608
- Peristome, 60
- Perkins, H. F., Development of *Gonionemum turbachii*, 501

- Perkins, J., Notes on Styracæ, 57  
 — Revision of the Species of *Lisianthus*, 57  
 Perlid, Larval, Tracheal Gills on Legs, 607  
 Peroxides, Function in the Living Cell, 317  
 Perrédès, P. E. F., Poisonous Action and Histology of Stem of *Derris uliginosa*, 520  
 Perroncito, —, *Lambliia intestinalis*, Fatal to Rabbits, 46  
 — Production of Hydatid Cysts from Scolices, 42  
 Perroncito, A., Muscular Terminations of Nerve-Fibres, 27  
 Pesci, L., Permeability of Frog's Skin, 30  
*Petalonema alatum*, 658  
 Petiolar Glands of *Viburnum Opulus*, 510  
 Petiole in the Flower, Theory, 52  
 Petit, L., Distribution of Spherulin among Plant Families, 309  
 Petri, L., *Peziza vesiculosa*, 644  
 — Spore-formation in *Gastromycetes*, 211  
 Petrow, —, New Red Pigment-forming Bacillus, 342  
 Petrunkewitsch, A., History of Polar Bodies in Drone-Ova, 293  
*Peziza vesiculosa*, 644  
 Pflanzenkrankheiten, Jahresbericht, 534  
 Phœodaetylon and Centronella, 200  
 Phagocytic Absorption of Sex-Cells in *Echinocardium cordatum*, 727  
 Phagocytosis, &c., Use of Neutral Red in the Study, 78  
*Phalangista vulpina*, Spermatogenesis, 24  
 Phalloideæ, New Member, 73  
 Phanerogamic Parasites, Lime in, 192  
 Phanerogams, Existence of Pith in the Leaf-Stalk of, 509  
 Phasmid, Tasmanian, 721  
 Phasmidæ, Malayan, and a Flower-like Beetle Larva, 36  
 Philip, R. H., Diatom Records, 635  
 — Diatomaceæ of the Hull District, 63  
 Phisalix, M., Origin of Poison Gands in the Land Salamander, 713  
 Phoronis, Correct Name of Genus, 500  
 Phosphorus in Plants, Detection, 49  
 Photographic Lenses, 677  
 Photographing with Light incident from above and below, Apparatus, 355  
 Photographs of Images seen in Binocular Microscopes, 783  
 Photography by Natural Lenses, 764  
 — Stereoscopic, of Microscopic Objects, 100  
 Photomicrographic Apparatus, New Upright, 224  
 Photomicrographs in Colours, New Arrangement for taking, 118  
 Photomicrography, Elementary, Bagshaw's, 101  
 — New Method of Focussing, 677  
 — — — of Using the Electric Arc, 276  
 Photomicrography of Opaque Objects as applied to the Delineation of the minute Structure of Chalk Fossils, 242  
 — Small Electric Light for, 95  
 — Staining Directions, 234  
 — Stereoscopic, New Device, 223  
 — — with weak Magnification, 674  
 Photosynthesis, 54  
 — outside the Plant, 314  
 Phototaxis in *Volvox*, 730  
 Phototropism of *Daphnia*, Note, 497  
 Phrynosoma, Note, 488  
 "Phthiriose," a Disease of the Vine, 531  
 Phycochromaceæ, Floating Properties, 339  
 Phycomyces, 641  
 — Fertilisation, 68  
 Phyllopod, Australian, 300  
 Phylogenetic Speculations, 166  
 Phylogeny of Chelonians, 712  
 — of Erinacidae, 167  
 — of Vomerine Bones, 710  
 Physiological Histology, 110  
 Physiology, Chemical, of Invertebrates, 598  
 Phytopathology, 653  
 Phytoplankton of Lakes in the Faerœs, 744  
 — of the Thames, 63  
 Pictet, A., Changes in Imagines induced by Change of Diet in Caterpillars, 294  
 Pierce, N. B., Sectioning Fresh Plant Tissues, 231  
*Pieris napi*, Variations, 493  
 Pig, Circulation in Labyrinth of Ear, 711  
 Pigment, Black, Formation in Tumours of Horse, 488  
 Pigment-Bodies and Endothelial Derivatives in Gephyreans, 613  
 Pigment-forming Bacillus, New Red, 342  
 Pillischer, J., An Old Microscope, with a Tomes' Stage, 245  
 Pillischer, M., Old Microscope, 542  
*Pilostyles Ingæ*, 188  
 Pinchot, G., Forest Destruction in the United States, 520  
 Pineal Body, Development in Amphibia, 594  
 Pine-Beetle, 721  
 Pines, Histology of the Wood in Species, 188  
 Pinoy, —, Culture of *Myxomycetes*, 84  
 Piperaceæ, Development, 511  
 Piptocephalis, Biology, 204  
 Pischinger, F., Regeneration of the Assimilating Mechanism in *Streptocarpus* and *Monophyllæa*, 733  
 Pith, Existence in Leaf-Stalk of Phanerogams, 509  
 Pittaluga, G., *Anopheles* in the Iberian Peninsula, 606  
 Pittard, E., Results of Castration in Man, 707  
 Plague Bacillus, Staining, 108

- Planaria maculata*, Life-History and Reproduction, 614  
 Plankton, Atlantic, 526  
 Plankton-Diatoms, Variations - Statistics, 63  
 Plankton of Alt-Anseeer Lake, 199  
 — of Lake Nyassa, 327  
 — — — and Other Mid-African Lakes, 526  
 Plant-Anatomy, Pathological, 621  
 — Cells, Action of Freezing, 508  
 — Disease, Wild Plants as Nurseries, 653  
 — Diseases, Distribution, 207  
 — Growth, Relations to Ionisation, 56  
 — Life, Influence of Light and Darkness, 316  
 — Microscopy, 58  
 — Nutrition, Changes in Salicin, 517  
 — — Function of Calcium Oxalate, 515  
 — Protoplasm, Functional Inertia, 191  
 — Rusts, Problems in the Study, 531  
 — Teratology, 58  
 — Tissues, Fresh, Sectioning, 231  
 — — Specific Double Refraction, 765  
 Plantains, Enzyme in Ripening, 56  
 Plants, Action of Sodium Fluoride and Potassium Iodide and Potassium Ferrocyanide, 518  
 — — of Uranium, 518  
 — and Animals, Arsenic in, 186  
 — Carburetted Hydrogen and Hydrogen formed by, 516  
 — Decomposition and Regeneration of Albuminoides, 317  
 — Deprived of their Cotyledons, Nutrition, 624  
 — Detection of Phosphorus in, 49  
 — Effect of Composition of Soil, 190  
 — Green, Assimilation, 514  
 — of Catalonia, 318  
 — of Lord Howe Island, 519  
 — Penetration by Bacteria, 216  
 — Periodicity of Morphological Phenomena, 515  
 — Physical Conditions of Tuberisation, 54  
 — Synthesis of Proteids, 513  
 — Wild, as Nurseries of Plant-Disease, 653  
 — Woody, Variation in Carbohydrate Reserves in Stem and Root, 191  
*Plasmodium Præcox*, 619  
 Plasmopara, Fertilisation, 745  
 Plate, L., Studies in Cyclostomes, 599  
 Plateau, F., Poppies and Insect Visitors, 518  
 Platinum Metals, Volatilisation and Recrystallisation, 115  
 Platystrophia, Evolution, 615  
 Plečnik, J., Carbon tetrachloride as a Clearing Fluid, 370  
 Pleospora and Helminthosporium, Relationship, 747  
 Pleuronectids, Abnormal Coloration, 166  
 Plowman, A. B., Relations of Plant Growth to Ionisation, 56  
 Plowright, C. B., British Mycology, 533  
 Pneumococcus which liquefies Gelatin, 343  
 Poche, F., Correct Name of Genus *Phoronis*, 500  
 Poche, R., Flagellate Parasites in Siphonophora, 306  
 Pöcock, R. I., New Claspings-Organ in a Centipede, 496  
*Podarke obscura*, Artificial Parthenogenesis in Egg, 498  
 Podpera, J., Plant-Formations and Flora of South Bulgaria, 57  
 Polar Bodies in Drone-Ova. History, 293  
 Polariser, Reflecting, Simple Form, 99  
 Polarising Vertical Illuminator, Improved, and use of Birefringence. Improved Method of Identifying Crystals in Rock Sections, 683  
 Poll, H., New Electrical Microscope Lamp, 350  
 Pollacci, G., Assimilation in Green Plants, 514  
 — Hydrogen and Carburetted Hydrogen formed by Plants, 516  
 Pollen-Grains, Germination, 53  
 Pollen in Aselepiads, Development, 53  
 Polychæta, Ootocysts, 301  
 Polychæts, Fresh-water, 301  
 Polyclad, Fresh-water, 182  
*Polydesmus exitiosus* and *Alternaria Brasiceæ*, 338  
 Polygordius, Notes, 301  
*Polymnia nebulosa*, Rôle of Amœbocytes, 724  
 Polymorphism of Marine Algæ, 636  
 — of Microfungi, 209  
*Polyodon folium*, Lateral Canals and Cranial Bones, 288  
 Polyporeæ, N. America, 72  
 Polyporeæ of N. America, 536  
 Polysaccharides, Hydrolysis, 517  
 Pond Life, Exhibition, 380  
 — — Slide, 239  
 Pontiothauma Structure, 491  
 Poole, H. S., Stigmaria, 521  
 Poppies and Insect Visitors, 518  
*Porliera hygrometrica*, Anatomy and Movements, 510  
 Porsild, M. P., New Double-hinged Limbholder, 545  
 Porta, A., Hepatic Function in Insects, 173  
 — Reproduction of Acanthometridæ, 45  
 Portable Microscope, New, 543  
 Portier, P., Temperature of the Tunny, 600  
 Potato Disease, 644  
 — Diseases, 213  
 Potatoes, Experiments, 516  
 Potter, M. C., Potato Diseases, 213  
 — Septoria, 337  
 Powell, C., Calcareous Pebbles, 658

- Power, F. B., Poisonous Action and Histology of Stem of *Derris uliginosa*, 520
- Powers, J. H., Acceleration and Retardation of Metamorphosis in *Amblystoma tigrinum*, 707
- Præfemur and Trochanter, 175
- Pranter, V., New Methods of Paraffin Imbedding, 369
- Pratt, H. S., N. American Trematodes, 41, 303
- Prenant, A., Myoblasts, 595
- Myonemes of Protozoa, 618
- Prepotency in Polydaetyulous Cats, 24
- Preputial Glands of Rabbit, 486
- Preservation and Staining of Serial Sections and Paper Strips, 371
- President, The, 121, 122, 126, 127, 128, 241, 242, 243, 244, 245, 252, 376, 377, 379, 380, 786
- President's Address, 'Some Ideas of Life,' 126, 142
- Preswisch, J., Calcareous Sponges from the Pacific, 729
- Projection Apparatus for Scientific Work, New, 549
- Microscopic, Koristka's Apparatus for Liquid Preparations, 553
- Prophysema hæckelii*, 617
- Protective Resemblance in Butterflies, 719
- Proteid Crystals, Staining Reactions, 236
- Formation in Moulds, 528, 534
- New, from Maize, 49
- Proteids, Synthesis by Plants, 513
- Proteolytic Ferments, 625
- Protohydra leuckharti*, Division, 44
- Protomycetes, Taphridium, A New Genus, 331
- Protoplasm and Enzymes, Nature, 624
- Continuity, 47
- Protoplasmic Streaming, 308
- Protoplast, Relationship to Nuclear Membrane, 506
- Protozoa, Myonemes, 618
- Nuclear Emissions, 305
- Prunet, A., *Botrytis vulgaris* on Figs, 529
- Prunus, Prussic Acid in Opening Buds, 516
- Prussic Acid in Opening Buds of Prunus, 516
- Pseudogyny in Formica, and its Cause, 172
- Pseudoscope Lens, 762
- Pseudoscorpionidæ, Segments, 298
- Ptilopilum, 325
- Pteridophyta, East Asiatic, 740
- German, 521
- N. American, 521, 741
- Pteroccephalus, Sexual Reproduction, 729
- Pteropod, New, 603
- Ptychodera erythrea* from the Red Sea, 183
- Puccinæ, Experiments, 648
- Puccinia dispersa* and its adaptive Parasitism, 649
- Puccinia, Effect of Mineral Starvation on the Parasitism, 210
- Puchberger, G., Vital Staining of Blood-Plates in Man with "Brillantkresylblau," 773
- Pulmonata, Aëriferous Canal in Shell, 492
- Punnett, R. C., Nemerteans of Norway, 726
- Pupal and Imaginal Organs, Precocious Development in Caterpillars, 605
- Purple of Dog-Whelk, 170
- of *Purpura lapillus*, 290
- Purpura lapillus*, Purple of, 290
- Putrefaction of Meat, 218
- Pyrenoids and Elæoplasts in Diatoms, 200
- Pyrocystææ, 62
- Pyroxene, Note on the Amphibole Hudsonite previously called a, 777
- Pyrrhocoris apterus*, formation of Chorion, 607
- Python reticularis*, Acid-fast Bacillus in, 660
- Q.
- Quelle, F., Rhizoid-Initials of Marchantia, 58
- Queva, C., Unipolar Stele in Rootlets of *Trapa*, 509
- R.
- Rabbit Pest in Australia, 29
- Preputial Glands, 486
- Rabbits, *Lambliæ intestinalis*, Fatal to, 46
- Rabl, C., Development of External Body-Form, 24
- Rabenhorst's Kryptogamen-Flora: Fungi imperfecti, 209, 535
- Racovitz, E. G., Note on the Great Sea Serpent, 287
- Radium Rays, Influence on Ova, 483
- — — on Tadpoles, 483
- Ramaley, F., *Egregiu Menziesii*, 635
- Ramè, —, Meckel's Diverticulum and Concomitant Absence of Cæcal Appendix, 710
- Ramularia æquivoca*, Development, 648
- Ransom, F., Researches on Tetanus, 661
- Rapidity and Numerical Aperture, 765
- Rapp, R., Rennet-like Enzyme from Yeast, 528
- Rat, Disease caused by Acid-fast Bacillus, 560
- Rats, Leprous Affection of Skin and Lymph-glands, 342
- Rauther, M., Genital Apparatus of Bats, 711
- Ravaud, —, French Moss Flora, 61
- Ravenelias of the United States and Mexico, 530
- Rayleigh, Lord, On the Theory of Optical Images, with Special Reference to the Microscope, 447

- Rayleigh, Lord, Supplementary Paper, 474
- Razor-Holder and Adjustable Clamp, New, for the Minot Microtome, 234
- Reagent Bottle, 558
- Red Corpuscles of Blood, Counting, 240  
— Rain, 682
- Reed, H. S., Development of Macrosporangium of *Yucca*, 312
- Reed, M., Two Marine Lichens, 537
- Reflectors, Fuess' Hemispherical Gypsum and Metal, 763
- Refraction, Specific Double, of Plant Tissues, 765
- Refractometer, Leiss' New Crystal, for the Determination of the Refractive Index of Large and Microscopically Small Objects, 226
- Regaud, C., New Microscopical Stand with Movable Stage capable of Large Movements, 670
- Regen, J., Stridulating Organs in Saltatorial Orthoptera, 296
- Regeneration in Limicolæ, 179  
— in Newts, 161  
— of Assimilating Mechanism in *Streptocarpus* and *Monophyllea*, 733  
— of the Body of a Star-fish, 616
- Regulating Arrangement, New, for Hot Stage, 669
- Reh, L., Statistical Study of Scale Insects on Fruit, 174
- Reichert, H., Fossil Diatoms, 635
- Reichert's Sliding Microtome, Improvement, 231
- Reinitzer, F., Disease of Apples, 529
- Reinke, J., Studies on the Comparative Development of Laminariaceæ, 526
- Reinsch, P. F., New Method for the Preparation of Horizontal Sections of Thin Laminated Vegetable Flat Tissues, 771
- Related Forms, Study, 207
- Remce, B., Specific Double Refraction of Plant Tissues, 765
- Renault, B., Fossil Infusorians, 306  
— Vegetative Activity in the Carboniferous Epoch, 513
- Rengel, C., Connection between Mid-Gut and Hind-Gut in Larval Hymenoptera, 720
- Reparation of Injury in Ceramiaceæ, 637
- Report of the Council for 1902, 122
- Reproduction, Asexual, 628  
— Vegetative, in *Chondria crassicaulis*, 330
- Reptiles and Amphibians, Biological Observations, 165  
— Optic Chiasma, 285  
— Structure of Digestive Canal, 163
- Reserve Carbohydrates of the Albumen of Palms, 49
- Resins, Gums, and other Vegetable Exudations of Australia, 50
- Respiratory Exchanges in Water, Study of, 600
- Reticular supporting Network of Malignant Neoplasm, Staining by Mallory's Method, 236
- Retina of Gastropod Eye, 168  
— of Vertebrates, Structure of the Outer Segments of Rods, 710
- Retterer, E., Fixing and Imbedding Dense Connective Tissue, 369  
— Transformation of Epithelium into Connective tissue, 597
- Retting of Flax and Hemp, 661
- Retzius, G., Spermatozoa of *Acanthias vulgaris*, 593
- Reuter, K., Staining Malaria Parasites with A-Methylen-Blue-Eosin, 108
- Rhabditis, Species, 180
- Rhabdopleura normanni*, Budding, 42
- Rheinberg, J., 250. 567  
— Common Basis of the Theories of Microscopic Vision without the Aid of Mathematical Formulæ, 102  
— Wide Illuminating Cones, 673
- Rhinocleroma Bacillus, Identity with Friedländer's Bacillus, 80
- Rhizobium, Motility, 540
- Rhizoctonia violacea*, 748
- Rhizoid-Initials of Marchantia, 58
- Rhizoids of Mosses, 627
- Rhizopod, New, 305
- Rhododermis, New, 636
- Rib Variation in Cardium, 718
- Ribaga, C., Insect against Insect, 294  
— New Hydrachnida and Ixodidæ from South America, 298
- Riccocarpus natans*, 323
- Richards, E., Chemical Composition of *Oscillaria prolifica*, 76
- Richter, P. P., Germination of Pollen Grains, 53
- Ridewood, W. G., New Genus of Copepod, 497
- Ridgeway, —. Origin of the Thoroughbred Horse, 711
- Ridgway, R., Birds of North and Middle America, 286
- Riella, 59, 522
- Riggs, E. S., Largest known Dinosaur, 287
- Rigler, G. v., Bacteriology of Natural Mineral Waters, 83
- Rinodina, 753
- Ritter, W. E., Heart of Enteropneusta, 42  
— Movements of Enteropneusta, 43
- Rivas, D., Anaerobic Cultivation, 104, 367
- Roberts-Austen, W. C., Certain Properties of the Alloys of the Gold-Silver Series, 375
- Robertson, A., Ascorhiza and Related Aleyonidia, 727  
— Embryonic Fission in the Genus *Crisia*, 726  
— Studies in Pacific Coast Entoprocta, 727

- Robertson, R. A., Functional Inertia of Plant-Protoplasm, 191
- Rochaz, G., Mosquitos in Winter, 606
- Rodella, —, Bacteria in Pus from a Gas-containing Abscess, 341
- Rodella, A., Presence of strictly Anaerobic Butyric Acid Bacilli and of other Anaerobic Species in Hard Cheese, 661
- Rodier, W., Rabbit-pest in Australia, 29
- Rodrigue, A., Anatomy and Movements of *Porliera hygrometrica*, 310
- Rogers, W. S., Protective Resemblance in Butterflies, 719
- Roland, L., Photography of Fungi, 76
- Röll, J., European Mosses, 198  
— German Mosses, 323
- Rolland, L., Poisoning by Fungi, 212
- Romanoff, B., Vital Staining of Microorganisms, 773
- Romanowski Stain, Modification, 680
- Romingeria, Genus, 729
- Röntgen and Ultra-Violet Rays, Sensitiveness of Ants to, 171
- Root-Development in Azolla, 520
- Root-Tubercles of *Medicago denticulata* and other Leguminous Plants, 217
- Rosa, D., Typical Chloragogen of Oligochaetae, 300
- Rose, T. K., Certain Properties of the Alloys of the Gold-Silver Series, 375
- Rosenberg, O., Fertilisation in Plasmopara, 745  
— Behaviour of the Chromosomes of Hybrids, 505
- Ross, L. S., New Colony Counter, 113
- Ross, R., Improved Method for the Microscopical Diagnosis of Intermittent Fever, 236
- Rosseter, T. B., *Drepanidotænia tenuirostris*, 499
- Rossi, G., Odoriferous Glands of *Julus communis*, 297  
— Structure of Myriopods, 177
- Rossi, G. de, Flagella Staining, 370
- Rössler, P., Minute Structure of Cysticerci, 182
- Rotatorian Genus *Diaschiza*, 1, 129
- Roth, G., European Mosses, 628
- Rothert, W., Spore-Development in Aphomyces, 641
- Rotifers, New Male, 183
- Roule, L., Hermaphroditism in Fishes, 282
- Rousselet, C. F., 117  
— Apparatus for Drawing Objects natural Size, 116  
— Exhibition of Mounted Rotifers, 376  
— Microscope used by Gosse, 118  
— New Pattern Microscope by Bausch and Lomb, 244
- Rowe, A. W., On the Photomicrography of Opaque Objects as applied to the Delineation of the Minute Structure of Chalk Fossils, 242
- Rowland, S., Intracellular Toxin of the Typhoid Bacillus, 217
- Rowley, F. R., Structure and Life-History of Diatoms, 525
- Rucker, A., New Species of *Koenenia*, 609
- Rubland, W., Fertilisation in the Phycomycetes, 68
- Ruppia, Life-History, 311
- Russell, W., Localisation of Daphnine in *Daphne Laureola*, 187
- Rust, Brown, of Bromes, Experiments, 72  
— on Vanilla, 72
- Rusts of Cereals, 648  
— of Leguminosæ, 531  
— of Plants, Problems in the Study, 531  
— of Special Natural Orders, 649  
— Researches, 72  
— Specialisation, 72
- Růžička, V., Structure of Red Blood-Corpuscles, 596
- S.
- Sablon, Leclerc du, Variation in Carbohydrate Reserves in Stem and Root of Woody Plants, 191
- Saccardo, P. A., Notæ Mycologicæ, 537
- Saccharomycetes and Bacteria, Cell-Nucleus, 68
- Sacs, Collodion, for Bacteriological Work, Simple Method of Making, 776
- Sagitta bipunctata*, Oogenesis and Spermatogenesis, 498
- Saint-Hilaire, C., Intestinal Epithelium in Amphiuma, 597
- Salamander, Land, Origin of Poison Glands, 713
- Salicin, Changes in Plant Nutrition, 517
- Salimbeni, A., La Garotilha, 756
- Salivary Glands, Endings of Nerves, 27
- Salmacina dysteri*, Development of Metameres, 613
- Salmon, E. S., Calytopogon, 196  
— Fossil Fungi, 534  
— Gooseberry Mildew in Europe, 335  
— Infection-Powers of Ascospores in Erysiphaceæ, 645  
— New Zealand Hepatics, 59  
— Notes on Erysiphaceæ, 206  
— Notes on Osculata and Schwetschkea, 60  
— Streptopogon, 196
- Salmon Disease, 755  
— Fertilisation, 160
- Salpa-Chain, New Type, 490
- Salt Solution, Influence on Early Development of Newt's Egg, 593  
— Water, Action on certain Fresh-water Algae, 203
- Salvin, O., Butterflies of Borderland between North and South America, 34
- Sanders, J. G., Notes on Erysiphaceæ, 335



- Sanger-Shepherd Process of Colour Photography, 121
- Sap-excreting Elements in *Tropæolum majus*, 733
- Saprolegnia, Oogenesis, 642
- Sarcina, Streptococcus and Spirillum, Observations, 540
- Saritz, R., Septoria, 338
- Saruthein, L. Graf, v., Lichen Flora of the Tyrol, 70
- Sauvageau, C., Australasian Sphaclariæ, 67
- Sayce, O. A., Australian Phyllopoas, 300
- Scab, in Sheep, 298
- Scale Insects on Fruit, Statistical Study, 174
- Scalia, G., New Disease of *Asclepius curassavica*, 748
- Scapania, 321
- Scatophaga, Male Organs, 607
- Scenedesmus acutus*, Morphology and Physiology, 525
- Sceptromyces Opizi*, 209
- Schaefer, F., Femoral Glands of Lizards, 27
- Schaffer, J., Decalcification Method, 558  
— New Glass Staining Trough, 371
- Scharif, R. F., Lost Atlantis, 715
- Schaudinn, F., Structure of Bacteria, 79
- Schauffler, W. G., Staining Diphtheria Bacilli and Cholera Vibrios, 235
- Scheffer, W., Improvements in the Vertical Microphotographic Camera, 101  
— Small Electric Light for Photomicrography, 95  
— Stereoscopic Photography of Microscopic Objects, 100  
— — Photomicrography with Weak Magnification, 674
- Schier, M., Identity of Rhinoscleroma Bacillus with Friedländer's Bacillus, 80
- Schenk, D., Antennary Sense-organs in Lepidoptera and Hymenoptera, 294
- Schewiakoff, W., Observations on Acanthometrea, 503
- Schiffner, V., Biography of K. G. Limpricht, 325  
— European Muscinæ, 197  
— Gymnomitrium and Marsupella, 743  
— Muscinæ of the Atlantic Islands, 62, 197
- Schilbersky, K., Moniliar Disease, 529
- Schinkewitsch, W., Development of *Telophonus caudatus*, 723
- Schimmelmannia ornata*, 527
- Schlater, G., Intranuclear Space in Liver-Cells, 162
- Schmid, B., Development of the Embryo of some Dicotyledons, 188
- Schmidle, W., Fresh-water Algæ, 629  
— Plankton of Lake Nyassa, 327  
— — and other Mid-African Lakes, 526
- Schmidt, H., Graphic Representation of the Correction Distance of an Objective, 762
- Schmidt-Nielsen, S., Autolytic Processes in Pickled Herring, 31  
— Psychophilic Bacteria, 79
- Schmitt, F., Gastrulation of Double-Development in Trout, 161
- Schneider, A., Motility of Rhizobium, 540
- Schneider, G., Bothriocephalus in the Baltic Herring, 615  
— Life History of *Bothriotænia proboscidea*, 42
- Schneider, K. C., Text Book of Comparative Histology, 26
- Schoenfeld, H., Fixation of Mammalian Egg in Uterine Cavity, 769
- Schoenemann, A., Staining and Preservation of Serial Sections on Paper Strips, 107, 371
- Schöndorff, A., Change of Colour in Trout, 713
- Schoute, J. C., System in Flowering Plants, 309
- Schrader, H. F., New Alaria, 636
- Schrammen, F. R., Effect of Temperature on Growing Cells, 507
- Schrötter, H., Staining Nervous Tissue with Gallein, 559
- Schuberg, A., Bottle for Immersion Oil, 777  
— Intercellular Connections, 487
- Schultze, B. S., Determination of Sex, 485
- Schultze, O., Determination of Sex, 705
- Schulz, O. E., Monograph of the Genus Cardamine, 626
- Schulze, F. E., Indian Triaxonia, 305
- Schuster, W., Bird and Man, 602
- Schute, T., German Flora, 519
- Schweikart, A., Chorion and Microphyle in Cephalopods, 168
- Schwendener, S., Opening Mechanism of Macrosporangia of Selaginella, 321  
— Spiral Arrangement in Florideæ, 66
- Schwer, —, Micro-organism infecting small Animals in the Laboratory, 342
- Schwetschkea and Osculatia, Notes, 60
- Sclerospora, 204, 332  
— Fertilisation, 642
- Scolorotinia Puckeliana*, 208
- Scolices, Production of Hydatid Cysts from, 42
- Scott, D. H., *Lagenostoma Lomaxi*, the Seed of Lyginodendron, 622  
— Primary Structure of certain Palæozoic Stems, 193
- Scott, T., Copepoda from Faroe Channel, 612
- Scourfield, D. J., Synopsis of British Fresh-water Cladocera, 497
- Screw-Worms in St. Lucia, 293

- Scriven, J. B., Preparing Serial Sections of Insects, 106
- Scyphomedusæ, N. American, 617
- Sea-Anemone and Crab, Commensalism, 728
- Sea Serpent, the Great, Notes on, 287
- Seaton, F., Compound Eyes of *Machilis*, 608
- Secretion and Absorption in Terrestrial Isopods, 39
- Secretary Apparatus, New, in Conifers, 621
- Secretary Canaliculi in Suprarenal Capsules, Method of Demonstrating, 235
- Sectioning Fresh Plant-Tissues, 231
- Sections, Celloidin, Improvements of Aubertin's Method for Sticking, 769
- Horizontal, of Thin Laminated Vegetable Flat Tissues, New Method for Preparation, 771
- of Leaf Cuticle, Manipulation, 770
- Paraffin, Simple Method of Making Thin, 105
- Serial, Method for the Investigation of Fossils, 775
- — of Insects, Preparing, 106
- Series of, Staining and Preservation on Paper Slips, 107
- Seed Leaves and Young Foliage Leaves, Protection, 51
- Seed-Coat in *Gentianaceæ*, Development and Structure, 622
- Seed-Germination, Influence of Light, 55
- Seedling of *Torreya Myristica*, 621
- Seeds, Destruction by Fungi, 644
- Fat-destroying Fungi, 534
- of *Ginkgo biloba*, Composition, 193
- of *Inga*, 513
- Production of Alcohol, 518
- Resistance to High Temperatures, 624
- Ripening, and Power of Germination, 315
- Segments, Intercalary, 722
- Selachians, Development of Teeth, 486
- Selaginella, Opening Mechanism of the Macrosporangia, 321
- Seligmann, C. G., New Method of Counting the Corpuscles of the Blood, 680
- Sellards, E. H., Palæozoic and Recent Cockroaches, 296
- Sematophyllum in N. America, 196
- Senecio, Monograph of North and Central American Species, 57
- Senescence and Conjugation in Infusorians, 503
- Sense-Organs, Antennary, in Lepidoptera and Hymenoptera, 294
- Integumentary of Deep-Sea Decapods, 299
- of *Ascaris*, 499
- Sensory Hairs on Pupa of *Papilio podalirius*, 175
- Septicæmia of Rabbits, Flagellated Micrococcus found in, 663
- Septoria, 337
- Serbinow, —, New Chytridiaceæ, 333
- Sergestes, New Species, 497
- Serial Sections, Apparatus for Quick and Uniform Staining and for Treatment of them in number with Reagents, 679
- — Application of the Cinematograph Principle to the Study, 776
- Setchell, W. A., Algæ of North-western America, 527
- Sex, Determination, 485, 705
- — of Gametes in Hermaphrodite Gonads, 32
- Sex-Cells in *Echinocardium cordatum*, Phagocytic Absorption, 727
- Sexual Organs, Interconversion in a Moss, 59
- Reproduction of Pteropcephalus, 729
- Sexuality of Ascomycetes, 644
- Shambaugh, G. E., Circulation in Labyrinth of Ear of Pig, 711
- Shark Sawfish, New Distomum, 500
- Sharp, D., Beetle Embedded in Wall of Human Intestine, 720
- Sheep, Estrous Cycle and Corpus luteum, 484
- Scab, 298
- Shelford, R., New Case of Protective Mimicry in a Caterpillar, 494
- Shellfish, Method of Detecting the Presence of *Bacillus coli communis*, 229
- Shells, Gastropod, Studies, 290
- Sherborn, C. D., Index Animalium, 598
- Sherlock, R. L., Foraminifera of Raised Reefs of Fiji, 306
- Shibata, —, Cytology and Physiology of Endophytic Mycorrhiza, 213
- Shinkishi, —, Efferent Neurons in Electric Lobes of Torpedo, 487
- Shufeldt, R. W., Classification of Birds, 286
- Shutter, Origin of the Davis, 99
- Siebenrock, F., Classification of Trionychidæ, 713
- Siedentopf, H., Engelmann's Microspectral Photometer with Grating Spectrum, 359
- on Rendering Visible of Ultra-Microscopic particles, and of Ultra-Microscopic Bacteria, 563
- Visibility of Ultra-Microscopic Particles, 228
- Siedlecki, M., New Coccidian, 185
- Phagocytic Absorption of Sex-Cells in *Echinocardium cordatum*, 727
- Resistance of *Gasterosteus aculeatus* to the Osmotic Pressure of Different Media, 714
- Rôle of Amœbocytes in *Polymnia nebulosa*, 724
- Silicious Spicules, 503
- Silk, Colour of, 35
- Moth, Artificial Parthenogenesis, 494
- Silphide, Alimentary Tract, 607

- Silvestri, F., A Most Primitive Insect, 295
- Simon, L., Notes on Development and Structure of *Bradypus*, 24
- Simroth, H., Phylogenetic Speculations, 166
- Recent Researches on Gastropods, 32
- Sin y, R. de, Acrosome of Spermatid of *Notonecta*, 295
- Development of Spermatid of *Notonecta glauca*, 295
- "Nebenkern" and Nuclein Movements in Spermatid of *Notonecta glauca*, 296
- Sinistral Snails, Breeding Experiments, 603
- Siphonae, New Genus of, 64
- Siphonophora, Flagellate Parasites, 306
- Sipunculids, Distribution and Affinities, 612
- Notes, 613
- Sk ats, A., Chemical Composition of Limestones, Microscopical Methods, 681
- Skin, Frog's, Permeability, 30
- of Trematodes, 500
- Skinner, S. A., Tide-Pool Vegetation, 639
- Skottsberg, C., *Myrocystis pyrifer*, 329
- Skrobansky, K. v., Yolk-Nucleus or Corpus Balbiani in Vertebrates, 485
- Slade, H. B., Hydrocyanic Acid in Sorghum, 517
- Sleeping Sickness, Etiology, 344
- — Trypanosoma found in, 504
- Slide for Pond Life, 239
- Slugs, Locomotion, 490
- Smell, Sense of in Snails, 290
- Smith, A., Lincolnshire Diatoms, 526
- Smith, A. L., *Sclerotinia Fucheliana*, 208
- Smith, B., Notes on Species of *Fulgur*, 32
- Smith, H. G., Leaf-Venation and Chemical Constituents of Eucalypts, 50
- Smith, R. G., New Gum Bacterium, 77
- Smith, W., Myrmecophily in *Macaranga triloba*, 625
- Smith, W. G., *Agaricus Henriettae*, 532
- Smith, W. H., Method for Staining Sputum for Bacteriological Examination, 372, 772
- Snails, Sense of Smell, 290
- Snake Venoms, 30
- Snakes, Anomalies in Head-Shields, 166
- Snow, L. M., Insects of the Drift Line, 33
- Soar, C. D., Exhibition of Drawings of British Freshwater Mites, 781
- Living Hydrachnid Larva in Trout's Stomach, 609
- Soil, Effect of Composition on Plants, 190
- Solenogastres, New, 717
- Solger, B., "Intracellular Threads" in Ganglion-Cells of Electric Organ of Torpedo, 162
- New Freezing Plate for Hand Microtome, 558
- Sollas, W. J., Method for the Investigation of Fossils by Serial Sections, 775
- and I. B. J., Palaeospondylus, 714
- Soluble Glass as Mounting Medium for Examination of Paper, 774
- Sorbus Aucuparia*, Disease, 335
- Sorghum, Hydrocyanic Acid, 517
- Sosnowski, J., Physiological Study of Metamorphosis, 172
- Soulier, A., Revision of Annelids of the Cete Region, 498
- Sparrow, Spermatogenesis, 23
- Specific Gravity of Cell-Sap, 186
- Spelerpes longicaudus*, Development of Musculature and Skeleton, 595
- Speller, F. N., New Etching Reagent for Polished Steel Sections, 682
- Spermatid of *Notonecta*, Acrosome, 295
- of *Notonecta glauca*, Development, 295
- — — "Nebenkern" and Nuclein Movements, 296
- Spermatogenesis and Oogenesis in *Sagitta bipunctata*, 498
- — of *Cyclops strenuus*, Maturation Phenomena, 39
- in Cephalopods, 717
- in *Cybister roeselii*, 36
- in Drones, 719
- in Hydra and Aurelia, 304
- in *Phalangista vulpina*, 24
- in Sparrow, 23
- of Locustidae, 37
- Spermatozoa, Dimorphic, in Butterflies, 605
- Dimorphism, 23
- of *Acanthus vulgaris*, 593
- Spermatozooids, Development in Marchantia, 741
- Sphaecelariaceae, Australasian, 67
- Sphaecarpus terrestris*, 522
- Sphaeropsidaceae, New, 69
- Sphagna and Hepatics, German, 322
- of Upper Teesdale, 523
- Sphagnum, Leaf-cells, 197
- Spherulin, Distribution among Plant Families, 309
- Spiders, Copulation, 609
- German, Monograph, 38
- of Germany, 497
- Spieß, C., Alimentary Tract of the Leech, 302
- Minute Structure of the Alimentary Canal of the Leech, 612
- Spindle Formation, Studies, 731
- Residues in Cell-Division, 162
- Spine, Curvature in Fishes, 161
- Spinelli, V., Marine Algae of Sicily, 638
- Spintharoscope, 563
- Spiral Arrangement in Florideae, 66
- Spirillum, Sarcina, and Streptococcus. Observations, 540

- Spirogyra, Nuclens, 48  
 Spitta, E. J., Arrangement for Obtaining Monochromatic Light with the Mixed Jet, 15  
 Spleen, Hæmatolytic Function, 30  
   — in *Tropidonotus natrix*, Development, 485  
 Sponges, Calcareous, from Pacific, 729  
   — Metabolism, 304  
   — Pacific Horny, 729  
*Spongilla fragilis*, Note, 502  
 Spore Characters, 212  
 Spore-Development in Aphanomyces, 641  
 Spore-formation and Nuclear Behaviour in *Hydnangeum carneum*, 750  
   — in Bacteria, Physiology, 339  
   — in Gastromycetes, 211  
   — in Mucorini, 745  
   — in Yeast, 68  
 Spore-producing Members, Morphology; General Comparisons and Conclusions, 318  
 Spore-Ripening and Fertilisation in Mosses, 522  
 Spores of Bacteria. Antibodies, 218  
   — of Vaucheria, 631  
 Sporocysts, Two Remarkable, from *Mytilus latus*, 726  
 Sporophyte, Origin, 640  
 Sprouting of Yeast-Cells, 68  
 Sputum, Demonstration of Tubercle Bacilli, 767  
   — Method for Staining for Bacteriological Examination, 372, 772  
 Squid, Vascular System, 31  
 Srdinko, O. V., Structure and Development of Cartilage, 163  
 Stabler, G., British Hepaticæ, 742  
 Stafford, J., American Representatives of *Distomum cygnoides*, 182  
   — American Representatives of *Distomum Variegatum*, 41  
 Stage, An Improved Horseshoe, 591  
   — and Limb of Watson's Van Heurck Microscope, Method of Fitting, 88  
   — Koristka's Mechanical, 547  
   — Mechanical, capable of Large Movements, and New Microscopical Stand, 670  
   — — Watson's New Attachable, 779  
   — — Watson's New Sköp, 669  
   — Tomes', 245  
   — Watson and Sons' Attachable Mechanical, 89  
   — Watson's "Argus" Attachable Mechanical, 761  
 Stäger, R., Infection Experiments with Claviceps, 746  
 Stain, Differential, of *Bacillus Diphtheriæ*, 370  
 Staining and Mounting Urinary Sediment, 560  
   — and Preservation of Serial Sections on Paper Strips, 371  
 Staining Bacterial Granules, Method, 371  
   — — — New Method, 237  
   — Diphtheria Bacilli and Cholera Vibrios, 235  
   — Directions for Photomicrography, 234  
   — Flagella, 370  
   — — — New Method, 235  
   — — of Bacteria, Easy Method, 237  
   — Medullary Sheath, Use of Paraffin Imbedding, 771  
   — Methods, Two Botanical, 772  
   — Modification of the Uranium Carmine of Schmaus, 773  
   — Nervous Tissue with Gallein, 559  
   — Reactions of Proteid Crystals, 236  
   — Reticular supporting Network of Malignant Neoplasms by Mallory's Method, 236  
   — Serial Sections, Quick and Uniform, Apparatus for, and for Treatment of them in Number with Reagents, 679  
   — Sputum for Bacteriological Examination, Method, 372, 772  
   — Streptotrichaceæ, 541  
   — Thermophore, 774  
   — Vital, Micro-organisms, 773  
   — — of Blood-plates in Man with "Brilliantkresylblau," 773  
   — with Ehrlich Triacid Solution, Modification of the Method, 560  
 Staining-Trough, New Glass, 371  
 Stand, Leitz' New, and Fine Adjustment, 665  
*Stappia cylindrica*, 630  
*Staphylococcus pyogenes aureus*, Resisting Powers, 541  
 Starbäck, K., Xylariæ of South America, 335  
 Starch-Grain, Structure, 507  
 Starch-Grains in Root-Cap of Onion, 508  
 Starfish Ova, Experiments, 501  
   — Regeneration of the Body, 616  
 Starlinger, J., Improvement in Reichert's Sliding Microtome, 231  
 Statocysts in an Isopod, 610  
   — of Cephalopods, 716  
 Statolith Theory of Geotropism, 515  
 Steam, Superheated, Effect upon Tensile Strength of Alloys, 683  
 Stebbing, E. P., Economic Entomology, 721  
 Stebbins, J. H., jun., Stain for Elastic Fibres, 109  
 Steel, Crucible, The Microscope in the Manufacture, 682  
   — Sections, Polished, New Etching Reagent, 682  
   — Simultaneous Presence of Ferrite and Cementite, 683  
 Steel-Works Materials, Analysis, 375  
 Stefanow-ska, M., Growth in Weight of White Mice, 489  
 Stefansky, —., Leprous Affection of the Skin and Lymph-Glands of Sewer Rats, 342

- Steinbrinck, C., Permeability of Cell-walls to Air, 194
- Steiner, J., Lichen Flora of Algiers, 71
- Steinheil and Voit's 'Handbuch der Angewandten Optik,' 102
- Stelar System in Flowering Plants, 309
- Stele, Unipolar, in Rootlets of *Trapa*, 509
- Stem, Distribution of Hairs on Surface, 52
- Foliar Origin, 508
- in Magnoliaceæ, Comparative Anatomy, 51
- of *Derris uliginosa*, Poisonous Action and Histology, 520
- Stereoscopic Photography of Microscopic Objects, 100
- Photomicrography, New Device, 223
- — with Weak Magnification, 674
- Sterigmatocystis niger*, Culture, 651
- — Nutrition, 338
- *pseudonigra*, 338
- Sterilisable Hypodermic Syringe, New, for Aseptic and Bacteriological Injection Experiments, 680
- Sterzi, G., Blood-Vessels of the Spinal Cord of Birds, 487
- Stevens, F. L., Fertilisation in *Sclerospora*, 642
- *Sclerospora*, 332
- and A. C., Mitosis in *Synchytrium*, 620
- Stevens, N. M., Experimental Studies on Eggs of *Echinus microtuberculatus*, 501
- Oogenesis and Spermatogenesis in *Sagitta bipunctata*, 498
- Stiasny, G., Kidney of *Helix pomatia*, 290
- Stigeoclonium, Young Plants, 201
- Stigmalaria, 521
- Stiles, C. W., Asiatic Human Parasites, 302
- Vinegar Eel in Human Bladder, 40
- Stirton, J., and others, British Mosses, 523
- Stomach, Embryonic Circulation, 595
- Stomata of Cotyledons, 515
- Stoney, G. J., 564
- Improved Heliostat, 92
- 'Note' on Lord Rayleigh's paper of 1896, 783
- Stopper of Fusible Metal for Test-Tubes, 240
- Storing-Kidney in *Carinaria mediterranea*, 717
- Strasser, P. P., Fungus Flora of Sonntagberg, 73
- Streeter, G. L., Use of Paraffin Imbedding for Medullary Sheath Staining, 771
- Streptocarpus and Monophyllæa, Regeneration of Assimilating Mechanism, 733
- Streptococcus, Sarcina, and Spirillum, Observations, 540
- Streptopogon, 196
- Streptothrix, 215
- Streptotrichaceæ, Staining, 541
- Stridulating Organs in Saltatorial Orthoptera, 296
- Stridulation of Death's-Head Moth, 34
- Stringer, E. B., On a New Method of Using the Electric Arc in Photomicrography, 276, 377
- Striped Muscle-Cell of *Neecturus*, Nuclear Changes, 27
- Strobell, E. C., Cocoons of Earthworm, 40
- New Method of Focussing in Photomicrography, 677
- Sperm Centrosome and Aster of *Allolobophora fœtida*, 724
- Strong, W. M., New Method of Counting the Corpuscles of the Blood, 680
- Stschelkanootzeff, J. P., Segments of Pseudoscorpionidæ, 298
- Stummer-Traunfels, R. Ritter v., Fresh-water Polyelad, 182
- Stylopidæ, Development, 494
- Styracæe, Notes, 57
- Subradula Organ in Chiton, Function, 492
- Sugar in Ripe Fruits, 192
- Sugar-free Bouillon, Method of Preparing, 767
- Sulphur-Bacteria, New Group, 540
- Suprarenal Capsules, Intracellular Canaliculi, 597
- — Method of Demonstrating the Secretory Canaliculi, 235
- — Secretory Processes, 709
- Suzuki, S., Action of Potassium Iodide and Potassium Ferrocyanide, 518
- Suzuki, U., Composition of Seeds of *Ginkgo biloba*, 193
- Formation of Asparagine in Metabolism, 192
- Svedelius, N., Marine Algæ from Dago, 67
- Swim-Bladder, Comparative Embryology, 708
- Swingle, D. B., Spore-Formation in *Mucorina*, 745
- Sycandra raphanus*, Ingestion of Food Particles, 304
- Sydow, H. and P., *Asterconium Saccardoii*, 337
- Monograph of the Uredineæ, 72
- Notes on Nomenclature, 651
- *Fillelia abscondita*, 650
- Symmetry, Inverse, Cause, 706
- Synchytrium, Mitosis, 620
- Syncoryne sarsii*, Minute Structure, 44
- Syringe, New Sterilisable Hypodermic, for Aseptic and Bacteriological Injection Experiments, 680

## T.

- Tadpoles, Influence of Radium Rays on, 483
- Taka Diastase, Effects of Chemical Agents on Starch-converting Power, 517
- Takahasi, T., Production of Alcohol in Seeds, 518
- Takahashi, Y., *Ustilago Panicis miliucei*, 210

- Tammes, T., Periodicity of Morphological Phenomena in Plants, 515
- Tandler, J., Structure of Gecko's Toes, 712
- Tassi, F., New Spheropsidæ, 69
- Taste-Fibres, Course, 286
- Tavares, J. da S., Studies on Zoococcidia, 38
- Taverner, H., Photographs of Images seen in Binocular Microscope, 783
- Taxodium, Gametophytes and Embryo, 734
- Taylor, L., Asiatic Human Parasites, 302
- Teeth in Selachians, Development, 486
- of Diptera, 606
- Teichert, K., Fungi in Dairy Products, 534
- Teleosts, Optic Chiasma in, 287
- "Telescopic" Eye, So-called, of some Abyssal Fishes, 164
- Teliospores, Germination, 210
- Tellyesniczky, K., Criticism of Theories of Nuclear Structure, 27
- Telyphonus caudatus*, Development, 723
- Temperature, Effect on Growing Cells, 507
- of the Tunny, 600
- Temperatures, High, Resistance of Seeds, 624
- Teratology, Plant, 58
- Termites, Termitophils and Myrmecophils, New, 172
- Termitophils, Termites and Myrmecophils, New, 172
- Terras, J. A., New Upright Photomicrographic Apparatus, 224
- Testis and Ovary, Mammalian, Embryonic Development, 706
- Test-tubes, Fusible Metal Stopper, 240
- Tetanus Bacillus, Observations on the Flagella, 663
- Researches, 661
- Texas Fever, Parasite, 618
- Thalassanid, Rare, and its Larva, 611
- Thamniun, 742
- Genus, 60
- Thaxter, —, New England Choanephora, 642
- Thaxter, R., Laboulbeniaceæ, 70
- New Hyphomycetes, 529
- Notes on Monoblepharis, 640
- Theriot, I., Mosses of Alaska, 324
- Thermophore for use in Staining, 774
- Thermostat, New Economical, of Simple and Light Construction, 678
- Thesing, C., Spermatogenesis in Cephalopods, 717
- Thibaut, F., 205
- Thiele, J., Insufficiently Described Monaxonia, 729
- Thienemann, A., Statocysts in an Isopod, 610
- Thigmotropic Root-Curvatures, 192
- Thilo, O., Skeletal Changes in Flat-Fishes in the Course of Development, 25
- Thimfeldia, American Species, 738
- Thiophysa volutans*, 754
- Thompson, M. T., Rare Thalassinid and its Larva, 611
- Thor, S., Thick-skinned Acarina, 177
- Thorns of *Gleditschia triacanthos*, 51
- Thouvenin, M., Petiolar Glands of *Viburnum opulus*, 510
- Threads, Intracellular, in Nerve-Cells, 596
- Thrips, Injurious Influence on Man, 174
- Throwing-Net and Mud-Sucker, 167
- Thuja, Morphological Study, 189
- Thysanura, Studies, 295
- Tichomiroff, A., Artificial Parthenogenesis in Silk Moth, 494
- Tide-Pool Vegetation, 639
- Tilletia abscondita*, 650
- Timbers, Indian, Manual, 52
- Tissier, —, Putrefaction of Meat, 218
- Tissier, H., Researches on the Fermentation of Milk, 756
- Tobler, F., Germination of certain Floridææ, 331
- Polymorphism of Marine Algæ, 636
- Reparation of Injury in Ceramiaceæ, 637
- Vegetative Reproduction of *Dasya elegans*, 66
- Tomes' Stage, 245
- Tompa, A. V., Two Botanical Staining Methods, 772
- Tonkoff, W., Development of Spleen in *Tropidonotus natrix*, 485
- Influence of Salt Solution on Early Development of Newt's Egg, 593
- Tonzig, C., New Economical Thermostat of Simple and Light Construction, 678
- Top-ent, E., Asterosteptidæ, 729
- Törnquist, S. L., Studies on Graptolites, 184
- Torpedo, Efferent Neurons in Electric Lobes, 487
- "Intra-cellular Threads" in Ganglion-Cells of Electric Organ, 162
- Torre, K. W. v. D., German Flora, 519
- Torrend, C., Fungi of the Setubal Region, 73
- Torrey, H. B., Hydroids of Pacific Coast of North America, 44, 502
- Notes on Anemones and Variation in Metridium, 45
- Prepotency in Polydaetylous Cats, 24
- Torreya Myristica*, Seedling, 621
- Torsion of Bird-Embryo, 161
- Tortoise, Asiatic, Parasites, 46
- Totzauer, R. J., Relations of Kidneys and Gonads in Haliotis, 170
- Tower, W. L., Coloration of Coleoptera, 720
- Development of Wings in Beetles, 293
- Exuvial Glands in Insects, 173
- Toxin, Intracellular, of Typhoid Bacillus, 217
- Toxotes jaculator* in Captivity, 30
- Toyama, —, Bacterium Pathogenic for House-Rats, 341
- Tracheal Gills on Legs of Larval Perlid, 607

Trachelomouas, New Species, 504  
 Tracheopulmonate Gastropods, 291  
 Transpiration, Use of Collodion for Detecting, 514  
 Trapa, Unipolar Stele in Rootlets, 509  
 Traverso, G. B., Sclerospora, 204, 332  
 — Stomata of Cotyledons, 515  
 Treadwell, A. R., Artificial Parthenogenesis in Egg of *Podarke obscura*, 498  
 Treasurer's Account, 1902, 125  
 Tremataspis, Appendages, 714  
 Trematodes from Marine Turtles, 41  
 — North American, 41, 303  
 — Notes, 500  
 — Skin, 500  
 Trenel, —, Agglutination, 78  
*Trepomona agilis*, Structure, 306  
 Treub, M., Embryogeny of *Ficus hirta*, 313  
 Triacid Stain, Fixation of Blood-Films, 229  
 Triaxonia, Indian, 305  
 Triceratium, Minute Structure, 62  
 Trichodectidæ, North American, 722  
*Trichoglaea lubrica*, 637  
 Trichomes in Myrsinaceæ and Fruit of *Jacquinia ruscifolia*, 189  
 Trillium and Paris, Nuclear Reduction and Fertilisation, 48  
 Trionychidæ, Classification, 713  
*Triplotenia mirabilis*, 181  
 Tripylea, New, 45  
*Triton blasii*, Hybrid Nature, 707  
 Trochanter and Præfemur, 175  
*Tropæolum majus*, Sap-excreting Elements, 733  
 Trophospongia, 162  
 — in Glandular Cells, 596  
 Trophospongium of Nerve-Cells and Pancreatic Cells, 26  
*Tropidonotus uatrix*, Development of Spleen, 485  
 Trouessart, E., *Gamasus auris*, 177  
 Trout, Change of Colour, 713  
 — Gastrulation of Double-Development, 161  
 Trout's Stomach, Living Hydrachnid Larvæ, 609  
 Truffaut, G., Nutrition of Chrysanthemums, 737  
 Truffles, Cultivation, 643  
 Trypanosoma found in Sleeping Sickness, 504  
 Trypanosomas from Transvaal Cattle, 46  
 Trypanosomata, Demonstrating, 371  
 Trypanosomes, Detection, 775  
 Trypanosomiasis, 307  
 — of Horses in the Philippines, 619  
 Tsiklinsky, —, Thermophilous Bacteria, 539  
 Tubercle Bacilli in Sputum, Demonstration, 767  
 Tuberculosis in Plants, Physical Conditions, 54  
 Tubeuf's Drawing Apparatus, 763

Tulip and Crocus, Movement of Perianth Leaves, 191  
 Tumours, Embryology, 705  
 Tunny, Temperature, 600  
 Turbellarian, New, 41  
 Turf-Pits, Conifer Wood from the, 50  
 Turner, E. R., 'On a new Arrangement for taking Photomicrographs in Colours,' 118  
 Turquet, J., *Amylomyces Rouxii*, 68  
 Turtle, Snapping, New Monostome from, 615  
 Turtles, Marine, Trematodes from, 41  
 Two-speed Fine Adjustment, 19, 117  
 Typhoid Bacillus, Immunising Effects of Contents, 541

## U.

Uffenheimer, A., *Bacillus aerogenes aerophilus agilis*, 81  
 Ulotrichaceæ and Chætophoraceæ of United States, 65  
 Ultra-Microscopic Particles and Ultra-Microscopic Bacteria, On the Rendering Visible of, 573  
 — — — Visibility, 228  
 Ultra-Violet and Röntgen Rays, Sensitiveness of Ants to, 171  
 — Radiations, Bactericidal Action, 756  
 Umbilicaria in North America, 71  
 Underwood, L. M., Botrychium, 320  
 — Cuban Ferns, 58  
 — Ferns and Fern Allies of N. America, 195  
 — Riella, 522  
 Unna, P. G., Ink for Writing on Glass, 112  
 Uranium, Action on Plants, 518  
 — Carmine Staining of Schmaus, Modification, 773  
 Uredineæ, 530  
 — Changes produced in Peridial Cell-Walls, 749  
 — Clamp-Connections and Fusion, 750  
 — Cultures, 210, 530  
 — Monograph, 72  
 — Nomenclature, 650  
 — Notes, 749  
*Uredo bistortarum*, 210  
 Urinary Sediment, Staining and Mounting, 560  
 Uromyces, New or Critical Species, 531  
 — of Lupinus, 650  
*Urophlyctis bohémica*, 204  
*Ustilago Paucii miliaeci*, 210  
 Uterine Cavity, Fixation of Mammalian Egg, 769

## V.

Vaillant, L., Fresh-water Fishes of Borneo, 289  
 Vaillard, L., Bacillus of Epidemic Dysentery, 659

- Valenti, G. L., Easy Method of Staining the Flagella of Bacteria, 237
- Valonia, Reproduction, 64
- Valoniaceæ, New Genus, 201
- Vaney, C., Budding of *Rhabdopleura normanni*, 42
- Dipterous Parasite of the Vine-pest *Haltica*, 606
- *Entosiphon Deimatis* Parasitic in an Abyssal Holothuroid, 491
- Nuclear Emissions in Protozoa, 305
- Vanilla, Diseases, 70
- Rust, 72
- Varanus niloticus*, Adaptations to Molluscivorous Diet, 712
- Vaschide, —, Vital Rhythm, 28
- Vascular System of Amphioxus, 489
- of Squid, 31
- Tissue, Evolution, 187
- Vasiform Orifice of Aleurodidæ, 721
- Vaucheria, Spores, 631
- Vaupel, F., Morphology of Muscinæ, 627
- Vayreda, —, Plants of Catalonia, 318
- Vegetable, Thin Laminated Flat Tissues, New Method for Preparation of Horizontal Sections, 771
- Vegetative Activity in the Carboniferous Epoch, 513
- Vein, Perforation by Artery in Cat, 711
- Venom of Serpents, Sap of Fungi as an Antidote, 76
- Verboeff, K. W., Innervation of Metacephalic Segment, 34
- Intercalary Segments, 722
- Systematic Position of Hemimerus, 607
- Trochanter and Præfemur, 175
- Verrill, A. E., Bermuda Islands, 626, 716
- Verschaffelt, E., Prussic Acid in opening Buds of Prunus, 516
- Vertebral Column of Penguin, Development, 283
- Vetebrata, Amitotic Division, 595
- Vertebrates, Comparative Anatomy, 28
- Homology of *Lagena*, 710
- Structure of Outer Segments of Rods in Retina, 710
- Treatise on Comparative and Experimental Embryology, 160
- Yolk-Nucleus or Corpus Balbiani, 485
- Verworn, M., Biogen-Hypothesis, 285
- Vestergren, T., *Micromycetes rariores selecti*, 535
- and others, New Records of Fungi, 655
- Vestigial Function, 160
- Vevey, S., Artault de, Injurious Influence of Thrips on Man, 174
- Vezey, J. J., 116, 117, 120, 127, 243, 378
- Viala, P., *Bornetina Corium*, 650
- "Phthiriose," a Disease of the Vine, 531
- Viburnum Opulus*, Petiolar Glands, 510
- Vignier, C., Artificial Parthenogenesis, 22
- Villaggio, —, Wide Illuminating Cones, 673
- Villard, J., Cellular Nature of Zoochlorellæ, 597
- Vine Disease, 334
- — "Phthiriose," 531
- Vine, Leaves, Morphological Variation as a consequence of Grafting, 738
- Perforation, 71
- Vinegar Eel in Human Bladder, 40
- Visual Purple, 766
- Vital Rhythm, 28
- Staining of Micro-organisms, 773
- Vitality, Electrical Criterion, 599
- of Yeast, Observations, 646
- Vitreous Humour, Development and Structure, 163
- Vogel, —, Nitrogen-fixing Bacteria, 540
- Voges, O., Parasite of a Central South American Horse Disease, 619
- Vogler, P., Variations-Statistics as applied to Plankton-Diatoms, 63
- Vogolino, P., Development of *Ramularia æquivoca*, 648
- *Polydesmus exitiosus* and *Alternaria Brassicæ*, 338
- Septoria, 337
- Voisin, D. N., Dimorphic Spermatozoa in Butterflies, 605
- Nature of the Centrosome, 283
- Spermatogenesis in *Cybister ræselii*, 36
- Volcanic Dust, Microscopic Appearances, 374
- Voltzenlogel, E., Hind-End of Asearis, 180
- Volvox, Phototaxis, 730
- Vorges, D. de., Utilisation of Carbonate of Lime by Anodonta, 718
- Vorticellid, New, 504
- Vosmaer, G. C. J., Silicious Spicules, 503
- Voss, W., Clamp-Connections and Fusion in the Uredinæ, 750
- Vosseler, F., Structure of Intestinal Villi, 164
- Vosseler, J., Chemical Defence and Other Adaptations in North African Orthoptera, 174
- Vuillemin, P., Bacteriophagous Acrasidæ, 752
- Intermediate Wood, 309
- Study of *Absidia*, 333
- Zygosporos of Mucorini, 746
- Vurpas, C., Vital Rhythm, 28

## W.

- Wagner, F., Variations of *Pieris napi*, 493
- Wagner, F. v., Parasitism among Animals, 487
- Wagner, R., *Lagochilus*, 52
- Notes on Compositæ, 513
- Walk, G. v., Specific Gravity of Cell-sap, 186
- Walker, A. O., Antarctic Amphipods, 611
- Wallaby, Parasite, 294



- Wallace, W., Ovarian Ova and Follicles in Fishes, 594
- Waller, A. D., Electrical Criterion of Vitality, 599
- Wandolleck, B., Appendicular Nature of Abdominal Styles, 175
- Ward, H. M., *Puccinia dispersa* and its adaptive Parasitism, 649
- Ward, M., Effect of Mineral Starvation on the Parasitism of *Puccinia*, 210
- Warnstorf, C., European *Harpidia*, 195
- German Hepatics and *Sphagna*, 322
- Wasmann, E., Guests of the *Dorylinæ*, 172
- New Termites, Termitophils, and Myrmecophils, 172
- Pseudogyny in *Formica*, and its Cause, 172
- Water and Aqueous Solutions, Effects on Foliage Leaves, 315
- Water-Bloom, 658
- Watson and Sons' Attachable Mechanical Stage, 89
- Incandescent Gas Lamp, 92
- Macro-Illuminator, 91
- Metallurgical Microscope, 86
- Museum Microscope, 88, 379
- Stand Condenser, 379
- Watson, W. F., Photography by Natural Lenses, 764
- Watson's "Argus" Attachable Mechanical Stage, 761
- New Pattern Portable Microscope, 670
- — Sköp Mechanical Stage, 669
- — Standard Electric Lamp, 95
- Van Heurck Microscope, Method of Fitting Stage and Limb, 88
- Watts, W. W., Moss Flora of Australia, 524
- Wax-making Organ of Bee, 719
- Weber, A., Torsion of Bird-Embryo, 161
- Weber, M., History of the Fauna of the Indo-Australian Archipelago, 598
- Wedekind, W., Vestigial Function, 160
- Weems, J. B., Diseases of Grasses, 751
- Weeping Trees, Influence of Loading on the Formation of Wood and Bast Elements, 192
- Weevers, T., Changes in Silicin in Plant Nutrition, 517
- Wehmer, C., Decomposition of Lactic Acid by Fungi, 534
- Mucorini, 333
- Weichselbaum, A., Cultivation of Anaerobic Bacteria, 340
- Weight, Growth in, of White Mice, 489
- Weisia sterilis*, 742
- Weismann, A., Regeneration in Newts, 161
- Werner, F., Biological Observations on Reptiles and Amphibians, 165
- Wesché, W., 244, 781
- Male Organs of Scatophaga, 607
- New Male Rotifers, 183
- Wesché, W., On the Mouth-parts of the Nemocera and their relation to the other families in Diptera, 785
- Parasite of the Wallaby, 294
- Wesenberg-Lund, C., Relict Fauna of Lake Furesö, 289
- Wesselingh, C. v., Nucleus of *Spirogyra*, 48
- West, W., *Debarya immersa*, 201
- and G. S., British Fresh-water Algæ, 326
- — Fresh-water Algæ of the North of Ireland, 202
- Westerlund, C. A., Synopsis of Palearctic Forms of *Clausilia*, 492
- Weysse, A. W., Perforation of a Vein by an Artery in the Cat, 711
- Wheldon, J. A., British Hepaticæ, 198
- — Moss Flora, 60
- White, D., Fossil Algæ, 203
- — — from North America, 639
- Whitelegge, T., Moss Flora of Australia, 524
- Whitney, W. R., Microscopic Examination of Paper Fibres, 111
- Wiedersheim, R., Comparative Anatomy of Vertebrates, 28
- "Larynx" of Ganoids and Dipnoi, 600
- Wiedersheim, W., Influence of Loading on the Formation of Wood and Bast Elements in Weeping Trees, 192
- Wiedman, S., Note on the Amphibole Hudsonite previously called a Pyroxene, 777
- Wijhe, J. W. v., Method for Demonstrating Cartilaginous Micro-Skeletons, 372
- Wiley, H. W., Agriculture and Bacteria, 84
- Apparatus for Collecting Samples of Earth for Bacteriological Examination, 104
- Will, H., Observations on the Vitality of Yeast, 646
- Yeast-forms of Fungi, 747
- Wille, N., Algological Notes, 630
- Fresh-water Algæ from Zambesi, 327
- Williams, L. W., Vascular System of Squid, 31
- Williams, R. S., *Psilopilum*, 325
- Williams, S. R., Variation in *Lithobius forficatus*, 608
- Williamson, N. E., Trypanosomiasis of Horses in the Philippines, 619
- Wilson, A., British Hepaticæ, 198
- — Moss Flora, 60
- Wilson, J. T., Early Stages in Development of *Ornithorhynchus*, 282
- Wiltshire, Rev. Thomas, 159
- Wings in Beetles, Development, 293
- of *Naucoris cimicoides*, Normal Asymmetry, 174
- Winiwarter, H. v., Note on Oogenesis in Mammals, 22
- Wintrebert, P., Influence of Central Nervous System on Development of Limbs in Amphibians, 594

- Wolf, A., Influenza-like Bacillus from a Rat, 342  
 Wolf, H., Simple Method of Making Thin Paraffin Sections, 105  
 Wolterstoff, W., Hybrid Nature of *Triton blasii*, 707  
 Wood, Histology in Species of Pine, 188  
 — Intermediate, 309  
 Woodman, A. G., Microscopic Examination of Paper Fibres, 111  
 Woodward, H., President's Address: 'Some Ideas on Life,' 142  
 Woody Plants, Abnormal Growths, 511  
 Woolley, P. G., Staining the Reticular supporting Network of Malignant Neoplasms by Mallory's Method, 236  
 Worms, Parasitic as Aids in Zoogeographical Investigation, 40  
 Worsdell, W. C., Abnormal Flowers of *Helonium autumnale*, 623  
 — Evolution of Vascular Tissue, 187  
 Wright, —, 247  
 Wright, C. H., Flora of China, 519  
 Wright, E. P., *Bryopsis plumosa*, 329  
 — *Mustogloia fimbriata* and *M. binotata*, 329  
 Wygaerts, —, Reconstitution and Formation of Chromosomes in Somatic Nuclei, 505
- X.
- Xylariæ of South America, 335
- Y.
- Yabe, Y., East Asiatic Pteridophyta, 740  
 Yeast, 205  
 — Action on Albumen, 647  
 — and Animal Cells, Study of Nuclei, 205  
 — Cytology, 205, 335, 646  
 — Development in Sugar Solution without Fermentation, 337  
 — Ferment, 56  
 — Forms, &c., 646  
 — Forms of Fungi, 747  
 — Glycogen from, 49  
 — Observations on Vitality, 646  
 — Origin, 68  
 — Rennet-like Enzyme, 528  
 — Spore-formation, 68  
 Yeast-Cells, Sprouting, 68  
 Yeast-Spores, Formation, 336
- Yeasts, Assimilation, 55  
 — Life-History, 205  
 Yendo, K., Eisenia and Ecklonia, 329  
 Yolk-Nucleus or Corpus Balbiani in Vertebrates, 485  
 Young, W. J., Glycogen from Yeast, 49  
 Yucca, Development of Macrosporangium, 312  
 Yung, E., Sense of Smell in Snails, 290
- Z.
- Zachariades, P. A., Axial Filament in the Adult Connective-Tissue Fibril, 596  
 Zacharias, O., *Achromatium oxaligerum*, 755  
 — *Carterius stepanowi*, 617  
 — New Turbellarian, 41  
 — Throwing-Net and Mud-Sucker, 167  
 Zahlbrückner, A., Brazilian Lichens, 753  
 — Californian Lichens, 71  
 — Lichen Flora, 753  
 Zamia, Embryogeny, 310  
 Zander, E., Gill-Filters of Fresh-water Fishes, 714  
 — Male Genital Appendages in Lepidoptera, 605  
 Zanfrognini, C., Lichen-Flora, 209  
 Ziegler, H. E., Influence of Alcohol on Development, 484  
 Zielleczkey, R., Differentiation of *Bacillus coli* and *Bacillus typhosus*, 367  
 Zietzschmann, E. H., Integumentary Organs of Cervidæ, 284  
 Zimmermann, C., Plant Microscopy, 58  
 Zolnitsky, N., *Toxotes jaculator* in Captivity, 30  
 Zoococidia, Studies, 38  
 Zoochlorellæ, Cellular Nature, 597  
 Zoology, Historical Aspects, 487  
 — Text-books, 166  
 Zopf, W., Products of Metabolism in Lichens, 537  
 Zschokke, F., Marine Parasites in Fresh-water Fishes, 499  
 — New Case of *Dipylidium caninum* in Man, 499  
 Zsigmondy, R., Visibility of Ultra-Microscopic Particles, 228  
 Zygomorphism, Floral, Cause, 52  
 Zygosporos of Mucorini, 746  
 Zymogen, Formation in Gastric Glands of Adder, 27







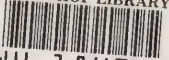

MBL/WHOI LIBRARY  
  
WH 18W9 D

248

