

MOTION OF LIQUIDS

R. DE VILLAMIL

GIFT OF
MICHAEL REESE

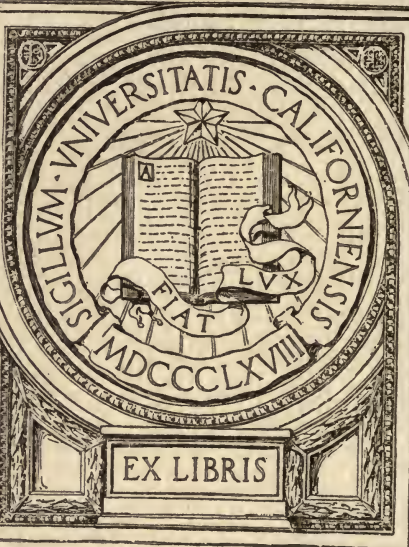

EX LIBRIS

117
11/11



MOTION OF LIQUIDS

BY THE SAME AUTHOR.

A.B.C. of HYDRODYNAMICS.

With 48 illustrations, xi + 135 pp., demy 8vo, cloth (1912).

Price 6/- net.

"A useful and eminently readable introduction to a subject of great importance to the Engineer. It is written in racy style. The gallant Colonel is no respecter of persons . . . but it is well to add that the author seems to us conspicuously fair in his handling of controversial material."—*The Westminster Gazette*.

"The author examines the general conclusions of such writers as Lord Kelvin, Lord Rayleigh, Stokes, Lamb and other theorists in the light of such experiments as those of Osborne Reynolds, Hele-Shaw, Poisenille, Lanchester and others.

"It is particularly suited for engineers and engineering students, who will doubtless find the explanations very helpful."—*The Mathematical Gazette*.

THE LAWS OF AVANZINI

Laws of Planes moving at an angle in
Air and Water.

*With 2 folding plates, 3 illustrations, 23 pp., super royal 8vo,
sewed (1912).*

Price 2/- net.

E. & F. N. SPON, Ltd., 57, Haymarket, London, S.W.

MOTION OF LIQUIDS

By

LIEUT.-COL. R. DE VILLAMIL

R. Eng. (Ret.)

"When a man applies himself and braces his faculties to an investigation of anything, he first asks and ascertains what has been said about the subject by others; then adds his own meditation, and with much mental turmoil appeals to his own spirit and invokes it to open its oracles to him."

BACON, *Novum Organum*.

EIGHTY-SIX ILLUSTRATIONS AND
THIRTY TABLES



London

E. & F. N. SPON, LIMITED, 57 HAYMARKET

New York

SPON & CHAMBERLAIN, 123 LIBERTY STREET

1914

QC151

D4

TO THE
LIBRARY OF THE
UNIVERSITY OF TORONTO

UP.

TO THE
Memory
OF
LE CHEVALIER
COLONEL DUBUAT,
CORPS ROYAL DU GÉNIE,
WHOSE
PRINCIPES D'HYDRAULIQUE
IS
UNFORTUNATELY MUCH NEGLECTED ;
ALSO
COLONEL DUCHEMIN,
ARTILLERIE ROYALE,
AUTHOR OF
THE REMARKABLE BOOK
LES LOIS DE LA RÉSISTANCE DES FLUIDES,
WHICH IS
ALMOST UNKNOWN IN ENGLAND,
THIS LITTLE BOOK,
IS
RESPECTFULLY DEDICATED.

360736

LIST OF PLATES

PLATE	I.	FIG. 44	.	.	.	<i>To face page</i>	116
	„	II. „ 46	.	.	.	„ „	118
	„	III. „ 54	.	.	.	„ „	133
	„	IV. „ 68	.	.	.	„ „	171
	„	V. „ 84, 85, 86	.	.	.	„ „	199

CONTENTS

CHAP.	PAGE
DEDICATION	v
PREFACE	ix
I INTRODUCTORY REMARKS — MOMENTUM — ENERGY	I
II THE “ DIVIDE ”	9
III MOTION OF LIQUID ROUND THE PLATE—FLOW OF LIQUID FILAMENTS IN FRONT OF THE PLATE	23
IV SUBJECT CONTINUED, AND EXAMINED BY REFERENCE TO EXPERIMENTS MADE PRE- VIOUSLY TO DUCHEMIN—THE “ STATIC LIQUID ”	35
V RELATIVE MOTION—MOTION OF STREAM FILA- MENTS IN FRONT OF A BODY AT REST, EXPOSED TO A FLOWING STREAM—“ DU- BUAT’S PARADOX ”	51
VI DUBUAT’S PARADOX, <i>continued</i>	63
VII MOTION OF THE LIQUID AT THE SIDE OF THE PLATE : ALSO BEHIND THE PLATE	76
VIII WATER FLOWING IN JETS—IMPACT	86

IX	JETS STRIKING A PLATE AT AN ANGLE—DUCHEMIN'S FORMULA—DORHANDT AND THIESEN'S FORMULA—JÖESSEL'S FORMULA—M. DE LOUVRIÉ'S FORMULA—M. GOUPIL'S FORMULA—KIRCHHOFF - RAYLEIGH FORMULA — COLONEL RENARD'S FORMULA—VON LÖSSL'S FORMULA	100
X	EXPLANATION OF " DUBUAT'S PARADOX "—THE ADDED MASS—OSCILLATORY PRESSURE	110
XI	MOVEMENT OF LIQUIDS THROUGH APERTURES IN THE WALL OF A VESSEL—MOUTHPIECES	123
XII	SUBJECT CONTINUED—EXTERNAL MOUTHPIECES—THE SEVILLE PUMP—THE BELLANGÉ PUMP	139
XIII	RIVERS AND CANALS—A BODY FLOATING IN A STREAM MOVES FASTER THAN THE STREAM—" CORRAISON " OF STREAMS	154
XIV	NEGATIVE RESISTANCE IN LIQUIDS	177
XV	CURVES OF RESISTANCE—EXPERIMENTAL CONFIRMATION OF THEORY	192
	INDEX	207

PREFACE

IN the *A.B.C. of Hydrodynamics*¹ I have dealt chiefly with the fundamentals of the subject : especially examining the assumptions on which the mathematical treatment was based. In the present little work I have developed the subject by practical application to definite cases of resistance ; especially examining and studying the experimental work carried out by Dubuat and Duchemin, to whose memory I have dedicated this little book.

It is unfortunate that Dubuat's *Principes d'Hydraulique* is at present so exceedingly unpopular ; I am afraid that this is largely due to the author having found out experimentally, that the resistance experienced by a body moving in water, was less than that which it exerted when it was at rest in a flowing stream. This has caused his experiments to be considered as "unreliable."

Since the foregoing may tend to prejudice the reader against this distinguished man's work, I will quote what Sir George Stokes said about him. In his exceedingly interesting papers *On the Motion of Pendulums* we read : "I come now to the experiments of Dubuat, which are contained in an excellent work of his entitled *Principes d'Hydraulique* Dubuat justly remarks that *the time of oscillation of a pendulum oscillating in a fluid is greater than it would be in a vacuum, not only on account of the buoyancy of the fluid, which diminishes the moving force, but also on account of the mass of the fluid, which must be regarded as accompanying the pendulum in its motion : and even determined experimentally the mass of fluid which must be regarded as carried by the oscillating body in the case of spheres and of several other solids. Thus Dubuat anticipated by*

¹ Spon, London, 1912.

about forty years the discovery of Bessel ; but it was not until after the appearance of Bessel's memoir that Dubuat's labours relating to the same subject attracted attention." (*Math. and Phys. Papers*—Italics added.)

Also : "Dubuat's labours on this subject had been altogether overlooked by those who were engaged in pendulum experiments ; probably because such persons were not likely to seek in a treatise on Hydraulics for information connected with the subject of their researches. Dubuat had, in fact, rather applied the pendulum to Hydrodynamics than Hydrodynamics to the pendulum." (Italics added.)

Dr. Thomas Young, in his *Summary of the most useful parts of Hydraulics*, says "another and a more practical mode of attaining hydraulic knowledge has been attempted by a distinct class of investigators, at the head of whom stands Chevalier Dubuat."

Also in his article on *Hydraulics* in Napier's supplement to the *Encyclopædia Britannica*, he adds : "It has happened, from a combination of accidental circumstances, that Dubuat has been deprived of a considerable portion of his first merits, in favour of Mr. Eytelwein, without any kind of voluntary plagiarism on the part of that very respectable professor."

Dubuat's experiments are commonly supposed to violate the "principle of relativity." Such is only apparently the case : we must remember, however, that "If the principle of relativity does not hold good in any domain of actual life, we must seek the cause in the material used, and not in the principle of relativity." (Emphasis added.)¹

The great French Hydraulic engineer and experimenter Bazin, whose work *Recherches Hydrauliques* is quite a classic, refers to Dubuat as "*cet habile expérimentateur*" : to his work as "*les expériences nombreuses et soignées de Dubuat*" : and he makes the following query, in reference to some question, "*comment cette action a-t-elle put échapper à l'esprit sagace et observateur de Dubuat ?*" This is high praise from one who was himself an extraordinarily skilful and careful experimenter.

¹ Paul Carus, *The Principle of Relativity*.

It must be frankly admitted that the arrangement of Dubuat's book *laisse à désirer*; and I have endeavoured to classify and arrange his experimental results, so as to bring out the salient points. Whether his work is "reliable," or not, will, I hope, be shortly decided, since Professor Riabouchinsky has authorised me to state that he will take an early opportunity of repeating both Dubuat's and Duchemin's experiments. The Koutchino hall mark will enable us to judge what is gold from what is dross; for no one will question the accuracy of Riabouchinsky! I attach enormous importance to this, as it will open a new and vast field of thought as regards the resistance of bodies immersed in liquids.

Duchemin's book may be said to be quite unknown in England, no copy is to be found in even the British Museum; it is, further, not an easy book to follow, though it well repays careful study.

In America, Professor Langley refers to Duchemin, "whose valuable memoir published by the French War Department, *Memorial de l'Artillerie No. V*, I regret not knowing earlier." Professor Zahm also speaks of it as, "that remarkable book."

Duchemin repeated Dubuat's experiments (50 years later than Dubuat) and obtained almost exactly the same results. It may be also claimed for him that he was the first to point out that when expressing the resistance of a body moving in air, or other elastic fluid, in terms of the velocity, it was necessary to *add a third term*, involving the *third power of the velocity*; or, algebraically

$$R = AV + BV^2 + CV^3$$

Where A, B and C are constants.

One very simple test of the reliance we can place on the work of these authors, is the following. It is pretty certain that neither of them knew anything about the doctrine of the "conservation of energy" since it was only formulated later. If we then examine the experiments from this point of view, and if we find that *the energy is properly accounted for*, it is *prima facie* evidence that the results may be accepted.

In the *one* case where there is an *apparent* excess of energy, they neither of them offer any explanation of why it *should be so*; they satisfy themselves by saying *we found it so*.

In presenting the subject of the motion of liquids to the reader, I have endeavoured to follow Locke's advice, in his *Conduct of the Understanding*: "in learning anything, as little should be proposed to the mind at once as is possible; and that being understood and fully mastered, to proceed to the next adjoining part yet unknown, simple, unperplexed proposition belonging to the matter in hand, and tending to the clearing what is principally designed." I hope that, by this means, the book will be well within the comprehension of any well educated youth of sixteen or seventeen.

I cannot refrain from making another quotation from the same author. "The sure and only way to get true knowledge, is to form in our minds *clear settled notions of things with names attached to those determined ideas*. These we are to consider, *and with their several relations and habitudes*, and *not amuse ourselves with floating names and words of undetermined signification, which we can use in several senses to serve a turn.*" (Italics added.)

Still another quotation, as a caution to the reader: "Reading furnishes the mind only with *materials of knowledge*; it is *thinking makes what we read ours*. We are of the ruminating kind, and it is *not enough to cram ourselves with a great load of collections; unless we chew them over again, they will not give us strength and nourishment.*" (Italics added.)

Starting from the assumption that when a body moves in a liquid, the latter moves *by some means or another*, from the front to the rear of the body—which is a matter of the very commonest observation—I have endeavoured to show (step by step) *how* the liquid moves, by reference to suitable experiments. Further, by confining my attention to flat plates chiefly, I have been able to neglect the resistance caused by viscosity, and so to treat the fluid as if it were inviscid.

In studying the works of distinguished authors I have found what I can only call, "gaps," which required to be

bridged ; and I have endeavoured to supply the deficiency. For example, I know of no author who treats of the difference between a *static* liquid and one which is *non-static* : I even very much doubt whether most authors have ever thought much about this matter at all. The subject being of the highest importance, I have devoted considerable space to the consideration of this question, which, *when properly grasped*, will show that "Dubuat's Paradox" is *not so absurd* as some people seem to think.

Relative motion. It is generally *assumed* as self-evident, that it is *immaterial* whether the body *or* the liquid moves, *provided that the relative motion is the same*. Once the reader will think, whether the liquid is *static* or not, he will at once see *whether the conditions are the same in the two cases*.

An exactly parallel case may be quoted as regards solids, for "It stands to reason that bodies *in translation* (in which the *entire system*, as a whole, moves in the same direction *with the same velocity* and *without any internal change even of its smallest particles*) *behave as if they were at rest, and so the motion of a straight line cannot be observed so long as the observer remains limited to his own system.*"¹

In treating of the passage of a liquid through a hole in a thin partition I have dwelt a good deal on the great importance of the "co-efficient of contraction ;" a subject rather neglected in textbooks, and the importance of which was not recognized, in some cases, by even the great Bernoulli.

In the chapter on rivers and canals, I refer to many curious points, which do not appear to be as well known as they should be ; amongst others the frequently disputed one of a body floating in a stream *moving faster than the stream*.

Finally, I introduce a subject which is, as far as I am aware, new ; and which I call "negative resistance." I show that (much abused) "viscosity" is sometimes an *advantage*, and actually causes a *decrease* in the resistance of a body moving in a liquid : this being caused by the

¹ Paul Carus, *The Principle of Relativity*.

viscosity *recuperating* some of the *kinetic energy*, which would otherwise be *wasted*. I do not remember having seen in any textbook the idea of measuring resistance *by the amount of energy wasted*: it is, however, a very useful way of examining the question.

I have borrowed freely from many distinguished authors, and I trust that in all cases I have suitably acknowledged the source of my information.

Understanding that it was more agreeable to the reader, I have given a translation only of the quotations from foreign authors in the text; whilst I have relegated their actual words to foot-notes.

Finally, I have endeavoured not to be dogmatic. I do not ask the reader—however young—to accept anything that I may have written *without examination*: rather would I say, with Thomas Davis, “accept no opinion, or set of opinions, without examination, no matter whether they be enrobed in pomp, or holiness, or power; admire the pomp, respect the power, venerate the holiness; but for the opinions, *strip them*; if they bear the image of truth, *for its sake, cherish them*; if they be mixed, *discriminate them*; if false, *condemn them*.” I might go further and (with Lessing) say to the readers, “Think wrongly if you will, but *think for yourselves*” since “the scientific spirit is of more value than its products, and irrationally held truths may be more harmful than reasoned errors” (Huxley).

Now only remains the pleasing duty of again offering my most sincere thanks to Mr. Lewis R. Shorter, B.Sc., for his very keen criticism and most meticulous care in examining disputed questions: not that I would wish in any way to saddle him with the responsibility for certain points which may be considered heretical. Where errors there are (and I have done my best to reduce them to a *minimum*) I accept full paternity. My best thanks are also due to Mr. C. Spon for reading the proofs and also for making the index which enhances the value of the book.

R. DE VILLAMIL.

June, 1914.

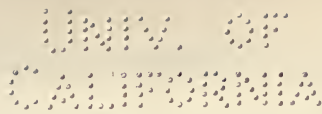

MOTION OF LIQUIDS

CHAPTER I

INTRODUCTORY REMARKS—MOMENTUM—ENERGY

IF a circular disc move in a liquid with its surface normal to the direction of its motion, it is clear that the liquid has to be displaced, so as to allow the disc to pass through it : the liquid *moves*—in *some manner* or another—from the front to the back of the disc. The resistance which a body meets to its motion depends chiefly on the *particular manner* in which the liquid is transferred from the front to the rear of the body.

I have treated of the fundamentals of liquid resistance in the *A B C of Hydrodynamics*, to which the reader is referred : nevertheless, to make this book self-contained, it may be advisable to enter into a few details, even if I have to repeat what I may have said elsewhere.

Newton first pointed out that the resistance to bodies moving in fluids might be divided into three parts. His exact words are : “ The resistance of spheroidal bodies in fluids arises partly from the tenacity, partly from the attrition, and partly from the density of the medium. And that part of the resistance which arises from the density of the fluid is, as I said, in a duplicate ratio of the velocity ; the other part, which arises from the tenacity of the fluid, is uniform, or as the moment of the time ” (*Principia*). Put in other words, the resistance arises from (1) the density, or inertia, of the liquid, (2) from the “ attrition,” or rubbing between the liquid and the solid, and (3) that due to the viscosity (Newton sometimes calls it the want of “ lubricity ”) of the liquid.

This definition is quite complete, and Sir George Stokes has treated the question mathematically and very thoroughly—so thoroughly, that I fancy there is very little left for any other writer to point out.

In dealing with water, we know that there is no motion of the liquid *against the solid*, causing attrition—always presuming that the solid is properly “wetted”: for when the body is wetted a layer of liquid remains permanently attached to it. The result is that Newton’s second term becomes *zero*. The resistance of water is, therefore, composed of two terms only, viz. : (1) that caused by the density—which, it is unanimously agreed, varies as the *square* of the velocity—and (2) that due to the viscosity, or treaciness, and which varies as the *first power* of the velocity only. This last term is in accordance with Newton, who says, “The resistance, arising from the want of lubricity in the parts of the fluid, is, *cæteris paribus*, proportional to the velocity with which the parts of the fluid are separated from each other” (*Principia*). It is clear, therefore, that this can be expressed in algebraical shorthand, as,

$$R = AV + BV^2$$

where A and B are constants.

Since the first term depends on the coefficient of viscosity and the second term on the density, we may put further detail into our formula and express it as,

$$R = A'\mu V + B'\rho V^2,$$

μ and ρ being coefficients of viscosity and of density, A and B being also constants.

We may even enter into more detail and express this in “Dynamical similarity” formula, for bodies of *similar* shape, as

$$R = A''\mu(lv) + B''\rho(lv)^2,$$

where l is the length of (*any*) one dimension.¹ It will be clear from the above that the resistance experienced by a

¹ In case this should be puzzling to the young reader, it may be advisable to point out that this formula only applies to *similarly shaped* bodies. For example, when comparing spheres, cubes, or any other *similar* bodies, the cubic capacity *varies* as l^3 (where l is *any* dimension), the surfaces as l^2 , and the lengths as l .

body moving in an incompressible liquid, such as water, will increase in a *slower ratio* than as the square of the velocities. Equally, the resistance of circular discs, say, will increase at a *less ratio than as the areas*.¹

If the fluid be compressible, then a third term must be added to the formula which will then become

$$R = A\mu(V) + B\rho(V)^2 + C(V)^3.$$

As Newton says: "And when the resistance of bodies in non-elastic fluids is once known, we may then augment this resistance a little in elastic fluids, as our air."

In this case, at moderately high velocities (C being a very small number), the resistance in a compressible fluid, like air, will increase in a *higher ratio* than as the squares of the velocities: also the resistance of circular discs will increase at a *higher rate* than as their areas. This is well known, and the last statement has been shown, experimentally, to be true both by Dines and Eiffel.

The reader may observe that I have made no mention of "liquid friction." This is quite true: but then I do not know what is meant by this expression. Further than that, I have never come across anybody who was able to explain to me what he meant by liquid friction or how it acted. It appears to be *some sort* of resistance which increases as *some sort* of power of the velocity, which may be anything between 1.7 and 2.0; an empirical formula for this is given as

$$R = aV^n.$$

This, so called, "empirical law" does not agree very closely with experiment, and it can hardly be said to explain anything. Besides, an empirical law is rather a contradiction in terms: for law implies necessity, and we cannot feel that a thing *must* be unless we know *why* it must be. Most unfortunately a value of *n* can be found which will give (for

¹ Sir George Stokes (*Mathematical and Physical Papers*, vol. I.), referring to this question says that, according to the common theory, "similar solids of the same material will descend [in a liquid] with equal velocities. These results are utterly opposed to the commonest observation, which shows that large solids descend much more rapidly than small ones of the same shape and material." Here, since the accelerating force is the same, it is clear that the resistance to the larger bodies *must be less*, proportionately.

very small variations of the velocity) an *approximate* value of the resistance. If the *numbers* are not very different, their logarithms are still less different ; so, by plotting the logarithms of the values of the resistances on squared paper, they will be found to lie *almost in a straight line*. A fair line is then ruled through these points, and all differences are assumed to be due to experimental error. This is the system of what is called the "logarithmic homologues."

But to return. If any one tries the experiment of moving a small plate in a body of water—a bath, for example—he will see that the water is not *pushed forwards*, since there is no disturbance of the liquid, at even a *very short* distance in front of the plate : a small body floating in the water will remain at rest until the plate gets very close to it, when it will dart rapidly round to the rear, without apparently touching the plate at all. Any one who has tried taking a floating tea leaf out of a cup of tea will know that it is not always quite easy to keep the leaf in even the hollow of a tea spoon. It is necessary for me to insist on this point, for so much is written, even at the present day, which is so very misleading : such, for example, as the water "striking the plate," or the liquid being "hurled back" by the propeller.¹

¹ Or similarly the air being "shot downwards" by an aeroplane. This last statement is from Sir Hiram Maxim's *Artificial and Natural Flight*. It is fairly intelligible—even if one does not believe it—but there is added, "the air also follows the exact contour of the top-side, and is *also shot downwards* with the *same mean velocity*." [Italics added.] Sir Hiram, however, states that "Even calculations *made on this basis will not bring the lifting effect of the aeroplane up to what it actually does lift in practice* ; in fact the few mathematicians who have made experiments themselves have referred to the *actual lifting effect of aeroplanes* placed at a low angle and travelling at a high velocity as being *unaccountable*." [Italics added.]

No evidence has ever been produced in support of this statement that the air of an aeroplane is "shot downwards" : very careful observers have even stated that they have seen large birds flying quite close to the surface of the Nile without producing the very slightest ripple on the glassy surface of the water. It is certainly true that, when a bird is "suspended" in the air it must compress it : so that, with a sufficiently delicate barometer, one ought to be able to register the increase of pressure caused by a flight of birds overhead.

In the endeavour to be precise, I may ask, what do we mean by the words *push* or *pull*? “A tendency when a body is strained to *resume its original form*; a tendency in a certain relative position of its parts to a certain relative motion of its parts.” (Karl Pearson, *The Grammar of Science*.) Since there is, speaking generally, no tendency in a liquid which has been strained, to *resume its original form*—all liquids taking what engineers call a “permanent set” *at once*—it is clear that it cannot be *pushed* or *pulled*.

I propose to examine the motion of water, *step by step*, both as to *direction* and *velocity* of the stream lines: not taking anything for granted, where it can be tested by experiment, and not proceeding to the next step until the last one has been solidly established, by reference to experiments made in as many different ways as possible. This will be a little tedious, but I must trust to the reader’s patience in following me.

I have said I would take “nothing for granted,” but I must qualify this by saying that I assume the “conservation of momentum” as well as the “conservation of energy.”

To explain myself still further; if a plate is at rest and a jet of liquid moves to meet it, the momentum of a unit volume of the liquid will be mv , where m =mass of unit volume of the liquid and v =velocity. Since v units pass a given point per second, the momentum passing that point *per second* may be expressed by mv .² Now since, by assumption, the plate is fixed, it would appear as if no momentum had been imparted to it, and this would imply *annihilation* of momentum. This is, of course, impossible; the truth being that though the plate is *fixed*, it is, in reality, *fixed to the earth*: the momentum is therefore transferred to the “earth-plate” system, so that the liquid moves the *plate and the earth* at an exceedingly slow velocity; and this velocity is *zero, only if referred to the earth*. The velocity would not be measurable *on this earth*, although it would be measurable if referred to some other point in the solar system.

The direction of the motion may be changed, but the momentum, *in the original direction of motion*, must still

exist. This is equally true if the liquid flows through a bent tube, which may be real or imaginary: in the case of a flowing liquid, the "liquid tubes" are imaginary.

As regards "energy," the total energy per unit volume at a given point in a stream-filament is composed of *potential* energy, or pressure, and *kinetic* energy, which is measured by the velocity: and the *sum of these two is constant at all points of the stream-filament*. Expressed generally, *per unit volume* of the stream-filament,

$$p + \frac{1}{2}\rho v^2 = \text{constant}$$

potential energy + kinetic energy = constant

where p = pressure, v = velocity, and ρ = the density of the liquid; and this $p + \frac{1}{2}\rho v^2$ must retain the same value at all points of the same stream line—*provided, of course, that it always lies in the same horizontal plane.* Or we may say $E_p + E_k = \text{constant}$, where E_p expresses the *potential* energy and E_k the *kinetic* energy: and this total energy is invariable. Potential energy may be converted into *kinetic* energy, or *vice versa*, but the *sum of the two must remain constant*, if we neglect that part which is transformed by the viscosity of the liquid, to *another form of energy, namely, heat.*

In short, whatever the motion of the liquid, there is never any real loss of momentum or energy, though this may apparently be the case if only isolated portions of the liquid are considered.

It would appear here desirable that I should define "energy"; but this, I regret to say, I am unable to do, since I know of no satisfactory definition. Mr. F. Soddy, in *Matter and Energy*, although he says "this is the age of energy," does not attempt to define what it is. It is true that he says, "In physics work and energy are interchangeable terms"; but as, a little later, he speaks of "the amount of work done, and the amount of energy spent in doing it," it is clear that we could not change the position of these terms and speak of the "energy done" and "the amount of work spent in doing it."

"Energy is recognized in two forms, kinetic and potential,

The first depends on motion, the second on the position of the body under consideration, and the law of conservation states that any loss of energy of motion is balanced by a gain due to position, and *vice versa*” (F. Soddy, *Matter and Energy*). Any body which is *capable of performing work* is said to *possess energy*; this, however, does not define what the energy is.

“ Since we cannot give a general definition of ‘energy,’ the principle of the conservation of energy signifies simply that there is *some'hing* which remains constant. Well, whatever may be the new ideas which future experiments may give us of the world, we are sure, in advance, that there will be *something* which will remain constant and which we will be able to call *energy*” (H. Poincaré, *La Science et l'Hypothèse*).¹

I have used the term “ impact,” and it is well that I should here define what I mean by the word. Most writers, I regret to say, employ the term very loosely—in fact, in two senses—and I have found great difficulty in avoiding doing the same. I will therefore divide the expression into two, viz., impact *without shock* and impact *with shock*. If a jet strikes a plate I call this impact (generally): but if the liquid flows away *without reflux*, this is what I call *impact without shock*. If there *is* reflux, then I call this *impact with shock*. If the reader thinks this arbitrary, I must point out that I claim the right to use a word in any sense I please, *provided that I define accurately the sense in which I employ it*.

In order to try and explain, pictorially, what I mean: when a body moves in a liquid at rest, it appears to form a sort of “ liquid prow ” which *divides* the liquid and thus acts as a kind of elastic buffer. in preventing the plate and liquid striking one another *suddenly*. Reversing the action, if the liquid is *moved past* the body, the “ liquid prow ” on

¹ Comme nous ne pouvons pas donner de l'énergie une définition générale, le principe de la conservation d'énergie signifie simplement qu'il y a *quelque chose* qui demeure constant. Eh bien, quelles que soient les notions nouvelles que les expériences futures nous donneront sur le monde, nous sommes sûrs d'avance qu'il y aura quelque chose qui demeurera constant et que nous pourrons appeler *énergie*.

the body *decelerates* the liquid by *slow degrees* so that there is no *shock*—similarly to the manner in which a railway buffer acts in preventing shock between two railway carriages. The momentum is transferred in *very small doses* so as to prevent any *sudden alteration of velocity*.

When a liquid, however, *flows* past a body, it is continually *changing its shape*, and the liquid prow in front of the body is only imperfectly formed : some of the liquid is not properly *deflected* by it, with the result that there is sometimes *impact with shock* between the body and the liquid.

All this will be clear to the reader when he gets to the chapter on jets.

Now since a circular disc in normal presentation *divides* the liquid—and this is equally true for any solid, meeting the liquid at *any angle*—the first point to be quite clear about is *how* the liquid is divided : where does the “ divide ” take place ? It appears clear that there must be *some* point, or line, from which the stream filaments separate ; and that this point, or line, must be on the anterior surface of the circular plate. This will be the special point for examination in the next chapter.

SUMMARY

A body moving in a liquid *divides* it : the body cannot and does not, *push* the liquid forwards.

REFERENCES

- NEWTON'S *Principia*, vol. ii. (Motte's Translation).
 Sir HIRAM MAXIM, *Artificial and Natural Flight*.
 KARL PEARSON, *The Grammar of Science*.
 F. SODDY, *Matter and Energy*.
 H. POINCARÉ, *La Science et l'Hypothèse*.
 Sir GEORGE STOKES, *Mathematical and Physical Papers*.

CHAPTER II

THE " DIVIDE "

IN the early part of the nineteenth century Colonel Duchemin carried out some experiments with the object of finding out how the stream-filaments meeting a plane surface divided ; the results of which he published in his *Recherches expérimentales sur les lois de la résistance des fluides*. His experiments were made in water, and his method was as follows. A plate of sheet iron, which had at first the form of a circle of 0.422 m. (17 inches, nearly) diameter ; then that of a square of 0.3 m. side ; and subsequently that of a rectangle of 0.3 m. by 0.2 m., was pierced with sixteen holes of 0.003 m. diameter. These plates could be fixed, in the usual manner, in running water at any required depth of immersion. By a very simple arrangement of cog-wheels, a small vane (0.015 m. \times 0.04 m.), the axle of which worked freely through any given hole, was able to indicate on a dial, above the level of the water, the direction in which the vane was turned by the moving water. It will easily be understood that all the holes in the plate, but one, having been stopped, the axle of the vane passing through the open one, he could note the *direction of the flow* of the liquid *at this point*. By repeating the experiment with all the other holes, a " chart " of the flow of the liquid, all over the plate, could be made. In the case of the circle it was found, as would naturally be expected, that the flow on the front face was strictly radial, as in fig. 1. In other words, the " divide " was a point, in the centre of the circle.

When the axle of the vane was reversed through the holes,

it was found that the flow at the *rear* of the plate was also radial, from the centre to the circumference; so that fig. 1

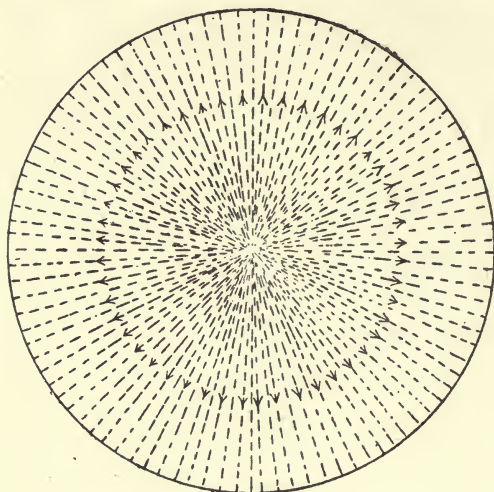

FIG. 1.

will indicate the lines of flow both at the front and at the back of the circular plate in "normal presentation." This, also, is what a reader of the *ABC of Hydrodynamics* would naturally expect. In both cases the "divide" is at the centre of the circle.

It is necessary to be very careful not to confuse the term "divide"—

which is, of course, the point, or line, of *greatest pressure*—with the *centre of pressure*. In this case they are the same, but in a great many cases they are not. It is well to avoid anything like confusion.

Exactly similar experiments having been carried out with the square plate, the lines of flow are indicated in fig. 2.

In this case, also, fig. 2 represents the lines of flow across both the front and the back of the plate. There appears

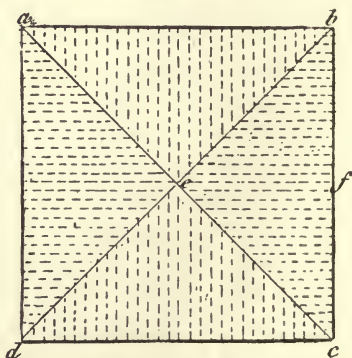

FIG. 2.

to be a division of the stream, or "secondary divide" along the diagonals of the square. Duchemin says, in reference to this, that "it does not appear that there are [on the posterior side] currents following these lines." [The diagonals.] It seems more probable, however—if not certain—

that there must be *some* flow from *e* to *a*, *b*, *c*, and *d*, but that the vane, when pointing in these directions, was in unstable equilibrium and so never took a fixed position along either of the diagonals.

When the experimental plate is a rectangle the streams, *whether on the anterior or posterior side*, still divide themselves into four sheets of water, directed towards the perimeter; but the lines of division of the sheets appear to be curved, and they seem to divide the angles into two equal parts, as in fig. 3. Duchemin says, "on the anterior face there are streams which follow the curved diagonals: analogous ones *have not been recognized on the posterior face.*" [Italics added.] The reason for this would appear to be similar to that given previously for the square plate.

In the case of a rectangular plate the primary divide is a line, and this is accompanied by secondary divides in the direction of the corners of the rectangle.

To explain the "divide" by a parallel example; if we imagine rain to fall on a conical hill the "divide" will be

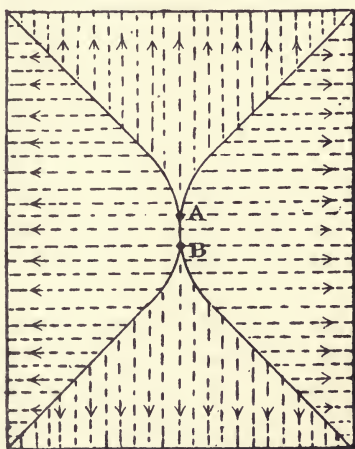

FIG. 3.

the point of the hill. Similarly, if the hill be shaped like a square pyramid, the "primary divide" will also be at the point; but along, what I may call, the spurs of the hill there will be "secondary divides," which are lines along the spurs. Again, if the hill be shaped like the hip roof of a house, the "primary divide" will be a line along the ridge of the roof, whilst there will be "secondary divides" which are lines along the hips.

All these experiments were repeated when the plate was moving in still water and with exactly similar results. From this we may conclude that the flow of the water *across the faces of these plates* was the same *whether the plate was at*

rest and the water was moving, or, conversely, if the plate moved in the water at rest. I wish to draw special attention to this, because most writers, assuming that action and reaction are equal and opposite, and that everything depends on the "relative motion" only—which is perfectly true *if the conditions are exactly similar*—consider all this as quite "self-evident." We should remember what d'Alembert said:—"Mathematics, which should only be the servant of physics when they are working together, frequently commands them. The more useful the application of mathematics to physics, the more one should be circumspect in this application. We must therefore know how to draw the line where our ignorance commences and not think that the words theorem and corollary become, by some secret virtue, the essence of a demonstration; and that in writing at the end of a proposition *which was to be demonstrated* one will have *proved that which is not true.*"¹ It is necessary to be cautious: theory may be in error, so we must take nothing for granted, if the truth or error can be experimentally verified. I will return to this subject later.

As it was interesting to know what the flow was like, when the plates, always in normal presentation, were only *partly immersed* in the water, Duchemin made the necessary experiments. The level of the flowing stream at the spot where the plate was fixed, was determined by the use of a very thin plate placed edge-wise to the stream, and which did not produce any sensible stoppage of the liquid. The exact depth of immersion of the plate could thus be determined with accuracy.

Let A B C D (fig. 4) represent the submerged portion of the plate, A B being the undisturbed water level: the lines of flow divide into four sheets (below the surface) *exactly*

¹ La géométrie qui ne doit qu'obéir à la physique quand elle se réunit avec elle, lui commande souvent. Plus on peut tirer d'utilité de l'application de la géométrie à la physique, plus on doit être circonspect dans cette application. Il faut donc savoir s'arrêter sur ce qu'on ignore, ne pas croire que les mots et de théorème et de corollaire, fassent par quelque vertu secrète l'essence d'une démonstration et qu'en écrivant à la fin d'une proposition *ce qu'il fallait démontrer*, on rendra démontré ce qui ne l'est pas.

as they did when the plate was wholly submerged, allowing for the difference in shape of the submerged part; that is to say K is half way between h and l . The stream filaments of the sheet of liquid $A K B$ do not, however, stop at $A B$ but rise to the level efg ; the flow being as represented by the dotted lines. They then appear to curve slightly backwards—away from the plane of the paper—flowing right

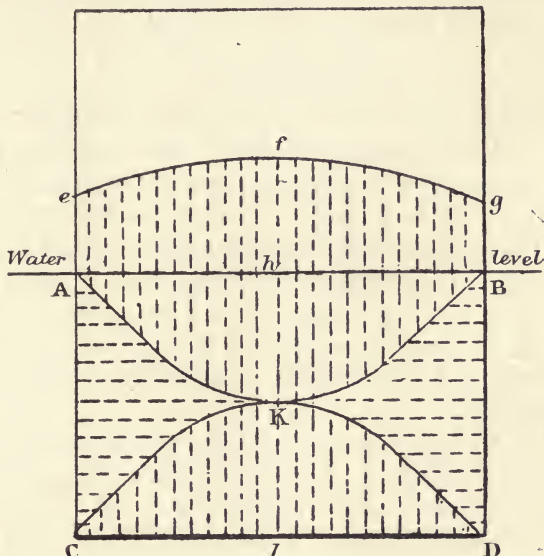

FIG. 4.

and left, and so moving past the plate.

When the posterior face of the plate is examined, it is found that the flow here differs, very materially, from that at the front. The point K^1 (fig. 5) is sensibly higher

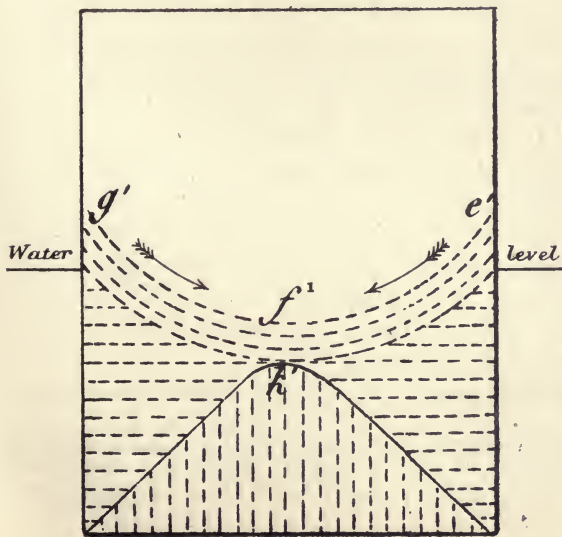

FIG. 5.

than K , whilst f^1 is much lower than f —being, in fact, below the level of the surface of the stream. The stream-filaments divide into *three sheets* only, instead of four, whilst there are streams flowing from e' and g' to f' . The movement of the water is evidently quite different at the rear of the plate from what it is at the front. The water is dammed up in front, whilst there is a depression behind.

These experiments were also repeated when the plate was moving in still water and with the same results—within the ordinary limits of unavoidable experimental error. Duchemin, when commenting on these experiments, says: ‘This phenomenon has been known for a long time, but what was *not* known is that the liquid divides into sheets on the anterior side of $A B C D$ in the same manner as if this part were isolated in the middle of the water.’ [Italics added.]

Duchemin was evidently not aware that, about forty years before, Avanzini claimed to have observed the same thing. He said, referring to his experiments (*Istituto Nazionale Italiano*, Tomo ii., Parte 1). “In all these experiments, since the axis of equilibrium will be found *above the centre of figure of the immersed part of the lamina*, and since the centre of resistance must fall in this same axis, it is easy to see that whatever is the portion of the lamina which is immersed, whatever its breadth, velocity and inclination, the *centre of resistance always falls in the centre of figure of the aforesaid immersed portion of the lamina.*”¹ His exact words are: “In tutti questi sperimenti trovandosi l’asse d’equilibrio sopra il centro di grandezza della parte immersa della lamina, e nell’asse medesimo dovendo cadere il centro di resistenza, è agevole il conoscere che qualunque sia la porzione immersa della lamina, qualunque la sua larghezza, velocità, è inclinazione, sempre il centro di resistenza cade nell’centro di grandezza della suddetta porzione immersa della lamina.”

I am afraid the worthy abbot is a little mixed in this

¹ By “axis of equilibrium,” is meant the axis about which the plate was free to turn, whilst it was in equilibrium. “Centre of resistance” is clearly the reverse of the “centre of pressure.”

statement : chiefly, I fancy, from employing one word to express the "centre of pressure" and the "divide," or *point of greatest pressure*. It is clear that if the "centre of resistance" (or centre of pressure) was always found *above*

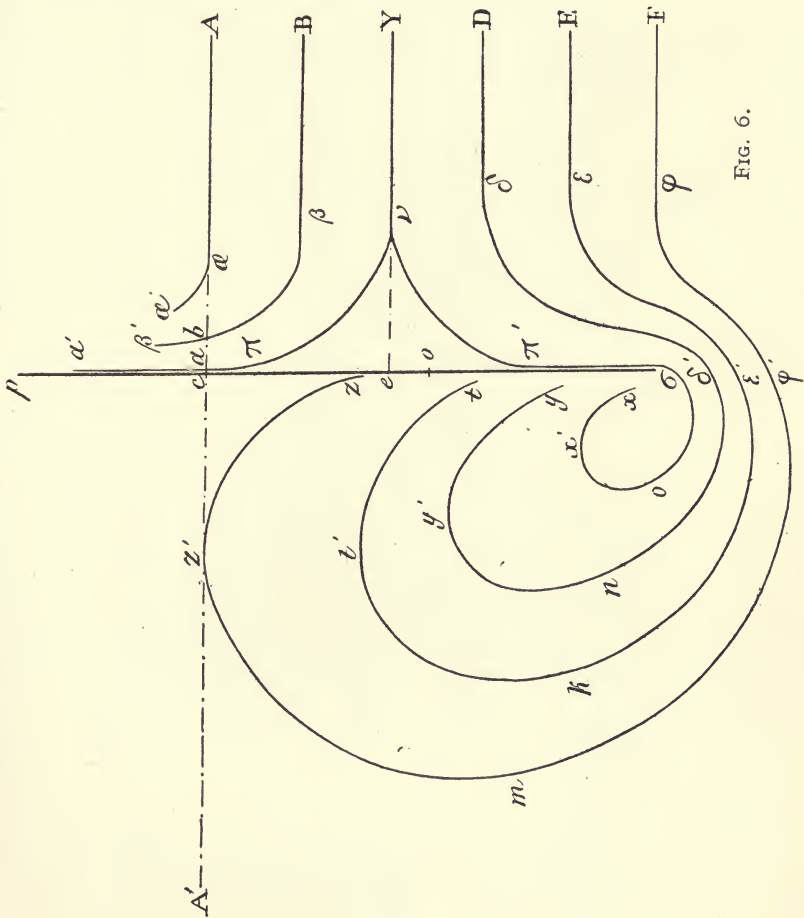

FIG. 6.

the centre of figure of the immersed part of the plate, how could this centre of resistance always fall in the centre of figure of the immersed portion of the same plate? It seems probable that what he meant was that the "divide" was in the centre

of figure of the immersed part. In fact, I think the next paragraph leaves no doubt that he recognized that the

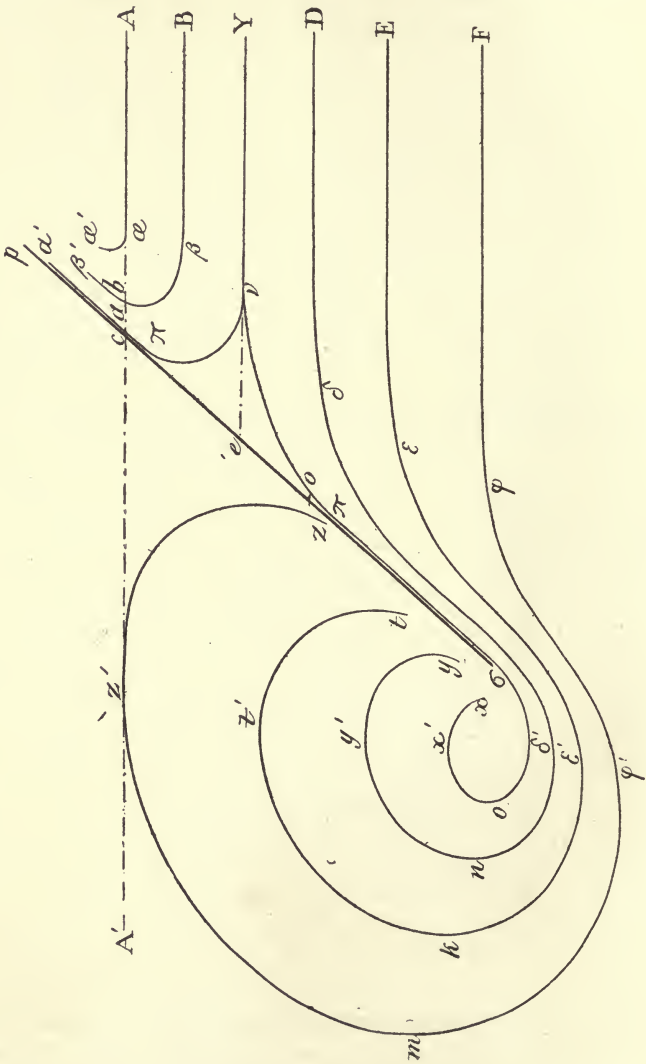

FIG. 7.
Projection of line of divide = evY .

centre of pressure of the immersed part of the plate was at the centre of this immersed part. On the other hand, his diagram does not show the "divide" at this point. Fig. 6 is a photographic reproduction of Avanzini's drawing, where the divide is shown as above the centre of figure. Avanzini's statement is also too broad and sweeping, for he says that this is true for all angles of inclination: it appears pretty certain that this is only true for "normal presentation."

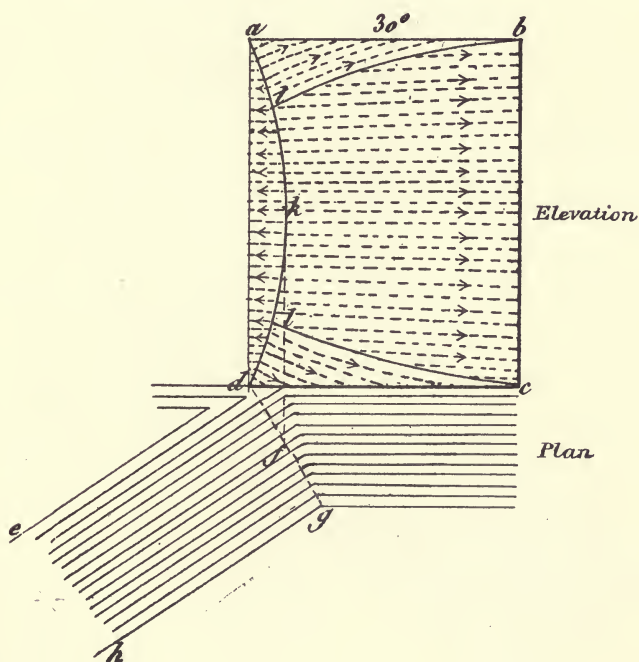

FIG. 8.

Avanzini's own drawing of the plate moving at an angle—of which fig. 7 is an exact copy—certainly does not support his own claim: since the divide is *very considerably* above the centre of figure of the immersed part of the plate. In any case it is curious to find that so much was known about this subject so long ago.

Avanzini's curves of the vortices were worked out on theoretical lines, and were then checked by observing the

lines of flow, by the use of small balls of the same specific gravity as the water and suspended in it.

Knowing now where the "divide" is on plates in normal presentation, both wholly and partly submerged, the next case that calls, naturally, for inquiry is how this divide would be affected if the plate were at an angle to the stream.

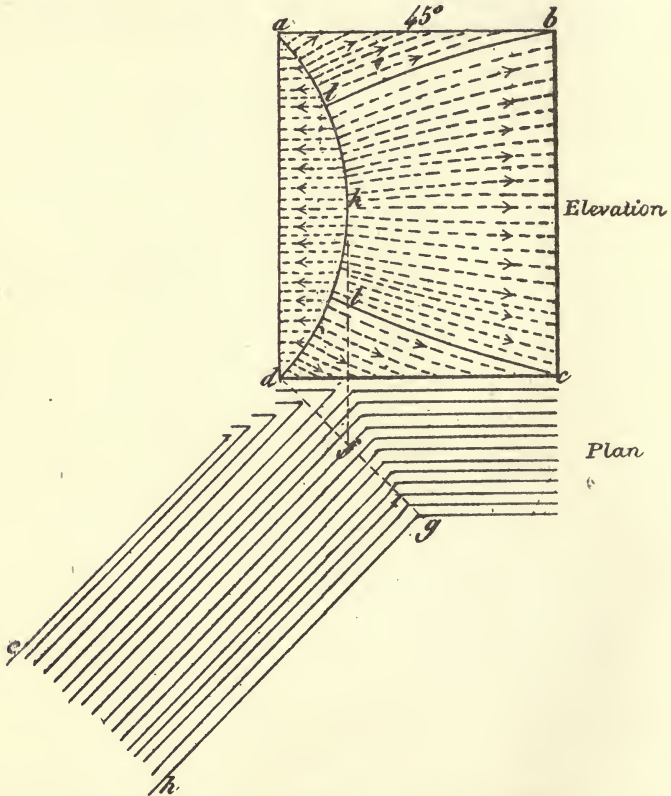

FIG. 9.

To determine this Duchemin's rectangular plate was exposed (vertically) at angles of incidence of 30° , 45° and 60° to the action of running water. The first trials showed that the number of holes in the plate was not sufficient, and twelve more were bored symmetrically.

The results are curious and were certainly unsuspected

by Duchemin: they are represented in figs. 8, 9 and 10, which are copied from his own diagrams. $d c$ represents the plan of the plate which is vertically exposed, $e d g h$ representing, diagrammatically, a horizontal projection of the column of water which is moving to meet the plate $d c$ obliquely. It is obvious that the stream lines do not

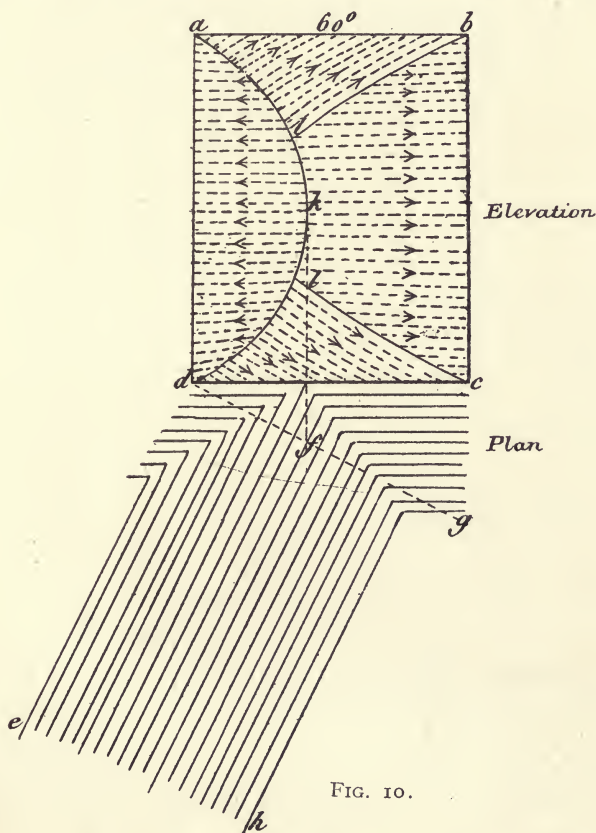

FIG. 10.

bend at these very sharp angles: it will, however, simplify the explanation to imagine (*for the present*) that they do so: the error can be very easily corrected later— $a b c d$ represents a vertical elevation of the anterior face of the rectangular plane, with the "divide" and the directions of the motion of the stream-filaments marked on it.

One of the first things one notices is that, as the angle of incidence, or "attack," decreases, the "primary dividing line" $l k l$, between the sheet of liquid moving towards $a d$ and the other sheet moving towards $b c$, approaches $a d$: this line being, of course, the line of greatest pressure; and which, in normal presentation, passes through the centre of the plate.

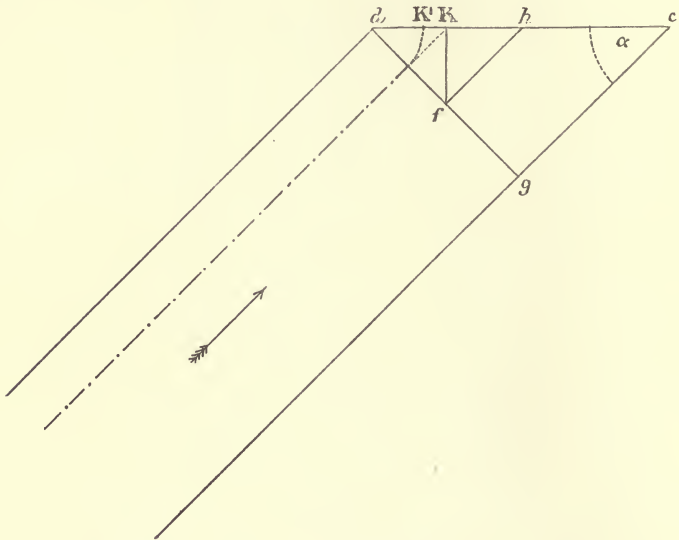

Fig. 11.

A very rough method for finding the position of K , and its distance from the leading edge (or from the centre) of the plate is to draw $d g$ at right angles to the direction of the flow of the stream (fig. 11); bisect it in f and then draw $f K$ perpendicular to $d c$. Drawing $f h$, parallel to $g c$, it is clear that, a being the angle of incidence, or "attack,"

$$(fh) = \frac{1}{2}(gc) = \frac{1}{2}(dc) \cos a.$$

$$\text{also } (Kh) = (fh) \cos a = \frac{1}{2}(dc) \cos^2 a$$

and if we represent dc by l , then

$$(Kh) = \frac{1}{2}l \cos^2 a \text{ and } (dK) = \frac{1}{2}l \sin^2 a.$$

This method has no pretensions to accuracy. If one wishes to find the correct position of the divide it is probable

that one must employ the formula given by Lord Rayleigh

$$d = \frac{2(1 - 2\cos a + \cos^3 a) + a \sin a}{4 + \pi \sin a}$$

where d is "the distance from the anterior edge of the point where the stream divides, and where accordingly the pressure attains its greatest value" ¹ (*Scientific Papers*, Vol. I).

The values of d at different angles are given in this paper as:—

90°	$d = .5000 \times$ length of plate.		
70°	$d = .2676$	„	„
50°	$d = .0981$	„	„
30°	$d = .0173$	„	„
20°	$d = .0040$	„	„
10°	$d = .0004$	„	„

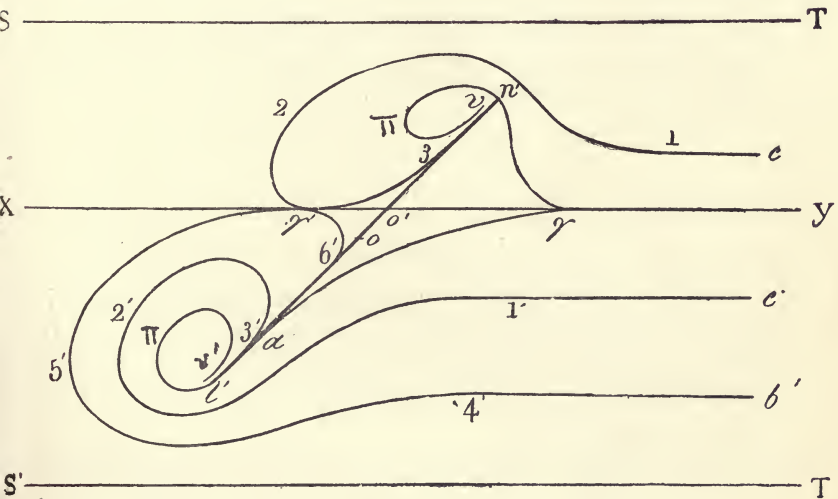

FIG. 12.

In fig. 11, the dotted line does not, with an actual liquid, strike the plate *at an angle*, at K, as shown. It really bends round so as to meet the plate *normally*, at some point K¹—

¹ It is necessary to be careful to note the *assumptions* on which this formula is based.

as represented, diagrammatically, in fig. 11; the distance between K and K¹ *increasing* as the *angle of attack decreases*.

The stream-filaments of the sheet of fluid *alkld* (fig. 10) appear to be refluxed obliquely along the surface of the plate.

The movement of the liquid at the posterior surface of the plate is much more complicated; and Duchemin was unable to give any graphic description of it. Nevertheless he was led to believe that the line of the "divide" of the fluid filaments on the posterior side of the plate corresponded to that on the anterior side: the general effect, he says, showed him in a very positive manner that the motion of the fluid on both these faces was *from the interior to the perimeter*—agreeing in this with Avanzini's drawing given in fig. 12.

Knowing, now, how the liquid divides on both sides of a plate, both at normal and oblique angles of attack, in the next chapter I propose to examine the motion of the liquid round the plate, more in detail.

SUMMARY

When the presentation of differently shaped plates is normal, the "divide" appears to be similarly situated, both on the front and rear surfaces: this is true, whether the *body is at rest* and the *liquid moves*, or when the *body moves in liquid at rest*.

When the "presentation" is acute, the exact position of the divide on the posterior face appears to be a little doubtful.

REFERENCES

Colonel DUCHEMIN, *Recherches Expérimentales sur les lois de la résistance des fluides*.

D'ALEMBERT, *Traité de l'Équilibre et du mouvement des Fluides*.

AVANZINI, *Istituto Nazionale Italiano*, Tomo II, Parte I.

LORD RAYLEIGH, *Scientific Papers*, vol. I.

CHAPTER III

MOTION OF LIQUID ROUND THE PLATE—FLOW OF THE LIQUID FILAMENTS IN FRONT OF A PLATE

IN order to enable him to examine the direction of motion of the stream-filaments round the plate, Duchemin fixed sixteen pieces of strong fine wire to a square wooden plate, so as to completely surround it. Each wire had three small strips of brightly coloured silk fastened to it, at different distances, like small flags. By noting the direction that these pieces of silk took up, he was able to make a very fair chart of the different eddies, etc.

When the plate was moving in normal presentation, in still water—being fixed to a boat—he found that the shape of the eddies behind the plate might be expressed diagrammatically, as in Fig. 13: what I may call the “depth” of the eddies being somewhere about half the breadth of the plate. This corresponds very closely with the drawing given by Avanzini, and which he made after observing the flow of small light balls of nearly the same weight as the water. Fig. 14 is a photographic reproduction of Avanzini’s drawing; and a comparison between this and Fig 13, which is an exact reproduction of Duchemin’s drawing, will show the very close general agreement between the two observations.

Duchemin also remarks that the *shape* of the eddies *did not appear to change with any alteration of the velocity of the plate.*

When the plate was at rest, however, and exposed to a stream of *flowing* water, the eddies were somewhat different ;

being of the same breadth, but the length (or "depth") of these moving eddies he found extended to, roughly, about

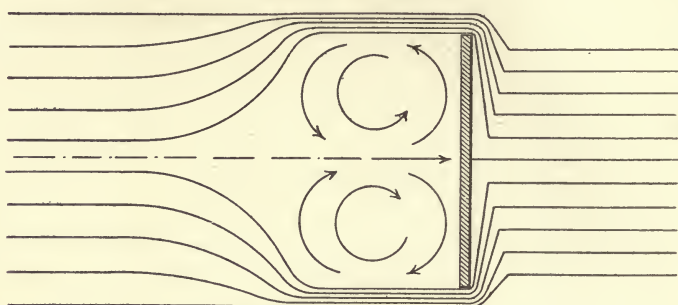
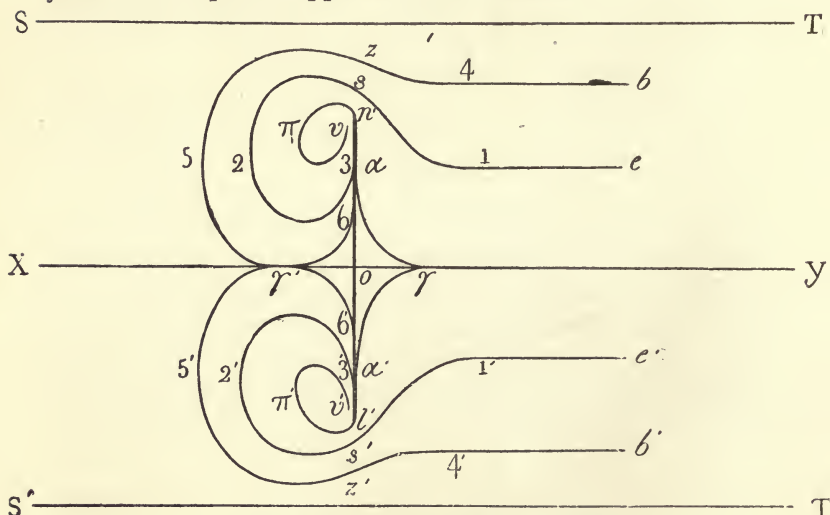

Plate moving: water at rest.

FIG. 13.

four times the breadth of the plate. The results did *not* appear to be the same in the two cases; though the flow in the front of the plates *appeared to be identical*.



Avanzini plate in normal presentation.

FIG. 14.

The next point Duchemin examined was the effect on the flow caused by putting prismatic bodies behind the

plate. Rectangular prisms of proportions $1 : 1 : 1$, $2 : 1 : 1$, and $3 : 1 : 1$ —single, double and treble cubes—were fixed behind the *moving plate*, and the results were found to be exactly similar to those produced behind the plate alone—except that the eddies in rear of the solid bodies appeared perceptibly *weaker* than those produced behind the plate alone.

When the *bodies were at rest* in the *moving stream* the results were certainly curious. The eddies behind the cube occupied a space whose *depth* was now only about *one and a half* times the breadth of the plate—instead of nearly four times, as with the plate alone. Behind the body of proportions $2 : 1 : 1$ —the double cube—the depth of the eddies was further reduced to about *three quarters* of the breadth of the plate; whilst behind the treble cube ($3 : 1 : 1$) the depth of the eddies was only about *half the breadth of the plate*—or about the same size as the eddies behind the plate when it was moving in still water or behind the treble cube

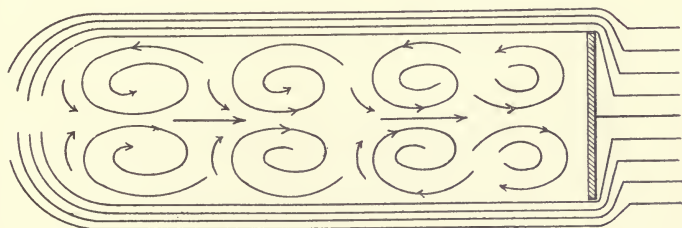

Plate at rest: water flowing past it.

FIG. 15.

moving in still water. The reasons for this very curious effect will be referred to again at greater length after a more detailed examination of the motion of the water in front and around the plate.

From these experiments, the general impression that one would carry away is, that when a *plate is at rest* in flowing water, more eddies are formed—i.e., *more Kinetic energy is generated*—than is the case when the *plate itself moves* in still water. In the case of the cube this difference is still apparent but *much less accentuated*; with a double cube

the difference appears to be small; whilst with a treble cube there appears to be *no difference at all*. This curious effect requires to be pondered over.

Another fact that Duchemin noted was that "The molecules of water, deviated by the shock ¹ of the anterior face, are not only those comprised in the prism moved through by this face, but *also those in the neighbourhood*, and the deviation appears to *extend in front* to a distance of *about half the breadth of the surface*."

"In the course of these experiments, which were repeated several times, one had occasion to remark that the *directions of the filaments* which were in the neighbourhood of the surface remain the same when the *velocity increases or diminishes* by *insensible gradations*. So that the filaments deviated round the surface *form a system with it*, and are carried with it (*entraînés*) in its movement." All this is in accord with Dubuat's observation that "when a body resists the action of a current, the fluid is deviated at a certain distance in front of it, and there is formed a *sort of liquid prow*, in which the filaments, *without losing all their velocity*, have less than the rest of the fluid *in the direction of the general motion*."

Having now a rough general idea of the *direction* of flow of the different stream filaments, it is important to explore the *velocities* of these stream-filaments, all round the plate, or other body. The instrument used by Duchemin was Dubuat's modification of the original Pitot tube. The upright part of the tube was made of tinned iron and had a length of 0.954 m. with an interior diameter of 0.032 m. The lower part was curved and terminated (at right angles to the upright part) in a cone with a small circular hole of 0.0035 m. in diameter: this small hole being in a plane strictly normal to the direction of the branch of the tube, so that it might be strictly normal, also, to the stream-filament whose velocity it was desired to measure. In the interior of the upright tube was placed a small hollow cylinder, or float, of copper, of 0.065 m. in length and of 0.026 m. in diameter. This float would clearly be able to

¹ Duchemin believed in actual liquid shock to some extent: he is a little obscure on this point.

move up and down the tube freely. On the top of the float was fixed a small collar of 0.015 m. in length and 0.0035 m. diameter, intended to receive a small rye straw. The arrangement was probably as shown in fig. 16.

In the original Pitot tube, one of the great objections was the excessive oscillation of the level of the liquid in the upright tube: it was also difficult to read this level with accuracy. In Dubuat's modification, the diameter of the

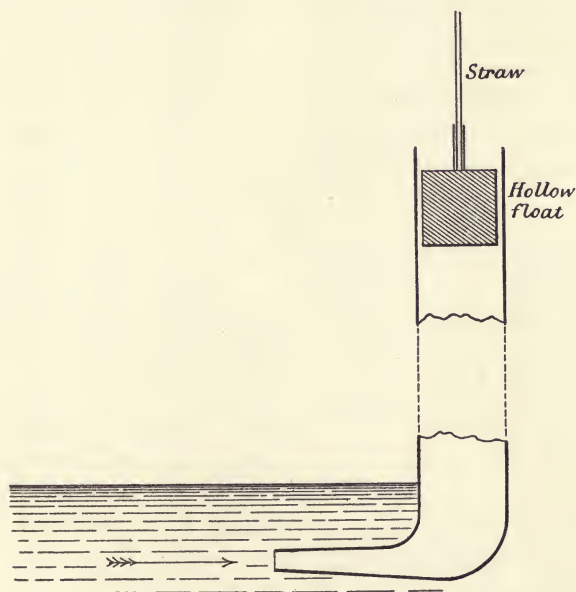

FIG. 16.

upright tube being ten times the diameter of the lower aperture, it is clear that the area of one being one hundred times that of the other, the oscillations will be heavily "damped." The use of the rye straw also allows of the reading being made much more conveniently, and above the level of the surface of the water.

Without entering into further details, the reader will easily understand that the height of the level of the liquid in the tube could be measured with a considerable measure of accuracy by means of a scale, fixed close to the straw.

When the instrument was employed with a fixed plate in running water, the thin plate (previously referred to) placed edgewise in the stream allowed the level of the surface of the stream to be measured accurately.

As to the properties of this instrument, it is well known that if the orifice of the tube be placed below the surface of running water, and *perpendicularly to the direction of the motion* of any stream-filament, the elevation of the float above its primitive position is equal to the height (or "head") due to the velocity of the current, when the *liquid is moving*; or the velocity of the tube, when this is moving and the *liquid is at rest*. This height, which will be designated by h , is commonly spoken of as the "velocity head." It is more convenient to measure this than the velocity, which

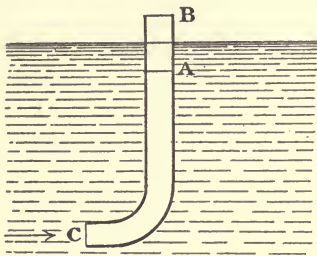

FIG. 17.

can always be calculated by the formula $v = \sqrt{2gh}$, where v = velocity and g = coefficient for gravity, h is, clearly, the *head* which would be required to give a velocity v .

It is also well known that if the direction of the orifice be *reversed* the surface of the liquid in the upright tube will *descend below the level of the surface of the stream* by a quantity which is *also equal to h* , or the height due to the velocity, whether the water or the tube be in motion: it depends solely on the *relative velocity* between the two.

It will be seen, therefore, that by fixing the tube in any position near the plate at any given depth, if we know the *direction of flow* of the stream-filaments at this spot, we can measure the velocity of flow of the liquid in these filaments with great accuracy.

Another observation, first made, I believe, by Dubuat, is that it is *indifferent whether the orifice of a tube be drowned or not, to give a constant discharge, provided that the tube runs full, and that the head is the same in both cases*. That is to say, if the liquid flows in at C (fig. 17) with a velocity head

h , the discharge would be the same (neglecting friction) whether it takes place at B—above the surface of the liquid—or at the drowned point A. This is, clearly, only strictly true if the mouth of the tube is only *just above* or *just below* the surface of the liquid, so that the *head it is discharging against* is the same in both cases.

Referring again to fig. 4, the point K which separates the stream-filament Kl , directed downwards, from the stream-filament Kh , directed upwards, is at the centre of the immersed part of the plate $ABCD$; that is to say at the middle of lh , and this could only be if the reactions of the molecules which move in these two streams, or small tubes, were equal

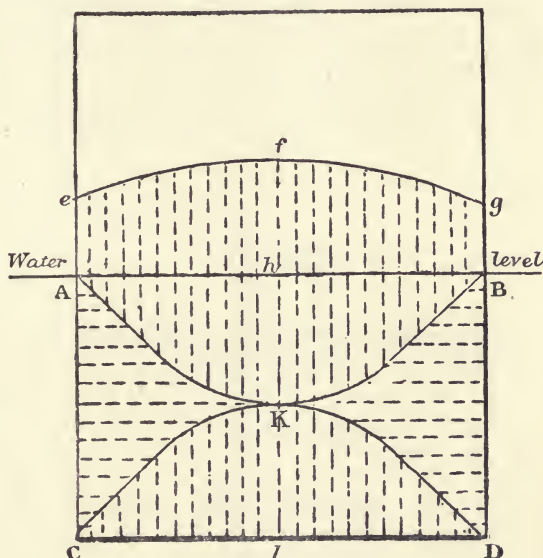

FIG. 17A. (FIG. 4.)

and opposite ; or if the “ heads ” were the same at the two orifices h and l of the imaginary liquid tubes.

To explain my meaning more clearly, let hKl (fig. 18) represent a vertical section of the partly immersed plate in fig. 4, hKl being the immersed part. The two imaginary liquid tubes are shown, diagrammatically, as bending towards h and l . The velocity of the flow in the tubes at h and l will be the same, and the reactions caused will be equal and opposite. The “ velocity heads ” at h and l will be equal. But as the height hf to which the water rises above the orifice h , of the imaginary tube, is clearly the height due to the velocity of the molecules of water when they are

leaving this orifice, it will also, therefore, be the height due to the velocity of the molecules of water which are leaving the orifice l . It follows from this that by determining experimentally the height hf for different lengths of Kh —by augmenting or diminishing the submerged part $ABCD$ of the plane surface—one can obtain the “velocity head” of the water at different distances along the fluid stream from the point of inflexion K .

After a large number of experiments Duchemin found that this velocity can be satisfactorily found by means of the following empirical formula:—

$$v = u \left(1 + \frac{e}{K} \right)^{\frac{1}{2}}, \text{ or } H = h \left(1 + \frac{e}{K} \right) \dots \quad (a)$$

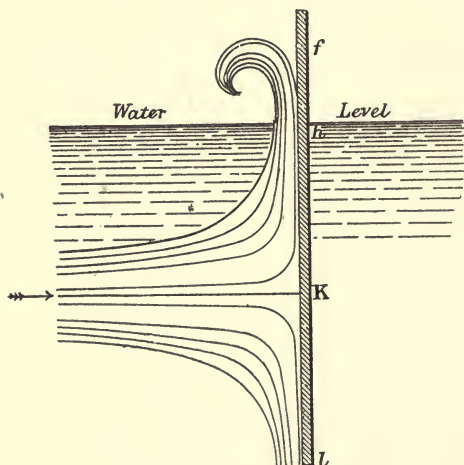

FIG. 18.

where u = velocity of the undisturbed stream in front of K (fig. 17a).

h = velocity head of this stream-filament.

v = velocity of the liquid molecules at the end of the distance e , which the molecules have travelled across the surface of the plate.

H = velocity head corresponding to velocity v .

e = length Kh , equal to $\frac{1}{2} AC$ (fig. 4), half the depth of the immersed part of the plate.

$K = 0.25379$ m., a constant linear quantity of the same kind as e .

This formula, which is a purely empirical one, is only true within certain limits: it is clearly *not true* when $e = 0$.

In the experiments which Duchemin made on the water

in movement meeting the plate at rest, the value of h , or the "velocity head" of the current at the centre K was taken with a Pitot tube before the plate was fixed in position, the point of the tube not passing through the plate, but through the point which was later the centre of the plate. A scale marked on the plate enabled the height hf , or H , to be read off directly. The results are given in Table I, annexed.

The first column of this table gives the breadth of the plate exposed to the stream; the second, the half depth of the immersed part of the plate—or the e in the equation—the immersion being measured below the ordinary level of the surface of the stream; the third, the velocity head of the stream at the centre of the immersed part of the plate; the

TABLE I.
BODY AT REST.

Breadth of Surface.	Values of		Head H	
	e	x	Observed .	Calculated.
	m.	m.	m.	m.
0.300m	0.050	0.055	0.065	0.0658
	0.100	0.055	0.079	0.077
	0.150	0.055	0.087	0.0875
	0.200	0.055	0.097	0.098
	0.250	0.054	0.107	0.107
0.150m	0.300	0.054	0.118	0.118
	0.150	0.055	0.089	0.088
	0.300	0.055	0.118	0.120
0.200m	0.150	0.055	0.087	0.88
	0.300	0.054	0.121	0.118

fourth, the height of the centre of the "lip,"¹ or eddy, hf observed; whilst the fifth column gives the value of this "lip" calculated by Duchemin's formula (a).

It will be observed, on comparing the two last columns,

¹ I know of no English word for this, so I have adopted "lip," which is the translation of the Italian word "labbra" used by Avanzini.

that the formula (a) gives results which are in very close agreement with those observed.

Exactly similar experiments were made with the body moving in still water, and the results are given in Table II.¹

This table, which is exactly similar to the last, shows also the very close agreement between the observed values of H and those calculated by the formula (a), notwithstanding the fact that the *velocities of motion* have varied very sensibly.

One may therefore conclude from these experiments that the height of the "lip," or eddy, H, against a plane in normal presentation partly immersed in a liquid, may be expressed by formula (a), whether the surface is at rest and the water moves, or whether the plate is moving in water at rest.

TABLE II
BODY IN MOTION

Breadth of Surface.	Values of		Head H	
	<i>e</i>	<i>h</i>	Observed.	Calculated.
	m.	m.	m.	m.
0.300	0.100	0.062	0.087	0.085
	0.200	0.056	0.098	0.100
	0.300	0.051	0.110	0.111
	0.400	0.044	0.115	0.113
0.150	0.200	0.068	0.120	0.122
	0.400	0.052	0.134	0.134
0.200	0.200	0.059	0.109	0.106
	0.300	0.054	0.119	0.118

If this explanation of the manner of flow of the water from the centre of figure of the immersed part of the plate be the correct one, it should be true for *all* cases. Duchemin

¹ For the future, for the sake of brevity (and simplicity), I shall only refer to the *body*, as being in motion or at rest. "Body at rest" must be taken to imply that the liquid is *flowing* past it; "Body in motion" that it is moving at *uniform velocity* in the *liquid at rest*—or what we, ordinarily, call "at rest."

made a slightly different experiment to test this, acting as a kind of crucial test.

A square plate $abcd$, length of side $=0.250$ m., was cut out of a board, leaving a prolongation of one of the diagonals, age as in fig. 19. This was immersed in a stream having a velocity of 1.048 m.; the velocity head, or h , of which being 0.056 m. The diagonal ac was vertical, and the angular point a was at the primitive surface of the flowing stream.

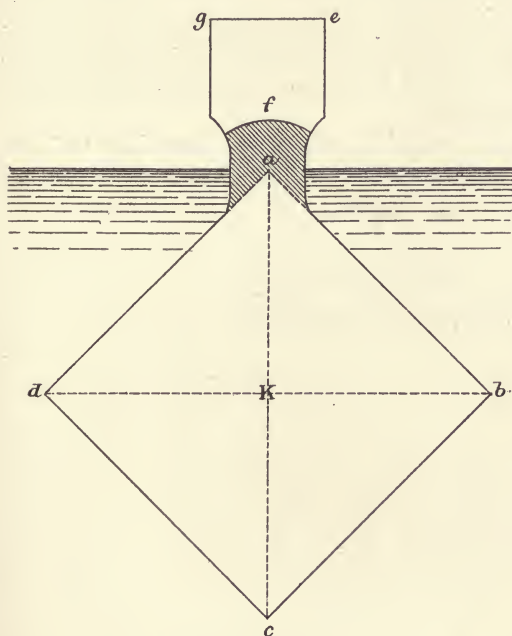

FIG. 19.

The fluid rose along the line Ka to the height $af = 0.093$ m. Now this elevation of the water is, evidently, due to the velocity acquired by the molecules of water, which we have recognized as following the direction of the diagonal ca of the square. Therefore if we insert in the formula (a) the value of $h = 0.056$ m. and that of $e = Ka =$

0.177 m., we shall obtain $H = 0.095$ m., a value which only differs from the observed height by 2 millimetres, or about 2 per cent. From this it appears that af —or H in Tables I and II—is the head corresponding to the velocity v , which the fluid filament has acquired in travelling across the surface of the plate from K to a , this velocity being *in excess* of the velocity of the *undisturbed stream at the point K* .

In the next chapter we will examine this question further

by using the experiments of other and earlier observers than Duchemin.

SUMMARY

The flow behind a plate does not *appear to be* the same when the plate is moving in liquid at rest, as it is when the plate is at rest and the liquid flows. *More kinetic energy appears to be generated* in the latter case than in the former. The same result appears behind a cube, and a double cube, though the effect is not so marked. Behind a treble cube no difference is apparent.

What Dubuat called the "liquid prow" appears to have a length equal to half the diameter of the anterior face of the body exposed to the liquid.

REFERENCES

Colonel DUBUAT, *Principes d'Hydraulique*.

CHAPTER IV

SUBJECT CONTINUED, AND EXAMINED BY REFERENCE TO
EXPERIMENTS MADE PREVIOUSLY TO THOSE OF DUCHEMIN

IN the last chapter we examined the direction of motion and the velocity of flow of the different liquid-filaments flowing across the front of a plate, which was either (1) moving in a liquid at rest, or (2) was itself at rest, with the liquid flowing past it. We saw that Duchemin's formula (*a*) enabled us to calculate the velocity of these filaments at the edge of the plate with a considerable degree of accuracy. It will have been noted that all the experiments referred to had been executed by Duchemin himself; and when one sees that all the experiments accord very closely with any theory, one is inclined, not perhaps unnaturally, to be a trifle suspicious. In the very excellent programme of instructions formulated by the Académie des Sciences, and according to which Duchemin was working, it was laid down that any empirical formulæ which he might be able to establish should be "subsequently compared with the mass of experiments *made previously* on this subject." This I propose now to do.

I know of no modern experimenters who have measured this "lip," or eddy, formed in front of partially immersed moving plates; so that we must be satisfied with some rather old measurements. The Abbé Bossut's experiments, carried out for the French Government more than one hundred years ago, are classical; Colonel Dubuat, who was a very careful observer, also experimented for, and at the expense of, the French Government; the Abate Giuseppe

Avanzini is the third and only other experimenter on this subject that I am acquainted with.

Commencing with Bossut, the accompanying Table III gives the results of experiments executed with *moving bodies*. In this list of the results of thirty-one measurements, column No. 1 gives the number of the experiment in Bossut's report (*Nouvelles Expériences sur la résistance des fluides*) No. 2 the details of the bows of the boats the measurements were made on, No. 3 the time in half-seconds taken in travelling 50 feet,¹ No. 4 the value of e —half the depth of immersion, whilst 5 and 6 are the values of H , as observed and as calculated by the formula (a):—

$$\text{where} \quad H = h \left(1 + \frac{e}{K} \right)$$

when h = "velocity head" on the motion, e = half the depth of immersion, and $K = 0.25379$, a constant linear quantity of the same kind as e .

The bodies experimented with were boats which had prows of different shapes; in experiments 855, 864 and 865 the prows were flat and perpendicular to the direction of the motion; the prows of the 858 and 862 boats were angular and formed angles of incidence of $63^\circ 26'$ in the former and $21^\circ 48'$ in the latter cases; those of the last two boats were semi-cylindrical surfaces, the axes of the cylinders being vertical. If we put t to represent the number of seconds employed in travelling the 50 feet, then the velocity $u = \frac{50}{t}$,

from which it results that $h = \frac{u^2}{2g} = \frac{(50)^2}{2gt^2}$. This expression

gives, by employing the values of $2t$ given in the third column of the table, the values of h , or the "velocity head" of the body; and putting these values of h and those of e , given in the fourth column, in the formula (a) we obtain the values of H in the last column. We see that the calculated and observed values of H are as close as it would be reasonable to expect, taking into account the very great difficulty in carrying out these kinds of experiments.

¹ The feet are old French feet, divided into 12 inches, and each inch into 12 lines. The "pied royal" = 1.06578 ft. (E)

TABLE III
BODIES IN MOTION

No. of Supt.	Breadth of Surface.	$\frac{1}{2}$ seconds per 50 ft.	Values of e.	Head H.		
				Observed.	Calculated.	
	In. lines.		In. lines.	lines.	lines.	
855	12"	{ 43·70 38·37 34·75 52·00	} 6" 00	21'''	20·47'''	
				26"	26·55'''	
				34'''	32·37'''	
				15'''	14·66'''	
864	19" 8'''	{ 46·05 42·07 37·25 35·18	} 6" 2 $\frac{3}{4}$ '''	18	18·71'''	
				20·5	22·42	
				26·0	28·59	
				32·5	32·06	
865	19" 8'''	{ 50·75 46·50 41·00 36·50	} 7" 11'''	15·0	17·06	
				18·0	20·33	
				24·0	26·15	
				33·0	34·55	
858	Angular prow Length 6" Breadth 24"	{ 33·69 50·00 43·50 38·50	} 6"·00	37·00	38·73	
				34·92	16·0	15·64
				36·62	21·0	20·66
				33·40	27·0	26·38
862	Prow angular Length 30" Breadth 24"	{ 30·81 28·62 27·00 36·00	} 6"·00	30·0	28·56	
				34·0	32·07	
				29·0	29·16	
				33·0	35·05	
872	Prow cylindrical Semi- circular	{ 30·81 28·62 27·00 36·00	} 3" 11'''	38·0	41·19	
				45·0	47·73	
				52·0	53·63	
				26·0	26·08	
873	do. do.	{ 32·20 29·60 27·40 44·00	} 6" 2 $\frac{3}{4}$ '''	33·0	32·60	
				40·0	38·58	
				46·0	45·02	
				20·0	20·50	
		{ 38·50 35·40 32·69		26·0	26·77	
				32·0	31·66	
				38·0	37·13	

These experiments, besides giving results conformable with Duchemin's formula (*a*) show another thing, and that is that the same results are obtained whether the body is a thin plate or a solid ; and whether the surface in presentation is a dihedral angle or the circular surface of a cylinder.

Dubuat executed many experiments, but I only know of

one where he measured the "lip," or eddy, of water rising against a plate. In his *Principes d'hydraulique*, No. 442, he states that he placed a thin box in a running stream so that its lower surface was 8 inches and 4 lines below the primitive surface of the stream, and that a "lip" was formed with a central height of 3 inches 7 lines. The velocity of the stream at a depth of 4 inches and 2 lines was 42·1 inches per second, corresponding to a velocity head of 2 inches 5½ lines; the breadth of the box was 12 inches. We have, therefore, for this experiment $e=4$ inches 2 lines, and $h=2$ inches 5½ lines; putting these values in the formula (a), we find $H=3$ inches 6⅔ lines, a quantity which only differs from the observed amount by $\frac{2}{5}$ of a line, or about 1 per cent.

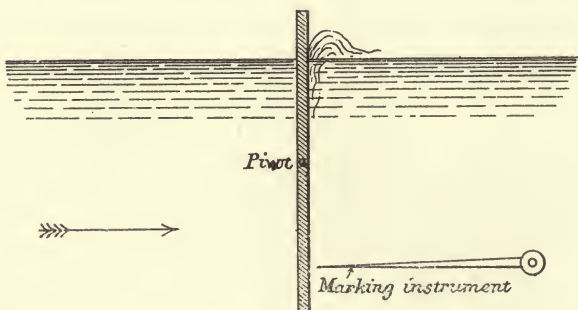

FIG. 20.

Avanzini's experiments, though apparently very carefully executed, give results which are *not in accord* with the foregoing. I can only account for this by the fact that his plates, *moving in still water*, were *balanced on pivots*, and so were free to oscillate; and although he says no oscillation was *perceptible*, I am inclined to think some must have taken place. It is, further, by no means certain that his plates moved *strictly in normal presentation*; the eye is a poor judge of this, and his method of measuring the angle—fairly accurate for small angles of attack—is very defective when the angle approaches a right angle: the plates when arriving at the end of their run being struck by a sharp point, fixed horizontally, and so *marked*, the measurement of the angle being made subsequently at leisure. The

arrangement is shown diagrammatically in fig. 20. It will be clear that any small error in the horizontality of the marking instrument might cause a large error. Even, however, if the marking point were correctly adjusted, an error of several degrees in the angle of the plate might easily be made.¹

I propose to apply a kind of "cross-check" to this question later, but meanwhile it is useless to blink the fact that Avanzini's experiments are in disaccord with those of others. It appears to be a pity that he did not carry out his experiments *with the plates clamped* in position.

Since it is well, at times, to take stock of one's ideas, in order to "scotch up" some line of thought, I will now enumerate the results we may be said to have arrived at from the study of these experiments.

1. Whether the plane surface, in normal presentation, and partly submerged, is moving in a direction normal to this surface in water at rest, or whether the plate is at rest and the liquid is flowing past it, the height to which the water will rise, above its primitive level, against the centre of the vertical anterior face, can be expressed by the formula (*a*); and it is the same in both cases, *all conditions being*, of course, *the same*.

2. This height is independent of the breadth of the plane surface; it remains constant even when the plane part of the surface is reduced to a vertical line, as at the centre of a cylindrical surface, or at the edge of a dihedral angle.

3. It is the same, *under similar conditions*, against a simple plane lamina, or against a solid body which has a similar plane surface for its anterior side.

4. This height depends entirely on the motion of the molecules of the stream-filament moving from the centre

¹ In *The Laws of Avanzini* I have given drawings of the apparatus used; these are photographically reproduced from the originals. For the reader who does not know the arrangement I may mention that the plate was free to oscillate about pivots, which were fixed to a carriage moving *above the surface of the water*. When the carriage had completed its run, the plate was struck by a fine point, as in fig. 20, and so *marked*. The carriage being then brought back, so that the point and *mark* corresponded, the angle of attack was measured by means of a plumb-bob and a protractor.

K (fig. 4) of the submerged surface, to the point h on the line of immersion, the velocity of these molecules at the point h being expressed by $v = u\sqrt{1 + \frac{e}{K}}$, where u = velocity of undisturbed stream at the point K . e = half depth of immersion; $K = 0.25379$, a constant linear quantity of the same kind as e .

When an artist, in painting a picture, wishes to draw

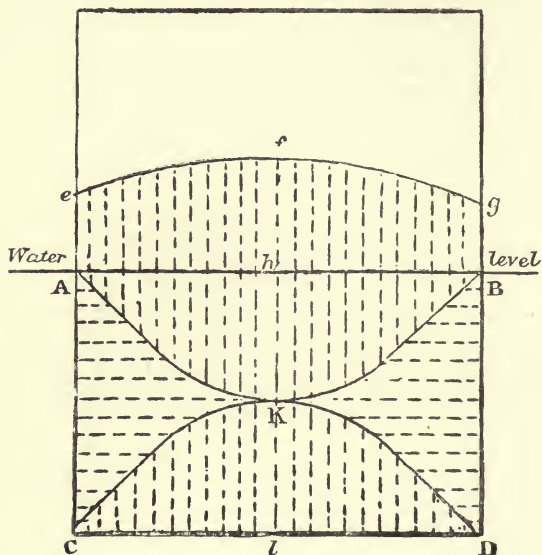

FIG. 20A. (FIG. 4.)

attention to some particular point, he produces his effect by a sharp contrast of either line, colour or shadow. Similarly, as I wish to draw special attention to this point, I will make as sharp a contrast as I can between the view here

advanced and that commonly taught in the schools. I will select as my guide a very excellent modern text book, by an author who is a member of several learned societies, and so, not likely to teach anything that is not quite "correct." Referring to this subject, the argument is somewhat as follows:—

Let the body have the form of a rectangular box of length l and breadth b ; and let it be immersed to a depth d in the liquid. When the body is moving forward with a velocity V , the liquid immediately in front of it must also be moving with a velocity V ; for this to be possible, the liquid must

be heaped up in front of the body (fig. 21). To determine the height h to which the liquid must be heaped up, let it be supposed that a velocity, equal and opposite to that with which the body is actually moving, is impressed on the body and the whole of the liquid. Then if A is a point on the surface of the liquid to which the disturbance created by the body has not extended, the velocity of the particle of the liquid at A is equal to V ; and if the particle has unit mass, its kinetic energy is equal to $\frac{V^2}{2}$. When the particle reaches the point B at the summit of the ridge immediately in front of the body, its velocity in the plane of the diagram (fig. 21) has decreased to zero, and the particle has risen to

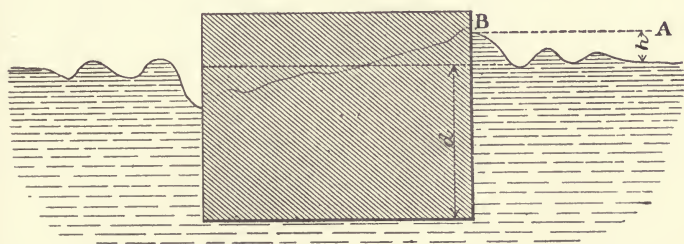

FIG. 21.

a height h above the undisturbed surface of the liquid; thus the increase in its potential energy is equal to gh , and this increase has been gained at the expense of the kinetic energy which has disappeared. The foregoing will give a very fair general idea of the line of argument and of the assumptions on which it is based.

Now, apart from the (I think) rather clumsy way of expressing that the body is at rest, by imparting to it a velocity $+V$ and then superposing another velocity, $-V$, this train of reasoning is based on several very unjustifiable assumptions. It is assumed that the particle at A in travelling towards B begins by forming a small wave, which gradually increases in amplitude until the particle arrives at B. Nothing is said about how this molecule of water gets away from B, for it is clear that it cannot stick there. We are

not told if the liquid is a "static" one or if it *flows* like an ordinary liquid. The student is told (somewhat unnecessarily it would appear) that the depth of immersion is d ; whilst the explanation takes no account of this, thus leaving him to suppose that the height of the "lip" is the *same for all depths of immersion*. The author also produces no "machinery" for the formation of the waves shown in the diagram. Had he inserted the "stream lines," I fancy we should have seen the fluid-filaments diverging from the centre of the *immersed part of the surface*, and flowing along the face—up, down, right and left. As was pointed out by Dubuat more than a century ago, "The lip which is formed before the vertical face of a floating body is not composed of stagnant water, but of molecules which tend to escape at the surface of the current, as they do in all the other directions. The invincible obstacle that they meet obliges them to turn in gliding along the surface, to escape by the edges."¹

The waves shown in the diagram (fig. 21) are partly caused by the secondary action of the liquid "cascading" backwards, after arriving at B, the motion being, more or less, as shown in Avanzini's diagram (fig. 6). This is not, however, the whole truth, for, as Riabouchinsky² has remarked, "the water rises and falls *periodically*": this, if I understand his explanation correctly, implies that these undulatory movements necessitate an *undulatory pressure* at the centre of the plate. As will be seen later, and approaching the subject from an entirely different point of view, I have arrived at the conclusion that such an undulatory pressure *must* exist, and I trust I have given a satisfactory explanation of *how it is caused*.

The ordinary explanation has not even the merit of being very simple and easily understood. Of course the h in the

¹ Le remou qui se forme devant la face verticale d'un corps flottant n'est pas composé d'une eau stagnante, mais de molécules qui tendent à s'échapper à la superficie du courant, comme elles font dans tous les autres sens. L'obstacle invincible qu'elles rencontrent les oblige de se détourner en glissant le long de la surface, pour s'échapper par les bords."

² *Bulletin de l'Institut de Koutchino*. Fascicule IV., 1912.

diagram *might* be equal to $\frac{V^2}{2g}$ (if the surface velocity happened to bear the correct relation to the velocity of the stream at the depth $\frac{d}{2}$); but again, it equally might *not*.

If the liquid were a "static" one, this could not be the case, since the velocity at all parts would be the same.

The height h bears no immediate relation to $\frac{V^2}{2g}$: in fact, as long ago as 1763 (*Mémoires de l'académie*) de Borda found that the "lip" against a moving cube *did not much exceed* that due to the "velocity head" of the surface layer of the liquid.

I propose now to examine this question from a slightly different point of view; acting as, what I may call, a "cross check" on the views previously advanced. Before doing this, however, it is advisable that I should give a description of some of the "tools" I am going to employ.

I have had occasion to use the expression "static liquid," or "static fluid." As this is not very commonly found in books—I do not remember ever having seen it in any text-book—it will, not improbably, be unfamiliar to the ordinary reader; quotations might even be given from several writers who appear to be quite ignorant of the difference between *static* and *non-static* liquids.

A static liquid is generally defined as one which is *neither changing velocity, nor changing shape*. This definition, whilst being strictly accurate and complete, will, however, I am afraid, convey but a very blurred image to the mind of the ordinary reader. To give a clear and distinct "picture" it will be necessary to give a few examples of both static and non-static liquids, and to point out some of the properties of static liquids which are *implied* in the foregoing definition.

It might be imagined that the simplest form of static liquid is one which is *at rest*. The expression "liquid at rest," however, without any further qualification, is meaningless. We do not know whether any liquid is *actually at rest*—in fact, we have every reason for knowing that such

a thing *does not exist*—and we most certainly have no means of measuring whether it is so or not. Rest and motion are only relative terms in physics.

The water in a pond, near London, which is at rest, *referred to the earth*, would be water moving at a velocity of about 800 miles per hour, *if referred to a point just outside the earth*. Besides this, the earth is moving some *tens of thousands of miles per hour* round the sun; and we do not know the exact velocity of the sun.¹ It is clear, therefore, that we require some “frame,” and that we cannot speak of any *absolute* velocity, but only of a “relative velocity” —referred to some points in our frame. When, therefore, we speak of liquid “at rest,” it must be understood as at rest *relatively to the earth*; so also, if we speak of uniform velocity of a liquid—or of a liquid not *changing its velocity*² —it is always to be understood as *referred to the earth*. Anything else would be meaningless, as it is impossible to get any other kind of uniform velocity, since in addition to its rotational movement about its axis, the earth’s translational motion is constantly *changing its direction and magnitude*.

If the question of *not changing its velocity* is important in the definition of a static liquid, it is vastly more important that it should not be *changing its shape*.

To give an example of a static liquid: imagine a tank on wheels on a railway, and filled with water. If this tank be standing still on the rails, it is a static liquid—it is neither changing its velocity nor shape. If the same tank be moving at a uniform velocity of fifty miles per hour it is *still* a static liquid, for the same reasons.

If, however, water be *flowing* in a canal it is *not* a static liquid, for though its velocity may be uniform—be *not* changing—it is perpetually *changing its shape*, in consequence of the velocity at the surface exceeding that at the bottom and sides.

¹ Professor Dr. J. C. Kapteyn, in May, 1908, said at the Royal Institution: “We have been able of late to fix with some precision the velocity of this motion, which amounts to 20 kilometres per second.

² We might, perhaps, better say its “rate of velocity.”

In case the reader should not thoroughly grasp my meaning, when I say a liquid is "changing shape," I will give a very simple example. Suppose the liquid is an ordinary viscous one, flowing at a low velocity, the motion is represented, in all textbooks, as in fig. 22. A represents, diagrammatically, a body of liquid divided into horizontal laminæ at a certain instant of time t_0 ; B represents the same body at a later instant of time t_1 . It is obvious that this body has *changed its shape*. In the last analysis it can be easily shown that *all* the molecules have *rotated through some angle θ* .

I trust that the reader will now have a clear idea of what I mean when I speak of a "static liquid."



FIG. 22.

A property, which is *implied* in the definition of a static liquid, is that the pressure is *the same in all directions* at any given point: this is a fundamental question on which a great part of the science of Hydrodynamics is based, as well as the whole of Hydrostatics.¹

We see, therefore, that if a liquid is *moved past* a solid, at uniform velocity, the liquid is a "static" one. In short, a

¹ The equations of Hydrostatics are founded on the principles that the mutual action of two adjacent elements of a fluid is normal to the surface which separates them, and that the pressure is equal in all directions. . . . The same assumption is made in Hydrodynamics, and *from it are deduced the fundamental equations of fluid motion*. But the verification of our fundamental law in the case of a fluid at rest, *does not at all prove it to be true in the case of a fluid in motion, except in the very limited case of a fluid moving as if it were a solid*" (Sir George Stokes, *Mathematical and Physical Papers*, vol. I. Italics added). The fluid moving as if it were a solid is, very clearly, a *static* fluid.

static liquid is one which is *moving like a solid*, its velocity being either positive, or negative, or zero. It is clear, also, that a gravitational *flowing* liquid is *not* a static liquid. When the body moves past a liquid *at rest* (as defined previously) *at a uniform velocity*, the liquid is, in all cases, a static one, but not if the body is being accelerated.

In referring to Pitot tubes it is very common for writers to speak of the *static* and *dynamic* pressures as being recorded by them. This is very confusing, for it is clear that if a liquid is not a static one you cannot measure its "static pressure": it is further misleading as it suggests that the pressure in the liquid is *different in different directions*. This leads to a flat contradiction; for, *by definition*, in a static liquid the pressure *must be equal in all directions*.

In order to try and clarify the subject I may point out that if the *plane of the orifice* of the tube is opposite, and *normal to the flow of any stream filament*, the *flow* of the liquid at the orifice is reduced to zero: so that the height to which it rises is a measure of the "velocity head." This is commonly called the "dynamic pressure"; but a little reflection will show that it is a *measure of the kinetic energy* of the stream line *at this particular spot*. I therefore prefer to call it the kinetic pressure or kinetic head: and when H is used by me it will always be intended to mean the *measure of the kinetic energy* at the place where the orifice of the tube is, i.e., the *kinetic head*.

Now, since $E_p + E_k = \text{constant}$, it is not difficult to *calculate* the potential energy or pressure of the stream filament at this point. The Pitot tube will, however, do this for us, without any trouble; for if we turn the plane of the orifice through two right angles, so as to be *directly away from the line of flow*, the liquid will *descend* as much *below its primitive level* as it rises above it in the former case, when the orifice is *facing the stream*. It is clear that this reading H' may be used as a *measure of the potential energy*: so, as before, we may call H' the "potential head," or pressure, of the stream filament at this particular spot. It must be noted that I always consider the values of H and H' as *measured in the same direction*: H' is not the measurement *below* the

primitive level of the stream, i.e., measured *negatively*, but a *positive measure* above some arbitrary datum line.

Similarly, I shall always express the "velocity head" of the *undisturbed stream* at this point by h .

Having clearly defined the exact meaning of these terms, if we imagine fig. 23 to represent the values of H , h and H' at some point near the plate where the stream has been disturbed, so that the stream-filaments are flowing faster at this point than the velocity of the undisturbed stream; they are all measured from an arbitrary line h units below the upper extremity of h .

It is clear that since H is as much *greater* than h , as H' is less:—

$$H - h = h - H' \text{ therefore}$$

$$H + H' = 2h; \text{ also } \frac{H + H'}{h} = 2$$

Now if we *calculate* H by formula (a) and *measure* H' we should find that $\frac{H + H'}{h} = 2$.

In order to verify this, Duchemin made a thin square sheet-iron box of 0.300 m. side and 0.030 m. thickness. The front face $abcd$ had five holes of 3 millimetres diameter pierced in it: No. 1 at the centre; Nos. 2 and 3 in the same vertical line at distances 0.075 m. and 0.150 m.; Nos. 4 and 5 on the diagonal at distances respectively 0.106 m. and 0.212 m. There was a vertical tube to this box and a float in it, as shown in fig. 24, so as to measure the level of the water in the tube. This box was fixed on the front of a boat, the velocity (or h) of which was measured by another independent Pitot tube, which was *quite clear of the box*. It will be evident that by closing *all the holes but one*, the pressure at the open hole can be measured by the rise or

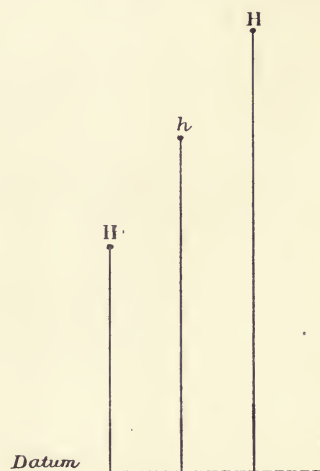

FIG. 23.

fall of the float. The results are shown in the annexed Table IV, where the first column gives the number of the

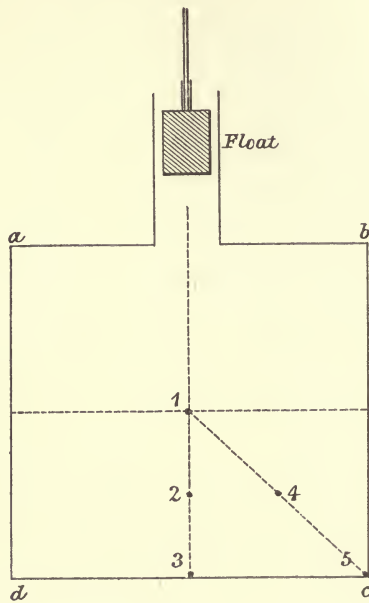

FIG. 24.

TABLE IV
BODY IN MOTION.

No. of Hole.	Value of h Velocity Head.	Value of H' Potential Head.	Value of $\frac{H'}{h}$	Values of		
				e	$\frac{H}{h}$	$\left(\frac{H+H'}{h}\right)$
	m.	m.		m.		
1	0.056	0.058	1.036	0.000	1.000	2.036
2	0.051	0.035	0.686	0.075	1.296	1.982
3	0.053	0.022	0.415	0.150	1.591	2.006
4	0.057	0.034	0.596	0.106	1.418	2.014
5	0.049	0.007	0.143	0.212	1.835	1.978

The values of $\frac{H}{h}$ have been calculated by the formula (a).

hole ; the second column the value of h , or the *velocity head of the boat* ; column 3, H' , the reading of the tube in the box (what I have called the "potential head") ; column 4, the relation $\frac{H'}{h}$; column 5, the value of e ; column 6, the value of $\frac{H}{h}$ (H calculated by formula (a)) ; and column 7, the value of $\frac{H+H'}{h}$. It will be seen that the experiment thoroughly confirms what was said previously, from a theoretical point of view, when the *body is in motion* and the *liquid at rest*.

Dubuat in the *Principes d'Hydraulique*, No. 474, gives the results of exactly similar experiments, detailed in Table V, which requires no special explanation. The box was 1

TABLE V
BODY IN MOTION

No. of Hole.	Value of h Velocity Head.	Value of H' Potential Head.	Relation $\frac{H'}{h}$	Values of		
				e	$\frac{H}{h}$	$\frac{H+H'}{h}$
1	lignes	lig.	1.063	0	1.000	2.063
	19.52	21				
	19.81	22				
	21.91	24				
	23.22	25				
	39.34	42				
	39.99	42				
	43.11	45				
	48.29	50				
	50.00	52				
2	26.67	8.5	0.318	6	1.640	1.958
	51.97	16.5				
	58.09	18.5				

foot square (old French feet = 12 pouces = 144 lignes). Hole No. 1 was at the centre of the box ; hole 2 was at the edge of the box (Fig. 24 will practically serve for both sets of

experiments). It will be seen that these experiments also quite confirm what had been argued theoretically, when the *body was moving* and the *liquid was at rest*.

They are further useful in deciding another point. The *assumption* was made that *there was no impact with shock*: since the conclusions agree with experiment it appears reasonable to think that the assumption was correct—*there was no impact with shock*.

The experiments made when the *body was at rest* and the water was flowing past it lead to some surprises; and so will be reserved for a separate chapter.

SUMMARY

Experiments made before the time of Duchemin, by careful observers, confirm the accuracy of formula (a) $H = h\left(1 + \frac{e}{K}\right)$: the sole exception being the experiments of Avanzini, which appear questionable, in consequence of the plate having been free to oscillate.

Separate experiments of Duchemin and Dubuat where *kinetic* energy was calculated and *potential* energy was measured (*the body moving in a liquid at rest*) also confirm the value of the formula.

REFERENCES

- l'Abbé BOSSUT (and M. M. D'ALEMBERT et le Marquis DE CONDORCET), *Nouvelles expériences sur la résistance des Fluides. Bulletin de l'Institut de Koutchino*, Fascicule iv., 1912.
 Le Chevalier DE BORDA, *Mémoires de l'Académie*. 1763.
 Professor Dr. J. C. KAPTEYN, *Recent Researches in the Structure of the Universe*.

CHAPTER V

RELATIVE MOTION—MOTION OF STREAM FILAMENTS IN FRONT OF A BODY AT REST, EXPOSED TO A FLOWING STREAM— “ DUBUAT'S PARADOX ”

THE reader who has not thought much about the matter, will, perhaps rather naturally, presume that whatever is true when a *plate is in motion*, in *water at rest*, will be equally true when these conditions are reversed—i.e., when the body is at rest and the water *flows* past it.

Dubuat (*Principes d'Hydraulique*) says, in referring to this :

“ All those who have studied the resistance of liquids, have adopted as a first axiom, that the force capable of keeping a body at rest in a liquid in motion, was equal to the force necessary to move it with the same velocity in the same liquid at rest. This principle, without being proved, seemed at least so probable, that it was never doubted, and it was never considered necessary to verify it by experiment : but one often risks deceiving oneself, when one applies to fluids the laws of motion which apply to solids. *Is it not possible to believe that, in a state of rest, water offers greater facility in allowing itself to be divided, and consequently less resistance than when it is in motion ?* ” ¹ [Italics added].

¹ Tous ceux qui se sont occupés de la résistance des fluides, ont posé pour premier axiome, que l'effort capable de retenir un corps immobile dans un fluide en mouvement, était égal à la force nécessaire pour le mouvoir avec la même vitesse, dans le même fluide en repos. Ce principe, sans être prouvé, paraissait du moins si probable, qu'on n'en doutait pas, et qu'on n'avait jamais cherché à le vérifier par aucune expérience ; mais on risque souvent de se tromper, quand on applique aux fluides les lois du mouvement qui

Mr. Lanchester (*Aerodynamics*) referring to this says: "It is evident that the difference is merely one of *relative motion*. *The problems are identical*" [Italics added].

It is only fair to point out that, though he says this at page 16, at page 181 his view is quite different.

"The experimental basis of the law of the normal plane is two-fold; test of wind pressure at known mean velocity, and experiments on the resistance to motion of planes through still air. *At first sight there might appear to be no fundamental distinction between these two methods; the difference might be thought to be merely one of relative motion; owing, however, to certain considerations that require to be taken into account, the results obtained by the two methods are strikingly different, and the discrepancy in the value of the constant as given by different writers may be to a certain extent explained*" [Italics added]. It is not easy to see how these two statements can be reconciled.

So also Professor A. F. Zahm (*Scientific American Supplement*, July 20, 1912): "An important function of theoretical aerodynamics is to determine the velocity and stress of a fluid at every point of a medium *when it flows past an obstacle. . . . Equivalent results may be obtained if the object is assumed to move against the fluid, since only the relative motion is of consequence. This is regarded as self-evident.*" [Italics added]. This remark is the more extraordinary from Professor Zahm since he *refers to and defines* a static liquid: Mr. Lanchester does neither, that I am aware of.

The most emphatic writer, however, is M. Alexandre Séc (*Les lois expérimentales de l'Aviation*), for he says:—

"In virtue of the principle of relative motion, *these two cases are identical, and the results found should be the same.*" To this he adds, in a note, "*There have been experimenters who have not perceived this principle, who have believed it necessary to make experiments in both cases, and who, won-*

conviennent aux solides. Ne pourrait-on pas croire que, dans l'état de repos, l'eau offre plus de facilité à se laisser diviser, et par conséquent moins de résistance que quand elle est en mouvement, (Principes d'Hydraulique.)

derful to relate, have found *entirely different results*. Such is the case of Duchemin. . .”¹ [Italics added]. In parenthesis, I may add here that Duchemin was only following out the programme proposed by the *Académie des Sciences*; in which it was laid down that the resistances, etc., were to be measured *both when the body was at rest and the liquid was in motion, as well as when the body moved in still water*. Apparently the authorities of the *Académie* at that date were not prepared to assume that the *conditions were identical* —which they are not.

Such a remark from M. Alexandre Sée, is the more extraordinary, seeing that, in the early part of his book, he gives this very excellent advice: “In matters of aviation, *nothing is evident; everything is unexpected and paradoxical*. When you read in a work the word ‘evidently,’ or ‘it is evident that,’ be cautious and look carefully to see *if the author is not talking nonsense*.”²

Now, following M. Sée’s very excellent advice, let us examine this (?) “self-evident” proposition. What is the truth about this reversibility of the conditions? I believe the problems *are identical if all the conditions are identical*, but not necessarily otherwise.

To explain my meaning further, if a tank be filled with water the resistance encountered by a body moving *through this water* will be the same if (1) the *body is moving and the tank is at rest*, or (2) if the *tank be moved past the body at rest*. All the conditions here are identical: the liquid in *both cases* is a *static liquid*, and the relative motion is the same. I can conceive no reason why it should not be so—

¹ En vertu du principe du mouvement relatif, ces deux cas sont identiques, et les résultats trouvés doivent être les mêmes.

Note.

Il sont trouvés des expérimentateurs qui n’ont pas aperçu ce principe, qui ont cru devoir faire des expériences dans les deux cas. Et qui, chose admirable, ont trouvés des résultats entièrement différents.

Tel est le cas de Duchemin. . .

² Rien n’est évident, en matière d’aviation; tout est inattendu et paradoxal. Lorsque vous lisez, dans un ouvrage, le mot “évidemment,” ou “il est évident que,” méfiez vous, et examinez bien si l’auteur n’est pas en train de dire une bêtise.

mathematically it *should be so*—though I am not aware that the experiment has ever been tried.

If the water *flows* past the body at rest, the *conditions are different*: the liquid is *not* a static liquid. The results *might*, of course, be the same; but I see no *a priori* reasons for assuming that they *ought* to be so, and we must not be surprised if we find that they are different.

With this, I hope, not unnecessarily long preamble, I propose now to consider the results of some experiments bearing on this point.

In the last chapter we examined Duchemin's experiments with the thin square box, shown in fig. 24, when it was fixed to a boat. The same box was next fixed in a stream of running water and the same experiments were repeated: the results are given in the Table VI, which is *exactly* comparable with Table IV, of his experiments with the box fixed to the boat.

The first thing that will strike the reader is that in Col. 4, at the central hole, $\frac{H'}{h}$ is not 1.0, but 1.5—50 *per cent.* *more* than was the case when the *body was moving in still water*. It will also be seen that the readings at the holes 2 and 4 of the values of $\frac{H'}{h}$ are also *greater* than those found in Table IV, and that *this excess is also 0.5*. At the holes 3 and 5, on the contrary, the readings are *less by 0.5*. In consequence of this last, Duchemin added a unit to the value of $\frac{H'}{h}$, *so as to bring the results "into line."*

It is clear that if $\frac{H'}{h}$ for these holes was less than that of the others by $.5 + .5 = 1$, it was necessary to add a unit *somewhere*, if he wanted the results to all agree: it would have been just as easy to have added it to the values of $\frac{H'}{h}$

I am afraid one must confess that Duchemin's method appears a little arbitrary and hardly to be justified. We

must, I regret to say, find the gallant Colonel "guilty" of having cooked his Table VI.

TABLE VI
BODY AT REST

No. of Hole.	Value of h . Velocity Head.	Value of H^1 Potential Head.	Value of $\frac{H^1}{h}$.	Values of		
				e	$\frac{H}{h}$.	$\frac{4}{5}\left(\frac{H+H^1}{h}\right)$
	<i>m.</i>	<i>m.</i>		<i>m.</i>		
1	0.054	0.082	1.519	0.000	1.000	2.015
2	0.054	0.065	1.209	0.075	1.296	2.004
3	0.054	-0.005	-0.093	0.150	2.591*	1.998*
4	0.054	0.058	1.074	0.106	1.418	1.994
5	0.054	-0.018	-0.333	0.212	2.835*	2.002*

The values of $\frac{H}{h}$ have been calculated by the formula (a) adding one unit to those marked with a star in consequence of $\frac{H^1}{h}$ being negative.

Neglecting, however, the last three columns of this table and confining our attention to Cols. 1, 2 and 3, it is clear that the experiments show that, *whatever is happening* at the central regions of the plate is *not occurring at the edges*—in fact, *exactly the opposite effect* is to be observed there. The pressures, *except at the edge*, are all $0.5 h$ greater when the plate is at rest than when the plate is moving, whilst *at the edges* the pressures are $0.5 h$ less when the plate is at rest than when the plate is moving. Thus, it appears that *whatever it is* which is acting to cause *increased pressure* at the central regions of the plate, *ceases to act somewhere near the edge*: and then there is some other action which *reduces* the pressure at the edge by $0.5 h$. There is a *very rapid* fall in the pressure gradient near the edge of the plate, *when it is at rest*, and this pressure gradient is *much less steep* when the *body moves*. This rapid fall of pressure is generally explained by that very inelegant term "suction." This word *suction*, besides being inelegant, is likely to be

misleading as it rather *suggests* the liquid being under tension, which—except in very special cases—is absurd. In the last analysis all pressures in liquids are *positive*; and if they sometimes *appear* to be *negative*, it is simply because the datum line has been fixed too high—no account being taken of the *pressure of the atmosphere*, which is considerable. Whilst, therefore, I do not agree with the artifice employed by Duchemin, I have thought it best to leave his Table as he gave it, and simply to explain my reasons for disagreement. This particular question is of no special importance to my argument. I am satisfied to point out that the pressures at all the points, *except at the edges* are $\cdot 5 h$ higher when the *plate is at rest in flowing liquid*, than they are when the *plate is moving in liquid at rest*.

We also see in Duchemin's table that in the last column $\frac{H + H'}{h} = 2\cdot 5$ and not $= 2$ as in the former cases. The results are *clearly not the same*.

The greatest and most serious question which confronts us is, however, that we appear to have here a violation of one of our *fundamental assumptions*—the conservation of energy. It is clear that if H is a measure of the *kinetic* energy, whilst H' is a measure of the *potential* energy, and since, by assumption, $E_k + E_p = \text{constant}$, per unit volume of liquid, also $H + H' = 2h$, when the body is moving: we have an apparent *generation of energy*—*creation* of energy in fact, if it becomes $= 2\cdot 5 h$ when the *fluid is moving*—which is, of course, absurd. All the other difficulties are trivial compared to this; and if it cannot be explained, the whole theory crumbles to the ground. I will go into the question as thoroughly as I can later, but meanwhile we will examine the results of other experiments to see if they agree with those carried out by Duchemin.

Dubuat carried out exactly similar experiments to those of Duchemin: in fact, to state the case accurately, it was Duchemin who *carried out the same experiments as Dubuat*; he copied Dubuat and only repeated work which had been done half a century earlier. Dubuat's box was also of tinned iron, 1 foot square (old French measure, but *nearly*

=0.3 m.) and 4 lines thick, as against Duchemin's 0.03 m. It will be clear that the experiments are *very similar*: Dubuat's box was thinner, 0.33 inches as against 1.18 inches; his holes were smaller, 0.083 inches, as against Duchemin's 0.118 inches. The holes were similarly arranged, so that fig. 24 may be taken to represent both, and the method of measurement was the same. The results are given in

TABLE VII
BODY AT REST

No. of Hole.	Value of h Velocity Head.	Value of H^1 Potential Head.	Value of $\frac{H^1}{h}$.	Values of		
				e	$\frac{H}{h}$.	$\frac{4}{5} \left(\frac{H+H^1}{h} \right)$
	lines	lines				
1	21.5	32.8	1.525	0	1.000	2.020
2	21.5	27.8	1.293	36	1.320	2.090
3	21.5	20.8	0.967	62	1.551	2.014
4	21.5	-5.5	-0.256	72	2.640*	1.907*
5	21.5	-8.5	-0.395	101.8	2.905*	2.008*

The values of $\frac{H}{h}$ have been calculated by the formula (a) adding one unit to those marked with a star, in consequence of $\frac{H^1}{h}$ being negative.

Table VII, and are *exactly comparable* with those of Duchemin. All the remarks made about the last table are strictly applicable to this one, which may be said to speak for itself. The holes 4 and 5 were at the edge of the plate. This table, which is copied from Duchemin, also contains the artifice for holes 4 and 5 which I have considered as questionable.

Dubuat carried out an experiment which is somewhat similar to the foregoing; but there are differences which are certainly *very interesting*, and it is well worth bringing it to the reader's notice, as it confirms the results of the other experiments in a rather striking manner. In this case the box was only *partly immersed* (§ 442).

The box was 14 inches in height (French inches) and 12 inches in breadth. It was made of one inch boards and measured 12"×4" over all. The top was open so that the float could easily be seen (fig. 25). There were 13 holes bored in the front, as shown in the figure, of 6 lines ($\frac{1}{2}$ inch)

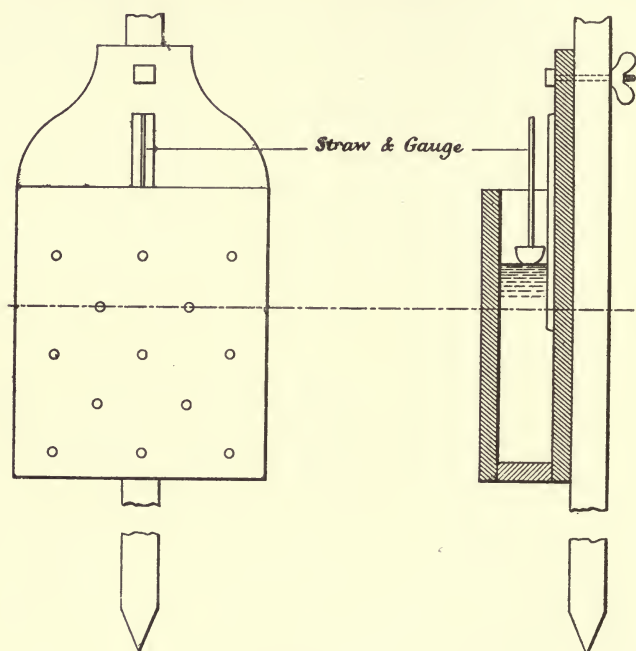

FIG. 25.

diameter. Fig. 25 will show the arrangement generally, and how it was fixed to the post driven into the bed of the stream. The box was immersed in the liquid to a depth of 8 inches 4 lines, and, as explained previously, when *all the holes were stopped*, a lip was formed in front of the box with a central height of 3 inches 7 lines, the lateral heights being 2 inches 9 lines only. The results, with different holes opened, are shown in Table VIII, which is *strictly comparable* with the two preceding ones. It will be seen that, at the central hole $\frac{H'}{h}$ is sensibly less than 1.5—though *consider-*

ably in excess of 1.0—this I am inclined to attribute to the size of the holes, which were, I think, too large to give the best results. The pressures at the last three holes were also lower than they would apparently have been, had the holes been smaller.

The chief interest in this experiment is that it shows that the *flowing stream* can sustain a very considerable head of water in the box—very much greater than is considered possible, theoretically—even when the holes are very large. These holes are not “pin-holes,” but are of such size that one can *put a finger through them*.

TABLE VIII

BODY AT REST

No. of Hole.	Value of h Velocity Head.	Value of H^1 Potential Head.	Value of $\frac{H^1}{h}$.	Values of		
				e	$\frac{H}{h}$	$\frac{4}{5} \left(\frac{H + H^1}{h} \right)$
	lines.	lines.		lines.		
1	29.33	40	1.364	16.00	1.142	2.005
2	29.33	37	1.262	27.40	1.238	2.000
3	29.33	36	1.227	34.60	1.307	2.027
4	29.33	29	0.989	39.50	1.351	1.872
5	29.33	18	0.614	78.90	1.702	1.853
6	29.33	25	0.852	44.00	1.391	1.794

The values of $\frac{H}{h}$ have been calculated by the formula (a).

This very curious and interesting point was first pointed out by Dubuat, more than a century ago, and is commonly spoken of as “Dubuat’s Paradox.” It is not commonly accepted, at the present day—possibly because it appears like a violation of the law of the Conservation of Energy—but I am not aware that any one has taken the trouble to *verify* the experiments of Dubuat and Duchemin. M. Eiffel (*La résistance de l’air*) says in reference to it: “Dubuat and even Duchemin, for example, have found by experiments with water that the resistance was not the same

according to whether the body or the water were in motion, This conclusion, which constitutes the *paradox of Dubuat*, is actually rejected by the majority of experimenters.”¹

Before proceeding to examine the question further, by the aid of other experiments, let us see what explanation, if any, Dubuat and Duchemin give of this “Paradox.”

Dubuat (*Principes d'Hydraulique*, § 454) says—somewhat laconically—“one sees that *the head due to the pressure against the centre of a plane surface, directly shocked, is equal to one and a half times that due to the velocity*; and this should be general, whatever be the size of the surface.”²

This can hardly be considered very satisfying; for though he says that this *should be the same, whatever the size of the surface* he gives no explanation why it should be. If we are told a thing should be, our first question is, naturally, *why should it be?*

There is a paragraph of Dubuat's (§ 425) which has some bearing on this subject, and which appears to show that he had some—possibly indistinct—idea why this should be so. Referring to the liquid filaments being deviated in front of the body at some distance away, he says: “If this deviation occurred in *all the filaments, at a distance, very great, relatively, to the extent of the surface, the shock would become insensible, which is not the case.*”³ Dubuat has an unfortunate habit of using the word “shock” in two senses, and there are times when it is not clear in which sense he is employing it. Dubuat was evidently well aware that Bernoulli's law is only true when there is no “shock”—in the sense employed by me.

¹ Dubuat et même Duchemin, par exemple, ont trouvé par des expériences sur l'eau que la résistance n'était pas la même suivant que le corps ou l'eau était mis en mouvement. Cette conclusion, qui constitue le *paradoxe de Dubuat*, est actuellement rejetée par la plupart des expérimentateurs.

² On voit que *la hauteur de pression contre le centre d'une surface plane, choquée directement, est égale à une fois et demie celle qui est due à la vitesse du fluide*, et ceci doit être général, quelle que soit la grandeur de la surface.

³ Si cette déviation avait lieu pour tous les filets, à une distance très-grande, relativement à l'étendue de la surface, le choc deviendrait insensible, ce qui n'est pas.

Duchemin is equally vague, for he says: "The explanations which I could give on this subject would be long without being completely satisfying."¹

So far we have no explanation of any kind. The few authors that ever mention Dubuat's Paradox are generally satisfied by saying that Dubuat's experiments were inaccurate; in fact, there is a story that a distinguished English civil engineer said at a meeting that he hoped Dubuat's experiments might be "decently buried": such arguments are of the poorest kind. Dubuat was notoriously a keen observer and a very good experimentalist. Why, then, should *all* his experiments made with a *body moving* give correct results—i.e. in accord with accepted theory—whilst *all* his experiments made with a *body at rest* should show an *excess pressure* at the centre of the body of 50 per cent.? If the experiments were bad ones we should expect *some* to be 10 per cent., or 15 per cent., or some other percentage in error. No! they are all—within the limits of experimental error—*exactly 50 per cent.* Even if we question the accuracy of Dubuat's experiments, how can we account for the fact that Duchemin, half a century later, repeated them; and got *exactly the same results*?

I think we may say that the point which is considered as "self-evident" (so self-evident that M. Sée considers it absurd to question, *much less to verify by experiment*), is not correct! Thus there is a great deal to be said for the famous "paradox of Dubuat."

In the next chapter I will refer to more experiments and quotations bearing on this subject, before offering an explanation of this curious question.

¹ Les explications que je pourrais donner à ce sujet seraient longues sans être complètement satisfaisantes.

SUMMARY

When a body is at rest in a flowing stream the pressures on the anterior surface are *not* the same as when the same body is moving at the same velocity in a liquid at rest. The pressures are considerably greater. There is evidently something to be said for "Dubuat's paradox." Whenever the liquid is a *static* one, the results obtained are always in accord with theory: when the liquid is *not* a static one, the results do *not* agree with theory.

REFERENCES

- F. W. LANCHESTER, *Aerodynamics*.
A. F. ZAHM, *Scientific American Supplement*, July 20, 1912.
S. ALEXANDRE SÉE, *Les lois Expérimentales de l'aviation*.
G. EIFFEL, *La résistance de l'air*, 1910.

CHAPTER VI

“ DUBUAT’S PARADOX ”—*continued*

THE question of “ Dubuat’s paradox ” being a very interesting, and a very important one, I must, even at the risk of being tedious, refer to all the experiments that I know of and which bear on the subject. The following is one of Duchemin’s.

If you place a Pitot tube with the orifice strictly normal to the line of flow of any liquid filament of a stream, the water rises in the tube to a level h (keeping to our old notation) which is called the “ velocity head.” If, however, this orifice is placed in the *centre of a small plate, the same result is not arrived at*: the liquid (*provided the plate is not too small*) rises to a level of $1.5 h$. Duchemin tried the experiment by placing small round discs round the aperture

TABLE IX
BODY AT REST

Diameter of the Discs.	Value of h Velocity Head.	Value of H . Kinetic Head.	Value of $\frac{H}{h}$.
m.	m.	m.	
0.003	0.057	0.057	1.000
0.01	0.057	0.081	1.421
0.02	0.057	0.855	1.500
0.03	0.057	0.86	1.509
0.05	0.057	0.85	1.492

of the tube and the results are given in Table IX. The orifice of the tube was 3 millimetres.

It will be seen that when this was placed in the centre of a disc, *only one centimetre* in diameter, the value of $\frac{H}{h}$ was 1.421. I need not remind the reader that one centimetre is *less than* $\frac{4}{10}$ of an inch—a very small disc. If the disc is increased to 2 centimetres, the value of $\frac{H}{h}$ increases to 1.5, and, very curiously, *further increase of the size of the disc does not increase the value of* $\frac{H}{h}$.

Dubuat (§ 436) describes a somewhat similar experiment. He made use of the flood gate of a mill race (Fig. 26) which was raised 5 inches and 9 lines above the sill of the race, this sill being nearly level on both sides of the gate: the opening was about four feet broad, and the head of water above the *centre of the orifice* was constantly 2 feet 1 inch and one line. A small plate (16 lines in diameter), and which had the point of a Pitot tube soldered into its centre—similarly to Duchemin's small plates—was presented to this running water, a *little below* the centre of the opening, so that there was always a head of 2 feet one inch and four lines *above the centre of the plate*, and about two or 3 inches distance between the plate and the sluice gate, so as to be about at the point of *greatest contraction of the fluid stream*. In this position, the water rose in the tube to a height of 2 feet 4 inches and 11 lines; that is to say, 3 inches and 7 lines *higher than the level of the reservoir* (fig. 26). (Dubuat gives no diagram, but the arrangement must have been somewhat as shown in fig. 26). This result would, generally, be considered an impossibility.

A somewhat similar experiment is referred to by W. C. Unwin (*Encyclopædia Britannica—Hydromechanics*):—

“Pitot expanded the mouth of the tube so as to form a funnel or bell mouth. In that case he found by experiment

$$h = 1.5 \frac{v^2}{2g} \quad ''$$

“The objection to this is that the motion of the stream is interfered with, and it is no longer certain that the velocity in front of the orifice is exactly the velocity of the unobstructed stream.”

The last paragraph is not quite clear; for it appears *quite certain* that the “velocity in front of the orifice” was *not* the “velocity of the unobstructed stream.” I think that the *real objection* is that, *theoretically*, h cannot exceed $\frac{v^2}{2g}$ —even when the fluid is at rest. Professor Unwin

does not give sufficient details of the experiment. I have not been able to verify this reference to Pitot; and I am inclined to think that he was quoting from memory and confused Pitot with Dubuat—whose experiments I will refer to later.

Whilst on the subject of Un-

win’s article on *Hydromechanics* in the *Encyclopædia Britannica*, I should like to draw attention to an extract, which has not, I think, received the attention it deserves. “Resistance of a plane moving through a fluid or pressure of the current on the plane.

“When a thin plate moves through the air, or through an indefinitely large mass of still water, in a direction normal to its surface, there is an excess of pressure on the anterior face, and a diminution of pressure on the posterior face. Let v be the relative velocity of the plate and the fluid,

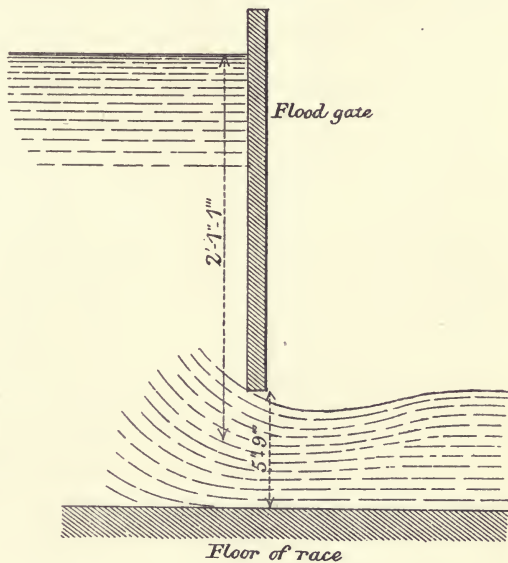

Floor of race

FIG. 26.

Ω the area of the plate, G the density of the fluid, h the height due to the velocity, then the total resistance is expressed by the equation

$$R = fG\Omega \frac{v^2}{2g} \text{ pounds} = fG\Omega h.$$

Where f is a coefficient having about the value of 1.3 for a plate moving in still liquid, and 1.8 for a current impinging on a fixed plate; whether the fluid is air or water. The difference in the value of the coefficient in the two cases is perhaps due to errors of experiment. There is a similar resistance to motion in the case of all bodies of 'unfair' form, that is, in which the surfaces over which the water slides are not of gradual and continuous curvature."

It will be seen that the formula $R = fG\Omega h$, where $f = 1.3$, when the body moves in still water, whilst it is 1.8, when the body is at rest and the liquid flows past it, corresponds to a difference of pressure of $0.5h$ —agreeing thus well with Duchemin's and Dubuat's experiments of pressure on the front of the plate. It appears to me to be rather a sweeping remark to say that "the difference in value of the coefficient in the two cases is perhaps due to errors of experiment." Might this difference not be due to the different conditions in the two cases?—one liquid being a static one, and the other not. I may point out that Professor Unwin when saying that "moving fluids, as commonly observed, are conveniently classified thus," . . . makes no reference to static fluids at all. This appears to me to be a serious omission, for if we do not recognize the difference between static and non-static liquids, we cannot arrange our facts; and we are perpetually coming across apparent contradictions.

Dubuat in his experiment No. CCXIV—which I cannot help thinking is the one that Professor Unwin ascribes to Pitot—states that he made a funnel of 3 inches base, with a tube bent at right angles to it of 16 lines internal diameter. At the apex of the cone of the funnel there was fixed a diaphragm which had a small hole of 3 lines diameter pierced in it. When he exposed this normally to a stream whose velocity was 36 inches per second, equivalent to a "velocity head" (h) of 21.5 lines, the water rose in the

tube to a height of 34.4 lines, which is *rather in excess* of $1.5 h$.

The same experiment repeated with the same funnel, but *without the diaphragm*, registered a pressure of 30.1 lines—which is *rather less* than $1.5 h$. In this latter case the aperture into the tube was too large to get a satisfactory result: it must be noted that 16 lines diameter is a hole *amply* large enough for the insertion of a tea-spoon.

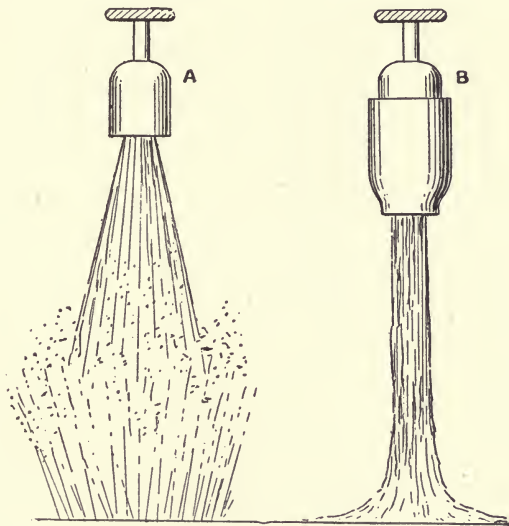

FIG. 27.

I will quote a statement of Professor Zahm’s which will make it clear *why* I have made special reference to the *size* of these holes. In the *Scientific American Supplement*, July 27, 1912, we find, when he is referring to the impact of a jet of water against a plate closing a hole in a tank, that he says:—

“Obviously, the fluid in the second tank may be sustained at any height whatever by force of the given jet, if the given plate be made to close an aperture *sufficiently small*. But in all cases it must be noted that, as formerly calculated [by Bernoulli’s Theorem] the *unit pressure at the centre of impact equals the pressure at the source*, so that

if a pin-hole be made there in the plate, the level in the second tank cannot exceed the level of the source" (Italics added).

This statement is, of course, equivalent to stating that *even if there were impact* the level of the liquid *could not exceed h* . Like many statements in Hydrodynamics this may be said to be true—and the reverse. If the *liquid in the jet is static*, then it is quite true—but not otherwise. Jets *very frequently behave* as if they were static liquids; though they would not be considered to come within the definition I have given previously. To give an example, fig. 27, which may be seen daily in many sculleries. The jet from the tap B, which has an "anti-splash" arrangement adjusted to it, *acts* as a static liquid does—*it will not splash*. The jet from the tap A clearly, does *not* act as a static liquid—*it will splash*.

This question will, I trust, be clearer when I have treated of jets and their resulting pressures.

Still another experiment of Dubuat. He made a small thin box of sheet-iron 1 foot square, one surface of which was pierced with 625 small holes, evenly distributed over it. This box was fixed in a current whose velocity, when undisturbed, at the centre of the plate was 36 inches per second—corresponding to a velocity head (h) of 21.5 lines. Attached, of course, was his modification of the Pitot tube, previously described. When *all the holes* in the box were open the liquid rose in the tube to a height of 28.3 lines: equivalent to about 1.33 h .

The same box was fixed in front of a cube, and was exposed to the same stream, also with all the holes open. The mean pressure against all these holes was measured as 29.2 lines.

The same box, having been placed in front of a "treble cube," mean pressure recorded was 28.4 lines.

Vince in his "Bakerian lecture" (*Phil. Trans.*, 1798) referring to this, says: "The subject divides into two parts: we may consider the action of *water at rest* on a body moving in it, or we may consider the action of *water in motion* on the body at rest." He found different results in the two cases, but I am not inclined to attach too much importance

to some of his results (*unless proper corrections are applied*), for some were obtained by whirling table experiments where the radius was *very small*—7.57 inches. As is well known, the coefficients obtained in such experiments would be *very considerably* in excess of what they would be if the body moved in a straight line. If we can trust Duchemin's formula, in some modern experiments even, a correction up to 45 per cent. is sometimes necessary.¹

So confused is the state of knowledge on this subject that it is not uncommon to come across passages like the following:—

“It will be seen that the value of K as determined by moving the Pitot tube through still water *differs very considerably* from that obtained in running water. In the latter case the pressure was *considerably higher* than in the former, and it appears therefore, that K depends *not only upon the form of the tube but upon the pressure under which it is working*” (F. C. Lea, *Hydraulics*).

I cannot explain what this paragraph is intended to convey, but it suggests (*to me*) that the Pitot tube is unreliable, and that its peculiarities are not at present explicable. It is certainly very curious that the statement fits in with what was said here previously; and it is *more* curious that such a very (?) unreliable instrument should have given such very accurate results in the hands of Dubuat and Duchemin.

Some writers go further than the above; Mr. William Kent, author of *Kent's Mechanical Engineer's Pocket-Book*, says frankly, that the “time-honoured formula $V = \sqrt{2gh}$ for the Pitot tube” is a *perfectly correct theoretical formula* when the *velocity is produced by the head*, but it is incorrect when the *head is produced by the velocity.*” (*The Pitot tube: Its Formula*, W. M. White.)

There are people who seem to think that a Pitot tube requires “calibrating,” for *every series of experiments.*

It is well known that M. de Grammont, when moving a

¹ See Eiffel's references to Von Lössl's experiments (*La résistance de l'air*, 1910).

plane through still air, has obtained results which *differ materially* from those observed by M. Eiffel, who fixes his plates in a stream of moving air. The consequence is that M. de Grammont's work does not meet with approval. M. Eiffel, even, referred the question of "relative motion" to M. Poincaré, who gave the following *very cautious reply* : " Il n'y a pas de raison pour que les efforts exercés sur des plaques par un courant d'air *bien régulier* [!!] différent de ceux que subirait cette plaque en mouvement dans un air calme."

I trust that this very long list of experiments will not have exhausted the reader's patience ; I shall have occasion

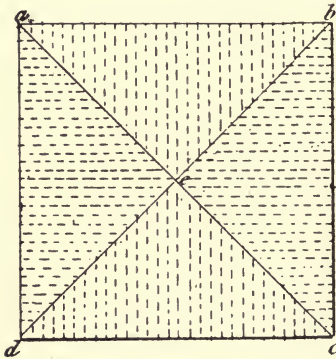

FIG. 28.

to quote some other similar experiments when treating of jets. I think now it will be clear that it is *not immaterial* whether the body moves in a liquid at rest, or the body is fixed in the midst of a flowing liquid. *All* the conditions are not identical, and experiments have shown that the *results are not the same*. I must defer my offered explanation of the reasons for this difference until after I shall have

treated of jets, so as not to distract the attention of the reader, and will now continue the examination of the motion of the liquid round the plate.

Having examined the motion of the liquid past the *front* of the plate at considerable length, it is necessary to study the velocity of the stream-filaments after they have *left the front of the plate*, and have resumed a direction of motion nearly parallel to their original undisturbed line of flow. For this purpose a square plate, 0.3 m. side, was employed. It was fixed in a flowing stream, the velocity of which, at the point *e*, the centre of the plate, was expressed by $h = 0.053$ m. : this centre *e* being at a depth, below the undisturbed surface of the stream, of 0.3 m. (fig. 28). A Pitot

tube was placed directly behind the edge bc with the orifice in a vertical plane 0.02 m. behind the front face of $abcd$. At the point b the water rose in the tube to a height of 0.105 m. At the point f the reading was 0.137 m. ; whilst at c the rise was 0.104 m. These heights of the water in the tube are those due to the velocity of the fluid-filaments—i.e., *measures of the kinetic energy* in these stream filaments. If we compare them with h , the velocity head of the stream, we see that they are about $2h$ for the points b and c , and $2.578 h$ for the point f .

Now if we calculate the velocity of the filament on arriving at f by the formula (a), putting $e = 0.15$ m., we find $H = 1.587 h$. If, therefore, we express the head due to the velocity of the filaments *after they have left* the surface by H'' , we find $H'' = H + h$. From which it follows that the head due to the velocity of the filaments, after they have left the edge of the plate, is increased by h , the velocity head of the stream.

These experiments were repeated at the anterior face of a cube and at that of a treble cube, or parallelopiped, having a length of 0.9 m., and the results were almost exactly the same as the preceding ; these are given in Tables X and XI. In the case of the square plate and the cube 0.3 m. side, the body was moving in liquid at rest ; whilst in the case of the “treble cube,” the body was at rest in the

TABLE X
BODY MOVING

Description of Body.	Value of h Velocity Head.	Dist. from edge of Body.	Value of H'' velocity head of filaments.	Value of H'' compared to h	Value of $\frac{H+h}{h}$.
Plane surface	m 0.045	m 0.020	m 0.116	2.586	2.587
Cube	0.042	0.020	0.109	2.588	2.587
do.	0.041	0.028	0.104	2.536	2.587

Square plate and cube 0.3 m. side. H in last column *calculated*.

TABLE XI
BODY AT REST

Description of Body.	Value of h Velocity Head.	Distance from Front Edge.	Value of H'' Velocity head of Filament.	Value of $\frac{H''}{h}$.
Parallelopiped 0.3m \times 0.3m \times 0.9m	m.	m.	m.	
	0.053	0.02	0.138	2.604
	0.053	0.32	0.134	2.526
	0.053	0.58	0.132	2.490
	0.053	0.88	0.131	2.472

Pitot tube placed 0.02m. from body at distances from the front edge given in column 3, and always at an equal distance from the top and bottom edges of the solid.

midst of a flowing liquid. It will be seen that the results are the same in both cases, making allowance for small experimental error which it is impossible to avoid in such kind of work. In the experiments with the treble cube, the distances of the point of the Pitot tube *from the front edge* were gradually increased from 2 centimetres up to 88 centimetres; the values of H'' diminished with this increase of distance. Evidently the velocity of flow of the stream-filaments *was being retarded*; and this retardation increased as the rear of the body was approached.

Now, since the velocity increases as \sqrt{h} , we see that, within the limits of speed experimented with by Duchemin, the velocity of the water flowing *past the edge of a plate, a cube, or a parallelopiped*, is roughly about 1.6 times the velocity of the undisturbed stream.

It is important, next, to try and find out *how far from the body* the water was *disturbed*. For this purpose a cube, of 0.3 m. side, was moved through still water, and the Pitot tube was fixed in a plane 2 millimetres *behind the front face of the cube*, but at different distances from the *edge of the cube*, as given in Table XII. In all cases the Pitot tube had its point situated exactly between the top and bottom

edges of the cube : in other words, it was on a level with the centre of the cube. The velocity head was measured by means of a separate tube, which was *well clear of the body*.

TABLE XII
BODY MOVING

Description of Body.	Value of h Velocity Head.	Distance from edge of Cube.	Value of H'' Velocity Head of Filaments.	Value of $\frac{H''}{h}$.
	<i>m.</i>	<i>m.</i>	<i>m.</i>	
Cube 0.3 <i>m.</i> side	0.046	0.02	0.118	2.570
	0.043	0.05	0.098	2.268
	0.041	0.10	0.071	1.730
	0.045	0.15	0.046	1.022
	0.043	0.25	0.042	0.980

Pitot tube placed 2 *mm.* behind the front surface of cube but at distances from the edge given in column 3.

An examination of this table will show that at about a distance of 0.15 *m.*—about *half* the length of the side of the cube—the value of H'' , the velocity head of these filaments (*referred to the cube*), fell to h , so that $\frac{H''}{h} = 1$. In other

words, at this distance the water was *undisturbed*. We may, therefore, expect that, at that distance, in a *static* liquid (*at the velocities experimented with by Duchemin*), what are called “boundary effects” will cease to be appreciable. We may reasonably imagine that the “water-cube” forms a complete “system” which travels in front of and alongside of the cube, and at the same velocity.

If this be correct, we can very simply check the velocity of the water past a plate, or the front edge of a cube, by means of a little very simple arithmetic.

Let us, for example, assume the plate to be circular and with a diameter = d . The sectional area of the disturbed column of water having a diameter = $2d$, will clearly be

four times that of the area of the plate. The annular space through which the water passes (fig. 29) has, therefore, a sectional area of *three times* that of the plate. Since the whole water in the cylinder whose diameter = $2d$ has to pass through this annular ring, its *mean* velocity will necessarily be $\frac{4}{3}v$, where v is the velocity of the undisturbed stream. Now, if we assume this mean velocity to occur at a point c , one-third of the distance from B to A; the

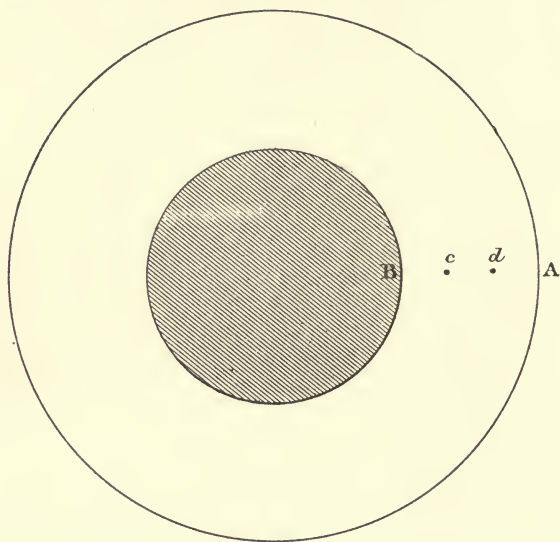

FIG. 29.

pressure gradient, as measured by the Pitot tube, is very nearly a straight line, so that the assumption made is probably not very far from the truth.¹ The velocity at A being v , the velocity at d will be $\frac{3.5}{3}v$, that at c will be $\frac{4}{3}v$; whilst the velocity at B will be $\frac{4.5}{3}v = 1.5v$. We see, there-

¹ There are reasons for believing that there is a rather abrupt fall in the pressure gradient *quite close to the plate*; this will not materially affect the calculation, which is, at best, but a *very rough approximation*.

fore, that the velocity of flow past B should not be *very different* from $1.6 v$.¹

To borrow a simile from Dubuat, the lines of flow of the stream-filaments will be not unlike those of a liquid flowing out of a cylinder which has a bottom as shown in fig. 30. The simile must not be pressed too closely, however.

SUMMARY

Dubuat’s Paradox may be expressed somewhat differently. If a body be exposed to a static liquid, the pressure on the centre of the body (greatest pressure) can never exceed h , the “velocity head.” If, however, the liquid is *not* static, this pressure generally increases by $.5 h$, to $1.5 h$.

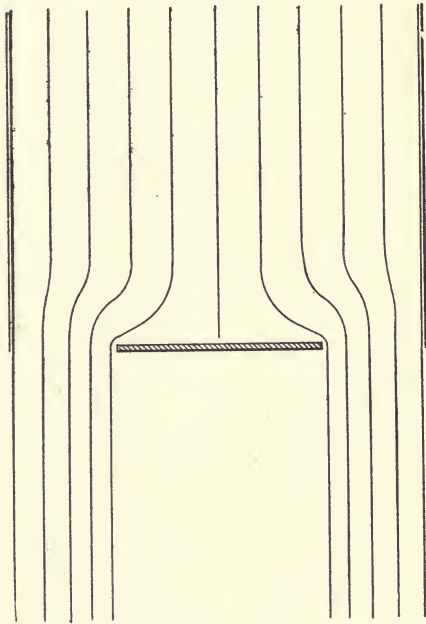

FIG. 30.

It appears, further, to be true that if a body, a cube say, moves through a static liquid, the cube and the water form a “system” which appears to be steady. The “cube-water system” is also much smaller than is frequently supposed.

REFERENCES

- Rev. S. VINCE, *Phil. Trans.*, 1798.
- G. EIFFEL, *La résistance de l'air*, 1910.
- F. C. LEA, *Hydraulics*.
- A. F. ZAHM, *Scientific American Supplement*, July 27, 1912.
- W. C. UNWIN, *Encyclopædia Britannica. Hydromechanics*.
- W. M. WHITE, *The Pitot Tube: Its Formula*.

¹ We know that in a non-viscous liquid, the velocity of flow past the circumference of a sphere immersed in it, can be calculated, mathematically, to be $1.5 v$.

CHAPTER VII

MOTION OF THE LIQUID AT THE SIDE OF A PLATE : ALSO MOTION BEHIND THE PLATE

KNOWING how the water flows past a rectangular parallelepiped it will now be interesting to examine the pressure exerted by it on the sides of the prism. For this purpose Duchemin adapted the small tin box, previously referred to, to the *sides* of a body 0.3 m. \times 0.3 m. \times 0.9 m., as shown in fig. 31, so that the hole which was opened

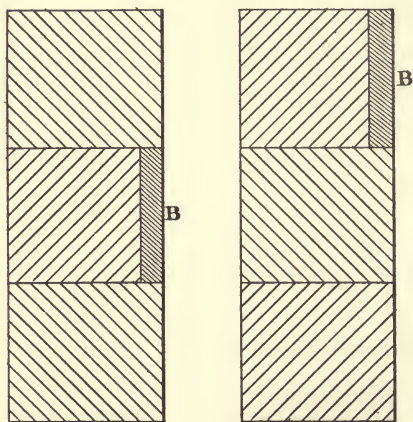

FIG. 31.

should be at *right angles* to the axis of the body, and at suitable distances from the front edge. These distances are the same as those given in the Table XI, in the last chapter; the results are therefore strictly comparable. It must be carefully noted that in the Table XI, H'' was the "velocity head" of the liquid

filament—was, in fact, a measure of its *kinetic energy*—whilst in this Table XIII, H' is a measure of the *potential energy* of these stream-filaments : $\frac{H''}{h}$ is taken from Table XI.

The results are given in the Table XIII, where Col. 1 gives distance from front edge of the prism of the reading

of the Pitot tube. Col. 2, velocity head of stream. Col. 3, the value of H' , the reading of the Pitot tube—the *measure of the potential energy* at this spot. It is clear that since $\frac{H'}{h}$ is a measure of the *decrease* of potential energy, and $\frac{H''}{h}$ is a measure of the *increase* of kinetic energy at this same point; then $\frac{H''}{h} + \frac{H'}{h}$ should be =zero. We see by the table that the pressure on a point on the side of the body increases, as the distance of the point from the front edge increases. An inspection of the last column will also show that there was no lateral “shock.” Since the pressures on the opposite sides mutually balance one another, it is clear that these *pressures* can in no way affect the resistance of the body to motion in the liquid.

In order to be quite sure of what we are doing, it is advisable to see whether the same results would be obtained if the conditions were reversed—i.e., if the body were in motion. Duchemin carried out two experiments in this manner, with a cube of 0.3 m. side, and having the small

TABLE XIII
BODY AT REST

Dist. of Orifice from Front Edge.	Value of h Velocity head of Stream.	Values of H' reading of Pitot Tube.	Values of $\frac{H'}{h}$.	Values of $\frac{H''}{h}$	Values of $\frac{H''}{h} + \frac{H'}{h}$.
<i>m.</i>	<i>m.</i>	<i>m.</i>			
0.02	0.055	-0.142	-2.582	2.604	+0.022
0.32	0.055	-0.142	-2.582	2.565	-0.016
0.58	0.055	-0.137	-2.491	2.490	-0.001
0.88	0.055	-0.135	-2.454	2.472	+0.018

Parallelopiped 0.3 m. × 0.3 m. × 0.9 m.
Axis immersed to a depth of 0.35 m.

thin tin box adapted to the sides. The results are given in Table XIV, which requires no special explanation, since

what was said about Table XIII applies equally to this: it is *strictly comparable* with it. In this case also, there is no appearance of any "shock" having occurred.

TABLE XIV
BODY IN MOTION

Dist. of Orifice from Front Edge.	Value of h Velocity head of body.	Value of H' reading of Pitot Tube.	Value of $\frac{H'}{h}$.	Value of $\frac{H''}{h}$.	Value of $\frac{H''}{h} + \frac{H'}{h}$.
<i>m.</i> 0.02	<i>m.</i> 0.063	<i>m.</i> -0.163	-2.587	2.588	0.001
0.28	0.059	-0.149	-2.525	2.536	0.011

Cube 0.3 m. \times 0.3 m. \times 0.3 m.

We have now examined the motion of water past a body immersed in it, in a very large number of ways. However the subject was turned or examined, we invariably found that, when the liquid was a *static* one, the sum of the *kinetic* and *potential* energies was constant; the errors being very small and only such as are to be expected in experiments of this kind. When, however, the liquids were *not* static, frequently large departures from the assumed constant values were apparent—such differences as it would be absurd to attribute to "experimental error." These departures were quite constant: they were *always in the same direction*, and the amount of the departure had all the appearance of being subject to some law.

It only remains now to complete the examination by inquiring how the liquid flows *behind the plate*, or body. We have seen that the pressure on the anterior face of a body moving *relatively* through a *non static* liquid was considerably greater than when the liquid was *static*. We cannot assume, without experiment, that *therefore* the *resistance* to a body by a non-static liquid was greater than that of a *static* one. The resistance can be measured only by the *differences of pressure* on the anterior and posterior

faces of the plate, say. If *both* pressures are increased equally, the *total resistance* will not be altered. Just as we found that the pressure on the front of a plate was not the same when the plate *moved*, as it was when the plate was fixed and the stream flowed past it—as (I hope the reader will say), when the *liquid* was “*non-static*”: so we must not be surprised if the flow, and therefore pressures, at the *back* of the plate differ in the two cases. The great instability of the eddies at the back of a plate makes it very difficult to measure velocities with any great accuracy. Duchemin says he found the difficulties so great that he contented himself with the measurements of the stream-filaments *directed towards the centres of the posterior surfaces*, the motion of these being stable as to direction. The results of the experiments are given in Table XV: the first three being for a thin plate, the next three for a cube, whilst the remainder are for double and treble cubes, as shown in the table.

TABLE XV

Relation between length and diameter.	BODY MOVING			BODY AT REST				
	Value of $\frac{h}{\text{Velocity Head.}}$	Value of $\frac{H'''}{\text{Velocity Head of Filament.}}$	Value of $\frac{H'''}{h}$.	Value of $\frac{h}{\text{Velocity Head.}}$	Value of $\frac{H'''}{\text{Velocity Head of Filament.}}$	Value of $\frac{H'''}{h}$.		
	<i>m.</i>	<i>m.</i>		<i>m.</i>	<i>m.</i>			
0	{ 0.052 0.048 0.046	{ 0.075 0.074 0.073	} 1.488	{ 0.055 0.055 0.055	{ 0.043 0.041 0.042	} 0.764		
1	{ 0.042 0.049 0.044	{ 0.056 0.065 0.069		} 1.333	{ 0.055 0.055 0.055		{ 0.052 0.052 0.054	} 0.961
2	{ 0.044 0.042 0.046	{ 0.052 0.051 0.053			} 1.180		{ 0.055 0.055 0.055	
3	{ 0.045 0.041 0.037	{ 0.044 0.042 0.040	} 1.024			{ 0.055 0.055 0.055	{ 0.0565 0.0565 0.056	

In order to understand this table properly, it will be necessary for me to make a small digression.

It will, I trust, be accepted that the effort necessary to retain a thin plate in a stream moving normally to its surface—or, conversely, to move a thin plate through a liquid at rest—can be measured by the difference between the *real* pressures which it sustains on its anterior and posterior surfaces. These pressures are composed of what is commonly called “static” pressure (pressure due to the depth of immersion; called by Dubuat, rather aptly, the “dead pressure”) which acts in all directions on the body; and what may be called the “live pressure,” which is caused by what is *commonly referred to* as the “shock,” or impact (I have carefully defined the sense in which I use the word impact or shock). If both the fluid and the body are at rest, the difference between these pressures is *nil*; the static pressure in front being balanced by that in rear. When the fluid moves, the pressure derived from the impact,¹ of which we have determined the intensity, must be added to the “dead-pressure” in front, and their sum will give the *real* pressure on the anterior side.

It is well known that, within certain limits, lengthening a body *diminishes* its total resistance: it was shown here, previously, that lengthening the body did *not* affect the *anterior pressure*. It is clear, therefore, that the diminution in the resistance, when a body is lengthened, *must, in some manner or another, be due to alterations in the pressure on the posterior face*: that, in other words, this pressure must *increase* with the increased length of the body, so that the *difference* between this and the anterior pressure may be *diminished*.

If, further, the liquid behind the plate “shocked” was moving *at the same velocity as if the plate did not exist*; as if (Dr. W. Froude would have said) the plate was a “phantom plate,” it is clear that the pressure on the plate would be the same both in front and in rear: the total pressure would be the *sum* of the *potential pressures* in all the stream filaments which strike the plate.

¹ Impact is here used rather loosely.

Even the *direction* of this motion is not very material, for if we imagine a body of liquid A (fig. 32) flowing towards a vertical plate whose plan is C D, at a velocity v , and then *disappearing* into that the mathematicians call a "sink"; if we, further, imagine another body of liquid B, also with a velocity v , flowing towards the plate in the opposite direction, and *also disappearing* into an imaginary "sink," it is clear that the *pressure* will be the same on both sides of the plate—and that the liquid pressures will not tend to move it in any direction. We might even imagine the plate to be formed like a thin box, and acting as a *real sink*, into which the liquid on both sides was *free to flow without being retarded in the least*.

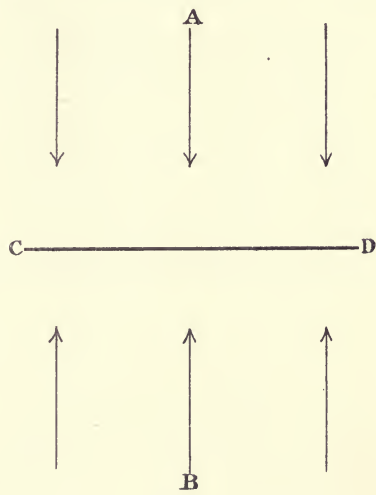

FIG. 32.

If any of the stream-filaments move *faster* than the general velocity of the stream, since $E_p + E_k = \text{constant}$, it is clear that the pressure, or *potential energy*, will be *decreased*, since the *kinetic energy* has been *increased*. Conversely, if the velocity

of any of the filaments is *less* than the general velocity of the stream, the *potential energy* or *pressure* will be *increased*, since the *kinetic energy* has been *decreased*.

Exactly the same line of reasoning will apply if we imagine the body to be moving. In the former case we referred all velocities to the *plate at rest*; whilst in this case we must refer all velocities of the liquid to the *plate in motion*. What we call a liquid "at rest," is, of course, a liquid *at rest referred to the earth*, as explained previously. If we refer the motion of a liquid at rest *to the plate in motion*, the liquid clearly has a velocity *towards the plate* which may be measured by h , the velocity head. In the same manner, a

filament of liquid following a plate at a velocity *equal to that of the plate through the water*, will have a velocity zero, when referred to the plate in motion. As before, if the filaments of liquid behind the plate moved at the same velocity (referred to the plate) as that of the general liquid in front, the static pressures would balance one another, and the resistance, if any, could only be caused by the "live pressure." Also, as before, if the stream filaments move *faster* than the general velocity of the stream (*always referred to the plate*), the pressure, or *potential energy*, will be *decreased*, since the *kinetic energy has been increased*.

Having, I hope, made this clear, let us now refer again to Duchemin's Table XV. Referring to the case of a plate moving in the water at rest, we see that in column 4, the velocity of the central filament, compared to the velocity head, or $\frac{H'''}{h}$, = 1.488; $\therefore H''' = 1.488 h$. This being greater than h , we should expect a *negative* pressure to be observed

TABLE XVI
BODY MOVING

Relation of length to Diameter of Body.	Value of h Velocity Head.	Value of H'' Pressure at Centre of Posterior Surface.	Value of $\frac{H''}{h}$.	Value of $\frac{H'''}{h}$ from Table XV.
	<i>m.</i>	<i>m.</i>		
0	{ 0.061 0.059 0.053	{ -0.034 -0.034 -0.028	{ -0.556	1.488
1	{ 0.055 0.057 0.049	{ -0.023 -0.025 -0.022	{ -0.435	1.333
2	{ 0.052 0.054 0.047	{ -0.016 -0.018 -0.0145	{ -0.313	1.180
3	{ 0.051 0.047 0.048	{ -0.008 -0.009 -0.0095	{ -0.186	1.024

at the *centre of the plate* and that this should be expressed as— $0.488 h$. Duchemin made the experiments necessary for measuring these pressures, the results of which are given in Table XVI. It must be admitted that the figures do not agree *very* closely, the *negative* pressures being, in all cases, more than 10 per cent. too great.

Since Duchemin gives no details of his method of conducting these experiments, it is difficult to judge why the figures disagree to such an extent. It appears probable, however, that the velocity of the stream filament was taken at too great a distance from the back of the plate. As this velocity is *being accelerated* it appears probable, therefore, that the real velocity of the filaments *at the surface of the plate* would have been rather greater than that measured and given by Duchemin in Table XV. One thing that comes out clearly is that the velocity of these central filaments *decreases* with *increased length of the body*, also that the *pressure* behind the plate *increases* (*measured positively, of course*) as the length of the body is increased. This being so, the *resistance* of the body—the *difference* between the anterior and posterior pressures, *both measured positively*—will *decrease* as the length of the body *increases*. It must be remembered that

TABLE XVII
BODY IN MOTION

No. of Experiment.	Velocity of Body.	Value of h Velocity Head.	Value of H'' Negative Pressure.	Value of $\frac{H''}{h}$.	Mean Values $\frac{H''}{h}$.
	inches.	lines.	lines.		
244	33.52	18.62	— 9.0	—0.483	—0.483
245	34.32	19.52	— 9.5	—0.486	—0.486
246	44.11	32.24	—16.5	—0.516	—0.516
247	54.90	50.00	—29.0	—0.580	} —0.580
248	55.89	51.77	—30.0	—0.579	

Body (not specified, but probably a plate) moving in water at rest—*approximately* only—as it was contained in a canal, but the velocity, if any, must have been inappreciable.

this is only true up to a length of about *three times the diameter of the body*: with a greater length than this, the resistance *increases* again slightly.

Dubuat measured this pressure behind a body—he does not specify the kind of body, but it was probably the thin box—and his results, given in Table XVII, are, generally, similar to those of Duchemin.

Another curious fact is shown in the Table XVII; that is that, $\frac{H''}{h}$ *increases — negatively — with the velocity*—as might, of course, be expected—and at a rather high rate.

TABLE XVIII

BODY AT REST

Relation of Length to diameter of Body.	Value of h Velocity Head.	Value of H'' pressure on centre of Posterior Surface.	Value of $\frac{H''}{h}$.	Body moving Table XVI. Value of $\frac{H''}{h}$.
	<i>m.</i>	<i>m.</i>		
0	0·057	-0·0339	-0·594	-0·556
2	0·057	-0·0175	-0·307	-0·435
3	0·057	-0·0115	-0·202	-0·313
3	0·057	-0·0105	-0·185	-0·186

Table XVIII (which is taken from Duchemin) may be compared with Table XVI, also from Duchemin, and shows the pressure in the centre of the rear of a flat plate, a cube, a double cube and also a treble cube. Column 5 is taken from Duchemin's Table XVI, and gives the values of $\frac{H''}{h}$ when the body is moving.

The accordance between these two sets of results is as close as one could expect in this class of experiment, with apparatus which was very rough. We see that the pressure behind a moving body *increases*—measured positively—as the body is lengthened. Why these pressures

should increase and how this is caused by the viscosity of the liquid, will be discussed at greater length when treating of that curious question which I call *negative resistance*—when viscosity actually *assists* in producing motion, or, put differently, *reduces the resistance to motion*: so that viscosity may be said to act as a recuperative engine which utilizes energy which would otherwise be wasted.

It will be necessary, in the next chapter, to make a small digression and treat of “jets,” the flow in which is somewhat different from that of a continuous liquid, which is only *partly* bounded by a free-surface. After this, the discussion of “Dubuat’s paradox” will be closed.

SUMMARY

Experiment appears to show that there is no *impact with shock* (as defined previously) on the sides of a body immersed in a liquid, whether (1) the body moves in a liquid at rest, or (2) the body is at rest and the liquid flows past it.

The pressure on the posterior surface of a body immersed in a fluid and moving in it, appears to be about the same whether the liquid is a *static* one or not. Since this pressure is apparently caused in a different manner, this can only be classed as a “coincidence,” and *not as a consequence*: more experimental results are required before this question can be decided satisfactorily.

REFERENCES

As before.

CHAPTER VIII

WATER FLOWING IN JETS—IMPACT

“ A JET is a stream bounded by fluid of a different kind.” (Unwin, *Hydromechanics*). Osborne Reynolds defined a jet as a stream *bounded by a free surface*. (*R. Inst.*, March 28, 1884).

When a stream issues from a hole in the wall of a tank, say, and this jet *strikes* a plate, the pressure that will be exerted on this plate will depend, very largely, on the momentum in the jet and which is communicated to the plate. If the jet has a cross-sectional area of one square unit, its whole pressure against the plate will be qv^2 , always provided that the plate be *broad enough* to stop all *forward velocity* of the fluid in the jet ; and, further, that the plate be *sufficiently distant* from the origin of the jet—since, if this distance be *not* sufficient, the pressure *may*, in certain cases, be even *negative*. If the breadth of the plate be insufficient, the transference of the momentum from the jet to the plate may be incomplete and the pressure on the plate may be *less* than qv^2 . It will be observed that this total pressure exerted by the flattened jet, is just *twice* that produced within a flowing stream, when its velocity falls to *zero* : in this case the whole *kinetic* energy has been converted into *potential* energy. Unwin (*Hydromechanics*) is in agreement with this ; only he says : “ But this pressure can *in no case* exceed $\frac{v^2}{2g}$, or h —measured in feet of water—, or the direction of motion would be *reversed* and there *would be reflux*. Hence the *maximum intensity* of the pressure

of the jet on the plane is h feet of water." This statement is, I think, far too sweeping to be considered as accurate. In the experimental investigation of this question, which he refers to, the jet issued from a hole in the bottom of a tank, and was allowed to fall on to a flat plate, perforated with fine holes. Experiments showed that in *no case* was the pressure, *per unit of area, greater than the velocity head.*

This might be considered conclusive; but it is not so. It is true *under these conditions*; but it is not difficult to devise conditions when it would *not be so.*

It will be remembered that in Chapter VI, I quoted Professor Zahm as stating much the same thing, viz., that "the *unit pressure at the centre of impact equals the pressure at the source.*" In *The Pitot tube: Its Formula*, we find

the same remarks, and these statements are based on experiments carried out in *exactly the same manner* as those referred to by Unwin. In *no case* was the pressure *greater than the velocity head h .* In all these cases quoted, the liquid *behaved as a static liquid*, and there was no "impact with shock" (in the sense defined by me).¹

If, however, a turbulent jet had been selected the results

¹ Dubuat described the liquid in such a jet as being "in equilibrium"—"*la vitesse d'une veine, qui sort par un orifice mince, est la même sur toute sa largeur*" this is equivalent to saying that the *pressure* is the same over the whole breadth.

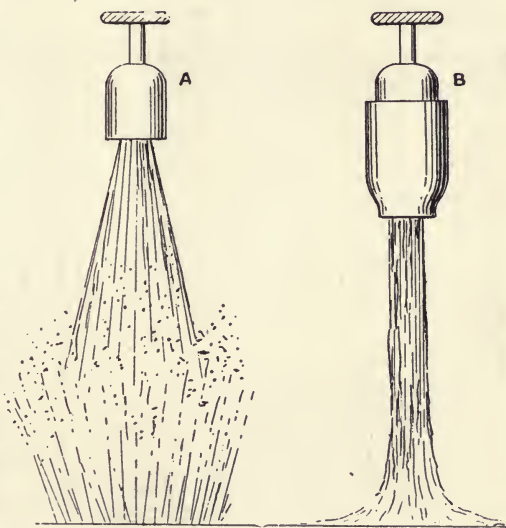

FIG. 33.

would have been different. To explain what I mean, if we selected a jet of water issuing from a lead pipe in connexion with the main, we should get a jet (fig. 33) which *splashed* considerably. By putting an "anti-splash" arrangement on the tap, this jet will be "tamed," and absolutely *refuse to splash at all*. In the second case it *acts as a static liquid*, whilst in the former it does not. The pressures caused by the two are very different—making every allowance for, and measuring the velocities of flow as accurately as possible.

Since most of the experiments I shall refer to were carried out so that the liquid *acted* as a static one, I am quite in

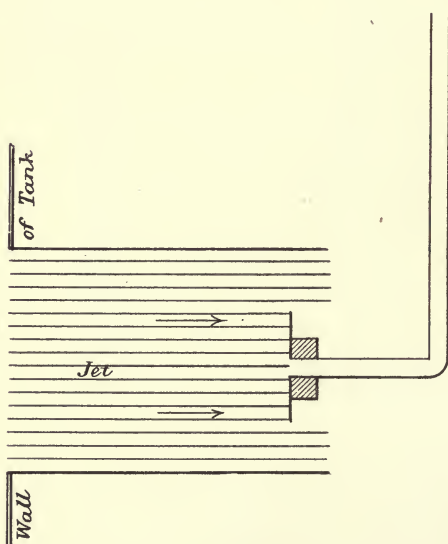

FIG. 34.

accord with Unwin and Zahm; but I make the reservation that their remarks *only hold with a static flow, or when the liquid acts as a static liquid*.

But to resume: Duchemin says that "amongst the causes which experiment has shown as lessening the intensity of the shock of a jet of water, the reduction of the area of the surface struck is that which produces the greatest effect."¹

If a jet issuing from a tank *acts* as a *static* liquid, the pressure at the centre of any body exposed to it should never exceed the "velocity head" *at the source*. Dubuat, as was explained earlier, exposed funnels, small plates, etc., to a *flowing stream* and *invariably* found that the pressure

¹ "Parmi les causes que l'expérience a indiquées comme amoindrissant l'intensité du choc d'une veine d'eau, la diminution de l'aire de la surface choquée est celle qui produit le plus d'effet."

exceeded the velocity head. The same experiments were conducted with jets in the manner now described. A glass tube of $1\frac{1}{2}$ lines bore ($\frac{1}{8}$ in. nearly) was bent at right angles, and was employed to measure the pressure, the different bodies experimented on being fixed to the point. Dubuat gives no diagram, but the arrangement must have been something like fig. 34. The jet was 2 in. in diameter, and issued from a circular hole made in a thin sheet of tin nailed to a large barrel, which was kept constantly full by means of boat pumps. The head of the water above the centre of the orifice was 1 ft. 10 in. 9 lines.

A small plate, 16 lines in diameter (fig. 34), with a small hole in the centre, was placed in front of the jet and a *few lines from the orifice* of the barrel: the water in the glass tube rose to a height of 1 ft. 10 in. 11 lines. This is 2 lines above the level of the "source." Dubuat explains this by drawing attention to the capillarity of the glass tube, which would raise the level of the water in the tube rather too high.

A small cylinder, 6 inches long and half an inch in diameter, was next substituted for the small plate in the last experiment, when the water rose, as before, 1 ft. 10 in. 11 lines.

A double cone (size not given) with a small hole, one-twelfth of an inch in diameter, pierced in one point, was next employed when the water rose to 1 ft. 11 in. 3 lines. If we here make the same allowance of 2 lines for capillarity, there is a small excess of pressure of 4 lines (one-third of an inch); this, as Dubuat explains, *might* easily have been caused by the workmen having pumped a little more vigorously than was necessary, and so caused the surface of the water in the barrel to have been slightly convex—thus increasing the head more than it should be. The difference is very small, being not much over *one per cent.* It is also quite possible—even probable—that there might have been a little air in the cone, which would have caused it to act like a "ram."

Sundry other small bodies were tried and the result was always the same; the pressure was *never in excess* of that caused by the "velocity head."

The double cone was presented to the jet, so that the

point was sometimes in the centre of the jet and sometimes at the edges ; the level of the water in the tube was the same in all cases. I wish to draw special attention to this, because there appears to be a difference of opinion on the question, as to whether the water flows *more rapidly* at the centre than at the edge of a jet, issuing from a hole in the thin wall of a tank. I think Dubuat's experiments show that the velocity was the same *all over the surface* of a cross section of the jet.

The experiments were then modified a little ; a 2 inch pipe being soldered to the tin plate of the barrel so as to make a *continuation of the opening*. When the small tin plate, employed previously, was presented to the centre of this jet, about $\frac{1}{4}$ inch from the orifice, the water rose 1 ft. 10 in. 11 lines—or to the same height as before.

The same plate was next moved back to 3 inches from the orifice ($1\frac{1}{2}$ diameters), when the water only rose to 1 ft. 9 in. 3 lines.

The double cone was presented to the centre of the jet, and subsequently at a small distance from the axis—the distance from the orifice was not observed—and in both cases the rise of the water was 1 ft. 9 in. 3 lines.

Having moved this double cone so that the point was within about 1 line from the edge of the jet, the water was found to rise to a height of only 1 ft. 3 in. 3 lines, thus showing that the velocity of a jet issuing from a *tube* is greater at the centre than at the edges. The importance of this observation will be evident later on.

The experiments were still further varied by the substitution of a tube of 7 lines diameter only ; the head of water above the centre of the tube being 12 inches.

The double-cone being presented to the centre of this jet and 6 lines from the orifice, the water in the tube rose to 12 in. 2 lines.

Dubuat observed that the level of the water in the tube fell when the axes of the jet and of the double cone did not coincide.

From the foregoing I trust the reader will have sufficient information to enable him to see that a jet issuing *quietly*

from an aperture in a thin wall of a reservoir acts as if it were a *static* liquid—in fact, quite similarly to the manner in which a liquid at rest acts, when a body is moving in it, at a uniform velocity.

I may be thought to have somewhat laboured this point, but I have done so intentionally. It is so commonly said that Dubuat's experiments are "unreliable," and I wished specially to show that *all the experiments under the same set of conditions agreed very closely*; and also all the experiments under *another set of conditions*; although the results in one set of conditions were not in agreement with those in the other. If one mixes up all Dubuat's experiments into one set, the apparent inconsistencies and contradictions are highly confusing—to express it mildly. Classified as they should be, the "inconsistencies" are capable of being easily explained.

Having shown that the *maximum* pressure per unit area of the surface of a plate struck by a jet does not, *ordinarily*, exceed the pressure at the source—I have specially said "ordinarily," for there are cases where this is not true, and where the pressure *can*, very much, exceed this initial pressure—we will next examine the *total* pressure caused by the jet.

As was said, previously, if a jet of unit section is moving at a velocity v , and the density of the liquid is Δ , then the momentum of unit volume of the jet will be Δv . But since v units pass any point per second, the total momentum passing this point *per second* will be expressed by Δv^2 , and the pressure on the plate can be calculated on the principle that all this momentum has been transferred to the plate.

The truth of the foregoing can be easily tested by allowing a jet to issue from the bottom of a tank, kept constantly full, and letting it fall on a flat scale pan; the pressure can be measured by putting suitable weights in the other scale pan: W being $=2\omega\Delta gh$, where ω = area of jet and h = velocity head. In making the calculations it is necessary, however, to make a trifling modification in this formula, to get the *real* pressure of the fluid vein. If h is the velocity

head of the liquid *issuing from the tank* (fig. 35), then the velocity of flow may be expressed by $\sqrt{2gh}$, during unity of time. But if a is the distance between the orifice and the

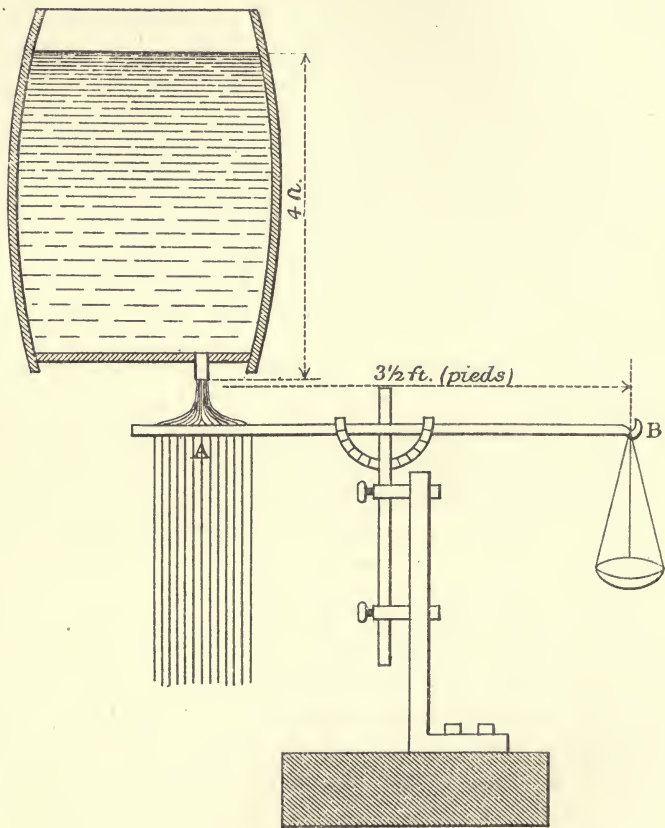

FIG. 35.

The fig. shows the apparatus employed and explains itself. Scale beam = $3\frac{1}{2}$ ft. (pieds). Head A C = 4 ft. (pieds).

surface of the plate, it is clear that the velocity with which the jet *strikes the plate* will be greater than this, being equal to $\sqrt{2g(h+a)}$. Since, however, the *mass of the liquid* will

be measured by the velocity of the liquid issuing from the orifice, or by $\sqrt{2gh}$, it follows that

$$W = 2\omega\Delta g\sqrt{h(h+a)}$$

where ω = section of jet, at the *vena contracta*

Δ = density of liquid

and g = gravity constant.

The Abbé Bossut (*Traité Théorique et expérimentale d'Hydrodynamique*) made the experiment in this manner and the results are given in Table XIX. It will be seen that the calculated and observed results agree very closely.

TABLE XIX

Diameter of Orifice.	Value of h Velocity head at Orifice.	Values of p .	
		By Experiment.	By Calculation.
Inches.	Inches.	Grains.	Grains.
0·8333	47	12608	12637
do.	23	6306	6285
0·500	47	4484	4549
do.	23	2243	2263

Old French measurements.

The apparatus is shown in fig. 35, which, I think, explains itself.

This question being undisputed it is not, perhaps, necessary to discuss it further.

When the jet is horizontal the above formula will, *apparently*, not be found to be correct. In this case, to satisfy the results of experiment, the weight W , which measures the pressure against a vertical plane, must be represented by the empirical formula

$$W = 2\omega\Delta gh\left(\frac{f}{f_1} + \frac{0\cdot0485h}{f_1}\right)$$

f_1 being the length of the lever at the extremity of which the weight acts, f the distance of the axis of the vein from the centre of rotation of the scale, and 0·0485 a constant

found by experiment. The sign “ + ” corresponds to the position of the axis of the vein, when it is *below* the axis of rotation, and the sign “ - ” to the opposite position. So that for the same jet the pressure is either greater or less, when measured horizontally, than it is when measured vertically. The reason for this will be easily understood if one considers how the fluid moves after striking the plate. The liquid travels away in all directions from the centre of impact : that part which moves upwards, falls back again,

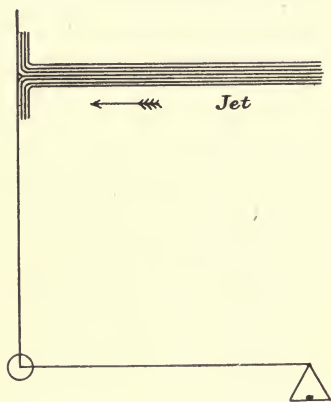

FIG. 36.

and so tends to shift the centre of pressure *below* the axis of the jet ; and in so doing *reduces* the length of the leverage. Obviously a smaller weight will be necessary to balance the blow of the jet (fig. 36).

If the jet strike the plate *below* the axis of rotation, the leverage will be *increased* and a *greater* weight will be necessary to balance the blow of the jet ; for this case imagine fig. 36 to be inverted and reversed.

Now referring to the value

$$W = 2\omega g \Delta h \left(\frac{f}{f_1} + \frac{0.0485h}{f_1} \right)$$

which corresponds to the position of the jet below the axis of rotation of the scale, the experiments of Michelotti (*Mémoires de l'Académie de Turin*, 1784 and 1785) give the results shown in Table XX, calculated by Duchemin. The agreement between the observed and calculated values of the pressure is very close—especially in the experiments with the circular jet. In the case of a square jet the measurement of the *vena contracta* is not as easy as with a circular jet. Fig. 37 gives, in diagrammatical form, the apparatus employed : here $AB = f = 30.305$ inches.

$CD = f_1$ (as in the table). Distance between the orifice

of the jet and the plate = 14.166 inches. Measures are old French measures and Paris ounces.

TABLE XX

Area of Orifice.	Head H. above the Centre of Orifice.	Values of f_1	Values of W .	
			Observed.	Calculated.
Sq. in.	Inches.	Inches.	Ounces.	Ounces.
1.0047	250.25	24.85	301.43	305.37
„	251.00	25.00	„	304.63
„	250.25	24.95	„	304.15
„	249.35	24.50	„	308.40
„	248.50	24.85	„	302.82
„	249.77	25.25	„	299.85
„	249.50	25.25	„	299.46
0.7854	250.00	20.05	„	301.34
„	250.00	20.09	„	300.66
„	250.25	20.07	„	301.33
„	250.45	20.09	„	301.33
„	249.50	20.01	„	301.21
„	248.50	19.93	„	300.90

Old French measures (Paris ounces).

The first seven experiments were with a square tube. Last six with circular tube.

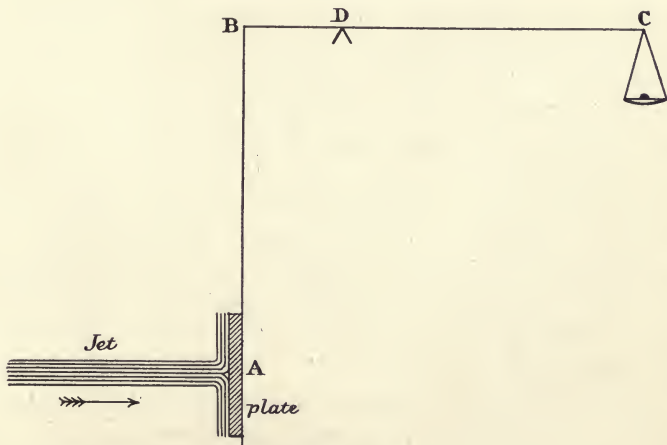

FIG. 37

It is worth while drawing attention to the beautiful simplicity of this apparatus : whilst A B is constant, C D can be varied at will.

It will, therefore, appear that if the jet strikes *below* the centre of rotation, the value of W will appear very considerably greater than the real value.

Now for the opposite case where

$$W = 2\omega\Delta gh\left(\frac{f}{f_1} - \frac{0.0485h}{f_1}\right)$$

which corresponds to the case where the jet strikes *above* the centre of rotation. I know of only one experiment which has been published, and that is by Vince in 1798 (*Phil. Trans.*, vol. 88). The object of his experiments was to find the value of the impact at different angles, so I select the value of W when the angle of impact is 90° . The jet issued from a horizontal tube and the discharge and velocity were checked by two methods :

(1) The bore of the tube was carefully measured as 0.045 inches and the discharge was calculated accordingly.

(2) The water in the tank was kept at a constant level, and the actual amount of the water flowing out during a certain time was measured ; the two results agreed very closely.

(3) The velocity was measured from the well-known properties of the parabola : the trace of the jet being marked on a board placed near to it, when it was not difficult to calculate the velocity of the jet.

I will not enter into any detailed description of the apparatus beyond saying that the level of the water above the nozzle of the tube was 45.1 inches ; and the distance between this nozzle and the plate struck by the jet was about 14 diameters ; $f=18$ inches ; $f_1=18$ inches. By experiment it was found that $W=1$ oz. 17 dwt. 12 grains, or 1.875 ounces (Troy). By calculation $W=1.880$ ounces (Troy), which differs but very little from the weight found by observation.

Vince, in his paper, makes no allowance for this alteration of the centre of impact, taking the *apparent* pressure as the *real* one : this leads to an error of nearly 12 per cent. He

finds the pressure = $\frac{900}{514}h$, whereas by Duchemin's formula it should be rather *more* than $2h$ —the error being only about *one-quarter per cent.*

The number of experiments referred to is small, as I know of no others; however, these are good ones: Bossut's and Vince's, in particular, are classical. It may, therefore, be considered as fairly well proved that when a jet *strikes* a plate, *normally*, the pressure on the plate corresponds to that of the *whole forward momentum of the jet*, having been communicated to the "earth-plate" system. It may be observed that the "correction" applied by Duchemin is, *in essence*, a certain addition to or subtraction from the weight—a certain percentage, say—which varies *with the velocity head*: i.e. with the velocity.

So far, the jet has been supposed to strike a *flat* plate, so that it has freedom to spread out laterally to any extent. Suppose, now, that we limit this freedom of motion: how will the pressure on the plate be affected? A little reflection will show that since the liquid will be "refluxed," or sent backwards, momentum of an equal and opposite amount will be generated, and that the pressure on the plate should be *doubled*. Instead of the pressure being represented by $2\omega\Delta gh$, it must be expressed by $4\omega\Delta gh$.¹

I know of no quantitative experiments on this point, except a reference in d'Aubuisson's *Traité d'Hydraulique* to some experiments of Morosi. He observed the action of a jet on a horizontal plate, and found the pressures could be balanced by weights of 5, 7 and 9 *livres*. He then fixed, on the four edges of the plate, small borders which projected 0.014 m. above its surface. On repeating the experiments he found the pressures caused by the jet had augmented so that weights of 11, 15 and 20 *livres* were required to balance them: that is to say, *more than doubled*. This increase over the theoretical amount may be explained, if the experiments are to be relied upon, *and if Duchemin's formula (a)*

¹ This is, of course, the fundamental hypothesis on which the kinetic theory of gases is based.

is as true for jets, as it appears to be for the ordinary flow of a liquid.

If we suppose fig. 38 to represent, diagrammatically, the jet striking the plate at the point A, B and C being the small projecting ledges; it is clear that the velocity of the liquid-filaments at B and C will not be v , the velocity of the jet, but $v\left(1 + \frac{e}{K}\right)^{\frac{1}{2}}$. The momentum generated backwards will

therefore not be measured by Δv^2 , but by $\Delta v^2 \left(1 + \frac{e}{K}\right)$;

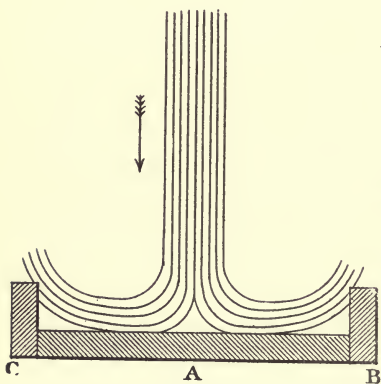

FIG. 38.

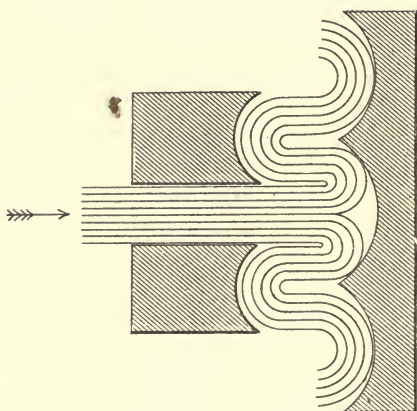

FIG. 39.

and the *increased* impactual pressure may be expressed as

$$W = 2\omega\Delta gh\left(1 + \frac{e}{K}\right),$$

and the *total* impactual pressure will be

$$W = 2\left(2 + \frac{e}{K}\right)\omega\Delta gh.$$

There is also another reference to Morosi in Ruhlman's *Hydromechanik*, where the experiment is somewhat different. The plate struck was as in sketch (fig. 39), where the water was refluxed on to a concave ring and then sent back again on the plate. In this case he found the pressure was about $3.5\omega\Delta gh$: the theoretical amount should be $4\omega\Delta gh$, but

a great deal of energy must have been converted into heat, and, apparently, lost.

SUMMARY

A jet issuing from a tank of *still water* appears to *act* as a *static* liquid, in that the *maximum* pressure on any unit of the surface it may strike will never exceed the *pressure due to the height of the source*.

In measurements of pressure caused by jets in striking plates, it is very essential that the plate receiving the pressure should be *large enough*. The distance of the plate from the nozzle of the jet must also be *sufficient*, since if it is *too close*, the pressure caused by the jet may even be *negative*. When there is reflux the pressure is doubled.

REFERENCES

JOSEPH T. MICHELOTTI, *Mémoires de l'Académie de Turin*, 1784 and 1784.

REV. S. VINCE, *Phil. Trans.*, vol. 88.

D'AUBUISSON, *Traité d'Hydraulique*.

ZULIANI, *Idraulica di Venturoli*.

NAVIER, *Architecture hydraulique de Bélidor*.

CHAPTER IX

JETS STRIKING A PLATE AT AN ANGLE—DUCHEMIN'S FORMULA
—DORHANDT AND THIESEN'S FORMULA—JOESSEL'S
FORMULA—M. DE LOUVRIÉ'S FORMULA—M. GOUPIL'S
FORMULA—COLONEL RENARD'S FORMULA—VON LÖSSL'S
FORMULA

WHEN a jet of water, whose section, density and velocity are ω , Δ and u , meets a fixed plane at an angle α , it is generally admitted in works on Hydraulics that the normal pressure supported by the plane may be expressed by $\omega \Delta u^2 \sin \alpha$, that being the amount of momentum which is supposed to have been transferred to the "earth-plane system" in the direction of original motion. If the jet be *very small*, experiment appears to confirm this. In the experiments of Vince (*Phil. Trans.*, 1798), previously referred to, the small jet was caused to strike a plate at different angles; the jet always moving horizontally and striking the plate at angles *measured horizontally*. It was shown previously that when the angle of impact was 90° the pressure might be expressed by $\omega \Delta u^2$; now, since the experiments at all the angles are *strictly comparable*, it will only be necessary to examine the weights put into the small scale pan for different angles, to see if they vary as $\sin a$. The results, taken from Vince's paper, are shown in Table XXI. As Vince says: "It hence appears that the resistance varies as the sine of the angle at which the fluid strikes the plane; the difference being only such as may be supposed to arise from the want of accuracy to which the experiments must necessarily be subject." To this must be added, *provided that the jet be very small*; without this qualification Vince's

TABLE XXI

Angle of Impact.	Comparison of Theory and Experiment.					
	Experiment.			Theory ($W_a = W_{90} \sin a$).		
	oz.	dwt.	gr.	oz.	dwt.	gr.
90°	1	17	12	1	17	12
80°	1	17	0	1	16	22
70°	1	15	12	1	15	6
60°	1	12	12	1	12	11
50°	1	8 ¹	10	1	8 ¹	7
40°	1	4	10	1	4	2
30°		18	18		18	18
20°		12	12		12	19
10°		6	4		6	12

statement is certainly not justified. *Because* it is correct for a *very fine jet*, is no argument for assuming that it would be equally true for a large one. In cases like these you are *not justified* in extrapolating; nor in building a *general law* on the foundation of a special experiment. The reasons for this statement will appear later.

If we examine the experiments made by the Abbé Bossut, the results appear not to be in accord with Vince's. Referring to fig. 35 in the last chapter, we have Bossut's diagram of his method of carrying out the experiments. The jet was, as before, vertical, and struck the scale pan as shown; the experiments now referred to having been made at an angle of 60°. In order to make the results strictly comparable with those obtained when the impact was normal, the beam of the scale was raised, so that when the pan was inclined at 60° to the jet, the *head of water* was the same as in the experiments previously referred to. When the beam was horizontal, the weight required to balance the pressure of the jet was 12,608 grains. It is clear that when the beam is inclined at 60° to the *vertical*, while the weight is acting vertically, its "leverage" will have been reduced from W to $W \sin 60^\circ$. Since the momentum of the jet is the same as it was before, it is clear that if the *normal pressure* varied

¹ 18 dwts. in the paper : an obvious misprint.

as the sine of the angle, it should now balance the $W \sin 60^\circ$; in other words, the same weight, 12,608 grains, should be required in the scale pan to produce equilibrium at all angles. Such was not found to be the case; the weight required to be placed in the pan was only 12,248 grains, about 3 per cent. less than this theory would appear to require.

It might be thought that this experiment decided the question; but this is by no means the case. Although the Abbé Bossut took very great pains that the centre of the jet should be exactly over the correct part of the scale-pan, the centre of the jet will not, in this case, be the centre of pressure of the jet; and this has to be allowed for. If the formula of Lord Rayleigh, previously referred to, is applicable to a jet, the "divide" will have been shifted so as to reduce the leverage by about 5 per cent. *Per contra*, however, the centre of pressure will have been shifted "down hill," as explained previously when speaking of jets striking vertical plates horizontally. Until we know the exact amount of each of these shifts it is not possible to say what this experiment proves, or what it does not prove.¹ There are, however, other reasons for thinking that this "sin law" is not strictly accurate, although at very small angles the error is almost negligible.

Probably the first author who treated of this subject was Duchemin. By an ingenious train of reasoning he came to the conclusion that the $\sin a$ (for jets) should be modified to $\frac{2 \sin^2 a}{1 + \sin^2 a}$; but when applied to bodies moving in large

volumes of liquid, he modified this to $\frac{2 \sin a}{1 + \sin^2 a}$, this latter formula being commonly spoken of as "Duchemin's formula." This formula is very well known, being found in most books, but I am afraid that the majority of the authors are but imperfectly acquainted with Duchemin's *Les lois de la résistance des fluides*; I fancy their information is

¹ If we examine it by Lord Rayleigh's formula for position of centre of pressure $\left(x = \frac{3}{4} \frac{l \cos a}{4 + \pi \sin a}\right)$, the decrease of the weight should be about 4.2 per cent.

chiefly derived from Langley's great work. One author, for example, speaks of it as an "empirical formula," which it certainly is not. It agrees with the results of *some* experiments—notably with Langley's, as he pointed out—but it requires some *very heavy corrections* to bring it in line with

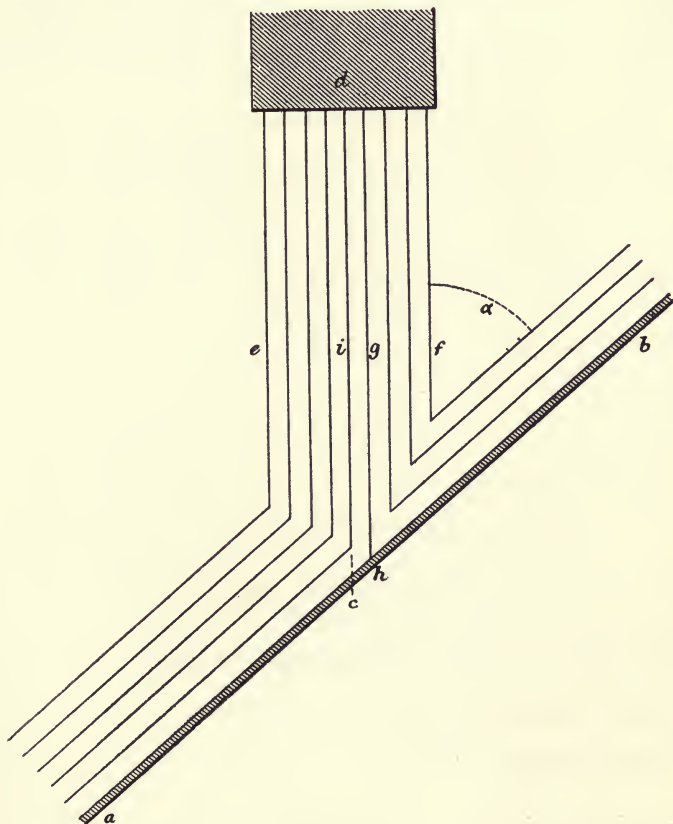

FIG. 40.

the results of others. It is not exactly satisfying, and I am inclined to think that this, is *chiefly* due to the assumption of the " \sin^2 law." I propose, therefore, substituting a modified type of this formula, based on the same train of reasoning as Duchemin's, but without this " \sin^2 " assumption.

Now, following Duchemin's line of argument, let fig. 40 represent, diagrammatically, a jet of water striking a plane ab at an angle α . dc is the centre of the jet, the projection of whose section ω is ef , and gh the dividing line of the jet; eg that portion β , of the section ω , the molecules of which pass along the slope ha of the surface ab ; gf , the other portion γ , of the same section ω , containing the stream-filaments passing along the slope hb of the surface ab . We have therefore

$$\beta + \gamma = \omega.$$

The pressure exerted, normally, on ah will be as before, $=\beta\Delta u^2 \sin \alpha$ ⁽¹⁾; whilst the pressure on hb will be $=\gamma\Delta u^2$. The total pressure p on the plate will therefore be

$$p = \beta\Delta u^2 \sin \alpha + \gamma\Delta u^2.$$

Now since the reactions of these flows must be equal and opposite, gh being the "divide," it follows that

$$\beta\Delta u^2 \sin \alpha = \gamma\Delta u^2,$$

and since $\beta = \omega - \gamma$, we may, by first eliminating β , and then γ , get

$$\gamma = \frac{\omega \sin \alpha}{1 + \sin \alpha}, \text{ and } \beta = \frac{\omega}{1 + \sin \alpha}$$

From this we may express the total pressure on the plate as

$$p = \frac{\omega}{1 + \sin \alpha} \Delta u^2 \sin \alpha + \frac{\omega \sin \alpha}{1 + \sin \alpha} \Delta u^2$$

$$\text{or } p = \frac{2 \sin \alpha}{1 + \sin \alpha} \omega \Delta u^2.$$

It will be apparent that this formula $\frac{2 \sin \alpha}{1 + \sin \alpha}$ is of the same type as, and closely resembles, the Kirchhoff-Rayleigh formula $\frac{\pi \sin \alpha}{4 + \pi \sin \alpha}$; for it is only necessary to change the *unit* in the denominator to $\frac{4}{\pi}$ for it to become $\frac{2 \pi \sin \alpha}{4 + \pi \sin \alpha}$.

It will be clear that this formula is *not* an empirical one; nor can it be pretended that it is exactly new, for several authors have employed it, with variations. For example, Dorhandt and Thiesen used it in the form of

¹ Duchemin in his reasoning assumes $\sin^2 \alpha$, instead of $\sin \alpha$; this is, I think, unsound.

$$\varphi = \frac{2 \sin i}{1 + \sin i} \left(1 - \frac{0.62 \sin i}{1 + \sin i} \right)$$

where the "correction" is, as far as I am aware, purely empirical.

JOESSEL'S FORMULA

Joessel modified the constants, I presume also empirically, until he got the form

$$\varphi = \frac{\sin i}{0.39 + 0.61 \sin i}$$

The reader will have observed that in Duchemin's line of argument, which I have here adopted, no allowance has been made for "reflux" of the liquid. Since *some* reflux actually occurs, the formula is, at best, but a first approximation to the truth. The formula for the pressure on the plate must be changed from

$$p = \beta \Delta u^2 \sin a + \gamma \Delta u^2 \text{ to } p = \beta \Delta u^2 \sin a + \gamma X \Delta u^2$$

where $X > 1$, (when there is *no* reflux, $X = 1$,) being a measure of the *increase* of pressure due to the reflux.

By following the same calculations as on page 104 we get

$$p = \frac{2X \sin a}{X + \sin a} \omega \Delta u^2$$

where Duchemin's formula is changed to

$$\frac{2X \sin a}{X + \sin a}$$

M. DE LOUVRIÉ'S FORMULA¹

M. de Louvrié, assuming that X might be represented by $(1 + \cos a)$, modified the formula to

$$\varphi = \frac{2(1 + \cos a) \sin a}{(1 + \cos a) + \sin a}$$

This is a curious formula which has a *maximum* at about 60° or 70°. Such a maximum was actually observed by M. de Grammont de Guiche on his plates moving through still air.

¹ I do not know this work of M. de Louvrié; my authority is Eiffel's *Recherches expérimentales sur la Résistance de l'air*.

M. GOUPIL'S FORMULA

This is generally found in the form of

$$\varphi = 2 \sin i - \sin^2 i,$$

having all the appearance of being an empirical one. It can, however, I think, be shown to be a *rational* one, where the assumption has been made that the reflux is perfect: that is to say, that X in the equation $= 2$.

Inserting this we get

$$\varphi = \frac{2 \times 2 \times \sin i}{2 + \sin i}$$

which is equal to $2 \sin i - \sin^2 i$, omitting all terms involving higher powers of $\sin i$ than the square.

KIRCHHOFF-RAYLEIGH FORMULA

This well known formula takes the shape of $\frac{\pi \sin a}{4 + \pi \sin a}$ and is based on the rather arbitrary assumption that the flow of the stream *past the plate* is the same as that of the undisturbed stream at a distance. No ordinary fluid moves like this: it would be dangerously near "perpetual motion."

COLONEL RENARD'S FORMULA

This, like Goupil's formula, looks like an empirical one; but it appears to have been derived from Duchemin's formula $\frac{2 \sin i}{1 + \sin^2 i}$ by assuming that the reflux was perfect, so that $X, = 2$.

Making the necessary change we get $\varphi = \frac{2 \times 2 \sin i}{2 + \sin^2 i} = 2 \sin i - \sin^3 i$, omitting all terms involving higher powers of $\sin i$ than the cube.

There are several other formulæ, but they are less well known and are generally very empirical. There is one, however, which is thought very highly of in Germany, which is $\varphi = \sin i$, simply: this is the formula of Von Lössl.

VON LÖSSL'S FORMULA

Von Lössl verified the accuracy of this formula by a very interesting direct experiment.

A rectangular wooden frame was mounted on the arm of a whirling table so that it could turn freely about the whirling arm. It was 1 m. long, 25 cm. broad, and carried two small planes of 500 cm.² area mounted symmetrically to the axis the frame turns on. One of these planes was fixed in the plane of the frame, whilst the other was free to move, and to be fixed at any inclination to this plane. When the whole system was set in motion, the frame assumed the same angle to the horizon as that of the surface of the small plane

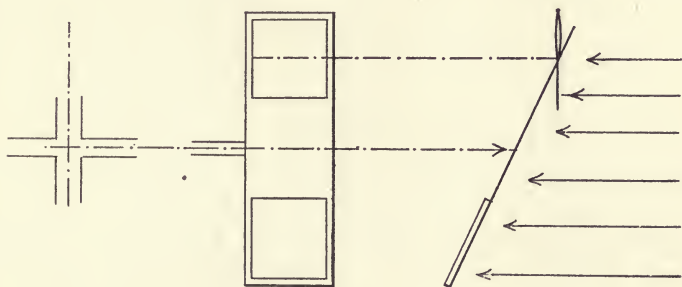

FIG. 41.

with the plane of the frame (fig. 41). This could clearly only be the case if the moments of the pressures about the axis were equal; that is to say,

$$P_i \times d = P_{90} \times d \sin i,$$

whence $P_i = P_{90} \sin i,$

P_i being the normal pressure on the inclined plane, and P_{90} the pressure on the plane moving in normal presentation.

The experiment is highly interesting, but it can hardly be said to give a conclusive result. If the centre of pressure of the plane inclined to the line of motion were *at the centre of figure*, it would be more satisfactory; but such is not the case, it being nearer the axis than the centre. There must also undoubtedly be a shifting of this centre of pressure "down hill," or *away from the axis*. Whirling table experiments are further open to grave suspicion. The experiments appear, however, to have been carried out with quite especial care.

None of the foregoing formulæ—considered as rational formulæ—can be applied to the resistance of plates moving in a fluid, since they only refer to the pressure on the *leading face* and do *not* apply, in any way, to the negative pressure experienced at the back of the plate. The agreement between Duchemin's formula and Langley's experiments can therefore only be considered to have been accidental.

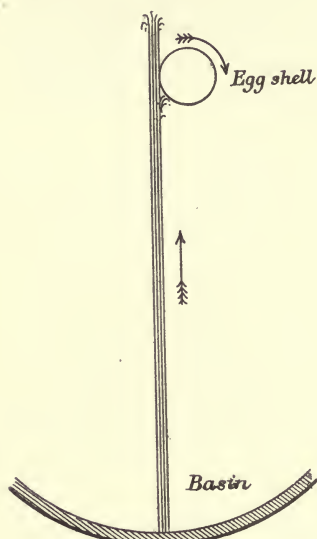

FIG. 42.

Even the *particular part* of a narrow plate which a jet strikes may affect the amount of the resistance which is observed. Vince, in his Bakerian lecture, describes how he carried out a series of experiments with a narrow plate, but on repeating them he got *quite different results*. He repeated them a third time, and got *different results again*. At last he found out that the differences were caused by the jet having struck the plate—at the same distance from the axis

—*but sometimes at the centre, and sometimes near the "leading" or "trailing" edges.*

Further, it must not be assumed that a formula which gives true results *down to* 10° will give equally correct ones at smaller angles. I believe that, at *very small* angles, these formulæ will *all* give incorrect results. Vince found in some of his experiments of a jet striking a plate, that the pressure exercised by the jet was actually *negative*. It is well known that there is a mutual attraction between a jet and a solid. If the solid is heavy the jet moves towards it; whilst in other cases, with light solids, the jet can actually *attract* them.

A well known example of a jet attracting a light solid is to be seen in almost any shooting gallery at a fair, where a small fountain jet supports a blown egg-shell. The

velocity of the liquid so reduces its pressure (according to Bernoulli's law) that the egg is pressed by the atmosphere against it. The egg tends to roll down the jet, and so rotates whilst being drawn up it.

Exactly the same effect can be produced with an air-jet, as was shown by Sir James Dewar at the Royal Institution Juvenile Lectures, Christmas, 1912, with a ping-pong ball and a powerful air-jet. That the jet *attracts* the ball, and does not merely *strike* it, and so support it, can be shown by *moving the jet about*, when the ball invariably *follows this movement*.

SUMMARY

Pressure caused by the impact of a jet on a plate appears to vary (*when the jet is very small*) as the sine of the angle of impact. If the jet is large, the relation would appear to be more nearly as $\frac{2X \sin a}{X + \sin a}$ where $a =$ angle of impact; or by some other formula of this type.

REFERENCES

- S. P. LANGLEY, *Experiments in Aerodynamics*.
Lord RAYLEIGH, *Scientific Papers*.
H. S. HELE-SHAW, *The Motion of a Perfect Liquid*.
D. RIABOUCHINSKY, *Institut de Koutchino* III.
Von LÖSSL, *Luftwiderstandsgesetz*.
G. EIFFEL, *La résistance de l'air*.

CHAPTER X

EXPLANATION OF "DUBUAT'S PARADOX"—THE "ADDED MASS"—OSCILLATING PRESSURE"

WE have seen that the pressure on the face "in normal presentation" of a plate exposed to a stream, is greater when the plate is fixed than when it is moving in a liquid at rest. How can this be?

Two explanations might be advanced.

(1) It might be due to what is well known as the "added mass": I will quote Professor Zahm to explain what I mean. "Another general theorem asserts that when the above hypothecated frictionless fluid moves past a solid with *accelerated speed . . . there is always a resistance, and this is directly proportional to the acceleration.* Commonly, the fluid resistance in accelerated motion can be expressed by merely *endowing the moving object with a certain additional mass.*" (Italics added.)

This description is hardly likely to convey a clear impression to the ordinary reader; and as the subject, though highly important, is not referred to in any textbook that I am acquainted with, I will give an illustration in connection with the oscillation of a pendulum in a liquid.

The properties of pendulums swinging in a vacuum are treated of in every book on elementary mechanics. As is well known, the time occupied by each swing can be expressed by the very simple formula $T = 2\pi\sqrt{\frac{l}{g}}$, where T = time, l = length of the pendulum, and g = acceleration due to gravity; the time varies *as* the square root of the length of the pendulum, and *inversely* as the square root of the

force of gravity. Hence it is clear that the *length of a pendulum*, corresponding to a given time of vibration, varies *directly as the force of gravity*. If, therefore, a body be placed at such a distance from the earth that its “gravity” or weight be reduced by one-third—the force of gravity having been reduced by this amount—the length of the pendulum at this place would require to be reduced by one-third, for the oscillations to take place in the same time as they would at the surface of the earth. If, then, the body, *remaining on the earth*, is of a density such that when it is plunged in water it loses *one-third* of the weight which it would have *in vacuo*, it will be the same case as if it were removed to the distance from the earth, previously referred to. The “mass” of the pendulum is the same in both cases, the only variable being gravity. Hence if we put a to represent the length of the pendulum which oscillates in any given time *in vacuo*: l the length of the pendulum which oscillates in the same time in the fluid; p , the weight of the bob in the fluid; P , the weight of the fluid displaced by the body; $P+p$ will express the weight of this body *in vacuo*, and $\frac{P+p}{p}$ will be the relation between the forces of gravity in the two cases. We shall have, therefore, the equation,

$$\frac{P+p}{p} = \frac{a}{l}; \text{ and hence } l = \frac{ap}{P+p}.$$

Now it might be imagined that this formula would enable us to find the correct length of the pendulum. This is not so, nor would it be correct if the liquid were a “perfect” liquid, since its velocity, as well as the direction of its motion, *referred to the pendulum*, is constantly changing.

It might reasonably be asked if the resistance which the liquid opposes to the body would not disturb the isochronism of the oscillations, and in destroying a part of the gravity, necessitate the further shortening of the pendulum more than is required by the preceding law. The mathematical explanation of this would be beyond my ken, and certainly beyond the scope of this small book. We may, however, examine the question in a simpler manner and by reference to experiment.

When a pendulum oscillates *in vacuo*, the accelerating force diminishes *positively* during the descent to the lowest point of the arc described by the pendulum, where it becomes *zero*. It then increases *negatively* during the ascent on the other side, until the body has arrived at the same height that it originally started from. But, if the oscillation be executed in a fluid, the resistance will continually destroy a part of this accelerating force, which will be reduced to *zero before the pendulum reaches the vertical*. It is there it attains its *maximum* velocity, and this point will be the *middle of the oscillation*.¹ The whole oscillation will, therefore, be diminished approximately by *twice* the distance that the half oscillation was diminished. This loss of amplitude indicates the *effect* of the resistance—without it being necessary that the time should vary from this cause. In fact, if the resistance reduced the time of the oscillations, the pendulums of great swing would oscillate more slowly than those of small swing, which we know is not the case, since experiment shows that the times are sensibly equal. We know, further, that water contained in a syphon oscillates at a rate which depends strictly on the *length* of the syphon, and in no wise with any reference to the *size of its cross-section*, which would affect the resistance. It may be laid down that the *resistance* which a body *experiences in oscillating* in a fluid, and the *time of these oscillations*, are two effects which have no *immediate relation*, and that they *do not depend on the same cause*.

The preceding formula would give exactly the length of a pendulum in a fluid, *if the body in moving did not draw with it a certain quantity of the fluid*, which quantity appears to vary very little at different velocities; so the *mass of liquid in movement* does not consist only of the *mass displaced by the body*, but also of some “added mass” which the body *draws along with it*, and which is practically constant for different velocities. If therefore we take n , a constant number, so that np may express in all cases the weight of the fluid displaced, *together with that of the fluid drawn along*, the

¹ The effect is, in fact, as if *the direction* of the action of gravity had been shifted through a small angle.

weight of the total *mass in movement*, i.e., *its weight in vacuo*, will no longer be equal to $p + P$, but will be represented by $p + nP$; whilst its weight in water is always expressed by p . It is necessary, therefore, to change the formula to

$$l = \frac{ap}{nP + p} = \frac{a}{\frac{nP}{p} + 1}, \text{ from which we get}$$

$$n = \frac{p}{P} \left(\frac{a}{l} - 1 \right).$$

Dubuat made very many experiments on this subject, and found n practically constant for all diameters, weights and lengths of pendulums, being rather more than 1.5. The “added mass” in these cases was therefore equal to about *half the mass of the liquid displaced by the moving body*.¹

Although I cannot help thinking that there is some connection between this and Dubuat’s paradox, I am unable to consider the explanation quite satisfying. I am, even, rather inclined to think that this may be putting the cart before the horse. May it not be possible that “Dubuat’s paradox” might explain the “added mass.” The “50 per cent.” addition gives serious cause for reflection!

(2) It may be due to impact *with shock* of the fluid—in the sense previously defined by me, and *implying reflux*—such reflux being partial and not *complete*, as when a non-static jet strikes a plate.

The cautious reader will at once say I am here contradicting myself. Having so much insisted that *there is no impact with shock*, that a liquid *cannot strike a body immersed in it* and which completely surrounds it, I now wish to explain a series of experiments by suggesting that the liquid *can strike it*. What becomes of the theory that when the liquid

¹ Sir George Stokes, referring to this, says that “added mass” for a sphere of radius a , moving in an envelope of radius b , and displacing a mass of fluid m will be

$$\frac{b^3 + 2a^3}{b^3 - a^3} \cdot \frac{m}{2}$$

to which he adds: “Poisson came to the conclusion that in an *elastic fluid the envelope would have no effect*” (*Math. and Phys. Papers*. Italics added).

is at rest the added pressure can be measured by the "velocity head" h ?

Most unfortunately, in Hydrodynamics there is hardly a statement which can be made that is *absolutely true in all cases*. It is best—or I have thought it so—to make *general* statements, and later to try and correct any small errors, in fact, to point out the *exceptions*.

In treating of the motion of liquids there are two ways of approaching the subject. We may *assume impact with shock* and follow what is commonly, though I think *erroneously*, called the "Newtonian system"; or we may follow what I may call "Euler's system," which leads us to "stream lines," etc., etc.

The assumption of impact with shock leads to such absurdities that we may rule it out. We are therefore reduced to the Eulerian system, on which all the mathematics of the subject are based.

Now, what are the *assumptions*, or *fundamental hypotheses*, in this theory? (1) "Continuity" of the liquid; this, if not *absolutely assumed*, is provided for by supposing the liquid as of *infinite dimensions*. It is quite evident that if a liquid occupies *infinite space* any discontinuity is unthinkable, since it would necessitate the liquid occupying *more than infinite space*. I have dealt with this at considerable length in the *A B C of Hydrodynamics*, to which the reader is referred.

(2) The second assumption is that *there is no impact with shock*. This also, if not stated in so many words, is provided for by the supposition that the fluid is of *infinite dimensions*. A little reflection will show that impact with shock is *not possible if no particle of the liquid can move without another particle moving away to make room for it*.

Are we then to think that the Eulerian theory is not confirmed by experiment? That, in fact, "the forms of flow that result from the assumption of continuity and the equations of motion bear in general but *scant resemblance to those we obtain in practice*?" (Lanchester, *Aerodynamics*.) By no means; but *we must be careful that we do not put "peascods" into the mathematical mill*. We must not *assume*

that what is true for a liquid *which has no free surface* is equally true for *one which has*. We must not assume that what is true for a *static liquid* is equally true for one *which is not static*. In short, *we must not extrapolate*.¹

We have seen, by experiment, that when a body of water is *static*, the mathematical formula giving the relation between *potential* and *kinetic* energy is verified; but that when a liquid, *with a free surface*, is *flowing past* a body at rest, this *appears* not to be true. We found that the pressure at the centre of the body could no longer be measured by the velocity head h , but that it was *increased*, and was equal to $1.5h$. This was found to be *invariably* the case in all Dubuat’s and Duchemin’s experiments, for bodies of *all* shapes, including funnels, hollow cylinders, thin plates, etc., etc. The only exceptions being when the liquid flowed as, what I may call, a *quiet jet*, when the liquid appeared to *act as a static liquid*. It was pointed out in Chapter V that if this increase of pressure at the centre of the plate were caused by an increase in the *potential* energy of the liquid, then *energy must have been created*. As this is unthinkable, and is, in fact, barred by the assumption of the conservation of energy, it is clear that the only explanation left is that there must have been *impact with shock*. Since “reflux” would, as we have seen previously, imply that the pressure should be increased from h to $2h$, it is clear that the reflux must have been periodic, vibratory, or wave like, causing intermittent “reflux” and “non-reflux” movement.

Now if we express the potential energy of the liquid at

¹ Dr. Hele-Shaw has shown, *experimentally*, that in a *viscous liquid, without a free surface, all bodies are stream-line*. Lanchester defines a “stream-line body” as “*one that in its motion through a fluid does not give rise to a surface of discontinuity*.” This definition appears to be imperfect, for the facts seem to be, *both for viscid and inviscid liquids*—

(1) In a liquid having *no free surface (the envelope being inextensible) all bodies are stream-line*.

(2) At *very low velocities, all bodies are stream-line—under all circumstances*.

(3) In a liquid *with a free surface, the bodies moving at a reasonable velocity and moderately near the free surface, no bodies are stream-line*.

A *compressible fluid* is, clearly, similar to one enclosed in an *elastic envelope*.

the centre of a body as H' , or h ,—since the *kinetic* energy has here been reduced to *zero*—and the extra pressure caused by the reflux as h , it is clear that, when reflux is perfect, the pressure at the centre of the plate will be $H' + h$, or $2h$; whilst when there is no reflux it will be h only. As shown in fig. 43, we may describe the pressure as $h, 2h, h, 2h$, etc.; so that the *mean* pressure at the centre of the plate will be $1.5h$, as was shown by experiment. At a distance from the centre, the *potential* energy, still expressed by H' , will be *less* than h , and the pressure may be described as $H', H' + h, H', H' + h$, etc. The mean pressure at this point being $\frac{H' + (H' + h)}{2} = H' + .5h$; this is also in accord with Dubuat's

and Duchemin's experiments. Near the edges of the plate this reflux action appears to cease, and the pressure is then measured by H' only.

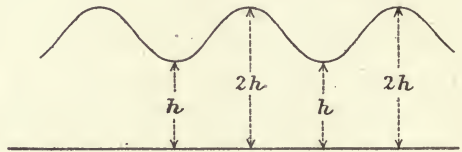

FIG. 43.

To make my meaning perfectly clear, I will explain myself by giving different diagrams of the flow of liquids.

In fig. 44 is represented the flow of a *static* liquid past a body, where there is *no* reflux. The reader who has not seen this diagram before will probably think this is a *drawing* of the flow of a perfect liquid past an obstacle. It is nothing of the sort; it is a *photograph* of the *actual flow* of that very highly viscous liquid glycerine. This is reproduced, by permission, from the *Motion of a perfect liquid*, and I have Dr. Hele-Shaw's authority for stating that this photograph is *untouched* and *accurate*. It is clear that, *the conditions being the same*, this viscous liquid flows as the mathematicians tell us a perfect liquid would flow: the curves are very beautiful, and well worth a careful study. This flow, having taken place between sheets of glass about $\frac{1}{50}$ th of an inch apart, is clearly one in *two dimensions* only; and so, not exactly the same as it would be in *three dimensions*. For my argument, only the upper half—in front of the

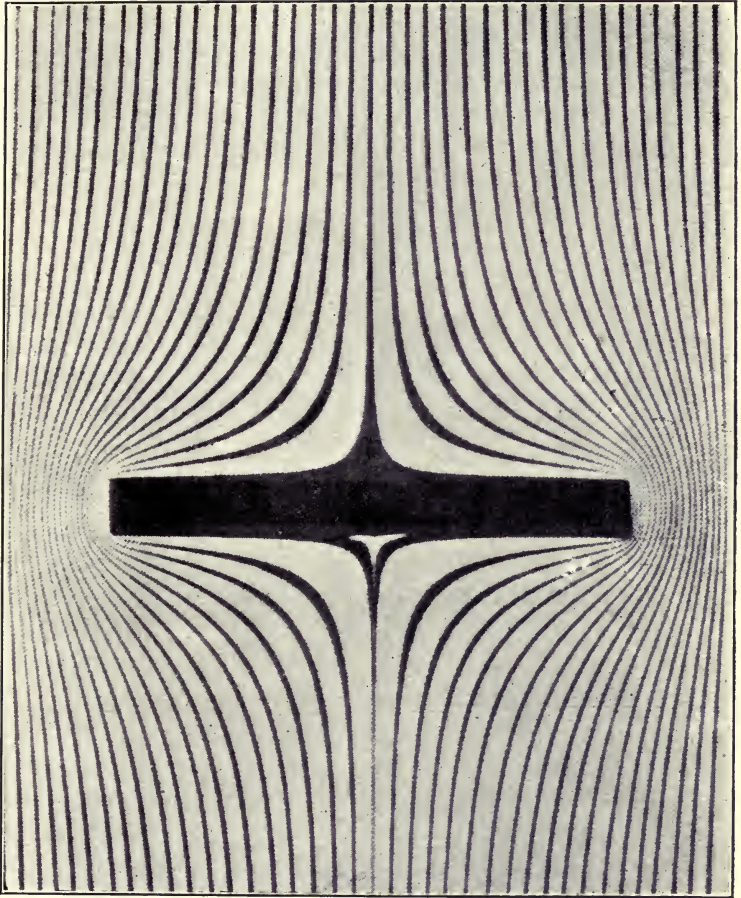

FIG. 44.

N.B.—This is a reproduction *from a reproduction*—hence the small spots, caused by the grain of the paper.

plate—is to be considered ; *there is no sign of any reflux.*

Fig. 45 represents diagrammatically the flow of a *non-static* liquid in front of a body at rest. As will be seen, in the centre there is a small enclosed body of water thrown into a kind of wave motion, alternately moving away from and towards the plate. The reflux is here clearly indicated.

All this appears perfectly clear and simple ; but it is all based on the *assumption* that there is reflux. Will experiment support this view ?

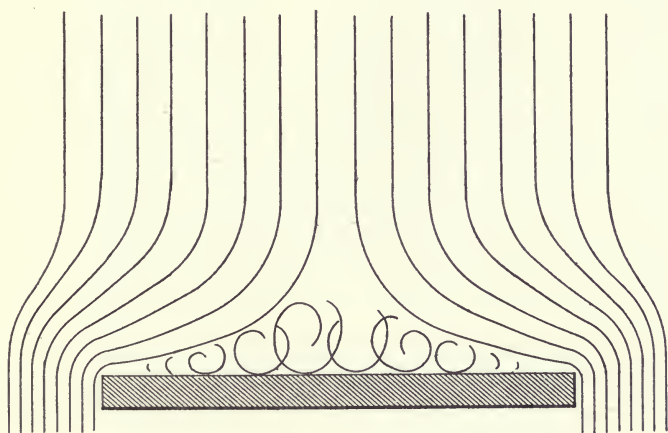

FIG. 45.

I know of no author who has photographed stream lines of water flowing past bodies except M. Marey. His photographs, however, are very small ; and though there appear to be distinct signs of reflux in places, the evidence is not such as to be very convincing. Dorn’s photographs were taken when the bodies were in motion in water at rest, and so are of no use for my present purpose. The photographs taken at the National Physical Laboratory, though also showing signs of reflux, are very small and not quite satisfactory. If, however, we refer to the research work done on air, and if we assume—as is generally done—that the movement of air is similar to that of water, we have plenty of material to work on.

Riabouchinsky (*Koutchino, Fascicule III*) made many experiments with air flowing past bodies of very many shapes; the air having been rendered visible by the employment of lycopodium powder, some very beautiful photographs were taken of the stream-filaments. In every case there is distinct evidence of *vibratory movement* of the air *in front* of the bodies.

Fig. 46 is a reproduction of a singularly fine photograph by Dr. Hele-Shaw. The vibratory action is well indicated in front of the body; and the vortex, on the right, behind

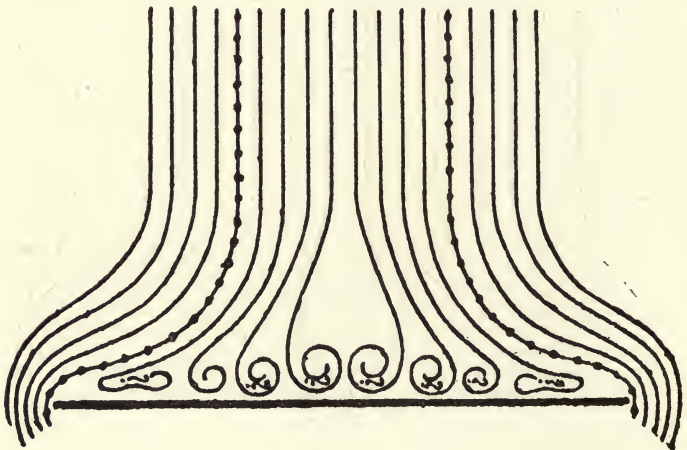

FIG. 47.

the plate is particularly well shown. Even the vortex action behind the plate appears as if it were of an oscillating character.

It has been objected to me that since, in these experiments, the plate of sheet iron on which the lycopodium was resting was given a sharp blow with a hammer at the time the photograph was taken, this vibratory movement may have been caused by the blow of the hammer. I am not inclined to attach much importance to this objection, since the vibration caused by the blow was perpendicular to the direction of motion of the air: the vibratory action is also non-apparent *behind* the plate, or other body. The evidence is by no means, however, confined to these photographs.

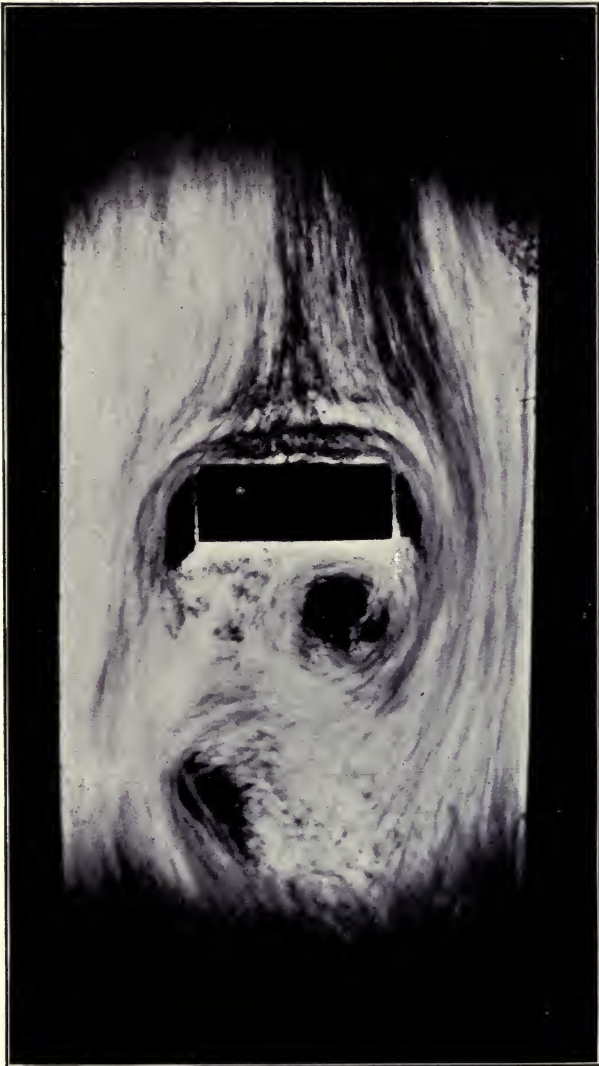

FIG. 46.

Lilienthal studied this question, and his diagrams of stream lines show this reflux *most clearly*. Von Lössl ((*Luftwiderstandsgesetz*), who supported Lilienthal’s view, gives the same form of diagram of flow of air past a plate. Fig. 47 is a copy of Von Lössl’s diagram, which I may describe as Lilienthal’s simplified; there can be no doubt that reflux action is here indicated.

I might quote several other authors in support of this, but I will confine myself to one whose evidence is incontestable—M. Eiffel. In *La résistance de l’air*, 1911, we have

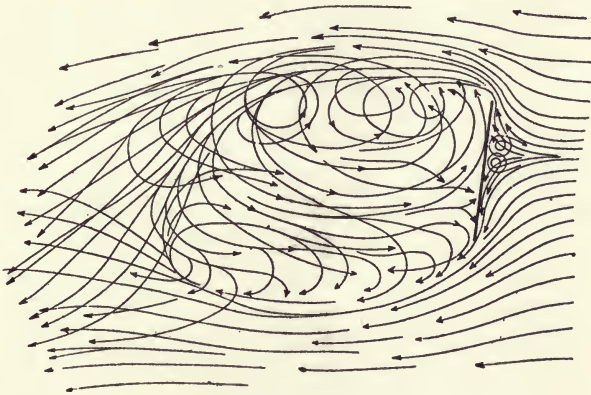

FIG. 48.

a diagram (fig. 48) of a stream of air meeting a plate at an angle of 80° , where the reflux action is shown *most distinctly*, the stream lines having been drawn from *actual observation*.

On the next page of this monumental work we find a *schema* of stream line flow past a plate in normal presentation (fig. 49). In reference to this, M. Eiffel says: “in the two regions comprised between the dotted lines the eddies are such that it is not possible to fix any mean direction.”¹

It will be clear that—for air, *certainly*, and for water, probably—there *is* reflux when a stream of fluid meets a

¹ “ Dans les deux régions comprises entre les traits pointillés, les remous sont tels qu’on ne peut fixer une direction moyenne.”

body at rest. As shown in fig. 49, the ordinary stream lines enclose the body of vibrating liquid, which thins out and disappears at the edges of the plate. The pressure on the plate is the *potential* pressure in the stream line transmitted *through* the eddies, and *periodically reinforced* by the extra pressure caused by reflux. We see, therefore, that there is no violation of the principle of the conservation of energy. At the edges, the stream filaments appear to "wipe-off" the eddying masses of water, which thus have some cyclic motion imparted to them.

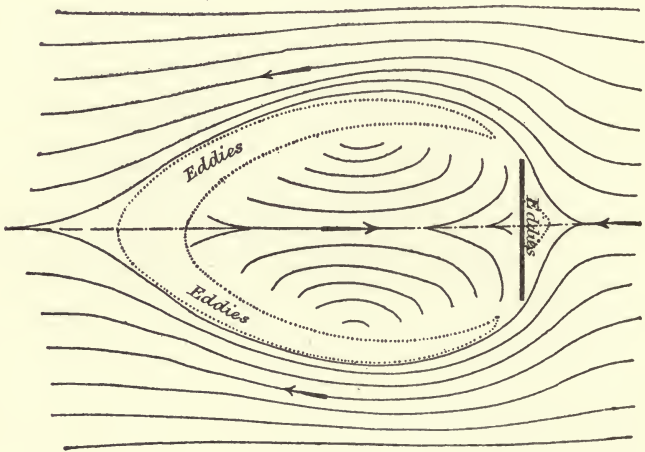

FIG. 49.

How are we to picture this action as taking place? If we imagine the plate or body to have a kind of "liquid prow" as it moves forward in liquid at rest, this prow divides the liquid, and the whole "plate-water system" moves forward at a uniform velocity. The liquid glides along the prow and never *strikes* the plate. When the body is at rest, however, the eddying liquid is not so easily deflected by the prow; so that some of it actually *does strike* the plate, and so causes impact *with reflux*. It will be seen thus, that not only does experiment show that pressure on the anterior surface of the plate is not the same in both

cases, but that there are good theoretical reasons *why it should not be so*.

There is a statement made by Dr. W. Froude, and apparently pertinent to this question, which has not, perhaps, received the attention it deserves, though it is referred to by Lord Rayleigh in one of his early papers. “As a proof that an edgeways motion of an elongated body through water is not without influence on the force necessary to move it with a given speed broadways, Mr. Froude says,¹ Thus, when a vessel was working to windward, immediately after she had tacked and before she had gathered headway, it was plainly visible, and it was known to every sailor, that her leeway was much more rapid than after she had begun to gather headway. The more rapid her headway became, the slower became the lee-drift, not merely relatively slower, but actually slower.

“Again, any one might obtain conclusive proof of the existence of this increase of pressure occasioned by the introduction of the edgeways component of motion, who would try the following simple experiment. Let him stand in a boat moving through the water, and taking an oar in his hand, let him dip the blade vertically into the water alongside the boat, presenting its face normally to the line of the boat’s motion, holding the plane steady in that position, and let him estimate the pressure of the water on the blade by the muscular effort required to overcome it. When he has consciously appreciated this, let him begin to sway the blade edgeways like a pendulum, and he will at once experience a very sensible increase of pressure; and if the edgeways sweep thus assigned to the blade is considerable and is performed rapidly, the greatness of the increase in the pressure will be astonishing until its true meaning has been realized. Utilizing this proposition, many boatmen, when rowing a heavy boat with narrow-bladed oars, were in the habit of alternately raising and lowering the hand with a reciprocating motion, so as to give an oscillatory dip to the blade during each stroke, and thus obtained an

¹ *Proceedings of the Society (sic) of Civil Engineers*, vol. xxxii, in a discussion on a paper by Sir F. Knowles on the Screw Propeller.

equally vigorous reaction from the water with a greatly reduced slip or sternward motion of the blade."

It is not exactly clear what Dr. Froude meant by the expression "the edgeways component of motion": it conveys no mental picture to me, and it appears to be only introducing an unnecessary complication into a subject which is, already, sufficiently difficult.

Lord Rayleigh, referring to this, says: "It is not difficult to see that in the case of obliquity we have to do with the whole velocity of the current, and not merely with the resolved part." This, also, does not appear to make matters any clearer.

Following the previous reasoning, we see that when the vessel has "headway" (*is moving steadily*) the liquid is a *static* one; whilst, when "tacking," it is not. The pressure—and therefore "leeway"—should then be greater than when the vessel is travelling at a *steady* velocity.

So, also, when the oar is kept steady, the liquid is a *static* one; whilst, when it is being made to oscillate, the motion of the liquid—*referred to the oar*—is *constantly changing its direction*. In fact, the result is just what we should expect, on a *priori* reasoning. It is rather a strong confirmation of Dubuat's Paradox.

SUMMARY

When a body is at rest and the liquid *flows* past it, the pressure at the centre is, not the "velocity head" h , but $1.5 h$. There are good *theoretical* reasons in favour of "Dubuat's Paradox" being correct; whilst all Dubuat's and Duchemin's experiments, when carefully examined, confirm it.

In all liquids, viscid or not, without a free surface (the bounding envelope being inextensible) all bodies are stream-line.

REFERENCES

E. J. MAREY, *Le Mouvement*.

DR. HELE-SHAW, "The Distribution of Pressure due to flow round Submerged Surfaces" (*Inst. Naval Architects*, 1900).

DR. W. FROUDE, *Proceedings of the Institution of Civil Engineers*, vol. xxxii.

CHAPTER XI

MOVEMENT OF LIQUIDS THROUGH APERTURES IN THE WALL OF A VESSEL—MOUTHPIECES

THE first author who investigated the problem of the flow of liquids out of a hole in a vessel was Newton. In the Prop. XXXVI, Book II of the *Principia*, he “defines the motion of water running out of a cylindrical vessel through a hole made

at the bottom.” The form of flow that he assumed being what is commonly known as a “cataract flow”: such flow as would occur from the liquid obeying the laws of heavy bodies.

If A C D B (fig. 50), be a cylindrical vessel, A B

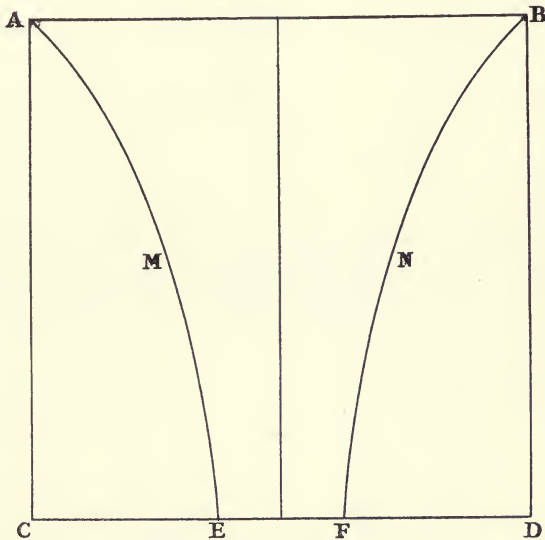

FIG. 50.

the mouth of it, C D the bottom parallel to the horizon, E F a circular hole in the middle of the bottom; then, in brief, Newton’s assumption is that the liquid layer A B, and the whole body of water A M E F N B will descend vertically

and pass through the hole EF without disturbing any of the rest of the water ; in other words, the flow will be such that the parts of the water $AMEC$ and $BNFD$ will remain *at rest*, the flow being entirely through the central part—in fact, as if the parts $AMEC$ and $BNFD$ were *frozen*.

Liquids, clearly, do not flow like this and Newton's proposition is more interesting than useful in explaining the motion of a liquid through an orifice.

The next author was Daniel Bernoulli, In his *l'Hydro-*

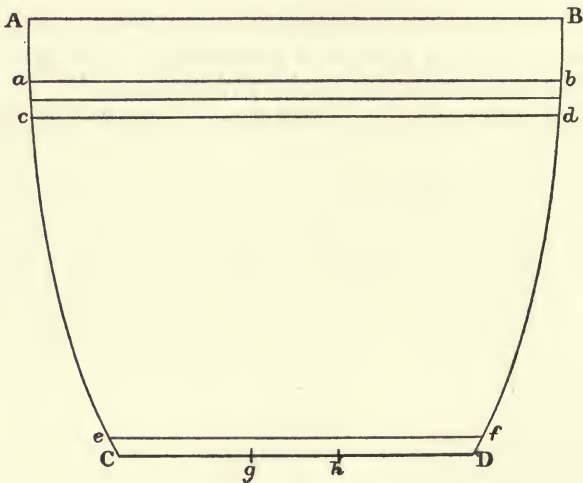

FIG. 51.

dynamique he proceeds to discuss the problem on the principle of the conservation of energy—called by him *vis viva*—and the assumption he made was as follows:—

He assumed $ACDB$ (fig. 51), to be a vessel with an aperture at the bottom gh , and filled with water up to the level ab . When the aperture gh was opened, he assumed the water to move in horizontal layers, so that the thin layer ab moved down to cd , the layer cd moving down to a level just below it, and so on down to the bottom of the vase ef . This, though nearly true for the layers at the top, leads to the assumption that the liquid in the

lowest layer *ef* must move from C and D to *gh* with an *infinite velocity*. It need hardly be said that the idea, though ingenious, very frequently leads to results which are not in accord with experiment.

Later on we have the Chevalier de Borda (*Académie des Sciences*, 1766), who made a somewhat different assumption.

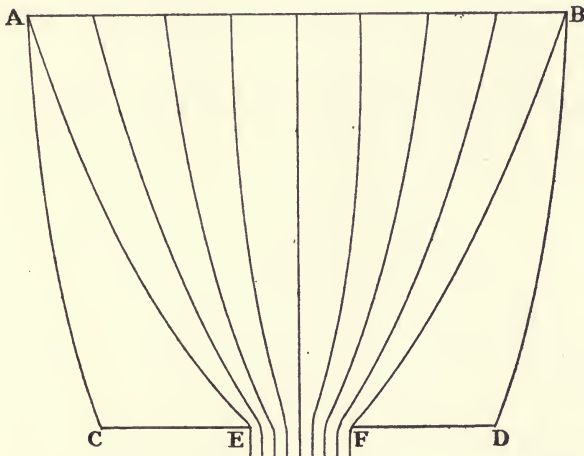

FIG. 52.

If A C D B (fig. 52) represents the vessel containing the liquid whose surface is A B. Dividing A B and E F into an equal number of parts, the water is supposed to flow, as shown by the stream-lines, to the opening E F at the bottom of the vessel.

This form of flow, like all the preceding, violates what may be considered one of the fundamental principles of Hydrodynamics; that is, that a liquid *must flow from any region of higher pressure to any region of lower pressure*. It is clear that in *all of them* there is supposed to be liquid *at rest* at the parts of the vessel near C and D; such liquid being at rest, must, necessarily, be under greater pressure than the liquid flowing out of the aperture. *Per contra*, if it is under greater pressure *it cannot be at rest*.

To get a clear idea of how a liquid gets from the inside to the outside of a vessel, it is necessary, first of all, to

recognize *thoroughly* that flow *must take place*, in any static liquid, between any two points in the same horizontal plane of the liquid, between which there is a *difference of pressure*, or potential. This is recognized by meteorologists, for the air; but it does not appear to be seen ordinarily that the same principle *applies to all static liquids*.

Having assumed this as beyond dispute, the following theory of the flow of a liquid through an aperture is put forward tentatively.

Let A B (fig. 53) represent the bottom of a large and deep tank, which has a circular aperture E F in the centre of it,

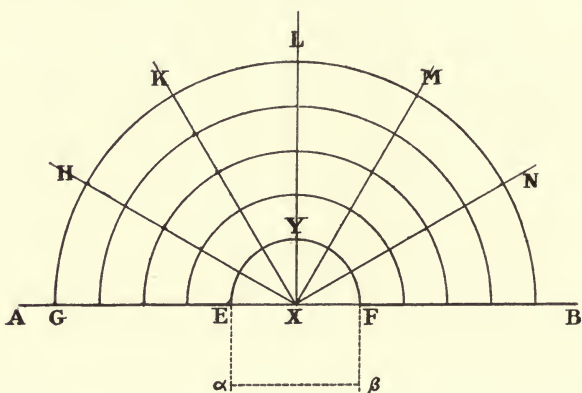

FIG. 53.

and which is temporarily closed. Let G, H, K, L, M and N be any number of points all situated on any imaginary hemisphere, whose centre is X—the centre of the hole E F.

Now, since we have assumed the tank to be deep, we may assume the pressure at all these points, as well as at E and F, to be *sensibly* the same: this assumption does not affect the argument, and the error can be corrected later.

Let us next imagine the aperture E F to be opened. What have we done by opening this aperture? We have created a region of *lower pressure* at E F, with the result that *all the molecules* of water at G, H, K, L, M and N will commence moving at an *equal velocity* towards the point

X. All the molecules in the thin hemispherical layer, moving at the same velocity towards the centre, will always remain on some hemispherical surface, whose diameter will gradually decrease. Let us now think of the pressures; when steady motion is established, the isobaric surfaces, or surfaces of equal pressure, at this part of the vessel, will also be hemispheres (like the different skins of an onion), and these will also decrease from G, H, K, L, M, N towards the point X. Following this train of thought, it is clear that eventually the liquid enclosed in the hemisphere E Y F will pass through E F into an imaginary tube E α β F. If we assume that there is no change of velocity inside and outside of E F (not correct, of course, but this will be allowed for later), then the liquid will flow into a cylinder E α β F whose height E α = X Y. It is evident that since the volume of the hemisphere is only *two-thirds* of that of the cylinder, the liquid in the former *cannot fill* the latter, and that there must be *some sort* of contraction. The sectional area of the *vena contracta* being two-thirds, or 0.66, of the area of E F. We see that *on the assumptions made* the area of the *vena contracta* should be 0.66 of the aperture. Newton, who first measured the size of this *vena contracta* found it to be $\frac{1}{\sqrt{2}} = .7$ nearly; Newton's aper-

ture was only $\frac{5}{8}$ of an inch in diameter, and the head was 20 inches, the hole having been made at the *side* of the vessel, but he does not state if it was *near the bottom* or not—he says: “not to the bottom but to the side of the vessel.” If it was *near* the bottom his coefficient of contraction would be larger than if away from it. He says, also, he took the measurement of the *vena contracta* “with great accuracy at the distance of about half an inch from the hole.” Since this was nearly one diameter from the hole, this would perhaps account for his coefficient being greater than has since been found by other authors.¹

The abbé Bossut found *by measurement* that the area of this *vena contracta* was *almost exactly* 0.66. Subsequently,

¹ Hachette says, however, that he found a coefficient of contraction for the *smallest holes* as great as 0.78.

from experiments made by the measurement of "discharges," he came to the conclusion that for the "coefficient of discharge" a more accurate relation was 5 : 8, or the area of the contracted vein should be 0.625 of the area of the aperture.

Later experimenters appear to have found this to be slightly too large, and that the coefficient of contraction, " C_c ," is on the average 0.64" (Unwin, *Hydromechanics*); whilst the "coefficient of discharge" for a "sharp-edged plane orifice, $C = 0.97 \times 0.64 = 0.62$ " (Unwin, *Hydromechanics*), where the coefficient of velocity, $C_v = 0.97$.¹

Let us now examine the two assumptions referred to previously. It was assumed, temporarily, that the pressure was *sensibly* the same at all points on the hemisphere G H K L M N. This is clearly incorrect, for the pressure at L *must* be less than that at any other part of the hemisphere, and consequently the velocity of the molecule starting from L will be *less* than that of any of the others. This will necessitate the isobaric surfaces, or *surfaces of equal pressure*, being changed from the surfaces of hemispheres to those of oblate spheroids—the figure G H K L M N must be changed from a hemisphere to that of a half orange. No alteration in the argument is necessary since the volume of a semi-spheroid is equal to two-thirds of that of the circumscribing cylinder of the same height : in other words, if $E\alpha = XY$, the volume of the spheroid $EYF =$ two-thirds of that of the cylinder $E\alpha\beta F$. It is clear, therefore, that this assumption did not affect the argument in any way.

The other assumption, that there was no change of velocity inside and outside of EF , must now be examined. This also is incorrect, since the velocity of the liquid is being further *accelerated* by gravity. If we allow for this, it is clear that $E\alpha$ will be *greater* than XY : the volume of the liquid in the semi-spheroid will therefore be flowing into a cylinder whose volume is *more than 50 per cent. greater* ; this will necessitate the coefficient of contraction being *less than* 0.66. How much less will it be ? It is difficult to say, since the *coefficient is not a constant*.

¹ Fanning gives it as 0.974.

A little reflection will show that the *amount of acceleration*—the relation between $E\alpha$ and XY —will depend on the length XY , which also varies as EF . We see, therefore, that the coefficient of contraction will be *smaller* for a *large* hole than it is for a *smaller one*. In other words, we may express this in algebraical shorthand as

$$C_c = \frac{0.66}{f(D)}$$

where D = diameter of the hole and $f(D)$ is some undetermined function of D , but varying directly as D .

Now, does experiment show that such is the case? The measurement of a *vena contracta* is exceedingly difficult, and I am not aware that any one has ever made experiments to see whether it is the same for all sizes of apertures, *as well as in all directions*. Hachette (*Annales de Chimie*, 1816), certainly found that the flow through *very small apertures* was *greater, proportionately*, than it was through larger holes—it is not uncommonly *supposed to be less*—and if the flow was greater, it is clear that the *contraction of the vein must have been less*. In their report on M. Hachette's paper, MM. Poisson, Ampère and Cauchy say: "All conditions being equal, the *contraction* of a vein which issues from an orifice in a thin wall *decreases with the dimensions of the orifice*."

"For diameters *greater* than 10 millimetres the contraction becomes almost constant and remains between the limits of 0.40 and 0.37."¹ As stated previously, Hachette found the coefficient of contraction for the *smallest holes* as high as 0.78.²

¹ "Toutes circonstances étant d'ailleurs égales, la contraction de la veine qui soit par un orifice en minces parois décroît avec les dimensions de l'orifice."

"Pour les diamètres au-dessus de 10 millimètres, la contraction devient presque constante, et reste comprise entre les hauteurs 0.40 et 0.37."

² It will be noted that Unwin uses the term "coefficient of contraction" to mean that the cross section of the liquid jet is reduced to .66 of the area of the aperture. MM. Poisson, Ampère, and Cauchy employed the word "contraction" to mean that the section of the jet is reduced by 37 or 40 per cent., i.e., to .63 or .60, of the size of the aperture,

It would appear that de Borda suspected that such a relation existed ; for when comparing Newton's coefficient of contraction with his own measurements, he says, " perhaps Newton made his experiments with *too small an orifice* ; this reason alone suffices for explaining the difference ; in fact, it is evident that the friction of the liquid against the edges of the orifice should decrease the quantity of the contraction, since it retards the parts which tend most to contract the vein ; but this friction was proportionately greater in Newton's experiment than in mine ; therefore, for that reason alone, I ought to have found a greater contraction." ¹

I am not aware that M. Hachette's paper was ever published, so I rely entirely on the report on it made by MM. Poisson, Ampère and Cauchy.

There is another way of looking at this question. Joseph T. Michelotti, in 1783, first, I believe, pointed out that when a liquid issues from an aperture in the side of a tank, the pressure not being uniform over the area of the aperture, there was a difference in the velocity of the different filaments at different heights. If we imagine the orifice to be square and to be divided into an infinite number of horizontal areas, the velocity of discharge should be greater through the lower areas than through the higher ones. There is, nevertheless, a *mean* velocity by which we can multiply the area of the orifice to find the total water discharged ; there is also some horizontal sheet of water which is issuing at exactly this mean velocity : the centre of the line through which this sheet discharges may be called the " centre of velocity."

Suppose, first, the level of the water in the tank to be kept constantly to the top of a square orifice, the side of

¹ " Peut être vient-elle de ce que M. Newton a fait son expérience sur un orifice trop petit ; cette seule raison suffit pour expliquer cette différence ; en effet il est évident que le frottement du liquide contre les bords de l'orifice doit diminuer la quantité de contraction, puisqu'elle retarde les parties qui tendent le plus à contracter la veine ; or ce frottement était à proportion plus grand dans l'expérience de M. Newton que dans la mienne ; donc par cela seul je devais trouver une contraction plus grande."

which is a , Q = discharge of water, p the parameter ($2g$), z the head of water above any selected sheet. The velocity of discharge of this particular sheet will clearly be \sqrt{pz} ; and the discharge of water in this sheet will consequently be $adz\sqrt{pz}$; the total discharge through the whole aperture can be got by integrating z between a and 0 .

$$\therefore Q = \int_0^a adz\sqrt{pz} = \frac{2}{3}a\sqrt{pa^3}$$

whence
$$Q = \frac{2}{3}a^2\sqrt{ap}$$

Now if we call A the "compensated head" (Michelotti's word)—the head which would cause the *mean velocity*—then the discharge may be expressed as $Q = a^2\sqrt{Ap}$.

$$\therefore a^2\sqrt{Ap} = \frac{2}{3}a^2\sqrt{ap}, \text{ or } \sqrt{A} = \frac{2}{3}\sqrt{a}$$

whence $A = \frac{4}{9}a$.

If we put $a = 1$, then A become $\frac{4}{9} = 0.444$, etc.

Now if we call X the distance between the centre of velocity and the centre of figure of the orifice, we have—still putting $a = 1$,—

$$X = \frac{1}{2} - \frac{4}{9} = \frac{1}{18} = 0.0555, \text{ etc.}$$

Let us next suppose the square orifice subjected to a constant head of water b , above the top of the orifice. Following the same line of argument; the velocity of discharge of the sheet which is situated at z , below the top of the orifice, will clearly be $\sqrt{(b+z)p}$; and the discharge of water through this sheet will be $adz\sqrt{(b+z)p}$

$$\text{whence } Q = \int_b^{b+a} adz\sqrt{(b+z)p}$$

$$= \frac{2}{3}ap^{\frac{1}{2}}\left\{\overline{b+a}^{\frac{3}{2}} - b^{\frac{3}{2}}\right\}.$$

Again, as before, A being the compensated head, which produces the mean velocity,

$$Q = a^2\sqrt{Ap} = \frac{2}{3}a\sqrt{p}\left\{\overline{b+a}^{\frac{3}{2}} - b^{\frac{3}{2}}\right\}$$

from which we get $A = \frac{4}{9}a^2\left\{\overline{b+a}^{\frac{3}{2}} - b^{\frac{3}{2}}\right\}^2$.

The head which corresponds to the centre of figure being

$$b + \frac{a}{2} = \frac{2b+a}{2},$$

$$X \text{ will be } = \frac{2b+a}{2} - \frac{4}{9}a^2\left\{\overline{b+a^{\frac{3}{2}}}-b^{\frac{3}{2}}\right\}^2.$$

X is given for different heights in Table XXIII.

TABLE XXIII

$b : a.$	A.	$b + \frac{a}{2}.$	X.
$b = a$	1.485842	1.5	0.014158
$b = 2a$	2.491610	2.5	0.008390
$b = 3a$	3.494036	3.5	0.005973
$b = 4a$	4.495355	4.5	0.004645
$b = 5a$	5.496219	5.5	0.003781
$b = 6a$	6.496770	6.5	0.003230
$b = 7a$	7.497236	7.5	0.002744
$b = 8a$	8.497630	8.5	0.002470
$b = 9a$	9.497846	9.5	0.002154
$b = 10a$	10.498072	10.5	0.001928
$b = 11a$	11.498131	11.5	0.001869
$b = 12a$	12.498361	12.5	0.001639
$b = 13a$	13.498431	13.5	0.001569
$b = 14a$	14.498546	14.5	0.001454
$b = 15a$	15.498643	15.5	0.001357
$b = 16a$	16.498704	16.5	0.001296
$b = 17a$	17.498791	17.5	0.001209
$b = 18a$	18.498840	18.5	0.001116
$b = 19a$	19.498937	19.5	0.001063
$b = 20a$	20.498958	20.5	0.001042

The table shows that the difference, X, between A and $b + \frac{a}{2}$, when $b = 20a$, is only about 0.001; whilst, if $b = a$, it is fourteen times greater; and when $b = 0$, as was pointed out previously, the difference between A and $b + \frac{a}{2}$ is 0.06.

If what was advanced previously is sound, the coefficient of contraction should *increase* with the *increase of head*. A reference to Fanning's Table (Unwin's *Hydromechanics*) shows that this is the case with some apertures, whilst the reverse is true for others. The results having, however, been derived from a collection of different experiments,



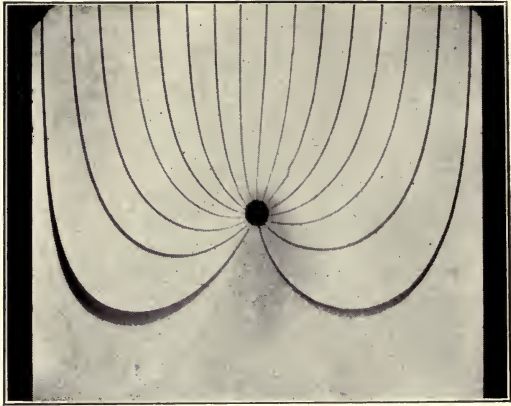

ACTUAL FLOW (A).

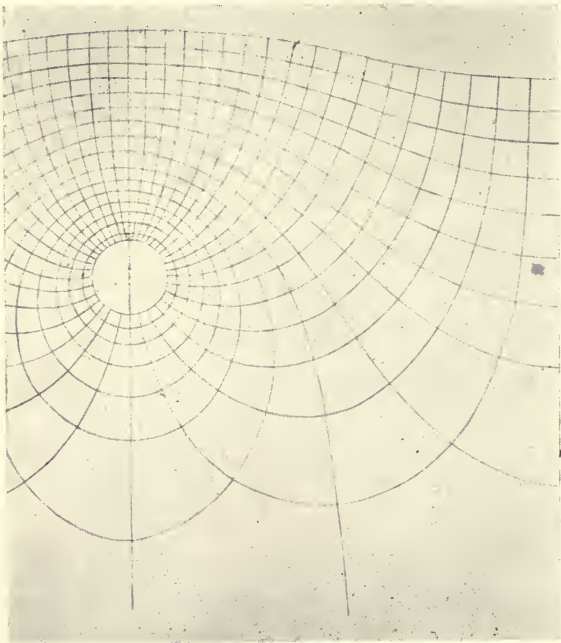

THEORETICAL FLOW (B).

FIG. 54.

carried out at different times and by different methods—and as they, further, appear to contradict one another occasionally—these tables can hardly be accepted as very strong evidence. More experiment is required.

To resume: a little reflection will show that all the “tubes of flow” of the liquid can only originate at the free surface of the liquid; a continual flow away from the boundary walls is impossible, since, if it occurred, the space near the walls would be left empty. It is clear that, *with the same depth of liquid above the aperture*, the shorter the *mean length of the tubes of flow*, the greater will be the supply of liquid to the aperture; and consequently the greater the coefficient of contraction and discharge. This will, perhaps, be better understood by reference to fig. 54 (A), which represents the flow of a liquid out of a small hole in a wall of a tank. This is not a fancy sketch, but from a photograph made by Dr. Hele-Shaw of the flow of glycerine. As in all the other photographs, it is a flow in *two dimensions only*.

It may be compared with fig. 54 (B), which is from a drawing of Dr. Hele-Shaw's of the theoretical flow of an inviscid liquid: the resemblance is very startling. If, therefore, the hole be at the bottom of the tank but *near one side*, the discharge should be greater than if it were *well away from the side*. Similarly, if the hole were near two sides of the tank—i.e., near a corner—the discharge and the coefficient of contraction should be *still* greater. In the limiting case, when the aperture is near *four* sides—that is, approximating to the size of the bottom of the tank—the discharge and the coefficient of contraction should be the greatest; and the latter should approach to 1.0. Experiment shows that this is so in all cases.

A similar line of reasoning would lead us to expect that, if the aperture be *inside* of the walls of the vessel—i.e., being the opening in a re-entrant tube—the discharge should be a *minimum*. This was first pointed out by de Borda: the re-entrant tube being commonly referred to as de Borda's “re-entrant ajutage.”

MINIMUM COEFFICIENT OF CONTRACTION—RE-ENTRANT
MOUTHPIECE OF DE BORDA

If a re-entrant tube was attached to the aperture, the coefficient of contraction and *ergo* the coefficient of discharge, was found by de Borda to decrease.

Unwin (*Hydromechanics*) referring to this, says: "In

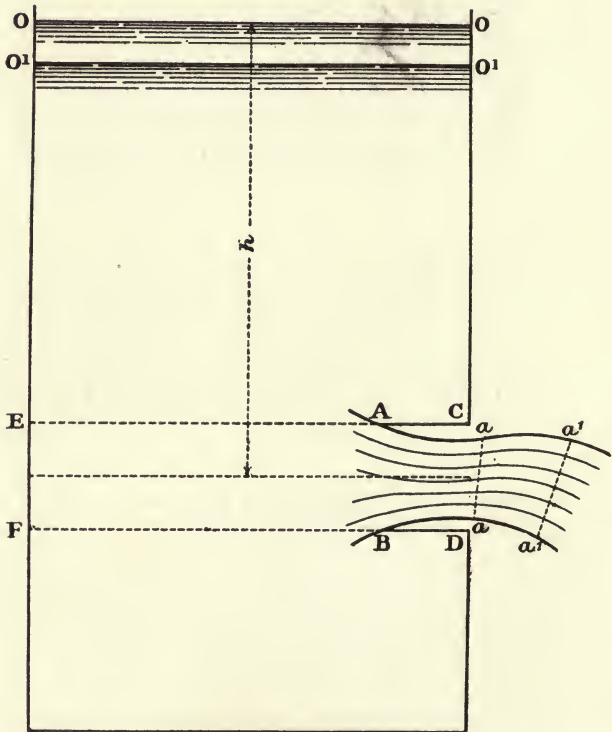

FIG. 55.

one special case the coefficient of contraction can be determined theoretically, and as it is the case where the convergence of the streams approaching the orifice takes place through the greatest possible angle, the coefficient thus determined is the minimum coefficient.

"Let fig. 55 represent a vessel with vertical [? flat] sides,

OO being the free water surface, at which the pressure is P_a . Suppose the liquid issues by a horizontal mouth-piece, which is re-entrant, and of the greatest length which permits the jet to spring clear from the inner end of the orifice, without adhering to its sides. With such an orifice the velocity near the points CD is negligible, and the pressure at those points may be taken equal to the hydrostatic pressure due to the depth from the free surface. Let Ω be the area of the mouth-piece, AB, ω that of the contracted jet aa . Suppose that in a short time t , the mass $OOaa$ comes to the position $O^1O^1a^1a^1$; the impulse of the horizontal external forces acting on the mass during that time is equal to the horizontal change of momentum.

“ The pressure on the side OC of the mass will be balanced by the pressure on the opposite side OE, and so far all the portions of the vertical surface of the mass, excepting the portion EF opposite the mouth-piece and the surface $AaaB$ of the jet. On EF the pressure is simply the hydrostatic pressure due to the depth, that is $(P_a + Gh)\Omega$. On the surface and section $AaaB$ of the jet, the horizontal resultant of the pressure is equal to the atmospheric pressure P_a acting on the vertical projection AB of the jet; that is, the resultant pressure is $-P_a\Omega$. Hence the resultant horizontal force for the whole mass $OOaa$ is $(P_a + Gh)\Omega - P_a\Omega = Gh\Omega$. Its impulse in the time t is $Gh\Omega t$. Since the motion is steady there is no change of momentum between O^1O^1 and aa . The change of horizontal momentum is, therefore, the difference of the horizontal momentum lost in the space OOO^1O^1 and gained in the space aaa^1a^1 . In the former space there is no horizontal momentum.

“ The volume of the space aaa^1a^1 is ωvt ; the mass of liquid in that space is $\frac{G}{g}\omega vt$; its momentum is $\frac{G}{g}\omega v^2 t$. Equating the momentum gained,

$$Gh\Omega t = \frac{G}{g}\omega v^2 t;$$

$$\frac{\omega}{\Omega} = \frac{gh}{v^2}.$$

$$\text{But } v^2 = 2gh, \text{ and } \frac{\omega}{\Omega} = C_c$$

$$\therefore \frac{\omega}{\Omega} = \frac{1}{2} = C_c.$$

a result confirmed by experiments with mouth-pieces of this kind."

This proof, which was first given by de Borda, is, of course, based on the assumption that the motion at C D is *negligible*, or approximates to *zero*. Since there is undoubtedly *some* motion at C D it will be well to see how far experiment confirms the fact that it is "negligible." De Borda measured the coefficient of discharge¹ and found

it to be $\frac{100}{194.5} = 0.5149$; "Bidone 0.5547; Weisbach 0.534"

(Unwin, *Hydromechanics*). All these values are *in excess* of 0.5, and if we divide these by the coefficient of velocity, which Unwin says is generally about 0.97, the difference is such as to indicate that the velocity at C D is certainly not "insensible"; that it can hardly be said that this velocity is "negligible."

If we compare Unwin's solution of the coefficient of contraction, with a re-entrant mouth-piece, with that given by de Borda, we find that the fundamental assumptions are rather different. Unwin supposes the horizontal mouth-piece to be "of the greatest length which permits the jet to spring clear from the inner end of the orifice"; whilst de Borda supposes the tube to be "infinitely small . . . and that the vein, after contraction, *remains in the state of contraction*, and flows on a horizontal and perfectly polished surface."

Unwin, clearly, made his assumption in order that the tube *should not be wetted*: de Borda by his assumption of a "perfectly polished surface" intends to postulate that the flow shall not be interfered with by the surface of the inside of the tube. If the liquid *wets* the tube, a secondary action takes place, which alters and increases the flow; as is very well known. De Borda's conditions can be arrived at

¹ The tube being at the *bottom* of the tank.

by the employment of a liquid which *does not wet* the tube, such for example as mercury flowing in glass. We find in the report of MM. Poisson, Ampère, and Cauchy, on Hachette's paper, previously referred to, that "perfectly pure mercury flows in a mouthpiece of iron, as it would do in an orifice in a thin wall; when, on the contrary, the mercury was dirtied by an alloy of tin, *which tinned the interior of the tube, the contraction of the vein disappeared.*"¹

The same authors also say: "In a mouthpiece *coated with perfectly dry wax*, water escaped as through a thin wall; but it filled the tube as soon as it had *wetted the wax*, for then the coating was, so to say, *replaced by the first layer of water* which was attached to it."

J. T. Fanning (*Hydraulic and Water Supply Engineering*), when referring to the increased discharge caused by adding a short tube to the hole in the thin wall, says that *if the tube be greased on the inside, increased discharge will not take place.*

I might quote de Borda himself on this question. In giving a description of another experiment, he says: "I lifted this weight [a cover to the vertical tube] perpendicularly, so that the fluid should contract regularly in entering the tube, and not touch the walls (for one must note that when it touched them, the attraction of the walls, and afterwards the exterior pressure of the atmosphere, deranged the contraction and even sometimes forced the liquid to issue in full bore)." ²

It is not by any means clear what de Borda meant by the "exterior pressure of the atmosphere" causing an increase of flow through the tube. This will be further discussed in the next chapter.

¹ "Le mercure parfaitement pur coule dans un ajutage de fer, comme il le ferait dans un orifice en mince paroi; quand au contraire le mercure est sali par un alliage d'étain qui étamait l'intérieur du tuyau, la contraction de la veine disparaissait."

² "Je levais ce poids perpendiculairement à fin que le liquide se contractât régulièrement en entrant le tube et n'en touchât point les parois (car il faut remarquer que lorsqu'il les touchait, l'attraction de ces parois, et ensuite la pression extérieure de l'atmosphère dérangent la contraction et forcent même quelque fois le fluide de sortir à plein tuyau)."

SUMMARY

When a liquid issues through a hole in a thin wall of a vessel, it contracts, and the discharge is less than might be expected. This contraction appears to vary as some function of the diameter of the hole, i.e., being relatively less through a smaller hole than through a larger.

A re-entering mouthpiece reduces the discharge to a *minimum*, which appears to be rather greater than 0.5.

REFERENCES

Sir ISAAC NEWTON, *Principia*.

DANIEL BERNOULLI, *l'Hydrodynamique*.

Le Chevalier DE BORDA, *Académie des Sciences*, 1766.

M. HACHETTE, *Annales de Chimie*, etc., 1816. (Report by MM. Poisson, Ampère et Cauchy.)

J. T. FANNING, *Hydraulics and Water Supply Engineering*.

JOSEPH THÉRÈSE MICHELOTTI, *Mémoires de l'Académie de Turin*.

CHAPTER XII

SUBJECT CONTINUED—EXTERNAL MOUTHPIECES—THE SEVILLE PUMP—BELLANGÉ PUMP

IN the last chapter the assumptions made by Unwin and de Borda, when calculating the co-efficient of contraction of a liquid issuing through a re-entering mouthpiece, were compared; and it was pointed out that, though they were *apparently* very different, they resembled one another in their object of eliminating the possibility of the tube being *wetted*, or, in other words, of the liquid *adhering* to the walls of the mouthpiece; since, for *some reason or another*, if the tube is wetted the *discharge is increased*.

It was observed that de Borda's explanation of this action was by no means clear. If, however, de Borda's explanation is not obvious, the same must be said for the modern one. Fanning, referring to it, says:—

“*Increase of coefficient.* There is an influence affecting the flow of water through short cylindrical tubes, sufficient to increase the coefficient materially, that does not appear when the flow is through a thin partition. The *contraction of the jet still occurs* as in the flow through a thin partition, but after the direction of the particles has become parallel in the *vena contracta*, a force acting from the axis of the jet outward, together with the reaction from the exterior air, begins to dilate the section of the jet and to fill the tube again. The tube is, in consequence, again filled at a distance, depending upon the ratio of the velocity to the diameter, of about two and a half diameters from the inner edge of the orifice. The axial particles of the jet not receiving so great a proportion

of this reaction from the edges of the orifice as the exterior particles, obtain a greater velocity, a portion of their force being transmitted to their surrounding films through divergent lines, and the velocity of the exterior particles within the tube is augmented, and the section of the jet is also augmented, until its circumference touches the tube." [Italics added to parts I wish to draw attention to.]

I am afraid that this paragraph conveys no impression of any kind to my mind. What the writer means is certainly not obvious. We see that de Borda's "exterior pressure of the air" is brought in; but what is meant by the "reaction from the exterior air?" The pressure of the air can surely only *retard* the discharge, and not *accelerate it*. What also is meant by the "force acting from the axis of the jet," which behaves in this very curious manner? We see that *the contraction of the jet still occurs*; and in another paragraph we are told that there is "a vacuum round the *vena contracta*." What causes this "negative pressure" to change to a positive pressure? In another paragraph we find that if the inside of the tube is greased the "vacuum does not appear."

I have only quoted this paragraph in order to show that if de Borda's explanation is not satisfying, this modern one is no improvement.

Unwin makes no reference to this at all; he states the facts and leaves the explanation severely alone.

The reader will have gathered from the foregoing, although I have not perhaps stated it definitely, that if an exterior mouthpiece, or "ajutage," as it is sometimes called, is fixed to a hole in a thin wall, the discharge is *increased, provided that the walls of the tube are wetted; but not otherwise*.

Referring to this exterior mouthpiece Unwin says (*Hydro-mechanics*): "Let fig. 56 represent a vessel discharging through a cylindrical mouthpiece at the depth h from the free surface, and let the axis of the jet XX be taken as the datum with reference to which the head is estimated. Let Ω be the area of the mouthpiece, ω the area of the stream at the contracted section E F. Let v p be the velocity and pressure at E F, and v_1 p_1 the same quantities at G H. If

the discharge is into the air p_1 is equal to the atmospheric pressure p_a .

“ The total head of any filament which goes to form the jet, taken at a point where its velocity is sensibly zero, is $h + \frac{p_a}{G}$; at E F the total head is $\frac{v^2}{2g} + \frac{p}{G}$; at G H it is $\frac{v_1^2}{2g} + \frac{p_1}{G}$.

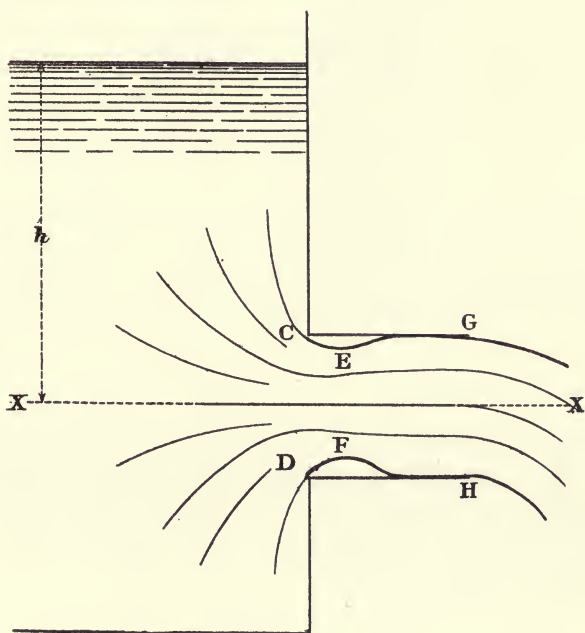

FIG. 56.

“ Between E F and G H there is a loss of head due to abrupt change of velocity, which may have the value

$$\frac{(v - v_1)^2}{2g}$$

“ Adding this head lost to the head at G H, before equating it to the heads at E F and at the point where the filaments start into motion,

$$h + \frac{p_a}{G} = \frac{v^2}{2g} + \frac{p}{G} = \frac{v_1^2}{2g} + \frac{p_1}{G} + \frac{(v - v_1)^2}{2g}$$

But $\omega v = \Omega v_1$, and $\omega = C_c \Omega$, if C_c is the coefficient of contraction within the mouthpiece.

$$\text{Hence } v = \frac{\Omega}{\omega} v_1 = \frac{v_1}{C_c}$$

“Supposing the discharge into the air, so that $p_1 = p_a$:

$$h + \frac{p_a}{G} = \frac{v_1^2}{2g} + \frac{p_a}{G} + \frac{v_1^2}{2g} \left(\frac{1}{C_c} - 1 \right)^2$$

$$\frac{v_1^2}{2g} \left\{ 1 + \left(\frac{1}{C_c} - 1 \right)^2 \right\} = h$$

$$\therefore v_1 = \frac{1}{\sqrt{1 + \left(\frac{1}{C_c} - 1 \right)^2}} \sqrt{2gh} \quad \dots (1),$$

where the first term on the right is evidently the coefficient of velocity for the cylindrical mouthpiece in terms of the coefficient of contraction at E F. Let $C_c = 0.64$, the value for simple orifices, then the coefficient of velocity is

$$C_v = \frac{1}{\sqrt{1 + \left(\frac{1}{C_c} - 1 \right)^2}} = 0.87 \quad \dots (2).$$

“The actual value of C_v found by experiment is 0.82, which does not differ more from the theoretical value than might be expected if the friction of the mouthpiece is allowed for. Hence, for mouthpieces of this kind, and for the section at G H,

$$C_v = 0.82, \quad C_c = 1.00, \quad c = 0.82,$$

$$\Omega = 0.82 \Omega \sqrt{2gh}.”$$

“It is easy to see from the equations that the pressure p at E F is less than the atmospheric pressure. Eliminating v_1 we get

$$\frac{p_a - p}{G} = \frac{3}{4} h \text{ nearly } \dots \dots \dots (3);$$

$$p = p_a - \frac{3}{4} Gh \text{ per square foot.}$$

“If a pipe connected with a reservoir on a lower level is introduced into the mouthpiece at the part where the contraction is formed (fig. 57) the water will rise in this pipe to a height

$$K L = \frac{p_a - p}{G} = \frac{1}{2}h \text{ nearly.}$$

“ If the distance X is less than this, the water from the lower reservoir will be forced continuously into the jet by the atmospheric pressure, and discharged with it. This is the crudest form of a kind of pump known as the jet pump.”

I have quoted this in full, because it is somewhat clearer

than de Borda's Problem IV, being in more modern notation. In neither of the Problems, however, has the *length* of the mouthpiece been taken into account,— and this is most important. It must be noted that the *contraction* at E F remains, — although the added mouthpiece *causes an increase of discharge*. Clearly, therefore, the velocity at E F

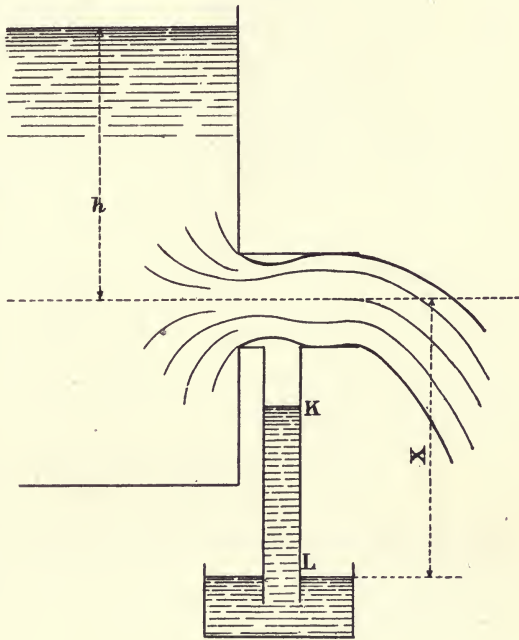

FIG. 57.

must be *very considerably* increased. If the velocity is increased it is clear that the *kinetic energy has been increased*, and that some of the *potential energy* must have been converted into *kinetic energy*, according to Bernoulli's law. As the only potential energy available for this is the atmospheric pressure, the *pressure* in the *vena contracta* must be now *less than the atmospheric*, as we see is the case in fig. 57. Also between E F and G H there is an “ abrupt change of velocity,” and

consequent *loss of energy* (not annihilation, of course), resulting in a loss of head, measured by $\frac{(v-v_1)^2}{2g}$. It is clear that the liquid must be here *changing shape* to account for this loss. As was pointed out by de Borda—and even Bernoulli before him—Bernoulli's theorem only holds if the change of velocity takes place by *insensible degrees*. If there is any abruptness in this change, then there is a loss of *vis viva*—energy—such as occurs when inelastic bodies strike one another. It may not be uninteresting to give de Borda's lemma on this latter point.

Let an inelastic body *a* (*corps dur*), having a velocity *u*, strike another inelastic body A, which has a velocity V, what is the loss of *vis viva* which will be caused by the shock?

SOLUTION

The sum of the *vis vivæ* before the shock was $= \frac{au^2 + AV^2}{2g}$,

after the shock this sum $= \frac{a+A}{2g} \left(\frac{au + AV}{a+A} \right)^2$; subtracting the latter from the former, it will be found that the loss of *vis viva*—energy—

$$= \frac{aA}{a+A} \frac{(u-V)^2}{2g}. \quad \text{C. Q. F. T.}$$

De Borda, in his Problem IV employs $m = \frac{1}{C_c}$ instead of the coefficient of contraction; hence his formula, corresponding to Unwin's (1), becomes

$$v_1 = \frac{1}{\sqrt{m^2 - 2m + 2}} \sqrt{2gh}, \text{ and}$$

Unwin's coefficient of velocity becomes

$$C_v = \frac{1}{\sqrt{m^2 - 2m + 2}}.$$

I think this, is perhaps, a more convenient form than that given by Unwin. Some examples of the use of this formula will be given presently, when the reader will see how important it is to the comprehension of the flow of water into, as well as out of, vessels.

To return to the question of the influence of the length of the tube on the discharge, F. D. Michelotti (*sperimenti idraulici*) gives the discharge for tubes of different lengths, which will be found in Table XXIV. It will be seen that the discharge *increases* steadily up to a length of about two and a half diameters, after which it decreases slowly. It is *not a constant*, as one might imagine from reading de Borda's and Unwin's writings on the subject.

TABLE XXIV.

Relation $\frac{l}{d}$ length of tube to its diameter.	Relation m effective discharge to (?) theoretical discharge.
0	0.6096
$\frac{1}{2}$	0.6169
1	0.7671
2	0.8157
$2\frac{1}{2}$	0.8221
3	0.8201
4	0.8179
5	0.8095
6	0.8070
7	0.8032
8	0.7997

Venturi showed, further, that if a small hole is opened in the tube *opposite the position of the vena contracta* "the increase of expenditure *diminishes or entirely ceases*, and the fluid is *no longer continuous in the tube*" (Prop. IV, Exp. 12).

I might here point out that de Borda showed that if the orifice of the *re-entrant* mouthpiece was *surrounded by a circular plate* the discharge was *increased through the tube*, so that the flow was the same as if through a thin wall, i.e., from about 0.5 to 0.62 or thereabouts. This might have been suspected if one thinks of the different conditions introduced.

De Borda carried out another very interesting experiment, first suggested by Bernoulli. He made a tube of tin 1.5 inches in diameter, and 1 foot in length (fig. 58), the tin

being well polished and the edges of the tube very sharp. This tube was immersed vertically in a large vessel of water, the upper orifice having been closed, so that the contained air prevented the water from rising in the tube. When the upper orifice was *suddenly* opened, he observed the height to which the water rose in the tube above the level of the water in the vessel. After many experiments he found that if the tube was depressed in the liquid 8 inches 0.5 line, the water rose exactly to the top of the tube, i.e., 4 inches less

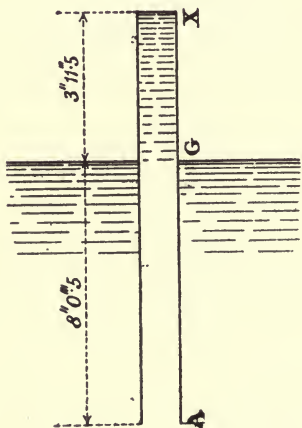

FIG. 58.

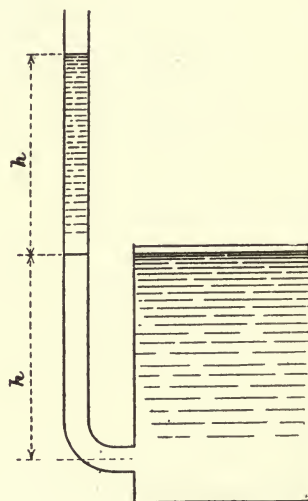

FIG. 59.

half a line. De Borda says that Bernoulli, who treated the question theoretically and mathematically, had found that the liquid *should* rise to a height of 8 inches; he had, however, made no allowance for the reduction of discharge caused by the re-entrant mouthpiece.¹ It is only fair, however, to point out that Bernoulli cites other experiments

¹ Bernoulli's argument being the same as that to be found in textbooks, which is as follows:—

“Let a vertical tube be connected with an orifice as shown in fig. 59. In the first place, let the tube be empty, and let the orifice be closed. On opening the orifice the liquid commences to rise in the tube, and will continue to rise until the gravitational energy of

which are not in agreement with those of de Borda ; but the tubes employed were too small for the results to be convincing.

This experiment was again modified by de Borda, who placed a flat circular disc, 12 inches in diameter, round the lower orifice of the tube. He then found that if the tube was submerged 7 inches 1 line, and, as before, the upper orifice was suddenly opened, the liquid rose to the level of the top of the tube. We have here the relation of 85 lines : 59 lines, which gives a " coefficient of head " (if I may coin a word) = 0.694, as against rather less than 0.5, in the other experiment.

Since, however, de Borda says the water rose in the tube about 2.5 lines *before the upper orifice was opened*, the depression of the liquid was thus only about 82.5 lines instead of 85 ; so that the real coefficient would be greater than 0.694, viz. $\frac{59}{82.5} = 0.715$. Making the same allowance in the other

case the coefficient would be $\frac{47.5}{94} = 0.5$, *almost exactly*.

The reader will notice here the great difference between the velocity of discharge when the aperture is opened *sud-*

the liquid within the tube is just equal to the work done on that liquid before it issues from the orifice ; when this condition has been attained, the liquid in the tube will be stationary for an instant. Let a be the sectional area of the tube, and H the height to which the liquid rises in it ; then the gravitational energy of the liquid within the tube is equal to $\rho a H \times \frac{gH}{2}$, since the centre of gravity of the liquid in the tube is at a height $\frac{H}{2}$ above the orifice. The work done on the mass $\rho a H$ before it issued from the orifice is equal to $\rho a H \times gh$, and thus

$$\frac{g\rho a H^2}{2} = g\rho a H h \therefore H = 2 h$$

and the liquid rises in the tube to a height h above the free surface of the liquid in the tank (fig. 59). The liquid then flows back into the tank until the tube is emptied ; and *in the absence of viscosity* the tube would be alternately filled to the height H , and then completely emptied at regular intervals." (Edser, *General Physics for Students*).

denly, and that when the velocity has become *steady*. In the former case the "head" is $2h$, changing to *zero*, and becoming $2h$ again. This oscillation is *very rapidly* damped, when the constant head becomes h . It is a matter of the commonest observation that if you are watering a garden with a hose you can cause the water to go *higher* and *further* if you open and close the cock *suddenly*, than it will when the cock is *left open* and the velocity of the discharge becomes steady.

If we now examine this question by de Borda's formula, in Prop. IV,

$$GX = \frac{AG}{m^2 - 2m + 2}$$

where $\frac{1}{m}$ = coefficient of contraction.

Or by Unwin's formula (1)

$$GX = \frac{AG}{1 + \left(\frac{1}{C_c} - 1\right)^2}$$

when C_c is the coefficient of contraction.

If $m=2$, or $C_c = \frac{1}{2}$ (as found theoretically for a re-entrant mouthpiece), then

$$GX = \frac{AG}{4 - 4 + 2} = \frac{AG}{2}$$

De Borda found, however, that the coefficient of contraction for a re-entrant mouthpiece was 0.515, whence $m = 1.9425$. Putting this value in the equation, GX becomes almost exactly equal to $\frac{AG}{2}$.

When the plate was put round the orifice of the tube, the contraction and discharge was as through a thin partition. In this case, de Borda found the coefficient of contraction $= \frac{1}{6}$. Whence $m = \frac{6}{5}$. Putting this value into the equation $GX = \frac{AG \times 100}{136}$, which, by putting $AG = 82.5$ lines, as before, gives $GX = 60\frac{2}{3}$ lines, where experiment gave $GX = 59$ lines only. This may easily be accounted for by the resistance due to viscosity, which is small but appreciable.

The whole of this subject of the passage of a liquid through a thin wall—even a partition *in the inside of a vessel*—is very interesting, and most useful to engineers who wish to calculate the time required for emptying or filling any vessel from the bottom.

The student who wishes to study the mathematics of the subject further is referred to de Borda's very interesting paper in the *Académie des Sciences*.

It may be well to consider the question of the passage of a liquid upwards through a thin wall. Unwin says (*Hydromechanics*) that the liquid "rises nearly to the level of the free surface of the liquid in the vessel from which it flows"; *but*, he adds later, that the orifice *must have a suitable form*. In his diagram he gives a very suitable *concave form*: if the surface were *convex* the same good result would not be obtained; still less if there had been a cylindrical mouthpiece fixed to the aperture; worse still if the mouthpiece had projected a little inwards.

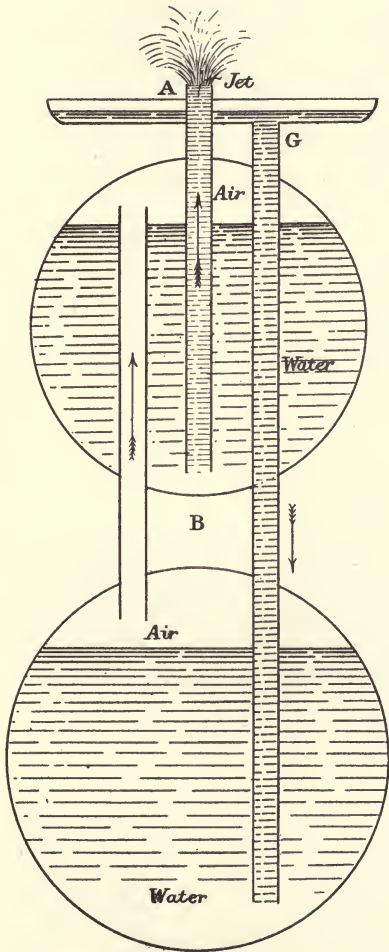

FIG. 60.

We have seen in the experiments of de Borda referred to, that the liquid did not rise in the tube as high as Bernoulli had calculated, theoretically, that it *should* do. To explain, further, what I mean, I will

refer to the well known Hero's fountain (fig. 60), not uncommonly used as a scent fountain ; the discharge, being through a re-entrant tube, A B, will not attain the height of the difference of level between the two water surfaces. If a flat collar were placed round the mouth of the tube at B, the flow would be increased ; and, *a fortiori*, if the opening at B were made funnel-shaped, or if the opening at A were contracted, the water would rise more nearly to the " theoretical height." In this problem allowance has to be made for the coefficient of contraction ; but this is not usually done.

When there is a narrow jet at A, and this jet is removed, it is very commonly said that " the pressure has been taken off." This is not strictly correct, for the *pressure* is the same as before ; the *volume of water* passing in at B is not sufficient, and there is a loss of energy caused by the contraction.

THE SEVILLE PUMP

As will be found stated in every elementary textbook, a column of water of about 34 feet will balance the atmospheric pressure, so that, in an ordinary " lift pump," the suction pipe must be of less length than about 30 feet. So well is this known, that if almost any professor or engineer were asked how to make a pump which would lift water 55 to 60 feet, he would probably think the inquirer was an ignoramus. At the same time, this same professor, or engineer, would be perfectly well aware that there are many trees that lift their sap *well over this height*, not to mention the *Sequoia*, the height of which is colossal. How this is done, the inquirer would be told, is " one of the unsolved problems of nature." ¹ One way of solving the problem was discovered about 150 years ago in Seville, and the pump

¹ Francis Darwin said (1906) that the upward flow of sap in plants was still unexplained, as the fluid is, in fact, lifted in tall trees to a greater height than is compatible with the pumping action caused by the creation of a vacuum ; and all efforts to trace a succession of pumping stages have failed.

is called the "Seville Pump." As the origin of this pump is very little known, it may not be uninteresting to repeat the story; though the pump can hardly be recommended as very *economical*.

Some 150 years ago a Seville tinsmith entered into a contract to make a pump to supply a terrace, about 55 feet high, with water for some flowers. Apparently the tinsmith only knew of one kind of pump, which he duly made, and, needless to say, it would not work, since the water would not rise to the height of 55 feet in the suction tube. Very exasperated, the smith threw his hammer at this tin pipe, and struck it so violently, at a height of about 10 feet from the ground, that he made a hole in it of about $\frac{1}{2}$ inch in diameter. His rage did more than his genius, for immediately the water rose to the 55 foot level and came out of the pump. The experiment was repeated in Spain several times, and always with the same result.

When the report reached Paris, the Abbé Nollet wrote to M. Cat asking him, "since when had the laws of nature changed?" M. Cat's reply was, "La nature n'a pas changé ses lois, mais elle nous en cache encore quelques-unes, et elle a mis des conditions à celles qu'elle nous a laissé voir."

The explanation is, of course, very simple. The water was standing in the pipe—the diameter of which was rather less than 1 inch—at a height of rather under 30 feet. When the hole was made in the tube, air entered, cutting the water column in two. The lower 10 feet of water descended, whilst the upper 20 feet was forced up, by the pressure of the air, to the top of the tube. It appears hardly necessary to add that, since only the 20 feet of water was raised, it was necessary, before another supply could be procured, to close the hole and recommence pumping.

M. Cat made an improvement in this pump by putting a small tap where the hole in the tube was; this worked very well, if not exactly *economically*.

Later, M. Bellangé, a goldsmith of Paris, made a modification, by which a *constant* supply of water could be pumped. The principle was slightly different. His suction tube was 10 lines in diameter and about 55 feet in length. At about

1 foot above the level of the water he made a small hole in the pipe of about half a line ($\frac{1}{24}$ inch) in diameter. When the pump was worked, air rushed into the tube rhythmically, so that in the "rising main" there were alternate layers of water and air *all the way up the tube*. The air occupying more space than the water, the pump was only *actually lifting* a column of *considerably less* than 30 feet of water. This pump also worked well, though the "efficiency" was not such as would satisfy a modern engineer.

M. l'abbé Nollet, in his report on these pumps (*Académie des Sciences*, 1766) showed, by means of a lecture table experiment, how the Seville pump worked. He got a barometer tube of about four feet in length, one end of which was sealed up. At about 9 or 10 inches from the other end he had a hole drilled, of sufficient size to admit a large pin, this hole being stopped with wax. The tube having been filled with mercury, and inverted in a vessel of the same liquid, the level of the mercury in the tube came down to about $27\frac{1}{2}$ inches (Paris measure) from the lower surface. The liquid being at rest, the wax was removed from the small hole, when the lower 9 or 10 inches of mercury fell, whilst the upper portion ascended and struck the top of the barometer tube with great violence. So great was the velocity that the Abbé says the experiment had to be carried out carefully for fear of breaking the top of the tube by the shock. I wish specially to draw attention to this, as a very little reflection will show that the mercury could have been raised *many times four feet*.

In the Bellangé pump, it must not be imagined that *any sized* hole, placed *anywhere*, will give a satisfactory result. The exact size of the hole and the exact position were found, after many trials, as giving the best results.

Now, without pretending to say that this *is* the way tall trees get the sap up to their leaves, there can be, I think, no doubt that this is *a way they might* get it.¹

¹ Sir Oliver Lodge in his Presidential address to the British Association at Birmingham, 1913, said: "To attribute the rise of sap to vital force would be absurd; it would be giving up the problem and stating nothing at all. The way in which Osmosis acts to

The action taking place in a mouthpiece will be resumed again when I treat of, what I call, "negative resistance."

SUMMARY

A tube attached to the outside of a hole in a thin wall of a tank *increases* the discharge through this hole, *provided that the tube is properly wetted*. This discharge increases with the length of the tube *up to a certain maximum*; when the length of the tube *exceeds this maximum*, the discharge *decreases* again slowly.

Any sudden change of velocity in a liquid causes an *apparent* loss of energy, i.e., some of the energy is *converted into heat*.

It is not true, as is commonly taught in some books, that liquid issuing vertically from an orifice will *necessarily* rise *to the level of the source*: the *defect*, which is found experimentally, being *attributed to viscosity*. The height depends *primarily* on the *contraction of the vein caused by the orifice*. Viscosity has very little to do with the defect, the *shape* of the orifice being *all important*. With the *same liquid*, and therefore the *same viscosity*, different forms of orifice can be caused to *increase* or *decrease* this height.

REFERENCES

FRANCESCO DOMENICO MICHELOTTI, *Sperimenti idraulici*.

M. l'abbé NOLLET, *Académie des Sciences*.

LE CITOYEN J. B. VENTURI, *Recherches Expérimentales*, etc.

produce this remarkable and surprising effect is discoverable, and has been discovered."

Not knowing what experiments Sir Oliver based this statement on, *I wonder if he was extrapolating!*

CHAPTER XIII

RIVERS AND CANALS—A BODY FLOATING IN A STREAM MOVES FASTER THAN THE STREAM—CORRAISON OF STREAMS

A RIVER, or canal, may be defined as a stream *partially bounded* by a free surface.

The simplest form of canal we can imagine is one which is perfectly straight, *very broad*, in order to eliminate boundary effects at the sides, and properly designed, so that the slope of the surface of the water is *strictly parallel* to the slope of the bed of the canal. Now, it is clear that the slope of the surface is the *only* effective cause which can generate motion in the water; since, without this slope, the liquid would not be in movement.

If this water met with no resistance, its motion would be *accelerated indefinitely*, according to the law of bodies sliding down an inclined plane. We know that the velocity of flow is uniform; so the accelerating forces must be equal and opposite to the retarding forces, since they are balancing one another.

The accelerating force on a prism of the liquid may be expressed as $\omega b \Delta g \sin \varphi$, where ω is the area of the cross section of the prism taken perpendicularly to the slope of the surface, b an arbitrary length of the water parallel to the sides of the canal measured along the surface, Δ the density, or mass of the liquid per unit volume, g = gravity constant, and φ = the angle of slope of the surface with the horizontal.

As regards the retarding forces or resistance encountered by the liquid in the canal, Coulomb first, I believe, showed experimentally, that liquid resistance can be expressed by the simple formula

$$R = AV + BV^2$$

where R = resistance, and V is the velocity of the stream, A and B being constants. M. de Prony correlated these formulæ as,

$$\sin \varphi = \frac{\Omega}{\omega} \left(0.000024u + 0.003585 \frac{u^2}{g} \right)$$

where Ω is the "wetted perimeter" and u = mean velocity of the stream. This formula has been frequently verified, and has been found to give correct results.¹

We may accept this as an empirical formula, if we please, without committing ourselves to any theory, for the present. All I wish to insist upon is that the resistance must consist of *two terms*, one involving the *simple* velocity whilst the other involves the *square* of the velocity; and that Coulomb, by means of a well-known experiment which I have described elsewhere, showed that the term involving the first power of the velocity was entirely due to the viscosity of the liquid.

In the first chapter, referring to the *Principia*, it was pointed out that all resistance in incompressible liquids could be divided into—

- (1) Resistance due to the *density* of the liquid.
- (2) That due to "attrition," or the rubbing of the liquid against the solid.
- (3) That due to the viscosity, or "treachiness," of the liquid.

We know that the term $A V$ is solely due to the viscosity of the liquid; *therefore* the term $B V^2$ can only be due to the density of the liquid *and* to the "attrition."

The resistance due to "attrition" may be described as a "solid-liquid friction" (I am sorry I cannot call it "liquid friction," but that term has been already appropriated for another kind of resistance); such a resistance would, clearly, vary *as the pressure*, and would not be affected by the velocity, in other words, *it would be a constant*. If a river were composed of mercury flowing in a glass bed, this item would have to be taken into account. We know,

¹ These *coefficients*, based on experiments made on *very small* canals have since been shown to be incorrect for larger ones; no great importance should therefore be attached to them.

however, that there is no *rubbing* between a river and its bed; so that in the case of water there is no "attrition," or resistance caused by it (there have been authors, however, who thought liquid resistance might be expressed as, $R=C+BV^2$, where C is a constant).

It is clear, therefore, that the resistance varying as the *square* of the velocity is due to the inertia of the liquid. This is in accord with the mature view of Sir George Stokes, who said:—"Except in the case of capillary tubes, or, in case the tube be somewhat wider, of excessively slow motions, *the main part of the resistance depends upon the formation of eddies. This much appears clear; but the precise way in which the eddies act is less evident*" [Italics added].

Dubuat, Duchemin, and many others, even down to modern times, believed that the resistance in rivers was caused by the viscosity and the rubbing (*frottement*) on the bed. Even at the present day it is commonly taught that the resistance is caused by "fluid friction" of the river against the solid boundary.

"According to this common theory the water ought to flow with uniformly accelerated velocity;

For even the supposition of a certain friction would be of no avail, for such friction could not be transmitted through the mass."

(Stokes, *Math. and Ph. Papers*. Emphasis added.)

I might point out some of the difficulties in the way of believing the "fluid friction" theory—such, for example, as *increase* of wetted surface resulting in *less resistance*: or the difficulty of imagining how a resistance *caused by rubbing* could *increase as the square of the velocity*—but if such resistance "cannot be transmitted through the mass," it would be only waste of time to discuss the question. Stokes gave the explanation of the above-quoted statement, in an earlier paper, in the following manner: "When a ball pendulum oscillates in an indefinitely extended fluid, the common theory *gives the arc of oscillation constant*. Observation, however, shows that it diminishes *very rapidly* in the case of a liquid, and diminishes, but less rapidly, in the case of an elastic fluid. *It has been attempted to explain this diminu-*

tion by supposing a friction to act on the ball, and this hypothesis may be *approximately true*, but the *imperfection of the theory* is shown from the circumstances that *no account is taken of the equal and opposite friction of the ball on the liquid*" (*Math. and Ph. Papers*. Italics added). The whole mechanics of this subject appear to be in a very nebulous state.

Before discussing, in detail, the flow of a river, I may refer to a point which is, perhaps, more curious than important ; but which, when carefully considered, will throw much light on the theory of resistance here advanced. It was, as far as I am aware, first pointed out by Dubuat, though he says it had been long known to boatmen accustomed to navigating rivers, that a body floating freely on the surface of a stream of uniform velocity, should acquire, and does, in fact, acquire, a uniform velocity *greater* than that of the *central filament of the stream*. This fact, which reflection will show to be almost self-evident, has been denied by many people, and so is worth referring to at greater length.

Bazin (*Recherches Hydrauliques*) was acquainted with this fact, for he says : " It has been long known to the boatmen of the Rhine and to our *pontoniers* that a loaded boat, having a heavy draught of water, descends more quickly than the water which supports it, or the bodies floating on the surface." He, however, uses this as an argument that the *maximum* velocity of a stream is *below the surface*; which is *sometimes true* and *sometimes not*.

When any kind of body floats on a stream, having a slope which may be expressed as $\frac{1}{b}$, the body is situated on an inclined plane, and consequently is subjected to an accelerating force equal to the product of the weight of the volume of water displaced by the fraction $\frac{1}{b}$. This force tends to make it descend the slope, and would accelerate the velocity of its descent indefinitely, if the body were experiencing no resistance. Therefore, if we suppose the body, initially, to be only moving with the velocity of the liquid surrounding and supporting it, it will be *at rest, relatively*

to this fluid, and so will be meeting with no resistance from it. Therefore the accelerating force will continue to act and will impress *more* velocity on it ; until the excess of its velocity *over that of the fluid* causes such a resistance as will neutralize the accelerating force : when this occurs the motion will be steady, the accelerating force being *balanced by the resistance*.

The greater the volume of water displaced by the body, the greater will be the accelerating force ; and the greater also will be the *excess* of velocity of the body over that of the stream. Conversely, the *less* the volume of water displaced, the *less* will be this *excess* of velocity ; and, finally, when this volume of water is equal to the size of a molecule, all excess of velocity will disappear.¹

It may be asked, why should the body be *more* accelerated than would be the volume of water it displaces ? The accelerating action is, of course, the same in both cases ; and if this liquid were enclosed in a weightless envelope—or one whose density was the same as the water—this “ body of water ” would *flow faster than the rest*. Since *no change of form could occur* in this box of water—any more than it could in the floating body, which might even be a mass of ice—it is clear that, *one form of resistance* being removed, the body is *less retarded* than is the liquid surrounding and supporting it.

If one looks at a barge going down with the stream one will invariably see that the bargeman is *steering*—a thing he could not possibly do if the barge had no “ way ” on.

A corollary which follows from the foregoing is that a body floating freely in a stream will always place itself in the *middle of the stream*, and will follow the line of the central filament. This it will do because it will there meet with the least resistance in gaining the greatest uniform

¹ It is clear that, *generally*, the viscous resistance to motion of *similar* bodies floating in a stream is proportional to the *square* of their linear dimensions ; and the resistance to *change of shape*, *eliminated by replacing the water by the floating bodies*, is proportional to the *cube* of their linear dimensions ; hence the limiting velocity excess is *greater for large than for small* floating bodies of *similar shape*.

velocity which it is capable of acquiring ; the greater the amount of liquid displaced, the greater will be the tendency to retain this position, and to drive away, out of its course, any bodies smaller than itself.

Another corollary which follows from this is, that *the better the shape of the body immersed*—i.e., the less the resistance it offers to motion—the greater will be its *excess* of velocity over that of the stream.

Still another corollary : if a stream is charged with a number of floating bodies, its velocity must be *increased*, and *become greater* than if these bodies were replaced by equal parts of homogeneous fluid. Hence, rivers carrying ice after a thaw, or which are covered with floating logs of timber, must have a *greater velocity* than during their natural, uncharged condition.

It may be stated here, definitely, that *the chief resistance to the flow of a stream is caused by the fluid changing shape* : viscosity, undoubtedly, *assists*, but is only responsible for a part of the resistance.

This statement may appear very dogmatic, but I think sufficient evidence can be produced in support of it ; whilst I am unaware of any evidence that can be brought against it.

A further corollary to all this is that if a river were composed of a *frictionless liquid*—a liquid so “improved” that the viscosity was a *vanishing quantity*—it would flow exactly like water, eddies and all, only *faster*.

Now, how does a river flow ? Let us first imagine the slope of the surface—and of the bed, parallel to it—to be *exceedingly small* ; and the breadth *indefinite*, so as to eliminate any boundary effects at the sides. The top layer of molecules will slide over the next layer, and so on down to the bottom.

By assuming the slope of the surface to be *very small* we can consider all the resistance to change of shape to be “viscous resistance”—*resistance due to viscosity*, and which varies *as the velocity*, only.

Following Unwin’s line of reasoning (“Hydromechanics,” *Encyclopaedia Brit.*) let fig. 61 represent a vertical longi-

tudinal section of a portion of the stream, and let OA and O^1A^1 be the intersections with this of two transverse sections at a distance apart l . Let ab, cd be the traces of two planes parallel to the free surface, or the bed, and let us consider the equilibrium of the layer $abcd$ of width unity. Let $Oa = y$, $ac = dy$, and let v be the velocity of the particles comprised in $abcd$, v being the function of y which is to be determined. Taking the components of the forces acting upon $abcd$, parallel to OO^1 , the pressures on ac, bd , being

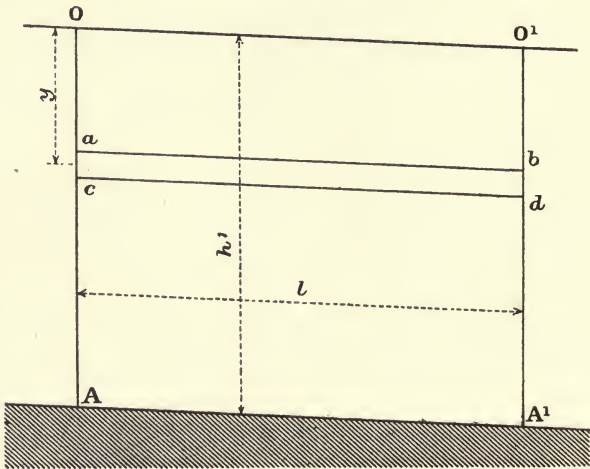

FIG. 61.

proportional to the depth from the surface are equal and opposite: also any viscous resistances on the *lateral* faces of the prism are *zero*, since in a *wide* stream there is no *relative sliding* between $abcd$ and the layers on each side. There remain only the resistances on the *upper and lower* surfaces, and the component of the weight.

If G = weight of a unit mass of the fluid, the weight of the layer is $Gldy$; and if i is the slope of the stream, the component of the weight, parallel to OO^1 , is $Gldy \sin i$. The viscous resistance on the face ab is *proportional to its area*, and to the difference dv of velocity between that of the face ab and that of a parallel face *immediately above it* and

inversely proportional to dy , the distance between these two faces. The resistance is therefore $-Kl \frac{dv}{dy}$ (where K is a constant), the negative sign being employed because, if v increases with y , $\frac{dv}{dy}$ is positive, while the action of the

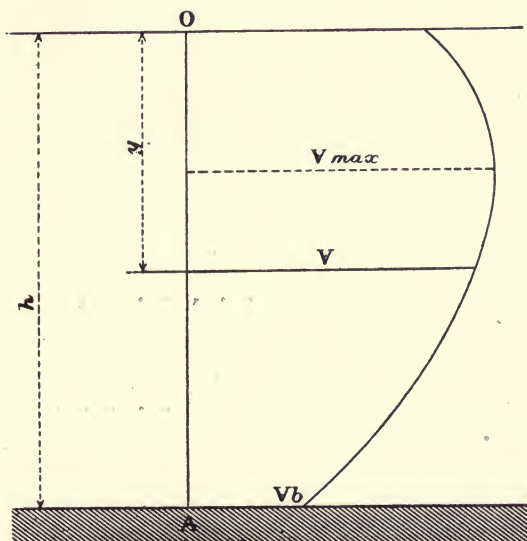

FIG. 62.

layers above ab is a retarding action. The resistance on the face cd is similarly $Kl \frac{dv}{dy} + Kl d \frac{dv}{dy}$. The resultant of the action of the layers above and below is, therefore, $Kl d \frac{dv}{dy}$.

When the motion is uniform

$$Gl dy + Kl d \frac{dv}{dy} = 0,$$

or $\frac{d^2v}{dy^2} = -\frac{Gi}{K}$; integrating, we get

$$\frac{dv}{dy} = -\frac{Gi}{K}y + C \text{ and}$$

$$v = -\frac{1}{2} \cdot \frac{Gi}{K}y^2 + Cy + v_0 \dots \dots (1)$$

an equation which gives the velocity v at any depth.

If on the vertical line OA representing the depth of the stream (fig. 62) the values of v are set off horizontally, a parabolic curve is obtained, termed the *vertical velocity curve* for the section considered. The constant v_0 is evidently the surface velocity, being the value of v , when $y=0$. The parabola has a horizontal axis corresponding to the position of the filament of *maximum* velocity. If there is *no resistance* at the surface of the stream, like that at the bottom and sides, the *maximum* velocity should be at the surface, and then $C=0$, and the equation becomes

$$v = v_0 - \frac{1}{2} \cdot \frac{Gi}{K}y^2 \dots \dots (2).$$

Assuming this for the present, the *mean velocity* is

$$v_m = \int_0^h \frac{v dy}{h} = v_0 - \frac{1}{6} \cdot \frac{Gi}{K}h^2 \dots \dots (3).$$

The *bottom velocity*, corresponding to a depth, h , is therefore, by equation (2)

$$v_b = v_0 - \frac{1}{2} \cdot \frac{Gi}{K}h^2$$

and therefore $v_m = \frac{1}{3}(2v_0 - v_b) \dots \dots (4)$.

Now assuming the general equation (1)

$$v = v_0 + Cy - \frac{1}{2} \cdot \frac{Gi}{K}y^2$$

v will have the *maximum* value V , for a value, h' , of y , which makes $\frac{dv}{dy}$ zero. That is

$$C = \frac{Gi}{K}h'$$

and the *maximum* velocity is

$$V = v_0 + \frac{1}{2} \frac{Gi}{K}h'^2$$

$$\text{Therefore, } v_o = V - \frac{1}{2} \cdot \frac{G_i}{K} h'^2$$

Unwin adds : " It is now understood that the motion in a stream is *much more complex* than the viscous theory just stated assumes. The *retardation* of the stream is *much greater* than it would be in simple motion of this kind. . . . Nevertheless, the viscous theory may probably be so modified as to furnish ultimately a true theory of streams " [Italics added].

There can, I think, be no reasonable doubt that the *general flow* of a sluggish stream is like this. Experiments on the Mississippi (probably the most accurate ever made on any large river) showed that the vertical velocity curve was a parabola, the axis of which was at a variable distance below the surface—such distance depending partly on the wind, but also, and probably *to a greater extent*, on a separate action which will be explained later. Methods of gauging rivers have been based on this property.

So far we have been discussing the *general flow* of a stream ; but, *as all the retardation* was viscous, the *resistance to this flow* varied, only, *as the velocity*. This is not the *whole truth* ; we must superpose on this another resistance varying *as the square of the velocity*.

We originally assumed our stream to have a *very small* slope. Let us now suppose the slope to be increased : the stream will, clearly, flow faster, and the *bottom velocity* become *greater*. At a certain "critical velocity" of this water along the bed—or more correctly, the *water attached to the bed*—there will be discontinuity, and eddies, or vortices, will start *from the bottom of the stream*. I have explained at considerable length in the *A B C of Hydrodynamics* (to which the reader is referred) *how* these eddies are formed by great *differences of pressure across the stream filaments*. These eddies will increase in size and spread upwards, until they occupy a considerable part of the body of the stream. Fig. 63 will give an idea of my meaning. These eddies will contain considerable *kinetic energy*, and their formation will cause a resistance which varies *as the density* of the liquid and *as the square of its velocity*. It must be remem-

bered that in the case where *all* the resistance was *viscous* there was *no generation of kinetic energy* in the stream, all the energy required to overcome viscosity being directly converted into heat.

With a greater slope the eddies will spread quite up to the surface and the stream will become a boiling torrent.

We have now a clear "general idea" of how a stream flows and how it gradually changes into a torrent. We see also why and how the resistance $=AV + BV^2$.

It is clear also that if the liquid of the river were *inviscid*,

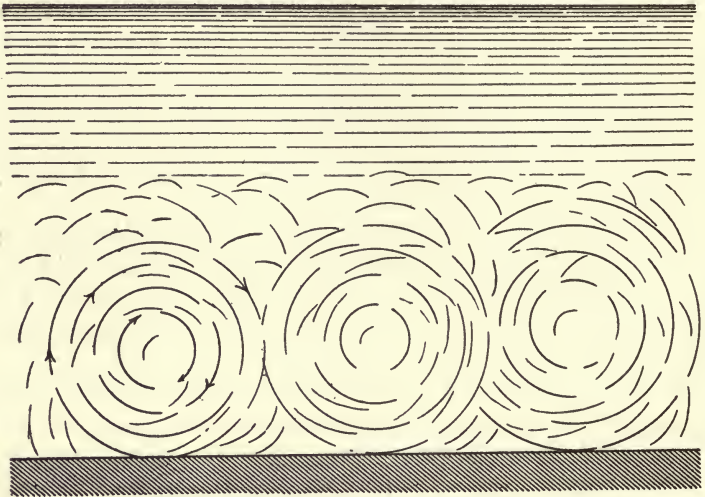

FIG. 63.

the vortices would *still be formed*, and that the *resistance to its flow* would vary as the *square of the velocity only*.

It will now be apparent, how this "secondary action" tends to lower the position of the stream filaments having the *maximum velocity*. The vortices formed at the bottom of the stream *roll on this bottom*, so that the velocity at the part *nearest the surface of the stream* will be about *double* that of the *mean velocity* of the vortices *along the bed*. This will clearly cause an *accelerating* action on the layers of fluid above, instead of a *retarding* one; and this will lower the

position of the stream filaments where $\frac{dv}{dy}$ is zero. The axis of the parabola will consequently be lowered.

Let us continue the subject and see how a river deepens its bed.

E. C. Andrews (*Journal of the Royal Society of N. S. Wales*, 1909) in his paper on *Corraison of Gravity streams*, commences by saying: “no stream moves as a rigid bolt, except possibly when falling freely.” He shows that when a stream deepens its bed, it does not do so like a plough; but rather with a kind of “scratching back” action: that it deepens it as a rabbit would deepen its hole; by *scratching*

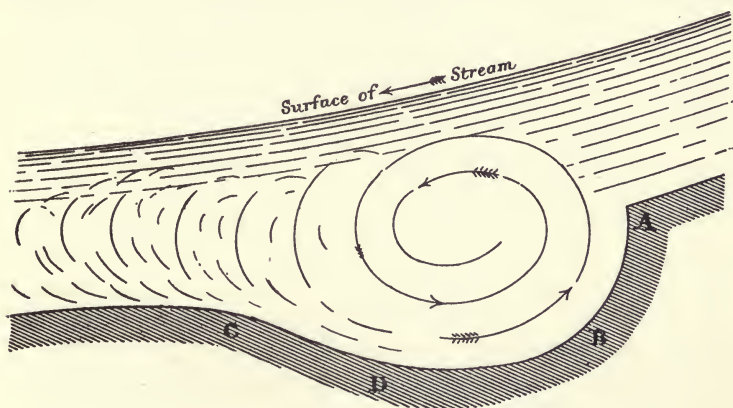

FIG. 64.

backwards, and driving the *débris backwards*. When the velocity of the stream is *checked*, by some sudden diminution in the slope of the bed, corraison takes place. The action is as shown in fig. 64, which is copied from Mr. Andrews' paper. It will be seen that the stream is “scratching backwards.” In this paper we find two laws of stream corraison.

“(1) All other things being equal, the greater the stream velocity the more will the headward profiles of the cuts formed below base level, by corraison be *inclined to the vertical*.”

“(2) The more freely does the force of gravity act, the more nearly will the basin head approach a vertical form.”

These rules, which appear to be variations of one another,

imply, of course, that in fig. 64 the slope at A B is steeper than the slope at C D. Any one who has strolled about in the bed of a dry, or even nearly dry, torrent can see for himself that where the stream has dug a hole for itself, the up-stream side of the hole is always steeper than the down-stream one. There are occasions where the difference is very small and the slopes appear to be nearly the same: *the reverse, however, is never the case*, or if it is, I have never seen it. The small stones are *forced out of the bed*¹ into the stream, in consequence of the *pressure in the stream—by reason of its velocity*—being *considerably less* than the pressure in the liquid *below the stones*, which is at rest. A very little simple arithmetic will show what *enormous* force a difference of four or five pounds per square inch can exert. The velocity of the stream passing A B is in excess of that passing C D; *consequently* there will be more erosion there, and the slope at A B will be steeper than that at C D.

In fig. 64 we see a *rapid* change of slope: the *surface water is being retarded*; and, as we have seen, when this occurs the *position of the maximum in the velocity curve* of the liquid will be *lowered*. This will also *increase* the velocity of the water *near the bed*, and the liquid will commence digging a hole. All this follows logically from what has been said previously.

Suppose, next, that the bed is of such hard rock that the water cannot lift it (speaking, popularly, as if the stones were *raised by suction*) what happens then? Supposing that the stream is carrying hard and sharp sand—which is generally the case, under such circumstances—the vortex will act like an emery wheel and *grind the surface*.

The reader may ask, why should it act like an emery wheel? Why should the grinding material be on the *rim* of the vortex rather than in any other part of it? The reply to this is to be found in the *Principia*, Prop. LIII. Theorem xli. : “ A solid, if it be of the *same density* with the *matter of the vortex*, will move with the *same motion* as the *parts thereof*, being *relatively at rest* in the matter that surrounds it. *If it be more dense*, it will endeavour *more than*

¹ By suction.

before to recede from the centre; and therefore overcoming that force of the vortex, by which, being as it were kept in equilibrio, it was retained in its orbit, it will recede from the centre, and its revolution describe a spiral, returning no longer into the same orbit. And by the same argument, if it be more rare it will approach the centre” [Italics added].

In this case the “polishing” is undoubtedly caused by “attrition”—but it is that of *solid against solid* and not *liquid against solid*.

In “hanging valleys” this “corraison” is very well seen: the small streams (having their surface water retarded) cut their beds back and so form waterfalls. This action continuing, the stream keeps cutting the base of the fall away and so working the fall backwards.

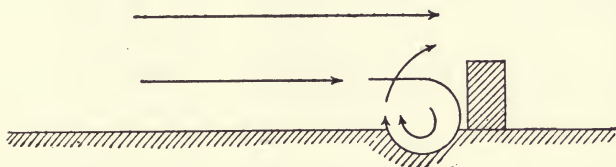

FIG. 65.

The question may be examined from another point of view which is of interest to engineers. A stream meeting the abutment of a bridge may produce this excavating action at the *front* of the abutment; and in certain cases this danger has to be provided against. There have been piers of bridges in India which have been undermined so that *they fell up stream!*

Fig. 65 from Willcock’s & Craig’s *Egyptian Irrigation* clearly explains the action against a *partly* submerged obstacle.

“In some of the large canals in India, the bed *upstream* of bridges has been scoured for miles to a depth of, perhaps, two feet below the masonry floors of the bridges which are left standing up, and forming, in fact, submerged weirs” (E. S. Bellasis, *Hydraulics*. Italics added).

Sir Arthur Cotton, who was certainly a past master in

the art of dealing with large bodies of water, used to say that you could *take your protection out vertically, or horizontally*. Most engineers take it out vertically, by very deep foundations, down to solid rock: Sir Arthur Cotton, however, built weirs across large rivers having *deep sandy beds*, without, practically, any foundations at all: he took his protection out "horizontally," by *preventing the stream attacking the sand* near the weir.

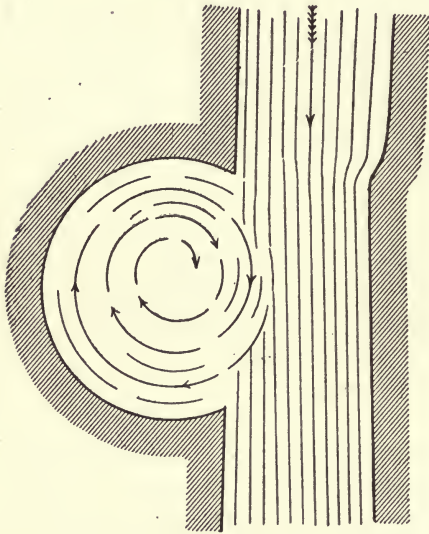

FIG. 66.

stream is caused to circle *horizontally*, as in fig. 66. When this occurs, the hole is nearly always circular; the water, circling round, being accelerated by the stream which is shown as moving past it. There is interchange of liquid between the hole and the straight part of the stream, but the interchange appears to be only partial. There are cases also where the stream acts vertically *upwards*, and I have seen very fine hemispherical domes cut out in this manner.¹

Mr. Andrews, in his paper referred to, says that the "conditions favouring the formation of deep basins (below the associated base levels) with flat-tish floors and steep sides are —

"(a) Great stream depth as compared with the width of the channel base.

"(b) Great local increase of stream velocity."

In certain cases, where there is an obstruction on one side of a torrent, the

¹ The Gorges de Sierroz on the Fier river, not far from Lake Annecy, the waters of which flow into the Fier.

There is one other point about rivers which is worth referring to, since it does not appear to be generally known ; that is, that the surface of the water, from one bank to the other, is not ordinarily terminated by a straight line, but by concave curves : that is to say, the centre is higher than the edges.

That such must be so is almost self-evident, since it follows as a logical deduction from the famous law of Bernoulli. It is well known that the velocity of flow is greater at the middle of the stream than it is near the banks : the pressure in the liquid is, therefore, *less* at the centre than at the edges. It is clear, however, that the *total* pressure *across the stream* must be the same at all parts, or there would be *flow from the edges to the centre*. This, we know, is not the case ; therefore the pressure, or *potential* energy in the liquid, must be *supplemented by some “energy of position,”* in order that equilibrium may be maintained.

The curves, which clearly must be parabolas, are usually so flat that this concavity is not noticeable by the unaided eye ; the small “hump” in the centre of the stream can, however, be frequently observed, if one looks for it. Bazin says : “there is always *in the axis of the current, a protuberance which is higher than along the edges*” (*Recherches hydrauliques*¹). This is very clearly shown in his Plate XXII figs. 2 and 8, even in the *very small* channels he was experimenting with. During the flood of some torrents, the difference in level is quite appreciable, being as much as 9 inches, or more.

It now remains to examine the question of *how a river gets round a corner*.

It is surprising that that very acute observer Dubuat should have fallen into the error of supposing that the edges of a stream, in cross section, should be level when the stream is turning round a corner. Referring to a stream flowing round a bend, he says, “if one supposes, *as is natural* (?) that the water should be at the same level at the corresponding points B, C : E, M : H, I (fig. 67), one sees that the

¹ Il existe toujours dans l'axe du courant une protubérance plus élevée que le long des parois.

slope of the water following C M I is greater than that following B E H . . . etc." The *deduction* is strictly logical, but he had started from false premisses. Streams do not flow like that.

The only other author that I know, who has treated of this subject is Professor James Thomson (*Proc. Roy. Society*, 1876). I will quote the commencement of his paper, *in extenso*, as there are parts I do not agree with.

"In respect to the origin of the windings of rivers flowing through alluvial plains, people have *usually taken the rough*

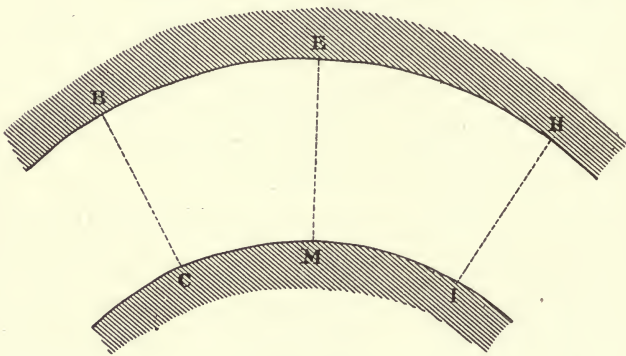

FIG. 67.

notion that when there is a bend in any way commenced, the water just rushes out against the outer bank of the river at the bend, and so washes that bank away, and allows deposition to occur on the inner bank, and thus makes the sinuosity increase. But in this they overlook the hydraulic principle, not generally known, that a stream flowing along a straight channel, and thence into a curve, must flow with a diminished velocity along the outer bank, and an increased velocity along the inner bank, IF we regard the flow as that of a perfect fluid." [Italics added].

Now, it requires some audacity to contradict such an eminent authority; but it is a matter of the commonest observation that a *real* river does *not* flow in the very least like that. I have done some "river training" and I know that the river Indus did not flow like that. The *maximum*



FIG. 68.

velocity of the stream was always *nearer the outer than the inner bank*.

I am aware of what James Thomson calls the “Hydraulic principle”; and I quite agree that, *if the liquid had no free surface*, the velocity near the *inner bank* would be in excess of that near the *outer bank*—*whether the liquid were viscous or not*. Water flows like that in a *pipe*, as is shown in fig. 68, which is copied from one of Dr. Hele-Shaw’s photographs.¹ Having a free surface, however, *changes the conditions*.

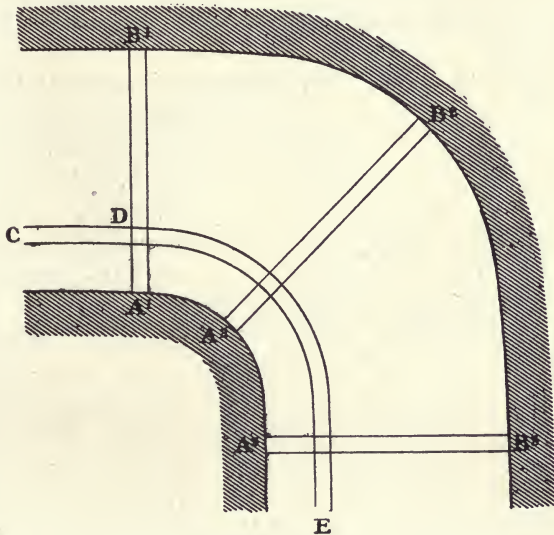

FIG. 69.

But to resume: “For any lines of particles taken across the stream at different places, as $A_1 B_1$, $A_2 B_2$, etc. (fig. 69), and which may be designated in general as $A B$, *if the line be level* [which it is not], the water-pressure must be increasing from A to B , *on account of the centrifugal force* of the particles composing the line, or *bar of water*; or, what comes to the same thing, the *water surface* of the river will have a *transverse inclination rising from A to B* .”

The paper is curious and, like everything by this eminent

¹ This is a flow of air, but water flows in the same manner.

author, well worth reading ; but it is singular how, having started from such erroneous fundamental assumptions, he should yet have arrived at correct conclusions.

Now, what are the *facts* about the flow of an ordinary river ? “ At a bend there is a ‘ set of the stream ’ towards the concave bank, the *greatest velocity* being *near that bank*.” (E. S. Bellasis, *Hydraulics*). “ It will generally be found that the *straight forward movement* of the water across to one side of the bend *implies a portion of slack water opposite*. Thus the river, moving as shown in the diagram (fig. 70), *tends to strike the bank between A and B* and to *leave slack water at C*.”

“ Scour is therefore heaviest at bends, and as the movement of the water becomes more complex there, turbulence is favoured, and the scoured material is more readily transported ” (Willcocks & Craig’s *Egyptian Irrigation*).

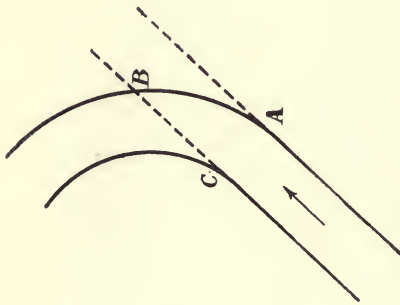

FIG. 70.

Let us now follow the motion of the water in the river and see how this comes about.

We have seen that in the straight reach the *central filament* was moving with the greatest velocity, the surface had a parabolic cross section, and the level of the water at the banks was the same ; the river had, what the French call, a *régime*. This is shown, diagrammatically, in fig. 71, where the curve is, of course, very exaggerated. A A¹ cuts the centre line of the stream, and is the axis of the parabola. The surface is represented by C A B, the ordinates of the curve (above CB) being *measures of the excess of velocity* of the liquid at different parts of the *surface* of the stream.¹

Arrived at the bend, the water moves on in a straight

¹ Just as one may say the height the water rises in a Pitot tube is a “ measure of the velocity ” of the liquid at the point of the tube.

line in consequence of its *inertia*. The “axis” of the stream will shift to DD^1 and the surface of the water will now be represented by C^1DB^1 , being heaped up against the concave bank and *lowered* at the convex bank. It is clear that equilibrium has now been destroyed; the pressures at the opposite banks are no longer equal. There is a *defect* of pressure at C^1 , whilst there is an *excess* of pressure at B^1 .

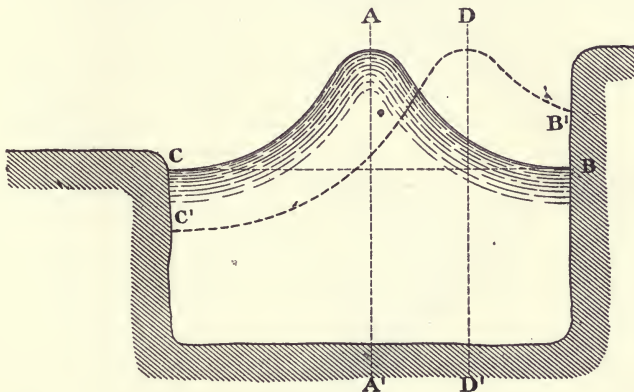

FIG. 71.

Let us first deal with C^1 : there is, what Professor James Thomson calls, “a fall of free level” here. The result of this is that water will flow from all regions of higher pressure *to this region of deficient energy*, so as to give it “energy of position”: the flow being, of course, chiefly along the bed. Referring now to fig. 72, we see the currents, represented by arrows, flowing along the bottom to C^1 . This water has, *initially, comparatively* little velocity; but in its travel towards C^1 it is gaining “energy of position” and so will be *losing some kinetic energy—its velocity will be decreasing*. “Here, in general, some of the water becomes *supersaturated* and deposits its silt” (Willcocks & Craig).

Let us now trace the action at B^1 : there is a “rise of free level” here—an excess of “energy of position.” The water will descend, losing “energy of position” and *gaining kinetic energy*. Besides this it has, what I may call, more

than its "fair share" of longitudinal velocity.¹ The result is that it excavates the bed, as described previously, only in a *diagonal direction*, as shown in section in fig. 72. This excavating action will undermine the bank, and so cause it to fall; the silt being carried away by the eddies.

Let us now see how this would appear on plan. If we represent a bend of the river by fig. 73, with the flow as shown by the arrows, the direction of the different currents along the bottom of the stream are indicated as flowing

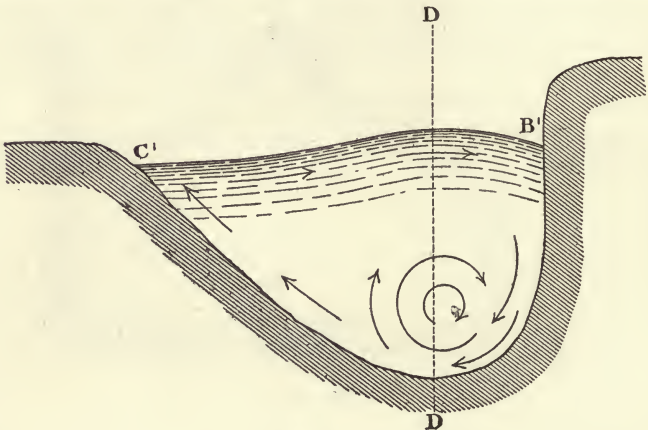

FIG. 72.

from certain spots marked by stars. It will be seen that they all cross the bed of the river and flow towards the bank where there is a *defect* of energy. Professor James Thomson showed *experimentally* that such currents actually occur.

The nett result of all this is that "the water-level at the *concave bank* is *slightly higher* than at the *convex bank*." (E. S. Bellasis, *Hydraulics*).

That the surface is convex² is *ordinarily* true; but there

¹ The surface velocity being slightly *retarded* by the bend in the river, the position of *maximum velocity* will be lowered, the *bottom velocity* being consequently *increased*.

² By "convex" I here mean that the general *surface* of the water is *above a horizontal line joining the banks*. "Concave" meaning the reverse.

are cases where it is the reverse, where the surface is *concave*. This will occur when a river is flowing into the sea during a flood tide. The tide flowing more rapidly in the centre of the river than near its banks will *retard the velocity* of the stream more there. Following the argument in the

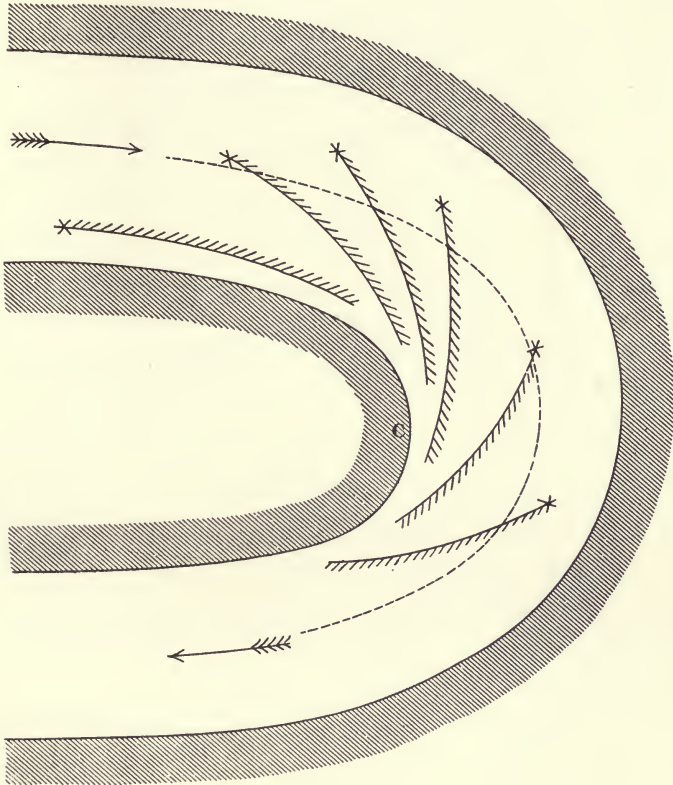

FIG. 73.

previous case, the “energy of position” will be transferred to near the banks.

Since the surface is sometimes convex and sometimes concave in cross section, it is clear that there must be cases when it is level, and that is why I carefully said the section was, *ordinarily*, convex.

SUMMARY

Resistance in rivers is *not* caused by the liquid rubbing against their beds : it is *almost entirely* caused by the liquid changing shape, and so forming "eddies."

A body floating down a stream will travel *faster* than the water surrounding and supporting it. The *excess* of velocity will depend on : (1) the *shape* of the body, and (2) its displacement in the liquid. If the body is not larger than a molecule of water, there will be *no excess* of velocity.

A river carrying ice after a thaw, or logs of timber, will flow *faster* than it would in its uncharged state.

The surface of the cross section of a flowing stream is not, ordinarily, a straight line, but is a double concave *curve* : the curvature depending on the difference between the velocity of the water in the middle of the stream and that near the banks. In some cases, however, the curvature may be the *reverse*.

REFERENCES

E. C. ANDREWS, "Corraison of Gravity Streams" (*Journal of the Royal Society of N.S.W.*, 1909).

Professor JAMES THOMSON (*Proceedings of the Royal Society*, March 14, 1876).

WILLCOCKS and CRAIG, *Egyptian Irrigation*.

E. S. BELLASIS, *Hydraulics*.

H. BAZIN, *Recherches Hydrauliques*.

CHAPTER XIV

NEGATIVE RESISTANCE IN LIQUIDS

IN discussing any scientific subject it is very difficult to avoid repeating oneself, and I cannot even plead that I have done my best to avoid doing so. I am not even quite sure that it is a disadvantage ; indeed, I cannot help thinking that many writers would make their books more intelligible if they would *insist more* on certain important points, instead of simply stating them¹ ; would, in fact, *rub them well in*. When a musician writes a symphony, he starts with certain " themes," and it is not considered wrong for him to return to them periodically. Why should this not be permissible when treating what is admittedly a complex subject ?

However, to return : I have stated previously that *all* forms of liquid resistance could be expressed by the formula $R = AV + BV^2$ —*subject to the condition that the solid is properly wetted*.

This is as old as Newton, and was the view held by Lord Kelvin—that Newton of the nineteenth century—as will be seen by reference to *Thomson and Tait*. It was also held by Sir George Stokes, who was no mean authority.

Latterly, this equation has gone out of fashion, and the idea more generally taught now is that $R = AV^n$. This expression is purely empirical, and fits experiment very

¹ " Redundancy is never necessary in logic, but it is often necessary to the correct working of our process of understanding. We know the value of *judicious repetition* when teaching."—Philip E. B. Jourdain (*The Principle of Least Action*).

indifferently ; there is, however, sign of a renaissance of the old rational formula, as may be seen in the papers issuing from the National Physical Laboratory.

It may, naturally, be asked, why was the original view abandoned ? What is there to be said against the dictum, " the resistance of a *real liquid* . . . may be expressed as *the sum of two terms, one simply as the velocity, and the other as the square of the velocity?*" (Thomson and Tait, *Natural Philosophy*. Italics added.) I have not been able to trace the history of this change of view ; but most probably it was because the term involving the first power of the velocity was *frequently found to be negative*. To explain my meaning by an example, I will quote from a paper on the resistance of water in pipes (A. C. A., 1910-11) which is expressed as $F = \rho v^2 \left(A \frac{\nu}{vl} + K \right)$; or the *total* resistance

may be rewritten as $F = \rho v^2 l^2 \left(A \frac{\nu}{vl} + K \right)$, when, by sub-

stituting $\frac{\mu}{\rho}$ for ν , the kinematic viscosity, we have

$F = A \mu (vl) + \rho K (vl)^2$; which is an equation of the same form as that given by me.

But, referring to this, it is added :—" It is evident that in the case of the rough pipe the frictional equation

$F = \rho v^2 \left(A \frac{\nu}{vl} + K \right)$ *will not hold unless A becomes negative*

with increasing roughness, for which there *does not appear to be any sufficient reason*, so that to include the cases of rough and smooth pipes an expression of the form

$$F = \rho v^2 \left(A \frac{\nu}{vl} + K + B \frac{vl}{\nu} \right)$$

appears to be necessary, in which K depends only on the roughness of the pipe."

It appears clear that what is here meant is that if A became negative, it would imply that viscosity was *reducing the resistance* and that there is *no reason to believe that this is possible*. The question of A becoming negative is certainly a difficulty ; but I cannot think that the addition of

a third term to the equation, involving v^3 , appears to afford a satisfactory way out of it. It seems to be only confusing the question still more, by adding another difficulty in the attempt to evade the first. That A *does* become negative, at times, is a fact that has to be faced and explained; it is the *expression of a physical action*, which I shall proceed to describe. It is a case of what I call "negative resistance."

The subject being curious, and not well known, it may not be uninteresting if I explain how the idea first came to me. Some eighteen or twenty years ago Mr. Yarrow very kindly gave me some very fine "speed-horse-power" curves of two torpedo boat destroyers he had just built. Being desirous of finding an equation which would satisfy these curves, I very carefully measured the ordinates at *every half knot*, and made a table of them. I then took out the first differences, as well as the second differences, and from these data I made formulæ which would *always give me the right answer*.

There was no theory implied in these formulæ, which were, frankly, *worked backwards*, without *any assumptions of any kind* beyond the accuracy of the curves. On examination I found that up to the critical velocity—what naval architects call the "hump"—they were typified by the $R=AV+BV^2$ formula; whilst, beyond that velocity, the resistance might be expressed as $R'=C+A'V$, where C was a constant. This form of equation did not surprise me at all, as it accorded with my views of the resistance of liquids. What *did* astonish me, however, was that I found that in the first formula A *was negative*! It was clear to me that to accept this was to admit that viscosity was actually *assisting the boat by reducing the resistance*. Such an idea appeared, not perhaps unnaturally, absurd; I therefore put the notes aside and thought no more of them. Some years later, when studying Colonel Beaufoy's experimental results, I again frequently came across the same idea. I eventually arrived at the conclusion that there *were* certain cases where *viscosity was actually an advantage*, and that very many curious facts connected with Hydraulics *could not be explained without this assumption*.

Although no one, that I am aware of, has explained this

“Paradox,” other writers have struck against it, without perhaps recognizing it. Mr. Lanchester (*Aerodynamics*) says, referring to the fluid at the back of the plate, “the dead water [sic] will become the seat of a lively circulation as indicated by the arrows (fig. 74), the motion of the fluid *in the vicinity of the plane being in the direction of the flight*, and that in the vicinity of the free surface being in the opposite direction. Now the *result of this will be to produce a tangential drag in a forward direction*; in fact, any skin friction experienced on the upper face or “back” of the

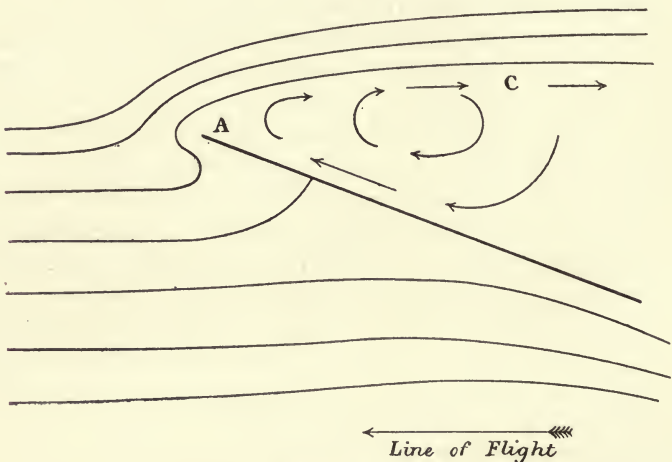

FIG. 74.

plane *will be of negative sign.*” Having said this, he leaves the subject.

Dr. Stanton, as the preceding quotation showed, appears not to have considered it *possible* for A to become *negative*, since this would imply that viscosity was actually *reducing the resistance*; he therefore thought it necessary to add a new term to his equation.

M. Soreau (*État actuel de l'aviation*), is, however, very emphatic, and says that this “counter-resistance must play an important rôle in aviation.” He refers to a curious experiment of M. Goupil as proving its existence (*La Loco-*

motion Aérienne, 1884)¹ “ a frame covered with canvas of 1 square mètre, weighing 0.70 kilogs. and loaded with a weight of 3 kilogs. was attached by two cords *m* and *n* and presented against different currents of air. When the velocity of the current was 4 m.p.s. the frame took an inclination of 45° ; at velocities of 5 and 6 mètres per second the inclination became $\frac{1}{5}$ and $\frac{1}{6}$ respectively; at 7 m.p.s. the apparatus took, to the great astonishment of the author,

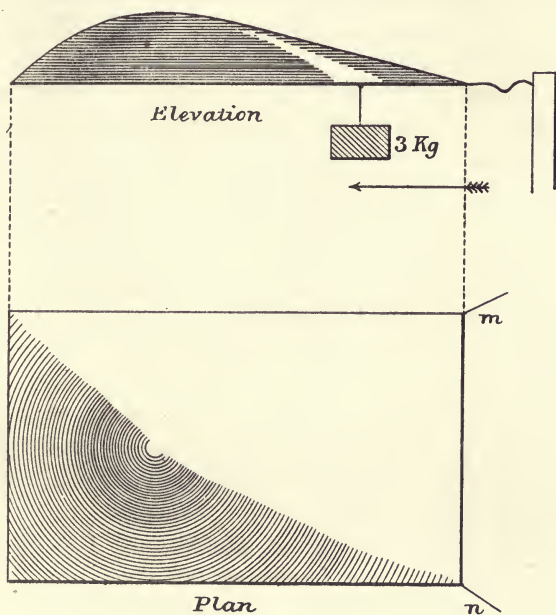

FIG. 75.

the position indicated in fig. 75: the spring-balance fixed to one of the cords *marked no traction*, and even the surface was *drawn towards the post and against the wind* (*chassait sur ses amarres contre le vent*). At greater velocities the surface again caused a considerable pull on the spring balance.” M. Soreau adds in a note that “this phenomenon has been denied, by affirming, *inaccurately*, that

¹ I have been unable to see this paper yet, and so to verify this reference.

its application to sailing flight would lead to perpetual motion."

If it were asserted that the frame *remained permanently* without strain on the spring balance ; or if it were pretended that this curious result had occurred with a *static fluid*, something might be said for this argument. The experiment, as described by M. Soreau, does not, however, appear to contain anything which is *a priori* improbable. We know so very little about the laws of resistance, of the *why* such a thing should, or should not happen. M. Eiffel has lately shown (*Comptes rendus*, 1913) that, *with spheres*, there is a "critical velocity" beyond which there is a sudden *decrease* in the resistance caused by a stream of air flowing past them ; so that the resistance is, sometimes, *actually (not relatively) less* at a slightly *increased velocity* beyond the critical one.

Captain G. Costanzi (*Alcune Esperienze di Idrodynamica*) has also shown that the same thing occurs when spheres are exposed to a current of water. Although these experiments give much food for reflection, I have not found any explanation of them which I consider at all satisfactory.

The term "negative resistance" is, admittedly, rather a barbarous one ; but since M. Soreau's "counter-resistance" is certainly no improvement, and as I know no better one, I prefer to retain "negative"—as it expresses the fact that A in the formula is negative.

In case the reader should be afraid that I am going to try and land him in the morass of "perpetual motion," I will hasten to reassure him by saying that I consider, in these cases, that viscosity acts as a kind of engine for *recuperating kinetic energy* and converting it into *work*. It acts as a *utilizer of a waste product* ; just as, by suitable means, the waste heat of a furnace can be recuperated and converted into work—through some form of heat engine—so viscosity *can*, and *does* sometimes, *recuperate* some of the *wasted kinetic energy*.

To make my meaning clearer, let A B (fig. 76) represent the section of a plate exposed to a current of liquid. Since the liquid flows past A and B, in the directions A C and B D at a velocity *considerably in excess* of that of the stream, it

is clear that *kinetic energy* has been generated there; *some of the potential energy has been converted into kinetic energy*. *All this energy is wasted*, being gradually converted into heat and so dissipated.

I may put the matter in another way. The flowing liquid exerts a pressure on the *front* of the plate; which pressure is *not counterbalanced by an equal and opposite pressure at the rear of the plate*. In other words, the liquid is *doing work*. To enable this to be done *some of the energy in the*

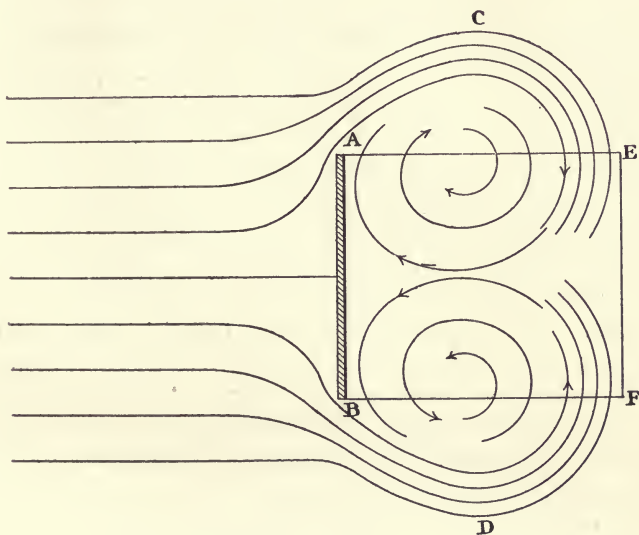

FIG. 76.

liquid must be expended. This is brought about by some of the potential energy being *converted into kinetic energy*; which kinetic energy is *subsequently converted into heat*, and so *wasted*. We may, therefore, consider the *resistance* as being *measurable by the amount of kinetic energy generated, and wasted*.

This method of considering resistance = *energy wasted* may be new to the reader. If the "Helmholtz-Kirchhoff flow" be examined in this manner it will be seen that *work is being done*, whilst *no energy appears to be expended*. This

is why I object to the assumption made in this flow.

Now, *can* any of this wasted energy be *recuperated*, and, if so, *how*? We know that eddies, or vortices, are produced behind the plate, as shown in the diagram; if we place a body like A E F B behind the plate so as to produce surfaces for these vortices, or eddies to "brush against"; there will, to a certain extent, be a *retardation* of the *cyclic motion in these vortices or eddies*, in consequence of the viscosity, stickiness, or "treachiness" of the liquid on the surface A E F B. Some of this cyclic momentum will be *converted into longitudinal momentum*, in consequence of the tangential drag; this momentum being *transferred to the body A E F B*. We have here, clearly, a *recuperation of waste energy*. Now if we consider the *resistance* of a body as being measured by *the amount of energy wasted*,¹ it will be clear that if *less is wasted*—which is the case if *some is recuperated*—the *resistance* of the body A E F B should be *less* than that of the plate *without a stern-piece*; in other words, the *resistance of the box* should be *less than that of the plate*. We know perfectly well that such is the case. An examination of the curve of resistance of a long box will show that it is satisfied by the equation $R = BV^2 - A'V$. There is, what I call, "*negative resistance*." As is commonly taught, the resistance caused by "fluid friction" *increases as the wetted surface*; whereas we see that, in this case, it is *exactly the reverse*.

To continue; if we *increase the length* of A E F B, we shall *increase the surface* for the vortices to "brush against." If the view here advanced is correct, we ought to *recuperate more energy*; *less* ought to be *wasted*; i.e., there should be *still less resistance*. This also is well known to be the case; but, as is also very well known, it is only true *up to a certain length*. If the plate is circular it is true up to a length of nearly *three diameters*, beyond this the resistance *increases* slowly. If the shape of the plate be *not* circular, then this law appears to hold good up to a length of nearly $3\sqrt{S}$, where S is the area of the surface in presentation:

¹ Neglecting the resistance due to viscosity.

more experimental work is required, however, before this can be asserted with any confidence as to its accuracy.

Colonel Beaufoy said, "among the conclusions suggested by the tables [tables of his experiments] one of the most curious is, that increasing the length of a solid, of almost any form, by the addition of a cylinder in the middle, exceedingly diminishes the resistance with which it moves, provided the weight in water continues to be the same, *a fact which I apprehend cannot be easily explained.*" Nature certainly hides some of her laws very cunningly; but I think that the foregoing is a satisfactory explanation, and it has the further merit of being exceedingly simple.

A very curious experiment in the reverse direction was tried in Washington, and is referred to by D. W. Taylor in *Speed and Power of Ships*. With a view to *reducing* "skin friction," air was pumped *around* a model through a number of small holes near the bow. The results showed that *the resistance was always materially increased!* Here again we find that *reducing the wetted surface increased the resistance: less kinetic energy was apparently recuperated.*

Let us now turn the experiment "inside out" and see if it is equally true when the liquid flows *inside the solid*; let us imagine the water flowing *through a tube*. We have seen that if a liquid flows out of a thin wall of a reservoir the discharge is very considerably less than if a short tube be attached outside the hole. Let A B in fig. 77 represent a hole in the thin wall of a reservoir, and A B C D a short tube attached to A B. Without the tube, the velocity of discharge appears to be nearly the same at all parts of the aperture. When the tube is attached, this is no longer the case—*provided that the liquid wets the tube*—since the walls

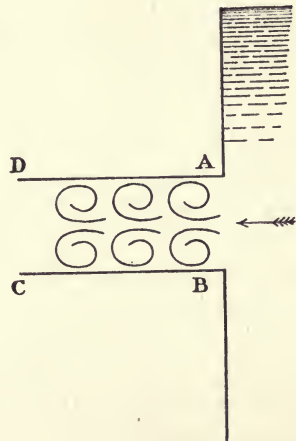

FIG. 77.

of the tube *retard the flow* and cause the liquid to *change its shape*. It now moves in a cyclic manner, as shown, diagrammatically, in fig. 77. If the tube is *very small*—capillary—the flow is not increased by this action, and the resistance varies *as the velocity only*. If the tube be *not* very small, eddies will be formed, as is well known.

As in the previous case, the viscosity *tends*, in *retarding* this cyclic motion, by tangential drag, to *transfer momentum to the tube*. Since, however, the tube is fixed, this cannot be done; so this momentum is *transferred to the liquid* instead, and the *flow of discharge is increased*. Clearly, therefore, *since the discharge is increased the resistance to this flow must have decreased*.¹

I might point to the somewhat parallel case of a locomotive. The engine in turning the wheels *tends* (provided that there be sufficient adhesion between the wheels and the rails) to *drive the rails backwards*. Since the rails are fixed, and as *something has to move*, the locomotive *goes forward*.

To return to the tube: it will not be necessary to insist much on the fact that, if this line of reasoning is correct, *lengthening* the tube should further increase the discharge, *within the limitations pointed out in the previous case*. As has been shown, experiment confirms this. We might also reasonably expect that if the tube were *very slightly corrugated longitudinally*, since the *surface of contact* between the water and the tube would be increased, the discharge should be *slightly increased*. I am not aware that this experiment has ever been tried.

In all these cases we find that viscosity is an *advantage*, in consequence of the resistance caused by it acting *in a negative direction*. Conversely, as we have seen previously, if arrangements are made so that the liquid shall *not wet the walls of the tube*—so that the viscosity shall *not act*—the increased discharge does *not take place*; the flow being as through a thin partition. Following our parallel of the

¹ As was previously pointed out, if a small hole is made in the tube, *opposite the vena contracta*, the increased discharge does *not* take place.

locomotive, if there is *no adhesion* between the wheels and the rail, the engine *will not move* along the railway track.

In November, 1912, Captain G. S. MacIlwaine, R.N., read a paper on "The Corrugated Ship" at the R.U.S. Institution. From his personal observations made *during a voyage* on the *Hiltonia*, he came to the conclusion that she consumed about 10 per cent. less fuel than an ordinary ship of the same size and with similar engines and propeller. If these observations can be relied on—and it does not appear *probable* that the author was mistaken, whilst his paper is also *most convincing*—this tends to confirm all that has been said here previously. It is a case of "negative resistance."

Captain MacIlwaine offers no explanation of why the boat *should be faster*, though he says—in the most approved classical style—"To the lay mind the *unavoidable conclusion* would appear to be that *the resistance offered by the ship has been reduced*, but we know that this is impossible! for the wetted area *has been increased*, and by long established theory resistance increases as wetted area!" [Italics added].

The reader will not be surprised if I say that I consider that reduction of the resistance is *not impossible, even though the wetted area has been increased*. I am, further, by no means satisfied that Captain MacIlwaine intended this paragraph to be taken quite seriously, for I observe two "notes of admiration," which make me rather suspect that it was "rote sarkastical." Is it not possible that when the gallant Captain penned this paragraph he had his tongue in his cheek? ¹

All these experiments show results which are *diametrically opposed* to the "fluid friction" theory; we *add* wetted surface—result, less resistance; we *increase* this wetted surface further—result, still less resistance, instead of the reverse.

We may examine this question in another way, by varying the experiment. Referring to the case of the liquid flowing out of a short tube, it was said that the viscosity *tended to drive the tube backwards*. If this is true, we should be

¹ This paper is highly interesting, and should be studied *in extenso*.

able to cause it *actually to do so*, if we arrange that the tube shall be *free to move*. In fig. 78 is shown a thin wall in a tank, in which is firmly fixed a *very short* glass tube; I suggest glass because it is smooth. Inside this small tube insert a longer glass tube, whose length $L = 3$ diameters, and which just fits loosely in the fixed tube. If we then smear the *inside* of the *short tube* and the *outside* of the longer tube with kerosine—to prevent wetting by the water—on filling the tank with water and allowing this to flow through the longer tube, it will be found that it *actually is drawn in*. In conducting this experiment it is necessary to hold the tube until a *regular* flow has commenced, as, otherwise,

it may be *driven outwards* by the *sudden rush of the water*. It is, further, necessary to release it *gradually*, as, if done too suddenly, the tube will be *drawn completely into the tank*. If the experiment is carried out properly the tube will *move inwards* for a *certain distance* and then remain in a position of stable equilibrium. When, however, the level of the water falls to *not much* above the top of the tube, the latter is slowly pushed out again.

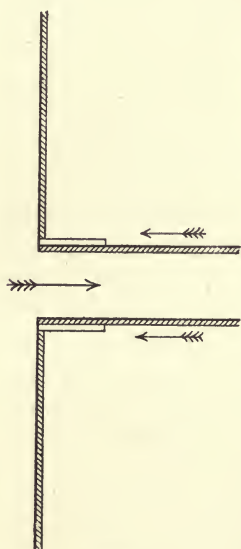

FIG. 78.

The reader may ask, why should the tube go in a *certain distance* and no further? Why should it not continue moving, until it falls into the tank? The explanation can, I think, be given by a reference to "Hamilton's principle." This is defined by

M. Poincaré (*La science et l'Hypothèse*) as follows:—

"If a system of bodies is in the situation A at the period t_0 , and in the situation B at the period t_1 , it always moves from the first situation to the second by a road such that the *mean value of the difference between the two kinds of energy*, in the interval of time which separates the two epochs t_0 and t_1 , shall be as small as possible.

“This is the principle of Hamilton, which is one of the forms of the principle of least action.”¹

Applying this to the present case; the liquid and the tube form a “system,” in which the whole energy is *initially* potential. To satisfy this principle it is clear that *for the position to be stable* the amount of *kinetic* energy generated must be a *minimum*; there must be the *least amount of energy transformed*. When the liquid flows and the tube commences to move, it is clear that it will form a “re-entrant ajutage,” and, as we have seen previously, the *discharge will be reduced*; this will continue until the discharge becomes a *minimum*; beyond this the tube will *cease to be drawn in*, the position being a *stable one*.

Still another example of this very curious action: what I may call another song to the same tune. If water is discharging over a weir, the amount of this discharge will depend, *to a great extent*, on whether air is, or is not, freely admitted beneath the sheet of water.

“Bazin . . . has investigated very fully the effect upon the discharge and upon the form of the *nappe*, by restricting the free passage of the air below the *nappe*. He finds that when the flow is sufficient to prevent the air getting under the *nappe*, it may assume one of three distinct forms, and that the discharge for one of them *may be 28 per cent. greater than when the air is freely admitted, or the nappe is free.*” (F. C. Lea, *Hydraulics*).²

This statement appears to require a little amplification and explanation: it is not by any means clear *how* the flow of water *could prevent* the air from getting under the *nappe*. What is probably meant is that the water *absorbs* the air, so that if the supply of this air is not sufficient, the water is

¹ Si un système de corps est dans la situation A à l'époque t_0 et dans la situation B à l'époque t_1 , il va toujours de la première situation à la seconde par un chemin tel que la valeur *moyenne* de la différence entre les deux sortes d'énergie, dans l'intervalle de temps qui sépare les deux époques t_0 et t_1 , soit aussi petite que possible.

C'est le principe de Hamilton, qui est une des formes du principe de moindre action.

² I have been unable to verify this reference.

forced nearer to the weir, and that it will eventually touch it, *and wet it*.

If we imagine fig. 79 (1) to represent a body of water discharging over a weir, and falling clear of it, A being a space filled with air; since the water, in falling, will suck air out of A, a strong draught will be set up from the ends of the weir to supply the deficiency of air in A. This "wind" is very well known at Niagara Falls and so requires no further comment. Suppose, now, that the ends of the fall are closed, so that air *cannot get behind the nappe*; it is clear that the water will eventually touch the front of the weir and so *wet it* (fig. 79) (2). When this occurs the same action takes

place as was described in the case of the liquid flowing through the tube: the discharge is *much increased*.

It is curious, though it may only be a coincidence, that Bazin states that this increase is 28 *per cent.*, whilst the increase in the case of a tube is given by Dubuat as about 30 *per cent.* Dubuat was, of course, well aware of the increase of discharge through an "ajutage," though he said: "It is very difficult to understand why an additional tube, of a

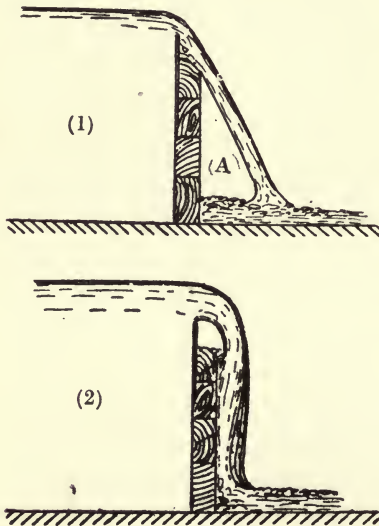

FIG. 79.

few inches in length, compels the liquid to follow its walls, and increases the discharge, through the thin wall, in the proportion of 10 to 13."

In the next chapter we will examine the curves of these resistances, so as to get a clear idea of the law which governs them.

SUMMARY

There are cases where viscosity appears to be an *advantage*; since, by acting in a *negative* direction, it can actually *reduce* resistance to motion.

Viscosity acts, in these cases, by *recuperating* what would otherwise be *wasted kinetic energy*. This is found to be true in cases of "long bodies" moving in a liquid at rest: water flowing out of pipes, *even when slightly roughened*; also in certain cases where water flows over weirs.

The resistance in such cases can be expressed by the formula.

$$R = -AV + BV^2$$

where the coefficient A of V has a *negative* value.

REFERENCES

- R. SOREAU, *État actuel de l'aviation*.
Dr. STANTON, A. C. *Aeronautics*, 1910-1911.
G. EIFFEL, *Comptes Rendus*, 1913.
Capt. COSTANZI, *Alcune esperienze di Idrodynamica*.
D. W. TAYLOR, *The Speed and Power of Ships*.
Philip E. B. JOURDAIN, *The Principle of Least Action*.
Capt. G. S. MACILWAINE, R.N., *The Corrugated Ship* (R.U.S. Inst., Nov. 1912).
H. POINCARÉ, *La science et l'hypothèse*.

CHAPTER XV

CURVES OF RESISTANCE—EXPERIMENTAL CONFIRMATION OF THEORY

LORD KELVIN said somewhere that “when you can measure what you are speaking about, and express it in numbers, you know something about it; but when you cannot measure it, when you cannot express it in numbers, your knowledge is of a meagre and unsatisfactory kind; it may be the beginning of knowledge, but you have scarcely in your thoughts advanced to the stage of science.”

In order to get a thoroughly clear knowledge of the law of resistance of liquids, it is imperatively necessary that we should be able to express it quantitatively, either numerically or by means of curves, if we wish to advance to “the stage of science.”

It is clear that the equation $R = AV + BV^2$ is the equation of a parabola, the axes of which have been shifted: the resistance therefore is *strictly parabolic*. Up to the “critical velocity,” however, the resistance varies only as the *first power of the velocity*—or $R' = AV$; and it is only *beyond* this critical velocity that this parabolic resistance commences. These two curves do not cut one another—I use the term curve in its widest sense, since $R' = AV$ is the equation to a straight line—and they only have one point common to the two, which is at the origin, where $V = 0$ (fig. 80). It is clear, therefore, that in order that the resistance, which is following the line OCV , shall shift to the parabola $MOBC^1$, it is necessary that there should be a *sudden change* in the resistance, such as from C to B .

It is very well known that such *sudden* change *does* occur at what is called the critical velocity. The curve of resistance is therefore, as shown in fig. 80 (which is reproduced from the *A B C of Hydrodynamics*) and follows OC—a

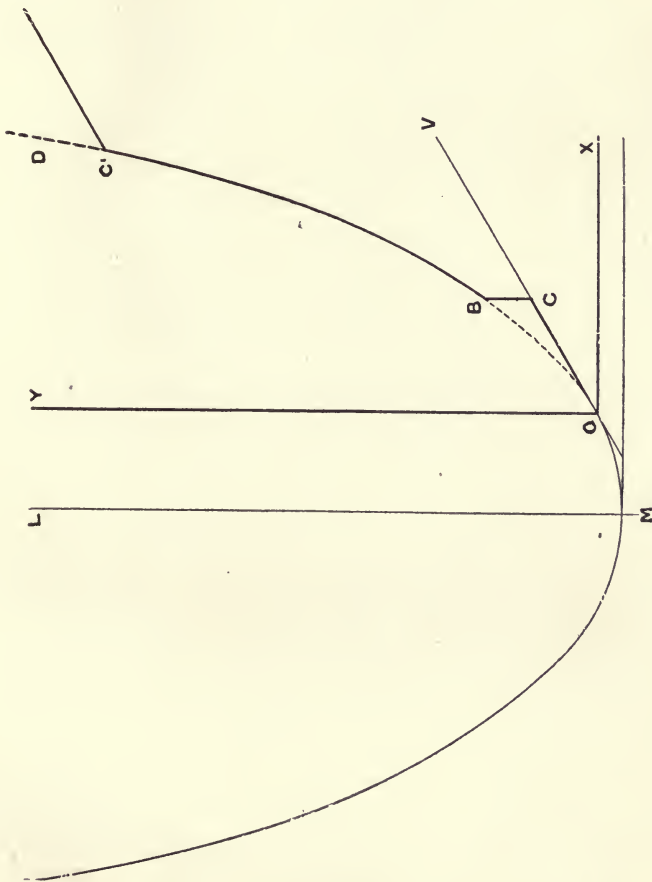

FIG. 80.

straight line—to C, which is the “critical velocity”; the resistance then takes a *sudden* leap to B, after which it follows the parabola to C¹. C¹ is a *superior* “critical velocity” which I will not refer to at present, having done so elsewhere. On examination of fig. 80 it will be easily seen

that the parabola is one whose equation would be $R'' = BV^2$, if its vertex were at O . The vertex has, however, been shifted from O to M , which is to the left and below O ; the shift being such that OCV is a tangent to the parabola at O . To obtain the curve of resistance of $R = AV + BV^2$, it is only necessary to trace the parabola $R'' = BV^2$; then lay off the line $R' = AV$; and then shift the parabola (*irrotationally*) until the line OCV is a tangent to it at O .

All this I have shown previously, but since the book went to press, Mr. Shorter pointed out to me—and proved to me mathematically—that the *locus* of the vertex of the parabola, during this shift, is the same parabola turned upside down. This is a very curious point; but I do not propose to give the mathematical proof, because I think it can be explained, much more simply, from the principle of “relative motion”; Mr. W. Child, having pointed out to me later, that *not only the vertex, but every other point in the parabola—must necessarily—describe this same parabola.*

To explain this, let BOC (fig. 81) represent a parabola, one of the thin wooden ones, such as are sold in mathematical instrument shops. It is clear that if this is placed on a sheet of paper and a pencil be run round it, the pencil will describe a parabola. Let us next suppose the pencil to be fixed and the parabola to travel past it—*irrotationally*; the axis of the parabola must *always be parallel to OY* ; then the vertex of the parabola will trace its own reflection B^1OC^1 . The simplest way to carry out the experiment is to fix a pin at O —to represent the pencil—whilst the pencil is held to the vertex of the parabola in order to trace the locus of the movement on the paper. A very little reflection—and, vastly better, a little experiment—will show that every point of the wooden parabola moves in the same manner. The reader is very strongly recommended to devote a couple of hours, or so, to tracing such curves, employing thin bodies of any shape; circles, ellipses, or irregular shapes, when he will find that they *always do this.*

I have said trace “*their reflections*”; this is not *strictly accurate*, for if there be an irregularity on the curve OC (fig. 81) it will not be shown on the curve OB^1 (which

is the strict *reflection*), but on OC^1 . *The images are not only inverted, but also reversed.*

Let us next try and get a clear image of the curve of resistance represented by the equation $R = BV^2 - AV$.

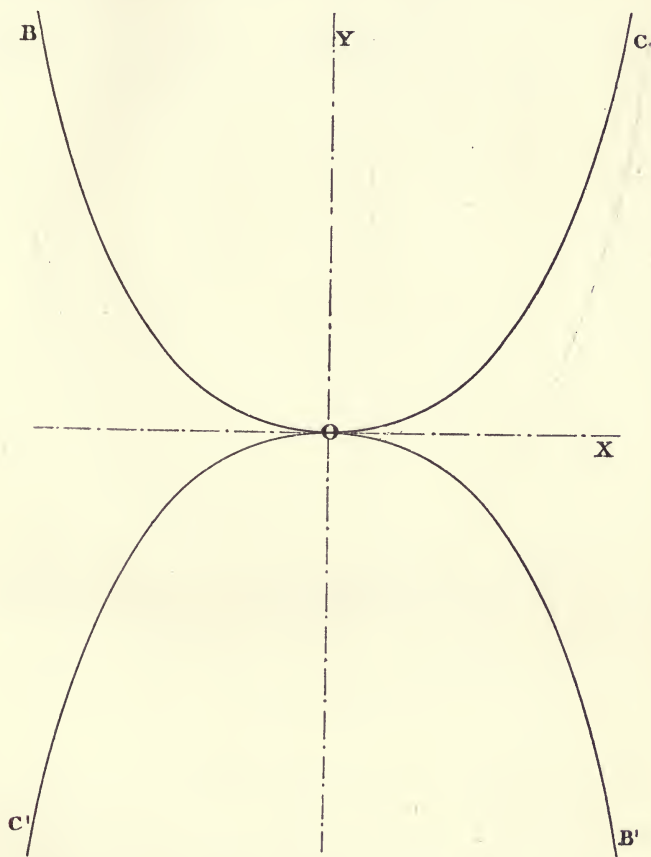

FIG. 81.

I have said, previously, that A in the curve of resistance *sometimes becomes negative*. This, also, is not *strictly accurate*, since, when A *changes its sign*, it also *changes its significance*: the A in the two equations *do not represent the same thing*, they are *not in any way related to one another*. To be accu-

rate, therefore, it is necessary to say that the curve $R=AV+BV^2$ may become $R'=-A'V+BV^2$, where A and A' are not dependent variables, and where they may, or may not, be equal to one another.

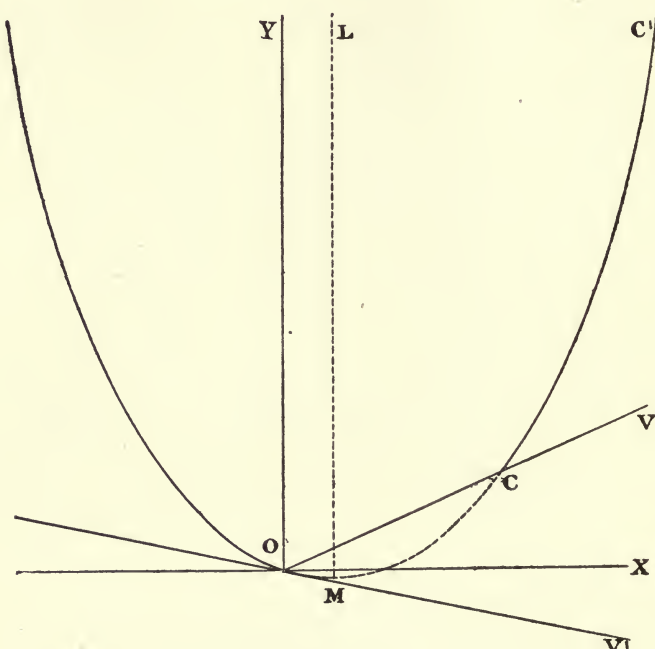

FIG. 82.

With this correction, let us now examine the curves of resistance of a "long body" the equations of resistance of which are $R=AV$ (viscous resistance only) and

$$R'=-A'V+BV^2.$$

In fig. 82 I have retained the same lettering as in fig. 80. It is clear that to trace this curve it will first be necessary to trace the parabola $R''=BV^2$, with its vertex at O . Next lay off the line OCV , whose equation is $R=AV$, and lastly the line OV^1 , the equation to which is $R'''=-A'V$. The parabola must now be shifted *down* and *to the right*, until it is tangential to OV^1 at O . The curve of resistance

of our "long body" will then be OC (a straight line) and then CC^1 , the curve of the parabola.

We have now arrived at such a point that we see that "short bodies" experience a resistance which may be expressed as $R = AV + BV^2$ —where R is *greater* than BV^2 ; in the case of "long bodies," this resistance may be expressed as $R' = -A'V + BV^2$ —where R' is *less* than BV^2 . It is clear, therefore, that there ought to be some "medium-

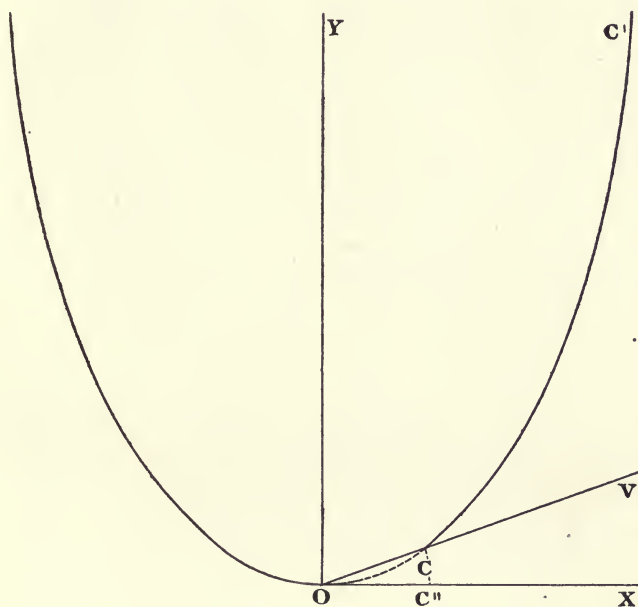

FIG. 83.

length bodies" where the resistance would be *exactly* $R'' = BV^2$. It is well known that there are. Even at the risk of tiring the reader, let us see what form the curve of resistance would take for these bodies.

Retaining the same notation, fig. 83 will represent the curve. We here lay off the parabola whose equation is $R'' = BV^2$ with its vertex at O ; and then the line OCV whose equation is $R = AV$. The curve of resistance will

then be OC —straight line—continuing along CC^1 , the parabola.

It will be observed that in the curve in fig. 80 there is *necessarily* an *abrupt* change of resistance; whilst in figs. 82 and 83 the change is *not necessarily* abrupt: the *law* changes, but there is no *necessary sudden change* in the resistance. Whether there is, or is not an *abrupt* change, will depend on whether the “critical velocity” would, or would not, put the point C *outside the parabola*. If C is *outside*, some abrupt change is, clearly, *necessary*.

To follow the question to its logical sequence, if the liquid has *no* viscosity—or if it be so small as to be a vanishing quantity—if it be what is called a “perfect” liquid; then clearly, A in the formula $R=AV$ becoming *zero*, the resistance will follow OX (fig. 83) to a point C'' (the critical velocity) when it will *suddenly* change to C and follow the parabola CC^1 . The resistance will be *zero up to the critical velocity; after which it will be parabolic*. To explain more clearly what I mean; if the Atlantic Ocean were composed of an inviscid liquid, a body moving in it at a depth of immersion of, say, 50 feet might meet with *no resistance*, up to a velocity v ; whilst at a velocity $v+dv$ it might encounter a *very considerable resistance* in consequence of the *sudden* formation of vortices.

If any reader raises the objection that he has always been taught that *in a perfect liquid there could be no resistance*, I must refer him to the *A B C of Hydrodynamics*, where I have discussed this question at considerable length. I must here content myself by saying that *this was the view held by Lord Kelvin!*

A corollary which follows from what has been here said is that, in a “perfect” or inviscid fluid a *short* body would *always* experience *less* resistance than it would in a viscous one of *the same density*; a “medium length” body, *at all velocities exceeding the critical velocity*, would meet with *exactly the same resistance in both liquids*; whilst a “long body” *at velocities exceeding the critical*, would actually experience *more resistance in the inviscid than in the viscid liquid!*



FIG. 84.

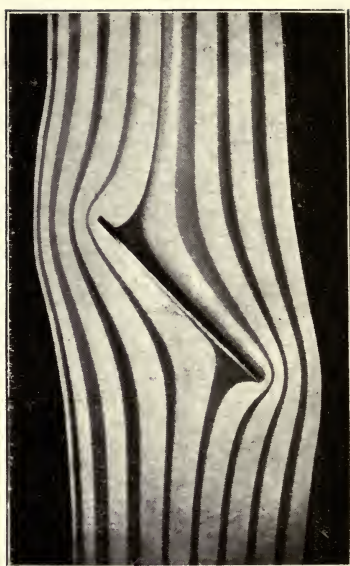

FIG. 85.

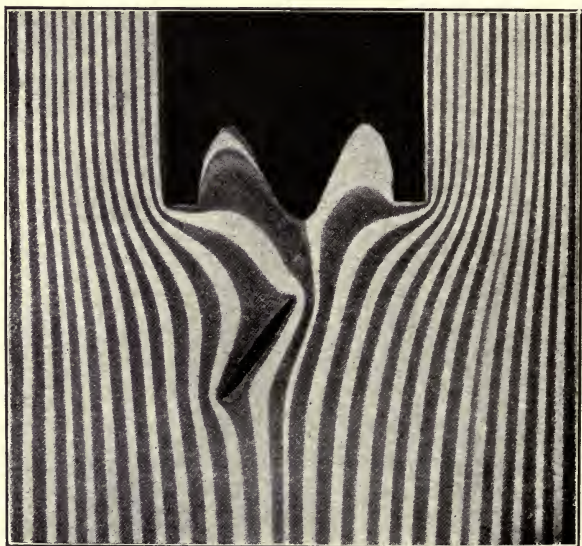

FIG. 86.

This statement will, doubtless, take many readers by surprise ; it is, however, only a *logical deduction* from what has been said previously. If we accept the premisses we must, of course, accept *all logical deductions*. I do not deny that *under certain conditions* resistance in an inviscid liquid is impossible ; I have devoted many pages to the explanation of this question elsewhere.

As previously stated, in an incompressible liquid (viscous or not) which *has no free surface, and whose envelope is inextensible, all bodies moving in it with steady motion are stream-line*. I give two examples from Dr. Hele-Shaw's *Distribution of pressure due to flow round submerged surfaces*. (Inst. Nav. Architects.)

Fig. 84 is that of a plate *at an angle* meeting a moving fluid. This is an extraordinarily beautiful picture, almost resembling a line engraving. Unfortunately, it is only a reproduction of a reproduction ; the first one having been done on very inferior paper.

Fig. 85 is the same as the last, but with the tubes of flow much larger.

Fig. 86, a very irregular figure, which would certainly not be called a "stream-line" one. We see that the fluid flows as the mathematicians say it *should*.

All these figures represent the flow of glycerine, *in two dimensions, and without a free surface*.

It will be well now to see how far experiment confirms what has been said previously. I will select a number of examples from Beaufoy. The bodies were parallelopipedons. Length, 21.099 feet, breadth and depth, 1.219 feet, immersed 6 feet and suspended from a "conductor" by iron bars ; the conductor being accelerated by weights.

In Table XXV, the figures of which are copied from Beaufoy, the 1st column gives velocity in feet per second ; the 2nd column the resistances measured—*less that of the conductor and bars*. The 3rd column gives values of $\frac{R}{V^2}$; whilst the last column gives the values of the resistance calculated by the formula

$$R = -0.73V + 1.76V^2.$$

TABLE XXV
 BEAUFOY'S EXPERIMENTS.—Page 187.
 PARALLELOPIPEDON. Square Ends. Immersion 6 ft.

V in ft. per sec.	Observed Resistance.	$\frac{R}{V^2}$	Calculated Resistance.
1	1.4453	1.445	1.03
2	6.1191	1.529	5.58
3	14.165	1.574	13.65
4	25.649	1.603	25.24
5	40.613	1.624	40.35
6	59.084	1.672	58.98
7	81.079	1.655	81.13
8	106.642	1.666	106.80
9	135.76	1.675	135.99
10	168.45	1.684	168.70
11	204.75	1.692	204.93
12	244.62	1.699	244.68

$$R = -1.73V + 1.76V^2.$$

It will be seen that the calculated and observed resistances agree very closely for all velocities *above 3 feet per second*. The reason why the results are apparently incorrect at *very low velocities* will be referred to later.

Table XXVI gives the results of the experiments carried out with the same body with a fine tailpiece. Here the resistance may be measured by $R = 1.5257V^2$, where we see that A has become = 0, whilst B has been reduced from 1.76 to 1.526; the resistance *with the tailpiece* being less than without it.

These bodies employed by Beaufoy are too long to enable us to find out the amount of *kinetic energy generated* at the head—*some of which has been recuperated and transferred to the body*—and so the examples must only be considered as “illustrations” of cases where the term involving the *first power* of V becomes *negative*.

¹ Refer to Fig. 82. OCV cuts the parabola; resistances at *low velocities* are *greater* than calculated by parabolic formula.

Table XXVII gives the results from the same body, but moving "tail first."

$$R = -.517V + .969V^2.$$

The resistance is *considerably reduced*. Possibly the amount of kinetic energy generated was considerably less than in the last case? This is a conjecture only.

TABLE XXVI

PARALLELOPIPEDON.—Page 192.

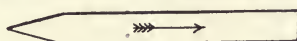
Immersion 6 ft. Angle $9^\circ 35' 40''$.

V ft. per sec.	Observed Resistance.	$\frac{R}{V^2}$	Calculated Resistance.
1	1.5034	1.5034	1.5257
2	6.0741	1.5185	6.1028
3	13.712	1.5236	13.7313
4	24.412	1.5257	24.4112
5	38.168	1.5267	38.1425
6	54.974	1.5270	54.9252
7	74.819	1.5269	74.7593
8	97.712	1.5267	97.6448
9	123.63	1.5263	123.5817
10	152.58	1.5258	152.57
11	184.54	1.5251	184.6097
12	219.54	1.5246	219.7008

$$R = 1.5257V^2.$$

Table XXVIII, results of the same body, moving in the same direction, but with a *tailpiece, blunter than the point*,

$$R = -.521V + .878V^2$$

Here, apparently, the viscosity, acting on the tailpiece, has *recuperated some more energy*.

Table XXIX, same body as the last, but direction of motion reversed¹

$$R = .31V + .76V^2$$

Apparently, here the *kinetic energy generated was less*; in any case the resistance is appreciably less.

¹ The observed and calculated values are very close. See Fig. 83.

TABLE XXVII
PARALLELOPIPEDON.—Page 201.
Immersion 6 ft. Angle $9^{\circ} 35' 40''$.

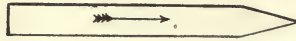

V ft. per sec.	Observed Resistance.	$\frac{R}{V^2}$	Calculated Resistance.
1	.7105	.710	.452
2	3.1380	.784	2.842
3	7.404	.822	7.170
4	13.568	.848	13.438
5	21.662	.865	21.640
6	31.714	.881	31.782
7	43.739	.892	43.862
8	57.762	.902	57.880
9	73.78	.911	73.836
10	91.82	.918	91.730
11	111.89	.924	111.562
12	133.98	.930	133.332

$$R = -517V + 969V^2.$$

TABLE XXVIII
PARALLELOPIPEDON.—Page 217.
Immersion 6 ft. Rear Angle $14^{\circ} 28' 39''$.
Front Angle $9^{\circ} 35' 40''$.

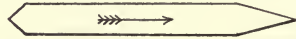

V ft. per sec.	Observed Resistance.	$\frac{R}{V^2}$	Calculated Resistance.
1	.6674	.667	.357
2	2.9013	.725	2.470
3	6.793	.755	6.339
4	12.383	.774	11.964
5	19.697	.788	19.345
6	28.748	.799	28.482
7	39.549	.807	39.375
8	52.122	.814	52.024
9	66.47	.820	66.429
10	82.59	.826	82.590
11	100.5	.831	100.507
12	120.18	.835	120.18

$$R = -521V + 878V^2.$$

¹ Calculated values less than observed. Refer to Fig. 82.

Table XXX, the original body with a fine nose and a fine tailpiece

$$R = .38V + .634V^2.$$

Again a reduction in the resistance.

TABLE XXIX

BEAUFOY.—Page 225.

Bow—Angle of Incidence = $14^{\circ} 28' 39''$.Stern—Angle of Incidence = $9^{\circ} 35' 40''$.

V ft. per sec.	Observed Resistance.	$\frac{R}{V^2}$.	Calculated Resistance.
1	0.8814	.881	1.07
2	3.4128	.853	3.62
3	7.527	.847	7.77
4	13.188	.824	13.40
5	20.368	.814	20.55
6	29.053	.807	29.22
7	39.22	.800	39.41
8	50.86	.794	51.12
9	63.96	.789	64.35
10	78.52	.785	79.10
11	94.52	.781	95.37
12	111.94	.777	113.26

$$R = .31V + .76V^2.$$

It is unnecessary to multiply examples, since doing so would not lead us any nearer to the "stage of science"; the foregoing should suffice, however, to show that in all cases the resistance follows a parabolic path, although we have not sufficient information to enable us to fix the values of A and B in the formula. We do not know *how much kinetic energy was generated*, and consequently cannot tell how much was *recuperated* by the viscosity.

It only remains now to consider why, at the very low velocities, the formulæ do not give results corresponding with the experimental figures. It is clear from figs. 82 and 83,

¹ Calculated values *greater* than observed. Refer to Fig. 80.

TABLE XXX

PARALLELOPIPEDON.—Page 209.

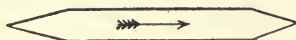
Immersion 6ft. Both angles $9^{\circ} 35' 40''$.

V ft. per sec.	Observed Resistance.	$\frac{R}{V^2}$	Calculated Resistance.
1	.7610	.7610	1.01
2	2.9399	.7349	3.29
3	6.475	.7194	6.84
4	11.333	.7083	11.66
5	17.493	.6977	17.75
6	24.937	.6927	25.10
7	33.649	.6866	33.72
8	43.622	.6816	43.61
9	54.83	.6769	54.77
10	67.29	.6729	67.20
11	80.97	.6691	80.89
12	95.87	.6588	95.85

$$R = .38V + .634V^2.$$

that the resistance at very low velocities, varying as $R = AV$ will be *in excess* of those obtained by the parabolic formula.

In the cases which refer to Fig. 80, the observed resistances are, and *should* be, *less* than those calculated by the parabolic formula.

The values in Col. 2 cannot be *accurately* called "observed"; they are *interpolations from observed results*.

There are several other forms of motion of liquids that I might have referred to, but, as Montesquieu said, "quand vous traitez un sujet, il n'est pas nécessaire de l'épuiser; il suffit de faire penser," and I hope I shall not have failed in this.

¹ Again, calculated values are greater than those observed. Refer to Fig. 80.

SUMMARY

The relation between the resistance caused by, and the velocity of a liquid may be expressed by a parabolic curve. The vertex of the parabola is not, however, generally at the intersection of the X and Y axes; nor does the *axis of the parabola*, generally, pass through this point either.

If any flat body, of *any shape*, be caused to move *irrotationally* round a fixed point, *every point in the body* will describe a figure which is an *inverted reflexion* of the body moving. That this should be so is almost self-evident; probably few people, however, are aware of it.

REFERENCES

Colonel BEAUFOY'S *Experiments*.

INDEX

- " Added mass," 112
 — — Poisson on, 113
 — — Stokes' formula, 113
 Aeroplane, action on air, 4
 Air cannot be " shot downwards " by aeroplane, 4
 Andrews on Corraison, 165
 Angle of plate, relation to " divide," 20
 Apertures, effect of exterior mouthpiece, 140
 — — re-entrant mouthpiece, 138
 — flow through (Hele-Shaw), 133
 — formula for discharge through, 131
 — movement of liquid through, 123
 Avanzini, curves of vortices, 17
 — experiment on velocity head, 38
 — on " divide," 14
 Bazin on floating bodies, 157
 — on weir discharge, 189
 Beaufoy's experiments, 199
 Bellangé pump, 151
 Bellasis on flow of streams round curves, 172
 Bernoulli, movement of liquid through apertures, 124
 — on rise of water in a tube, 146
 Bidone, coefficient of discharge, 136
 Bossut, experiments on jets, 93, 101
 — — on velocity head, 36
 — on *vena contracta*, 127
 Canals, flow of water in, 155
 Cat, on Seville pump, 157
 Centre of pressure of an immersed plate, 17
 Circular plate, position of " divide," 9
 Coefficient of contraction, 134
 — — de Borda, 134
 — — Unwin, 134
 — of discharge, 136
 Coefficient of discharge, de Borda 136
 — — through greased tube, 137
 — — through wetted tube, 137
 Conservation of momentum, defined, 5
 Corraison of streams, 165
 Corrugated ship (MacIlwaine), 186
 Coulomb's formula for liquid resistance, 154
 Critical velocity (Eiffel), 182
 Curves of resistance, 192
 d'Alembert, on use of mathematics, 12
 de Borda, coefficient of contraction, 134
 — coefficient of discharge, 136
 — coefficient of discharge through apertures, 144
 — experiment on tube in liquid, 145
 — movement of liquid through apertures, 125
 — on rise of water in a tube, 147
 — on velocity head, 43
 — *re-entrant ajutage*, 133
 de Grammont, experiments with plates in air, 69
 de Louvrié's formula, 105
 Definitions, conservation of energy, 5
 — — of momentum, 5
 — dynamic pressure, 46
 — Hamilton's principle, 188
 — impact, 7
 — jet (Osborne Reynolds), 86
 — — (Unwin), 86
 — kinetic head, 46
 — potential energy, 46
 — push or pull, 5
 — shock, 80
 — static liquid, 43
 — static pressure, 80
 — stream line body (Lanchester), 115
 — velocity head, 28, 46

- Density, effect on resistance, 2
 Deviation of water in front of plate, 26
 Dewar's experiment with ball and air jet, 109
 Discharge through aperture, formula for, 131
 "Divide," Dubuat on, 9-14.
 — position of, at different angles, 21
 — — Avanzini, 14
 — — on circular plate, 9
 — — on rectangular plate, 11
 — — on square plate, 10
 — relation to angle of plate, 20
 Dubuat, experiment on funnel, with and without diaphragm, 66
 — on the "liquid prow," 26
 — — on velocity head, 38
 — — with body at rest, 57
 — — with jets, 88
 — — with partially immersed body, 58
 Dubuat's paradox, 51
 — — explained, 110
 — Pitot tube experiment, 68
 Duchemin and Dubuat's experiments compared, 48, 49
 — experiments on Pitot tube, 63
 — — on potential and velocity head, 47
 — — on stream filaments, 26
 — — on velocity head, 33
 — — with body at rest, 55
 — flow of water past side of body, 76
 — formula, 102
 — — for velocity head, 30
 — on deviation of water in front of plate, 26
 — on motion of stream filaments round plate, 23
 — on plates at an angle, 18
 — on position of divide, 9-14
 Dynamic pressure defined, 46
 Dynamical similarity formula, 2
 Eddies, affected by length of body, 24
 — formation of, in streams, 163
 — shape of, behind plate, 23
 — — not altered by change of velocity, 23
 Eiffel on "critical velocity" in air, 182
 — on Dubuat's paradox, 60
 — stream lines, 119
 Empirical law of resistance, 3
 Energy, cannot be defined, 6
 — conservation of, 5
 — relation of potential and kinetic, 6
 Eulerian theory, 114
 Fanning on coefficient of discharge, 139
 — on discharge through aperture, 132
 Floating bodies, Bazin on, 157
 — — velocity of stream increased by, 159
 — — position of, in rivers, 158
 — — velocity of, 157
 Flow of a stream, 163
 — of liquid behind plate, 70
 — of rivers, 159
 — of water at side of body, 76
 — — in rivers and canals, 155
 — — past edge of plate, 72
 Formulæ, centre of pressure of jets (Rayleigh), 102
 — de Louvrié's, 105
 — discharge through aperture, 131
 — Duchemin's, 102
 — dynamical similarity, 2
 — empirical, for resistance, 3
 — Goupil's, 106
 — Joessel's, 105
 — Kirchhoff-Rayleigh, 106
 — length of pendulum, 111
 — liquid resistance (Coulomb), 154
 — pressure of jets, 93, 96
 — Rayleigh's, for position of "divide," 21
 — Renard's, 106
 — Stokes's for added mass, 113
 — velocity head, 48
 — velocity head (Duchemin), 30
 — von Lössl's, 106
 Froude, on leeway of a ship, 121
 — on *vena contracta*, 129
 Goupil's experiment, 180
 — formula, 106
 Hamilton's principle defined, 188
 Hele-Shaw's experiments, 199
 — experiment on flow through an aperture, 133
 — on bodies in a viscous liquid, 115
 Hero's fountain, 150
 Horizontal jets, 93
 Impact defined, 7

- Jet defined, 86
 — pressure of, on a plate, 86
 — striking a plate, effect of, 86
 Jets, Bossut's experiments, 93, 101
 — formula for pressure of, 93, 96
 — Dubuat's experiments, 88
 — horizontal, 93
 — maximum pressure per unit area, 91
 — Michelotti's experiments, 94
 — Morosi's experiments, 97
 — refluxed, pressure of, 97
 — static and non-static, 68, 88
 — striking plates at an angle, 100
 — Vince's experiments, 96, 100
 Joessel's formula, 105
- Kent on Pitot tube formula, 69
 Kinetic energy, relation to potential energy, 6
 Kinetic head defined, 46
 Kirchhoff-Rayleigh formula, 106
- Lanchester on relative motion, 52
 — on stream line body, 115
 Lea on Pitot tube, 69
 Leeway of a ship, 121
 Length of body, effect of, on eddies, 24
 — effect on resistance, 83
 Lilienthal, diagram of stream lines, 119
 Liquid friction indefinable, 3
 "Liquid prow" of Dubuat, 26
- MacIlwaine, corrugated ship, 186
 Marey on stream lines, 117
 Maxim on action of aeroplane on air, 4
 Michelotti, experiments on jets, 94
 — on influence of mouthpiece on discharge, 145
 — on movement of liquid through an orifice, 130
 Mississippi, vertical velocity curve, 163
 Momentum, conservation of, 5
 Morosi's experiment on jets, 97
 Mouthpieces increase discharge, 143
- Negative resistance in liquids, 177
 Newton on movement of liquid through apertures, 123
 — on *vena contracta*, 127
 — on resistance of fluids, 1
 Nollet, report on Seville pump, 152
- Non-static jets, 68, 88
 — liquid, reflux in, 117
- Osborne Reynolds, definition of a jet, 86
- Parabolas, experiments with, 196
 Partially immersed plate, 12
 Pearson (Karl), definition of push or pull, 5
 Pendulums, properties of, 110
 — swinging in liquid, 111, 112
 Pitot tube, character of pressures recorded by, 46
 — — Duchemin experiment on, 62
 — — Dubuat's modification, 26
 — — effect of bell mouth, 64
 — — effect of plate round orifice, 63
 — — formula, Kent, 69
 — — properties of, 28
 — — Unwin on, 64
 Poincaré, on energy, 7
 — on Hamilton's principle, 188
 — on relative motion, 70
 Poisson on "added mass," 113
 Potential energy, relation to kinetic energy, 6
 — head, defined, 46
 — — Duchemin's experiments, 47
 Pressures behind a moving plate, 82
 Prony's formula for liquid resistance, 155
 Push, defined, 5
- Rayleigh, centre of pressure of jets, 102
 — formula for position of divide, 21
 Rear pressure, increased by lengthening of a body, 84
 — — on a body, 85
 Rectangular plate, position of "divide," 11
Re-entrant ajutage (de Borda), 133
 — mouthpiece, effect of adding plate to, 145
 Reflux in non-static liquid, 117
 Refluxed jets, pressure of, 97
 Relation of potential and kinetic energy, 6
 Relative motion, 51
 — Poincaré, 70
 Renard's formula, 106
 Resistance, curves of, 192
 — decreased by increase of length of body, 185
 — empirical law for, 3

- Resistance of a stream, 163
 — of liquids composed of two terms, 2
 — — Coulomb's formula, 154
 — — (Newton), 1
 Prony's formula, 155
 — — reduced by viscosity, 179
 — — Stokes, 156
 Riabouchinsky on undulatory pressure, 42
 — stream lines, 118
 Rivers, flow of water in, 154
 — manner of flow of, 159
 — position of floating bodies in, 158
- Sée, on relative motion, 52
 Seville pump, 150
 Shock, defined, 80
 Soddy on energy, 7
 Soreau on counter resistance, 180
 Spheres, critical velocity with, 182
 Square plate, position of divide, 10
 Static and non-static jets, 68, 88
 Static liquid defined, 43
 — — flow of, without reflux, 116
 — — Stokes, 45
 — — pressure defined, 80
 Stokes' formula for added mass, 113
 — on liquid resistance, 156
 — on static liquid, 45
 — proportionate resistance of bodies, 3
 Stream-filaments, direction of flow of, 23
 — — Duchemin's experiment, 26
 — — motion round plate, 23
 — — velocity of, 26
 Stream-line body defined, 115
 — — bodies (Hele-Shaw), 199
 — — lines, Eiffel, 119.
 — — Hele-Shaw, 116, 118
 — — Marey, 117
 — — Riabouchinsky, 118
 — — von Lössl, 119
 Streams, action on submerged obstacles, 167
 — formation of basins in, 168
 — — of eddies in, 163
 — nature of flow of, 163
 — position of maximum velocity in curves, 171
 — surface curvature, 169
 Surface curvature of streams, 169
 Syphon, oscillation of water in, 112
- Thomson, Prof. J., on flow of streams round curves, 170
 Tubes of flow, 133
- Undulatory pressure, Riabouchinsky, 42
 Unwin, coefficient of contraction, 134
 — definition of a jet, 86
 — on exterior mouthpieces, 180
 — on flow of rivers, 159
 — on Pitot tube, 65
 — on pressure of a current on a plane, 65
 — on the pressure of a jet, 86
 — on resistance of a plane moving through a fluid, 65
 — on *vena contracta*, 128
- Velocity curve of Mississippi, 163
 — head, Avanzini's experiment, 39
 — — Bossut's experiments, 36
 — — de Borda, 43
 — — defined, 28, 46
 — — Dubuat's experiments, 38
 — — Duchemin's experiment, 33, 47
 — of floating bodies in streams, 159
 — of stream filaments, 26
Vena contracta, Bossut, 127
 — — explained, 127
 — — Hachette's experiment, 129
 — — Newton's experiments, 127
 — — Unwin, 128
 Vince, experiment on jets, 96, 100
 — experiment on planes at an angle, 108
 — whirling table experiments, 69
 Viscosity, effect on resistance, 2
 — reduces resistance, 179
 — recuperative action of, 191
 von Lössl, experiment on planes at an angle, 107
 — — stream lines, 119
 von Lössl's formula, 106
 Vortices, curves of, Avanzini, 17
- Water, not pushed forwards by body, 4
 Weir, discharge of water over, 189
 Weisbach, coefficient of discharge, 136
 Wetted tubes, 137
 Whirling table experiments (Vince), 69
 Willcocks, on flow of streams round curves, 172
- Zahm on impact of a jet of water, 67
 — on pressure of a jet, 87
 — on relative motion, 52

A SHORT LIST OF SCIENTIFIC BOOKS

PUBLISHED BY

E. & F. N. SPON, Limited,

57, Haymarket, London, S.W.

SOLE ENGLISH AGENTS for the Books of—

MYRON C. CLARK, NEW YORK

SPON & CHAMBERLAIN, NEW YORK

	PAGE		PAGE
AGRICULTURE	2	LOGARITHM TABLES	25
ARCHITECTURE.. .. .	2	MANUFACTURES	22
ARTILLERY	4	MARINE ENGINEERING	26
AVIATION	4	MATERIALS	27
BRIDGES AND ROOFS	5	MATHEMATICS	28
BUILDING	2	MECHANICAL ENGINEERING	29
CEMENT AND CONCRETE	7	METALLURGY	32
CIVIL ENGINEERING	8	METRIC TABLES	33
CURVE TABLES	11	MINERALOGY AND MINING	33
DICTIONARIES	11	MISCELLANEOUS	47
DOMESTIC ECONOMY	12	MODEL MAKING	35
DRAWING	12	MUNICIPAL ENGINEERING	39
EARTHWORK	13	NAVAL ARCHITECTURE	26
ELECTRICAL ENGINEERING	13	ORGANIZATION	36
FOREIGN EXCHANGE	18	PHYSICS	36
GAS AND OIL ENGINES	19	PRICE BOOKS	37
GAS LIGHTING	19	RAILWAY ENGINEERING	37
HISTORICAL: BIOGRAPHICAL	20	SANITATION	39
HOROLOGY	20	STRUCTURAL DESIGN	5
HYDRAULICS; PUMPS	21	TELEGRAPH CODES	41
INDUSTRIAL CHEMISTRY.. .. .	22	USEFUL TABLES	45
INSTITUTIONS	48	WARMING: VENTILATION	41
INTEREST TABLES	24	WATER SUPPLY	42
IRRIGATION	25	WORKSHOP PRACTICE	43

All books are bound in cloth unless otherwise stated.

NOTE: The Prices in this Catalogue apply to books sold in the United Kingdom only.

AGRICULTURE

- Hemp.** A Practical Treatise on the Culture for Seed and Fibre. By **S. S. Boyce.** 13 illus., 112 pp., crown 8vo. (*New York, 1900.*) 2s. 6d. net.
- Farm Drainage.** By **H. F. French.** 100 illus., 284 pp., crown 8vo. (*New York, 1904.*) 4s. 6d. net.
- Talks on Manures.** By **J. Harris.** New edition, 366 pp., crown 8vo. (*New York, 1893.*) 6s. 6d. net.
- Coffee, its Culture and Commerce in all Countries.** By **C. G. W. Lock.** 11 plates, 274 pp., crown 8vo. (*1888.*) 12s. 6d.
- Sugar, a Handbook for Planters and Refiners.** By the late **J. A. R. Newlands** and **B. E. R. Newlands.** 236 illus., 876 pp., 8vo. (*1909.*) £1 5s. net.
- Hops, their Cultivation, Commerce and Uses.** By **P. L. Simmonds.** 143 pp., crown 8vo. (*1877.*) 4s. 6d.
- Estate Fences, their Choice, Construction and Cost.** By **A. Vernon.** Re-issue, 150 illus., 420 pp., 8vo. (*1909.*) 8s. 6d. net.

ARCHITECTURE AND BUILDING

- The Hydropathic Establishment and its Baths.** By **R. O. Allsop.** 8 plates, 107 pp., demy 8vo. (*1891.*) 5s.
- The Turkish Bath, its Design and Construction.** By **R. O. Allsop.** 27 illus., 152 pp., demy 8vo. (*1890.*) 6s.
- The Builder's Clerk.** By **T. Bales.** Second edition, 92 pp., fcap. 8vo. (*1904.*) 1s. 6d.
- Glossary of Technical Terms used in Architecture and the Building Trades.** By **G. J. Burns.** 136 pp., crown 8vo. (*1895.*) 3s. 6d.
- Chimney Design and Theory.** By **W. W. Christie.** Second edition, 54 illus., 200 pp., crown 8vo. (*New York, 1902.*) 12s. 6d. net.
- Approximate Estimates.** By **T. E. Coleman.** Third edition, 481 pp., oblong 32mo, leather. (*1907.*) 5s. net.

- Stable Sanitation and Construction.** By **T. E. Coleman.** 183 illus., 226 pp., crown 8vo. (1897.) 3s. net.
- House Plans and Building Construction for General Contractors and House Builders.** By **M. M. Dustman.** 511 illus., 239 pp., oblong folio. (*New York, 1912.*) 8s. 6d. net.
- Building Construction Drawing.** By **Richard B. Eaton.** In Two Parts. Imperial 8vo, limp. (1914.)
Part I. 26 plates, 59 pp. 1s. 6d. net.
Part II. 1s. 6d. net.
- Architectural Examples in Brick, Stone, Wood and Iron.** By **W. Fullerton.** Third edition, 245 plates, 254 pp., demy 4to. (1908.) 15s. net.
- Building Supervision.** By **Geo. W. Grey.** x + 146 pp., crown 8vo. (1913.) 2s. 6d. net.
- The Clerk of Works' Vade Mecum.** By **G. G. Hoskins.** Eighth edition. (1914.) 1s. 6d. net.
- A Handbook of Formulæ, Tables, and Memoranda for Architectural Surveyors.** By **J. T. Hurst.** Fifteenth edition, new impression, 112 illus., viii + 512 pp., royal 32mo, roan. (1912.) 5s. net.
- Paint and Colour Mixing.** By **A. S. Jennings.** Fourth edition, 14 col. plates, 190 pp., 8vo. (1910.) 5s. net.
- Quantity Surveying.** By **J. Leaning.** Fifth edition, new impression, 936 pp., 8vo. (1912.) £1 5s. net.
- Builders' Quantities.** By **H. M. Lewis.** 6 illus., 44 pp., crown 8vo. (S. & C. SERIES, No. 40.) (1911.) 1s. 6d. net.
- Obstruction to Light.** A Graphic Method of determining Problems of Ancient Lights. By **H. B. Molesworth.** 9 folding plates, 4to. (1902.) 6s. net.
- Suburban Houses.** A series of practical plans. By **J. H. Pearson.** 46 plates and 12 pp. text, crown 4to. (1905.) 5s. net.
- Solid Bitumens, their Physical and Chemical Properties.** By **S. F. Peckham.** 23 illus., 324 pp., 8vo. (*New York, 1909.*) £1 1s.
- Roman Architecture, Sculpture and Ornament.** By **G. B. Piranesi.** 200 plates, reproduced in facsimile from the original. 2 vols., imperial folio, in wrappers. (1900.) £2 2s. net.

- The Seven Periods of English Architecture**, defined and illustrated. By **E. Sharpe**. Third edition, 20 steel plates, royal 8vo. (1888.) 12s. 6d.
- Our Factories, Workshops and Warehouses**, their Sanitary and Fire-Resisting Arrangements. By **B. H. Thwaite**. 183 illus., 282 pp., crown 8vo. (1882.) 9s.
- Elementary Principles of Carpentry**. By **T. Tredgold** and **J. T. Hurst**. Eleventh edition, 48 plates, 517 pp., crown 8vo. (1904.) 7s. 6d. net.
- Practical Stair Building and Handrailing**. By **W. H. Wood**. 32 plates, 91 pp., crown 4to. (1894.) 10s. 6d.
- Spons' Architects' and Builders' Pocket Price-Book and Diary, 1913**. Edited by **Clyde Young**. Revised by **Stanford M. Brooks**. Forty-first ed., viii + 308 pp., 16mo, green leather cloth (size 6½ in. by 3¼ in. by ½ in. thick). 2s. 6d. net.
- Spons' Practical Builders' Pocket Book**. Edited by **Clyde Young** and **Stanford M. Brooks**. 74 illus., viii + 456 pp., 16mo, maroon leather cloth (1914). 5s. net.

ARTILLERY

- Guns and Gun Making Material**. By **G. Ede**. xii + 74 pp., crown 8vo. (1889.) 6s.
- Treatise on Application of Wire to Construction of Ordnance**. By **J. A. Longridge**. 180 pp., 8vo. (1884.) £1 5s.

AVIATION

- The Atmosphere, its Characteristics and Dynamics**. By **F. J. B. Cordeiro**. 35 illus., 129 pp., small 4to. (*New York, 1910.*) 10s. 6d. net.
- Theory and Practice of Model Aeroplaning**. By **V. E. Johnson**. 61 illus., xvi + 148 pp., crown 8vo. (1910.) 3s. 6d. net.
- The Gyroscope, An Experimental Study**. By **V. E. Johnson**. 34 illus., 40 pp., crown 8vo. (S. & C. SERIES, No. 22.) (1911.) 1s. 6d. net.

- Natural Stability and the Parachute Principle in Aeroplanes.** By **W. Le Maitre.** 34 illus., 48 pp., crown 8vo. (S. & C. SERIES, No. 39.) (1911.) 1s. 6d. net.
- How to Build a 20-ft. Bi-plane Glider.** By **A. P. Morgan.** 31 illus., 60 pp., crown 8vo. (S. & C. SERIES, No. 14.) (New York, 1909.) 1s. 6d. net.
- Flight-Velocity.** By **A. Samuelson.** 4 plates, 42 pp., 8vo, sewed. (1906.) 2s. net.
- Resistance of Air and the Question of Flying.** By **A. Samuelson.** 23 illus., 36 pp., 8vo, sewed. (1905.) 2s. net.
- The Laws of Avanzini.** Laws of Planes moving at an angle in air and water. By **Lieut.-Col. R. de Villamil.** 2 folding plates, 3 illus., 23 pp., super royal 8vo, sewed. (1912.) 2s. net.
- Aeroplanes in Gusts, Soaring Flight and Aeroplane Stability.** By **S. L. Walkden.** Second Edition. 4 plates, 47 illus., xvi + 188 pp., 8vo. (1913.) 12s. 6d. net.

BRIDGES, ARCHES, ROOFS, AND STRUCTURAL DESIGN

- Strains in Ironwork.** By **Henry Adams.** Fourth edition, 8 plates, 65 pp., crown 8vo. (1904.) 5s.
- Designing Ironwork.** By **Henry Adams.** Second series. 8vo, sewed.
- Part I. A Steel Box Girder. (1894.) 9d. net.
 - „ II. Built-up Steel Stanchions. (1901.) 1s. 3d. net.
 - „ III. Cisterns and Tanks. (1902.) 1s. net.
 - „ IV. A Fireproof Floor. (1903.) 1s. net.
- Columns and Struts.** Theory and Design. By **Wm. Alexander.** 101 illus., xii + 265 pp., demy 8vo. (1912.) 10s. 6d. net.
- A Practical Treatise on Segmental and Elliptical Oblique or Skew Arches.** By **G. J. Bell.** Second edition, 17 plates, 125 pp., royal 8vo. (1906.) £1 1s. net.
- Economics of Construction in relation to Framed Structures.** By **R. H. Bow.** Third thousand, 16 plates, 88 pp., 8vo. (1873.) 5s.
- Theory of Voussoir Arches.** By **Prof. W. Cain.** Third edition, 201 pp., 18mo, boards. (New York, 1905.) 2s. net

- New Formulæ for the Loads and Deflections** of Solid Beams and Girders. By **W. Donaldson**. Second edition, II illus., viii + 56 pp., 8vo. (1872.) 4s. 6d.
- Plate Girder Railway Bridges**. By **M. Fitzmaurice**. 4 plates, 104 pp., 8vo. (1895.) 6s.
- Pocket Book of Calculations** in Stresses. By **E. M. George**. 66 illus., 140 pp., royal 32mo, half roan. (1895.) 3s. 6d.
- Tables for Roof Framing**. By **G. D. Inskip**. Second edition, 451 pp., 8vo, leather. (New York, 1905.) 12s. 6d. net.
- Stresses in Girder and Roof Frames**, for both dead and live loads, by simple Multiplication, etc. By **F. R. Johnson**. 28 plates, 215 pp., crown 8vo. (1894.) 6s.
- A Graphical Method for Swing Bridges**. By **B. F. La Rue**. 4 plates, 104 pp., 18mo, boards. (New York, 1904.) 2s. net.
- Bridge and Tunnel Centres**. By **J. B. McMasters**. Illustrated, 106 pp., 18mo, boards. (New York, 1893.) 2s. net.
- Notes on Cylinder Bridge Piers** and the Well System of Foundations. By **J. Newman**. 144 pp., 8vo. (1893.) 6s.
- Calculation of Columns**. By **T. Nielsen**. 4 plates, 36 pp., 8vo. (1911.) 4s. 6d. net.
- A New Method of Graphic Statics** applied in the Construction of Wrought Iron Girders. By **E. Olander**. 16 plates, small folio. (1887.) 10s. 6d.
- Steel Bar and Plate Tables**. Giving Weight of a Lineal Foot of all sizes of L and T Bars, Flat Bars, Plates, Square and Round Bars. By **E. Read**. On large folding card. (1911.) 1s. net.
- Reference Book for Statical Calculations**. By **F. Ruff**. With diagrams, 140 pp., crown 8vo. (1906.) 5s. net.
- Suspension Bridges and Cantilevers**. By **D. B. Steinmann**. vii + 185 pp., 18mo, boards. (VAN NOSTRAND SERIES, No. 127.) (New York, 1911.) 2s. net.
- The Anatomy of Bridgework**. By **W. H. Thorpe**. 103 illus., 190 pp., crown 8vo. (1906.) 6s. net.

CEMENT AND CONCRETE

- Portland Cement, its Manufacture, Testing and Use.** By **D. B. Butler.** Third edition, 135 illus., including 17 plates, xii + 450 pp., 8vo. (1913.) 16s. net.
- Theory of Steel-Concrete Arches and of Vaulted Structures.** By **W. Cain.** Fourth edition, 27 illus., 212 pp., 18mo, boards. (*New York, 1906.*) 2s. net.
- Reinforced Concrete Construction. Elementary Course.** By **M. T. Cantell.** 65 illus., 135 pp., crown 8vo. (1911.) 4s. 6d. net.
- Reinforced Concrete Construction. Advanced Course.** By **M. T. Cantell.** 242 illus., xvi + 240 pp., super royal 8vo. (1912.) 12s. 6d. net.
- Graphical Reinforced Concrete Design.** A series of Diagrams on sheets (measuring 17½ in. by 22½ in.) for Designing and Checking. With 48-page pamphlet. By **J. A. Davenport.** Complete in roll. (1911.) 5s. net.
- Cement Users' and Buyers' Guide.** By **Calcare.** 115 pp., 32mo, cloth. (1901.) 1s. 6d. net.
- Diagrams for Designing Reinforced Concrete Structures.** By **G. F. Dodge.** 31 illus., 104 pp., oblong folio. (*New York, 1910.*) 17s. net.
- Cements, Mortars, and Concretes; their Physical properties.** By **M. S. Falk.** 78 illus., 176 pp., 8vo. (*New York, 1904.*) 10s. 6d. net.
- Concrete Construction, Methods and Cost.** By **H. P. Gillette and C. S. Hill.** 310 illus., 690 pp., 8vo. (*New York, 1908.*) £1 1s. net.

Works by A. A. HOUGHTON.

- Practical Silo Construction.** 18 illus., 69 pp., cr. 8vo. (S. & C. SERIES, No. 27.) (*New York, 1911.*) 1s. 6d. net.
- Moulding Concrete Chimneys, Slate and Roof Tiles.** 15 illus., 61 pp., cr. 8vo. (S. & C. SERIES, No. 28.) (*New York, 1911.*) 1s. 6d. net.
- Moulding and Curing Ornamental Concrete.** 5 illus., 58 pp., cr. 8vo. (S. & C. SERIES, No. 29.) (*New York, 1911.*) 1s. 6d. net.

- Concrete Wall Forms.** 16 illus., 62 pp., cr. 8vo. (S. & C. SERIES, No. 30.) (*New York, 1912.*) 1s. 6d. net.
- Concrete Monuments, Mausoleums and Burial Vaults.** 18 illus., 65 pp., cr. 8vo. (S. & C. SERIES, No. 31.) (*New York, 1911.*) 1s. 6d. net.
- Concrete Floors and Sidewalks.** 8 illus., 63 pp., cr. 8vo. (S. & C. SERIES, No. 32.) (*New York, 1911.*) 1s. 6d. net.
- Moulding Concrete Baths, Tubs, Aquariums and Natatoriums.** 16 illus., 64 pp., cr. 8vo. (S. & C. SERIES, No. 33.) (*New York, 1911.*) 1s. 6d. net.
- Concrete Bridges, Culverts, and Sewers.** 14 illus., 58 pp., cr. 8vo. (S. & C. SERIES, No. 34.) (*New York, 1912.*) 1s. 6d. net.
- Constructing Concrete Porches.** 18 illus., 62 pp., cr. 8vo. (S. & C. SERIES, No. 35.) 1s. 6d. net.
- Moulding Concrete Flower-Pots, Boxes, Jardinières, etc.** 8 illus., 52 pp., cr. 8vo. (S. & C. SERIES, No. 36.) (*New York, 1912.*) 1s. 6d. net.
- Moulding Concrete Fountains and Lawn Ornaments.** 14 illus., 56 pp., crown 8vo. (S. & C. SERIES, No. 37.) (*New York, 1912.*) 1s. 6d. net.

- Concrete and Reinforced Concrete.** By H. A. Reid. 715 illus., 884 pp., royal 8vo. (*New York, 1907.*) £1 1s. net.
- Specification for Concrete Flags.** Issued by the Institution of Municipal and County Engineers. Folio, sewed. (*1911.*) 2s. 6d. net.

CIVIL ENGINEERING

Canals, Surveying.

(See also *Irrigation and Water Supply.*)

- Practical Hints to Young Engineers Employed on Indian Railways.** By A. W. C. Addis. 14 illus., 154 pp., 12mo. (*1910.*) 3s. 6d. net.
- Levelling, Barometric, Trigonometric and Spirit.** By I. O. Baker. Third edition, 15 illus., 145 pp., 18mo, boards. (*New York, 1910.*) 2s. net.
- River and Canal Engineering.** By E. S. Bellasis. 72 illus., x + 220 pp., 8vo. (*1913.*) 8s. 6d. net.

- Punjab Rivers and Works.** By E. S. Bellasis. Second edition, 47 illus., viii + 64 pp., folio. (1912.) 8s. net.
- Notes on Instruments** best suited for Engineering Field Work in India and the Colonies. By W. G. Bligh. 65 illus., 218 pp., 8vo. (1899.) 7s. 6d.
- Practical Designing of Retaining Walls.** By Prof. W. Cain. Fifth edition, 14 illus., 172 pp., 18mo, boards. (New York, 1908.) 2s. net.
- The Civil Engineers' Cost Book.** By Major T. E. Coleman, R.E. xii + 289 pp., Pocket size ($6\frac{1}{2} \times 3\frac{5}{8}$ in.), leather cloth. (1912.) 5s. net.
- Retaining Walls in Theory and Practice.** By T. E. Coleman. 104 illus., 160 pp., crown 8vo. (1909.) 5s. net.
- On Curved Masonry Dams.** By W. B. Coventry. 8vo, sewed. (1894.) 2s.
- A Practical Method of Determining the Profile of a Masonry Dam.** By W. B. Coventry. 8vo, sewed. (1894.) 2s. 6d.
- The Stresses on Masonry Dams** (oblique sections). By W. B. Coventry. 8vo, sewed. (1894.) 2s.
- Handbook of Cost Data for Contractors and Engineers.** By H. P. Gillette. 1,854 pp., crown 8vo, leather, gilt edges. (New York, 1911.) £1 1s. net.
- High Masonry Dams.** By E. S. Gould. 2nd. edit. With illus., 88 pp., 18mo, boards. (New York, 1905.) 2s. net.
- Railway Tunnelling in Heavy Ground.** By C. Gripper. 3 plates, 66 pp., royal 8vo. (1879.) 7s. 6d.
- Levelling and its General Application.** By T. Holloway. *Third edition in preparation.*
- Waterways and Water Transport.** By J. S. Jeans. 55 illus., 520 pp., 8vo. (1890.) 9s. net.
- Table of Barometrical Heights to 20,000 Feet.** By Lieut.-Col. W. H. Mackesy. 1 plate, 24 pp., royal 32mo. (1882.) 3s.
- Aid Book to Engineering Enterprise.** By E. Matheson. Third edition, illustrated, 916 pp., medium 8vo, buckram. (1898.) £1 4s.
- A Treatise on Surveying.** By R. E. Middleton and O. Chadwick. Third edition, royal 8vo. (1911.)
 Part I. 11 plates, 162 illus., 285 pp. 10s. 6d.
 „ II. 152 illus. and 2 plates, 340 pp. 10s. 6d.

- A Pocket Book of Useful Formulæ and Memoranda**, for Civil and Mechanical Engineers. By Sir **G. L. Molesworth** and **H. B. Molesworth**. With an Electrical Supplement by **W. H. Molesworth**. Twenty-seventh edition, 800 illus., viii + 936 pp., oblong 32mo, leather. (1913.) 5s. net.
- The Pocket Books of Sir G. L. Molesworth and J. T. Hurst**, printed on India paper and bound in one vol. Royal 32mo, russia, gilt edges. 10s. 6d. net.
- Metallic Structures : Corrosion and Fouling and their Prevention**. By **J. Newman**. 38 Illus., xii + 374 pp., crown 8vo. (1896.) 9s.
- Scamping Tricks and Odd Knowledge** occasionally practised upon Public Works. By **J. Newman**. New imp., 129 pp., crown 8vo. (1908.) 2s. net.
- Compensation Discharge in the Rivers and Streams of the West Riding** (Yorkshire, England). By **M. M. Paterson**. 55 pp., 8vo. (1896.) 2s. net.
- Co-ordinate Geometry** applied to Land Surveying. By **W. Pilkington**. 5 illus., 44 pp., 12mo. (1909.) 1s. 6d. net.
- Pioneering**. By **F. Shelford**. 14 Illus., 88 pp., crown 8vo. (1909.) 3s. net.
- Topographical Surveying**. By **G. J. Specht**. Second edition, 2 plates and 28 illus., 210 pp., 18mo, boards. (*New York, 1898.*) 2s. net.
- Spons' Dictionary of Engineering**, Civil, Mechanical, Military and Naval. 10,000 illus., 4,300 pp., super royal 8vo. (1874, Supplement issued in 1881.) Complete, in 4 vols. £3 3s. net.
- Surveying and Levelling Instruments**. By **W. F. Stanley**. *Fourth edition in preparation.*
- Surveyor's Handbook**. By **T. U. Taylor**. 116 illus., 310 pp., crown 8vo, leather, gilt edges. (*New York, 1908.*) 8s. 6d. net.
- Logarithmic Land Measurement**. By **J. Wallace**. 32 pp., royal 8vo. (1910.) 5s. net.*
- The Drainage of Fens and Low Lands** by Gravitation and Steam Power. By **W. H. Wheeler**. 8 plates, 175 pp., 8vo. (1888.) 12s. 6d.
- Stadia Surveying**, the theory of Stadia Measurements. By **A. Winslow**. Fifth edition, 148 pp., 18mo, boards. (*New York 1902.*) 2s. net.

Handbook on Tacheometrical Surveying. By C. Xydis.
55 illus., 3 plates, 63 pp., 8vo. (1909.) 6s. net.

CURVE TABLES

Grace's Tables for Curves, with hints to young engineers.
8 figures, 43 pp., oblong 8vo. (1908.) 5s. net.

Data relating to Railway Curves and Super-elevations,
shown graphically. By J. H. Haiste. On folding card for
pocket use. 6d. net.

Tables for setting-out Railway Curves. By C. P. Hogg.
A series of cards in neat cloth case. 4s. 6d.

Tables for setting out Curves for Railways, Roads, Canals,
etc. By A. Kennedy and R. W. Hackwood. 32mo.
2s. net.

Spiral Tables. By J. G. Sullivan. 47 pp., 12mo, leather.
(*New York, 1908.*) 6s. 6d. net.

Tables for Setting out Curves from 101 to 5,000 feet radius.
By H. A. Cutler and F. J. Edge. Royal 32mo. 2s. net.

Tables of Parabolic Curves for the use of Railway Engineers,
and others. By G. T. Allen. Fcap 16mo. 4s.

Transition Curves. By W. G. Fox. Second edition, 80 pp.,
18mo, boards. (*New York.*) 2s. net.

DICTIONARIES

**Technological Dictionary in the English, Spanish, German
and French Languages.** By D. Carlos Huelin Y Arssu.
Crown 8vo.

Vol. I. ENGLISH-SPANISH-GERMAN-FRENCH. 609 pp.
(1906.) 10s. 6d. net.

Vol. II. GERMAN-ENGLISH-FRENCH-SPANISH. 720 pp.
(1908.) 10s. 6d. net.

Vol. III. FRENCH-GERMAN-SPANISH-ENGLISH. *In pre-
paration.*

Vol. IV. SPANISH-FRENCH-ENGLISH-GERMAN. 750 pp.
(1910.) 10s. 6d. net.

**Dictionary of English and Spanish Technical and Com-
mercial Terms.** By W. Jackson. 164 pp., fcap 8vo.
(1911.) 2s. 6d. net.

**English-French and French-English Dictionary of the
Motor-Car, Cycle and Boat.** By F. Lucas. 171 pp.,
crown 8vo. (1905.) 2s. net.

- Spanish-English Dictionary of Mining Terms.** By F. Lucas. 78 pp., 8vo. (1905.) 5s. net.
- English-Russian and Russian-English Engineering Dictionary.** By L. Meycliar. 100 pp., 16mo. (1909.) 2s. 6d. net.

DOMESTIC ECONOMY

- Food Adulteration and its Detection.** By J. P. Battershall. 12 plates, 328 pp., demy 8vo. (*New York, 1887.*) 15s.
- Practical Hints on Taking a House.** By H. P. Boulnois. 71 pp., 18mo. (1885.) 1s. 6d.
- The Cooking Range, its Failings and Remedies,** By F. Dye. 52 pp., fcap. 8vo, sewed. (1888.) 6d.
- Spices and How to Know Them.** By W. M. Gibbs. With 47 plates, including 14 in colours, 179 pp., 8vo. (*New York, 1909.*) 15s. net.
- The Kitchen Boiler and Water Pipes.** By H. Grimshaw. 8vo, sewed. (1887.) 1s. net.
- Cookery and Domestic Management,** including economic and middle class Practical Cookery. By K. Mellish. 56 coloured plates and 441 illus., 987 pp., Super royal 8vo. (1901.) 16s. net.
- Spons' Household Manual.** 250 illus., 1,043 pp., demy 8vo. (1902.) 7s. 6d.
- Ditto ditto half-bound French morocco. 9s.

DRAWING

- The Ornamental Penman's, Engraver's and Sign Writer's Pocket Book of Alphabets.** By B. Alexander. New Impression. Oblong 12mo, sewed. 6d. net.
- Slide Valve Diagrams :** a French Method for their Construction. By L. Bankson. 18mo, boards. (*New York, 1892.*) 2s. net.
- A System of Easy Lettering.** By J. H. Cromwell. Twelfth edition, 39 plates, oblong 8vo. (*New York, 1912.*) 2s. 6d. net.
- Key to the Theory and Methods of Linear Perspective.** By C. W. Dymond, F.S.A. 6 plates, 32 pp., crown 8vo. (S. & C. SERIES, No. 20.) (1910.) 1s. 6d. net.

- Plane Geometrical Drawing.** By R. C. Fawdry. Illustrated, 185 pp., crown 8vo. (1901.) 3s. net.
- Twelve Plates on Projection Drawing.** By O. Gueth. Oblong 4to. (*New York, 1903.*) 3s. net.
- Hints on Architectural Draughtsmanship.** By G. W. T. Hallatt. Fourth ed., 80 pp., f8mo. (1906.) 1s. 6d. net.
- A First Course of Mechanical Drawing (Tracing).** By G. Halliday. Oblong 4to, sewed. 2s.
- A Text-Book of Graphic Statics.** By C. W. Malcolm. 155 illus., 316 pp., 8vo. (*New York, 1909.*) 12s. 6d. net.
- Drawings for Medium-sized Repetition Work.** By R. D. Spinney. 47 illus., 130 pp., 8vo. (1909.) 3s. 6d. net.
- Mathematical Drawing Instruments.** By W. F. Stanley. Seventh ed., 265 illus., 370 pp., cr. 8vo. (1900.) 5s.

EARTHWORK

- Tables for Computing the Contents of Earthwork in the Cuttings and Embankments of Railways.** By W. Macgregor. 1 plate, 59 pp., royal 8vo. 6s.
- Tables for facilitating the Calculation of Earthworks.** By D. Cunningham. 120 pp., royal 8vo. 10s. 6d.
- Grace's Earthwork Tables.** 36 double-page tables, 4to. 12s. 6d. net.
- Earthwork Slips and Subsidences on Public Works.** By J. Newman. 240 pp., crown 8vo. (1890.) 7s. 6d.

ELECTRICAL ENGINEERING

- Journal of the Institution of Electrical Engineers.** Edited by P. F. Rowell, Secretary. Issued in quarto parts. The number of parts will be from 12 to 16 annually. Annual Subscription, 46s. post free, payable in advance. Single copies, 3s. 9d. post free.
- Practical Electric Bell Fitting.** By F. C. Allsop. Tenth edition, 186 illus., including 8 folding plates, 185 pp., cr. 8vo. (1914.) 2s. 6d. net.

- Telephones** : their Construction and Fitting. By F. C. Allsop. Eighth edition, new imp., 184 illus., 222 pp., cr. 8vo. (1914.) 2s. 6d. net.
- Electric Bell Construction.** By F. C. Allsop. New imp., 177 illus., xii + 131 pp., cr. 8vo. (1914.) 2s. 6d. net.
- Induction Coils and Coil Making.** By F. C. Allsop. Second edition, new imp., 125 illus., xii + 172 pp., cr. 8vo. (1914.) 2s. 6d. net.
- Auto-Transformer Design.** By A. H. Avery. 25 illus., 60 pp., 8vo. (1909.) 3s. 6d. net.
- Principles of Electric Power** (Continuous Current) for Mechanical Engineers. By A. H. Bate. 63 illus., 204 pp., crown 8vo. (1905.) (FINSBURY TECHNICAL MANUAL.) 4s. 6d. net.
- Practical Construction of Electric Tramways.** By W. R. Bowker. 93 illus., 119 pp., 8vo. (1903.) 6s. net.
- Dynamo Lighting for Motor Cars.** By M. A. Codd. Second edition, 140 illus., vi + 107 pp., 8vo. (1914.) 2s. 6d. net.
- Design and Construction of Induction Coils.** By A. F. Collins. 155 illus., 272 pp., demy 8vo. (New York, 1909.) 12s. 6d. net.
- Plans and Specification for Wireless Telegraph Sets.** By A. F. Collins. Crown 8vo. (S. & C. SERIES, Nos. 41 and 42). (New York, 1912.) 1s. 6d. each net.
- PART I. An Experimental Set and a One to Five Miles Set. 37 illus., viii + 45 pp.
- PART II. A Five to Ten Mile Set and a Ten to Twenty Mile Set. 63 illus., viii + 72 pp.
- Switchboard Measuring Instruments** for Continuous and Polyphase Currents. By J. C. Connan. 117 illus., 150 pp., 8vo. (1908.) 5s. net.
- Electric Cables, their Construction and Cost.** By D. Coyle and F. J. O. Howe. With many diagrams and 216 tables, 466 pp., crown 8vo, leather. (1909.) 15s. net.
- Management of Electrical Machinery.** By F. B. Crocker and S. S. Wheeler. Eighth edition, 131 illus., 223 pp., crown 8vo. (New York, 1909.) 4s. 6d. net.
- Electric Lighting** : A Practical Exposition of the Art. By F. B. Crocker. Royal 8vo. (New York.)
- Vol. I. **The Generating Plant.** Sixth edition, 213 illus., 470 pp. (1904.) 12s. 6d. net.
- Vol. II. *Out of Print.*

- The Care and Management of Ignition Accumulators.**
By H. H. U. Cross. 12 illus., 74 pp., crown 8vo. (S. & C. SERIES, No. 19.) (1910.) 1s. 6d. net.
- Elements of Telephony.** By A. Crotch. 51 illus., 90 pp., crown 8vo. (S. & C. SERIES, No. 21.) (1911.) 1s. 6d. net.
- Elementary Telegraphy and Telephony.** By Arthur Crotch. New impression, 238 illus., viii + 223 pp., 8vo. (FINSBURY TECHNICAL MANUAL.) (1912.) 4s. 6d. net.
- Electricity and Magnetism in Telephone Maintenance.**
By G. W. Cummings. 45 illus., 137 pp., 8vo. (New York, 1908.) 6s. 6d. net.
- Grouping of Electric Cells.** By W. F. Dunton. 4 illus., 50 pp., fcap. 8vo. (1906.) 1s. 6d. net.
- Wireless Telegraphy for Intending Operators.** By C. K. P. Eden. 16 illus., 80 pp., cr. 8vo. (S. & C. SERIES, No. 24.) (1913.) 1s. 6d. net.
- Magnets and Electric Currents.** By Prof. J. A. Fleming. Second edition, 136 illus., 417 pp., crown 8vo. (1902.) 5s. net.
- Notes on Design of Small Dynamo.** By George Halliday. Second edition, 8 plates, 8vo. (1895.) 2s. 6d.
- Practical Alternating Currents and Power Transmission.**
By N. Harrison. 172 illus., 375 pp., crown 8vo. (New York, 1906.) 10s. 6d. net.
- Making Wireless Outfits.** By N. Harrison. 27 illus., 61 pp., crown 8vo. (S. & C. SERIES, No. 11.) (New York, 1909.) 1s. 6d. net.
- Wireless Telephone Construction.** By N. Harrison. 43 illus., 73 pp., crown 8vo. (S. & C. SERIES, No. 12.) (New York, 1909.) 1s. 6d. net.
- Testing Telegraph Cables.** By Colonel V. Hoskier. Third edition, 11 illus., viii + 75 pp., crown 8vo. (1889.) 4s. 6d.
- Long Distance Electric Power Transmission.** By R. W. Hutchinson. 136 illus., 345 pp., crown 8vo. (New York, 1907.) 12s. 6d. net.
- Theory and Practice of Electric Wiring.** By W. S. Ibbetson. 119 illus., 366 pp., crown 8vo. (1909.) 5s. net.
- Practical Electrical Engineering for Elementary Students.**
By W. S. Ibbetson. 61 illus., 155 pp., crown 8vo. (1910.) 3s. 6d. net.

Form of Model General Conditions recommended by **The Institution of Electrical Engineers** for use in connection with Electrical Contracts. *New edition in preparation.*

Telegraphy for Beginners. By **W. H. Jones.** 19 illus., 58 pp., crown 8vo. (*New York, 1910.*) 2s. net.

A Handbook of Electrical Testing. By **H. R. Kempe.** Seventh ed., 285 illus., 706 pp., 8vo. (*1908.*) 18s. net.

Electromagnets, their Design and Construction. By **A. N. Mansfield.** 36 illus., 155 pp., 18mo, boards. (*New York, 1901.*) 2s. net.

Telephone Construction, Methods and Cost. By **G. Mayer.** With Appendices on the cost of materials and labour by **J. C. Slippy.** 103 illus., 284 pp., crown 8vo. (*New York, 1908.*) 12s. 6d. net.

Practical Electricians : a Universal Handybook on Every Day Electrical Matters. Seventh edition, 126 illus., 135 pp., 8vo. (S. & C. SERIES, No. 13.) (*New York, 1902.*) 1s. 6d. net.

Wiring Houses for the Electric Light. By **N. H. Schneider.** 40 illus., 85 pp., crown 8vo. (S. & C. SERIES, No. 25.) (*New York, 1911.*) 1s. 6d. net.

Induction Coils. By **N. H. Schneider.** Second edition, 79 illus., 285 pp., crown 8vo. (*New York, 1901.*) 4s. 6d. net.

How to Install Electric Bells, Annunciators and Alarms. By **N. H. Schneider.** 59 illus., 63 pp., crown 8vo. (S. & C. SERIES, No. 2.) (*New York, 1905.*) 1s. 6d. net.

Modern Primary Batteries, their construction, use and maintenance. By **N. H. Schneider.** 54 illus., 94 pp., crown 8vo. (S. & C. SERIES, No. 1.) (*New York, 1905.*) 1s. 6d. net.

Practical Engineers' Handbook on the Care and Management of Electric Power Plants. By **N. H. Schneider.** 203 illus., 274 pp., crown 8vo. (*New York, 1906.*) 5s. net.

Electrical Circuits and Diagrams, illustrated and explained. By **N. H. Schneider.** 8vo. (S. & C. SERIES, Nos. 3 and 4.) (*New York.*)

No. 3, Part 1. Second edition. 217 illus., 72 pp. (*New York, 1914.*) 1s. 6d. net.

No. 4, Part 2. 73 pp. (*1909.*) 1s. 6d. net.

- Electrical Instruments and Testing.** By N. H. Schneider and J. Hargrave. Fourth edition, 133 illus., xxiv + 256 pp., cr. 8vo. (*New York, 1913.*) 4s. 6d. net.
- Experimenting with Induction Coils.** By N. H. Schneider. 26 illus., 73 pp., crown 8vo. (S. & C. SERIES, No. 5.) (*New York, 1906.*) 1s. 6d. net.
- Study of Electricity for Beginners.** By N. H. Schneider. 54 illus., 88 pp., crown 8vo. (S. & C. SERIES, No. 6.) (*New York, 1905.*) 1s. 6d. net.
- Wiring Houses for the Electric Light : Low Voltage Battery Systems.** 44 illus., 86 pp., crown 8vo. (S. & C. SERIES, No. 25.) (*New York, 1911.*) 1s. 6d. net.
- Low Voltage Electric Lighting with the Storage Battery.** By N. H. Schneider. 23 illus., 85 pp., crown 8vo. (S. & C. SERIES, No. 26.) (*New York, 1911.*) 1s. 6d. net.
- Dry Batteries : how to Make and Use them.** By a Dry Battery Expert. With additional notes by N. H. Schneider. 30 illus., 59 pp., crown 8vo. (S. & C. SERIES, No. 7.) (*New York, 1905.*) 1s. 6d. net.
- The Diseases of Electrical Machinery.** By E. Schulz. Edited, with a Preface, by Prof. S. P. Thompson. 42 illus., 84 pp., cr. 8vo. (*1904.*) 2s. net.
- Electricity Simplified.** By T. O. Sloane. Thirteenth edition, 29 illus., 158 pp., crown 8vo. (*New York, 1901.*) 4s. 6d. net.
- How to become a Successful Electrician.** By T. O. Sloane. Fifteenth edition, 4 illus., 202 pp., crown 8vo. (*New York, 1906.*) 4s. 6d. net.
- Electricity : its Theory, Sources and Applications.** By J. T. Sprague. Third edition, 109 illus., 658 pp., crown 8vo. (*1892.*) 7s. 6d. net.
- Telegraphic Connections.** By C. Thom and W. H. Jones. 20 plates, 59 pp., oblong 8vo. (*New York, 1892.*) 3s. 6d. net.
- Dynamo Electric Machinery.** By Prof. S. P. Thompson. Seventh edition, demy 8vo. (FINSBURY TECHNICAL MANUAL.)
- Vol. I. CONTINUOUS-CURRENT MACHINERY. With 4 coloured and 30 folding plates, 573 illus., 984 pp. (*1904.*) £1 10s. net.
- Vol. II. ALTERNATING CURRENT MACHINERY. 15 coloured and 24 folding plates, 546 illus., 900 pp. (*1905.*) £1 10s. net.

- Design of Dynamos** (Continuous Currents). By Prof. S. P. Thompson. 4 coloured and 8 folding plates, 243 pp., demy 8vo. (1903.) 12s. net.
- Schedule for Dynamo Design**, issued with the above. 6d. each, 4s. per doz., or 18s. per 100, net.
- Curves of Magnetic Data for Various Materials.** A reprint on transparent paper for office use of Plate I from Dynamo Electric Machinery, and measuring 25 in. by 16 in. 7d. net.
- Electrical Tables and Memoranda.** By Prof. S. P. Thompson. Second ed., 15 illus. viii. + 136 pp., oblong 64mo (waistcoat-pocket size), leather. (1913.) 1s. net.
Do., do., in celluloid case. 1s. 6d. net.
- The Electromagnet.** By C. R. Underhill. 67 illus., 159 pp., crown 8vo. (New York, 1903.) 6s. 6d. net.
- Practical Guide to the Testing of Insulated Wires and Cables.** By H. L. Webb. Fifth edition, 38 illus., 118 pp., crown 8vo. (New York, 1902.) 4s. 6d. net.
- Wiring Rules.** With Extracts from the Board of Trade Regulations and the Home Office Regulations for Factories and Workshops. Issued by **The Institution of Electrical Engineers.** Sixth edition, 42 pp., 8vo, sewed. (1911.) 6d. net.

FOREIGN EXCHANGE

- English Prices with Russian Equivalents** (at Fourteen Rates of Exchange). English prices per lb., with equivalents in roubles and kopecks per pood. By A. Adiassewich. 182 pp., fcap. 32mo. 1s. net.
- English Prices with German Equivalents** (at Seven Rates of Exchange). English Prices per lb., with equivalents in marks per kilogramme. By St. Koczorowski. 95 pp., fcap. 32mo. 1s. net.
- English Prices with Spanish Equivalents.** At Seven Rates of Exchange. English prices per lb., with equivalents in pesetas per kilogramme. By S. Lambert. 95 pp., 32mo. 1s. net.
- English Prices with French Equivalents** (at Seven Rates of Exchange). English prices per lb. to francs per kilogramme. By H. P. McCartney. 97 pp., 32mo. 1s. net.
- Principles of Foreign Exchange.** By E. Matheson. Fourth edition, 54 pp., 8vo, sewed. (1905.) 3d. net.

GAS AND OIL ENGINES

- The Theory of the Gas Engine.** By D. Clerk. Edited by F. E. Idell. Third edition, 19 illus., 180 pp., 18mo, boards. (*New York, 1903.*) 2s. net.
- Electrical Ignition for Internal Combustion Engines.** By M. A. Codd. 109 illus., 163 pp., crown 8vo. (*1911.*) 3s. net.
- The Design and Construction of Oil Engines.** By A. H. Goldingham. Third edition, 112 illus., 260 pp., crown 8vo. (*New York, 1910.*) 10s. 6d. net.
- Gas Engine in Principle and Practice.** By A. H. Goldingham. New impression, 107 illus., 195 pp., 8vo. (*New York, 1912.*) 6s. 6d. net.
- Practical Handbook on the Care and Management of Gas Engines.** By G. Lieckfeld. Third edition, square 16mo. (*New York, 1896.*) 3s. 6d.
- Elements of Gas Engine Design.** By S. A. Moss. 197 pp., 18mo, boards. (*New York, 1907.*) 2s. net.
- Gas and Petroleum Engines.** A Manual for Students and Engineers. By Prof. W. Robinson. (FINSBURY TECHNICAL MANUAL.) *Third edition in preparation.*

GAS LIGHTING

- Transactions of the Institution of Gas Engineers.** Edited by Walter T. Dunn, *Secretary*. Published annually. 8vo. 10s. 6d. net.
- Gas Analyst's Manual.** By J. Abady. 102 illus., 576 pp., demy 8vo. (*1902.*) 18s. net.
- Gas Works:** their Arrangement, Construction, Plant and Machinery. By F. Colyer. 31 folding plates, 134 pp., 8vo. (*1884.*) 8s. 6d. net.
- Lighting by Acetylene.** By F. Dye. 75 illus., 200 pp., crown 8vo. (*1902.*) 6s. net.
- A Comparison of the English and French Methods of Ascertaining the Illuminating Power of Coal Gas.** By A. J. Van Eijndhoven. Illustrated, crown 8vo. (*1897.*) 4s.
- Gas Lighting and Gas Fitting.** By W. P. Gerhard. Third edition, 190 pp., 18mo, boards. (*New York, 1904.*) 2s. net.
- A Treatise on the Comparative Commercial Values of Gas Coals and Cannels.** By D. A. Graham. 3 plates, 100 pp., 8vo. (*1882.*) 4s. 6d.

The Gas Engineer's Laboratory Handbook. By **J. Hornby.** Third edition, revised, 70 illus., 330 pp., crown 8vo. (1911.) 6s. net.

Electric Gas Lighting. By **N. H. Schneider.** 57 illus., 101 pp., crown 8vo. (S. & C. SERIES, No. 8.) (*New York, 1901.*) 1s. 6d. net.

HISTORICAL AND BIOGRAPHICAL

Extracts from the Private Letters of the late Sir William Fothergill Cooke, 1836-9, relating to the Invention and Development of the Electric Telegraph; also a Memoir by **Latimer Clark.** Edited by **F. H. Webb,** Sec.Inst.E.E. 8vo. (1895.) 3s.

A Chronology of Inland Navigation in Great Britain. By **H. R. De Salis.** Crown 8vo. (1897.) 4s. 6d.

A History of Electric Telegraphy to the year 1837. By **J. J. Fahie.** 35 illus., 542 pp., crown 8vo. (1889.) 2s. net.

Life as an Engineer: its Lights, Shades, and Prospects. By **J. W. C. Haldane.** New edition, 23 plates, 390 pp., crown 8vo. (1910.) 5s. net.

A Cornish Giant. Richard Trevethick, the father of the Locomotive Engine. By **E. K. Harper.** 12 illus., including 2 plates, 60 pp., 8vo, sewed. (1913.) 1s. net.

Philipp Reis, Inventor of the Telephone: a Biographical Sketch. By **Prof. S. P. Thompson.** 8vo, cloth. (1883.) 7s. 6d.

The Development of the Mercurial Air Pump. By **Prof. S. P. Thompson.** 43 illus., 37 pp., royal 8vo, sewed. (1888.) 1s. 6d.

HOROLOGY

Watch and Clock Maker's Handbook, Dictionary and Guide. By **F. J. Britten.** Tenth edition, 450 illus., 492 pp., crown 8vo. (1902.) 5s. net.

The Springing and Adjusting of Watches. By **F. J. Britten.** 75 illus., 152 pp., crown 8vo. (1898.) 3s. net.

Prize Essay on the Balance Spring and its Isochronal Adjustments. By **M. Immisch.** 7 illus., 50 pp., crown 8vo. (1872.) 2s. 6d.

HYDRAULICS AND HYDRAULIC MACHINERY

(See also *Irrigation and Water Supply*.)

- The Suction Caused by Ships** explained in popular language. By **E. S. Bellasis**. 2 plates, 26 pp., 8vo, sewed. (1912.) 1s. net.
- Hydraulics with Working Tables**. By **E. S. Bellasis**. Second edition, 160 illus., xii+311 pp., 8vo. (1911.) 12s. net.
- Pumps** : Historically, Theoretically and Practically Considered. By **P. R. Björling**. Second edition, 156 illus., 234 pp., crown 8vo. (1895.) 7s. 6d.
- Pump [Details]**. By **P. R. Björling**. 278 illus., 211 pp., crown 8vo. (1892.) 7s. 6d.
- Pumps and Pump Motors** : A Manual for the use of Hydraulic Engineers. By **P. R. Björling**. Two vols., 261 plates, 369 pp., royal 4to. (1895.) £1 10s. net.
- Practical Handbook on Pump Construction**. By **P. R. Björling**. Second ed., new imp., 9 plates, viii + 86 pp., cr. 8vo. (1912.) 3s. 6d. net.
- Water or Hydraulic Motors**. By **P. R. Björling**. 206 illus., 287 pp., crown 8vo. (1903.) 9s.
- Hydraulic Machinery**, with an Introduction to Hydraulics. By **R. G. Blaine**. Third edition, 307 illus., 468 pp., 8vo. (FINSBURY TECHNICAL MANUAL.) (1913.) 10s. 6d. net.
- Practical Hydraulics**. By **T. Box**. Fifteenth edition, 8 plates, 88 pp., crown 8vo. (1909.) 5s. net.
- Pumping and Water Power**. By **F. A. Bradley**. 51 illus., vii + 118 pp., demy 8vo. (1912.) 4s. 6d. net.
- Hydraulic, Steam, and Hand Power Lifting and Pressing Machinery**. By **F. Colyer**. Second edition, 88 plates, 211 pp., imperial 8vo. (1892.) 10s. 6d. net.
- Pumps and Pumping Machinery**. By **F. Colyer**.
Vol. I. Second edition, 53 plates, 212 pp., 8vo. (1892.) 10s. 6d. net.
Vol. II. Second edition, 48 plates, 169 pp., 8vo. (1900.) 10s. 6d. net.
- Construction of Horizontal and Vertical Water-wheels**. By **W. Cullen**. Second edition, 12 plates, 4to. (1871.) 5s.

- Donaldson's Poncelet Turbine and Water Pressure Engine and Pump.** By **W. Donaldson.** 2 plates, viii + 32 pp., demy 4to. (1883.) 5s.
- Principles of Construction and Efficiency of Water-wheels.** By **W. Donaldson.** 13 illus., 94 pp., 8vo. (1876.) 5s.
- Practical Hydrostatics and Hydrostatic Formulæ.** By **E. S. Gould.** 27 illus., 114 pp., 18mo, boards. (New York, 1903.) 2s. net.
- Hydraulic and Other Tables** for purposes of Sewerage and Water Supply. By **T. Hennell.** Third edition, 70 pp., crown 8vo. (1908.) 4s. 6d. net.
- Tables for Calculating the Discharge of Water in Pipes for Water and Power Supplies.** Indexed at side for ready reference. By **A. E. Silk.** 63 pp., crown 8vo. (1899.) 5s.
- Simple Hydraulic Formulæ.** By **T. W. Stone.** 9 plates, 98 pp., crown 8vo. (1881.) 4s.
- A B C of Hydrodynamics.** By **Lieut.-Col. R. de Villamil.** 48 illus., xi + 135 pp., demy 8vo. (1912.) 6s. net.

INDUSTRIAL CHEMISTRY AND MANUFACTURES

- Transactions of the American Institute of Chemical Engineers.** Issued annually. 30s. net.
- Perfumes and their Preparation.** By **G. W. Askinson.** Translated by **I. Fuest.** Third ed., 32 illus., 312 pp., 8vo. (New York, 1907.) 12s. 6d. net.
- Brewing Calculations, Gauging and Tabulation.** By **C. H. Bater.** 340 pp., 64mo, roan, gilt edges. (1897.) 1s. 6d. net.
- A Pocket Book for Chemists, Chemical Manufacturers, Metallurgists, Dyers, Distillers, etc.** By **T. Bayley.** Seventh edition, new impression, 550 pp., royal 32mo, roan, gilt edges. (1912.) 5s. net.
- Practical Receipts for the Manufacturer, the Mechanic, and for Home use.** By **Dr. H. R. Berkeley** and **W. M. Walker.** New impression, 250 pp., demy 8vo. (1912.) 5s. net.
- A Treatise on the Manufacture of Soap and Candles, Lubricants and Glycerine.** By **W. L. Carpenter** and **H. Leask.** Second edition, 104 illus., 456 pp., crown 8vo. (1895.) 12s. 6d.

- A Text Book of Paper Making.** By C. F. Cross and E. J. Bevan. Third edition, 97 illus., 411 pp., crown 8vo. (1907.) 12s. 6d. net.
- C.B.S. Standard Units and Standard Paper Tests.** By C. F. Cross, E. J. Bevan, C. Beadle and R. W. Sindall. 25 pp., crown 4to. (1903.) 2s. 6d. net.
- Pyrometry.** By C. R. Darling. 60 illus., 200 pp., crown 8vo. (1911.) 5s. net.
- Soda Fountain Requisites.** A Practical Receipt Book for Druggists, Chemists, etc. By G. H. Dubelle. Third edition, 157 pp., crown 8vo. (New York, 1905.) 4s. 6d. net.
- Spices and How to Know Them.** By W. M. Gibbs. 47 plates, including 14 in colours, 176 pp., 8vo. (New York, 1909.) 15s. net.
- The Chemistry of Fire and Fire Prevention.** By H. and H. Ingle. 45 illus., 290 pp., crown 8vo. (1900.) 9s.
- Ice-making Machines.** By M. Ledoux and others. Sixth edition, 190 pp., 18mo, boards. (New York, 1906.) 2s. net.
- Brewing with Raw Grain.** By T. W. Lovibond. 75 pp., crown 8vo. (1883.) 5s.
- The Chemistry, Properties, and Tests of Precious Stones.** By J. Mastin. 114 pp., fcap. 16mo, limp leather, gilt top. (1911.) 2s. 6d. net.
- Sugar, a Handbook for Planters and Refiners.** By the late J. A. R. Newlands and B. E. R. Newlands. 236 illus., 876 pp., 8vo. (1909.) £1 5s. net.
- Principles of Leather Manufacture.** By Prof. H. R. Procter. *Second edition in preparation.*
- Leather Industries Laboratory Handbook of Analytical and Experimental Methods.** By H. R. Procter. Second edition, 4 plates, 46 illus., 450 pp.; 8vo. (1908.) 18s. net.
- Leather Chemists' Pocket Book.** A short compendium of Analytical Methods. By Prof. H. R. Procter. Assisted by Dr. E. Stiasny and H. Brumwell. 4 illus., xiv + 223 pp., 16mo, leather. (1912.) 5s. net.
- Theoretical and Practical Ammonia Refrigeration.** By I. I. Redwood. Sixth thousand, 15 illus., 146 pp., square 16mo. (New York, 1909.) 4s. 6d. net.
- Breweries and Maltings.** By G. Scammell and F. Colyer. Second edition, 20 plates, 178 pp., 8vo. (1880.) 6s. net.

Factory Glazes for Ceramic Engineers. By H. Rumbellow. Folio. Series A, Leadless Sanitary Glazes. (1908.) £2 2s. net.

Spons' Encyclopædia of the Industrial Arts, Manufactures and Commercial Products. 2 vols. 1,500 illus., 2,100 pp., super royal 8vo. (1882.) £2 2s. net.

Refrigeration and Ice-making and Refrigerating Machinery. By W. H. Wakeman. 4th ed., 15 illus., 43 pp., 8vo, sewed. (New York, 1909.) 1s. 6d. net.

Tables for the Quantitative Estimation of the Sugars. By E. Wein and W. Frew. Crown 8vo. (1896.) 6s.

Handbook of Natural Gas. By Henry P. Westcott, with Tables by F. H. Oliphant. 156 illus., 529 pp. 8vo. (New York, 1913.) 17s. net.

The Puering, Bating and Drenching of Skins. By J. T. Wood. 33 illus., xv + 300 pp., 8vo. (1912.) 12s. 6d. net.

Workshop Receipts. For the use of Manufacturers, Mechanics and Scientific Amateurs. NEW AND THOROUGHLY REVISED EDITION, crown 8vo. (1909.) 3s. each net.

Vol. I. ACETYLENE LIGHTING to DRYING. 223 illus., 532 pp.

Vol. II. DYEING to JAPANING. 259 illus., 540 pp.

Vol. III. JOINTING PIPES to PUMPS. 256 illus., 528 pp.

Vol. IV. RAINWATER SEPARATORS to WIRE ROPE SPLICING. 321 illus., 540 pp.

Practical Handbook on the Distillation of Alcohol from Farm Products. By F. B. Wright. Second edition, 60 illus., 271 pp., crown 8vo. (New York, 1907.) 4s. 6d. net.

The Manufacture of Chocolate and other Cacao Preparations. By P. Zipperer. Second edition, 87 illus., 280 pp., royal 8vo. (1902.) 16s. net.

INTEREST TABLES

The Wide Range Dividend and Interest Calculator, showing at a glance the Percentage on any sum from One Pound to Ten Thousand Pounds, at any Interest, from 1 per cent. to 12½ per cent., proceeding by ¼ per cent. By A. Stevens. 100 pp., super royal 8vo. 6s. net.

Quarter morocco, cloth sides, 7s. 6d. net.

The Wide Range Income Tax Calculator, showing at a glance the Tax on any sum from One Shilling to Thousand Pounds, at the Rate of 9d., 1s., and 1s. 2d. in the Pound. By A. Stevens. On folding card, imperial 8vo. 1s. net.

IRRIGATION

- Irrigation Works.** By E. S. Bellasis. 37 illus., viii + 174 pp., 8vo. (1913.) 8s. net.
- Punjab Rivers and Works.** By E. S. Bellasis. Second edition, 47 illus., 65 pp., folio. (1912.) 8s. net.
- Irrigation Pocket Book.** By R. B. Buckley. Second ed., 80 illus., viii + 475 pp., cr. 8vo, leather, gilt edges. (1913.) 15s. net.
- The Design of Channels for Irrigation and Drainage.** By R. B. Buckley. 22 diagrams, 56 pp., crown 8vo. (1911.) 2s. net.
- The Irrigation Works of India.** By R. B. Buckley. Second edition, with coloured maps and plans. 336 pp., 4to, cloth. (1905.) £2 2s. net.
- Irrigated India.** By Hon. Alfred Deakin. With Map, 322 pp., 8vo. (1893.) 8s. 6d.
- Indian Storage Reservoirs, with Earthen Dams.** By W. L. Strange. Second ed., 16 plates, 59 illus., xxiv + 442 pp., 8vo. (1913.) 21s. net.
- The Irrigation of Mesopotamia.** By Sir W. Willcocks. 2 vols., 46 plates, 136 pp. (Text super royal 8vo, plates folio.) (1911.) £1 net.
- Egyptian Irrigation.** By Sir W. Willcocks and J. I. Craig. In 2 Vols. Third edition, 81 plates, 183 illus., 900 pp., sup. roy. 8vo. (1913.) 42s. net.
- The Nile Reservoir Dam at Assuân, and After.** By Sir W. Willcocks. Second edition, 13 plates, 35 pp., super royal 8vo. (1903.) 3s. net.
- The Assuân Reservoir and Lake Moeris.** By Sir W. Willcocks. With text in English, French and Arabic. 5 plates, 116 pp., super royal 8vo. (1904.) 3s. net.
- The Nile in 1904.** By Sir W. Willcocks. 30 plates, 200 pp., super royal 8vo. (1904.) 5s. net.

LOGARITHM TABLES

- Aldum's Pocket Folding Mathematical Tables.** Four-figure Logarithms, and Anti-logarithms, Natural Sines, Tangents, Cotangents, Cosines, Chords and Radians for all angles from 1 to 90 degrees. And Decimalizer Table for Weights and Money. On folding card. 4d. net. 20 copies, 6s. net.

Tables of Seven-figure Logarithms of the Natural Numbers from 1 to 108,000. By **C. Babbage**. Stereotype edition, 224 pp., medium 8vo. 5s. net.

Four-Place Tables of Logarithms and Trigonometric Functions. By **E. V. Huntington**. Ninth thousand, 34 pp., square 8vo, limp buckram, with cut lateral index. (*New York, 1911.*) 3s. net.

Short Logarithmic and other Tables. By **W. C. Unwin**. Fourth edition, small 4to. 3s.

Logarithmic Land Measurement. By **J. Wallace**. 32 pp., royal 8vo. (*1910.*) 5s. net.

A B C Five-figure Logarithms with Tables, for Chemists. By **C. J. Woodward**. Crown 8vo. 2s. 6d. net.

A B C Five-figure Logarithms for general use, with lateral index for ready reference. By **C. J. Woodward**. Second edition, with cut lateral Index, 116 pp., 12mo, limp leather. 3s. net.

MARINE ENGINEERING AND NAVAL ARCHITECTURE

Marine Propellers. By **S. W. Barnaby**. Fifth edition, 5 plates, 56 illus., 185 pp., demy 8vo. (*1908.*) 10s. 6d. net.

Marine Engineer's Record Book: Engines. By **B. C. Bartley**. 8vo, roan. 5s. net.

The Suction Caused by Ships and the Olympic-Hawke Collision. By **E. S. Bellasis**. 1 chart and 5 illus. in text, 26 pp., 8vo, sewed. (*1912.*) 1s. net.

Yachting Hints, Tables and Memoranda. By **A. C. Franklin**. Waistcoat pocket size, 103 pp., 64mo, roan, gilt edges. 1s. net.

Steamship Coefficients, Speeds and Powers. By **C. F. A. Fyfe**. 31 plates, 280 pp., fcap. 8vo, leather. (*1907.*) 10s. 6d. net.

How to Build a Speed Launch. By **E. W. Graef**. 14 plates, 32 pp., quarto. (*New York, 1903.*) 4s. 6d. net.

Steamships and Their Machinery, from first to last. By **J. W. C. Haldane**. 120 illus., 532 pp., 8vo. (*1893.*) 15s.

Tables for Constructing Ships' Lines. By **A. Hogg**. Third edition, 3 plates, 20 pp., 8vo, sewed. (*1911.*) 3s. net.

- Tabulated Weights** of Angle, Tee, Bulb, Round, Square, and Flat Iron and Steel for the use of Naval Architects, Shipbuilders, etc. By **C. H. Jordan**. Sixth edition, 640 pp., royal 32mo, leather, gilt edges. (1909.) 7s. 6d. net.
- Particulars of Dry Docks, Wet Docks, Wharves, etc.,** on the River Thames. Compiled by **C. H. Jordan**. Second edition, 7 coloured charts, 103 pp., oblong 8vo. (1904.) 2s. 6d. net.
- Marine Transport of Petroleum.** By **H. Little**. 66 illus., 263 pp., crown 8vo. (1890.) 10s. 6d.
- Questions and Answers for Marine Engineers,** with a Practical Treatise on Breakdowns at Sea. By **T. Lucas**. 12 folding plates, 515 pp., gilt edges, crown 8vo. (*New York, 1902.*) 8s. net.
- How to Build a Motor Launch.** By **C. D. Mower**. 49 illus., 42 pp., 4to. (*New York, 1904.*) 4s. 6d. net.
- Reed's Engineers' Handbook to the Board of Trade Examinations** for certificates of Competency as First and Second Class Engineers. Nineteenth edition, 37 plates, 358 illus., 696 pp., 8vo. 14s. net.
- Key to Reed's Handbook.** 7s. 6d. net.
- Reed's Marine Boilers.** Third edition, 79 illus., 258 pp., crown 8vo. (1905.) 4s. 6d. net.
- Reed's Useful Hints to Sea-going Engineers.** Fourth edition, 8 plates, 50 illus., 312 pp., crown 8vo. (1903.) 3s. 6d. net.
- How to Build a Three-horse Power Launch Engine.** By **E. W. Roberts**. 14 plates, 66 pp., folio. (*New York, 1901.*) 10s. 6d. net.

MATERIALS

- Practical Treatise on the Strength of Materials.** By **T. Box**. Fourth edition, 27 plates, 536 pp., 8vo. (1902.) 12s. 6d. net.
- Solid Bitumens.** By **S. F. Peckham**. 23 illus., 324 pp., 8vo. (*New York, 1909.*) £1 1s. net.
- Lubricants, Oils and Greases.** By **I. I. Redwood**. 3 plates, ix + 54 pp., 8vo. (1898.) 6s. 6d. net.
- Practical Treatise on Mineral Oils and their By-Products.** By **I. I. Redwood**. 76 illus., 336 pp., 8vo. (1897.) 15s.

- Silico-Calcareous Sandstones**, or Building Stones from Quartz, Sand and Lime. By **E. Stoffler**. 5 plates, 8vo, sewed. (1901.) 4s. net.
- Proceedings of the Fifth Congress, International Association for Testing Materials**. English edition. 189 illus., 549 pp., 8vo. (1910.) 18s. net.
- Proceedings of the Sixth Congress**. (1913.) 30s. net.

MATHEMATICS

- Imaginary Quantities**. By **M. Argand**. Translated by Prof. **Hardy**. 18mo, boards. (*New York*.) 2s. net.
- Text-book of Practical Solid Geometry**. By **E. H. de V. Atkinson**. Revised by Major **B. R. Ward**, R.E. Second edition, 17 plates, 134 pp., 8vo. (1913.) 7s. 6d.
- Quick and Easy Methods of Calculating**, and the Theory and Use of the Slide Rule. By **R. G. Blaine**. Fourth edition, 6 illus., xii + 152 pp., 16mo. (1912.) 2s. 6d. net.
- Symbolic Algebra**, or the Algebra of Algebraic Numbers. By **W. Cain**. 12 illus., 131 pp., 18mo, boards. (*New York*, 1884.) 2s. net.
- Nautical Astronomy**. By **J. H. Colvin**. 127 pp., crown 8vo. (1901.) 2s. 6d. net.
- Chemical Problems**. By **J. C. Foye**. Fourth edition, 141 pp., 18mo, boards. (*New York*, 1898.) 2s. net.
- Primer of the Calculus**. By **E. S. Gould**. Second edition, 24 illus., 122 pp., 18mo, boards. (*New York*, 1899.) 2s. net.
- Elementary Treatise on the Calculus** for Engineering Students. By **J. Graham**. Fourth edition, 116 illus., xii + 355 pp., cr. 8vo. (1914.) 5s. net.
- Manual of the Slide Rule**. By **F. A. Halsey**. Second edition, 31 illus., 84 pp., 18mo, boards. (*New York*, 1901.) 2s. net.
- Reform in Chemical and Physical Calculations**. By **C. J. T. Hanssen**. 4to. (1897.) 6s. 6d. net.
- Algebra Self-Taught**. By **P. Higgs**. Third edition, 104 pp., crown 8vo. (1903.) 2s. 6d.
- A Text-book on Graphic Statics**. By **C. W. Malcolm**. 155 illus., 316 pp., 8vo. (*New York*, 1909.) 12s. 6d. net.
- Galvanic Circuit Investigated Mathematically**. By **G. S. Ohm**. Translated by **William Francis**. 269 pp., 18mo, boards. (*New York*, 1891.) 2s. net.

- Elementary Practical Mathematics.** By M. T. Ormsby. Second edition, 128 illus., xii + 410 pp., medium 8vo. (1911.) 5s. net.
- Elements of Graphic Statics.** By K. Von Ott. Translated by G. S. Clarke. 95 illus., 128 pp., crown 8vo. (1901.) 5s.
- Figure of the Earth.** By F. C. Roberts. 2 illus., 95 pp., 18mo, boards. (New York, 1885.) 2s. net.
- Arithmetic of Electricity.** By T. O'C. Sloane. Thirteenth edition, 5 illus., 162 pp., crown 8vo. (New York, 1901.) 4s. 6d. net.
- Graphic Method for Solving certain Questions in Arithmetic or Algebra.** By G. L. Vose. Second edition, 28 illus., 62 pp., 18mo, boards. (New York, 1902.) 2s. net.
- Problems in Electricity.** A Graduated Collection comprising all branches of Electrical Science. By R. Weber. Translated from the French by E. A. O'Keefe. 34 illus., 366 pp., crown 8vo. (1902.) 7s. 6d. net.

MECHANICAL ENGINEERING

Steam Engines and Boilers, etc.

- Engineers' Sketch Book of Mechanical Movements.** By T. W. Barber. Fifth edition, 3,000 illus., 355 pp., 8vo. (1906.) 10s. 6d. net.
- The Repair and Maintenance of Machinery.** By T. W. Barber. 417 illus., 476 pp., 8vo. (1895.) 10s. 6d.
- The Science of Burning Liquid Fuel.** By William Newton Best. 100 illus., 159 pp., 8vo. (1913.) 9s. net.
- Practical Treatise on Mill Gearing.** By T. Box. Fifth edition, 11 plates, 128 pp., crown 8vo. (1892.) 7s. 6d.
- The Mechanical Engineers' Price Book.** Edited by G. Brooks. 176 pp., pocket size ($6\frac{1}{2}$ in. by $3\frac{3}{4}$ in. by $\frac{1}{2}$ in. thick), red leather cloth. 4s. net.
- Safety Valves.** By R. H. Buell. Third edition, 20 illus., 100 pp., 18mo, boards. (New York, 1898.) 2s. net.
- Machine Design.** By Prof. W. L. Cathcart.
Part I. FASTENINGS. 123 illus., 291 pp., demy 8vo. (New York, 1903.) 12s. 6d. net.
- Chimney Design and Theory.** By W. W. Christie. Second edition, 54 illus., 192 pp., crown 8vo. (New York, 1902.) 12s. 6d. net.

- Furnace Draft** : its Production by Mechanical Methods. By **W. W. Christie**. 5 illus., 80 pp., 18mo, boards. (*New York, 1906.*) 2s. net.
- The Stokers' Catechism**. By **W. J. Connor**. 63 pp., limp. (*1906.*) 1s. net.
- Treatise on the use of Belting** for the Transmission of Power. By **J. H. Cooper**. Fifth edition, 94 illus., 399 pp., demy 8vo. (*New York, 1901.*) 12s. 6d. net.
- The Steam Engine considered as a Thermo-dynamic Machine**. By **J. H. Cotterill**. Third edition, 39 diagrams, 444 pp., 8vo. (*1896.*) 15s.
- Fireman's Guide**, a Handbook on the Care of Boilers. By **K. P. Dahlstrom**. Eleventh edition, fcap. 8vo. (S. & C. SERIES, No. 16.) (*New York, 1906.*) 1s. 6d. net.
- Heat for Engineers**. By **C. R. Darling**. Second edition, 110 illus., 430 pp., 8vo. (FINSBURY TECHNICAL MANUAL.) (*1912.*) 12s. 6d. net.
- Belt Driving**. By **G. Halliday**. 3 folding plates, 100 pp., 8vo. (*1894.*) 3s. 6d.
- Worm and Spiral Gearing**. By **F. A. Halsey**. 13 plates, 85 pp., 18mo, boards. (*New York, 1903.*) 2s. net.
- Commercial Efficiency of Steam Boilers**. By **A. Hanssen**. Large 8vo, sewed. (*1898.*) 6d.
- Corliss Engine**. By **J. T. Henthorn**. Third edition, 23 illus., 95 pp., crown 8vo. (S. & C. SERIES, No. 23.) (*New York, 1910.*) 1s. 6d. net.
- Liquid Fuel** for Mechanical and Industrial Purposes. By **E. A. Brayley Hodgetts**. 106 illus., 129 pp., 8vo. (*1890.*) 5s.
- Elementary Text-book on Steam Engines and Boilers**. By **J. H. Kinealy**. Fourth edition, 106 illus., 259 pp., 8vo. (*New York, 1903.*) 8s. 6d. net.
- Centrifugal Fans**. By **J. H. Kinealy**. 33 illus., 206 pp., fcap. 8vo, leather. (*New York, 1905.*) 12s. 6d. net.
- Mechanical Draft**. By **J. H. Kinealy**. 27 original tables and 13 plates, 142 pp., crown 8vo. (*New York, 1906.*) 8s. 6d. net.
- The A B C of the Steam Engine**, with a description of the Automatic Governor. By **J. P. Lisk**. 6 plates, 8vo. (S. & C. SERIES, No. 17.) (*New York, 1910.*) 1s. 6d. net.

- Valve Setting Record Book.** By **P. A. Low.** 8vo, boards.
1s. 6d.
- The Lay-out of Corliss Valve Gears.** By **S. A. Moss.**
Second edition, 3 plates, 108 pp., 18mo, boards. (*New York, 1906.*) 2s. net.
- Steam Boilers, their Management and Working.** By **J. Peattie.** Fifth edition, 35 illus., 230 pp., crown 8vo.
(1906.) 4s. 6d. net.
- Treatise on the Richards Steam Engine Indicator.** By
C. T. Porter. Sixth edition, 3 plates and 73 diagrams,
285 pp., 8vo. (1902.) 9s.
- Practical Treatise on the Steam Engine.** By **A. Rigg.**
Second edition, 103 plates, 378 pp., demy 4to. (1894.)
£1 5s.
- Power and its Transmission.** A Practical Handbook for
the Factory and Works Manager. By **T. A. Smith.**
76 pp., fcap. 8vo. (1910.) 2s. net.
- Slide Valve Simply Explained.** By **W. J. Tennant.** Re-
vised by **J. H. Kinealy.** 41 illus., 83 pp., crown 8vo. (*New York, 1899.*) 4s. 6d. net.
- Shaft Governors.** By **W. Trinks** and **C. Hoosum.** 27 illus.,
97 pp., 18mo, boards. (*New York, 1905.*) 2s. net.
- Treatise on the Design and Construction of Mill Buildings.**
By **H. G. Tyrrell.** 652 illus., 490 pp., 8vo. (*New York, 1911.*) 17s. net.
- Slide and Piston Valve Geared Steam Engines.** By **W. H. Uhlund.** 47 plates and 314 illus., 155 pp. Two vols.,
folio, half morocco. (1882.) £1 16s.
- How to run Engines and Boilers.** By **E. P. Watson.** Fifth
edition, 31 illus., 160 pp., 8vo. (*New York, 1904.*) 3s. 6d.
- Position Diagram of Cylinder with Meyer Cut-off.** By
W. H. Weightman. On card. (*New York.*) 1s. net.
- Practical Method of Designing Slide Valve Gearing.** By
E. J. Welch. 69 illus, 283 pp., crown 8vo. (1890.) 6s.
- Elements of Mechanics.** By **T. W. Wright.** Eighth edition,
215 illus., 382 pp., 8vo. (*New York, 1909.*) 10s. 6d. net.

METALLURGY

Iron and Steel Manufacture

- Life of Railway Axles.** By T. Andrews. 8vo, sewed. (1895.) 1s.
- Microscopic Internal Flaws in Steel Rails and Propeller Shafts.** By T. Andrews. 8vo, sewed. (1896.) 1s.
- Microscopic Internal Flaws, Inducing Fracture in Steel.** By T. Andrews. 8vo, sewed. (1896.) 2s.
- Practical Alloying.** A compendium of Alloys and Processes for Brassfounders, Metal Workers, and Engineers. By John F. Buchanan. 41 illus., 205 pp., 8vo. (*New York, 1911.*) 10s. 6d. net.
- Brassfounders' Alloys.** By J. F. Buchanan. 23 illus., viii + 129 pp., crown 8vo. (1905.) 4s. 6d. net.
- The Moulder's Dictionary (Foundry Nomenclature).** By J. F. Buchanan. New impression, 26 illus., viii + 225 pp., crown 8vo. (1912.) 3s. net.
- American Standard Specifications for Steel.** By A. L. Colby. Second edition, revised, 103 pp., crown 8vo. (*New York, 1902.*) 5s. net.
- Galvanized Iron: its Manufacture and Uses.** By J. Davies. 139 pp., 8vo. (1899.) 5s. net.
- Management of Steel.** By G. Ede. Seventh edition, 216 pp., crown 8vo. (1903.) 5s.
- The Frodair Handbook for Ironfounders.** 160 pp., 12mo. (1910.) 2s. net.
- Manufacture of Iron and Steel.** By H. R. Hearson. 21 illus., xii + 103 pp., 8vo. (1912.) 4s. 6d. net.
- Cupola Furnace.** By E. Kirk. Third edition, 106 illus., 484 pp., 8vo. (*New York, 1910.*) 15s. net.
- Practical Notes on Pipe Founding.** By J. W. Macfarlane. 15 plates, 148 pp., 8vo. (1888.) 12s. 6d.
- Atlas of Designs concerning Blast Furnace Practice.** By M. A. Pavloff. 127 plates, 14 in. by 10½ in. oblong, sewed. (1902.) £1 1s. net.
- Album of Drawings relating to the Manufacture of Open Hearth Steel.** By M. A. Pavloff.
- Part I. OPEN HEARTH FURNACES. 52 plates, 14 in. by 10½ in. oblong folio, in portfolio. (1904.) 12s. net.

- Metallography Applied to Siderurgic Products.** By H. Savoia. Translated by R. G. Corbet. 94 illus., 180 pp., crown 8vo. (1910.) 4s. 6d. net.
- Modern Foundry Practice.** By J. Sharp. Second edition, new impression, 272 illus., 759 pp., 8vo. (1911.) £1 1s. net.
- Roll Turning for Sections in Steel and Iron.** By A. Spencer. Second edition, 78 plates, 4to. (1894.) £1 10s.

METRIC TABLES

- French Measure and English Equivalents.** By J. Brook. Second edition, 80 pp., fcap. 32mo, roan. 1s. net.
- A Dictionary of Metric and other useful Measures.** By L. Clark. 113 pp., 8vo. (1891.) 6s.
- English Weights, with their Equivalents in kilogrammes.** By F. W. A. Logan. 96 pp., fcap. 32mo, roan. 1s. net.
- Metric Weights with English Equivalents.** By H. P. McCartney. 84 pp., fcap. 32mo, roan. 1s. net.
- Metric Tables.** By Sir G. L. Molesworth. Fourth edition, 95 pp., royal 32mo. (1909.) 2s. net.
- Metric-English and English-Metric Lengths.** By G. A. Rossetti. xii + 80 pp., ob. 32mo. 1s. net. Giving equivalents in millimetres (to five significant figures) of all English lengths from $\frac{1}{64}$ th of an inch to 10 ft., advancing by 64ths of an inch; and equivalents to the nearest 64th of an inch of all Metric lengths from 1 to 3,200 millimetres, advancing by millimetres.
- Tables for Setting out Curves** from 200 metres to 4,000 metres by tangential angles. By H. Williamson. 4 illus., 60 pp., 18mo. 2s. net.

MINERALOGY AND MINING

- Rock Blasting.** By G. G. Andre. 12 plates and 56 illus. in text, 202 pp., 8vo. (1878.) 5s.
- Winding Plants for Great Depths.** By H. C. Behr. In two parts. 8vo, sewed. (1902.) £2 2s. net.
- Practical Treatise on Hydraulic Mining in California.** By A. J. Bowie, Junr. Tenth edition, 73 illus., 313 pp., royal 8vo. (New York, 1905.) £1 1s. net.

- Tables for the Determination of Common Rocks.** By O. Bowles. 64 pp., 18mo, boards. (VAN NOSTRAND SERIES, No. 125.) (*New York, 1910.*) 2s. net.
- Manual of Assaying Gold, Silver, Copper and Lead Ores.** By W. L. Brown. Twelfth edition, 132 illus., 589 pp., crown 8vo. (*New York, 1907.*) 10s. 6d. net.
- Fire Assaying.** By E. W. Buskett. 69 illus., 105 pp., crown 8vo. (*New York, 1907.*) 4s. 6d. net.
- Tin :** Describing the Chief Methods of Mining, Dressing, etc. By A. G. Charleton. 15 plates, 83 pp., crown 8vo. (1884.) 12s. 6d.
- Gold Mining and Milling in Western Australia,** with Notes upon Telluride Treatment, Costs and Mining Practice in other Fields. By A. G. Charleton. 82 illus. and numerous plans and tables, 648 pp., super royal 8vo. (1903.) 12s. 6d. net.
- Miners' Geology and Prospectors' Guide.** By G. A. Corder. 29 plates, 224 pp., crown 8vo. (1907.) 5s. net.
- Blasting of Rock in Mines, Quarries, Tunnels, etc.** By A. W. and Z. W. Daw. Second edition, 90 illus., 316 pp., demy 8vo. (1909.) 15s. net.
- Gold Dredging.** By C. T. Earl. 17 maps, 78 illus., xvi + 208 pp., 8vo. (1913.) 20s. net.
- Handbook of Mineralogy ;** determination and description of Minerals found in the United States. By J. C. Foye. 180 pp., 18mo, boards. (*New York, 1886.*) 2s. net.
- Our Coal Resources at the End of the Nineteenth Century.** By Prof. E. Hull. 157 pp., demy 8vo. (1897.) 6s.
- Hydraulic Gold Miners' Manual.** By T. S. G. Kirkpatrick. Second edition, 12 illus., 46 pp., crown 8vo. (1897.) 4s.
- Economic Mining.** By C. G. W. Lock. 175 illus., 680 pp., 8vo. (1895.) 10s. 6d. net.
- Gold Milling : Principles and Practice.** By C. G. W. Lock. 200 illus., 850 pp., demy 8vo. (1901.) £1 1s. net.
- Mining and Ore-Dressing Machinery.** By C. G. W. Lock. 639 illus., 466 pp., super royal 4to. (1890.) £1 5s.
- Miners' Pocket Book.** By C. G. W. Lock. Fifth edition, 233 illus., 624 pp., fcap. 8vo, leather, gilt edges. (1908.) 10s. 6d. net.
- Chemistry, Properties and Tests of Precious Stones.** By J. Mastin. 114 pp., fcap. 16mo, limp leather, gilt top. (1911.) 2s. 6d. net.

- Tests for Ores, Minerals and Metals of Commercial Value.**
By **R. L. McMechen.** 152 pp., 12mo. (*New York, 1907.*)
5s. 6d. net.
- Practical Handbook for the Working Miner and Prospector,**
and the Mining Investor. By **J. A. Miller.** 34 illus.,
234 pp., crown 8vo. (*1897.*) 7s. 6d.
- Theory and Practice of Centrifugal Ventilating Machines.**
By **D. Murgue.** 7 illus., 81 pp., 8vo. (*1883.*) 5s.
- Examples of Coal Mining Plant.** By **J. Povey-Harper.**
Second edition, 40 plates, 26 in. by 20 in. (*1895.*) £4 4s. net.
- Examples of Coal Mining Plant, Second Series.** By **J.**
Povey-Harper. 10 plates, 26 in. by 20 in. (*1902.*)
£1 12s. 6d. net.

MODELS AND MODEL MAKING

- How to Build a Model Yacht.** By **H. Fisher.** 45 illus.,
50 pp., 4to. (*New York, 1902.*) 4s. 6d. net.
- Model Engines and Small Boats.** By **N. M. Hopkins.** 50
illus., viii + 74 pp., crown 8vo. (*New York, 1898.*) 5s. 6d. net.
- Theory and Practice of Model Aeroplaning.** By **V. E.**
Johnson. 61 illus., xvi + 148 pp., crown 8vo. (*1910.*)
3s. 6d. net.
- The Gyroscope, an Experimental Study.** By **V. E. John-**
son. 34 illus., 40 pp., cr. 8vo. (S. & C. SERIES, No. 22.)
(*1911.*) 1s. 6d. net.
- The Model Vaudeville Theatre.** By **N. H. Schneider.** 34
illus., 90 pp., crown 8vo. (S. & C. SERIES, No. 15.) (*New*
York, 1910.) 1s. 6d. net.
- Electric Toy-Making.** By **T. O. Sloane.** Fifteenth edition,
70 illus., 183 pp., crown 8vo. (*New York, 1903.*) 4s. 6d. net.
- Model Steam Engine Design.** By **R. M. De Vignier.** 34
illus., 94 pp., crown 8vo, limp. (S. & C. SERIES, No. 9.)
(*New York, 1907.*) 1s. 6d. net.
- Small Engines and Boilers.** By **E. P. Watson.** 33 illus.,
viii + 108 pp., crown 8vo. (*New York, 1899.*) 5s. 6d. net.

ORGANIZATION

Accounts, Contracts and Management

- Organization of Gold Mining Business**, with Specimens of the Departmental Report Books and the Account Books. By **Nicol Brown**. Second edition, 220 pp., fcap. folio. (1903.) £1 5s. net.
- Cost Keeping and Management Engineering**. A Treatise for those engaged in Engineering Construction. By **H. P. Gillette** and **R. T. Dana**. 184 illus., 346 pp., 8vo. (*New York, 1909.*) 15s. net.
- Handbook on Railway Stores Management**. By **W. O. Kempthorne**. 268 pp., demy 8vo. (1907.) 10s. 6d. net.
- Depreciation of Factories, Municipal, and Industrial Undertakings, and their Valuation**. By **E. Matheson**. Fourth edition, 230 pp., 8vo. (1910.) 10s. 6d. net.
- Aid Book to Engineering Enterprise**. By **E. Matheson**. Third edition, 916 pp., 8vo, buckram. (1898.) £1 4s.
- Office Management**. A handbook for Architects and Civil Engineers. By **W. Kaye Parry**. *New Edition in preparation.*
- Commercial Organization of Engineering Factories**. By **H. Spencer**. 92 illus., 221 pp., 8vo. (1907.) 10s. 6d. net.

PHYSICS

Colour, Heat and Experimental Science

- The Entropy Diagram and its Applications**. By **M. J. Boulvin**. 38 illus., 82 pp., demy 8vo. (1898.) 5s.
- Physical Problems and their Solution**. By **A. Bourgougnon**. 224 pp., 18mo, boards. (*New York, 1897.*) 2s. net.
- Heat for Engineers**. By **C. R. Darling**. Second edition, 110 illus., 430 pp., 8vo. (FINSBURY TECHNICAL MANUAL.) (1912.) 12s. 6d. net.
- Engineering Thermodynamics**. By **C. F. Hirschfeld**. 22 illus., 157 pp., 18mo, boards. (*New York, 1907.*) 2s. net.
- Experimental Science: Elementary, Practical and Experimental Physics**. By **G. M. Hopkins**. Twenty-third edition, 920 illus., 1,100 pp., 8vo. (*New York, 1902.*) £1 1s. net.
- Reform in Chemical and Physical Calculations**. By **C. J. T. Hanssen**. Demy 4to. (1897.) 6s. 6d. net.

- Introduction to the Study of Colour Phenomena.** By J. W. Lovibond. 10 coloured plates, 48 pp., 8vo. (1905.) 5s. net.
- The Energy Chart.** Practical application to reciprocating steam-engines. By Captain H. R. Sankey. 157 illus., 170 pp., 8vo. (1907.) 7s. 6d. net.

PRICE BOOKS

- The Mechanical Engineers' Price Book.** By G. Brooks. 200 pp., pocket size ($6\frac{1}{2}$ in. by $3\frac{3}{4}$ in. by $\frac{1}{2}$ in. thick), leather cloth, with rounded corners. 4s. net.
- Approximate Estimates.** By T. E. Coleman. Fourth edition, 481 pp., oblong 32mo, leather. (1914.) 5s. net.
- The Civil Engineers' Cost Book.** By Major T. E. Coleman. xii + 289 pp., pocket size ($6\frac{1}{2}$ in. by $3\frac{3}{4}$ in.), leather cloth. (1912.) 5s. net.
- Railway Stores Price Book.** By W. O. Kempthorne. 490 pp., demy 8vo. (1909.) 10s. 6d. net.
- Handbook of Cost Data for Contractors and Engineers.** By H. P. Gillette. 1,854 pp., crown 8vo, leather, gilt edges. (New York, 1911.) £1 1s. net.
- Spons' Architects' and Builders' Pocket Price-Book.** Edited by Clyde Young. Revised by Stanford M. Brooks. Forty-first ed., viii + 308 pp., green leather cloth. Published annually. (Size $6\frac{1}{2}$ in. by $3\frac{3}{4}$ in. by $\frac{1}{2}$ in. thick.) 2s. 6d. net.

RAILWAY ENGINEERING AND MANAGEMENT

- Practical Hints to Young Engineers Employed on Indian Railways.** By A. W. C. Addis. 14 illus., 154 pp., 12mo. (1910.) 3s. 6d. net.
- Up-to-date Air Brake Catechism.** By R. H. Blackall. Twenty-fifth edition, 5 coloured plates, 96 illus., 305 pp., crown 8vo. (New York, 1913.) 8s. 6d. net.
- Prevention of Railroad Accidents, or Safety in Railroading.** By Geo. Bradshaw. 64 illus., 173 pp., square crown 8vo. (New York, 1912.) 2s. 6d. net.
- Simple and Automatic Vacuum Brakes.** By C. Briggs, G.N.R. 11 plates, 8vo. (1892.) 4s.

- Notes on Permanent-way Material, Plate-laying, and Points and Crossings.** By W. H. Cole. Sixth edition, revised, 44 illus. in 39 plates, 203 pp., crown 8vo. (1912.) 7s. 6d. net.
- Statistical Tables of the Working of Railways** in various countries up to the year 1904. By J. D. Diacomidis. Second edition, 84 pp., small folio, sewed. (1906.) 16s. net.
- Locomotive Breakdowns, Emergencies and their Remedies.** By Geo. L. Fowler, M.E., and W. W. Wood. Fifth edition, 92 illus., 266 pp., 12mo. (New York, 1911.) 4s. 6d. net.
- Permanent-way Diagrams.** By F. H. Frere. Mounted on linen in cloth covers. (1908.) 3s. net.
- Formulæ for Railway Crossings and Switches.** By J. Glover. 9 illus., 28 pp., royal 32mo. (1896.) 2s. 6d.
- Setting out of Tube Railways.** By G. M. Halden. 9 plates, 46 illus., 68 pp., crown 4to. (1907.) 10s. 6d. net.
- Railway Engineering, Mechanical and Electrical.** By J. W. C. Haldane. New edition, 141 illus., xx + 583 pp., 8vo. (1908.) 15s.
- The Construction of the Modern Locomotive.** By G. Hughes. 300 illus., 261 pp., 8vo. (1894.) 9s.
- Practical Hints for Light Railways at Home and Abroad.** By F. R. Johnson. 6 plates, 31 pp., crown 8vo. (1896.) 2s. 6d.
- Handbook on Railway Stores Management.** By W. O. Kempthorne. 268 pp., demy 8vo. (1907.) 10s. 6d. net.
- Railway Stores Price Book.** By W. O. Kempthorne. 490 pp., demy 8vo. (1909.) 10s. 6d. net.
- Railroad Location Surveys and Estimates.** By F. Lavis. 68 illus., 270 pp., 8vo. (New York, 1906.) 12s. 6d. net.
- Pioneering.** By F. Shelford. 14 illus., 88 pp., crown 8vo. (1909.) 3s. net.
- Handbook on Railway Surveying** for Students and Junior Engineers. By B. Stewart. 55 illus., 98 pp., crown 8vo. (1909.) 2s. 6d. net.
- Modern British Locomotives.** By A. T. Taylor. 100 diagrams of principal dimensions, 118 pp., oblong 8vo. (1907.) 4s. 6d. net.
- Locomotive Slide Valve Setting.** By C. E. Tully. Illustrated, 18mo. 1s. net.

- The Railway Goods Station.** By F. W. West. 23 illus., xv + 192 pp., crown 8vo. (1912.) 4s. 6d. net.
- The Walschaert Locomotive Valve Gear.** By W. W. Wood. 4 plates and set of movable cardboard working models of the valves, 193 pp., crown 8vo. (New York, 1912.) 6s. 6d. net.
- The Westinghouse E.T. Air-Brake Instruction Pocket Book.** By W. W. Wood. 48 illus., including many coloured plates, 242 pp., crown 8vo. (New York, 1909.) 8s. 6d. net.

SANITATION, PUBLIC HEALTH AND MUNICIPAL ENGINEERING

- Engineering Work in Public Buildings.** By R. O. Allsop. 77 illus., ix + 158 pp., demy 4to. (1912.) 12s. 6d. net.
- Public Abattoirs, their Planning, Design and Equipment.** By R. S. Ayling. 33 plates, 100 pp., demy 4to. (1908.) 8s. 6d. net.
- Sewage Purification.** By E. Bailey-Denton. 8 plates, 44 pp., 8vo. (1896.) 5s.
- Water Supply and Sewerage of Country Mansions and Estates.** By E. Bailey-Denton. 76 pp., crown 8vo. (1901.) 2s. 6d. net.
- Sewerage and Sewage Purification.** By M. N. Baker. Second edition, 144 pp., 18mo, boards. (New York, 1905.) 2s. net.
- Bacteriology of Surface Waters in the Tropics.** By W. W. Clemesha. viii + 161 pp., 8vo. (Calcutta, 1912.) 7s. 6d. net.
- Housing and Town-Planning Conference, 1913.** Being a Report of a Conference held by the **Institution of Municipal and County Engineers** at Great Yarmouth. Edited by T. Cole. 42 folding plates, 227 pp., 8vo. 10s. 6d. net.
- Housing and Town Planning Conference, 1911.** Report of Conference held by the **Institution of Municipal and County Engineers** at West Bromwich. Edited by T. Cole, Secretary. 30 plates, 240 pp., 8vo. 10s. 6d. net.

- Sanitary House Drainage**, its Principles and Practice. By T. E. Coleman. 98 illus., 206 pp., crown 8vo. (1896.) 3s. 6d. net.
- Stable Sanitation and Construction.** By T. E. Coleman. 183 illus., 226 pp., crown 8vo. (1897.) 3s. net.
- Discharge of Pipes and Culverts.** By P. M. Crosthwaite. Large folding sheet in case. 2s. 6d. net.
- A Complete and Practical Treatise on Plumbing and Sanitation.** By G. B. Davis and F. Dye. 2 vols., 637 illus. and 21 folding plates, 830 pp., 4to, cloth. (1899.) £1 10s. net.
- Standard Practical Plumbing.** By P. J. Davies.
Vol. I. Fourth edition, 768 illus., 355 pp., royal 8vo. (1905.) 7s. 6d. net.
Vol. II. Second edition, 953 illus., 805 pp. (1905.) 10s. 6d. net.
Vol. III. 313 illus., 204 pp. (1905.) 5s. net.
- Conservancy, or Dry Sanitation versus Water Carriage.** By J. Donkin. 7 plates, 33 pp., 8vo, sewed. (1906.) 1s. net.
- Sewage Disposal Works.** By W. C. Easdale. 160 illus., 264 pp., 8vo. (1910.) 10s. 6d. net.
- House Drainage and Sanitary Plumbing.** By W. P. Gerhard. Tenth edition, 6 illus., 231 pp., 18mo, boards. (New York, 1902.) 2s. net.
- The Treatment of Septic Sewage.** By G. W. Rafter. 137 pp., 18mo, boards. (New York, 1904.) 2s. net.
- Reports and Investigations on Sewer Air and Sewer Ventilation.** By R. H. Reeves. 8vo, sewed. (1894.) 1s.
- Sewage Drainage Systems.** By Isaac Shone. 27 folding plates, 47 illus., 440 pp., 8vo. (1914.) 25s. net.
- Drainage and Drainage Ventilation Methods.** By Isaac Shone, C.E. 7 folding plates, 36 pp., 8vo, leather. (1913.) 6s. net.
- The Law and Practice of Paving Private Street Works.** By W. Spinks. Fourth edition, 256 pp., 8vo. (1904.) 12s. 6d. net.

STRUCTURAL DESIGN

(See Bridges and Roofs)

TELEGRAPH CODES

New Business Code. 320 pp., narrow 8vo. (Size $4\frac{3}{4}$ in. by $7\frac{3}{4}$ in. and $\frac{1}{2}$ in. thick, and weight 10 oz.) (*New York, 1909.*)
£1 is. net.

Miners' and Smelters' Code (formerly issued as the **Master Telegraph Code**). 448 pp., 8vo, limp leather, weight 14 oz. (*New York, 1899.*) £2 10s. net.

Billionaire Phrase Code, containing over two million sentences coded in single words. 56 pp., 8vo, leather. (*New York, 1908.*) 6s. 6d. net.

WARMING AND VENTILATION

Heat for Engineers. By **C. R. Darling.** Second edition, 110 illus., 430 pp., 8vo. (FINSBURY TECHNICAL MANUAL.) (*1912.*) 12s. 6d. net.

Hot Water Supply. By **F. Dye.** Fifth edition, new impression, 48 illus., viii + 86 pp., 8vo. (*1912.*) 3s. net.

A Practical Treatise upon Steam Heating. By **F. Dye.** 129 illus., 246 pp., 8vo. (*1901.*) 10s. net.

Practical Treatise on Warming Buildings by Hot Water. By **F. Dye.** 192 illus., 319 pp., 8vo. (*1905.*) 8s. 6d. net.

Charts for Low Pressure Steam Heating. By **J. H. Kinealy.** Small folio. (*New York.*) 4s. 6d.

Formulæ and Tables for Heating. By **J. H. Kinealy.** 18 illus., 53 pp., 8vo. (*New York, 1899.*) 3s. 6d.

Centrifugal Fans. By **J. H. Kinealy.** 33 illus., 206 pp., fcap. 8vo, leather. (*New York, 1905.*) 12s. 6d. net.

Mechanical Draft. By **J. H. Kinealy.** 27 original tables and 13 plates, 142 pp., crown 8vo. (*New York, 1906.*) 8s. 6d. net.

Theory and Practice of Centrifugal Ventilating Machines. By **D. Murgue.** 7 illus., 81 pp., 8vo. (*1883.*) 5s.

Mechanics of Ventilation. By **G. W. Rafter.** Second edition, 143 pp., 18mo, boards. (*New York, 1896.*) 2s. net.

- Principles of Heating.** By W. G. Snow. New edition, 59 illus., xii + 224 pp., 8vo. (*New York, 1912.*) 9s. net.
- Furnace Heating.** By W. G. Snow. Fourth edition, 52 illus., 216 pp., 8vo. (*New York, 1909.*) 6s. 6d. net.
- Ventilation of Buildings.** By W. G. Snow and T. Nolan. 83 pp., 18mo, boards. (*New York, 1906.*) 2s. net.
- Heating Engineers' Quantities.** By W. L. White and G. M. White. 4 plates, 33 pp., folio. (*1910.*) 10s. 6d. net.

WATER SUPPLY

(See also Hydraulics)

- Potable Water and Methods of Testing Impurities.** By M. N. Baker. 97 pp., 18mo, boards. (*New York, 1905.*) 2s. net.
- Manual of Hydrology.** By N. Beardmore. New impression, 18 plates, 384 pp., 8vo. (*1906.*) 10s. 6d. net.
- Boiler Waters, Scale, Corrosion and Fouling.** By W. W. Christie. 77 illus., 235 pp., 8vo. (*New York, 1907.*) 12s. 6d. net.
- Bacteriology of Surface Waters in the Tropics.** By W. W. Clemesha. 12 tables, viii + 161 pp., 8vo. (*Calcutta, 1912.*) 7s. 6d. net.
- Water Softening and Purification.** By H. Collet. Second edition, 6 illus., 170 pp., crown 8vo. (*1908.*) 5s. net.
- Treatise on Water Supply, Drainage and Sanitary Appliances of Residences.** By F. Colyer. 100 pp., crown 8vo. (*1899.*) 1s. 6d. net.
- Purification of Public Water Supplies.** By J. W. Hill. 314 pp., 8vo. (*New York, 1898.*) 10s. 6d.
- Well Boring for Water, Brine and Oil.** By C. Isler. Second edition, 105 illus., 296 pp., 8vo. (*1911.*) 10s. 6d. net.
- Method of Measuring Liquids Flowing through Pipes by means of Meters of Small Calibre.** By Prof. G. Lange. 1 plate, 16 pp., 8vo, sewed. (*1907.*) 6d. net.
- On Artificial Underground Water.** By G. Richert. 16 illus., 33 pp., 8vo, sewed. (*1900.*) 1s. 6d. net.
- Notes on Water Supply in new Countries.** By F. W. Stone. 18 plates, 42 pp., crown 8vo. (*1888.*) 5s.

The Principles of Waterworks Engineering. By **J. H. T. Tudsbery** and **A. W. Brightmore.** Third edition, 13 folding plates, 130 illus., 447 pp., demy 8vo. (1905.) £1 1s. net.

WORKSHOP PRACTICE

For Art Workers and Mechanics

Alphabet of Screw Cutting. By **L. Arnaudon,** Fifth edition, 92 pp., cr. 8vo., sewed. (1913.) 4s. net.

A Handbook for Apprenticed Machinists. By **O. J. Beale.** Second edition, 89 illus., 141 pp., 16mo. (*New York, 1901.*) 2s. 6d. net.

Practice of Hand Turning. By **F. Campin.** Third edition, 99 illus., 307 pp., crown 8vo. (1883.) 3s. 6d.

Artistic Leather Work. By **E. Ellin Carter.** 6 plates and 21 illus., xii + 51 pp., crown 8vo. (1912.) 2s. 6d. net.

Calculation of Change Wheels for Screw Cutting on Lathes. By **D. de Vries.** 46 illus., 83 pp., 8vo. (1908.) 3s. net.

Milling Machines and Milling Practice. By **D. de Vries.** 536 illus., 464 pp., medium 8vo. (1910.) 14s. net.

French-Polishers' Manual. By a **French-Polisher.** New impression, 31 pp., royal 32mo, sewed. (1912.) 6d. net.

Art of Copper-Smithing. By **J. Fuller.** Fourth edition, 483 illus., 319 pp., royal 8vo. (*New York, 1911.*) 12s. 6d. net.

Saw Filing and Management of Saws. By **R. Grimshaw.** New edition, 81 illus., 16mo. (*New York, 1906.*) 4s. 6d. net.

Cycle Building and Repairing. By **P. Henry.** 55 illus., 96 pp., cr. 8vo. (S. & C. SERIES, No. 43.) 1s. 6d. net.

Paint and Colour Mixing. By **A. S. Jennings.** Fourth edition, 14 coloured plates, 190 pp., 8vo. (1910.) 5s. net.

The Mechanician : a Treatise on the Construction and Manipulation of Tools. By **C. Knight.** Fifth edition, 96 plates, 397 pp., 4to. (1897.) 18s.

Turner's and Fitter's Pocket Book. By **J. La Nicca.** 18mo, sewed. 6d.

- Tables for Engineers and Mechanics**, giving the values of the different trains of wheels required to produce Screws of any pitch. By **Lord Lindsay**. Second edition, royal 8vo, oblong. 2s.
- Screw-cutting Tables**. By **W. A. Martin**. Seventh edition. New imp., oblong 8vo. 1s. net.
- Metal Plate Work**, its Patterns and their Geometry, for the use of Tin, Iron and Zinc Plate Workers. By **G. T. Millis**. Fourth Ed., New imp., 280 illus., xvi + 456 pp., cr. 8vo. (1912.) 9s.
- The Practical Handbook of Smithing and Forging**. Engineers' and General Smiths' Work. By **T. Moore**. New impression, 401 illus., 248 pp., crown 8vo. (1912.) 5s. net.
- Modern Machine Shop Construction**, equipment and management. By **O. E. Perrigo**. 208 illus., 343 pp., crown 4to. (New York, 1906.) £1 1s. net.
- Turner's Handbook on Screw-cutting, Coning, etc.** By **W. Price**. New impression, 56 pp., fcap. 8vo. (1912.) 6d. net.
- Introduction to Eccentric Spiral Turning**. By **H. C. Robinson**. 12 plates, 23 illus., 48 pp., 8vo. (1906.) 4s. 6d. net.
- Manual of Instruction in Hard Soldering**. By **H. Rowell**. Sixth edition, 7 illus., 66 pp., crown 8vo. (New York, 1910.) 3s. net.
- Forging, Stamping, and General Smithing**. By **B. Saunders**. 728 illus., ix + 428 pp., demy 8vo. (1912.) £1 1s. net.
- Pocket Book on Boilermaking, Shipbuilding, and the Steel and Iron Trades in General**. By **M. J. Sexton**. Sixth edition, new impression, 85 illus., 319 pp., royal 32mo, roan, gilt edges. (1912.) 5s. net.
- Power and its Transmission**. A Practical Handbook for the Factory and Works Manager. By **T. A. Smith**. 76 pp., fcap. 8vo. (1910.) 2s. net.
- Spons' Mechanics' Own Book**: A Manual for Handicraftsmen and Amateurs. Sixth edition, New impression, 1,430 illus., 720 pp., demy 8vo. (1912.) 6s.
Ditto ditto half French morocco, 7s. 6d.

Spens' Workshop Receipts for Manufacturers, Mechanics and Scientific Amateurs. New and thoroughly revised edition, crown 8vo. (1909.) 3s. each net.

Vol. I. ACETYLENE LIGHTING to DRYING. 223 illus., 532 pp.

Vol. II. DYEING to JAPANING. 259 illus., 540 pp.

Vol. III. JOINTING PIPES to PUMPS. 257 illus., 528 pp.

Vol. IV. RAINWATER SEPARATORS to WIRE ROPES. 321 illus., 540 pp.

Gauges at a Glance. By **T. Taylor.** Second edition, post 8vo, oblong, with tape converter. (1900.) 5s. net.

Simple Soldering, both Hard and Soft. By **E. Thatcher.** 52 illus., 76 pp., crown 8vo. (S. & C. Series, No. 18.) (New York, 1910.) 1s. 6d. net.

The Modern Machinist. By **J. T. Usher.** Fifth edition, 257 illus., 322 pp., 8vo. (New York, 1904.) 10s. 6d. net.

Practical Wood Carving. By **C. J. Woodsend.** 108 illus., 86 pp., 8vo. (New York, 1897.) 4s. 6d. net.

American Tool Making and Interchangeable Manufacturing. By **J. W. Woodworth.** Second Ed. 600 illus., 535 pp., 8vo (New York, 1911.) 18s. net.

USEFUL TABLES

See also CURVE TABLES, EARTHWORK, FOREIGN EXCHANGE, INTEREST TABLES, LOGARITHMS, AND METRIC TABLES.

Weights and Measurements of Sheet Lead. By **J. Alexander.** 32mo, roan. 1s. 6d. net.

Barlow's Tables of Squares, Cubes, Square Roots, Cube Roots and Reciprocals, of all Integer Numbers from 1 to 10,000. 200 pp., crown 8vo, leather cloth. 4s. net.

Tables of Squares. Of every foot, inch and $\frac{1}{16}$ of an inch from $\frac{1}{16}$ of an inch to 50 feet. By **E. E. Buchanan.** Eleventh edition, 102 pp., 16mo. 4s. 6d. net.

Land Area Tables. By **W. Codd.** For use with Amsler's Planimeter. On sheet in envelope with explanatory pamphlet, 1s. 6d. net. Or separately: tables on sheet 1s. net. Pamphlet, 6d. net.

- Tables of some of the Principal Speeds** occurring in Mechanical Engineering, expressed in Mètres per second. By **K. Keerayeff**. 18mo, sewed. 6*d.* net.
- Calculating Scale.** A Substitute for the Slide Rule. By **W. Knowles**. Crown 8vo, leather. 1*s.* net.
- Planimeter Areas.** Multipliers for various scales. By **H. B. Molesworth**. Folding sheet in cloth case. 1*s.* net.
- Tables of Seamless Copper Tubes.** By **I. O'Toole**. 69 pp., oblong fcap. 8vo. 3*s.* 6*d.* net.
- Steel Bar and Plate Tables.** Giving Weight per Lineal Foot of all sizes of L and T Bars, Flat Bars, Plates, Square, and Round Bars. By **E. Read**. On large folding card. 1*s.* net.
- Rownson's Iron Merchants' Tables and Memoranda.** Weight and Measures. 86 pp., 32mo, leather. 3*s.* 6*d.*
- Spons' Tables and Memoranda for Engineers.** By **J. T. Hurst**, C.E. Twelfth edition, 278 pp., 64mo, roan, gilt edges. (1907.) 1*s.* net.
Ditto ditto in celluloid case, 1*s.* 6*d.* net.
- Optical Tables and Data**, for the use of Opticians. By Prof. **S. P. Thompson**. Second edition, 130 pp., oblong 8vo. (1907.) 6*s.* net.
- Traverse Table**, showing Latitudes and Departure for each Quarter degree of the Quadrant, and for distances from 1 to 100; etc. 18mo, boards. 2*s.* net.
- The Wide Range Dividend and Interest Calculator**, showing at a glance the percentage on any sum from £1 to £10,000, at any Interest from 1% to 12½%, proceeding by ¼%; also Table of Income Tax deductions on any sum from £1 to £10,000, at 9*d.*, 1*s.*, and 1*s.* 2*d.* in the £. By **Alfred Stevens**. 100 pp., super royal. 8vo. 5*s.* net. Quarter Morocco, cloth sides. 7*s.* 6*d.* net.
- The Wide Range Income Tax Calculator**, showing at a glance the tax on any sum from One Shilling to Ten Thousand Pounds at the Rates of 9*d.*, 1*s.*, and 1*s.* 2*d.* in the £. By **Alfred Stevens**. 8 pp., printed on stiff card, royal 8vo. 1*s.* net.
- Fifty-four Hours' Wages Calculator.** By **H. N. Whitelaw**. Second edition, 79 pp., 8vo. 2*s.* 6*d.* net.

Wheel Gearing. Tables of Pitch Line Diameters, etc. By **A. Wildgoose** and **A. J. Orr.** 175 pp., fcap. 32mo. 2s. net.

MISCELLANEOUS

The Atmosphere: Its Characteristics and Dynamics. By **F. J. B. Cordeiro.** 35 illus., 129 pp., crown 4to. (*New York, 1910.*) 10s. 6d. net.

Popular Engineering. By **F. Dye.** 704 illus., 477 pp., crown 4to. (*1895.*) 5s. net.

The Phonograph, and how to construct it. By **W. Gillett.** 6 folding plates, 87 pp., crown 8vo. (*1892.*) 5s.

Engineering Law. By **A. Haring.** Demy 8vo, cloth. (*New York.*)

Vol. I. THE LAW OF CONTRACT. 518 pp. (*1911.*) 17s. net.

The Gyroscope, an Experimental Study. By **V. E. Johnson.** 34 illus., 40 pp., crown 8vo. (S. & S. SERIES, No. 22.) (*1911.*) 1s. 6d. net.

Particulars of Dry Docks, Wet Docks, Wharves, etc., on the River Thames. By **C. H. Jordan.** Second edition, 7 coloured charts, 103 pp., oblong 8vo. (*1904.*) 2s. 6d. net.

New Theories in Astronomy. By **W. Stirling.** 335 pp., demy 8vo. (*1906.*) 8s. 6d. net.

The American Hardware Store. A Manual of approved methods of arranging and displaying hardware. By **R. R. Williams.** 500 illus., 448 pp., royal 8vo. (*New York, 1896.*) 7s. 6d. net.

Inventions, How to Protect, Sell and Buy Them. By **F. Wright.** 118 pp., crown 8vo. (S. & C. SERIES, No. 10.) (*New York, 1908.*) 1s. 6d. net.

The Journal of the Iron and Steel Institute.

Edited by G. C. LLOYD, *Secretary.*

Published Half-yearly, 8vo. 16s. net.

Carnegie Scholarship Memoirs.

Published Annually, 8vo. 10s. net.

The Journal of the Institution of Electrical Engineers.

Edited by P. F. ROWELL, *Secretary.*

Issued in quarto parts. The number of parts will be from 12 to 16 annually. Annual Subscription, 46s., payable in advance. Single numbers, 3s. 9d. post free.

The Proceedings of the Institution of Municipal and County Engineers.

Edited by THOMAS COLE, Assoc.M.Inst.C.E. *Secretary.*

Issued in monthly parts (fortnightly during April, May, June and July). Price 1s. 9d., post free, each part.

Transactions of the Institution of Gas Engineers.

Edited by WALTER T. DUNN, *Secretary.*

Published Annually, 8vo. 10s. 6d. net

Proceedings of the International Association for Testing Materials.

(English Edition.)

Proceedings of 5th Congress, 18s. net. Proceedings of 6th Congress, 30s. net.

Transactions of the American Institute of Chemical Engineers.

Published Annually, 8vo. 30s. net.

THIS BOOK IS DUE ON THE LAST DATE
STAMPED BELOW

AN INITIAL FINE OF 25 CENTS
WILL BE ASSESSED FOR FAILURE TO RETURN
THIS BOOK ON THE DATE DUE. THE PENALTY
WILL INCREASE TO 50 CENTS ON THE FOURTH
DAY AND TO \$1.00 ON THE SEVENTH DAY
OVERDUE.

OCT 18 1932

7 Mar '58 ES

DEC 9 1932

REC'D LD
FEB 21 1958

DEC 27 1932

6 Jan '64 BX

DEC 17 1932

REC'D LD
JAN 19 '64 - 5 PM

FEB 18 1939

MAY 18 1939

JAN 2 1943

28 May '52 KU

14 May 52 L

LD 21-50m-8, '32

360736

QC15
-04

R. Williams

UNIVERSITY OF CALIFORNIA LIBRARY

